

**AGENDA
HIDALGO COUNTY
COMMISSIONERS COURT
MEETING
January 26, 2016
9:30 A.M.**

NOTICE is hereby given in accordance with Chapter 551, Texas Government Code, that a REGULAR MEETING of the Commissioners Court will be held in the Commissioners Courtroom of the Administration Building, 100 E. Cano, 1st floor, Edinburg, Hidalgo County, Texas. Discussion and possible action relating to the following business will be transacted:

1. **Roll Call**
2. **Pledge of Allegiance**
3. **Prayer**
4. **Approval of Consent Agenda**
5. **Open Forum**
6. **Constables:**
 - A. AI-53066 Constable Pct. #1:
Requesting authorization for the County Judge to execute the 2016 Equitable Sharing Agreement and Certification Report.
 - B. AI-52909 Constable Pct. #2:
Requesting authorization for the County Judge to execute the 2016 Equitable Sharing Agreement and Certification Report
 - C. AI-53044 Constable Pct. #4:
Presentation and discussion of 2015 Racial Profiling Report as presented by Hidalgo County Constable Precinct 4 Department in accordance with Article 2.134 of the Texas Code of Criminal Procedures.
7. **Executive Office:**
 - A. AI-53032 Requesting approval to donate twenty-one (21) 1921 Old Jail and eighteen (18) 1985 Jail keys to the Museum of South Texas History.
8. **Health & Human Services Department:**

A. **Health Care Funding District:**

- 1. Discussion and/or action, including but not limited to Health Care Funding District and/or Expenditures

B. **Indigent Health Care Program:**

- 1. Discussion and/or action, including but not limited to Indigent Health Care Program and 1115 Waiver and/or Expenditures

9. **IT Department:**

A. AI-53085 WIC PROGRAM:

Authorization and approval to purchase new wireless device with service through the County's membership/participation with CONTRACT: DIR-SDD-1779 for VERIZON WIRELESS for the following:

Qty:	Description:	Employee Name:	Service Plan:	Equipment:
1	Cell Phone	Office Use	America's Choice II 400 Share UNL. IN&N&W @ \$29.99 + \$5.00 taxes/fees = \$34.99 per month	Kyocera Dura XV+ @ \$0.

B. AI-52929 FIRE MARSHAL/PLANNING DEPT.:

Authorization and approval to upgrade wireless equipment, downgrade service plan and change assigned name on devices through the County's membership/participation with CONTRACT: DIR-SDD-1779 for VERIZON WIRELESS for the following:

Qty:	Description:	Employee Name/ID:	Service Plan:	Equipment:	MDN:
6	Downgrade Service Plan and Upgrade Equipment	See Attachment	America's Choice II 400 Share Email & Data+N&W IN UNL @ \$49.99 + \$5.00 taxes/fees = \$54.99/ea per month	iPhone 5s 16GB	See Attachment
8	Upgrade Equipment	See Attachment	4G Mobile Broadband UNL @ \$37.99/ea per month	Verizon AC791L	See Attachment

Department:	Description:	Employee Name/ID:	Transfer To:	Device:	MDN:
Fire Marshal	Name Change	Kyle Pulley/203742	Office Use	Cell Phone	956-929-6497
Fire Marshal	Name Change	Juan Martinez/138126	Office Use	Data Card	956-342-3707
Fire Marshal	Name Change	Kyle Pulley/203742	Office Use	Data Card	956-342-3675
Planning	Name Change	Eli Villegas/185817	Office Use	Cell Phone	956-358-8579

10. **Elections Administration:**

- A. Discussion and/or action, including but not limited to Elections updates

11. **Budget & Management:**

- A. AI-53068 Human Services - 1115 Waiver DSRIP (1100):
Approval to designate the amount of \$764,521.67 in the year 2015 for expenditures related to the 1115 Waiver Program.

Purchasing Department:

Notes:

12. **A. FOR ANY CONTRACT(S) AWARDED AND APPROVED UNDER THIS AGENDA, EXECUTED COPIES OF THE CONTRACT(S) WILL BE AVAILABLE ON THE COUNTY INTRA-NET WEBSITE AND WILL BE FOWARDED VIA E-MAIL, FAX OR HAND DELIVERED TO HIDALGO COUNTY AUDITOR'S OFFICE.**
- B. ANY AND ALL REQUESTS FOR PAYMENT(S) APPROVED WILL BE SUBJECT TO COUNTY AUDITORS PROCESSING PROCEDURES INCLUDING AUTHORITY FOR COUNTY TREASURER TO ISSUE PAYMENT(S)/CHECK(S).**

- A. AI-52871 Acceptance of two (2) rebate checks from:
1. The Local Government Purchasing Cooperative in the amount of \$ 44,963.47
 2. Staples in the amount of \$ 25,442.92 for the year 2014-2015 fiscal year.

B. **Hidalgo County**

1. AI-52930 Presentation of bids received for the purposes of award and approval of contract document to vendor submitting the lowest and best bid meeting all specifications and/or requirements as attached hereto for: Hidalgo County - "Sign Language Interpreting Services for Courtroom and Non-Courtroom" and subject to HB1295 and all other HC compliance items.

C. **Pct. 1**

1. AI-52678 Presentation of Sole bid received as detailed in tabulation sheet contained herein meeting all specifications and/or requirements for the purpose of award and approval of contract and subject to compliance with HB23 and HB1295 (if and when applicable)- for Request for Bid titled: Hidalgo County Pct1- "Lease of Parcel for Citizen Collection Site(s) 1 in Mercedes and 1 in Donna" through project No.: 2016-013-12-09-SGS.

D. **Pct. 3**

1. AI-52689 Approval of Governmental Equipment Lease-Purchase Agreement No. 2758156 between Holt CAT Truck Center thru the Buyboard Contract# 431-13, Caterpillar financial Services Corporation and Hidalgo County for the lease-purchase of two (2) 2016 or newer CT660 Trucks for Pct 3 with authority for the County Judge to sign all related documents for financing purposes and subject to HB1295.
13. AI-53079 Discussion and action employing counsel for review of current and past liability lines of coverage for Hidalgo County

Closed Session:

14. Commissioners' Court may go into Closed Session pursuant to Chapter 551, Texas Government Code, Sections 551.071 & 551.072 to discuss the following:
 - A. Real Estate Acquisition
 - B. Pending and/or potential litigation
 - C. AI-53072 Civil Action No. 7:14-cv-471; Eugenio Espinoza Martinez v. Hidalgo County, Texas, et al
 - D. AI-53074 C-0262-16-G; Teresa Barrera et al v. Hidalgo County, Texas and Hidalgo County Drainage District No. 1
 - E. AI-53055 Claim of Verizon
 - F. AI-53060 Claim of Cesar Rojas & Elena Cortez

15. A. Requesting exemption from competitive bidding requirements under the Texas Local Government Code, Section 262.024(A) (4) "a Professional Service" for the "provision of legal services/representation in connection with litigation."
- B. Requesting engagement with the firm of _____ for the "Provision of Legal Services/Representation in connection with Litigation" and authority to submit letter of engagement
16. **Open Session:**
- A. Real Estate Acquisition and appropriation for same
- B. Pending and/or potential litigation
- C. AI-53073 Civil Action No. 7:14-cv-471; Eugenio Espinoza Martinez v. Hidalgo County, Texas, et al
- D. AI-53075 C-0262-16-G; Teresa Barrera et al v. Hidalgo County, Texas and Hidalgo County Drainage District No. 1
- E. AI-53056 Claim of Verizon
- F. AI-53061 Claim of Cesar Rojas & Elena Cortez
- Closed Session:**
17. Commissioners' Court may reconvene into Closed Session for the discussion regarding the agenda items listed
- Open Session:**
18. Commissioners' Court may reconvene into Open Session for the discussion regarding the agenda items listed
19. **Adjourn**

AI-53066

Constables 6. A.

CC - REGULAR

Meeting Date: 01/26/2016

Submitted Constable Celestino Avila, Jr., CONSTABLE PCT. #1

For:

Submitted By: Joe Espinoza, CONSTABLE PCT. #1

Department: CONSTABLE PCT. #1

Information

CAPTION

Constable Pct. #1:

Requesting authorization for the County Judge to execute the 2016 Equitable Sharing Agreement and Certification Report.

BACKGROUND

Fiscal Impact

Attachments

No file(s) attached.

Form Review

Inbox	Reviewed By	Date
Budget & Management	Veronica Ortiz	01/22/2016 01:31 PM
Purchasing Department	Monica Badillo	01/22/2016 04:11 PM
Form Started By: Joe Espinoza		Started On: 01/22/2016 01:09 PM
Final Approval Date: 01/22/2016		

AI-52909

Constables 6. B.

CC - REGULAR

Meeting Date: 01/26/2016

Submitted By: Roxanne De La Cruz,
CONSTABLE PCT. #2

Department: CONSTABLE PCT. #2

Information

CAPTION

Constable Pct. #2:

Requesting authorization for the County Judge to execute the 2016 Equitable Sharing Agreement and Certification Report

BACKGROUND

Fiscal Impact

Attachments

Equitable Sharing Agreement and Certification

Form Review

Inbox	Reviewed By	Date
Budget & Management	Veronica Ortiz	01/12/2016 09:25 AM
Purchasing Department	Monica Badillo	01/22/2016 04:11 PM
Form Started By: Roxanne De La Cruz		Started On: 01/11/2016 03:30 PM
Final Approval Date: 01/22/2016		



Equitable Sharing Agreement and Certification



OMB Number 1123-0011
Expires January 31, 2018

- Police Department
 Sheriff's Office
 Task Force (Complete Table A)
 Prosecutor's Office
 National Guard Counterdrug Unit
 Other

* Please fill each required field. Hover mouse over any fillable field for pop-up instructions. *

Agency Name: Hidalgo County Constable Pct. 2

NCIC/ORI/Tracking Number:

T	X	1	0	8	1	9	0	0
---	---	---	---	---	---	---	---	---

Mailing Address: 300 West Hall Acres Suite E

City: Pharr

State: TX

Zip: 78577

Finance Contact: First: Martin

Last: Cantu

Phone: 956-784-3510

Email: martin.cantu@co.hidalgo.tx.us

Preparer: First: Martin

Last: Cantu

Same as Finance Contact

Phone: 956-784-3510

Email: martin.cantu@co.hidalgo.tx.us

Last FY End Date: 12/31/2015

Agency Current FY Budget: _____

\$1,042,319.00

- New Participant:** Read Equitable Sharing Agreement and sign Affidavit
 Existing Participant: Complete Annual Certification Report, read Equitable Sharing Agreement, and electronically sign Affidavit
 Amended Form: Revise Annual Certification Report, read Equitable Sharing Agreement, and electronically sign Affidavit

Annual Certification Report

Summary of Equitable Sharing Activity		Justice Funds ¹	Treasury Funds ²
1	Beginning Equitable Sharing Funds Balance (Must match Ending Balance from prior FY)	\$0.00	\$0.00
2	Equitable Sharing Funds Received		
3	Equitable Sharing Funds Received from Other Law Enforcement Agencies and Task Forces (Complete Table B)		
4	Other Income		
5	Interest Income <input checked="" type="radio"/> Non-Interest Bearing <input type="radio"/> Interest Bearing		
6	Total Equitable Sharing Funds (total of lines 1 - 5)	\$0.00	\$0.00
7	Equitable Sharing Funds Spent (total of lines a - n below)	\$0.00	\$0.00
8	Ending Equitable Sharing Funds Balance (difference between line 7 and line 6)	\$0.00	\$0.00

¹ Department of Justice Asset Forfeiture Program participants are: FBI, DEA, ATF, USPIS, USDA, DCIS, DSS, and FDA.

² Department of the Treasury Asset Forfeiture Program participants are: IRS, ICE, CBP, AND USSS.

Summary of Shared Funds Spent		Justice Funds	Treasury Funds
a	Law enforcement operations and investigations	\$0.00	\$0.00
b	Training and education		
c	Law enforcement, public safety, and detention facilities		
d	Law enforcement equipment		
e	Joint law enforcement/public safety operations		
f	Contracting for services		
g	Law enforcement travel and per diem		
h	Law enforcement awards and memorials		
i	Drug, gang, and other education or awareness programs		
j	Matching grants (Complete Table C)		
k	Transfers to other participating law enforcement agencies (Complete Table D)		
l	Support of community-based programs (Complete Table E)		
m	Non-categorized expenditures (Complete Table F)		
n	Salaries (Complete Table G)		
Total:		\$0.00	\$0.00

Please fill out the following tables, if applicable.

Table A: Members of Task Force

Agency Name	NCIC/ORI/Tracking Number

Table B: Equitable Sharing Funds Received from other Agencies

Transferring Agency Name, City, and State	Justice Funds	Treasury Funds
Agency Name: <input type="text"/>		
NCIC/ORI/Tracking Number: <input type="text"/>		

Table C: Matching Grants

Matching Grant Name	Justice Funds	Treasury Funds
<input type="text"/>		

Table D: Transfers to Other Participating Law Enforcement Agencies

Receiving Agency Name, City, and State	Justice Funds	Treasury Funds
Agency Name: <input type="text"/>	<input type="text"/>	<input type="text"/>
NCIC/ORI/Tracking Number: <input type="text"/>		

Table E: Support of Community-based Programs

Recipient	Justice Funds	Treasury Funds
<input type="text"/>	<input type="text"/>	<input type="text"/>

Table F: Expenditures not Categorized in (a) - (n) Above

Description	Justice Funds	Treasury Funds
<input type="text"/>	<input type="text"/>	<input type="text"/>

Table G: Salaries

Salary Type	Justice Funds	Treasury Funds
<input type="radio"/> Overtime <input type="radio"/> Match for Federal Salary Grant <input type="radio"/> DARE/SRO Officer <input type="radio"/> Federal Task Force Replacement Officer	<input type="text"/>	<input type="text"/>

Table H: Civil Rights Cases

Name of Case	Type of Discrimination Alleged			
	<input type="text"/>	<input type="checkbox"/> Race	<input type="checkbox"/> Color	<input type="checkbox"/> National Origin
	<input type="checkbox"/> Disability	<input type="checkbox"/> Age	<input type="checkbox"/> Other	<input type="text"/>

Paperwork Reduction Act Notice

Under the Paperwork Reduction Act, a person is not required to respond to a collection of information unless it displays a valid OMB control number. We try to create accurate and easily understood forms that impose the least possible burden on you to complete. The estimated average time to complete this form is 30 minutes. If you have comments regarding the accuracy of this estimate, or suggestions for making this form simpler, please write to the Asset Forfeiture and Money Laundering Section: 1400 New York Avenue, N.W., Washington, DC 20005.

Equitable Sharing Agreement

This Federal Equitable Sharing Agreement, entered into among (1) the Federal Government, (2) the above-stated law enforcement agency ("Agency"), and (3) the governing body, sets forth the requirements for participation in the federal Equitable Sharing Program and the restrictions upon the use of federally forfeited cash, property, proceeds, and any interest earned thereon, which are equitably shared with participating law enforcement agencies.

By submission of this form, the Agency agrees that it will be bound by the statutes and guidelines that regulate shared assets and the following requirements for participation in the Department of Justice and Department of the Treasury Equitable Sharing Programs. Receipt of the signed Equitable Sharing Agreement and Certification (this "Document") is a prerequisite to receiving any equitably shared cash, property, or proceeds.

1. Submission. This Document must be submitted to aca.submit@usdoj.gov within 60 days of the end of the Agency's fiscal year. This Document must be submitted and signed electronically. This will constitute submission to the Department of Justice and the Department of the Treasury.

2. Signatories. This agreement must be electronically signed by the head of the Agency and the head of the governing body. Examples of Agency heads include police chief, sheriff, director, commissioner, superintendent, administrator, chairperson, secretary, city attorney, county attorney, district attorney, prosecuting attorney, state attorney, commonwealth attorney, and attorney general. The governing body's head is the head of the agency that appropriates funding to the Agency. Examples of governing body heads include city manager, mayor, city council chairperson, county executive, county council chairperson, director, secretary, administrator, commissioner, and governor. The governing body head cannot be from the law enforcement agency and must be from a separate entity.

3. Uses. Any shared asset shall be used for law enforcement purposes in accordance with the statutes and guidelines that govern the Department of Justice and the Department of the Treasury Equitable Sharing Programs as set forth in the current edition of the *Guide to Equitable Sharing for State and Local Law Enforcement Agencies (Guide)*.

4. Transfers. Before the Agency transfers funds to other state or local law enforcement agencies, it must first verify with the Department of Justice that the receiving agency is a current and compliant Equitable Sharing Program participant. Transfers of tangible property are not permitted.

5. Internal Controls. The Agency agrees to account separately for federal equitable sharing funds received from the Department of Justice and the Department of the Treasury. Funds from state and local forfeitures, joint law enforcement operations funds, and other sources must not be commingled with federal equitable sharing funds.

The Agency agrees that such accounting will be subject to the standard accounting requirements and practices employed by the Agency's jurisdiction as supplemented by requirements set forth in the current edition of the *Guide*, including the requirement to maintain relevant documents and records for five years.

The misuse or misapplication of shared resources or supplantation of existing resources with shared assets is prohibited. The Agency must follow its jurisdiction's procurement policies when expending shared funds. Failure to comply with any provision of this agreement shall subject the recipient agency to the sanctions stipulated in the current edition of the *Guide*.

6. Audit Report. Audits will be conducted as provided by the Single Audit Act Amendments of 1996 and OMB Circular A-133. The Department of Justice and the Department of the Treasury reserve the right to conduct periodic random audits or reviews.

7. Freedom of Information Act. Information provided in this Document is subject to the FOIA requirements of the Department of Justice and the Department of the Treasury.

AI-53044

Constables 6. C.

CC - REGULAR

Meeting Date: 01/26/2016

Submitted Horaldo Sanchez, CONSTABLE PCT. #4

For:

Submitted By: Nayla Munoz, CONSTABLE PCT. #4

Department: CONSTABLE PCT. #4

Information

CAPTION

Constable Pct. #4:

Presentation and discussion of 2015 Racial Profiling Report as presented by Hidalgo County Constable Precinct 4 Department in accordance with Article 2.134 of the Texas Code of Criminal Procedures.

BACKGROUND

Fiscal Impact

Attachments

Tier 2 Report

Report

Code

Form Review

Inbox	Reviewed By	Date
Budget & Management	Veronica Ortiz	01/21/2016 10:16 AM
Purchasing Department	Monica Badillo	01/22/2016 04:11 PM
Form Started By: Nayla Munoz		Started On: 01/20/2016 01:33 PM
Final Approval Date: 01/22/2016		

TIER 2 - FULL RACIAL PROFILING REPORT

Agency Name: HIDALGO COUNTY CONSTABLE PRECINCT 4
Reporting Date: 1/26/2016
TCOLE Agency Number: 215104
Chief Administrator: ATANACIO "JR" GAITAN
Agency Contact Information:
Phone: 9563838560
Email: atanaico.gaitan@co.hidalgo.tx.us
Mailing Address:
2814 S. Business Highway 281
Edinburg, Texas 78539

This Agency filed a full report because: Our agency has no motor vehicle audio equipment.

Certification to This Report 2.132 (Tier 2) – Full Report

Article 2.132(b) CCP Law Enforcement Policy on Racial Profiling
HIDALGO COUNTY CONSTABLE PCT. 4 has adopted a detailed written policy on racial profiling. Our policy:

- (1) clearly defines acts constituting racial profiling;
- (2) strictly prohibit peace officers employed by the HIDALGO COUNTY CONSTABLE PCT. 4 from engaging in racial profiling;
- (3) implements a process by which an individual may file a complaint with the HIDALGO COUNTY CONSTABLE PCT. 4 if the individual believes that a peace officer employed by the HIDALGO COUNTY CONSTABLE PCT. 4 has engaged in racial profiling with respect to the individual;
- (4) provides public education relating to the agency's complaint process;
- (5) requires appropriate corrective action to be taken against a peace officer employed by the HIDALGO COUNTY CONSTABLE PCT. 4 who, after an investigation, is shown to have engaged in racial profiling in violation of the HIDALGO COUNTY CONSTABLE PCT. 4's policy adopted under this article;
- (6) require collection of information relating to motor vehicle stops in which a citation is issued and to arrests made as a result of those stops, including information relating to:
 - (A) the race or ethnicity of the individual detained;
 - (B) whether a search was conducted and, if so, whether the individual detained consented to the search; and

(C) whether the peace officer knew the race or ethnicity of the individual detained before
Page 1 of 5 pages submitted electronically to the Texas Commission on Law
Enforcement

(D) whether the peace officer knew the race or ethnicity of the individual detained before
detaining that individual; and

(7) require the chief administrator of the agency, regardless of whether the administrator is
elected, employed, or appointed, to submit an annual report of the information collected under
subdivision (6) to:

(A) the Commission on Law Enforcement; and

(B) the governing body of each county or municipality served by the agency, if the
agency is an agency of a county, municipality, or other political subdivision of the state.

I certify these policies are in effect.

Executed by: *ATANACIO "J.R." GAITAN*
Chief Administrator
HIDALGO COUNTY CONSTABLE PCT. 4

Date: 1/26/2016

HIDALGO CONSTABLE PCT. 4
Racial Profile Report
(Tier 2)
(State of Texas Mandatory Form)

Instructions: Please fill out all boxes. If zero use 0.

1. Total on lines 3, 10, 13, 18, 21, 40 and 51 Must be equal

2. Total on lines 27 and 30 Must equal 19

Gender:						
	1.	474	Female			
	2.	841	Male			
				3.	1315	Total
Race or Ethnicity:						
	4.	7	African			
	5.	2	Asian			
	6.	49	Caucasian			
	7.	1255	Hispanic			
	8.	2	Middle Eastern			
	9.	0	Native American			
				10.	1315	Total
Race or Ethnicity known prior to stop?						
	11.	1	Yes			
	12.	1314	No			
				13.	1315	Total
Reason for stop:						
	14.	1	Violation of law other than traffic			
	15.		Pre-existing knowledge (i.e. warrant)			
	16.	1089	Moving traffic violation			
	17.	225	Vehicle Traffic Violation (Equipment, Inspection			
				18.		Total 1,315

Racial Profiling Reporting
(Tier 2)

Search conducted?						
	19.	7	Yes			
	20.	1308	No			
				21.	1315	Total

Reason for search: (Choose 1 for each search)						
	22.	6	Consent			
	23.	0	Contraband/evidence in plain sight			
	24.	0	Probable cause or reasonable suspicion			
	25.	1	Inventory search performed as result of			
	26.	0	Incident to arrest/warrant			
	27.	7	Total Must equal #19			
Contraband discovered?						
	28.	0	Yes			
	29.	7	No			
	30.	7	Total Must equal #19			
Description of Contraband:						
	31.	0	Illegal drugs/drug paraphernalia			
	32.	0	Currency			
	33.	0	Weapons			
	34.	0	Alcohol			
	35.	0	Stolen property			
	36.	0	Other			
	37.	0	Total Must equal #28			
Arrest result of stop or search:						
	38.	5	Yes			
	39.	1310	No			
				40.	1315	Total

Arrest based on:						
	41.	5	Violation of the Penal Code			
	42.	3	Violation or a Traffic Law			
	43.		Violation of a City Ordinance			
	44.	9	Outstanding Warrant			
Street address or approximate location of the stop:						
	45.	164	City Street			
	46.	186	US Highway			
	47.	965	County Road			
	48.		Private Property or Other			
Written warning or a citation as a result of the stop:						
	49.	1312	Yes			
	50.	3	No			
				51.	1315	Total

Please submit electronically the analysis in PDF format required by 2.134 CCP(c) which contains:

- (1) a comparative analysis of the information compiled under Article 2.133 to:
 - (A) evaluate and compare the number of motor vehicle stops, within the applicable jurisdiction, of persons who are recognized as racial or ethnic minorities and persons who are not recognized as racial or ethnic minorities; and
 - (B) examine the disposition of motor vehicle stops made by officers employed by the agency, categorized according to the race or ethnicity of the affected persons, as appropriate, including any searches resulting from stops within the applicable jurisdiction; and

This analysis meets the above requirements	ATANACIO GAITAN	1-26-16
	Chief Administrator	Date

under Subsection (b)(7), the commission shall begin disciplinary procedures against the chief administrator.

Added by Acts 2001, 77th Leg., ch. 947, Sec. 1, eff. Sept. 1, 2001.

Amended by:

Acts 2009, 81st Leg., R.S., Ch. [1172](#), Sec. 25, eff. September 1, 2009.

Art. 2.133. REPORTS REQUIRED FOR MOTOR VEHICLE STOPS. (a) In this article, "race or ethnicity" has the meaning assigned by Article 2.132(a).

(b) A peace officer who stops a motor vehicle for an alleged violation of a law or ordinance shall report to the law enforcement agency that employs the officer information relating to the stop, including:

- (1) a physical description of any person operating the motor vehicle who is detained as a result of the stop, including:
 - (A) the person's gender; and
 - (B) the person's race or ethnicity, as stated by the person or, if the person does not state the person's race or ethnicity, as determined by the officer to the best of the officer's ability;
- (2) the initial reason for the stop;
- (3) whether the officer conducted a search as a result of the stop and, if so, whether the person detained consented to the search;
- (4) whether any contraband or other evidence was discovered in the course of the search and a description of the contraband or evidence;
- (5) the reason for the search, including whether:
 - (A) any contraband or other evidence was in plain view;
 - (B) any probable cause or reasonable suspicion existed to perform the search; or
 - (C) the search was performed as a result of the towing of the motor vehicle or the arrest of any person in the motor vehicle;
- (6) whether the officer made an arrest as a result of the

stop or the search, including a statement of whether the arrest was based on a violation of the Penal Code, a violation of a traffic law or ordinance, or an outstanding warrant and a statement of the offense charged;

(7) the street address or approximate location of the stop; and

(8) whether the officer issued a written warning or a citation as a result of the stop.

Added by Acts 2001, 77th Leg., ch. 947, Sec. 1, eff. Sept. 1, 2001.

Amended by:

Acts 2009, 81st Leg., R.S., Ch. [1172](#), Sec. 26, eff. September 1, 2009.

Art. 2.134. COMPILATION AND ANALYSIS OF INFORMATION COLLECTED.

(a) In this article:

(1) "Motor vehicle stop" has the meaning assigned by Article 2.132(a).

(2) "Race or ethnicity" has the meaning assigned by Article 2.132(a).

(b) A law enforcement agency shall compile and analyze the information contained in each report received by the agency under Article 2.133. Not later than March 1 of each year, each law enforcement agency shall submit a report containing the incident-based data compiled during the previous calendar year to the Commission on Law Enforcement Officer Standards and Education and, if the law enforcement agency is a local law enforcement agency, to the governing body of each county or municipality served by the agency.

(c) A report required under Subsection (b) must be submitted by the chief administrator of the law enforcement agency, regardless of whether the administrator is elected, employed, or appointed, and must include:

(1) a comparative analysis of the information compiled under Article 2.133 to:

(A) evaluate and compare the number of motor vehicle stops, within the applicable jurisdiction, of persons who are recognized as racial or ethnic minorities and persons who are not recognized as racial or ethnic minorities; and

AI-53032

Executive Office 7. A.

CC - REGULAR

Meeting Date: 01/26/2016

Submitted By: Monica Badillo, EXECUTIVE
OFFICE

Department: EXECUTIVE OFFICE

Information

CAPTION

Requesting approval to donate twenty-one (21) 1921 Old Jail and eighteen (18) 1985 Jail keys to the Museum of South Texas History.

BACKGROUND

Fiscal Impact

Attachments

[pic](#)

[pic](#)

[email](#)

Form Review

Inbox	Reviewed By	Date
Budget & Management	Veronica Ortiz	01/21/2016 10:12 AM
Purchasing Department	Monica Badillo	01/22/2016 04:11 PM
Form Started By: Monica Badillo		Started On: 01/19/2016 10:16 AM
Final Approval Date: 01/22/2016		





Zimbra**monica.badillo@co.hidalgo.tx.us**

Re: Old jail keys

From : Monica Badillo <monica.badillo@co.hidalgo.tx.us>

Tue, Jan 19, 2016 10:23 AM

Subject : Re: Old jail keys**To :** Daniel Flores <daniel.flores@co.hidalgo.tx.us>**Cc :** Stan Ramos <stan.ramos@co.hidalgo.tx.us>, Valde Guerra
<valde.guerra@co.hidalgo.tx.us>

Placed agenda item for next mtg.

Monica Salinas Badillo, Court Administrator
Hidalgo County Executive Office
2818 S. Bus. Hwy. 281
Edinburg, Texas 78539
(956) 292-7655 ext. 5602
(956) 292-7034 (fax)

----- Original Message -----

From: "Daniel Flores" <daniel.flores@co.hidalgo.tx.us>
To: "Stan Ramos" <stan.ramos@co.hidalgo.tx.us>, "Valde Guerra"
<valde.guerra@co.hidalgo.tx.us>
Cc: "Monica Badillo" <monica.badillo@co.hidalgo.tx.us>
Sent: Monday, January 11, 2016 10:44:11 AM
Subject: Old jail keys

Requesting that Hidalgo County donate the (21) 1921 Old Jail and the (18) 1985 Jail keys to South Texas Museum.

AI-53085

IT Department 9. A.

CC - REGULAR

Meeting Date: 01/26/2016

Submitted Renan Ramirez, IT DEPARTMENT

For:

Submitted By: Griselda Salazar, IT DEPARTMENT

Department: IT DEPARTMENT

Information

CAPTION

WIC PROGRAM:

Authorization and approval to purchase new wireless device with service through the County's membership/participation with CONTRACT: DIR-SDD-1779 for VERIZON WIRELESS for the following:

Qty:	Description:	Employee Name:	Service Plan:	Equipment:
1	Cell Phone	Office Use	America's Choice II 400 Share UNL. IN&N&W @ \$29.99 + \$5.00 taxes/fees = \$34.99 per month	Kyocera Dura XV+ @ \$0.

BACKGROUND

Fiscal Impact

Attachments

Backup

Form Review

Inbox	Reviewed By	Date
Purchasing Department	Monica Badillo	01/22/2016 04:11 PM
Form Started By: Griselda Salazar		Started On: 01/22/2016 03:38 PM
Final Approval Date: 01/22/2016		

WIRELESS DEVICE REQUEST FORM W.2011.2

TYPE OF REQUEST		
County Owned Wireless Device: <input checked="" type="checkbox"/> Office Use or <input type="checkbox"/> Individual <input type="checkbox"/> Name Change <input type="checkbox"/> Equipment Change <input type="checkbox"/> Plan Change <input type="checkbox"/> Delete Service	Wireless Data Device: <input type="checkbox"/> Data Card <input type="checkbox"/> Blackberry <input type="checkbox"/> Other:	Stipend: <input type="checkbox"/> Cellular Telephone \$50/mo <input type="checkbox"/> Data Pad \$25/mo

COUNTY OWNED WIRELESS DEVICE

Office Use / Employee: Office Use Employee ID#: _____ Signature: _____

Department: WIC Dept#: 350

Quantity: 1

Service: \$ 29.99 /mo (x) 9 months = 269.91 Account: 6-1292-441-00-350-017-6 -532

Service: \$ 5.00 /mo (x) 9 months = 45.00 Account: 6-1292-441-00-350-017-6 -532
6297664

Requisition Total: 314.91 Requisition Number: 291356

STIPEND

(1) Employee: _____ Employee ID#: _____ Signature: _____

Department: _____ Dept#: _____

Quantity: _____

Service: \$ _____ /mo (x) _____ months = _____ Account: _____ -532

Total: _____

(2) Elected Official/Department Head Authorization for Request:

Norma Longoria Norma Longoria 1/21/16

Signature _____ Print Name _____ Date _____

(3) Executive Office Authorization (Commissioner's Court Departments Only):

Valde Guerra Valde Guerra 1/22/16

Signature _____ Print Name _____ Date _____

(4) IT DEPARTMENT ONLY:

Service Type Codes: Americas Choice II 400 Share Unit @ 29.99 + 5.00
= 34.99/month

Commissioner's Court Action: _____ Commissioner's Court Date: 1/26/16

Approved Date: _____ Disapproved

Current County cell phone policy stipulates that employees that have cell phones assigned to them will be taxed the value of the service. Please see the following IRS document for more information: <http://www.irs.gov/govt/slg/article0,,id=167154,00.html>, EXAMPLE 2.

**Requisition
W.I.C. PROGRAM**

Req # 00291356

PO #

Date: 01/21/16

Bill To: x
x

Vendor : 287024
VERIZON WIRELESS
P.O. BOX 660108
DALLAS TX 75266-0108

Ship To: W.I.C. PROGRAM
3105 W. UNIVERSITY DR
EDINBURG TX 78539

Contact: MGONZALEZ
956-381-4646

Contract No:

Special Instructions:

QUANTITY	UOM	DESCRIPTION	UNIT PRICE	AMOUNT
		STATE OF TEXAS DIR CONTRACT NO# DIR SDD-1779 FOR WIRELESS VOICE, DATA SERVICES AND EQUIPMENT DO NOT DUPLICATE ORDER		
9.00	MONTH	AMERICA'S CHOICE II 400SHARE UNL IN & N&W DSICOUNTED MONTHLY ACCESS	29.99	269.91
9.00	MONTH	TAXES & FEES	5.00	45.00
		<u>Account No</u>	<u>Encumbrance</u>	
			Freight	.00
			Total	314.91
		LACTATION GRANT (17)		
		REPORT ROAD HAZARDS 1-866-HCR-SAFE OR 1-866-427-7233		

Authorized By: _____



QUOTE ID 15116121102
 DATE 11/6/2015
 TERM Annual (12 Months)
 PAGE 1 of 2

WIRELESS PROPOSAL FOR: Hidalgo County WIC
 SERVICE PLAN, CALLING FEATURES, AND EQUIPMENT QUOTES

RATE PLAN AND FEATURES

RATE PLAN - SHARE	Line Count	Discounted Monthly Access	Plan Included Minutes	Included TEXT / PIX / FLIX 200 (Tx/Pix/Flix)	Included Data N	Total Shared Minutes	Voice Overage	Monthly Cost	Term Cost
AMERICA'S CHOICE II 400 SHARE UNL IN & N&W \$38.45 0408	1	\$29.99	400			400	\$0.25	\$29.99	\$359.88
		\$0.00						\$0.00	\$0.00
		\$0.00						\$0.00	\$0.00
		\$0.00						\$0.00	\$0.00
		\$0.00						\$0.00	\$0.00
	1					400		\$29.99	\$359.88

RATE PLAN - NON SHARE	Line Count	Discounted Monthly Access	Plan Included Minutes	Included TEXT / PIX / FLIX	Included Data	Voice Overage	Monthly Cost	Term Cost
		\$0.00					\$0.00	\$0.00
		\$0.00					\$0.00	\$0.00
		\$0.00					\$0.00	\$0.00
		\$0.00					\$0.00	\$0.00
		\$0.00					\$0.00	\$0.00
		\$0.00					\$0.00	\$0.00

RATE PLAN - MOBILE BROADBAND	Line Count	Discounted Monthly Access	Included TEXT / PIX / FLIX	Included Data	Data Overage	Monthly Cost	Term Cost
		\$0.00				\$0.00	\$0.00
		\$0.00				\$0.00	\$0.00
		\$0.00				\$0.00	\$0.00
		\$0.00				\$0.00	\$0.00
		\$0.00				\$0.00	\$0.00
		\$0.00				\$0.00	\$0.00

RATE PLAN - MACHINE TO MACHINE	Line Count	Discounted Monthly Access	Included Data	Shared Data / Group	Data Overage	Monthly Cost	Term Cost
		\$0.00				\$0.00	\$0.00
		\$0.00				\$0.00	\$0.00
		\$0.00				\$0.00	\$0.00
		\$0.00				\$0.00	\$0.00
		\$0.00				\$0.00	\$0.00
		\$0.00				\$0.00	\$0.00

23% Discount applies to features of \$24.99 and higher when combined with rate plans of \$34.99 and higher.

FEATURES	Line Count	Discounted Monthly Access	Monthly Cost	Term Cost
		\$0.00	\$0.00	\$0.00
		\$0.00	\$0.00	\$0.00
		\$0.00	\$0.00	\$0.00
		\$0.00	\$0.00	\$0.00
		\$0.00	\$0.00	\$0.00
		\$0.00	\$0.00	\$0.00

EQUIPMENT AND ACCESSORIES

QUARTERLY DEVICE PROMOTIONS	Line Count	Cost per Unit	Subtotal
Kyocera Dura XV+ (PP \$14.99+)	1	\$0.00	\$0.00
		\$0.00	\$0.00
		\$0.00	\$0.00
		\$0.00	\$0.00
		\$0.00	\$0.00
		\$0.00	\$0.00
	1		\$0.00

DEVICE	Line Count	Cost per Unit	Subtotal
		\$0.00	\$0.00
		\$0.00	\$0.00
		\$0.00	\$0.00
		\$0.00	\$0.00
		\$0.00	\$0.00
		\$0.00	\$0.00
		\$0.00	\$0.00
		\$0.00	\$0.00

Eligible accessories receive a 35% discount

ACCESSORIES AND FULL-RETAIL (NO CONTRACT) EQUIPMENT	Line Count	Cost per Unit	Cost per Unit after Discount	Subtotal
				\$0.00
				\$0.00
				\$0.00
				\$0.00
				\$0.00
				\$0.00
				\$0.00

EQUIPMENT AND ACCESSORIES ESTIMATED COST \$0.00

INVESTMENT ESTIMATE	Monthly	Term Total
RATE PLAN AND FEATURES ESTIMATED COST FOR TERM [Annual (12 Months)]:	\$29.99	\$359.88
EQUIPMENT AND ACCESSORIES ESTIMATED COST:		\$0.00
INVESTMENT TOTAL		\$359.88

4Q15 BUSINESS BILL INCENTIVE CREDIT (BIC) PROMOTIONS	Line Count	BIC Amount	BIC Total
		\$0.00	\$0.00
		\$0.00	\$0.00
		\$0.00	\$0.00
		\$0.00	\$0.00
		\$0.00	\$0.00
		\$0.00	\$0.00

QUOTE ID 15116121102

Additional Notes:

- * Charge does not include roaming charges, minutes used over allowance, etc. Please consult with your Sales Representative for more information.
- ** Equipment pricing and availability is subject to change.
- *** All applicable price plan and feature discounts have already been applied

Service Pricing provided is for Government Liability Accounts Only and is subject to the terms, provisions and conditions of the State of Texas Department of Information Resources (DIR) Contract No. DIR-SDD-1779 Coverage, service and offers not available in all areas. Full terms and conditions, along with additional price plans offered by Verizon Wireless can be found on the <http://www.dir.state.tx.us/> internet website. Price quotes do not reflect Federal Universal Service, E911 and Regulatory Fees, charges, or pass-through assessments. Please see information on Regulatory Surcharges and Fees below for additional details.

All quotes contained in this proposal are subject to the terms and conditions of the State of Texas DIR contract. Your accounts must be in good standing with Verizon wireless to migrate your existing lines of service to the pricing offered in this proposal if your Agency currently has service with Verizon Wireless.

Price Plan changes and discounts may take up to two bill cycles to appear on your Verizon Wireless billing statement for accounts transitioning to an approved State of Texas contract vehicle. As part of our compliance with FCC requirements, Verizon Wireless allows only GPS-compliant devices to be activated on our network. If your current device is not GPS-compliant you will not be able to activate service on our network with your existing equipment.

This Quotation is valid for ninety (90) days from date listed on quote (except for promotional pricing which may expire sooner). Data furnished in this document shall not be duplicated, used, or disclosed in whole or in part for any purpose other than to evaluate the document.

AI-52929

IT Department 9. B.

CC - REGULAR

Meeting Date: 01/26/2016

Submitted By: Griselda Salazar, IT DEPARTMENT

Department: IT DEPARTMENT

Information

CAPTION

FIRE MARSHAL/PLANNING DEPT.:

Authorization and approval to upgrade wireless equipment, downgrade service plan and change assigned name on devices through the County's membership/participation with CONTRACT: DIR-SDD-1779 for VERIZON WIRELESS for the following:

Qty:	Description:	Employee Name/ID:	Service Plan:	Equipment:	MDN:
6	Downgrade Service Plan and Upgrade Equipment	See Attachment	America's Choice II 400 Share Email & Data+N&W IN UNL @ \$49.99 + \$5.00 taxes/fees = \$54.99/ea per month	iPhone 5s 16GB	See Attachment
8	Upgrade Equipment	See Attachment	4G Mobile Broadband UNL @ \$37.99/ea per month	Verizon AC791L	See Attachment
Department:	Description:	Employee Name/ID:	Transfer To:	Device:	MDN:
Fire Marshal	Name Change	Kyle Pulley/203742	Office Use	Cell Phone	956-929-6497
Fire Marshal	Name Change	Juan Martinez/138126	Office Use	Data Card	956-342-3707
Fire Marshal	Name Change	Kyle Pulley/203742	Office Use	Data Card	956-342-3675
Planning	Name Change	Eli Villegas/185817	Office Use	Cell Phone	956-358-8579

BACKGROUND

Fiscal Impact

FISCAL YEAR: 2016 ACCT. #: 6-1100-422-10-300-001-0-532
 FUNDS AVAILABLE Y/N?: Y MATCHING FUNDS Y/N?:

BUDGETARY IMPACT:

Funds available as of 1/15/16

Attachments

Equipment List

Verizon Quote

Request Forms iPhones

Request Forms Data Cards

Planning Request Forms

FM Requisition

Form Review

Inbox	Reviewed By	Date
Budget & Management	Debbie Tamez	01/15/2016 05:07 PM
Purchasing Department	Monica Badillo	01/22/2016 04:11 PM
Form Started By: Griselda Salazar		Started On: 01/12/2016 05:37 PM
Final Approval Date: 01/22/2016		

MDN	Device Model	Contact Name	Employee ID
956-227-7024	iPhone 5s 16GB	TOMMY URESTE	126403
956-289-3873	iPhone 5s 16GB	ERIC SANCHEZ	193593
956-393-1848	iPhone 5s 16GB	JOHN FRANZ	201073
956-929-6497	iPhone 5s 16GB	OFFICE USE (VACANT)	N/A
956-929-6675	iPhone 5s 16GB	MEDARDO VILLARREAL	202541
956-289-3857	iPhone 5s 16GB	VICTOR RAMIREZ	201103
956-342-2162	Verizon AC791L	ERIC SANCHEZ	193593
956-342-2165	Verizon AC791L	VICTOR RAMIREZ	201103
956-342-2607	Verizon AC791L	TOMMY URESTE	126403
956-342-3675	Verizon AC791L	OFFICE USE (VACANT)	N/A
956-342-3707	Verizon AC791L	OFFICE USE (VACANT)	N/A
956-342-3895	Verizon AC791L	MEDARDO VILLARREAL	202541
956-342-3939	Verizon AC791L	OFFICE USE	N/A
956-929-2652	Verizon AC791L	JOHN FRANZ	201073



**Wireless Telecom Proposal for:
State of Texas DIR Contract No. DIR-SDD-1779 for Wireless Voice, Data Services and Equipment**

Date: January 6, 2016

Customer Name: Hidalgo County Fire Marshal

Sales Representative: Carlos Zavala

*Pricing provided is for Government Liability Accounts Only and is subject to the terms, provisions and conditions of the Contract for Wireless Voice & Data Services and Equipment between State of Texas, Department of Information Resources and Verizon Wireless, DIR Contract No. DIR-SDD-1779. Full terms and conditions, along with additional information and ordering instructions can be found on the Internet website at: <http://www.dir.state.tx.us/store/tsd/telephony/wireless.htm#cing>
Prices quoted do not reflect applicable fees, charges, or pass-through assessments.
This Quotation is valid for ninety (90) days from date listed on quote (except for promotional pricing which may expire sooner). Data furnished in this document shall not be duplicated, used, or disclosed in whole or in part for any purpose other than to evaluate the document.*

EQUIPMENT AND ACCESSORIES

QUARTERLY DEVICE PROMOTIONS	Line Count	Cost per Unit	Subtotal
iPhone 5s 16GB (PP \$20+, plus required BB/PDA bolt on feature)	6	\$0.00	\$0.00
Verizon AC791L (PP \$24.99+)	8	\$0.00	\$0.00
		\$0.00	\$0.00
		\$0.00	\$0.00
		\$0.00	\$0.00
		\$0.00	\$0.00
	14		\$0.00

DEVICE	Line Count	Cost per Unit	Subtotal
		\$0.00	\$0.00
		\$0.00	\$0.00
		\$0.00	\$0.00
		\$0.00	\$0.00
		\$0.00	\$0.00
		\$0.00	\$0.00
		\$0.00	\$0.00
		\$0.00	\$0.00

Eligible accessories receive a 35% discount

ACCESSORIES AND FULL-RETAIL (NO CONTRACT) EQUIPMENT	Line Count	Cost per Unit	Cost per Unit after Discount	Subtotal
				\$0.00
				\$0.00
				\$0.00
				\$0.00
				\$0.00
				\$0.00
				\$0.00

EQUIPMENT AND ACCESSORIES ESTIMATED COST \$0.00

INVESTMENT ESTIMATE	Monthly	Term Total
RATE PLAN AND FEATURES ESTIMATED COST FOR TERM [Annual (12 Months)]:	\$603.86	\$7,246.32
EQUIPMENT AND ACCESSORIES ESTIMATED COST:		\$0.00
INVESTMENT TOTAL		\$7,246.32

1Q16 BUSINESS BILL INCENTIVE CREDIT (BIC) PROMOTIONS	Line Count	BIC Amount	BIC Total
		\$0.00	\$0.00
		\$0.00	\$0.00
		\$0.00	\$0.00
		\$0.00	\$0.00
		\$0.00	\$0.00
		\$0.00	\$0.00

QUOTE ID 1616153140

Additional Notes:

- * Charge does not include roaming charges, minutes used over allowance, etc. Please consult with your Sales Representative for more information.
- ** Equipment pricing and availability is subject to change.
- *** All applicable price plan and feature discounts have already been applied

Service Pricing provided is for Government Liability Accounts Only and is subject to the terms, provisions and conditions of the State of Texas Department of Information Resources (DIR) Contract No. DIR-SDD-1779 Coverage, service and offers not available in all areas. Full terms and conditions, along with additional price plans offered by Verizon Wireless can be found on the <http://www.dir.state.tx.us/> internet website. Price quotes do not reflect Federal Universal Service, E911 and Regulatory Fees, charges, or pass-through assessments. Please see information on Regulatory Surcharges and Fees below for additional details.

All quotes contained in this proposal are subject to the terms and conditions of the State of Texas DIR contract. Your accounts must be in good standing with Verizon wireless to migrate your existing lines of service to the pricing offered in this proposal if your Agency currently has service with Verizon Wireless.

Price Plan changes and discounts may take up to two bill cycles to appear on your Verizon Wireless billing statement for accounts transitioning to an approved State of Texas contract vehicle. As part of our compliance with FCC requirements, Verizon Wireless allows only GPS-compliant devices to be activated on our network. If your current device is not GPS-compliant you will not be able to activate service on our network with your existing equipment.

This Quotation is valid for ninety (90) days from date listed on quote (except for promotional pricing which may expire sooner). Data furnished in this document shall not be duplicated, used, or disclosed in whole or in part for any purpose other than to evaluate the document.



WIRELESS DEVICE REQUEST FORM W.2011.2

TYPE OF REQUEST

County Owned Wireless Device:

Office Use or Individual

Name Change

Equipment Change

Plan Change

Delete Service

Wireless Data Device:

Data Card

Blackberry

Other: I phone

Stipend:

Cellular Telephone \$50/mo

Data Pad \$25/mo

COUNTY OWNED WIRELESS DEVICE

Office Use / Employee: Eric Sanchez Employee ID# 193593 Signature: [Signature]

Department: Fire Marshal Depth: 300

Quantity: 1 price 289.3873

Service: \$ 49.99 /mo (x) 11 months = 549.89 Account: 6-1100-422-10-300-001-0-532

Service: \$ 5.00 /mo (x) 11 months = 55.00 Account: 6-1100-422-10-300-001-0-532-6297604

Requisition Total: 7832.30 Requisition Number: 290426

STIPEND

(1) Employee: _____ Employee ID# _____ Signature: _____

Department: _____ Depth: _____

Quantity: _____

Service: \$ _____ /mo (x) _____ months = _____ Account: _____ -532

Total: _____

(2) Elected Official/Department Head Authorization for Request:

[Signature] Eric Ande 11/11/16

Signature Print Name Date

(3) Executive Office Authorization (Commissioner's Court Departments Only):

[Signature] Valde Guerra 1/15/16

Signature Print Name Date

(4) IT DEPARTMENT ONLY:

Service Type Codes: America's Choice II 400 Share Email & Data + VAWT IN Uni.

49.99 + 5.00 txs/fees = 54.99 month

Commissioner's Court Action: _____ Commissioner's Court Date: 2/2/16

Approved Date: _____ Disapproved

Current County cell phone policy stipulates that employees that have cell phones assigned to them will be taxed the value of the service. Please see the following IRS document for more information: <http://www.irs.gov/govt/irs/article0..id=167154,00.html>, EXAMPLE 2.

WIRELESS DEVICE REQUEST FORM W.2011.2

TYPE OF REQUEST		
County Owned Wireless Device: <input type="checkbox"/> Office Use or <input checked="" type="checkbox"/> Individual <input type="checkbox"/> Name Change <input checked="" type="checkbox"/> Equipment Change <input checked="" type="checkbox"/> Plan Change <input type="checkbox"/> Delete Service	Wireless Data Device: <input type="checkbox"/> Data Card <input type="checkbox"/> Blackberry <input checked="" type="checkbox"/> Other: <u>iPhone</u>	Stipend: <input type="checkbox"/> Cellular Telephone \$50/mo <input type="checkbox"/> Data Pad \$25/mo

COUNTY OWNED WIRELESS DEVICE

Office Use / Employee: Victor Ramirez Employee ID# 201103 Signature:

Department: Fire Marshal Dept#: 300

Quantity: 1 950-289-3857

Service: \$49.99/mo (x) 11 months = \$549.89 Account: 61100-422-10-300-001-0-532

Service: \$5.00/mo (x) 11 months = 55.00 Account: 61100-422-10-300-001-0-532

Requisition Total: 7932.30 Requisition Number: 290426

STIPEND

(1) Employee: _____ Employee ID# _____ Signature: _____

Department: _____ Dept#: _____

Quantity: _____

Service: \$ _____ /mo (x) _____ months = _____ Account: _____ -532

Total: _____

(2) Elected Official/Department Head Authorization for Request:

Eric Archer 11-11-16

Signature Print Name Date

(3) Executive Office Authorization (Commissioner's Court Departments Only):

Valde Guerra 1/15/16

Signature Print Name Date

(4) IT DEPARTMENT ONLY:

Service Type Codes: Americas Choice II 400 Share Emailed Data + N&W + IN UNL

@ 49.99 + 500 = 54.99 month

Commissioner's Court Action: _____ Commissioner's Court Date: 2/2/16

Approved Date: _____ Disapproved

Current County cell phone policy stipulates that employees that have cell phones assigned to them will be taxed the value of the service. Please see the following IRS document for more information: <http://www.irs.gov/efile/article/0,id=167154,00.html>, EXAMPLE 2.



WIRELESS DEVICE REQUEST FORM W.2011.2

TYPE OF REQUEST

County Owned Wireless Device:

- Office Use or Individual
- Name Change
- Equipment Change
- Plan Change
- Delete Service

Wireless Data Device:

- Data Card
- Blackberry
- Other: iPhone

Stipend:

- Cellular Telephone \$50/mo
- Data Pad \$25/mo

COUNTY OWNED WIRELESS DEVICE

Office Use/ Employee: Tommy Ureste Employee ID# 126103 Signature:

Department: Fire Marshal Dept#: 300

Quantity: 1 950-227-7024

Service: \$ 49.99 /mo (x) 11 months = 549.89 Account: 6-1100-422-10-300-001-0-532

Service: \$ 5.00 /mo (x) 11 months = 55.00 Account: 6-1100-422-10-300-001-0-532

Requisition Total: 7832.30 Requisition Number: 290420

STIPEND

(1) Employee: _____ Employee ID# _____ Signature: _____

Department: _____ Dept#: _____

Quantity: _____

Service: \$ _____ /mo (x) _____ months = _____ Account: _____ -532

Total: _____

(2) Elected Official/Department Head Authorization for Request:

Eric Sanchez 11-01-16
Signature Print Name Date

(3) Executive Office Authorization (Commissioner's Court Departments Only):

Valde Guerra 1/15/16
Signature Print Name Date

(4) IT DEPARTMENT ONLY:

Service Type Codes: America's Choice #1400 Share Email & Data + NEW+IN Intl.
@ 49.99 + 5.00 = 54.99 month

Commissioner's Court Action: _____ Commissioner's Court Date: 2/2/16

Approved Date: _____ Disapproved

Current County cell phone policy stipulates that employees that have cell phones assigned to them will be taxed the value of the service. Please see the following IRS document for more information: <http://www.irs.gov/pub/irs/ig/article0,,id=167154,00.html>, EXAMPLE 2.

WIRELESS DEVICE REQUEST FORM W.2011.2

TYPE OF REQUEST		
County Owned Wireless Device: <input type="checkbox"/> Office Use or <input checked="" type="checkbox"/> Individual <input type="checkbox"/> Name Change <input checked="" type="checkbox"/> Equipment Change <input checked="" type="checkbox"/> Plan Change <input type="checkbox"/> Delete Service	Wireless Data Device: <input type="checkbox"/> Data Card <input type="checkbox"/> Blackberry <input checked="" type="checkbox"/> Other: <u>I phone</u>	Stipend: <input type="checkbox"/> Cellular Telephone \$50/mo <input type="checkbox"/> Data Pad \$25/mo

COUNTY OWNED WIRELESS DEVICE

Office Use / Employee: John Franz Employee ID# 2010173 Signature:

Department: Fire Marshal Dept#: 300

Quantity: 1 950-393-1848

Service: \$ 49.99 /mo (x) 11 months = \$549.89 Account: 0-1100-422-10-300-001-0-532

Service: \$ 5.00 /mo (x) 11 months = 55.00 Account: 0-1100-422-10-300-001-0-532

Requisition Total: 7832.30 Requisition Number: 0910426

STIPEND

(1) Employee: _____ Employee ID# _____ Signature: _____

Department: _____ Dept#: _____

Quantity: _____

Service: \$ _____ /mo (x) _____ months = _____ Account: _____ -532

Total: _____

(2) Elected Official/Department Head Authorization for Request:

Eric Sander 01.11.10

Signature Print Name Date

(3) Executive Office Authorization (Commissioner's Court Departments Only):

Valde Guerra 1/15/10

Signature Print Name Date

(4) IT DEPARTMENT ONLY:

Service Type Codes: America's Choice \$4.00 Share Email & Data + NEW + IN unl.

@ .49.99 + 5.00 = 54.99 month

Commissioner's Court Action: _____ Commissioner's Court Date: 2/2/10

Approved Date: _____ Disapproved

Current County cell phone policy stipulates that employees that have cell phones assigned to them will be taxed the value of the service. Please see the following IRS document for more information: <http://www.irs.gov/govtstg/article/0,,id=167154,00.html>, EXAMPLE 2.

Revised: 03/09/2011



WIRELESS DEVICE REQUEST FORM W.2011.2

TYPE OF REQUEST		
County Owned Wireless Device: <input type="checkbox"/> Office Use or <input checked="" type="checkbox"/> Individual <input type="checkbox"/> Name Change <input checked="" type="checkbox"/> Equipment Change <input checked="" type="checkbox"/> Plan Change <input type="checkbox"/> Delete Service	Wireless Data Device: <input type="checkbox"/> Data Card <input type="checkbox"/> Blackberry <input checked="" type="checkbox"/> Other: <u>I phone</u>	Stipend: <input type="checkbox"/> Cellular Telephone \$50/mo <input type="checkbox"/> Data Pad \$25/mo

COUNTY OWNED WIRELESS DEVICE

Office Use/ Employee: Medardo Villarreal Employee ID#: 202541 Signature: [Signature]

Department: Fire Marshal Dept#: 300

Quantity: 1 956-929-16675

Service: \$ 49.99 /mo (x) 11 months = 549.89 Account: 6-1100-422-10-300-001-0-532

Service: \$ 5.00 /mo (x) 11 months = 55.00 Account: 6-1100-422-10-300-001-0-532

Requisition Total: 7832.30 Requisition Number: 270426

STIPEND

(1) Employee: _____ Employee ID#: _____ Signature: _____

Department: _____ Dept#: _____

Quantity: _____

Service: \$ _____ /mo (x) _____ months = _____ Account: _____ -532

Total: _____

(2) Elected Official/Department Head Authorization for Request:

[Signature] Eric Sanchez 01.11.16

Signature Print Name Date

(3) Executive Office Authorization (Commissioner's Court Departments Only):

[Signature] Valde Guerra 1/15/16

Signature Print Name Date

(4) IT DEPARTMENT ONLY:

Service Type Codes: America's Choice TL 400 Share, Email & Data + NEW + IN Unit.
@ .49.99 + 5.00 = 54.99 month

Commissioner's Court Action: _____ Commissioner's Court Date: 2/2/16

Approved Date: _____ Disapproved

Current County call phone policy stipulates that employees that have call phones assigned to them will be taxed the value of the service. Please see the following IRS document for more information: <http://www.irs.gov/govt/sfp/article/0,,id=167164,00.html>, EXAMPLE 2.

WIRELESS DEVICE REQUEST FORM W.2011.2

TYPE OF REQUEST		
County Owned Wireless Device: <input type="checkbox"/> Office Use or <input type="checkbox"/> Individual <input checked="" type="checkbox"/> Name Change <input checked="" type="checkbox"/> Equipment Change <input checked="" type="checkbox"/> Plan Change <input type="checkbox"/> Delete Service	Wireless Data Device: <input type="checkbox"/> Data Card <input type="checkbox"/> Blackberry <input checked="" type="checkbox"/> Other: <u>iPhone</u>	Stipend: <input type="checkbox"/> Cellular Telephone \$50/mo <input type="checkbox"/> Data Pad \$25/mo

COUNTY OWNED WIRELESS DEVICE

Office Use / Employee: Office Use Employee ID#: _____ Signature: _____
 Department: Fire Marshal Dept#: 300
 Quantity: 1 950-929-6497
 Service: \$ 49.99 /mo (x) 11 months = \$549.89 Account: 6-1100-422-10-300-001-0-532
 Service: \$ 5.00 /mo (x) 11 months = 55.00 Account: 6-1100-422-10-300-001-0-532-619/664
 Requisition Total: 5832.30 Requisition Number: 290426

STIPEND

(1) Employee: _____ Employee ID# _____ Signature: _____
 Department: _____ Dept#: _____
 Quantity: _____
 Service: \$ _____ /mo (x) _____ months = _____ Account: _____ -532
 Total: _____

(2) Elected Official/Department Head Authorization for Request:

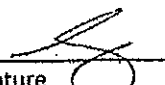
S  ERIC SANCHEZ 01.11.
 Signature Print Name Date

(3) Executive Office Authorization (Commissioner's Court Departments Only):

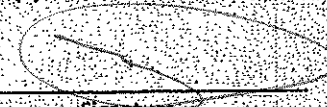
 Valde Guerra 1/15/16
 Signature Print Name Date

(4) IT DEPARTMENT ONLY:

Service Type Codes: America's Choice II 400 Shave Email & Data + NEW + IN Uni.
@ 49.99 + 5.00 = 54.99 Month.

Commissioner's Court Action: _____ Commissioner's Court Date: 2/2/16
 Approved Date: _____ Disapproved

Current County cell phone policy stipulates that employees that have cell phones assigned to them will be taxed the value of the service. Please see the following IRS document for more information: <http://www.irs.gov/govt/irsig/article/0,,id=167154,00.html>, EXAMPLE 2.

Revised: 03/09/2011



WIRELESS DEVICE REQUEST FORM W.2011.2

TYPE OF REQUEST		
County Owned Wireless Device: <input type="checkbox"/> Office Use or <input checked="" type="checkbox"/> Individual <input checked="" type="checkbox"/> Name Change <input checked="" type="checkbox"/> Equipment Change <input checked="" type="checkbox"/> Plan Change <input type="checkbox"/> Delete Service	Wireless Data Device: <input type="checkbox"/> Data Card <input type="checkbox"/> Blackberry <input checked="" type="checkbox"/> Other: <u>iPhone</u>	Stipend: <input type="checkbox"/> Cellular Telephone \$50/mo <input type="checkbox"/> Data Pad \$25/mo
COUNTY OWNED WIRELESS DEVICE		
Office Use / Employee: <u>Kyle Pullen</u>	Employee ID# <u>203742</u>	Signature: _____
Department: <u>Fire Marshal</u>	Dept# <u>300</u>	<u>No longer employed (ES)</u>
Quantity: <u>950-929-6497</u>		
Service: \$ _____ /mo (x) _____ months = _____	Account: _____	<u>532</u>
Service: \$ _____ /mo (x) _____ months = _____	Account: _____	<u>19/604</u>
Requisition Total: _____	Requisition Number: _____	
STIPEND		
(1) Employee: _____	Employee ID# _____	Signature: _____
Department: _____	Dept# _____	
Quantity: _____		
Service: \$ _____ /mo (x) _____ months = _____	Account: _____	<u>532</u>
Total: _____		
(2) Elected Official/Department Head Authorization for Request:		
<u>[Signature]</u>	<u>ERIC SANDER</u>	<u>01.11.16</u>
Signature	Print Name	Date
(3) Executive Office Authorization (Commissioner's Court Departments Only):		
<u>[Signature]</u>	<u>Valde Guerra</u>	<u>1/15/16</u>
Signature	Print Name	Date
(4) IT DEPARTMENT ONLY:		
Service Type Codes: <u>Change name to Office Use.</u>		

Commissioner's Court Action:

Commissioner's Court Date: 2/2/16

Approved Date: _____

Disapproved

Current County cell phone policy stipulates that employees that have cell phones assigned to them will be taxed the value of the service. Please see the following IRS document for more information: http://www.irs.gov/ustg/article/0_id=167154,00.html, EXAMPLE 2.

WIRELESS DEVICE REQUEST FORM W.2011.2

TYPE OF REQUEST		
County Owned Wireless Device: <input type="checkbox"/> Office Use or <input checked="" type="checkbox"/> Individual <input type="checkbox"/> Name Change <input checked="" type="checkbox"/> Equipment Change <input type="checkbox"/> Plan Change <input type="checkbox"/> Delete Service	Wireless Data Device: <input checked="" type="checkbox"/> Data Card <input type="checkbox"/> Blackberry <input type="checkbox"/> Other:	Stipend: <input type="checkbox"/> Cellular Telephone \$50/mo <input type="checkbox"/> Data Pad \$25/mo
COUNTY OWNED WIRELESS DEVICE		
Office Use/ Employee: <u>Victor Ramirez</u> Employee ID# <u>201103</u> Signature:		
Department: <u>Fire Marshal</u> Dept#: <u>300</u>		
Quantity: <u>1</u> <u>956-342-2165</u>		
Service: \$ <u>37.99</u> /mo (x) <u>11</u> months = <u>417.89</u> Account: <u>10-1100-422-10-300-001-9</u> <u>532</u>		
Service: \$ _____ /mo (x) _____ months = _____ Account: _____ <u>-619/664</u>		
Requisition Total: <u>7832.30</u> Requisition Number: <u>290426</u>		
STIPEND		
(1) Employee: _____ Employee ID# _____ Signature: _____		
Department: _____ Dept#: _____		
Quantity: _____		
Service: \$ _____ /mo (x) _____ months = _____ Account: _____ <u>532</u>		
Total: _____		
(2) Elected Official/Department Head Authorization for Request:		
	<u>ERIC SANDER</u> Print Name	<u>01-11-10</u> Date
(3) Executive Office Authorization (Commissioner's Court Departments Only):		
	<u>Valde Guerra</u> Print Name	<u>1/15/16</u> Date
(4) IT DEPARTMENT ONLY:		
Service Type Codes: <u>4G Mobile Broadband Unt. @ 37.99 mo</u>		

Commissioner's Court Action: _____ Commissioner's Court Date: 2/2/16

Approved Date: _____ Disapproved

Current County cell phone policy stipulates that employees that have cell phones assigned to them will be taxed the value of the service. Please see the following IRS document for more information: <http://www.irs.gov/govt/sig/article/0,,id=167154,00.html>, EXAMPLE 2.



WIRELESS DEVICE REQUEST FORM W.2011.2

TYPE OF REQUEST

County Owned Wireless Device:
 Office Use or Individual
 Name Change
 Equipment Change
 Plan Change
 Delete Service

Wireless Data Device:
 Data Card
 Blackberry
 Other:

Stipend:
 Cellular Telephone \$50/mo
 Data Pad \$25/mo

COUNTY OWNED WIRELESS DEVICE

Office Use / Employee: Eric Sanchez Employee ID# 193593 Signature: [Signature]
 Department: Fire Marshal Dept#: 300
 Quantity: 1 950-342-2162
 Service: \$ 37.99 /mo (x) 11 months = \$ 417.89 Account: 6-100-422-10-300-001-0 -532
 Service: \$ _____ /mo (x) _____ months = _____ Account: _____ -619/664
 Requisition Total: 7832.30 Requisition Number: 290426

STIPEND

(1) Employee: _____ Employee ID# _____ Signature: _____
 Department: _____ Dept#: _____
 Quantity: _____
 Service: \$ _____ /mo (x) _____ months = _____ Account: _____ -532
 Total: _____

(2) Elected Official/Department Head Authorization for Request:

[Signature] Eric Sanchez 01-11-16
 Signature Print Name Date

(3) Executive Office Authorization (Commissioner's Court Departments Only):

[Signature] Valde Guerra 1/15/16
 Signature Print Name Date

(4) IT DEPARTMENT ONLY:

Service Type Codes: 4G Mobile Broadband Int. @ 37.99 mo

Commissioner's Court Action: _____ Commissioner's Court Date: 2/2/16

Approved Date: _____ Disapproved

Current County cell phone policy stipulates that employees that have cell phones assigned to them will be taxed the value of the service. Please see the following IRS document for more information: <http://www.irs.gov/govt/istg/article0,,id=167154,00.html>, EXAMPLE 2.

WIRELESS DEVICE REQUEST FORM W.2011.2

TYPE OF REQUEST		
County Owned Wireless Device: <input type="checkbox"/> Office Use or <input checked="" type="checkbox"/> Individual <input type="checkbox"/> Name Change <input checked="" type="checkbox"/> Equipment Change <input type="checkbox"/> Plan Change <input type="checkbox"/> Delete Service	Wireless Data Device: <input checked="" type="checkbox"/> Data Card <input type="checkbox"/> Blackberry <input type="checkbox"/> Other:	Stipend: <input type="checkbox"/> Cellular Telephone \$50/mo <input type="checkbox"/> Data Pad \$25/mo

COUNTY OWNED WIRELESS DEVICE

Office Use / Employee: Tommy Ureste Employee ID# 126403 Signature:

Department: Fire Marshal Dept#: 300

Quantity: 1 956-342-2607

Service: \$ 37.99 /mo (x) 11 months = 417.89 Account: 6-1100-422-10-300-001-D -532

Service: \$ _____ /mo (x) _____ months = _____ Account: _____ -619/664

Requisition Total: 7832.30 Requisition Number: 290420

STIPEND

(1) Employee: _____ Employee ID# _____ Signature: _____

Department: _____ Dept#: _____

Quantity: _____

Service: \$ _____ /mo (x) _____ months = _____ Account: _____ -532

Total: _____

(2) Elected Official/Department Head Authorization for Request:

Eric Sanchez 01/11/16

Signature Print Name Date

(3) Executive Office Authorization (Commissioner's Court Departments Only):

Valde Guerra 1/15/16

Signature Print Name Date

(4) IT DEPARTMENT ONLY:

Service Type Codes: 4G Mobile Broadband Uni. @ 37.99 mo

Commissioner's Court Action: _____ Commissioner's Court Date: 2/2/16

Approved Date: _____ Disapproved

Current County cell phone policy stipulates that employees that have cell phones assigned to them will be taxed the value of the service. Please see the following IRS document for more information: <http://www.irs.gov/govtsig/article/0,,id=167164,00.html>, EXAMPLE 2.

Revised: 03/09/2011



WIRELESS DEVICE REQUEST FORM W.2011.2

TYPE OF REQUEST

County Owned Wireless Device:
 Office Use or Individual
 Name Change
 Equipment Change
 Plan Change
 Delete Service

Wireless Data Device:
 Data Card
 Blackberry
 Other:

Stipend:
 Cellular Telephone \$50/mo
 Data Pad \$25/mo

COUNTY OWNED WIRELESS DEVICE

Office Use / Employee: Medardo Villarreal Employee ID# 202541 Signature: [Signature]
 Department: Fire Marshal Dept# 300
 Quantity: 1 956342-3895
 Service: \$ 2799 /mo (x) 11 months = 44789 Account: 1-1100-421-10-300-001-0-532
 Service: \$ _____ /mo (x) _____ months = _____ Account: _____ -619/664
 Requisition Total: 7832.30 Requisition Number: 290420

STIPEND

(1) Employee: _____ Employee ID# _____ Signature: _____
 Department: _____ Dept# _____
 Quantity: _____
 Service: \$ _____ /mo (x) _____ months = _____ Account: _____ -532
 Total: _____

(2) Elected Official/Department Head Authorization for Request:

[Signature] ERIC SANDER 01/11/16
 Signature Print Name Date

(3) Executive Office Authorization (Commissioner's Court Departments Only):

[Signature] Valde Guerra 1/15/16
 Signature Print Name Date

(4) IT DEPARTMENT ONLY:

Service Type Codes: 4G Mobile Broadband Unit @ 37.99 mo



Commissioner's Court Action: _____ Commissioner's Court Date: 2/2/16

Approved Date: _____ Disapproved

Current County cell phone policy stipulates that employees that have cell phones assigned to them will be taxed the value of the service. Please see the following IRS document for more information: <http://www.irs.gov/govt/sg/article0,,id=167164,00.html>, EXAMPLE 2.

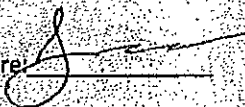

WIRELESS DEVICE REQUEST FORM W.2011.2

TYPE OF REQUEST		
County Owned Wireless Device: <input type="checkbox"/> Office Use or <input checked="" type="checkbox"/> Individual <input type="checkbox"/> Name Change <input checked="" type="checkbox"/> Equipment Change <input type="checkbox"/> Plan Change <input type="checkbox"/> Delete Service	Wireless Data Device: <input checked="" type="checkbox"/> Data Card <input type="checkbox"/> Blackberry <input type="checkbox"/> Other:	Stipend: <input type="checkbox"/> Cellular Telephone \$50/mo <input type="checkbox"/> Data Pad \$25/mo
COUNTY OWNED WIRELESS DEVICE		
Office Use / Employee: <u>John Franz</u> Employee ID# <u>201073</u> Signature: 		
Department: <u>Fire Marshal</u> Dept#: <u>300</u>		
Quantity: <u>1</u> <u>999-999-21052</u>		
Service: \$ <u>37.99</u> /mo (x) <u>11</u> months = <u>417.89</u> Account: <u>10-1100-422-10-3-00-001-0</u> -532		
Service: \$ _____ /mo (x) _____ months = _____ Account: _____ -619/664		
Requisition Total: <u>7832.30</u> Requisition Number: <u>29,0426</u>		
STIPEND		
(1) Employee: _____ Employee ID# _____ Signature: _____		
Department: _____ Dept#: _____		
Quantity: _____		
Service: \$ _____ /mo (x) _____ months = _____ Account: _____ -532		
Total: _____		
(2) Elected Official/Department Head Authorization for Request:		
	<u>Eric Sander</u>	<u>11-11-16</u>
Signature	Print Name	Date
(3) Executive Office Authorization (Commissioner's Court Departments Only):		
	<u>Valde Guerra</u>	<u>1/15/16</u>
Signature	Print Name	Date
(4) IT DEPARTMENT ONLY:		
Service Type Codes: <u>4G Mobile Broadband Unl @ 37.99 mo</u>		

Commissioner's Court Action:

Commissioner's Court Date: 2/2/16

Approved Date: _____

Disapproved

Current County cell phone policy stipulates that employees that have cell phones assigned to them will be taxed the value of the service. Please see the following IRS document for more information: <http://www.irs.gov/govt/sig/article/0,,id=167164,00.html>, EXAMPLE 2.

WIRELESS DEVICE REQUEST FORM W.2011.2

TYPE OF REQUEST		
County Owned Wireless Device: <input checked="" type="checkbox"/> Office Use or <input type="checkbox"/> Individual <input type="checkbox"/> Name Change <input checked="" type="checkbox"/> Equipment Change <input type="checkbox"/> Plan Change <input type="checkbox"/> Delete Service	Wireless Data Device: <input checked="" type="checkbox"/> Data Card <input type="checkbox"/> Blackberry <input type="checkbox"/> Other:	Stipend: <input type="checkbox"/> Cellular Telephone \$50/mo <input type="checkbox"/> Data Pad \$25/mo

COUNTY OWNED WIRELESS DEVICE

Office Use / Employee: Office Use Employee ID# _____ Signature: _____

Department: Fire Marshal Dept#: 300

Quantity: 1 950-342-3939

Service: \$ 37.99 /mo (x) 11 months = \$417.89 Account: 61100-421-10-300-001-0-592

Service: \$ _____ /mo (x) _____ months = _____ Account: _____ -619/664

Requisition Total: 7832.30 Requisition Number: 290426

STIPEND

(1) Employee: _____ Employee ID# _____ Signature: _____

Department: _____ Dept#: _____

Quantity: _____

Service: \$ _____ /mo (x) _____ months = _____ Account: _____ -592

Total: _____

(2) Elected Official/Department Head Authorization for Request:

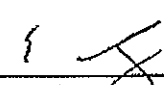
ERIC SANDA
01-11-14

Signature Print Name Date

(3) Executive Office Authorization (Commissioner's Court Departments Only):

Valde Guerra
1/15/16

Signature Print Name Date

(4) IT DEPARTMENT ONLY:

Service Type Codes: 4G Mobile Broadband Int. @ 31.99 mo.

Commissioner's Court Action: _____ Commissioner's Court Date: 2/2/16

Approved Date: _____ Disapproved

Current County cell phone policy stipulates that employees that have cell phones assigned to them will be taxed the value of the service. Please see the following IRS document for more information: <http://www.irs.gov/govt/sg/article/0,,id=187164,00.html>, EXAMPLE 2.

Revised: 03/09/2011



WIRELESS DEVICE REQUEST FORM W.2011.2

TYPE OF REQUEST

County Owned Wireless Device:
 Office Use or Individual
 Name Change
 Equipment Change
 Plan Change
 Delete Service

Wireless Data Device:
 Data Card
 Blackberry
 Other:

Stipend:
 Cellular Telephone \$50/mo
 Data Pad \$25/mo

COUNTY OWNED WIRELESS DEVICE

Office Use / Employee: Office Use Employee ID# _____ Signature: _____

Department: Fire Marshal Dept#: 300

Quantity: 1 950-342-3707

Service: \$ 37.99 /mo (x) 11 months = \$ 417.89 Account: 6-1100-422-10-310-601-0-532

Service: \$ _____ /mo (x) _____ months = _____ Account: _____ -619/664

Requisition Total: 7832.30 Requisition Number: 290424

STIPEND

(1) Employee: _____ Employee ID# _____ Signature: _____

Department: _____ Dept#: _____

Quantity: _____

Service: \$ _____ /mo (x) _____ months = _____ Account: _____ -532

Total: _____

(2) Elected Official/Department Head Authorization for Request:

[Signature] ERIC ANCHER 01.11.16
 Signature Print Name Date

(3) Executive Office Authorization (Commissioner's Court Departments Only):

[Signature] Valde Guerra 1/15/16
 Signature Print Name Date

(4) IT DEPARTMENT ONLY:

Service Type Codes: 4G Mobile Broadband Unl. @ 37.99 mo.

Commissioner's Court Action: _____ Commissioner's Court Date: 2/2/16

Approved Date: _____ Disapproved

Current County cell phone policy stipulates that employees that have cell phones assigned to them will be taxed the value of the service. Please see the following IRS document for more information: <http://www.irs.gov/govt/stg/article/0,,id=167154,00.html>, EXAMPLE 2.



WIRELESS DEVICE REQUEST FORM W.2011.2

TYPE OF REQUEST		
County Owned Wireless Device: <input checked="" type="checkbox"/> Office Use or <input type="checkbox"/> Individual <input checked="" type="checkbox"/> Name Change <input checked="" type="checkbox"/> Equipment Change <input type="checkbox"/> Plan Change <input type="checkbox"/> Delete Service	Wireless Data Device: <input checked="" type="checkbox"/> Data Card <input type="checkbox"/> Blackberry <input type="checkbox"/> Other:	Stipend: <input type="checkbox"/> Cellular Telephone \$50/mo <input type="checkbox"/> Data Pad \$25/mo

COUNTY OWNED WIRELESS DEVICE

Office Use / Employee: Office Use Employee ID#: _____ Signature: _____
 Department: Fire Marshal Dept#: 300
 Quantity: 1 992.342.3675
 Service: \$ 31.99 /mo (x) 11 months = \$417.89 Account: 6-1100-422-10-306-001-0 -532
 Service: \$ _____ /mo (x) _____ months = _____ Account: _____ -619/664
 Requisition Total: 7832.30 Requisition Number: 290426

STIPEND

(1) Employee: _____ Employee ID#: _____ Signature: _____
 Department: _____ Dept#: _____
 Quantity: _____
 Service: \$ _____ /mo (x) _____ months = _____ Account: _____ -532
 Total: _____

(2) Elected Official/Department Head Authorization for Request:

S [Signature] FRANZANO 11-11-16
 Signature Print Name Date

(3) Executive Office Authorization (Commissioner's Court Departments Only):

[Signature] Valde Guerra 1/15/16
 Signature Print Name Date

(4) IT DEPARTMENT ONLY:

Service Type Codes: 4G Mobile Broadband Int. @ 31.99 mo.

Commissioner's Court Action:

Commissioner's Court Date: 2/2/16

Approved Date: _____

Disapproved

Current County cell phone policy stipulates that employees that have cell phones assigned to them will be taxed the value of the service. Please see the following IRS document for more information: <http://www.irs.gov/efile/article/0,,id=167154,00.html>, EXAMPLE 2.

WIRELESS DEVICE REQUEST FORM W.2011.2

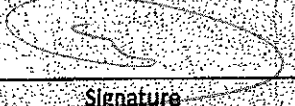
TYPE OF REQUEST		
County Owned Wireless Device: <input type="checkbox"/> Office Use or <input checked="" type="checkbox"/> Individual <input checked="" type="checkbox"/> Name Change <input type="checkbox"/> Equipment Change <input type="checkbox"/> Plan Change <input type="checkbox"/> Delete Service	Wireless Data Device: <input checked="" type="checkbox"/> Data Card <input type="checkbox"/> Blackberry <input type="checkbox"/> Other:	Stipend: <input type="checkbox"/> Cellular Telephone \$50/mo <input type="checkbox"/> Data Pad \$25/mo
COUNTY OWNED WIRELESS DEVICE		
Office Use / Employee: <u>Juan Martinez</u> Employee ID# <u>134126</u> Signature: _____ Department: <u>Fire Marshal</u> Dept#: <u>300</u> No longer employed Quantity: <u>1</u> <u>956-342-3707</u> Service: \$ _____ /mo (x) _____ months = _____ Account: _____ -532 Service: \$ _____ /mo (x) _____ months = _____ Account: _____ -619/664 Requisition Total: _____ Requisition Number: _____		
STIPEND		
(1) Employee: _____ Employee ID# _____ Signature: _____ Department: _____ Dept#: _____ Quantity: _____ Service: \$ _____ /mo (x) _____ months = _____ Account: _____ -532 Total: _____		
(2) Elected Official/Department Head Authorization for Request: <div style="display: flex; justify-content: space-between; align-items: flex-end; margin-top: 10px;"> <div style="text-align: center;">  Signature </div> <div style="text-align: center;"> <u>ERIC ARCHER</u> Print Name </div> <div style="text-align: center;"> <u>01-11-16</u> Date </div> </div>		
(3) Executive Office Authorization (Commissioner's Court Departments Only): <div style="display: flex; justify-content: space-between; align-items: flex-end; margin-top: 10px;"> <div style="text-align: center;">  Signature </div> <div style="text-align: center;"> <u>Valde Guerra</u> Print Name </div> <div style="text-align: center;"> <u>1/15/16</u> Date </div> </div>		
(4) IT DEPARTMENT ONLY: Service Type Codes: <u>Change name to Office Use</u>		

Commissioner's Court Action: _____ Commissioner's Court Date: 2/2/16
 Approved Date: _____ Disapproved

Current County cell phone policy stipulates that employees that have cell phones assigned to them will be taxed the value of the service. Please see the following IRS document for more information: <http://www.irs.gov/govt/irs/article/0,,id=167154,00.html>, EXAMPLE 2.



WIRELESS DEVICE REQUEST FORM W.2011.2

TYPE OF REQUEST

County Owned Wireless Device:
 Office Use or Individual
 Name Change
 Equipment Change
 Plan Change
 Delete Service

Wireless Data Device:
 Data Card
 Blackberry
 Other:

Stipend:
 Cellular Telephone \$50/mo
 Data Pad \$25/mo

COUNTY OWNED WIRELESS DEVICE

Office Use / Employee: Kyle Pullen Employee ID# 203742 Signature: _____
 Department: Fire Marshal Dept#: 300 *No longer with Agency (ES)*
 Quantity: 1 950-342-3675
 Service: \$ _____ /mo (x) _____ months = _____ Account: _____ -532
 Service: \$ _____ /mo (x) _____ months = _____ Account: _____ -619/664
 Requisition Total: _____ Requisition Number: _____

STIPEND

(1) Employee: _____ Employee ID# _____ Signature: _____
 Department: _____ Dept#: _____
 Quantity: _____
 Service: \$ _____ /mo (x) _____ months = _____ Account: _____ -532
 Total: _____

(2) Elected Official/Department Head Authorization for Request:

[Signature] Eric Sanchez 01-11-16
 Signature Print Name Date

(3) Executive Office Authorization (Commissioner's Court Departments Only):

[Signature] Valde Guerra 1/15/16
 Signature Print Name Date

(4) IT DEPARTMENT ONLY:

Service Type Codes: Change name to Office Use

Commissioner's Court Action: _____ Commissioner's Court Date: 2/2/16

Approved Date: _____ Disapproved

Current County cell phone policy stipulates that employees that have cell phones assigned to them will be taxed the value of the service. Please see the following IRS document for more information: <http://www.irs.gov/govt/yslg/article/0,,id=167164,00.html>, EXAMPLE 2.

WIRELESS DEVICE REQUEST FORM W.2011.2

TYPE OF REQUEST		
County Owned Wireless Device: <input type="checkbox"/> Office Use or <input type="checkbox"/> Individual <input checked="" type="checkbox"/> Name Change <input type="checkbox"/> Equipment Change <input type="checkbox"/> Plan Change <input type="checkbox"/> Delete Service	Wireless Data Device: <input type="checkbox"/> Data Card <input type="checkbox"/> Blackberry <input type="checkbox"/> Other:	Stipend: <input type="checkbox"/> Cellular Telephone \$50/mo <input type="checkbox"/> Data Pad \$25/mo

COUNTY OWNED WIRELESS DEVICE VERIZON (956)358-8579

Office Use / Employee: Eli Villegas Employee ID# 185817 Signature: Eli Villegas

Department: Planning Dept. Dept#: 210

Quantity: 1

Service: \$ _____ mo (x) _____ months = \$ _____ Account: _____ -532

Service: \$ 1/mo (x) _____ months = _____ Account: _____ ~~619/664~~

Requisition Total: _____ Requisition Number: _____

STIPEND

(1) Employee: _____ Employee ID# _____ Signature: _____

Department: _____ Dept#: _____

Quantity: _____

Service: \$ _____ /mo (x) _____ months = _____ Account: _____ -532

Total: _____

(2) Elected Official/Department Head Authorization for Request:

X J.J. C T.J. Accadondo 1-14-16

Signature Print Name Date

(3) Executive Office Authorization (Commissioner's Court Departments Only):

[Signature] Valde Guerra 1/15/16

Signature Print Name Date

(4) IT DEPARTMENT ONLY:

Service Type Codes: Transfer to Office Use

Commissioner's Court Action: _____ Commissioner's Court Date: 2/2/14

Approved Date: _____ Disapproved

Current County cell phone policy stipulates that employees that have cell phones assigned to them will be taxed the value of the service. Please see the following IRS document for more information: <http://www.irs.gov/govt/istg/article/0,,id=167164,00.html>, EXAMPLE 2.

Revised: 03/09/2011

WIRELESS DEVICE REQUEST FORM W.2011.2

TYPE OF REQUEST		
County Owned Wireless Device: <input checked="" type="checkbox"/> Office Use or <input type="checkbox"/> Individual <input type="checkbox"/> Name Change <input type="checkbox"/> Equipment Change <input type="checkbox"/> Plan Change <input type="checkbox"/> Delete Service	Wireless Data Device: <input type="checkbox"/> Data Card <input type="checkbox"/> Blackberry <input type="checkbox"/> Other:	Stipend: <input type="checkbox"/> Cellular Telephone \$50/mo <input type="checkbox"/> Data Pad \$25/mo

COUNTY OWNED WIRELESS DEVICE VERIZON (956)358-8579

Office Use / Employee: Office Use Planning Employee ID# N/A Signature: [Signature]

Department: Planning Dept. Dept#: 210

Quantity: 1

Service: \$ /mo (x) months = \$ Account: -532

Service: \$ /mo (x) months = Account: ~~619/664~~

Requisition Total: Requisition Number:

STIPEND

(1) Employee: Employee ID# Signature:

Department: Dept#:

Quantity:

Service: \$ /mo (x) months = Account: -532

Total:

(2) Elected Official/Department Head Authorization for Request:

[Signature] Tomas J. Accredondo 1-12-16

Signature Print Name Date

(3) Executive Office Authorization (Commissioner's Court Departments Only):

[Signature] Valde Guerra 1/15/16

Signature Print Name Date

(4) IT DEPARTMENT ONLY:

Service Type Codes: Assign to Office Use

Commissioner's Court Action: Commissioner's Court Date: 2/2/16

Approved Date: Disapproved

Current County cell phone policy stipulates that employees that have cell phones assigned to them will be taxed the value of the service. Please see the following IRS document for more information: <http://www.irs.gov/govt/istg/article/0,,id=167154,00.html>, EXAMPLE 2.

Requisition

Req # 00290426

PO #

Date: 01/11/16

Bill To: x
x

Vendor : 287024
VERIZON WIRELESS
P.O. BOX 660108
DALLAS TX 75266-0108

Ship To: FIRE MARSHAL
1124 NORTH "M" RD.
EDINBURG TX 78542

Contact: ELIZABETH
956-318-2656

Contract No:

Special Instructions:

QUANTITY	UOM	DESCRIPTION	UNIT PRICE	AMOUNT
		STATE OF TEXAS CONTRACT NO. DIR-SDD-1779		
		DO NOT DUPLICATE ORDER		
11.00	MONTH	AMERICA'S CHOICE II 400 SHARE EMAIL & DATA+N&W+IN UNL \$64.09 0408 (MUST ADD FEATURE CODE 73502) @ \$49.99 EACH LINE FOR THE FOLLOWING: ERIC SANCHEZ 956-289-3873 VICTOR RAMIREZ 956-289-3857 TOMMY URESTE 956-227-7024 JOHN FRANZ 956-393-1848 MEDARDO VILLARREAL 956-929-6675 VACANT POSITION 956-929-6497	299.94	3,299.34
11.00	MONTH	OPEN PO FOR 8 DATA CARDS 4G MOBILE BROADBAND UNLIMITED DATA PLAN @ \$37.99 EACH LINE	303.92	3,343.12
12.00	MONTH	FEES & SURCHARGES (PHONE & TEXT PLAN) @ \$5.00 PER LINE	30.00	360.00
1.00	MONTH	AMERICA'S CHOICE II 1000 SHARE EMAIL & DATA+N&W IN UNL \$96.14 0408 (MUST ADD FEATURE CODE 735502) @ 74.99 EACH LINE FOR THE FOLLOWING: ERIC SANCHEZ 956-289-3873 VICTOR RAMIREZ 956-289-3857 TOMMY URESTE 956-227-7024 JOHN FRANZ 956-393-1848 MEDARDO VILLARREAL 956-929-6675 KYLE PULLEY 956-929-6497 CC APPROVED ON 04-28-2015 49069	449.94	449.94
1.00	MONTH	OPEN PO FOR 10 DATA CARDS 4G MOBILE BROADBAND UNLIMITED DATA PLAN @ \$37.99 EACH LINE CC APPROVED ON 04-28-2015 49069	379.90	379.90

Authorized By: _____

Requisition

Req # 00290426

PO #

Date: 01/11/16

Bill To: x
x

Vendor: 287024
VERIZON WIRELESS
P.O. BOX 660108
DALLAS TX 75266-0108

Ship To: FIRE MARSHAL
1124 NORTH "M" RD.
EDINBURG TX 78542

Contact:

QUANTITY	UOM	DESCRIPTION	UNIT PRICE	AMOUNT
		<u>Account No</u>	<u>Encumbrance</u>	
			Freight	.00
			Total	7,832.30
		REPORT ROAD HAZARDS 1-866-HCR-SAFE OR 1-866-427-7233		

Authorized By: _____

AI-53068

CC - REGULAR

Meeting Date: 01/26/2016

Submitted Sergio Cruz, BUDGET & MANAGEMENT

For:

Submitted By: Merlen P. Munoz, BUDGET & MANAGEMENT

Department: BUDGET & MANAGEMENT

Information

CAPTION

Human Services - 1115 Waiver DSRIP (1100):

Approval to designate the amount of \$764,521.67 in the year 2015 for expenditures related to the 1115 Waiver Program.

BACKGROUND

Fiscal Impact

FISCAL YEAR: 2015 ACCT. #: 5-1100-444-00-240-005-0-XXX

FUNDS AVAILABLE Y/N?: Y MATCHING FUNDS Y/N?: N

BUDGETARY IMPACT:

Funds available as of 1/22/16 (See attached schedule).

Attachments

Funds by Object Code

Form Review

Inbox	Reviewed By	Date
Budget & Management	Veronica Ortiz	01/22/2016 02:14 PM
Purchasing Department	Monica Badillo	01/22/2016 04:11 PM
Form Started By: Merlen P. Munoz		Started On: 01/22/2016 01:37 PM
Final Approval Date: 01/22/2016		

Hidalgo County
Department of Budget and Management

2015 DESIGNATION OF FUNDS
1115 Waiver DSRIP
as of 1/22/16

5-1100-444-00-240-005-0-XXX

Object	Amt to Designate
113	39,810.36
211	5,548.20
212	36.31
220	3,071.37
230	4,216.38
250	241.24
260	83.89
320	41,000.00
336	99,283.86
339	119,810.00
430	10,300.00
520	29.00
583	2,120.80
610	136,411.46
630	823.50
650	5,000.00
660	68,163.20
751	0.00
753	3,843.83
780	716.14
890	223,651.08
Sub-Total:	764,160.62
Adjustment ⁽¹⁾ :	361.05
Grant Total:	<u><u>764,521.67</u></u>

1. Object Codes 211-Health Insurance & 212-Life Insurance pending the reversal of the annual accrual by the Auditor's Office to replenish accounts in the amount of \$359.80 and \$1.25, respectively.

AI-52871

Purchasing Department 12.
A.

CC - REGULAR

Meeting Date: 01/26/2016

Submitted By: Nielda Cavazos, PURCHASING
DEPT.

Department: PURCHASING DEPT.

Information

CAPTION

Acceptance of two (2) rebate checks from:

1. The Local Government Purchasing Cooperative in the amount of \$ 44,963.47
2. Staples in the amount of \$ 25,442.92 for the year 2014-2015 fiscal year.

BACKGROUND

Fiscal Impact

Attachments

staples

The Local Government

receipt 01

receipt

Form Review

Inbox	Reviewed By	Date
Purchasing Department	Darlene Betancourt	01/11/2016 11:27 AM
Budget & Management	Veronica Ortiz	01/12/2016 09:11 AM
Auditor's Office	Monica Badillo	01/22/2016 04:11 PM

Form Started By: Nielda Cavazos Started On: 01/07/2016 11:39 AM
Final Approval Date: 01/22/2016

STAPLES

Vendor: 999992 HIDALGO COUNTY

Check: 5883400 11/19/15

Invoice Number	Inv. Date	Charge Back	Invoice Notes	Invoice Amt	Disc Amt	Pay Amt
CRCREBATE110114103115A	11/12/15			25,442.92		25,442.92

Charge Back Codes: RT1 Mdse. Returned to vendor
 FTR Freight out
 FGT Freight in
 AA2 Unfavorable cost variance

AA7 Carton Shortage

Total: \$25,442.92 0.00 \$25,442.92

STAPLES

500 Staples Dr
 P.O.Box 9368
 Framingham, MA 01702

Bank of America, NA
 Charlotte, NC 28255

Check No. 5883400
 Check Date 11/19/15
 Vendor No. 999992
 Amount

*****\$25,442.92

Twenty five thousand four hundred forty two and 92/100 Dollars

PAY
 To The
 Order Of

HIDALGO COUNTY
 PURCHASING
 2802 SOUTH CLOSNER HIGHWAY 281
 EDINBURG, TX 78539

Christine T Komola
 AUTHORIZED SIGNATURE

⑈05883400⑈ ⑆011201539⑆ 0080 027 747⑈

The Local Government Purchasing Cooperative
 P.O. Box 400
 Austin, Texas 78767-0400
 (800) 695-2919

JPMorgan Chase Bank, N.A., Dallas, TX
 Controlled Disbursement

88-88/1113 00013689

11/30/2015

Vendor No. 108275

FORTY FOUR THOUSAND NINE HUNDRED SIXTY THREE AND 47/100*****

\$****44,963.47

VOID IF NOT CASHED IN 90 DAYS

PAY TO THE ORDER OF HIDALGO COUNTY
 100 E CANO 4TH FLR
 EDINBURGH TX 78539

Judith K. Schroy
James Blair

VOID IF OVER \$44963.47

⑈00013689

⑆111300880⑆

734240047⑈

THE FACE OF THIS CHECK IS BROWN ON WHITE PAPER AND AN ARTIFICIAL WATERMARK APPEARS ON BACK OF CHECK.

The Local Government Purchasing Cooperative
 P.O. Box 400
 Austin, Texas 78767-0400
 (800) 695-2919

Net Amount: \$****44,963.47
 Payee Name: HIDALGO COUNTY

00013689
 11/30/2015

Invoice Number	Invoice Date	Description	Gross	Discount	Amount Paid
113015	11/30/2015	2014-15 COOP BUYBOARD REBA	44,963.47		44,963.47
TOTAL			44,963.47		44,963.47



P.O. Box 400, Austin, Texas 78767-0400
800.695.2919 • Fax: 800.211.5454 • buyboard.com

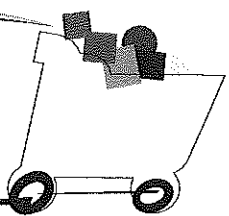

December 4, 2015

RE: Rebate Check

Dear BuyBoard member:

We are pleased to present your organization with the enclosed rebate check.

Because of your participation and confidence in The Local Government Purchasing Cooperative and BuyBoard®, the program has continued to grow over the last few years. The purchasing volume exceeded \$977 million for the 2014-15 fiscal years, and membership has grown to over 4,700 governmental and non-profit members throughout the state.

As a result of the continued growth, the Coop is sending rebate checks to eligible members. The rebate is reflective of the Coop collecting more in vendor service fees than it needed to cover its annual expenditures. As a result, the Cooperative Board approved a distribution of \$5.8 million to be rebated to 981 members, based on each entities contribution to the Cooperative's excess revenue. The enclosed check results from your participation in the Cooperative for the 2014-15 fiscal years.

Our goal is to continue to offer high-quality products at competitive prices from top-performing vendors so that you always find value in the Cooperative and BuyBoard.

Thank you for your participation in the Cooperative, and we look forward to serving you even better in the future.

Sincerely,

Mr. Matthew J. Rivera
Chair
The Local Government Purchasing Cooperative

Endorsed by





OFFICIAL HIDALGO COUNTY RECEIPT
OFFICE OF THE COUNTY TREASURER
NORMA G. GARCIA

Receipt No: 193980

Received From: BUY BOARD COOP. PURCHASING DEPT.

Date 01/07/16

1	00013689	REBATE CHECK	6-1100-115-00-000-000-0-000	44,963.47
---	----------	--------------	-----------------------------	-----------

Total: 44,963.47

Check Total 44,963.47

Cash Total .00

Credit Total .00

Other Total .00



OFFICIAL HIDALGO COUNTY RECEIPT
OFFICE OF THE COUNTY TREASURER
NORMA G. GARCIA

Receipt No: 193981

Received From: STAPLES PURCHASING DEPT.

Date 01/07/16

1 5883400 REBATE CHECK 6-1100-115-00-000-000-0-000 25,442.92

Total: 25,442.92

Check Total 25,442.92
Cash Total .00
Credit Total .00
Other Total .00

AI-52930

Purchasing Department 12.
B. 1.

CC - REGULAR

Meeting Date: 01/26/2016

Submitted Marty Salazar, PURCHASING DEPT.

For:

Submitted By: Heidi Ortiz, PURCHASING DEPT.

Department: PURCHASING DEPT.

Information

CAPTION

Presentation of bids received for the purposes of award and approval of contract document to vendor submitting the lowest and best bid meeting all specifications and/or requirements as attached hereto for: Hidalgo County - "Sign Language Interpreting Services for Courtroom and Non-Courtroom" and subject to HB1295 and all other HC compliance items.

BACKGROUND

1. Current contract expires February 4, 2016
2. New contract to commence February 5, 2016
3. Eight (8) packets requested and distributed - 3 bids submitted
4. Recommended vendor - AllWorld Language Consultants, Inc.

Fiscal Impact

FISCAL YEAR: 2016 ACCT. #: 6-1100-444-00-240-005-0-339

FUNDS AVAILABLE Y/N?: y MATCHING FUNDS Y/N?: n

BUDGETARY IMPACT:

FISCAL YEAR: 2016 ACCT. #: 6-1100-412-00-063-001-0-339

FUNDS AVAILABLE Y/N?: y MATCHING FUNDS Y/N?: n

BUDGETARY IMPACT:

Attachments

Approval by Legal contract

Form Review

Inbox	Reviewed By	Date
Auditor's Office	Monica Badillo	01/22/2016 04:11 PM

Form Started By: Heidi Ortiz
Final Approval Date: 01/22/2016

Started On: 01/13/2016 08:42 AM

Zimbra**heidi.ortiz@co.hidalgo.tx.us**

RE: RFB No. 2016-012-12-16-HGO - "Sign Language Interpreting Services for Hearing Impaired"

From : Steve Crain <scrain@atlashall.com> Fri, Jan 22, 2016 07:32 AM**Subject :** RE: RFB No. 2016-012-12-16-HGO -
"Sign Language Interpreting Services
for Hearing Impaired"**To :** 'Heidi Garcia Ortiz'
<heidi.ortiz@co.hidalgo.tx.us>

The contract is OK subject to the insurance and 1295.

-----Original Message-----

From: Heidi Garcia Ortiz [mailto:heidi.ortiz@co.hidalgo.tx.us]

Sent: Thursday, January 21, 2016 9:58 AM

To: Steve Crain <scrain@atlashall.com>

Subject: RFB No. 2016-012-12-16-HGO - "Sign Language Interpreting Services for Hearing Impaired"

Good morning Mr. Crain:

Attached you will find the final contract and the HB1295 letter for the above listed project. The vendor is currently working on the automobile liability insurance and the HB1295, If the contract is okay as is I will attach it to the agenda item with the notation that approval is subject to current insurance policy and HB1295. Thank you very much for all your help.

Heidi

--

Heidi Garcia Ortiz, Buyer III
Hidalgo County Purchasing Department
2802 S. Business Hwy 281
Edinburg, TX 78539
956-292-7000 Ext. 4877
956-292-7612 Fax

heidi.ortiz@co.hidalgo.tx.us

THE STATE OF TEXAS §
§
COUNTY OF HIDALGO §

SERVICE CONTRACT
C-16-012-01-26

THIS CONTRACT is made and entered into this 26th day of January, 2016 by and between the COUNTY OF HIDALGO, TEXAS ("County"), and AllWorld Language Consultants, Inc. ("Company").

WHEREAS, Company responded to advertised notices for bids for “Sign Language Interpreting Services For Hearing Impaired (Courtroom & Non-Courtroom) (AS NEEDED BASIS)” for Hidalgo County (the "Services"); and

WHEREAS, Company submitted a bid to provide services in accordance with the specifications as bid, a copy of Request for Bid (RFB) Procurement Packet being attached hereto as Exhibit "A" (the “RFB”) and Company’s bid being attached hereto as Exhibit "B" (the “Bid Page”), and incorporated herein for all purposes; and

WHEREAS, in recognition of and in consideration of Company's Contract to perform the Services in accordance with the RFB, the Commissioners’ Court of County awarded the bid to Company.

NOW, THEREFORE, in mutual consideration of the foregoing and further consideration of the following, the parties hereto agree as follows:

1. County and Company hereby agrees that this Contract is entered into in order to provide the Services to locations at Hidalgo County. This Contract does not extend to any third parties any duties or benefits conferred in any manner hereunder or otherwise.

2. Company hereby promises and agrees to render and provide, during the term of this Contract, and shall be obligated to render and provide the Services in accordance with the RFB within **Hidalgo County** following a request for Services by the Department Head, Commissioner, Sheriff or his designated agent. Company agrees in performing the Services that it will use proper professional standards, comply with any and all appropriate laws and regulations in providing the Services, and devote such time as is necessary to safely and efficiently provide the Services.

3. This Contract shall be for a period of one (1) year beginning February 5, 2016 and ending on February 4, 2017 and may be extended at the sole discretion of County for an additional two (2) one (1) year periods, unless this Contract is terminated pursuant to the provisions herein, whichever occurs first. County also reserves the right to continue this bid for an additional sixty (60) day Grace Period, under the same rates, terms and conditions.

4. As a condition of this Contract, Company shall hold and maintain throughout the term of this Contract all licenses and permits required, or which may be required by any authority during the term hereof to provide the Services.

5. All trucks or vehicles operated by the Company to perform the Services shall contain all equipment required by any authority to operate on streets and roads and all persons in the employ of Company who operate such trucks or vehicles shall have the required licenses, qualifications, skill and expertise to perform such Services and shall comply with all laws, rules and regulations prescribed by any agency or authority having jurisdiction with regard to the operation of such trucks or vehicles in providing the Services.

6. As consideration for rendering the Service provided for in this Contract, the County

agrees to pay Company the amounts specified in Exhibit "B" attached hereto payable against written invoice submitted by Company.

7. Company shall provide insurance in force on all its vehicles and all persons connected with providing services under this Contract naming County as an additional insured (with the coverages and in the amounts described on Exhibit "C" attached hereto and incorporated herein at this point for all purposes), and shall furnish to County certificates of such insurance coverage.

8. Company shall provide a sufficient number of trucks, vehicles, personnel and equipment available to safely and efficiently provide the Services.

9. Company shall indemnify and hold harmless County, its elected officials, employees and agents from any and all claims, damages, losses, and expenses including attorney's fees for the defense of any action against County arising out of, resulting from, or connected with the provision of the Service by Company under this Contract. Said indemnity shall cover any act or failure to act by the Company, its agents or employees.

10. This Contract shall not be assignable in whole or in part by either party without prior written consent of the other party.

11. It is expressly agreed that this Contract and the performance by the parties hereunder does not create any agency relationship or master-servant relationship, which County has no supervision of the performance of the Services provided by Company, and that Company is an independent contractor under this Contract.

12. Any notice required or permitted to be given hereunder shall be in writing and shall be delivered personally or sent by certified mail, postage prepaid, as set forth below:

If to County: **The County of Hidalgo**
 Attn: County Judge
 100 E. Cano
 Edinburg, Texas 78539

If to Company **AllWorld Language Consultants, Inc.**
 172 Rollins Avenue, Suite 3 & 3A
 Rockville, MD 20852-4005

13. In case any one or more of the provisions contained in this Contract shall for any reason be held to be invalid, illegal or unenforceable in any respect, such invalidity, illegality, or unenforceability shall not affect any other provision thereof and this Contract shall be construed as if such invalid, illegal, or unenforceable provision had never been contained herein.

14. This Contract may be terminated by County without cause upon thirty (30) days written notice.

15. This Contract shall be binding upon and inure to the benefit of and be enforceable by the parties hereto and their respective heirs, executors, administrators, legal representatives, successors, and assigns where permitted by this Contract.

16. This Contract shall be governed by and construed in accordance with the laws of the State of Texas and shall be performable in Hidalgo County.

17. **Commitment of Current Revenues Only.** In the event that, during any term hereof, the Commissioners Court does not appropriate sufficient funds to meet the obligations of County under this Contract, County may terminate this Contract upon ninety (90) days written notice to Company. County agrees, however, to use reasonable efforts to secure funds necessary for the continued performance of this Contract. The parties intend this provision to be a continuing right to terminate this Contract at the expiration of each budget period of County pursuant to the

provisions of Tex. Loc. Govt. Code Ann. ' 271.903 (Vernon Supp. 1996).

18. **Entire Agreement.** This Contract contains the entire contract between the parties hereto, and each party acknowledges that neither has made (either directly or through any agent or representative) any representations or agreements in connection with this Contract not specifically set forth herein. This Contract may be modified or amended only by agreement in writing executed by County and Company, and not otherwise.

19. **Immunities.** Nothing in this Contract is intended to and County does not hereby waive, release or relinquish any right to assert any of the defenses County enjoys by virtue of the state or federal constitution, laws, rules or regulations, and any sovereign, official or qualified immunity available to County as to any claim or action of any person, entity, or individual against County.

WITNESS our hands in duplicate originals this _____ day of _____, 2016.

COUNTY OF HIDALGO

ATTEST:

By: _____
Ramon Garcia, County Judge

Arturo Guajardo Jr., County Clerk

COMPANY:

By: _____
Printed Name: _____
Title: _____

APPROVED AS TO FORM:
Atlas & Hall, L.L.P.

By: Steve L. Crain

EXHIBIT “A”

REQUEST FOR BID
(RFB)
PROCUREMENT
PACKET



Hidalgo County Purchasing Department
2812 S. Business Highway 281
Edinburg, Texas 78539
(956) 318-2626/ Fax: (956) 318-2629

REQUEST FOR BIDS (RFB)

Hidalgo County
***“Sign Language Interpreting Services for Hearing Impaired
(Courtroom and Non-Courtroom)***
Bid No.:2016-012-12-16-HGO

Table of Contents

Item	Description	No. of Pages
1.	Request for Bid Letter	1
2.	Request for Bid, Legal Notice	8
3.	Exhibit “A” Specifications/Requirements	4
4.	Exhibit “B” Bid Page,	2
5.	Exhibit “C” Insurance Requirements	4
6.	Exhibit “D” CIQ Conflict of Interest Questionnaire	1
7.	Vendor/Bidder Application and W-9 form	6
8.	Certification Regarding Debarment	1
9.	Draft Service Contract	8

The above mentioned items shall be found in the Request for Bid (RFB) packet that is attached herewith. Should you find that any of the items are not attached in its entirety please contact Purchasing by calling (956) 318-2626 or via email to heidi.ortiz@co.hidalgo.tx.us, and advise of missing documentation.

Thank you.

Martha L. Salazar, CPPB, Purchasing Agent

November 30, 2015

Date



Hidalgo County Purchasing Department
2812 S. Business Highway 281
Edinburg, Texas 78539
(956) 318-2626/ Fax: (956) 318-2629

November 30, 2015

Bidder's name

Address

City

State, Zip Code

Re: **HIDALGO COUNTY**

Request for Bids-*"Sign Language Interpreting Services for Hearing Impaired-(Courtroom and Non-Courtroom)"*

Bid No: 2016-012-12-16-HGO

Dear Prospective Bidders:

Enclosed please find a Request for Bid (RFB) packet for your review and consideration.

Hidalgo County Purchasing Department welcomes and appreciates your participation in the bid process.

If any further assistance is required, please do not hesitate to call the Purchasing Department 956/318-2626.

Sincerely,

Martha L. Salazar, CPPB
Hidalgo County Purchasing Agent

MLS/hgo
Enclosures

Bid No: 2016-012-12-16-HGO

Buyer: Heidi Garcia Ortiz

Tel. No: (956) 318-2626 Ext. 4877

REQUEST FOR BIDS

HIDALGO COUNTY
(All Funding Sources, Programs and Entities)

***“Sign Language Interpreting Services for Hearing Impaired-
(Courtroom and Non-Courtroom)***

Bid No.:2016-012-12-16-HGO

BID OPENING DATE: December 16, 2015 @ 9:30 a.m.

Contact Person:

Martha L. Salazar, CPPB, Purchasing Agent
Hidalgo County Purchasing Department
Physical Address: 2802 S. Business Hwy. 281 -New Administration Building
Mailing/Postal Address: 2812 S. Business Hwy. 281
Edinburg, Texas 78539

956 318-2626



1. Sealed bids will be received for "Hidalgo County Sign Language Interpreting Services for Hearing Impaired (Courtroom and Non-Courtroom)" in accordance with the specifications attached as Exhibit "A" hereto. Bids should address all specifications set forth. Bidders may suggest substitutions of features which they feel would be in the best interest of Hidalgo County ("County"). Strong rationale must be presented for any deviation from the specifications. Hidalgo County reserves the right to reject the deviation and its effect on the overall bid.
2. **One (1) original and Three (3) copies** of all bids are required with the bidders name and return address clearly typed/printed on upper left hand corner and the proper notation clearly typed/printed on the lower left hand corner of the envelope and/or package: Bid-2016-012-12-16-HGO-"Hidalgo County Sign Language Interpreting Services for Hearing Impaired (Courtroom and Non-Courtroom)" and in County's Purchasing Department with a physical address: 2802 S. Business 281 and a mailing address: 2812 S. Business Hwy., 281, New Administration Building, Edinburg, Texas, on or before 9:30 A.M., Wednesday, December 16, 2015.

NO FACSIMILES OR LATE ARRIVALS WILL BE ACCEPTED. ANY BID RECEIVED AFTER THAT TIME WILL NOT BE OPENED AND WILL BE RETURNED. OVERNIGHT MAIL MUST ALSO BE PROPERLY LABELED ON THE OUTSIDE OF EXPRESS ENVELOPE OR PACKAGE IN REFERENCE TO RFB No.2016-012-12-16-HGO-"Hidalgo County Sign Language Interpreting Services for Hearing Impaired (Courtroom and Non-Courtroom)"

Hidalgo County reserves the right to refuse and reject any/all bids and to waive any/all formalities or technicalities, or to accept the bid considered the best and most advantageous to Hidalgo County.

3. Hidalgo County reserves the right to: A. separate and accept, or eliminate any item(s) listed under this bid that it deems necessary to accommodate budgetary and/or operational requirements; B. reject any or all bids submitted and further reserves the right to design the evaluation criteria to be used in selecting the lowest and best bid for approval; and C. award the bid to one bidder or to multiple bidders if the County determines it is in its best interest to do so."
4. The Bidder shall not substitute items named in the bid without the express written consent of Hidalgo County. Failure of the delivered item(s) to perform as specified or failure to meet the stated delivery schedule shall release Hidalgo County from all obligations to the contracting party with regard to the item(s) in question. In such event, County may elect to award the contract to the next-lowest responsible bidder, or to reject all bids and re-advertise.
5. For work to be performed at a County owned or operated location, each bidder shall, in its sole discretion, visit the job site before preparing the bid and thoroughly familiarize himself/herself with existing conditions. Bidder should take field dimensions and note all circumstances which affect the dollar amount of the bid.

6. Descriptive specifications are referenced in this document to indicate the general kind and quality of equipment desired by Hidalgo County. Due to various styles and models of equipment, bidders are required to include illustrations, specifications, explanation of warranties, and service data with their bid including catalogue numbers and any necessary references.
7. No bid may be withdrawn within thirty (30) days from the scheduled time to open bids.
8. Proposed prices are to remain firm for a minimum of ninety (90) days after bid opening.
9. Any interpretations, amendments, corrections or changes to this bid document must be in a written addendum and signed by the County Judge or his designee. Addenda will be mailed to all who are known to have received a copy of the Request for Bids. Bidders shall acknowledge receipt of all addenda as a part of their bid.
10. County reserves the right to accept or reject any or all bids.
11. Costs are to be net F.O.B., County Prepaid.
12. County is exempt from Federal Excise Tax, State Tax and Local Tax. DO NOT include tax in cost figure. If it is determined that tax was included in the cost figures it will not be included in the tabulation of any awards. Tax exemption certificates will be furnished upon request.
13. Funds for this procurement have been provided through the County budget for this fiscal year only. County, on an annual basis, has the right to reconsider a contract during the budget process for ensuing years if financial resources of County are insufficient to meet the liabilities of said contract. The award of a bid or contract hereunder will not be construed to create a debt of the County which is payable out of funds beyond the current fiscal year.
14. Upon award and prior to execution of a contract, Sole Proprietorships are required to submit a copy of their social security cards to the Hidalgo County Auditor's Office in order to establish an account with the County. All awarded vendors must submit a completed W-9 and a copy of their Federal ID Number Certificate.
15. **DELIVERY INSTRUCTIONS:**
 - No deliveries accepted after 3:00 P.M., Monday-Friday.
 - At least seventy two (72) hours prior notice of delivery must be given to Martha L. Salazar, Purchasing Agent before delivery will be accepted.
 - If you need additional information call the office listed below:

Hidalgo County Purchasing Department
Martha L. Salazar, Purchasing Agent
(956) 318-2626

15. BILLING AND PAYMENT INSTRUCTIONS:

- Invoices must include:
 - a) Name and address of successful bidder
 - b) Name and address of receiving department or official
 - c) Purchase Order Number and Contract Number (if any)
 - d) Notation – “Hidalgo County Sign Language Interpreting Services for Hearing Impaired (Courtroom and Non-Courtroom)” Descriptive information as to the items or services delivered, including product code, item number, quantity, etc.

- Discount payments will be considered when offered.

- Contact person for Billing and Payment questions:

Elizabeth Cano, Accounts Payable Supervisor
 Hidalgo County Auditor’s Office
 2808 S. Business Hwy 281
 Edinburg, Tx 78539
 (956) 318-2511

17. SCHEDULE OF EVENTS

Bid Opening, 9:30 AM	<u>December 16, 2015</u>
Award of Contract	_____, 2015
Commence Work or Deliver Products	_____, 2015

18. ~~Bid or Performance Bond and DEBARMENT CERTIFICATION; Payment under Contract(if applicable)~~

- If the contract proposed is for the construction of public works or is for a contract for goods & services exceeding \$100,000, all bidders shall furnish a good and sufficient bid bond in the amount of five percent of the total contract price. A bid bond must be executed with a surety company authorized to do business in Texas. All bidders are also required to furnish a certification or acknowledgment stating that the contractor or vendor is free from suspension or debarment pursuant to federal regulation 45CFR Part 76.

- Together with the signing of a contract or issuance of a purchase order following the acceptance of a bid, and prior to commencement of the actual work, the bidder shall furnish a performance bond to the County for the full amount of the contract, if that contract exceeds \$50,000.

- If the contract is for \$50,000 or less, no money will be paid to the contractor until completion and acceptance of the work or the fulfillment of the purchase obligation to the County, and, if applicable, the receipt by County of satisfactory evidence that all

subcontractors and material men have been paid.

- If a contract is for the construction, alteration or repair of public buildings or public works, the contractor *shall* provide a payment bond for a contract in excess of Twenty Five Thousand Dollars (\$25,000.00), as required by Tex. Govt. Code Ch. 2253.
- For requirements contracts, bond requirements are determined by applying the proposed unit price to the estimated quantities included in the specifications.

19. **ETHICAL STANDARDS:**

- It shall be a breach of ethics to offer, give or agree to give any elected official, department head or employee, or former elected official, department head or employee, of the County, or for any elected official, department head or employee or former elected official, department head or employee of the County, to solicit, demand, accept or agree to accept from another person, entity or organization, a gratuity or an offer of employment in connection with any decision, approval, disapproval, recommendation, preparation or any part of a program requirement or purchase request, influencing the content of any specification or procurement standard, rendering of advice, investigation, auditing, or in any other advisory capacity in any proceeding or application, request for ruling, determination, claim or controversy, or other particular matter pertaining to any program requirement or a contract or subcontract, or to any solicitation or proposal therefore pending before any department or agency of the County.
- It shall be a breach of ethics for any payment, gratuity or offer of employment to be made by or on behalf of a subcontractor under a contract to the prime contractor or higher tier subcontractor for any contract for the County, or any person associated therewith, as an inducement for the award of a subcontract or order.
- No public official shall have an interest in a contract awarded hereunder except in accordance with Tex. Loc. Govt. Code Chapter 171.

20. **DISCLOSURE OF CONFLICT OF INTEREST**

- Effective January 1, 2006, Chapter 176 of the Texas Local Government Code requires that any vendor, person, consultant or contractor considering doing business with Hidalgo County ("the County") to disclose in the Conflict of Interest Questionnaire (the "CIQ") attached as Exhibit D, the vendor, person, consultant or contractor's affiliation or business relationship that might cause a conflict of interest with the County. By law, the CIQ must be filed with the Hidalgo County Clerk's Office no later than the seventh business day after the date the person becomes aware of facts that require that statement to be filed. The disclosure requirement applies to a person or business that contracts or seeks to contract with Hidalgo County for the sale or purchase of property, goods or service. Any purchase order or contract resulting

from this process shall be considered null and void if the successful bidder fails to comply with Texas Local Government Code Chapter 176. Vendors, consultants, contractors and others who desire to conduct business with Hidalgo County are encouraged to refer to Texas Local Government Code Chapter 176 for the details of this law. An offense under Texas Local Government Code Chapter 176 is a Class C Misdemeanor.

Please Submit completed CIQ forms to the Hidalgo County Clerk's Office located at 100 N. Closner, Edinburg, Texas 78539-Hidalgo County Courthouse COMPLETION AND SUBMISSION OF FORM CIQ IS THE SOLE RESPONSIBILITY OF THE PROSPECTIVE BIDDER.

21. If, during the life of any contract or bid awarded, the successful bidder's net prices generally available to other customers for items awarded herein are reduced below the contracted price, it is understood and agreed that the benefits of such reduction shall be extended to County.
22. Bids, and all goods and services provided there under, shall comply with all federal, state and local laws concerning this type(s) of goods and/or services.
23. Minimum Standards For Responsible Prospective Bidders: A prospective bidder must affirmatively demonstrate bidder's responsibility. A prospective bidder, by submitting a bid, represents to County that it meets the following requirements:
 - Possess or is able to obtain adequate financial resources as required to perform under the bid;
 - Be able to comply with the required or proposed delivery schedule;
 - Have a satisfactory record of performance;
 - Have a satisfactory record of integrity and ethics;
 - Be otherwise qualified and eligible to receive an award.
24. Successful bidder will pay or cause to be paid, without cost or expenses to County, all FICA, FUTA/SUTA and Federal Income Withholding Taxes of all employees, and all wages and benefits as required by Federal or State law. Successful bidder's officers, agents and/or employees will not be entitled to any benefits of an employee or elected official of County, including, but not limited to, benefits associated with County's civil service system.
24. Any contract award to a successful bidder will be in effect until (a) the contract expires, (b) delivery and acceptance of products, and/or performance of services ordered, or (c) terminated by County with thirty day's written notice prior to cancellation.
25. County reserves the right to enforce performance of any contract awarded hereunder in any manner prescribed by law or deemed to be in the best interest of the County in the event of breach or default by successful bidder. County reserves the right to terminate

any contract immediately in the event a successful bidder fails to:

- A. Meet schedules;
 - B. Pay any required fees or taxes; or
 - C. Otherwise perform in accordance with the specifications.
26. Successful bidder shall defend, indemnify and save harmless County and all its elected officials, officers, agents and employees from all suits, actions, or other claims of any character, name and description brought for or on account of any injuries or damages received or sustained by any person, persons, or property on account of any negligent act or fault of the successful bidder, or of any agent, employee, subcontractor or supplier of successful bidder in the execution of, or performance under, any contract which may result from bid award or which arises from any event or casualty happening on or within County premises themselves or happening upon or in any halls, elevators, entrances, stairways or approaches of or to such County facilities. Successful bidder shall pay any judgment with costs which may be obtained against County growing out of such injury or damages, and shall, upon request, provide a defense to County by counsel reasonably acceptable to County. Successful bidder's indemnity hereunder shall include, but is not limited to, claims relating to patent, copyright or trademark infringement, and the like, arising out of the goods and services provided by successful bidder.
27. Successful bidder shall warrant that all items/services shall conform to the specifications and/or all warranties provided under the Uniform Commercial Code and be free from all defects in material, workmanship and the like. Items supplied under a contract pursuant to this Request for Bids shall be subject to County's approval. Items found to be defective or not meeting specifications shall be replaced by successful bidder within two business days at no expense to County. Items not picked up within one (1) week after notification shall be deemed a donation to County and may be used or disposed of at County's discretion and without waiver of any other rights of County as to the item's nonconformity.
28. This document and any disputes arising hereunder shall be governed and construed according to the laws of the State of Texas, and will be performable exclusively in Hidalgo County, Texas.
29. The successful bidder shall not assign, sell, transfer or convey its rights under any awarded contract, in whole or in part, without the prior written consent of County.

Bid

For

Hidalgo County

“Sign Language Interpreting Services for Hearing Impaired (Courtroom and Non-Courtroom)”

To: Martha L. Salazar, CPPB, Purchasing Agent
Hidalgo County Purchasing Department
Physical address: 2802 S. Business Hwy. 281-New Administration Building
Mailing address: 2812 S. Business Hwy. 281
Edinburg, Texas 78539

In accordance with the Specifications, and subject to all laws and regulations of the United States and state and local laws, the undersigned bidder proposes and commits to furnish all labor, equipment, material, software and services as set forth in the documents hereinbefore mentioned. The undersigned bidder further agrees, upon acceptance of its bid, to execute a contract and/or Purchase Order issued by Hidalgo County for performing and completing the work described in the Specifications within the time stated and for the prices proposed in the documents attached hereto and made a part hereof.

Bidder acknowledges receipt of all of the pages of the documents referenced in the Invitation to Bid Checklist presented in connection with this procurement. Bidder understands that Hidalgo County reserves the right to reject any or all bids and further reserves the right to design the evaluation criteria to be used in selecting the lowest and best bid.

Bidder agrees that this bid shall be good and may not be withdrawn for a period of ninety (90) calendar days after the scheduled closing time for receiving bids, as contained in the Specifications.

Respectfully submitted,

Bidder: _____
Address: _____
By: _____
Printed Name: _____
Title: _____

EXHIBIT "A"
SPECIFICATIONS/REQUIREMENTS
HIDALGO COUNTY

"Sign Language Interpreting Services for Hearing Impaired-(Courtroom and Non-Courtroom)"
Bid No.:2016-012-12-16-HGO

SCOPE OF SERVICES

The intent of this solicitation is to acquire the services of a sign language interpreting firm (Vendor) for all County agencies on an as-needed and emergency basis.

More than one award may be made under this solicitation to assure complete coverage for the County's needs throughout the contract term.

SPECIFICATIONS/REQUIREMENTS:

1. Vendor shall maintain a staff of certified interpreters and qualified (non-certified) interpreters who will be able to respond to emergency needs 24 hours each day with a 2-hour response time.
2. Vendor must maintain such records as may be required by the specialized needs of the various County departments requiring the services.
3. Vendor shall provide certified interpreting services and qualified (non-certified) interpreting services to the County relating to matters, including but not limited to:
 - a) Court related
 - b) Law enforcement related matters
 - c) Health and mental health clinic visits
 - d) Social services needs
 - e) Engineering/technical meetings/workshops
 - f) Staff meetings
 - g) Public meetings
 - h) Probation Related Matters
4. Vendor must work closely with County personnel to ensure full participation by all hearing impaired persons in the relationship with the County.
5. Vendor must maintain adequate interpreting resources to cover all assignments made with advance notice. Vendor must provide the County with all data about their interpreting pool including number of interpreter's available (certified and non-certified), number of certified interpreters with legal specialization, and the names of the primary people and their certification level, who will be providing services under this contract.
6. Vendor must guarantee that each interpreter assigned is qualified to provide the highest quality of communication for the situation and for the individual(s) being served.
7. Vendor must maintain a detailed record regarding each assignment placed against the contract.
8. Vendor shall ask for a purchase order number for the services rendered that will be requested by authorized County personnel.

9. If vendor fails to honor the promised assignment date for any reason, it will result in the provision of a like period of services for the County at no charge.
10. After bid is awarded and low bidders default in meeting the general instructions to bidders and/or comply with contract agreement, Hidalgo County reserves the right to seek services from the next low bidder. In such event, County shall charge the successful bidder the difference for any additional cost of such item.
11. If Vendor fails to honor scheduled assignments this may result in contract termination.
12. If in any event, a department requires more than two hours of interpreting services, Vendor must provide a second interpreter as a back up and relief.
13. Vendor shall be on a cost per hour for interpreting services from the time that the interpreter arrives at the location or the time of the appointment previously scheduled until completion of the service. No travel or portal to portal rates will be accepted by the County. Pricing for on-site interpreting services shall be based on the schedule in the bid page (Exhibit B) form enclosed. No more than one interpreter shall be sent in response to a service request unless the use of additional interpreters is pre-approved and ordered by the requesting department.
14. Due to unforeseen circumstances, it may be necessary to reschedule appointment times. The County will endeavor to provide as much notice as possible for all cancellations. If notice of cancellation is not received by Vendor within 24 hours County will allow a minimal fee to be charged. Vendor must indicate cancellation fee on Bid Page.

INTERPRETING SERVICES:

Business Service Requests:

It is understood and agreed that there are 2 categories for Business hour request, this includes Business Hour Requests with at least 24 hour notice, and Business Hour requests with 2 to 23 hours and 59 minutes in advance. It is understood and agreed that the County will pay the higher business hour rate when notice is given 2 to 23 hours and 59 minutes in advance.

Extended Service Requests:

An extended service hour is any scheduled interpreting situation which begins after 6:00 p.m. and before 8:00 a.m., Monday through Friday and Weekends. Weekend interpreting services is any scheduled interpreting situation which occurs anytime on Saturday or Sunday.

Emergency/Holidays:

- 1) When an emergency situation arises, the department staff or designated representative will call the Vendors' emergency telephone number, and request the emergency services of a certified on-call interpreter.
- 2) The Vendor must be able to provide interpreters within two (2) hours of receiving request for emergency services.
- 3) Emergency interpreting service situations within proceedings of state agencies, courts, and political subdivisions are defined as essential situations which are potentially life threatening or pose a threat to the clients' well-being during any time of the day or night.

- 4) Holiday Interpreting service situations are defined as applying to any Federal, or County observed holiday.

When making requests (phone, e-mail or fax) authorized County personnel will provide the following information:

- Date, time and expected duration of the assignment.
- Location (street address, room number) of the assignment.
- Name and phone number of an on-site contact person.
- Special information pertinent to the appropriate placement of an interpreter (type of meeting, communication preference of the client).
- Name of deaf or hard of hearing client(s) when possible.
- Number of interpreters required.

STAFFING/INTERPRETERS AVAILABLE

The Vendor shall provide with its bid response:

- a) Type(s) of certification held by the interpreters
- b) Number of CERTIFIED interpreters available
- c) Number of NON-CERTIFIED interpreters available
- d) The extent of training and evaluation of interpreters provided by the Vendor
- e) Names of primary certified interpreters who will be providing the services
- f) Names of primary non-certified interpreters who will be providing the services
- g) A discussion on the Vendor's quality control program and how vendor will work with the County's Representative on procedures and/or reviews of interpreting program.

REFERENCES:

Provide references where similar services have been provided by the firm.

BID PRICES:

Prices shall remain firm for the period of the contract. Bidder must include any and all cost in the hourly rate price entered in Exhibit "B" Bid Page.

TERM OF CONTRACT:

- a) The Contract unit prices will remain firm for an initial one (1) year with Hidalgo County's sole discretion to extend the contract for an additional two (2) one year terms under the same rates, terms and conditions.
- b) Hidalgo County reserves the right to continue this bid for an additional sixty (60) day grace period at the end of the contract term for unforeseen delay in award of new bid for new contract term.
- c) If, during the life of the contract, the successful bidder prices generally available for items awarded are reduced or below the contract price, it is understood and agreed that the benefits of such reduction be extended to the County.

METHOD OF AWARD:

Award, if any, will be made to the responsible bidder(s) submitting the lowest bid prices for the

items(s) as specified in Exhibit "B"(Bid Page) and meeting all the requirements/and or specifications.

PAYMENT PROCEDURES

The Vendor will prepare an itemized invoice with attached documentation for each service rendered including the purchase order number, date and time of service. Emergency calls under this network will be included on the itemized invoices submitted to the County Department.

QUALIFICATIONS

The Vendor must have the following qualifications but not limited to the following:

- a) Be regularly engaged in the sign language interpreting business.
- b) Have available under direct supervision and employment, the necessary organization and facilities to properly fulfill the services required in a timely manner.
- c) Have available certified interpreters with a minimum of two (2) years experience in sign language interpretation for the hearing impaired.
- d) Have available non-certified interpreters with a minimum of five (5) years experience in sign language interpretation for the hearing impaired.
- e) Provide certified interpreters and non-certified interpreters to perform sign language interpretation fluently. Hidalgo County reserves the option to request replacement interpreter(s) after the service period has begun if necessary; and at any other time deemed necessary.

ADDITIONAL INFORMATION:

- 1) All costs and expenses associated with the preparation and submission of all (bids, proposals, statements of qualifications (RFQ) and quotes) shall be the responsibility of the vendor and no reimbursements for such charges or expenses shall be passed on to Hidalgo County.
- 2) Hidalgo County is requesting that any and all questions, inquires and clarifications regarding quotes, bids, proposals or statements of qualifications be addressed to Martha L. Salazar, CPPB, Purchasing Agent, Attn: Heidi Garcia Ortiz, 2812 South Business Hwy. 281, Edinburg, Tx 78539. TELEPHONE INQUIRIES WILL NOT BE ACCEPTED.
- 3) ALL WRITTEN INQUIRIES WILL BE ACCEPTED VIA FACSIMILE to (956) 292-7612 and/or e-mail to heidi.ortiz@co.hidalgo.tx.us by no later than **Wednesday, December 9, 2015 by 5:00 p.m.** Responses to said inquiries will be sent to all applicants via facsimile by no later than **Friday, December 11, 2015 by 5:00 p.m.**

EXHIBIT "B"

Bid Page
HIDALGO COUNTY

"Sign Language Interpreting Services for Hearing Impaired-(Courtroom and Non-Courtroom)"

Bid No.:2016-012-12-16-HGO

NIGP Commodity Code: 961-75 Sign Language Services for Hearing Impaired

Prices shall include all costs associated with the provision of all services, including administrative fees, if any, and local travel related costs.

<u>HOURS OF SERVICE</u>	<u>NON-COURTROOM</u> Interpreting Assignments	<u>COURTROOM</u> Interpreting Assignments
BUSINESS HOURLY RATES – CERTIFIED INTERPRETER (Scheduled at least 24 hours in Advance) Monday through Friday (8:00 a.m-6:00 p.m.)	\$	\$
BUSINESS HOURLY RATES – CERTIFIED INTERPRETER (Scheduled less than 24 hours in advance) Monday through Friday (8:00 a.m-6:00 p.m.)	\$	\$
BUSINESS HOURLY RATES – NON-CERTIFIED INTERPRETER (Scheduled at least 24 hours in Advance) Monday through Friday (8:00 a.m-6:00 p.m.)	\$	\$
BUSINESS HOURLY RATES – NON-CERTIFIED INTERPRETER (Scheduled less than 24 hours in advance) Monday through Friday (8:00 a.m-6:00 p.m.)	\$	\$
EXTENDED SERVICE HOURLY RATES – CERTIFIED INTERPRETER (Between 6:00 p.m. and 8:00 a.m.) Monday through Friday and Weekends	\$	\$
EXTENDED SERVICE HOURLY RATES – NON-CERTIFIED INTERPRETER (Between 6:00 p.m. and 8:00 a.m.) Monday through Friday and Weekends	\$	\$
EMERGENCY/ HOLIDAYS – CERTIFIED INTERPRETERS (as defined by the Texas Commission for the Deaf and Hard of Hearing) Emergency interpreting service situations which are potentially life threatening or pose a threat to the clients' well-being during any time of the day or night. Holiday interpreting service situations apply to any Federal or County observed holiday.	\$	\$
EMERGENCY/ HOLIDAYS – NON-CERTIFIED INTERPRETERS (as defined by the Texas Commission for the Deaf and Hard of Hearing) Emergency interpreting service situations which are potentially life threatening or pose a threat to the clients' well-being during any time of the day or night. Holiday interpreting service situations apply to any Federal or County observed holiday.	\$	\$
LESS THAN 24 HOUR CANCELLATION FEE CERTIFIED INTERPRETER	\$	\$
LESS THAN 24 HOUR CANCELLATION FEE NON-CERTIFIED INTERPRETER	\$	\$

BIDDER'S INFORMATION:

I/We the undersigned hereby certify that I/We am/are a duly authorized official of the company and have the authority to sign on behalf of the company and assure that all statements made in the bid are true. I/We agree to furnish and deliver the specified items/services at the prices stated herein, and have read, understand, and agree to the terms and conditions contained herein and on all of the attachments.

BIDDER/COMPANY NAME:

ADDRESS:

CITY/STATE/ZIP CODE:

PHONE & FAX NO'S:

CELLULAR NO:

E-MAIL ADDRESS:

AUTHORIZED SIGNATURE:

PRINTED NAME:

TITLE

EXHIBIT "C"
Insurance Requirements
Applicable to the Acquisition of Goods and /or Services
(other than Professional Services)

The Bidder awarded the contract shall furnish proof of insurance, which will also include any subcontractor that is subcontracted by the bidder in at least the following limits, to be in place prior to providing any services under this Contract and to continue at all times in force in effect during the term of this Contract:

1. A Five Hundred Thousand Dollar (\$500,000.00) Comprehensive General Liability insurance policy providing additional coverage to all underlying liabilities of County.
2. Automobile liability insurance policy with limits of at least Three Hundred Thousand Dollars (\$300,000.00) per person and Five Hundred Thousand Dollars (\$500,000.00) per occurrence. Coverage should include injury to or death of persons and property damage claims with limits up to Five Hundred Thousand (\$500,000.00) arising out of the services provided to County hereunder.
3. Uninsured/Underinsured motorist coverage in an amount equal to the bodily injury limits set forth immediately above;
4. Workers compensation insurance in amounts established by Texas law, unless the Bidder is specifically exempted from the Texas Workers Compensation Act, Texas Labor Code Chapter 401, et. seq.

Hidalgo County will only accept certificates of insurance on an Acord form (as attached hereto). Certificates of insurance shall name Hidalgo County as additional insured and must be submitted to County for approval prior to any services being performed by Contractor. Each policy of insurance required hereunder shall extend for a period equivalent to, or longer than the term of the Contract, and any insurer hereunder shall be required to give at least thirty (30) days written notice to the County prior to the cancellation of any such coverage on the termination date, or otherwise. This Contract shall be automatically suspended upon the cancellation, or other termination, of any required policy of insurance hereunder, and such suspension shall continue until evidence adequate replacement coverage is provided to County. If replacement coverage is not provided within thirty (30) days following suspension of the Contract, this Contract shall automatically terminate.

Revised 10/01/08

ACORD		CERTIFICATE OF INSURANCE	DATE (MM/DD/YY)
PRODUCER	THIS CERTIFICATE IS ISSUED AS A MATTER OF INFORMATION ONLY AND CONFERS NO RIGHTS UPON THE CERTIFICATE HOLDER. THIS CERTIFICATE DOES NOT AMEND, EXTEND OR ALTER THE COVERAGE AFFORDED BY THE POLICIES BELOW.		
INSURERS AFFORDING COVERAGE			
INSURED	INSURER A:		
	INSURER B:		
	INSURER C:		
	INSURER D:		
	INSURER E:		

COVERAGES

THE POLICIES OF INSURANCE LISTED BELOW HAVE BEEN ISSUED TO THE INSURED NAMED ABOVE FOR THE POLICY PERIOD INDICATED. NOTWITHSTANDING ANY REQUIREMENT, TERM OR CONDITION OF ANY CONTRACT OR OTHER DOCUMENT WITH RESPECT TO WHICH THIS CERTIFICATE MAY BE ISSUED OR MAY PERTAIN, THE INSURANCE AFFORDED BY THE POLICIES DESCRIBED HEREIN IS SUBJECT TO ALL THEIR TERMS, EXCLUSIONS AND CONDITIONS OF SUCH POLICIES. AGGREGATE LIMITS SHOWN MAY HAVE BEEN REDUCED BY PAID CLAIMS.

INSR LTR	TYPE OF INSURANCE	POLICY NUMBER	POLICY EFFECTIVE DATE (MM/DD/YY)	POLICY EXPIRATION DATE (MM/DD/YY)	LIMITS
A	GENERAL LIABILITY				EACH OCCURRENCE \$
	<input type="checkbox"/> COMMERCIAL GENERAL LIABILITY				FIRE DAMAGE (Any one fire) \$
	<input type="checkbox"/> CLAIMS MADE OCCUR				MEDICAL (Any one person) \$
	<input type="checkbox"/> OWNER'S & CONT. PROT				PERSONAL & ADV INJURY \$
	<input type="checkbox"/> OWNER'S PROTECTIVE LIABILITY				GENERAL AGGREGATE \$
	<input type="checkbox"/> GENL AGGREGATE LIMIT APPLIES PER: POLICY PROJECT <input type="checkbox"/> LOC				PRODUCTS - COMP/OP AGG \$
B	AUTOMOBILE LIABILITY				COMBINED SINGLE LIMIT (Ea accident) \$
	<input type="checkbox"/> ANY AUTO				BODILY INJURY (Per person) \$
	<input type="checkbox"/> ALL OWNED AUTOS				BODILY INJURY (Per accident) \$
	<input type="checkbox"/> SCHEDULED AUTOS				PROPERTY DAMAGE (Per accident) \$
	<input type="checkbox"/> HIRED AUTOS				
<input type="checkbox"/> NON-OWNED AUTOS					
	GARAGE LIABILITY				AUTO ONLY-EA ACCIDENT \$
	<input type="checkbox"/> ANY AUTO				OTHER THAN AUTO ONLY EA ACC AGG \$
C	EXCESS LIABILITY				EACH OCCURRENCE \$
	<input type="checkbox"/> OCCUR <input type="checkbox"/> CLAIMS MADE				AGGREGATE \$
	<input type="checkbox"/> DEDUCTIBLE				\$
	<input type="checkbox"/> RETENTION \$				\$
D	WORKERS COMPENSATION AND EMPLOYER'S LIABILITY				WC STATU- <input type="checkbox"/> OTHER TORY LIMITS
					E. L. EACH ACCIDENT \$
					E. L. DISEASE-EA EMPLOYEE \$
					E. L. DISEASE-POLICY LIMIT \$
	OTHER				

DESCRIPTION OF OPERATIONS / LOCATION / VEHICLES / EXCLUSIONS ADDED BY ENDORSEMENT / SPECIAL PROVISIONS
 County of Hidalgo shall be named as additional insured on all Commercial General Liability policies.

CERTIFICATE HOLDER	ADDITIONAL INSURED; INSURER LETTER:	CANCELLATION
Hidalgo County Attn: Purchasing Department 2812 S Highway Bus. 281 Edinburg, Texas 78539		SHOULD ANY OF THE ABOVE DESCRIBED POLICIES BY CANCELLED BEFORE THE EXPIRATION DATE THEREOF, THE ISSUING INSURER WILL ENDEAVOR TO MAIL <u>30</u> DAYS WRITTEN NOTICE TO THE CERTIFICATE HOLDER NAMED TO THE LEFT, BUT FAILURE TO DO SO SHALL IMPOSE NO OBLIGATION OR LIABILITY OF ANY KIND UPON THE INSURER, ITS AGENTS OR REPRESENTATIVES. AUTHORIZED REPRESENTATIVE

Insurance Requirement Acknowledgment

I, _____, authorized representative for _____,
Company/Vendor

hereby acknowledge receipt of the County's required insurance limits. Said requirements:

- will be acquired within 10 working days after notification from Purchasing Department of bid awarded by the Hidalgo County Commissioners' Court;
- will acquire additional amounts required to meet the County's requirements within 10 working days after notification from Purchasing Department of bid award by the Hidalgo County Commissioners' Court; currently carry the following:
Automobile Liability: \$ _____ General Liability: \$ _____
- have already been met, see attached copy of insurance certificate.

Authorized Representative

Date

Notice to Bidder:

A certificate of insurance for the required insurance limits shall be provided to the Purchasing Department's Contract Managers in order to qualify for award of bid and to execute a contract between your Company and the County

Failure to provide Certificates of Insurance to the Purchasing Department's Contract Managers will cause the bid award to be rescinded and re-awarded to next lowest bidder. Certificates of Insurance will be monitored and verified on a **quarterly basis** to ensure coverage policy is in place. It is the Company's obligation to maintain the appropriate insurance coverage throughout the term of the contract.

(THIS PAGE MUST BE SUBMITTED WITH BID)

**PROJECT REQUIREMENTS
ACKNOWLEDGMENT**

This is to certify that I, _____, possess all of the APPLICABLE:

1. Licenses: _____.

2. Bonds: _____.

3. Certificates: _____.

4. Permits: _____.

5. Other: _____.

Necessary to carry out the required project. Furthermore, I am providing copies of the required documentation so that, if my company is awarded this bid, I may be eligible to enter into a contract with Hidalgo County and proceed to complete the project in a timely manner.

* Any licenses, bonds, certificates, permits, etc. which are required must be presented as part of the bid packet in order to expedite the bid evaluation process. Failure to provide said documentation will result in the disqualification of your bid.

Authorized Signature

Date

Company

Address

City, State, Zip

(THIS PAGE MUST BE SUBMITTED WITH BID)

EXHIBIT "D"

CONFLICT OF INTEREST QUESTIONNAIRE

FORM CIQ

For vendor or other person doing business with local governmental entity

This questionnaire reflects changes made to the law by H.B. 1491, 80th Leg., Regular Session.

This questionnaire is being filed in accordance with Chapter 176, Local Government Code by a person who has a business relationship as defined by Section 176.001(1-a) with a local governmental entity and the person meets requirements under Section 176.006(a).

By law this questionnaire must be filed with the records administrator of the local governmental entity not later than the 7th business day after the date the person becomes aware of facts that require the statement to be filed. See Section 176.006, Local Government Code.

A person commits an offense if the person knowingly violates Section 176.006. Local Government Code. An offense under this section is a Class C misdemeanor.

OFFICE USE ONLY

Date Received

1 Name of person who has a business relationship with local governmental entity.

2 [] Check this box if you are filing an update to a previously filed questionnaire.

(The law requires that you file an updated completed questionnaire with the appropriate filing authority not later than the 7th business day after the date the originally filed questionnaire becomes incomplete or inaccurate.)

3 Name of local government officer with whom filer has employment or business relationship.

Name of Officer

This section (item 3 including subparts A, B, C & D) must be completed for each officer with whom the filer has an employment or other business relationship as defined by Section 176.001(1-a), Local Government Code. Attach additional pages to this Form CIQ as necessary.

A. Is the local government officer named in this section receiving or likely to receive taxable income, other than investment income, from the filer of the questionnaire?

[] Yes [] No

B. Is the filer of the questionnaire receiving or likely to receive taxable income, other than investment income, from or at the direction of the local government officer named in this section AND the taxable income is not received from the local governmental entity?

[] Yes [] No

C. Is the filer of this questionnaire employed by a corporation or other business entity with respect to which the local government officer serves as an officer or director, or holds an ownership of 10 percent or more?

[] Yes [] No

D. Describe each employment or business relationship with the local government officer named in this section.

4

Signature of person doing business with the governmental entity

Date

HISTORICALLY UNDERUTILIZED BUSINESS (HUB) DECLARATION

The primary objective of the Hidalgo County HUB Program is to ensure Historically Underutilized Businesses receive a fair and equal opportunity for participation in the County's procurement process. This fact holds true for Services (Professional & Non-Professional), Commodities, and Construction contracts and any subcontracts thereto. The program strongly encourages Prime Contractors to provide subcontracting opportunities to Certified Hub Contractors/Vendors. Our goal for HUB contractor/vendor participation, as well as HUB subcontractor participation is 30%. To be considered as a "Certified HUB Contractor/Vendor" the contractor/vendor must have been certified by, and hold a current and valid certification with any of the three agencies listed below.

Have you been Certified as a HUB or an MBE/WBE source?: Yes No

If yes, by whom?: Texas Building & Procurement Commission Other

Indicate Certification No(s): _____ or Are Certificate(s) Attached?: Yes No

LIST OF CERTIFIED HUB SUBCONTRACTORS

(Attach additional pages if necessary)

What percentage of the Bid, RFP, or RFQ is to be subcontracted with Certified HUB sources?:
%

(List HUB Subcontractor information below).

HUB Subcontractor Name: _____ HUB Status:
Certifying Agency (Check all applicable): Texas Building & Procurement Commission
Other

Address: _____ City: _____ State: _____ Zip:

Contact Person: _____ Title: _____ Phone No.: ()

Subcontract Amount: \$_____ Description of Work to be Performed:

HUB Subcontractor Name: _____ HUB Status:
Certifying Agency (Check all applicable): Texas Building & Procurement Commission
Other

Address: _____ City: _____ State: _____ Zip:

Contact Person: _____ Title: _____ Phone No.: ()

Subcontract Amount: \$_____ Description of Work to be Performed:

HUB Subcontractor Name: _____ HUB Status:
Certifying Agency (Check all applicable): Texas Building & Procurement Commission
Other

Address: _____ City: _____ State: _____ Zip:

Contact Person: _____ Title: _____ Phone No.: ()

Subcontract Amount: \$_____ Description of Work to be Performed:

Request for Taxpayer Identification Number and Certification

Give Form to the
 requester. Do not
 send to the IRS.

Print or type See Specific Instructions on page 2.	Name (as shown on your income tax return)	
	Business name/disregarded entity name, if different from above	
	Check appropriate box for federal tax classification (required): <input type="checkbox"/> Individual/sole proprietor <input type="checkbox"/> C Corporation <input type="checkbox"/> S Corporation <input type="checkbox"/> Partnership <input type="checkbox"/> Trust/estate	
	<input type="checkbox"/> Limited liability company. Enter the tax classification (C=C corporation, S=S corporation, P=partnership) ▶	
	<input type="checkbox"/> Other (see instructions) ▶	
Address (number, street, and apt. or suite no.)		Requester's name and address (optional)
City, state, and ZIP code		
List account number(s) here (optional)		

Part I Taxpayer Identification Number (TIN)

Enter your TIN in the appropriate box. The TIN provided must match the name given on the "Name" line to avoid backup withholding. For individuals, this is your social security number (SSN). However, for a resident alien, sole proprietor, or disregarded entity, see the Part I Instructions on page 3. For other entities, it is your employer identification number (EIN). If you do not have a number, see *How to get a TIN* on page 3.

Note. If the account is in more than one name, see the chart on page 4 for guidelines on whose number to enter.

Social security number									
				-			-		
Employer identification number									
				-					

Part II Certification

Under penalties of perjury, I certify that:

1. The number shown on this form is my correct taxpayer identification number (or I am waiting for a number to be issued to me), and
2. I am not subject to backup withholding because: (a) I am exempt from backup withholding, or (b) I have not been notified by the Internal Revenue Service (IRS) that I am subject to backup withholding as a result of a failure to report all interest or dividends, or (c) the IRS has notified me that I am no longer subject to backup withholding, and
3. I am a U.S. citizen or other U.S. person (defined below).

Certification instructions. You must cross out item 2 above if you have been notified by the IRS that you are currently subject to backup withholding because you have failed to report all interest and dividends on your tax return. For real estate transactions, item 2 does not apply. For mortgage interest paid, acquisition or abandonment of secured property, cancellation of debt, contributions to an individual retirement arrangement (IRA), and generally, payments other than interest and dividends, you are not required to sign the certification, but you must provide your correct TIN. See the instructions on page 4.

Sign Here	Signature of U.S. person ▶	Date ▶
------------------	----------------------------	--------

General Instructions

Section references are to the Internal Revenue Code unless otherwise noted.

Purpose of Form

A person who is required to file an information return with the IRS must obtain your correct taxpayer identification number (TIN) to report, for example, income paid to you, real estate transactions, mortgage interest you paid, acquisition or abandonment of secured property, cancellation of debt, or contributions you made to an IRA.

Use Form W-9 only if you are a U.S. person (including a resident alien), to provide your correct TIN to the person requesting it (the requester) and, when applicable, to:

1. Certify that the TIN you are giving is correct (or you are waiting for a number to be issued),
2. Certify that you are not subject to backup withholding, or
3. Claim exemption from backup withholding if you are a U.S. exempt payee. If applicable, you are also certifying that as a U.S. person, your allocable share of any partnership income from a U.S. trade or business is not subject to the withholding tax on foreign partners' share of effectively connected income.

Note. If a requester gives you a form other than Form W-9 to request your TIN, you must use the requester's form if it is substantially similar to this Form W-9.

Definition of a U.S. person. For federal tax purposes, you are considered a U.S. person if you are:

- An individual who is a U.S. citizen or U.S. resident alien,
- A partnership, corporation, company, or association created or organized in the United States or under the laws of the United States,
- An estate (other than a foreign estate), or
- A domestic trust (as defined in Regulations section 301.7701-7).

Special rules for partnerships. Partnerships that conduct a trade or business in the United States are generally required to pay a withholding tax on any foreign partners' share of income from such business. Further, in certain cases where a Form W-9 has not been received, a partnership is required to presume that a partner is a foreign person, and pay the withholding tax. Therefore, if you are a U.S. person that is a partner in a partnership conducting a trade or business in the United States, provide Form W-9 to the partnership to establish your U.S. status and avoid withholding on your share of partnership income.

The person who gives Form W-9 to the partnership for purposes of establishing its U.S. status and avoiding withholding on its allocable share of net income from the partnership conducting a trade or business in the United States is in the following cases:

- The U.S. owner of a disregarded entity and not the entity,
- The U.S. grantor or other owner of a grantor trust and not the trust, and
- The U.S. trust (other than a grantor trust) and not the beneficiaries of the trust.

Foreign person. If you are a foreign person, do not use Form W-9. Instead, use the appropriate Form W-8 (see Publication 515, Withholding of Tax on Nonresident Aliens and Foreign Entities).

Nonresident alien who becomes a resident alien. Generally, only a nonresident alien individual may use the terms of a tax treaty to reduce or eliminate U.S. tax on certain types of income. However, most tax treaties contain a provision known as a "saving clause." Exceptions specified in the saving clause may permit an exemption from tax to continue for certain types of income even after the payee has otherwise become a U.S. resident alien for tax purposes.

If you are a U.S. resident alien who is relying on an exception contained in the saving clause of a tax treaty to claim an exemption from U.S. tax on certain types of income, you must attach a statement to Form W-9 that specifies the following five items:

1. The treaty country. Generally, this must be the same treaty under which you claimed exemption from tax as a nonresident alien.
2. The treaty article addressing the income.
3. The article number (or location) in the tax treaty that contains the saving clause and its exceptions.
4. The type and amount of income that qualifies for the exemption from tax.
5. Sufficient facts to justify the exemption from tax under the terms of the treaty article.

Example. Article 20 of the U.S.-China income tax treaty allows an exemption from tax for scholarship income received by a Chinese student temporarily present in the United States. Under U.S. law, this student will become a resident alien for tax purposes if his or her stay in the United States exceeds 5 calendar years. However, paragraph 2 of the first Protocol to the U.S.-China treaty (dated April 30, 1984) allows the provisions of Article 20 to continue to apply even after the Chinese student becomes a resident alien of the United States. A Chinese student who qualifies for this exception (under paragraph 2 of the first protocol) and is relying on this exception to claim an exemption from tax on his or her scholarship or fellowship income would attach to Form W-9 a statement that includes the information described above to support that exemption.

If you are a nonresident alien or a foreign entity not subject to backup withholding, give the requester the appropriate completed Form W-8.

What is backup withholding? Persons making certain payments to you must under certain conditions withhold and pay to the IRS a percentage of such payments. This is called "backup withholding." Payments that may be subject to backup withholding include interest, tax-exempt interest, dividends, broker and barter exchange transactions, rents, royalties, nonemployee pay, and certain payments from fishing boat operators. Real estate transactions are not subject to backup withholding.

You will not be subject to backup withholding on payments you receive if you give the requester your correct TIN, make the proper certifications, and report all your taxable interest and dividends on your tax return.

Payments you receive will be subject to backup withholding if:

1. You do not furnish your TIN to the requester,
2. You do not certify your TIN when required (see the Part II instructions on page 3 for details),
3. The IRS tells the requester that you furnished an incorrect TIN,
4. The IRS tells you that you are subject to backup withholding because you did not report all your interest and dividends on your tax return (for reportable interest and dividends only), or
5. You do not certify to the requester that you are not subject to backup withholding under 4 above (for reportable interest and dividend accounts opened after 1983 only).

Certain payees and payments are exempt from backup withholding. See the instructions below and the separate instructions for the Requester of Form W-9.

Also see *Special rules for partnerships* on page 1.

Updating Your Information

You must provide updated information to any person to whom you claimed to be an exempt payee if you are no longer an exempt payee and anticipate receiving reportable payments in the future from this person. For example, you may need to provide updated information if you are a C corporation that elects to be an S corporation, or if you no longer are tax exempt. In addition, you must furnish a new Form W-9 if the name or TIN changes for the account, for example, if the grantor of a grantor trust dies.

Penalties

Failure to furnish TIN. If you fail to furnish your correct TIN to a requester, you are subject to a penalty of \$50 for each such failure unless your failure is due to reasonable cause and not to willful neglect.

Civil penalty for false information with respect to withholding. If you make a false statement with no reasonable basis that results in no backup withholding, you are subject to a \$500 penalty.

Criminal penalty for falsifying information. Willfully falsifying certifications or affirmations may subject you to criminal penalties including fines and/or imprisonment.

Misuse of TINs. If the requester discloses or uses TINs in violation of federal law, the requester may be subject to civil and criminal penalties.

Specific Instructions

Name

If you are an individual, you must generally enter the name shown on your income tax return. However, if you have changed your last name, for instance, due to marriage without informing the Social Security Administration of the name change, enter your first name, the last name shown on your social security card, and your new last name.

If the account is in joint names, list first, and then circle, the name of the person or entity whose number you entered in Part I of the form.

Sole proprietor. Enter your individual name as shown on your income tax return on the "Name" line. You may enter your business, trade, or "doing business as (DBA)" name on the "Business name/disregarded entity name" line.

Partnership, C Corporation, or S Corporation. Enter the entity's name on the "Name" line and any business, trade, or "doing business as (DBA) name" on the "Business name/disregarded entity name" line.

Disregarded entity. Enter the owner's name on the "Name" line. The name of the entity entered on the "Name" line should never be a disregarded entity. The name on the "Name" line must be the name shown on the income tax return on which the income will be reported. For example, if a foreign LLC that is treated as a disregarded entity for U.S. federal tax purposes has a domestic owner, the domestic owner's name is required to be provided on the "Name" line. If the direct owner of the entity is also a disregarded entity, enter the first owner that is not disregarded for federal tax purposes. Enter the disregarded entity's name on the "Business name/disregarded entity name" line. If the owner of the disregarded entity is a foreign person, you must complete an appropriate Form W-8.

Note. Check the appropriate box for the federal tax classification of the person whose name is entered on the "Name" line (individual/sole proprietor, Partnership, C Corporation, S Corporation, Trust/estate).

Limited Liability Company (LLC). If the person identified on the "Name" line is an LLC, check the "limited liability company" box only and enter the appropriate code for the tax classification in the space provided. If you are an LLC that is treated as a partnership for federal tax purposes, enter "P" for partnership. If you are an LLC that has filed a Form 8832 or a Form 2553 to be taxed as a corporation, enter "C" for C corporation or "S" for S corporation. If you are an LLC that is disregarded as an entity separate from its owner under Regulation section 301.7701-3 (except for employment and excise tax), do not check the LLC box unless the owner of the LLC (required to be identified on the "Name" line) is another LLC that is not disregarded for federal tax purposes. If the LLC is disregarded as an entity separate from its owner, enter the appropriate tax classification of the owner identified on the "Name" line.

Other entities. Enter your business name as shown on required federal tax documents on the "Name" line. This name should match the name shown on the charter or other legal document creating the entity. You may enter any business, trade, or DBA name on the "Business name/disregarded entity name" line.

Exempt Payee

If you are exempt from backup withholding, enter your name as described above and check the appropriate box for your status, then check the "Exempt payee" box in the line following the "Business name/disregarded entity name," sign and date the form.

Generally, individuals (including sole proprietors) are not exempt from backup withholding. Corporations are exempt from backup withholding for certain payments, such as interest and dividends.

Note. If you are exempt from backup withholding, you should still complete this form to avoid possible erroneous backup withholding.

The following payees are exempt from backup withholding:

1. An organization exempt from tax under section 501(a), any IRA, or a custodial account under section 403(b)(7) if the account satisfies the requirements of section 401(f)(2),
 2. The United States or any of its agencies or instrumentalities,
 3. A state, the District of Columbia, a possession of the United States, or any of their political subdivisions or instrumentalities,
 4. A foreign government or any of its political subdivisions, agencies, or instrumentalities, or
 5. An international organization or any of its agencies or instrumentalities.
- Other payees that may be exempt from backup withholding include:
6. A corporation,
 7. A foreign central bank of issue,
 8. A dealer in securities or commodities required to register in the United States, the District of Columbia, or a possession of the United States,
 9. A futures commission merchant registered with the Commodity Futures Trading Commission,
 10. A real estate investment trust,
 11. An entity registered at all times during the tax year under the Investment Company Act of 1940,
 12. A common trust fund operated by a bank under section 584(a),
 13. A financial institution,
 14. A middleman known in the investment community as a nominee or custodian, or
 15. A trust exempt from tax under section 664 or described in section 4947.

The following chart shows types of payments that may be exempt from backup withholding. The chart applies to the exempt payees listed above, 1 through 15.

IF the payment is for . . .	THEN the payment is exempt for . . .
Interest and dividend payments	All exempt payees except for 9
Broker transactions	Exempt payees 1 through 5 and 7 through 13. Also, C corporations.
Barter exchange transactions and patronage dividends	Exempt payees 1 through 5
Payments over \$600 required to be reported and direct sales over \$5,000 ¹	Generally, exempt payees 1 through 7 ²

¹ See Form 1099-MISC, Miscellaneous Income, and Its Instructions.

² However, the following payments made to a corporation and reportable on Form 1099-MISC are not exempt from backup withholding: medical and health care payments, attorneys' fees, gross proceeds paid to an attorney, and payments for services paid by a federal executive agency.

Part I. Taxpayer Identification Number (TIN)

Enter your TIN in the appropriate box. If you are a resident alien and you do not have and are not eligible to get an SSN, your TIN is your IRS individual taxpayer identification number (ITIN). Enter it in the social security number box. If you do not have an ITIN, see *How to get a TIN* below.

If you are a sole proprietor and you have an EIN, you may enter either your SSN or EIN. However, the IRS prefers that you use your SSN.

If you are a single-member LLC that is disregarded as an entity separate from its owner (see *Limited Liability Company (LLC)* on page 2), enter the owner's SSN (or EIN, if the owner has one). Do not enter the disregarded entity's EIN. If the LLC is classified as a corporation or partnership, enter the entity's EIN.

Note. See the chart on page 4 for further clarification of name and TIN combinations.

How to get a TIN. If you do not have a TIN, apply for one immediately. To apply for an SSN, get Form SS-5, Application for a Social Security Card, from your local Social Security Administration office or get this form online at www.ssa.gov. You may also get this form by calling 1-800-772-1213. Use Form W-7, Application for IRS Individual Taxpayer Identification Number, to apply for an ITIN, or Form SS-4, Application for Employer Identification Number, to apply for an EIN. You can apply for an EIN online by accessing the IRS website at www.irs.gov/businesses and clicking on Employer Identification Number (EIN) under Starting a Business. You can get Forms W-7 and SS-4 from the IRS by visiting IRS.gov or by calling 1-800-TAX-FORM (1-800-829-3676).

If you are asked to complete Form W-9 but do not have a TIN, write "Applied For" in the space for the TIN, sign and date the form, and give it to the requester. For interest and dividend payments, and certain payments made with respect to readily tradable instruments, generally you will have 60 days to get a TIN and give it to the requester before you are subject to backup withholding on payments. The 60-day rule does not apply to other types of payments. You will be subject to backup withholding on all such payments until you provide your TIN to the requester.

Note. Entering "Applied For" means that you have already applied for a TIN or that you intend to apply for one soon.

Caution: A disregarded domestic entity that has a foreign owner must use the appropriate Form W-8.

Part II. Certification

To establish to the withholding agent that you are a U.S. person, or resident alien, sign Form W-9. You may be requested to sign by the withholding agent even if item 1, below, and items 4 and 5 on page 4 indicate otherwise.

For a joint account, only the person whose TIN is shown in Part I should sign (when required). In the case of a disregarded entity, the person identified on the "Name" line must sign. Exempt payees, see *Exempt Payee* on page 3.

Signature requirements. Complete the certification as indicated in items 1 through 3, below, and items 4 and 5 on page 4.

1. Interest, dividend, and barter exchange accounts opened before 1984 and broker accounts considered active during 1983. You must give your correct TIN, but you do not have to sign the certification.

2. Interest, dividend, broker, and barter exchange accounts opened after 1983 and broker accounts considered inactive during 1983. You must sign the certification or backup withholding will apply. If you are subject to backup withholding and you are merely providing your correct TIN to the requester, you must cross out item 2 in the certification before signing the form.

3. Real estate transactions. You must sign the certification. You may cross out item 2 of the certification.

4. Other payments. You must give your correct TIN, but you do not have to sign the certification unless you have been notified that you have previously given an incorrect TIN. "Other payments" include payments made in the course of the requester's trade or business for rents, royalties, goods (other than bills for merchandise), medical and health care services (including payments to corporations), payments to a nonemployee for services, payments to certain fishing boat crew members and fishermen, and gross proceeds paid to attorneys (including payments to corporations).

5. Mortgage interest paid by you, acquisition or abandonment of secured property, cancellation of debt, qualified tuition program payments (under section 529), IRA, Coverdell ESA, Archer MSA or HSA contributions or distributions, and pension distributions. You must give your correct TIN, but you do not have to sign the certification.

Note. If no name is circled when more than one name is listed, the number will be considered to be that of the first name listed.

Secure Your Tax Records from Identity Theft

Identity theft occurs when someone uses your personal information, such as your name, social security number (SSN), or other identifying information, without your permission, to commit fraud or other crimes. An identity thief may use your SSN to get a job or may file a tax return using your SSN to receive a refund.

To reduce your risk:

- Protect your SSN,
- Ensure your employer is protecting your SSN, and
- Be careful when choosing a tax preparer.

If your tax records are affected by identity theft and you receive a notice from the IRS, respond right away to the name and phone number printed on the IRS notice or letter.

If your tax records are not currently affected by identity theft but you think you are at risk due to a lost or stolen purse or wallet, questionable credit card activity or credit report, contact the IRS Identity Theft Hotline at 1-800-908-4490 or submit Form 14039.

For more information, see Publication 4535, Identity Theft Prevention and Victim Assistance.

Victims of identity theft who are experiencing economic harm or a system problem, or are seeking help in resolving tax problems that have not been resolved through normal channels, may be eligible for Taxpayer Advocate Service (TAS) assistance. You can reach TAS by calling the TAS toll-free case intake line at 1-877-777-4778 or TTY/TDD 1-800-829-4059.

Protect yourself from suspicious emails or phishing schemes. Phishing is the creation and use of email and websites designed to mimic legitimate business emails and websites. The most common act is sending an email to a user falsely claiming to be an established legitimate enterprise in an attempt to scam the user into surrendering private information that will be used for identity theft.

The IRS does not initiate contacts with taxpayers via emails. Also, the IRS does not request personal detailed information through email or ask taxpayers for the PIN numbers, passwords, or similar secret access information for their credit card, bank, or other financial accounts.

If you receive an unsolicited email claiming to be from the IRS, forward this message to phishing@irs.gov. You may also report misuse of the IRS name, logo, or other IRS property to the Treasury Inspector General for Tax Administration at 1-800-368-4484. You can forward suspicious emails to the Federal Trade Commission at: spam@uce.gov or contact them at www.ftc.gov/idtheft or 1-877-IDTHEFT (1-877-438-4338).

Visit IRS.gov to learn more about identity theft and how to reduce your risk.

What Name and Number To Give the Requester

For this type of account:	Give name and SSN of:
1. Individual	The individual
2. Two or more individuals (joint account)	The actual owner of the account or, if combined funds, the first individual on the account ¹
3. Custodian account of a minor (Uniform Gift to Minors Act)	The minor ²
4. a. The usual revocable savings trust (grantor is also trustee) b. So-called trust account that is not a legal or valid trust under state law	The grantor-trustee ³ The actual owner ¹
5. Sole proprietorship or disregarded entity owned by an individual	The owner ³
6. Grantor trust filing under Optional Form 1099 Filing Method 1 (see Regulation section 1.671-4(b)(2)(i)(A))	The grantor ³
For this type of account:	Give name and EIN of:
7. Disregarded entity not owned by an individual	The owner
8. A valid trust, estate, or pension trust	Legal entity ¹
9. Corporation or LLC electing corporate status on Form 8832 or Form 2553	The corporation
10. Association, club, religious, charitable, educational, or other tax-exempt organization	The organization
11. Partnership or multi-member LLC	The partnership
12. A broker or registered nominee	The broker or nominee
13. Account with the Department of Agriculture in the name of a public entity (such as a state or local government, school district, or prison) that receives agricultural program payments	The public entity
14. Grantor trust filing under the Form 1041 Filing Method or the Optional Form 1099 Filing Method 2 (see Regulation section 1.671-4(b)(2)(i)(B))	The trust

¹ List first and circle the name of the person whose number you furnish. If only one person on a joint account has an SSN, that person's number must be furnished.

² Circle the minor's name and furnish the minor's SSN.

³ You must show your individual name and you may also enter your business or "DBA" name on the "Business name/disregarded entity" name line. You may use either your SSN or EIN (if you have one), but the IRS encourages you to use your SSN.

⁴ List first and circle the name of the trust, estate, or pension trust. (Do not furnish the TIN of the personal representative or trustee unless the legal entity itself is not designated in the account title.) Also see *Special rules for partnerships* on page 1.

*Note. Grantor also must provide a Form W-9 to trustee of trust.

Privacy Act Notice

Section 6109 of the Internal Revenue Code requires you to provide your correct TIN to persons (including federal agencies) who are required to file information returns with the IRS to report interest, dividends, or certain other income paid to you; mortgage interest you paid; the acquisition or abandonment of secured property; the cancellation of debt; or contributions you made to an IRA, Archer MSA, or HSA. The person collecting this form uses the information on the form to file information returns with the IRS, reporting the above information. Routine uses of this information include giving it to the Department of Justice for civil and criminal litigation and to cities, states, the District of Columbia, and U.S. possessions for use in administering their laws. The information also may be disclosed to other countries under a treaty, to federal and state agencies to enforce civil and criminal laws, or to federal law enforcement and intelligence agencies to combat terrorism. You must provide your TIN whether or not you are required to file a tax return. Under section 3406, payers must generally withhold a percentage of taxable interest, dividend, and certain other payments to a payee who does not give a TIN to the payer. Certain penalties may also apply for providing false or fraudulent information.

**Certification
Regarding Debarment, Suspension and Ineligibility**

As is required by the Federal Regulations Implementing Executive Order 12549, Debarment and Suspension, 45 CFR Part 76, Government-wide Debarment and Suspension, the applicant certifies, to the best of his or her knowledge and belief, that both it and its principals:

- a. Are not presently debarred, suspended, proposed for debarment, declared ineligible, or voluntarily excluded from participation in this transaction by any federal department or agency;
- b. Have not within a three-year period preceding this bid proposal and/or application been convicted of or had a civil judgment rendered against them for commission of fraud or a criminal offense in connection with obtaining, attempting to obtain, or performing a public (federal, state, or local) transaction or contract under a public transaction, violation of federal or state antitrust statutes or commission of embezzlement, theft, forgery, bribery, falsification or destruction of records, making false statements, or receiving stolen property;
- c. Are not presently indicted for or otherwise criminally or civilly charged by a government entity with commission of any of the offenses enumerated herein; and
- d. Have not within a three-year period preceding this bid proposal and/or application had one or more public transactions terminated for cause or default.

Signature: _____
Print Name: _____
Title: _____
Telephone Number: _____
Date: _____

If the bidder is unable to certify to all of the statements in this Certification, such bidder should attach an explanation to this proposal.

THE STATE OF TEXAS §
§
COUNTY OF HIDALGO §

**SERVICE CONTRACT
C-16-012-00-00**

THIS CONTRACT is made and entered into this ____ day of _____, 2015 by and between the **COUNTY OF HIDALGO, TEXAS** ("County"), and _____ a Corporation. ("Company").

WHEREAS, Company responded to advertised notices for bids for “Sign Language Interpreting Services For Hearing Impaired (Courtroom & Non-Courtroom) (AS NEEDED BASIS)” for Hidalgo County (the "Services"); and

WHEREAS, Company submitted a bid to provide services in accordance with the specifications as bid, a copy of Request for Bid (RFB) Procurement Packet being attached hereto as Exhibits "A" (the "RFB") and Company's bid being attached hereto as Exhibit "B" (the "Bid Page"), and incorporated herein for all purposes; and

WHEREAS, in recognition of and in consideration of Company's Contract to perform the Services in accordance with the RFB, the Commissioners' Court of County awarded the bid to Company.

NOW, THEREFORE, in mutual consideration of the foregoing and further consideration of the following, the parties hereto agree as follows:

1. County and Company hereby agrees that this Contract is entered into in order to provide the Services to locations at Hidalgo County. This Contract does not extend to any third parties any duties or benefits conferred in any manner hereunder or otherwise.

2. Company hereby promises and agrees to render and provide, during the term of this Contract, and shall be obligated to render and provide the Services in accordance with the RFB within **Hidalgo County** following a request for Services by the Department Head, Commissioner, Sheriff or his designated agent. Company agrees in performing the Services that it will use proper professional standards, comply with any and all appropriate laws and regulations in providing the Services, and devote such time as is necessary to safely and efficiently provide the Services.

3. This Contract shall be for a period beginning February 5, 2016 and ending on February 4, 2017 and may be extended at the sole discretion of County for an additional two (2) one (1) year periods, unless this Contract is terminated pursuant to the provisions herein, whichever occurs first. County also reserves the right to continue this bid for an additional sixty (60) day Grace Period, under the same rates, terms and conditions.

4. As a condition of this Contract, Company shall hold and maintain throughout the term of this Contract all licenses and permits required, or which may be required by any authority during the term hereof to provide the Services.

5. All trucks or vehicles operated by the Company to perform the Services shall contain all equipment required by any authority to operate on streets and roads and all persons in the employ of Company who operate such trucks or vehicles shall have the required licenses, qualifications, skill and expertise to perform such Services and shall comply with all laws, rules and regulations prescribed by any agency or authority having jurisdiction with regard to the operation of such trucks or vehicles in providing the Services.

6. As consideration for rendering the Service provided for in this Contract, the County

agrees to pay Company the amounts specified in Exhibit "B" attached hereto payable against written invoice submitted by Company.

7. Company shall provide insurance in force on all its vehicles and all persons connected with providing services under this Contract naming County as an additional insured (with the coverages and in the amounts described on Exhibit "C" attached hereto and incorporated herein at this point for all purposes), and shall furnish to County certificates of such insurance coverage.

8. Company shall provide a sufficient number of trucks, vehicles, personnel and equipment available to safely and efficiently provide the Services.

9. Company shall indemnify and hold harmless County, its elected officials, employees and agents from any and all claims, damages, losses, and expenses including attorney's fees for the defense of any action against County arising out of, resulting from, or connected with the provision of the Service by Company under this Contract. Said indemnity shall cover any act or failure to act by the Company, its agents or employees.

10. This Contract shall not be assignable in whole or in part by either party without prior written consent of the other party.

11. It is expressly agreed that this Contract and the performance by the parties hereunder does not create any agency relationship or master-servant relationship, which County has no supervision of the performance of the Services provided by Company, and that Company is an independent contractor under this Contract.

12. Any notice required or permitted to be given hereunder shall be in writing and shall be delivered personally or sent by certified mail, postage prepaid, as set forth below:

If to County: **The County of Hidalgo**
 Attn: County Judge
 100 E. Cano
 Edinburg, Texas 78539

If to Company **COMPANY'S NAME**
 ADDRESS

13. In case any one or more of the provisions contained in this Contract shall for any reason be held to be invalid, illegal or unenforceable in any respect, such invalidity, illegality, or unenforceability shall not affect any other provision thereof and this Contract shall be construed as if such invalid, illegal, or unenforceable provision had never been contained herein.

14. This Contract may be terminated by County without cause upon thirty (30) days written notice.

15. This Contract shall be binding upon and inure to the benefit of and be enforceable by the parties hereto and their respective heirs, executors, administrators, legal representatives, successors, and assigns where permitted by this Contract.

16. This Contract shall be governed by and construed in accordance with the laws of the State of Texas and shall be performable in Hidalgo County.

17. **Commitment of Current Revenues Only.** In the event that, during any term hereof, the Commissioners Court does not appropriate sufficient funds to meet the obligations of County under this Contract, County may terminate this Contract upon ninety (90) days written notice to Company. County agrees, however, to use reasonable efforts to secure funds necessary for the continued performance of this Contract. The parties intend this provision to be a continuing right to terminate this Contract at the expiration of each budget period of County pursuant to the provisions of Tex. Loc. Govt. Code Ann. ' 271.903 (Vernon Supp. 1996).

18. **Entire Agreement.** This Contract contains the entire contract between the parties hereto, and each party acknowledges that neither has made (either directly or through any agent or representative) any representations or agreements in connection with this Contract not specifically set forth herein. This Contract may be modified or amended only by agreement in writing executed by County and Company, and not otherwise.

19. **Immunities.** Nothing in this Contract is intended to and County does not hereby waive, release or relinquish any right to assert any of the defenses County enjoys by virtue of the state or federal constitution, laws, rules or regulations, and any sovereign, official or qualified immunity available to County as to any claim or action of any person, entity, or individual against County.

WITNESS our hands in duplicate originals this _____ day of _____, 2015.

COUNTY OF HIDALGO

ATTEST:

By: _____
Ramon Garcia, County Judge

Arturo Guajardo Jr., County Clerk

COMPANY:

By: _____
Printed Name: _____
Title: _____

APPROVED AS TO FORM:
Atlas & Hall, L.L.P.

By: Steve L. Crain

EXHIBIT “A”
REQUEST FOR BID
(RFB)
PROCUREMENT
PACKET

EXHIBIT "B"
REQUEST FOR BID
BID PAGE

DRAFT

EXHIBIT "C"

CERTIFICATE OF
INSURANCE

DRAFT

EXHIBIT “B”
REQUEST FOR BID
BID PAGE



10 Exhibit "B" – Pricing

EXHIBIT "B"

Bid Page
HIDALGO COUNTY

"Sign Language Interpreting Services for Hearing Impaired-(Courtroom and Non-Courtroom)"

Bid No.:2016-012-12-16-HGO

NIGP Commodity Code: 961-75 Sign Language Services for Hearing Impaired

Prices shall include all costs associated with the provision of all services, including administrative fees, if any, and local travel related costs.

<u>HOURS OF SERVICE</u>	<u>NON-COURTROOM Interpreting Assignments</u>	<u>COURTROOM Interpreting Assignments</u>
BUSINESS HOURLY RATES – CERTIFIED INTERPRETER (Scheduled at least 24 hours In Advance) Monday through Friday (8:00 a.m-6:00 p.m.)	\$ 72.00	\$ 72.00
BUSINESS HOURLY RATES – CERTIFIED INTERPRETER (Scheduled less than 24 hours In advance) Monday through Friday (8:00 a.m-6:00 p.m.)	\$ 73.50	\$ 73.50
BUSINESS HOURLY RATES – NON-CERTIFIED INTERPRETER (Scheduled at least 24 hours in Advance) Monday through Friday (8:00 a.m-6:00 p.m.)	\$ 70.00	\$ 70.00
BUSINESS HOURLY RATES – NON-CERTIFIED INTERPRETER (Scheduled less than 24 hours In advance) Monday through Friday (8:00 a.m-6:00 p.m.)	\$ 71.00	\$ 72.00
EXTENDED SERVICE HOURLY RATES – CERTIFIED INTERPRETER (Between 6:00 p.m. and 8:00 a.m.) Monday through Friday and Weekends	\$ 77.50	\$ 77.50
EXTENDED SERVICE HOURLY RATES – NON-CERTIFIED INTERPRETER (Between 6:00 p.m. and 8:00 a.m.) Monday through Friday and Weekends	\$ 75.00	\$ 75.00
EMERGENCY/ HOLIDAYS – CERTIFIED INTERPRETERS (as defined by the Texas Commission for the Deaf and Hard of Hearing) Emergency interpreting service situations which are potentially life threatening or pose a threat to the clients' well-being during any time of the day or night. Holiday interpreting service situations apply to any Federal or County observed holiday.	\$ 77.50	\$ 77.50
EMERGENCY/ HOLIDAYS – NON-CERTIFIED INTERPRETERS (as defined by the Texas Commission for the Deaf and Hard of Hearing) Emergency interpreting service situations which are potentially life threatening or pose a threat to the clients' well-being during any time of the day or night. Holiday interpreting service situations apply to any Federal or County observed holiday.	\$ 75.00	\$ 75.00
LESS THAN 24 HOUR CANCELLATION FEE CERTIFIED INTERPRETER	\$ 144.00	\$ 144.00
LESS THAN 24 HOUR CANCELLATION FEE NON-CERTIFIED INTERPRETER	\$ 140.00	\$ 140.00

OPENED
9:36 12-16-15

Witnessed

YH



11 Bidder's Information

BIDDER'S INFORMATION:

I/We the undersigned hereby certify that I/We am/are a duly authorized official of the company and have the authority to sign on behalf of the company and assure that all statements made in the bid are true. I/We agree to furnish and deliver the specified items/services at the prices stated herein, and have read, understand, and agree to the terms and conditions contained herein and on all of the attachments.

BIDDER/COMPANY NAME: ALLWORLD LANGUAGE CONSULTANTS, INC.

ADDRESS: 172 ROLLINS AVENUE

CITY/STATE/ZIP CODE: ROCKVILLE, MD 20852-4005

PHONE & FAX NO'S: (301)881-8884 EXT 1319 – (301)881-6877

CELLULAR NO: (301)385-6518

E-MAIL ADDRESS: Scandiffio@alcinc.com

AUTHORIZED SIGNATURE:

PRINTED NAME: CARLOS A. SCANDIFFIO

TITLE: PRINCIPAL

EXHIBIT “C”

CERTIFICATE OF
INSURANCE

THIS CERTIFICATE IS ISSUED AS A MATTER OF INFORMATION ONLY AND CONFERS NO RIGHTS UPON THE CERTIFICATE HOLDER. THIS CERTIFICATE DOES NOT AFFIRMATIVELY OR NEGATIVELY AMEND, EXTEND OR ALTER THE COVERAGE AFFORDED BY THE POLICIES BELOW. THIS CERTIFICATE OF INSURANCE DOES NOT CONSTITUTE A CONTRACT BETWEEN THE ISSUING INSURER(S), AUTHORIZED REPRESENTATIVE OR PRODUCER, AND THE CERTIFICATE HOLDER.

IMPORTANT: If the certificate holder is an ADDITIONAL INSURED, the policy(ies) must be endorsed. If SUBROGATION IS WAIVED, subject to the terms and conditions of the policy, certain policies may require an endorsement. A statement on this certificate does not confer rights to the certificate holder in lieu of such endorsement(s).

PRODUCER Henry A Latimer & Son Inc 4701 Sangamore Rd. Suite S-250 Bethesda, MD 20816	CONTACT NAME: PHONE (A/C, No, Ext): 301.229.1500 FAX (A/C, No): 301.320.2458 E-MAIL ADDRESS:														
	<table border="1"> <thead> <tr> <th>INSURER(S) AFFORDING COVERAGE</th> <th>NAIC #</th> </tr> </thead> <tbody> <tr> <td>INSURER A: Travelers Indemnity Co - A++</td> <td>25658</td> </tr> <tr> <td>INSURER B: AXIS - A++</td> <td>37273</td> </tr> <tr> <td>INSURER C:</td> <td></td> </tr> <tr> <td>INSURER D:</td> <td></td> </tr> <tr> <td>INSURER E:</td> <td></td> </tr> <tr> <td>INSURER F:</td> <td></td> </tr> </tbody> </table>		INSURER(S) AFFORDING COVERAGE	NAIC #	INSURER A: Travelers Indemnity Co - A++	25658	INSURER B: AXIS - A++	37273	INSURER C:		INSURER D:		INSURER E:		INSURER F:
INSURER(S) AFFORDING COVERAGE	NAIC #														
INSURER A: Travelers Indemnity Co - A++	25658														
INSURER B: AXIS - A++	37273														
INSURER C:															
INSURER D:															
INSURER E:															
INSURER F:															
INSURED Allworld Language Consultants, Inc. 172 Rollins Avenue Suites 3 & 3A Rockville, MD 20852															

COVERAGES **CERTIFICATE NUMBER: County of Hidalgo, TX** **REVISION NUMBER:**

THIS IS TO CERTIFY THAT THE POLICIES OF INSURANCE LISTED BELOW HAVE BEEN ISSUED TO THE INSURED NAMED ABOVE FOR THE POLICY PERIOD INDICATED. NOTWITHSTANDING ANY REQUIREMENT, TERM OR CONDITION OF ANY CONTRACT OR OTHER DOCUMENT WITH RESPECT TO WHICH THIS CERTIFICATE MAY BE ISSUED OR MAY PERTAIN, THE INSURANCE AFFORDED BY THE POLICIES DESCRIBED HEREIN IS SUBJECT TO ALL THE TERMS, EXCLUSIONS AND CONDITIONS OF SUCH POLICIES. LIMITS SHOWN MAY HAVE BEEN REDUCED BY PAID CLAIMS.

INSR LTR	TYPE OF INSURANCE	ADDL SUBR INSR WVD	POLICY NUMBER	POLICY EFF (MM/DD/YYYY)	POLICY EXP (MM/DD/YYYY)	LIMITS
A	GENERAL LIABILITY <input checked="" type="checkbox"/> COMMERCIAL GENERAL LIABILITY <input type="checkbox"/> CLAIMS-MADE <input checked="" type="checkbox"/> OCCUR GEN'L AGGREGATE LIMIT APPLIES PER: <input checked="" type="checkbox"/> POLICY <input type="checkbox"/> PRO-JECT <input type="checkbox"/> LOC	X	660481X5056	01/05/2016	01/05/2017	EACH OCCURRENCE \$ 1,000,000
	DAMAGE TO RENTED PREMISES (Ea occurrence) \$ 300,000 MED EXP (Any one person) \$ 10,000 PERSONAL & ADV INJURY \$ 1,000,000 GENERAL AGGREGATE \$ 2,000,000 PRODUCTS - COMP/OP AGG \$ 2,000,000					
A	UMBRELLA LIAB <input checked="" type="checkbox"/> OCCUR EXCESS LIAB <input type="checkbox"/> CLAIMS-MADE DED RETENTION \$		CUP6F551107	01/05/2016	01/05/2017	EACH OCCURRENCE \$ 1,000,000 AGGREGATE \$ 1,000,000
	WORKERS COMPENSATION AND EMPLOYERS' LIABILITY ANY PROPRIETOR/PARTNER/EXECUTIVE OFFICER/MEMBER EXCLUDED? (Mandatory in NH) If yes, describe under DESCRIPTION OF OPERATIONS below		UB840D0739	01/05/2016	01/05/2017	<input checked="" type="checkbox"/> WC STATUTORY LIMITS <input type="checkbox"/> OTHER E.L. EACH ACCIDENT \$ 1,000,000 E.L. DISEASE - EA EMPLOYEE \$ 1,000,000 E.L. DISEASE - POLICY LIMIT \$ 1,000,000
B	Professional Liability		55600651710	02/02/2015	02/02/2016	\$2,000,000

DESCRIPTION OF OPERATIONS / LOCATIONS / VEHICLES (Attach ACORD 101, Additional Remarks Schedule, if more space is required)

County of Hidalgo, Texas is an additional insured

Sign Language Interpreting Services

CERTIFICATE HOLDER

CANCELLATION

Hidalgo County Purchasing Department
 2812 S Business Highway 281
 Edinburg, Texas 78539

SHOULD ANY OF THE ABOVE DESCRIBED POLICIES BE CANCELLED BEFORE THE EXPIRATION DATE THEREOF, NOTICE WILL BE DELIVERED IN ACCORDANCE WITH THE POLICY PROVISIONS.

AUTHORIZED REPRESENTATIVE

 Richard Latimer, Sr.

AI-52678

Purchasing Department 12.
C. 1.

CC - REGULAR

Meeting Date: 01/26/2016

Submitted Marty Salazar, PURCHASING DEPT.

For:

Submitted By: Sandy Suarez, PURCHASING DEPT.

Department: PURCHASING DEPT.

Information

CAPTION

Presentation of Sole bid received as detailed in tabulation sheet contained herein meeting all specifications and/or requirements for the purpose of award and approval of contract and subject to compliance with HB23 and HB1295 (if and when applicable)- for Request for Bid titled: Hidalgo County Pct1- "Lease of Parcel for Citizen Collection Site(s) 1 in Mercedes and 1 in Donna" through project No.: 2016-013-12-09-SGS.

BACKGROUND

1. 3 packets sent out with one response received for the Mercedes location only.
2. Current contract expires February 03, 2016
3. New contract commences February 04, 2016
4. Contract document was reviewed and approved by Legal Counsel as to form.

Fiscal Impact

FISCAL YEAR: 2016 ACCT. #: 6-1100-432-00-121-001-0-441

FUNDS AVAILABLE Y/N?: Y MATCHING FUNDS Y/N?: N

BUDGETARY IMPACT:

Pct 1 - \$12,197.00 as of 01/20/16

Attachments

Recommendation, tab , participation log agreement

Form Review

Inbox	Reviewed By	Date
Auditor's Office	Monica Badillo	01/22/2016 04:11 PM
Form Started By: Sandy Suarez		Started On: 12/11/2015 04:28 PM
Final Approval Date: 01/22/2016		



MEMORANDUM

To: Honorable AC Cuellar, Jr.
H.C. Commissioner Pct. 1
Attn: Raul Lozano/Katia Garcia

From: Sandy Suarez ^{CHS}
Purchasing Dept., Buyer II

Date: December 10, 2015

RE: Bid No. 2016-013-12-09-SGS
"Lease Parcel for Citizen Collection Site(s) - 1 in Mercedes and 1 in Donna"

We received a sole (1) response to the above mentioned project. Enclosed you will find a copy of the Tabulation sheet & Bid page for your review and recommendation/non-recommendation. Please review and reply with your recommendation.

Please indicate your recommendation or any concerns on the space provided below and reply to the Purchasing Dept. via fax to (956)-292-7612 or via email to me sandy.suarez@co.hidalgo.tx.us, by no later than **December 16, 2015 @ 10:00 A.M.** in order to place this on the agenda for the next Commissioners Court Meeting,

If you should have any questions or need additional information please contact me at (956) 318-2626 x 4860

<u>AWARD TO VENDOR(S):</u>	<u>RECOMMENDATION (BASIS)</u>
Ray Jones	sole response Mercedes Location
<u>ACCOUNT: 51100-432-00-121-001-0-441 :</u>	

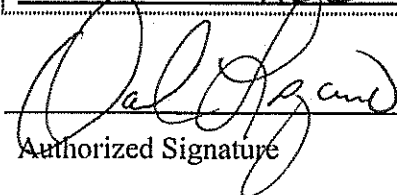
Authorized Signature

Raul Lozano
Printed Name

12/15/15
Date

**HIDALGO COUNTY PURCHASING DEPARTMENT
 BID TABULATION SHEET**

DEPARTMENT NAME: HIDALGO COUNTY

BID OPENING DATE: December 09, 2015

BID OPENING TIME: 9:30 A.M.

**DESCRIPTION OF BID: RFB- "LEASE OF PARCEL FOR CITIZEN COLLECTION SITE(S):
 ONE (1) IN MERCEDES AND ONE (1) IN DONNA"**

BID NO: 2016-013-12-09-SGS

RFB#	NAME OF COMPANY	COST
#01	SOLE BIDDER Ray Jones	<p><u>Location A:</u> South of 493 and Mile West, Donna,Tx.- <u>No Bid</u></p> <p><u>Location B:</u> I Mile South of Bus. 83 and Mile 1 East, Mercedes, TX: <u>\$450.00</u> per month</p>

**HIDALGO COUNTY PURCHASING DEPARTMENT
COMPARISION SHEET**

DEPARTMENT NAME: HIDALGO COUNTY

BID OPENING DATE: DECEMBER 09, 2015

BID OPENING TIME: 9:30 A.M.

**DESCRIPTION OF BID: RFB- "LEASE OF PARCEL FOR CITIZEN COLLECTION SITE(S):
ONE (1) IN MERCEDES AND ONE (1) IN DONNA"**

BID NO: 2016-013-12-09-SGS

NAME OF COMPANY	CURRENT COST	PROPOSED BIDDER	DIFFERENCE
Richard Cohrs	Donna, Tx. <u>\$ 400.00 per month</u> So. of 493 and Mile West	NO BID	\$ 0.00
Ray Jones	Mercedes, TX: <u>\$400.00 per month</u> I Mile So. Of Bus. 83 and Mile 1 East	Donna, TX. <u>No Bid</u> Mercedes, TX. <u>\$ 450.00 per Month</u>	\$ 50.00

THE STATE OF TEXAS §
§
COUNTY OF HIDALGO §

LEASE
C-16-013-01-26

THIS LEASE (the "Lease") is made on this **26th** day of **January, 2016**, by and between **Ray Jones**, a resident of Hidalgo County, Texas, referred to in this Lease as Lessor, and **The County of Hidalgo**, referred to in this Lease as Lessee.

In consideration of the mutual covenants and agreements set forth in this Lease, and other good and valuable consideration, Lessee submitted a bid in response to the Notice of Bid in accordance with the specifications as bid, a copy of such specifications and bid being attached hereto as Exhibits "A" and "B" (Lessess's Bid") respectively, and incorporated herein for all purposes (the "RFB Packet"). Lessor demises and leases to Lessee, and Lessee leases from Lessor, that certain real property described on Exhibit "A-1", attached hereto for the purpose of establishing citizen collection sites (the "Citizen Collection Site") within certain areas of Hidalgo County Precinct One. These premises leased hereunder are referred to in this Lease as "the Premises" or "the Leased Premises."

ARTICLE 1. TERM

Term of Lease

1.1 Except as otherwise herein provided, the term of this Lease shall be for a period of **one (1) year** commencing on **February 4, 2016** (as hereinafter defined) and ending on **February 3, 2017** (as hereunder defined) unless sooner terminated as provided in this Lease, or unless renewed and extended in accordance with Paragraph 1.2, hereof.

Renewal or Termination

1.2. Lessee shall have the right and option to renew and extend the term of this Lease for an additional two (2)-one (1) year terms and additional sixty (60) day grace period under the same rates, terms and conditions. If Lessee desires to renew and extend the term of this Lease for such renewal period, Lessee must give Lessor written notice of such renewal at least sixty (60) days prior to the termination of the initial lease term if Lessee desires to renew for the renewal period. Any renewal or extension of this Lease shall be on the same terms and conditions as provided herein. This Lease shall terminate and become null and void without further notice on the expiration of the term specified in Article 1.1, unless sooner terminated or renewed and extended in accordance with this Article 1.4; and any holding over by Lessee after the expiration of that term shall not constitute a renewal of the Lease or give Lessee any rights under the Lease in or to the Leased Premises.

Holdover

1.3 If Lessee holds over and continues in possession of the Leased Premises after expiration of the term of this Lease, Lessee will be deemed to be occupying the Premises on the basis of a tenancy at sufferance, subject to all of the terms and conditions of this Lease. The inclusion of this Article 1.2 shall not be construed as Lessor's consent for Lessee to hold over.

Termination

1.4 Lessee may declare this Lease, and all rights and interest created by it, to be terminated upon giving the other party thirty (30) days written notice. Upon Lessee electing to terminate, this Lease shall cease and come to an end as if the day of the termination election were the day originally fixed in the Lease for its expiration.

Lessor's Warranty of Quiet Enjoyment

1.5. Lessor covenants and agrees that Lessee on paying the rent herein provided for and observing and keeping the covenants, conditions, and terms of this Lease on Lessee's part to be kept or performed, shall lawfully and quietly hold, occupy, and enjoy the Leased Premises during the term of this Lease without hindrance or molestation of Lessor or any person claiming under Lessor except such portion of the Leased Premises, if any, as shall be taken under the power of eminent domain.

ARTICLE 2. RENT

Base Rent

2.1 Lessee agrees to pay to Lessor, during the term hereof, a monthly rental equal to the product of **Four Hundred Fifty Dollars (\$450.00)** per month, of the Premises as described in Exhibit B. In the event the Commencement Date is a day other than the first day of the month, the rent for the period from the commencement date to the last day of the month shall be prorated by dividing the monthly rental by the number of calendar days in the month, and multiplying the result by the number of days remaining in the month that includes the Commencement.

Time and Manner of Payment

2.2 All rent due under this article shall be paid by Lessee on a monthly basis and in advance, on the 1st business day of each month commencing on the Commencement Date. All installments of rent shall be paid in lawful money of the United States to the Lessor in such location or locations as Lessor shall from time to time designate by written notice to Lessee. Any rent due for any partial month at the beginning or the end of the term hereof shall be prorated on the basis of a thirty day month.

Taxes

2.3 Lessor is responsible for rendering and paying all real estate taxes on the Property. Lessee shall be responsible for taxes, if any, on lessee's personal property located on the Premises.

ARTICLE 3. USE OF PREMISES

Permitted Use

3.1 Lessee may use the premises for landfill transfer and any other lawful purposes.

Waste, Nuisance, or Illegal Use

3.2 Lessee shall not use, or permit the use of, the Premises in any manner that results in waste of the Premises or constitutes a nuisance or violates any statute, ordinance, rule or regulation applicable to the premises or for any illegal purpose.

ARTICLE 4.

OMIT

ARTICLE 5. UTILITIES

Intentionally Deleted

ARTICLE 6. ALTERATIONS, ADDITIONS, AND IMPROVEMENTS

Consent of Lessor

6.1 Lessee shall not make any alterations, additions, or improvements to the Leased Premises without the prior written consent of Lessor. Consent for nonstructural alterations, additions, or improvements shall not be unreasonably withheld by Lessor.

Property of Lessor

6.2 All alterations, additions, or improvements made by Lessee shall become the property of Lessor at the termination of this Lease. Lessor may, however, require that Lessee remove any or all alterations, additions, and improvements installed or made by Lessee, and any other property placed on the Premises by Lessee, upon termination of the Lease. In the event that

Lessor requires Lessee to remove such alterations, additions, or improvements, Lessee shall repair any damage to the Premises caused by such removal.

ARTICLE 7. SIGNS

Signs

7.1 Subject to the written approval of Lessor, and further subject to applicable laws, ordinances and regulations, Lessee shall have the right to install a sign on the Leased Premises. Lessee must remove all signs at the termination of this Lease and repair any damage resulting from the erection or removal of the signs.

ARTICLE 8. MECHANIC'S LIEN

8.1 Lessee will not permit any mechanic's lien or liens to be placed upon the Leased Premises or improvements on the Premises, Lessee will promptly pay the lien. If default in payment of the lien continues for twenty (20) days after written notice from Lessor Lessee, Lessor may, at its option, pay the lien or any portion of it without inquiry as to its validity. Any amounts paid by the Lessor to remove a mechanic's lien caused to be filed against the Premises or improvements on the Premises by Lessee, including expenses and interest, shall be due from Lessee to Lessor and shall be repaid to Lessor immediately on rendition of notice, together with interest at ten percent (10%) per annum until repaid.

ARTICLE 9. INSURANCE AND INDEMNITY

Property Insurance

9.1 Lessor shall, at its own expense, during the term of this Lease provide, at its own expense, during the term of this Lease, keep all buildings and improvements on the Leased Premises insured against loss or damage by fire with extended coverage to include direct loss by windstorm, hail, explosion, riot, or riot attending a strike, civil commotion, aircraft, vehicles, and

smoke, in the aggregate amounts of not less than the full fair insurable value of the buildings and improvements. The insurance is to be carried by one or more insurance companies licensed to do business in Texas and approved by Lessee. The policies shall provide that any proceeds for loss or damage to buildings or to improvements shall be payable solely to Lessor, which sum Lessor shall use for repair and restoration purposes as provided herein. Lessee shall maintain all insurance on Lessee's personal property located within the Leased Premises and Lessee covenants and agrees that Lessor shall have no responsibility for damage or destruction of Lessee's personal property located within the Leased Premises.

General Liability Insurance

9.2 Lessee, at its own expense, shall provide and maintain in force during the term of this Lease liability insurance in the amounts deemed adequate by Lessor, naming Lessor as additional insured. Prior to occupancy of the Premises, lessee shall provide Lessor with evidence of such insurance.

Remedy for Failure to Provide Insurance

9.3 Lessee shall furnish Lessor with the original of all insurance policies required by this Article. If Lessee does not provide such policies or proof of such insurance within ten (10) days of the execution of this Lease, or if Lessee allows any insurance required under this Article to lapse after receipt of notice of cancellation or of non-renewal, or if Lessee fails to deliver proof of insurance showing coverages to Lessor prior to the effective date of such insurance and the original insurance policy within thirty (30) days thereafter, such failure shall be a default of Lessee under this Lease; or Lessor may, but shall not be required to take out such insurance and pay the premiums on the necessary insurance to comply with Lessee's obligations under the provisions of this Article. Lessee agrees to reimburse Lessor all amounts spent by Lessor to procure and

maintain such insurance within fifteen (15) days after demand from Lessor. Failure to pay such amount when due shall be a default of Lessee under this Lease.

ARTICLE 10. DAMAGE OR DESTRUCTION OF PREMISES

Notice to Lessor

10.1 If the Leased Premises, or any structures or improvements on the Leased Premises, should be damaged or destroyed by fire, tornado, or other casualty, Lessee shall give immediate written notice of the damage or destruction to Lessor, including a description of the damage and, as far as known to Lessee, the cause of the damage.

ARTICLE 11. CONDEMNATION

Total Condemnation

11.1 If during the term of this Lease all of the Leased Premises should be taken for any public or quasi-public use under any governmental law, ordinance, or regulation, or by right of eminent domain, or should be sold to the condemning authority under threat of condemnation, the Lease shall terminate, and the rent shall be abated during the unexpired portion of this Lease, effective as of the date of the taking of the premises by the condemning authority.

Partial Condemnation

11.2 If less than all, but more than ten percent (10%) of the Leased Premises is taken for any public or quasi-public use under any governmental law, ordinance, or regulation, or by right of eminent domain, or should be sold to the condemning authority under threat of condemnation, Lessee may terminate the Lease by giving written notice to Lessor within thirty (30) days after possession of the condemned portion is taken by the entity exercising the power of condemnation.

If the Leased Premises are partially condemned and Lessee fails to exercise the option to terminate the Lease under this section, or if less than ten percent (10%) of the Leased Premises are condemned, this Lease shall not terminate, but Lessor may, at its sole expense, restore and

reconstruct the building and other improvements situated on the Leased Premises to make them reasonably tenantable and suitable for the uses for which the Premises are Leased. The rent payable under Sections 2.1 of this Lease shall be decreased equitably during the period of such restoration or reconstruction.

Condemnation Award

11.3 Lessor and Lessee shall each be entitled to receive and retain such separate awards, and portions of lump sum awards, as may be allocated to their respective interest in any condemnation proceedings. The termination of this Lease shall not affect the rights of the respective parties to such awards.

ARTICLE 12. DEFAULT

Default by Lessee

12.1 If Lessee shall allow the rent to be in arrears more than ten (10) days after written notice of such delinquency, or shall remain in default under any other condition of this Lease for a period of fifteen (15) days after written notice from Lessor, Lessor may at its option, without notice to Lessee, terminate this Lease or, in the alternative, Lessor may re-enter and take possession of the Premises and remove all persons and property without being deemed guilty of any manner of trespass and relet the Premises, or any part of the Premises, for all or any part of the remainder of the Lease term, to a party satisfactory to Lessor and at such monthly rental as Lessor may with reasonable diligence be able to secure. Should Lessor be unable to relet after reasonable efforts to do so, or should such monthly rental be less than the rental Lessee was obligated to pay under this Lease, or any renewal of this Lease, plus the expense of reletting, then Lessee shall pay the amount of such deficiency plus reasonable attorney's fees to Lessor.

Lessor's Lien

12.2 It is expressly agreed that, in the event of default by Lessee in the payment of rent or any other sum due from Lessee to Lessor under the terms of this Lease, Lessor shall have a lien upon all fixtures, chattels, or other property of any description belonging to Lessee that are placed in, or become a part of, the Leased Premises as security for rent due and to become due for the remainder of the current Lease term and any other sum due from Lessee to Lessor. This lien shall not be in lieu of, or in any manner affect, the statutory landlord's lien given by law but shall be in addition to that lien, and Lessee grants to Lessor a security interest in all of Lessee's property placed in or on the Leased Premises for purposes of this contractual lien. This shall not prevent the conduct of Lessee's business in the ordinary course of business and Lessee's actions in the ordinary conduct of Lessee's business shall be free of such lien to Lessor. In the event Lessor exercises the option to terminate the leasehold and re-enter and relet the Premises as provided in the preceding paragraph, then Lessor, after giving reasonable notice to Lessee of the intent to take possession and giving an opportunity for a hearing on the matter, may take possession of all of Lessee's property on the Premises and sell it at public or private sale after giving Lessee reasonable notice of the time and place of any public or private sale or of the time after that any private sale is to be made for cash or on credit, for such prices and terms as Lessor deems best, with or without having the property present at the sale. The proceeds of the sale shall be applied first to the necessary and proper expense of removing, storing and selling such property, then to repairing damage to the Leased Premises, if any, then to the payment of any rent due or to become due under this Lease, with balance, if any, to be paid to Lessee.

Default by Lessor

12.3 If Lessor defaults in the performance of any terms, covenants, or conditions required to be performed by it under this Lease, in addition to other remedies afforded Lessee under this Lease or at law, lessee may elect that:

Upon Lessee's notice to Lessor of repairs or maintenance which Lessor has a duty to undertake, Lessor neglects to make such repairs within sixty (60) days following written notice from Lessee. Lessee may vacate the Premises, in which case it shall be discharged from further payment of rent, the performance of all other terms and conditions of this Lease, and this Lease shall terminate as of the date Lessee vacates the Premises and any rental shall be abated for the unexpired term of this Lease.

Cumulative Remedies

12.4 All rights and remedies of Lessor and Lessee under this Article shall be cumulative, and none shall exclude any other right or remedy provided by law or by any other provision of this Lease. All such rights and remedies may be exercised and enforced concurrently and whenever, and as often, as occasion for their exercise arises.

Waiver of Breach

12.5 A waiver by either Lessor or Lessee of a breach of this Lease by the other party does not constitute a continuing waiver or a waiver of any subsequent breach of the Lease.

ARTICLE 13. ASSIGNMENT AND SUBLETTING

Assignment and Subletting by Lessee

13.1 Lessee may not sublet, assign, encumber, or otherwise transfer this Lease, or any right or interest in this Lease or in the Leased Premises or the improvements on the Leased Premises, without the written consent of Lessor. If Lessee sublets, assigns, encumbers, or otherwise transfers its rights or interest in this Lease or in the Leased Premises or the improvements on the Leased Premises, other than as specified herein, without the written consent of Lessor, Lessor may, at its option, declare this Lease terminated and Lessee and Lessor shall have no further obligation to each other under this Lease. In the event Lessor consents in writing to an assignment, sublease or other transfer of all or any of Lessee's rights under this Lease, the assignee or sublessee, must assume all of Lessee's obligations under this Lease, and Lessee shall

remain liable for every obligation under the Lease. Lessor's consent under this section will not be arbitrarily or unreasonably withheld.

Assignment by Lessor

13.2 Lessor may assign or transfer any or all of its interests under the terms of this Lease.

ARTICLE 14. MISCELLANEOUS

Notices and Addresses

14.1 All notices required under this Lease will be deemed delivered when deposited in certified or registered mail, addressed to the proper party, at the following addresses:

Lessor:
Ray Jones
P.O. Box 565
Mercedes, Texas 78570

Lessee:
County of Hidalgo
Attn: County Judge
100 E. Cano, 2nd Floor
Edinburg, Texas 78539

Either party may change the address to which notices are to be sent it by giving the other party notice of the new address in the manner provided in this section.

Parties Bound

14.2 This agreement shall be binding upon, and inure to the benefit of, the parties to the Lease and their respective heirs, executors, administrators, legal representatives, successors and assigns when permitted by this agreement.

Texas Law to Apply

14.3 This agreement shall be construed under, and in accordance with, the laws of the State of Texas, and all obligations of the parties created by this Lease are performable in Hidalgo County, Texas.

Legal Construction

14.4 In case any one or more of the provisions contained in this agreement shall for any reason be held by a court of competent jurisdiction to be invalid, illegal, or unenforceable in any

respect, such invalidity, illegality, or unenforceability shall not affect any other provisions of the agreement, and this agreement shall be construed as if the invalid, illegal, or unenforceable provision had never been included in the agreement.

Prior Agreements Superseded

14.5 This agreement constitutes the sole and only agreement of the parties to the agreement and supersedes any prior understandings or written or oral agreements between the parties respecting the subject matter of this agreement.

Amendment

14.6 No amendment, modification, or alteration of the terms of this agreement shall be binding unless it is in writing, dated subsequent to the date of this agreement, and duly executed by the parties to this agreement.

Rights and Remedies Cumulative

14.7 The rights and remedies provided by this lease agreement are cumulative, and the use of any one right or remedy by either party shall not preclude or waive that party's right to use any or all other remedies. The rights and remedies provided in this Lease are in addition to any other rights the parties may have by law, statute, ordinance or otherwise.

Attorneys' Fees and Costs

14.8 If, as a result of a breach of this agreement by either party, the other party employs an attorney or attorneys to enforce its rights under this Lease, then the breaching or defaulting party agrees to pay the other party the reasonable attorneys' fees and costs incurred to enforce the Lease.

Force Majeure

14.9 Neither Lessor nor Lessee shall be required to perform any term, conditions, or covenant in this Lease so long as such performance is delayed or prevented by force majeure, which shall mean acts of God, strikes, lockouts, material or labor restrictions by any governmental

authority, civil riot, floods, and any other cause not reasonably within the control of Lessor or Lessee and which by the exercise of due diligence Lessor or Lessee is unable, wholly or in part, to prevent or overcome.

Real Estate Commission and Finder's Fees

14.10 Neither Lessor nor Lessee has entered into any real estate commission or finder's fee agreements with any broker, agent or finder in respect of this transaction, and Lessor and Lessee each agree to indemnify and hold harmless the other from and against any and all claims, losses, damages, costs or expenses of any kind, or arrangement or understanding alleged to have been made by the indemnifying party or on its behalf with any broker, salesman or finder in connection with this Lease or the transactions contemplated hereby.

Estoppel Information

14.11 Lessee shall, at the request of Lessor, provide any and all information with respect to this Lease to any person designated by Lessor.

Time of Essence

14.12 Time is of the essence of this agreement.

THE UNDERSIGNED Lessor and Lessee execute this Lease on the _____ day of _____, 2016.

LESSOR:

By: _____
Ray Jones, Owner

ATTEST:

LESSEE:

Arturo Guajardo, Jr., County Clerk

Ramon Garcia, County Judge

**EXHIBIT “A”
RFB PACKET**



Hidalgo County Purchasing Department
New Administration Building
2812 S. Business Highway 281
Edinburg, Texas 78539
(956) 318-2626/ Fax: (956) 318-2629

November 23, 2015

Participant's name

Address

City

State, Zip Code

Re: HIDALGO COUNTY PRECINCT NO. 1
"LEASE OF PARCEL FOR CITIZEN COLLECTION SITE(S)-1 IN MERCEDES
AND 1 IN DONNA "
RFB No: 2016- 013-12-09-SGS

Dear Ladies/Gentlemen,

Enclosed please find a Request for Bids (RFB) packet for your review and consideration.

Hidalgo County Purchasing Department welcomes and appreciates your participation in the RFB procurement process.

If any further assistance is required, please do not hesitate to call the Purchasing Department 956/318-2626.

Sincerely,

Martha L. Salazar, CPPB
Hidalgo County Purchasing Agent

MLS/sgs

Enclosures



Hidalgo County Purchasing Department
2812 S. Business Highway 281
Edinburg, Texas 78539
(956) 318-2626/ Fax: (956) 318-2629

REQUEST FOR BIDS (RFB)
TABLE OF CONTENTS

HIDALGO COUNTY PRECINCT 1
"LEASE OF PARCEL FOR CITIZEN COLLECTION SITE(S) -1 IN MERCEDES AND
1 IN DONNA "

RFB NO: 2016-013-12-09-SGS

Item	Description	No. of Pages
1.	Request for Bid Letter	1
2.	Table of Contents	1
3.	RFB Submittal Check List	1
4.	Request for Bid, Legal Notice	8
5.	Exhibit A, Specifications/Requirements	2
6.	Exhibit B, Bid Page	1
7.	Exhibit C, Insurance Requirements,	4
8.	Exhibit D, CIQ Conflict of Interest Questionnaire	1
9.	Vendor/Bidder Application and W-9 form	6
10.	Certification Regarding Debarment	1
11.	Draft Requirements Agreement	16

The above mentioned items shall be found in the Request for Bid (RFB) packet that is attached herewith. Should you find that any of the items are not attached in its entirety please contact Purchasing by calling (956) 318-2626, advise of missing documentation, and Purchasing will forward information either through facsimile or by U.S. Mail.

Thank you.

Martha L. Salazar, CPPB, Purchasing Agent

November 23, 2015

Date



HIDALGO COUNTY

REQUEST FOR BIDS

**"LEASE OF PARCELS FOR CITIZENS COLLECTION SITES:
ONE (1) IN MERCEDES AND ONE (1) IN DONNA"**

RFB No.: 2015-013-12-09-SGS

RFB SUBMITTAL CHECK LIST

All forms listed below must be included in the RFB response, failure to submit any of these forms may be considered non responsive.

Indicate with a check mark (✓) the Forms completed and included in this Bid response:

- Page 8 of Legal Notice
- Exhibit "C" -Acknowledgement forms (pages 3 and 4)
- Exhibit "D" -CIQ Form -Copy of County Clerk File Recording fee receipt.
- Vendor Bidder Application and IRS form W-9
- Certification Regarding Debarment
- One Original, 3 Copies, of a complete copy of Bid Response/Bid Page.
- Property ID number and/or Geographical ID number
- Legal description as listed in your local Appraisal District Office.

Bid No: 2016-013-12-09-SGS

Buyer II: Sandy Suarez

Tel. No: (956) 318-2626 x 4860

REQUEST FOR BIDS

HIDALGO COUNTY (PRECINCT No. 1)

**“LEASE OF PARCELS FOR CITIZENS COLLECTION SITE(S):
ONE (1) IN MERCEDES AND ONE (1) IN DONNA”**

Contact Person:

Martha L. Salazar, CPPB, Purchasing Agent
Hidalgo County Purchasing Department
2812 S. Business Hwy 281 – New Administration Building
Edinburg, Texas 78539

956 318-2626

Form HCPD-03

1. Sealed bids will be received for **HIDALGO COUNTY PRECINCT NO. 1 – “LEASE OF PARCEL FOR CITIZEN COLLECTION SITE(S): ONE (1) IN MERCEDES AND ONE (1) IN DONNA”** in accordance with the specifications attached as Exhibit "A" hereto. Bids should address all specifications set forth. Bidders may suggest substitutions of features which they feel would be in the best interest of Hidalgo County ("County"). Strong rationale must be presented for any deviation from the specifications. Hidalgo County reserves the right to reject the deviation and its effect on the overall bid.
2. One (1) original and Three (3) copies of all bids are required with the bidders name and return address clearly typed/printed on upper left hand corner and the proper notation clearly typed/printed on the lower left hand corner of the envelope and/or package: **BID-2016-013-12-09-SGS - HIDALGO COUNTY PRECINCT NO. 1 – “LEASE OF PARCEL FOR CITIZEN COLLECTION SITE(S): ONE (1) IN MERCEDES AND ONE (1) IN DONNA”** and in County's Purchasing Department, 2812 S. Business 281, New Administration Building, Edinburg, Texas, on or before 9:30 a.m., **WEDNESDAY, DECEMBER 09, 2015**. **NO FACSIMILES OR LATE ARRIVALS WILL BE ACCEPTED. ANY RFB RECEIVED AFTER THAT TIME WILL NOT BE OPENED AND WILL BE RETURNED. OVERNIGHT MAIL MUST ALSO BE PROPERLY LABELED ON THE OUTSIDE OF EXPRESS ENVELOPE OR PACKAGE WITH REFERENCE TO REQUEST FOR BIDS-2016-013-12-09-SGS- HIDALGO COUNTY PRECINCT NO. 1 – “LEASE OF PARCEL FOR CITIZEN COLLECTION SITE(S): ONE (1) IN MERCEDES AND ONE (1) IN DONNA”**. Hidalgo County reserves the right to refuse and reject any/all RFB and to waive any/all formalities or technicalities, or to accept the RFB considered the best and most advantageous to Hidalgo County.
3. Hidalgo County reserves the right to: A. separate and accept, or eliminate any item(s) listed under this bid that it deems necessary to accommodate budgetary and/or operational requirements; B. reject any or all bids submitted and further reserves the right to design the evaluation criteria to be used in selecting the lowest and best bid for approval; and C. award the bid to one bidder or to multiple bidders if the County determines it is in its best interest to do so.”
4. The Bidder shall not substitute items named in the bid without the express written consent of Hidalgo County. Failure of the delivered item(s) to perform as specified or failure to meet the stated delivery schedule shall release Hidalgo County from all obligations to the contracting party with regard to the item(s) in question. In such event, County may elect to award the contract to the next-lowest responsible bidder, or to reject all bids and re-advertise.
5. For work to be performed at a County owned or operated location, each bidder shall, in its sole discretion, visit the job site before preparing the bid and thoroughly familiarize himself/herself with existing conditions. Bidder should take field dimensions and note all circumstances which affect the dollar amount of the bid.
6. Descriptive specifications are referenced in this document to indicate the general kind and quality of equipment desired by Hidalgo County. Due to various styles and models of equipment, bidders are required to include illustrations, specifications, explanation of warranties, and service data with their bid including catalogue numbers and any necessary references.

7. No bid may be withdrawn within thirty (30) days from the scheduled time to open bids.
8. Proposed prices are to remain firm for a minimum of ninety (90) days after bid opening.
9. Any interpretations, amendments, corrections or changes to this bid document must be in a written addendum and signed by the County Judge or his designee. Addenda will be mailed to all who are known to have received a copy of the Request for Bids. Bidders shall acknowledge receipt of all addenda as a part of their bid.
10. County reserves the right to accept or reject any or all bids.
11. Costs are to be net F.O.B., County Prepaid.
12. County is exempt from Federal Excise Tax, State Tax and Local Tax. Do Not include tax in cost figure. If it is determined that tax was included in the cost figures it will not be included in the tabulation of any awards. Tax exemption certificates will be furnished upon request.
13. Funds for this procurement have been provided through the County budget for this fiscal year only. County, on an annual basis, has the right to reconsider a contract during the budget process for ensuing years if financial resources of County are insufficient to meet the liabilities of said contract. The award of a bid or contract hereunder will not be construed to create a debt of the County which is payable out of funds beyond the current fiscal year.
14. Upon award and prior to execution of a contract, Sole Proprietorships are required to submit a copy of their social security cards to the Hidalgo County Auditor's Office in order to establish an account with the County. All awarded vendors must submit a completed W-9 and a copy of their Federal ID Number Certificate.
15. DELIVERY INSTRUCTIONS: (IF APPLICABLE)

- . No deliveries accepted after 3:00 P.M., Monday-Friday.
- . At least seventy two (72) hours prior notice of delivery must be given to Martha L. Salazar, Purchasing Agent before delivery will be accepted.
- . If you need additional information call the office listed below:

Hidalgo County Purchasing Department
Martha L. Salazar, Purchasing Agent
(956) 318-2626

16. BILLING AND PAYMENT INSTRUCTIONS:

- . Invoices must include:
 - a) Name and address of successful bidder
 - b) Name and address of receiving department or official
 - c) Purchase Order Number or Contract Number (if any)
 - d) Notation - **HIDALGO COUNTY PRECINCT NO. 1 - "LEASE OF**

PARCEL FOR CITIZEN COLLECTION SITE(S): ONE (1) IN MERCEDES AND ONE (1) IN DONNA". Descriptive information as to the items or services delivered, including product code, item number, quantity, etc.

- Discount payments will be considered when offered.
- Contact person for Billing and Payment questions:

Hidalgo County Precinct No. 1
Attn: Katia Garcia
1902 Joe Stephens Ave.
Weslaco, TX 78596
956-968-8733

17. Schedule of Events

Bid Opening, 9:30 AM	<u>DECEMBER 09, 2015</u>
Award of Contract	_____, 2015
Commence Work or Deliver Products	_____, 2015

18. Bid or Performance Bond and Debarment Certification; Payment Under Contract:

If the contract proposed is for the construction of public works or is for a contract for goods & services exceeding \$100,000, all bidders shall furnish a good and sufficient bid bond in the amount of five percent of the total contract price. A bid bond must be executed with a surety company authorized to do business in Texas. All bidders are also required to furnish a certification or acknowledgment stating that the contractor or vendor is free from suspension or debarment pursuant to federal regulation 45CFR Part 76.

Together with the signing of a contract or issuance of a purchase order following the acceptance of a bid, and prior to commencement of the actual work, the bidder shall furnish a performance bond to the County for the full amount of the contract, if that contract exceeds \$50,000.

If the contract is for \$50,000 or less, no money will be paid to the contractor until completion and acceptance of the work or the fulfillment of the purchase obligation to the County, and, if applicable, the receipt by County of satisfactory evidence that all subcontractors and material men have been paid.

If a contract is for the construction, alteration or repair of public buildings or public works, the contractor *shall* provide a payment bond for a contract in excess of Twenty Five Thousand Dollars (\$25,000.00), as required by Tex. Govt. Code Ch. 2253.

For requirements contracts, bond requirements are determined by applying the proposed unit price to the estimated quantities included in the specifications.

19. Ethical Standards:

. It shall be a breach of ethics to offer, give or agree to give any elected official, department head or employee, or former elected official, department head or employee, of the County, or for any elected official, department head or employee or former elected official, department head or employee of the County, to solicit, demand, accept or agree to accept from another person, entity or organization, a gratuity or an offer of employment in connection with any decision, approval, disapproval, recommendation, preparation or any part of a program requirement or purchase request, influencing the content of any specification or procurement standard, rendering of advice, investigation, auditing, or in any other advisory capacity in any proceeding or application, request for ruling, determination, claim or controversy, or other particular matter pertaining to any program requirement or a contract or subcontract, or to any solicitation or proposal therefore pending before any department or agency of the County.

. It shall be a breach of ethics for any payment, gratuity or offer of employment to be made by or on behalf of a subcontractor under a contract to the prime contractor or higher tier subcontractor for any contract for the County, or any person associated therewith, as an inducement for the award of a subcontract or order.

. No public official shall have an interest in a contract awarded hereunder except in accordance with Tex. Loc. Govt. Code Chapter 171.

20. Disclosure of Conflict of Interest

. Effective January 1, 2006, Chapter 176 of the Texas Local Government Code requires that any vendor, person, consultant or contractor considering doing business with Hidalgo County ("the County") to disclose in the Conflict of Interest Questionnaire (the "CIQ") attached as Exhibit D, the vendor, person, consultant or contractor's affiliation or business relationship that might cause a conflict of interest with the County. By law, the CIQ must be filed with the Hidalgo County Clerk's Office no later than the seventh business day after the date the person becomes aware of facts that require that statement to be filed. The disclosure requirement applies to a person or business who contracts or seeks to contract with Hidalgo County for the sale or purchase of property, goods or service. Any purchase order or contract resulting from this process shall be considered null and void if the successful bidder fails to comply with Texas Local Government Code Chapter 176. Vendors, consultants, contractors and others who desire to conduct business with Hidalgo County are encouraged to refer to Texas Local Government Code Chapter 176 for the details of this law. An offense under Texas Local Government Code Chapter 176 is a Class C Misdemeanor.

Please Submit completed CIQ forms to the Hidalgo County Clerk's Office located at 100 N. Clossner, Edinburg, Texas 78539-Hidalgo County Courthouse.

COMPLETION AND SUBMISSION OF FORM CIQ IS THE SOLE RESPONSIBILITY OF THE PROSPECTIVE BIDDER.

21. If, during the life of any contract or bid awarded, the successful bidder's net prices generally available to other customers for items awarded herein are reduced below the contracted price, it is understood and agreed that the benefits of such reduction shall be extended to County.
22. Bids, and all goods and services provided thereunder, shall comply with all federal, state and local laws concerning this type(s) of goods and/or services.
23. Minimum Standards For Responsible Prospective Bidders: A prospective bidder must affirmatively demonstrate bidder's responsibility. A prospective bidder, by submitting a bid, represents to County that it meets the following requirements:
 - . Possess or is able to obtain adequate financial resources as required to perform under the bid;
 - . Be able to comply with the required or proposed delivery schedule;
 - . Have a satisfactory record of performance;
 - . Have a satisfactory record of integrity and ethics;
 - . Be otherwise qualified and eligible to receive an award.
24. Successful bidder will pay or cause to be paid, without cost or expenses to County, all FICA, FUTA/SUTA and Federal Income Withholding Taxes of all employees, and all wages and benefits as required by Federal or State law. Successful bidder's officers, agents and/or employees will not be entitled to any benefits of an employee or elected official of County, including, but not limited to, benefits associated with County's civil service system.
25. Any contract award to a successful bidder will be in effect until (a) the contract expires, (b) delivery and acceptance of products, and/or performance of services ordered, or (c) terminated by County with thirty day's written notice prior to cancellation.
26. County reserves the right to enforce performance of any contract awarded hereunder in any manner prescribed by law or deemed to be in the best interest of the County in the event of breach or default by successful bidder; County reserves the right to terminate any contract immediately in the event a successful bidder fails to:
 - A. Meet schedules;
 - B. Pay any required fees or taxes; or
 - C. Otherwise perform in accordance with the specifications.
27. Successful bidder shall defend, indemnify and save harmless County and all its elected officials, officers, agents and employees from all suits, actions, or other claims of any character, name and description brought for or on account of any injuries or damages received or sustained by any person, persons, or property on account of any negligent act or fault of the successful bidder, or of any agent, employee, subcontractor or supplier of successful bidder in the execution of, or performance under, any contract which may result from bid award or which arises from any event or casualty happening on or within County premises themselves or happening upon or in any halls, elevators, entrances, stairways or approaches of or to such County facilities. Successful bidder shall pay any judgment with costs which may be obtained against County growing out of such injury or

damages, and shall, upon request, provide a defense to County by counsel reasonably acceptable to County. Successful bidder's indemnity hereunder shall include, but is not limited to, claims relating to patent, copyright or trademark infringement, and the like, arising out of the goods and services provided by successful bidder.

28. Successful bidder shall warrant that all items/services shall conform with the specifications and/or all warranties provided under the Uniform Commercial Code and be free from all defects in material, workmanship and the like. Items supplied under a contract pursuant to this Request for Bids shall be subject to County's approval. Items found to be defective or not meeting specifications shall be replaced by successful bidder within two business days at no expense to County. Items not picked up within one (1) week after notification shall be deemed a donation to County and may be used or disposed of at County's discretion and without waiver of any other rights of County as to the item's nonconformity.
29. This document and any disputes arising hereunder shall be governed and construed according to the laws of the State of Texas, and will be performable exclusively in Hidalgo County, Texas.
30. The successful bidder shall not assign, sell, transfer or convey its rights under any awarded contract, in whole or in part, without the prior written consent of County.

Bid
for
**HIDALGO COUNTY
PRECINCT NO. 1**
"LEASE OF PARCEL FOR CITIZEN COLLECTION SITE(S): ONE (1) IN
MERCEDAS AND ONE (1) IN DONNA"

BID NO.: 2016-013-12-09-SGS

To: Martha L. Salazar, CPPB, Purchasing Agent
Hidalgo County Purchasing Department
2812 S. Business Hwy 281-New Administration Bldg.
Edinburg, Texas 78539

In accordance with the Specifications, and subject to all laws and regulations of the United States and state and local laws, the undersigned bidder proposes and commits to furnish all labor, equipment, material, software and services as set forth in the documents hereinbefore mentioned. The undersigned bidder further agrees, upon acceptance of its bid, to execute a contract and/or Purchase Order issued by Hidalgo County for performing and completing the work described in the Specifications within the time stated and for the prices proposed in the documents attached hereto and made a part hereof.

Bidder acknowledges receipt of all of the pages of the documents referenced in the Invitation to Bid Checklist presented in connection with this procurement. Bidder understands that Hidalgo County reserves the right to reject any or all bids and further reserves the right to design the evaluation criteria to be used in selecting the lowest and best bid.

Bidder agrees that this bid shall be good and may not be withdrawn for a period of ninety (90) calendar days after the scheduled closing time for receiving bids, as contained in the Specifications.

Respectfully submitted,

Bidder: _____
Address: _____
By: _____
Printed Name: _____
Title: _____

EXHIBIT "A"
HIDALGO COUNTY PRECINCT NO. 1
"LEASE OF PARCEL FOR CITIZEN COLLECTION SITE(S) 1 IN MERCEDES AND 1 IN
DONNA"
RFB NO.: 2016-013-12-09-SGS

SCOPE OF SERVICES:

The County Of Hidalgo is accepting sealed bids to lease two parcels of land for Hidalgo County Precinct NO. 1 for the purpose of establishing citizen collections site(s); One (1) in Mercedes and One (1) in Donna including, but not limited to the following:

SPECIFICATIONS

1. Property Locations within the areas of:
 - a. South of FM 493 and Mile West, Donna, Texas
 - b. One (1) Mile South of Business 83 on Mile 1 East, Mercedes, Texas
2. Lease must be on a monthly basis.
3. Owner must submit copy of property insurance.

REQUIREMENTS, TERMS AND CONDITIONS

1. One (1) or more vendor(s) may be designated as awarded Vendor(s) for Lease of Parcel for Citizen Collection Site(s): One (1) in Mercedes and One (1) in Donna for Hidalgo County Precinct No 1.
2. Hidalgo County is requesting that all interested vendor(s) submitting bids for the project, **must provide the following:**
 - a. Property ID number and/or Geographical ID number;
 - b. Legal description as listed in your local Hidalgo County Appraisal District for proposed property;
3. Hidalgo County reserves the right to award to multiple vendors if the County determines it is in its best interest to do so.
4. Hidalgo County reserves the right to reject any/all bids, to waive any/all formalities¹¹ or technicalities or to accept the bid considered the best and most advantage to the County.
5. Hidalgo County reserves the right to continue this bid for an additional sixty (60) days grace period at the end of the contract term due to any unforeseen delay in the procurement process.
6. Hidalgo County reserves the right to hold bids for a period of ninety (90) days without

EXHIBIT "A"
HIDALGO COUNTY PRECINCT NO. 1
"LEASE OF PARCEL FOR CITIZEN COLLECTION SITE(S) 1 IN MERCEDES AND 1 IN
DONNA"
RFB NO.: 2016-013-12-09-SGS

taking any action.

7. Property insurance policy shall provide that any proceeds for loss or damage to building or to improvements shall be payable solely to Lessor, which sum shall be used by Lessor's for repair and restoration purpose.
8. Vendor must submit and maintain all proper insurances for the duration of contract term. (refer to EXHIBIT C).
9. Any contract awarded to a successful bidder will be in effect until;
 - a) The contract expires
 - b) Delivery acceptance of products and/or performance of services ordered, or
 - c) Terminated by County with thirty (30) days written notice prior to be cancellation.
10. **All cost and expenses associated with the preparation and submission of (bids, proposals, statements of qualifications (RFQ) and quotes) shall be the responsibility of the bidder and no reimbursements for such charges or expenses shall be passed onto Hidalgo County.**

TERM: The term of the bid contract will be for a period of one (1) year. Hidalgo County may in its sole discretion elect the option to extend the contract for two (2) additional one (1) year under the same rates, terms and conditions.

ADDITIONAL INFORMATION:

Hidalgo County is requesting that any and all questions, inquires and clarifications regarding quotes, bids, proposals or statements of qualifications be addressed to Martha L. Salazar, CPPB, Purchasing Agent, 2812 South Business Hwy. 281, Edinburg, Tx 78539

ALL WRITTEN INQUIRIES WILL BE ACCEPTED VIA FACSIMILE (956) 292-7612 OR VIA EMAIL to: sandy.suarez@co.hidalgo.tx.us , NO LATER THAN Wednesday, December 02, 2015 by 5:00 P.M. Responses to said inquiries will be sent to all applicants via facsimile or via email by no later than Friday, December 04, 2015 by 5:00 p.m.

EXHIBIT "B"
HIDALGO COUNTY PRECINCT NO 1
"LEASE PARCEL FOR CITITZEN COLLECTION SITE(S) -1 IN MERCEDES AND 1
IN DONNA"
RFB NO.: 2015-013-12-09-SGS

Monthly Premium

The following fees are on a monthly basis only:

Location A: South of FM 493 and Mlle West, Donna, Texas \$

Location B: 1- Mile South of Business 83 on Mile 1 East,
Mercedes, Texas \$

> **Location A:**
Property ID and/or
Geographical ID: _____
Legal Description of Property: _____

> **Location B:**
Property ID and/or
Geographical ID: _____
Legal Description of Property: _____

(NIGP CODE: 971-35)

BIDDER'S INFORMATION:

F
G
M
-
P
G

BIDDER/COMPANY NAME: _____
ADDRESS: _____
CITY/STATE/ZIP CODE: _____
PHONE & FAX NO'S: _____
CELLULAR No. _____
EMAIL ADDRESS: _____
AUTHORIZED SIGNATURE: _____
PRINTED NAME: _____
TITLE _____

EXHIBIT "C"

Insurance Requirements

The Bidder awarded the contract shall furnish proof of insurance, which will also include any subcontractor that is subcontracted by the bidder in at least the following limits, to be in place prior to providing any services under this Contract and to continue at all times in force in effect during the term of this Contract:

1. A Five Hundred Thousand Dollar (\$500,000.00) Comprehensive General Liability insurance policy providing additional coverage to all underlying liabilities of County.
2. Automobile liability insurance policy with limits of at least Three Hundred Thousand Dollars (\$300,000.00) per person and Five Hundred Thousand Dollars (\$500,000.00) per occurrence. Coverage should include injury to or death of persons and property damage claims with limits up to Five Hundred Thousand (\$500,000.00) arising out of the services provided to County hereunder.
3. Uninsured/Underinsured motorist coverage in an amount equal to the bodily injury limits set forth immediately above;
4. Workers compensation insurance in amounts established by Texas law, unless the Bidder is specifically exempted from the Texas Workers Compensation Act, Texas Labor Code Chapter 401, et. seq.

Hidalgo County will only accept certificates of insurance on an Acord form (as attached hereto). Certificates of insurance shall name Hidalgo County as additional insured and must be submitted to County for approval prior to any services being performed by Contractor. Each policy of insurance required hereunder shall extend for a period equivalent to, or longer than the term of the Contract, and any insurer hereunder shall be required to give at least thirty (30) days written notice to the County prior to the cancellation of any such coverage on the termination date, or otherwise. This Contract shall be automatically suspended upon the cancellation, or other termination, of any required policy of insurance hereunder, and such suspension shall continue until evidence adequate replacement coverage is provided to County. If replacement coverage is not provided within thirty (30) days following suspension of the Contract, this Contract shall automatically terminate.

Revised 10/01/08

ACORD**CERTIFICATE OF INSURANCE**

DATE (MM/DD/YY)

PRODUCER

THIS CERTIFICATE IS ISSUED AS A MATTER OF INFORMATION ONLY AND CONFERS NO RIGHTS UPON THE CERTIFICATE HOLDER. THIS CERTIFICATE DOES NOT AMEND, EXTEND OR ALTER THE COVERAGE AFFORDED BY THE POLICIES BELOW.

INSURERS AFFORDING COVERAGE

INSURED

INSURER A:

INSURER B:

INSURER C:

INSURER D:

INSURER E:

COVERAGES

THE POLICIES OF INSURANCE LISTED BELOW HAVE BEEN ISSUED TO THE INSURED NAMED ABOVE FOR THE POLICY PERIOD INDICATED NOTWITHSTANDING ANY REQUIREMENT, TERM OR CONDITION OF ANY CONTRACT OR OTHER DOCUMENT WITH RESPECT TO WHICH THIS CERTIFICATE MAY BE ISSUED OR MAY PERTAIN. THE INSURANCE AFFORDED BY THE POLICIES DESCRIBED HEREIN IS SUBJECT TO ALL THEIR TERMS, EXCLUSIONS AND CONDITIONS OF SUCH POLICIES. AGGREGATE LIMITS SHOWN MAY HAVE BEEN REDUCED BY PAID CLAIMS.

INSR LTR	TYPE OF INSURANCE	POLICY NUMBER	POLICY EFFECTIVE DATE (MM/DD/YY)	POLICY EXPIRATION DATE (MM/DD/YY)	LIMITS
A	GENERAL LIABILITY				EACH OCCURRENCE \$
	<input type="checkbox"/> COMMERCIAL GENERAL LIABILITY				FIRE DAMAGE (Any one fire) \$
	<input type="checkbox"/> CLAIMS MADE OCCUR				MEDICAL (Any one person) \$
	<input type="checkbox"/> OWNER'S & CONT. PROT				PERSONAL & ADV INJURY \$
	<input type="checkbox"/> OWNER'S PROTECTIVE LIABILITY				ANNUAL AGGREGATE \$
	<input type="checkbox"/> GEN'L AGGREGATE LIMIT APPLIES PER POLICY PROJECT <input type="checkbox"/> LOC				PRODUCTS -- COMP/OP AGG \$
B	AUTOMOBILE LIABILITY				COMBINED SINGLE LIMIT (Each auto) \$
	<input type="checkbox"/> ANY AUTO				BODILY INJURY (Per person) \$
	<input type="checkbox"/> ALL OWNED AUTOS				BODILY INJURY (Per accident) \$
	<input type="checkbox"/> SCHEDULED AUTOS				PROPERTY DAMAGE (Per accident) \$
	<input type="checkbox"/> HIRED AUTOS				AUTO ONLY- EA ACCIDENT \$
<input type="checkbox"/> NON OWNED AUTOS				OTHER THAN AUTO ONLY EA ACC AGG \$	
C	GARAGE LIABILITY				\$
	<input type="checkbox"/> ANY AUTO				AGGREGATE \$
	<input type="checkbox"/> OCCUR <input type="checkbox"/> CLAIMS MADE				\$
	<input type="checkbox"/> DEDUCTIBLE				\$
D	EXCESS LIABILITY				\$
	<input type="checkbox"/> RETENTION \$				\$
	WORKERS COMPENSATION AND EMPLOYER'S LIABILITY				WC STATU: <input type="checkbox"/> OTHER TORY LIMITS
					E. L. EACH ACCIDENT \$
				E. L. DISEASE- EA EMPLOYEE \$	
	OTHER			E. L. DISEASE- POLICY LIMIT \$	

DESCRIPTION OF OPERATIONS / LOCATION / VEHICLES / EXCLUSIONS ADDED BY ENDORSEMENT / SPECIAL PROVISIONS
County of Hidalgo shall be named as additional insured on all Commercial General Liability policies.

CERTIFICATE HOLDER

ADDITIONAL INSURED; INSURER LETTER:

CANCELLATION

Hidalgo County
Attn: Purchasing Department
2812 S Highway Bus. 281
Edinburg, Texas 78539SHOULD ANY OF THE ABOVE DESCRIBED POLICIES BE CANCELLED BEFORE THE EXPIRATION DATE THEREOF, THE ISSUING INSURER WILL ENDEAVOR TO MAIL 30 DAYS WRITTEN NOTICE TO THE CERTIFICATE HOLDER NAMED TO THE LEFT, BUT FAILURE TO DO SO SHALL IMPOSE NO OBLIGATION OR LIABILITY OF ANY KIND UPON THE INSURER, ITS AGENTS OR REPRESENTATIVES
AUTHORIZED REPRESENTATIVE

Insurance Requirement Acknowledgment

I, _____, authorized representative for _____,
Company/Vendor

hereby acknowledge receipt of the County's required insurance limits. Said requirements:

- will be acquired within 10 working days after notification from Purchasing Department of bid awarded by the Hidalgo County Commissioner's Court;
- will acquire additional amounts required to meet the County's requirements within 10 working days after notification from Purchasing Department of bid award by the Hidalgo County Commissioner's Court; currently carry the following:

Automobile Liability: \$ _____ General Liability: \$ _____

- have already been met; see attached copy of insurance certificate.

Authorized Representative

Date

Notice to Bidder:

A certificate of insurance for the required insurance limits shall be provided to the Purchasing Department's Contract Managers in order to qualify for award of bid and to execute a contract between your Company and the County

Failure to provide Certificates of Insurance to the Purchasing Department's Contract Managers will cause the bid award to be rescinded and re-awarded to next lowest bidder. Certificates of Insurance will be monitored and verified on a **quarterly basis** to ensure coverage policy is in place. It is the Company's obligation to maintain the appropriate insurance coverage throughout the term of the contract.

THIS FORM MUST ACCOMPANY BID PACKET

PROJECT REQUIREMENTS ACKNOWLEDGMENT

This is to certify that I, _____, possess all of the APPLICABLE:

1. Licenses: _____.

2. Bonds: _____.

3. Certificates: _____.

4. Permits: _____.

5. Other: _____.

Necessary to carry out the required project. Furthermore, I am providing copies of the required documentation so that, if my company is awarded this bid, I may be eligible to enter into a contract with Hidalgo County and proceed to complete the project in a timely manner.

* Any licenses, bonds, certificates, permits, etc. which are required must be presented as part of the bid packet in order to expedite the bid evaluation process. Failure to provide said documentation will result in the disqualification of your bid.

Authorized Signature

Date

Company

Address

City, State, Zip

EXHIBIT "D"

CONFLICT OF INTEREST QUESTIONNAIRE

FORM CIQ

For vendor or other person doing business with local governmental entity

This questionnaire reflects changes made to the law by H.B. 1491, 80th Leg., Regular Session.

This questionnaire is being filed in accordance with Chapter 176, Local Government Code by a person who has a business relationship as defined by Section 176.001(1-a) with a local governmental entity and the person meets requirements under Section 176.006(a).

By law this questionnaire must be filed with the records administrator of the local governmental entity not later than the 7th business day after the date the person becomes aware of facts that require the statement to be filed. See Section 176.006, Local Government Code.

A person commits an offense if the person knowingly violates Section 176.006, Local Government Code. An offense under this section is a Class C misdemeanor.

OFFICE USE ONLY

Date Received

1 Name of person who has a business relationship with local governmental entity.

2 Check this box if you are filing an update to a previously filed questionnaire.

(The law requires that you file an updated completed questionnaire with the appropriate filing authority not later than the 7th business day after the date the originally filed questionnaire becomes incomplete or inaccurate.)

3 Name of local government officer with whom filer has employment or business relationship.

Name of Officer

This section (item 3 including subparts A, B, C & D) must be completed for each officer with whom the filer has an employment or other business relationship as defined by Section 176.001(1-a), Local Government Code. Attach additional pages to this Form CIQ as necessary.

A. Is the local government officer named in this section receiving or likely to receive taxable income, other than investment income, from the filer of the questionnaire?

Yes No

B. Is the filer of the questionnaire receiving or likely to receive taxable income, other than investment income, from or at the direction of the local government officer named in this section AND the taxable income is not received from the local governmental entity?

Yes No

C. Is the filer of this questionnaire employed by a corporation or other business entity with respect to which the local government officer serves as an officer or director, or holds an ownership of 10 percent or more?

Yes No

D. Describe each employment or business relationship with the local government officer named in this section.

4

Signature of person doing business with the governmental entity

Date

HISTORICALLY UNDERUTILIZED BUSINESS (HUB) DECLARATION

The primary objective of the Hidalgo County HUB Program is to ensure Historically Underutilized Businesses receive a fair and equal opportunity for participation in the County's procurement process. This fact holds true for Services (Professional & Non-Professional), Commodities, and Construction contracts and any subcontracts thereto. The program strongly encourages Prime Contractors to provide subcontracting opportunities to Certified Hub Contractors/Vendors. Our goal for HUB contractor/vendor participation, as well as HUB subcontractor participation is 30%. To be considered as a "Certified HUB Contractor/Vendor" the contractor/vendor must have been certified by, and hold a current and valid certification with any of the three agencies listed below.

Have you been Certified as a HUB or an MBE/WBE source?: Yes No

If yes, by whom?: Texas Building & Procurement Commission Other _____

Indicate Certification No(s): _____ or Are Certificate(s) Attached?: Yes No

LIST OF CERTIFIED HUB SUBCONTRACTORS

(Attach additional pages if necessary)

What percentage of the Bid, RFP, or RFQ is to be subcontracted with Certified HUB sources?: _____% (List HUB Subcontractor information below).

HUB Subcontractor Name: _____ HUB Status: _____
Certifying Agency (Check all applicable): Texas Building & Procurement Commission Other
Address: _____ City: _____ State: _____ Zip: _____
Contact Person: _____ Title: _____ Phone No.: () _____
Subcontract Amount: \$ _____ Description of Work to be Performed: _____

HUB Subcontractor Name: _____ HUB Status: _____
Certifying Agency (Check all applicable): Texas Building & Procurement Commission Other
Address: _____ City: _____ State: _____ Zip: _____
Contact Person: _____ Title: _____ Phone No.: () _____
Subcontract Amount: \$ _____ Description of Work to be Performed: _____

HUB Subcontractor Name: _____ HUB Status: _____
Certifying Agency (Check all applicable): Texas Building & Procurement Commission Other
Address: _____ City: _____ State: _____ Zip: _____
Contact Person: _____ Title: _____ Phone No.: () _____
Subcontract Amount: \$ _____ Description of Work to be Performed: _____

Request for Taxpayer Identification Number and Certification

Give Form to the
requester. Do not
send to the IRS.

Print or type
See Specific Instructions on page 2.

Name (as shown on your income tax return)	
Business name/disregarded entity name, if different from above	
Check appropriate box for federal tax classification: <input type="checkbox"/> Individual/sole proprietor <input type="checkbox"/> C Corporation <input type="checkbox"/> S Corporation <input type="checkbox"/> Partnership <input type="checkbox"/> Trust/estate <input type="checkbox"/> Limited liability company. Enter the tax classification (C=C corporation, S=S corporation, P=partnership) ▶ _____ <input type="checkbox"/> Other (see instructions) ▶ _____	Exemptions (see Instructions): Exempt payee code (if any) _____ Exemption from FATCA reporting code (if any) _____
Address (number, street, and apt. or suite no.)	Requester's name and address (optional)
City, state, and ZIP code	
List account number(s) here (optional)	

Part I Taxpayer Identification Number (TIN)

Enter your TIN in the appropriate box. The TIN provided must match the name given on the "Name" line to avoid backup withholding. For individuals, this is your social security number (SSN). However, for a resident alien, sole proprietor, or disregarded entity, see the Part I Instructions on page 3. For other entities, it is your employer identification number (EIN). If you do not have a number, see *How to get a TIN* on page 3.

Note. If the account is in more than one name, see the chart on page 4 for guidelines on whose number to enter.

Social security number		
[] [] [] - [] [] - [] [] [] []		

Employer identification number		
[] [] [] [] - [] [] [] [] [] [] [] []		

Part II Certification

Under penalties of perjury, I certify that:

1. The number shown on this form is my correct taxpayer identification number (or I am waiting for a number to be issued to me), and
2. I am not subject to backup withholding because: (a) I am exempt from backup withholding, or (b) I have not been notified by the Internal Revenue Service (IRS) that I am subject to backup withholding as a result of a failure to report all interest or dividends, or (c) the IRS has notified me that I am no longer subject to backup withholding, and
3. I am a U.S. citizen or other U.S. person (defined below), and
4. The FATCA code(s) entered on this form (if any) indicating that I am exempt from FATCA reporting is correct.

Certification instructions. You must cross out Item 2 above if you have been notified by the IRS that you are currently subject to backup withholding because you have failed to report all interest and dividends on your tax return. For real estate transactions, Item 2 does not apply. For mortgage interest paid, acquisition or abandonment of secured property, cancellation of debt, contributions to an individual retirement arrangement (IRA), and generally, payments other than interest and dividends, you are not required to sign the certification, but you must provide your correct TIN. See the Instructions on page 3.

Sign Here	Signature of U.S. person ▶	Date ▶
------------------	----------------------------	--------

General Instructions

Section references are to the Internal Revenue Code unless otherwise noted.

Future developments. The IRS has created a page on www.irs.gov/w9 for information about Form W-9, at www.irs.gov/w9. Information about any future developments affecting Form W-9 (such as legislation enacted after we release it) will be posted on that page.

Purpose of Form

A person who is required to file an information return with the IRS must obtain your correct taxpayer identification number (TIN) to report, for example, income paid to you, payments made to you in settlement of payment card and third party network transactions, real estate transactions, mortgage interest you paid, acquisition or abandonment of secured property, cancellation of debt, or contributions you made to an IRA.

Use Form W-9 only if you are a U.S. person (including a resident alien), to provide your correct TIN to the person requesting it (the requester) and, when applicable, to:

1. Certify that the TIN you are giving is correct (or you are waiting for a number to be issued),
2. Certify that you are not subject to backup withholding, or
3. Claim exemption from backup withholding if you are a U.S. exempt payee. If applicable, you are also certifying that as a U.S. person, your allocable share of any partnership income from a U.S. trade or business is not subject to the

withholding tax on foreign partners' share of effectively connected income, and

4. Certify that FATCA code(s) entered on this form (if any) indicating that you are exempt from the FATCA reporting, is correct.

Note. If you are a U.S. person and a requester gives you a form other than Form W-9 to request your TIN, you must use the requester's form if it is substantially similar to this Form W-9.

Definition of a U.S. person. For federal tax purposes, you are considered a U.S. person if you are:

- An individual who is a U.S. citizen or U.S. resident alien,
- A partnership, corporation, company, or association created or organized in the United States or under the laws of the United States,
- An estate (other than a foreign estate), or
- A domestic trust (as defined in Regulations section 301.7701-7).

Special rules for partnerships. Partnerships that conduct a trade or business in the United States are generally required to pay a withholding tax under section 1446 on any foreign partners' share of effectively connected taxable income from such business. Further, in certain cases where a Form W-9 has not been received, the rules under section 1448 require a partnership to presume that a partner is a foreign person, and pay the section 1446 withholding tax. Therefore, if you are a U.S. person that is a partner in a partnership conducting a trade or business in the United States, provide Form W-9 to the partnership to establish your U.S. status and avoid section 1446 withholding on your share of partnership income.

In the cases below, the following person must give Form W-9 to the partnership for purposes of establishing its U.S. status and avoiding withholding on its allocable share of net income from the partnership conducting a trade or business in the United States:

- In the case of a disregarded entity with a U.S. owner, the U.S. owner of the disregarded entity and not the entity,
- In the case of a grantor trust with a U.S. grantor or other U.S. owner, generally, the U.S. grantor or other U.S. owner of the grantor trust and not the trust, and
- In the case of a U.S. trust (other than a grantor trust), the U.S. trust (other than a grantor trust) and not the beneficiaries of the trust.

Foreign person. If you are a foreign person or the U.S. branch of a foreign bank that has elected to be treated as a U.S. person, do not use Form W-9. Instead, use the appropriate Form W-8 or Form 8233 (see Publication 515, Withholding of Tax on Nonresident Aliens and Foreign Entities).

Nonresident alien who becomes a resident alien. Generally, only a nonresident alien individual may use the terms of a tax treaty to reduce or eliminate U.S. tax on certain types of income. However, most tax treaties contain a provision known as a "saving clause." Exceptions specified in the saving clause may permit an exemption from tax to continue for certain types of income even after the payee has otherwise become a U.S. resident alien for tax purposes.

If you are a U.S. resident alien who is relying on an exception contained in the saving clause of a tax treaty to claim an exemption from U.S. tax on certain types of income, you must attach a statement to Form W-9 that specifies the following five items:

1. The treaty country. Generally, this must be the same treaty under which you claimed exemption from tax as a nonresident alien.
2. The treaty article addressing the income.
3. The article number (or location) in the tax treaty that contains the saving clause and its exceptions.
4. The type and amount of income that qualifies for the exemption from tax.
5. Sufficient facts to justify the exemption from tax under the terms of the treaty article.

Example. Article 20 of the U.S.-China income tax treaty allows an exemption from tax for scholarship income received by a Chinese student temporarily present in the United States. Under U.S. law, this student will become a resident alien for tax purposes if his or her stay in the United States exceeds 5 calendar years. However, paragraph 2 of the first Protocol to the U.S.-China treaty (dated April 30, 1984) allows the provisions of Article 20 to continue to apply even after the Chinese student becomes a resident alien of the United States. A Chinese student who qualifies for this exception (under paragraph 2 of the first protocol) and is relying on this exception to claim an exemption from tax on his or her scholarship or fellowship income would attach to Form W-9 a statement that includes the information described above to support that exemption.

If you are a nonresident alien or a foreign entity, give the requester the appropriate completed Form W-8 or Form 8233.

What is backup withholding? Persons making certain payments to you must under certain conditions withhold and pay to the IRS a percentage of such payments. This is called "backup withholding." Payments that may be subject to backup withholding include interest, tax-exempt interest, dividends, broker and barter exchange transactions, rents, royalties, nonemployee pay, payments made in settlement of payment card and third party network transactions, and certain payments from fishing boat operators. Real estate transactions are not subject to backup withholding.

You will not be subject to backup withholding on payments you receive if you give the requester your correct TIN, make the proper certifications, and report all your taxable interest and dividends on your tax return.

Payments you receive will be subject to backup withholding if:

1. You do not furnish your TIN to the requester,
2. You do not certify your TIN when required (see the Part II instructions on page 3 for details),
3. The IRS tells the requester that you furnished an incorrect TIN,
4. The IRS tells you that you are subject to backup withholding because you did not report all your interest and dividends on your tax return (for reportable interest and dividends only), or
5. You do not certify to the requester that you are not subject to backup withholding under 4 above (for reportable interest and dividend accounts opened after 1983 only).

Certain payees and payments are exempt from backup withholding. See *Exempt payee code* on page 3 and the separate instructions for the Requester of Form W-9 for more information.

Also see *Special rules for partnerships* on page 1.

What is FATCA reporting? The Foreign Account Tax Compliance Act (FATCA) requires a participating foreign financial institution to report all United States account holders that are specified United States persons. Certain payees are exempt from FATCA reporting. See *Exemption from FATCA reporting code* on page 3 and the instructions for the Requester of Form W-9 for more information.

Updating Your Information

You must provide updated information to any person to whom you claimed to be an exempt payee if you are no longer an exempt payee and anticipate receiving reportable payments in the future from this person. For example, you may need to provide updated information if you are a C corporation that elects to be an S corporation, or if you no longer are tax exempt. In addition, you must furnish a new Form W-9 if the name or TIN changes for the account, for example, if the grantor of a grantor trust dies.

Penalties

Failure to furnish TIN. If you fail to furnish your correct TIN to a requester, you are subject to a penalty of \$50 for each such failure unless your failure is due to reasonable cause and not to willful neglect.

Civil penalty for false information with respect to withholding. If you make a false statement with no reasonable basis that results in no backup withholding, you are subject to a \$500 penalty.

Criminal penalty for falsifying information. Willfully falsifying certifications or affirmations may subject you to criminal penalties including fines and/or imprisonment.

Misuse of TINs. If the requester discloses or uses TINs in violation of federal law, the requester may be subject to civil and criminal penalties.

Specific Instructions

Name

If you are an individual, you must generally enter the name shown on your income tax return. However, if you have changed your last name, for instance, due to marriage without informing the Social Security Administration of the name change, enter your first name, the last name shown on your social security card, and your new last name.

If the account is in joint names, list first, and then circle, the name of the person or entity whose number you entered in Part I of the form.

Sole proprietor. Enter your individual name as shown on your income tax return on the "Name" line. You may enter your business, trade, or "doing business as (DBA)" name on the "Business name/disregarded entity name" line.

Partnership, C Corporation, or S Corporation. Enter the entity's name on the "Name" line and any business, trade, or "doing business as (DBA) name" on the "Business name/disregarded entity name" line.

Disregarded entity. For U.S. federal tax purposes, an entity that is disregarded as an entity separate from its owner is treated as a "disregarded entity." See Regulation section 301.7701-2(c)(2)(ii). Enter the owner's name on the "Name" line. The name of the entity entered on the "Name" line should never be a disregarded entity. The name on the "Name" line must be the name shown on the income tax return on which the income should be reported. For example, if a foreign LLC that is treated as a disregarded entity for U.S. federal tax purposes has a single owner that is a U.S. person, the U.S. owner's name is required to be provided on the "Name" line. If the direct owner of the entity is also a disregarded entity, enter the first owner that is not disregarded for federal tax purposes. Enter the disregarded entity's name on the "Business name/disregarded entity name" line. If the owner of the disregarded entity is a foreign person, the owner must complete an appropriate Form W-8 instead of a Form W-9. This is the case even if the foreign person has a U.S. TIN.

Note. Check the appropriate box for the U.S. federal tax classification of the person whose name is entered on the "Name" line (Individual/sole proprietor, Partnership, C Corporation, S Corporation, Trust/estate).

Limited Liability Company (LLC). If the person identified on the "Name" line is an LLC, check the "Limited liability company" box only and enter the appropriate code for the U.S. federal tax classification in the space provided. If you are an LLC that is treated as a partnership for U.S. federal tax purposes, enter "P" for partnership. If you are an LLC that has filed a Form 8832 or a Form 2553 to be taxed as a corporation, enter "C" for C corporation or "S" for S corporation, as appropriate. If you are an LLC that is disregarded as an entity separate from its owner under Regulation section 301.7701-3 (except for employment and excise tax), do not check the LLC box unless the owner of the LLC (required to be identified on the "Name" line) is another LLC that is not disregarded for U.S. federal tax purposes. If the LLC is disregarded as an entity separate from its owner, enter the appropriate tax classification of the owner identified on the "Name" line.

Other entities. Enter your business name as shown on required U.S. federal tax documents on the "Name" line. This name should match the name shown on the charter or other legal document creating the entity. You may enter any business, trade, or DBA name on the "Business name/disregarded entity name" line.

Exemptions

If you are exempt from backup withholding and/or FATCA reporting, enter in the *Exemptions* box, any code(s) that may apply to you. See *Exempt payee code* and *Exemption from FATCA reporting code* on page 3.

Exempt payee code. Generally, individuals (including sole proprietors) are not exempt from backup withholding. Corporations are exempt from backup withholding for certain payments, such as interest and dividends. Corporations are not exempt from backup withholding for payments made in settlement of payment card or third party network transactions.

Note. If you are exempt from backup withholding, you should still complete this form to avoid possible erroneous backup withholding.

The following codes identify payees that are exempt from backup withholding:

- 1—An organization exempt from tax under section 501(a), any IRA, or a custodial account under section 403(b)(7) if the account satisfies the requirements of section 401(f)(2)
- 2—The United States or any of its agencies or instrumentalities
- 3—A state, the District of Columbia, a possession of the United States, or any of their political subdivisions or instrumentalities
- 4—A foreign government or any of its political subdivisions, agencies, or instrumentalities
- 5—A corporation
- 6—A dealer in securities or commodities required to register in the United States, the District of Columbia, or a possession of the United States
- 7—A futures commission merchant registered with the Commodity Futures Trading Commission
- 8—A real estate investment trust
- 9—An entity registered at all times during the tax year under the Investment Company Act of 1940
- 10—A common trust fund operated by a bank under section 584(a)
- 11—A financial institution
- 12—A middleman known in the investment community as a nominee or custodian
- 13—A trust exempt from tax under section 664 or described in section 4947

The following chart shows types of payments that may be exempt from backup withholding. The chart applies to the exempt payees listed above, 1 through 13.

IF the payment is for . . .	THEN the payment is exempt for . . .
Interest and dividend payments	All exempt payees except for 7
Broker transactions	Exempt payees 1 through 4 and 6 through 11 and all C corporations. S corporations must not enter an exempt payee code because they are exempt only for sales of noncovered securities acquired prior to 2012.
Barter exchange transactions and patronage dividends	Exempt payees 1 through 4
Payments over \$600 required to be reported and direct sales over \$5,000 ¹	Generally, exempt payees 1 through 5 ²
Payments made in settlement of payment card or third party network transactions	Exempt payees 1 through 4

¹ See Form 1099-MISC, Miscellaneous Income, and its instructions.

² However, the following payments made to a corporation and reportable on Form 1099-MISC are not exempt from backup withholding: medical and health care payments, attorneys' fees, gross proceeds paid to an attorney, and payments for services paid by a federal executive agency.

Exemption from FATCA reporting code. The following codes identify payees that are exempt from reporting under FATCA. These codes apply to persons submitting this form for accounts maintained outside of the United States by certain foreign financial institutions. Therefore, if you are only submitting this form for an account you hold in the United States, you may leave this field blank. Consult with the person requesting this form if you are uncertain if the financial institution is subject to these requirements.

- A—An organization exempt from tax under section 501(a) or any individual retirement plan as defined in section 7701(a)(37)
- B—The United States or any of its agencies or instrumentalities
- C—A state, the District of Columbia, a possession of the United States, or any of their political subdivisions or instrumentalities
- D—A corporation the stock of which is regularly traded on one or more established securities markets, as described in Reg. section 1.1472-1(c)(1)(i)
- E—A corporation that is a member of the same expanded affiliated group as a corporation described in Reg. section 1.1472-1(c)(1)(i)
- F—A dealer in securities, commodities, or derivative financial instruments (including notional principal contracts, futures, forwards, and options) that is registered as such under the laws of the United States or any state

- G—A real estate investment trust
- H—A regulated investment company as defined in section 851 or an entity registered at all times during the tax year under the Investment Company Act of 1940
- I—A common trust fund as defined in section 584(a)
- J—A bank as defined in section 581
- K—A broker
- L—A trust exempt from tax under section 664 or described in section 4947(a)(1)
- M—A tax exempt trust under a section 403(b) plan or section 457(g) plan

Part I. Taxpayer Identification Number (TIN)

Enter your TIN in the appropriate box. If you are a resident alien and you do not have and are not eligible to get an SSN, your TIN is your IRS individual taxpayer identification number (ITIN). Enter it in the social security number box. If you do not have an ITIN, see *How to get a TIN* below.

If you are a sole proprietor and you have an EIN, you may enter either your SSN or EIN. However, the IRS prefers that you use your SSN.

If you are a single-member LLC that is disregarded as an entity separate from its owner (see *Limited Liability Company (LLC)* on page 2), enter the owner's SSN (or EIN, if the owner has one). Do not enter the disregarded entity's EIN. If the LLC is classified as a corporation or partnership, enter the entity's EIN.

Note. See the chart on page 4 for further clarification of name and TIN combinations.

How to get a TIN. If you do not have a TIN, apply for one immediately. To apply for an SSN, get Form SS-5, Application for a Social Security Card, from your local Social Security Administration office or get this form online at www.ssa.gov. You may also get this form by calling 1-800-772-1213. Use Form W-7, Application for IRS Individual Taxpayer Identification Number, to apply for an ITIN, or Form SS-4, Application for Employer Identification Number, to apply for an EIN. You can apply for an EIN online by accessing the IRS website at www.irs.gov/businesses and clicking on Employer Identification Number (EIN) under Starting a Business. You can get Forms W-7 and SS-4 from the IRS by visiting irs.gov or by calling 1-800-TAX-FORM (1-800-829-3678).

If you are asked to complete Form W-9 but do not have a TIN, apply for a TIN and write "Applied For" in the space for the TIN, sign and date the form, and give it to the requester. For interest and dividend payments, and certain payments made with respect to readily tradable instruments, generally you will have 60 days to get a TIN and give it to the requester before you are subject to backup withholding on payments. The 80-day rule does not apply to other types of payments. You will be subject to backup withholding on all such payments until you provide your TIN to the requester.

Note. Entering "Applied For" means that you have already applied for a TIN or that you intend to apply for one soon.

Caution: A disregarded U.S. entity that has a foreign owner must use the appropriate Form W-8.

Part II. Certification

To establish to the withholding agent that you are a U.S. person, or resident alien, sign Form W-9. You may be requested to sign by the withholding agent even if items 1, 4, or 5 below indicate otherwise.

For a joint account, only the person whose TIN is shown in Part I should sign (when required). In the case of a disregarded entity, the person identified on the "Name" line must sign. Exempt payees, see *Exempt payee code* earlier.

Signature requirements. Complete the certification as indicated in items 1 through 5 below.

1. **Interest, dividend, and barter exchange accounts opened before 1984 and broker accounts considered active during 1983.** You must give your correct TIN, but you do not have to sign the certification.
2. **Interest, dividend, broker, and barter exchange accounts opened after 1983 and broker accounts considered inactive during 1983.** You must sign the certification or backup withholding will apply. If you are subject to backup withholding and you are merely providing your correct TIN to the requester, you must cross out item 2 in the certification before signing the form.
3. **Real estate transactions.** You must sign the certification. You may cross out item 2 of the certification.
4. **Other payments.** You must give your correct TIN, but you do not have to sign the certification unless you have been notified that you have previously given an incorrect TIN. "Other payments" include payments made in the course of the requester's trade or business for rents, royalties, goods (other than bills for merchandise), medical and health care services (including payments to corporations), payments to a nonemployee for services, payments made in settlement of payment card and third party network transactions, payments to certain fishing boat crew members and fishermen, and gross proceeds paid to attorneys (including payments to corporations).
5. **Mortgage interest paid by you, acquisition or abandonment of secured property, cancellation of debt, qualified tuition program payments (under section 529), IRA, Coverdell ESA, Archer MSA or HSA contributions or distributions, and pension distributions.** You must give your correct TIN, but you do not have to sign the certification.

What Name and Number To Give the Requester

For this type of account:	Give name and SSN of:
1. Individual	The individual
2. Two or more Individuals (joint account)	The actual owner of the account or, if combined funds, the first individual on the account ¹
3. Custodian account of a minor (Uniform Gift to Minors Act)	The minor ²
4. a. The usual revocable savings trust (grantor is also trustee)	The grantor-trustee ¹
b. So-called trust account that is not a legal or valid trust under state law	The actual owner ¹
5. Sole proprietorship or disregarded entity owned by an individual	The owner ¹
6. Grantor trust filing under Optional Form 1099 Filing Method 1 (see Regulation section 1.671-4(b)(2)(i)(A))	The grantor*
For this type of account:	Give name and EIN of:
7. Disregarded entity not owned by an individual	The owner
8. A valid trust, estate, or pension trust	Legal entity ⁴
9. Corporation or LLC electing corporate status on Form 8832 or Form 2553	The corporation
10. Association, club, religious, charitable, educational, or other tax-exempt organization	The organization
11. Partnership or multi-member LLC	The partnership
12. A broker or registered nominee	The broker or nominee
13. Account with the Department of Agriculture in the name of a public entity (such as a state or local government, school district, or prison) that receives agricultural program payments	The public entity
14. Grantor trust filing under the Form 1041 Filing Method or the Optional Form 1099 Filing Method 2 (see Regulation section 1.671-4(b)(2)(i)(B))	The trust

¹ List first and circle the name of the person whose number you furnish. If only one person on a joint account has an SSN, that person's number must be furnished.

² Circle the minor's name and furnish the minor's SSN.

³ You must show your individual name and you may also enter your business or "DBA" name on the "Business name/disregarded entity" name line. You may use either your SSN or EIN (if you have one), but the IRS encourages you to use your SSN.

⁴ List first and circle the name of the trust, estate, or pension trust. (Do not furnish the TIN of the personal representative or trustee unless the legal entity itself is not designated in the account title.) Also see *Special rules for partnerships* on page 1.

*Note. Grantor also must provide a Form W-9 to trustee of trust.

Note. If no name is circled when more than one name is listed, the number will be considered to be that of the first name listed.

Secure Your Tax Records from Identity Theft

Identity theft occurs when someone uses your personal information such as your name, social security number (SSN), or other identifying information, without your permission, to commit fraud or other crimes. An identity thief may use your SSN to get a job or may file a tax return using your SSN to receive a refund.

To reduce your risk:

- Protect your SSN,
- Ensure your employer is protecting your SSN, and
- Be careful when choosing a tax preparer.

If your tax records are affected by identity theft and you receive a notice from the IRS, respond right away to the name and phone number printed on the IRS notice or letter.

If your tax records are not currently affected by identity theft but you think you are at risk due to a lost or stolen purse or wallet, questionable credit card activity or credit report, contact the IRS Identity Theft Hotline at 1-800-908-4490 or submit Form 14039.

For more information, see Publication 4535, Identity Theft Prevention and Victim Assistance.

Victims of identity theft who are experiencing economic harm or a system problem, or are seeking help in resolving tax problems that have not been resolved through normal channels, may be eligible for Taxpayer Advocate Service (TAS) assistance. You can reach TAS by calling the TAS toll-free case intake line at 1-877-777-4778 or TTY/TDD 1-800-829-4059.

Protect yourself from suspicious emails or phishing schemes. Phishing is the creation and use of email and websites designed to mimic legitimate business emails and websites. The most common act is sending an email to a user falsely claiming to be an established legitimate enterprise in an attempt to scam the user into surrendering private information that will be used for identity theft.

The IRS does not initiate contacts with taxpayers via emails. Also, the IRS does not request personal detailed information through email or ask taxpayers for the PIN numbers, passwords, or similar secret access information for their credit card, bank, or other financial accounts.

If you receive an unsolicited email claiming to be from the IRS, forward this message to phishing@irs.gov. You may also report misuse of the IRS name, logo, or other IRS property to the Treasury Inspector General for Tax Administration at 1-800-366-4484. You can forward suspicious emails to the Federal Trade Commission at: spam@uce.gov or contact them at www.ftc.gov/idtheft or 1-877-IDTHEFT (1-877-438-4338).

Visit IRS.gov to learn more about identity theft and how to reduce your risk.

Privacy Act Notice

Section 6109 of the Internal Revenue Code requires you to provide your correct TIN to persons (including federal agencies) who are required to file information returns with the IRS to report interest, dividends, or certain other income paid to you; mortgage interest you paid; the acquisition or abandonment of secured property; the cancellation of debt; or contributions you made to an IRA, Archer MSA, or HSA. The person collecting this form uses the information on the form to file information returns with the IRS, reporting the above information. Routine uses of this information include giving it to the Department of Justice for civil and criminal litigation and to cities, states, the District of Columbia, and U.S. commonwealths and possessions for use in administering their laws. The information also may be disclosed to other countries under a treaty, to federal and state agencies to enforce civil and criminal laws, or to federal law enforcement and intelligence agencies to combat terrorism. You must provide your TIN whether or not you are required to file a tax return. Under section 3406, payers must generally withhold a percentage of taxable interest, dividend, and certain other payments to a payee who does not give a TIN to the payer. Certain penalties may also apply for providing false or fraudulent information.

**Certification
Regarding Debarment, Suspension and Ineligibility**

As is required by the Federal Regulations Implementing Executive Order 12549, Debarment and Suspension, 45 CFR Part 76, Government-wide Debarment and Suspension, the applicant certifies, to the best of his or her knowledge and belief, that both it and its principals:

- a. Are not presently debarred, suspended, proposed for debarment, declared ineligible, or voluntarily excluded from participation in this transaction by any federal department or agency;
- b. Have not within a three-year period preceding this bid proposal and/or application been convicted of or had a civil judgment rendered against them for commission of fraud or a criminal offense in connection with obtaining, attempting to obtain, or performing a public (federal, state, or local) transaction or contract under a public transaction, violation of federal or state antitrust statutes or commission of embezzlement, theft, forgery, bribery, falsification or destruction of records, making false statements, or receiving stolen property;
- c. Are not presently indicted for or otherwise criminally or civilly charged by a government entity with commission of any of the offenses enumerated herein; and
- d. Have not within a three-year period preceding this bid proposal and/or application had one or more public transactions terminated for cause or default.

Signature: _____
Print Name: _____
Title: _____
Telephone Number: _____
Date: _____

If the bidder is unable to certify to all of the statements in this Certification, such bidder should attach an explanation to this proposal.

as provided herein. This Lease shall terminate and become null and void without further notice on the expiration of the term specified in Article 1.1, unless sooner terminated or renewed and extended in accordance with this Article 1.2; and any holding over by Lessee after the expiration of that term shall not constitute a renewal of the Lease or give Lessee any rights under the Lease in or to the Leased Premises.

Holdover

1.2 If Lessee holds over and continues in possession of the Leased Premises after expiration of the term of this Lease, Lessee will be deemed to be occupying the Premises on the basis of a tenancy at sufferance, subject to all of the terms and conditions of this Lease. The inclusion of this Article 1.2 shall not be construed as Lessor's consent for Lessee to hold over.

Termination

1.3 Lessee may declare this Lease, and all rights and interest created by it, to be terminated upon giving the other party thirty (30) days written notice. Upon Lessee electing to terminate, this Lease shall cease and come to an end as if the day of the termination election were the day originally fixed in the Lease for its expiration.

Lessor's Warranty of Quiet Enjoyment

1.4. Lessor covenants and agrees that Lessee on paying the rent herein provided for and observing and keeping the covenants, conditions, and terms of this Lease on Lessee's part to be kept or performed, shall lawfully and quietly hold, occupy, and enjoy the Leased Premises during the term of this Lease without hindrance or molestation of Lessor or any person claiming under Lessor except such portion of the Leased Premises, if any, as shall be taken under the power of eminent domain.

ARTICLE 2. RENT

Base Rent

2.1 Lessee agrees to pay to Lessor, during the term hereof, a monthly rental equal to the product of \$_____(\$_____) dollars per month, of the Premises as described in Exhibit B. In the event the Commencement Date is a day other than the first day of the month, the rent for the period from the commencement date to the last day of the month shall be prorated by dividing the monthly rental by the number of calendar days in the month, and multiplying the result by the number of days remaining in the month that includes the Commencement.

Time and Manner of Payment

2.2 All rent due under this article shall be paid by Lessee on a monthly basis and in advance, on the 1st business day of each month commencing on the Commencement Date. All installments of rent shall be paid in lawful money of the United States to the Lessor Address in such location or locations as Lessor shall from time to time designate by written notice to Lessee. Any rent due for any partial month at the beginning or the end of the term hereof shall be prorated on the basis of a thirty day month.

Taxes

2.4 Lessor is responsible for rendering and paying all real estate taxes on the Property. Lessee shall be responsible for taxes, if any, on lessee's personal property located on the Premises.

ARTICLE 3. USE OF PREMISES

Permitted Use

3.1 Lessee may use the premises for landfill transfer and any other lawful purposes.

Waste, Nuisance, or Illegal Use

3.2 Lessee shall not use, or permit the use of, the Premises in any manner that results in waste of the Premises or constitutes a nuisance or violates any statute, ordinance, rule or regulation applicable to the premises or for any illegal purpose.

ARTICLE 4.

OMIT

ARTICLE 5. UTILITIES

Intentionally Deleted

ARTICLE 6. ALTERATIONS, ADDITIONS, AND IMPROVEMENTS

Consent of Lessor

6.1 Lessee shall not make any alterations, additions, or improvements to the Leased Premises without the prior written consent of Lessor. Consent for nonstructural alterations, additions, or improvements shall not be unreasonably withheld by Lessor.

Property of Lessor

6.2 All alterations, additions, or improvements made by Lessee shall become the property of Lessor at the termination of this Lease. Lessor may, however, require that Lessee remove any or all alterations, additions, and improvements installed or made by Lessee, and any other property placed on the Premises by Lessee, upon termination of the Lease. In the event that Lessor requires Lessee to remove such alterations, additions, or improvements, Lessee shall repair any damage to the Premises caused by such removal.

ARTICLE 7. SIGNS

Signs

7.1 Subject to the written approval of Lessor, and further subject to applicable laws, ordinances and regulations, Lessee shall have the right to install a sign on the Leased Premises.

Lessee must remove all signs at the termination of this Lease and repair any damage resulting from the erection or removal of the signs.

ARTICLE 8. MECHANIC'S LIEN

Lessee will not permit any mechanic's lien or liens to be placed upon the Leased Premises or improvements on the Premises, Lessee will promptly pay the lien. If default in payment of the lien continues for twenty (20) days after written notice from Lessor Lessee, Lessor may, at its option, pay the lien or any portion of it without inquiry as to its validity. Any amounts paid by the Lessor to remove a mechanic's lien caused to be filed against the Premises or improvements on the Premises by Lessee, including expenses and interest, shall be due from Lessee to Lessor and shall be repaid to Lessor immediately on rendition of notice, together with interest at ten percent (10%) per annum until repaid.

ARTICLE 9. INSURANCE AND INDEMNITY

Property Insurance

9.1 Lessor shall, at its own expense, during the term of this Lease provide, at its own expense, during the term of this Lease, keep all buildings and improvements on the Leased Premises insured against loss or damage by fire with extended coverage to include direct loss by windstorm, hail, explosion, riot, or riot attending a strike, civil commotion, aircraft, vehicles, and smoke, in the aggregate amounts of not less than the full fair insurable value of the buildings and improvements. The insurance is to be carried by one or more insurance companies licensed to do business in Texas and approved by Lessee. The policies shall provide that any proceeds for loss or damage to buildings or to improvements shall be payable solely to Lessor, which sum Lessor shall use for repair and restoration purposes as provided herein. Lessee shall maintain all insurance on Lessee's personal property located within the Leased Premises and Lessee covenants

and agrees that Lessor shall have no responsibility for damage or destruction of Lessee's personal property located within the Leased Premises.

General Liability Insurance

9.2 Lessee, at its own expense, shall provide and maintain in force during the term of this Lease liability insurance in the amounts deemed adequate by Lessor, naming Lessor as additional insured. Prior to occupancy of the Premises, lessee shall provide Lessor with evidence of such insurance.

Remedy for Failure to Provide Insurance

9.3 Lessee shall furnish Lessor with the original of all insurance policies required by this Article. If Lessee does not provide such policies or proof of such insurance within ten (10) days of the execution of this Lease, or if Lessee allows any insurance required under this Article to lapse after receipt of notice of cancellation or of non-renewal, or if Lessee fails to deliver proof of insurance showing coverages to Lessor prior to the effective date of such insurance and the original insurance policy within thirty (30) days thereafter, such failure shall be a default of Lessee under this Lease; or Lessor may, but shall not be required to take out such insurance and pay the premiums on the necessary insurance to comply with Lessee's obligations under the provisions of this Article. Lessee agrees to reimburse Lessor all amounts spent by Lessor to procure and maintain such insurance within fifteen (15) days after demand from Lessor. Failure to pay such amount when due shall be a default of Lessee under this Lease.

ARTICLE 10. DAMAGE OR DESTRUCTION OF PREMISES

Notice to Lessor

10.1 If the Leased Premises, or any structures or improvements on the Leased Premises, should be damaged or destroyed by fire, tornado, or other casualty, Lessee shall give immediate

written notice of the damage or destruction to Lessor, including a description of the damage and, as far as known to Lessee, the cause of the damage.

ARTICLE 11. CONDEMNATION

Total Condemnation

11.1 If during the term of this Lease all of the Leased Premises should be taken for any public or quasi-public use under any governmental law, ordinance, or regulation, or by right of eminent domain, or should be sold to the condemning authority under threat of condemnation, the Lease shall terminate, and the rent shall be abated during the unexpired portion of this Lease, effective as of the date of the taking of the premises by the condemning authority.

Partial Condemnation

11.2 If less than all, but more than ten percent (10%) of the Leased Premises is taken for any public or quasi-public use under any governmental law, ordinance, or regulation, or by right of eminent domain, or should be sold to the condemning authority under threat of condemnation, Lessee may terminate the Lease by giving written notice to Lessor within thirty (30) days after possession of the condemned portion is taken by the entity exercising the power of condemnation.

If the Leased Premises are partially condemned and Lessee fails to exercise the option to terminate the Lease under this section, or if less than ten percent (10%) of the Leased Premises are condemned, this Lease shall not terminate, but Lessor may, at its sole expense, restore and reconstruct the building and other improvements situated on the Leased Premises to make them reasonably tenantable and suitable for the uses for which the Premises are Leased. The rent payable under Sections 2.1 of this Lease shall be decreased equitably during the period of such restoration or reconstruction.

Condemnation Award

11.3 Lessor and Lessee shall each be entitled to receive and retain such separate awards, and portions of lump sum awards, as may be allocated to their respective interest in any condemnation proceedings. The termination of this Lease shall not affect the rights of the respective parties to such awards.

ARTICLE 12. DEFAULT

Default by Lessee

12.1 If Lessee shall allow the rent to be in arrears more than ten (10) days after written notice of such delinquency, or shall remain in default under any other condition of this Lease for a period of fifteen (15) days after written notice from Lessor, Lessor may at its option, without notice to Lessee, terminate this Lease or, in the alternative, Lessor may re-enter and take possession of the Premises and remove all persons and property without being deemed guilty of any manner of trespass and relet the Premises or any part of the Premises, for all or any part of the remainder of the Lease term, to a party satisfactory to Lessor and at such monthly rental as Lessor may with reasonable diligence be able to secure. Should Lessor be unable to relet after reasonable efforts to do so, or should such monthly rental be less than the rental Lessee was obligated to pay under this Lease, or any renewal of this Lease, plus the expense of reletting, then Lessee shall pay the amount of such deficiency plus reasonable attorney's fees to Lessor.

Lessor's Lien

12.2 It is expressly agreed that, in the event of default by Lessee in the payment of rent or any other sum due from Lessee to Lessor under the terms of this Lease, Lessor shall have a lien upon all fixtures, chattels, or other property of any description belonging to Lessee that are placed in, or become a part of, the Leased Premises as security for rent due and to become due for the remainder of the current Lease term and any other sum due from Lessee to Lessor. This lien shall not be in lieu of, or in any manner affect, the statutory landlord's lien given by law but shall be in

addition to that lien, and Lessee grants to Lessor a security interest in all of Lessee's property placed in or on the Leased Premises for purposes of this contractual lien. This shall not prevent the conduct of Lessee's business in the ordinary course of business and Lessee's actions in the ordinary conduct of Lessee's business shall be free of such lien to Lessor. In the event Lessor exercises the option to terminate the leasehold and re-enter and relet the Premises as provided in the preceding paragraph, then Lessor, after giving reasonable notice to Lessee of the intent to take possession and giving an opportunity for a hearing on the matter, may take possession of all of Lessee's property on the Premises and sell it at public or private sale after giving Lessee reasonable notice of the time and place of any public or private sale or of the time after that any private sale is to be made for cash or on credit, for such prices and terms as Lessor deems best, with or without having the property present at the sale. The proceeds of the sale shall be applied first to the necessary and proper expense of removing, storing and selling such property, then to repairing damage to the Leased Premises, if any, then to the payment of any rent due or to become due under this Lease, with balance, if any, to be paid to Lessee.

Default by Lessor

12/3 If Lessor defaults in the performance of any terms, covenants, or conditions required to be performed by it under this Lease, in addition to other remedies afforded Lessee under this Lease or at law, lessee may elect that:

Upon Lessee's notice to Lessor of repairs or maintenance which Lessor has a duty to undertake, Lessor neglects to make such repairs within sixty (60) days following written notice from Lessee. Lessee may vacate the Premises, in which case it shall be discharged from further payment of rent, the performance of all other terms and conditions of this Lease, and this Lease shall terminate as of the date Lessee vacates the Premises and any rental shall be abated for the unexpired term of this Lease.

Cumulative Remedies

12.4 All rights and remedies of Lessor and Lessee under this Article shall be cumulative, and none shall exclude any other right or remedy provided by law or by any other provision of this Lease. All such rights and remedies may be exercised and enforced concurrently and whenever, and as often, as occasion for their exercise arises.

Waiver of Breach

12.5 A waiver by either Lessor or Lessee of a breach of this Lease by the other party does not constitute a continuing waiver or a waiver of any subsequent breach of the Lease.

ARTICLE 13. ASSIGNMENT AND SUBLETTING

Assignment and Subletting by Lessee

14.1 Lessee may not sublet, assign, encumber, or otherwise transfer this Lease, or any right or interest in this Lease or in the Leased Premises or the improvements on the Leased Premises, without the written consent of Lessor. If Lessee sublets, assigns, encumbers, or otherwise transfers its rights or interest in this Lease or in the Leased Premises or the improvements on the Leased Premises, other than as specified herein, without the written consent of Lessor, Lessor may, at its option, declare this Lease terminated and Lessee and Lessor shall have no further obligation to each other under this Lease. In the event Lessor consents in writing to an assignment, sublease or other transfer of all or any of Lessee's rights under this Lease, the assignee or sublessee, must assume all of Lessee's obligations under this Lease, and Lessee shall remain liable for every obligation under the Lease. Lessor's consent under this section will not be arbitrarily or unreasonably withheld.

Assignment by Lessor

14.2 Lessor may assign or transfer any or all of its interests under the terms of this Lease.

ARTICLE 15. MISCELLANEOUS

Notices and Addresses

15.1 All notices required under this Lease will be deemed delivered when deposited in certified or registered mail, addressed to the proper party, at the following addresses:

Lessor:

Lessee:

County of Hidalgo
Attn: County Judge
100 E. Cano, 2nd Floor
Edinburg, Texas 78539

Either party may change the address to which notices are to be sent it by giving the other party notice of the new address in the manner provided in this section.

Parties Bound

15.2 This agreement shall be binding upon, and inure to the benefit of, the parties to the Lease and their respective heirs, executors, administrators, legal representatives, successors and assigns when permitted by this agreement.

Texas Law to Apply

15.3 This agreement shall be construed under, and in accordance with, the laws of the State of Texas, and all obligations of the parties created by this Lease are performable in Hidalgo County, Texas.

Legal Construction

15.4 In case any one or more of the provisions contained in this agreement shall for any reason be held by a court of competent jurisdiction to be invalid, illegal, or unenforceable in any respect, such invalidity, illegality, or unenforceability shall not affect any other provisions of the agreement, and this agreement shall be construed as if the invalid, illegal, or unenforceable provision had never been included in the agreement.

Prior Agreements Superseded

15.5 This agreement constitutes the sole and only agreement of the parties to the agreement and supersedes any prior understandings or written or oral agreements between the parties respecting the subject matter of this agreement.

Amendment

15.6 No amendment, modification, or alteration of the terms of this agreement shall be binding unless it is in writing, dated subsequent to the date of this agreement, and duly executed by the parties to this agreement.

Rights and Remedies Cumulative

15.7 The rights and remedies provided by this lease agreement are cumulative, and the use of any one right or remedy by either party shall not preclude or waive that party's right to use any or all other remedies. The rights and remedies provided in this Lease are in addition to any other rights the parties may have by law, statute, ordinance or otherwise.

Attorneys' Fees and Costs

15.8 If, as a result of a breach of this agreement by either party, the other party employs an attorney or attorneys to enforce its rights under this Lease, then the breaching or defaulting party agrees to pay the other party the reasonable attorneys' fees and costs incurred to enforce the Lease.

Force Majeure

15.9 Neither Lessor nor Lessee shall be required to perform any term, conditions, or covenant in this Lease so long as such performance is delayed or prevented by force majeure, which shall mean acts of God, strikes, lockouts, material or labor restrictions by any governmental authority, civil riot, floods, and any other cause not reasonably within the control of Lessor or

Lessee and which by the exercise of due diligence Lessor or Lessee is unable, wholly or in part, to prevent or overcome.

Real Estate Commission and Finder's Fees

15.10 Neither Lessor nor Lessee has entered into any real estate commission or finder's fee agreements with any broker, agent or finder in respect of this transaction, and Lessor and Lessee each agree to indemnify and hold harmless the other from and against any and all claims, losses, damages, costs or expenses of any kind, or arrangement or understanding alleged to have been made by the indemnifying party or on its behalf with any broker, salesman or finder in connection with this Lease or the transactions contemplated hereby.

Estoppel Information

15.11 Lessee shall, at the request of Lessor, provide any and all information with respect to this Lease to any person designated by Lessor.

Time of Essence

15.12 Time is of the essence of this agreement.

THE UNDERSIGNED Lessor and Lessee execute this Lease on the _____ day of _____, 20_____.

LESSOR:

By: _____

ATTEST:

LESSEE:

Arturo Guajardo, Jr., County Clerk

Ramon Garcia, County Judge

EXHIBIT "B"
BID PAGE

EXHIBIT "B"
HIDALGO COUNTY PRECINCT NO 1
"LEASE PARCEL FOR CITITZEN COLLECTION SITE(S) -1 IN MERCEDES AND 1
IN DONNA"
RFB NO.: 2015-013-12-09-SGS

Monthly Premium

The following fees are on a monthly basis only:

Location A: South of FM 493 and Mile West, Donna, Texas \$ _____

Location B: 1- Mile South of Business 83 on Mile 1 East,
Mercedes, Texas \$ _____

OPENED

9:34

12/9/15

Witnessed

➤ **Location A:**

Property ID and/or
Geographical ID: _____

Legal Description of Property: _____

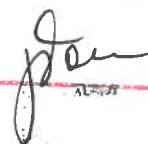

➤ **Location B:**

Property ID and/or
Geographical ID: _____

Legal Description of Property: _____

1 mile South of Bus 83, mile 1 E, Mercedes
South Portion of Capasillo E. 4.92 AC
LOT 9, BLK 67

(NIGP CODE: 971-35)

BIDDER'S INFORMATION:

BIDDER/COMPANY NAME: RAY JONES

ADDRESS: P.O. BOX 565

CITY/STATE/ZIP CODE: MERCEDES TX 78570

PHONE & FAX NO'S: (ph) 956-565-5490; (FAX) 956-565-4116

CELLULAR No. 956-454-6332

EMAIL ADDRESS: RCJONES@NETZERO.NET

AUTHORIZED SIGNATURE: Ray Jones

PRINTED NAME: RAY JONES

TITLE OWNER

EXHIBIT "A-1"
PROPERTY DESCRIPTION

1 Mile South of Business 83 on Mile 1 East, Mercedes, Texas

The East 4.92 acres of Lot #9, Block Sixty-Seven (67), Capisallo District Subdivision, Hidalgo County, Texas, as per plat thereof recorded in Volume "P", page 226, Deed Records, Hidalgo County, Texas.

**EXHIBIT “C”
INSURANCE REQUIREMENTS**



CERTIFICATE OF LIABILITY INSURANCE

DATE (MM/DD/YYYY)
12/21/2015

THIS CERTIFICATE IS ISSUED AS A MATTER OF INFORMATION ONLY AND CONFERS NO RIGHTS UPON THE CERTIFICATE HOLDER. THIS CERTIFICATE DOES NOT AFFIRMATIVELY OR NEGATIVELY AMEND, EXTEND OR ALTER THE COVERAGE AFFORDED BY THE POLICY BELOW. THIS CERTIFICATE OF INSURANCE DOES NOT CONSTITUTE A CONTRACT BETWEEN THE ISSUING INSURER(S), AUTHORIZED REPRESENTATIVE OR PRODUCER, AND THE CERTIFICATE HOLDER.

IMPORTANT: If the certificate holder is an ADDITIONAL INSURED, the policy(ies) must be endorsed. If SUBROGATION IS WAIVED, subject to the terms and conditions of the policy, certain policies may require an endorsement. A statement on this certificate does not confer rights to the certificate holder in lieu of such endorsement(s).

PRODUCER McAfee Insurance Agency P. O. Box 625 321 Second Street Mercedes TX 78570	CONTACT NAME: Consuelo Cavazos, CISR PHONE (A/C, No, Ext): (956) 565-2481 E-MAIL ADDRESS: consuelo@mcafeeagency.com	FAX (A/C, No): (956) 565-2733
	INSURER(S) AFFORDING COVERAGE	
INSURED Ray Jones P O Box 565 Mercedes TX 78570	INSURER A American States Ins Co of TX	
	INSURER B :	
	INSURER C :	
	INSURER D :	
	INSURER E :	
	INSURER F :	

COVERAGES **CERTIFICATE NUMBER:2015-2016** **REVISION NUMBER:** 00/0000

THIS IS TO CERTIFY THAT THE POLICIES OF INSURANCE LISTED BELOW HAVE BEEN ISSUED TO THE INSURED NAMED ABOVE FOR THE POLICY PERIOD INDICATED. NOTWITHSTANDING ANY REQUIREMENT, TERM OR CONDITION OF ANY CONTRACT OR OTHER DOCUMENT WITH RESPECT TO WHICH THIS CERTIFICATE MAY BE ISSUED OR MAY PERTAIN, THE INSURANCE AFFORDED BY THE POLICIES DESCRIBED HEREIN IS SUBJECT TO ALL THE TERMS, EXCLUSIONS AND CONDITIONS OF SUCH POLICIES. LIMITS SHOWN MAY HAVE BEEN REDUCED BY PAID CLAIMS.

INSR LTR	TYPE OF INSURANCE	ADDL SUBR INSR WVD	POLICY NUMBER	POLICY EFF (MM/DD/YYYY)	POLICY EXP (MM/DD/YYYY)	LIMITS
A	GENERAL LIABILITY	X	04FR005304-7	11/20/2015	11/20/2016	EACH OCCURRENCE \$ 250,000
	<input type="checkbox"/> COMMERCIAL GENERAL LIABILITY					DAMAGE TO RENTED PREMISES (Ea occurrence) \$ 50,000
	<input checked="" type="checkbox"/> Farm Liability					MED EXP (Any one person) \$ 5,000
	GEN'L AGGREGATE LIMIT APPLIES PER:					PERSONAL & ADV INJURY \$ 500,000
	<input checked="" type="checkbox"/> POLICY <input type="checkbox"/> PRO-JECT <input type="checkbox"/> LOC					GENERAL AGGREGATE \$ 500,000
B	AUTOMOBILE LIABILITY					PRODUCTS - COMP/OP AGG \$ 500,000
	<input type="checkbox"/> ANY AUTO					COMBINED SINGLE LIMIT (Ea accident) \$
	<input type="checkbox"/> ALL OWNED AUTOS	<input type="checkbox"/> SCHEDULED AUTOS				BODILY INJURY (Per person) \$
	<input type="checkbox"/> HIRED AUTOS	<input type="checkbox"/> NON-OWNED AUTOS				BODILY INJURY (Per accident) \$
C	UMBRELLA LIAB					PROPERTY DAMAGE (Per accident) \$
	<input type="checkbox"/> EXCESS LIAB	<input type="checkbox"/> OCCUR				\$
	<input type="checkbox"/> RETENTION \$	<input type="checkbox"/> CLAIMS-MADE				\$
D	WORKERS COMPENSATION AND EMPLOYERS' LIABILITY					WC STATUTORY LIMITS
	<input type="checkbox"/> ANY PROPRIETOR/PARTNER/EXECUTIVE OFFICER/MEMBER EXCLUDED? (Mandatory in NH)	<input type="checkbox"/> Y/N	N/A			OTHER
	If yes, describe under DESCRIPTION OF OPERATIONS below					E.L. EACH ACCIDENT \$
						E.L. DISEASE - EA EMPLOYEE \$
						E.L. DISEASE - POLICY LIMIT \$

DESCRIPTION OF OPERATIONS / LOCATIONS / VEHICLES (Attach ACORD 101, Additional Remarks Schedule, if more space is required)
County of Hidalgo shall be named as additional insured on above Farm Liability policy.
Lot 13 Blk 40 & Lot 9 Blk 67 S/E of Mercedes, TX 78570

CERTIFICATE HOLDER sandy.suarez@co.hidalgo.tx Hidalgo County. 2802 S. Business Hwy 281 Edinburg, TX 78539	CANCELLATION SHOULD ANY OF THE ABOVE DESCRIBED POLICIES BE CANCELLED BEFORE THE EXPIRATION DATE THEREOF, NOTICE WILL BE DELIVERED IN ACCORDANCE WITH THE POLICY PROVISIONS.
	AUTHORIZED REPRESENTATIVE Robert R Garza/CO <i>Robert R Garza</i>

Your Independent Liberty Mutual Insurance Agent:

MC AFEE AGENCY
PO BOX 625
MERCEDES, TX 78570

(956) 565-2481

RAY JONES
PO BOX 565
MERCEDES, TX 78570

**Your
COMMERCIAL INSURANCE POLICY**



AMERICAN STATES INSURANCE COMPANY OF TEXAS

A Stock Company
Safeco Plaza
Seattle, WA 98185-0001

2280
020000130058000004000150280





AMERICAN STATES INSURANCE COMPANY OF TEXAS

SEATTLE, WASHINGTON
COMMERCIAL INSURANCE POLICY

RENEWAL DECLARATIONS

NAMED INSURED AND MAILING ADDRESS
RAY JONES
PO BOX 565
MERCEDDES, TX 78570

POLICY NUMBER 04-FR-005304-8
RENEWAL OF 04-FR-005304-7 11-98

POLICY PERIOD FROM 11-20-15 TO 11-20-16 12:01 AM
STANDARD TIME AT LOCATION SHOWN ABOVE.

AGENT NAME AND ADDRESS
MC AFEE AGENCY
PO BOX 625
MERCEDDES, TX 78570

4252847 (956) 565-2481

THE TOTAL PREMIUM DUE FOR THE POLICY TERM IS \$500.00.
YOU WILL BE BILLED THROUGH YOUR CUSTOMER ACCOUNT #828-7548-860-01.
YOU NEED NOT PAY ANY PREMIUM AT THIS TIME. WE WILL SEND A BILLING
STATEMENT IN A SEPARATE MAILING.

IN RETURN FOR THE PAYMENT OF THE PREMIUM, AND SUBJECT TO ALL THE TERMS OF THIS POLICY, THE COMPANIES
INDICATED ON THE SPECIFIC COVERAGE PART DECLARATIONS AGREE WITH YOU TO PROVIDE THE INSURANCE AS
STATED IN THIS POLICY.

COMMERCIAL FARM COVERAGE PART \$ 500.00
500.00

020000140058000004000150281



COUNTERSIGNATURE

10-21-15
(DATE)

BY

(AUTHORIZED REPRESENTATIVE)

NAMED INSURED RAY JONES
 FORM OF BUSINESS: INDIVIDUAL

POLICY NO. 04-FR-005304-8

COVERAGE IS PROVIDED ONLY WHERE A LIMIT OF LIABILITY IS SHOWN FOR THE COVERAGE.

I. Limits of Liability			
Coverage H -	Bodily Injury and Property Damage Liability		
Coverage I -	Personal and Advertising Injury Liability	\$ 500,000	General Aggregate Limit
Coverage J -	Medical Payments		
Coverage H -	Bodily Injury and Property Damage Liability		
Coverage J -	Medical Payments	\$ 500,000	Each "Occurrence" Limit
Coverage I -	Personal and Advertising Injury Liability	\$ 500,000	
Coverage H -	Bodily Injury and Property Damage Liability		
	Fire Damage Limit	\$ 50,000	Any One Fire
Coverage J -	Medical Payments	\$ 5,000	Any One Person Limit
Additional Coverage b. - Damage to Property of Others		\$500	

II. Location of Insured Premises			
Loc No.	Description	No. of Acres	No. of Dwellings
1	LOT 13, BLK 40 & LOT 9, BLK 67 S/E OF MERCEDES, HIDALGO CO, TX	86.84	

III. Coverages		Premium
Coverage is only provided where a premium is shown.		
A. Basic Premium		\$500.00
B. Optional Premiums		
Insured Farm Employees - Employers Liability and Medical Payments under Coverages H and J		
Full-time farm employees		
Part-time farm employees		
Custom Farming -		
Additional Dwellings		
Additional Interests		
Other Coverages		

Forms Applicable:

FLO020(0690) FARM LIABILITY COVERAGE FORM	FLO163(1088) AMENDATORY ENDORSEMENT
FLO105(1187) TEXAS CHANGES	ILO275(1113) TX CHANGES - CANCELLATION AND
ILO168(0312) TX CHANGES - DUTIES	ILO017(1198) COMMON POLICY CONDITIONS

 3282
 020000150058000004000150282

Zimbra**evangelina.garcia@co.hidalgo.tx.us**

RE: Lease Agreement-Ray Jones-Lease of Mercedes Parcel-Precinct One

From : Steve Crain <scrain@atlashall.com>

Fri, Jan 15, 2016 04:10 PM

Subject : RE: Lease Agreement-Ray Jones-Lease of Mercedes Parcel-Precinct One**To :** 'Evangelina Garcia' <evangelina.garcia@co.hidalgo.tx.us>

The lease is fine. My condolences for your loss.

From: Evangelina Garcia [mailto:evangelina.garcia@co.hidalgo.tx.us]**Sent:** Friday, January 15, 2016 4:06 PM**To:** Steve Crain <scrain@atlashall.com>**Subject:** Re: Lease Agreement-Ray Jones-Lease of Mercedes Parcel-Precinct One

Mr. Crain;

My apologies as I was out of the office due to a death in my family and I'm now back in the office. Attached is the revised document as requested below for your review/approval in order to proceed with the next available agenda.

Respectfully;

Vangie Y. Garcia, Contract Manager
Hidalgo County Purchasing Department
2812 S. Business Hwy. 281
Edinburg, Texas 78539
Email: evangelina.garcia@co.hidalgo.tx.us
Phone: 956-292-7000-Ext. 4856

From: "Steve Crain" <scrain@atlashall.com>**To:** "Evangelina Garcia" <evangelina.garcia@co.hidalgo.tx.us>**Sent:** Wednesday, January 6, 2016 1:21:33 PM**Subject:** RE: Lease Agreement-Ray Jones-Lease of Mercedes Parcel-Precinct One

In Article 1.2 add in the eighth line after "Article 1.2" the following "or Article 1.4". Change and renumber the second Article 1.3 to Article to Article 1.4.

From: Evangelina Garcia [<mailto:evangelina.garcia@co.hidalgo.tx.us>]
Sent: Wednesday, January 06, 2016 11:46 AM
To: Steve Crain <scrain@atlashall.com>
Cc: Sandy Suarez <sandy.suarez@co.hidalgo.tx.us>
Subject: Lease Agreement-Ray Jones-Lease of Mercedes Parcel-Precinct One

Mr. Crain;

Attached for your review/approval is the "Lease Agreement" document with Ray Jones for the lease of parcel in the Mercedes Area-Precinct One so as to proceed with the finalization of this award.

Respectfully;

Vangie Y. Garcia, Contract Manager
Hidalgo County Purchasing Department
2812 S. Business Hwy. 281
Edinburg, Texas 78539
Email: evangelina.garcia@co.hidalgo.tx.us
Phone: 956-292-7000-Ext. 4856

AI-52689

Purchasing Department 12.
D. 1.

CC - REGULAR

Meeting Date: 01/26/2016

Submitted Marty Salazar, PURCHASING DEPT.

For:

Submitted By: Elena Gomez, PURCHASING DEPT.

Department: PURCHASING DEPT.

Information

CAPTION

Approval of Governmental Equipment Lease-Purchase Agreement No. 2758156 between Holt CAT Truck Center thru the Buyboard Contract# 431-13, Caterpillar financial Services Corporation and Hidalgo County for the lease-purchase of two (2) 2016 or newer CT660 Trucks for Pct 3 with authority for the County Judge to sign all related documents for financing purposes and subject to HB1295.

BACKGROUND

under Bid # 2016-023

Fiscal Impact

FISCAL YEAR: ACCT. #:

FUNDS AVAILABLE Y/N?: MATCHING FUNDS Y/N?:

BUDGETARY IMPACT:

Funding available pending approval of AI-53089

Attachments

Backup for Pct 3

Legal's approval

Agreement

Form Review

Inbox	Reviewed By	Date
Auditor's Office	Monica Badillo	01/22/2016 04:11 PM
Form Started By: Elena Gomez		Started On: 12/15/2015 11:57 AM
Final Approval Date: 01/22/2016		



CUSTOMER PROPOSAL

Customer Number:	0	Date:	12/15/2015
Customer Name:	County of Hidalgo PCT 3	Proposal good through:	2/15/2016
Description:	BUY BOARD CONTRACT #430.13 with Eaton Manual Transmission Roll-Off		
Address:	724 North Breygogle	Sales Representative	Mark Brunnemann - (956) 289-7636
City, State, Zip:	Mission, TX 78574	Registration Class:	
Contact Name:	Joe Flores	Requested G.V.W.R.	As per MSO or Title; no change
Contact Phone #:	956-585-4509		
Contact E-mail:	commissioner3@co.hidalgo.tx.us		

Stock/ID Number:	TBD
VIN:	As per MSO or Title; no change
To be delivered on or about:	12 to 16 Weeks From Approval
Freight on Board (F.O.B.)	HOLT TRUCK CENTER - Edinburg, TX

Make:	CAT
Model:	CT660S - Truck
Year:	2017

	Per Unit	Total
BUY BOARD BASE PRICE	\$105,098.61	\$210,197.22
Additional Vehicle and Accessories Description:	See Notes Below	See Notes Below
OPTIONAL ADDS	\$14,758.50	\$29,517.00
Galbreath UF-OR-174 60,000# Capacity with Pioneer	\$37,650.00	\$75,300.00
	\$0.00	\$0.00
BODY - 	\$0.00	\$0.00
NET Sales Price	\$157,507.11	\$315,014.23
TRADE-IN ALLOWANCE	\$0.00	\$0.00
Total Net Sales without Tax	\$157,507.11	\$315,014.23
BALANCE OWED ON TRADE-IN	\$0.00	\$0.00
DOWN PAYMENT	\$0.00	\$0.00
FET - FEDERAL EXCISE TAX	\$0.00	\$0.00
FET - FEDERAL EXCISE TAX - BODY	\$0.00	\$0.00
LSC - STATE MOTOR VEHICLE SALES TAX	\$0.00	\$0.00
PST - 1% TERP TAX (1997 & NEWER)	\$0.00	\$0.00
TTL - TITLE & REGISTRATION	\$0.00	\$0.00
VIT - VEHICLE INVENTORY TAX	\$0.00	\$0.00
ESC - Extended Service Coverage ESC Type - NONE	\$0.00	\$0.00
Out of State Vehicle Fee	\$0.00	\$0.00
Sales Price:	\$157,507.11	

Quantity:	2
-----------	---

Total Sales Price: \$ 315,014.23



CUSTOMER PROPOSAL

Customer Number:	0	Date:	12/15/2015
Customer Name:	County of Hidalgo PCT 3	Proposal good through:	2/15/2016
Description:	BUY BOARD CONTRACT #430.13 with Eaton Manual Transmission		Roll-Off
Additional Vehicle and Accessories Description:			
Hoist specifications attached			
Special Titling & Registration Notes:			
None			
Lienholder Notes:			
None			
TRADE-IN NOTES			
None			
DISCLAIMER:			
Any order based on this Proposal subject to Customer executing Dealer's standard for Retail Purchase Order incorporating above terms. Any documentary fees, state tax, title registration and license fees subject to adjustment and change. Actual F.E.T. to be paid by Dealer, subject to adjustment. Any F.E.T. variance will be responsibility of Dealer. Manufacturer has reserved the right to change the price to Dealer of any vehicle not currently in Dealer's stock, without notice to Dealer. If Quoted Vehicle's not currently in Dealers stock, Dealer reserves right to change Quotation Total to reflect any price increases from Manufacturer. This Proposal is based upon Dealer's current and expected inventory, which is subject to change. Dealer is not obligated to retain any specific vehicles in stock or maintain any specific inventory level. Dealer shall not be obligated to fulfill Proposal in event quoted vehicle's not in stock or available within requested delivery schedule at time Proposal accepted. Dealer shall not be liable for any delay in providing or inability to provide Quoted Vehicle's, where such inability or delay is due, in whole or in part, to any cause beyond the reasonable control of Dealer or is without the gross negligence or intended misconduct of Dealer. Above listed Trade Value based upon current appraisal of Trade Vehicle's. Dealer may adjust Trade Value of Trade Vehicle's to reflect changes in condition and/or mileage of Trade Vehicle's between date of current appraisal and acceptance of this Proposal by Customer.			
SELLER:		BUYER:	
Mark Brunnemann			
Signature		Signature	
Mark Brunnemann			
Printed Name:		Printed Name:	
Sales Representative			
Title:		Title:	
12/15/2015			
Date:		Date:	

Thank you for the opportunity to earn your business. We look forward to working with you on your business needs.

2016-023
TWO (2) CT660S-TRUCK (PCT 3)



Phone: 800-695-2919
Fax: 800-211-5454
Email: info@buyboard.com

Welcome Elena [Log Off]

- Administration
- RFQ
- Reports
- Shopping Cart
- Help

Vendor Contract Information

[Back](#)

Search:

- All
- Vendor Discounts Only
- Catalog Pricing Only

Refine Your Search:

Vendors

Holt CAT Truck Centers[X]

Price Range

Show all prices

Category

None Selected

Contract

None selected

Additional Searches:

[Search by Vendor](#)

[Browse Contracts](#)

[Additional Resources](#)

Vendor Name: Holt CAT Truck Centers
Address: 415 N. Walton Walker Loop 12
 Irving, TX 75061
Phone Number: (214) 596-7570
Email: mark.mims@holcat.com
Federal ID: 74-1389993
Contact: Mark Mims
Accepts RFQs: Yes
Minority Owned Vendor: No
Women Owned Vendor: No
Contract Name: Vehicles, Heavy Duty Trucks & Options
Contract#: 430-13
Effective Date: 12/01/2013
Expiration Date: 11/30/2016
Service Fee: Purchase order subject to a \$400 service fee
Payment Terms: Net 30 days
Delivery Days: 180
Shipping Terms: Pre-paid and added to invoice
Freight Terms: FOB Destination
Ship Via: Common Carrier
Region Served: All Texas Regions
States Served: All States
Additional Info: NOTE: As per the specifications for BuyBoard Proposal No. 430-13, and except for delivery fees as explained below, all vehicle fees (i.e. pre-deliver inspection, make ready, State of Texas inspection, manufacturer destination fees, etc.) charged for any purchase from this contract are included in the awarded vehicle base price(s). Vehicle fees not included in the price(s) are not allowed and should not appear on the awarded dealer's quote for a vehicle offered for purchase under the contract. The Cooperative service fee is not a "vehicle fee" and is not included in the base pricing. Only those vendors whose awarded pricing is stated on the BuyBoard on a per mile basis may charge a vehicle delivery fee. The above information has been communicated to Cooperative members.

Quote Reference Number: 430-13
Return Policy: Case by case review
Additional Dealers: See Extended Exceptions for dealer list.

Contract Documents

- Proposal Documents:** [Click to view BuyBoard Proposal Documents](#)
- Extended Exceptions:** [Click to view Extended Contract Exceptions](#)
- Regulatory Notice:** [Click to view Bonding Regulatory Notice](#)

Contact us 800-695-2919

Shopping Cart

Vendor	Description	Part Number	Price	Qty	Total
Holt CAT Truck Centers	CAT CT660S-Truck. SBA, Truck Config., 116" BBC, 796-01 cab and chassis, 52,300# GVW, Fuller 10 speed transmission, 365 HP, front axle 13,200lbs, rear axle 40,000lbs, complete with all manufacturer's standard equipment. Line Item 376	CAT CT660S	\$105,499.80	1	\$105,499.80
Grand Total:					\$105,499.80

Vendor	Description
Holt CAT Truck Centers	0% Discount Off Holt Cat Truck Centers pricelist for Caterpillar Opllonal Equipment. Line Item 382
Holt CAT Truck Centers	0% Discount Off Holt Cat Truck Centers pricelist for Third Party Caterpillar (not OEM Options). Line Item 384

2015 Capital Lease Versus Operating Lease Test

2016-023 2 CT660S TRUCK (PCT 3)

Tab	CC Date	Dept No.	Install Date	Serial Number	Department Lease / Property	Req. No.	Asset Module Asset ID No.	Model Description	Monthly Pymt Amount	Title Xfer at End of Lease? (Y/N)	Bargain Purchase Option? (Y/N)	Lease Term in Months	Est. Economic Useful Life in Mo.'s	Total Principal Pmts Over Lease Term	FMV of Leased Equip. at Lease Inception	Capital or Operating Lease? (Calculated Field)	% Interest
32	10/27/2015	124			Pct 4 - S.C. Cmm Ctr	286072	DIR-TSO-3043	5945APT	\$156.10	N	N	36	60	\$5,619.60	\$5,156.00	Capital Lease	5.676
33	11/24/2015	121			Precinct 1	287307	BB 430-13	2-Holt CT660	\$5,334.29	Y	Y	84	84	\$448,080.36	\$408,138.64	Capital Lease	2.689
34	10/29/2015	330			Juv. Prob New-Court	286556	DIR-TSO-3043	WC3655X	\$64.38	N	N	36	60	\$2,317.68	\$2,177.00	Capital Lease	4.110
35		330			Juv. Prob Intake	286813	DIR-TSO-3043	WC3655X	\$64.38	N	N	36	60	\$2,317.68	\$2,177.00	Capital Lease	4.110
36		330			Juv. Prob Boot Aftercar	286818	DIR-TSO-3043	WC3655X	\$64.38	N	N	36	60	\$2,317.68	\$2,177.00	Capital Lease	4.110
37		330			Juv. Prob Detention	286834	DIR-TSO-3043	WC5955APT	\$180.40	N	N	36	60	\$6,494.40	\$5,783.00	Capital Lease	7.693
38		330			Juv. Prob Probation	286840	DIR-TSO-3043	WC5955APT	\$180.40	N	N	36	60	\$6,494.40	\$5,783.00	Capital Lease	7.693
39		330			Juv. Prob Court Intake	286848	DIR-TSO-3043	WC5955APT	\$180.40	N	N	36	60	\$6,494.40	\$5,783.00	Capital Lease	7.693
40		330			Juv. Prob Boot Camp	286820	DIR-TSO-3043	WC5865APT	\$235.66	N	N	36	60	\$8,483.76	\$7,596.00	Capital Lease	7.321
41		122			Hidalgo Co. Pct 2	287970	DIR-TSO-3101	C250IF	\$95.47	N	N	36	60	\$3,436.92	\$2,893.00	Capital Lease	11.551
42		123			Comm. Pct 3		BB 430-13	2-Holt CT660	\$4,118.21	Y	Y	84	84	\$345,929.64	\$315,014.22	Capital Lease	2.690
43									\$0.00					\$0.00			
44									\$0.00					\$0.00			
45									\$0.00					\$0.00			
46									\$0.00					\$0.00			
47									\$0.00					\$0.00			
49									\$0.00					\$0.00			
50									\$0.00					\$0.00			
51									\$0.00					\$0.00			
52									\$0.00					\$0.00			
53									\$0.00					\$0.00			
54									\$0.00					\$0.00			
55									\$0.00					\$0.00			
56									\$0.00					\$0.00			
57									\$0.00					\$0.00			
58									\$0.00					\$0.00			
59									\$0.00					\$0.00			
60									\$0.00					\$0.00			
61									\$0.00					\$0.00			
62									\$0.00					\$0.00			
63									\$0.00					\$0.00			
64									\$0.00					\$0.00			
65									\$0.00					\$0.00			

2. Enter values in the mandatory fields (green highlight) are entered and the optional fields (peach highlighted), if available.

Lease Calculator

Fix Rate	Fix Payment
Product/Property Value	\$ 315014.22
Residual Value	\$ 0
Lease Term	7 years 0 months
Monthly Payment	\$ 4118.21
Calculate	

Result

Interest/Return Rate	2.688%
Total of 84 Monthly Payments	\$345,929.64
Total Interest	\$30,915.42

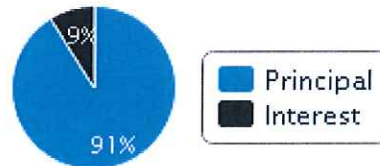

Note: Actual Payments are Annual Payments of \$49,418.54 (above calculator only calculated monthly payments; $\$49,418.54 / 12 = \$4,118.21$)

2016-023
TWO (2) CT660S-TRUCK (PCT 3)



CT660S SBA 6x4

Sales Proposal For:
Hidalgo County PCT 3 - Manual Trans

Presented By:
HOLT TEXAS LTD.



2016-023
TWO (2) CT660S-TRUCK (PCT 3)

November 22, 2015

Prepared For:
Hidalgo County PCT 3 - Manual Trans

Reference ID: Manual 8LL

Presented By:
HOLT TEXAS LTD.
Mark Brunnemann
3302 S W W WHITE RD
SAN ANTONIO TX 78222 - 4843
(210)648-8343

We are pleased to have the opportunity to offer the following proposal for the application you requested.

Model Profile

2017 CT660S SBA 6x4 (CF7AA)

APPLICATION:	Roll-On/Roll-off
MISSION:	Requested GVWR: 66000. Calc. GVWR: 66000 Calc. Start / Grade Ability: 24.83% / 1.64% @ 55 MPH Calc. Geared Speed: 91.8 MPH
DIMENSION:	Wheelbase: 260.00, CA: 198.00, Axle to Frame: 65.00
ENGINE, DIESEL:	{CT 13} EPA 2010, SCR, 390 HP @ 1700 RPM, 1450 lb-ft Torque @ 1000 RPM, 2100 RPM Governed Speed, 390 Peak HP (Max)
TRANSMISSION, MANUAL:	{Fuller RTO(F)-14908LL} 10-Speed Manual; Double Lo With Overdrive and With Air Shift
CLUTCH:	{Eaton Fuller Easy-Pedal Advantage} Manual Adjust, Two-Plate, Cast Angle Spring; Ceramic, 15.5" Diameter, 7-Spring Damper, Mechanical Pull-Type Control, 1700 lb-ft Torque Capacity
AXLE, FRONT NON-DRIVING:	{Meritor MFS-20-133A} Wide Track, I-Beam Type, 20,000-lb Capacity
AXLE, REAR, TANDEM:	{Meritor RT-46-160P} Single Reduction, 46,000-lb Capacity, With Lube Pump, 200 Wheel Ends Gear Ratio: 3.73
CAB:	Conventional
TIRE, FRONT:	(2) 425/65R22.5 XZY-3 (MICHELIN) 465 rev/mile, load range L, 20 ply
TIRE, REAR:	(8) 11R22.5 XDN2 (MICHELIN) 497 rev/mile, load range H, 16 ply
SUSPENSION, REAR, TANDEM:	{Hendrickson RT-463} Walking Beam Type 54" Axle Spacing; 46,000-lb Capacity With Bronze Center Bushings
FRAME REINFORCEMENT:	Outer "C" Channel, Heat Treated Alloy Steel (120,000 PSI Yield); 12.65" x 3.50" x 0.25"(321.0mm x 88.9mm x 6.35mm); 445.4" (11313mm) Maximum OAL
PAINT:	Cab schematic 100KT Location 1: 9219, Winter White (Std) Chassis schematic N/A



2016-023
TWO (2) CT660S-TRUCK (PCT 3)
Vehicle Specifications

November 22, 2015

2017 CT660S SBA 6x4 (CF7AA)

<u>Code</u>	<u>Description</u>	<u>F/R Wt</u> (lbs)	<u>Tot Wt</u> (lbs)	<u>List</u> (US DOLLAR)
CF7AA00	Base Chassis, Model CT660S SBA 6x4 with 260.00 Wheelbase, 198.00 CA, and 65.00 Axle to Frame.	9385/6587	15972	\$139,218.02
1570	TOW HOOK, FRONT (2) Frame Mounted	47/-7	40	\$372.38
1DAV	FRAME RAILS High Strength Heat Treated Alloy Steel (120,000 PSI Yield); 12.00" x 3.25" x 0.25" (304.8mm x 82.6mm x 6.35mm); 478.1" (12143mm) Maximum OAL	20/70	90	(\$219.73)
1GDL	FRAME REINFORCEMENT Outer "C" Channel, Heat Treated Alloy Steel (120,000 PSI Yield); 12.65" x 3.50" x 0.25"(321.0mm x 88.9mm x 6.35mm); 445.4" (11313mm) Maximum OAL	270/533	803	\$1,912.60
1LBC	BUMPER, FRONT Multi-piece Stainless Steel	0/0	0	\$0.00
	<u>Includes</u> : FOG LIGHT OPENING (2) and with Rectangular Hole for Step			
1SAP	CROSSMEMBER, REAR, AF (1) 5 Piece	-12/75	63	\$145.13
1WVT	WHEELBASE RANGE 230" (585cm) Through and Including 285" (725cm)	0/0	0	\$1,251.48
2ARY	AXLE, FRONT NON-DRIVING {Meritor MFS-20-133A} Wide Track, I-Beam Type, 20,000-lb Capacity	125/0	125	\$2,105.21
3AGA	SUSPENSION, FRONT, SPRING Parabolic, Taper Leaf; 20,000-lb Capacity; With Shock Absorbers	-101/0	-101	\$423.77
4091	BRAKE SYSTEM, AIR Dual System for Straight Truck Applications	0/0	0	\$0.00
	<u>Includes</u> : BRAKE LINES Color and Size Coded Nylon : DRAIN VALVE Twist-Type : DUST SHIELDS, FRONT BRAKE : DUST SHIELDS, REAR BRAKE : GAUGE, AIR PRESSURE (2) Air 1 and Air 2 Gauges; Located in Instrument Cluster : INVERSION VALVE Bendix SR-1 and Double Check Valve : PARKING BRAKE CONTROL Yellow Knob, Located on Instrument Panel : PARKING BRAKE VALVE For Truck : QUICK RELEASE VALVE Bendix On Rear Axle for Spring Brake Release: 1 for 4x2, 2 for 6x4 : SLACK ADJUSTERS, FRONT Automatic : SLACK ADJUSTERS, REAR Automatic : SWITCH, AUXILIARY Interrupter for Cab Clearance/Marker Lights (Blinks Lights with Headlight Switch in "ON" Position); Instrument Panel Mounted			
	<u>Notes</u> : The following features should be considered when calculating Rear GAWR: Rear Axles; Rear Suspension; Brake System; Brakes, Rear Air Cam; Brake Shoes, Rear; Special Rating, GAWR; Wheels; Tires.			
4193	BRAKES, FRONT, AIR CAM 16.5" x 6", Includes 24 SqIn Long Stroke Brake Chambers	115/0	115	\$0.00
4732	DRAIN VALVE (Berg) Manual; With Pull Chain, for Air Tank	0/0	0	\$0.00



2016-023
TWO (2) CT660S-TRUCK (PCT 3)
Vehicle Specifications

November 22, 2015

2017 CT660S SBA 6x4 (CF7AA)

<u>Code</u>	<u>Description</u>	<u>F/R Wt</u> (lbs)	<u>Tot Wt</u> (lbs)	<u>List</u> (US DOLLAR)
	<u>Includes</u> : DRAIN VALVE Mounted in Wet Tank			
4AZJ	AIR BRAKE ABS {Bendix AntiLock Brake System} Full Vehicle Wheel Control System (4-Channel) With Automatic Traction Control	0/0	0	\$163.04
4EBS	AIR DRYER {Bendix AD-9} With Heater	0/0	0	\$0.00
	<u>Includes</u> : AIR DRYER LOCATION Inside Left Rail, Back of Cab			
4EXU	BRAKE CHAMBERS, REAR AXLE {Bendix EverSure} 30/30 Spring Brake	0/0	0	\$0.00
4EXV	BRAKE CHAMBERS, FRONT AXLE {Bendix} 24 SqIn	0/0	0	\$0.00
4NDB	BRAKES, REAR, AIR CAM S-Cam; 16.5" x 7.0"; Includes 30/30 Sq.In. Long Stroke Brake Chamber and Spring Actuated Parking Brake	0/0	0	\$0.00
4SPM	AIR COMPRESSOR {Bendix BA-921 Head Unload} 15.9 CFM Capacity, Single Cylinder	0/0	0	\$0.00
5710	STEERING COLUMN Tilting and Telescoping	0/0	0	\$0.00
5PTB	STEERING GEAR (2) {Sheppard M-100/M-80} Dual Power	122/-9	113	\$1,047.23
5WBH	STEERING WHEEL {Caterpillar} 2-Spoke, 18" Diam., Dark Neutral, Leather Wrapped	0/0	0	\$0.00
7BJU	EXHAUST SYSTEM Switchback Horizontal Aftertreatment Device, Frame Mounted Right Side Under Cab; Includes Single Vertical Tail Pipe & Guard, Right Side, Cab Mounted	0/0	0	\$0.00
7WBA	TAIL PIPE (1) Turnback Type, Bright, for Single Exhaust	0/0	0	\$145.13
7WBS	MUFFLER/TAIL PIPE GUARD (1) Bright Stainless Steel	6/1	7	\$119.15
8000	ELECTRICAL SYSTEM 12-Volt, Standard Equipment	0/0	0	\$0.00
	<u>Includes</u> : BATTERY BOX Aluminum : CIGAR LIGHTER Includes Ash Cup, Center Console Mounted : FUSES, ELECTRICAL SAE Blade-Type : HAZARD SWITCH Integral with Turn Signal Switch : HEADLIGHT DIMMER SWITCH Integral with Turn Signal Lever : HEADLIGHTS (2) Composite with Halogen Projector Beam : HORN, AIR Single, Chrome : HORN, ELECTRIC Single : PARKING LIGHT Integral with Front Turn Signal and Rear Tail Light : READING LIGHT, CAB (2) with Individual Switches; One Above Each Door : STARTER SWITCH Electric, Key Operated : STOP, TURN, TAIL & B/U LIGHTS Dual, Rear, Combination with Reflector : TURN SIGNAL FLASHER : TURN SIGNAL SWITCH Manual Cancelling with Lane Change Feature : TURN SIGNALS, FRONT Includes Integral Reflectors and Side Marker Lights; Fender Mounted			



2016-023
TWO (2) CT660S-TRUCK (PCT 3)

Vehicle Specifications

November 22, 2015

2017 CT660S SBA 6x4 (CF7AA)

<u>Code</u>	<u>Description</u>	<u>F/R Wt</u> (lbs)	<u>Tot Wt</u> (lbs)	<u>List</u> (US DOLLAR)
	: WINDSHIELD WIPER SWITCH 2-Speed with Wash and Intermittent Feature, Steering Column Mounted : WINDSHIELD WIPERS Single Motor, Electric, Cowl Mounted : WIRING, CHASSIS Color Coded and Continuously Numbered			
8653	HORN, AIR Single, Located Under Cab	5/0	5	\$0.00
8718	POWER SOURCE Cigar Type Receptacle without Plug and Cord	0/0	0	\$0.00
8GGN	ALTERNATOR {Bosch LH160} Brush Type, 12 Volt 160 Amp. Capacity, Pad Mount	0/0	0	\$0.00
8HAB	BODY BUILDER WIRING Back of Standard Cab at Left Frame or Under Extended or Crew Cab at Left Frame; Includes Sealed Connectors for Tail/Amber Turn/Marker/ Backup/Accessory Power/Ground and Sealed Connector for Stop/Turn	2/1	3	\$96.75
8MMJ	BATTERY SYSTEM {Caterpillar} (3) 12 Volt 2130CCA Total	0/0	0	\$0.00
8RMA	RADIO AM/FM/WB/Clock/Bluetooth/USB Input/3MM Auxiliary Input, MP3, Apple Device Play & Control, Bluetooth for Phone & Music, with Multiple Speakers	1/0	1	\$432.69
8RMG	ANTENNA BASE (2) Single Function, (1) for CB and (1) for Entertainment Radio, Without Splitter, Separate Lead-Ins, With CB Antenna Mounted on Left Mirror and AM/FM Antenna Mounted on Right Mirror	0/0	0	\$0.00
8VUK	BATTERY BOX Aluminum With Plastic Cover, 18" Wide, 2, 3, or 4 Battery Capacity, Mounted Right Side Back of Cab	0/0	0	\$0.00
8WCK	POWER SOURCE, TERMINAL TYPE 2-Post	0/0	0	\$0.00
8WEZ	TURN SIGNAL SWITCH Self-Canceling	0/0	0	\$0.00
8WNH	RUNNING LIGHT (2) Daytime	0/0	0	\$0.00
8WNT	CLEARANCE/MARKER LIGHTS (5) Amber LED Lights, Mounted on Sunshade	0/0	0	\$63.86
8WXG	STARTING MOTOR {Mitsubishi Electric Automotive America 105P} 12-Volt, with Soft-Start	0/0	0	\$0.00
8XAH	CIRCUIT BREAKERS Manual-Reset (Main Panel) SAE Type III With Trip Indicators, Replaces All Fuses Except For 5-Amp Fuses	0/0	0	\$88.69
8XCC	TOGGLE SWITCH, AUXILIARY (2) with Two 20-Amp Fuses/ Circuit Breakers	1/0	1	\$67.19
9ASE	FRONT END Tilting Composite	0/0	0	\$0.00
	<u>Includes</u> : GRILLE SURROUND Brushed Stainless Steel			
9HAN	INSULATION, UNDER HOOD for Sound Abatement	0/0	0	\$0.00
9HBN	INSULATION, SPLASH PANELS for Sound Abatement	0/0	0	\$0.00
10060	PAINT SCHEMATIC, PT-1 Single Color, Design 100	0/0	0	\$0.00
10761	PAINT TYPE Base Coat/Clear Coat, 1-2 Tone	0/0	0	\$0.00

2016-023
TWO (2) CT660S-TRUCK (PCT 3)



Vehicle Specifications

November 22, 2015

2017 CT660S SBA 6x4 (CF7AA)

<u>Code</u>	<u>Description</u>	<u>F/R Wt</u> (lbs)	<u>Tot Wt</u> (lbs)	<u>List</u> (US DOLLAR)
11MGZ	CLUTCH {Eaton Fuller Easy-Pedal Advantage} Manual Adjust, Two-Plate, Cast Angle Spring; Ceramic, 15.5" Diameter, 7-Spring Damper, Mechanical Pull-Type Control, 1700 lb-ft Torque Capacity <u>Includes</u> : CLUTCH RELEASE BEARING Greasable	0/0	0	\$0.00
12KXN	ENGINE, DIESEL {CT 13} EPA 2010, SCR, 390 HP @ 1700 RPM, 1450 lb-ft Torque @ 1000 RPM, 2100 RPM Governed Speed, 390 Peak HP (Max)	0/0	0	\$200.67
12THT	FAN DRIVE {Horton Drivemaster} Direct Drive Type, Two Speed With Residual Torque Device for Disengaged Fan Speed	0/0	0	\$0.00
12UND	FEDERAL EMISSIONS EPA, OBD and GHG Certified for Calendar Year 2015; CT13 Engines	0/0	0	\$8,000.00
12VBT	AIR CLEANER Single Element, Heavy Duty	0/0	0	\$0.00
12WBR	FAN OVERRIDE Manual; With Electric Switch on Instrument Panel, (Fan On With Switch On)	2/0	2	\$28.06
12WCX	HOSE CLAMPS, RADIATOR HOSES {Gates} Shrink Band Type	0/0	0	\$0.00
12WEG	COLD STARTING EQUIPMENT Automatic; With Engine ECM Control	0/0	0	\$0.00
12WTA	FAN DRIVE SPECIAL EFFECTS Fan Cooling Ring with Fan Shroud Effects, Engine Mounted	0/0	0	\$0.00
12WZE	EMISSION COMPLIANCE Federal, Does Not Comply With California Clean Air Idle Regulations	0/0	0	\$0.00
12XAV	RADIATOR Aluminum; Welded, Front to Back Down Flow System, 1429 SqIn, 740 SqIn CAC, 1099 SqIn 3 Core LTR	0/0	0	\$0.00
13GHW	TRANSMISSION, MANUAL {Fuller RTO(F)-14908LL} 10-Speed Manual; Double Lo With Overdrive and With Air Shift <u>Includes</u> : CLUTCH BRAKE Torque Limiting : FILL PLUG, MAGNETIC	-38/-7	-45	\$3,120.08
13WLB	TRANSMISSION OIL {EmGard 50W} Synthetic; 22 thru 33.99 Pints	0/0	0	\$101.23
13WVD	PTO CONTROL, DASH MOUNTED For Customer Provided PTO; Includes Control Valve, Piping and Wiring, Wired for PTO	2/0	2	\$53.75
14862	PDL WARNING BUZZER Power Divider Lock	0/2	2	\$26.88
14AJX	SHIELD, TEMPERATURE SENSOR Mounted to Rear Axle	0/3	3	\$41.21
14GRR	AXLE, REAR, TANDEM {Meritor RT-46-160P} Single Reduction, 46,000-lb Capacity, With Lube Pump, 200 Wheel Ends . Gear Ratio: 3.73 <u>Includes</u> : POWER DIVIDER LOCK Air Operated, Cab Control with Indicator Light in Cluster : REAR AXLE DRAIN PLUG (2) Magnetic, For Tandem Rear Axle	0/494	494	\$3,856.56



2016-023
TWO (2) CT660S-TRUCK (PCT 3)

Vehicle Specifications

November 22, 2015

2017 CT660S SBA 6x4 (CF7AA)

<u>Code</u>	<u>Description</u>	<u>F/R Wt</u> (lbs)	<u>Tot Wt</u> (lbs)	<u>List</u> (US DOLLAR)
14UHK	SUSPENSION, REAR, TANDEM {Hendrickson RT-463} Walking Beam Type 54" Axle Spacing; 46,000-lb Capacity With Bronze Center Bushings <u>Includes</u> : CROSSMEMBER, SUSPENSION 5-Piece <u>Notes</u> : The following features should be considered when calculating Rear GAWR: Rear Axles; Rear Suspension; Brake System; Brakes, Rear Air Cam; Brake Shoes, Rear; Special Rating, GAWR; Wheels; Tires.	0/792	792	(\$196.15)
14WAL	SUSPENSION/REAR-AXLE IDENTITY for Meritor Tandem Rear Axles With Bar-Pin Beam Attachment Type Suspensions	0/0	0	\$171.10
14WMK	AXLE, REAR, LUBE {EmGard FE-75W-90} Synthetic Oil; 65 thru 89.99 Pints	0/0	0	\$419.68
15DYP	DEF TANK 9.5 U.S. Gal. 36.0L Capacity, Frame Mounted Outside Left Rail, Under Cab	0/0	0	\$0.00
15LKU	FUEL/WATER SEPARATOR {Racor} Fuel Pre-Filter and Filter Base, Includes Water-In-Fuel Sensor	0/0	0	\$0.00
15SJR	FUEL TANK Top Draw; Non-Polished Aluminum, 26" Diam., 100 U.S. Gal., 378 L Capacity Mounted Left Side Under Cab	26/12	38	\$237.40
16031	CAB Conventional <u>Includes</u> : COAT HOOK, CAB Located on Rear Wall, Behind Passenger Seat : CONSOLE, CENTER Plastic, Driver Convenience with a Cup and Change Holder, Ash Tray and Lower Storage Area : DOME LIGHT, CAB (2) Driver and Passenger Dome Lights with Individual Switches, in Headliner : DOOR CHECK STRAP (2) One Each Door : GLASS, ALL WINDOWS Tinted : GRAB HANDLE, CAB INTERIOR (1) "A" Pillar Mounted, Passenger Side : GRAB HANDLE, EXTERIOR (2) Mounted Behind Driver and Passenger Doors : INTERIOR SHEET METAL Upper Door (Above Window Ledge) Painted Exterior Color : SKIN Riveted : STEP (4) Two Steps Per Door	0/0	0	\$0.00
16HBA	GAUGE CLUSTER English With English Electronic Speedometer	0/0	0	\$0.00
16HGL	GAUGE, OIL TEMP, REAR AXLE	0/0	0	\$163.40
16HKB	GAUGE, MANIFOLD PRESSURE Data Link Driven; Mounted in Instrument Panel, Includes Controller Module	0/0	0	\$83.42
16JPC	SEAT, DRIVER {National 2000 Model 295} Air Suspension, Intermediate Back, All Vinyl, 2 Arm Rests, Isolator, 7" Adjuster, 1 Chamber Lumbar, 2 Position Front Cushion Adjust, 3 Position Rear Cushion, 2-15 Degree Back Angle Adjust, Vinyl Suspension Cover	0/0	0	\$0.00



2016-023
TWO (2) CT660S-TRUCK (PCT 3)

Vehicle Specifications

November 22, 2015

2017 CT660S SBA 6x4 (CF7AA)

<u>Code</u>	<u>Description</u>	<u>F/R Wt</u> (lbs)	<u>Tot Wt</u> (lbs)	<u>List</u> (US DOLLAR)
16RAC	SEAT, PASSENGER {National 2000 Model 292} Non Suspension, Intermediate Back, All Vinyl, 11 Degree Back Angle Adjustment	32/4	36	\$484.65
16SKU	MIRRORS (2) {Lang Mekra} Aero; Rectangular, Power Both Sides, Thermostatically Controlled Heated Heads, Amber Lens Clearance Light LED, Black Painted Finish Heads, Brackets & Arms, Breakaway Type, 7.09" x 15.75" & Integral Convex Both Sides, 102" Inside Spacing	-1/0	-1	\$43.00
16VRT	HEATER, ENHANCED CIRCULATION {Bergstrom} Control, for Extreme Cold Weather Climates	0/0	0	\$0.00
16VTH	CAB INTERIOR TRIM Premium Level; for Caterpillar, Day Cab <u>Includes</u> : "A" PILLAR COVER Molded Plastic : CAB INTERIOR TRIM PANELS Vinyl : CONSOLE, OVERHEAD Molded Plastic with Three Storage Pockets; One with Strap for CB Radio Mounting; Two with Netting, Courtesy Lights with Switches : COURTESY LIGHT (2) Driver and Passenger Door Mounted : DOOR TRIM PANELS Vinyl Upper with Power Locks and Windows, Upper and Lower Grab Handles, Both Sides : FLOOR COVERING Rubber, Black : HEADLINER Soft Padded Vinyl : HEATER BOX Metal, Painted Black : INSTRUMENT PANEL TRIM Vinyl : MIRROR, CONVEX, LOOK DOWN Black Finish; 6" x 10-1/4"; Located on Passenger Side : STORAGE POCKET, DOOR (2) Driver and Passenger Door : SUN VISOR (2) Vinyl with Molded Toll Ticket Retainer	0/0	0	\$0.00
16VZA	WINDOW, REAR 52.25" Wide	0/0	0	\$0.00
16WAK	WINDOW, POWER (2) in Left and Right Doors	0/0	0	\$0.00
16WJG	CAB DOOR LOCKS Power	0/0	0	\$0.00
16WKB	AIR CONDITIONER {International Blend-Air} With Integral Heater & Defroster	0/0	0	\$0.00
16WKR	WINDSHIELD Single Piece	0/0	0	\$0.00
16WLD	CAB REAR SUSPENSION {Link Z9079D1} Dual Frame Mounted Cab Rear Air Suspension; Includes Special Crossmember Assembly	0/0	0	\$0.00
16XWD	SUNSHADE, EXTERIOR Aerodynamic, Painted Roof Color; Includes Integral Clearance/Marker Lights	0/0	0	\$0.00
16ZDU	GRAB HANDLE Exterior; Towel Bar Type In Lieu Of Non-Bright Grab Handles; for use with Cab or Cab/Sleeper Non-Bright Access, Without Frame Access or Chassis Skirts	2/0	2	\$29.03
27DNP	WHEELS, FRONT DISC; 22.5" Painted Steel, 10-Stud (285.75MM BC) Hub Piloted, 5-Hand Hole, Flanged Nut, Metric Mount, 12.25 DC Rims; With Steel Hubs, with 5.375" Offset <u>Includes</u> : PAINT IDENTITY, FRONT WHEELS White	100/0	100	\$588.24



2016-023
TWO (2) CT660S-TRUCK (PCT 3)
Vehicle Specifications

November 22, 2015

2017 CT660S SBA 6x4 (CF7AA)

<u>Code</u>	<u>Description</u>	<u>F/R Wt</u> (lbs)	<u>Tot Wt</u> (lbs)	<u>List</u> (US DOLLAR)
28DRN	WHEELS, REAR {Accuride} DUAL DISC; 22.5" Painted Steel, 5-Hand Hole, 10-Stud (285.75MM BC) Hub Piloted, Flanged Nut, Metric Mount, 8.25 DC Rims; With .472" Thick Increased Capacity Disc and Steel Hubs <u>Includes</u> : PAINT IDENTITY, REAR WHEELS White	0/58	58	\$397.32
29WLA	WHEEL BEARING, FRONT, LUBE {EmGard 50W} Synthetic Oil	0/0	0	\$21.50
7482133264	(8) TIRE, REAR 11R22.5 XDN2 (MICHELIN) 497 rev/mile, load range H, 16 ply	0/80	80	\$3,133.52
7652663208	(2) TIRE, FRONT 425/65R22.5 XZY-3 (MICHELIN) 465 rev/mile, load range L, 20 ply	178/0	178	\$452.06
Total of Product Features				\$168,889.20
Total Component Weight:		10289/8689	18978	
Total List Price Including Options:				\$168,889.20

The weight calculations included in this proposal are an estimate of future vehicle weight. The actual weight as manufactured may be different from the estimated weight. Neither Caterpillar nor its suppliers shall be liable for any consequences resulting from any differences between the estimated weight of a vehicle and the actual weight.



2016-023
TWO (2) CT660S-TRUCK (PCT 3)

Electronic Parameters Summary

November 22, 2015

2017 CT660S SBA 6x4 (CF7AA)
ENGINE, DIESEL (0012KXN)

ATTACHMENTS: 0016HBA (GAUGE CLUSTER) 0015LKU (FUEL/WATER SEPARATOR) 0012WEG (COLD STARTING EQUIPMENT) 0012THT (FAN DRIVE)

<u>Parameter</u>	<u>Value</u>	<u>UOM</u>
Max Accelerator Vehicle Speed:7902	75	MPH
Vehicle Speed Limiter Override:7911	0, DISABLE FEATURE OR FUNCTION	N/A
VSLO Speed Increment:7912	10	MPH
VSLO Maximum Activation Time:7914	30	MIN
VSLO Time Interval to Reset:7915	8.0	HOURS
VSLO Time Duration Source:7934	1, INTERVAL BASED ON REAL TIME CLOCK	N/A
Progressive Shift Enable:7744	0, DISABLE FEATURE OR FUNCTION	N/A
Low Gear Ratio Break Point:7742	5.435000	N/A
High Gear Ratio Break Point:7743	1.595000000	N/A
Low Gear Engine Speed Limit:7738	1550.0	RPM
High Gear Engine Speed Limit:7739	1600.0	RPM
Low Gear Engine Speed Range:7740	200.0	RPM
High Gear Engine Speed Range:7741	200.0	RPM
Min Gear Ratio for ProShift:7755	0.50	N/A
Gear Down Protection Enable:7714	0, DISABLE FEATURE OR FUNCTION	N/A
Top Gr Minus 2 Light Ld VS Lim:7715	36	MPH
Top Gr Minus 1 Light Ld VS Lim:7716	48	MPH
Top Gr Minus 2 Heavy Ld VS Lim:7735	39	MPH
Top Gr Minus 1 Heavy Ld VS Lim:7736	54	MPH
Driver Reward Enable:7918	0, DISABLE FEATURE OR FUNCTION	N/A
Driver Reward Mode:7930	2, BOTH ACCELERATOR AND CRUISE VEHICLE SPEED LIMIT INCREASE	N/A
Driver Reward Performance Crit:7925	0, FUEL ECONOMY BASED REWARD SYSEM	N/A
Fuel Economy - Expected Level:7921	6.00	MPG
Fuel Economy - Good Level:7920	6.25	MPG
Fuel Economy - Excellent Level:7919	6.40	MPG
% Idle Time - Expected Level:7924	25	%
% Idle Time - Good Level:7923	18	%
% Idle Time - Excellent Level:7922	10	%
Driver Reward Ambient Temp H:7938	150.0	C
Driver Reward Ambient Temp L:7939	-40.0	C
VS Lim Increase - Expected Lvl:7926	0	MPH
VS Lim Increase - Good Lvl:7927	2	MPH
VS Lim Increase - Excel Lvl:7928	4	MPH
VS Lim Decrease - Penalty Lvl:7929	-2	MPH
Idle Engine Speed:8202	600.0	RPM
Idle Speed Adjustment Enable:8215	1, ENABLE FEATURE OR FUNCTION	N/A
Idle Spd Adjust - Max Eng Spd:8212	0.0	RPM
Idle Spd Adjust - Bump Step:8216	5.0	RPM
Idle Spd Adjust Ramp Rate:8211	25	RPM/SEC
Maximum Standstill Eng Speed:7753	2100.0	RPM
Idle Shutdown Mode:7400	0, DISABLE FEATURE OR FUNCTION	N/A
ISD Time w/Park Brk Released:7401	15.0	MIN
ISD Time w/Park Brake Set:7404	5.0	MIN
ISD Latched Driver Override En:7407	0, DISABLE FEATURE OR FUNCTION	N/A
ISD Ambient Temp Override En:7408	0, DISABLE FEATURE OR FUNCTION	N/A
ISD Int Amb Temp Enable:7405	0, DISABLE FEATURE OR FUNCTION	N/A
ISD Max Ambient Temp Override:7402	20.0	C
ISD Int Amb Temp Override:7406	15.0	C
ISD Min Ambient Temp Override:7403	5.0	C
ISD Max Engine Coolant Temp:7412	150.0	C
ISD Min Engine Coolant Temp:7413	16.0	C
ISD Idle Shutdown Max Eng Trq:7409	80	%
Cruise Control Enable:7600	1, ENABLE FEATURE OR FUNCTION	N/A



2016-023
TWO (2) CT660S-TRUCK (PCT 3)

Electronic Parameters Summary

November 22, 2015

2017 CT660S SBA 6x4 (CF7AA)

CC Max Vehicle Speed:7604	75	MPH
CC Min Vehicle Speed:7603	25.0000	MPH
AESC Control:7500	0, DISABLE FEATURE OR FUNCTION	N/A
AESC In-cab Mode:7502	2, VARIABLE ENGINE SPEED CONTROL SELECTED	N/A
AESC Min Engine Speed:7522	600.0	RPM
AESC Max Engine Speed:7508	1500.0	RPM
AESC Preset Engine Speed 1:7505	800.0	RPM
AESC Preset Engine Speed 2:7506	900.0	RPM
AESC Preset Engine Speed 3:7514	1000.0	RPM
AESC Preset Engine Speed 4:7515	1100.0	RPM
AESC Preset Engine Speed 5:7516	1200.0	RPM
AESC Preset Engine Speed 6:7517	1300.0	RPM
AESC Activate at Preset Speed:7528	0, NO PRESET PRESELECTION	N/A
AESC Ramp Up Rate:7507	100.00	RPM/SEC
AESC Ramp Down Rate:7524	100.00	RPM/SEC
AESC Bump Up/Down Step:7525	25.0	RPM
AESC In-cab Operator Interface:7503	0, NO (OFF) OR DISABLE	N/A
AESC Disable w/ Clutch Pedal:7510	1, ENABLE FEATURE OR FUNCTION	N/A
AESC Disable w/ Brake Pedal:7511	1, ENABLE FEATURE OR FUNCTION	N/A
AESC Accel Pedal Mode:7513	1, AESC OVERRIDDEN BY ACCELERATOR PEDAL	N/A
AESC Max Engine Load:7519	100.0000	%
AESC Control to Engine Load:7530	0, KICK OUT OF AESC ABOVE PROGRAMMED LIMIT	N/A
AESC Max Engine Load Time:7527	8	SEC
AESC Vehicle Speed Limit:7521	5.0000	MPH
AESC Max Mobile Veh Spd:7501	5	MPH
AESC Eng Spd Limit w/VSS Fault:7518	1500	RPM
AESC Force Fan On:9007	0, DISABLE FEATURE OR FUNCTION	N/A
AESC Park Brake Override:7534	1, ENABLE FEATURE OR FUNCTION	N/A
AESC Transfer Case Signal Mode:8910	0, DRIVELINE	N/A
AESC Splitshaft Veh SPD Dsply:9307	0, SPEED SENSOR LOCATED IN WHEEL RIM	N/A
AESC Remote Accel Pedal Enable:7504	0, DISABLE FEATURE OR FUNCTION	N/A
AESC Remote Accel Pedal Switch:8914	0, DISABLE FEATURE OR FUNCTION	N/A
AESC Accel Max Eng Spd Ovr:7520	1900.0	RPM
Rem Accelerator Switch Input:9929	1, SAE J1939 MULTIPLEXED	N/A
Preset Remote AESC Input Type:9932	0, DISCRETE (HARDWIRED) INPUT	N/A
Variable Remote AESC Input:9933	0, DISCRETE (HARDWIRED) INPUT	N/A
Rem Accelerator Position Input:9935	1, SAE J1939 MULTIPLEXED	N/A
Engine Protection Mode:7700	2, TWO WAY SHUTDOWN (OIL PRES, WATER TEMP)	N/A
Powertrain Protection Enable:7722	0, DISABLE FEATURE OR FUNCTION	N/A
Max Torque w/o Vehicle Speed:7712	1450.0000	LB-FT
Highest Gear of Low Range:7718	2	N/A
Highest Gear Rat of Low Range:7745	6.00	N/A
Highest Gear of Int. Range:7748	4	N/A
Highest Gear Rat of Int. Range:7746	4.00	N/A
Highest Gear of High Range:7749	6	N/A
Highest Gear Rat of High Range:7747	2.00	N/A
Max Torque in Low Gear Range:7713	1450.0000	LB-FT
Max Torque in Int. Gear Range:7750	1450.0000	LB-FT
Max Torque in High Gear Range:7751	1450.0000	LB-FT
VSS Anti-Tamper Max Eng Speed:7901	1212.2	RPM
Auxillary Shutdown Input Type:9931	0, DISCRETE (HARDWIRED) INPUT	N/A
Veh Speed Sensor Antitampering:7905	0, DISABLE FEATURE OR FUNCTION	N/A
Veh Overspd Threshold Level 1:7723	73.000000	MPH
Veh Overspd Threshold Level 2:7724	75.000000	MPH
Service Interval Enable	0, DISABLE FEATURE OR FUNCTION	N/A
Fuel Used Service Interval:9501	0	GALLONS
Engine Hour Service Interval:9502	0	HOURS
Veh Distance Service Interval:9503	0	MILES
Service Soon Percent to Notify:9507	90	%



2016-023
TWO (2) CT660S-TRUCK (PCT 3)
Electronic Parameters Summary

November 22, 2015

2017 CT660S SBA 6x4 (CF7AA)

Customer Unit Number:6605	0	N/A
Hard Braking Incident Counter:8904	1, ENABLE FEATURE OR FUNCTION	N/A
Hard Braking Decel Threshold:8905	7.40	MPH/SEC
Vehicle Over-speed Indicator:7754	0, FEATURE OR FUNCTION IS DISABLED	N/A
Customer Password:8700	00000000	N/A

These Electronic Parameters have been successfully finalized



2017 CT660S SBA 6x4 (CF7AA)
 ENGINE/TRANSMISSION MATCHING

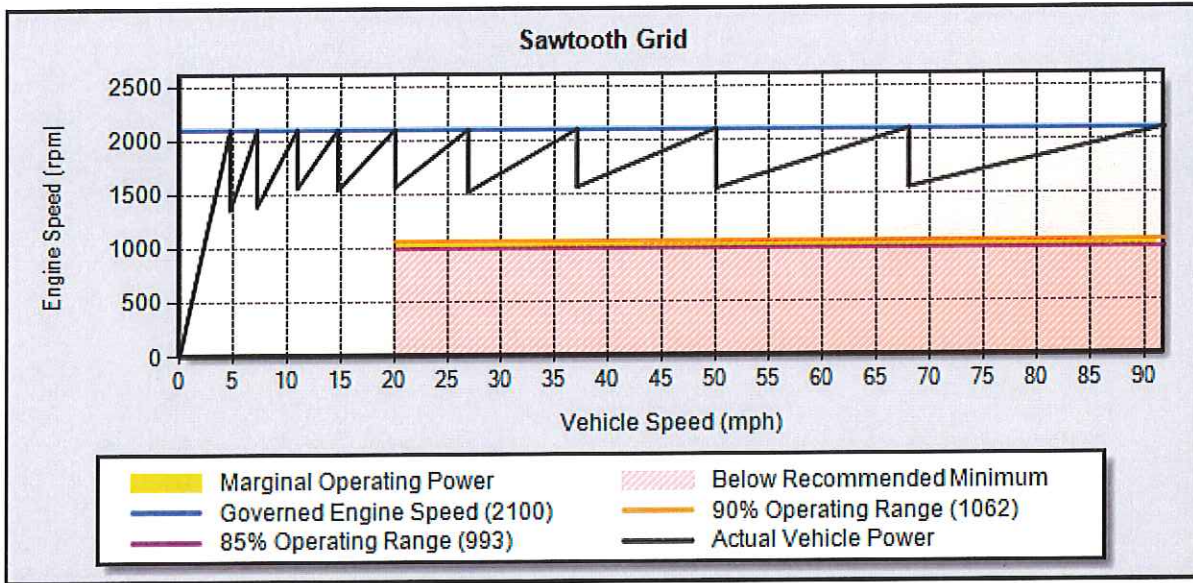

Sawtooth Details

Gear	Trans Ratio	Upshift Power Avail		Govern Power Avail		Peak Power Comparison			Warn Msg
		Veh Spd (MPH)	Eng Spd (RPM)	Veh Spd (MPH)	Eng Spd (RPM)	Gear Step (%)	85% Range (%)	90% Range (%)	
1	14.56	0.0	0	4.7	2100	54.56	111	98	
2	9.42	4.7	1359	7.2	2100	50.96	111	98	
3	6.24	7.2	1391	10.9	2100	34.77	111	98	
4	4.63	10.9	1558	14.7	2100	36.18	111	98	
5	3.40	14.7	1542	20.0	2100	34.39	111	98	
6	2.53	20.0	1563	26.9	2100	38.25	111	98	
7	1.83	26.9	1519	37.1	2100	34.56	111	98	
8	1.36	37.1	1561	50.0	2100	36.00	111	98	
9	1.00	50.0	1544	68.0	2100	35.14	111	98	
10	0.74	68.0	1554	91.8	2100	0.00	111	98	

2016-023
TWO (2) CT660S-TRUCK (PCT 3)



Performance TCAPE Summary

November 22, 2015

2017 CT660S SBA 6x4 (CF7AA)
STEADY STATE PERFORMANCE

Performance Results	Gear	Veh Spd (mph)	Eng Spd (rpm)	Fuel Econ (mpg)	Grade (%)	Notes
LEVEL ROAD MAXIMUM SPEED	10	81.1	1853	4.06	0.00	
HI GEAR SPEED @ RATED RPM	-----	-----	-----	-----	-----	
55.0 MPH STEADY-STATE	10	55.0	1258	6.91	1.64	
TYPICAL OPERATING SPEED	10	68.0	1555	5.42	0.90	- Calculated Grade Ability/Fuel Economy

VEHICLE ORDER CODING ERRORS MAY RESULT IF THE "LEVEL ROAD MAX SPEED" VALUE EXCEEDS THE "HI GEAR SPEED @ RATED RPM" AND IS USED AS THE ENGINE PROGRAMMABLE VEHICLE SPEED LIMIT.

IF THE RESULTS CONTAIN "-----", VEHICLE CANNOT ATTAIN THAT SPEED.

IF THE RESULTS CONTAIN "*****", THE ENGINE USED DOES NOT HAVE A FUEL MAP. FUEL ECONOMY CANNOT BE PREDICTED.

Recommendations / General Information

IDLE FUEL RATE : 0.50 GALS/HR @ 600.0 RPM

Fuel Economy Route: Normal Route - City, Suburban, and Highway

Key Fuel Economy Information	City	Suburban	Highway	Notes
MILES PER GALLON	3.76	5.35	6.21	
AVERAGE MPH	18.5	39.4	54.6	
MISSION MINUTES	30.55	52.57	173.51	

IF THE RESULTS CONTAIN "*****", THE ENGINE USED DOES NOT HAVE A FUEL MAP. FUEL ECONOMY CANNOT BE PREDICTED.



2016-023
TWO (2) CT660S-TRUCK (PCT 3)

Performance TCAPE Summary

November 22, 2015

2017 CT660S SBA 6x4 (CF7AA)
GRADEABILITY PERFORMANCE

Grade Ability Table

Gear	Trans Ratio	Gear Step	Veh Spd (mph)	Eng Spd (rpm)	Whl Pwr (hp)	Grade (%)	Warn Msg	Start Grade (%)	Notes
1	14.56	54.56	1.8	800	105.26	34.83		24.83	- Calculated Start Ability
			2.2	1000	174.42	48.79	@		
			4.7	2100	278.95	35.21			
2	9.42	50.96	2.7	800	106.61	21.80		11.80	
			3.4	1000	244.09	43.16			
			4.7	1359	317.50	40.96			
3	6.24	34.77	7.2	2100	282.34	22.00			
			4.1	800	107.35	14.10		4.10	
			5.2	1000	245.98	27.15			
4	4.63	36.18	7.2	1391	323.38	25.51			
			10.9	2100	284.11	14.20			
			5.6	800	107.65	10.25		0.25	
5	3.40	34.39	7.0	1000	246.85	19.69			
			10.9	1558	338.96	17.17			
			14.7	2100	284.76	10.29			
6	2.53	38.25	9.5	1000	247.38	14.15			
			14.7	1542	338.39	12.40			
			20.0	2100	284.93	7.29			
7	1.83	34.56	12.8	1000	247.59	10.28			
			20.0	1563	340.02	8.87			
			26.9	2100	284.55	5.12			
8	1.36	36.00	26.9	1519	336.30	6.21			
			37.1	2100	283.37	3.27			
			37.1	1561	338.27	4.11			
9	1.00	35.14	50.0	2100	281.25	1.86			
			50.0	1544	339.73	2.52			
			64.7	1998	312.30	1.00			
10	0.74	0.00	67.9	2097	281.79	0.50			
			68.0	2100	280.95	0.49			
			66.6	1522	328.26	1.00			
			68.0	1554	330.37	0.90			
			74.2	1697	337.04	0.50			
			81.2	1855	332.43	0.00			
			91.9	2100	269.05	-1.12			

STARTING / TOP GEAR PERFORMANCE

Gear	Trans Ratio	Gear Step	Veh Spd (mph)	Eng Spd (rpm)	Whl Pwr (hp)	Grade (%)	Warn Msg	Start Grade (%)	Notes
1	14.56	54.56	1.8		105.26	34.83		24.83	- Calculated Start Ability
2	9.42	50.96	2.7		106.61	21.80		11.80	
3	6.24	34.77	4.1		107.35	14.10		4.10	
4	4.63	36.18	5.6		107.65	10.25		0.25	

@ - WHEELSLIP CAN OCCUR AT THE GRADE SHOWN. THE VEHICLE IS CAPABLE OF INCREASED GRADEABILITY IF MORE WEIGHT IS PLACED ON THE DRIVE AXLES.



2016-023
TWO (2) CT660S-TRUCK (PCT 3)

Performance TCAPE Summary

November 22, 2015

2017 CT660S SBA 6x4 (CF7AA)
ACCELERATION PERFORMANCE RESULTS

Acceleration Performance Grid

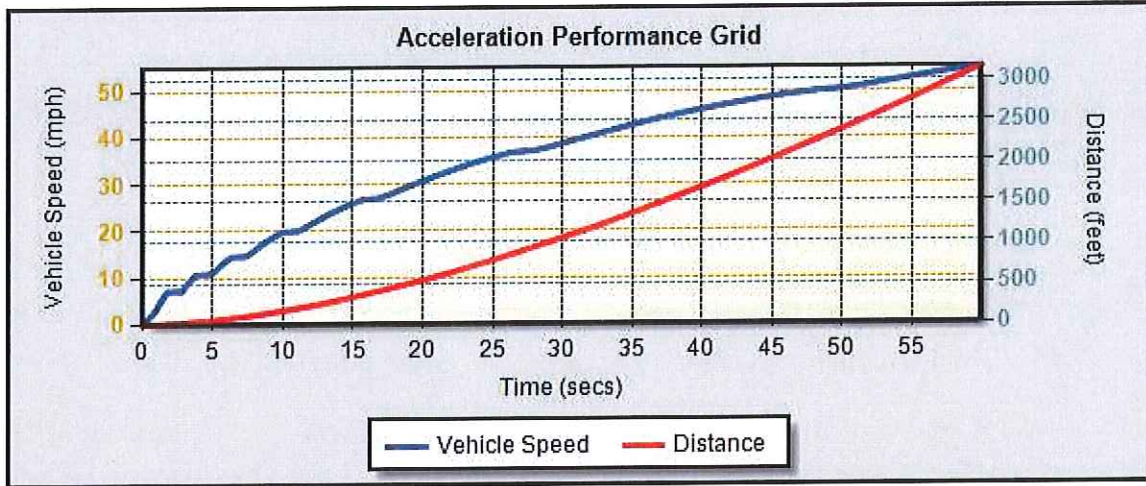

Acceleration Performance: TIME TO ACCELERATE ON A GRADE TO 55.0 (MPH) IS 59.99 (SECS)

Acceleration Performance Details

Gear	Time (secs)	Distance (feet)	Speed (mph)	Notes
2	0.32	0.2	1.0	
	0.65	1.0	2.0	
	0.93	2.0	3.0	
	1.13	3.0	4.0	
	1.31	4.2	5.0	
	1.52	5.9	6.0	
	1.77	8.2	7.0	
	1.83	8.9	7.2	
	2.83	19.4	7.1	
3	3.07	22.0	8.1	
	3.32	25.3	9.1	
	3.62	29.4	10.1	
	3.90	33.8	10.9	
	4.90	49.7	10.7	
4	5.22	54.8	11.7	
	5.56	60.9	12.7	
	5.94	68.3	13.7	
	6.37	77.3	14.7	
	7.37	98.7	14.5	
5	7.78	107.7	15.5	
	8.21	117.8	16.5	
	8.67	129.2	17.5	
	9.17	142.5	18.5	
	9.74	158.5	19.5	
	10.06	167.7	20.0	
6	11.06	196.8	19.8	
	11.61	213.3	20.8	
	12.19	231.3	21.8	
	12.79	250.8	22.8	
	13.42	272.5	23.8	
	14.11	297.0	24.8	
	14.87	325.4	25.8	



2016-023
TWO (2) CT660S-TRUCK (PCT 3)
Performance TCAPE Summary

November 22, 2015

2017 CT660S SBA 6x4 (CF7AA)				
Gear	Time (secs)	Distance (feet)	Speed (mph)	Notes
	15.74	359.0	26.8	
	15.80	361.4	26.9	
	16.80	400.6	26.7	
7	17.57	431.3	27.7	
	18.37	464.2	28.7	
	19.19	499.3	29.7	
	20.04	536.8	30.7	
	20.92	576.9	31.7	
	21.84	620.3	32.7	
	22.82	667.8	33.7	
	23.87	720.8	34.7	
	25.04	780.8	35.7	
	26.33	849.3	36.7	
	27.01	886.4	37.1	
	28.01	940.7	36.9	
8	29.17	1003.9	37.9	
	30.35	1070.8	38.9	
	31.58	1141.5	39.9	
	32.84	1216.2	40.9	
	34.14	1295.2	41.9	
	35.48	1378.8	42.9	
	36.89	1468.4	43.9	
	38.38	1565.6	44.9	
	39.98	1671.9	45.9	
	41.71	1789.8	46.9	
	43.61	1921.8	47.9	
	45.71	2070.9	48.9	
	48.07	2241.6	49.9	
	48.28	2256.7	50.0	
	49.28	2329.8	49.7	
9	51.14	2467.3	50.7	
	53.07	2612.0	51.7	
	55.06	2764.4	52.7	
	57.13	2925.2	53.7	
	59.26	3094.9	54.7	
	59.99	3153.0	55.0	



2016-023
TWO (2) CT660S-TRUCK (PCT 3)
Performance TCAPE Summary

November 22, 2015

2017 CT660S SBA 6x4 (CF7AA)
REQUIRED TCAPE INFORMATION

TCAPE Factors For Vehicle

Selected Rear Axle Gear Ratio(s):	3.73
Vehicle Vocation:	GENERAL ON HIGHWAY
Road Surface Type:	TYPICAL
Enroute PTO:	NO
Fuel Economy Route:	Normal Route - City, Suburban, and Highway
Engine Fan Type:	VISCOUS
ID Wheel Slip Conditions:	Yes
Parked PTO:	NO
Road Governor/Cruise Ctrl:	No
Acceleration Grade (%):	0.0
Alternator (A):	40
Weight on Drive Axle (LBF):	46000
Relative Drag Coefficient:	105
Frontal Area (FT2):	88
Acceleration Start Gear:	2
Air Compressor (HP):	2.20
Acceleration Vehicle Spd (MPH):	55.0
Vehicle Width (IN):	96
Vehicle Height (IN):	132
Steering Gear (HP):	2.60
Air Conditioner (HP):	2.20
Speed Limit on Route (MPH):	61.0
TIRE, FRONT	2 - RADIAL WIDEBASE
TIRE, REAR	8 - RADIAL NORMAL

Components

0002ARY	AXLE, FRONT NON-DRIVING {Meritor MFS-20-133A} Wide Track, I-Beam Type, 20,000-lb Capacity
0004SPM	AIR COMPRESSOR {Bendix BA-921 Head Unload} 15.9 CFM Capacity, Single Cylinder
0005PTB	STEERING GEAR (2) {Sheppard M-100/M-80} Dual Power
0008GGN	ALTERNATOR {Bosch LH160} Brush Type, 12 Volt 160 Amp. Capacity, Pad Mount
0012KXN	ENGINE, DIESEL {CT 13} EPA 2010, SCR, 390 HP @ 1700 RPM, 1450 lb-ft Torque @ 1000 RPM, 2100 RPM Governed Speed, 390 Peak HP (Max)
0012THT	FAN DRIVE {Horton Drivemaster} Direct Drive Type, Two Speed With Residual Torque Device for Disengaged Fan Speed
0013GHW	TRANSMISSION, MANUAL {Fuller RTO(F)-14908LL} 10-Speed Manual; Double Lo With Overdrive and With Air Shift
0014GRR	AXLE, REAR, TANDEM {Meritor RT-46-160P} Single Reduction, 46,000-lb Capacity, With Lube Pump, 200 Wheel Ends
0016031	CAB Conventional
0016WKB	AIR CONDITIONER {International Blend-Air} With Integral Heater & Defroster
0016XWD	SUNSHADE, EXTERIOR Aerodynamic, Painted Roof Color; Includes Integral Clearance/Marker Lights
07482133264	TIRE, REAR 11R22.5 XDN2 (MICHELIN) 497 rev/mile, load range H, 16 ply 11R22.5 XDN2 (MICHELIN) 497 rev/mile, load range H, 16 ply
07652663208	TIRE, FRONT 425/65R22.5 XZY-3 (MICHELIN) 465 rev/mile, load range L, 20 ply 425/65R22.5 XZY-3 (MICHELIN) 465 rev/mile, load range L, 20 ply

TCAPE HAS BEEN DESIGNED TO GIVE ECONOMY AND PERFORMANCE PREDICTIONS WHICH HAVE BEEN SHOWN TO BE TYPICAL FOR MOST OPERATIONS. HOWEVER, DUE TO OPERATING CONDITIONS, DRIVER INFLUENCES, AND OTHER FACTORS, YOUR RESULTS MAY VARY FROM THOSE PREDICTED. ALSO, BECAUSE OF FUEL MAPPING PROCEDURES USED BY VARIOUS ENGINE MANUFACTURERS, COMPARISONS OF FUEL ECONOMY RESULTS FOR DIFFERENT BRANDS OF ENGINES MAY VARY FROM THOSE SHOWN.

NEITHER CATERPILLAR NOR ITS SUPPLIERS SHALL BE LIABLE FOR ANY LOSS OF PROFITS, LOSS OF USE, INTERRUPTION OF BUSINESS OR INDIRECT, SPECIAL, INCIDENTAL OR CONSEQUENTIAL DAMAGES OF ANY KIND THAT ARE INCURRED BY DEALER OR BY DEALER'S CUSTOMERS AS A RESULT OF RELIANCE ON TCAPE, WHETHER THE CLAIM IS IN CONTRACT, TORT (INCLUDING NEGLIGENCE), STRICT LIABILITY OR OTHERWISE.

2016-023
TWO (2) CT660S-TRUCK (PCT 3)

Turning Radius Summary

November 22, 2015



2017 CT660S SBA 6x4 (CF7AA)

Series: CAT
 Model: CF7AA
 Description: CT660S SBA 6x4
 Model Year: 2017

Calculation Factors

Wheelbase: 260
 Front Axle: 0002ARY
 Description: AXLE, FRONT NON-DRIVING, {Meritor MFS-20-133A} Wide Track, I-Beam Type, 20,000-lb Capacity
 Front Wheel: 0027DNP
 Description: WHEELS, FRONT, DISC; 22.5" Painted Steel, 10-Stud (285.75MM BC) Hub Piloted, 5-Hand Hole, Flanged Nut, Metric Mount, 12.25 DC Rims; With Steel Hubs, with 5.375" Offset
 Front Tire: 07652663208
 Description: TIRES, 425/65R22.5 XZY-3 (MICHELIN) 465 rev/mile, load range L, 20 ply
 Steering Gear: 0005PTB
 Description: STEERING GEAR, (2) {Sheppard M-100/M-80} Dual Power

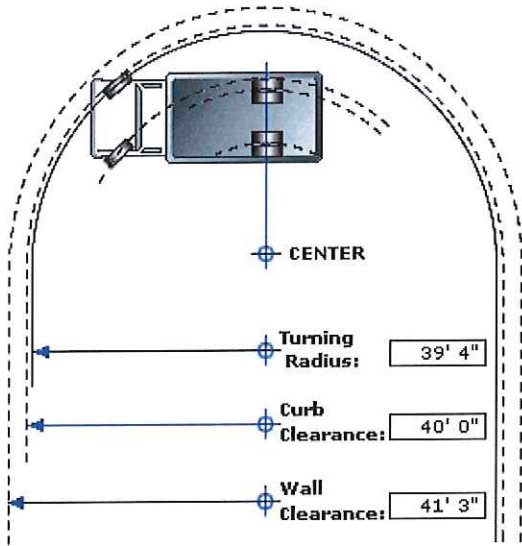

Turning Radius Statistics

General Information

Inside Turn Angle: 40 Degrees
 Radial Overhang: 23

Axle Information

KingPin Inclination: 6.25 Degrees
 KingPin Center: 71

Turning Radius - Curb View

C - Curb Contact Length: 16.92
 CI - Curb Clearance Increment: 8.60
 CR - Curb Clearance Radius: 40'0"
 CH - Curb Height: 6"
 TR - Turning Radius: 39'4"
 TW - Tire Width: 16.60

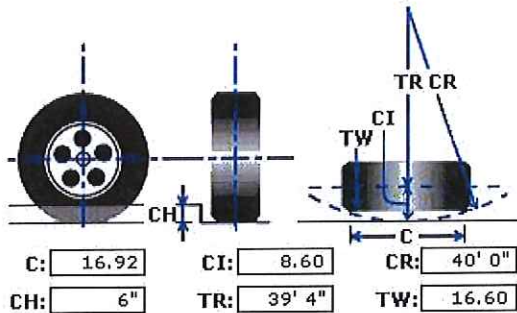

* All Measurements are in inches, unless otherwise specified.

2016-023
TWO (2) CT660S-TRUCK (PCT 3)

Turning Radius Summary

November 22, 2015



2017 CT660S SBA 6x4 (CF7AA)

This information is based on engineering information available at this time. Actual figures may vary. Neither Caterpillar nor its suppliers can accept liability for consequences due to this variance.

ROLL-OFF CABLE HOISTS



Tel: 800.285.0666 | sales@wastequip.com | www.galbreathproducts.com



OUTSIDE RAIL SERIES

Outside Rail (OR) roll-off cable hoists are the most common and versatile hoists in use today.

- » 30,000 to 75,000 lb. capacity
- » Single and tandem axle

OR SERIES

STANDARD FEATURES

Ease of operation

- Centered cab-mount Power Tower
- Plug n' Play wiring system
- Pintle ready rear aprons
- Standard inside air control

Safety

- Automatic front container spring-loaded locking system and rear container hold-downs
- Heavy-duty safety props
- Automatic fold-up ICC bumper
- Backup alarm and hoist-up alarm with signal light on dash
- Optional hoist-up speed-limiting parameters

* Factory mount models

All Galbreath products are designed to be compliant with ANSI standard container requirements.

Durability

- 3 micron filtration system with dual viscosity oil
- Two-part epoxy primer and paint*
- Field-tested heavy-duty rear hinge
- Hoist frames are huck bolted to chassis*
- Shock-absorbing sub-frame
- Oil reservoir is filter-cart-ready
- LED lighting
- Lifetime warranty on frame and two-year warranty on hydraulics

Quality

- Stringent, multi-year product testing, engineering, solid modeling, and stress analysis testing ensure maximum product quality
- Customized engineering layouts based on customers' chassis ensure compatibility

AVAILABLE OPTIONS

- Reverse cylinder mount
- Pintle hook applications
- Various fender selections
- Auxiliary hydraulic hook-ups
- Scale systems
- Pioneer Rack'n Pinion tarping systems

SPECIFICATIONS

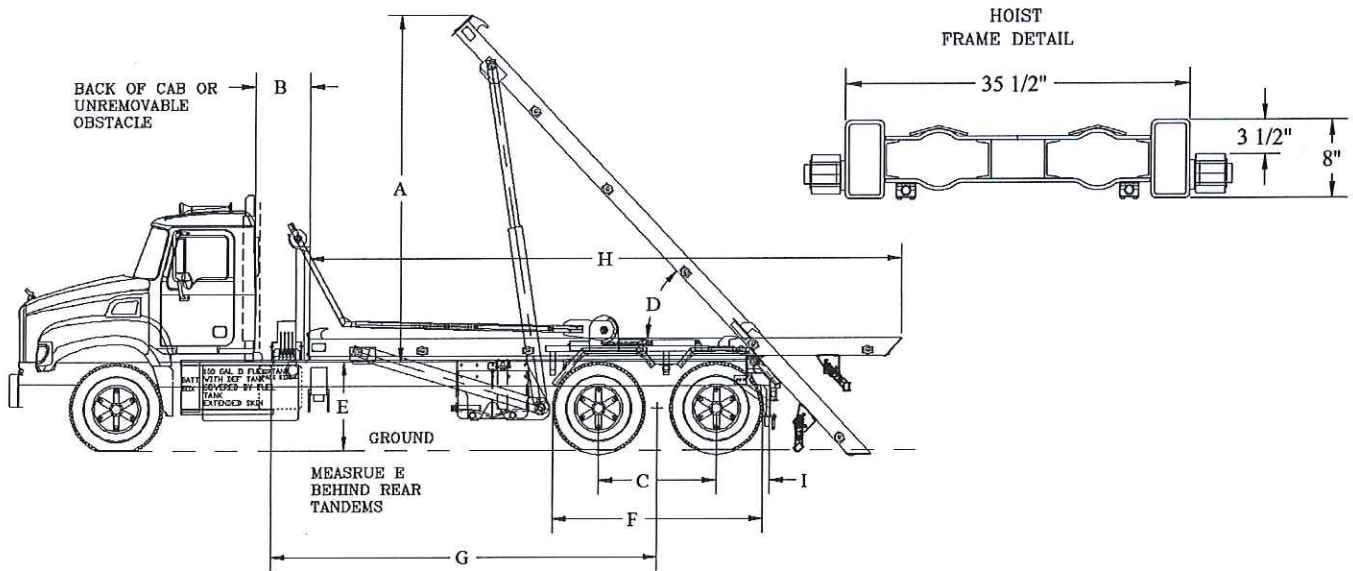

Notes for chart below:

- 1 When recommending container lengths, weight distribution, fender interference and overhang are factors.
- 2 Factory tested with recommended container length and water level load
- 3 Frame = top of truck chassis frame
- 4 This distance does not allow for a behind-the-cab oil reservoir, tarper platform or room to add a tarper. Must add distance for these items.
- 5 Use 22.5" tires only. For larger tires, consult representative.

	U3-OR-156	U5-OR-174	U5-OR-194	UT-OR-174
FEATURE	SINGLE AXLE	TANDEM AXLE	TANDEM AXLE	TANDEM AXLE
Recommended container size ¹	14'-20'	18'-22'	20'-24'	18'-22'
Rated capacity ²	30,000 lbs.	60,000 lbs.	60,000 lbs.	60,000 lbs.
A - Height above truck frame ³	156-3/4"	162-1/2"	180-7/8"	164"
B - Back of cab to hoist ⁴ (add 12" for tarper or hard plumbing)	6"	6"	6"	6"
C - Axle spread	n/a	51-55"	51-55"	51-55"
D - Raised dump angle	51°	47°	48°	48°
E - Top of truck frame to ground ^{3,5}	42"	46"	46"	46"
F - Tire OD to OD	n/a	96" max	96" max	96" max
G - Cab to Trunnion (CT) (add 12" for tarper or hard plumbing)	156"	174"	194"	174"
H - Hoist length	246"	280"	300"	280"
I - After frame Add 2" for air ride	37 1/4"	23"	23"	23"
Lift cylinders DA = double acting DAT = double acting telescopic	5" x 3" x 54" DA	6" x 4" x 72" DA	6" x 5" x 114" DAT	6-5-4" X 118" DAT
Lift cylinders shaft	1-1/2" solid	2-1/2" solid	2-1/2" solid	2-1/2" solid
Winch cylinders DA = double acting	5" x 3" x 66" DA	7" x 4" x 80" DA	7" x 4" x 90" DA	7" x 4" x 80" DA
Approx. weight with standard features	5,900 lbs.	7,562 lbs.	8,206 lbs.	7,791 lbs.

FEATURES	SINGLE AXLE	TANDEM AXLE
Hoist frame	8" x 3" x 3/8" A500 grade C tubing	8" x 4" x 1/2" A500 grade C tubing
Subframe	4" x 3" x 1/4" A500 grade C tubing	3" x 2" x 3/16" A500 grade C tubing
Front stop	1-1/2" plate steel	1-1/2" plate steel
Front safety lock	Automatic spring loaded	Automatic spring loaded
Hinge shaft	1-1/2" solid steel	2-1/2" solid steel
Cable anchors	4 cable clamps	4 cable clamps
Cable end	Pear eye	Swedged end swivel eye
Rear hold downs	1/2" plate located for standard Wastequip containers	3/4" plate located for standard Wastequip containers
Operating pressure	1,850 psi	1,850 psi
Hydraulic pump	Gear type 17.5 gpm @ 1,500 rpm	Gear type 35 gpm @ 1,500 rpm
Hydraulic valve	2 spool / 25 gpm with safety bypass	2 spool / 45 gpm with safety bypass
Oil reservoir	20 gallon with 3 micron filter and fill	50 gallon with 3 micron filter and fill
Outside rollers	4" OD with bronze bearings	4" OD with bronze bearings
Cable sheaves	10" OD with bronze bearings	10" OD with bronze bearings
Working points	Greasable	Greasable
Chassis front axle	9,000 (min.) capacity with power steering	18,000 (min.) capacity with power steering
Chassis rear axle	22,400# capacity (min.)	44,000# capacity (min.)
Frame modulus	50,000 PSI or more chassis frames - minimum section modulus = 17.5 in ³	50,000 PSI or more chassis frames - minimum section modulus = 24 in ³
Torque required	103 foot pounds of torque	248 foot pounds of torque

	UT-OR-194	U75-OR-174	U75-OR-194	UH-OR-174	UH-OR-194
FEATURE	TANDEM AXLE	TANDEM AXLE	TANDEM AXLE	TANDEM AXLE	TANDEM AXLE
Recommended container size ¹	20'-24'	18'-22'	20'-24'	18'-22'	20'-24'
Rated capacity ²	60,000 lbs.	75,000 lbs.	75,000 lbs.	75,000 lbs.	75,000 lbs.
A - Height above truck frame ³	178-3/4"	162-3/8"	178-3/4"	163-5/16"	178-1/2"
B - Back of cab to hoist ⁴ (add 12" for tarper or hard plumbing)	6"	6"	6"	6"	6"
C - Axle spread	51-55"	51-55"	51-55"	51-55"	51-55"
D - Raised dump angle	48°	47°	48°	47°	47°
E - Top of truck frame to ground ^{3,5}	46"	46"	46"	46"	46"
F - Tire OD to OD	96" max	96" max	96" max	96" max	96" max
G - Cab to Trunnion (CT) (add 12" for tarper or hard plumbing)	194"	174"	194"	174"	194"
H - Hoist length	300"	280"	300"	280"	300"
I - After frame Add 2" for air ride	23"	23"	23"	23"	23"
Lift cylinders DA = double acting DAT = double acting telescopic	6-5-4" X 118" DAT	7" x 4" x 72" DA	6-5-4" X 118" DAT	6-5-4" X 118" DAT	6-5-4" X 118" DAT
Lift cylinders shaft	2-1/2" solid	2-1/2" solid	2-1/2" solid	2-1/2" solid	2-1/2" solid
Winch cylinders DA = double acting	7" x 4" x 90" DA	7" x 4" x 80" DA	7" x 4" x 90" DA	7" x 4" x 80" DA	7" x 4" x 90" DA
Approx. weight with standard features	8,068 lbs.	8,242 lbs.	8,886 lbs.	8,471 lbs.	9,115 lbs.

OTHER GALBREATH HOISTS AVAILABLE

IO Series

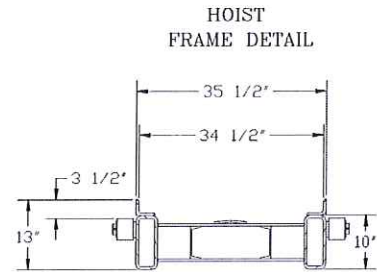
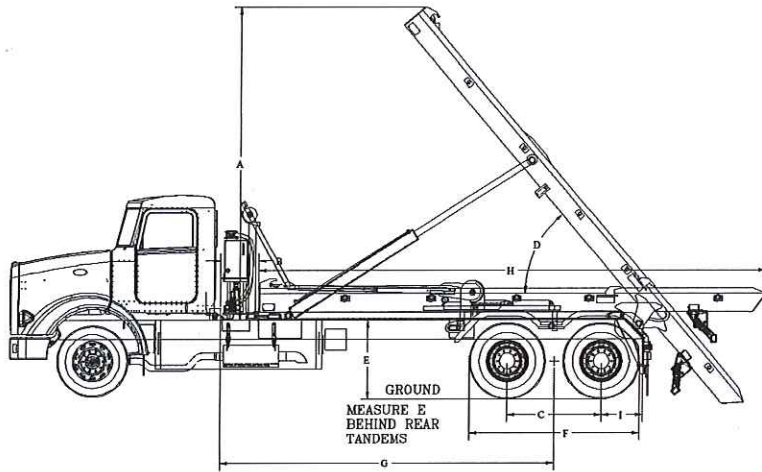

EX Series

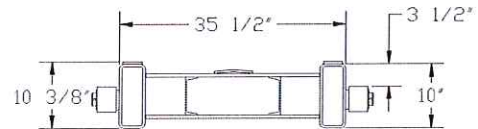
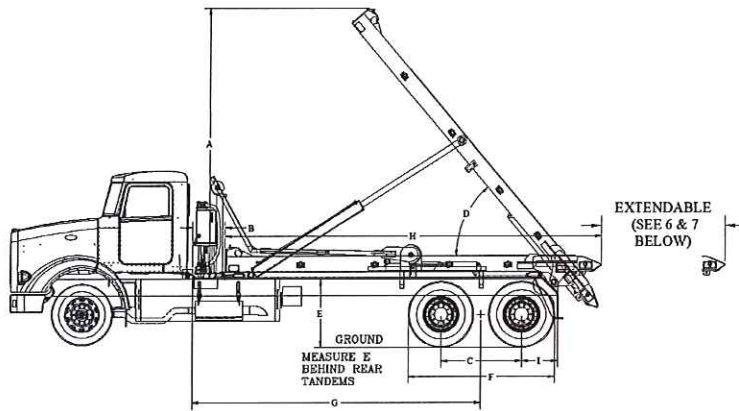

SWIVEL CABLE END

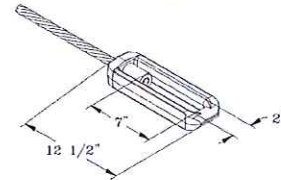

HH Series

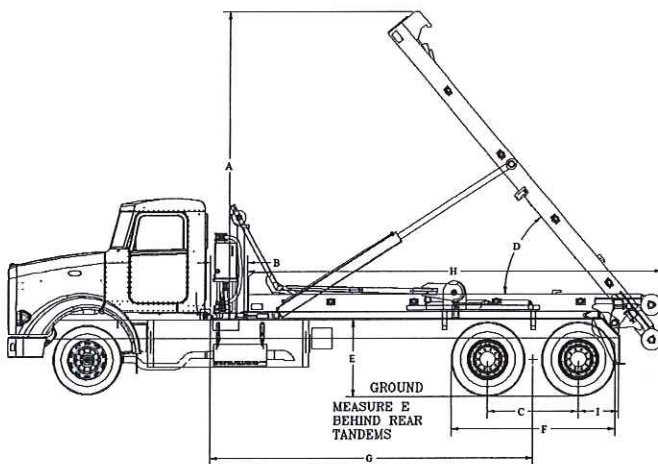

HOIST FRAME DETAIL

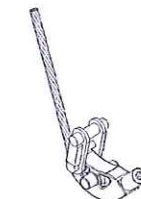
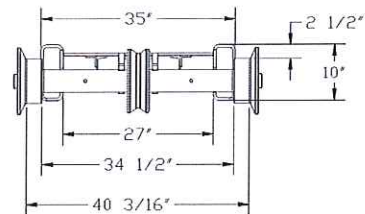

KNUCKLE CABLE END

GALBREATH QUALITY

Standard Features



3 micron filtration system (pictured at right) with dual viscosity oil reduces contamination, required maintenance, and down time.

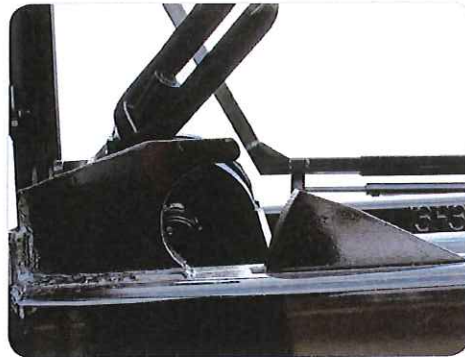

Automatic front container spring-loaded locking system and rear container hold-downs help ensure container remains in place.



"Plug n' Play" wiring system eliminates crossed wires, loose connections, corrosion and splices, and allows for easy light replacement.



Oil reservoir is filter-cart-ready, reducing maintenance costs.

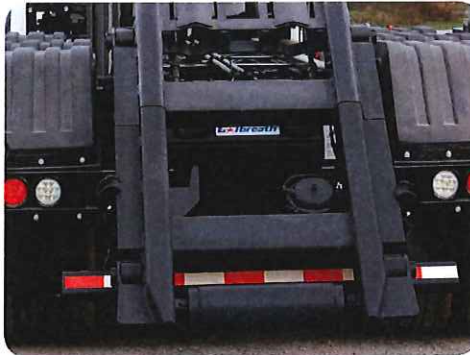

Air assist ICC bumper

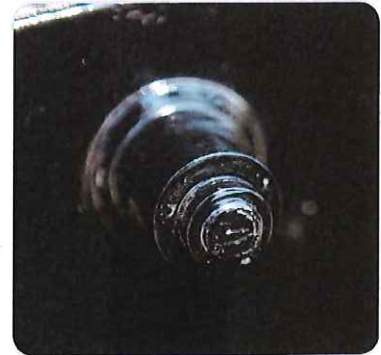

Hoist frames are huck bolted to chassis, providing unmatched strength and durability. (factory mount only)

Available Options



Rear skid plate with outboard supported rollers



Optional rear ratchet straps on all cable models



Pintle ready rear aprons allow for the addition of a pintle hook and easy upgrade to a trailer package.

AVAILABLE OPTIONS

- Reverse cylinder mount
- Pintle hook applications
- Various fender selections
- Auxiliary hydraulic hook-ups
- Scale systems
- Pioneer Rack 'n Pinion tarping systems

TRUCK SPECIFICATIONS

Single axle:

- Front axle: 9,000 lbs. (min.) capacity
- Rear axle: 22,400 lbs. (min.) capacity
- 50,000 psi or more chassis frames
- Minimum section modulus = 17.5 in.³

Tandem axle:

- Front axle: 18,000 lbs. (min.) capacity
- Rear axle: 44,000 lbs. (min.) capacity
- 50,000 psi or more chassis frames
- Minimum section modulus = 24 in.³

CONTAINER REQUIREMENTS

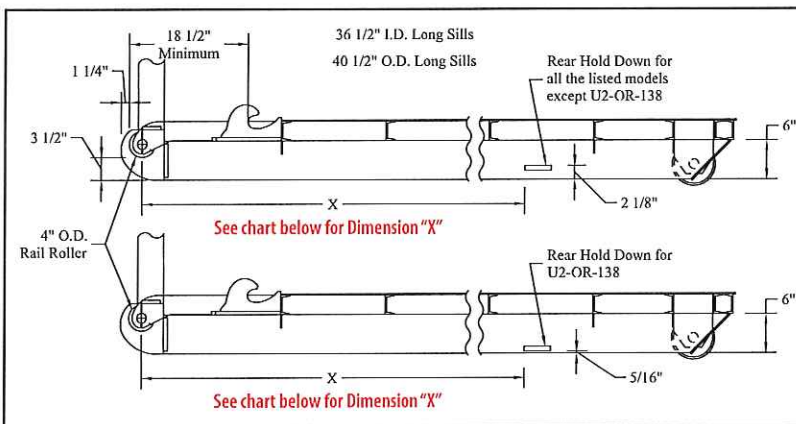

All Galbreath products are designed to be compliant with ANSI standard container requirements.

DIMENSION "X"*

CONTAINER LENGTHS

MODEL	12 ft.	13 ft.	14 ft.	15 ft.	16 ft.	17 ft.	18 ft.	19 ft. +
All (except U2-EX/IO/OR-138 & U3-EX/IO/OR-156)	Additional info. needed	145-1/2"	145-1/2"	149"	149"	173"	173"	191"
U2-EX/IO/OR-138	Length not recommended	Length not recommended	158"	158"	158"	158"	158"	Length not recommended
U3-EX/IO/OR-156	Length not recommended	Length not recommended	149"	173"	173"	173"	173"	173"

* Dimension "X" is center of rail roller to front of rear hold-down

NOTE: Tolerance for all models is +1" / -0" except where container lengths are not recommended or where more information is required.



Tel: 800.285.0666 | sales@wastequip.com | www.galbreathproducts.com

Wastequip is the leading North American manufacturer of waste and recycling equipment for collecting, processing and transporting recyclables and solid or liquid waste. © January 2015 Wastequip, all rights reserved. Specifications subject to improvement without notice. Equipment displayed should be operated by properly trained personnel. Operators should become familiar with OSHA, ANSI and any other applicable standards or laws for using this equipment. Improper use, misuse, or lack of maintenance could cause injury to people and/or property. Photos used in the literature are illustrative only. We assume no liability or responsibility for proper training/operation of equipment not manufactured by Wastequip. We reserve the right to make changes at any time without notice. Information contained within this literature is intended to be the most accurate available at time of printing.

2016-023 2 CT660S TRUCK (PCT 3)

Form **8038-G**
(Rev. November 2000)
Department of the Treasury
Internal Revenue Service

Information Return for Tax-Exempt Governmental Obligations

► Under Internal Revenue Code section 149(e)
► See separate instructions.

OMB No. 1545-0720

Caution: If the issue price is under \$100,000, use Form 8038-GC.

Part I Reporting Authority			If Amended Return, check here <input type="checkbox"/>	
1 Issuer's name			2 Issuer's employer identification number	
3 Number and street (or P.O. box if mail is not delivered to street address)	Room/suite	4 Report number		
5 City, town, or post office, state, and ZIP code		3		
7 Name of issue		6 Date of issue		
9 Name and title of officer or legal representative whom the IRS may call for more information		8 CUSIP number		
		10 Telephone number of officer or legal representative ()		

Part II Type of Issue (check applicable box(es) and enter the issue price) See instructions and attach schedule	
11 <input type="checkbox"/> Education	11
12 <input type="checkbox"/> Health and hospital	12
13 <input type="checkbox"/> Transportation	13
14 <input type="checkbox"/> Public safety	14
15 <input type="checkbox"/> Environment (including sewage bonds)	15
16 <input type="checkbox"/> Housing	16
17 <input type="checkbox"/> Utilities	17
18 <input type="checkbox"/> Other. Describe ►	18
19 If obligations are TANs or RANs, check box <input type="checkbox"/> If obligations are BANs, check box <input type="checkbox"/>	
20 If obligations are in the form of a lease or installment sale, check box <input type="checkbox"/>	

Part III Description of Obligations. Complete for the entire issue for which this form is being filed.				
(a) Final maturity date	(b) Issue price	(c) Stated redemption price at maturity	(d) Weighted average maturity	(e) Yield
21	\$	\$	years	%

Part IV Uses of Proceeds of Bond Issue (including underwriters' discount)	
22 Proceeds used for accrued interest	22
23 Issue price of entire issue (enter amount from line 21, column (b))	23
24 Proceeds used for bond issuance costs (including underwriters' discount)	24
25 Proceeds used for credit enhancement	25
26 Proceeds allocated to reasonably required reserve or replacement fund	26
27 Proceeds used to currently refund prior issues	27
28 Proceeds used to advance refund prior issues	28
29 Total (add lines 24 through 28)	29
30 Nonrefunding proceeds of the issue (subtract line 29 from line 23 and enter amount here)	30

Part V Description of Refunded Bonds (Complete this part only for refunding bonds.)	
31 Enter the remaining weighted average maturity of the bonds to be currently refunded	_____ years
32 Enter the remaining weighted average maturity of the bonds to be advance refunded	_____ years
33 Enter the last date on which the refunded bonds will be called	_____
34 Enter the date(s) the refunded bonds were issued	_____

Part VI Miscellaneous	
35 Enter the amount of the state volume cap allocated to the issue under section 141(b)(5)	35
36a Enter the amount of gross proceeds invested or to be invested in a guaranteed investment contract (see instructions)	36a
b Enter the final maturity date of the guaranteed investment contract	37a
37 Pooled financings: a Proceeds of this issue that are to be used to make loans to other governmental units	
b If this issue is a loan made from the proceeds of another tax-exempt issue, check box <input type="checkbox"/> and enter the name of the issuer	
38 If the issuer has designated the issue under section 265(b)(3)(B)(i)(III) (small issuer exception), check box <input type="checkbox"/>	
39 If the issuer has elected to pay a penalty in lieu of arbitrage rebate, check box <input type="checkbox"/>	
40 If the issuer has identified a hedge, check box <input type="checkbox"/>	

Under penalties of perjury, I declare that I have examined this return and accompanying schedules and statements, and to the best of my knowledge and belief, they are true, correct, and complete.

Sign Here

Signature of issuer's authorized representative _____ Date _____ Type or print name and title _____



2016-023
Two (2) CT6605-Truck
Pct 3

B & C BODY COMPANY
P.O. BOX 2867
LONGVIEW, TX 75606

DATE: November 21, 2015
CUSTOMER NAME: HOLT CAT
ADDRESS:
CITY/STATE/ZIP: EDINBURG, TX
ATTN: MARK
SALESMAN: JIM LEWIS

QUOTE # jfl151016-8

	DESCRIPTION	AMOUNT
1ea.	Galbreath U5-OR-174 , 60,000# Capacity Roll-Off Hoist W/ Outside Rails, Capable Of Loading 22ft. Containers, W/ Inside Air Controls, 5 Spool Outside Manual Control Valve, 48" Steel Tool Box, Tandem Tread Plate Fenders, Tarper Platform w/ Control Valve Cover, Approach Ramps w/ Ratchet Hold Straps, Hard Plumbing, Air Assist ICC Bumper, Air shift PWO w/ Direct mount pump, Huck Bolt Mounted & Painted Black w/ Decals & Reflective Tape.	\$ 36,400.00
1ea.	Pioneer Rack & Pinion RP4500 SARG Adjustable Gantry Tarper Painted Black	
	Freight from Durant, OK to Edinburg, TX	1,250.00

TRUCK MUST HAVE A CLEAR CT OF 186 " BOTH TOP & SIDE RAILS

PAYMENT DUE UPON RECEIPT
PLEASE REMIT PAYMENT TO THE ABOVE ADDRESS

FOB : DURANT , OK.

FEDERAL EXCISE TAX

NOT INCLUDED

SUBTOTAL

37,650.00

STATE SALES TAX

LICENSE & REGISTRATION

TITLE FEE/COUNTY ROAD/BRIDGE

TOTAL PRICE

37,650.00

DEPOSIT ON ORDER

CASH ON DELIVERY

37,650.00

AMOUNT FINANCED

TOTAL PRICE

\$ 37,650.00

CUSTOMER ACKNOWLEDGEMENT _____

CUSTOMER SIGNATURE _____

Zimbra

elena.gomez@co.hidalgo.tx.us

RE: 2016-023 Purchase of 2

From : Victor M. Garza <victor.garza@da.co.hidalgo.tx.us>

Mon, Dec 21, 2015 10:46 AM

Subject : RE: 2016-023 Purchase of 2**To** : 'Elena Gomez' <elena.gomez@co.hidalgo.tx.us>**Cc** : 'Josephine Ramirez Solis'
<josephine.ramirez@da.co.hidalgo.tx.us>**Reply To** : victor garza <victor.garza@da.co.hidalgo.tx.us>

Ms. Gomez,

Our office reviewed the proposed Equipment Lease-Purchase Agreement No. 2758156 between Caterpillar Financial Services Corporation and Hidalgo County. At this time our office approves as to the form of the agreement, specifically the terms and conditions, and the attached amendment to section 7.

Please provide Caterpillar the Commissioners Court posted Notice of Agenda (confirming compliance with the open meetings law), Agenda minutes demonstrating the Commissioners Court action in approving the agreement and authorizing the County Judge to sign on behalf of the County, as well as any other backup information related to this agenda item as you deem necessary.

In addition, our office would recommend striking or removing the Resolution and Opinion of Counsel. However, you may want to include a Certificate of the County as it relates to a requested tax exempt status.

Please let me know if you have any other questions or concerns.

Victor M. Garza
Assistant District Attorney
Civil Division
Office of the Criminal District Attorney
Hidalgo County, Texas
100 N. Closner RM 303

Thank you for selecting Caterpillar products and for allowing Caterpillar Financial Services Corporation to serve your financing needs. Included in this document package are all of the forms that will be needed for standard tax exempt lease purchase transactions. The forms have been designed to be clear, concise and user friendly. We have also provided a brief explanation of the purpose of each form. If you wish to discuss any of the forms or have any questions about any aspect of this transaction, we encourage you to contact your Caterpillar Dealer or Caterpillar Financial Services Corporation at 1-866-263-3791 Option # 5.

A. Governmental Equipment Lease-Purchase Agreement. The Governmental Lease-Purchase Agreement contains the terms that govern each transaction between us. It is the standard Caterpillar Financial Services Corporation tax exempt lease-purchase agreement, and provides that we will lease to you the equipment described therein pursuant to a full payout amortization schedule. A new Governmental Equipment Lease-Purchase Agreement will have to be signed in connection with each transaction.

B. Lessee's Authorizing Resolution. The Authorizing Resolution is evidence you have taken the necessary governing body actions to approve the Governmental Equipment Lease-Purchase Agreement. Although the authorizing instrument is often a resolution, it may also take other forms such as an ordinance. We are agreeable to using your customary or standard form provided it contains specific approval for the lease-purchase agreement, designates persons who are authorized to sign on your behalf and either approves the document forms or delegates this authority to a named official

C. Verification of Insurance. The Certificate of Insurance is intended to supply information regarding the insurance coverage for the equipment being lease-purchased. You will need to supply the requested information to us so we can verify coverage.

D. Opinion of Counsel. An opinion of counsel is required in connection with each Governmental Equipment Lease-Purchase Agreement. The opinion is intended to confirm that you have complied with all open meeting laws, publication and notice requirements, procedural rules for governing body meetings, and any other relevant state or local government statutes, ordinances, rules or regulations. We would be unable to confirm compliance with these laws and regulations ourselves absent long delays and higher costs so we rely upon the opinion of your attorney since he/she may have been involved in the process to approve our transaction and is an expert in the laws and regulations to which you are subject. The opinion also confirms that you are an entity eligible to issue tax-exempt obligations and that the Governmental Equipment Lease-Purchase Agreement will be treated as tax-exempt as it is your obligation to ensure that you have complied with relevant tax law.

E. Form of 8038G or GC. Form 8038 is required by the Internal Revenue Service in order to monitor the amount of tax-exempt obligations issued. You have to execute a Form 8038 for each Governmental Equipment Lease-Purchase Agreement. Whether a Form 8038 G or GC is required depends on the original principal amount of the Governmental Equipment Lease-Purchase Agreement. If the original principal amount is less than \$100,000 Form 8038GC is filed with the IRS. If the original principal amount is \$100,000 or more Form 8038G is filed with the IRS. Choose the appropriate 8038 form and complete according to IRS guidelines. Contact your TM or Sales Support Representative for assistance.

IRS Form 8038G

<http://www.irs.gov/pub/irs-pdf/f8038g.pdf>

IRS Form 8038GC

<http://www.irs.gov/pub/irs-pdf/f8038gc.pdf>

This Explanation of Contents is prepared as an accommodation to the parties named herein. It is intended as an example of some of the documents that Caterpillar Financial Services Corporation, in its reasonable judgment, may require and is not intended to constitute legal advice. Please engage and use your own legal counsel. We understand that the laws of the various states are different so nothing herein shall be construed as a warranty or representation that the documents listed herein are the only documents that may be required in any particular transaction or that any particular transaction, if documented in accordance with this Explanation of Contents, will be a valid, binding and enforceable obligation enforceable against the parties named herein in accordance with the terms of the documents named herein.

These documents were prepared especially for:

COUNTY OF HIDALGO
2818 S BUSINESS HIGHWAY 281
EDINBURG, TX 78539

Dealer: HOLT TEXAS, LTD, E140
Date: 12/15/2015 Time: 12:51 PM
Comments:

Customer Executed Documents **Comments**

- Lease Purchase Document _____
- Delivery Certification _____
- Insurance Verification _____
- 8038G or 8038GC _____
- Advance Payment (cross out if N/A) _____
- Customer Information Verification _____
- Tax Exemption Certificate _____
- Any necessary Riders/Amendments _____
- Lessee's Resolution + Minutes of Meeting **OR** _____
- Opinion of Lessee's Counsel _____
- Copy of Driver's License (Sole Proprietorships and
Individuals) _____

Dealer Executed Documents **Comments**

- Purchase Agreement _____
- Dealer Invoice _____
- All Credit Conditions Met _____

**If any of these documents are altered, or if the Buyer wishes to add or delete documents, please contact your CFSC Credit Analyst to obtain acceptance of any and all changes.*



Governmental Equipment Lease-Purchase Agreement
Transaction Number 2758156



1. PARTIES

LESSOR ("we", "us", or "our"):
 CATERPILLAR FINANCIAL SERVICES CORPORATION
 2120 West End Avenue
 Nashville, TN 37203

LESSEE ("you" or "your"):
 COUNTY OF HIDALGO
 2818 S BUSINESS HIGHWAY 281
 EDINBURG, TX 78539

In reliance on your selection of the equipment described below (each a "Unit"), we have agreed to acquire and lease the Units to you, subject to the terms of this Lease. Until this Lease has been signed by our duly authorized representative, it will constitute an offer by you to enter into this Lease with us on the terms stated herein.

2. DESCRIPTION OF THE UNITS

DESCRIPTION OF UNITS Whether the Unit is new or used, the model number, the manufacturer, and the model name.	SERIAL/VIN Unique ID number for this Unit.	ANNUAL LEASE PAYMENT This is due per period, as stated below in section 3.	FINAL LEASE PAYMENT	DELIVERY DATE Enter date machine was delivered to you
(1) New CT660 Caterpillar On-Highway Truck		\$24,709.27	\$1.00	_____
(1) New CT660 Caterpillar On-Highway Truck		\$24,709.27	\$1.00	_____

TERMS AND CONDITIONS

3. **Lease Payments; Current Expense** You will pay us the lease payments, including the final lease payment set forth above (collectively, the "Lease Payments"). Lease Payments will be paid by you to us as follows: a first payment of \$49,418.54 will be paid in advance and the balance of the Lease Payments is payable in 7 successive annual payments of which the first 6 payments are in the amount of \$49,418.54 each, and the last payment is in the amount of \$2.00 plus all other amounts then owing under this Lease, with the first Lease Payment due on the date that we sign this Lease and subsequent Lease Payments due on a like date of each year thereafter until paid in full. A portion of each Lease Payment constitutes interest and the balance of each Lease Payment is payment of principal. The Lease Payments will be due without demand. You will pay the Lease Payments to us at Caterpillar Financial Services Corporation; PO Box 730681; Dallas, TX 75373-0681 or such other location that we designate in writing. Your obligations, including your obligation to pay the Lease Payments due in any fiscal year, will constitute a current expense of yours for such fiscal year and will not constitute an indebtedness of yours within the meaning of the constitution and laws of the State in which you are located (the "State"). Nothing in this Agreement will constitute a pledge by you of any taxes or other moneys, other than moneys lawfully appropriated from time to time for the payment of the "Payments" (as defined in the last sentence of this Section) owing under this Agreement. You agree that, except as provided in Section 7, your duties and liabilities under this Agreement and any associated documents are absolute and unconditional. Your payment and performance obligations are not subject to cancellation, reduction, or setoff for any reason. You agree to settle all claims, defenses, setoffs, counterclaims and other disputes you may have with the Supplier, the manufacturer of the Unit, or any other third party directly with the Supplier, the manufacturer or the third party, as the case may be. You will not assert, allege or make any such claim, defense, setoff, counterclaim or other dispute against us or with respect to the payments due us under this Agreement. As used in this Agreement, "Payments" will mean the Lease Payments and any other amounts required to be paid by you.

The portion of the Lease Payments constituting principal will bear interest (computed on the basis of actual days elapsed in a 360 day year) at the rate of 3.20% per annum.

4. **Late Charges** If we do not receive a Payment on the date it is due, you will

pay to us, on demand, a late payment charge equal to the lesser of five percent (5%) of such Payment or the highest charge allowed by law.

5. **Security Interest** To secure your obligations under this Agreement, you grant us a continuing first priority security interest in each Unit (including any Additional Collateral), including all attachments, accessories and optional features (whether or not installed on such Units) and all substitutions, replacements, additions, and accessions, and the proceeds of all the foregoing, including, but not limited to, proceeds in the form of chattel paper. You authorize the filing of such financing statements and will, at your expense, do any act and execute, acknowledge, deliver, file, register and record any document, which we deem desirable to protect our security interest in each Unit and our rights and benefits under this Agreement. You, at your expense, will protect and defend our security interest in the Units and will keep the Units free and clear of any and all claims, liens, encumbrances and legal processes however and whenever arising.

6. **Disclaimer of Warranties** WE HAVE NOT MADE AND DO NOT MAKE ANY WARRANTY, REPRESENTATION OR COVENANT OF ANY KIND, EXPRESS OR IMPLIED, AS TO THE UNITS. AS TO US, YOUR LEASE AND PURCHASE OF THE UNITS WILL BE ON AN "AS IS" AND "WHERE IS" BASIS AND "WITH ALL FAULTS". Nothing in this Agreement is intended to limit, waive, abridge or otherwise modify any rights, claims, or causes of action that you may have against any person or entity other than us.

7. **Non-Appropriation** You have an immediate need for, and expect to make immediate use of, the Units. This need is not temporary or expected to diminish during the term of this Agreement. To that end, you agree, to the extent permitted by law, to include in your budget for the current and each successive fiscal year during the term of this Agreement, a sufficient amount to permit you to discharge your obligations under this Agreement. Notwithstanding any provision of this Agreement to the contrary, we and you agree that, in the event that prior to the commencement of any of your fiscal years you do not have sufficient funds appropriated to make the Payments due under this Agreement for such fiscal year, you will have the option of terminating this Agreement as of the date of the commencement of such fiscal year by giving us sixty (60) days prior written notice of your intent to terminate. No later than the last day of the last fiscal year for which appropriations were made for the Payments (the "Return Date"), you will



return to us all of the Units, at your sole expense, in accordance with Section 14, and this Agreement will terminate on the Return Date without penalty or expense to you and you will not be obligated to pay the Lease Payments beyond such fiscal year; provided, that you will pay all Payments for which moneys have been appropriated or are otherwise available; and provided further, that you will pay month to-month rent at the rate set by us for each month or part of any month that you fail to return the Units.

8. Tax Warranty You will, at all times, do and perform all acts and things necessary and within your control to ensure that the interest component of the Lease Payments will, for the purposes of Federal income taxation, be excluded from our gross income. You will not permit or cause your obligations under this Agreement to be guaranteed by the Federal Government or any branch or instrumentality of the Federal Government. You will use the Units for the purpose of performing one or more of your governmental functions consistent with the scope of your authority and not in any trade or business carried on by a person other than you. You will report this Agreement to the Internal Revenue Service by filing Form 8038G, 8038GC or 8038, as applicable. Failure to do so will cause this Agreement to lose its tax exempt status. You agree that if the appropriate form is not filed, the interest rate payable under this Agreement will be raised to the equivalent taxable interest rate. If the use, possession or acquisition of the Units is determined to be subject to taxation, you will pay when due all taxes and governmental charges assessed or levied against or with respect to the Units.

9. Assignment You may not, without our prior written consent, by operation of law or otherwise, assign, transfer, pledge, hypothecate or otherwise dispose of your right, title and interest in and to this Agreement and/or the Units and/or grant or assign a security interest in this Agreement and/or the Units, in whole or in part. We may not transfer, sell, assign, pledge, hypothecate, or otherwise dispose of our right, title and interest in and to this Agreement and/or the Units and/or grant or assign a security interest in this Agreement and/or the Units, in whole or in part.

10. Indemnity To the extent permitted by law, you assume liability for, agree to and do indemnify, protect and hold harmless us and our employees, officers, directors and agents from and against any and all liabilities, obligations, losses, damages, injuries, claims, demands, penalties, actions, costs and expenses (including reasonable attorney's fees), of whatsoever kind and nature, arising out of the use, condition (including, but not limited to, latent and other defects and whether or not discoverable by you or us), operation, ownership, selection, delivery, storage, leasing or return of any item of Units, regardless of where, how and by whom operated, or any failure on your part to accept the Units or otherwise to perform or comply with any conditions of this Agreement.

11. Insurance; Loss and Damage You bear the entire risk of loss, theft, destruction or damage to the Units from any cause whatsoever. No loss, theft, destruction or damage of the Units will relieve you of the obligation to make Lease Payments or to perform any obligation owing under this Agreement. You agree to keep the Units insured to protect all of our interests, at your expense, for such risks, in such amounts, in such forms and with such companies as we may require, including but not limited to fire and extended coverage insurance, explosion and collision coverage, and personal liability, property damage liability, and environmental liability insurance. Any insurance policies relating to loss or damage to the Units will name us as loss payee as our interests may appear and the proceeds may be applied toward the replacement or repair of the Units or the satisfaction of the Payments due under this Agreement. You agree to use, operate and maintain the Units in accordance with all laws, regulations and ordinances and in accordance with the provision of any policies of insurance covering the Units, and will not rent the Units or permit the Units to be used by anyone other than you. You agree to keep the Units in good repair, working order and condition and house the Units in suitable shelter, and to permit us or our assigns to inspect the Units at any time and to otherwise protect our interests in the Units. If any Unit is customarily covered by a maintenance agreement, you will furnish us with a maintenance agreement by a party acceptable to us.

If any hazardous property or material will be transported with a Unit, you will provide and maintain environmental liability coverage at all times during the term of this Agreement, at your expense and in your own name as primary insured, for the greater of \$5,000,000 or the statutory minimum coverage.

This environmental liability coverage will have a deductible amount reasonably acceptable to us and will provide a waiver of subrogation by the

insurance carrier in favor of us. The insurance carrier must have a minimum rating of A- by A.M. Best or a credit rating of "BBB" by Standard & Poor's or Fitch with an A.M. Best Financial Size Category of 7 or higher.

12. Default; Remedies An "Event of Default" will occur if (a) you fail to pay any Payment when due and such failure continues for ten (10) days after the due date for such Payment or (b) you fail to perform or observe any other covenant, condition, or agreement to be performed or observed by you under this Agreement and such failure is not cured within twenty (20) days after written notice of such failure from us. Upon an Event of Default, we will have all rights and remedies available under applicable law. In addition, we may declare all Lease Payments due or to become due during the fiscal year in which the Event of Default occurs to be immediately due and payable by you and/or we may repossess the Units by giving you written notice to deliver the Units to us in the manner provided in Section 14, or in the event you fail to do so within ten (10) days after receipt of such notice, and subject to all applicable laws, we may enter upon your premises and take possession of the Units. Further, if we financed your obligations under any extended warranty agreement such as an Equipment Protection Plan, Extended Service Contract, Extended Warranty, Customer Service Agreement, Total Maintenance and Repair Agreement or similar agreement, we may cancel such extended warranty agreement on your behalf and receive the refund of the extended warranty agreement fees that we financed but had not received from you as of the date of the Event of Default.

13. Miscellaneous This Agreement may not be modified, amended, altered or changed except by a written agreement signed by you and us. In the event any provision of this Agreement is found invalid or unenforceable, the remaining provisions will remain in full force and effect. This Agreement, together with exhibits, constitutes the entire agreement between you and us and supersedes all prior and contemporaneous writings, understandings, agreements, solicitations, documents and representations, expressed or implied. Any terms and conditions of any purchase order or other documents submitted by you in connection with this Agreement which are in addition to or inconsistent with the terms and conditions of this Agreement will not be binding on us and will not apply to this Agreement. You agree that we may correct patent errors in this Agreement and fill in blanks including, for example, correcting or filling in serial numbers, VIN numbers, and dates. Any notices required to be given under this Agreement will be given to the parties in writing and by certified mail at the address provided in this Agreement, or to such other addresses as each party may substitute by notice to the other, which notice will be effective upon its receipt.

14. Title; Return of Units Notwithstanding our designation as "Lessor", we do not own the Units. Legal title to the Units will be in you so long as an Event of Default has not occurred and you have not exercised your right of non-appropriation. If an Event of Default occurs or if you non-appropriate, full and unencumbered title to the Units will pass to us without the necessity of further action by the parties, and you will have no further interest in the Units. If we are entitled to obtain possession of any Units or if you are obligated at any time to return any Units, then (a) title to the Units will vest in us immediately, and (b) you will, at your expense, promptly deliver the Unit to us properly protected and in the condition required by Section 11. You will deliver the Unit, at our option, (i) to the nearest Caterpillar dealer selling equipment of the same type as the Unit; or (ii) on board a carrier named by us and shipping the Unit, freight collect, to a destination designated by us. If the Unit is not in the condition required by Section 11, you must pay us, on demand, all costs and expenses incurred by us to bring the Unit into the required condition. Until the Units are returned as required above, all terms of this Agreement will remain in full force and effect including, without limitation, your obligation to pay Lease Payments and to insure the Units.

15. Other Documents In connection with the execution of this Agreement, you will cause to be delivered to us (i) either (A) a certified copy of your authorizing resolution substantially in the form attached as Attachment B and a copy of the minutes of the relevant meeting or (B) an opinion of your counsel substantially in the form attached as Attachment C; (ii) a Verification of Insurance substantially in the form attached to this Agreement; (iii) a copy of the signed Form filed with the Internal Revenue Service required in Section 8 above as Attachment D; and (iv) any other documents or items required by us.

16. Applicable Law This Agreement will be governed by the laws, excluding the laws relating to the choice of law, of the State in which you are located.

SIGNATURES

LESSOR
CATERPILLAR FINANCIAL SERVICES CORPORATION

Signature _____

Name (print) _____

Title _____

Date _____

LESSEE
COUNTY OF HIDALGO

Signature _____

Name (print) _____

Title _____

Date _____

CUSTOMER INFORMATION VERIFICATION
(Required Document)



In our efforts to continue providing timely customer service, we need your assistance confirming the following information. If any information is incorrect or missing, please note the necessary changes below and return this form with your signed documents. In addition, please review the Data Privacy Notice stated below. Thank you in advance for your cooperation.

Purchase Order # for new contract: _____

Current Information on file **Please make corrections here**

Customer Name: COUNTY OF HIDALGO _____
Physical Address: 2818 S BUSINESS HIGHWAY 281 _____
EDINBURG, TX 78539 _____
Mailing Address: 2818 S BUSINESS HIGHWAY 281 _____
EDINBURG, TX 78539 _____
Equipment Location: 1/2MILE W FM 1427 MILITARY HWY _____
PENITAS, TX 78576, HIDALGO _____
Business Phone: (956)292-7025 _____
E-mail Address: SERGIO.CRUZ@CO.HIDALGO.TX.US _____
Accounts Payable Contact Name and Phone: _____

Tax Information
Sales Tax Rate: 0 _____

(Please note: Sales Tax Rate, includes all applicable State, County, and City sales tax)

City Limits Asset outside the City Limits? Yes ___ No ___

Tax Exemption Status

Please indicate if you are tax exempt. Exempt*
 Non-Exempt

**A Tax Exemption Certificate is required for all tax exempt customers. If you are tax exempt - please enclose a current tax exemption certificate to be returned with your documents.*

The information above has been reviewed and is accurate to the best of my knowledge with exception of any corrections as noted.

*Should the above changes apply to ALL of your contracts, OR for this contract ONLY?

- ALL CONTRACTS
- THIS CONTRACT ONLY

THE ABOVE INFORMATION HAS BEEN REVIEWED AND IS ACCURATE TO THE BEST OF MY KNOWLEDGE WITH EXCEPTION OF ANY CORRECTIONS AS NOTED.

Customer Initials

Data Privacy Notice: *This notice pertains to personal data supplied in connection with your credit application. By providing your information to Caterpillar Inc. or any of its subsidiaries or affiliates, including Caterpillar Financial Services Corporation (collectively "Caterpillar"), you are agreeing that the information may be shared among Caterpillar and its partners and dealers, and used to process your applications for credit and other orders and to improve or market Caterpillar products and services. If you have any questions pertaining to this notice, please contact the Data Privacy Coordinator at 615-341-8222.*



GOVERNMENTAL ENTITY RESOLUTION TO LEASE, PURCHASE AND/OR FINANCE

WHEREAS, the laws of the State of Texas (the "State") authorize COUNTY OF HIDALGO (the "Governmental Entity"), a duly organized political subdivision, municipal corporation or similar public entity of the State, to purchase, acquire and lease personal property for the benefit of the Governmental Entity and its inhabitants and to enter into any necessary contracts; and

the Governmental Entity wants to lease, purchase and/or finance equipment ("Equipment") from Caterpillar Financial Services Corporation and/or an authorized Caterpillar dealer ("Caterpillar") by entering into that certain Governmental Equipment Lease-Purchase Agreement (the "Agreement") with Caterpillar; and

the form of the Agreement has been presented to the governing body of the Governmental Entity at this meeting.

RESOLVED, that: (i) the Agreement, including all schedules and exhibits attached to the Agreement, is approved in substantially the form presented at the meeting, with any Approved Changes (as defined below), (ii) the Governmental Entity enter into the Agreement with Caterpillar and (iii) the Agreement is adopted as a binding obligation of the Governmental Entity; and

that changes may later be made to the Agreement if the changes are approved by the Governmental Entity's counsel or members of the governing body of the Governmental Entity signing the Agreement (the "Approved Changes") and that the signing of the Agreement and any related documents is conclusive evidence of the approval of the changes; and

that the persons listed below, who are the incumbent officers of the Governmental Entity (the "Authorized Persons"):

Name (Print or Type)	Title (Print or Type)
_____	_____
_____	_____
_____	_____

be, and each is, authorized, directed and empowered, on behalf of the Governmental Entity, to (i) sign and deliver to Caterpillar, and its successors and assigns, the Agreement and any related documents, and (ii) take or cause to be taken all actions he/she deems necessary or advisable to acquire the Equipment, including the signing and delivery of the Agreement and related documents; and

that the Secretary/Clerk of the Governmental Entity is authorized to attest to these resolutions and affix the seal of the Governmental Entity to the Agreement, these resolutions, and any related documents; and

that nothing in these resolutions, the Agreement or any other document imposes a pecuniary liability or charge upon the general credit of the Governmental Entity or against its taxing power, except to the extent that the payments payable under the Agreement are special limited obligations of the Governmental Entity as provided in the Agreement; and

that a breach of these resolutions, the Agreement or any related document will not impose any pecuniary liability upon the Governmental Entity or any charge upon its general credit or against its taxing power, except to the extent that the payments payable under the Agreement are special limited obligations of the Governmental Entity as provided in the Agreement; and

that the authority granted by these resolutions will apply equally and with the same effect to the successors in office of the Authorized Persons.

I, _____, _____ of COUNTY OF HIDALGO, certify that the resolutions above are a full, true and correct copy of resolutions of the governing body of the Governmental Entity. I also certify that the resolutions were duly and regularly passed and adopted at a meeting of the governing body of the Governmental Entity. I also certify that such meeting was duly and regularly called and held in all respects as required by law, at the Governmental Entity's office. I also certify that at such meeting, a majority of the governing body of the Governmental Entity was present and voted in favor of these resolutions.

I also certify that these resolutions are still in full force and effect and have not been amended or revoked.

IN WITNESS of these resolutions, the officer named below executes this document on behalf of the Governmental Entity.

Signature: _____
Title: _____
Date: _____





Verification of Insurance

Lessee:

LESSOR (we):

CATERPILLAR FINANCIAL SERVICES CORPORATION
2120 West End Avenue
Nashville, TN 37203-0001

LESSEE (you):

COUNTY OF HIDALGO
2818 S BUSINESS HIGHWAY 281
EDINBURG, TX 78539

Subject: Insurance Coverage Requirements

1. The above-named Lessor and Lessee have entered into Governmental Equipment Lease-Purchase Agreement Transaction Number 2758156 (the "Agreement"). In accordance with the Agreement, Lessee has instructed the insurance agent named below:

Company: _____

Address: _____

Phone No: _____

Agent's Name: _____

to issue:

a. All Risk Physical Damage Insurance on the Equipment (as defined in the Agreement) evidenced by a Certificate of Insurance and Long Form Loss Payable Clause naming the Lessor and/or its Assignee, as loss payee.

The Coverage Required: the aggregate purchase price for the Equipment.

b. Public Liability Insurance evidenced by a Certificate of Insurance, naming the Lessor and/or its Assignee as Additional Insured, with a minimum of \$1,000,000 per occurrence is required.

2. Proof of insurance coverage will be provided to Lessor or its Assignee prior to the time the Equipment is delivered to Lessee..

Model #	Equipment Description	Serial #	VIN #	Value Including Tax
1. CT660	Caterpillar On-Highway Truck			\$157,507.11
2. CT660	Caterpillar On-Highway Truck			\$157,507.11

SIGNATURES

LESSEE

COUNTY OF HIDALGO

Signature _____

Name (print) _____

Title _____

Date _____



Opinion of Counsel

**Re: Governmental Equipment Lease-Purchase Agreement (Transaction Number 2758156) (the "Lease")
Between COUNTY OF HIDALGO("Lessee") and Caterpillar Financial Services Corporation ("Lessor")**

Sir/Madam:

I am an attorney for Lessee, and in that capacity I am familiar with the above-referenced transaction, the Lease, and all other documents pertaining to the Lease (the Lease and such other documents pertaining to the Lease being referred to as the "Lease Agreements").

Based on my examination of these and such other documents, records and papers and matters of fact and laws as I deemed to be relevant and necessary as the basis for my opinion set forth below, upon which opinion Lessee and any subsequent assignee of Lessee's interest may rely, it is my opinion that:

1. Lessee is a fully constituted political subdivision or agency duly organized and existing under the Constitution and laws of the State of Texas (the "State"), and is authorized by such Constitution and laws (i) to enter into the transaction contemplated by the Lease Agreements and (ii) to carry out its obligations thereunder.
2. The Lease Agreements (i) have been duly authorized, executed and delivered by Lessee and (ii) constitute valid, legal and binding obligations and agreements of Lessee, enforceable against Lessee in accordance with their terms, assuming due authorization and execution thereof by Lessor.
3. No further approval, license, consent, authorization or withholding of objections is required from any federal, state or local governmental authority with respect to the entering into or performance by Lessee of the Lease Agreements and the transactions contemplated by the Lease Agreements.
4. Lessee has sufficient appropriations or other funds available to pay all amounts due under the Lease Agreements for the current fiscal year.
5. The interest payable to Lessor by Lessee under the Lease Agreements is exempt from federal income taxation pursuant to Section 103 of the Internal Revenue Code of 1986, as amended.
6. The entering into and performance of the Lease Agreements will not (i) conflict with, or constitute a breach or violation of, any judgment, consent decree, order, law, regulation, bond, indenture or lease applicable to Lessee, or (ii) result in any breach of, or constitute a default under, or result in the creation of, any lien, charge, security interest or other encumbrance upon any assets of Lessee or the Units (as defined in the Lease) pursuant to any indenture, mortgage, deed of trust, bank loan, credit agreement or other instrument to which Lessee is a party, or by which it or its assets may be bound.
7. No litigation or proceeding is pending or, to the best of my knowledge, threatened to, or which may, (a) restrain or enjoin the execution, delivery or performance by Lessee of the Lease Agreements, (b) in any way contest the validity of the Lease Agreements, (c) contest or question (i) the creation or existence of Lessee or its governing body or (ii) the authority or ability of Lessee to execute or deliver the Lease Agreements or to comply with or perform its obligations under the Lease Agreements. There is no litigation or proceeding pending or, to the best of my knowledge, threatened that seeks to or could restrain or enjoin Lessee from annually appropriating sufficient funds to pay the Lease Payments (as defined in the Lease) or other amounts contemplated by the Lease Agreements. In addition, I am not aware of any facts or circumstances which would give rise to any litigation or proceeding described in this paragraph.
8. The Units are personal property and, when subjected to use by Lessee, will not be or become fixtures under the laws of the State.
9. The authorization, approval and execution of the Lease Agreements, and all other proceedings related to the transactions contemplated by the Lease Agreements, have been performed in accordance with all applicable open meeting, public records, public bidding and all other applicable laws, rules and regulations of the State.
10. The appropriation of moneys to pay the Lease Payments coming due under the Lease and any other amounts contemplated by the Lease Agreements does not and will not result in the violation of any constitutional, statutory or other limitation relating to the manner, form or amount of indebtedness which may be incurred by Lessee.
11. The Lessor will have a perfected security interest in the Units upon the filing of an executed UCC-1 or other financing statement at the time of acceptance of the Units with the Secretary of State for the State.

SIGNATURE

Name (PRINT): _____

Date: _____

Signature: _____

Address: _____

Title: _____



**Amendment to Governmental Lease-Purchase Agreement (Texas)
Transaction Number 2758156**



This Amendment (the "Amendment"), dated _____ (the "Effective Date"), to the Governmental Lease-Purchase Agreement (the "Agreement") for the Transaction Number set out above is by and between the parties identified below.

1. PARTIES

LESSOR:

LESSEE:

CATERPILLAR FINANCIAL SERVICES CORPORATION
2120 West End Avenue
Nashville, TN 37203-0001

COUNTY OF HIDALGO
2818 S BUSINESS HIGHWAY 281
EDINBURG, TX 78539

2. TERMS AND CONDITIONS

- a) Capitalized terms used but not defined herein will have the meaning given them in the Agreement.
- b) Except as provided herein, the Agreement will remain unchanged and in full force and effect in accordance with its terms. Any additional modifications are null and void unless approved in writing by you and us. Nothing herein will be deemed to be a waiver or amendment of any other provision contained in the Agreement or any of our rights or remedies under the Agreement.
- c) As of the Effective Date, the Agreement is amended as set forth below.

3. AMENDMENT

Section 7 of the Agreement is amended and restated in its entirety as follows:

"7. **Annual Right of Termination.** You may terminate this Agreement as of the last day of any fiscal year during the term hereof by giving us sixty (60) days prior written notice (although the failure to give such notice will not affect your right to terminate this Agreement as provided herein). In the event you terminate this Agreement during the term hereof pursuant to this Section, you will, no later than the last day of such fiscal year, return to us all, but not less than all, of the Units, at your sole expense and in accordance with the terms of this Agreement. Upon such return, this Agreement will terminate as of the last day of such fiscal year (the "Termination Date"). Thereafter, you will not incur any additional obligations under this Agreement, provided, however, that you must pay all Lease Payments and other Payments due prior to the Termination Date or attributable to such period, and provided, further, that you must pay month-to-month lease payments at the rate set forth in this Agreement for each month or part thereof that you fail to return the Units."

SIGNATURES

CATERPILLAR FINANCIAL SERVICES CORPORATION

COUNTY OF HIDALGO

Signature _____

Signature _____

Name (print) _____

Name (print) _____

Title _____

Title _____

Date _____

Date _____



Caterpillar Financial Services Corporation

INVOICE

Page	Date	Invoice No.
1	12/15/2015	LSAP-414936405-1

COUNTY OF HIDALGO
 2818 S BUSINESS HIGHWAY 281
 EDINBURG, TX 78539

Description	Serial	VIN	Due Date	Pmt. No.	Amount
(1) CT660 Caterpillar On-Highway Truck			Upon Receipt.	1	\$24,709.27
Sales and Use Tax					\$0.00
Document Fee					\$0.00
Filing Fee					\$0.00
Stamp Fee					\$0.00
Other Fees					\$0.00
Freight Fee					\$0.00
WITHOUT THE APPROPRIATE TAX EXEMPTION CERTIFICATE, APPLICABLE SALES AND/OR USE TAX WILL BE CHARGED.					

PLEASE PAY THIS AMOUNT \$ \$24,709.27

Invoice No.	Total Enclosed
LSAP-414936405-1	\$

COUNTY OF HIDALGO
 2818 S BUSINESS HIGHWAY 281
 EDINBURG, TX 78539

Remit To: Caterpillar Financial Services Corporation
 5th Floor Document Services
 Doc Specialist: HOLT TEXAS, LTD
 2120 West End Ave.
 Nashville, TN 37203

RETURN INVOICE AND CHECK FOR SPECIFIED PAYMENT(S) WITH SIGNED DOCUMENTS.
 Your check will be cashed by Caterpillar Financial Services Corporation (CFSC) upon receipt, but that act will not constitute acceptance by CFSC of the Loan, Lease or Schedule. If CFSC accepts and executes the Loan, Lease or Schedule, the proceeds of this check will be applied to the specified payments. If CFSC does not accept the Loan, Lease or Schedule, CFSC will return an amount equal to this check.



Caterpillar Financial Services Corporation

INVOICE

Page	Date	Invoice No.
1	12/15/2015	LSAP-414936405-2

COUNTY OF HIDALGO
2818 S BUSINESS HIGHWAY 281
EDINBURG, TX 78539

Description	Serial	VIN	Due Date	Pmt. No.	Amount
(1) CT660 Caterpillar On-Highway Truck			Upon Receipt.	1	\$24,709.27
Sales and Use Tax					\$0.00

WITHOUT THE APPROPRIATE TAX EXEMPTION CERTIFICATE, APPLICABLE SALES AND/OR USE TAX WILL BE CHARGED.

PLEASE PAY THIS AMOUNT \$ \$24,709.27

Invoice No.	Total Enclosed
LSAP-414936405-2	\$

COUNTY OF HIDALGO
2818 S BUSINESS HIGHWAY 281
EDINBURG, TX 78539

Remit To: Caterpillar Financial Services Corporation
5th Floor Document Services
Doc Specialist: HOLT TEXAS, LTD
2120 West End Ave.
Nashville, TN 37203

RETURN INVOICE AND CHECK FOR SPECIFIED PAYMENT(S) WITH SIGNED DOCUMENTS.

Your check will be cashed by Caterpillar Financial Services Corporation (CFSC) upon receipt, but that act will not constitute acceptance by CFSC of the Loan, Lease or Schedule. If CFSC accepts and executes the Loan, Lease or Schedule, the proceeds of this check will be applied to the specified payments. If CFSC does not accept the Loan, Lease or Schedule, CFSC will return an amount equal to this check.

Meeting Minutes

HOLT TEXAS, LTD
HOLT AVE @ SOUTH W W WHITE RD
P.O. BOX 207916
SAN ANTONIO TX 782207916

Reference:

COUNTY OF HIDALGO

We are requesting a copy of the minutes of the appropriation meeting during which the funds for this deal were allocated.

A copy of this information is necessary to complete the documentation package and to fund the deal. Your ability to return a complete package will ensure timely payment to you.

Thank you for your assistance.

CATERPILLAR FINANCIAL SERVICES CORPORATION
DOCUMENTATION DEPARTMENT





This Purchase Agreement is between **HOLT TEXAS, LTD** ("Vendor") and **Caterpillar Financial Services Corporation** ("Cat Financial"). Vendor agrees to sell to Cat Financial and Cat Financial agrees to buy from Vendor the equipment described below (the "Unit(s)"), subject to the terms and conditions set forth below and on the reverse side hereof.

<u>Description of Unit(s)</u>	<u>Serial#</u>	<u>VIN #</u>	<u>Freight</u>	<u>Total Price</u>
(1) CT660 New Caterpillar On-Highway Truck			\$0.00	\$157,507.11
(1) CT660 New Caterpillar On-Highway Truck			\$0.00	\$157,507.11

Lessee:
COUNTY OF HIDALGO
2818 S BUSINESS HIGHWAY 281
EDINBURG TX 78539

Subtotal	\$315,014.22
Federal Excise Tax	0.00
Other Tax	0.00
Total Purchase Price	\$315,014.22
Unit(s) Delivery Point:	
1/2MILE W FM 1427 MILITARY HWY, PENITAS, TX 78576, HIDALGO	

See next page for additional terms and conditions.

SIGNATURES

CATERPILLAR FINANCIAL SERVICES CORPORATION

HOLT TEXAS, LTD

Signature _____
Name (print) _____
Title _____
Date _____

Signature _____
Name (print) _____
Title _____
Date _____

1. The lessee named on the front hereof (the "Lessee") has selected the Unit(s), instructed Cat Financial to purchase the Unit(s) from Vendor, and agreed to lease the Unit(s) from Cat Financial.
2. Cat Financial (or its assignee) will have no obligation hereunder (and any sums previously paid by Cat Financial to Vendor with respect to the Unit(s) shall be promptly refunded to Cat Financial) unless (a) all of the conditions set forth in Section 1.3 (if a master lease agreement) or Section 1 (if a non master lease agreement) of the lease with the Lessee covering the Unit(s) have been timely fulfilled and (b) the Lessee has not communicated to Cat Financial (or its assignee), prior to "Delivery" (as hereinafter defined) of the Unit(s), an intent not to lease the Unit(s) from Cat Financial. All conditions specified in this paragraph shall be deemed timely fulfilled unless prior to Delivery of the Unit(s), Cat Financial (or its assignee) shall notify Vendor to the contrary in writing, which shall include fax or email. "Delivery" shall mean the later of the time (a) Cat Financial executes this Purchase Agreement or (b) the Lessee or its agent takes control and/or physical possession of the Unit(s).
3. Upon timely satisfaction of the conditions specified in Paragraph 2 above, ownership, title and risk of loss to the Unit(s) shall transfer to Cat Financial (or its assignee) upon Delivery of the Unit(s).
4. Vendor warrants that (a) upon Delivery of the Unit(s), Cat Financial (or its assignee) will be the owner of and have absolute title to the Unit(s) free and clear of all claims, liens, security interests and encumbrances and the description of the Unit(s) set forth herein is correct and (b) the Unit Transaction Price set forth on the front hereof for each unit of Unit(s) leased under a lease is equal to such Unit(s)'s fair market value.
5. Vendor shall forever warrant and defend the sale of the Unit(s) to Cat Financial (or its assignee), its successors and assigns, against any person claiming an interest in the Unit(s).
6. Provided that no event of default exists under any agreement between Lessee and Cat Financial and upon timely satisfaction of the conditions specified in Paragraph 2 above, and unless otherwise agreed to in this Purchase Agreement, Cat Financial (or its assignee) shall pay Vendor the total Purchase Price set forth on the front hereof for the Unit(s) within three business days following (a) the receipt and approval by Cat Financial of all documentation deemed necessary by Cat Financial in connection with the lease transaction and (b) all credit conditions have been satisfied.
7. Vendor shall deliver the Unit(s) to the Lessee at the delivery point set forth on the front hereof.
8. This Purchase Agreement may be assigned by Cat Financial to a third party. Vendor hereby consents to any such assignment.
9. This Purchase Agreement shall become effective only upon execution by Cat Financial.

Caterpillar Financial Services Corporation

Finance Proposal

2016-023

TWO (2) CT660S-TRUCK (PCT 3)

CUSTOMER

Name: COUNTY OF HIDALGO

Address 2818 S BUSINESS HIGHWAY 281
 City EDINBURG
 State TX
 Zip code 78539
 County HIDALGO

Good if:
 Acknowledged by Mar-02-16
 Funded by Mar-02-16

DEALER

HOLT TEXAS, LTD
 Sales person MARK BRUNNEMANN
 Dealer contact
 Telephone

Quote number 493-6405
 Fax number
 Quote date 12/08/2015
 Quote time 13:31:53

FINANCE PROPOSAL

This is Caterpillar Financial Services Corporation's confirmation of the following finance proposal. This is a proposal only and is subject to credit approval, execution of documentation, and execution and approval of the application survey.

Financing type GOVERNMENTAL
 Number of payments 7 Annual
 Payments in Advance
 Quoted by e095mm
 Report created by e140tlc

	Model	Ann. Miles	Qty	Sale Price	Amount Financed	Payment	Balloon	Fixed Rate
New	CT660	50000	1	157,507.11	157,682.11	24,709.27	1.00	3.2000
New	CT660	50000	1	157,507.11	157,682.11	24,709.27	1.00	3.2000
			2	315,014.22	315,364.22	49,418.54	2.00	3.2000

Special Conditions:

CT660

Model Year - 2017, Standard Environment; Major Attachments-Steel Wheels, Manual Transmission, Tandem Axle, 44-46K Rear Axle, 18-20K Front Axle, Walking Beam Suspension, C13 Engine, Air Conditioner, Day Cab; Body - Trailer Type-Roll off/Hooklift

CT660

Model Year - 2017, Standard Environment; Major Attachments-Steel Wheels, Manual Transmission, Tandem Axle, 44-46K Rear Axle, 18-20K Front Axle, Walking Beam Suspension, C13 Engine, Air Conditioner, Day Cab; Body - Trailer Type-Roll off/Hooklift

CONDITIONS

Insurance: The customer must provide evidence of physical damage and liability insurance in an amount and from an insurance carrier satisfactory to CFSC. CFSC must be named on the policies, as loss payee and additional insured, as applicable, and a certificate of insurance, in form and substance acceptable to CFSC, must be provided to CFSC.

Taxes: All taxes are the responsibility of the customer and may or may not be included in the above payment amount.

Equipment: The equipment cannot be delivered until all documents are executed by CFSC. All equipment must reside in the United States at all times.

Approval: This proposal is subject to, among other things, final pricing, credit approval and document approval by CFSC.

The terms and conditions outlined herein are not all-inclusive and are based upon information provided to date. This proposal may be withdrawn or modified by Lessor at anytime. This proposal does not represent an offer or commitment by CFSC to enter into a transaction or to provide financing, and does not create any obligation for CFSC. A commitment to enter into the transaction described herein may only be extended by CFSC after this transaction has been approved by all appropriate credit and other authorities within CFSC.

Please indicate your acceptance of this proposal by executing this proposal and returning it to my attention along with the Proposal Fee at the address below. Please be sure to indicate which financing option you have accepted.

Caterpillar Financial Services Corporation
 2120 West End Avenue, Nashville, TN 37203
 (615)-341-1000

We appreciate the opportunity to provide you a proposal for this transaction.

2016-023

TWO (2) CT660S-TRUCK (PCT 3)

Caterpillar Financial Services Corporation

Finance Proposal

Proposed by:

Acknowledged by:

Caterpillar Financial Services Corporation

COUNTY OF HIDALGO

Date

EXHIBIT 2
Concluding Payment Schedule to
Governmental Agreement

2016-023
TWO (2) CT660S-TRUCK (PCT)

Quote number 493-6405
 Asset #1: "On-Highway Truck" 157,507.11

Dated _____, 20____

between
Caterpillar Financial Services Corporation
 and
COUNTY OF HIDALGO

Description of Unit: 1 Caterpillar CT660

Number of Payments Made	Beginning Balance	Payment Amount	Balloon	Interest 3.20001%	Concluding Payment (*)
1	157,682.11	24,709.27	0.00	0.00	132,972.84
2	132,972.84	24,709.27	0.00	4,255.14	112,518.71
3	112,518.71	24,709.27	0.00	3,600.60	91,410.04
4	91,410.04	24,709.27	0.00	2,925.13	69,625.90
5	69,625.90	24,709.27	0.00	2,228.03	47,144.66
6	47,144.66	24,709.27	0.00	1,508.64	23,944.03
7	23,944.03	24,709.27	0.00	766.21	0.97
8	0.97	0.00	1.00	0.03	0.00
		<u>172,964.89</u>	<u>1.00</u>	<u>15,283.78</u>	

(*) Does not include any rent payment or other amount then due.

Initialed: _____
 (Lessee)

EXHIBIT 2
Concluding Payment Schedule to
Governmental Agreement

2016-023
TWO (2) CT660S-TRUCK (PCT)

Quote number 493-6405
 Asset #2: "On-Highway Truck" 157,507.11

Dated _____, 20__

between
Caterpillar Financial Services Corporation
 and
COUNTY OF HIDALGO

Description of Unit: 1 Caterpillar CT660

Number of Payments Made	Beginning Balance	Payment Amount	Balloon	Interest 3.20001%	Concluding Payment (*)
1	157,682.11	24,709.27	0.00	0.00	132,972.84
2	132,972.84	24,709.27	0.00	4,255.14	112,518.71
3	112,518.71	24,709.27	0.00	3,600.60	91,410.04
4	91,410.04	24,709.27	0.00	2,925.13	69,625.90
5	69,625.90	24,709.27	0.00	2,228.03	47,144.66
6	47,144.66	24,709.27	0.00	1,508.64	23,944.03
7	23,944.03	24,709.27	0.00	766.21	0.97
8	0.97	0.00	1.00	0.03	0.00
		<u>172,964.89</u>	<u>1.00</u>	<u>15,283.78</u>	

(*) Does not include any rent payment or other amount then due.

Initialed: _____
 (Lessee)

2016-023 (2) CT660S Truck (Pct3)



Credit Decision Call Back Report

Credit Decision Call Back

Dealer: HOLT TEXAS LTD.
 Dealer Contact:
 Customer: COUNTY OF HIDALGO
 Submitted: 12/04/2015 11:51:57
 App#'s: 2758156
 Amt Requested: \$210,547.22
 Equipment: CT660, CT660

Conditions / Rejection Information:

1) Copy of MSO and Title Application showing CFSC as 1st lien holder; UCC to be filed on the body 2) VIN for truck & S/N for chassis to be provided and FE to be updated prior to funding (if applicable) 3) Trucks should match the build sheet proposal # 1296-01, dated November 22, 2015, presented by Mark Brunneemann of Holt Texas LTD. 4) Completed Truck Addendum to be returned w/ docs 5) 8038G tax form to be returned with docs 6) Resolution and minutes OR opinion of counsel.

Comments:

Credit Decision	Approved as Submitted
Amt Approved:	\$316,364.22
Dn Pmt/Trade:	\$0.00
Term:	84
Finance Type:	Governmental
By:	Mark Daniel
Phone:	(615) 341-1475
Fax:	
At:	12/07/2015 11:39:44

Caterpillar Financial thanks you for your business!

AI-53079

Other 13.

CC - REGULAR

Meeting Date: 01/26/2016

Submitted By: Monica Badillo, EXECUTIVE
OFFICE

Department: EXECUTIVE OFFICE

Information

CAPTION

Discussion and action employing counsel for review of current and past liability lines of coverage for Hidalgo County

BACKGROUND

Fiscal Impact

Attachments

No file(s) attached.

Form Review

Inbox	Reviewed By	Date
Budget & Management	Veronica Ortiz	01/22/2016 03:34 PM
Purchasing Department	Monica Badillo	01/22/2016 04:11 PM
Form Started By: Monica Badillo		Started On: 01/22/2016 02:53 PM
Final Approval Date: 01/22/2016		

AI-53072

Closed Session 14. C.

CC - REGULAR

Meeting Date: 01/26/2016

Submitted By: Monica Badillo, EXECUTIVE
OFFICE

Department: EXECUTIVE OFFICE

Information

CAPTION

Civil Action No. 7:14-cv-471; Eugenio Espinoza Martinez v. Hidalgo County, Texas, et al

BACKGROUND

Fiscal Impact

Attachments

No file(s) attached.

Form Review

Inbox	Reviewed By	Date
Budget & Management	Veronica Ortiz	01/22/2016 02:15 PM
Purchasing Department	Monica Badillo	01/22/2016 04:11 PM
Form Started By: Monica Badillo		Started On: 01/22/2016 01:59 PM
Final Approval Date: 01/22/2016		

AI-53074

Closed Session 14. D.

CC - REGULAR

Meeting Date: 01/26/2016

Submitted By: Monica Badillo, EXECUTIVE
OFFICE

Department: EXECUTIVE OFFICE

Information

CAPTION

C-0262-16-G; Teresa Barrera et al v. Hidalgo County, Texas and Hidalgo County Drainage
District No. 1

BACKGROUND

Fiscal Impact

Attachments

No file(s) attached.

Form Review

Inbox	Reviewed By	Date
Budget & Management	Veronica Ortiz	01/22/2016 02:15 PM
Purchasing Department	Monica Badillo	01/22/2016 04:11 PM
Form Started By: Monica Badillo		Started On: 01/22/2016 02:10 PM
Final Approval Date: 01/22/2016		

AI-53055

Closed Session 14. E.

CC - REGULAR

Meeting Date: 01/26/2016

Submitted Roy Quintanilha, SAFETY DIVISION

For:

Submitted By: Aida Alvarez, SAFETY DIVISION

Department: SAFETY DIVISION

Information

CAPTION

Claim of Verizon

BACKGROUND

Fiscal Impact

Attachments

No file(s) attached.

Form Review

Inbox	Reviewed By	Date
Budget & Management	Veronica Ortiz	01/22/2016 09:40 AM
Purchasing Department	Monica Badillo	01/22/2016 04:11 PM
Form Started By: Aida Alvarez		Started On: 01/21/2016 01:53 PM
Final Approval Date: 01/22/2016		

AI-53060

Closed Session 14. F.

CC - REGULAR

Meeting Date: 01/26/2016

Submitted Roy Quintanilha, SAFETY DIVISION

For:

Submitted By: Aida Alvarez, SAFETY DIVISION

Department: SAFETY DIVISION

Information

CAPTION

Claim of Cesar Rojas & Elena Cortez

BACKGROUND

Fiscal Impact

Attachments

No file(s) attached.

Form Review

Inbox	Reviewed By	Date
Budget & Management	Veronica Ortiz	01/22/2016 09:40 AM
Purchasing Department	Monica Badillo	01/22/2016 04:11 PM
Form Started By: Aida Alvarez		Started On: 01/22/2016 08:20 AM
Final Approval Date: 01/22/2016		

AI-53073

Open Session 16. C.

CC - REGULAR

Meeting Date: 01/26/2016

Submitted By: Monica Badillo, EXECUTIVE
OFFICE

Department: EXECUTIVE OFFICE

Information

CAPTION

Civil Action No. 7:14-cv-471; Eugenio Espinoza Martinez v. Hidalgo County, Texas, et al

BACKGROUND

Fiscal Impact

Attachments

No file(s) attached.

Form Review

Inbox	Reviewed By	Date
Budget & Management	Veronica Ortiz	01/22/2016 02:15 PM
Purchasing Department	Monica Badillo	01/22/2016 04:11 PM
Form Started By: Monica Badillo		Started On: 01/22/2016 02:00 PM
Final Approval Date: 01/22/2016		

AI-53075

Open Session 16. D.

CC - REGULAR

Meeting Date: 01/26/2016

Submitted By: Monica Badillo, EXECUTIVE
OFFICE

Department: EXECUTIVE OFFICE

Information

CAPTION

C-0262-16-G; Teresa Barrera et al v. Hidalgo County, Texas and Hidalgo County Drainage
District No. 1

BACKGROUND

Fiscal Impact

Attachments

No file(s) attached.

Form Review

Inbox	Reviewed By	Date
Budget & Management	Veronica Ortiz	01/22/2016 02:15 PM
Purchasing Department	Monica Badillo	01/22/2016 04:11 PM
Form Started By: Monica Badillo		Started On: 01/22/2016 02:10 PM
Final Approval Date: 01/22/2016		

AI-53056

Open Session 16. E.

CC - REGULAR

Meeting Date: 01/26/2016

Submitted Roy Quintanilha, SAFETY DIVISION

For:

Submitted By: Aida Alvarez, SAFETY DIVISION

Department: SAFETY DIVISION

Information

CAPTION

Claim of Verizon

BACKGROUND

Fiscal Impact

Attachments

No file(s) attached.

Form Review

Inbox	Reviewed By	Date
Budget & Management	Veronica Ortiz	01/22/2016 09:40 AM
Purchasing Department	Monica Badillo	01/22/2016 04:11 PM
Form Started By: Aida Alvarez		Started On: 01/21/2016 01:54 PM
Final Approval Date: 01/22/2016		

AI-53061

Open Session 16. F.

CC - REGULAR

Meeting Date: 01/26/2016

Submitted Roy Quintanilha, SAFETY DIVISION

For:

Submitted By: Aida Alvarez, SAFETY DIVISION

Department: SAFETY DIVISION

Information

CAPTION

Claim of Cesar Rojas & Elena Cortez

BACKGROUND

Fiscal Impact

Attachments

No file(s) attached.

Form Review

Inbox	Reviewed By	Date
Budget & Management	Veronica Ortiz	01/22/2016 09:40 AM
Purchasing Department	Monica Badillo	01/22/2016 04:11 PM
Form Started By: Aida Alvarez		Started On: 01/22/2016 08:24 AM
Final Approval Date: 01/22/2016		