

STATE OF TEXAS §

COUNTY OF HIDALGO §

INTERLOCAL COOPERATION AGREEMENT BETWEEN THE COUNTY OF HIDALGO AND CITY OF MCALLEN, TEXAS CONCERNING RIGHT OF WAY ACQUISITION FROM YUMA AVENUE WEST TO MCCOLL RD

This Agreement is made on this _____ day of _____, 2016 by and between the County of Hidalgo, Texas, hereinafter referred to as “County”, and the City of McAllen, Texas, hereinafter referred to as “City” pursuant to the provisions of the Texas Interlocal Cooperation Act, as follows:

WITNESSETH:

WHEREAS, the City is a home rule municipality located in Hidalgo County, Texas;

WHEREAS, the County is a County in the State of Texas;

WHEREAS, the City and County entered into an Interlocal Agreement dated December 15th, 2015 to make needed road improvements to E. Yuma Avenue from Jackson Rd. to McColl Rd. (the “Prior Project”);

WHEREAS, County in order to complete the Prior Project requires right of way acquisition for certain right of way located within the corporate limits of City (the “Project”) such right of way more particularly described in Exhibit A attached hereto (the “ROW”);

WHEREAS, City consents to the ROW acquisition by County within its corporate limits;

WHEREAS, County upon completion of the Prior Project County shall convey the ROW to City;

WHEREAS, the estimated cost for this ROW acquisition is approximately Eighty Three Thousand Four Hundred Two and no/100ths Dollars (\$83,402.00);

WHEREAS, County and City are authorized to enter into this Agreement pursuant to the Interlocal Cooperation Act, Texas Government Code 791.001 et. Seq. which authorizes local governments to contract with each other to perform governmental functions and services under the terms of the Act; and

NOW, THEREFORE, County and City, in consideration of the mutual covenants expressed hereinafter, agree as follows:

1. County agrees, at County's sole cost and expense, to acquire the ROW and upon completion of the Prior Project to convey the ROW to City.
2. City consents and authorizes County to acquire the ROW within its corporate limits.
3. The Project would benefit the Hidalgo County Regional Linear Park Project by providing connectivity to other portions of the Prior Project.
4. The total estimated cost for the Project will be approximately Eighty Three Thousand Four Hundred Two and no/100ths Dollars (\$83,402.00)
5. County shall provide through its own forces or by third party contractor(s) right of way acquisition for the Project.
6. Pursuant to Tex. Trans. Code 251.012, City authorizes County to perform the work and services described herein with its corporate city limits.
7. The parties further agree that upon completion of the Project, each party shall be responsible for the maintenance and operation of the improvements within each party's respective jurisdiction.
8. Each party agrees to conform to its own applicable purchasing laws, regulations, policies, and procedures with respect to the portion of the work under this Agreement performed by each party.
9. **Conflict of Applicable Law:** Nothing in this Agreement shall be construed so as to require the commission of any act contrary to law, and whenever there is any conflict between any provision of this Agreement and any present or future law, ordinance, or administrative, executive or judicial regulation, order or decree, or amendment thereof, contrary to which the parties have no legal right to contract, the latter shall prevail, but in such event the affected provision or provisions of the Agreement shall be modified only to the extent necessary to bring them within the legal requirements and only during the time such conflict exists.
10. **No Waiver:** No waiver by any party hereto of any breach of any provision of the Agreement shall be deemed to be a waiver of any preceding or succeeding breach of the same or any other provision hereof.
11. **Entire Agreement:** This Agreement contains the entire contract between the parties hereto and each party acknowledges that neither has made (either directly or through any agreement or representative) and representation or agreement in connection with this Agreement not specifically set forth herein. This Agreement may be modified or amended

only by agreement in writing executed by County and City, and not otherwise.

12. **Amendment:** This Agreement cannot be amended, changed, modified, supplemented or revised unless it is evidenced in writing and signed by all parties to this agreement.
13. **TEXAS LAW TO APPLY:** THIS AGREEMENT SHALL BE CONSTRUED UNDER AND IN ACCORDANCE WITH THE LAWS OF THE STATE OF TEXAS, AND ALL OBLIGATIONS OF THE PARTIES CREATED HEREUNDER ARE PERFORMABLE IN HIDALGO COUNTY, TEXAS. THE PARTIES HEREBY CONSENT TO PERSONAL JURISDICTION IN HIDALGO COUNTY, TEXAS.
14. **Notice:** Except as maybe otherwise specifically provided in this Agreement, all notices, demands, requests or communication required or permitted hereunder shall be in writing and shall either be (i) personally delivered against a written receipt, or (ii) sent by registered or certified mail, return receipt requested, postage prepaid and addressed to the parties at the addresses set forth below, or at such other addresses as may have been theretofore specified by written notice delivered in accordance herewith:

If to McAllen: City of McAllen
Attention: Honorable Jim Darling, Mayor
1300 Houston Avenue
McAllen, Texas 78501

If to County: Hidalgo County, Texas
Attn: Honorable Ramon Garcia, Hidalgo County Judge
P. O. Box 758
Edinburg, Texas 78540-0758

Copies to: Honorable Eduardo "Eddie" Cantu, Commissioner, Pct. No. 2
300 W Hall Acres Ste G
Pharr, Texas 78577

Each notice, demand, request or communication which shall be delivered or mailed in the manner described above shall be deemed sufficiently given for all purposes at such time as it is personally delivered to the addressee, or, if mailed, at such time as it is deposited in the United States mail.

15. **Additional Documents:** The parties hereto covenant and agree that they will execute such other and further instruments and documents as are or may become necessary or convenient to effectuate and carry out the terms of this agreement.

16. **Successors:** This Agreement shall be binding upon and inure to the benefit of the parties hereto and their respective successors and assigns where permitted by this Agreement.
17. **Assignment:** This Agreement shall not be assignable.
18. **Headings:** The headings and captions contained in this Agreement are solely for the convenience reference and shall not be deemed to affect the meaning or interpretation of any provision of paragraph hereof.
19. **Gender and Number:** All pronouns used in this Agreement shall include the other gender, whether used in the masculine, feminine or neuter gender, and singular shall include the plural whenever and as often as may be appropriate.
20. **Authority to Execute:** The execution and performance of this Agreement by County and the City have been duly authorized by all necessary laws, resolutions or corporate action, and this Agreement constitutes the valid and enforceable obligations of the County and City in accordance with its terms.
21. **Governmental Purpose:** Each party hereto is entering into the agreement for the purpose of providing for governmental services or functions and will pay for such services out of current revenues available to the paying party as herein provided.
22. **Commitment or Current Revenues Only:** In the event that during any term hereof; the governing body of any party does not appropriate sufficient funds to meet the obligations of such party under this Agreement, then any party may terminate this Agreement upon ninety (90) days written notice to the other party. Each of the parties hereto agrees, however, to use its best efforts to secure funds necessary for the continued performance of this Agreement. The parties intend this provision to be a continuing right to terminate this Agreement at the expiration of each budget period of each party hereto pursuant to the provisions of Tex. Loc. Govt. Code Ann. §271.903.
23. Following completion of construction of the Project each party hereto shall maintain the road and/or linear park described in the Project within their respective jurisdictions where applicable.

WITNESS THE HANDS OF THE PARTIES effective as of the day and year first written above.

CITY OF MCALLEN

By: _____
Jim Darling, Mayor

ATTEST:

City Secretary

COUNTY OF HIDALGO

By: _____
Ramon Garcia, County Judge

ATTEST:

County Clerk

APPROVED AS TO FORM:

By: _____
McAllen City Attorney

APPROVED AS TO FORM:

Atlas, Hall & Rodriguez, L.L.P.

By: _____
Stephen L. Crain

EXHIBIT A

RIGHT OF WAY DESCRIPTION

County: Hidalgo, Precinct 2
WA#22 Supplemental #2: Yuma Extension

Exhibit: A
FIELD NOTES FOR PARCEL 1

Being a 7,120 square foot or 0.16 of an acre tract of land, out of Lot 1, Block 16, Steele and Pershing Subdivision, as recorded in Volume 8, Page 115, of the Deed Records, Hidalgo County, Texas, and being out of a called 0.95 of an acre tract of land, conveyed by Warranty Deed with Vendor's Lien dated October 20, 2005, as described in Document No. 1540418 of the Official Records, Hidalgo County, Texas, said 7,120 square foot or 0.16 of an acre tract of land being more particularly described by metes and bounds as follows;

Commencing at McColl Road, for the Northwest corner of said called 0.95 of an acre tract of land, for the Northwest corner of said Lot 1, Block 16, Steele and Pershing Subdivision;

Thence with the West line of said Lot 1, Block 16, South 08°37'54" West a distance of 50.00 feet to a point;

Thence departing the West line of said Lot 1, Block 16, and across and through said called 0.95 of an acre tract of land, South 81°22'06" East a distance of 50.00 feet to a 5/8" iron pin with plastic cap stamped "R.O.W. PROP. COR." (N=16,590,644.854, E=1,077,146.319) set in the apparent East Right of Way line of McColl Road, for the Southwest corner and **Point of Beginning** of this herein described tract of land;

1. **Thence** departing the South line of said called 0.95 of an acre tract of land, and with the apparent East Right of Way line of McColl Road, North 08°37'54" East a distance of 30.00 feet to the existing South Right of Way line of Yuma Avenue (60' R.O.W.) for the Northwest corner of this herein described tract to of land;
2. **Thence** with the existing South Right of Way line of Yuma Road, South 81°22'06" East a distance of 258.29 feet to the existing West Right of Way line of the Hidalgo County Irrigation District No. 2 Lateral "E" canal, described as Tract No.2, Volume 120, Page 546, of the Deed Records, Hidalgo County, Texas, for the Northeast corner of this herein described tract of land;
3. **Thence** with the Northwesterly line of the Hidalgo County Irrigation District No.2 Lateral "E", South 63°01'53" West a distance of 51.54 feet to a 5/8" iron pin with plastic cap stamped "R.O.W.S. PROP. COR." set in the South line of said of said Lot 1, Block 16, for the Southeast corner of this herein described tract of land;

4. **Thence** with the South line of said Lot 1, Block 16, across and through said 0.95 of an acre tract of land, with the South proposed Right of Way line of Yuma Avenue, North $81^{\circ}22'06''$ West a distance of 216.38 feet to the **Point of Beginning** and being a 7,120 square foot or 0.16 of an acre tract of land.

Bearings based on the Texas Coordinate System, South Zone, NAD83 (NA2011), adjusted to surface using a grid to surface adjustment factor of 1.00004.

A plat survey of even survey date herewith accompanies this description.

I, Kurt Schumacher, a Registered Professional Land Surveyor, hereby certify that the legal description hereon and the accompanying plat represent an actual survey made on the ground under my supervision.

 06/01/2016

Kurt Schumacher
Registered Professional Land Surveyor
Texas Registration No. 6333



LOT 06, BLOCK 15
STEELE AND PERSHING SUBDIVISION
(VOL. 08, PG. 115 D.R.H.C.)

LA ESTANCIA APARTMENTS SUBDIVISION.
(VOL. 46 PG. 126, M.R.H.C.)

YUMA AVE.
60' RIGHT-OF-WAY

7,120 SQ. FT., 0.16 AC.

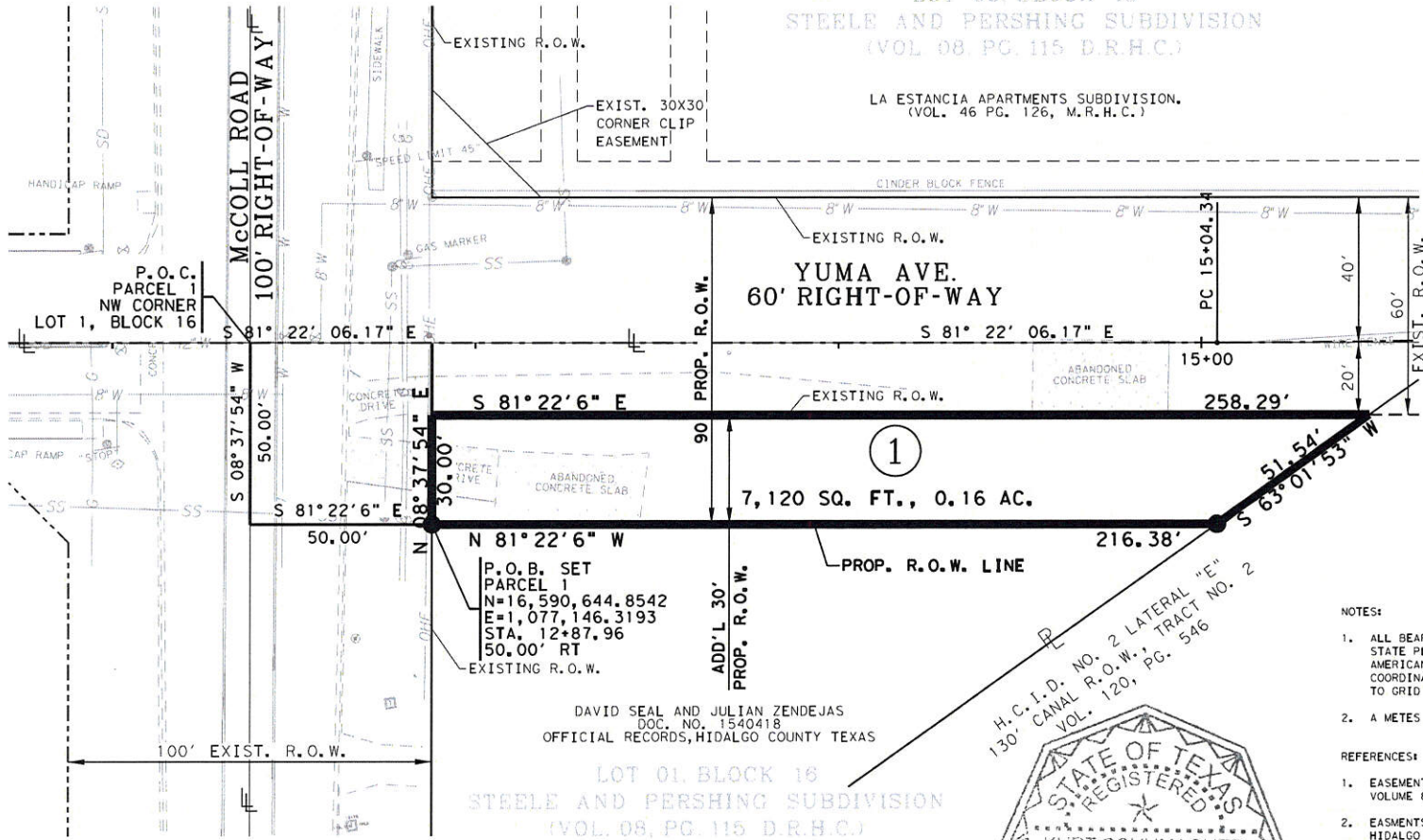
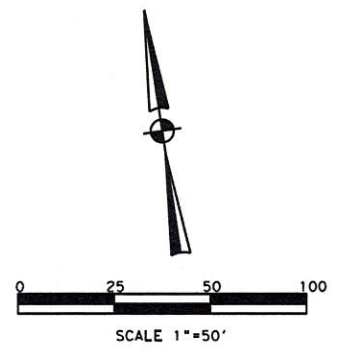

LEGEND:

- LOT LINE
- PROPERTY LINE
- PARCEL NUMBER
- RIGHT OF WAY
- POINT OF COMMENCING
- POINT OF BEGINNING
- HIDALGO COUNTY DEED RECORDS
- HIDALGO COUNTY MAP RECORDS
- HIDALGO COUNTY OFFICIAL RECORDS
- SET 5/8" IRON ROD WITH PLASTIC CAP
- STAMPED "ROWSS PROP. COR."
- FOUND 1/2" IRON ROD
- UNLESS OTHERWISE NOTED
- OVERHEAD ELECTRIC

**PLAT OF SURVEY
FOR PCT. 2 REGIONAL LINEAR PARK PROJECT**

A 7,120 SQ. FT. (0.16 AC.)
TRACT OF LAND SITUATED IN LOT 1, BLOCK 16
STEELE AND PERSHING SUBDIVISION,
OUT OF A CALLED 0.95 ACRES OF LAND
AS RECORDED IN DOCUMENT NO. 1540418,
OFFICIAL RECORDS, HIDALGO COUNTY, TEXAS.

EXHIBIT _____

NOTES:

1. ALL BEARINGS AND COORDINATES ARE BASED ON THE TEXAS STATE PLANE COORDINATE SYSTEM, SOUTH ZONE, NORTH AMERICAN DATUM OF 1983, NA2011. ALL DISTANCES AND COORDINATES SHOWN ARE SURFACE AND MAY BE CONVERTED TO GRID BY DIVIDING BY AN ADJUSTMENT FACTOR OF 1.00004.
2. A METES AND BOUNDS DESCRIPTION ACCOMPANIES THIS PLAT.

REFERENCES:

1. EASEMENTS AND CONDITIONS AS SHOWN ON THE MAP RECORDED IN VOLUME 8, PAGE 115, DEED RECORDS, HIDALGO COUNTY, TEXAS.
2. EASEMENTS, RIGHTS, RULES AND REGULATIONS IN FAVOR OF HIDALGO COUNTY IRRIGATION DISTRICT NO. 2.
3. EASEMENTS OR CLAIMS OF EASEMENTS WHICH ARE NOT OF PUBLIC RECORD.
4. ALL RIGHTS, TITLES, AND INTERESTS IN AND TO ALL PORTIONS OF THE PROPOSED INSURED LAND LYING WITHIN A DRAINAGE DITCH, DRAINAGE PIPE, DRAINAGE LINE, A CANAL OR IRRIGATION LINE AS MAY BE CLAIMED IN FEE BY HIDALGO COUNTY IRRIGATION DISTRICT NO.2.

TITLE COMMITMENT:
CHICAGO TITLE INSURANCE COMPANY
PROPOSED INSURED/BORROWER:
HIDALGO COUNTY
OWNER: DAVID SEAL AND JULIAN ZENDEJAS
GF No.: 0003166520
EFFECTIVE DATE:
MAY 4, 2016

RIGHT OF WAY SKETCH
SHOWING PROPERTY OF
PARCEL 1
PCT. 2 REGIONAL LINEAR PARK PROJECT



County: Hidalgo, Precinct 2
WA#22 Supplemental #2: Yuma Extension

Exhibit: A
FIELD NOTES FOR PARCEL 2

Being a 22,920 square foot or 0.53 of an acre tract of land, out of Lot 6, Block 15 and Lot 1, Block 16, Steele and Pershing Subdivision, as recorded in Volume 8, Page 115, of the Deed Records, Hidalgo County, Texas, and being out of Hidalgo County Irrigation District Canal Lateral "E" Right of Way, referenced as Tract No. 2, described in Volume 120, Page 546, Deed Records Hidalgo County, Texas, and referenced as Tract No. 19, as described in Volume 120, Page 550, of the Deed Records, Hidalgo County, Texas, said 0.53 of an acre tract of land being more particularly described by metes and bounds as follows;

1. **Beginning** at a ½" iron pin found (N=16,590,625.56, E=1,077,539.98) in the East line of said Lateral "E" Right of Way, for the Southeast corner of La Estancia Subdivision, as recorded in Volume 46, Page 126, of the Map Records, Hidalgo County, Texas, for the Northwest corner of this herein described tract of land;
2. **Thence** with the proposed 80.00 foot Right of Way line of Yuma Avenue, across and through said Lateral "E" Tract No.2, South 81° 22' 06" East, at a distance of 223.22 feet passing the Northwesterly line of said Lateral "E" Tract No. 19, continuing a total distance of 309.21 feet to a 5/8" iron pin with plastic cap stamped "R.O.W. PROP. COR." set in the Northwesterly line of a called 6.444 acre tract of land as described in Document No. 2695551, of the Official Records, Hidalgo County, Texas, for the Northeast corner of this herein described tract of land;
3. **Thence** departing the proposed 80.00 foot Right of Way line of Yuma Avenue, and with the Northwesterly line of said 6.444 acre tract of land, South 63°01'53" West, at a distance of 34.36 feet passing the existing North Right of Way line of Yuma Avenue, continuing a total distance of 68.71 feet to the South line of said Lot 6, Block 15, for the North line of said Lot 1, Block 15, and for a corner of this herein described tract of land;
4. **Thence** with the North line of said Lot 1, Block 16 and the South line of said Lot 6, Block 15, and the South line of said Lateral "E" Tract 19, North 81°22'06" West a distance of 85.89 feet to the Southeasterly line of said Lateral "E" Tract No. 2, for an interior corner of this herein described tract of land;
5. **Thence** departing the South line of said Lot 6, Block 15, across and through said Lot 1, Block 16 with the Southeasterly line of said Lateral "E" Tract No. 2, South 63°01'53" West a distance of 72.71 feet to a 5/8" iron pin with plastic cap stamped "R.O.W. PROP. COR." set in the existing South Right of Way line of Yuma Avenue, for the beginning of a curve concave to the Southwest, and for an exterior corner of this herein described tract of land;

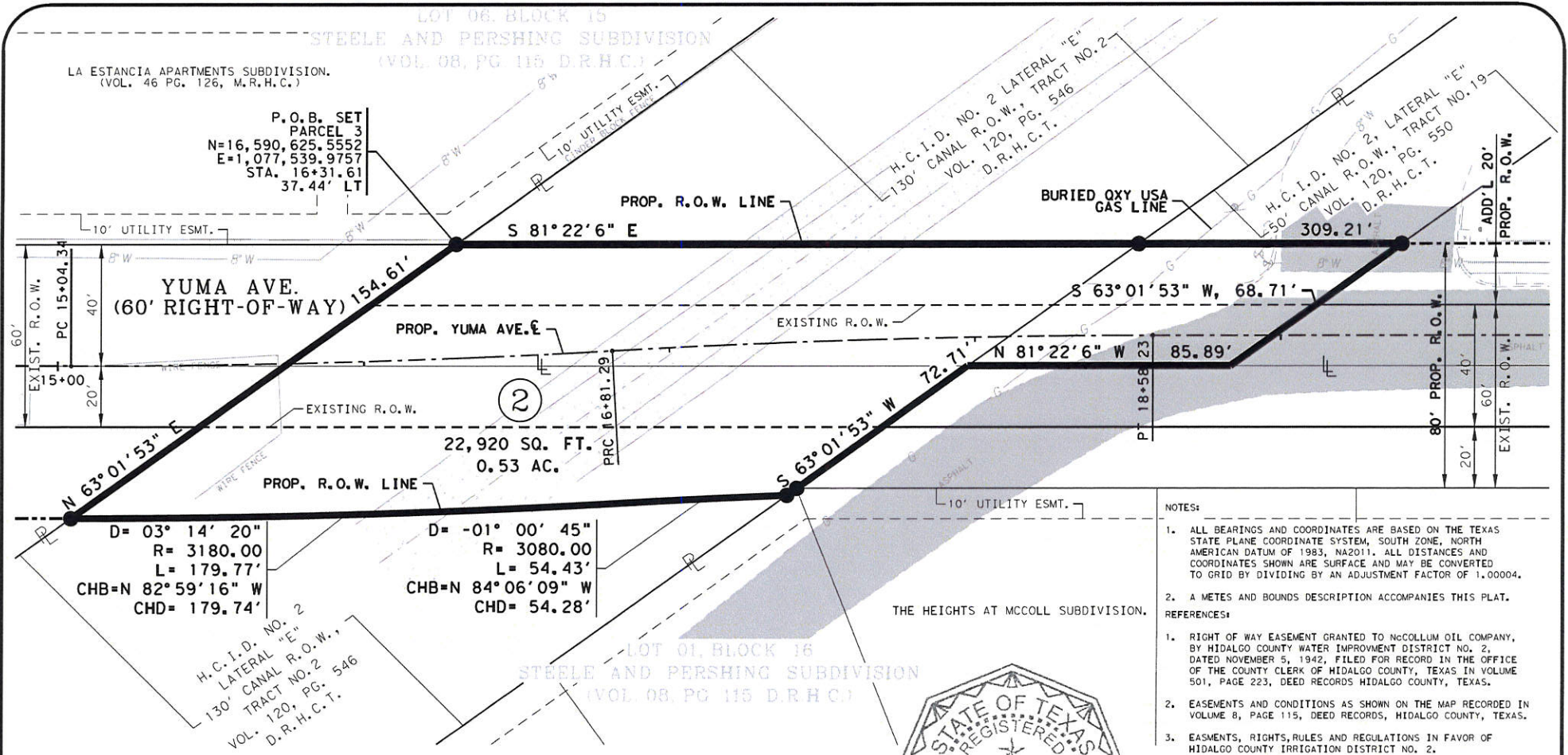

- NOTES:
1. ALL BEARINGS AND COORDINATES ARE BASED ON THE TEXAS STATE PLANE COORDINATE SYSTEM, SOUTH ZONE, NORTH AMERICAN DATUM OF 1983, NAD2011. ALL DISTANCES AND COORDINATES SHOWN ARE SURFACE AND MAY BE CONVERTED TO GRID BY DIVIDING BY AN ADJUSTMENT FACTOR OF 1.00004.
 2. A METES AND BOUNDS DESCRIPTION ACCOMPANIES THIS PLAT. REFERENCES:
 1. RIGHT OF WAY EASEMENT GRANTED TO MCCOLLUM OIL COMPANY, BY HIDALGO COUNTY WATER IMPROVEMENT DISTRICT NO. 2, DATED NOVEMBER 5, 1942, FILED FOR RECORD IN THE OFFICE OF THE COUNTY CLERK OF HIDALGO COUNTY, TEXAS IN VOLUME 501, PAGE 223, DEED RECORDS HIDALGO COUNTY, TEXAS.
 2. EASEMENTS AND CONDITIONS AS SHOWN ON THE MAP RECORDED IN VOLUME 8, PAGE 115, DEED RECORDS, HIDALGO COUNTY, TEXAS.
 3. EASEMENTS, RIGHTS, RULES AND REGULATIONS IN FAVOR OF HIDALGO COUNTY IRRIGATION DISTRICT NO. 2.
 4. EASEMENTS OR CLAIMS OF EASEMENTS WHICH ARE NOT OF PUBLIC RECORD.
 5. ALL RIGHTS, TITLES AND INTERESTS IN AND TO ALL PORTIONS OF THE PROPOSED INSURED LAND LYING WITHIN A DRAINAGE DITCH, DRAINAGE PIPE, DRAINAGE LINE, A CANAL OR AN IRRIGATION LINE AS MAY BE CLAIMED IN FEE BY THE HIDALGO COUNTY IRRIGATION DISTRICT NO. 2.
 6. PARCEL 2 ENCUMBERED BY EXISTING OXY USA GAS LINE.
 7. PRESCRIPTIVE RIGHTS FOR ROADS, PUBLIC OR PRIVATE, DITCHES, CANALS AND/OR UTILITIES WHICH ARE NOT A PART OF THE PUBLIC RECORD, BUT VISIBLE FROM AN INSPECTION OF THE PROPOSED INSURED LAND(S) OR REVEALED BY A PROPER SURVEY.



LEGEND:

- LOT LINE
- PROPERTY LINE
- PARCEL NUMBER
- RIGHT OF WAY
- POINT OF COMMENCING
- POINT OF BEGINNING
- HIDALGO COUNTY DEED RECORDS
- HIDALGO COUNTY MAP RECORDS
- HIDALGO COUNTY OFFICIAL RECORDS
- SET 5/8" IRON ROD WITH PLASTIC CAP
- STAMPED "ROWSS PROP. COR."
- FOUND 1/2" IRON ROD UNLESS OTHERWISE NOTED
- OVERHEAD ELECTRIC

- R.O.W.
- P.O.B.
- H.C.D.R.
- H.C.M.R.
- H.C.O.R.
- OHE

PLAT OF SURVEY FOR PCT. 2 REGIONAL LINEAR PARK PROJECT

A 22,920 SQ. FT. (0.53 AC.) TRACT OF LAND SITUATED IN LOT 1, BLOCK 16 AND LOT 6, BLOCK 15 STEELE AND PERSHING SUBDIVISION, OUT OF H.C.I.D. NO.2 CANAL LATERAL "E" AS DESCRIBED IN VOLUME 120, PAGE 546 DEED RECORDS, HIDALGO COUNTY, TEXAS.

EXHIBIT _____

TITLE COMMITMENT:
 CHICAGO TITLE INSURANCE COMPANY
 PROPOSED INSURED/BORROWER: HIDALGO COUNTY
 OWNER: HIDALGO COUNTY IRRIGATION DISTRICT NO. 2
 GF No.: 0003166521
 EFFECTIVE DATE: MAY 04, 2016

RIGHT OF WAY SKETCH
 SHOWING PROPERTY OF
 PARCEL 2
 PCT. 2 REGIONAL LINEAR PARK PROJECT

900 S. STEWART RD. SUITE 113
 MISSION, TEXAS 78572
 TEL.: (956) 424-3336
 FAX.: (956) 424-3132

TBPLS REG. FIRM# 10193886

County: Hidalgo, Precinct 2
WA#22 Supplemental #2: Yuma Extension

Exhibit: A
FIELD NOTES FOR PARCEL 3

Being a 3,490 square foot or 0.08 of an acre tract of land, out of Lot 6, Block 15, Steele and Pershing Subdivision, as recorded in Volume 8, Page 115, of the Deed Records, Hidalgo County, Texas, and being out of a called 6.444 acre tract of land, conveyed by warranty Deed with Vendor's Lien dated March 10, 2016 to Oscar A. Tamez Guerra, as described in Document No. 2695551, of the Official Records, Hidalgo County, Texas, said 0.08 of an acre tract of land being more particularly described by metes and bounds as follows;

Commencing from the Southeasterly line of Hidalgo County Irrigation District No.2 Lateral "E", referenced as Tract No. 19, as described in Volume 120, Page 550, of the Deed Records, Hidalgo County, Texas, for the North corner of said called 6.444 of an acre tract of land;

Thence with the Southeasterly line of said Lateral "E" Tract No. 19 and the Northwesterly line of said called 6.444 of an acre tract of land, South 63° 01' 53" West, a distance of 1021.94 feet to a 5/8" iron pin with plastic cap stamped "R.O.W. PROP. COR." (N=16590579.148, E=1,077,845.684) set in the North proposed 80.000 foot Right of Way line of Yuma Avenue, for the Northwest corner and **Point of Beginning** of this herein described tract of land;

1. **Thence** departing the Southeasterly line of said Lateral "E" Tract No.19, across and through said called 6.444 acre tract of land with the North proposed Right of Way line of Yuma Avenue, South 81°22'06" East, a 160.55 feet to a 5/8" iron pin with plastic cap stamped "R.O.W. PROP. COR." set for the Northeast corner of this herein described tract of land;
2. **Thence** South 08°37'54" West a distance of 20.00 feet to the North existing Right of Way line of Yuma Avenue, for the Southeast corner of this herein described tract of land;
3. **Thence** with the North existing Right of Way line of Yuma Avenue, North 81°22'06" West a distance of 188.48 feet to the Southeasterly line of said Lateral "E" Tract No. 19, for the Southwest corner of this herein described tract of land;

4. **Thence** with the Southeasterly line of said Lateral "E" Tract No.19, North 63° 01' 53" East a distance of 34.36 feet to the **Point of Beginning** and being a 3,490 square foot or 0.08 of an acre tract of land;

Bearings based on the Texas Coordinate System, South Zone, NAD83 (NA2011), adjusted to surface using a grid to surface adjustment factor of 1.00004.

A plat survey of even survey date herewith accompanies this description.

I, Kurt Schumacher, a Registered Professional Land Surveyor, hereby certify that the legal description hereon and the accompanying plat represent an actual survey made on the ground under my supervision.

 05/31/2016

Kurt Schumacher
Registered Professional Land Surveyor
Texas Registration No. 6333

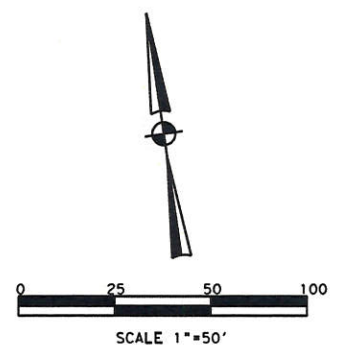
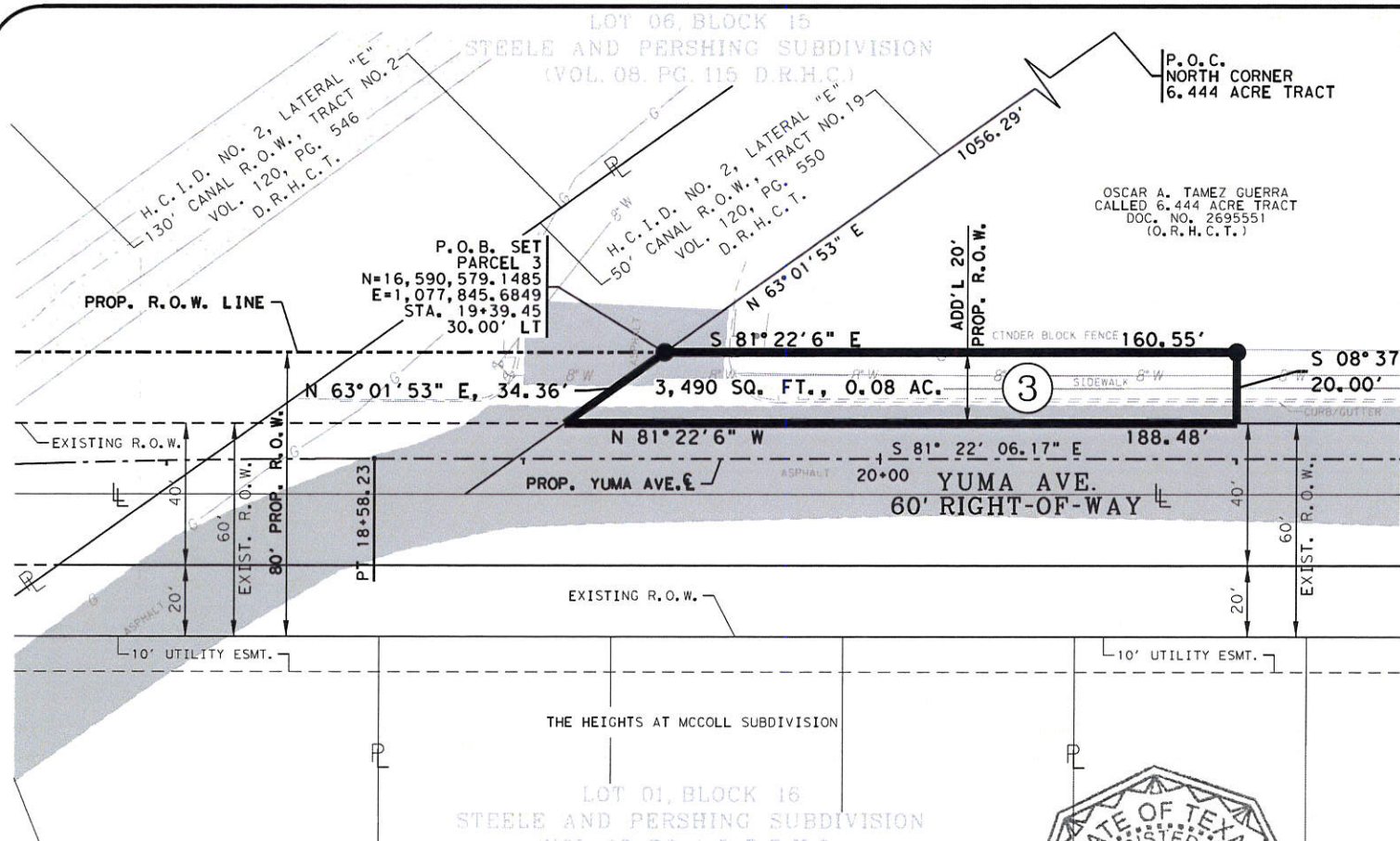

- NOTES:
1. ALL BEARINGS AND COORDINATES ARE BASED ON THE TEXAS STATE PLANE COORDINATE SYSTEM, SOUTH ZONE, NORTH AMERICAN DATUM OF 1983, NA2011. ALL DISTANCES AND COORDINATES SHOWN ARE SURFACE AND MAY BE CONVERTED TO GRID BY DIVIDING BY AN ADJUSTMENT FACTOR OF 1.00004.
 2. A METES AND BOUNDS DESCRIPTION ACCOMPANIES THIS PLAT.

- REFERENCES:
1. RIGHT OF WAY EASEMENT GRANTED TO McCOLLUM OIL COMPANY, BY HIDALGO COUNTY WATER IMPROVEMENT DISTRICT No. 2, DATED NOVEMBER 5, 1942, FILED FOR RECORD IN THE OFFICE OF THE COUNTY CLERK OF HIDALGO COUNTY, TEXAS IN VOLUME 501, PAGE 223, DEED RECORDS HIDALGO COUNTY, TEXAS.
 2. EASEMENTS AND CONDITIONS AS SHOWN ON THE MAP RECORDED IN VOLUME 8, PAGE 115, DEED RECORDS, HIDALGO COUNTY, TEXAS.
 3. EASEMENTS, RIGHTS, RULES AND REGULATIONS IN FAVOR OF HIDALGO COUNTY IRRIGATION DISTRICT NO. 2.
 4. EASEMENTS OR CLAIMS OF EASEMENTS WHICH ARE NOT OF PUBLIC RECORD.
 5. ALL RIGHTS, TITLES AND INTERESTS IN AND TO ALL PORTIONS OF THE PROPOSED INSURED LAND LYING WITHIN A DRAINAGE DITCH, DRAINAGE PIPE, DRAINAGE LINE, A CANAL OR AN IRRIGATION LINE AS MAY BE CLAIMED IN FEE BY HIDALGO COUNTY IRRIGATION DISTRICT NO. 2.

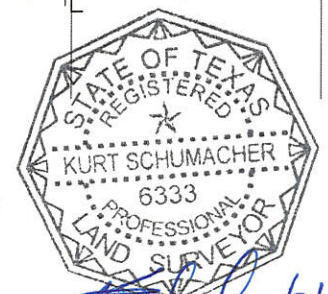

Kurt Schumacher
05/31/2016

LEGEND:

- LOT LINE
- PROPERTY LINE
- PARCEL NUMBER
- RIGHT OF WAY
- POINT OF COMMENCING
- POINT OF BEGINNING
- HIDALGO COUNTY DEED RECORDS
- HIDALGO COUNTY MAP RECORDS
- HIDALGO COUNTY OFFICIAL RECORDS
- SET 5/8" IRON ROD WITH PLASTIC CAP
- STAMPED "ROWSS PROP. COR."
- FOUND 1/2" IRON ROD UNLESS OTHERWISE NOTED
- OVERHEAD ELECTRIC

- R.O.W.
- P.O.C.
- P.O.B.
- H.C.D.R.
- H.C.M.R.
- H.C.O.R.
-
-
- OHE—

PLAT OF SURVEY
FOR PCT. 2 REGIONAL LINEAR PARK PROJECT
 A 3,490 SQ. FT. (0.08 AC.)
 TRACT OF LAND SITUATED IN LOT 1, BLOCK 16
 STEELE AND PERSHING SUBDIVISION,
 OUT OF A CALLED 6.444 ACRES OF LAND
 AS RECORDED IN DOCUMENT NO. 2695551,
 OFFICIAL RECORDS, HIDALGO COUNTY, TEXAS.

EXHIBIT _____
 PAGE 3 OF 3

TITLE COMMITMENT:
 CHICAGO TITLE INSURANCE COMPANY
 PROPOSED INSURED/BORROWER:
 HIDALGO COUNTY
 OWNER: OSCAR A. TAMEZ GUERRA
 GF No.: 0003166522
 EFFECTIVE DATE:
 MAY 12, 2016

RIGHT OF WAY SKETCH
 SHOWING PROPERTY OF
PARCEL 3
 PCT. 2 REGIONAL LINEAR PARK PROJECT

ROW SURVEYING SERVICES, LLC.

900 S. STEWART RD. SUITE 13
 MISSION, TEXAS 78572
 TEL: (956) 424-3335
 FAX: (956) 424-3132

TBPLS REG. FIRM# 10193886

STATE OF TEXAS §

COUNTY OF HIDALGO §

APPROVAL OF INTERLOCAL COOPERATION AGREEMENT PROJECT

In accordance with Texas Government Code §791.014, Hidalgo County, Texas, acting by and through the Hidalgo County Commissioners Court, has been advised of a proposed project regarding acquisition of road right of way for Yuma Avenue west to McColl Rd., which is within the City limits of the City of McAllen, Texas and which benefits the County Regional Linear Park Project through an Interlocal Cooperation Agreement to be entered into with Hidalgo County and the City of McAllen, Texas.

By vote on _____ 2016, the Hidalgo County Commissioners Court has approved the Project identified above.

By: _____
Ramon Garcia, County Judge

ATTEST:

Arturo Guajardo, County Clerk

APPROVED AS TO FORM:

Atlas, Hall & Rodriguez, L.L.P.

By: _____
Stephen L. Crain