

THE STATE OF TEXAS §
§
COUNTY OF HIDALGO §

SERVICE CONTRACT
C-17-097-03-21

THIS CONTRACT is made and entered into this **21st** day of **March, 2017** by and between the **County of Hidalgo, Texas** ("County") and **Republic Services, Inc.** ("Company").

WHEREAS, Company responded to notices for Request for Sealed Quotes (RFSQ) for **"Garbage Collection at New San Carlos CRC" (on an as needed basis)** (the "Services"); and

WHEREAS, Company submitted a sealed quote to provide services in accordance with Exhibit "A" Request for Sealed Quotes (RFSQ) Procurement Packet attached hereto respectively, and incorporated herein for all purposes of (the "RFSQ"); and;

WHEREAS, in recognition of and in consideration of Company's agreement to perform the Services in accordance with Specifications within Exhibit "A" Request for Sealed Quotes (RFSQ) Procurement Packet, the Commissioners Court of County awarded the sealed quote to Company.

NOW, THEREFORE, in mutual consideration of the foregoing and the further consideration of the following, the parties hereto agree as follows:

1. County and Company hereby agrees that this Contract is entered into in order to provide the Services to **Hidalgo County**. This Contract does not extend to any third parties any duties or benefits conferred in any manner hereunder or otherwise.

2. Company hereby promises and agrees to render and provide, during the term of this Contract, and shall be obligated to render and provide the services in accordance with the specifications contained in Exhibit "A" Request for Sealed Quotes (RFSQ) Procurement Packet within **Hidalgo County** following a request for Services by the **Hidalgo County Precinct No. 4**.

Republic Services, Inc.
Garbage Collection at New San Carlos CRC-Pct. 4

C-17-097-03-21

Company agrees in performing the Services that it will use proper professional standards, comply with any and all appropriate laws and regulations in providing the Services, and devote such time as is necessary to safely and efficiently provide the Services. Further Hidalgo County reserves the right to request these services from other sources other than the successful vendor and shall not be in violation of any terms or conditions of said contract.

3. This Contract shall be for a period of **one (1) year**, commencing on **March 21, 2017** and expiring on **March 20, 2018**. Hidalgo County also reserves the right to continue this sealed quote for an additional sixty (60) day grace period at the end of the contract term for unforeseen delay of award for the next term and contingent upon cost remaining unchanged.

4. As a condition of this Contract, Company shall hold and maintain throughout the term of this Contract all licenses and permits required, or which may be required by any authority during the term hereof to provide the Services.

5. All trucks or vehicles operated by the Company to perform the Services shall contain all equipment required by any authority to operate on streets and roads and all persons in the employ of Company who operate such trucks or vehicles shall have the required licenses, qualifications, skill and expertise to perform such Services and shall comply with all laws, rules and regulations prescribed by any agency or authority having jurisdiction with regard to the operation of such trucks or vehicles in providing the Services.

6. As consideration for rendering the Service provided for in this Contract, the County agrees to pay Company the amounts specified in Exhibit "B" attached hereto payable against written invoice submitted by Company.

7. Company shall provide insurance in force on all its vehicles and all persons connected with providing services under this Contract naming County as an additional insured (with the

coverages and in the amounts described on Exhibit "C" attached hereto and incorporated herein at this point for all purposes), and shall furnish to County certificates of such insurance coverage.

8. Company shall provide a sufficient number of trucks, vehicles, personnel and equipment available to safely and efficiently provide the Services.

9. Company shall indemnify and hold harmless County, its elected officials, employees and agents from any and all claims, damages, losses, and expenses including attorney's fees for the defense of any action against County arising out of, resulting from, or connected with the provision of the Service by Company under this Contract. Said indemnity shall cover any act or failure to act by the Company, its agents or employees.

10. This Contract shall not be assignable in whole or in part by either party without prior written consent of the other party.

11. It is expressly agreed that this Contract and the performance by the parties hereunder does not create any agency relationship or master-servant relationship that County has no supervision of the performance of the Services provided by Company, and that Company is an independent contractor under this Contract.

12. Any notice required or permitted to be given hereunder shall be in writing and shall be delivered personally or sent by certified mail, postage prepaid, as set forth below:

If to County: County of Hidalgo
Attn: County Judge
100 East Cano, 2nd Floor (Admin. Bldg.)
Edinburg, Texas 78539

If to Company: **Republic Services, Inc.**
 Attn: Maribel Nieto
 9402 West Expressway 83
 Harlingen, Texas 78552

13. In case any one or more of the provisions contained in this Agreement shall for any reason be held to be invalid, illegal or unenforceable in any respect, such invalidity, illegality, or unenforceability shall not affect any other provision thereof and this Agreement shall be construed as if such invalid, illegal, or unenforceable provision had never been contained herein.

14. This Agreement may be terminated by County without cause upon thirty (30) days written notice.

15. This Agreement shall be binding upon and inure to the benefit of and be enforceable by the parties hereto and their respective heirs, executors, administrators, legal representatives, successors, and assigns where permitted by this Agreement.

16. This Agreement shall be governed by and construed in accordance with the laws of the State of Texas and shall be performable in Hidalgo County.

17. **Commitment of Current Revenues Only.** In the event that, during any term hereof, the Commissioners Court does not appropriate sufficient funds to meet the obligations of County under this Agreement, County may terminate this Agreement upon ninety (90) days written notice to Company. County agrees, however, to use reasonable efforts to secure funds necessary for the continued performance of this Agreement. The parties intend this provision to be a continuing right to terminate this Agreement at the expiration of each budget period of County pursuant to the provisions of Tex. Loc. Govt. Code Ann. ' 271.903 (Vernon Supp. 1996).

18. **Entire Agreement.** This Agreement contains the entire contract between the parties hereto, and each party acknowledges that neither has made (either directly or through any agent or representative) any representation or agreement in connection with this Agreement not specifically set forth herein. This Agreement may be modified or amended only by agreement in writing executed by the parties hereto, and not otherwise.

19. **Immunities.** Nothing in this Agreement is intended to and County does not hereby waive, release or relinquish any right to assert any of the defenses County enjoys by virtue of the state or federal constitution, laws, rules or regulations, and any sovereign, official or qualified immunity available to County as to any claim or action of any person, entity, or individual against County.

WITNESS our hands in duplicate originals this ____ day of _____, 2017.

Approved by Commissioner's Court: _____, 2017.

APPROVED AS TO FORM
Atlas, Hall & Rodriguez, L.L.P.

By: _____
Stephen L. Crain, Attorney

COUNTY OF HIDALGO

ATTEST:

By: _____
Ramon Garcia, County Judge

By: _____
Arturo Guajardo, Jr., County Clerk

COMPANY: REPUBLIC SERVICES, INC.

By: _____

Printed Name: Maribel Nieto

Title: Inside Sales Representative

EXHIBIT "A"
REQUEST FOR SEALED QUOTES (RFSQ) PROCUREMENT PACKET



Hidalgo County Purchasing Office
2812 S. Business Highway 281
New Administration Building
Edinburg, Texas 78539
(956) 318-2626/ Fax: (956) 292-7612

February 23, 2017

Bidder's name

Address

City

State, Zip Code

Re: **HIDALGO COUNTY PRECINCT NO. 4**
Request for Sealed Quotes -**"Garbage Collection at New San Carlos CRC"**
RFSQ No: 2017-097-03-06-SGS

Dear Gentleman/Ladies:

Enclosed, please find the Request for Sealed Quotes (RFSQ) packet. **Modifications and new requirements** have been added and implemented. Carefully read and review all instructions, Requirements and Specifications.

Hidalgo County Purchasing Department welcomes and appreciates your participation in the Request for Sealed Quotes process.

If any further assistance is required, please do not hesitate to call the Purchasing Department 956/318-2626 x 4860.

Sincerely,

Sandy Suarez, Buyer II
Hidalgo County Purchasing Department

sgs

Enclosures



HIDALGO COUNTY PURCHASING
2812 S. Business Highway 281
Edinburg, Texas 78539
(956) 381-2626/ Fax: (956) 292-7612

REQUEST FOR SEALED QUOTES (RFSQ)
HIDALGO COUNTY PRECINCT NO. 4
“GARBAGE COLLECTION AT NEW SAN CARLOS CRC”
RFSQ NO: 2017-097-03-06-SGS

TABLE OF CONTENTS

ITEM	DESCRIPTION	NO. OF PAGES
1.	Request For Sealed Quotes Letter	1
2.	Request for Sealed Quotes, Legal Notice	9
3.	Table of Contents	1
4.	Exhibit A, Specifications / Attachment A-1	6-1
5.	Exhibit B	2
6.	Exhibit C, Insurance Requirements	4
7.	Exhibit D, (CIQ) Conflict of Interest Questionnaire	2
8.	Exhibit E, Vendor/Bidder Application and W-9 form(s)	6
9.	Exhibit F, Certification Regarding Debarment	1
10.	Exhibit G, Title VI Appendices “A” through “E”	6
10.	RFSQ Submittal Checklist	1
11.	Draft Agreement	9

The above mentioned items shall be found in this Request for Sealed Quotes-(RFSQ) - packet that is attached herewith. Should you find that any of the listed items are not attached in its entirety, please contact The Purchasing Dept. by calling (956) 318-2626, to advise us of the missing documentation, and Purchasing will forward information either through facsimile, e-mail or by U.S. Mail.

Thank you.

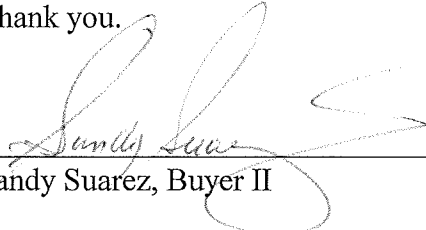

Sandy Suarez, Buyer II

February 23, 2017
Date

RFSQ: 2017-097-03-06-SGS

Name: Sandy Suarez, Buyer II

Tel. No: (956) 318-2626 ext 4860

REQUEST FOR SEALED QUOTES

HIDALGO COUNTY PRECINCT NO. 4

“GARBAGE COLLECTION AT NEW SAN CARLOS CRC”

RFSQ NO.: 2017-097-03-06-SGS

DUE DATE:
MARCH 06, 2017
At 11:00 A.M.

Contact Person:

Sandy. Suarez, Buyer II

Hidalgo County Purchasing Department

Physical Address: 2802 S. Business Hwy. 281 - Administration Building

Mailing/Postal Address: 2812 S. Business Hwy. 281

Edinburg, Texas 78539

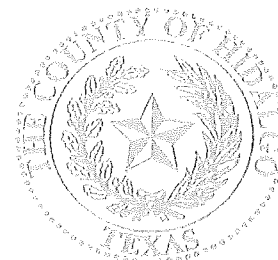

Form HCPD-03

LEGAL NOTICE

RFSQ No: 2017-097-03-06-SGS

1. Sealed quotes will be received for HIDALGO COUNTY PRECINCT NO. 4–“GARBAGE COLLECTION AT NEW SAN CARLOS CRC” in accordance with the specifications attached as Exhibit "A" hereto. RFSQs should address all specifications set forth. Participants may suggest substitutions of features which they feel would be in the best interest of Hidalgo County ("County"). Strong rationale must be presented for any deviation from the specifications. Hidalgo County reserves the right to reject the deviation and its effect on the overall RFSQ.

2. All RFSQs are required with the Participants name and return address clearly typed/printed on upper left hand corner and the proper notation clearly typed/printed on the lower left hand corner of the envelope and/or package: RFSQ No: 2017-097-03-06-SGS - HIDALGO COUNTY PRECINCT NO. 4–“GARBAGE COLLECTION AT NEW SAN CARLOS CRC” and in County's Purchasing Department, physical address: 2802 S. Business 281 and a mailing address: 2812 S. Business Hwy 281, Administration Building, Edinburg, Texas, ON OR BEFORE MONDAY, MARCH 06, 2017 at 11:00 A.M. FACSIMILES, EMAILS OR LATE ARRIVALS WILL NOT BE ACCEPTED. ANY RFSQ RECEIVED AFTER THAT TIME WILL NOT BE OPENED AND WILL BE RETURNED. OVERNIGHT MAIL MUST ALSO BE PROPERLY LABELED ON THE OUTSIDE OF EXPRESS ENVELOPE OR PACKAGE IN REFERENCE TO RFSQ No: 2017-097-03-06-SGS. HIDALGO COUNTY PRECINCT NO. 4 –“GARBAGE COLLECTION AT NEW SAN CARLOS CRC” Hidalgo County reserves the right to refuse and reject any/all RFSQs and to waive any/all formalities or technicalities, or to accept the RFSQ considered the best and most advantageous to Hidalgo County.

Additionally, all forms listed below must be properly executed and included with your quote:

1. **Legal Notice (See page 9);**
 2. **Quote Page – Procurement Form – Areas of Specialization (See Exhibit “B”);**
 3. **Insurance pages with Acknowledgment Forms (See Exhibit “C”);**
 4. **Form CIQ-Conflict of interest Questionnaire (See Exhibit “D”);**
 5. **Vendor Bidder Application & W-9 forms (See Exhibit “E”);**
 6. **Certification Regarding Debarment (See Exhibit “F”); and**
 7. **SAMS.gov Registration Acknowledgement (See Number 18 below).**
-
3. Hidalgo County reserves the right to: A.) separate and accept, or eliminate any item(s) listed under this RFSQ that it deems necessary to accommodate budgetary and/or operational requirements; B.) reject any or all RFSQs submitted and further reserves the right to design the evaluation criteria to be used in selecting the lowest and best RFSQ for approval; and C.) award the RFSQ to one Participant or to multiple Participants if the County determines it is in its best interest to do so. D. award the contract to the responsible bidder who submits the lowest and best bid. "Lowest and best" means a bid or offer providing the best value considering associated direct and indirect costs, including transport, maintenance, reliability, life cycle, warranties, and customer service after a sale.

4. The Participant shall not substitute items named in the RFSQ without the express written consent of Hidalgo County. Failure of the delivered item to perform as specified or failure to meet the stated delivery schedule shall release Hidalgo County from all obligations to the contracting party with regard to the item(s) in question. In such event, County may elect to award the contract to the next-lowest responsible Participant, or to reject all RFSQs and re-advertise.
5. For work to be performed at a County owned or operated location, each Participant shall, in its sole discretion, visit the job site before preparing the RFSQ and thoroughly familiarize himself/herself with existing conditions. Participant should take field dimensions and note all circumstances which affect the dollar amount of the RFSQ.
6. Descriptive specifications are referenced in this document to indicate the general kind and quality of equipment desired by Hidalgo County. Due to various styles and models of equipment, Participants are required to include illustrations, specifications, explanation of warranties, and service data with their RFSQ including catalogue numbers and any necessary references.
7. No RFSQ may be withdrawn within thirty (30) days from the scheduled time to open RFSQs.
8. Proposed prices are to remain firm for a minimum of ninety (90) days after RFSQ opening.
9. Any interpretations, amendments, corrections or changes to this RFSQ document must be in a written addendum and signed by the County Judge or his designee. Addenda will be mailed to all who are known to have received a copy of the Request for RFSQs. Participants shall acknowledge receipt of all addenda as a part of their RFSQ.
10. County reserves the right to accept or reject any or all RFSQs.
11. Costs are to be net F.O.B., County Prepaid.
12. County is exempt from Federal Excise Tax, State Tax and Local Tax. Do Not include tax in cost figure. If it is determined that tax was included in the cost figures it will not be included in the tabulation of any awards. Tax exemption certificates will be furnished upon request.
13. Funds for this procurement have been provided through the County budget for this fiscal year only. County, on an annual basis, has the right to reconsider a contract during the budget process for ensuing years if financial resources of County are insufficient to meet the liabilities of said contract. The award of a RFSQ or contract hereunder will not be construed to create a debt of the County which is payable out of funds beyond the current fiscal year.
14. Upon award and prior to execution of a contract, Sole Proprietorships are required to submit a copy of their social security card to the Hidalgo County Auditors Office in order to establish an account with the County. All awarded vendors must submit a completed W-9 and a copy of their Federal ID Number Certificate.
15. **DELIVERY INSTRUCTIONS:**

18. ~~RFSQ or Performance Bond; Payment under Contract. ; if applicable for public works projects):~~.

~~If the contract proposed is for the construction of public works or is for a contract exceeding \$100,000, all Participants shall furnish a good and sufficient RFSQ bond in the amount of five percent of the total contract price. A RFSQ bond must be executed with a surety company authorized to do business in Texas. All Participants are also required to furnish a certification or acknowledgment stating that the contractor or vendor is free from suspension or debarment pursuant to federal regulation 45CFR Part 76. Register at SAMs System for Award Management @ www.sam.gov.~~

- ~~• Together with the signing of a contract or issuance of a purchase order following the acceptance of a RFSQ, and prior to commencement of the actual work, the Participant shall furnish a performance bond to the County for the full amount of the contract, if that contract exceeds \$50,000.~~
- ~~• If the contract is for \$50,000 or less, no money will be paid to the contractor until completion and acceptance of the work or the fulfillment of the purchase obligation to the County, and, if applicable, the receipt by County of satisfactory evidence that all subcontractors and material men have been paid.~~
- ~~• If a contract is for the construction, alteration or repair of public buildings or public works, the contractor shall provide a payment bond for a contract in excess of Twenty Five Thousand Dollars (\$25,000.00), as required by Tex. Govt. Code Ch. 2253.~~
- ~~• For requirements contracts, bond requirements are determined by applying the proposed unit price to the estimated quantities included in the specifications.~~

19. TITLE VI NOTICE/ NONDISCRIMINATION

a. "The County of Hidalgo, in accordance with the provisions of Title VI of the Civil Rights Act of 1964 (78 Stat.252, 42 U.S.C. §§2000d to 2000d-4) and the Regulations, hereby notifies all bidders that it will affirmatively ensure that any contract entered into pursuant to this advertisement, disadvantaged business enterprises will be afforded full and fair opportunity to submit bids in response to this invitation and will not be discriminated against on the grounds of race, color, or national origin in consideration for an award."

b. The appropriate clauses of Appendices "A" through "E" as delineated in the USDOT Standard Title VI/Nondiscrimination Assurances - Specific Assurances are hereby incorporated by reference as applicable. Title VI Appendices "A" through "E" are attached as **Exhibit "G"**.

c. Bidder will attach all applicable notices to which it is obligated to provide or submit as part of the bid, including Form FHWA 1273 to be submitted by all contractors and subcontractors in relation to construction contracts.

20. **ETHICAL STANDARDS:**

- . It shall be a breach of ethics to offer, give or agree to give any elected official, department head or employee, or former elected official, department head or employee, of the County, or for any elected official, department head or employee or former elected official, department head or employee of the County, to solicit, demand, accept or agree to accept from another person, entity or organization, a gratuity or an offer of employment in connection with any decision, approval, disapproval, recommendation, preparation or any part of a program requirement or purchase request, influencing the content of any specification or procurement standard, rendering of advice, investigation, auditing, or in any other advisory capacity in any proceeding or application, request for ruling, determination, claim or controversy, or other particular matter pertaining to any program requirement or a contract or subcontract, or to any solicitation or proposal therefore pending before any department or agency of the County.
- . It shall be a breach of ethics for any payment, gratuity or offer of employment to be made by or on behalf of a subcontractor under a contract to the prime contractor or higher tier subcontractor for any contract for the County, or any person associated therewith, as an inducement for the award of a subcontract or order.
- . No public official shall have an interest in a contract awarded hereunder except in accordance with Tex. Loc. Govt. Code Chapter 171.

NOTICE:

ALL COMMUNICATIONS BY A VENDOR TO THE COUNTY, ITS OFFICIALS, AND DEPARTMENT HEADS REGARDING THIS PROCUREMENT SHALL BE DONE THROUGH THE HIDALGO COUNTY PURCHASING DEPARTMENT.

21. Disclosure of Conflict of Interest

- . Effective January 1, 2016, Chapter 176 of the Texas Local Government Code requires that any vendor, person, consultant or contractor considering doing business with Hidalgo County (“the County”) to disclose in the Conflict of Interest Questionnaire (the “CIQ”) attached as Exhibit D, the vendor, person, consultant or contractor’s affiliation or business relationship that might cause a conflict of interest with the County. By law, the CIQ must be filed with the Hidalgo County Clerk’s Office no later than the seventh business day after the date the person becomes aware of facts that require that statement to be filed. The disclosure requirement applies to a person or business who contracts or seeks to contract with Hidalgo County for the sale or purchase of property, goods or service. Any purchase order or contract resulting from this process shall be considered null and void if the successful participant fails to comply with Texas Local Government Code Chapter 176. Vendors, consultants, contractors and others who desire to conduct business with Hidalgo County are encouraged to refer to Texas Local Government Code Chapter 176 for the details of this law. An offense under Texas Local Government Code Chapter 176 is a Class C Misdemeanor

Completed Form CIQ must be submitted to the Hidalgo County Clerk's Office located at 100 N. Closner, Edinburg, Texas 78539 - Hidalgo County Courthouse.

COMPLETION AND SUBMISSION OF FORM CIQ IS THE SOLE RESPONSIBILITY OF THE PROSPECTIVE RESPONDENT. QUESTIONS REGARDING COMPLIANCE SHOULD BE DIRECTED TO YOUR LEGAL COUNSEL

22. CERTIFICATE OF INTERESTED PARTIES (FORM HB1295)

As of January 1, 2016, to comply with Texas Government Code Section §2252.908, and the rules issued by the Texas Ethics Commission found in Title 1, Section 46.1, 46.3 and 46.5 of the Texas Administrative Code, we have updated and revised our RFSQ packet. In accordance with these requirements, business must submit a completed Certificate of interested Parties Form 1295 to the County before the County may enter into a contract with the business entity. In box 3 of Form 1295, you will provide the RFSQ No.: 2017-097, as shown on the packet. Once completed and filed with the Texas Ethics Commission, Form 1295 must be printed and signed in the presence of a notary and submitted to our office either by facsimile transmission to (956) 292-7612 or via email to sandy.suarez@co.hidalgo.tx.us. Hidalgo County cannot enter into a contract until Form 1295 is submitted. Therefore, failure to timely submit Form 1295 signed and notarized may result in delay of award. Full instructions for completion and submittal of Form 1295 may be found on the Texas Ethics Commission website:

<https://www.ethics.state.tx.us/tec/1295-Info.htm>

THE AWARDED VENDOR WILL HAVE THIRTY (30) DAYS TO SUBMIT THE SIGNED NOTARIZED FORM 1295. HIDALGO COUNTY CANNOT ENTER INTO A CONTRACT UNTIL FORM 1295 IS SUBMITTED.

23. If during the life of any contract or RFSQ awarded, the successful Participant's net prices generally available to other customers for items awarded herein are reduced below the contracted price, it is understood and agreed that the benefits of such reduction shall be extended to County.
24. RFSQs, and all goods and services provided there under, shall comply with all federal, state and local laws concerning this type(s) of goods and/or services.
25. Minimum Standards For Responsible Prospective Participants: A prospective Participant must affirmatively demonstrate Participant's responsibility. A prospective Participant, by submitting a RFSQ, represents to County that it meets the following requirements:
- Possess or is able to obtain adequate financial resources as required to perform under the RFSQ;
 - Be able to comply with the required or proposed delivery schedule;
 - Have a satisfactory record of performance;
 - Have a satisfactory record of integrity and ethics;
 - Be otherwise qualified and eligible to receive an award.
26. Successful Participant will pay or cause to be paid, without cost or expenses to County, all FICA, FUTA/SUTA and Federal Income Withholding Taxes of all employees, and all wages

and benefits as required by Federal or State law. Successful Participant's officers, agents and/or employees will not be entitled to any benefits of an employee or elected official of County, including, but not limited to, benefits associated with County's civil service system.

27. Any contract award to a successful Participant will be in effect until (a) the contract expires, (b) delivery and acceptance of products, and/or performance of services ordered, or (c) terminated by County with thirty day's written notice prior to cancellation.
28. County reserves the right to enforce performance of any contract awarded hereunder in any manner prescribed by law or deemed to be in the best interest of the County in the event of breach or default by successful Participant; County reserves the right to terminate any contract immediately in the event a successful Participant fails to:
 - A. Meet schedules;
 - B. Pay any required fees or taxes; or
 - C. Otherwise perform in accordance with the specifications.
29. Successful Participant shall defend, indemnify and save harmless County and all its elected officials, officers, agents and employees from all suits, actions, or other claims of any character, name and description brought for or on account of any injuries or damages received or sustained by any person, persons, or property on account of any negligent act or fault of the successful Participant, or of any agent, employee, subcontractor or supplier of successful Participant in the execution of, or performance under, any contract which may result from RFSQ award or which arises from any event or casualty happening on or within County premises themselves or happening upon or in any halls, elevators, entrances, stairways or approaches of or to such County facilities. Successful Participant shall pay any judgment with costs which may be obtained against County growing out of such injury or damages, and shall, upon request, provide a defense to County by counsel reasonably acceptable to County. Successful Participant's indemnity hereunder shall include, but is not limited to, claims relating to patent, copyright or trademark infringement, and the like, arising out of the goods and services provided by successful Participant.
30. Successful Participant shall warrant that all items/services shall conform with the specifications and/or all warranties provided under the Uniform Commercial Code and be free from all defects in material, workmanship and the like. Items supplied under a contract pursuant to this Request for RFSQs shall be subject to County's approval. Items found to be defective or not meeting specifications shall be replaced by successful Participant within two business days at no expense to County. Items not picked up within one (1) week after notification shall be deemed a donation to County and may be used or disposed of at County's discretion and without waiver of any other rights of County as to the item's nonconformity.
31. This document and any disputes arising hereunder shall be governed and construed according to the laws of the State of Texas, and will be performable exclusively in Hidalgo County, Texas.
32. The successful Participant shall not assign, sell, transfer or convey its rights under any awarded contract, in whole or in part, without the prior written consent of County.

RFSQ
for
HIDALGO COUNTY PRECINCT NO. 4
“GARBAGE COLLECTION AT THE NEW SAN CARLOS CRC BLDG”
RFSQ No: 2017-097-03-06-SGS

To: Martha L. Salazar, CPPB, Purchasing Agent
Hidalgo County Purchasing Department
Sandy Suarez, Buyer II
Physical Address: 2802 S. Business Hwy. 281 - Administration Building
Mailing/Postal Address: 2812 S. Business Hwy. 281
Edinburg, Texas 78539

In accordance with the Specifications, and subject to all laws and regulations of the United States and state and local laws, the undersigned Participant proposes and commits to furnish all labor, equipment, material, software and services as set forth in the documents hereinbefore mentioned. The undersigned Participant further agrees, upon acceptance of its RFSQ, to execute a contract and/or Purchase Order issued by Hidalgo County for performing and completing the work described in the Specifications within the time stated and for the prices proposed in the documents attached hereto and made a part hereof.

Participant acknowledges receipt of all of the pages of the documents referenced in the Invitation to RFSQ Checklist presented in connection with this procurement. Participant understands that Hidalgo County reserves the right to reject any or all RFSQs and further reserves the right to design the evaluation criteria to be used in selecting the lowest and best RFSQ.

Participant agrees that this RFSQ shall be good and may not be withdrawn for a period of thirty (30) calendar days after the scheduled closing time for receiving RFSQs, as contained in the Specifications.

Respectfully submitted,

Participant:	
Address:	
By:	
Printed Name:	
Title:	

Must be submitted with the quote

SPECIFICATIONS
EXHIBIT "A"
HIDALGO COUNTY PRECINCT 4
"GARBAGE COLLECTION AT NEW SAN CARLOS CRC"
RFSQ NO.: 2017-097-03-06-SGS

PROJECT OVERVIEW:

Hidalgo County Precinct No. 4, is requesting sealed quotes for the service of "Garbage Collection & disposal" services from certified, licensed Vendors, on an "as needed basis". Vendor will be required to collect; transport and dispose of solid waste (garbage,) **one** (1) day per week, generated by "Hidalgo County Precinct No. 4- San Carlos Community Resource Center", but in no event to exceed the \$50,000.00 (per year) statutory bid limit including, but not limited to the following:

SPECIFICATIONS/REQUIREMENTS:

In accordance with the specifications/requirements specified herein and including, but not limited to all provisions set forth in the accompanying documentation. Any Response that does not meet the minimum requirements and/or specifications may be rejected.

1. Vendor will be required to provide one (1) waste container - four (4) cubic yard solid (front load) - ****slanted top**, with lid.
 - Approximate dimensions of container: 5'6"L x 6' W x 5'H or equal 4 cubic yds.
 - Container will be in a fenced **Holding Area** that is approximately: 10' L x 10' x 12' W. (See Attachment A-1)

****Slant top preferred, but a four (4) cubic yard container, with flat top, will be taken into consideration, must fit in Holding Area. Indicate dimensions, on Exhibit "B".**

2. Participant must provide the name and location of landfill site to which the solid waste will be delivered and disposed of.
3. **If Participant(s) is not the owner or operator of the landfill site, Vendor must provide copies of documents authorizing Vendor to properly dispose of solid waste is such landfill.**
4. Participant shall provide a copy of current permit for the landfill size issued by the Texas Natural Resource Conservation Commission (TNRCC) evidencing authorization for the disposal of solid waste. Awarded Participant must be in compliance throughout the term of contract.
5. The successful Vendor agrees to abide by all applicable state laws, regulations, and be in compliance with all OSHA and TXDOT's regulations and requirements for the transportation of solid waste materials throughout the term of the contract.
6. Awarded Vendor must present evidence that it possesses all federal, state and local permits necessary to properly conduct and operate a waste collection and disposal business.

SPECIFICATIONS
EXHIBIT "A"
HIDALGO COUNTY PRECINCT 4
"GARBAGE COLLECTION AT NEW SAN CARLOS CRC"
RFSQ NO.: 2017-097-03-06-SGS

7. Participant will provide all labor, machinery and equipment, tools and materials required to render services.
8. Participant must indicate on the Quote page (Exhibit "B") of any additional fees.
9. Any spillage of waste at any stage of the collection and transportation shall immediately be cleaned and removed by awarded contractor.
10. Upon award, Vendor shall provide a Schedule of Collection days to the Department, so that they may chose the day most convenient for them. Collection time **shall be** between the hours of **7:00 A.M. and 10:00 A.M.** County personnel will be available to open the premises.

DELAYS

A minimum of **one** (1) delay per month will be acceptable. Awarded Contractor **must** notify Hidalgo County Pct. 4, of any delay(s) with the scheduled pick up time. A Point of Contact and telephone number shall be provided to the awarded Vendor.

LOCATION OF SERVICES:

Hidalgo County Precinct No. 4
San Carlos Community Resource Center
107 North Sunflower
La Blanca, TX. 78558

BILLING STATEMENT:

Awarded Vendor will bill the County on a "monthly basis." The monthly bill and/or statement will be sent to: Hidalgo County Pct. No. 4 Administration Office
1051 N. Doolittle Rd.
Edinburg, TX. 78542
(956) 383-3112

STANDARD TERMS & CONDITION:

1. Contract will commence upon the completion of the San Carlos CRC and upon the

SPECIFICATIONS
EXHIBIT "A"
HIDALGO COUNTY PRECINCT 4
"GARBAGE COLLECTION AT NEW SAN CARLOS CRC"
RFSQ NO.: 2017-097-03-06-SGS

approval of Hidalgo County Commissioner's Court.

2. Term of contract is for a one (1) year period.
3. County reserves the right to continue this bid for an additional sixty (60) day grace period at the end of the contract term for unforeseen delay in award of new bid for next contract term.
4. County reserves the right to award the contract to the responsible participant (s) who submits the lowest and best bid or may reject all bids and issue a new solicitation. If two responsible participants submit the lowest and best; bid will be made to the responsible participant(s) submitting the lowest bid prices for the item(s) as specified.
5. Hidalgo County reserves the right to hold quotes/bids for a period of ninety (90) days without taking any action.
6. County will seek purchases from State awarded vendors whenever it is, its best interest to do so.
7. After bid is awarded and low bidder(s) default(s) in meeting the general instructions to bidders and/or comply with contract agreement, Hidalgo County reserves the right to seek services from the next low bidder. In such event, County shall charge the successful bidder the difference for any additional cost of such item.
8. Any contract awarded to a successful bidder will be in effect until;
 - a) The contract expires
 - b) Delivery acceptance of products and/or performance of services ordered, or
 - c) Terminated by County with thirty (30) days written notice prior to be cancellation.
9. Hidalgo County reserves the right to award the bid to ONE or to MULTIPLE bidders if the County determines it is in its best interest to do so.
10. Hidalgo County reserves the right to add or delete the number of containers and/or increase the size of container, during the term of the contract under the same terms, rates and conditions
11. Have been in business for at least two years.
12. The Participant awarded the contract **shall not engage** the service of a subcontractor

SPECIFICATIONS
EXHIBIT "A"
HIDALGO COUNTY PRECINCT 4
"GARBAGE COLLECTION AT NEW SAN CARLOS CRC"
RFSQ NO.: 2017-097-03-06-SGS

without prior written consent of Hidalgo County. When requesting written consent from Hidalgo County to retain a subcontractor to perform services hereunder the successful bidder must present evidence and submit to the County that the successful bidder and the proposed subcontractor possess all necessary licenses and permits to perform the services described herein and that the successful bidder and the proposed subcontractor have obtained and submitted the required insurance coverage and policies as required by Hidalgo County.

13. Insurance requirements for this project to be maintained throughout the contract term (Refer to limits on the Exhibit "C" for limits).
14. Hidalgo County reserves the right to reject any/all quotes/bids, to waive any/all formalities or technicalities, or to accept the quote/bid considered the best and most advantage to the County.
15. Vendors(s) agrees that to the extent an item(s) and/or service is unavailable from Vendor(s) own inventory, Vendor(s) will be Responsible for locating an alternative supplier and for providing the product and/or service to Hidalgo County at Bidder's expense.
16. **All costs and expenses associated with the preparation and submission of (bids, proposals, statement of qualifications and/or quotes) shall be responsibility of the bidder and no reimbursements for such charges or expenses shall be passed on to HIDALGO COUNTY.**

MARKET VOLATILITY AND UNIT PRICE ADJUSTMENTS:

Hidalgo County recognizes that during periods of national crisis and unstable economic conditions, unforeseen price increases might affect costs for goods and services contracted on an annual basis. The following procedure may be employed to mediate price volatility:

- 1) **Requesting Price Adjustment:** Upon written request of the Vendor to the County Purchasing Agent, the County may review evidence of prevailing industry-wide market conditions that warrant an adjustment in bid prices contained in the contract.
 - A Vendor must tie any price change clause to an industry-wide or otherwise nationally recognized index, or some other form of verifiable document. Such written request must be accompanied by a certified copy of the supplier's advisory or notification to the vendor of the price changes.

SPECIFICATIONS
EXHIBIT "A"
HIDALGO COUNTY PRECINCT 4
"GARBAGE COLLECTION AT NEW SAN CARLOS CRC"
RFSQ NO.: 2017-097-03-06-SGS

- The Vendor must put the Purchasing Agent on the mailing lists for such publications so that the Purchasing Agent can monitor said changes. Such membership shall be at no cost to the County.
 - The County Purchasing Agent retains the right to determine whether or not such proposed price changes are in the best interest of the County.
 - No price escalation will be authorized in excess of the amount of the increase referred to in the supplier's notice.
 - The County may only grant a price increase if the evidence presented is deemed reliable. Should the County allow a price increase, the approved price change shall be honored for all orders received by the vendor or contractor after the effective date of such price change. Approved price changes are not applicable to orders already issued and in process at time of price change.
- 2) **Price Reduction:** Vendor shall notify the County at the time when the Vendor's costs for items and/or supplies reduce due to stabilization in the market at which time prices for items on this contract shall be reduced accordingly. Failure by the Vendor to notify the County of a decrease in costs for items and/or supplies for which the Vendor was granted a price adjustment, may result in immediate termination of this contract and the County shall not be obligated to pay the Vendor the difference between the contract price and the price adjustment.
- 3) **Timeframe for Adjusted Price Increases:** Price increases are only valid for the quarter in which they are requested and approved. Prices shall return to the original contract price at the beginning of the following quarter unless a Vendor notifies the County in writing within ten (10) days of expiration of the quarter in which the price increase is in effect, that it desires to have the price increase continue or that the Vendor is requesting a different price increase for the following quarter. Such request must be supplemented with sufficient justification to demonstrate that the price increase remains necessary. The County Purchasing Department shall have sole discretion whether to grant the price increase extension. The County too, shall have discretion to unilaterally reduce, eliminate or extend a price adjustment to the Vendor at any time upon written notice from the County to the Vendor demonstrating justification for such reduction, elimination or extension of the price adjustment.
- 4) **Allowable Review Periods:** Price adjustment reviews may only be requested by the Vendor on a quarterly basis. However, the County may at its own discretion, conduct temporary price adjustment reviews at any time. The County Purchasing Agent and/or

**SPECIFICATIONS
EXHIBIT "A"
HIDALGO COUNTY PRECINCT 4
"GARBAGE COLLECTION AT NEW SAN CARLOS CRC"
RFSQ NO.: 2017-097-03-06-SGS**

the County Auditor reserve the right to audit and/or examine any pertinent books, documents, papers, records or invoices relating directly to the contract transaction in question after reasonable notice and during normal business hours.

- 5) **Dollar Limit to Price Changes:** The total increase in contract price shall not exceed twenty-five percent (25%) of the original contract price during the contract term.

ADDITIONAL INFORMATION:

Information regarding this project can be addressed in writing, to the Hidalgo County Purchasing Department. Hidalgo County is also requesting that any and all questions, inquiries and clarifications regarding quotes, bids, proposal or statement of qualifications be addressed to Martha L. Salazar, CPPB, Purchasing Agent, **Attention Sandy Suarez: 2802 SOUTH BUSINESS HWY 281, EDINBURG, TEXAS 78539.**

TELEPHONE INQUIRIES WILL NOT BE ACCEPTED.

INQUIRIES & RESPONSES:

All Written Inquiries will be accepted Via Email to sandy.suarez@co.hidalgo.tx.us, No later than, Monday, March 27, 2017 at 5:00 P.M., at (956) 292-7612. Responses to said Inquiries will be sent to all Participants via Email by No Later than 5:00 P.M Tuesday, March 28, 2017.

Hidalgo County Pct 4
"Garbage Collection at New San Carlos CRC"
RFSQ NO.: 2017-097-03-06-SGS

Attachment A-1

Holding Area

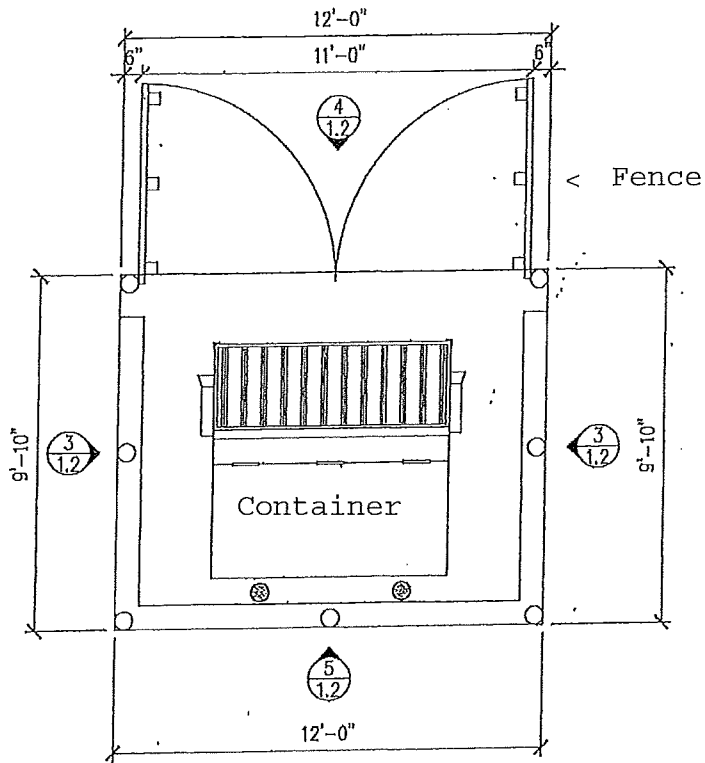

EXHIBIT "B"
HIDALGO COUNTY PRECINCT NO. 4
"GARBAGE COLLECTION AT NEW SAN CARLOS CRC"
RFSQ NO.: 2017-097-03-06-SGS

QUOTE PAGE

PART I

AWARD WILL BE BASED ON THE LOWEST & BEST BID MEETING ALL SPECIFICATIONS / REQUIREMENTS.
Internal Use Only: Commodity Code: 910-27

LOCATION SITE:	
SAN CARLOS COMMUNITY RESOURCE CENTER - HIDALGO COUNTY PRECINCT # 4	
	COST
Charges for <u>One (1) day</u> per Week Collection Service	Total Monthly Cost \$ _____
Additional Charges – (specify below)	\$ _____
Specify Additional Fee: _____	
CONTAINER TO BE PROVIDED BY VENDOR	Container As per Specifications
<u>Slant top-Container</u> - (1) with lid (as per Specs- 5'6"L x 6' W x 5'H or equal 4 cubic yds.	Yes - <input checked="" type="checkbox"/>
	No - <input type="checkbox"/>
<u>Flat top-Container</u> - (1) with lid Indicate Dimensions–(must be 4 cubic yards-fit in Holding Area)	
Copies of Documents authorizing Vendor to dispose of solid waste in Landfill, as per Exhibit A-Specifications - (if applicable)	Enclosed <input checked="" type="checkbox"/>

LANDFILL SITE ADDRESS/LOCATION:

ACKNOWLEDGMENT FORM

PART II

I/We the undersigned hereby certify that I/We am/are a duly authorized official of the company and have the authority to sign on behalf of the company and assure that all statements made in the bid are true. I/We agree to furnish and deliver the specified items/services at the prices stated herein, and have read, understand, and agree to the terms and conditions contained herein and on all of the attachments.

BIDDER/COMPANY NAME: _____

ADDRESS: _____

CITY/STATE/ZIP CODE: _____

PHONE & FAX NUMBER: _____

E-MAIL ADDRESS: _____

CELLULAR NUMBER: _____

AUTHORIZED SIGNATURE: _____

PRINTED NAME: _____

TITLE: _____

DATE: _____

(Must be submitted with Bid Packet)

EXHIBIT “C”
Insurance Requirements
Applicable to the Acquisition of Goods and /or Services
(other than Professional Services)

The Bidder awarded the contract shall furnish proof of insurance, which will also include any subcontractor that is subcontracted by the bidder in at least the following limits, to be in place prior to providing any services under this Contract and to continue at all times in force in effect during the term of this Contract:

1. A Five Hundred Thousand Dollar (\$500,000.00) Comprehensive General Liability insurance policy providing additional coverage to all underlying liabilities of County.
2. Automobile liability insurance policy with limits of at least Three Hundred Thousand Dollars (\$300,000.00) per person and Five Hundred Thousand Dollars (\$500,000.00) per occurrence. Coverage should include injury to or death of persons and property damage claims with limits up to Five Hundred Thousand (\$500,000.00) arising out of the services provided to County hereunder.
3. Uninsured/Underinsured motorist coverage in an amount equal to the bodily injury limits set forth immediately above;
4. Workers compensation insurance in amounts established by Texas law, unless the Bidder is specifically exempted from the Texas Workers Compensation Act, Texas Labor Code Chapter 401, et. seq.

Hidalgo County will only accept certificates of insurance on an Acord form (as attached hereto). Certificates of insurance naming County as an **additional insured** shall be submitted to County for approval prior to any services being performed by Contractor. Each policy of insurance required hereunder shall extend for a period equivalent to, or longer than the term of the Contract, and any insurer hereunder shall be required to give at least thirty (30) days written notice to the County prior to the cancellation of any such coverage on the termination date, or otherwise. This Contract shall be automatically suspended upon the cancellation, or other termination, of any required policy of insurance hereunder, and such suspension shall continue until evidence adequate replacement coverage is provided to County. If replacement coverage is not provided within thirty (30) days following suspension of the Contract, this Contract shall automatically terminate.

ACORD	CERTIFICATE OF INSURANCE	DATE (MM/DD/YY)
PRODUCER	THIS CERTIFICATE IS ISSUED AS A MATTER OF INFORMATION ONLY AND CONFERS NO RIGHTS UPON THE CERTIFICATE HOLDER. THIS CERTIFICATE DOES NOT AMEND, EXTEND OR ALTER THE COVERAGE AFFORDED BY THE POLICIES BELOW.	
	INSURERS AFFORDING COVERAGE	
INSURED	INSURER A:	
	INSURER B:	
	INSURER C:	
	INSURER D:	
	INSURER E:	

COVERAGES

THE POLICIES OF INSURANCE LISTED BELOW HAVE BEEN ISSUED TO THE INSURED NAMED ABOVE FOR THE POLICY PERIOD INDICATED. NOTWITHSTANDING ANY REQUIREMENT, TERM OR CONDITION OF ANY CONTRACT OR OTHER DOCUMENT WITH RESPECT TO WHICH THIS CERTIFICATE MAY BE ISSUED OR MAY PERTAIN, THE INSURANCE AFFORDED BY THE POLICIES DESCRIBED HEREIN IS SUBJECT TO ALL THEIR TERMS, EXCLUSIONS AND CONDITIONS OF SUCH POLICIES. AGGREGATE LIMITS SHOWN MAY HAVE BEEN REDUCED BY PAID CLAIMS.

INSR LTR	TYPE OF INSURANCE	POLICY NUMBER	POLICY EFFECTIVE DATE (MM/DD/YY)	POLICY EXPIRATION DATE (MM/DD/YY)	LIMITS
A	GENERAL LIABILITY				EACH OCCURRENCE \$
	<input type="checkbox"/> COMMERCIAL GENERAL LIABILITY				FIRE DAMAGE (Any one fire) \$
	<input type="checkbox"/> CLAIMS MADE OCCUR				MEDICAL (Any one person) \$
	<input type="checkbox"/> OWNER'S & CONT. PROT				PERSONAL & ADV INJURY \$
	<input type="checkbox"/> OWNER'S PROTECTIVE LIABILITY				GENERAL AGGREGATE \$
	<input type="checkbox"/> GEN L AGGREGATE LIMIT APPLIES PER: POLICY <input type="checkbox"/> PROJECT <input type="checkbox"/> LOC				PRODUCTS - COMP/OP AGG \$
B	AUTOMOBILE LIABILITY				COMBINED SINGLE LIMIT (Ea accident) \$
	<input type="checkbox"/> ANY AUTO				BODILY INJURY (Per person) \$
	<input type="checkbox"/> ALL OWNED AUTOS				BODILY INJURY (Per accident) \$
	<input type="checkbox"/> SCHEDULED AUTOS				PROPERTY DAMAGE (Per accident) \$
	<input type="checkbox"/> HIRED AUTOS <input type="checkbox"/> NON-OWNED AUTOS				
	GARAGE LIABILITY				AUTO ONLY-EA ACCIDENT \$
	<input type="checkbox"/> ANY AUTO				OTHER THAN AUTO ONLY EA ACC AGG \$
C	EXCESS LIABILITY				EACH OCCURRENCE \$
	<input type="checkbox"/> OCCUR <input type="checkbox"/> CLAIMS MADE				AGGREGATE \$
	<input type="checkbox"/> DEDUCTIBLE				\$
	<input type="checkbox"/> RETENTION \$				\$
D	WORKERS COMPENSATION AND EMPLOYER'S LIABILITY				WC STATUTORY LIMITS <input type="checkbox"/> OTHER \$
					E.L. EACH ACCIDENT \$
					E.L. DISEASE-EA EMPLOYEE \$
					E.L. DISEASE-POLICY LIMIT \$
	OTHER				

DESCRIPTION OF OPERATIONS / LOCATION / VEHICLES / EXCLUSIONS ADDED BY ENDORSEMENT / SPECIAL PROVISIONS
 County of Hidalgo shall be named as additional insured on all Commercial General Liability policies.

CERTIFICATE HOLDER	ADDITIONAL INSURED; INSURER LETTER:	CANCELLATION
Hidalgo County Attn: Purchasing Department 2812 S Highway Bus. 281 Edinburg, Texas 78539		SHOULD ANY OF THE ABOVE DESCRIBED POLICIES BY CANCELLED BEFORE THE EXPIRATION DATE THEREOF, THE ISSUING INSURER WILL ENDEAVOR TO MAIL 30 DAYS WRITTEN NOTICE TO THE CERTIFICATE HOLDER NAMED TO THE LEFT, BUT FAILURE TO DO SO SHALL IMPOSE NO OBLIGATION OR LIABILITY OF ANY KIND UPON THE INSURER, ITS AGENTS OR REPRESENTATIVES. AUTHORIZED REPRESENTATIVE

Insurance Requirement Acknowledgment

I, _____, authorized representative for _____,
Company/Vendor

hereby acknowledge receipt of the County's required insurance limits. Said requirements:

- will be acquired within 10 working days after notification from Purchasing Department of bid awarded by the Hidalgo County Commissioners' Court;
- will acquire additional amounts required to meet the County's requirements within 10 working days after notification from Purchasing Department of bid award by the Hidalgo County Commissioners' Court; currently carry the following:

Automobile Liability: \$ _____ General Liability: \$ _____

- have already been met, see attached copy of insurance certificate.

Authorized Representative

Date

Notice to Bidder:

A certificate of insurance for the required insurance limits shall be provided to the Purchasing Department's Contract Managers in order to qualify for award of bid and to execute a contract between your Company and the County

Failure to provide Certificates of Insurance to the Purchasing Department's Contract Managers will cause the bid award to be rescinded and re-awarded to next lowest bidder. Certificates of Insurance will be monitored and verified on a **quarterly basis** to ensure coverage policy is in place. It is the Company's obligation to maintain the appropriate insurance coverage throughout the term of the contract.

THIS FORM MUST ACCOMPANY BID PACKET

**PROJECT REQUIREMENTS
ACKNOWLEDGMENT**

This is to certify that I, _____, possess all of the APPLICABLE:

- 1. Licenses: _____.
- 2. Bond (if applicable) _____.
- 3. Certificates: _____.
- 4. Permits: _____.
- 5. Other: _____.

necessary to carry out the required project. Furthermore, I am providing copies of the required documentation so that, if my company is awarded this bid, I may be eligible to enter into a contract with Hidalgo County and proceed to complete the project in a timely manner.

* Any licenses, bonds (if applicable), certificates, permits, etc. which are required must be presented as part of the bid packet in order to expedite the bid evaluation process.

Authorized Signature

Date

Company

Address

City, State, Zip

THIS FORM MUST ACCOMPANY BID PACKET

CONFLICT OF INTEREST QUESTIONNAIRE
For vendor doing business with local governmental entity

FORM CIQ

This questionnaire reflects changes made to the law by H.B. 23, 84th Leg., Regular Session.

This questionnaire is being filed in accordance with Chapter 176, Local Government Code, by a vendor who has a business relationship as defined by Section 176.001(1-a) with a local governmental entity and the vendor meets requirements under Section 176.006(a).

By law this questionnaire must be filed with the records administrator of the local governmental entity not later than the 7th business day after the date the vendor becomes aware of facts that require the statement to be filed. See Section 176.006(a-1), Local Government Code.

A vendor commits an offense if the vendor knowingly violates Section 176.006, Local Government Code. An offense under this section is a misdemeanor.

OFFICE USE ONLY
Date Received

1 Name of vendor who has a business relationship with local governmental entity.

2 Check this box if you are filing an update to a previously filed questionnaire. (The law requires that you file an updated completed questionnaire with the appropriate filing authority not later than the 7th business day after the date on which you became aware that the originally filed questionnaire was incomplete or inaccurate.)

3 Name of local government officer about whom the information is being disclosed.

Name of Officer

4 Describe each employment or other business relationship with the local government officer, or a family member of the officer, as described by Section 176.003(a)(2)(A). Also describe any family relationship with the local government officer. Complete subparts A and B for each employment or business relationship described. Attach additional pages to this Form CIQ as necessary.

A. Is the local government officer or a family member of the officer receiving or likely to receive taxable income, other than investment income, from the vendor?

Yes No

B. Is the vendor receiving or likely to receive taxable income, other than investment income, from or at the direction of the local government officer or a family member of the officer AND the taxable income is not received from the local governmental entity?

Yes No

5 Describe each employment or business relationship that the vendor named in Section 1 maintains with a corporation or other business entity with respect to which the local government officer serves as an officer or director, or holds an ownership interest of one percent or more.

6 Check this box if the vendor has given the local government officer or a family member of the officer one or more gifts as described in Section 176.003(a)(2)(B), excluding gifts described in Section 176.003(a-1).

7

Signature of vendor doing business with the governmental entity

Date

CONFLICT OF INTEREST QUESTIONNAIRE

For vendor doing business with local governmental entity

A complete copy of Chapter 176 of the Local Government Code may be found at <http://www.statutes.legis.state.tx.us/Docs/LG/htm/LG.176.htm>. For easy reference, below are some of the sections cited on this form.

Local Government Code § 176.001(1-a): "Business relationship" means a connection between two or more parties based on commercial activity of one of the parties. The term does not include a connection based on:

- (A) a transaction that is subject to rate or fee regulation by a federal, state, or local governmental entity or an agency of a federal, state, or local governmental entity;
- (B) a transaction conducted at a price and subject to terms available to the public; or
- (C) a purchase or lease of goods or services from a person that is chartered by a state or federal agency and that is subject to regular examination by, and reporting to, that agency.

Local Government Code § 176.003(a)(2)(A) and (B):

(a) A local government officer shall file a conflicts disclosure statement with respect to a vendor if:

(2) the vendor:

- (A) has an employment or other business relationship with the local government officer or a family member of the officer that results in the officer or family member receiving taxable income, other than investment income, that exceeds \$2,500 during the 12-month period preceding the date that the officer becomes aware that
 - (i) a contract between the local governmental entity and vendor has been executed;
 - or
 - (ii) the local governmental entity is considering entering into a contract with the vendor;
- (B) has given to the local government officer or a family member of the officer one or more gifts that have an aggregate value of more than \$100 in the 12-month period preceding the date the officer becomes aware that:
 - (i) a contract between the local governmental entity and vendor has been executed; or
 - (ii) the local governmental entity is considering entering into a contract with the vendor.

Local Government Code § 176.006(a) and (a-1)

(a) A vendor shall file a completed conflict of interest questionnaire if the vendor has a business relationship with a local governmental entity and:

- (1) has an employment or other business relationship with a local government officer of that local governmental entity, or a family member of the officer, described by Section 176.003(a)(2)(A);
- (2) has given a local government officer of that local governmental entity, or a family member of the officer, one or more gifts with the aggregate value specified by Section 176.003(a)(2)(B), excluding any gift described by Section 176.003(a-1); or
- (3) has a family relationship with a local government officer of that local governmental entity.

(a-1) The completed conflict of interest questionnaire must be filed with the appropriate records administrator not later than the seventh business day after the later of:

(1) the date that the vendor:

- (A) begins discussions or negotiations to enter into a contract with the local governmental entity; or
- (B) submits to the local governmental entity an application, response to a request for proposals or bids, correspondence, or another writing related to a potential contract with the local governmental entity; or

(2) the date the vendor becomes aware:

- (A) of an employment or other business relationship with a local government officer, or a family member of the officer, described by Subsection (a);
- (B) that the vendor has given one or more gifts described by Subsection (a); or
- (C) of a family relationship with a local government officer.

HISTORICALLY UNDERUTILIZED BUSINESS (HUB) DECLARATION

The primary objective of the Hidalgo County HUB Program is to ensure Historically Underutilized Businesses receive a fair and equal opportunity for participation in the County's procurement process. This fact holds true for Services (Professional & Non-Professional), Commodities, and Construction contracts and any subcontracts thereto. The program strongly encourages Prime Contractors to provide subcontracting opportunities to Certified Hub Contractors/Vendors. Our goal for HUB contractor/vendor participation, as well as HUB subcontractor participation is 30%. To be considered as a "Certified HUB Contractor/Vendor" the contractor/vendor must have been certified by, and hold a current and valid certification with any of the three agencies listed below.

Have you been Certified as a HUB or an MBE/WBE source?: Yes No

If yes, by whom?: Texas Building & Procurement Commission Other _____

Indicate Certification No(s): _____ or Are Certificate(s) Attached?: Yes No

LIST OF CERTIFIED HUB SUBCONTRACTORS
(Attach additional pages if necessary)

What percentage of the Bid, RFP, or RFQ is to be subcontracted with Certified HUB sources?: _____ %
(List HUB Subcontractor information below).

HUB Subcontractor Name: _____ HUB Status:
Certifying Agency (Check all applicable): Texas Building & Procurement Commission Other
Address: _____ City: _____ State: _____ Zip:
Contact Person: _____ Title: _____ Phone No.: ()
Subcontract Amount: \$ _____ Description of Work to be Performed:

HUB Subcontractor Name: _____ HUB Status:
Certifying Agency (Check all applicable): Texas Building & Procurement Commission Other
Address: _____ City: _____ State: _____ Zip:
Contact Person: _____ Title: _____ Phone No.: ()
Subcontract Amount: \$ _____ Description of Work to be Performed:

HUB Subcontractor Name: _____ HUB Status:
Certifying Agency (Check all applicable): Texas Building & Procurement Commission Other
Address: _____ City: _____ State: _____ Zip:
Contact Person: _____ Title: _____ Phone No.: ()
Subcontract Amount: \$ _____ Description of Work to be Performed:

Request for Taxpayer Identification Number and Certification

**Give Form to the
 requester. Do not
 send to the IRS.**

Print or type See Specific Instructions on page 2.	1 Name (as shown on your income tax return). Name is required on this line; do not leave this line blank.	
	2 Business name/disregarded entity name, if different from above	
	3 Check appropriate box for federal tax classification; check only one of the following seven boxes: <input type="checkbox"/> Individual/sole proprietor or single-member LLC <input type="checkbox"/> C Corporation <input type="checkbox"/> S Corporation <input type="checkbox"/> Partnership <input type="checkbox"/> Trust/estate <input type="checkbox"/> Limited liability company. Enter the tax classification (C=C corporation, S=S corporation, P=partnership) ▶ _____ Note. For a single-member LLC that is disregarded, do not check LLC; check the appropriate box in the line above for the tax classification of the single-member owner. <input type="checkbox"/> Other (see instructions) ▶ _____	4 Exemptions (codes apply only to certain entities, not individuals; see instructions on page 3): Exempt payee code (if any) _____ Exemption from FATCA reporting code (if any) _____ <i>(Applies to accounts maintained outside the U.S.)</i>
	5 Address (number, street, and apt. or suite no.)	Requester's name and address (optional)
	6 City, state, and ZIP code	
	7 List account number(s) here (optional)	

Part I Taxpayer Identification Number (TIN)

Enter your TIN in the appropriate box. The TIN provided must match the name given on line 1 to avoid backup withholding. For individuals, this is generally your social security number (SSN). However, for a resident alien, sole proprietor, or disregarded entity, see the Part I Instructions on page 3. For other entities, it is your employer identification number (EIN). If you do not have a number, see *How to get a TIN* on page 3.

Note. If the account is in more than one name, see the instructions for line 1 and the chart on page 4 for guidelines on whose number to enter.

Social security number								
<table style="width: 100%; border-collapse: collapse;"> <tr> <td style="width: 25%; border: 1px solid black;"> </td> <td style="width: 25%; border: 1px solid black;"> </td> <td style="width: 25%; border: 1px solid black;"> </td> <td style="width: 25%; border: 1px solid black;"> </td> </tr> <tr> <td style="text-align: center;">-</td> <td style="text-align: center;">-</td> <td style="text-align: center;">-</td> <td style="text-align: center;">-</td> </tr> </table>					-	-	-	-
-	-	-	-					
or								
Employer identification number								
<table style="width: 100%; border-collapse: collapse;"> <tr> <td style="width: 25%; border: 1px solid black;"> </td> <td style="width: 25%; border: 1px solid black;"> </td> <td style="width: 25%; border: 1px solid black;"> </td> <td style="width: 25%; border: 1px solid black;"> </td> </tr> <tr> <td style="text-align: center;">-</td> <td style="text-align: center;">-</td> <td style="text-align: center;">-</td> <td style="text-align: center;">-</td> </tr> </table>					-	-	-	-
-	-	-	-					

Part II Certification

Under penalties of perjury, I certify that:

1. The number shown on this form is my correct taxpayer identification number (or I am waiting for a number to be issued to me); and
2. I am not subject to backup withholding because: (a) I am exempt from backup withholding, or (b) I have not been notified by the Internal Revenue Service (IRS) that I am subject to backup withholding as a result of a failure to report all interest or dividends, or (c) the IRS has notified me that I am no longer subject to backup withholding; and
3. I am a U.S. citizen or other U.S. person (defined below); and
4. The FATCA code(s) entered on this form (if any) indicating that I am exempt from FATCA reporting is correct.

Certification instructions. You must cross out item 2 above if you have been notified by the IRS that you are currently subject to backup withholding because you have failed to report all interest and dividends on your tax return. For real estate transactions, item 2 does not apply. For mortgage interest paid, acquisition or abandonment of secured property, cancellation of debt, contributions to an individual retirement arrangement (IRA), and generally, payments other than interest and dividends, you are not required to sign the certification, but you must provide your correct TIN. See the instructions on page 3.

Sign Here	Signature of U.S. person ▶	Date ▶
------------------	----------------------------	--------

General Instructions

Section references are to the Internal Revenue Code unless otherwise noted.

Future developments. Information about developments affecting Form W-9 (such as legislation enacted after we release it) is at www.irs.gov/fw9.

Purpose of Form

An individual or entity (Form W-9 requester) who is required to file an information return with the IRS must obtain your correct taxpayer identification number (TIN) which may be your social security number (SSN), individual taxpayer identification number (ITIN), adoption taxpayer identification number (ATIN), or employer identification number (EIN), to report on an information return the amount paid to you, or other amount reportable on an information return. Examples of information returns include, but are not limited to, the following:

- Form 1099-INT (interest earned or paid)
- Form 1099-DIV (dividends, including those from stocks or mutual funds)
- Form 1099-MISC (various types of income, prizes, awards, or gross proceeds)
- Form 1099-B (stock or mutual fund sales and certain other transactions by brokers)
- Form 1099-S (proceeds from real estate transactions)
- Form 1099-K (merchant card and third party network transactions)

- Form 1098 (home mortgage interest), 1098-E (student loan interest), 1098-T (tuition)
- Form 1099-C (canceled debt)
- Form 1099-A (acquisition or abandonment of secured property)

Use Form W-9 only if you are a U.S. person (including a resident alien), to provide your correct TIN.

If you do not return Form W-9 to the requester with a TIN, you might be subject to backup withholding. See What Is Backup Withholding? on page 2.

By signing the filled-out form, you:

1. Certify that the TIN you are giving is correct (or you are waiting for a number to be issued),
2. Certify that you are not subject to backup withholding, or
3. Claim exemption from backup withholding if you are a U.S. exempt payee. If applicable, you are also certifying that as a U.S. person, your allocable share of any partnership income from a U.S. trade or business is not subject to the withholding tax on foreign partners' share of effectively connected income, and
4. Certify that FATCA code(s) entered on this form (if any) indicating that you are exempt from the FATCA reporting, is correct. See *What Is FATCA Reporting?* on page 2 for further information.

Note. If you are a U.S. person and a requester gives you a form other than Form W-9 to request your TIN, you must use the requester's form if it is substantially similar to this Form W-9.

Definition of a U.S. person. For federal tax purposes, you are considered a U.S. person if you are:

- An individual who is a U.S. citizen or U.S. resident alien;
- A partnership, corporation, company, or association created or organized in the United States or under the laws of the United States;
- An estate (other than a foreign estate); or
- A domestic trust (as defined in Regulations section 301.7701-7).

Special rules for partnerships. Partnerships that conduct a trade or business in the United States are generally required to pay a withholding tax under section 1446 on any foreign partners' share of effectively connected taxable income from such business. Further, in certain cases where a Form W-9 has not been received, the rules under section 1446 require a partnership to presume that a partner is a foreign person, and pay the section 1446 withholding tax. Therefore, if you are a U.S. person that is a partner in a partnership conducting a trade or business in the United States, provide Form W-9 to the partnership to establish your U.S. status and avoid section 1446 withholding on your share of partnership income.

In the cases below, the following person must give Form W-9 to the partnership for purposes of establishing its U.S. status and avoiding withholding on its allocable share of net income from the partnership conducting a trade or business in the United States:

- In the case of a disregarded entity with a U.S. owner, the U.S. owner of the disregarded entity and not the entity;
- In the case of a grantor trust with a U.S. grantor or other U.S. owner, generally, the U.S. grantor or other U.S. owner of the grantor trust and not the trust; and
- In the case of a U.S. trust (other than a grantor trust), the U.S. trust (other than a grantor trust) and not the beneficiaries of the trust.

Foreign person. If you are a foreign person or the U.S. branch of a foreign bank that has elected to be treated as a U.S. person, do not use Form W-9. Instead, use the appropriate Form W-8 or Form 8233 (see Publication 515, Withholding of Tax on Nonresident Aliens and Foreign Entities).

Nonresident alien who becomes a resident alien. Generally, only a nonresident alien individual may use the terms of a tax treaty to reduce or eliminate U.S. tax on certain types of income. However, most tax treaties contain a provision known as a "saving clause." Exceptions specified in the saving clause may permit an exemption from tax to continue for certain types of income even after the payee has otherwise become a U.S. resident alien for tax purposes.

If you are a U.S. resident alien who is relying on an exception contained in the saving clause of a tax treaty to claim an exemption from U.S. tax on certain types of income, you must attach a statement to Form W-9 that specifies the following five items:

1. The treaty country. Generally, this must be the same treaty under which you claimed exemption from tax as a nonresident alien.
2. The treaty article addressing the income.
3. The article number (or location) in the tax treaty that contains the saving clause and its exceptions.
4. The type and amount of income that qualifies for the exemption from tax.
5. Sufficient facts to justify the exemption from tax under the terms of the treaty article.

Example. Article 20 of the U.S.-China income tax treaty allows an exemption from tax for scholarship income received by a Chinese student temporarily present in the United States. Under U.S. law, this student will become a resident alien for tax purposes if his or her stay in the United States exceeds 5 calendar years. However, paragraph 2 of the first Protocol to the U.S.-China treaty (dated April 30, 1984) allows the provisions of Article 20 to continue to apply even after the Chinese student becomes a resident alien of the United States. A Chinese student who qualifies for this exception (under paragraph 2 of the first protocol) and is relying on this exception to claim an exemption from tax on his or her scholarship or fellowship income would attach to Form W-9 a statement that includes the information described above to support that exemption.

If you are a nonresident alien or a foreign entity, give the requester the appropriate completed Form W-8 or Form 8233.

Backup Withholding

What is backup withholding? Persons making certain payments to you must under certain conditions withhold and pay to the IRS 28% of such payments. This is called "backup withholding." Payments that may be subject to backup withholding include interest, tax-exempt interest, dividends, broker and barter exchange transactions, rents, royalties, nonemployee pay, payments made in settlement of payment card and third party network transactions, and certain payments from fishing boat operators. Real estate transactions are not subject to backup withholding.

You will not be subject to backup withholding on payments you receive if you give the requester your correct TIN, make the proper certifications, and report all your taxable interest and dividends on your tax return.

Payments you receive will be subject to backup withholding if:

1. You do not furnish your TIN to the requester,
2. You do not certify your TIN when required (see the Part II Instructions on page 3 for details),

3. The IRS tells the requester that you furnished an incorrect TIN,

4. The IRS tells you that you are subject to backup withholding because you did not report all your interest and dividends on your tax return (for reportable interest and dividends only), or

5. You do not certify to the requester that you are not subject to backup withholding under 4 above (for reportable interest and dividend accounts opened after 1983 only).

Certain payees and payments are exempt from backup withholding. See *Exempt payee code* on page 3 and the separate Instructions for the Requester of Form W-9 for more information.

Also see *Special rules for partnerships* above.

What is FATCA reporting?

The Foreign Account Tax Compliance Act (FATCA) requires a participating foreign financial institution to report all United States account holders that are specified United States persons. Certain payees are exempt from FATCA reporting. See *Exemption from FATCA reporting code* on page 3 and the Instructions for the Requester of Form W-9 for more information.

Updating Your Information

You must provide updated information to any person to whom you claimed to be an exempt payee if you are no longer an exempt payee and anticipate receiving reportable payments in the future from this person. For example, you may need to provide updated information if you are a C corporation that elects to be an S corporation, or if you no longer are tax exempt. In addition, you must furnish a new Form W-9 if the name or TIN changes for the account; for example, if the grantor of a grantor trust dies.

Penalties

Failure to furnish TIN. If you fail to furnish your correct TIN to a requester, you are subject to a penalty of \$50 for each such failure unless your failure is due to reasonable cause and not to willful neglect.

Civil penalty for false information with respect to withholding. If you make a false statement with no reasonable basis that results in no backup withholding, you are subject to a \$500 penalty.

Criminal penalty for falsifying information. Willfully falsifying certifications or affirmations may subject you to criminal penalties including fines and/or imprisonment.

Misuse of TINs. If the requester discloses or uses TINs in violation of federal law, the requester may be subject to civil and criminal penalties.

Specific Instructions

Line 1

You must enter one of the following on this line; do not leave this line blank. The name should match the name on your tax return.

If this Form W-9 is for a joint account, list first, and then circle, the name of the person or entity whose number you entered in Part I of Form W-9.

a. **Individual.** Generally, enter the name shown on your tax return. If you have changed your last name without informing the Social Security Administration (SSA) of the name change, enter your first name, the last name as shown on your social security card, and your new last name.

Note. ITIN applicant: Enter your individual name as it was entered on your Form W-7 application, line 1a. This should also be the same as the name you entered on the Form 1040/1040A/1040EZ you filed with your application.

b. **Sole proprietor or single-member LLC.** Enter your individual name as shown on your 1040/1040A/1040EZ on line 1. You may enter your business, trade, or "doing business as" (DBA) name on line 2.

c. **Partnership, LLC that is not a single-member LLC, C Corporation, or S Corporation.** Enter the entity's name as shown on the entity's tax return on line 1 and any business, trade, or DBA name on line 2.

d. **Other entities.** Enter your name as shown on required U.S. federal tax documents on line 1. This name should match the name shown on the charter or other legal document creating the entity. You may enter any business, trade, or DBA name on line 2.

e. **Disregarded entity.** For U.S. federal tax purposes, an entity that is disregarded as an entity separate from its owner is treated as a "disregarded entity." See Regulations section 301.7701-2(c)(2)(iii). Enter the owner's name on line 1. The name of the entity entered on line 1 should never be a disregarded entity. The name on line 1 should be the name shown on the income tax return on which the income should be reported. For example, if a foreign LLC that is treated as a disregarded entity for U.S. federal tax purposes has a single owner that is a U.S. person, the U.S. owner's name is required to be provided on line 1. If the direct owner of the entity is also a disregarded entity, enter the first owner that is not disregarded for federal tax purposes. Enter the disregarded entity's name on line 2, "Business name/disregarded entity name." If the owner of the disregarded entity is a foreign person, the owner must complete an appropriate Form W-8 instead of a Form W-9. This is the case even if the foreign person has a U.S. TIN.

Line 2

If you have a business name, trade name, DBA name, or disregarded entity name, you may enter it on line 2.

Line 3

Check the appropriate box in line 3 for the U.S. federal tax classification of the person whose name is entered on line 1. Check only one box in line 3.

Limited Liability Company (LLC). If the name on line 1 is an LLC treated as a partnership for U.S. federal tax purposes, check the "Limited Liability Company" box and enter "P" in the space provided. If the LLC has filed Form 8832 or 2553 to be taxed as a corporation, check the "Limited Liability Company" box and in the space provided enter "C" for C corporation or "S" for S corporation. If it is a single-member LLC that is a disregarded entity, do not check the "Limited Liability Company" box; instead check the first box in line 3 "Individual/sole proprietor or single-member LLC."

Line 4, Exemptions

If you are exempt from backup withholding and/or FATCA reporting, enter in the appropriate space in line 4 any code(s) that may apply to you.

Exempt payee code.

- Generally, individuals (including sole proprietors) are not exempt from backup withholding.
- Except as provided below, corporations are exempt from backup withholding for certain payments, including interest and dividends.
- Corporations are not exempt from backup withholding for payments made in settlement of payment card or third party network transactions.
- Corporations are not exempt from backup withholding with respect to attorneys' fees or gross proceeds paid to attorneys, and corporations that provide medical or health care services are not exempt with respect to payments reportable on Form 1099-MISC.

The following codes identify payees that are exempt from backup withholding. Enter the appropriate code in the space in line 4.

- 1—An organization exempt from tax under section 501(a), any IRA, or a custodial account under section 403(b)(7) if the account satisfies the requirements of section 401(f)(2)
- 2—The United States or any of its agencies or instrumentalities
- 3—A state, the District of Columbia, a U.S. commonwealth or possession, or any of their political subdivisions or instrumentalities
- 4—A foreign government or any of its political subdivisions, agencies, or instrumentalities
- 5—A corporation
- 6—A dealer in securities or commodities required to register in the United States, the District of Columbia, or a U.S. commonwealth or possession
- 7—A futures commission merchant registered with the Commodity Futures Trading Commission
- 8—A real estate investment trust
- 9—An entity registered at all times during the tax year under the investment Company Act of 1940
- 10—A common trust fund operated by a bank under section 584(a)
- 11—A financial institution
- 12—A middleman known in the investment community as a nominee or custodian
- 13—A trust exempt from tax under section 664 or described in section 4947

The following chart shows types of payments that may be exempt from backup withholding. The chart applies to the exempt payees listed above, 1 through 13.

IF the payment is for . . .	THEN the payment is exempt for . . .
Interest and dividend payments	All exempt payees except for 7
Broker transactions	Exempt payees 1 through 4 and 6 through 11 and all C corporations. S corporations must not enter an exempt payee code because they are exempt only for sales of noncovered securities acquired prior to 2012.
Barter exchange transactions and patronage dividends	Exempt payees 1 through 4
Payments over \$600 required to be reported and direct sales over \$5,000 ¹	Generally, exempt payees 1 through 5 ²
Payments made in settlement of payment card or third party network transactions	Exempt payees 1 through 4

¹ See Form 1099-MISC, Miscellaneous Income, and its instructions.

² However, the following payments made to a corporation and reportable on Form 1099-MISC are not exempt from backup withholding: medical and health care payments, attorneys' fees, gross proceeds paid to an attorney reportable under section 6045(f), and payments for services paid by a federal executive agency.

Exemption from FATCA reporting code. The following codes identify payees that are exempt from reporting under FATCA. These codes apply to persons submitting this form for accounts maintained outside of the United States by certain foreign financial institutions. Therefore, if you are only submitting this form for an account you hold in the United States, you may leave this field blank. Consult with the person requesting this form if you are uncertain if the financial institution is subject to these requirements. A requester may indicate that a code is not required by providing you with a Form W-9 with "Not Applicable" (or any similar indication) written or printed on the line for a FATCA exemption code.

- A—An organization exempt from tax under section 501(a) or any individual retirement plan as defined in section 7701(a)(37)
- B—The United States or any of its agencies or instrumentalities
- C—A state, the District of Columbia, a U.S. commonwealth or possession, or any of their political subdivisions or instrumentalities
- D—A corporation the stock of which is regularly traded on one or more established securities markets, as described in Regulations section 1.1472-1(c)(1)(i)
- E—A corporation that is a member of the same expanded affiliated group as a corporation described in Regulations section 1.1472-1(c)(1)(i)
- F—A dealer in securities, commodities, or derivative financial instruments (including notional principal contracts, futures, forwards, and options) that is registered as such under the laws of the United States or any state
- G—A real estate investment trust
- H—A regulated investment company as defined in section 851 or an entity registered at all times during the tax year under the Investment Company Act of 1940
- I—A common trust fund as defined in section 584(a)
- J—A bank as defined in section 581
- K—A broker
- L—A trust exempt from tax under section 664 or described in section 4947(a)(1)
- M—A tax exempt trust under a section 403(b) plan or section 457(g) plan

Note. You may wish to consult with the financial institution requesting this form to determine whether the FATCA code and/or exempt payee code should be completed.

Line 5

Enter your address (number, street, and apartment or suite number). This is where the requester of this Form W-9 will mail your information returns.

Line 6

Enter your city, state, and ZIP code.

Part I. Taxpayer Identification Number (TIN)

Enter your TIN in the appropriate box. If you are a resident alien and you do not have and are not eligible to get an SSN, your TIN is your IRS individual taxpayer identification number (ITIN). Enter it in the social security number box. If you do not have an ITIN, see *How to get a TIN* below.

If you are a sole proprietor and you have an EIN, you may enter either your SSN or EIN. However, the IRS prefers that you use your SSN.

If you are a single-member LLC that is disregarded as an entity separate from its owner (see *Limited Liability Company (LLC)* on this page), enter the owner's SSN (or EIN, if the owner has one). Do not enter the disregarded entity's EIN. If the LLC is classified as a corporation or partnership, enter the entity's EIN.

Note. See the chart on page 4 for further clarification of name and TIN combinations.

How to get a TIN. If you do not have a TIN, apply for one immediately. To apply for an SSN, get Form SS-5, Application for a Social Security Card, from your local SSA office or get this form online at www.ssa.gov. You may also get this form by calling 1-800-772-1213. Use Form W-7, Application for IRS Individual Taxpayer Identification Number, to apply for an ITIN, or Form SS-4, Application for Employer Identification Number, to apply for an EIN. You can apply for an EIN online by accessing the IRS website at www.irs.gov/businesses and clicking on Employer Identification Number (EIN) under Starting a Business. You can get Forms W-7 and SS-4 from the IRS by visiting IRS.gov or by calling 1-800-TAX-FORM (1-800-829-3676).

If you are asked to complete Form W-9 but do not have a TIN, apply for a TIN and write "Applied For" in the space for the TIN, sign and date the form, and give it to the requester. For interest and dividend payments, and certain payments made with respect to readily tradable instruments, generally you will have 60 days to get a TIN and give it to the requester before you are subject to backup withholding on payments. The 60-day rule does not apply to other types of payments. You will be subject to backup withholding on all such payments until you provide your TIN to the requester.

Note. Entering "Applied For" means that you have already applied for a TIN or that you intend to apply for one soon.

Caution: A disregarded U.S. entity that has a foreign owner must use the appropriate Form W-8.

Part II. Certification

To establish to the withholding agent that you are a U.S. person, or resident alien, sign Form W-9. You may be requested to sign by the withholding agent even if items 1, 4, or 5 below indicate otherwise.

For a joint account, only the person whose TIN is shown in Part I should sign (when required). In the case of a disregarded entity, the person identified on line 1 must sign. Exempt payees, see *Exempt payee code* earlier.

Signature requirements. Complete the certification as indicated in items 1 through 5 below.

1. **Interest, dividend, and barter exchange accounts opened before 1984 and broker accounts considered active during 1983.** You must give your correct TIN, but you do not have to sign the certification.
2. **Interest, dividend, broker, and barter exchange accounts opened after 1983 and broker accounts considered inactive during 1983.** You must sign the certification or backup withholding will apply. If you are subject to backup withholding and you are merely providing your correct TIN to the requester, you must cross out item 2 in the certification before signing the form.
3. **Real estate transactions.** You must sign the certification. You may cross out item 2 of the certification.
4. **Other payments.** You must give your correct TIN, but you do not have to sign the certification unless you have been notified that you have previously given an incorrect TIN. "Other payments" include payments made in the course of the requester's trade or business for rents, royalties, goods (other than bills for merchandise), medical and health care services (including payments to corporations), payments to a nonemployee for services, payments made in settlement of payment card and third party network transactions, payments to certain fishing boat crew members and fishermen, and gross proceeds paid to attorneys (including payments to corporations).
5. **Mortgage interest paid by you, acquisition or abandonment of secured property, cancellation of debt, qualified tuition program payments (under section 529), IRA, Coverdell ESA, Archer MSA or HSA contributions or distributions, and pension distributions.** You must give your correct TIN, but you do not have to sign the certification.

³ You must show your individual name and you may also enter your business or DBA name on the "Business name/disregarded entity" name line. You may use either your SSN or EIN (if you have one), but the IRS encourages you to use your SSN.

⁴ List first and circle the name of the trust, estate, or pension trust. (Do not furnish the TIN of the personal representative or trustee unless the legal entity itself is not designated in the account title.) Also see *Special rules for partnerships* on page 2.

*Note. Grantor also must provide a Form W-9 to trustee of trust.

Note. If no name is circled when more than one name is listed, the number will be considered to be that of the first name listed.

Secure Your Tax Records from Identity Theft

Identity theft occurs when someone uses your personal information such as your name, SSN, or other identifying information, without your permission, to commit fraud or other crimes. An identity thief may use your SSN to get a job or may file a tax return using your SSN to receive a refund.

To reduce your risk:

- Protect your SSN,
- Ensure your employer is protecting your SSN, and
- Be careful when choosing a tax preparer.

If your tax records are affected by identity theft and you receive a notice from the IRS, respond right away to the name and phone number printed on the IRS notice or letter.

If your tax records are not currently affected by identity theft but you think you are at risk due to a lost or stolen purse or wallet, questionable credit card activity or credit report, contact the IRS Identity Theft Hotline at 1-800-908-4490 or submit Form 14039.

For more information, see Publication 4535, Identity Theft Prevention and Victim Assistance.

Victims of identity theft who are experiencing economic harm or a system problem, or are seeking help in resolving tax problems that have not been resolved through normal channels, may be eligible for Taxpayer Advocate Service (TAS) assistance. You can reach TAS by calling the TAS toll-free case intake line at 1-877-777-4778 or TTY/TDD 1-800-829-4059.

Protect yourself from suspicious emails or phishing schemes. Phishing is the creation and use of email and websites designed to mimic legitimate business emails and websites. The most common act is sending an email to a user falsely claiming to be an established legitimate enterprise in an attempt to scam the user into surrendering private information that will be used for identity theft.

The IRS does not initiate contacts with taxpayers via emails. Also, the IRS does not request personal detailed information through email or ask taxpayers for the PIN numbers, passwords, or similar secret access information for their credit card, bank, or other financial accounts.

If you receive an unsolicited email claiming to be from the IRS, forward this message to phishing@irs.gov. You may also report misuse of the IRS name, logo, or other IRS property to the Treasury Inspector General for Tax Administration (TIGTA) at 1-800-366-4484. You can forward suspicious emails to the Federal Trade Commission at: spam@uce.gov or contact them at www.ftc.gov/idtheft or 1-877-IDTHEFT (1-877-438-4338).

Visit IRS.gov to learn more about identity theft and how to reduce your risk.

What Name and Number To Give the Requester

For this type of account:	Give name and SSN of:
1. Individual	The individual
2. Two or more individuals (joint account)	The actual owner of the account or, if combined funds, the first individual on the account ¹
3. Custodian account of a minor (Uniform Gift to Minors Act)	The minor ²
4. a. The usual revocable savings trust (grantor is also trustee) b. So-called trust account that is not a legal or valid trust under state law	The grantor-trustee ¹ The actual owner ¹
5. Sole proprietorship or disregarded entity owned by an individual	The owner ³
6. Grantor trust filing under Optional Form 1099 Filing Method 1 (see Regulations section 1.671-4(b)(2)(i)(A))	The grantor*
For this type of account:	Give name and EIN of:
7. Disregarded entity not owned by an individual	The owner
8. A valid trust, estate, or pension trust	Legal entity ⁴
9. Corporation or LLC electing corporate status on Form 8832 or Form 2553	The corporation
10. Association, club, religious, charitable, educational, or other tax-exempt organization	The organization
11. Partnership or multi-member LLC	The partnership
12. A broker or registered nominee	The broker or nominee
13. Account with the Department of Agriculture in the name of a public entity (such as a state or local government, school district, or prison) that receives agricultural program payments	The public entity
14. Grantor trust filing under the Form 1041 Filing Method or the Optional Form 1099 Filing Method 2 (see Regulations section 1.671-4(b)(2)(i)(B))	The trust

¹ List first and circle the name of the person whose number you furnish. If only one person on a joint account has an SSN, that person's number must be furnished.

² Circle the minor's name and furnish the minor's SSN.

Privacy Act Notice

Section 6109 of the Internal Revenue Code requires you to provide your correct TIN to persons (including federal agencies) who are required to file information returns with the IRS to report interest, dividends, or certain other income paid to you; mortgage interest you paid; the acquisition or abandonment of secured property; the cancellation of debt; or contributions you made to an IRA, Archer MSA, or HSA. The person collecting this form uses the information on the form to file information returns with the IRS, reporting the above information. Routine uses of this information include giving it to the Department of Justice for civil and criminal litigation and to cities, states, the District of Columbia, and U.S. commonwealths and possessions for use in administering their laws. The information also may be disclosed to other countries under a treaty, to federal and state agencies to enforce civil and criminal laws, or to federal law enforcement and intelligence agencies to combat terrorism. You must provide your TIN whether or not you are required to file a tax return. Under section 3406, payers must generally withhold a percentage of taxable interest, dividend, and certain other payments to a payee who does not give a TIN to the payer. Certain penalties may also apply for providing false or fraudulent information.

**Certification
Regarding Debarment, Suspension and Ineligibility**

As is required by the Federal Regulations Implementing Executive Order 12549, Debarment and Suspension, 45 CFR Part 76, Government-wide Debarment and Suspension, the applicant certifies, to the best of his or her knowledge and belief, that both it and its principals:

- a. Are not presently debarred, suspended, proposed for debarment, declared ineligible, or voluntarily excluded from participation in this transaction by any federal department or agency;
- b. Have not within a three-year period preceding this bid proposal and/or application been convicted of or had a civil judgment rendered against them for commission of fraud or a criminal offense in connection with obtaining, attempting to obtain, or performing a public (federal, state, or local) transaction or contract under a public transaction, violation of federal or state antitrust statutes or commission of embezzlement, theft, forgery, bribery, falsification or destruction of records, making false statements, or receiving stolen property;
- c. Are not presently indicted for or otherwise criminally or civilly charged by a government entity with commission of any of the offenses enumerated herein; and
- d. Have not within a three-year period preceding this bid proposal and/or application had one or more public transactions terminated for cause or default.

Signature: _____
Print Name: _____
Title: _____
Telephone Number: _____
Date: _____

If the bidder is unable to certify to all of the statements in this Certification, such bidder should attach an explanation to this proposal.

EXHIBIT "G"
APPENDICES

APPENDIX A

During the performance of this contract, the contractor, for itself, its assignees, and successors in interest (hereinafter referred to as the "contractor") agrees as follows:

1. **Compliance with Regulations:** The contractor (hereinafter includes consultants) will comply with the Acts and the Regulations relative to Nondiscrimination in Federally-assisted programs of the U.S. Department of Transportation, the Federal Highway Administration, as they may be amended from time to time, which are herein incorporated by reference and made a part of this contract.
2. **Nondiscrimination:** The contractor, with regard to the work performed by it during the contract, will not discriminate on the grounds of race, color, or national origin in the selection and retention of subcontractors, including procurements of materials and leases of equipment. The contractor will not participate directly or indirectly in the discrimination prohibited by the Acts and the Regulations, including employment practices when the contract covers any activity, project, or program set forth in Appendix B of 49 CFR Part 21.
3. **Solicitations for Subcontracts, Including Procurements of Materials and Equipment:** In all solicitations, either by competitive bidding, or negotiation made by the contractor for work to be performed under a subcontract, including procurements of materials, or leases of equipment, each potential subcontractor or supplier will be notified by the contractor of the contractor's obligations under this contract and the Acts and the Regulations relative to Nondiscrimination on the grounds of race, color, or national origin.
4. **Information and Reports:** The contractor will provide all information and reports required by the Acts, the Regulations, and directives issued pursuant thereto and will permit access to its books, records, accounts, other sources of information, and its facilities as may be determined by the Recipient or the Federal Highway Administration to be pertinent to ascertain compliance with such Acts, Regulations, and instructions. Where any information required of a contractor is in the exclusive possession of another who fails or refuses to furnish the information, the contractor will so certify to the Recipient or the Federal Highway Administration, as appropriate, and will set forth what efforts it has made to obtain the information.
5. **Sanctions for Noncompliance:** In the event of a contractor's noncompliance with the Nondiscrimination provisions of this contract, the Recipient will impose such contract sanctions as it or the Federal Highway Administration may determine to be appropriate, including, but not limited to:
 - a. withholding payments to the contractor under the contract until the contractor complies; and/or
 - b. cancelling, terminating, or suspending contract, in whole or in part.
6. **Incorporation of Provisions:** The contractor will include the provisions of paragraphs one through six in every subcontract, including procurements of materials and leases of equipment, unless exempt by the Acts, the Regulations and directives issued pursuant thereto. The contractor will take action with respect to any subcontract or procurement as the Recipient or the Federal Highway Administration may direct as a means of enforcing such provisions including sanctions for noncompliance. Provided, that if the contractor becomes involved in, or is threatened with litigation by a subcontractor, or supplier because of such direction, the contractor may request the Recipient to enter into any litigation to protect the interests of the Recipient. In addition, the contractor may request the United States to enter into the litigation to protect the interests of the United States.

APPENDIX B

CLAUSES FOR DEEDS TRANSFERRING UNITED STATES PROPERTY

The following clauses will be included in deeds effecting or recording the transfer of real property, structures, or improvements thereon, or granting interest therein from the United States pursuant to the provisions of Assurance 4:

NOW, THEREFORE, the U.S. Department of Transportation as authorized by law and upon the condition that the **COUNTY OF HIDALGO** will accept title to the lands and maintain the project constructed thereon in accordance with all applicable federal statutes, the Regulations for the Administration of all Department of Transportation programs, and the policies and procedures prescribed by the Federal Highway Administration of the U.S. Department of Transportation in accordance and in compliance with all requirements imposed by Title 49, Code of Federal Regulations, U.S. Department of Transportation, Subtitle A, Office of the Secretary, Part 21, Nondiscrimination in Federally-assisted programs of the U.S. Department of Transportation pertaining to and effectuating the provisions of Title VI of the Civil Rights Act of 1964 (78 Stat. 252; 42 U.S.C. § 2000d to 2000d-4), does hereby remise, release, quitclaim and convey unto the **COUNTY OF HIDALGO** all the right, title and interest of the U.S. Department of Transportation in and to said lands described in Exhibit 1 attached hereto and made a part hereof.

(HABENDUM CLAUSE)

TO HAVE AND TO HOLD said lands and interests therein unto **COUNTY OF HIDALGO** and its successors forever, subject, however, to the covenants, conditions, restrictions and reservations herein contained as follows, which will remain in effect for the period during which the real property or structures are used for a purpose for which Federal financial assistance is extended or for another purpose involving the provision of similar services or benefits and will be binding on the **COUNTY OF HIDALGO**, its successors and assigns.

The **COUNTY OF HIDALGO**, in consideration of the conveyance of said lands and interests in lands, does hereby covenant and agree as a covenant running with the land for itself, its successors and assigns, that (1) no person will on the grounds of race, color, or national origin, be excluded from participation in, be denied the benefits of, or be otherwise subjected to discrimination with regard to any facility located wholly or in part on, over, or under such lands hereby conveyed [,] [and]* (2) that the **COUNTY OF HIDALGO** will use the lands and interests in lands and interests in lands so conveyed, in compliance with all requirements imposed by or pursuant to Title 49, Code of Federal Regulations, U.S. Department of Transportation, Subtitle A, Office of the Secretary, Part 21, Nondiscrimination in Federally-assisted programs of the U.S. Department of Transportation, Effectuation of Title VI of the Civil Rights Act of 1964, and as said Regulations and Acts may be amended[, and(3) that in the event of breach of any of the above-mentioned nondiscrimination conditions, the Department will have a right to enter or re-enter said lands and facilities on said land, and that above described land and facilities will thereon revert to and vest in and become the absolute property of the U.S. Department of Transportation and its assigns as such interest existed prior to this instruction].*

(*Reverted clause and related language to be used only when it is determined that such a clause is necessary in order to make clear the purpose of Title VI.)

APPENDIX C

CLAUSES FOR TRANSFER OF REAL PROPERTY ACQUIRED OR IMPROVED UNDER THE ACTIVITY, FACILITY, OR PROGRAM

The following clauses will be included in deeds, licenses, leases, permits, or similar instruments entered into by the **COUNTY OF HIDALGO** pursuant to the provisions of Assurance 7(a):

- A. The (grantee, lessee, permittee, etc. as appropriate) for himself/herself, his/her heirs, personal representatives, successors in interest, and assigns, as a part of the consideration hereof, does hereby covenant and agree [in the case of deeds and leases add "as a covenant running with the land"] that:
 1. In the event facilities are constructed, maintained, or otherwise operated on the property described in this (deed, license, lease, permit, etc.) for a purpose for which a U.S. Department of Transportation activity, facility, or program is extended or for another purpose involving the provision of similar services or benefits, the (grantee, licensee, lessee, permitted, etc.) will maintain and operate such facilities and services in compliance with all requirements imposed by the Acts and Regulations (as may be amended) such that no person on the grounds of race, color, or national origin, will be excluded from participation in, denied the benefits of, or be otherwise subjected to discrimination in the use of said facilities.
- B. With respect to licenses, leases, permits, etc., in the event of breach of any of the above Nondiscrimination covenants, **COUNTY OF HIDALGO** will have the right to terminate the (lease, license, permit, etc.) and to enter, re-enter, and repossess said lands and facilities thereon, and hold the same as if the (lease, license, permit, etc.) had never been made or issued.*
- C. With respect to a deed, in the event of breach of any of the above Nondiscrimination covenants, the **COUNTY OF HIDALGO** will have the right to enter or re-enter the lands and facilities thereon, and the above described lands and facilities will there upon revert to and vest in and become the absolute property of the **COUNTY OF HIDALGO** and its assigns.*

(*Reverted clause and related language to be used only when it is determined that such a clause is necessary in order to make clear the purpose of Title VI.)

APPENDIX D

CLAUSES FOR CONSTRUCTION/USE/ACCESS TO REAL PROPERTY ACQUIRED UNDER THE ACTIVITY, FACILITY OR PROGRAM

The following clauses will be included in deeds, licenses, permits, or similar instruments/agreements entered into by **COUNTY OF HIDALGO** pursuant to the provisions of Assurance 7(b):

- A. The (grantee, licensee, permittee, etc., as appropriate) for himself/herself, his/her heirs, personal representatives, successors in interest, and assigns, as a part of the consideration hereof, does hereby covenant and agree (in the case of deeds and leases add, "as a covenant running with the land") that (1) no person on the ground of race, color, or national origin, will be excluded from participation in, denied the benefits of, or be otherwise subjected to discrimination in the use of said facilities, (2) that in the construction of any improvements on, over, or under such land, and the furnishing of services thereon, no person on the ground of race, color, or national origin, will be excluded from participation in, denied the benefits of, or otherwise be subjected to discrimination, (3) that the (grantee, licensee, lessee, permittee, etc.) will use the premises in compliance with all other requirements imposed by or pursuant to the Acts and Regulations, as amended, set forth in this Assurance.
- B. With respect to (licenses, leases, permits, etc.), in the event of breach of any of the above Nondiscrimination covenants, **COUNTY OF HIDALGO** will have the right to terminate the (license, permit, etc., as appropriate) and to enter or re-enter and repossess said land and the facilities thereon, and hold the same as if said (license, permit, etc., as appropriate) had never been made or issued.*
- C. With respect to deeds, in the event of breach of any of the above Nondiscrimination covenants, **COUNTY OF HIDALGO** will there upon revert to and vest in and become the absolute property of **COUNTY OF HIDALGO** and its assigns.*

(*Reverted clause and related language to be used only when it is determined that such a clause is necessary in order to make clear the purpose of Title VI.)

APPENDIX E

During the performance of this contract, the contractor, for itself, its assignees, and successors in interest (hereinafter referred to as the "contractor") agrees to comply with the following nondiscrimination statutes and authorities; including but not limited to:

Pertinent Nondiscrimination Authorities:

- Title VI of the Civil Rights Act of 1964 (42 U.S.C. § 2000d et seq., 78 stat. 252), (prohibits discrimination on the basis of race, color, national origin); and 49CFR Part 21.
- The Uniform Relocation Assistance and Real Property Acquisition Policies Act of 1970, (42U.S.C. § 4601), (prohibits unfair treatment of persons displaced or whose property has been acquired because of Federal or Federal-aid programs and projects);
- Federal-Aid Highway Act of 1973, (23U.S.C. § 324et seq.), (prohibits discrimination on the basis of sex);
- Section 504 of the Rehabilitation Act of 1973, (29U.S.C. § 794 et seq.), as amended, (prohibits discrimination on the basis of disability); and 49CFRPart 27;
- The Age Discrimination Act of 1975, as amended,(42U.S.C. § 6101 et seq.), (prohibits discrimination on the basis of age);
- Airport and Airway Improvement Act of 1982, (49U.S.C. § 4 71, Section 4 7123),as amended, (prohibits discrimination based on race, creed, color, national origin, or sex);
- The Civil Rights Restoration Act of 1987,(PL 100-209), (Broadened the scope, coverage and applicability of Title VI of the Civil Rights Act of 1964, The Age Discrimination Act of 1975 and Section 504 of the Rehabilitation Act of 1973, by expanding the definition of the terms "programs or activities" to include all of the programs or activities of the Federal-aid recipients, sub recipients and contractors, whether such programs or activities are Federally funded or not);
- Titles II and III of the Americans with Disabilities Act, which prohibit discrimination on the basis of disability in the operation of public entities, public and private transportation systems, places of public accommodation, and certain testing entities (42 U.S.C. §§ 12131-12189)as implemented by Department of Transportation regulations at 49C.F.R. parts 37 and 38;
- The Federal Aviation Administration's Nondiscrimination statute (49U.S.C. § 47123) (prohibits discrimination on the basis of race, color, national origin, and sex);
- Executive Order 12898, Federal Actions to Address Environmental Justice in Minority Populations and Low-Income Populations, which ensures discrimination against minority populations by discouraging programs, policies, and activities with disproportionately high and adverse human health or environmental effects on minority and low-income populations;
- Executive Order 13166, Improving Access to Services for Persons with Limited English Proficiency, and resulting agency guidance, national origin discrimination includes discrimination because of limited English proficiency (LEP). To ensure compliance with Title VI, you must take reasonable steps to ensure that LEP persons have meaningful access to your programs (70 Fed. Reg. at 74087 to 74100);
- Title IX of the Education Amendments of 1972, as amended, which prohibits you from discriminating because of sex in education programs or activities (20 U .S.C. 1681 et seq).

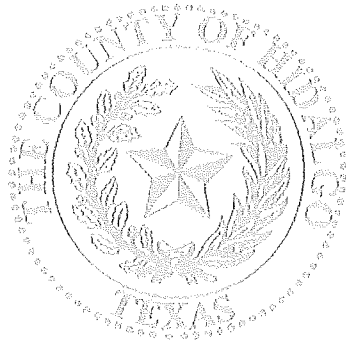

HIDALGO COUNTY

(Including all funding sources, programs, and entities)

**REQUEST FOR SEALED QUOTES
“GARBAGE COLLECTION FOR NEW SAN CARLOS CRC”
RFSQ No.: 2017-097-03-06-SGS**

RFSQ SUBMITTAL CHECK LIST

All forms listed below must be included in the RFSQ response.

Indicate with a check mark (✓) the Forms completed and included in this response:

- Page 9 of Legal Notice
- Exhibit “B” Quote Page
- Exhibit “C” Insurance and Project Acknowledgement forms
- Exhibit “D” CIQ Form -Copy of Co. Clerk Recording fee receipt (if applicable)
- Exhibit “E” Vendor Bidder Applications and IRS form W-9
- Exhibit “F” Certification Regarding Debarment
- SAMS.gov Registration Acknowledgement www.sam.gov (provide DUNS Number)
- Copy of required Permits/Certificates , as per Exhibit “A”

EXHIBIT "B"
VENDOR'S BID PRICE

EXHIBIT "B"
HIDALGO COUNTY PRECINCT NO. 4
"GARBAGE COLLECTION AT NEW SAN CARLOS CRC"
RFSQ NO.: 2017-097-03-06-SGS

QUOTE PAGE

PART I

AWARD WILL BE BASED ON THE LOWEST & BEST BID MEETING ALL SPECIFICATIONS / REQUIREMENTS.
Internal Use Only: Commodity Code: 910-27

LOCATION SITE:	
SAN CARLOS COMMUNITY RESOURCE CENTER - HIDALGO COUNTY PRECINT # 4	
	COST
Charges for <u>One (1) day per Week Collection Service</u>	Total Monthly Cost \$ 93.50
Additional Charges – (specify below)	\$ 137.00
Specify Additional Fee: DELIVERY FEE (ONE TIME CHARGE)	
CONTAINER TO BE PROVIDED BY VENDOR	Container As per Specifications
<u>Slant top-Container</u> - (1) with lid (as per Specs- 5'6" L x 6' W x 5'H or equal 4 cubic yds.	Yes - <input checked="" type="checkbox"/>
	No - <input checked="" type="checkbox"/>
<u>Flat top-Container</u> - (1) with lid Indicate Dimensions – (must be 4 cubic yards-fit in Holding Area)	
Copies of Documents authorizing Vendor to dispose of solid waste in Landfill, as per Exhibit A-Specifications - (if applicable)	Enclosed (✓)
	YES

LANDFILL SITE ADDRESS/LOCATION:

LA GLORIA RANCH LANDFILL, 23485 N MOOREFIELD RD, EDINBURG TX 78541

RFSQ
for
HIDALGO COUNTY PRECINCT NO. 4
“GARBAGE COLLECTION AT THE NEW SAN CARLOS CRC BLDG”
RFSQ No: 2017-097-03-06-SGS

To: Martha L. Salazar, CPPB, Purchasing Agent
Hidalgo County Purchasing Department
Sandy Suarez, Buyer II
Physical Address: 2802 S. Business Hwy. 281 - Administration Building
Mailing/Postal Address: 2812 S. Business Hwy. 281
Edinburg, Texas 78539

In accordance with the Specifications, and subject to all laws and regulations of the United States and state and local laws, the undersigned Participant proposes and commits to furnish all labor, equipment, material, software and services as set forth in the documents hereinbefore mentioned. The undersigned Participant further agrees, upon acceptance of its RFSQ, to execute a contract and/or Purchase Order issued by Hidalgo County for performing and completing the work described in the Specifications within the time stated and for the prices proposed in the documents attached hereto and made a part hereof.

Participant acknowledges receipt of all of the pages of the documents referenced in the Invitation to RFSQ Checklist presented in connection with this procurement. Participant understands that Hidalgo County reserves the right to reject any or all RFSQs and further reserves the right to design the evaluation criteria to be used in selecting the lowest and best RFSQ.

Participant agrees that this RFSQ shall be good and may not be withdrawn for a period of thirty (30) calendar days after the scheduled closing time for receiving RFSQs, as contained in the Specifications.

Respectfully submitted,

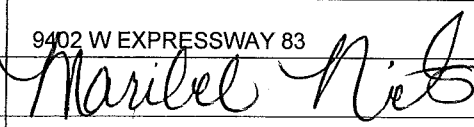
Participant:	REPUBLIC SERVICES
Address:	9402 W EXPRESSWAY 83
By:	
Printed Name:	MARIBEL NIETO
Title:	INSIDE SALES REPRESENTATIVE

Must be submitted with the quote

Front Loading Container Specifications

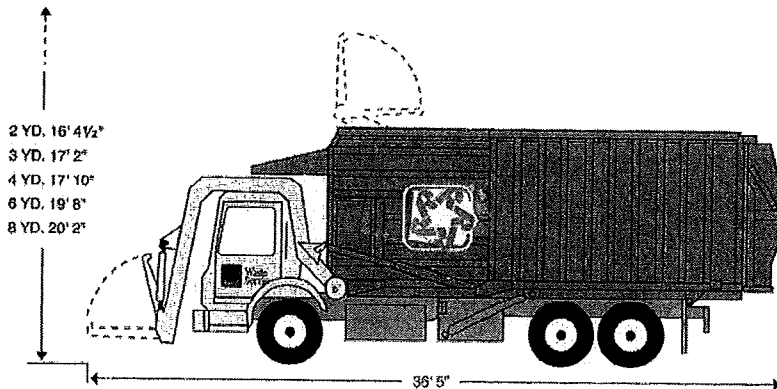
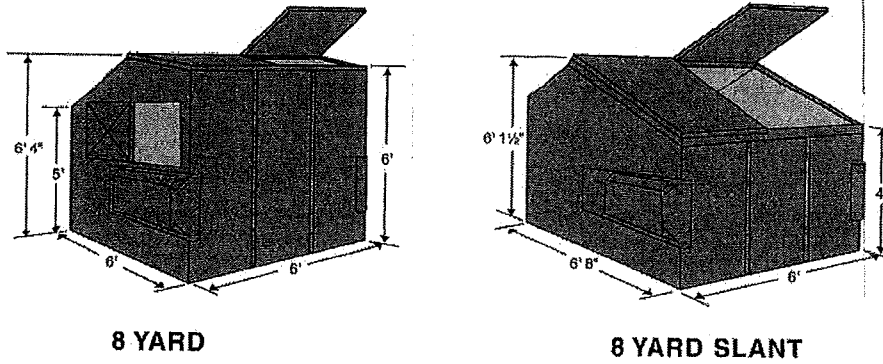
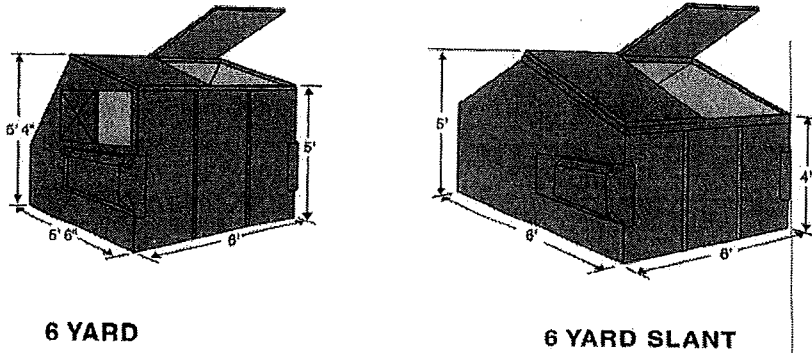
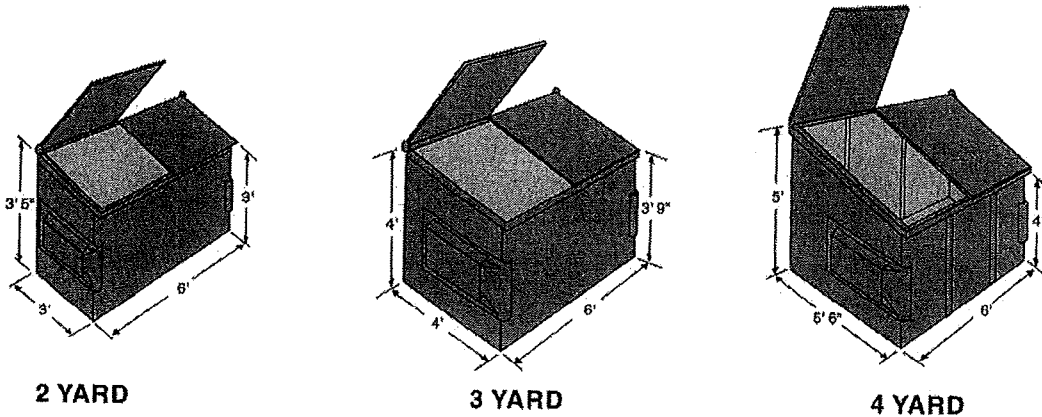

COLLECTION VEHICLE CONFIGURATION

Note: Approximate specifications subject to change without notice.

EXHIBIT "C"
INSURANCE REQUIREMENTS

CERTIFICATE OF INTERESTED PARTIES

FORM 1295

1 of 1

Complete Nos. 1 - 4 and 6 if there are interested parties.
Complete Nos. 1, 2, 3, 5, and 6 if there are no interested parties.

**OFFICE USE ONLY
CERTIFICATION OF FILING**

Certificate Number:
2017-175144

Date Filed:
03/06/2017

Date Acknowledged:
03/07/2017

1 Name of business entity filing form, and the city, state and country of the business entity's place of business.

Republic Services
Harlingen, TX United States

2 Name of governmental entity or state agency that is a party to the contract for which the form is being filed.

Hidalgo County

3 Provide the identification number used by the governmental entity or state agency to track or identify the contract, and provide a description of the services, goods, or other property to be provided under the contract.

RFSQ NO.: 2017-097-03-06-SGS
Solid waste removal and disposal

4 Name of Interested Party	City, State, Country (place of business)	Nature of interest (check applicable)	
		Controlling	Intermediary
Republic Services	Harlingen, TX United States	X	

5 Check only if there is NO Interested Party.

6 AFFIDAVIT I swear, or affirm, under penalty of perjury, that the above disclosure is true and correct.

Signature of authorized agent of contracting business entity

AFFIX NOTARY STAMP / SEAL ABOVE

Sworn to and subscribed before me, by the said _____, this the _____ day of _____, 20_____, to certify which, witness my hand and seal of office.

Signature of officer administering oath Printed name of officer administering oath Title of officer administering oath

CERTIFICATE OF INTERESTED PARTIES

FORM 1295

1 of 1

Complete Nos. 1 - 4 and 6 if there are interested parties.
Complete Nos. 1, 2, 3, 5, and 6 if there are no interested parties.

OFFICE USE ONLY CERTIFICATION OF FILING

Certificate Number:
2017-175144

Date Filed:
03/06/2017

Date Acknowledged:

1 Name of business entity filing form, and the city, state and country of the business entity's place of business.

Republic Services
Harlingen, TX United States

2 Name of governmental entity or state agency that is a party to the contract for which the form is being filed.

Hidalgo County

3 Provide the identification number used by the governmental entity or state agency to track or identify the contract, and provide a description of the services, goods, or other property to be provided under the contract.

RFSQ NO.: 2017-097-03-06-SGS
Solid waste removal and disposal

4	Name of Interested Party	City, State, Country (place of business)	Nature of interest (check applicable)	
			Controlling	Intermediary
	Republic Services	Harlingen, TX United States	X	

5 Check only if there is NO Interested Party.

6 AFFIDAVIT

I swear, or affirm, under penalty of perjury, that the above disclosure is true and correct.

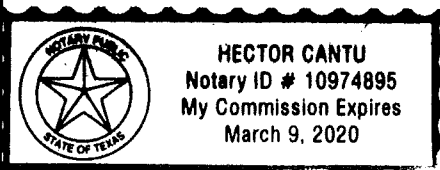

Maibela Nieto
Signature of authorized agent of contracting business entity

AFFIX NOTARY STAMP / SEAL ABOVE

Sworn to and subscribed before me, by the said Maibela Nieto, this the 6th day of March, 2017, to certify which, witness my hand and seal of office.

[Signature] Signature of officer administering oath
 Hector Cantu Printed name of officer administering oath
 District Attorney Title of officer administering oath