

JACQUEZ RESIDENCE

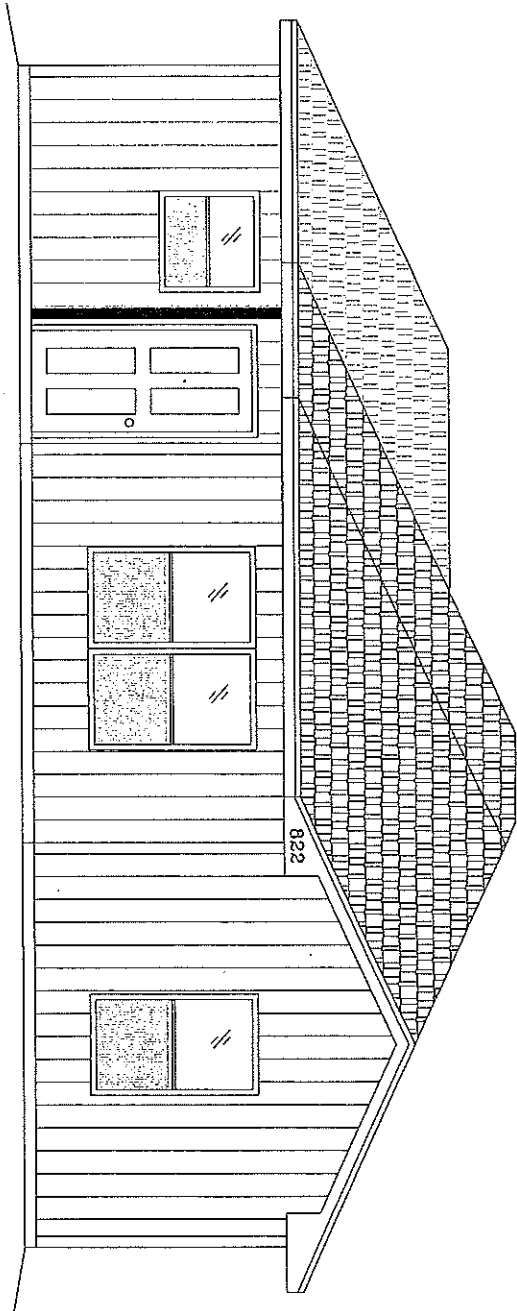

SUSANA JACQUEZ
882 N. VERMONT AVE.
MERCEDDES, TEXAS 78570
CELL: 956-274-1895

URBAN COUNTY PROGRAM
427 E. DURANTA STE 107 - ALAMO
(956) 787-8127

URBAN COUNTY PROGRAM
OWNER OCCUPIED HOUSING REHABILITATION PROGRAM

SUSANA JACQUEZ
822 N. VERMONT AVE., MERCEDDES TX.

TOTAL AREA
992 SQ. FT.

C1.0

1 ROOF/PLOT PLAN

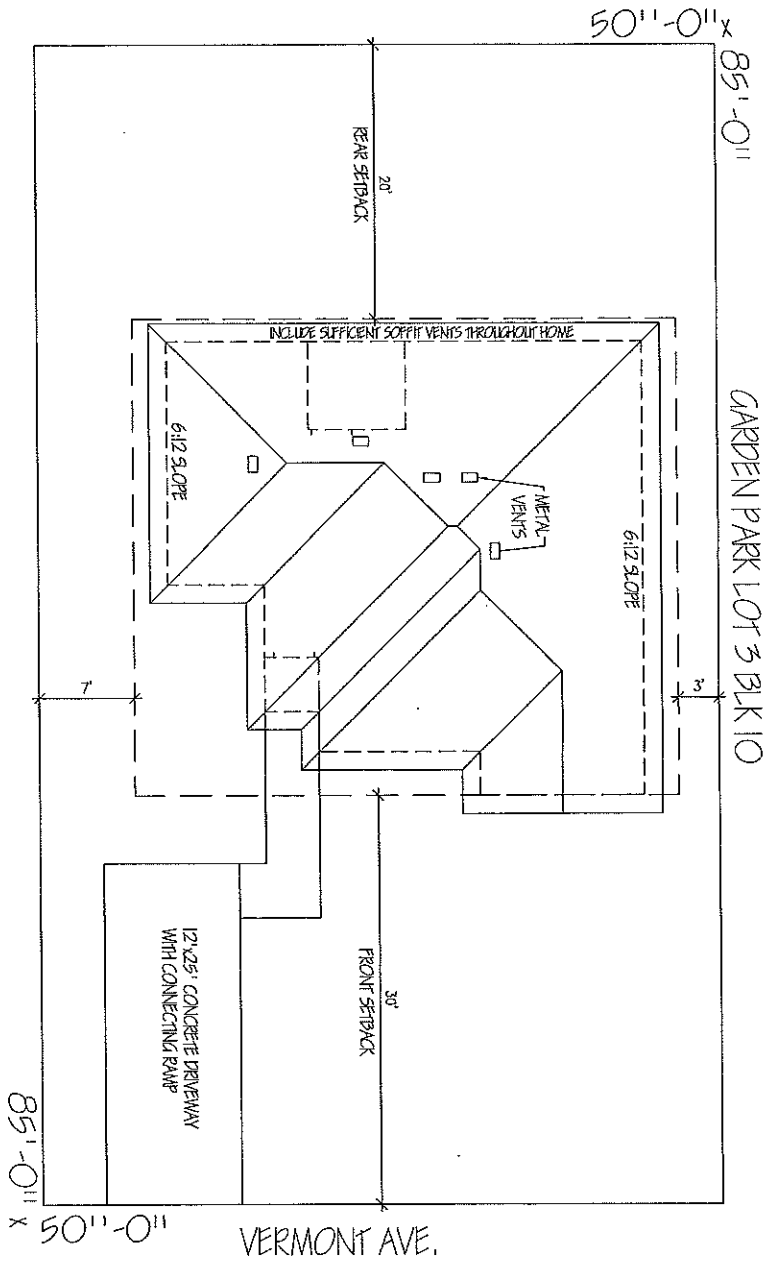

NOTE:

1. Please verify with city/ county on setbacks and for any requirements regarding sidewalk, driveway, landscaping, and any other obligations as per city regulations/ ordinances.
2. It is the responsibility of the Contractor to locate the rods and string the property. To avoid any problems it is now required and the responsibility of the Contractor to order a property survey by a professional engineer.
3. Any house that is made for handicap accessibility WILL ALWAYS require driveway with connecting sidewalk.
4. Provide 6" of landscape dirt around house with sufficient grass seed up to 10' of perimeter. In addition, remember to replace septic tank if needed and is more than 10 yrs old.

URBAN COUNTY PROGRAM
OWNER OCCUPIED HOUSING REHABILITATION PROGRAM

SUSANA JACQUEZ
822 N. VERMONT AVE., MERCEDES TX.

TOTAL AREA
992 SQ. FT.

AS1.1

1 FLOOR PLAN
3/16" = 1'-0"

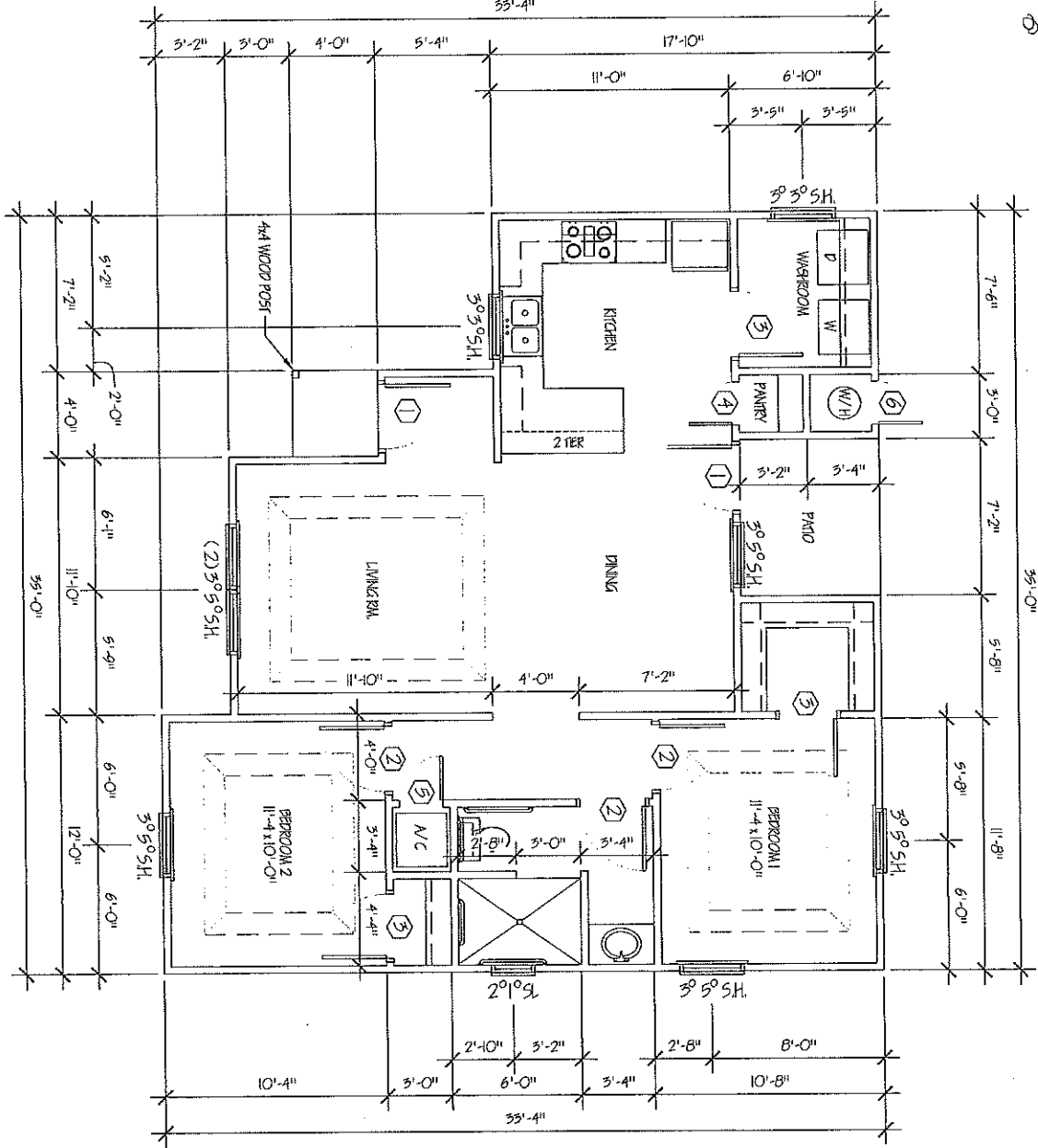

I HAVE READ AND FULLY AGREE WITH THE WRITE-UP AND PLANS AS PRESENTED TO ME THIS 15th DAY OF NOVEMBER 2007

[Signature]

GENERAL NOTES

6-1/2 SLOPE WITH 18" OVERHANG
 -INSTALL PORCH RAILINGS WHERE NEEDED
 -INSTALL PORCH STEPS WHERE NEEDED
 -INSTALL PORCH STEPS WHERE THERE IS A CHANGE IN FLOOR LEVEL
 -CLIENT IS REQUESTING CONNECTIONS FOR A GAS/ELECTRIC SHOWER
 -INSTALL A HANG OF RING PHONE JACKS & CABLE CONNECTIONS AS PER OWNERS REQUEST.
 -EXTERIOR COLOR CHOICES TO BE OR MATCH

Swagard Swagard Swagard

INTERIOR COLOR CHOICES TO BE OR MATCH
Swagard Swagard

Dark stain cabinets
 Beige VCT flooring

PR#	TASK	SIZE	TYPE	LOCKS
1	INSTALL NEW/INSTR W/ DOOR REPAIRS	30	HEAVY W/ LOW PROFILE TRACK	LEVER TYPE SHUNT LOCKS W/ DEADBOLT
2	INSTALL NEW/INSTR	30	HOLLOW CORE	LEVER TYPE FINANCY
3	INSTALL NEW/INSTR	28	HOLLOW CORE	PASSAGE
4	INSTALL NEW/INSTR	20	HOLLOW CORE	PASSAGE
5	INSTALL NEW/INSTR	20 x 40	HOLLOW CORE	N/C DOOR PASSAGE
6	INSTALL NEW/INSTR	20	HOLLOW HEAVY	LOCK W/ DEADBOLT

SQUARE FOOTAGE

LIVING AREA	990
PORCH/ PANO	62
TOTAL SQ. FT.	992

URBAN COUNTY PROGRAM
 OWNER OCCUPIED HOUSING REHABILITATION PROGRAM

SUSANA JACQUEZ
 822 N. VERMONT AVE., MERCEDES TX.

TOTAL AREA
 992 SQ. FT.

2 REAR ELEVATION

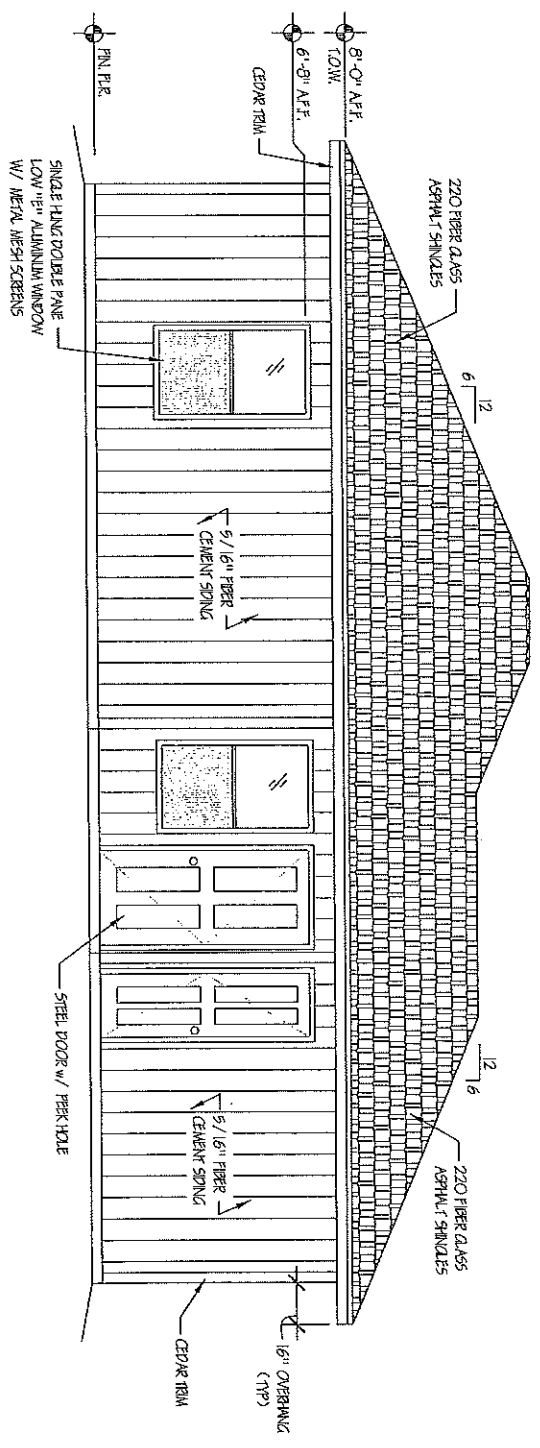

1 FRONT ELEVATION

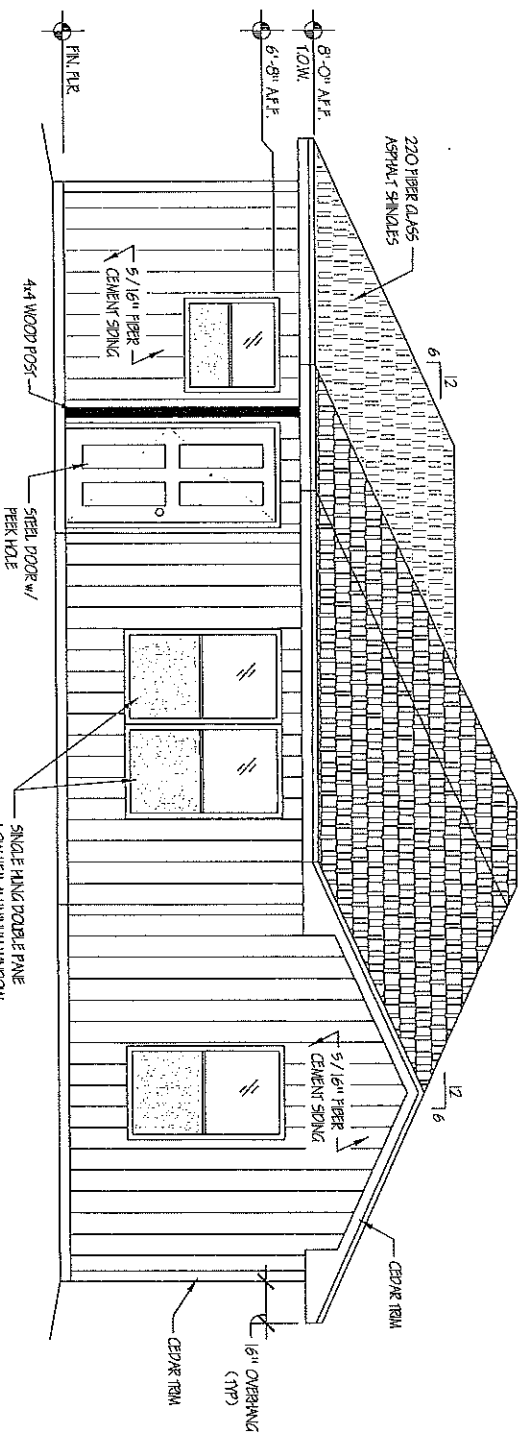

URBAN COUNTY PROGRAM OWNER OCCUPIED HOUSING REHABILITATION PROGRAM		
SUSANA JACQUEZ 822 N. VERMONT AVE., MERCEDES TX.	TOTAL AREA 992 SQ. FT.	
A1.2		

2 LEFT ELEVATION

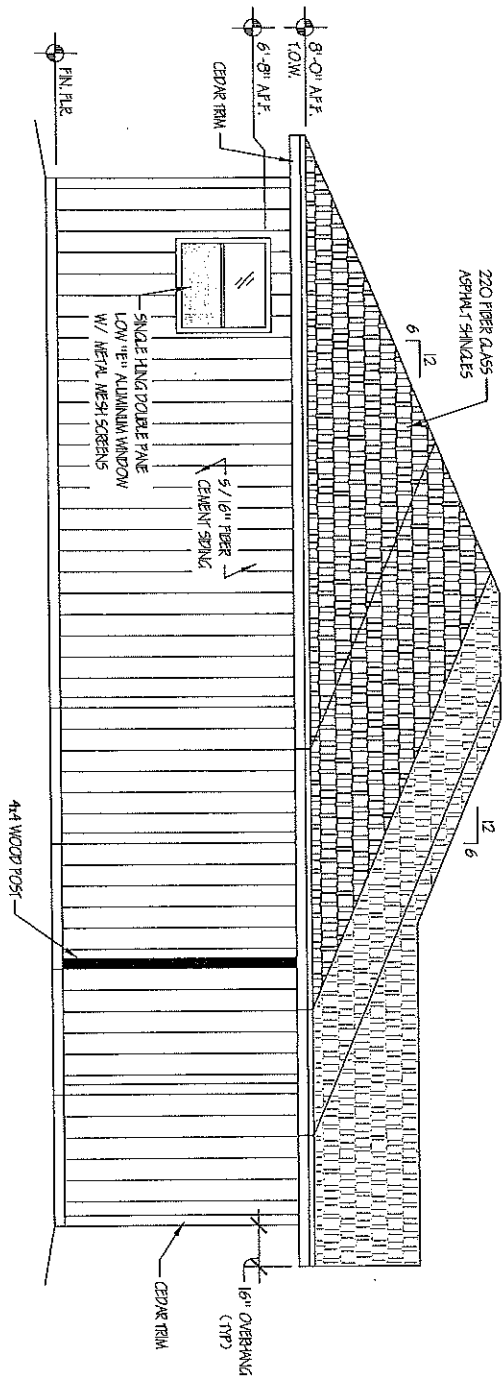

1 RIGHT ELEVATION

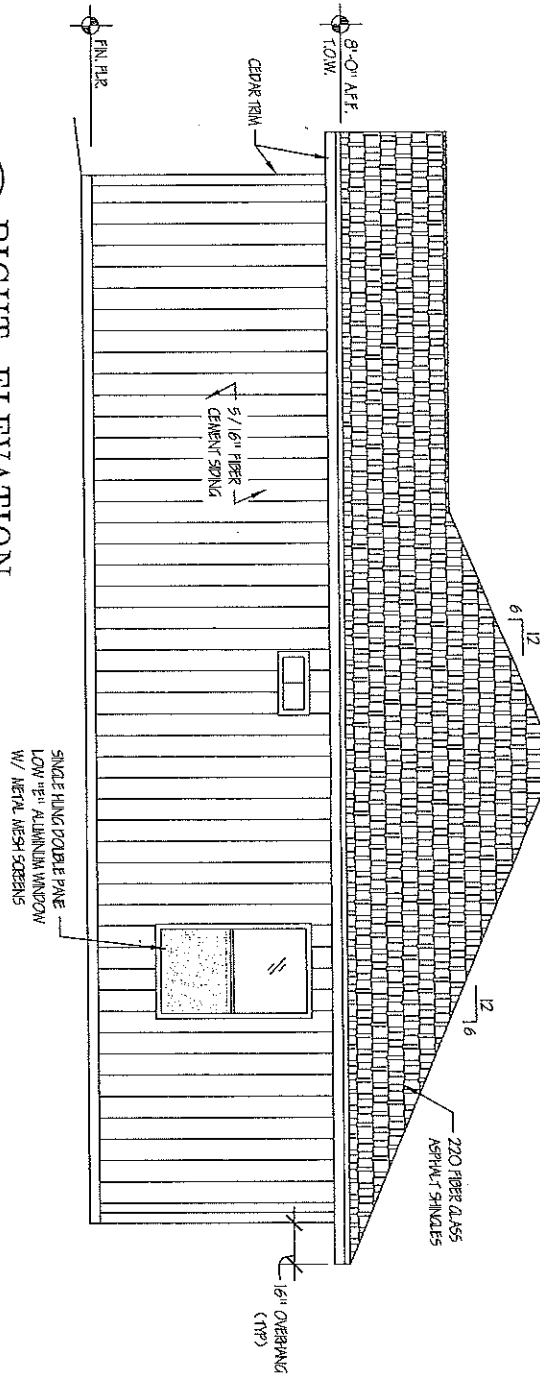

URBAN COUNTY PROGRAM OWNER OCCUPIED HOUSING REHABILITATION PROGRAM		
A1.3	SUSANA JACQUEZ 822 N. VERMONT AVE., MERCEDES TX.	TOTAL AREA 992 SQ. FT.

1
 3/16" = 1'-0"
 ELECTRICAL PLAN

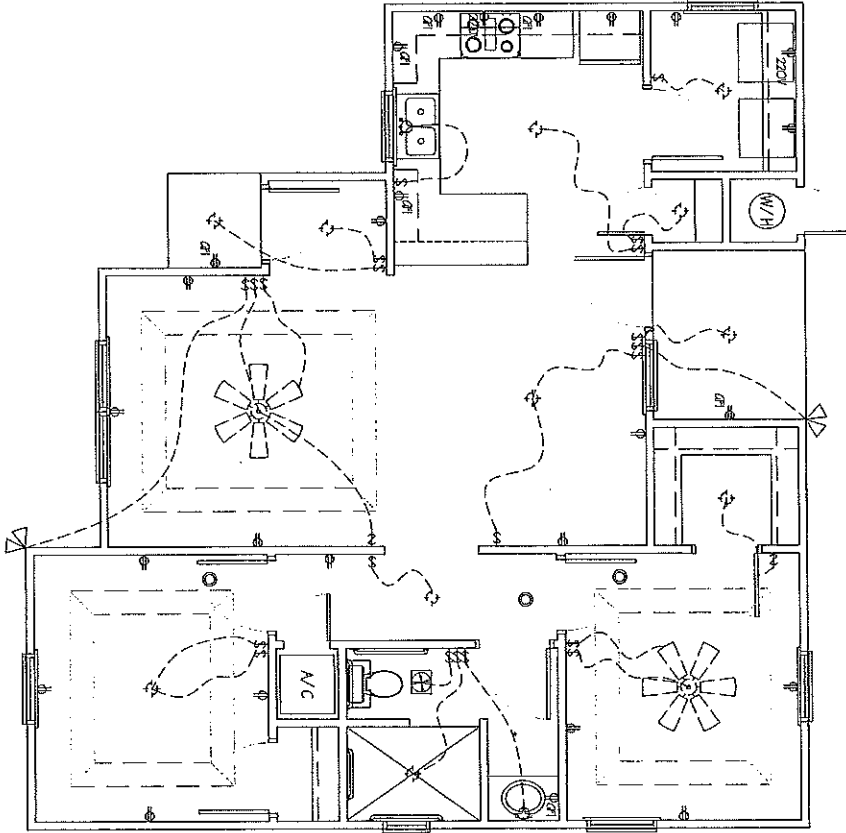

ELECTRICAL LEGEND

(WH)	WATER HEATER	↔	LIGHT FIXTURE
⊕	220V ELECTRICAL RECEPT.	\$	LIGHT SWITCH
⊕	220V DUPLEX	□	THERMOSTAT
⊕	220V ELECTRICAL RECEPT.	○	SMOKE DETECTOR
⊕	GROUND FAULT CREDIT INTERRUPTER	▽	SECURITY LIGHTS
⊕	BATHROOM EXHAUST FAN		

URBAN COUNTY PROGRAM
 OWNER OCCUPIED HOUSING REHABILITATION PROGRAM

SUSANA JACQUEZ
 822 N. VERMONT AVE., MERCEDES TX.

TOTAL AREA
 992 SQ. FT.

E1.1

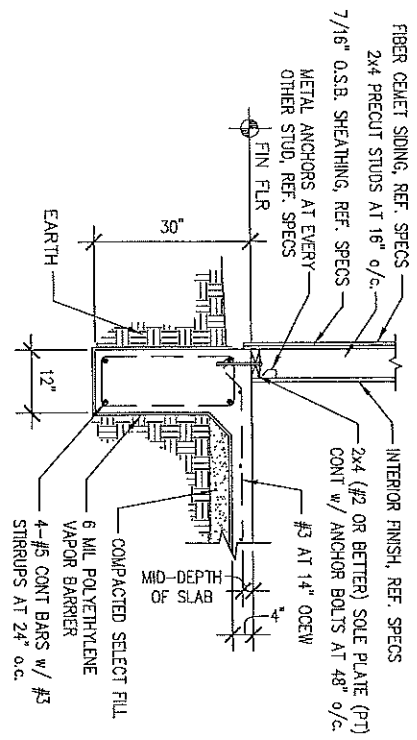

A-EXTERIOR BEAM

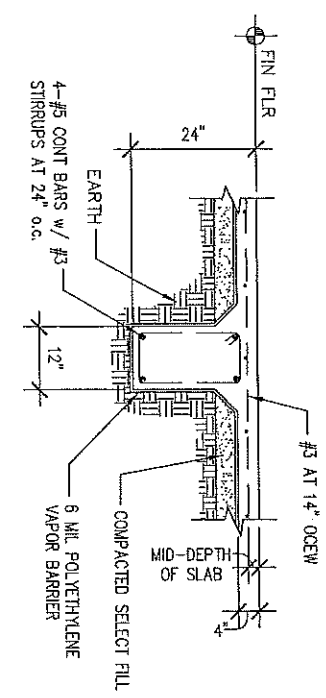

B-INTERIOR BEAM

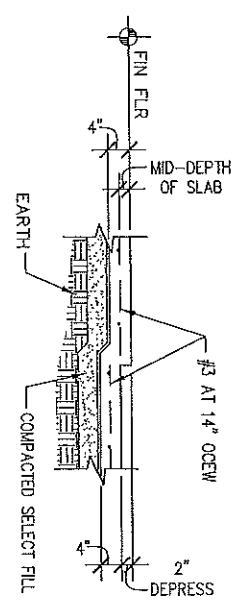

C-SHOWER DEPRESS

	URBAN COUNTY PROGRAM OWNER OCCUPIED HOUSING REHABILITATION PROGRAM	
S2.2	SUSANA JACQUEZ 822 N. VERMONT AVE., MERCEDES TX.	TOTAL AREA 992 SQ. FT.

SPECIFICATIONS

ALL SPECIFICATIONS SHALL ASSUME THE USE OF CONTRACTOR'S MINIMUM GENERAL SPECIFICATIONS MANUAL

OWNER (S) SUSANA JACQUEZ CASE NO.: MBS0-17-02 DATE: 11/8/17 ADDRESS: 822 N VERMONT AVE, MERCEDES TX PHONE: 956-274-1895 BY: ROBERTO CAVAZOS

1. FOUNDATION WORK:

BUILD A NEW SLAB ON GRADE FOUNDATION TO COMPLY WITH PLANS, SPECS, CITY AND / COUNTY REQUIREMENTS. PROJECTS TO BE 18" ABOVE CENTER LINE OF STREET OR CURB OR 12" ABOVE NATURAL GROUND, WHICHEVER IS GREATER. PROVIDE CONCRETE SLAB FOR A/C UNIT. PROVIDE A MIN. OF 12 X 26 DRIVEWAY (depending on city).

2. PLUMBING GENERAL: (SEE SPECS)

ALL PLUMBING ROUGH SHALL BE AS FOLLOWS:

- > WATER SUPPLY TO HOUSE SHALL HAVE A 1/2" CUTOFF VALVE BEFORE ENTRY TO HOUSE
- > INTERIOR WATER SUPPLY LINES FOR HOUSE SHALL BE ALL NEW PEX OF APPROPRIATE DIAMETER
- > NEW PEX PIPES AND FITTINGS:
- OF 1" MINIMUM DIAMETER FOR ALL EXTERIOR WATER SUPPLY LINES BELOW GROUND.
- OF APPROPRIATE DIAMETER FOR DWV (DRAIN, WASTE, AND VENTS).

ALL PLUMBING FINISH SHALL BE AS FOLLOWS:

- > RELATED PLUMBING ITEMS:
- (2) EXTERIOR HOSE BRASS BIB FAUCETS.
- 1/2" CUTOFF VALVES WITH ESCUTCHEONS FOR ALL FIXTURES.
- PLUMBING SEALANT FOR ALL DRAINS, AND SINK PERIMETERS
- ALL OTHER RELATED PLUMBING (SEE SPECS)

- KITCHEN SINK W/ RELATED PLUMBING & FAUCETS
- BATHROOM SINK W/ RELATED PLUMBING & FAUCETS
- TOILET OF MATCHING COLOR
- SHOWER WITH RELATED PLUMBING AND HANDICAP ACCESSIBLE.
- SHOWER FAUCETS & REMOVABLE SHOWER HEAD
- MEDICINE CABINET/STOVEL RACKS/T.P. DISPENSER & SHOWER ROD (SEE SPECS)
- WATER HEATER INSTALLED AS PER SPECS. (GAS OR ELECTRIC AS PER OWNER REQUEST)

OTHER RELATED ITEMS

- RANGE CONNECTIONS AS PER OWNERS REQUEST (SEE SECTION 23)
- 4" DRYER EXHAUST VENT.
- IN WALL WASHING MACHINE BOX WITH BRASS FAUCETS & RELATED PLUMBING.
- HOOK UP ALL DRAINAGE LINES TO CITY SEWER SYSTEM IF AVAILABLE. SEE CITY FOR IMPROVATION/TESTS. SEPTIC SYSTEM IF EXISTING FOR INTEGRITY AND REPLACE IF NECESSARY AND MORE THAN 10 YEARS OF AGE

3. INTERIOR/EXTERIOR WALLS &

CEILINGS:

- ALL INTERIOR AND EXTERIOR WALL FRAMING:
- > 2x4 (#2 OR BETTER) FOR USE IN: SOLE PLATES (TREATED LUMBER)
- DOUBLE TOP PLATES
- 92 #8 PRE-CUT BLOCKS @ 16" O.C.
- WINDOW SILLS
- CEILING JOIST CHAIN BLOCKS @ 48" O.C.
- > 2x6 (#2 OR BETTER) FOR USE IN:
- WINDOW & DOOR HEADERS WITH +1/2" PLYWOOD SPACER.
- CEILING JOIST @ 24" O.C. FOR CLEARANCES LARGER THAN 12'
- CEILING JOIST SHALL BE @ 16" O.C.

- INSTALL BOOTIES IN EVERY CORNER OF THE HOUSE ALONG WITH METAL ANCHORS ON BOTH BOTTOM AND TOP PLATES OF HOME
- ALL EXTERIOR CEILING COVERINGS:
- 3/8" CD EXTERIOR PLYWOOD FOR PORCH CEILINGS.
- 1/2" SHEETROCK FINISHED AS PER SPECS.
- 1/2" DAMP RESISTANT SHEETROCK FOR BATH AREAS.

ALL INTERIOR WALL & CEILING COVERINGS:

- ALL INTERIOR CEILINGS SHALL HAVE ORANGE PEEL TEXTURE.
- ALL INTERIOR WALL SURFACES SHALL HAVE ORANGE PEEL TEXTURE.
- ALL EXTERIOR TRIMMINGS SHOULD CONSIST OF CEDAR WOOD.

4. ROOF: (SLOPE=6/12)

- A HIPGABLE STYLE ROOF WITH 16" OVERHANGS.
- A HIPGABLE STYLE FRONT PORCH AS PER PLANS.
- PORCH COLUMNS MUST BE FASTENED TO CONCRETE.
- AN ADEQUATE COMBINATION OF RIDGE & SOFFIT VENTS WITH AIR CHUTES.
- ADEQUATE RAIN GUTTERS WITH DOWN SPOUTS FOR THE ROOF AREA THAT MAY AFFECT OWNERS.
- SHINGLES TO BE OF LIGHT COLOR (no black shingles)

5. PORCH & CANOPY FLOORS:

- THE HOUSE SHALL HAVE PORCH FLOORS AS FOLLOWS:
- A FRONT PORCH FLOOR.
- A SIBERBACK PORCH FLOOR.
- PROVIDE RAMP & (2) HANDRAILS TO EACH FRONT AND/OR SIDE PORCH STEPS

6. INSULATION:

- ALL LIVING AREA, CEILINGS WITH BLOWN IN INSULATION TO AN R-49 FACTOR. (mixed & combined R-30 & R-19 to meet requirement)
- HAVE RULER INSTALLED FOR EVERY 300 SQUARE FEET BEFORE FRAMING AND ROUGH-IN INSPECTION IS SCHEDULED.
- INSULATION FOAM SHALL BE USED AROUND ALL WINDOWS, WIRES, PLUMBING, ELECTRICAL, 2x4 BOTTOM PLATES AND ALL PENETRATED AREAS.
- ALL PERIMETER WALLS WITH R-4.5 F.F.S. BATT.
- ALL EXTERIOR PIPS EXPOSED TO WEATHER SHALL BE INSULATED.

7. INTERIOR FINISH:

- ALL TRIM SHALL BE INSTALLED AS PER SPECS.
- ALL PAINT SHALL BE APPLIED AS PER SPECS (2 COATS) WITH PAINT COMPARABLE IN QUALITY TO SHERWIN WILLIAMS. ALLOW A VARIETY OF DIFFERENT COLORS FOR CLIENT TO CHOOSE FROM. (2 COLOR CHOICE MIN)

8. EXTERIOR FINISH:

- PAINT ENTIRE HOUSE AS PER SPECS WITH PAINT COMPARABLE IN QUALITY TO SHERWIN WILLIAMS. PRIMER TO BE OIL BASED & PAINT MUST BE EQUIVALENT TO A-100 (2 COLOR CHOICE MIN).

9. SIDING:

- THE SIDING SHALL BE 5/8" FIBER CEMENT WITH ALL CEDAR TRIM TO ENTIRE HOUSE
- INSTALL 7/8" O.S.B. TO THE ENTIRE PERIMETER OF THE HOUSE AS PER MANUFACTURER'S SPECIFICATIONS.

10. WINDOWS:

SHALL BE NEW LOW-E DOUBLE PANE INSULATED ALUMINUM WINDOWS. SIZE AS PER PLAN. KEEP LABELS ON WINDOWS UNTIL FINAL INSPECTION HAS BEEN CLEARED.

11. CABINETS GENERAL:

- BUILD AND/OR INSTALL NEW KITCHEN CABINETS TO INCLUDE:
- > A RANGE CABINET.
- > A KITCHEN BATHROOM FORMICA COUNTER TOP OF MATCHING COLOR.
- BUILD AND/OR INSTALL A NEW VANITY CABINET (IF APPLICABLE) FOR BATHROOM WITH FORMICA TO MATCH LAVATORY SINK AND WALLS. ALL CABINERY PIECES SHOULD BE NEW AND COMPLETE AND BUILT TO PROFESSIONAL STANDARDS

12. FLOOR, SUBFLOOR, & FINISH FLOORING:

APPLY VOT FLOOR TILE TO ALL LIVING AREA HOUSE FLOORS.

13. ELECTRICAL GENERAL

- ALL ELECTRICAL INSTALLATIONS & WORK AS PER ELECTRICAL CODE WITH THE FOLLOWING CONDITIONS:
- > PROVIDE RANGE OUTLET AS PER OWNERS REQUEST.
- > PROVIDE APPROPRIATE WASHER & DRYER CONNECTION.
- > (2) 32 CEILING FANS (CEILING HUSKER STYLE) COMPARABLE IN QUALITY TO THE HUNTER BRAND. THE CONTRACTOR SHALL ALLOW \$120.00 FOR MATERIAL & LABOR. LOCATION AS PER OWNER REQUEST.
- > INSTALL SPEC. OUTLETS IN BATHROOMS, KITCHEN AND EXTERIOR WALLS.
- > EACH ELECTRICAL PANE OR BREAKER BOX, LIGHT SWITCH, & THERMOSTAT NO HIGHER THAN 48" ABOVE FLOOR
- > EACH ELECTRICAL PLUG TO BE 15' ABOVE THE FLOOR
- > ANY OUTLETS WITHIN 6' FROM KITCHEN OR BATHROOM SINKS MUST BE GFCI.

14. RANGE HOOD:

INSTALL A RANGE HOOD TO FIT OWNERS RANGE SIZE (30" OR 36") AND VENT TO EXTERIOR.

15. BATHROOM ACCESSORIES:

ALL ACCESSORIES & MEDICINE CABINETS AS PER SPECS. INCLUDE CURTAIN ROD & PLASTIC RETAINING DAM TO HELP PREVENT WATER FROM ESCAPING SHOWER. INSTALL CABINET ABOVE TOILET. ALSO INCLUDE TOILET PAPER HOLDER.

16. ACCESS FOR PHYSICAL DISABILITIES:

INSTALL ONE CONC. RAMP AS PER OWNERS REQUEST THAT CONNECTS WITH 12 X 23 DRIVEWAY AND STEPS WITH HANDRAILS. BATHROOM SHOULD ACCOMMODATE GRAB BARS WHERE INDICATED IN PLANS

17. HEATING & A/C:

PROVIDE & INSTALL A 16 SEER CENTRAL AIR CONDITIONING COMPARABLE IN QUALITY TO A CARRIER BRAND UNIT FOR THE ENTIRE HOUSE. INCLUDE DIGITAL THERMOSTAT.

18. SMOKE DETECTORS:

INSTALL A SMOKE DETECTOR INSIDE EACH SLEEPING ROOM OUTSIDE SLEEPING ROOMS. ALL WIRED IN SERIES

19. GENERAL NOTES.

CONTRACTOR IS RESPONSIBLE FOR:

- > YOU'RE BID TO INCLUDE ANY COST RELATED TO REQUIREMENTS FROM CITY. CHANGE ORDERS FOR THIS PARTICULAR PURPOSE WILL NOT BE ACCEPTED OR PROCESSED TO CORRECT THE ABOVE MENTIONED.
- > YOUR BID TO INCLUDE ANY COST RELATED TO RES-CHECK & ENERGY COMPLIANCE REQUIREMENTS.
- > THE DEMOLISH AND DISPOSAL OF EXISTING STRUCTURE. CONTRACTOR IS RESPONSIBLE FOR ANY DAMAGE TO EXISTING SIDEWALKS, DRIVEWAYS, AND UTILITY LINES DURING DEMOLITION.
- > THE COMPLIANCE OF ALL THE REQUIRED BUILDING ELEVATIONS.
- > PROVIDE 6" OF LANDSCAPE DIRT AROUND THE HOUSE ALONG WITH SUFFICIENT GRASS SEEDS UP TO 10' OF PERIMETER
- > PROVIDING THE APPROPRIATE ELECTRICAL AND IOR GAS CONNECTIONS FOR RANGE AS PER APPLICANT'S REQUEST AND ACCORDING TO APPLICABLE PLUMBING/ELECTRICAL CODE.
- > PROVIDE PHONE JACKS & CABLE CONNECTIONS IN EVERY BEDRM & LIVING SPACE. KITCHEN PHONE IF REQUESTED.
- > PROVIDE THERMATE PRE-TREATMENT TO ENTIRE FOUNDATION PAD.
- > OBTAINING, DISPLAYING, AND SUBMITTING ALL PROPER PERMITS & INSPECTIONS.
- > ALL CONTRACTORS WILL BE RESPONSIBLE FOR ANY ADDITIONAL PLANS, SPECIFICATIONS AND/OR DETAILS THAT ARE REQUIRED BY CITIES OR COUNTY AT THE TIME OF ATTAINING PERMITS.
- > MINIMUM 12x25 CONC. DRIVEWAY WITH CONNECTING SIDEWALK TO RAMP FOR HANDICAP APPLICANTS.
- > ALL THE GENERAL INFORMATION CONTAINED WITHIN SECTION 23. GENERAL NOTES OF THE CONTRACTORS GENERAL SPECIFICATIONS MANUAL.
- > PROVIDE AND INSTALL PROJECTS SIGNS AT EACH CONSTRUCTION SITE PRIOR TO THE START OF CONSTRUCTION. FINES WILL BE ENFORCED.
- > CONTRACTOR IS RESPONSIBLE FOR SUPPLYING PORT A POTTY THROUGHOUT CONSTRUCTION PROCESS (demo to final inspection) FINES WILL BE ENFORCED.
- > SHOWER ENTRANCES TO BE 36" WIDE
- > ALL UOP HOMES MUST COMPLY WITH TEXAS GOVERNMENT CODE §3206.514
- > REMOVE AND DISPOSE OF ALL DEBRIS ON SITE BEFORE THE BEGINNING OF CONSTRUCTION, INCLUDING BUT NOT LIMITED TO TIERS, ABANDONED VEHICLES, OLD LUMBER, ETC. MAKING NECESSARY DEPOSITS FOR ANY UTILITIES TO BE CONNECTED TO THE NEW DWELLING.

SPECIFICATIONS

ALL SPECIFICATIONS SHALL ASSUME THE USE OF CONTRACTOR'S MINIMUM GENERAL SPECIFICATIONS MANUAL

OWNER (S) SUSANA JACQUEZ CASE NO.: ME#50-17-02 DATE: 11/8/17 ADDRESS: 822 N. VERMONT AVE. MERCEDES TX. PHONE: 956-274-1895 BY: ROBERTO CAVAZOS

I HAVE READ AND FULLY AGREE WITH THE WRITEUP AND PLANS AS PRESENTED TO ME.

NAME OF APPLICANT

NAME OF CO-APPLICANT _____

EXHIBIT "C"
SPECIAL CONDITIONS

None.

TIME TABLE

ACTIVITY	DATE(S)
Contract Signing	December 12, 2017
Demolition	December 21, 2017
Construction Start	December 22, 2017
Anticipated Draws	After 50% construction completion After 100% construction completion 30 days after construction completion
End Construction	March 12, 2018

BUDGET

	Total Cost
Pre-Development	\$ 0.00
Acquisition	\$ 0.00
Demolition/Construction	\$61,740.00
Other Costs:	\$ 0.00
TOTAL PROJECT COSTS	\$61,740.00