



CONTRACT PRICING WORKSHEET
For MOTOR VEHICLES Only

Contract No.:

HT06-18

Date Prepared:

12/5/2018

This Worksheet is prepared by Contractor and given to End User. If a PO is issued, both documents MUST be faxed to H-GAC @ 713-993-4548. Therefore please type or print legibly.

Buying Agency:	Hidalgo County Pct3	Contractor:	Houston Freightliner
Contact Person:		Prepared By:	Adam Neuse
Phone:		Phone:	713-580-8148
Fax:		Fax:	713-676-1603
Email:		Email:	adam.neuse@strhouston.com

Product Code:	C3	Description:	2019 Freightliner 114SD TRA
---------------	----	--------------	-----------------------------

A. Product Item Base Unit Price Per Contractor's H-GAC Contract: 89830

B. Published Options - Itemize below - Attach additional sheet(s) if necessary - Include Option Code in description if applicable.
(Note: Published Options are options which were submitted and priced in Contractor's bid.)

Description	Cost	Description	Cost
Allison 4500 RDS Auto Trans	9884	Dual West Coast Heated Mirror W/ Remote	215
DA-F-20 20,000 LB Front Axle	2577	Jacobs Compression Brake	1915
20000 Front Suspension	1130	7/16x3-9/16x11-1/8" Frame 120KSI	654
Haulmaxx 46,000 LB Rear Suspension	3230	LH/RH 8" Bright Convex Fender Mirrors	104
260" Wheelbase	1159	Basic High Back Air Driver Seat	159
1/4" Inner Frame Reinforcement	717	Adjustable Steering Column	349
RH Understep Aftertreatment w Vert Stack	617	Front Sun Visor	140
Driver Controlled Differential Lock (Both Axles)	1091	LH/RH Electric Windows	164
DD13 450HP 1550 LB FT TQ	680		
Battery Disconnect Mtd LH Driver Seat	131	Special Stellar SI75174OR	37789
		Subtotal From Additional Sheet(s):	
		Subtotal B:	62705

C. Unpublished Options - Itemize below / attach additional sheet(s) if necessary.
(Note: Unpublished options are items which were not submitted and priced in Contractor's bid.)

Description	Cost	Description	Cost
MXL 18T Meritor Extended Lube Main Driveline	693	Meritor 16.5x8.62 Q+ Cast Spider Cam RR Brakes	343
Interior Convenience Package w CB Pro Vision	268	Subtotal From Additional Sheet(s):	
LH 90 Gallon Fuel Tanks	221	Subtotal C:	1525

Check: Total cost of Unpublished Options (C) cannot exceed 25% of the total of the Base Unit Price plus Published Options (A+B). For this transaction the percentage is: 1%

D. Total Cost Before Any Applicable Trade-In / Other Allowances / Discounts (A+B+C):

Quantity Ordered:	2	X Subtotal of A + B + C:	154060	=	Subtotal D:	308120	
E. H-GAC Order Processing Charge (Amount Per Current Policy):						Subtotal E:	1500

F. Trade-Ins / Special Discounts / Other Allowances / Freight / Installation / Miscellaneous Charges:

Description	Cost	Description	Cost
Discount	-773.02		
EW4 DD13 5 Year/250,000 Mile Warranty	3145		
Allison 4500 RDS Trans 5 Year Warranty	1122		
		Subtotal F:	3493.98

G. Total Purchase Price (D+E+F): 313113.98

Delivery Date:

Description:**Medium & Heavy Trucks & Truck Bodies**

Number:**HT06-18**

Effective Date:**06/01/2018 - 05/31/2020**

Contract Details:**A variety of bodies are available including flatbed/stake bodies, dump bodies, service/utility bodies, wrecker/carrier bodies, cement mixer bodies, water/lube tank bodies, landscape/brush bodies, van bodies, aerial lifts, cranes, and miscellaneous such as digger-derricks, curtain bodies.**

Category:**General Purpose, Emergency & Autonomous Vehicles**

Attachment-A

Vendor: Houston Freightliner, Inc.
Contract: HT06-18: Medium and Heavy Trucks & Truck Bodies

Applicable items are the catalog listed in the table below, as well as any pricing documents included in the awardee's bid response.

HGAC Product Code	MFGR	Model Descriptions	Price
C1	Freightliner	108SD, Conv. Cab, SBFA, SRA	\$70,380
C2	Freightliner	108SD, Conv. Cab, SBFA, TRA	\$78,960
C3	Freightliner	114SD, Conv. Cab, SFFA, TRA	\$89,830
C4	Freightliner	122SD, Conv Cab, SFFA, TRA	\$97,677
C5	Freightliner	M2-106, Conv. Cab, SBFA, SRA	\$61,652
C6	Freightliner	M2-106, Conv. Cab, SBFA, TRA	\$70,599
C7	Freightliner	M2-112, Conv. Cab, SBFA, TRA	\$84,543
C8	Freightliner	Cascadia CA113-DC, Conv. Cab Tractor, SBFA, TRA	\$93,748
C9	Freightliner	MT45 Stripped Chassis	\$48,967
C10	Freightliner	MT55 Stripped Chassis	\$51,375

- b. **Offeror** is encouraged to include options for non-equipment items that may be applicable to a sale, such as: Extended Warranties, Maintenance Agreements, Buy-back or Trade-In Agreements, Out-of-state Delivery Charges, Quantity or Special Discounts, Extended Training Classes, etc.

Published & Unpublished Options

- a. H-GAC Cooperative Purchasing Program (Program) contracts are awarded through a public competitive bid or proposal (RFP) process. Further to that process, Program policy considers an 'option' listed and priced in a bid or RFP Response: (1) To be a "**Published Option**"; (2) To be part of any awarded contract; and (3) To be available for purchase by Program members separately and independently from associated base line items. However, since Published Options may have not been subjected to the same scrutiny as the associated base line items, it cannot be concluded they were directly competed. Therefore, pursuant to Local Government Code 252.021(a), purchase of a published option costing more than \$50,000 shall not be allowed. Furthermore, **H-GAC** reserves the right at its sole discretion to disallow purchase of any Published Option through the Program if deemed contrary to the intent of the law.
- b. Any option that has not been listed and priced in the Response is considered to be an "**Unpublished Option**". Unpublished Options may be sold, but only in connection with the sale of a base Product Item, and only insofar as the total cost of all Unpublished Options remains below twenty five percent (25%) of the total summed cost of the base Product(s) plus any Published Options.
- c. No Published or Unpublished Option may be sold which essentially converts a Product such that it competes with a Product Item awarded to another contractor.

21. WARRANTIES, SALES & SERVICE

Unless otherwise addressed in Section B, the following requirements shall apply:

- a. Offeror must be a properly franchised dealer authorized to sell and service, including warranty service, all products offered and sold in response to the bid invitation or under any **H-GAC** contract.
- b. **Offeror** shall provide detailed Parts and Labor Warranty information with the Response. If **Offeror** submits a warranty with the Response which does not meet the minimum requirements herein, **Offeror** agrees by submission of a Response that such warranty shall be considered to be amended to meet those minimums.
- c. Warranties shall be manufacturer's standard and shall be inclusive of any other warranty requirements which may be stipulated elsewhere herein.
- d. Any warranties offered by a dealer shall be in addition to the manufacturer's standard warranty, and shall not be a substitute for such. **Offeror's** base price for any Product shall be inclusive of the standard warranty.
- e. Complete warranty information will be supplied to **End User** with each Product sold.
- a. Warranties need not apply to normal maintenance service or adjustments, or to any product reasonably shown to have been repaired or altered in any way so as to affect its stability, or to any product which has been subject to misuse, negligence, or accident.
- f. **Offeror/Contractor** is encouraged to offer extended warranties as an option.
- g. Neither **H-GAC** nor **End User** assume any warranty or liability on **Contractor's** behalf unless made or assumed in writing, initiated by **Contractor**, and agreed to in writing by **H-GAC** or the **End User** respectively.
- h. **Contractor** shall be responsible for the execution and effectiveness of all product warranty, and shall be the sole source for solution to problems arising from warranty claims. **Contractor** agrees to respond directly to correct warranty claims and to ensure reconciliation of warranty claims that have been assigned to a third party.

22. H-GAC ORDER PROCESSING CHARGE

H-GAC will levy an Order Processing Charge on **Contractor** for each sale done thru the **H-GAC** contract, with the exception of orders for motor vehicles. Any bid pricing submitted will be considered to include the Charge. The amount of the applicable charge shall be per the most current **H-GAC** schedule. For motor vehicle orders, the Processing Charge shall be levied on and paid by the **End User**.

23. PRE-PAYMENTS AND DISCOUNTS

- a. Progress, pre-payment and special discounts of any kind may be offered and detailed in the Response. Such discounts shall be clearly explained, but shall not be a determining factor in awarding contracts except in the case of tie offerings.
- b. Quantity discounts applicable to similar Products sold to one or more **End User** Departments may be offered. Determination as to product similarity shall rest solely with **Contractor**.
- c. For specific purchases, any proposed quantity, pre-payment or special discounts shall be clearly shown on the Contract Pricing Worksheet.

Prepared by:
 Tony Paniagua
 DOGGETT FREIGHTLINER OF
 SOUTH TEXAS, LLC
 3103 NORTH CAGE
 PHARR, TX 78577
 Phone:

S P E C I F I C A T I O N P R O P O S A L

Data Code	Description	Retail Price
Price Level		
PRL-17D	SD PRL-17D (EFF:11/14/17)	N/C
Data Version		
DRL-031	SPECPRO21 DATA RELEASE VER 031	N/C
Interior Convenience/Driver Retention Package		
055-004	INTERIOR CONVENIENCE PACKAGE WITH CB PROVISION	\$268.00
Vehicle Configuration		
001-177	114SD CONVENTIONAL CHASSIS	\$154,920.00
004-219	2019 MODEL YEAR SPECIFIED	STD
002-004	SET BACK AXLE - TRUCK	(\$2,442.00)
019-001	TRAILER TOWING PROVISION AT END OF FRAME FOR TRUCK	\$1,235.00
003-001	LH PRIMARY STEERING LOCATION	STD
General Service		
AA1-003	TRUCK/TRAILER CONFIGURATION	N/C
AA6-002	DOMICILED, USA (EXCLUDING CALIFORNIA AND CARB OPT-IN STATES)	N/C
A85-001	REFUSE SERVICE	N/C
A84-1SA	SANITATION BUSINESS SEGMENT	N/C
AA4-013	MOIST BULK COMMODITY	N/C
AA5-006	TERRAIN/DUTY: 10% (SOME) OF THE TIME, IN TRANSIT, IS SPENT ON NON-PAVED ROADS	N/C
AB1-008	MAXIMUM 8% EXPECTED GRADE	STD
AB5-003	MAINTAINED GRAVEL OR CRUSHED ROCK - MOST SEVERE IN-TRANSIT (BETWEEN SITES) ROAD SURFACE	N/C
995-1AE	FREIGHTLINER LEVEL II WARRANTY	N/C
A66-99D	EXPECTED FRONT AXLE(S) LOAD : 20000.0 lbs	



Prepared by:
 Tony Paniagua
 DOGGETT FREIGHTLINER OF
 SOUTH TEXAS, LLC
 3103 NORTH CAGE
 PHARR, TX 78577
 Phone:

Data Code	Description	Retail Price
A68-99D	EXPECTED REAR DRIVE AXLE(S) LOAD : 46000.0 lbs	
A63-99D	EXPECTED GROSS VEHICLE WEIGHT CAPACITY : 66000.0 lbs	
A70-99D	EXPECTED GROSS COMBINATION WEIGHT : 80000.0 lbs	
Truck Service		
AA3-010	ROLL OFF/ROLL ON BODY	N/C
A88-99D	EXPECTED TRUCK BODY LENGTH : 25.0 ft	
A89-99D	BRAKING-EXPECTED CAB TO BODY CLEARANCE : 15.0 in	
AF3-1EF	GALBREATH INC	N/C
Tractor Service		
AA2-005	FLATBED TRAILER	N/C
AH6-001	SINGLE (1) TRAILER	N/C
Engine		
101-2X9	DETROIT DD13 12.8L 450 HP @ 1625 RPM, 1900 GOV RPM, 1550 LB/FT @ 975 RPM	\$907.00
Electronic Parameters		
N	79A-078 78 MPH ROAD SPEED LIMIT	N/C
	79B-005 CRUISE CONTROL SPEED LIMIT 2 MPH LOWER THAN ROAD SPEED LIMIT	N/C
	79K-005 PTO MODE ENGINE RPM LIMIT - 900 RPM	N/C
	79M-002 PTO MODE BRAKE OVERRIDE - SERVICE BRAKE APPLIED OR PARK BRAKE NOT APPLIED	N/C
	79P-001 PTO RPM WITH CRUISE SET SWITCH - 600 RPM	N/C
	79Q-001 PTO RPM WITH CRUISE RESUME SWITCH - 600 RPM	N/C
	79W-001 ONE REMOTE PTO SPEED	N/C
	79X-005 PTO SPEED 1 SETTING - 900 RPM	N/C
	80D-001 SOFT CRUISE CONTROL ENABLED	N/C
	80G-001 PTO MINIMUM RPM - 600	N/C
	80L-003 ENABLE DPF REGEN ZONE 1 WITH AUTO ENGINE RPM ELEVATE FOR EXTENDED IDLE	N/C
Engine Equipment		
	99C-017 2016 ONBOARD DIAGNOSTICS/2010 EPA/CARB/FINAL GHG17 CONFIGURATION	STD
	99D-011 2008 CARB EMISSION CERTIFICATION - CLEAN IDLE (INCLUDES 6X4 INCH LABEL ON LOWER FORWARD CORNER OF DRIVER DOOR)	\$109.00
	13E-001 STANDARD OIL PAN	STD



Prepared by:
 Tony Paniagua
 DOGGETT FREIGHTLINER OF
 SOUTH TEXAS, LLC
 3103 NORTH CAGE
 PHARR, TX 78577
 Phone:

Data Code	Description	Retail Price
105-001	ENGINE MOUNTED OIL CHECK AND FILL	STD
* 133-004	ONE PIECE VALVE COVER	N/C
014-1B5	SIDE OF HOOD AIR INTAKE WITH DONALDSON HIGH CAPACITY AIR CLEANER WITH SAFETY ELEMENT, FIREWALL MOUNTED	STD
124-1D7	DR 12V 160 AMP 28-SI QUADRAMOUNT PAD ALTERNATOR WITH REMOTE BATTERY VOLT SENSE	STD
* 292-071	(3) ALLIANCE MODEL 1231XOE, GROUP 31, 12 VOLT MAINTENANCE FREE 3375 CCA THREADEDSTUD BATTERIES	N/C
290-017	BATTERY BOX FRAME MOUNTED	STD
281-001	STANDARD BATTERY JUMPERS	STD
282-001	SINGLE BATTERY BOX FRAME MOUNTED LH SIDE UNDER CAB	\$18.00
291-017	WIRE GROUND RETURN FOR BATTERY CABLES WITH ADDITIONAL FRAME GROUND RETURN	STD
289-001	NON-POLISHED BATTERY BOX COVER	STD
87P-001	CAB AUXILIARY POWER CABLE	\$66.00
293-058	POSITIVE LOAD DISCONNECT WITH CAB MOUNTED CONTROL SWITCH MOUNTED OUTBOARD DRIVER SEAT	\$230.00
295-029	POSITIVE AND NEGATIVE POSTS FOR JUMPSTART LOCATED ON FRAME NEXT TO STARTER	\$97.00
107-044	BW MODEL BA-921 19.0 CFM SINGLE CYLINDER AIR COMPRESSOR WITH SAFETY VALVE	STD
152-041	ELECTRONIC ENGINE INTEGRAL SHUTDOWN PROTECTION SYSTEM	STD
128-002	JACOBS COMPRESSION BRAKE	STD
016-1C2	RH OUTBOARD UNDER STEP MOUNTED HORIZONTAL AFTERTREATMENT SYSTEM ASSEMBLY WITH RH B-PILLAR MOUNTED VERTICAL TAILPIPE	\$823.00
28F-002	ENGINE AFTERTREATMENT DEVICE, AUTOMATIC OVER THE ROAD REGENERATION AND DASH MOUNTED REGENERATION REQUEST SWITCH	STD
239-026	10 FOOT 06 INCH (126 INCH+0/-5.9 INCH) EXHAUST SYSTEM HEIGHT	(\$4.00)
237-1CR	RH CURVED VERTICAL TAILPIPE B-PILLAR MOUNTED ROUTED FROM STEP	N/C
23U-002	13 GALLON DIESEL EXHAUST FLUID TANK	STD
30N-003	100 PERCENT DIESEL EXHAUST FLUID FILL	STD



Prepared by:
 Tony Paniagua
 DOGGETT FREIGHTLINER OF
 SOUTH TEXAS, LLC
 3103 NORTH CAGE
 PHARR, TX 78577
 Phone:

Data Code	Description	Retail Price
23Y-001	STANDARD DIESEL EXHAUST FLUID PUMP MOUNTING	STD
43X-002	LH MEDIUM DUTY STANDARD DIESEL EXHAUST FLUID TANK LOCATION	STD
43Y-001	STANDARD DIESEL EXHAUST FLUID TANK CAP	STD
242-011	ALUMINUM AFTERTREATMENT DEVICE/MUFFLER/TAILOPIPE SHIELD(S)	N/C
273-036	BORG WARNER (KYSOR) REAR AIR ON/OFF ENGINE FAN CLUTCH	STD
276-001	AUTOMATIC FAN CONTROL WITHOUT DASH SWITCH, NON ENGINE MOUNTED	STD
110-068	DDC SUPPLIED ENGINE MOUNTED FUEL FILTER/FUEL WATER SEPARATOR WITH WATER-IN-FUEL INDICATOR	STD
118-001	FULL FLOW OIL FILTER	STD
266-057	1500 SQUARE INCH ALUMINUM RADIATOR	STD
* 267-003	RADIATOR MOUNTED SURGE TANK	(\$64.00)
103-039	ANTIFREEZE TO -34F, OAT (NITRITE AND SILICATE FREE) EXTENDED LIFE COOLANT	STD
171-007	GATES BLUE STRIPE COOLANT HOSES OR EQUIVALENT	STD
172-001	CONSTANT TENSION HOSE CLAMPS FOR COOLANT HOSES	STD
270-023	HDEP FIXED RATIO COOLANT PUMP AND RADIATOR DRAIN VALVE	STD
155-075	mitsubishi 12V MOD 3.175-DP60 STARTER WITH INTEGRATED MAGNETIC SWITCH	STD

Transmission

342-1M3	ALLISON 4500 RDS AUTOMATIC TRANSMISSION WITH PTO PROVISION	\$13,178.00
---------	--	-------------

Transmission Equipment

343-325	ALLISON VOCATIONAL PACKAGE 180 - AVAILABLE ON 3000/4000 PRODUCT FAMILIES WITH VOCATIONAL MODEL RDS	N/C
84B-013	ALLISON VOCATIONAL RATING FOR REFUSE APPLICATIONS AVAILABLE WITH ALL PRODUCT FAMILIES	N/C
84C-023	PRIMARY MODE GEARS, LOWEST GEAR 1, START GEAR 1, HIGHEST GEAR 6, AVAILABLE FOR 3000/4000 PRODUCT FAMILIES ONLY	STD
84D-023	SECONDARY MODE GEARS, LOWEST GEAR 1, START GEAR 1, HIGHEST GEAR 6, AVAILABLE FOR 3000/4000 PRODUCT FAMILIES ONLY	STD

Prepared by:
 Tony Paniagua
 DOGGETT FREIGHTLINER OF
 SOUTH TEXAS, LLC
 3103 NORTH CAGE
 PHARR, TX 78577
 Phone:

Data Code	Description	Retail Price
84E-000	PRIMARY SHIFT SCHEDULE RECOMMENDED BY DTNA AND ALLISON, THIS DEFINED BY ENGINE AND VOCATIONAL USAGE	STD
84F-000	SECONDARY SHIFT SCHEDULE RECOMMENDED BY DTNA AND ALLISON, THIS DEFINED BY ENGINE AND VOCATIONAL USAGE	STD
84G-000	PRIMARY SHIFT SPEED RECOMMENDED BY DTNA AND ALLISON, THIS DEFINED BY ENGINE AND VOCATIONAL USAGE	STD
N 84H-007	1700 RPM SECONDARY MODE SHIFT SPEED	N/C
84L-000	LOAD BASED SHIFT SCHEDULE AND VEHICLE ACCELERATION CONTROL RECOMMENDED BY DTNA AND ALLISON, THIS DEFINED VOCATIONAL USAGE	STD
84N-000	NEUTRAL AT STOP - DISABLED, FUELSENSE - DISABLED	STD
84U-000	DRIVER SWITCH INPUT - DEFAULT - NO SWITCHES	STD
84V-001	DIRECTION CHANGE ENABLED WITH MULTIPLEXED SERVICE BRAKES - ALLISON 5TH GEN TRANSMISSIONS	STD
362-035	CUSTOMER INSTALLED CHELSEA 277 SERIES PTO	N/C
363-001	PTO MOUNTING, LH SIDE OF MAIN TRANSMISSION	N/C
341-018	MAGNETIC PLUGS, ENGINE DRAIN, TRANSMISSION DRAIN, AXLE(S) FILL AND DRAIN	STD
345-003	PUSH BUTTON ELECTRONIC SHIFT CONTROL, DASH MOUNTED	STD
97G-004	TRANSMISSION PROGNOSTICS - ENABLED 2013	STD
370-011	WATER TO OIL TRANSMISSION COOLER, FRAME MOUNTED	STD
346-003	TRANSMISSION OIL CHECK AND FILL WITH ELECTRONIC OIL LEVEL CHECK	STD
35T-001	SYNTHETIC TRANSMISSION FLUID (TES-295 COMPLIANT)	STD

Front Axle and Equipment

400-1BB	DETROIT DA-F-20.0-5 20,000# FL1 71.0 KPI/3.74 DROP SINGLE FRONT AXLE	\$3,436.00
402-030	MERITOR 16.5X6 Q+ CAST SPIDER CAM FRONT BRAKES, DOUBLE ANCHOR, FABRICATED SHOES	N/C
403-002	NON-ASBESTOS FRONT BRAKE LINING	STD
419-023	CONMET CAST IRON FRONT BRAKE DRUMS	STD

Prepared by:
 Tony Paniagua
 DOGGETT FREIGHTLINER OF
 SOUTH TEXAS, LLC
 3103 NORTH CAGE
 PHARR, TX 78577
 Phone:

Data Code	Description	Retail Price
409-006	FRONT OIL SEALS	STD
408-001	VENTED FRONT HUB CAPS WITH WINDOW, CENTER AND SIDE PLUGS - OIL	STD
416-022	STANDARD SPINDLE NUTS FOR ALL AXLES	STD
405-002	MERITOR AUTOMATIC FRONT SLACK ADJUSTERS	STD
406-001	STANDARD KING PIN BUSHINGS	STD
536-055	TRW THP-60 POWER STEERING WITH RCH45 AUXILIARY GEAR	N/C
539-003	POWER STEERING PUMP	STD
534-003	4 QUART POWER STEERING RESERVOIR	N/C
533-001	OIL/AIR POWER STEERING COOLER	N/C
40T-001	ORGANIC SAE 80/90 FRONT AXLE LUBE	STD

Front Suspension

620-025	20,000# TAPERLEAF FRONT SUSPENSION	\$1,507.00
619-005	MAINTENANCE FREE RUBBER BUSHINGS - FRONT SUSPENSION	STD
410-001	FRONT SHOCK ABSORBERS	STD

Rear Axle and Equipment

420-103	RT-46-160 46,000# R-SERIES TANDEM REAR AXLE	\$3,737.00
421-373	3.73 REAR AXLE RATIO	\$147.00
424-001	IRON REAR AXLE CARRIER WITH STANDARD AXLE HOUSING	STD
386-075	MXL 18T MERITOR EXTENDED LUBE MAIN DRIVELINE WITH HALF ROUND YOKES	\$693.00
388-073	MXL 17T MERITOR EXTENDED LUBE INTERAXLE DRIVELINE WITH HALF ROUND YOKES	STD
452-006	DRIVER CONTROLLED TRACTION DIFFERENTIAL - BOTH TANDEM REAR AXLES	\$1,244.00
878-023	(1) INTERAXLE LOCK VALVE, (1) DRIVER CONTROLLED DIFFERENTIAL LOCK FORWARD- REAR AND REAR-REAR AXLE VALVE	N/C
87A-002	BUZZER AND BLINKING LAMP WITH EACH INTERAXLE LOCK SWITCH, INTERAXLE UNLOCK DEFAULT WITH IGNITION OFF	N/C
87B-005	BUZZER AND BLINKING LAMP WITH EACH MODE SWITCH, DIFFERENTIAL UNLOCK WITH IGNITION OFF, ACTIVE <5 MPH	N/C
423-019	MERITOR 16.5X8.62 Q+ CAST SPIDER CAM REAR BRAKES, DOUBLE ANCHOR, FABRICATED SHOES	\$343.00
433-002	NON-ASBESTOS REAR BRAKE LINING	STD

Prepared by:
 Tony Paniagua
 DOGGETT FREIGHTLINER OF
 SOUTH TEXAS, LLC
 3103 NORTH CAGE
 PHARR, TX 78577
 Phone:

Data Code	Description	Retail Price
434-003	STANDARD BRAKE CHAMBER LOCATION	STD
451-023	CONMET CAST IRON REAR BRAKE DRUMS	STD
440-006	REAR OIL SEALS	STD
426-1B3	BENDIX EVERSURE LONGSTROKE 2-DRIVE AXLES SPRING PARKING CHAMBERS	\$44.00
428-003	HALDEX AUTOMATIC REAR SLACK ADJUSTERS	\$110.00
41T-001	ORGANIC SAE 80/90 REAR AXLE LUBE	STD
42T-001	STANDARD REAR AXLE BREATHER(S)	STD
Rear Suspension		
622-1E7	HENDRICKSON HAULMAAX @46,000#REAR SUSPENSION	\$4,221.00
621-1AP	HENDRICKSON HAULMAAX/ULTIMAAX - 10.50" RIDE HEIGHT	N/C
624-009	54 INCH AXLE SPACING	N/C
628-010	HENDRICKSON HN, HAULMAAX AND ULTIMAAX SERIES STEEL BEAMS WITH BAR PIN	N/C
623-006	FORE/AFT AND TRANSVERSE CONTROL RODS	N/C
439-002	REAR SHOCK ABSORBERS - TWO AXLES (TANDEM)	\$224.00
Brake System		
490-100	WABCO 4S/4M ABS	STD
871-001	REINFORCED NYLON, FABRIC BRAID AND WIRE BRAID CHASSIS AIR LINES	STD
904-001	FIBER BRAID PARKING BRAKE HOSE	STD
412-001	STANDARD BRAKE SYSTEM VALVES	STD
46D-002	STANDARD AIR SYSTEM PRESSURE PROTECTION SYSTEM	STD
413-002	STD U.S. FRONT BRAKE VALVE	STD
432-003	RELAY VALVE WITH 5-8 PSI CRACK PRESSURE, NO REAR PROPORTIONING VALVE	STD
N 480-083	WABCO SS-1200 PLUS AIR DRYER WITH INTEGRAL AIR GOVERNOR AND HEATER	STD
483-004	WABCO OIL COALESCING FILTER FOR AIR DRYER	\$25.00
479-003	AIR DRYER MOUNTED INBOARD ON LH RAIL	N/C
460-008	STEEL AIR BRAKE RESERVOIRS MOUNTED INSIDE RAIL	\$4.00
607-001	CLEAR FRAME RAILS FROM BACK OF CAB TO FRONT REAR SUSPENSION BRACKET, BOTH RAILS OUTBOARD	\$63.00
477-001	PULL CABLE ON WET TANK, PETCOCK DRAIN VALVES ON ALL OTHER AIR TANKS	STD



Prepared by:
 Tony Paniagua
 DOGGETT FREIGHTLINER OF
 SOUTH TEXAS, LLC
 3103 NORTH CAGE
 PHARR, TX 78577
 Phone:

Data Code	Description	Retail Price
Trailer Connections		
914-001	AIR CONNECTIONS TO END OF FRAME WITH GLAD HANDS FOR TRUCK AND NO DUST COVERS	N/C
296-010	PRIMARY CONNECTOR/RECEPTACLE WIRED FOR SEPARATE STOP/TURN, ABS CENTER PIN POWERED THROUGH IGNITION	N/C
297-001	SAE J560 7-WAY PRIMARY TRAILER CABLE RECEPTACLE MOUNTED END OF FRAME	N/C
335-004	UPGRADED CHASSIS MULTIPLEXING UNIT	STD
Wheelbase & Frame		
545-660	6600MM (260 INCH) WHEELBASE	N/C
546-102	7/16X3-9/16X11-1/8 INCH STEEL FRAME (11.11MMX282.6MM/0.437X11.13 INCH) 120KSI	\$1,328.00
547-001	1/4 INCH (6.35MM) C-CHANNEL INNER FRAME REINFORCEMENT	\$1,452.00
552-030	1600MM (63 INCH) REAR FRAME OVERHANG	STD
55W-006	FRAME OVERHANG RANGE: 61 INCH TO 70 INCH	N/C
AC8-99D	CALC'D BACK OF CAB TO REAR SUSP C/L (CA) : 194.29 in	
AE8-99D	CALCULATED EFFECTIVE BACK OF CAB TO REAR SUSPENSION C/L (CA) : 179.29 in	
AE4-99D	CALC'D FRAME LENGTH - OVERALL : 352.95	
AM6-99D	CALC'D SPACE AVAILABLE FOR DECKPLATE : 194.45 in	
FSS-0LH	CALCULATED FRAME SPACE LH SIDE : 77.08 in	N/C
FSS-0RH	CALCULATED FRAME SPACE RH SIDE : 248.03 in	N/C
553-001	SQUARE END OF FRAME	STD
550-001	FRONT CLOSING CROSSMEMBER	STD
559-001	STANDARD WEIGHT ENGINE CROSSMEMBER	STD
562-001	STANDARD MIDSHIP #1 CROSSMEMBER(S)	STD
572-001	STANDARD REARMOST CROSSMEMBER	STD
565-001	STANDARD SUSPENSION CROSSMEMBER	STD
Chassis Equipment		
556-1E7	14 INCH PAINTED STEEL SEVERE DUTY BUMPER	\$484.00
558-033	REMOVABLE FRONT TOW HOOKS STORED ON THE CHASSIS FRAME	\$175.00
574-001	BUMPER MOUNTING FOR SINGLE LICENSE PLATE	STD



Prepared by:
 Tony Paniagua
 DOGGETT FREIGHTLINER OF
 SOUTH TEXAS, LLC
 3103 NORTH CAGE
 PHARR, TX 78577
 Phone:

Data Code	Description	Retail Price
* 586-024	FENDER AND FRONT OF HOOD MOUNTED FRONT M UDFLAPS	N/C
551-001	HUCK-SPIN ROUND COLLAR CHASSIS FASTENERS SUSPENSIONS ONLY	(\$121.00)
Fuel Tanks		
204-155	90 GALLON/340 LITER ALUMINUM FUEL TANK - LH	\$221.00
218-006	25 INCH DIAMETER FUEL TANK(S)	STD
215-005	PLAIN ALUMINUM/PAINTED STEEL FUEL/HYDRAULIC TANK(S) WITH PAINTED BANDS	STD
212-007	FUEL TANK(S) FORWARD	STD
664-001	PLAIN STEP FINISH	STD
205-001	FUEL TANK CAP(S)	STD
216-020	EQUIFLO INBOARD FUEL SYSTEM	STD
11F-998	NO NATURAL GAS VEHICLE FUEL TANK VENT LINE/STACK	STD
202-016	HIGH TEMPERATURE REINFORCED NYLON FUEL LINE	STD
221-001	FUEL COOLER	\$134.00
Tires		
093-1PB	CONTINENTAL CITY SERVICE HA3 315/80R22.5 20 PLY RADIAL FRONT TIRES	\$560.00
* 094-2C7	HANKOOK DL11 11R22.5 16 PLY RADIAL REAR TIRES	(\$1,216.00)
Hubs		
418-060	CONMET PRESET PLUS PREMIUM IRON FRONT HUBS	STD
450-060	CONMET PRESET PLUS PREMIUM IRON REAR HUBS	STD
Wheels		
502-433	ACCURIDE 29039 22.5X9.00 10-HUB PILOT 5.25 INSET 5-HAND STEEL DISC FRONT WHEELS	\$182.00
505-524	MAXION WHEELS 90541 22.5X8.25 10-HUB PILOT 2-HAND STEEL DISC REAR WHEELS	(\$240.00)
Cab Exterior		
829-1A2	114 INCH BBC FLAT ROOF ALUMINUM CONVENTIONAL CAB	STD
650-008	AIR CAB MOUNTING	STD
648-002	NONREMOVABLE BUGSCREEN MOUNTED BEHIND GRILLE	STD



Prepared by:
 Tony Paniagua
 DOGGETT FREIGHTLINER OF
 SOUTH TEXAS, LLC
 3103 NORTH CAGE
 PHARR, TX 78577
 Phone:

Data Code	Description	Retail Price
667-004	FRONT FENDERS SET-BACK AXLE	N/C
678-001	LH AND RH GRAB HANDLES	STD
645-002	BRIGHT FINISH RADIATOR SHELL/HOOD BEZEL	\$221.00
646-042	STATIONARY BLACK GRILLE WITH BRIGHT ACCENTS	\$66.00
65X-003	CHROME HOOD MOUNTED AIR INTAKE GRILLE	\$15.00
644-004	FIBERGLASS HOOD	STD
727-1AF	SINGLE 14 INCH ROUND HADLEY AIR HORN UNDER LH DECK	(\$20.00)
726-002	DUAL ELECTRIC HORNS	\$3.00
728-001	SINGLE HORN SHIELD	STD
657-001	DOOR LOCKS AND IGNITION SWITCH KEYED THE SAME	STD
575-001	REAR LICENSE PLATE MOUNT END OF FRAME	STD
312-067	HALOGEN COMPOSITE HEADLAMPS WITH BRIGHT BEZELS	N/C
302-047	LED AERODYNAMIC MARKER LIGHTS	\$34.00
294-001	INTEGRAL STOP/TAIL/BACKUP LIGHTS	STD
300-015	STANDARD FRONT TURN SIGNAL LAMPS	STD
744-1BC	DUAL WEST COAST BRIGHT FINISH HEATED MIRRORS WITH LH AND RH REMOTE	\$286.00
797-001	DOOR MOUNTED MIRRORS	STD
796-001	102 INCH EQUIPMENT WIDTH	STD
743-204	LH AND RH 8 INCH BRIGHT FINISH CONVEX MIRRORS MOUNTED UNDER PRIMARY MIRRORS	N/C
74B-080	RH AND LH 8 INCH STAINLESS STEEL FENDER MOUNTED CONVEX MIRRORS WITH TRIPOD BRACKETS	\$201.00
729-001	STANDARD SIDE/REAR REFLECTORS	STD
677-053	RH AFTERTREATMENT SYSTEM CAB ACCESS WITH STEEL SHIELDING	STD
764-010	COMPOSITE EXTERIOR SUN VISOR	\$247.00
768-043	63X14 INCH TINTED REAR WINDOW	STD
661-004	TINTED DOOR GLASS LH AND RH WITH TINTED OPERATING WING WINDOWS	STD
654-027	RH AND LH ELECTRIC POWERED WINDOWS, PASSENGER SWITCHES ON DOOR(S)	\$218.00
663-013	TINTED WINDSHIELD	STD
659-019	2 GALLON WINDSHIELD WASHER RESERVOIR WITHOUT FLUID LEVEL INDICATOR, FRAME MOUNTED	(\$74.00)



Prepared by:
 Tony Paniagua
 DOGGETT FREIGHTLINER OF
 SOUTH TEXAS, LLC
 3103 NORTH CAGE
 PHARR, TX 78577
 Phone:

Data Code	Description	Retail Price
Cab Interior		
707-1AK	OPAL GRAY VINYL INTERIOR	STD
706-026	MOLDED PLASTIC DOOR PANEL WITHOUT VINYL INSERT WITH ALUMINUM KICKPLATE LOWER DOOR	\$25.00
708-026	MOLDED PLASTIC DOOR PANEL WITHOUT VINYL INSERT WITH ALUMINUM KICKPLATE LOWER DOOR	\$25.00
772-006	BLACK MATS WITH SINGLE INSULATION	STD
785-001	DASH MOUNTED ASH TRAYS AND LIGHTER	\$12.00
691-008	FORWARD ROOF MOUNTED CONSOLE WITH UPPER STORAGE COMPARTMENTS WITHOUT NETTING	STD
742-007	(2) CUP HOLDERS LH AND RH DASH	STD
680-007	GRAY/CHARCOAL WING DASH	STD
720-003	5 LB. FIRE EXTINGUISHER	\$60.00
700-002	HEATER, DEFROSTER AND AIR CONDITIONER	STD
701-001	STANDARD HVAC DUCTING	STD
703-005	MAIN HVAC CONTROLS WITH RECIRCULATION SWITCH	STD
170-015	STANDARD HEATER PLUMBING	STD
130-033	DENSO HEAVY DUTY AIR CONDITIONER COMPRESSOR	STD
702-002	BINARY CONTROL, R-134A	STD
739-033	STANDARD INSULATION	STD
285-013	SOLID-STATE CIRCUIT PROTECTION AND FUSES	STD
280-007	12V NEGATIVE GROUND ELECTRICAL SYSTEM	STD
324-011	DOMED DOOR ACTIVATED LH AND RH, DUAL READING LIGHTS, FORWARD CAB ROOF	N/C
655-005	LH AND RH ELECTRIC DOOR LOCKS	\$99.00
284-023	(1) 12 VOLT POWER SUPPLY IN DASH	STD
722-012	TRIANGULAR REFLECTORS WITH FLARE HOLDER (FLARES NOT INCLUDED)	\$37.00
756-1J3	BASIC HIGH BACK AIR SUSPENSION DRIVER SEAT WITH MECHANICAL LUMBAR AND INTEGRATED CUSHION EXTENSION	\$225.00
760-1DC	BASIC HIGH BACK NON SUSPENSION PASSENGER SEAT	STD
759-007	DUAL DRIVER SEAT ARMRESTS, NO PASSENGER SEAT ARMRESTS	\$69.00
711-004	LH AND RH INTEGRAL DOOR PANEL ARMRESTS	STD



Prepared by:
 Tony Paniagua
 DOGGETT FREIGHTLINER OF
 SOUTH TEXAS, LLC
 3103 NORTH CAGE
 PHARR, TX 78577
 Phone:

Data Code	Description	Retail Price
758-014	BLACK CORDURA PLUS CLOTH DRIVER SEAT COVER	\$2.00
761-014	BLACK CORDURA PLUS CLOTH PASSENGER SEAT COVER	\$2.00
763-101	BLACK SEAT BELTS	STD
532-002	ADJUSTABLE TILT AND TELESCOPING STEERING COLUMN	\$478.00
540-015	4-SPOKE 18 INCH (450MM) STEERING WHEEL	STD
765-002	DRIVER AND PASSENGER INTERIOR SUN VISORS	STD

Instruments & Controls

732-003	WOODGRAIN DRIVER INSTRUMENT PANEL	N/C
734-003	WOODGRAIN CENTER INSTRUMENT PANEL	N/C
870-001	BLACK GAUGE BEZELS	STD
486-001	LOW AIR PRESSURE INDICATOR LIGHT AND AUDIBLE ALARM	STD
840-002	2 INCH PRIMARY AND SECONDARY AIR PRESSURE GAUGES	STD
198-025	INTAKE MOUNTED AIR RESTRICTION INDICATOR WITHOUT GRADUATIONS	STD
721-001	97 DB BACKUP ALARM	\$47.00
149-017	ELECTRONIC CRUISE CONTROL WITH SWITCHES ON AUXILIARY GAUGE PANEL (B DASH PANEL)	STD
156-007	KEY OPERATED IGNITION SWITCH AND INTEGRAL START POSITION; 4 POSITION OFF/RUN/START/ACCESSORY	STD
811-042	ICU3S, 132X48 DISPLAY WITH DIAGNOSTICS, 28 LED WARNING LAMPS AND DATA LINKED	STD
160-038	HEAVY DUTY ONBOARD DIAGNOSTICS INTERFACE CONNECTOR LOCATED BELOW LH DASH	STD
844-001	2 INCH ELECTRIC FUEL GAUGE	STD
845-011	FUEL FILTER RESTRICTION INDICATOR	STD
148-085	EMISSIONS LIMITED IDLE ADJUST	STD
856-001	ELECTRICAL ENGINE COOLANT TEMPERATURE GAUGE	STD
864-001	2 INCH TRANSMISSION OIL TEMPERATURE GAUGE	STD
830-017	ENGINE AND TRIP HOUR METERS INTEGRAL WITHIN DRIVER DISPLAY	STD
372-051	CUSTOMER FURNISHED AND INSTALLED PTO CONTROLS	N/C
852-002	ELECTRIC ENGINE OIL PRESSURE GAUGE	STD



Prepared by:
 Tony Paniagua
 DOGGETT FREIGHTLINER OF
 SOUTH TEXAS, LLC
 3103 NORTH CAGE
 PHARR, TX 78577
 Phone:

Data Code	Description	Retail Price
679-001	OVERHEAD INSTRUMENT PANEL	N/C
748-006	POWER AND GROUND WIRING PROVISION OVERHEAD	N/C
749-016	CB WIRING ONLY TO ROOF/OVERHEAD CONSOLE; NO MOUNTING PROVISION	N/C
810-027	ELECTRONIC MPH SPEEDOMETER WITH SECONDARY KPH SCALE, WITHOUT ODOMETER	STD
817-001	STANDARD VEHICLE SPEED SENSOR	STD
812-001	ELECTRONIC 3000 RPM TACHOMETER	STD
813-1B4	VT-HU CONNECTIVITY PLATFORM HARDWARE	STD
8D1-002	2 YEARS DETROIT CONNECT BASE PACKAGE (VIRTUAL TECHNICIAN, DETROIT CONNECT PORTAL ACCESS) FOR VT-HU CONNECTIVITY PLATFORM	STD
162-002	IGNITION SWITCH CONTROLLED ENGINE STOP	STD
482-001	BW TRACTOR PROTECTION VALVE	N/C
883-001	TRAILER HAND CONTROL BRAKE VALVE	N/C
836-015	DIGITAL VOLTAGE DISPLAY INTEGRAL WITH DRIVER DISPLAY	STD
660-008	SINGLE ELECTRIC WINDSHIELD WIPER MOTOR WITH DELAY	STD
304-001	MARKER LIGHT SWITCH INTEGRAL WITH HEADLIGHT SWITCH	STD
882-004	TWO VALVE PARKING BRAKE SYSTEM WITH WARNING INDICATOR	N/C
299-013	SELF CANCELING TURN SIGNAL SWITCH WITH DIMMER, WASHER/WIPER AND HAZARD IN HANDLE	STD
298-039	INTEGRAL ELECTRONIC TURN SIGNAL FLASHER WITH HAZARD LAMPS OVERRIDING STOP LAMPS	STD
Design		
065-000	PAINT: ONE SOLID COLOR	STD
Color		
980-5F6	CAB COLOR A: L0006EB WHITE ELITE BC	STD
986-020	BLACK, HIGH SOLIDS POLYURETHANE CHASSIS PAINT	STD
962-972	POWDER WHITE (N0006EA) FRONT WHEELS/RIMS (PKWHT21, TKWHT21, W, TW)	STD
966-972	POWDER WHITE (N0006EA) REAR WHEELS/RIMS (PKWHT21, TKWHT21, W, TW)	STD
964-020	STANDARD BLACK BUMPER PAINT	STD



Prepared by:
 Tony Paniagua
 DOGGETT FREIGHTLINER OF
 SOUTH TEXAS, LLC
 3103 NORTH CAGE
 PHARR, TX 78577
 Phone:

Data Code	Description	Retail Price
976-995	SUNVISOR PAINTED SAME AS CAB COLOR A	N/C
963-003	STANDARD E COAT/UNDERCOATING	STD

Certification / Compliance

996-001	U.S. FMVSS CERTIFICATION, EXCEPT SALES CABS AND GLIDER KITS	STD
---------	---	-----

Secondary Factory Options

998-001	CORPORATE PDI CENTER IN-SERVICE ONLY	N/C
---------	--------------------------------------	-----

TOTAL VEHICLE SUMMARY

Adjusted List Price

Adjusted List Price ** \$190,376.00

ITEMS NOT INCLUDED IN ADJUSTED LIST PRICE

Other Factory Charges

PMU-017	2016 OBD/2010 EPA/CARB/GHG17 ESCALATOR	\$350.00
RD1-002	2 YEARS DETROIT CONNECT BASE PACKAGE (VIRTUAL TECHNICIAN, DETROIT CONNECT PORTAL ACCESS)	STD
P73-2FT	STANDARD DESTINATION CHARGE	\$2,100.00

(**) Prices shown do not include taxes, fees, etc... "Net Equipment Selling Price" is located on the Quotation Details Proposal Report.





STELLAR® CABLE HOIST TECHNICAL SPECIFICATION GUIDE

SI75

75,000 Capacity Cable Hoist



Our People. Our Products.

STELLAR® CABLE HOIST TECHNICAL SPECIFICATION GUIDE

■ STANDARD EQUIPMENT

Hoist rated capacity	.75,000 lbs.
Main frame	.8" x 4" x 1/2" A500 C tubing
Sub frame	.4" x 2" x 1/4" A500 C tubing
Front stop	.1-1/2" plate
Container lock	.Automatic spring loaded
Lift cylinder shaft	.2-1/2" plate
Rear hinge shaft	.3" solid steel
Cable	.1" (6 x 37 EXIWRC)
Cable sheaves	.10" O.D. bronze-bushed sheave
Cable anchor	.4 cable clamps
Cable end	.Steel casting
Rear hold down	.1" plate located for std. containers
Middle hold down	.3/4" plate
Lift cylinders	.6" x 72" D.A.
Reeving cylinders	.7" x 80" D.A.
Direct mount pump	.Gear types 35 GPM @ 1500 RPM
Operating pressure	.1850 PSI
Hydraulic valve	.2 spool 45 GPM safety bypass
Hydraulic reservoir	.60 gal. 25 micron filter & screen filter
Outside rollers	.4" O.D. with bronze bearing
Inside rollers	.6" O.D. hardened roller & pins
Working points	.Greaseable
Safety stand	.Factory installed
I.C.C. Bumper	.Folding, mounting lugs factory installed
Rear bumper	.Pre-drilled bolt mount - sealed beam backup, clearance and tail lights
Hoist up	.30 sec. approx.
Hoist down	.15 sec. approx.
Cable in	.46 sec. approx
Cable out	.37 sec. approx.
Container length	.18' - 22'
Approximate weight	.6100 lbs.
Hydraulic valve	.3 spool 45 GPM safety bypass
Cable end	.Steel casting, knuckle-type
Rear flange roller	.8" O.D. hardened w/2 1/2" c-1045
Rear center sheave	.8" O.D. hardened

■ OPTIONAL EQUIPMENT

Lift Cylinder- T Models	.6" x 72" (5.5 x 4.5" x 3.5" x 125") Telescopic Cylinders
Inside controls	.Direct connect, cable or pneumatic
Remote mount hydraulic pump	.Gear type 35 GPM @ 1500 RPM
Auxiliary fold down front stops	.For short containers
Full fenders	.Tandem or tri-axle, 12 ga. steel or poly
Tarp rack / tool box combination	.20" x 16" x 48"
4 Spool valve	
"Drop-in" Stops	
Cab Guard	
Drop-center cylinder mounting shaft	
PTO air operated with signal light	
Hoist-up alarm	
Single - acting hydraulic line to rear*	
Double - acting hydraulic line to rear*	
Double - acting hydraulic line to side*	

*Note: This requires the 3 spool valve option or selector valve

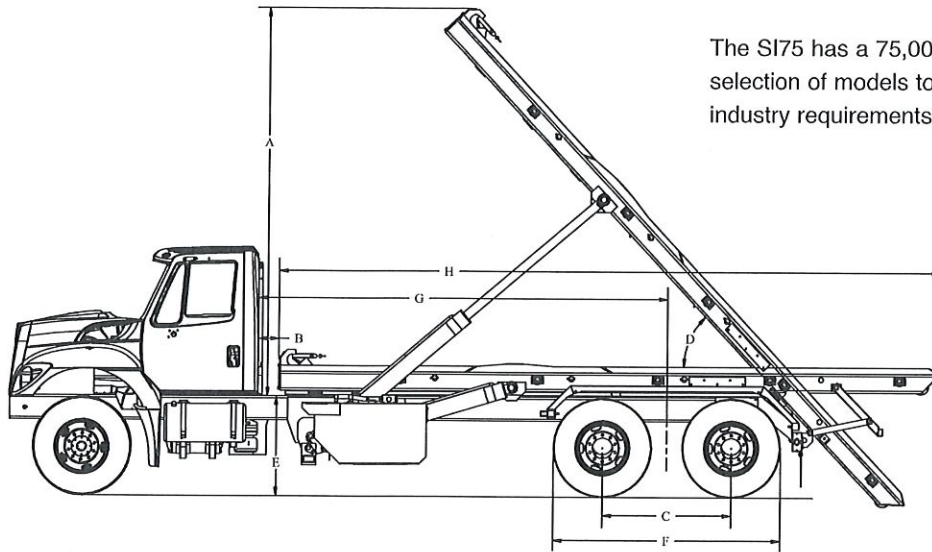

The SI75 has a 75,000 lb. capacity, and a wide selection of models to accommodate different industry requirements.

■ **OUTSIDE RAIL SERIES**

Model	A	B	C	D	E	F	G	H
SI75-174OR	166"	5-6"	51-55"	47°	43" Max	96" Max	174"	281"
SI75-182OR	172"	5-6"	51-55"	47°	43" Max	96" Max	182"	289"
SI75-194OR	178"	5-6"	51-55"	47°	43" Max	96" Max	194"	301"

■ **OUTSIDE RAIL SERIES W/ EXTENDABLE TAIL (TAIL EXTENSION ADDS 80" AT FULL EXTENSION)**

Model	A	B	C	D	E	F	G	H
SI75-174ORX	166"	5-6"	51-55"	47°	48" Max	96" Max	174"	237"
SI75-182ORX	174"	5-6"	51-55"	47°	48" Max	96" Max	182"	245"
SI75-194ORX	178"	5-6"	51-55"	48°	48" Max	ORT Specs	194"	257"

■ **INSIDE/OUTSIDE RAIL SERIES**

Model	A	B	C	D	E	F	G	H
SI75-174IO	166"	5-6"	51-55"	47°	43" Max	96" Max	174"	281"
SI75-182IO	172"	5-6"	51-55"	47°	43" Max	96" Max	182"	289"
SI75-194IO	178"	5-6"	51-55"	47°	43" Max	96" Max	194"	301"

■ **INSIDE/OUTSIDE RAIL SERIES W/ EXTENDABLE TAIL (TAIL EXTENSION ADDS 40" AT FULL EXTENSION)**

Model	A	B	C	D	E	F	G	H
SI75-174IOX	166"	5-6"	51-55"	47°	48" Max	96" Max	174"	279"
SI75-182IOX	172"	5-6"	51-55"	47°	48" Max	96" Max	182"	287"
SI75-194IOX	173"	5-6"	51-55"	48°	48" Max	IOT Specs	194"	298"

Legend

- OR Outside Rail
- ORX Outside Rail Extendable Tail
- IO Inside/Outside Rail
- IOX Inside/Outside Rail Extendable Tail
- ORT Outside Rail Telescopic
- IOT Inside/Outside Rail Telescopic

Your local dealer:



Our People. Our Products.

190 State Street
P.O. Box 169
Garner, IA 50438
Telephone: (641) 923-3741 • (800) 321-3741
Fax: (641) 923-2812
Internet: www.stellarindustries.com
Email: sales@stellarindustries.com

* All specifications are subject to change without notification

An Employee Owned Company.
Copyright © 2012 Stellar Industries, Inc.

1/12

Waste Systems Equipment, Inc

Invoice

P.O. Box 40878
 Houston, TX. 77240
 Phone # 713-939-0200
 Fax # 713-939-0718
 E-mail wse1975@sbcglobal.net
 Web Site www.WasteSystemsEquipment.com

Date	Invoice #
5/2/2018	2978

Bill To
Freightliner of San Antonio 8700 IH 10 East Converse, TX. 78109

Ship To
Freightliner of San Antonio 8700 IH 10 East Converse, TX 78109

P.O. Number	Terms	Due Date	Ship Date	Via	Rep	WSE Project
		5/2/2018	5/2/2018		RGE	J412832

Quantity	Item Code	Description	Price Each	Amount
1	SI75174OR	75,000# cable roll-off, 174"CA, Outside Rail SN # LFT17C268	29,100.00	29,100.00
1	RP4500SARG	Rack n' Pinion Tarp System SN # 42071	8,100.00	8,100.00
1	Radio	Radio Mounted on new Freightliner 114SD Vin # IFVHG3DV4KHKG0668	589.99	589.99
			Subtotal	\$37,789.99
			Sales Tax (8.25%)	\$0.00
			Total	\$37,789.99
			Payments/Credits	\$0.00

Thank you for your business. Please remit to above address.

Balance Due **\$37,789.99**