

**CHANGE  
ORDER**

**OWNER** X  
**ARCHITECT** X  
**CONTRACTOR** X

PROJECT: Hidalgo County Courthouse  
 Project 1830.007

CONTRACTORS CHANGE ORDER #: 033R  
 DATE: September 16<sup>th</sup>, 2019  
 CONTRACT DATE: March 27<sup>th</sup>, 2018

To County of Hidalgo, Texas:

This Change Order # 033R is entered into by and between Owner and Contractor for the purpose of commencing with the Price for additional services as listed below. All items will be fully funded based on the prices below.

The workorder is changed as follows per approved estimate for additional scope:

		Change Order #33R for CPR 13. Change Design and Finish Material of Sounding Board Ceiling Over Judge's Bench in Courtrooms on Levels 2 (2B-110), 3, 4, 5, 6 and 7 back to sloped with the same wood-look laminate paneling used on the south wall applied to the face. Level 5: 2 Courtrooms considered in this proposal (as per request to add partial Level 5) 4 Courtrooms, Sloped panels for Area B at Level 5 added to this proposal.	\$98,106

**Total Amount for Change Order**      \$ **98,106.00**

Not valid until signed by the Owner and Contractor.

The original (GMP Contract)	\$ 515,065
Early Site/Foundation/Underground Utility Package (GMP AMENDMENT NO.1)	\$ 8,950,855
The 50% CD 100% Structural GMP Package (GMP AMENDMENT NO.2)	\$ 118,410,191
Amendment 3 GMP 3 Interest Earn	\$ 4,195,867
Net change by previously authorized Change Orders - Original	\$
GMP Contract will be Increased by this Change Order in the amount of	\$ 98,106
Contract GMP including this Change Order, previously approve Change Orders and Amendments	\$
Added Scope Amendment 1	Pending
Added Scope Net change by previously authorized Change Orders	\$ 805,443
The (GMP Contract) will be Increased by this Change Order in the amount of	\$
Added Scope Value including this Change Order & GMP Amendments will be	\$ 805,443
<b>Total Contract GMP</b>	<b>\$</b>
The Contract Time for this Change Order will be increased by	0 Days
The Original date of Substantial Completion	February 28, 2021
The Current Date of Substantial Completion	July 13, 2021

PROJECT: Hidalgo County Courthouse  
Project 1830.007

CONTRACTORS CHANGE ORDER #: 033R  
DATE: September 16<sup>th</sup>, 2019  
CONTRACT DATE: March 27<sup>th</sup>, 2018

**Signature Page:**

**Contractor:**

Morganti Texas, Inc.  
10590 West Office Dr. Ste 150  
Houston, Tx 77042

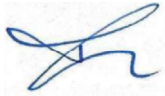

09/16/2019

---

**Architect:**

HDR Architecture, Inc.  
8750 N. Central Expressway  
Dallas, Texas 75231



October 4, 2019

---

**Owner:**

County of Hidalgo, Texas  
2812 S. Business 281  
Edinburg, TX 78539

---

---

---

---



September 16, 2019

**Jacobs**

Change Order #33R for CPR 13. Change Design and Finish Material of Sounding Board Ceiling Over Judge’s Bench in Courtrooms on Levels 2 (2B-110), 3, 4, 5, 6 and 7 back to sloped with the same wood-look laminate paneling used on the south wall applied to the face. Level 5: 2 Courtrooms considered in this proposal (as per request to add partial Level 5) 4 Courtrooms, Sloped panels for Area B at Level 5 added to this proposal.

Dear Mr. Garcia,

Listed below is the additional scope of work along with associated labor and materials to complete the work.

Description	Amount
CPR 13 Angle Panel Walls	\$ 86,715.46
<hr/>	
	<b>Sub-Total</b> \$ 86,715
	<b>Bond</b> \$ 867
	<b>Builder's Risk</b> \$ 867
Levels 2 (2B-110), 3, 4, 5, 6 and 7	<b>CCIP</b> \$ 1,127
	<b>SDI</b> \$ 1,335
	<b>General Conditions</b> \$ 4,336
	<b>Fee</b> \$ 2,857
	<b>Sales Tax</b>
	<b>Total</b> \$ 98,106

Sincerely,

Michael Easley

By signing this proposal, I agree to the change in scope and contract amount.

By: \_\_\_\_\_ Date: \_\_\_\_\_

Jacobs



## Change Price Request

**Project Name:** Hidalgo County Texas -  
NEW COURTHOUSE  
Structural Package

**CPR Number:** 13

**Project Number:** 10085982

**Regarding:**

**Date:** June 7, 2019

### Description of Change:

The revisions can be summarized as follows:

1. Change flooring in Judges' Chambers from carpet (CPT-1) to porcelain tile (PT-3) on Levels 3, 4, 5, 6 and 7 (not Level 2). Change base in these areas from RB-1 to PT-2, cut and installed with Schluter cap profile similar to as specified for the main first level lobby areas. See below snippet from IN-103A as an example.

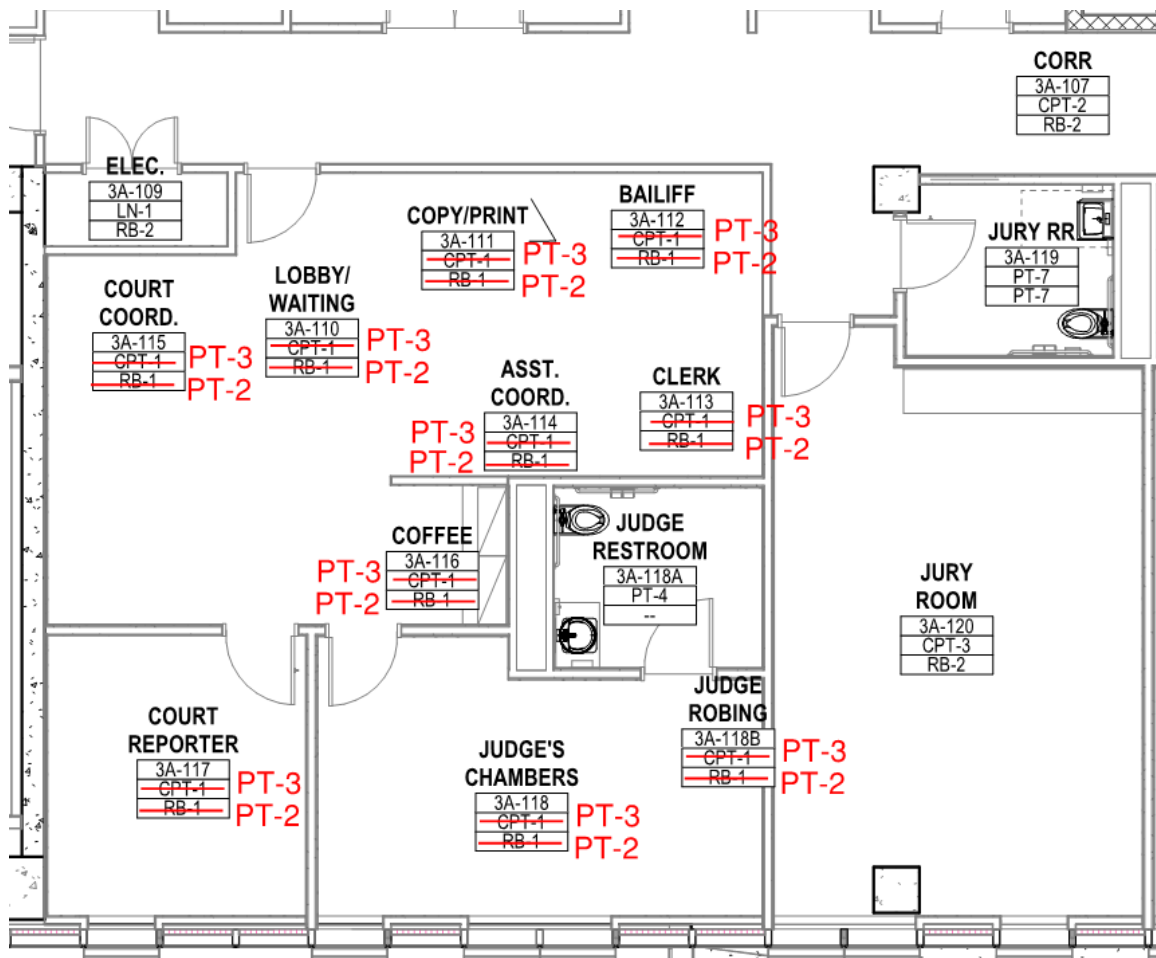



- 2. Change design and finish material of sounding board ceiling over judge’s bench in courtrooms on Levels 2 (2B-110), 3, 4, 5, 6 and 7 back to sloped with the same wood-look laminate paneling used on the south wall applied to the face. Match wall and ceiling panel reveals and wood patterns. Refer to 100% DD drawings (2/A-407 and 6/A-557) and rendering included for concept. Match details submitted by Beaubois (SK10) for applying laminated board to ceiling. Light fixtures D2 and D2W to remain as specified.

**END OF CPR #13**

---

All Work shall be in accordance with the terms, stipulations and conditions of original Contract Documents.

---

<b>Amount:</b> \$	<b>Time Change (Calendar Days):</b>		
<b>Construction Mgr / Contractor:</b> Morganti Texas, Inc.	<b>By:</b>	<b>Date:</b>	<b>Recommendation:</b>
<b>Architect/Engineer:</b> HDR Architecture, Inc.	<b>By:</b>	<b>Date:</b>	<b>Recommendation:</b>
<b>Owner:</b> County of Hidalgo Texas	<b>By:</b>	<b>Date:</b>	<b>Action:</b> [ ] Approved [ ] Rejected

The Contractor is directed to make changes indicated above for the proposed amount and time after Owner approval.  
If allowed by the Contract Documents, this document is considered a fully executed Change Order after Owner approval.

---







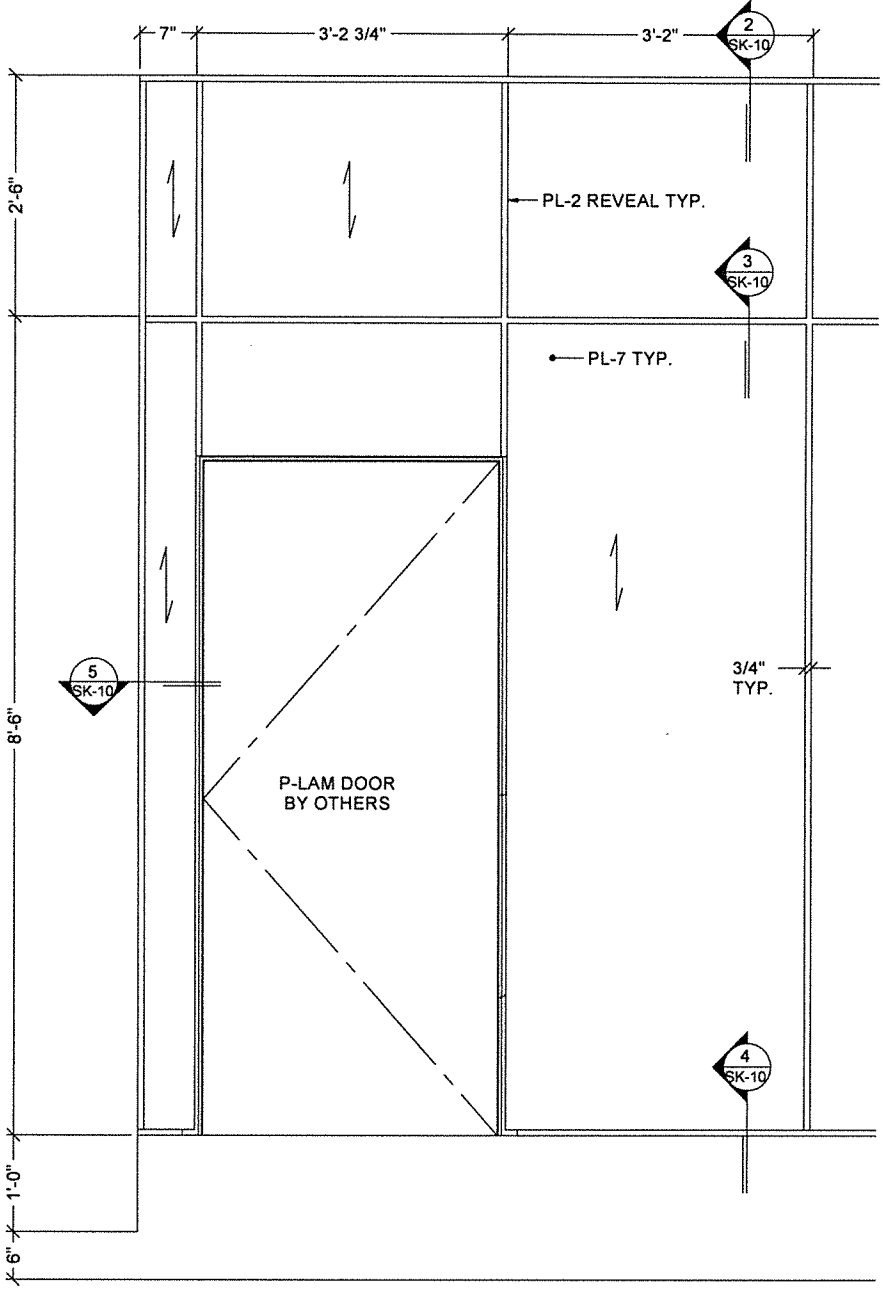

**1 ELEVATION**  
 SK-10 SCALE: 1/2"=1'-0"  
 REF ARCHIT: 3/A-254

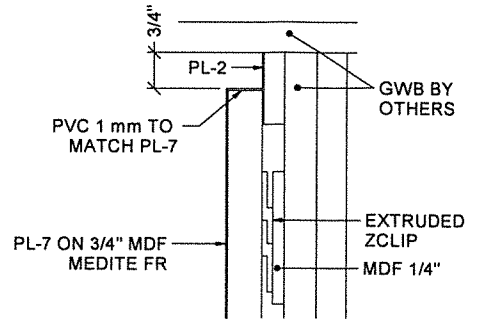

**2 SECTION TYP**  
 SK-10 SCALE: 3"=1'-0"  
 REF ARCHIT: A16/A-559

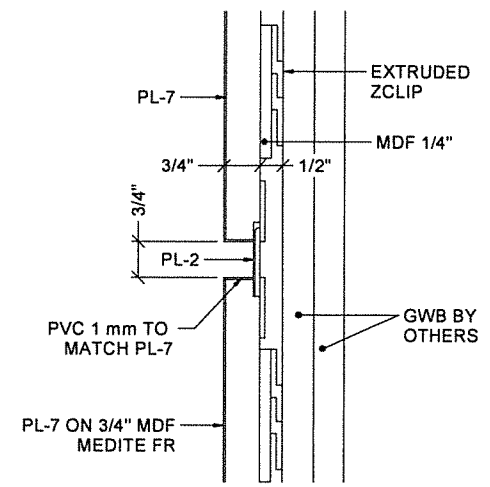

**3 SECTION TYP**  
 SK-10 SCALE: 3"=1'-0"  
 REF ARCHIT: A12/A-559

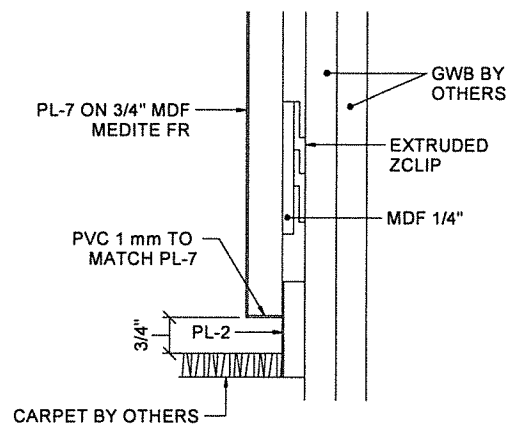

**4 SECTION TYP**  
 SK-10 SCALE: 3"=1'-0"  
 REF ARCHIT: A15/A-559

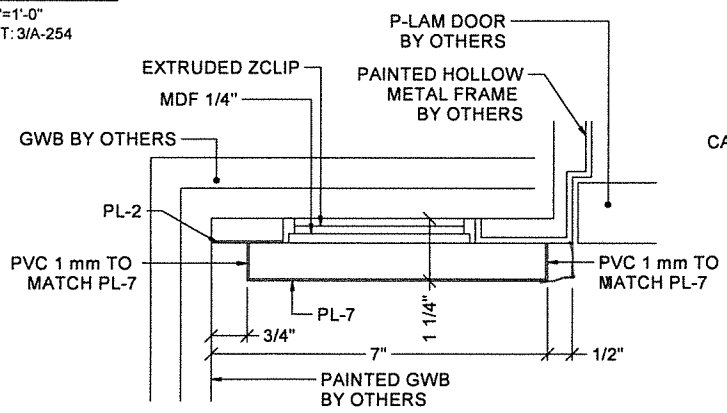

**5 SECTION TYP**  
 SK-10 SCALE: 3"=1'-0"  
 REF ARCHIT: A11/A-559

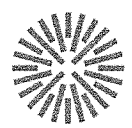

**Beaubois**

PL-2 - FORMICA DECO METAL STAINLESS ALUMINIUM M4194  
 PL-7 - PANOLAM GALAO WX0075-AB

CONTRAT (NO)  
 5207

PROJET / PROJECT  
 Hidalgo County Courthouse

DATE  
 FEBRUARY 2019

PANELING



**Beaubois**
**QUOTATION**
**C-5207-0014**
**Date :** 2019/06/27

**Request :** CPR 13

<b>Client</b>	<u>Morganti Texas inc.</u>	<b>TEL:</b> <u>956-212-4434</u>
<b>Project</b>	<u>Hidalgo County Courthouse</u>	<b>FAX:</b> <u>rgonzalez@morganti.com</u>
<b>Address</b>	<u>Edinburg</u>	
<b>Section:</b>	<u>064023</u>	
<b>ATT:</b>	<u>Robert Gonzalez</u>	
<b>Subject</b>	<u>Angle panels at wall</u>	

The subcontractor shall perform work and will supply all labours, services, equipment, tools, scaffolds, appliances, materials, (fasteners, screws, glue, nails, shim etc..) and other items necessary to provide a professional fabrication and installation of :

**Summary:**

Change design and finish material of sounding board ceiling over judge's bench in courtrooms on Levels 2 (2B-110), 3, 4, 5, 6 and 7 back to sloped with the same wood-look laminate paneling used on the south wall applied to the face.

Level 5: 2 Courtrooms considered in this proposal (as per request to add partial Level 5).  
 REV 02: Sloped panels for Area B at Level 5 added to this proposal, value = 10,821.92\$. 4 courtrooms  
 \$5,410.96 2 courtrooms  
 \$16,232.88 6 courtrooms

**ALL COURTROOMS IN LEVEL 5**

**16 weeks fabrication lead time or as otherwise noted**
**Price valid 30 days or as otherwise noted**

PROJECT MANAGER : Bernard, Stéphane  
 Phone : 418-228-5104 #5380 / Cell : (418)225-1309  
 Fax : stephane.bernard@beaubois.com

Stéphane Bernard  
 Project Manager

**Total:** **86715.46 \$**

<b>F.O.B. ON SITE:</b>	<input type="checkbox"/> Yes <input checked="" type="checkbox"/> No	<b>SUPPLY ONLY</b>	<input type="checkbox"/>
<b>Delivery:</b>	<u>16 weeks after pricing and drawings approval</u>	<b>SUPPLY AND INSTALL</b>	<input checked="" type="checkbox"/>
<b>Payment terms:</b>	<u>As per contractual document</u>		

**Saint-Georges: 521 6e Avenue, Ville de Saint-Georges, Beauce, Qc G5Y 0H1 Tel:(418)228-5104 Fax:(418)228-3524.**

<b>QUOTATION</b>
------------------

**C-5207-0014****Date :** 2019/06/27**Request :** CPR 13**PROJECT** Hidalgo County Courthouse**DESCRIPTION** Angle panels at wall**SUPPLY**

Materials				23495.00 \$
Others materials (shop)				0.00 \$
Shop labour	\$ 45.07 /HR	X	29.00	1307.03 \$
Shop labour Crew chief	\$ 55.04 /HR	X	2.90	159.62 \$
Shipping				3500.00 \$
Inspection, packaging for shipping	\$ 45.07 /HR	X	2.90	130.70 \$
Wrapping material	\$ 1000.00 /HR	X	0.60	600.00 \$
Shop drawing	\$ 36.79 /HR	X	18.00	662.22 \$
Cutting sheet	\$ 36.79 /HR	X	9.00	331.11 \$
Estimation / Estimating	\$ 63.87 /HR	X	12.00	766.44 \$
Materials receiving				502.56 \$
Autres / Others				746.38 \$
<b>SUB-TOTAL: SUPPLY</b>				32201.06 \$
Overhead & Profit 10.00				3220.11 \$
<b>TOTAL: SUPPLY</b>				35421.16 \$

**INSTALL**

Carpenter	\$ 98.00 /HR	X	270.00	26460.00 \$
Carpenter (time and half)	\$ /HR	X		0.00 \$
Carpenter (double time)	\$ /HR	X		0.00 \$
Foreman	\$ 106.00 /HR	X	27.00	2862.00 \$
Foreman (time and half)	\$ /HR	X		0.00 \$
Foreman (double time)	\$ /HR	X		0.00 \$
Superintendant	\$ 128.49 /HR	X	27.00	3469.23 \$
Superintendant (time and half)	\$ /HR	X		0.00 \$
Superintendant (double time)	\$ /HR	X		0.00 \$
Tools				0.00 \$
On-Site receiving, handling and distribution	\$ 98.00 /HR	X	27.00	2646.00 \$
Rev02 Adjustement				9838.11 \$
<b>SUB-TOTAL: INSTALL</b>				45275.34 \$
Overhead & Profit 10.00				4527.53 \$
<b>TOTAL: INSTALL</b>				49802.87 \$

<b>TOTAL SUPPLY AND INSTALL</b>				85224.04 \$
				0.00
TAXES				0.00 \$
Bond				1.75
<b>TOTAL</b>				86715.46 \$



Stéphane Bernard  
Project Manager