



HIDALGO COUNTY PLANNING DEPARTMENT

T.J. Arredondo, CFM
Director of Planning

1304 SOUTH 25TH STREET
EDINBURG TEXAS 78539
Tel. 956-318-2840 Fax. 956-318-2844

HIDALGO COUNTY COMMISSIONERS COURT MEETING

DATE: 5-26-2020

PROPOSED SUNSHINE ESTATES NO. 1 SUBDIVISION PRECINCT No. 1

ENGINEER: QUINTANILLA, HEADLEY & ASSOCIATES DEVELOPER: RICHARD W. RUPPERT

PRELIMINARY APPROVAL FINAL APPROVAL FINAL APPROVAL WITH FINANCIAL GUARANTEE WITH VARIANCE

NUMBER OF LOTS: 58 *SINGLE FAMILY *MULTI-FAMILY COMMERCIAL INDUSTRIAL

ESTIMATED NUMBER OF STREETLIGHTS: 17

FILLING STATIONS: 6

LOCATION DESCRIPTION: WEST OF JESUS FLORES ROAD APPROXIMATELY 210.00 FEET NORTH OF MONTE CRISTO ROAD.

SUBDIVISION LIES WITHIN THE: THE RURAL AREA OF THE COUNTY.

DRAINAGE REPORT WAS APPROVED BY HCDD#1: ON 5-14-2020 PROPERTY LIES WITHIN FLOOD ZONE: "X" AS PER FEMA.

DRAINAGE DESIGN: DRAINAGE WILL BE PROVIDED BY STORM SEWER SYSTEM AND DETENTION WILL BE PROVIDED BY WIDENING THE EXISTING DRAIN DITCH.

ROAD R.O.W. DEDICATION: 30.00 FEET ONTO JESUS FLORES ROAD & 20.00 FEET ONTO MONTE CRISTO ROAD.

H.C.R.O.W. PRELIMINARY APPROVAL DATE: 2-03-2020 BY, DANNY GUZMAN, PCT. 1 R.O.W. AGENT

H.C.H.D. PRELIMINARY APPROVAL DATE: 2-03-20 BY, ENVIRONMENTAL HEALTH DIVISION

SEWER SYSTEM: OSSF'S

WATER SERVICE PROVIDER: N.A.W.S.C. EXISTING LINE SIZE: 12" LOCATION: MONTE CRISTO ROAD.

H.C.E.O.C. PRELIMINARY APPROVAL DATE: 1-31-2020: BY ENVIRONMENTAL COMPLIANCE COORDINATOR

LARGE CONSTRUCTION

The applicant has submitted the required NOI as per Part II, Section E of the TPDES General Permit for Construction Activities (TXR150000) along with a copy of the Erosion Control Plan for the proposed project.

PRELIMINARY APPROVAL FROM THE
HIDALGO COUNTY COMMISSIONERS COURT ON: _____

STAFF RECOMMENDS: **Preliminary Approval** subject to comments and future recommendations by planning and other department.

Final Approval subject to recommendations other departments

Final Approval with financial guarantee.

This subdivision plat has been reviewed and complies with the Hidalgo County Subdivision Rules, Texas Water Development Board Model Subdivision Rules and The Texas Local Government Code.

*

SUBDIVISION PLAT OF:

SUNSHINE ESTATES No. 1

A 67.52 ACRE TRACT OF LAND OUT OF LOTS 15 AND 16, BLOCK 96, MISSOURI-TEXAS LAND AND IRRIGATION COMPANY'S SUBDIVISION, HIDALGO COUNTY, TEXAS, ACCORDING TO THE PLAT OR MAP THEREOF RECORDED IN VOLUME 1, PAGE 29, MAP RECORDS HIDALGO COUNTY, TEXAS, AND ACCORDING TO WARRANTY DEED WITH VENDOR'S LIEN RECORDED UNDER COUNTY CLERK'S DOCUMENT NUMBER 3061165, OFFICIAL RECORDS, HIDALGO COUNTY, TEXAS.

METES AND BOUNDS

A 67.52 ACRE TRACT OF LAND OUT OF LOTS 15 AND 16, BLOCK 96, MISSOURI-TEXAS LAND AND IRRIGATION COMPANY'S SUBDIVISION, HIDALGO COUNTY, TEXAS, ACCORDING TO THE PLAT OR MAP THEREOF RECORDED IN VOLUME 1, PAGE 29, MAP RECORDS HIDALGO COUNTY, TEXAS, AND ACCORDING TO WARRANTY DEED WITH VENDOR'S LIEN RECORDED UNDER COUNTY CLERK'S DOCUMENT NUMBER 3061165, OFFICIAL RECORDS, HIDALGO COUNTY, TEXAS, REFERENCE TO WHICH IS HERE MADE FOR ALL PURPOSES AND BEING MORE PARTICULARLY DESCRIBED BY METES AND BOUNDS AS FOLLOWS.

BEGINNING AT A COTTON PICKER SPINDLE SET ON THE EAST LINE OF LOT 16 AND IN THE CENTERLINE OF JESUS FLORES ROAD FOR THE SOUTHEAST CORNER OF THIS TRACT, SAID SPINDLE BEARS N 09°20' E, 209.38 FEET FROM THE SOUTHEAST CORNER OF LOT 16.

THENCE N 80°40' W, PASSING A 1/2" IRON ROD WITH CAP STAMPED RPLS 4856 SET AT 20.00 FEET FOR THE WEST RIGHT OF WAY LINE OF JESUS FLORES ROAD, A TOTAL DISTANCE OF 906.00 FEET TO A 1/2" IRON ROD WITH CAP STAMPED RPLS 4856 SET FOR AN INTERIOR CORNER OF THIS TRACT.

THENCE S 09°20' W, A DISTANCE OF 125.43 FEET TO A 1/2" IRON ROD WITH CAP STAMPED RPLS 4856 FOR AN INTERIOR CORNER OF THIS TRACT.

THENCE S 35°42' E, A DISTANCE OF 35.33 FEET TO A 1/2" IRON ROD WITH CAP STAMPED RPLS 4856 SET FOR AN EXTERIOR CORNER OF THIS TRACT.

THENCE S 09°20' W, PASSING A 1/2" IRON ROD WITH CAP STAMPED RPLS 4856 SET AT 20.00 FEET FOR THE NORTH RIGHT OF WAY LINE OF MONTE CRISTO ROAD (F.M. 1925), A TOTAL DISTANCE OF 60.00 FEET TO A COTTON PICKER SPINDLE SET ON THE SOUTH LINE OF LOT 16 AND IN THE CENTERLINE OF MONTE CRISTO ROAD (F.M. 1925) FOR AN EXTERIOR CORNER OF THIS TRACT.

THENCE N 80°44' W, ALONG THE SOUTH LINE OF LOT 16 AND THE CENTERLINE OF MONTE CRISTO ROAD (F.M. 1925), A DISTANCE OF 100.00 FEET TO A COTTON PICKER SPINDLE SET FOR AN EXTERIOR CORNER OF THIS TRACT.

THENCE N 09°20' E, PASSING A 1/2" IRON ROD WITH CAP STAMPED RPLS 4856 SET AT 40.00 FEET FOR THE NORTH RIGHT OF WAY LINE OF MONTE CRISTO ROAD (F.M. 1925), A TOTAL DISTANCE OF 60.00 FEET TO A 1/2" IRON ROD WITH CAP STAMPED RPLS 4856 SET FOR AN EXTERIOR CORNER OF THIS TRACT.

THENCE N 54°18' E, A DISTANCE OF 35.38 FEET TO A 1/2" IRON ROD WITH CAP STAMPED RPLS 4856 SET FOR AN INTERIOR CORNER OF THIS TRACT.

THENCE N 09°20' E, A DISTANCE OF 125.49 FEET TO A 1/2" IRON ROD WITH CAP STAMPED RPLS 4856 SET FOR AN INTERIOR CORNER OF THIS TRACT.

THENCE N 80°40' W, A DISTANCE OF 959.20 FEET TO A 1/2" IRON ROD WITH CAP STAMPED RPLS 4856 SET ON THE EAST LINE OF THE 130.00 FOOT ENGELMAN IRRIGATION DISTRICT CANAL RIGHT OF WAY FOR THE SOUTHWEST CORNER OF THIS TRACT.

THENCE N 09°20' E, ALONG THE EAST LINE OF SAID 130.00 FOOT ENGELMAN IRRIGATION DISTRICT CANAL RIGHT OF WAY, A DISTANCE OF 1,528.20 FEET TO A 1/2" IRON ROD WITH CAP STAMPED RPLS 4856 SET FOR THE NORTHWEST CORNER OF THIS TRACT.

THENCE S 80°40' E, PASSING A 1/2" IRON ROD WITH CAP STAMPED RPLS 4856 SET AT 1,895.20 FEET FOR THE WEST RIGHT OF WAY LINE OF JESUS FLORES ROAD, A TOTAL DISTANCE OF 1,915.20 FEET TO A 1/2" IRON ROD WITH CAP STAMPED RPLS 4856 SET ON THE EAST LINE OF LOT 16 AND IN THE CENTERLINE OF JESUS FLORES ROAD FOR THE NORTHEAST CORNER OF THIS TRACT.

THENCE S 09°20' W, ALONG THE EAST LINE OF LOT 16 AND THE CENTERLINE OF JESUS FLORES ROAD, A DISTANCE OF 1,528.20 FEET TO THE POINT OF BEGINNING AND CONTAINING 67.52 ACRES OF LAND MORE OR LESS.

BEARINGS ARE IN ACCORDANCE WITH EL PALAPOTE ACRES SUBDIVISION, RECORDED IN VOLUME 50, PAGES 72 AND 73, MAP RECORDS, HIDALGO COUNTY, TEXAS.

STATE OF TEXAS COUNTY OF HIDALGO

I, THE UNDERSIGNED, A REGISTERED PROFESSIONAL LAND SURVEYOR IN THE STATE OF TEXAS, DO HEREBY CERTIFY THAT THIS PLAT IS TRUE AND CORRECT, AND WAS MADE AND PREPARED FROM AN ACTUAL SURVEY OF THE PROPERTY DONE ON THE GROUND UNDER MY SUPERVISION.



Signature of Alfonso Quintanilla

NOVEMBER 25, 2019 DATE

ALFONSO QUINTANILLA R.P.L.S. No. 4856

PLAT NOTES AND RESTRICTIONS:

- 1.- FLOOD ZONE STATEMENT: FLOOD ZONE DESIGNATION: ZONE "X" AREAS DETERMINED TO BE OUTSIDE 500-YEAR FLOOD PLAIN. COMMUNITY-PANEL NUMBER 480334 0350 C MAP REVISED: NOVEMBER 16, 1982 (LOMR DATE MAY 17, 2001) THE AREAS WITHIN THE DRAINAGE EASEMENTS AND THE PROPOSED STREET RIGHT-OF-WAY ARE WITHIN THE 100-YEAR FLOOD PLAIN, COMMUNITY-PANEL NO. 480334 0350 C EFFECTIVE DATE: NOVEMBER 16, 1982 OF THE FEDERAL EMERGENCY MANAGEMENT AGENCY MAPS FOR HIDALGO COUNTY, TEXAS AND THE LOCAL FLOOD PLAN ADMINISTRATOR HAVE IDENTIFIED NO OTHER AREAS AS SHOWN ON THIS PLAT ARE WITHIN THE PROPOSED SUBDIVISION TO BE WITHIN THE 100-YEAR FLOOD PLAIN. CONSTRUCTION OF RESIDENTIAL HOUSING WITHIN ANY AREA OF THE SUBDIVISION THAT IS IN THE 100-YEAR FLOOD PLAIN IS PROHIBITED UNLESS THE HOUSING QUALIFIES FOR INSURANCE UNDER THE NATIONAL FLOOD INSURANCE ACT OF 1968 (42 U.S.C. SECTIONS 4001 THROUGH 4127).
- 2.- LEGEND - DENOTES 1/2" IRON ROD SET WITH PLASTIC CAP STAMPED RPLS 4856, UNLESS OTHERWISE NOTED.
- 3.- SETBACKS: MINIMUM REQUIREMENTS-OWNER MAY DESIGNATE STRICTER REQUIREMENTS. FRONT 25.00 FEET REAR 15.00 FEET SIDE 6.00 FEET CORNER GARAGE FRONT 18.00 FEET CORNER SIDE WHERE ROW IS GREATER THAN 50.00 FEET 20.00 FEET OR EASEMENT WHICHEVER IS GREATER IN ALL CASES.
- 4.- GENERAL NOTE FOR SINGLE FAMILY RESIDENCE NO MORE THAN ONE-SINGLE FAMILY DETACHED DWELLING SHALL BE LOCATED ON EACH LOT. THIS MUST BE STIPULATED ON ALL DEEDS AND CONTRACTS FOR DEEDS. (ANY OTHER USE SHALL REQUIRE PLANNING DEPARTMENT, OFFICE OF ENVIRONMENTAL COMPLIANCE, HEALTH DEPARTMENT AND FIRE MARSHALL APPROVAL). APPLICATIONS FOR CONSTRUCTION ARE REQUIRED PRIOR TO OCCUPYING THE LOT.
- 5.- MINIMUM FINISHES FLOOR NOTE: MINIMUM FINISH FLOOR ELEVATION SHALL BE 18" ABOVE THE CENTER LINE OF STREET OR 18" ABOVE NATURAL GROUND, WHICHEVER IS GREATER. ELEVATION CERTIFICATE MAY BE REQUIRED FOR LOTS LOCATED OUTSIDE A DESIGNATED FLOOD ZONE AT THE TIME FOR APPLICATION FOR CONSTRUCTION TO VERIFY PRE AND POST CONSTRUCTION FINISH FLOOR ELEVATIONS. AN ELEVATION CERTIFICATE SHALL BE REQUIRED FOR ALL LOTS WITHIN A DESIGNATED FLOOD ZONE AT THE TIME FOR A DEVELOPMENT PERMIT APPLICATION.
- 6.- BENCHMARK NOTE: THE FOLLOWING BENCHMARK IS IDENTIFIED ON THE FACE OF THE PLAT AND ON THE ATTACHED ENGINEERING PLANS. B.M. No. 1: ELEV.=70.60, TOP OF INLET FOUND ON THE NORTHWEST CORNER OF LOT 8 OF THE SUBDIVISION NAVD 88 DATUM. B.M. No. 2: ELEV.=68.00, TOP OF INLET FOUND ON THE NORTHWEST CORNER OF LOT 20 OF THE SUBDIVISION NAVD 88 DATUM.
- 7.- DRAINAGE: IN ACCORDANCE WITH THE HIDALGO COUNTY DRAINAGE DISTRICT NO. 1 AND HIDALGO COUNTY REQUIREMENTS, THIS DEVELOPMENT WILL BE REQUIRED TO DETAIN A TOTAL OF 193,024.69 CUBIC FEET 4.43 ACRE FEET OF STORM WATER RUNOFF. DRAINAGE RETENTION IN ACCORDANCE WITH THE LOCAL REQUIREMENTS WILL BE ACCOMPLISHED AS FOLLOWS: SEE DRAINAGE REPORT ON SHEET NO. 5
- 8.- ON-SITE SEWAGE FACILITIES (OSSF) NOTE: THIS SUBDIVISION SHALL USE ON-SITE SEWAGE FACILITIES IN ACCORDANCE WITH TCEQ AND HIDALGO COUNTY REGULATIONS FOR SEWAGE DISPOSAL. THE SUBDIVIDER IS RESPONSIBLE FOR PROVIDING AN OSSF ON ALL LOTS. A. OSSF SYSTEM IS BEING DESIGNED FOR DISPOSAL OF DOMESTIC SEWAGE ONLY A SEPARATED DESIGN SHALL BE SUBMITTED FOR COMMERCIAL USE. B. EACH LOT ON THIS PLAT COMPLIES WITH THE MINIMUM 21,780 SQUARE FEET LOT AREA WITH POTABLE WATER SUPPLY. C. OSSF SYSTEM SHALL REQUIRE INSPECTION AND APPROVAL BY HIDALGO COUNTY AUTHORIZED DEPARTMENT. D. SOIL ANALYSIS HAVE BEEN SUBMITTED TO THE AUTHORIZED HIDALGO COUNTY DEPARTMENT AND EXCERPT MAY BE ALSO SEEN ON THE UTILITY LAYOUT FOR THIS SUBDIVISION AS SUBMITTED TO THE HIDALGO COUNTY PLANNING DEPARTMENT. THE SOIL EVALUATOR HAS DETERMINED THAT THE SOIL IS SUITABLE FOR A STANDARD SEPTIC TANK AND ABSORPTIVE DRAINFIELD SYSTEM. E. APPROVED "OSSF" PERMIT APPLICATION IS REQUIRED INCLUDING INDIVIDUAL LOT PLANNING MATERIALS PRIOR TO OCCUPYING A LOT.
- 9.- THERE ARE NO WATER WELLS WITHIN 150 FEET FROM THE BOUNDARIES ON THIS SUBDIVISION. GIRASOL DEVELOPMENT GROUP, LLC
- 10.- BY, RICHARD W. RUPPERT, THE OWNER & SUBDIVIDER OF SUNSHINE ESTATES No. 1 RETAINS AN EASEMENT UPON EACH LOT FOR THE PURPOSE OF INSTALLING AN APPROVED OSSF ON THE LOT AS DESCRIBED ON SHEET No. 3 OF THIS PLAT.
- 11.- NO STRUCTURE SHALL BE PERMITTED OVER ANY EASEMENT. EASEMENTS SHALL BE KEPT CLEAR OF FENCES, BUILDINGS, SHEDS, SHRUBS TREES, AND OTHER PLANTINGS (EXCEPT LOW, LESS THAN 18 INCHES MATURE HEIGHT, GROUND COVER, GRASS, OR FLOWERS) AND OTHER OBSTRUCTIONS TO THE OPERATION AND MAINTENANCE OF THE EASEMENT.
- 12.- EACH PURCHASED CONTRACT MADE BETWEEN A SUBDIVIDER AND PURCHASER OF A LOT IN THIS SUBDIVISION SHALL CONTAIN A STATEMENT DESCRIBING HOW AND WHEN WATER, SEWER, ELECTRICITY AND GAS SERVICES WILL BE MADE AVAILABLE TO THE SUBDIVISION.
- 13.- ALL PUBLIC UTILITIES EASEMENTS DEDICATED BY THIS PLAT SHALL BE A MINIMUM WIDTH OF 15.00 FEET AS PER THE HIDALGO COUNTY MODEL SUBDIVISION RULES. BY SIGNING THIS PLAT DEVELOPER AND ENGINEER CERTIFY THAT ALL OTHER EASEMENTS SHOWN COMPLY WITH THE SIZE REQUIRED BY EACH UTILITY PROVIDER OCCUPYING AN EASEMENT.
- 14.- ALL LOTS SHALL HAVE A POST DEVELOPMENT FINISHED GRADE FROM THE REAR OF THE LOT TO THE CURB AND/OR ROADSIDE DITCH AT A 0.25% SLOPE TO ACCOMPLISH POSITIVE DRAINAGE. THIS IS IN ACCORDANCE WITH HIDALGO COUNTY SUBDIVISION RULES APPENDIX 3.1.4.
- 14.- NO ACCESS FROM LOTS ONTO JESUS FLORES ROAD WILL BE ALLOWED

RIGHT OF WAY EASEMENT

KNOW ALL MEN BY THESE PRESENTS, that the undersigned, owners of the property shown on this plat, their successors, assigns, and transferees (hereinafter called "Grantor" whether one or more persons are named), in consideration of one dollar (\$1.00) and other good and valuable consideration paid by North Alamo Water Supply Corporation, (hereinafter called "Grantee"), the receipt and sufficiency of which is hereby acknowledged, does hereby grant, bargain, sell, transfer, and convey to said Grantee, its successors, and assigns, an exclusive perpetual easement with the right to erect, construct, install and thereafter use, operate, inspect, repair, maintain, replace, and remove water distribution lines and appurtenances over and across the lands shown on this plat, together with the right of ingress and egress over Grantor's adjacent lands for the purpose for which the above mentioned rights are granted. The easement hereby granted shall not exceed 15' in width, and Grantee is hereby authorized to designate the course of the easement herein conveyed except that when the pipeline(s) is installed, the easement herein granted shall be limited to a strip of land 15' in width, the center line thereof being the pipeline installed.

In the event the easement hereby granted abuts on a public road and the city, county or state hereafter widens or relocates the public road so as to require the relocation of this water line as installed, Grantor further grants to Grantee an additional easement over and across the land shown on this plat for the purpose of laterally relocate said water line as may be necessary to clear the road improvements, which easement hereby granted shall be limited to a strip of land 15' in width, the center line thereof being the pipeline as relocated.

The consideration recited herein shall constitute payment in full for all damages sustained by Grantor by reason of the installation, maintenance, repair, replacement and relocation of the structures referred to herein. This agreement together with other provisions of this grant shall constitute an easement for the benefit of the Grantee, its successors, and assigns. The Grantor covenants that it is the owner of the above-described lands and that said lands are free and clear of all encumbrances and liens except the following:

The easement conveyed herein was obtained or improved through Federal financial assistance. This easement is subject to the provisions of Title VI of the Civil Rights Act of 1964 and the regulations issued pursuant thereto for so long as the easement continues to be used for the same or similar purpose for which financial assistance was extended or for so long as the Grantee owns it, whichever is longer.

IN WITNESS WHEREOF the said Grantor executed this instrument this 20th day of _____, 20__.

GIRASOL DEVELOPMENT GROUP, LLC BY, RICHARD W. RUPPERT 2810 N. CLOISNER BLVD. EDINBURG, TX, 78541

HIDALGO COUNTY CERTIFICATE OF PLAT APPROVAL

I, THE UNDERSIGNED CERTIFY THAT THIS PLAT OF SUNSHINE ESTATES No. 1 WAS REVIEWED AND APPROVED BY THE HIDALGO COUNTY HEALTH DEPARTMENT ON _____, 20__.

ENVIRONMENTAL HEALTH DIVISION MANAGER DATE

INDEX OF SHEETS

- SHEET 1.- HEADING INDEX: LOCATION MAP AND ETJ: PRINCIPAL CONTACTS: MAP: DESCRIPTION (METES AND BOUNDS); ENGINEER'S & SURVEYOR'S CERTIFICATION: PLAT NOTES AND RESTRICTIONS; OWNER'S DEDICATION, CERTIFICATION, ATTESTATION; COUNTY JUDGE CERTIFICATE: COUNTY CLERK'S RECORDING CERTIFICATE: H.C.D.D. No. 1 CERTIFICATION HIDALGO COUNTY HEALTH DEPARTMENT CERTIFICATE: ENGELMAN IRRIGATION DISTRICT CERTIFICATION: REVISION NOTES
- SHEET 2.- MAP, HEADING INDEX: LOCATION MAP AND ETJ: PRINCIPAL CONTACTS: MAP: LOT, STREETS, AND EASEMENT LAYOUT: LINE AND CURVE DATA: ENGINEER'S & SURVEYOR'S CERTIFICATION: COUNTY CLERK RECORDING CERTIFICATE, REVISION NOTES
- SHEET 3.- MAP OF WATER DISTRIBUTION SYSTEM, ENGINEER'S CERTIFICATION, COUNTY CLERK'S RECORDING CERTIFICATE, REVISION NOTES.
- SHEET 4.- MAP OF TOPOGRAPHY AND DRAINAGE, ENGINEER'S CERTIFICATION, COUNTY CLERK'S RECORDING CERTIFICATE, REVISION NOTES.
- SHEET 5.- ENGINEERING REPORT, INCLUDING DESCRIPTION OF WATER AND WASTE WATER/OSSF AND ENGINEER'S CERTIFICATION (ENGLISH AND SPANISH VERSION) SUBDIVIDER CERTIFICATE & STATEMENT, DRAINAGE REPORT INCLUDING DESCRIPTION OF DRAINAGE WITH ENGINEER'S CERTIFICATION, CONSTRUCTION DETAILS, COUNTY CLERK'S RECORDING CERTIFICATE, REVISION NOTES.

STATE OF TEXAS COUNTY OF HIDALGO OWNER'S DEDICATION, CERTIFICATION, AND ATTESTATION

GIRASOL DEVELOPMENT GROUP, LLC BY, RICHARD W. RUPPERT AS OWNER OF THE 67.52 ACRE TRACT OF LAND ENCOMPASSED WITHIN THE PROPOSED SUNSHINE ESTATES No. 1, I HEREBY SUBDIVIDE THE LAND AS DEFINED IN THIS SUBDIVISION PLAT AND DEDICATE TO PUBLIC USE THE STREET, PARK, AND EASEMENTS SHOWN HEREIN. WE CERTIFY THAT WE HAVE COMPLIED WITH THE REQUIREMENTS OF TEXAS LOCAL GOVERNMENT CODE §232.032 AND THAT: (A) THE WATER QUALITY AND CONNECTIONS TO THE LOTS MEET, OR WILL MEET, THE MINIMUM STATE STANDARDS; (B) SEWER CONNECTIONS TO THE LOTS OR SEPTIC TANKS MEET, OR WILL MEET, THE MINIMUM REQUIREMENTS OF STATE STANDARDS; (C) ELECTRICAL CONNECTIONS PROVIDED TO THE LOTS MEET, OR WILL MEET, THE MINIMUM STATE STANDARDS; AND (D) GAS CONNECTIONS, IF AVAILABLE, PROVIDED TO THE THE LOTS MEET, THE MINIMUM STATE STANDARDS. WE ATTEST THAT THE MATTERS ASSERTED IN THIS PLAT ARE TRUE AND COMPLETE.

GIRASOL DEVELOPMENT GROUP, LLC BY, RICHARD W. RUPPERT 2810 N. CLOISNER BLVD. EDINBURG, TX, 78541

STATE OF TEXAS COUNTY OF HIDALGO

BEFORE ME, the undersigned notary public, on this day personally appeared RICHARD W. RUPPERT, GIRASOL DEVELOPMENT GROUP, LLC proved to me through his Texas Department of Public Safety Driver License to be the person whose name is subscribed to the foregoing instrument, who, being by me first duly sworn, declared that the statements therein are true and correct and acknowledged that he executed the same for the purposes and consideration therein expressed. Given under my hand and seal of office this _____ day of _____, 20__.

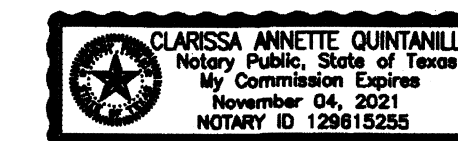

CLARISSA ANNETTE QUINTANILLA - NOTARY PUBLIC

HIDALGO COUNTY CERTIFICATE OF PLAT APPROVAL UNDER LOCAL GOVERNMENT CODE § 232.028(c)

WE, THE UNDERSIGNED CERTIFY that this plat of the SUNSHINE ESTATES No. 1 was reviewed and approved by the Hidalgo County Commissioners Court on _____, 20__.

Hidalgo County Judge Date Hidalgo County Clerk Date

APPROVED BY DRAINAGE DISTRICT:

HIDALGO COUNTY DRAINAGE DISTRICT NO. 1 HEREBY CERTIFIES THAT THE DRAINAGE PLANS FOR THIS SUBDIVISION COMPLY WITH THE MINIMUM STANDARDS OF THE DISTRICT ADOPTED UNDER THE TEXAS WATER CODE 49.211 (c). THE DISTRICT HAS NOT REVIEWED AND DOES NOT CERTIFY THAT THE DRAINAGE STRUCTURES DESCRIBED ARE APPROPRIATE FOR THE SPECIFIC SUBDIVISION BASED ON GENERALLY ACCEPTED ENGINEERING CRITERIA. IT IS THE RESPONSIBILITY OF THE DEVELOPER AND HIS ENGINEER TO MAKE THEIR DETERMINATIONS.

HIDALGO COUNTY DRAINAGE DISTRICT NO. 1

RAUL SESIN, P.E., C.F.M. GENERAL MANAGER

STATE OF TEXAS COUNTY OF HIDALGO

THIS PLAN IS HEREBY APPROVED BY THE ENGELMAN IRRIGATION DISTRICT SUBJECT TO THE CONDITION THAT IF IRRIGATION FROM SAID DISTRICT IS DESIRED TO THE INDIVIDUAL LOTS IN SAID SUBDIVISION, PROVISION SHALL BE MADE FOR APPROPRIATE EASEMENT FOR THE INSTALLATION OF NECESSARY IRRIGATION FACILITIES TO SUCH LOTS FROM THE CLOSEST WATER DISTRICT DELIVERY POINT AND IT SHALL BE THE RESPONSIBILITY OF THE OWNER OF THE PROPERTY TO INSTALL SUCH NECESSARY FACILITIES.

DISTRICT PRESIDENT DATE SECRETARY DATE

STATE OF TEXAS COUNTY OF HIDALGO

I, THE UNDERSIGNED, A LICENSED PROFESSIONAL ENGINEER IN THE STATE OF TEXAS, DO HEREBY CERTIFY THAT THE PROPER ENGINEERING CONSIDERATIONS HAVE BEEN GIVEN TO THIS PLAT.



ALFONSO QUINTANILLA P.E. No. 95534

4-15-2020 DATE



FILED FOR RECORD IN HIDALGO COUNTY ARTURO GUAJARDO, JR. HIDALGO COUNTY CLERK

ON: _____ AT _____ AM/PM INSTRUMENT NUMBER _____ OF THE MAP RECORDS OF HIDALGO COUNTY, TEXAS BY: _____ DEPUTY

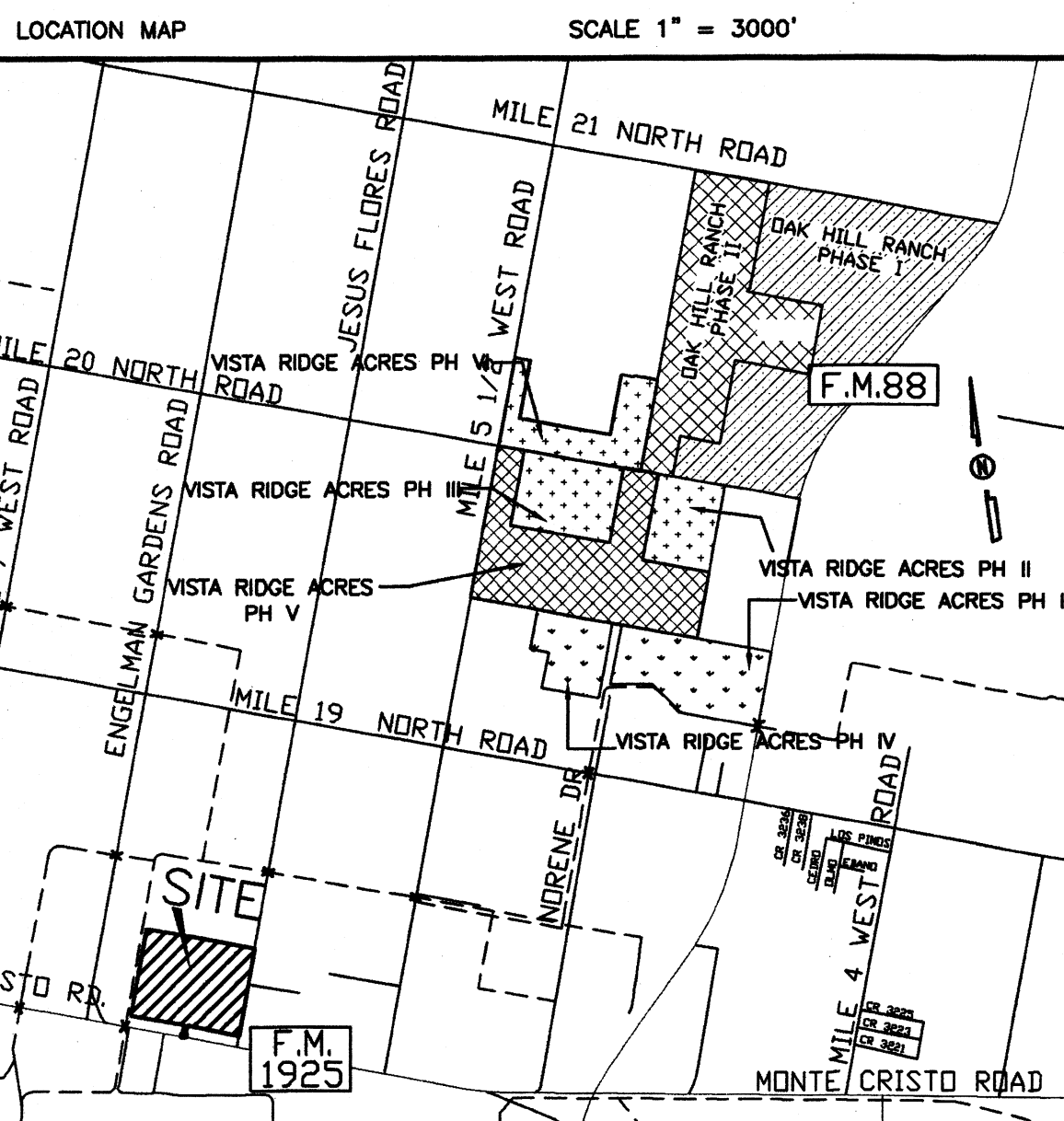

LOCATION OF SUBDIVISION WITH RESPECT TO THE EXTRATERRITORIAL JURISDICTION OF A MUNICIPALITY: SUNSHINE ESTATES No. 1, IS LOCATED IN EASTERN HIDALGO COUNTY ON THE WEST SIDE OF JESUS FLORES ROAD AND ON THE NORTH SIDE OF MONTE CRISTO ROAD APPROXIMATELY 209.38 FEET NORTH FROM THE CITY LIMITS. THE ONLY NEARBY MUNICIPALITY IS THE CITY OF ELSA ACCORDING TO THE OFFICIAL MAP IN THE OFFICE OF THE SECRETARY OF THE CITY OF ELSA (POPULATION 6,578). SUNSHINE ESTATES No. 1, LIES APPROXIMATELY 1.57 MILES FROM THE CITY LIMITS AND FALLS IN THE RURAL AREA OF THE COUNTY, IT LIES IN PRECINCT No. 1.

PRINCIPAL CONTACTS: Table with columns: Name, Address, City & Zip, Phone, Fax. Includes Girasol Development Group, LLC, Alfonso Quintanilla, and Richard W. Ruppert.

REVISION NOTES Table with columns: No., Sheet, REVISION, Date, Approved.

QUINTANILLA, HEADLEY AND ASSOCIATES, INC. CONSULTING ENGINEERS LAND SURVEYORS 124 E. STUBBS ST. EDINBURG, TEXAS 78539 PHONE 956-381-6480 FAX 956-381-0527 ENGINEERING REGISTRATION NUMBER F-1513 ALFONSO@QHA-ENG.COM SURVEYING REGISTRATION NUMBER 100411-00

FILENAME: F:\DATA\SUBD\HIDALGO CO\SUNSHINE ESTATES No. 1\PLAT SUNSHINE Table with columns: DATE PREPARED, PREPARED BY, CHECKED BY, APPROVED BY, DATE REVISED, REVISED BY, CHECKED BY, APPROVED BY.

MAP OF WATER DISTRIBUTION SYSTEM/ MAPA DE DISTRIBUCION DE AGUA

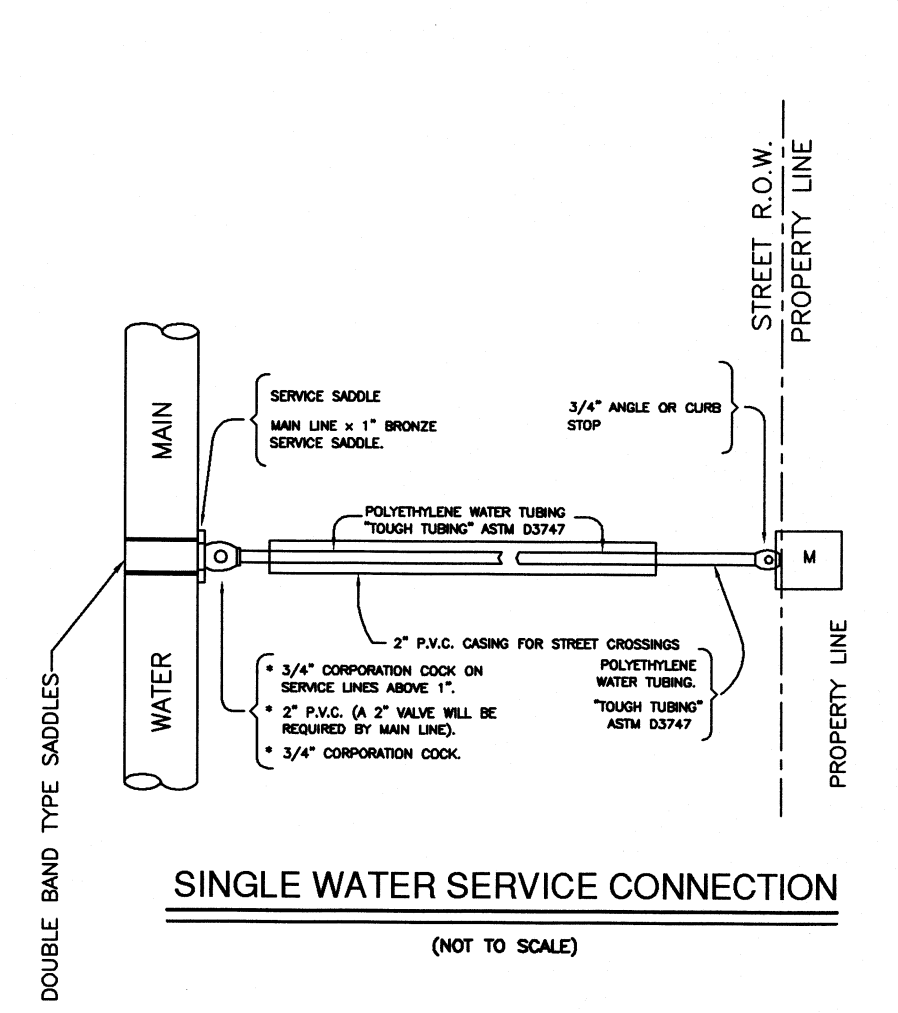
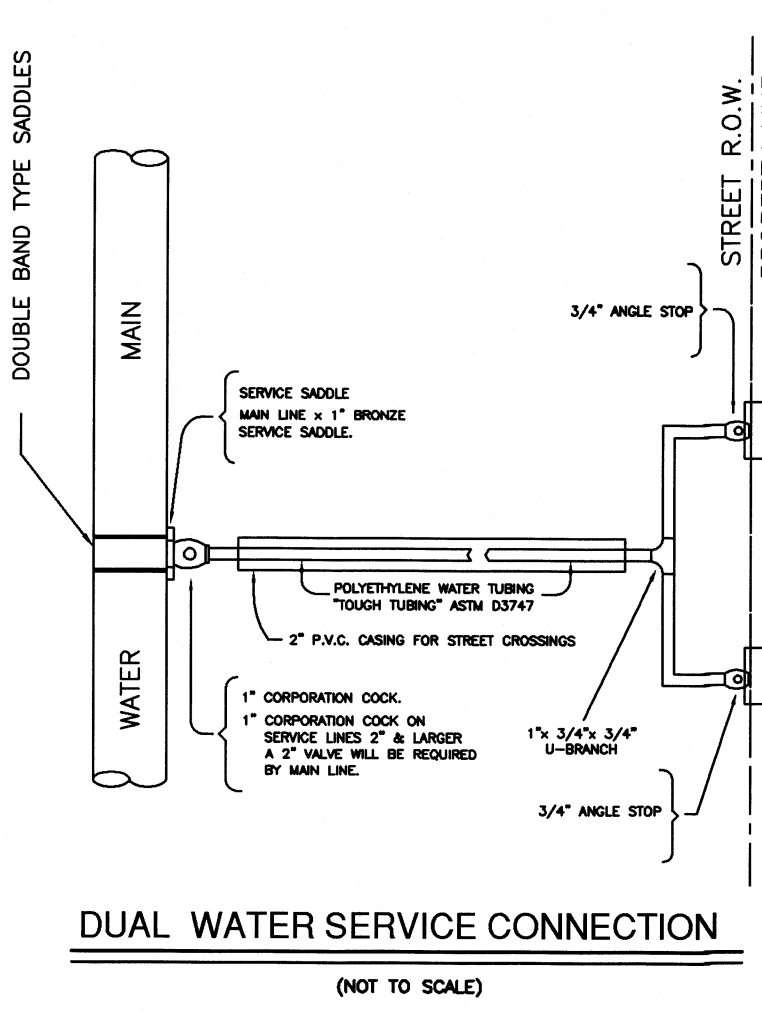
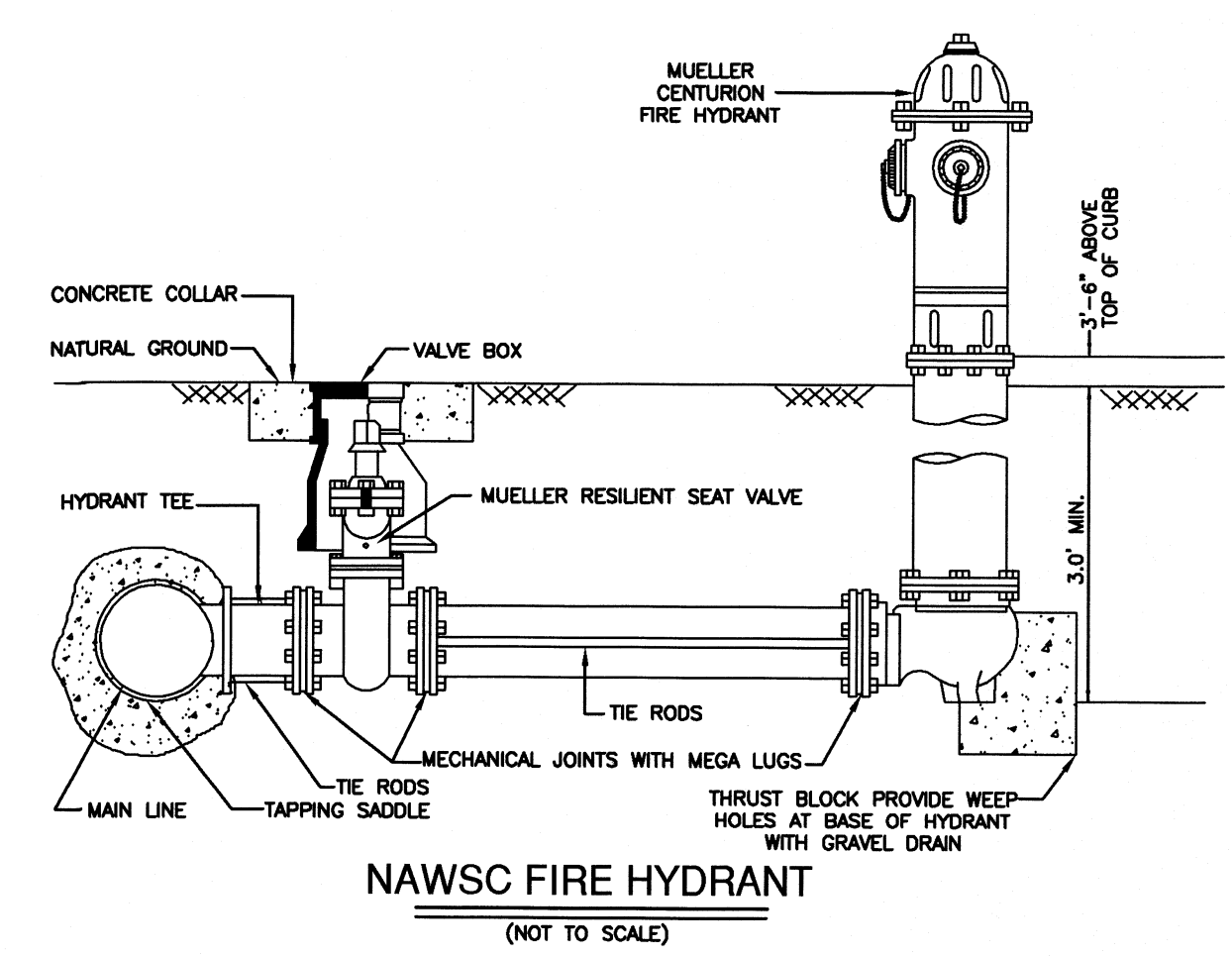
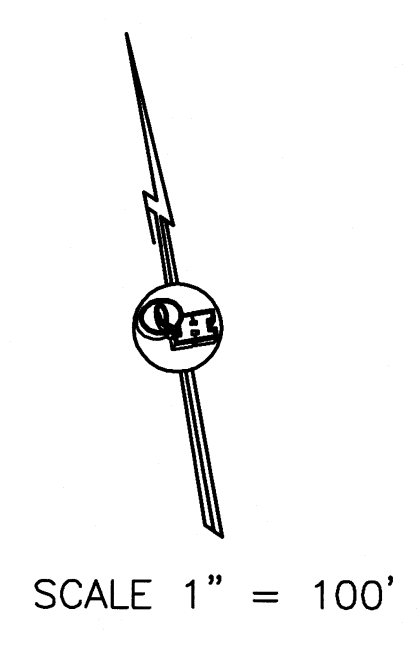
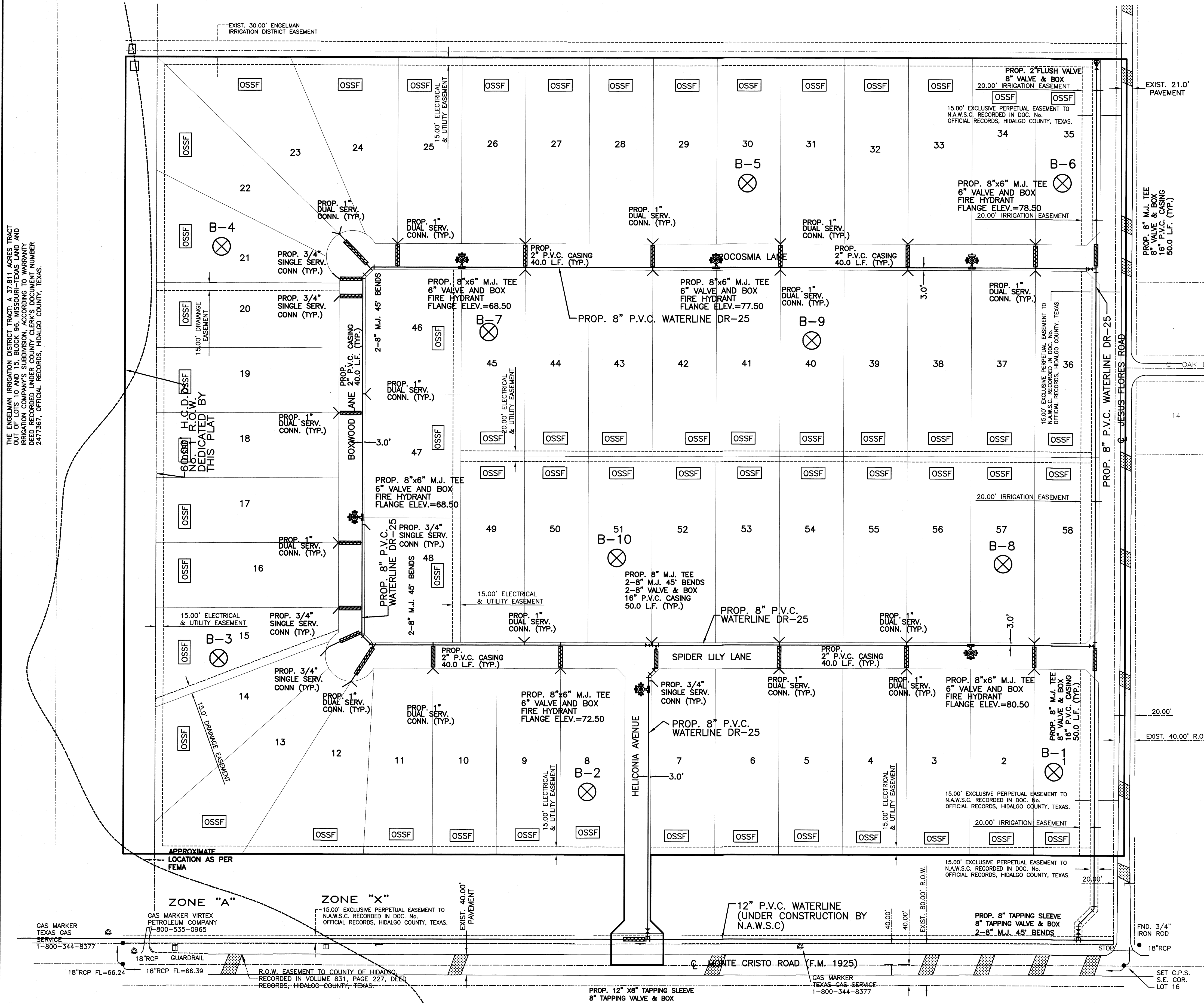

- B-1 TEST BORINGS
- ⊗ PRUEBA DE PERFORACION
- OSSF SEPTIC TANK (OSSF)
- TANQUE SEPTICO (OSSF)
- WATER METER BOX
- CAJA DE MEDIDOR DE AGUA
- 8" WATER SUPPLY LINE
- 8" LINEA DE AGUA
- SERVICE LINES
- LINEAS DE SERVICIOS

COST ESTIMATE

WATER DISTRIBUTION:	\$
DRAINAGE IMPROVEMENTS:	\$
PAVING IMPROVEMENTS:	\$
SEPTIC TANK (OSSF):	\$

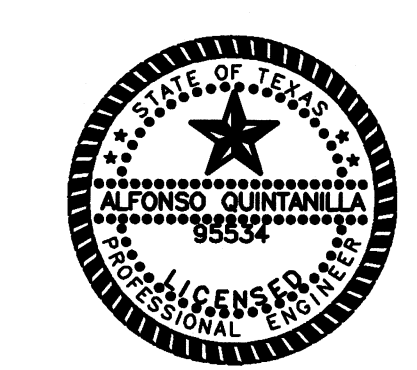

Alfonso P.E. 5-7-2020
 ALFONSO QUINTANILLA P.E. No. 95534
 DATE

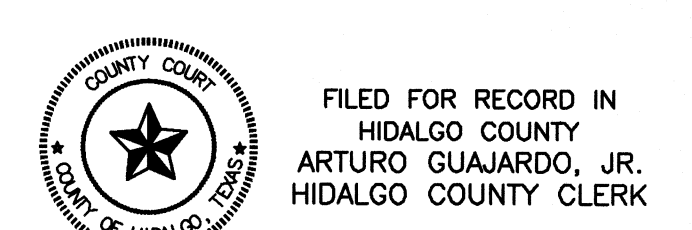

FILED FOR RECORD IN HIDALGO COUNTY ARTURO GUAJARDO, JR. HIDALGO COUNTY CLERK

ON: _____ AT _____ AM/PM
 INSTRUMENT NUMBER _____
 OF THE MAP RECORDS OF HIDALGO COUNTY, TEXAS
 BY: _____ DEPUTY

REVISION NOTES

No.	Sheet	REVISION	Date	Approved

QUINTANILLA, HEADLEY AND ASSOCIATES, INC.
 CONSULTING ENGINEERS LAND SURVEYORS
 124 E. STUBBS ST. PHONE 956-381-6480
 EDINBURG, TEXAS 78539 FAX 956-381-0527
 ENGINEERING REGISTRATION NUMBER F-1513 ALFONSO@QHA-ENG.COM
 SURVEYING REGISTRATION NUMBER 100411-00

SHEET NO. 3 OF 5 SHEETS

FILENAME	DATE PREPARED	PREPARED BY	CHECKED BY	APPROVED BY
F:\DATA\SUBD\HIDALGO CO.\SUNSHINE ESTATES No. 1\WATER BPLAT	5-21-2020	JULIS OVES	G.C.	

SUNSHINE ESTATES No. 1

A 67.52 ACRE TRACT OF LAND OUT OF LOTS 15 AND 16, BLOCK 96, MISSOURI-TEXAS LAND AND IRRIGATION COMPANY'S SUBDIVISION, HIDALGO COUNTY, TEXAS, ACCORDING TO THE PLAT OR MAP THEREOF RECORDED IN VOLUME 1, PAGE 29, MAP RECORDS HIDALGO COUNTY, TEXAS, AND ACCORDING TO WARRANTY DEED WITH VENDOR'S LIEN RECORDED UNDER COUNTY CLERK'S DOCUMENT NUMBER 3061165, OFFICIAL RECORDS, HIDALGO COUNTY, TEXAS.

FINAL ENGINEERING REPORT FOR SUNSHINE ESTATES No. 1

BY ALFONSO QUINTANILLA, P.E.

WATER SUPPLY: Description, Costs, and Operability date

SUNSHINE ESTATES No. 1 WILL BE PROVIDED WITH POTABLE WATER BY THE NORTH ALAMO WATER SUPPLY CORPORATION ("N.A.W.S.C."), THE SUBDIVIDER AND N.A.W.S.C. HAVE ENTERED INTO A CONTRACT IN WHICH N.A.W.S.C. HAS PROMISED TO PROVIDE SUFFICIENT WATER TO THE SUBDIVISION FOR AT LEAST 30 YEARS AND N.A.W.S.C. HAS PROVIDED DOCUMENTATION TO SUFFICIENTLY ESTABLISH THE LONG TERM QUANTITY AND QUALITY OF THE AVAILABLE WATER SUPPLIES TO THE FULL DEVELOPMENT OF THIS SUBDIVISION. N.A.W.S.C. HAS AN EXISTING 12" DIAMETER WATERLINE RUNS ON THE NORTH SIDE OF MONTE CRISTO ROAD (F.M. 1925).

THE WATER SYSTEM FOR SUNSHINE ESTATES No. 1, CONSIST OF A 8" DIAMETER WATERLINE THAT TAPS INTO THE EXISTING 12" DIAMETER WATERLINE ON THE NORTH SIDE OF MONTE CRISTO ROAD (F.M. 1925) THEN THE 8" DIAMETER WATERLINE RUNS NORTH ALONG THE WEST SIDE OF JESUS FLORES ROAD THENCE WEST ALONG THE NORTH SIDE OF SPOKE 1.7 LANE, THENCE EAST ALONG THE SOUTH SIDE OF CROSSCAMA LANE AND IT LOOPS BACK INTO THE 8" DIAMETER WATERLINE ON JESUS FLORES ROAD. ANOTHER 8" DIAMETER WATERLINE ON HELICONIA AVENUE TAPS ON THE LINE 12" DIAMETER WATERLINE THAT RUNS EAST AND WEST ALONG THE NORTH SIDE OF MONTE CRISTO ROAD (1925).

FROM THE PROPOSED 8" WATERLINES, TWENTY-SIX (26) 1" DUAL WATER SERVICES RUN TO PAIRS OF LOTS BEFORE SPLITTING INTO TWO (2) 3/4" DIAMETER SINGLE SERVICES GOING TO THE METER BOXES FOR EACH LOT AND SIX (6) 3/4" DIAMETER SINGLE SERVICE LINES SAID SERVICES TERMINATE AT THE WATER METER BOXES FOR EACH LOT. SIX (6) FIRE HYDRANTS WERE INSTALLED THROUGH OUT THE ENTIRE SUBDIVISION.

THE 8" DIAMETER WATERLINE, THE 1" DUAL SERVICES, SINGLE SERVICE AND THE METER BOXES HAVE BEEN INSTALLED, AT A TOTAL COST OF \$ OR \$ PER LOT. IN ADDITION, THE SUBDIVIDER HAS PAID N.A.W.S.C. THE SUM OF \$ WHICH COVERS THE \$ COST PER ANNUAL 30 YEAR WATER SERVICE AGREEMENT WHICH SUM REPRESENTS THE TOTAL COST OF WATER METER, WATER RIGHTS ACQUISITION FEES, AND ALL MEMBERSHIP OR OTHER FEES ASSOCIATED WITH CONNECTING THE INDIVIDUAL LOTS IN THE SUBDIVISION TO N.A.W.S.C. UPON REQUEST BY THE LOT OWNER, N.A.W.S.C. WILL PROMPTLY INSTALL AT NO CHARGE THE WATER METER FOR THAT LOT. THE ENTIRE WATER FACILITIES HAVE BEEN APPROVED AND ACCEPTED BY N.A.W.S.C. AND SAID DISTRIBUTION SYSTEM IS OPERABLE AS OF THE DATE OF THE RECORDING OF THE PLAT.

SEWAGE FACILITIES: Description, Costs, and Operability Date

SEWAGE FROM SUNSHINE ESTATES No. 1, WILL BE TREATED BY INDIVIDUAL ON-SITE SEWAGE FACILITIES ("OSSF") CONSISTING OF A STANDARD DESIGN DUAL COMPARTMENT SEPTIC TANK AND A DRAINFIELD ON EACH LOT. THE SITE EVALUATOR (LICENSE NUMBER 05 12238) HAS EVALUATED THE SUITABILITY OF THE SUBDIVISION SITE FOR OSSF AND SUBMITTED A REPORT CONCLUDING THAT THE SITE IS SUITABLE FOR OSSF. THE REPORT WAS REVIEWED AND APPROVED BY THE HIDALGO COUNTY HEALTH DEPARTMENT. HIGHLIGHTS OF THE REPORT ARE AS FOLLOWS: AND THE DRAINAGE EASEMENTS.

EACH LOT IN THE PROPOSED SUBDIVISION IS AT LEAST 1/2 ACRE IN SIZE THE UNITED STATES DEPT. OF AGRICULTURE SOIL CONSERVATION SERVICE SOIL SURVEY BOOK INDICATED A SANDY CLAY LOAM, CLAY LOAM AND FINE CLAY LOAM. THE SITE EVALUATOR (LICENSE NUMBER 05 12238) HAS TBN (110) TEST BORINGS MADE AT OPPOSITE AREAS OF THE SUBDIVISION AT THE CENTERS OF LOTS 1, 8, 15, 21, 30, 35, 40, 45, 51, AND 57 (ADDITIONAL BORINGS WERE UNDERTAKEN AT THE CENTERS OF LOTS 1, 8, 15, 21, 30, 35, 40, 45, 51, AND 57). (PUEBLOS ADICIONALES NO FUERON NECESARIAS PORQUE EL SUELO ES MUY UNIFORME DENTRO DEL AREA DELIMITADA). EL SUELO ES UNIFORME, DE MARGA AEROSO/CON TEXTURA CLASE II) EXTENDIENDO A MAS DE 24 PULGADAS BAJO EL FONDO DE CUALQUIER EXCAVACION POR EL EVALUADOR (LIC# 05 12238). NO HAY PRESENCIA DE AGUA SUBTERRANEA BAJO LA CAPA DE 24 PULGADAS DE FONDO DE LAS EXCAVACIONES.

EL COSTO TOTAL PARA LA INSTALACION DE UN SISTEMA INDIVIDUAL DE FOSAS SEPTICAS POR SOLAR SON US\$ 1850.00, INCLUYENDO EL COSTO DEL PERMISO REQUERIDO Y LICENCIA. EN ESTOS MOMENTOS TODAS LAS FOSAS SEPTICAS HAN SI INSTALADAS EN EL PROCESO DE LA APROBACION FINAL. A UN COSTO TOTAL DE US\$ 95,750.00, EL DEPARTAMENTO DE SALUBRIDAD DEL CONDADO DE HIDALGO HA INSPECCIONADO TODOS LAS FOSAS SEPTICAS Y AH APROBADO LA INSTALACION DE LAS FOSAS SEPTICAS DESDE EL 12 DE NOVIEMBRE DE 2014.

CERTIFICATION:

BY MY SIGNATURE BELOW, I CERTIFY THAT THE WATER AND SEWAGE SERVICE FACILITIES DESCRIBED ABOVE ARE IN COMPLIANCE WITH THE MODEL RULES ADOPTED UNDER SECTION 16.343 WATER CODE. I CERTIFY THAT THE ESTIMATED COSTS TO INSTALL UNCONSTRUCTED WATER AND ON-SITE SEWAGE FACILITIES DISCUSSED ABOVE, ARE AS FOLLOWS:

WATER FACILITIES- THESE FACILITIES WILL BE FULLY CONSTRUCTED, WITH THE INSTALLATION OF WATER METERS, WILL COST A GRAND TOTAL OF \$ WHICH EQUALS TO \$ PER LOT.

SEWAGE FACILITIES- SEPTIC SYSTEM IS ESTIMATED TO COST \$ 1850.00 PER LOT (ALL INCLUSIVE), FOR A TOTAL OF \$ 95,750.00 FOR THE ENTIRE SUBDIVISION.



Alfonso Quintanilla
ALFONSO QUINTANILLA
P.E. No. 95534
5-7-2020
DATE

SUBDIVIDER CERTIFICATION

1.- BY COMPLETING THE IMPROVEMENTS DESCRIBED ON THE PLAT, SUBDIVIDER WILL COMPLY WITH MINIMUM STATE STANDARDS AND THAT (a) WATER QUALITY AND CONNECTIONS INCLUDING WATER METERS TO THE LOTS MEET SUCH STANDARDS AND (b) SEWER CONNECTIONS TO THE LOTS OR SEPTIC TANKS MEET OR WILL MEET SUCH STANDARDS AND WILL BE BY STATE AND COUNTY REGULATIONS.

SUBDIVIDER STATEMENT:

GIRASOL DEVELOPMENT GROUP, LLC
BY, RICHARD W. RUPPERT SUBDIVIDERS OF SUNSHINE ESTATES No. 1 HEREBY CERTIFY SEWER PERMITS ARE REQUIRED PRIOR TO BUILDING ON ANY LOT AND THAT AN ADEQUATE DRINKING WATER SOURCE IS IMMEDIATELY AVAILABLE TO EACH LOT OF THE TYPE, QUALITY & QUANTITY TO ENABLE EACH PERSON PURCHASING A LOT HAVE ADEQUATE WATER TO COMPLY WITH THE REGULATIONS AND THE LAWS TO THE STATE AS REQUIRED BY STATE AND COUNTY REGULATIONS.

GIRASOL DEVELOPMENT GROUP, LLC
BY, RICHARD W. RUPPERT
2810 N. CLOSNER BLVD.
EDINBURG TX, 78541

STATE OF TEXAS
COUNTY OF HIDALGO

BEFORE ME, the undersigned notary public, on this day personally appeared RICHARD W. RUPPERT, GIRASOL DEVELOPMENT GROUP, LLC proved to me through his Department of Public Safety Driver License to be the person whose name is subscribed to the foregoing instrument, who, being by me first duly sworn, declared that the statements therein are true and correct and acknowledged that he executed the same for the purposes and consideration thereby expressed.

Given under my hand and seal of office this _____ day of _____, 20____.

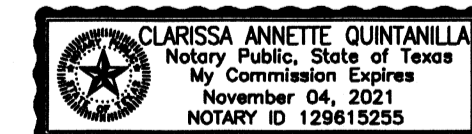

CLARISSA ANNETTE QUINTANILLA - NOTARY PUBLIC

REPORTE FINAL DE INGENIERIA PARA LA SUBDIVISION DE SUNSHINE ESTATES No.

BY ALFONSO QUINTANILLA, P.E.

PROVISION DE AGUA: Descripción, Gastos, y Fecha de Inicio

SUNSHINE ESTATES No. 1, RECIBIRA SU PROVISION DE AGUA DE NORTH ALAMO WATER SUPPLY CORPORATION (LA COMPAÑIA DE AGUA DE NORTH ALAMO) ("N.A.W.S.C."), EL DUEÑO DE LA SUBDIVISION Y LA COMAÑIA N.A.W.S.C. HAN FIRMADO UN CONTRATO POR EL CUAL LA SUBDIVISION RECIBIRA SU PROVISION DE AGUA POR LOS PROXIMOS 30 AÑOS. N.A.W.S.C. TENDRA QUE REPRESENTAR DOCUMENTACION PARA DEMOSTRAR A LARGO PLAZO LA CANTIDAD Y CALIDAD DE AGUA ACCESIBLE PARA SERVIR EL FUTURO DESARROLLO DE LA SUBDIVISION. N.A.W.S.C. TIENE UNA LINEA EXISTENTE DE 8 PULGADAS DE DIAMETRO QUE CORRE POR EL LADO OESTE DE LA CALLE VISTA DRIVE Y UNA LINEA EXISTENTE DE 12" PULGADAS DE DIAMETRO QUE CORRE POR EL LADO NORTE DE AL CALLE MONTE CRISTO ROAD (F.M. 1925).

EL SISTEMA DE AGUA PARA SUNSHINE ESTATES No. 1 CONSISTE DE UNA LINEA DE 8 PULGADAS DE DIAMETRO QUE SE CONECTA CON LA LINEA DE AGUA EXISTENTE DE 12 PULGADAS DE DIAMETRO POR EL LADO NORTE DE LA CALLE MONTE CRISTO ROAD (F.M. 1925) LA LINEA DE 8" DE DIAMETRO CORRE HACIA EL NORTE POR EL LADO OESTE DE LA CALLE JESUS FLORES ROAD, Y VOLTA HACIA EL OESTE POR EL LADO NORTE DE LA CALLE SPOKE 1.7 LANE, VOLTIENDO HACIA EL NORTE POR EL LADO ESTE DE LA CALLE BOWWOOD LANE, NUEVAMENTE VOLTA HACIA EL ESTE POR EL LADO SUR DE LA CALLE CROSSCAMA LANE Y SE VUELVE A CONECTAR CON LA LINEA DE 8 PULGADAS DE DIAMETRO EN LA CALLE JESUS FLORES ROAD. OTRA LINEA DE 8 PULGADAS DE DIAMETRO CORRE POR EL LADO ESTE DE LA CALLE HELICONIA AVENUE Y SE CONECTA CON LA LINEA DE AGUA EXISTENTE DE 12 PULGADAS DE DIAMETRO DE LA CALLE MONTE CRISTO ROAD.

DE LA LINEA PROPUESTA DE 8 PULGADAS DE DIAMETRO VEINTISIS (26) CONDUCTOS DOBLES DE 1 PULGADA DE DIAMETRO, QUE SE DIVIDEN EN DOS LINEAS DE 3/4" PULGADA QUE CORREN HACIA LOS MEDIORES DE AGUA DE LOS LOTES Y SEIS (6) CONDUCTOS INDIVIDUALES DE AGUA DE 3/4" DE PULGADA DE DIAMETRO. SEIS (6) HIDRANTES HAN SIDO INSTALADOS EN TODA LA SUBDIVISION.

LA LINEA DE 8 PULGADAS DE DIAMETRO, LOS SERVICIOS DOBLES DE 1 PULGADA, LOS SERVICIOS INDIVIDUALES DE 3/4" Y LOS CASAS DE MEDIDOR DE AGUA HA SIDO INSTALADO A UN COSTO TOTAL DE US\$ O US\$ POR LOTE. EL DUEÑO DE LA SUBDIVISION HA TAMBIEN PAGADO US\$ O US\$ POR LOTE A N.A.W.S.C. POR COSTO DE LA INSTALACION DE CADA MEDIDOR DE AGUA, MEMBRASAS Y LOS GASTOS DE CONEXION, CUANDO EL DUEÑO DE CADA LOTE SOLICITE UN MEDIDOR DE AGUA. LA COMPAÑIA N.A.W.S.C. LO INSTALARA SIN ALGUN GASTO AL DUEÑO. EL SISTEMA DE AGUA ESTARA EN FUNCIONAMIENTO COMPLETO ANTES O EN LA FECHA, EN LA CUAL LA SUBDIVISION SEA REGISTRADA EN EL CONDADO DE HIDALGO.

DRENAJE: Descripción, Gastos y Fecha de Inicio
EL DRENAJE DE SUNSHINE ESTATES No. 1, TENDRA FOSAS SEPTICAS INDIVIDUALES (OSSF) CONSISTIENDO EN UN DISEÑO NORMAL, CON DOBLE COMPARTIMIENTO DE FOSA SEPTICA (OSSF) Y UN CAMPO DE DRENAJE EN CADA SOLAR. EL EVALUADOR (LIC# 05 12238) DE ENJUICE HA INSPECCIONADO, EVALUADO Y REPORTADO QUE LA UBICACION DE LA SUBDIVISION ES CONVENIENTE PARA FOSAS SEPTICAS (OSSF). EL REPORTE FUE EXAMINADO Y APROBADO POR EL DEPARTAMENTO DE SALUD DEL CONDADO DE HIDALGO.

CADA SOLAR EN LA SUBDIVISION MIDE MEDIO ACRE DE TAMAÑO. EL LIBRO DE SERVICIOS Y CONSERVACION DEL SUELO DEL DEPARTAMENTO DE AGRICULTURA DE LOS ESTADOS UNIDOS (USDA) INDICA UNA MEZCLA DE MARGA DE BARRO Y AEROSO, MARGA DE AEROSO Y UN MARGA FINO DE BARRO. EL EVALUADOR (LIC# 05 12238) HIZO VEZ (10) PRUEBAS CON AGUJEROS EN EL CENTRO DE LOS LOTES 1, 8, 15, 21, 30, 35, 40, 45, 51, Y 57. (PUEBLOS ADICIONALES NO FUERON NECESARIAS PORQUE EL SUELO ES MUY UNIFORME DENTRO DEL AREA DELIMITADA). EL SUELO ES UNIFORME, DE MARGA AEROSO/CON TEXTURA CLASE II) EXTENDIENDO A MAS DE 24 PULGADAS BAJO EL FONDO DE CUALQUIER EXCAVACION POR EL EVALUADOR (LIC# 05 12238). NO HAY PRESENCIA DE AGUA SUBTERRANEA BAJO LA CAPA DE 24 PULGADAS DE FONDO DE LAS EXCAVACIONES.

EL COSTO TOTAL PARA LA INSTALACION DE UN SISTEMA INDIVIDUAL DE FOSAS SEPTICAS POR SOLAR SON US\$ 1850.00, INCLUYENDO EL COSTO DEL PERMISO REQUERIDO Y LICENCIA. EN ESTOS MOMENTOS TODAS LAS FOSAS SEPTICAS HAN SI INSTALADAS EN EL PROCESO DE LA APROBACION FINAL. A UN COSTO TOTAL DE US\$ 95,750.00, EL DEPARTAMENTO DE SALUBRIDAD DEL CONDADO DE HIDALGO HA INSPECCIONADO TODOS LAS FOSAS SEPTICAS Y AH APROBADO LA INSTALACION DE LAS FOSAS SEPTICAS DESDE EL 12 DE NOVIEMBRE DE 2014.

CERTIFICACION:

CON MI FIRMA, CERTIFICO QUE LOS SERVICIOS Y SISTEMAS DE AGUA Y DE DRENAJE, DESCRITOS EN ESTE DOCUMENTO, CUMPLEN CON LAS MODEL SUBDIVISION RULES (LAS REGLAS GOBERNANDO A LAS SUBDIVISIONES), ADOPTADAS EN LA SECCION 16.343 DEL TEXAS WATER CODE (CODIGO DE AGUA DE TEXAS). CERTIFICO QUE LOS GASTOS PARA INSTALAR LOS SISTEMAS DE AGUA Y DE DRENAJE SON:

AGUA: EL SISTEMA/SERVICIO DE AGUA SERA INSTALADO Y COMPLETAMENTE CONSTRUIDO MENOS EL MEDIDOR MECANICO DE AGUA QUE COSTARA UN TOTAL DE US\$ O US\$ POR LOTE.

DRENAJE: SE ESTIMA QUE LA FOSAS SEPTICAS COSTARON US\$ 1850.00 POR LOTE A UN COSTO TOTAL DE US\$ 95,750.00 PARA TODA LA SUBDIVISION.



Alfonso Quintanilla
ALFONSO QUINTANILLA
P.E. No. 95534
5-7-2020
DATE

COST ESTIMATE

WATER DISTRIBUTION: \$
DRAINAGE IMPROVEMENTS: \$
PAVING IMPROVEMENTS: \$
SEPTIC TANK (OSSF): \$

CONCRETE SCHOOL BUS STOP PICKUP AREA

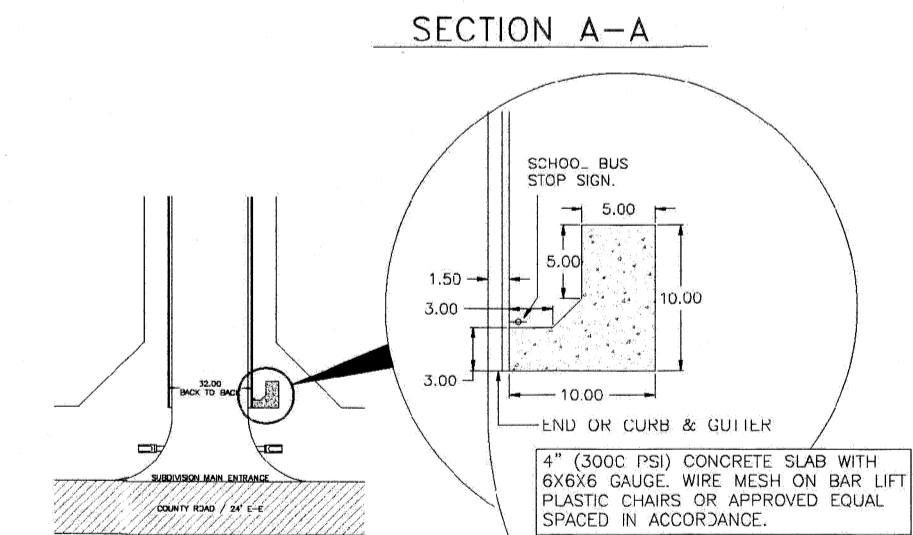
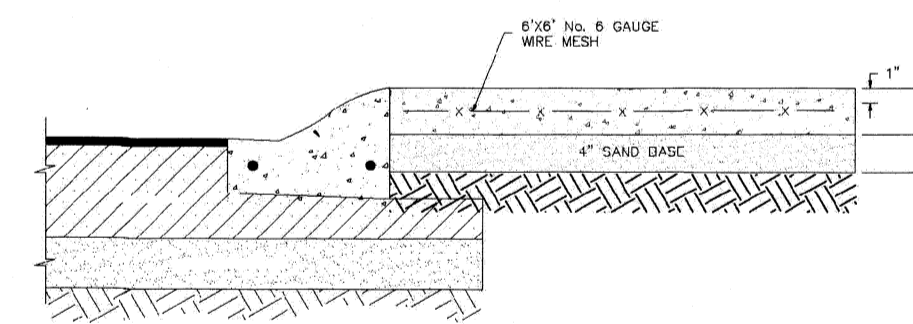

REVISION NOTES				
No.	Sheet	REVISION	Date	Approved

DRAINAGE REPORT FOR SUNSHINE ESTATES No. 1

A 67.52 acre tract of land out of Lots 15 and 16, Block 96, Missouri-Texas Land and Irrigation Company's Subdivision, Hidalgo County, Texas, according to the plat or map thereof recorded in volume 1, page 29, map records Hidalgo County, Texas, and according to warranty deed with vendor's lien recorded under county clerk's document number 3061165, official records, Hidalgo County, Texas. It is located on the northwest corner of Monte Cristo Road (F.M. 1925) and Jesus Flores Road and in the rural part of Hidalgo County. The proposed subdivision will consist of 58 residential lots.

The tract is Zone "X" (No shading), areas determined to be outside 500-year floodplain, as per FEMA Flood Insurance Rate Map, Community Panel No. 480334 0350 C, dated on June 6, 2000 with LOMR dated May 17, 2001.

The majority of the soil is Hargill (17), Hidalgo (25 & 28) and Wilacy (70) and is in soil group "B". It is fine sandy loam, (SM-SC), sandy clay loam (SC) and clay loam (CL). This soil is well drained. Permeability is moderate. Plasticity Index has a range of 0-23. See attached Soil Survey of Hidalgo County, Texas tables.

Presently, the site has very minimal runoff in a westerly direction with an approximate 1% slope. The proposed subdivision is Q= 17.66 cubic feet per second based on a 10-year storm.

After development the runoff will be Q= 58.24 cubic feet per second based on a 50-year storm for an increase of Q=40.58 cubic feet per second. Detention will be 193,024.69 cubic feet (4.43-acre feet) and will be accomplished by excavating the existing Engelman Irrigation District Drain Ditch located on the west side of the subdivision, 60.00' of H.C.D.D. No. 1 Drain Ditch Right of Way is being dedicated by this plat. The existing Engelman Irrigation District Drain Ditch flows north about 1,000 feet and connects with H.C.D.D. No. 1 - South Main Drain. The street runoff will be collected by a storm sewer system consisting of 18", 24" and 30" pipes and Type "CC" inlets that will discharge into the new drain ditch.

CERTIFICATION:

BY MY SIGNATURE BELOW, I CERTIFY THAT THE 100-YEAR FLOODPLAIN FOR ZONE "X" AS DESCRIBED IN COMMUNITY PANEL NUMBER 480334 0350 C, IS MAP REVISED: NOVEMBER 16, 1982 (LOMR DATE MAY 17, 2001) CONTAINED WITHIN THE DRAINAGE OF THE SUBDIVISION, AS SHOWN BELOW.



Alfonso Quintanilla
ALFONSO QUINTANILLA
P.E. No. 95534
5-7-2020
DATE

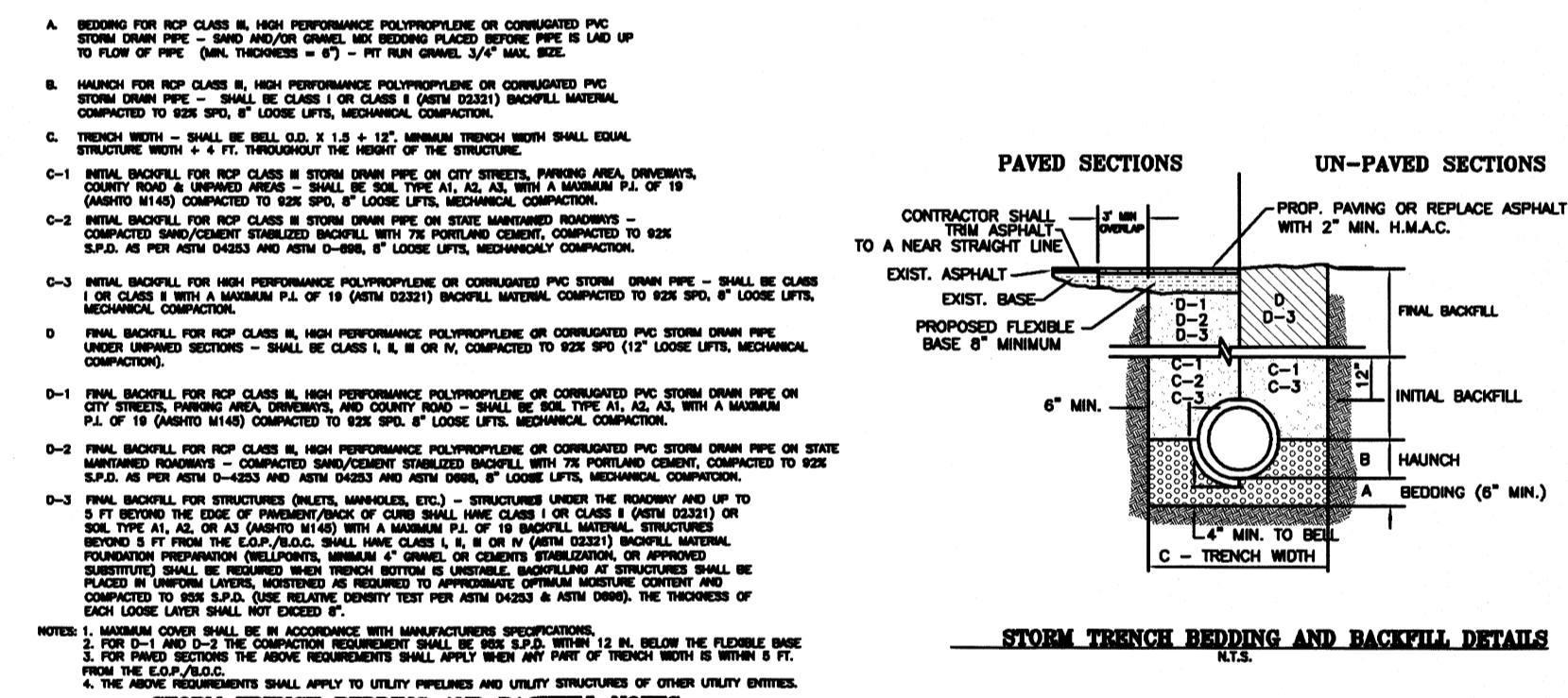

STORM TRENCH BEDDING AND BACKFILL NOTES

REVISION NOTES				
No.	Sheet	REVISION	Date	Approved



FILED FOR RECORD IN
HIDALGO COUNTY
ARTURO GUAJARDO, JR.
HIDALGO COUNTY CLERK

ON: _____ AT _____ AM/PM
INSTRUMENT NUMBER _____
OF THE MAP RECORDS OF HIDALGO COUNTY, TEXAS

BY: _____ DEPUTY

SHEET NO. 5 OF 5 SHEETS	FILENAME : F:\DATA\SUBDIVISIONS\HIDALGO CO.\SUNSHINE ESTATES No. 1 VB-PLAT			
	DATE PREPARED	PREPARED BY	CHECKED BY	APPROVED BY
	5-11-2020	JS		
	DATE REVISION		CHECKED BY	APPROVED BY

QUINTANILLA, HEADLEY AND ASSOCIATES, INC.
CONSULTING ENGINEERS • LAND SURVEYORS
124 E. STUBBS ST. PHONE 956-381-6480
EDINBURG, TEXAS 78539 FAX 956-381-0527
ENGINEERING REGISTRATION NUMBER F-1513 ALFONSO@QHA-ENG.COM
SURVEYING REGISTRATION NUMBER 100411-00