

the **Architect** agrees to perform professional Architecture services in connection with the **Project** as stated in the articles to follow and for having rendered such services, the **County** agrees to pay the **Architect** compensation as stated in the articles to follow.

ARTICLE 2. Character and Extent of Services. This Agreement will provide for the development of the **Project** with the following:

2.1 Scope of Work. The **County** will furnish items and provide those services for the development of the **Project** and fulfillment of this Agreement, as identified in **EXHIBIT “A” Services to be Provided by the County**, attached hereto and made a part of this Agreement as identified in **EXHIBIT “B”- Services to Provided by the Architect**, attached hereto and made a part of this agreement.

2.2 Classification of Services For this Agreement, the professional services to be provided by the **Architect**, as more particularly identified in **EXHIBIT “B”**, attached hereto.

2.3 Schedule of Work. The **Architect** shall prepare a schedule of work (hereinafter referred to as “**Work Schedule**”) in accordance with the terms identified in **EXHIBIT “C” - Work Schedule**, attached hereto and made a part of this Agreement exchange for such services.

2.4 Non-Exclusive Services of Architect Hidalgo County reserves the right to request these services from other sources other than the **Architect** and shall not be in violation of any terms or conditions of this Agreement.

ARTICLE 3. Period of Service. Upon execution of this Agreement, the **Architect** shall proceed with the work outlined under Article 2 hereof.

3.1 Termination Date. This Agreement shall **expire upon completion, Commencing, July 28th, 2020, Expiring upon completion;** (hereinafter referred to as the (“**Termination Date**”), unless extended by written supplemental agreement, as provided in Article 8 hereof, duly executed by the **Architect** and the **County** prior to the **Termination Date**, or otherwise terminated as provided in Article 3.4 herein and below.. The **County** assumes no liability or obligation for payment

to the **Architect** for work performed or costs incurred by the **Architect** prior to the date authorized by the **County** for the **Architect** to begin work, during periods when work is suspended, or subsequent to the **Termination Date**.

3.2 Extension of the Termination Date. The **Architect** shall notify the **County** in writing as soon as possible if it is determined, or reasonably anticipated, that the work under this Agreement cannot be completed before the **Termination Date**, and the **County** may, at the **County's** sole discretion, extend the **Termination Date** by written supplemental agreement as provided in Article 8 hereof. The **Architect** shall allow adequate time for review and approval by the **County** of the written notice and request by the **Architect** to extend the **Termination Date**.

3.3 Suspension of Work. Should the **County** desire to suspend the work under this Agreement, but not terminate this Agreement, the **County** shall provide thirty (30) calendar days verbal notification to the **Architect**, followed by written confirmation from the **County** to the **Architect** to that effect. The thirty-day notice may be waived as agreed in writing by both the **County** and the **Architect**. The work under this Agreement may be reinstated and resumed in full force and effect within sixty (60) days of receipt of written notice from the **County** to the **Architect**. The sixty-day notice may be waived as agreed in writing by both the **County** and the **Architect**.

If the **County** suspends the work, the **Termination Date** as identified above is not affected, and this Agreement will terminate on the date specified, unless extended by written supplemental agreement, as provided in Article 8 hereof, duly executed by the **Architect** and the **County** prior to the **Termination Date**.

3.4 Termination of Agreement. This Agreement may be terminated before the stated **Termination Date** identified in Article 3.1 herein by any of the following conditions:

- (1) **Commitment of Current Revenues.** In the event that, during any term hereof, the **County** does not appropriate sufficient funds to meet to the obligations of this Agreement, the **County** may terminate this Agreement upon thirty (30) days written notice to the **Architect**. The **County** agrees, however, to use reasonable efforts to secure funds necessary for the continued performance of this Agreement. The parties intend this provision to be a continuing right to

terminate this Agreement at the expiration of each budget period of the **County** pursuant to the provisions of Tex. Loc. Govt. Code Ann. ' 271.903 (Vernon Supp. 1995).

- (2) By mutual agreement and consent, in writing, of both the **Architect** and the **County**.
- (3) By the **County**, upon failure of the **Architect** to fulfill the **Architect's** obligations set forth herein in a satisfactory manner as determined by the **County** and in sole opinion of the **County**, after the **County** provides written notice to the **Architect** of such failure and the **Architect** has not corrected such failure within (30) days of such written notice by the **Architect**.
- (4) By the **Architect**, upon failure of the **County** to fulfill the **Architect's** obligations set forth herein, after the **Architect** provides written notice to the **County** of such failure and the **County** has not corrected such failure within thirty (30) days of such written notice by the **Architect**.
- (5) By the **County** without cause upon thirty (30) days written notice to the **Architect**.
- (6) By satisfactory completion of all services and obligations described herein.

Should the **Architect** terminate this Agreement as herein provided, no fees other than fees due and payable at the time of termination shall thereafter be paid to the **Architect** notwithstanding anything herein to the contrary. In determining the value of the work performed by the **Architect** prior to termination, the **County** shall be the sole judge of the value of such work performed. Compensation for work at termination will be based on a percentage of the work completed at that time. Should the **County** terminate this Agreement under (5) of the paragraph above, the amount charged during the thirty (30) day notice period shall not exceed the amount charged during the preceding ninety (90) days.

If the termination of this Agreement is due to the failure of the **Architect** to fulfill the **Architect's** obligations under this Agreement, the **County** may take over the Project and prosecute the work to completion. In such case, the **Architect** shall be liable to the **County** for any additional cost occasioned by the **County**.

If the **Architect** defaults in the performance of this Agreement or if the **County** terminates this Agreement for fault on the part of the **Architect**, the **County** will give consideration to payment of an amount in settlement to include: the actual costs incurred by the **Architect** in performing the work to the date of default, the amount of work required which was satisfactorily completed to date of default,

the value of the work which is usable to the **County**, the cost to the **County** of employing another consultant and/or firm to complete the work required and the time required to do so, and other factors which affect the value to the **County** of the work performed at the time of default. This Agreement shall not be considered as specifying the exclusive remedy for any default by the **Architect**, but all remedies existing at law and in equity may be availed of by either party and shall be cumulative.

The termination of the Agreement and payment of an amount in settlement as prescribed above shall extinguish all rights, duties, and obligations of the **County** and the **Architect** under this Agreement, except the obligations set forth in Articles 11.2, 12, 13, 15, 16, 17, 18.3, 19, 22 and 26 hereto.

ARTICLE 4. Progress and Coordination. The **Architect** shall, from time to time during the progress of the work, confer with the **County**. The **Architect** shall prepare and present such information as may be pertinent and necessary, or as may be requested by the **County**, in order to evaluate features of the **Architect's** services and work.

At the request of the **County** or the **Architect**, conferences shall be provided at the **Architect's** office, the office of the **County**, or at other locations designated by the **County**. These conferences shall also include evaluation of the **Architect's** services and work when requested by the **County**.

All applicable study reports shall be submitted in preliminary form for approval by the **County** before the final report is issued. The **County's** comments regarding the **Architect's** preliminary report will be addressed by the **Architect** in the final report.

If funds by other agencies or entities are to be used for the development of the project under this Agreement, the **Architect's** services and work will be subject to periodic review and approval by other agencies or entities, including those of the city, county, state and/or federal agencies.

Should it be determined that the progress in the production of the **Architect's** services and work does not satisfy the requirements of the approved **Work Schedule** as provided by **Exhibit "C"**, attached hereto, the **County** shall review the approved **Work Schedule** with the **Architect** to determine the corrective action needed by either the **County** or the **Architect**.

The **Architect** shall promptly advise the **County** in writing of events which have a significant

impact upon the progress of the **Architect's** services and work and the approved **Work Schedule**, including:

- (1) problems, delays, adverse conditions which will materially affect the ability to attain contract objectives, prevent the meeting of time schedules and goals, or preclude the timely completion and submittal of **Project** deliverables by the **Architect** within established time periods; this disclosure will be accompanied by a statement by the **Architect** of recommended or immediate action taken, or contemplated, and any **County** or other agency or entity assistance needed to resolve the situation: and
- (2) favorable developments or events which enable meeting the **Work Schedule** goals sooner than anticipated.

ARTICLE 5. Compensation and Fees. For and in consideration of the services to be rendered by the **Architect**, the **County** shall compensate the **Architect** as follows:

5.1 Services. For and in consideration of the **Services** to be rendered by the **Architect**, as identified in Article 2 and more particularly identified in **EXHIBIT "B"**, attached hereto, the maximum amount payable by the **County** to the **Architect** for **Services**, subject to adjustment in accordance with Article 6.1 herein, will be provided in the Scope of Services to be provided by the Architect (**Exhibit "B"**). An outline and breakdown of the **Services Fee** is more particularly identified in **EXHIBIT "D"-Architect Contract Rates**, attached hereto and made a part of this Agreement. Payments to the **Architect** for **Services** shall be made by the **County**, upon presentation by the **Architect** of the monthly **Request for Payment**, in accordance with the terms and provisions of Article 6 herein.

5.2 Special Services. Those services that may be required to be provided by the **Architect** as **Special Services** are set forth below and more particularly described in **EXHIBIT "B"**, attached hereto. For and in consideration of these **Special Services** rendered as required by the **Architect**, the **County** shall pay the **Architect** a negotiated lump sum fee (hereafter referred to as "**Special Services Fee**") at the hourly labor rates and non-labor rates (hereinafter referred to as "**Contract Rates**") specified in **EXHIBIT "D" - Contract Rates**, attached hereto and made a part of this Agreement, and as follows:

- I. RESIDENT OR SITE ARCHITECT, INSPECTOR.** Actual performance of services of project site **Architect**, resident Architect and/or inspector, if required by **County**.
- 2. DOCUMENT COPIES.** Actual performance and/or providing of additional copies (over

10) of report; additional copies (over 10) of plans (contract drawings), specifications and estimates (PS&E); additional copies (over 10) of bidding documents: additional copies (over 10) of as-built drawings.

3. EXTRA TRAVEL. Extra travel required of **Architect** and authorized by **County** to points outside of Hidalgo County.

4. EXPERT WITNESS. Assistance to the **County** as expert witness in any litigation with third parties, arising from the development or construction of the **Project**.

5. MISCELLANEOUS. Investigations involving detailed consideration of operation, maintenance and overhead expenses and (unless otherwise agreed) the preparation of rate schedules, earning and expense statements; preparation of feasibility studies; environmental document preparation; appraisals, valuations, and material audits; or inventories required for certification of force account construction performed by the **County**; preparation of change orders for extra work done by the **Contractor**.

ARTICLE 6. Method of Payment.

6.1 Request for Payment. Payments to the **Architect** for services rendered will be made while work is in progress as executed through a lump sum fee assigned to each **Scope of Services provided by the Architect** (hereinafter referred to as “**Scope of Services provided by the Architect**”) in accordance with Article 7 herein. For the **Scope of Services provided by the Architect**, the **Architect** shall prepare and submit to the **County** monthly progress reports in sufficient detail to support the progress of the work and in support of a request for payment (hereinafter referred to as “**Request for Payment**”). The progress report shall indicate the percent completion of the work accomplished by the **Architect** during the billing period and to the date of the **Request for Payment**. On or before noon of the first Monday of each month during the performance of the services, the **Architect** shall submit to the **County** for approval a **Request for Payment**. Payment of the lump sum fee for the **Scope of Services provided by the Architect** identified in the **Request for Payment** will be in proportion to the percent completion of the work tasks identified in such **Scope of Services provided by the Architect** together with a detailed breakdown of the amount and the sum of all prior payments. The **County** shall review each such **Request for Payment** and may make such exceptions as the **County** reasonably deems necessary or appropriate under the circumstances then existing. About ten (10) working days after the Commissioners Court of the **County** meets approving such payment, the **County** shall make payment to the **Architect** in the amount approved as aforesaid subject to Article 6.4 herein and below.

If the **Project**, or any portion(s) thereof, are deleted or otherwise not constructed, compensation to the **Architect** by the **County** for the **Project** or such portions of the project shall be only the amounts paid the **Architect** for actual work performed in accordance with the **Scope of Services provided by the Architect** (s) approved by the **County**.

6.2 Final Payment. After final completion of the work and acceptance thereof by the **County**, the **Architect** shall submit a final request for payment ("**Final Request for Payment**") which shall set forth all amounts due and remaining unpaid to the **Architect** and upon approval thereof by the **County**, the **County** shall pay to the **Architect** the amount due ("**Final Payment**") under such **Final Request for Payment** in accordance with the provisions of Article 6.1, hereof. The **Final Payment** shall not be made until the **Architect** delivers to the **County** an affidavit that so far as the **Architect** has knowledge or information any and all amounts due for materials and services over which the **Architect** has control have been paid.

6.3 Qualification on Obligations to Pay. Any provision hereof to the contrary notwithstanding, the **County** shall not be obligated to make any payment (whether a payment under Article 6.1 hereof or **Final Payment**) to the **Architect** hereunder if any one or more of the following conditions precedent exist:

- (1) The **Architect** is in default of any of its obligations hereunder or otherwise is in default under this Agreement or under any contract documents related to this Agreement;
- (2) Any part of such payment is attributable to the **Architect's** services which are not performed in accordance with this Agreement; provided, however, such payment shall be made as to the part thereof attributable to the **Architect's** services which were performed in accordance with this Agreement.
- (3) The **Architect** has failed to make payments promptly to consultants or other third parties used in connection with the **Project** for which the **County** has made payment to the **Architect**;
- (4) If the **County**, in good faith judgment, determines that the portion of the compensation then remaining unpaid will not be sufficient to complete the **Architect's** services in accordance with this Agreement, no additional payments will be due the **Architect** hereunder unless and until the **Architect**, at its sole cost, performs a sufficient portion of the **Architect's** services so that such portion of the compensation then remaining unpaid is determined by the **County** to be sufficient to so complete the **Architect's** services.

6.4 No partial payment made hereunder shall be or construed to be final acceptance or approval of that part of the **Architect's** services to which such partial payment related or relieves the

Architect of any of its obligations hereunder with respect thereto.

6.5 The **Architect** shall promptly pay all bills for labor and material performed and furnished by others in connection with the performance of the **Architect's** services.

6.6 Waiver. The making of the **Final Payment** shall constitute a waiver of all claims by the **County** except those arising from (1) faulty or defective services of the **Architect** appearing after completion of the **Project**. (2) failure of the **Architect's** services to comply with the requirements of this Agreement or any contracts or Agreements related to the **Project**, or (3) terms of any special warranties required by this Agreement or provided at law or in equity. The acceptance of **Final Payment** shall constitute a waiver of all claims by the **Architect** except those previously made in writing and identified by the **Architect** as unsettled at the time of the **Final Request for Payment**.

ARTICLE 7. Scope of Services provided by the Architect. After execution of this Agreement, the **Architect** shall proceed with the work outlined under Article 2 hereof. The **Architect** will identify, as approved by the **County**, the needed services for the **Project**, as required through the course of the development to the **Project**. The **County** shall authorize the **Architect** to perform one or more of the agreed tasks identified in **EXHIBIT "B"**, attached hereto, in the form of **Scope of Services provided by the Architect**. Upon authorization from the **County**, the **Architect** will prepare a **Scope of Services provided by the Architect** document, which will include a description of the work to be performed, including a description of the tasks and milestones, a work schedule, and an estimated cost proposal agreed upon by the **County** and the **Architect**. The estimated cost proposal shall set forth in detail the computation of the cost of each work task, at the hourly rates established and identified in **EXHIBIT "D"**, attached hereto. The **Scope of Services provided by the Architect** shall not waive the **County's** and the **Architect's** responsibilities and obligations established in this Agreement.

The estimated cost proposal for each **Scope of Services provided by the Architect**, developed by the **Architect** and approved by the **County** shall be used by the **County** to appropriate a purchase order for the **Scope of Services provided by the Architect**. Each executed **Scope of Services provided by the Architect** shall become a part of this **Agreement**. Upon satisfactory

completion of the **Scope of Services provided by the Architect**, the **Architect** shall submit the **Project's** deliverables as specified in the executed **Scope of Services provided by the Architect** to the **County** for review and acceptance.

Work included in a **Scope of Services provided by the Architect** shall not begin until the **County** and the **Architect** have signed the **Scope of Services provided by the Architect**. All work must be completed on or before the completion date specified in the **Scope of Services provided by the Architect**, unless extended by written agreement by the **Architect** and the **County**. The **Architect** shall promptly notify the **County** of any event that will affect completion of the **Scope of Services provided by the Architect**. All **Scope of Services provided by the Architect** must be executed and completed by both the **Architect** and the **County** within the period established for this Agreement as specified in Article 3 hereof.

The final acceptance by the **County** of each **Scope of Services provided by the Architect** for the **Project** shall serve as evidence of completion, on the part of the **Architect**, of all services under this Agreement insofar as they pertain to that portion of work on the **Project** identified in the applicable **Scope of Services provided by the Architect**

ARTICLE 8. Supplemental Agreements. The terms of this Agreement may be amended by supplemental agreement if the **County** determines that (1) there is a need to extend the **Termination Date** identified in Article 3.1 hereof, (2) there has been a significant change in the scope, complexity or character of the services to be performed by the **Architect**, and/or (3) for any other reason agreeable to the **County** and the **Architect**.

If determined appropriate by the **County**, additional compensation to the **Architect** for (1), (2) and/or (3) above shall be paid as a negotiated lump sum fee at the **Contract Rates** specified in **EXHIBIT "D"**, attached hereto. The negotiated lump sum fee shall be incorporated into the **Supplemental Agreement**.

Any **Supplemental Agreement** must be executed by both the **Architect** and the **County** prior to the **Termination Date** specified in Article 3 hereof.

It is distinctly understood and agreed that no claim by the **Architect** for additional work, as

identified in Article 9 hereof, or changes or revisions in work, as identified in Article 10 hereof, shall be made by the **Architect** until full execution of the **Supplemental Agreement** and authorization to proceed is granted by the **County**. The **County** reserves the right to withhold payment to the **Architect** pending verification of satisfactory work performed by the **Architect**.

ARTICLE 9. Additional Work. If the **Architect** is of the opinion that any work it has been directed to perform is beyond the scope of this Agreement and constitutes extra work, the **Architect** shall promptly notify the **County** in writing. In the event the **County** finds that such work does constitute extra work, the **County** shall so advise the **Architect** and a written supplemental agreement will be executed between the **County** and the **Architect** as provided herein. The **Architect** shall not perform any proposed additional work or incur any additional cost prior to the execution by both the **Architect** and the **County** of a supplemental agreement. Additional compensation from the **County** to the **Architect** shall be paid as a negotiated lump sum fee at the Contract Rates specified in **EXHIBIT "D"** attached hereto. The negotiated lump sum fee shall be incorporated into the supplemental agreement as specified in Article 8 hereof. The **County** shall not be liable or under any obligation to compensate the **Architect** for work performed or costs incurred by the **Architect** relating to additional work not directly associated with the performance of the work authorized in this Agreement or as amended through supplemental agreement.

ARTICLE 10. Changes or Revisions in Work. If the **County** finds it necessary to request changes to the work, and the changes are within the applications of sound Architecture principles, the **Architect** shall make such revisions if requested and directed by the **County**.

10.1 Preliminary Work. The **Architect** will make, without expense to the **County**, such revisions of any preliminary reports or drawings as may be required to meet the needs of the **County** and the applications of sound Architecture principles.

10.2 Previously Approved or Satisfactorily Completed Work. If the **County** finds it necessary to request the **Architect** to make changes to work previously approved by the **County** or work satisfactorily completed for which the **County** approves or, after a definite plan has been approved by the **County**, if a decision is subsequently made by the **County**, which for proper execution involves extra services and expenses for changes in or additions to the drawings

specifications or other documents, this will be considered as additional work, and compensation from the **County** to the **Architect** will be in accordance with Article 9 hereof.

10.3 Project Delays. If the **Architect** is required to perform additional work due to delays by the imposition of causes not within the **Architect's** control, such as by the re-advertisement of bids or by the delinquency or insolvency of contractors, such work associated with these delays shall be considered additional work, and the **Architect** shall be compensated by the **County** for such extra services and expense in accordance with Article 9 hereof.

10.4 Reduction of Project Cost. Notwithstanding any provision herein to the contrary, in the event it is necessary for the **County** to require changes in the final plan of the **Project** to enable it to reduce the construction cost of the **Project** to an amount within the sum estimated by the **Architect**, the **Architect** will be required to make such revisions or changes. These changes will only be considered additional work by the **Architect**, if the **Architect** previously provided these same changes as options to the **County** at the stage of preliminary work or prior to the approval of the final plan for the **Project**, and the option or options were not selected or approved by the **County** to be incorporated into the final plan of the **Project**. Payment for this additional work will then be made to the **Architect** in accordance with Article 9 hereof. If the **Architect** failed to provide these changes as an option or options to the **County** at the stage of preliminary work or prior to the approval of the final plan of the **Project**, these changes will not be considered additional work and no additional compensation will be made to the **Architect**.

ARTICLE 11. Ownership and Release of Documents.

11.1 Ownership of Documents. Original drawings and specifications are the property of the **Architect** however the **Project** is the property of the **County**, and the **Architect** may not use the drawings and specifications thereof for any purpose not relating to the **Project** with the **County's** consent. The **County** shall be furnished with such reproductions of drawings and specifications as the **County** may reasonably require. Upon completion of the work or any earlier termination of this Agreement under Article 3.4 hereof, the **Architect** will revise drawings to reflect changes made during construction and will promptly furnish the **County** with one complete set of reproducible record prints.

Prints shall be furnished by the **Architect**, as an additional service, at any other time requested by **County**. All such reproductions shall be the property of the **County** who may use them without the **Architect's** permission for any proper purpose relating to the **Project**, including but not limited to additions to or completion of the **Project**. Any additions or revisions by the **County** to a drawing signed, sealed, and dated by a registered professional Architect shall be made in accordance with the Texas Engineering practice Act and the Rules of the State Board of Registration for Professional Engineers.

All documents furnished to the **Architect** by the **County** shall be delivered to the **County** upon completion or termination of this Agreement. The **Architect**, at the **Architect's** own expense, may retain copies of such documents or any other data under this Agreement.

11.2 Release of Documents or Information. Release of information to the public or others regarding the **Project** will be accordance with the Texas Public Information Act.

ARTICLE 12. Discounts, Rebates, Refunds. In connection with procurement services rendered by the **Architect**, if procurement services are required of the **Architect** hereunder, all discounts, rebates and refunds shall accrue to the **County**. For some purchases, the **Architect** may deem that payment within the discount period is not safe; and/or inspection, guarantees, or other considerations may dictate delay. In such cases, the **Architect** shall promptly notify the **County** so that a course of action may be mutually agreed upon by the **County** and the **Architect**.

ARTICLE 13. Records, Accounting, Inspection. The **Architect** shall keep full and detailed records and accounts in a manner approved by the **County**. The **Architect** shall afford the **County's** authorized personnel and independent auditors, if any, full access to the work performed by the **Architect** regarding the **Project** and to all of the **Architect's** books, records, correspondence, instructions, drawings, receipts, vouchers and other documents relating to such work under this Agreement and the **Architect** shall preserve all such records for three (3) years after final payment. The **Architect** shall deliver to the **County** upon completion of such work, a statement of the cost of such work detailed according to the accounting procedure and requirements of the **County**.

ARTICLE 14. Subcontracting and Assignment. The **Architect** shall not assign, subcontract or transfer the **Architect's** interest in this Agreement without the prior written consent of the **County**. The **Architect** shall bind every subconsultant by written subcontract to observe all the terms of this

Agreement to the extent that they may be applicable to each subconsultant. No subcontract relieves the **Architect** of any responsibilities under this Agreement.

The **Architect**, and the **County**, do hereby bind themselves, their successors, executors, administrators and assigns to each other party of this Agreement and to the successors, executors, administrators, and assigns of such other party in respect to all covenants of this contract.

ARTICLE 15. Patents. The **Architect** shall indemnify and save the **County** harmless from all liability for alleged or actual infringement of any patent resulting from the use of apparatus or equipment furnished or designed by the **Architect** or from the use of any process designed by the **Architect** or effected by said apparatus or equipment, and the **Architect** shall indemnify and save the **County** harmless from and against all costs, legal fees, expenses and liabilities incurred in or about any claim of or action for such infringement: provided, however, that the **County** shall promptly transmit to the **Architect** all papers served on the **County** in any suit involving such claim of infringement, and provided further, that the **County** permits the **Architect** to have entire charge and control of the defense of any such suit. If because of actual infringement the use of such apparatus, equipment, or process is enjoined, the **Architect** shall refund the purchase price thereof in proportion to the length of service uncompleted, the life of such apparatus or equipment being assumed as five years. The **Architect** hereby grants to the **County** a non-exclusive, royalty-free license under patents now or hereafter owned by the **Architect** covering any machines, apparatus, processes, articles, or products included in the **Architect's** work hereunder.

ARTICLE 16. Confidential Information, Inventions and Other Restrictions.

16.1 Confidential Information. The **Architect** shall not use in any way, commercial or otherwise, except to the extent required by the proper performance of this Agreement; and shall hold in confidence and not disclose to any person, for any reason or at any time, any information relating to the secret processes, products, compositions, machinery, apparatus or trade secrets of the **County**, or any other confidential information given to the **Architect** by any of the **County's** commissioners, elected officials, employees, or representatives or acquired by the **Architect** during the term of or as a result of this Agreement. Any information not generally available to the public shall be considered secret and confidential for the foregoing purposes; provided, however, that any technical information which was

lawfully in the **Architect's** possession prior to such disclosure to the **Architect** by the **County** or which is or shall lawfully be published or become part of general knowledge from sources other than the **Architect** or which otherwise shall lawfully become available to the **Architect** from a source other than the **County**, shall not be subject to these provisions. All the foregoing stipulations shall apply to such information and work hereunder as well as to any information and ideas originated or developed by the **Architect** in performing such work. Such information may, of course, be disclosed to the proper officials or employees of the **County** if necessary to perform the work hereunder. The **Architect** shall, however, inform each of its employees who receive such information of these restrictions and the **Architect** shall take all reasonable precautions and exert all reasonable efforts to assure conformance with such restrictions by all of its officers, employees, and agents, obtaining from them if necessary, agreements satisfactory to the **County**, effectuating the purposes of this Article.

16.2 Inventions. The **Architect** shall communicate to the **County** at once, and require the **Architect's** employees assigned to this **Project** to communicate to the **County** all inventions and improvements which any of the **Architect's** employees, either alone or in conjunction with any of the **County's** employees may conceive, make or discover during the course of or as a result of work on this **Project** under this or any ensuing agreement with the **County** that relates to the processes, products, compositions, machinery or plants of the **County**, or relating in any way to any of the operations in which the **County** may be obligated to pay to the **Architect** as compensation for services rendered by the **Architect** under contract with the **County**. The **Architect** shall require its employees to execute patent applications and assignments thereof to the **County** or its nominees, and powers of attorney relating thereto for any country the **County** may designate, and shall take all other actions as the **County** may request to maintain and protect such inventions and improvements. The **County** shall pay all costs or charges incurred in protecting such inventions and improvements if the **County** desires to protect them. Before assigning any of the **Architect's** employees to work under any contract with the **County** concerning this **Project**, the **Architect** shall obtain from them agreements satisfactory to **County** complying in all respects with the terms and provisions of this Article.

16.3 The rights and obligations set forth in Article 16 shall survive the performance of this

Agreement, or any termination, discharge or cancellation thereof

ARTICLE 17. Architect's Seal, Responsibility and Warranties.

17.1 Architect's Seal. The **Architect** shall assign a responsible Architect or Architects licensed to practice in the State of Texas, who shall sign, seal and date all appropriate Architecture submissions to the **County** in accordance with the Texas Engineering Practice Act and the Rules of the State Board of Registration for Professional Engineers.

17.2 Architect's Responsibility. The **Architect** shall be responsible for the accuracy of the work for the **Project** and shall promptly make necessary revisions or corrections resulting from errors, omissions, or negligent acts by the **Architect**. No additional compensation will be made to the **Architect** for any necessary revisions or corrections resulting from errors, omissions, or negligent acts by the **Architect**.

The **Architect's** responsibility for all questions arising from design errors and/or omissions will be determined by the **County** or a designee appointed by the **County**. The **Architect** will not be relieved of the responsibility for subsequent correction of any such errors or omissions or for clarification of any ambiguities until after the construction phase of the **Project** has been completed.

17.3 Warranties.

(a) The **Architect** warrants that Architecture design work performed by the **Architect** hereunder shall be in accordance with sound Architecture design practices and in conformance with applicable code and standards established for such work.

(b) Notwithstanding anything to the contrary contained in this Agreement, the **County** and the **Architect** agree and acknowledge that the **County** is entering into this Agreement in reliance on the **Architect's** experience and abilities with respect to performing the **Architect's** services hereunder. The **Architect** accepts the relationship of trust and confidence established between it and the **County** by this Agreement. The **Architect** covenants with the **County** to use the **Architect's** best efforts, skill, judgment and abilities to design the **Project** and to further the interests of the **County** in accordance with the **County's** requirements and procedures, in accordance with all professional standards, and in compliance with all applicable national, federal, state, county and municipal laws, regulations, codes, ordinances, orders and with those of any other body having jurisdiction. If the development of plans,

specifications and estimates (hereinafter referred to as “**PS&E**”) are identified in this Agreement under Article 2 hereof or **EXHIBIT “B”**, attached hereto, as part of the services to be provided by the **Architect** for the **Project**, prior to the commencement of construction, the **Architect** shall certify in writing to the **County** that the **PS&E** for the **Project**, and the improvements when built in accordance therewith, conform to all applicable governmental regulations, statutes and ordinances then in effect. The **Architect** represents covenants and agrees that there are no obligations, commitments or impediments of any kind that will limit or prevent performance of the **Architect’s** services.

(c) The **Architect** represents, covenants and agrees that all of **Architect’s** services to be furnished by the **Architect** under or pursuant to this Agreement from the inception of the Agreement until the **Project** has been fully completed, shall be of the standard and quality which prevail among Architects of similar experience, knowledge, skill and ability engaged in Architecture practice throughout Texas under the same or similar circumstances involving the design and construction of **Project**.

(d) The **Architect** represents, covenants and agrees that the **Architect’s** special talent, training and experience cause the **Architect** to be the prime professional on the **Project**; that because of such talent and training, the **Architect** envisions the construction of the **Project** in its entirety and possesses the special skills which enable the **Architect** to recognize dangerous conditions that a reasonable, prudent Architect having such special skills could anticipate may arise from the proper use of the **Project** after acceptance by **County**; and that the **Architect** recognizes that any commissioners, elected officials, employees and agents of the **County**, plus residents and owners of property within the area affected by the **Project** are within a class of foreseeable persons who will be relying on the project being designed in a professional and safe manner.

(e) If the development of **PS&E** is identified in this Agreement under Article 2 hereof or **EXHIBIT “B”**, attached hereto, as part of the services to be provided by the **Architect** for the **Project**, the **Architect** represents, covenants and agrees that the **PS&E** of the **Project** will be accurate and free from any material errors. The **Architect** additionally represents, covenants and agrees to the following: that the design of the **Project** will conform to its foreseeable use as a **Project** with all the amenities as set forth in any **PS&E** developed by the **Architect** for the **Project**; that the result of such **PS&E**, if built

in accordance therewith, will be suitable for purposes for which the **Project** is designed; and the **Project** will be inspected in a workmanlike, professional manner and will be suitable for the **Project's** intended purpose. The **Architect's** responsibilities as set forth herein shall at no time be in any way diminished by reason of any approval by the **County** of any **PS&E** developed by the **Architect** for the **Project**, nor shall the **Architect** be released from any liability by reason of such approval by the **County**, it being understood that the **County** at all times is ultimately relying upon the **Architect's** skill and knowledge in preparing such **PS&E**.

(f) In connection with the **Architect's** performance of procurement services hereunder, if any, the **Architect** use its best efforts to obtain from all vendors of equipment and materials, fullest possible warranties against defective materials and workmanship for the benefit of the **County**.

ARTICLE 18. Architect's Resources. The **Architect** shall furnish and maintain, at the **Architect's** own expense, office space for the performance of all services, skilled and sufficient personnel, as well as adequate and sufficient equipment to perform the services as required under this Agreement.

18.1 Project Manager. The **Architect** shall provide a manager (**Project Manager**) for the **Project** that is a registered professional Architect in the State of Texas. The **Project** manager shall have such knowledge and experience as will enable that **Project Manager** during the course of the **Project** without prior consent of the **County**. If, due to situations beyond the control of the **Architect**, the **Architect** must change the **Project Manager** prior to the completion and acceptance of the **Project**, the **Architect** will submit a request to change the **Project Manager** to the **County** for approval.

18.2 Employees of the Architect. All employees of the **Architect** shall have such knowledge and experience as will enable them to perform the duties assigned to them and required for the services under this Agreement. Any employee of the **Architect** who, in the opinion of the **County**, is incompetent, or whose conduct becomes detrimental to the work required under this Agreement, shall immediately be removed from association with the **Project** when so instructed by the **County**. The **Architect** certifies that the **Architect** presently has employed sufficient and qualified personnel, and will maintain sufficient and qualified personnel for performance of the services under this

Agreement.

18.3 Documents/Information Exchange The purpose of this Article is to define the required automated resources, format for graphics files, and information exchange pertaining to the **Project**. Taking into consideration that the **County** has a significant investment in the development of the **Project**, there is a need for the **Architect** to provide consistency in document development for information exchange. Consistency in document development for information exchange and production will help facilitate an economically efficient **Project**. Therefore, the **Architect** shall provide the **County** with documents and information in accordance with the special requirement outlined in **EXHIBIT "B"** attached hereto.

ARTICLE 19. Indemnification. To the fullest extent permitted by applicable law, the **Architect** and its agents, partners, subcontractors, and consultants (collectively "**Indemnitors**") shall and do agree to indemnify, and hold harmless the **County**, the **County's** respective directors, elected officials, employees and agents (collectively "**Indemnitors**") from and against all claims, damages, losses, liens, causes of action, suits, judgments and expenses, including attorney fees, of any nature, kind or description (collectively "**Liabilities**") of any person or entity whomsoever arising out of, caused by or resulting from the negligent performance of the **Architect's** services through activities of the **Architect**, its agents, partners, subcontractors and/or consultants performed under this Agreement, and which are caused by or result from error, omission, or negligent act of the **Architect** or of any person employed or contracted by the **Architect** provided that any such **Liabilities** (1) are attributable to bodily injury, personal injury, sickness, disease or death of any person, or to the injury to or destruction of tangible personal property including the loss of use and consequential damages resulting therefrom and (2) are caused in whole or in part by any negligent act or omission of the **Architect**, anyone directly or indirectly employed by the **Architect** or anyone for whose acts the **Architect** may be legally liable. The **Architect** shall also save harmless the **County** from any and all expense, including but not limited to, attorney fees which may be incurred by the **County** in litigation or otherwise resisting said claim or liabilities which may be imposed on the **County** as a result of such activities by the **Architect**, its agents partners, subcontractors and/or consultants. In this connection, it is agreed and understood that the **Architect** shall not be responsible for any portion of the liability proximately caused by the

County's negligence.

ARTICLE 20. Joint and Several Liability. In the event more than one of the **Indemnitors** are connected with an accident or occurrence covered by the indemnification in Article 19 hereof, then each of such **Indemnitors** shall be jointly and severally responsible to the **Indemnitees** for indemnification and the ultimate responsibility among such **Indemnitors** for the loss and expense of any such indemnification shall be settled by separate proceedings and without jeopardy to any **Indemnitee**. The provisions of this Article shall not be construed to eliminate or reduce any other indemnification or right which the **County** or any of the **Indemnitees** has by law.

ARTICLE 21. Insurance. The **Architect** shall obtain and maintain insurance in the limits of liability for each of the types of insurance coverage identified as follows.

- (1) Workers Compensation, endorsed with a waiver of subrogation in favor of the **County** in accordance with the statutory obligations imposed by Workers Compensation or Occupational Disease laws under the Texas Workers Compensation Law ("**Statutory Texas**")
- (2) Commercial General Liability, endorsed with the **County** as an additional insured and endorsed with a waiver of subrogation in favor of the County *all to the extent of the liabilities assumed by the Engineer under Article 19 and Article 20 herein*, in limits of liability not less than one million dollars (**\$1,000,000**) combined single limit each occurrence and in the aggregate for bodily injury and property damage.
- (3) Texas Business Automobile Policy, endorsed with the **County** as an additional insured and endorsed with a waiver of subrogation in favor of the **County** *all to the extent of the liabilities assumed by the Engineer under Article 19 and Article 20 herein*, in limits of liability not less than two hundred fifty thousand dollars (**\$250,000**) each person for bodily injury, five hundred thousand dollars (**\$500,000**) each occurrence for bodily injury, and one hundred thousand dollars (**\$100,000**) each occurrence for property damage.
- (4) Professional Liability in limits of **\$1,000,000** each claim and aggregate.

The **Architect** covenants and agrees to maintain an insurance policy in the minimum limits of liability for each of the types of insurance coverage identified above. The **Architect** shall furnish the **County** with a certificate of insurance (**Hidalgo County Certificate of Insurance**) showing the said policy to be in full force and effect during the period of service, identified in Article 3 hereto, for this Agreement. The completed Hidalgo County Certificate of Insurance shall be attached hereto and identified as **EXHIBIT "G"- Hidalgo County Certificate of Insurance**. The **Architect** will be considered in breach of contract should the **Architect** fail to maintain an insurance policy in the

minimum limits of liability and requirements identified above while performing services for and under this Agreement, and will be subject to default and termination of the Agreement as outlined in Article 3.4 hereto. Additionally, the **Architect** covenants and agrees to use its best efforts to maintain an insurance policy in the minimum limits of liability and requirements identified above until one year following the date of the acceptance of the **Project** by **County**.

ARTICLE 22. Compliance with Laws. The **Architect** shall comply with all applicable Federal, State and local laws, statutes, codes, ordinances, rules and regulations and the orders and decrees of any court, or administrative bodies or tribunals in any manner affecting the performance of this Agreement including, without limitation, workers compensation laws, minimum and maximum salary and wage statutes and regulations and licensing laws and regulations. When required the **Architect** shall furnish the **County** with satisfactory proof of its compliance therewith.

ARTICLE 23. Non-Collusion. The **Architect** warrants that the **Architect** has not employed or retained any company or persons, other than a bona fide employee working solely for the **Architect**, to solicit or secure this Agreement, and that the **Architect** has not paid or agreed to pay any company, Architect or any other person or entity any fee, commission, percentage, brokerage fee, gifts or any other consideration contingent upon or resulting from the award or execution of this Agreement. For breach or violation of this warranty the **County** shall have the right to annul this Agreement without liability or, in the **County's** discretion, to deduct from the *Services Fee*, or otherwise recover, the full amount of each fee, commission, percentage, brokerage fee, gift or contingent fee.

ARTICLE 24. Gratuities. The **County** mandates that employees of the **County** shall not accept any benefits, gifts or favors from any person doing business or who reasonably speaking may do business with the **County** under this Agreement; the only exceptions allowed are ordinary business meals. Any person doing business with or who may reasonably seeking to do business with the **County** under this Agreement may not make any offer of benefits, gifts or favors to **County** employees, except as mentioned herein above. Failure on the part of the **Architect** to adhere to this provision may result in the termination of this Agreement.

ARTICLE 25. Payment of Franchise Tax. The **Architect** hereby certifies that the **Architect** is not delinquent in Texas franchise tax payments, or that the **Architect** is exempt from, or not subject to,

such as tax. A false statement concerning franchise tax status shall constitute grounds for termination of the Agreement at the sole option of the **County**.

ARTICLE 26. Disputes. The **Architect** shall be responsible for the settlement of all contractual and administrative issues arising out of any procurement made by the **Architect** in support of the services under this Agreement.

ARTICLE 27. Severability. In the event any one or more of the provisions contained in this Agreement shall for any reason, be held to be invalid, illegal, or unenforceable in any respect such invalidity, illegality or unenforceability shall not affect any other provision thereof and this Agreement shall be construed as if such invalid, illegal or unenforceable provision had never been contained herein.

ARTICLE 28. Notices. All notices to either party by the other required under this Agreement shall be personally delivered or mailed to such party at the following respective addresses:

COUNTY:
Hidalgo County
100 E. Cano, 2nd, Floor
Edinburg, Texas 78539

ARCHITECT:
Rike, Ogden, Figueroa, Alex
Architects, Inc
1007 Walnut Ave McAllen, Texas, 78501

The Address may be changed by either party by written notice and notice so mailed shall be effective upon mailing.

ARTICLE 29. Miscellaneous Provisions.

(a) This Agreement constitutes the entire Agreement between the **Architect** and the **County** relating to the work herein described and supersedes any prior understanding or written or oral contracts between the parties respecting the subject matter defined herein. There are no previous or contemporary representations or warranties of the **County** or the **Architect** not set forth herein.

(b) Except as specifically provided herein no modification, waiver, termination, rescission, discharge or cancellation of this Agreement or of any terms thereof shall be binding on the **County** unless in writing and executed by an officer or employee of the **County** specifically authorized to do so.

(c) No waiver of any provision of or a default under this Agreement shall affect the right of the

County thereafter to enforce said provision or to exercise any right or remedy in the event of any other default whether or not similar.

(d) No modification, waiver, termination, discharge or cancellation of this Agreement or of any terms thereof shall impair the **County's** right with respect to any liabilities whether or not liquidated of the **Architect** to the **County** theretofore accrued.

(e) All rights and remedies of the **County** specified in this Agreement are in addition to the **County's** other rights and remedies.

(f) The **Architect** shall remain an independent contractor and shall have no power nor shall the **Architect** represent that the **Architect** has any power to bind the **County** or to assume or to create any obligation express or implied on behalf of the **County** except as specifically authorized in advance by the **County**.

(g) The Agreement shall be construed under the laws of the State of Texas and is performable in Hidalgo County, Texas.

(h) This Agreement may only be amended by a written document executed by the **County** and the **Architect** as provided by Article 8 herein.

ARTICLE 30. Signatory Warranty The undersigned signatory or signatories for the **Architect** hereby represent and warrant that the signatory is an officer of the organization for which he or she has executed this Agreement and that he or she has full and complete authority to enter into this Agreement on behalf of the **Architect**. The above-stated representations and warranties are made for the purpose of inducing the **County** to enter into this Agreement.

ARTICLE 31. Commitment of Current Revenues Only. In the event that, during any term hereof, the Commissioners Court does not appropriate sufficient funds to meet the obligations of County under this Agreement, County may terminate this Agreement upon thirty (30) days written notice to Architect. County agrees, however, to use reasonable efforts to secure funds necessary for the continued performance of this Agreement. The parties intend this provision to be a continuing

right to terminate this Agreement at the expiration of each budget period of County. **Agreements for the acquisition, including the lease of real or personal property under Tex.Loc.Govt.Code §271.903:** In the event that during any term hereof the Commissioner's Court does not appropriate sufficient funds to meet the obligations of County under this agreement, County may terminate the Agreement upon thirty (30) days written notice to Architect. County agrees, however, to use a best efforts attempt to obtain and appropriate funds for payment of the Agreement. The parties intend this provision, if applicable, to be a continuing right to terminate this Agreement at the expiration of each budget period of County in accordance with Tex. Loc. Govt. Code §271.903 (Vernon Supp. 1966).

ARTICLE 32. Entire Agreement. This Contract contains the entire contract between the parties hereto, and each party acknowledges that neither has made (either directly or through any agent or representative) any representation or agreement in connection with this Contract not specifically set forth herein. This Contract may be modified or amended only by an agreement in writing executed by the parties hereto, and not otherwise.

ARTICLE 33. Immunities. Nothing in this Contract is intended to and County does not hereby waive, release or relinquish any right to assert any of the defenses County enjoys by virtue of the state or federal constitution, laws, rules or regulations, and any sovereign, official or qualified immunity available to County as to any claim or action of any person, entity, or individual against County.

ARTICLE 34. Nondiscrimination: Company, including subcontractors, assignees and successors in interest, ensures that no person shall on the grounds of race, religion, color, national origin, sex, age, or disability, or any other protected class under law, be excluded from participation in, be denied the benefits of, or be otherwise subjected to discrimination or retaliation in any federally or non- federally funded program or activity when providing any services described herein under this contract/Contract. Applicable nondiscrimination statements and provisions of Title

VI of the Civil Rights Act of 1964, as amended, were provided as part of the initial procurement packet and are incorporated herein and made part of this agreement for all purposes.

ARTICLE 35. Additional Documents: The parties hereto covenant and agree that they will execute each such other and further instruments and documents as are or may become necessary or convenient to effectuate and carry out the terms of this Agreement.

ARTICLE 36. Required Contract Provision for Contracts Subject to Federal Award (if applicable): Pursuant to 2 CFR 200.236, a non-federal entity's contracts must contain the applicable provisions described in appendix II to 2 CFR 200-Contract Provisions for non-Federal Entity Contracts under Federal Awards. Additionally, County contracts under Federal award which are subject to assistance from the Federal Emergency Management Agency (FEMA) are also required to contain additional contract clauses. The applicable required contract clauses were provided as part of the initial procurement packet and are incorporated herein and made part of this agreement for all purposes.

ARTICLE 37. Texas Law to Apply. This Agreement shall be construed under and in accordance with the laws of the State of Texas, and all obligations of the parties created hereunder are performable in Hidalgo County, Texas. The parties hereby consent to personal jurisdiction in Hidalgo County, Texas.

WITNESS WHEREOF, the **ARCHITECT** and the **COUNTY** have caused this **Agreement for Professional Services** to be effective as of the 28th day of July , 2020.

ARCHITECT:
Rike, Ogden, Figueroa, Alex, Architects, Inc.,

BY: _____
(Authorized Agent For, Rike, Ogden,
Figueroa, Alex Architects, Inc.,)

COUNTY:
HIDALGO COUNTY

BY: _____
Richard Cortez, County Judge

ATTEST:

BY: _____
Arturo Guajardo, Jr., County Clerk

Approved by Commissioner's Court on _____, 2020.

APPROVED AS TO FORM
Office of the Criminal District Attorney-Civil Litigation Division

By: _____
Victor Garza
Assistant District Attorney

ATTACHMENTS:
EXHIBIT A -Scope of Services to be provided by the County
EXHIBIT B -Scope of Services to be provided by the Architect
EXHIBIT C -Work Schedule
EXHIBIT D -Architect's Rates
EXHIBIT G -Certificate of Insurance (*Hidalgo County*)

EXHIBIT A-1

-Request for Qualifications (RFQ) Procurement Packet

EXHIBIT A

-Scope of Services to be provided by the County

The following provides an outline of the services to be provided by the **COUNTY** in the development of the Project.

The **COUNTY** will provide to the **ARCHITECT** the following:

- (1) Authorization to the **ARCHITECT** to begin work in accordance with Section 3 of this Agreement.
- (2) Payment for work performed by the **ARCHITECT** and accepted by the **COUNTY** in accordance with Section 6 of the Agreement.
- (3) Assistance to the **ARCHITECT**, as necessary, to obtain the required data and information from other local, regional, State and Federal agencies that the **ARCHITECT** cannot easily obtain.
- (4) Provide any available relevant data the **COUNTY** may have on file concerning the project.
- (5) Provide timely review and decisions in response to the **ARCHITECT'S** request for information and/or required submittals and deliverables, in order for the **ARCHITECT** to maintain the agreed-upon work schedule prepared in accordance with Attachment "C" of this Agreement.
- (6) Attend and participate in progress meetings as required and as coordinated and conducted by the **ARCHITECT**.
- (7) Assist the **ARCHITECT** the preparation of the project mailing list; provide representation, a site and stenographer for all public meetings; additionally:
 - Public Meetings*
 - (a) Approve agenda and all exhibits prior to public meeting.
 - (b) Approve date and location of the meeting.
 - (c) Review/approve Public Meeting Report.
- (8) Attend the Preliminary Concept Conference coordinated and conducted by the **ARCHITECT** and more particularly identified in Attachment "B" of the Agreement.
- (9) Assist the **ARCHITECT** as required in the coordination with the USACE and the Federal Emergency Management Agency (FEMA) and any other coordinating agency or entity.
- (10) Review and approve the Project design criteria.
- (11) Review and approve change orders as required and prepared by the **ARCHITECT**.

EXHIBIT B

-Scope of Services to be provided by the Architect



rike
ogden
figueroa
allex

July 22, 2020

Ms. Rocio Villarreal
Hidalgo County Purchasing Department
2802 S. Hwy 281
Edinburg, Texas 78539

RE: **Hidalgo County Annex IV Energy Management Bldg. B & C**
Professional Services Proposal

Dear Ms. Villarreal;

Thank you for the opportunity afforded to our firm to work on your proposed county renovation projects.

Following is our proposal to provide professional service for the above referenced projects. It is based on the two site visits attended by Mr. Jose Luis Rios, ROFA Architects; and Gabriel Hinojosa, Sigma Engineering. In addition, we understand the scope of work as illustrated in the project power point information provided to our firm.

Attached you will find a narrative of background information about the site and project as observed and photographically documented.

This fee proposal includes the following services for design and engineering services.

- Architectural
- Mechanical, electrical, and plumbing engineering

The following services, not yet determined to be required, may be under our contract but billed under additional or supplemental services.

- Structural Engineering
- Civil Engineering
- Landscape Design
- Specialty Consultant

Our proposed basic fee for the demolition and renovation of the above-mentioned project is 7.5% of the total construction cost.

We look forward to working with you and expediting the successful completion of your proposed projects.

Ms. Villarreal, please contact me should you have any questions.

Sincerely,
Rike Ogden Figueroa Allex Architects Inc.

A handwritten signature in black ink that reads "Luis A. Figueroa".

Luis A. Figueroa, AIA
Principal

Attachments

Annex IV, Emergency Management

Remodel/ Renovation of Buildings B and C

Purpose: This project is intended to provide renovations to two facilities which will serve as the Emergency Management Operations for which the County of Hidalgo officials will occupy during crisis management events. Hidalgo County in which Administration, County Judge, County Commissioners and other crisis management team members will work collaboratively to address the County's emergency needs

Scope of Work - Building B:

- ***Demolition:***
 - a. Remove floor tile
 - b. Relocate electrical conduits, data and communications cables and conceal
 - c. Remove restroom outer wall in order to expand
 - d. Remove old window unit in office
 - e. Relocate small server rack

- ***Renovations to include the following:***
 - a. Install new flooring (identify options available)
 - ✓ Exposed polished concrete
 - ✓ LVT Flooring
 - b. Ceilings: (options)
 - ✓ Exposed ceiling
 - ✓ Install j hooks to support network cables
 - ✓ Drop ceiling or drywall ceiling
 - c. Restroom A
 - ✓ Install new toilet (if applicable)
 - ✓ Install hand railing
 - ✓ Install new lavatory
 - ✓ Restroom facility must be in compliance with all applicable ADA standards
 - d. Install threshold and seal on garage door in order to water proof
 - e. Install new data and communications drops at new locations as shown on the floor plans

- f. Relocate server rack as shown on the plans
- g. Install new window unit in office
- h. Install new fire alarm or as required to comply with life safety codes
- i. Install new hand dryers
- j. Install LED Lamps
- k. Install new access control and/or security system
- l. Paint exterior walls
- m. Paint exterior railing
- n. All work performed shall be in compliance with state and local requirements
- o. Contractor shall be responsible for acquiring permits necessary for the successful completion of this project

Scope of Work - Building C:

- **Demolition:**

- a. Remove all existing VCT and carpeting
- b. Remove framing on designated areas as shown on plans
- c. Remove all (old) excess electrical and data and communications wiring
- d. Remove all existing ceiling tile and grid
- e. Remove all existing florescent lamps
- f. Remove and relocate electrical panels in large open common area
- g. Close door opening and relocate as indicated on plan
- h. Relocate electrical panel #2 and #3
- i. Remove plumbing and replace with new copper

- ***Renovations to include the following:***

- a. Install new flooring (options)
 - ✓ Exposed polished concrete
 - ✓ LVT flooring

b. Ceilings: (Options)

- ✓ Exposed ceiling
- ✓ Drop ceiling

d. Restroom A

- ✓ Install new toilet
- ✓ Install new lavatory w/ counter
- ✓ Install new shower
- ✓ Replace all plumbing rough-in
- ✓ Install two 24"X70"X18" lockers

e. Restroom B

- ✓ Install new toilet
- ✓ Install new lavatory w/ counter
- ✓ Replace all plumbing rough-in
- ✓ Install two 24"X70"X18" lockers

f. Install new doors

g. Install new data communications drops at each office and common areas

h. Install new janitorial floor sink

i. Install new mini-split for server room

j. Install new hand dryers

k. Install new drinking fountain (ADA compliance)

l. Install new data and communications rough in from Server to each office and common area

m. Set up exterior wall at common areas for 10 TV/Monitors

n. Install LED lap fixtures

o. Install new fire alarm

p. Install new security alarm

q. Install exhaust fans in restrooms

r. Install hot water heater, 40 gal capacity

s. Paint exterior walls on building

t. Paint railing

u. All work performed shall be in accordance and in compliance with ADA compliance.

v. Facility shall be sized accordingly to operate with backup generator power

w. All work performed shall be in compliant with local and state requirements

x. Contractor shall be responsible for acquiring permits required for the successful completion of this project.

Proposed project budget:

| | |
|---------------------------------|----------------------------|
| Building B – 868.8 gsft | <u>\$78,192.00</u> |
| Building C – 2623.6 gsft | <u>\$236,124.00</u> |
| <u>Total Budget</u> | <u>\$314,316.00</u> |

Budget is based on \$90.00/ sqft



Hidalgo Co.
Annex IV
Emergency Management
Bldg B & C

Bldg B – 868.8
Bldg C- 2,623.6

Building B Existing Condition

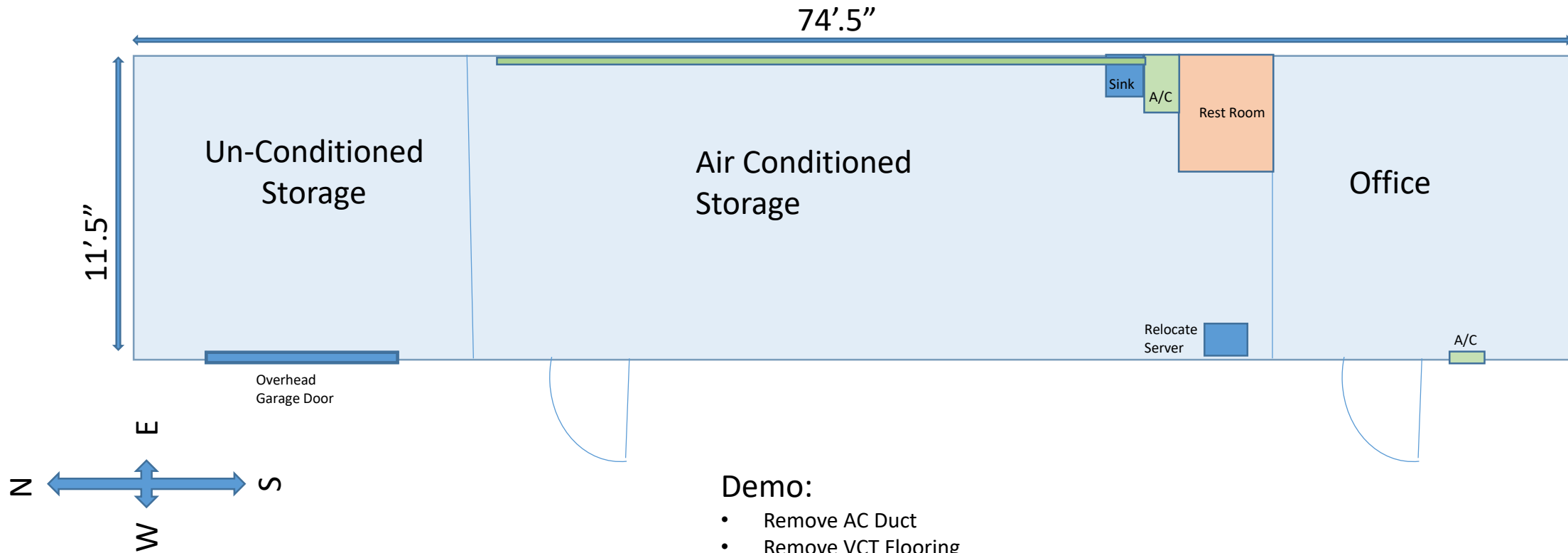

Demo:

- Remove AC Duct
- Remove VCT Flooring
- Relocate Computer Server Rack

Building B Reconditioned

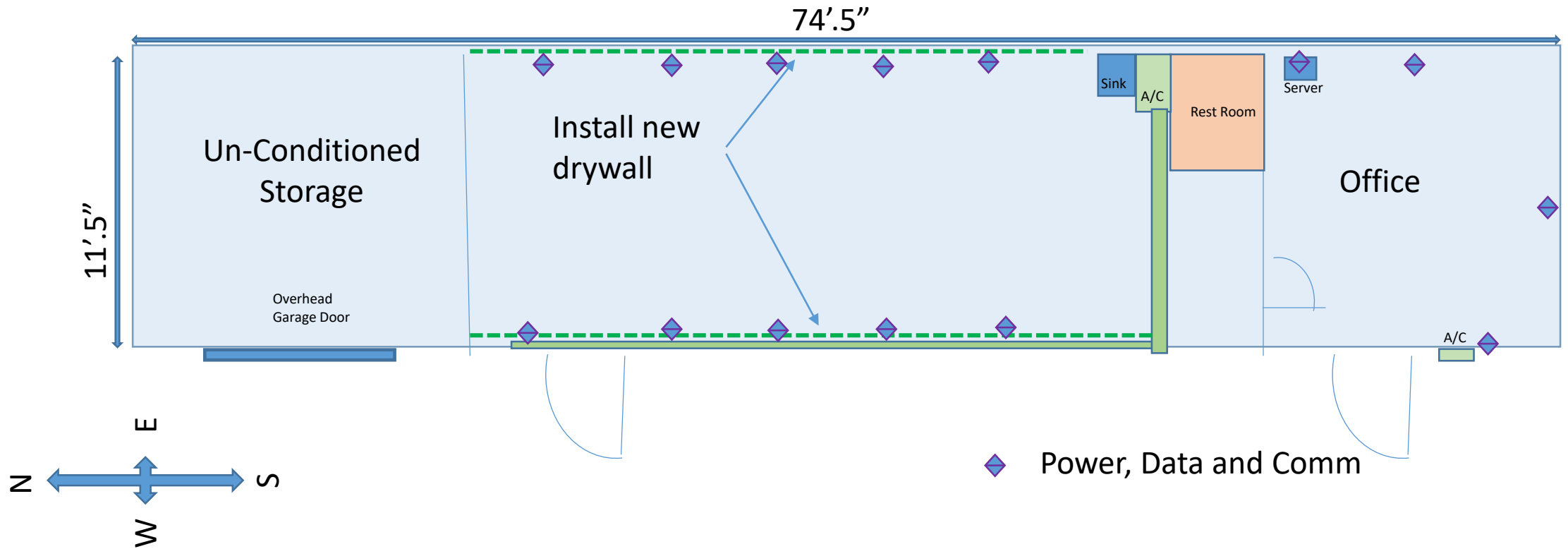

Bldg B- Renovation:

1. Install new flooring (options)

- a. Exposed polished concrete
- b. LVT flooring

2. Ceilings: (Options)

- a. Exposed ceiling
- b. Install “J” hooks to support network cables
- b. Drop ceiling

3. Restroom A

- a. Install new toilet
- b. Install new lavatory w/ counter

5. Install/replace new garage door

- 6. Install new data communications drops at each location to create work stations and at office
- 7. Install new mini-split in office
- 8. Install new fire alarm
- 9. Install new hand dryers in restroom
- 10. Install LED lap fixtures
- 11. Install new security alarm
- 12. Paint exterior walls on building
- 13. Paint railing
- 14. All work performed shall be in accordance and in compliance with ADA compliance.
- 15. All work performed shall be in compliant with local and state requirements
- 16. Contractor shall be responsible for acquiring permits required for the successful completion of this project.
- 17. Relocate server to office

Building C Existing Conditions

67'.1"

(3)

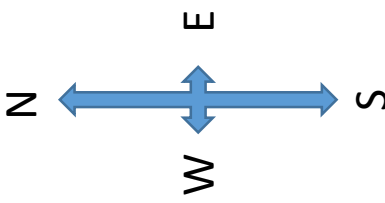
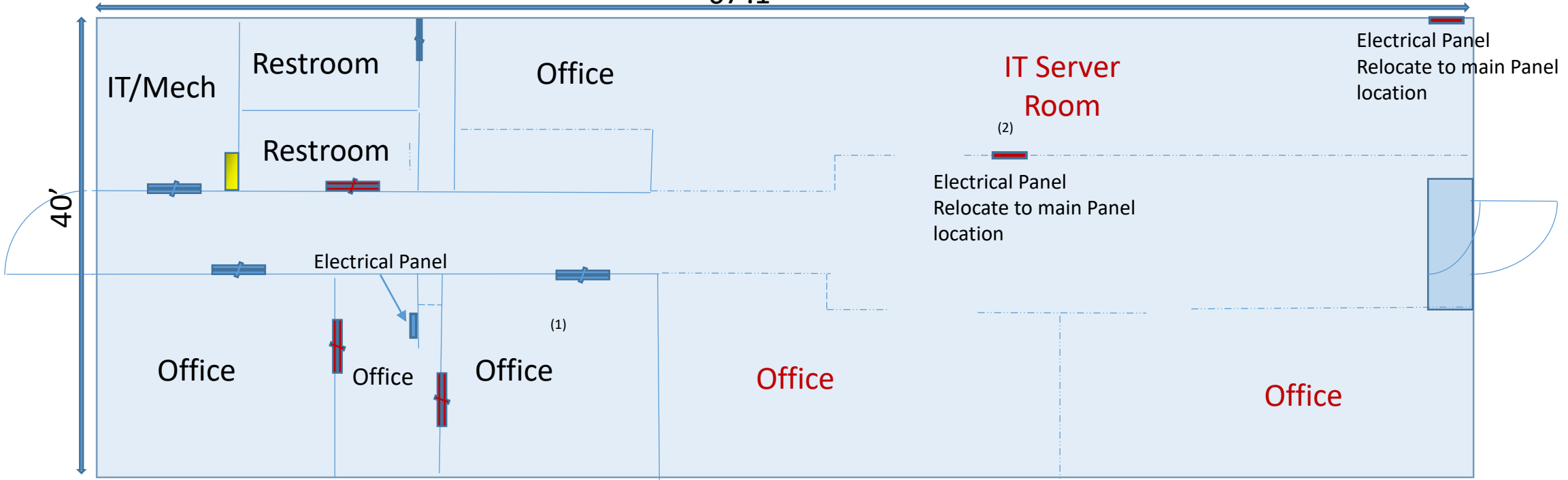

DEMO:

Countertop
To be removed



Close door openings







Demolition Bldg C

1. Remove all existing VCT and carpeting
2. Remove framing on designated areas as shown on plans
3. Remove all (old) excess electrical and data and communications wiring
4. Remove all existing ceiling tile and grid
5. Remove all existing florescent lamps
6. Remove and relocate electrical panels in large open common area
7. Close door opening and relocate as indicated on plan
8. Relocate electrical panel #2 and #3
9. Remove plumbing and replace with new copper

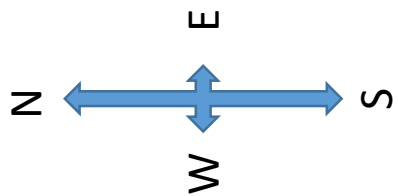
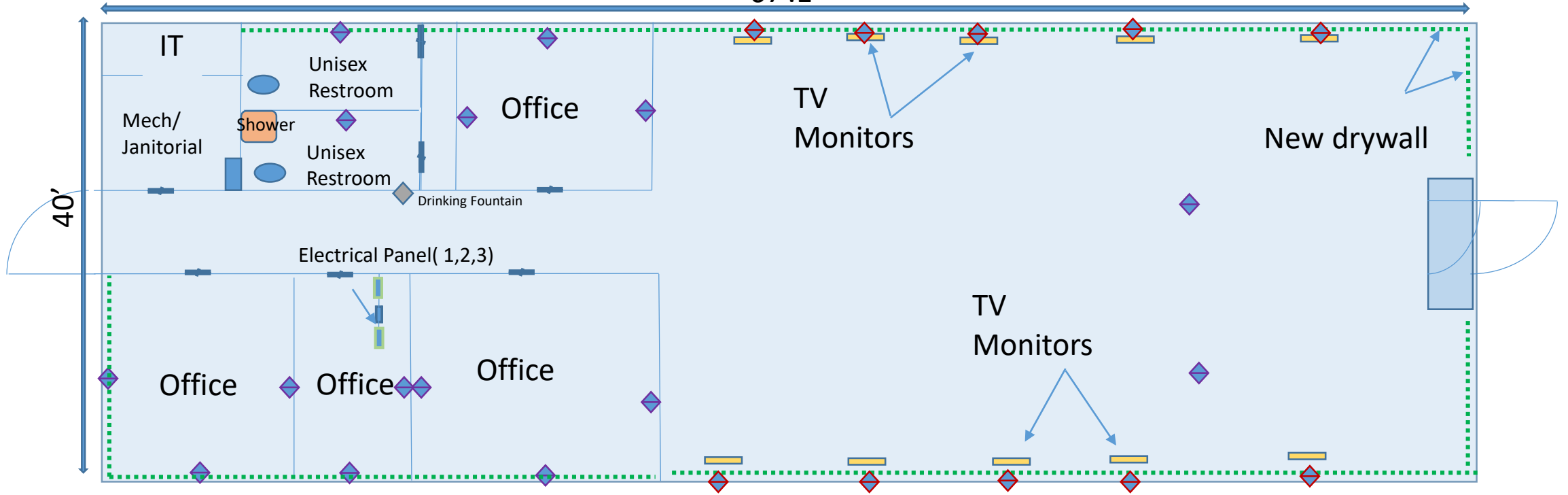
Building C Renovation

67'.1"



-  Power and TV Cable
-  Power, Data and Communications
-  Drinking Fountain

Bldg C - Renovation:

1. Install new flooring (options)

- a. Exposed polished concrete
- b. LVT flooring

2. Ceilings: (Options)

- a. Exposed ceiling
- b. Drop ceiling

3. Restroom A

- a. Install new toilet
- b. Install new lavatory w/ counter
- c. Install new shower
- d. Replace all plumbing rough-in
- e. Install two 24"X70"X18" lockers

4. Restroom B

- a. Install new toilet
- b. Install new lavatory w/ counter
- c. Replace all plumbing rough-in
- d. Install two 24"X70"X18" lockers

5. Install new doors

6. Install new data communications drops at each office and common areas

7. Install new janitorial floor sink

8. Install new mini-split for server room

9. Install new hand dryers

10. Install new drinking fountain (ADA compliance)

11. Install new data and communications rough in from Server to each office and common area

12. Set up exterior wall at common areas for 10 TV/Monitors

13. Install LED lap fixtures

14. Install new fire alarm

15. Install new security alarm

16. Install exhaust fans in restrooms

17. Install hot water heater, 40 gal capacity

18. Paint exterior walls on building

19. Paint railing

20. All work performed shall be in accordance and in compliance with ADA compliance.

21. Facility shall be sized accordingly to operate with backup generator power

22. All work performed shall be in compliant with local and state requirements

23. Contractor shall be responsible for acquiring permits required for the successful completion of this project.

EXHIBIT C

-Work Schedule

A detailed work schedule for the **Scope of Services provided by the Architect**, identified and more particularly described in Article 7 of this Agreement, shall be prepared by the **ARCHITECT** to be submitted and approved by the **COUNTY** in writing for each **Scope of Services provided by the Architect**. The work schedule will provide specific work sequence and definite review times by the **County** and the **Architect** of the work performed.

The **Architect** will diligently pursue the completion of the Scope of Services provided by the Architect as defined by the milestones and deliverable due dates outlined in the Scope of Services provided by the Architect associated work schedule.

The **Architect** will inform the **County** (in reasonable advance of the delay) should the **Architect** encounter delays that would prevent the performance of all work in accordance with the established work schedule.

EXHIBIT D
-Architect's Contract Rates

Hourly Rate Schedule:

1. **Principals:\$200.00/Hr.**
2. **Architects, Engineers and Project Managers:.....\$180.00/Hr.**
(other than principals)
3. **Project Management/Construction Administration\$150.00/Hr.**
4. **Interns and Designers:.....\$125.00/Hr.**
5. **CADD - Computer Aided Design and Drafting:\$100.00/Hr.**
6. **Clerical:\$50.00/Hr.**



EXHIBIT G

-Certificate of Insurance (*Hidalgo County*)