



EDUARDO "EDDIE" CANTU  
COUNTY COMMISSIONER



July 20, 2020

Texas Department of Transportation, Pharr District  
Attn: Arturo Lopez, Utility Coordinator  
PO Box 1717  
Pharr, TX 78577-1717

County: Hidalgo  
Federal Project No.: STP 1902(383)MM  
Highway: Dicker Road

U-15219  
ROW CSJ: 0921-02-370  
Const. CSJ: 0921-02-312  
From: Spur 115 (23<sup>rd</sup> St.)  
To: FM 2061 (Jackson Rd.)

RE: LoneStar Pipeline (Compensable Utility)

Dear Mr. Lopez,

This letter, together with the attached documents, is to request concurrence regarding the FINAL BILLING PACKAGE for compensable utilities related to the Dicker Road project in Hidalgo County, Texas.

LoneStar Pipeline has completed the adjustment and prepared the attached FINAL BILLING PACKAGE requesting payment in accordance with the LPA STANDARD UTILITY AGREEMENT dated February 26, 2019 included in the invoice (attached). As agreed upon, Hidalgo County Pct. No. 2 will not issue payment to a Utility Company until we receive concurrence from your office regarding the reimbursement of funds. Once the County receives concurrence from your office, then we will issue payment to the Utility Company and then request reimbursement from TxDOT.

As per guidance provided by TxDOT, the total combined authorized amount in the Advanced Funding Agreement can be utilized between actual ROW and Compensable Utility costs in any combination. As part of your concurrence please provide the County with the maximum amount available for reimbursement to the utility for this adjustment.

If you have any questions, please contact Mr. Eddie Rios with L&G Engineering at (956) 585-1909.

Sincerely,

Armando Garza, Jr.  
Hidalgo County Pct. #2 RPIC

cc: Honorable Eduardo "Eddie" Cantu – Hidalgo County Pct. 2, Commissioner  
Erika Zamora – Hidalgo County Pct. 2 Director of Administration  
Ricardo Gallaga, P.E. – L&G Engineering

# **REIMBURSEMENT REQUEST OF UTILITY**



c/o Kindle Energy LLC  
500 Alexander Park Drive, Suite 300  
Princeton, NJ 08540

March 23, 2020

Hidalgo County, Texas  
Attn: Hon. Richard Cortez, Hidalgo County Judge  
P.O. Box 758  
Edinburg, Texas 78540-0758

Dear Judge Cortez:

Pursuant to the LPA Standard Utility Agreement (SUA) entered into with Hidalgo County executed on February 26, 2019, Lonestar Pipeline Company, LLC (d/b/a Rio Grande Intrastate Pipeline, LLC) hereby submits its request for reimbursement of actual expenses incurred in relocation of the pipeline in support of the Dicker Road highway expansion project. Please note that while we are submitting expenses at this point, the project is not fully complete; we expect to incur some additional (minimal) expenses for the last step of removing casing, which cannot be completed until Hidalgo County completes its work at the intersection. Nevertheless, we expect the final installed cost to be less than the \$682,612 estimate that was attached to the SUA.

With respect to reimbursement, the check should be made to the following entity and sent as follows:  
Lonestar Pipeline Company, LLC  
c/o Kindle Energy LLC  
500 Alexander Park Drive, Suite 300  
Princeton, NJ 08540

In order to facilitate and expedite the reimbursement process, enclosed please also find the W-9 for Lonestar Pipeline Company, LLC.

Kindly reach out to Colin Harper, of CAMS Midstream at (713) 358-9787, or Ron Perego, Senior Project Director of M&H at (713) 516-3121 should you have further questions about the enclosed package of supporting materials and invoices.

Sincerely,

---

Lee McFalls  
Vice President  
Lonestar Pipeline Company, LLC

Encls.

c/o Kindle Energy LLC  
500 Alexander Park Drive, Suite 300  
Princeton, NJ 08540

Cc (via regular US mail, without full encls., only including cost summary):

Eduardo "Eddie" Cantu, Commissioner, Hidalgo County Precinct #2: [Eduardo.cantu@co.hidalgo.tx.us](mailto:Eduardo.cantu@co.hidalgo.tx.us)

Cc (via email only without full encls., only including cost summary):

Eddie Rios, L&G Engineering, Permitted/Compensable Utility Coordinator: [erios@lgeengineers.com](mailto:erios@lgeengineers.com)

Erika Zamora, Hidalgo County Pct #2: [Erika.zamora@co.hidalgo.tx.us](mailto:Erika.zamora@co.hidalgo.tx.us)

Colin Harper, Senior Vice President, CAMS Midstream: [charper@camstex.com](mailto:charper@camstex.com)

Ron Perego, M&H: [ron.perego@mhes.com](mailto:ron.perego@mhes.com)

T.J. Arredondo, Hidalgo County Planning Administrator: [tj.arredondo@hdhd.org](mailto:tj.arredondo@hdhd.org)

Armando Garza, Hidalgo County Pct #2 RPIC: [Armando.garzajr@co.hidalgo.tx.us](mailto:Armando.garzajr@co.hidalgo.tx.us)

Hazel Zepeda, TxDOT, Pharr District Utility Coordinator: [hazel.zepeda@txdot.gov](mailto:hazel.zepeda@txdot.gov)

Jacinto Garza, P.E., President L&G Engineering: [jacinto@lgeengineers.com](mailto:jacinto@lgeengineers.com)

Arnold Cortez, P.E., Project Manager- L&G Engineering: [acortez@lgeengineers.com](mailto:acortez@lgeengineers.com)

Elizabeth Quirk-Hendry, Lonestar Pipeline Company, LLC c/o Kindle Energy LLC:  
[beth.quirk.hendry@kindle-energy.com](mailto:beth.quirk.hendry@kindle-energy.com)

# **Form (1818) Buy America**

# Material Statement

Supplier: Apex Remington, Inc.
  
 Address: 13505 E. 61st St., Suite A
  
Broken Arrow, OK 74012
  
 Contract No.: PO# 17MH033-P08001 Rev. 0

County: Hidalgo
  
 Project: Lonestar Pipeline Dicker Road HDD Crossing
  
 Control: 0921-02-312
  
 Contractor: Strike, LLC

Purchase Order No.	Quantity (Amt./Units)	Material Description	Mill Name	Heat No.	Material Use	Required Spec.	Documentation	
							MTR	Cert.
17MH033- PO8001	650 FT	PIPE 8.625"x0.322" WT, SMLS/ERW, BE, API 5L-PSL2, GR X52, 14-16 MILS FBE, 20 MILS ARO	Borusan Mannesman Baytown	19029781 19029821 19029801	HDD Section	API 5L GR X52	Yes	
17MH033- PO8001	80 FT	PIPE 8.625"x0.250" WT, SMLS/ERW, BE, API 5L-PSL2, GR X52, 14-16 MILS FBE	Tex-Tube Houston	B508683	Pipeline Tie-ins	API 5L GR X52	Yes	
17MH033- PO8001	4	ELL, 45 DEG - 3R, 8", 0.250" WT, BW, MSS- SP-75, WPH-Y42	Custom Alloy Crp	SOHK	Pipeline Elbows	MSS-SP-75 WPH-Y42	Yes	

This is to certify that the materials listed above and on the attached supplement (if attached) are in conformance with the governing specification(s). This is to also certify that all manufacturing processes for steel and iron materials or for the application of coatings (epoxy, galvanizing, painting or any other coating that protects or enhances the value of the steel or iron metal) to these materials occurred in the United States of America. Manufacturing processes are defined as all processes required to change the raw ore or scrap metal into the finished in-place steel or iron product. The attached mill test reports (MTRs) and Certifications (Cert.) are offered as proof of Domestic Origin.

Subscribed and sworn to before me this 20 day of March, 2020

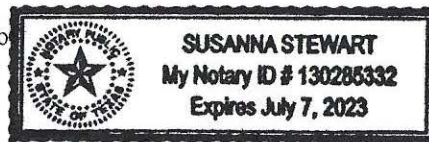

Notary Public S. Stewart

My Commission expires: July 7, 2023

I declare under penalty of perjury under the laws of the United States of America and the State of Texas that the foregoing is true and correct and that I am authorized to sign for the Firm listed below.

[Signature] Date 3-30-2020

Lisa Costello, Chief Operating Officer  
 (Type Name and Title)  
 M&H Energy Services  
 (Firm Name)

**ROW-U-48**

**“STATEMENT COVERING CONTRACT WORK”**



STATEMENT COVERING UTILITY CONSTRUCTION CONTRACT WORK
(AS APPEARING IN ESTIMATE)

Form ROW-U-48
(Rev. 9/18)
Page 1 of 1

U-Number: 15219

ROW CSJ Number: 0921-02-370 District: PHARR
County: HIDALGO Highway No.: Dicker Road
Federal Project No.:

I, Mark S. Gerding, a duly authorized and qualified representative of
Lonestar Pipeline Company, LLC, hereinafter referred to as Owner, am fully cognizant of the
facts and make the following statements in respect to work which will or may be done on a contract basis as it appears in the
estimate to which this statement is attached.

It is more economical and/or expedient for Owner to contract this adjustment, or Owner is not adequately staffed or equipped
to perform the necessary work on this project with its own forces to the extent as indicate on the estimate.

Procedure to be Used in Contracting Work

- A. Solicitation for bids is to be accomplished through open advertising and contract is to be awarded to the lowest
qualified bidder who submits a proposal in conformity with the requirements and specifications for the work to be
performed. Associated bid tabulations will be provided to the State.
B. Solicitation for bids is to be accomplished by circulating to a list of pre-qualified contractors or known qualified
contractors and such contract is to be awarded to the lowest qualified bidder who submits a proposal in conformity
with the requirements and specifications for the work to be performed. Associated bid tabulations will be provided to
the State. Such presently known contractors are listed below:
1. Driver Pipeline Company
2. Strike Construction LLC
3. Holloman Corporation
4. Troy Construction
5.
C. The work is to be performed under an existing continuing contract under which certain work is regularly performed
for Owner and under which the lowest available costs are developed. A copy of the existing contract will be provided
to the State. If only part of the contract work is to be done under an existing contract, give detailed information by
attachment hereto.
D. The utility proposes to contract outside the foregoing requirements and therefore evidence in support of its proposal
is attached to the estimate in order to obtain the concurrence of the State, and the Federal Highway Administration
Division Engineer where applicable, prior to taking action thereon (approval of the agreement shall be considered as
approval of such proposal).
E. The utility plans and specifications, with the consent of the State, will be included in the construction contract
awarded by the State. In the best interest of both the State and the Owner, the Owner requests the State to include
the plans and specifications for this work in the general contract for construction of Highway in
this area, so that the work can be coordinated with the other construction operations; and the construction
contract is to be awarded by the State to the lowest qualified bidder who submits a proposal in conformity with the
requirements and specifications for the work to be performed. If this option is chosen, attach form ROW-U-48-1, the
terms of which are incorporated herein by reference.

Handwritten signature in blue ink over the signature line.

Signature

Pipeline Director - Consultant
Title

01/17/19

Date

# **BID TABULATION**



### COMMERCIAL BID EVALUATION



<b>Client:</b> CAMS Midstream	<b>Rev.</b>	<b>Date</b>	<b>Issued For</b>	<b>By</b>	<b>Chk'd</b>	<b>App'd</b>	<b>Originated By:</b> M. Kleiner	<b>Date:</b> 8/5/19
	A	8/12/19	Information	MK	SS	RP		
<b>Project No.:</b> 17MH033							<b>Document No.:</b> 17MH033-8" Pipeline-CBE	
<b>Project:</b> Dicker Road-8" pipeline							<b>RFQ Package Name:</b> 8" Pipeline Install	

Bidder Information				
Company	Contact Name	Contact Number	Reference No. / Rev.	Status
Four Winds	Curtis Davis	817.233.2686		Bid Received
Strike Construction	Juan Salinas	832.734.8048		Bid Received
Holloman	Justin Schwausch			No bid
MPG	Aaron Simon			No bid
Driver	Frankie Williams			No bid
Pumpco	Derek Kieschnick			No bid

#### Recommendation

Upon review of the bids received by Strike and Four Winds for the 8" pipeline installation in Hidalgo County, TX, it is M&H's recommendation to move forward with Strike Construction, for a base total cost of \$322,754.

<b>Client:</b> CAMS Midstream		<b>COMMERCIAL BID EVALUATION - VENDOR BREAKDOWN</b> <b>8-INCH PIPELINE SEGMENT REPLACEMENT</b>		<b>Document No.:</b> 17MH033-8" Pipeline- CBE		
<b>Project No.:</b> 17MH033				<b>RFQ Package:</b> 8-Inch Pipeline Segment Replacement		
<b>Project Name:</b> Dicker Road HDD				<b>CBE Prepared By / Date:</b> M. Kleiner / 7.29.19		
<b>Vendor Information</b>			<b>Bidder 1</b>		<b>Bidder 2</b>	
Company Name:			Four Winds		Strike	
Contact:			Curtis Davis		Juan Salinas	
Contact No.:			817.233.2686		832.734.8048	
Contact Email:			<a href="mailto:cdavis.fourwinds@sbcglobal.net">cdavis.fourwinds@sbcglobal.net</a>		<a href="mailto:juan.salinas@strikeusa.com">juan.salinas@strikeusa.com</a>	
Reference No.:			N/A		N/A	
Item	Description	Qty.	Cost	Cost	Cost	
1	Price for mob/demob all equipment to complete HDD.		\$60,000.00		\$5,000.00	
2	Price for separate mob/demob with equipment required to complete removal of existing line pipe from North half of Dicker Road right of way.		\$115,000.00		\$5,000.00	
3	Price for separate mob/demob with equipment to complete removal of existing line pipe from North half of Dicker Road right of way.		\$115,000.00		\$5,000.00	
4	Price for pre-pull back hydrostatic testing of pipeline segment.		\$17,500.00		\$12,000.00	
5	Price for post-pull back 8-hour hydrostatic testing, cleaning, and drying of pipeline segment.		\$35,000.00		\$25,000.00	
6	Price to pre-test welders to operators API 1104 welding procedure, if required.		\$5,000.00		\$4,500.00	
7	Price for unloading, stringing, cribbing, welding, repairs of line pipe coating and field joint coating and jeeeping of pipe / fittings along right of way.		\$52,500.00		\$78,649.00	
8	Price for drilling, pull back, drying, and cleaning the 650'.		\$187,500.00		\$93,255.00	
9	Price for tie-ins at each end of the HDD.		\$35,000.00		\$15,000.00	
10	Each for installation of test stations / test leads as shown on alignment sheets.		\$500.00		\$0.00	
11	Price for removal of drilling fluid and coordinating with Water Hauler for the disposal of the drilling fluid.		\$10,000.00		\$15,000.00	
12	Price for installing tested tie-in spools, backfilling will be done in 6" lifts.		\$35,000.00		\$20,000.00	
13	Price for repairing damaged parking lot using subcontractor.		\$20,000.00		\$28,750.00	
14	Price for repairing damaged rock parking lot.		\$15,000.00		In Item 13	
15	Each for installation of pipeline marker signs.		\$500.00		\$500.00	
16	Price to repair or replace cast iron fence segments damaged during construction.		\$15,000.00		N/A	
17	Lump sum price each for cutting out of welds as selected by company's representative for testing, including re-beveling and re-welding pipe, which upon test proves satisfactory.		\$1,000.00		\$600.00	
18	Price to taper bore the proposed pipe to match the ID of the existing pipe.		\$1,000.00		\$1,500.00	
19	Price to provide manpower and equipment for Traffic Control Plan, use TxDOT drawing as go by.		\$10,000.00		\$3,000.00	
20	Price to provide A-Built drawings showing HDD path, spreadsheet for heat and weld maps.		\$3,000.00		\$10,000.00	
<b>TOTAL COST</b>			<b>\$733,500.00</b>		<b>\$322,754.00</b>	
<b>DELIVERY INFORMATION</b>						
Anticipated amount of time until "For Record" documents are provided:					As-Built and weld map drawings will be provided within 30 days of job completion.	
<b>GENERAL INFORMATION</b>						
Quote Validity:					30 Days	
Sub-Contractor Information:					Mo-Vac - Water, HDD Sub - N-Rock Solutions, Texan Dump Trucks - Parking Lot Repairs	
Payment Terms:					Net 30	
General Comments:						



**BID CLARIFICATIONS**  
**8-INCH PIPELINE SEGMENT REPLACEMENT**



<b>Project No. &amp; Name:</b>	<b>Rev.</b>	<b>Date</b>	<b>Issued For</b>	<b>By</b>	<b>Chk'd</b>	<b>App'd</b>	<b>Originated By:</b>	<b>Date:</b>
17MH033 - Dicker Rd. Pipeline Replacement							M. Kleiner	8/5/19
<b>Vendor Company Name:</b>							<b>Procurement Contact:</b>	
Strike							Michelle Kleiner - 281.664.6812	
<b>Vendor Contact:</b>							<b>Clarification Due Date:</b>	
Juan Salinas								

Item No.	Clarification	Response	Cost Impact
1	Schedule shows 1 day for blowdown for tie-in; note that the segment of pipe will be blown down 48 hours prior to Strike's mob, the blowdown will be done by others (CAMS Trident); Strike will be adding their locks for LOTO; please review cost.	No cost impact.	N/A
2	Bid Item #4 - Will the pullback segment be pulled back loaded with the test water?	No. Pretest water will be removed before pullback.	\$ -
3	Bid Item #6 - are the welders already qualified to the welding procedure provided?	No. Welders will be qualified for project.	\$ -
4	Bid Item #7 - how many cribs are included in the estimate? How many rollers?	6 bundles of skids anticipated and 20 pipe rollers	\$ -
5	Bid Item #8 - what material and equipment will Strike provide for water removal and line drying?	Foam swabs for drying to 1/4" penetration. 375 air compressor	\$ -
6	Bid Item #10 - Company will install replacement test stations, please adjust your estimate.	Please remove amount from price schedule.	\$ (5,000.00)
7	Bid Item #12 - how many bags of cement were included in your item #12 and at what cost per bag?	3 pallets of cement bags per tie-in location are estimated.	\$ -
8	Bid Item #13 - will Strike use a sub-contractor for the parking lot repairs? Who is that contractor?	Yes. Texan Dump Trucks	\$ -
9	Bid Item #16 - item 16 was shown as N/A, does Strike believe that the work can be completed without damage to the fence?	Correct, no fence repairs are anticipated.	\$ -
10	Where is the cost for hydrovac included, 2 days? Does this include cost for disposal of soil water removed during hydrovac?	Cost is included in Bid Item #8. Hydro-vac spoils will be hauled off-site.	\$ -
11	What is the estimated state and local taxes?	Labor will not be taxed. Materials will be taxed at 8.25%.	\$ -
12	Your Clarification & Qualifications indicate that "the estimate does not include any removal or disposal of ACM"; describe the method that Strike will handle any pipe found with ACM? ACM determination will be done on the day that Strike daylight the pipe, results are expected the following day. Is the plan to wrap the pipe for ACM? Is this effort included in the estimate?	Correct, Strike will shrink wrap existing pipe and stockpile for hauling by others.	\$ -
13	Identify the make and model of the HDD rig proposed for this project.	Vermeer D60	\$ -
14	You provided your complete list of equipment and rates. Please provide detailed job specific list of equipment slated for this project.	Please see clarifications for list of labor and equipment.	\$ -
15	Your total on bid sheet shows to be \$327,754 but we add it up to be \$312,751. Please confirm.	Please increase Bid item #7. Total Estimate is \$327,754.00	\$ 15,003.00
16	Please confirm all costs include per diems and expenses as applicable.	Confirmed	\$ -
17	If any subcontractors are planned to be used and have been listed on in previous clarifications, please list name of vendor and proposed associated work they will perform.	Mo-Vac- Water, HDD sub- N-Rock solutions	\$ -
18	Item #15 - is the \$500 a price for each, or inclusive of the two assumed signs (therefore \$250 each)?	Total \$500 for both signs	\$ -
19	Item #17 - Please confirm this price is per weld that would be cut.	Confirmed	\$ -
20	Item #18 - Please confirm this price is inclusive of both and not a price per taper bore.	Price is for both.	\$ -
21	Verify quote validity.	30 days	\$ -
22	Verify payment terms.	Net30	\$ -
23	Verify when "For Record" documents would be provided.	As builts and weld map dwgs will be provided within 30 days of job completion.	\$ -

## **Schedule (Start & End Dates)**

# (Utility Schedule of Work and Estimated Date of Completion)

Company Name: Lonestar Pipeline Company, LLC

U-Number: U15219

Start Date: 03/01/2019

Duration: 40 (Working days)

Estimated Completion Date: 05/31/2019

Initials:  Date: 01/17/19

## **(AS-BUILT) Drawings/Plans**



DICKER ROAD AT 10TH STREET  
HIDALGO COUNTY

DRAWING INDEX

EL7-9001	COVER SHEET/DRAWING INDEX
EL7-9101	LOCATION PLAN/GENERAL NOTES
EL7-9201	PIPELINE ROAD CROSSING
EL7-9401	PIPELINE TIE-IN SPOOL

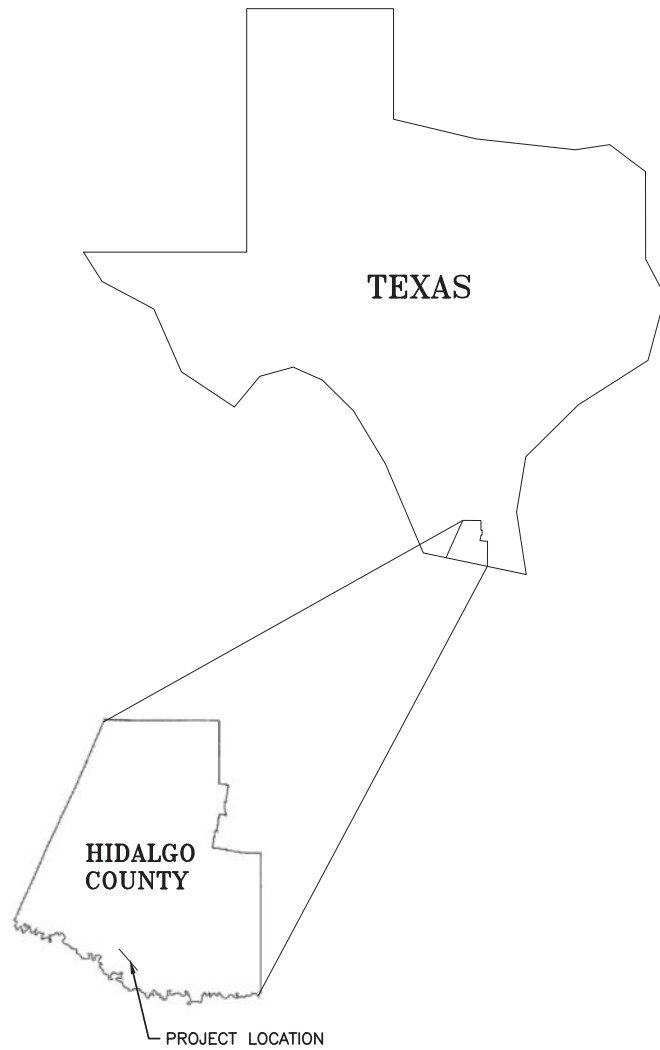

8" NATURAL GAS PIPELINE  
HORIZONTAL DIRECTIONAL DRILLED  
ROAD CROSSING

2019



File Path O:\CAMS\Dicker Rd\PIPELINE\_2D Details\17MH033\9000-9099 Pipeline Index\17MH033-EL7-9001.dwg Saved by: SMITHJ on: Jan. 14, 20 - 1:41 PM Plotted by: jason smith on: Jan. 28, 20 - 8:30 AM

NOTES

REFERENCE

NO.	DATE	DESCRIPTION	BY	CHK	APPD
0	01/28/20	ISSUED FOR USE	JS	GR	RP

TEXAS REGISTERED ENGINEERING FIRM F-4000  
WWW.MHES.COM

CONSOLIDATED ASSET MANAGEMENT SERVICES	
PIPELINE CROSSING DICKER ROAD HIDALGO COUNTY, TEXAS	
COVER SHEET DRAWING INDEX	
DRAWING NO.	EL7-9001
REVISION NO.	0

17MH033-EL7-9001

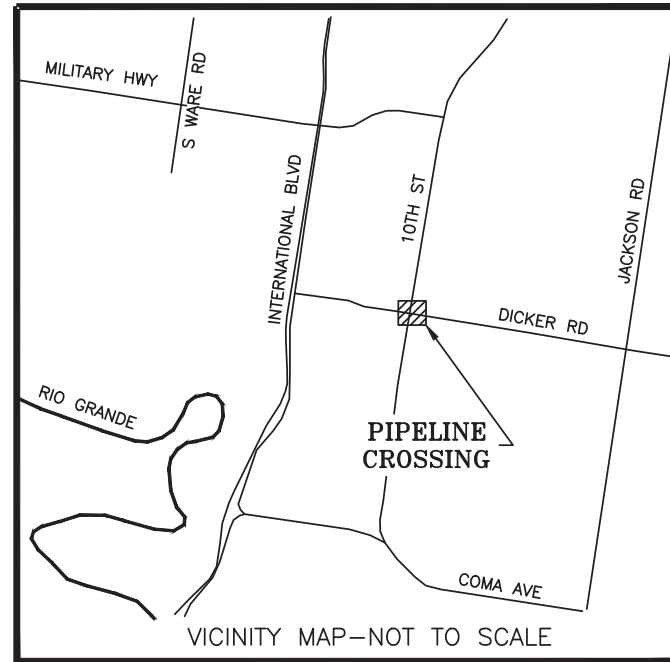

**NOTES:**

1. PIPELINES TO HAVE A MINIMUM COVER OF 36 INCHES.
2. POWER POLES LOCATED IN THE PROXIMITY OF THE TRENCH SHALL BE SECURED BY THE POWER COMPANY (POWER POLE OWNER) DURING EXCAVATION UNTIL TRENCH HAS BEEN BACKFILLED AND COMPACTED AND/OR THE POWER COMPANY DETERMINES IS SAFE TO UN-SECURE THE POLE. CONTRACTOR RESPONSIBLE TO COORDINATE AND SCHEDULE WORK WITH THE POWER COMPANY.
3. THE PLANS IDENTIFY AND PROVIDE LABELS FOR EXISTING UTILITIES (WATER, SANITARY SEWER, TELEPHONE CABLE, GAS, POWER, TV CABLE, AND/OR OTHER SPECIFICALLY LABELED UTILITY). LABELED UTILITIES WERE PLOTTED UTILIZING DIRECT FIELD INFORMATION AS SPOTTED BY UTILITY LOCATOR SERVICES. THE CONTRACTOR IS RESPONSIBLE TO REQUEST UTILITY SPOTTING AND CONTACT ALL UTILITY COMPANIES PRIOR TO COMMENCEMENT OF CONSTRUCTION ACTIVITIES. THE CONTRACTOR IS RESPONSIBLE FOR DETERMINING THE EXACT LOCATION AND ELEVATION OF EXISTING UTILITY LINES LOCATED WITHIN THE CONSTRUCTION AREA EITHER ADJACENT OR ACROSS FROM THE PROPOSED PIPELINE ALIGNMENT. THE CONTRACTOR SHALL BE RESPONSIBLE FOR ALL COSTS ASSOCIATED WITH REPAIRING UTILITIES DAMAGED BY THE CONTRACTOR'S EQUIPMENT OR PERSONNEL.
4. EXCAVATION PROTECTION SHALL BE PERFORMED IN ACCORDANCE WITH THE OCCUPATIONAL SAFETY AND HEALTH ADMINISTRATION (OSHA) STANDARDS AND INTERPRETATIONS, 29 CFR 1926, SUBPART P, "EXCAVATIONS." CONTRACTOR TO FURNISH ALL NECESSARY EQUIPMENT, TOOLS, MANPOWER, AND MATERIAL INCLUDING BUT NOT LIMITED TO SHEET PILES, METAL PLATES, TRENCH BOXES, AND/OR OTHER NECESSARY MATERIALS REQUIRED TO INSTALL BRACING TO SAFELY SECURE GROUND EXCAVATIONS WITH VERTICAL OR UNSTABLE EXCAVATION FACES. THIS ITEM IS APPLICABLE TO TRENCHES FIVE (5) FEET OR DEEPER.
5. STREETS SHALL REMAIN OPEN TO THRU TRAFFIC DURING CONSTRUCTION, AND HOLD DRIVEWAY INTERFERENCE TO A MINIMUM. BARRICADES, GUARDRAILS, AND WARNING SIGNS SHALL CONFORM TO THE LATEST EDITION OF THE TEXAS MANUAL ON UNIFORM TRAFFIC CONTROL DEVICES, AND GENERALLY BE LOCATED TO AFFORD MAXIMUM PROTECTION TO THE PUBLIC AS WELL AS CONSTRUCTION PERSONNEL AND EQUIPMENT, AND TO ASSURE AN EXPEDITIOUS TRAFFIC FLOW AT ALL TIMES DURING CONSTRUCTION. CONTRACTOR RESPONSIBLE FOR FURNISHING ALL NECESSARY BARRICADES, CHANNELIZING DEVICES, SIGNS, AND MANPOWER NEEDED FOR PROPER TRAFFIC CONTROL AND MANAGEMENT. TRAFFIC CONTROL WILL BE NEEDED WHEN WORKING NEAR OR ADJACENT TO EXISTING ROADS, INCLUDING BUT NOT LIMITED TO DICKER ROAD AND 10TH STREET.

**NOTES**

**REFERENCE**

NO.	DATE	DESCRIPTION	BY	CHK	APPD
0	01/28/20	ISSUED FOR USE	JS	GR	RP



CONSOLIDATED ASSET MANAGEMENT SERVICES

PIPELINE CROSSING  
DICKER ROAD  
HIDALGO COUNTY, TEXAS



LOCATION PLAN  
GENERAL NOTES

SCALE: AS SHOWN    PROJ. NO. 17MH033

DRAWING NO. EL7-9101

REVISION NO. 0

Saved by: SMTHU on: Jan. 28, 20 - 8:34 AM  
 Plotted by: jason.smith on: Jan. 28, 20 - 8:58 AM  
 File Path: O:\CAMS\Dicker Rd\Pipeline\2D Details\17MH033\9200-9899 Pipeline Drawings\17MH033-EL7-9201.dwg

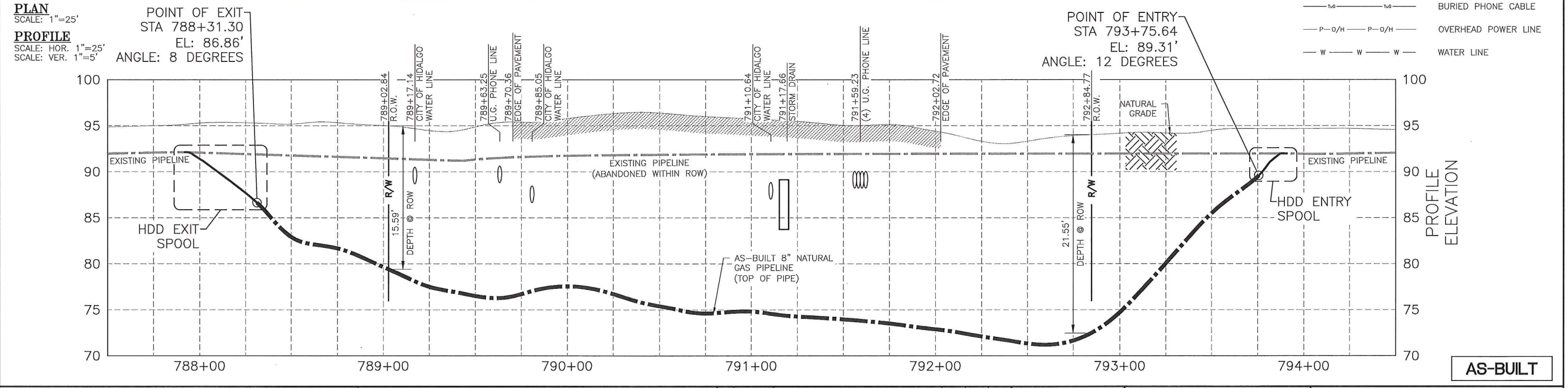
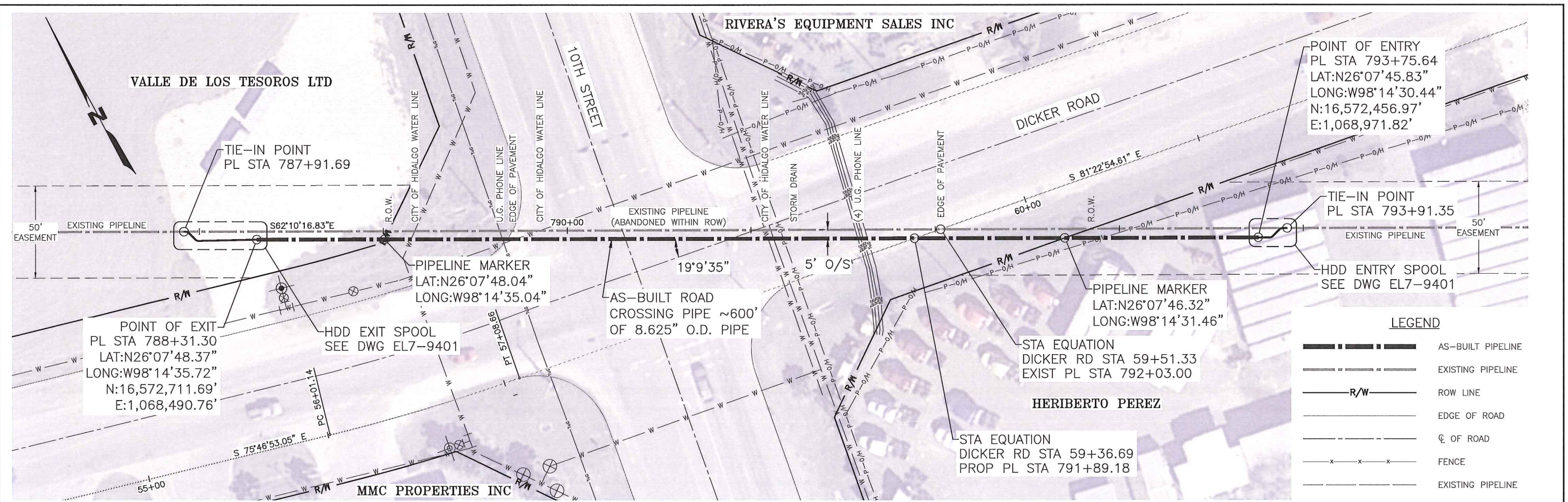

**LEGEND**

	AS-BUILT PIPELINE
	EXISTING PIPELINE
	ROW LINE
	EDGE OF ROAD
	☉ OF ROAD
	FENCE
	EXISTING PIPELINE
	BURIED PHONE CABLE
	OVERHEAD POWER LINE
	WATER LINE

**NOTES**

- REFER TO TXDOT "TEXAS MUTCD (MANUAL ON UNIFORM TRAFFIC CONTROL DEVICES), PART 6, TEMPORARY TRAFFIC CONTROL" FOR GUIDELINES ON TRAFFIC SAFETY PLAN.
- COORDINATES SHOWN ARE BASED IN HARN (HPGN DATUM) TEXAS STATE PLANES, SOUTH ZONE, US FOOT.

**REFERENCE**

NO.	DATE	DESCRIPTION	BY	CHK	APPD
2	01/28/20	AS-BUILT	JS	KM	RP
1	10/30/19	ADDED PL MARKERS AND CROSSING ANGLE	JS	GR	MG
0	07/19/19	ISSUED FOR USE	JS	GR	MG

CONSOLIDATED ASSET MANAGEMENT SERVICES

PIPELINE CROSSING  
DICKER ROAD  
HIDALGO COUNTY, TEXAS

PIPELINE  
ROAD CROSSING

SCALE: AS SHOWN

PROJ. NO. 17MH033

DRAWING NO. EL7-9201

REVISION NO. 2

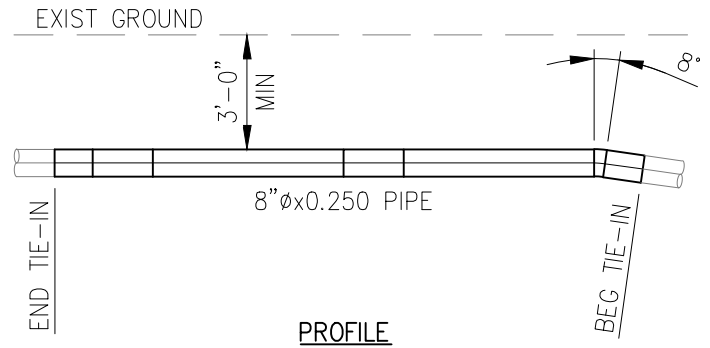
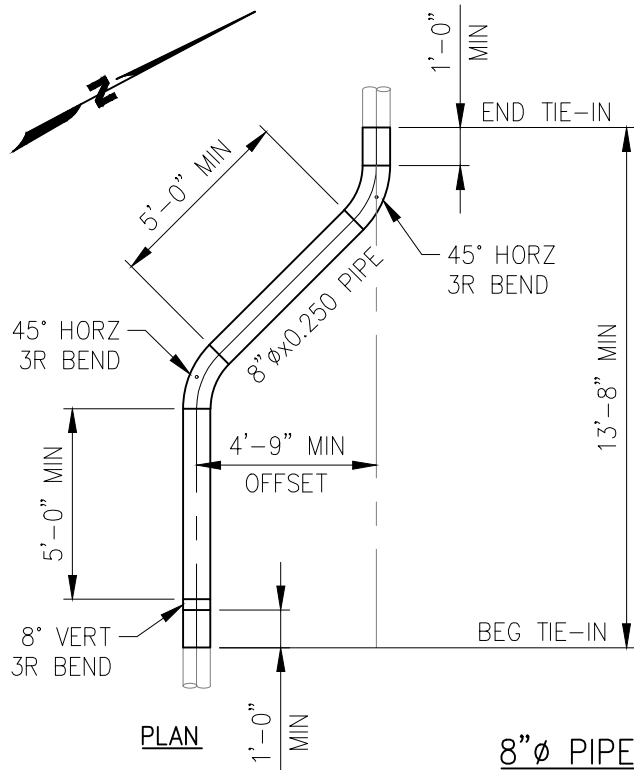

8"Ø PIPELINE HDD EXIT SPOOL

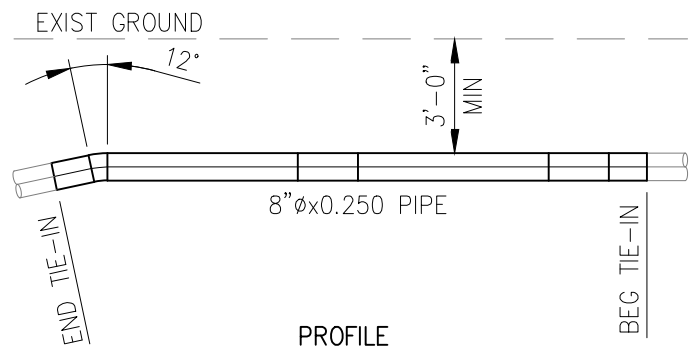
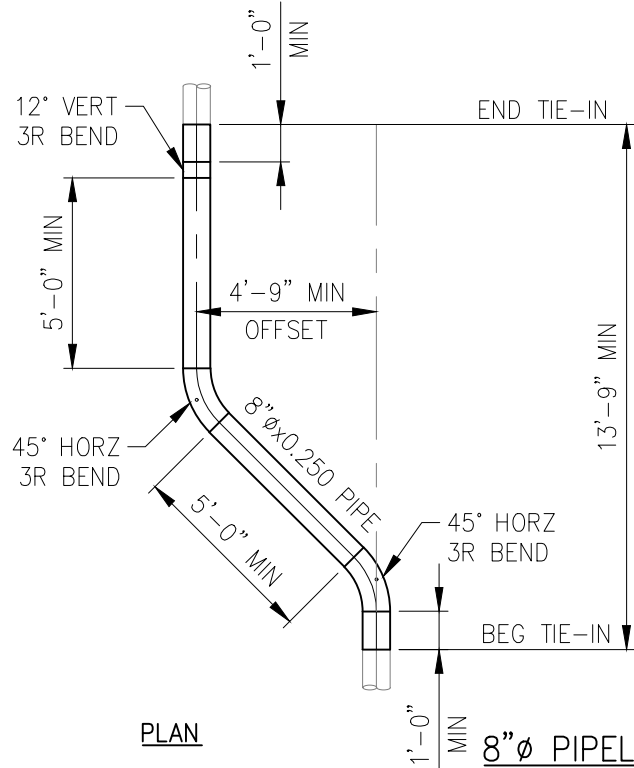

8"Ø PIPELINE HDD ENTRY SPOOL

Jan 28, 2020 - 8:36am O:\CAMS\Dicker Rd\PIPELINE\2D Details\17MH033\9200-9899 Pipeline Drawings\17MH033-EL7-9401.dwg

0	01/28/20	ISSUED FOR USE	JS	GR	MG
NO.	DATE	DESCRIPTION	BY	CHK	APPD
 <b>TEXAS REGISTERED ENGINEERING FIRM F-4000</b> <b>WWW.MHES.COM</b>					
SCALE: 1" = 5'		PROJ. NO. 17MH033			

**CAMS** CONSOLIDATED ASSET MANAGEMENT SERVICES  
Consolidated Asset Management Services

PIPELINE CROSSING  
 DICKER ROAD  
 HIDALGO COUNTY, TEXAS

PIPELINE  
 TIE-IN SPOOL

DRAWING NO. **EL7-9401** REVISION NO. **0**

17MH033-EL7-9401

# HEAT MAP & MTRS

# LONESTAR 8" PL ~ DICKER ROAD

104~190032~095

PO# 17MH033

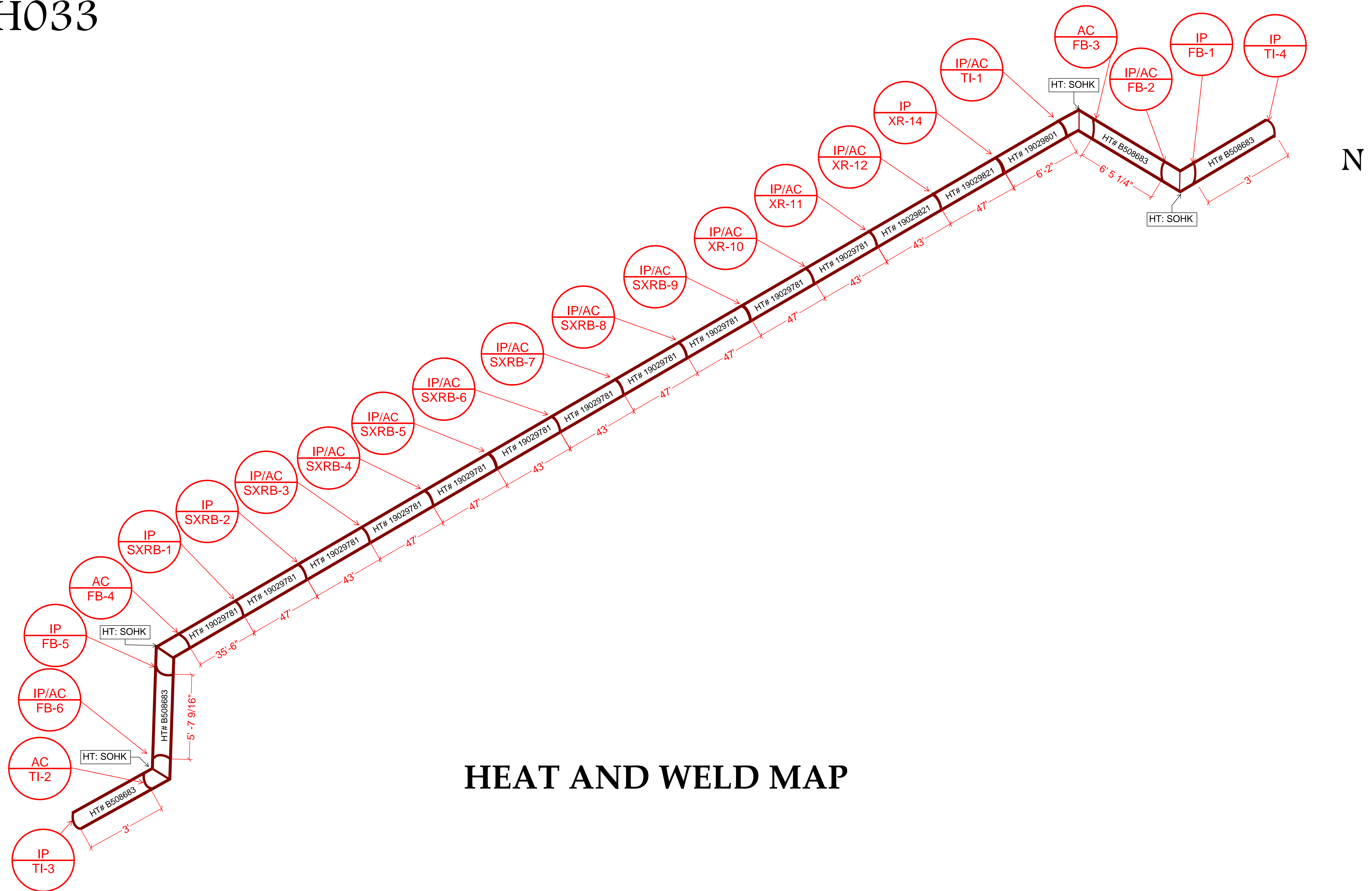

HEAT AND WELD MAP

S



### BORUSAN MANNESMANN MATERIAL TEST REPORT

HFW STEEL PIPE GENERAL INFORMATION																	
ITEM	O.D. (in)	Wall Thickness (in)	Length (ft)	Specification or Reference and Grade	Coating	End Finish	NDT Weld Seam	NDT Pipe Body	Drift	Visual and Dimension Control	Flattening Test	Min Collapse Pressure	Hydrostatic Test		Heat Treatment	Work Order	Date
1	8.625	0.322	38.0 - 47.0	API 5L 45th ed X52M PSL2	Zero VOC Clear Mill Coating	30° Beveled End	UT: OK N 10: 0.125in through hole	N/A	N/A	OK	OK	N/A	2970	5	Weld Seam Annealed Min 1588° F	W008407	7/7/2019

Chemical Analysis																		
ITEM	Heat No	Lot No	Chemical Analysis															
			Max	C (%)	Mn (%)	P (%)	S (%)	Si (%)	Al (%)	Cu (%)	Ni (%)	Cr (%)	Mo (%)	V (%)	Nb (%)	Ti (%)	B (%)	Ceq
			Min	C %	Mn % / 20	P %	S %	Si % / 30	Al %	Cu % / 20	Ni % / 80	Cr % / 20	Mo % / 16	V % / 10				0.250
1	19029761	N/A	Product	0.075	0.811	0.007	0.001	0.227	0.022	0.135	0.051	0.053	0.011	0.004	0.013	0.004	0.000	0.135
			Heat	0.071	0.832	0.007	0.000	0.200	0.013	0.123	0.054	0.062	0.001	0.000	0.010	0.003	0.000	0.129
			Product	0.076	0.872	0.007	0.001	0.214	0.020	0.143	0.058	0.068	0.015	0.004	0.014	0.003	0.000	0.140
1	19029781	N/A	Product	0.070	0.791	0.006	0.000	0.211	0.022	0.115	0.054	0.046	0.004	0.000	0.014	0.004	0.000	0.126
			Heat	0.050	0.840	0.008	0.002	0.220	0.030	0.140	0.060	0.050	0.019	0.003	0.020	0.001	0.000	0.121
			Product	0.071	0.818	0.006	0.001	0.227	0.023	0.139	0.050	0.051	0.016	0.004	0.014	0.003	0.000	0.131
1	19029801	N/A	Product	0.075	0.797	0.006	0.000	0.208	0.023	0.130	0.055	0.056	0.003	0.000	0.016	0.006	0.000	0.132
			Heat	0.060	0.890	0.008	0.002	0.210	0.026	0.140	0.060	0.060	0.019	0.004	0.018	0.001	0.000	0.124
			Product	0.073	0.832	0.007	0.001	0.228	0.023	0.135	0.051	0.052	0.015	0.004	0.014	0.003	0.000	0.134
1	19029821	N/A	Product	0.072	0.828	0.006	0.000	0.202	0.015	0.124	0.059	0.063	0.004	0.000	0.014	0.004	0.000	0.131
			Heat	0.060	0.840	0.007	0.002	0.240	0.032	0.130	0.050	0.040	0.018	0.003	0.021	0.002	0.000	0.121

Mechanical Properties																			
ITEM	Heat No	Lot No	Mechanical Properties																
			Transverse Weld						Transverse Body										
			Impact Test at 32° F (ft/lb)						Yield Strength (PSI)			Tensile Strength (PSI)			Elongation (%)			Rockwell Hardness (HRB)	
1	19029761	N/A	Product	70,770	85	154.62 / 100	150.86 / 100	156.83 / 100	154	100	71,710	74,600	33	85	148.13 / 100	147.91 / 100	158.89 / 100	152	100
1	19029781	N/A	Product	68,490	87	159.68 / 100	157.72 / 100	160.18 / 100	159	100	71,610	76,390	36	83	135.23 / 100	141.20 / 100	119.68 / 100	132	100
1	19029801	N/A	Product	68,910	86	173.85 / 100	166.34 / 100	164.45 / 100	168	100	73,970	77,420	34	85	160.07 / 100	139.95 / 100	126.91 / 100	142	100
1	19029821	N/A	Product	71,320	84	152.63 / 100	141.94 / 100	132.80 / 100	142	100	69,020	71,960	36	89	151.37 / 100	155.13 / 100	155.87 / 100	154	100

Coil Source: Steel Dynamics (1945 Airport Rd, Columbus, MS 39701)  
 Melted and Manufactured In USA

Steel Source: Steel Dynamics (1945 Airport Rd, Columbus, MS 39701)  
 Melted and Manufactured In USA

WE CERTIFY THE ABOVE MATERIAL HAS BEEN MANUFACTURED, PROCESSED, SAMPLED, TESTED, AND INSPECTED TO MEET THE REQUIREMENTS OF THE STANDARD IN REFERENCE. DETERMINATION OF MECHANICAL TESTING ARE ACCURATE AND TRACEABLE TO NIST AND CONFORM TO APPLICABLE TESTING METHODS. CONFORMS TO NACE MR-0175 FOR HARDNESS ONLY AS IT APPLIES TO API PRODUCTS. MAX HARDNESS DOES NOT EXCEED RC22. NOT VALID WITH INADEQUATE USE OF PIPE. THIS INSPECTION CERTIFICATE IS IN ACCORDANCE WITH API 5L 46TH EDITION.

Todd Reeves /   
 DIRECTOR OF QUALITY ASSURANCE

Purchase Order: 905-001011-00

Sales Order: S040504

Page: 4

Heat Number	Vendor Name	Description	Mfg Date: 12/01/15
b508683	SDI Columbus, MS, USA	API5L X52 8-5/8"X.250 WALL(22.38#)BARE,DRL,FEB	22.38 lb/ft

CHEMICAL ANALYSIS

	C	Mn	P	S	Ni	Cr	Cu	Mo	Si	Ti	V	Nb	B	Ca	CE
Ladle-	0.060	0.730	0.012	0.001	0.030	0.050	0.090	0.010	0.220	0.017	0.004	0.026	0.0001	0.0026	
Al:	0.017		SN:	0.005	N:										
Chem -	0.060	0.730	0.012	0.002	0.039	0.057	0.097	0.013	0.212	0.017	0.003	0.030	0.0003	0.0015	.11
Al:	0.019		SN:	0.005	N:										
Chem -	0.062	0.730	0.011	0.002	0.039	0.057	0.097	0.013	0.210	0.017	0.003	0.030	0.0004	0.0013	.12
Al:	0.018		SN:	0.005	N:										

ACCEPTANCE CRITERIA CEPCM=0.25

MECHANICAL PROPERTIES:

YS(ksi): 59.7 TS(ksi): 72.6 WTS(ksi): 77.6 EL(%): 35% HRB : 85 Y/T(%): 0.82

CHARPY TEST RESULTS body

Orientation:	Transverse	Specimen(s)	Energy(ft/lbs.)	L/E(mils)	% Shear
Spec. Size(in.):	.394" x .197" x 2.16	1	67	N/A	100
Test Temp.(oF):	0	2	69	N/A	100
Location:	3T90	3	71	N/A	100
Average:			70		

ACCEPTANCE CRITERIA Min. Ft/Lbs 10

COMMENTS

MINIMUM HYDROSTATIC TEST PRESSURE (psi): 2,270 FOR 5 seconds

MANUFACTURED TO THE 45TH EDITION OF API 5L SPECIFICATION

MELTED AND MANUFACTURED IN THE U.S.A.

HIGH FREQUENCY WELDED PRODUCT

WELD SEAM ANNEALING AT 1600 DEGREES F. MINIMUM

ULTRASONIC TESTED TO N-10 NOTCH 1/8 DRILLED HOLE

FLATTENING TEST PASSED

1.5 INCH T180 STRIP SPECIMEN

THIS MATERIAL MEETS : ASTM A53B, ASME SA53B LATEST EDITION

API 5L PSL 2 GRADE X52M

MEETS HARDNESS REQUIREMENTS OF NACE MRO 175/ISO 15156-2, CLAUSE A.2.1.1

MEETS ISO 10474 3.1.B/EN 10204:2004 3.1 / STANDARDS ARE LATEST REVISION

STEEL SUPPLIER:SDI-COLUMBUS,MS, U.S.A

COIL MANUFACTURER:SDI-COLUMBUS,MS,U.S.A

The above analyses and tensile properties are correct to the best of my knowledge and belief.

  
 -----  
 Quality Control Dept





LONESTAR  
HT#B508683

Hydrotested  
(1700)PSI

LONESTAR ARO  
HT#19029801  
HYDROTESTED  
(1700)PSI

LONESTAR  
HT#B508683  
HYDROTESTED  
(1700)PSI

GA 8 S20 WPHY42  
SOHK 221429-010

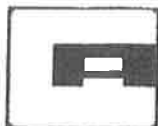

# Custom Alloy Corporation Manufacturer's Test Report

Heat Code: **SOHK**

**Customer:** APEX REMINGTON INC ( WOODLANDS, TX )

**Grade:** WPHY42

SMLS

**Specification:** MSS SP75 2014

**Material Type:** PIPE

**Quantity:** 4

**Item:** 08-3D45-HY42-SMLS-S20

**Lot:** 80257

**CHEMICAL ANALYSIS:** %

CE Product: 0.36

	<u>C</u>	<u>Mn</u>	<u>P</u>	<u>S</u>	<u>Si</u>	<u>Cr</u>	<u>Ni</u>	<u>Mo</u>	<u>Cb</u>	<u>Ta</u>	<u>Ti</u>	<u>N</u>
HEAT	0.20	0.96	0.008	0.003	0.25	0.05	0.05	0.02	0.001		0.001	
PRODUCT	0.17	0.98	0.006	0.006	0.27	0.04	0.06	0.01	0.010		0.010	
	<u>Cu</u>	<u>V</u>	<u>B</u>	<u>Co</u>	<u>Fe</u>	<u>Sn</u>	<u>Al</u>	<u>Mg</u>	<u>Ca</u>	<u>W</u>	<u>Zn</u>	<u>Zr</u>
HEAT	0.12	0.00	0.0002									
PRODUCT	0.12	0.01	0.0010									

**MECHANICAL PROPERTIES:**

	<u>Tensile, PSI</u>	<u>Yield, PSI</u>	<u>Elong% Inches</u>	<u>Orientation</u>	<u>Hardness</u>
BASE	75,061	49,135	32.6 2	TRANS	N/A

**HEAT TREATMENT:** NORMALIZED

**PO:** 022-001120-00

**Sales Order:** 221429-010

**Tag:** PO# 17MH033-PO8001, LINE 3

**NOTES:**

MAT. NORMALIZED @ 1650°F (+/-25°F)

**MELTED & MANUFACTURED IN THE USA**

Custom Alloy Corporation certifies that the finished fittings conform to the requirements of the above specifications.

10/18/2019

KEVIN FENLON, QA TECHNICAN

(908) 638-6200

# **REIMBURSABLE COST BREAKDOWN**



**REIMBURSABLE COST BREAKDOWN - DICKER RD HDD**



<b>Client:</b> CAMS Hidalgo County	<b>Issued For</b> Client Use	<b>Rev.</b> 0	<b>Date</b> 2/20/2020	<b>By</b> RP	<b>Originated by:</b> R. Perego	<b>Date:</b> 2/19/20
<b>Project No:</b> 17MH033	Client Use	1	3/23/2020	RP	<b>Document No:</b> 17MH033-PM2018	
<b>Project Name:</b> Dicker Road HDD					<b>Page:</b> 1 of 1	

Category / Company	Item	Qty	Hours	Rate	Cost	Total
<b>CAMS Operator Costs</b>						<b>\$338,887</b>
CAMS	Asset Management support		69.5	\$250	\$17,375	
M&H Energy Services	Engineering / Project Management		1341.25	\$175	\$234,915	
	Engineering / PM - Expenses				\$11,071	
Pipeline Inspection & Construction	Inspector - Onsite		227	\$80	\$18,160	
	Inspector - Expenses				\$5,751	
CAMS Trident	CP Test Stations - Materials				\$3,180	
	CP Test Stations - Labor	3	days	\$1,350	\$4,050	
	Pipe Laboratory Analysis				\$1,610	
	Inspection and Line Purge - Materials				\$1,006	
	Inspection and Line Purge - Labor	5	days	\$1,350	\$6,750	
Brighton Group	Surveying (subcontract)				\$4,980	
	Appraisal (subcontract)				\$5,000	
	Right of Way Agent Services		140	\$179	\$25,020	
UPS	Shipping				\$20	
<b>Temporary Easements</b>						<b>\$52,863</b>
Valle De Los Tesoros	Dicker Road NW Corner				\$40,000	
Heriberto Perez	Dicker Road SE Corner				\$12,863	
<b>Materials</b>						<b>\$34,102</b>
Apex Remington	8" x 0.322 X-52 Line Pipe w/ FBE + ARO	649.8	feet	\$29.36	\$19,078	
	8" x 0.250 X-52 Line Pipe w/ FBE	80	feet	\$19.73	\$1,578	
	Fittings - Ells + Caps	11	items	\$713.30	\$7,846	
	Freight estimate			\$3,000.00	\$3,000	
	Sales tax			\$2,598.98	\$2,599	
<b>General Contractor</b>						<b>\$177,409</b>
Strike Construction	Direct Labor & Equipment				\$103,011	
	Per Diem	6	days	\$145.00	\$870	
	Coastal Directional Drilling - HDD				\$40,946	
	Cemex - Flowable Fill				\$1,198	
	Texas Hwy Systems - Traffic Signs				\$1,005	
	Texan Dump Trucks - Hauling				\$15,328	
	Elite Oilfield - Portable Restroom				\$619	
	ALS - Welder Qualification Testing				\$1,746	
	United Rentals - Hydrovac Equipment				\$2,348	
	PSS - Pigs and Paint				\$624	
	Sentry - Onsite Traffic Control				\$281	
	JP Services - Hydrotesting				\$5,434	
	Vickrey & Associates - Surveying				\$3,997	
<b>Other Contractors</b>						<b>\$16,742</b>
Jackson, Sjoberg & Townsend	Legal Support				\$475	
MEG (Millennium Engineers Group)	Asbestos Testing				\$1,500	
Shawcor / Desert NDT	X-ray crew - Straight time		16	110.00	\$1,760	
	X-ray crew - Overtime		10	147.50	\$1,475	
	Film	24	each	9.50	\$228	
	Safety Equipment	6	each	\$20	\$120	
	Source Depletion Fee	3	each	\$40	\$120	
	Mileage	70	miles	\$1.35	\$95	
C4 Vacuum & Oilfield Service	Water Supply for Drilling / Hydrotest	220	bbls	\$0.50	\$110	
	Water Disposal		46.5	\$79	\$3,974	
OMNI Air & Nitrogen	Mobilization / Demobilization				\$1,950	
	Equipment		12	\$333	\$4,000	
	Per Diem	1	days	\$250	\$250	
	Fuel	208	gallons	\$3.30	\$686	
<b>TOTAL COST</b>						<b>\$620,003</b>

# W-9 FORM

## Request for Taxpayer Identification Number and Certification

**Give Form to the  
requester. Do not  
send to the IRS.**

▶ Go to [www.irs.gov/FormW9](http://www.irs.gov/FormW9) for instructions and the latest information.

Print or type. See Specific Instructions on page 3.	1 Name (as shown on your income tax return). Name is required on this line; do not leave this line blank. <b>Viva Alamo Holdings LLC</b>		
	2 Business name/disregarded entity name, if different from above <b>Lonestar Pipeline Company, LLC</b>		
	3 Check appropriate box for federal tax classification of the person whose name is entered on line 1. Check only <b>one</b> of the following seven boxes.  <input type="checkbox"/> Individual/sole proprietor or single-member LLC <input type="checkbox"/> C Corporation <input type="checkbox"/> S Corporation <input type="checkbox"/> Partnership <input type="checkbox"/> Trust/estate <input checked="" type="checkbox"/> Limited liability company. Enter the tax classification (C=C corporation, S=S corporation, P=Partnership) ▶ <b>P</b> <b>Note:</b> Check the appropriate box in the line above for the tax classification of the single-member owner. Do not check LLC if the LLC is classified as a single-member LLC that is disregarded from the owner unless the owner of the LLC is another LLC that is <b>not</b> disregarded from the owner for U.S. federal tax purposes. Otherwise, a single-member LLC that is disregarded from the owner should check the appropriate box for the tax classification of its owner. <input type="checkbox"/> Other (see instructions) ▶		
	4 Exemptions (codes apply only to certain entities, not individuals; see instructions on page 3):  Exempt payee code (if any) _____  Exemption from FATCA reporting code (if any) _____  <i>(Applies to accounts maintained outside the U.S.)</i>		
	5 Address (number, street, and apt. or suite no.) See instructions. <b>C/O Kindle Energy, LLC 500 Alexander Park Dr, Suite 300</b>		Requester's name and address (optional)
	6 City, state, and ZIP code <b>Princeton, NJ 08540</b>		
	7 List account number(s) here (optional)		

### Part I Taxpayer Identification Number (TIN)

Enter your TIN in the appropriate box. The TIN provided must match the name given on line 1 to avoid backup withholding. For individuals, this is generally your social security number (SSN). However, for a resident alien, sole proprietor, or disregarded entity, see the instructions for Part I, later. For other entities, it is your employer identification number (EIN). If you do not have a number, see *How to get a TIN*, later.

**Note:** If the account is in more than one name, see the instructions for line 1. Also see *What Name and Number To Give the Requester* for guidelines on whose number to enter.

<b>Social security number</b>									
<b>or</b>									
<b>Employer identification number</b>									
3	0	-	0	8	0	4	6	6	9

### Part II Certification

Under penalties of perjury, I certify that:

1. The number shown on this form is my correct taxpayer identification number (or I am waiting for a number to be issued to me); and
2. I am not subject to backup withholding because: (a) I am exempt from backup withholding, or (b) I have not been notified by the Internal Revenue Service (IRS) that I am subject to backup withholding as a result of a failure to report all interest or dividends, or (c) the IRS has notified me that I am no longer subject to backup withholding; and
3. I am a U.S. citizen or other U.S. person (defined below); and
4. The FATCA code(s) entered on this form (if any) indicating that I am exempt from FATCA reporting is correct.

**Certification instructions.** You must cross out item 2 above if you have been notified by the IRS that you are currently subject to backup withholding because you have failed to report all interest and dividends on your tax return. For real estate transactions, item 2 does not apply. For mortgage interest paid, acquisition or abandonment of secured property, cancellation of debt, contributions to an individual retirement arrangement (IRA), and generally, payments other than interest and dividends, you are not required to sign the certification, but you must provide your correct TIN. See the instructions for Part II, later.

<b>Sign Here</b>	Signature of U.S. person ▶	Date ▶ <b>3/22/2018</b>
------------------	----------------------------	-------------------------

## General Instructions

Section references are to the Internal Revenue Code unless otherwise noted.

**Future developments.** For the latest information about developments related to Form W-9 and its instructions, such as legislation enacted after they were published, go to [www.irs.gov/FormW9](http://www.irs.gov/FormW9).

### Purpose of Form

An individual or entity (Form W-9 requester) who is required to file an information return with the IRS must obtain your correct taxpayer identification number (TIN) which may be your social security number (SSN), individual taxpayer identification number (ITIN), adoption taxpayer identification number (ATIN), or employer identification number (EIN), to report on an information return the amount paid to you, or other amount reportable on an information return. Examples of information returns include, but are not limited to, the following.

- Form 1099-INT (interest earned or paid)

- Form 1099-DIV (dividends, including those from stocks or mutual funds)
- Form 1099-MISC (various types of income, prizes, awards, or gross proceeds)
- Form 1099-B (stock or mutual fund sales and certain other transactions by brokers)
- Form 1099-S (proceeds from real estate transactions)
- Form 1099-K (merchant card and third party network transactions)
- Form 1098 (home mortgage interest), 1098-E (student loan interest), 1098-T (tuition)
- Form 1099-C (canceled debt)
- Form 1099-A (acquisition or abandonment of secured property)

Use Form W-9 only if you are a U.S. person (including a resident alien), to provide your correct TIN.

*If you do not return Form W-9 to the requester with a TIN, you might be subject to backup withholding. See What is backup withholding, later.*

**REIMBURSABLE INVOICES**  
**“SUPPORTING DOCUMENTS”**



**CONSOLIDATED ASSET MANAGEMENT SERVICES, LLC**

919 Milam Street, Suite 2300 Houston, TX 77002-5418

TO: Lonestar Pipeline Company, LLC  
 c/o Frontera Energy Center  
 900 S Goodwin Road  
 Mission, TX 78572

Attention: Tom Callaghan  
[thomas.callaghan@lonestargen.com](mailto:thomas.callaghan@lonestargen.com)

Invoice No.: LONPIP 20170131  
 Date: 13-Feb-2017  
 Due Date: 28-Feb-2017  
 Prepared by: R.Wilson 713-358-9743

Pursuant to the terms of the Pipeline Services Agreement dated 11/1/2014 by and between Consolidated Asset Management Services, LLC ("CAMS") and Lonestar Pipeline Company, LLC (d/b/a Rio Grande Interstate Pipeline LLC) ("Lonestar"); Non-Routine fees per "Exhibit 1" to the above contract:

Non-Routine Services:

CAMS "Allocated Time for Colin Harper" related to SH 365 - Toll Road Project and Lonestar Pipeline Reactivation Plan for January (see attached time allocation schedule)

Pipeline Relocation Project in Hidalgo County - January	0.75	
Hours:	0.75	
Rate per Hour:	250.00	187.50

Other Non-Routine Services:

CAMS Trident - Locate & Mark Lines ( Inv# 53134 dated 1/31/17)	1,788.25
M&H Enterprises, Inc. - Dec Consultant Fees (Inv# INV055618 dated 1/10/17) plus 15% markup	3,408.51
M&H Enterprises, Inc. - Dec Consultant Fees (Inv# INV055619 dated 1/10/17) plus 15% markup	1,672.63
M&H Enterprises, Inc. - Dec Consultant Fees (Inv# INV055620 dated 1/10/17) plus 15% markup	3,799.19
M&H Enterprises, Inc. - Dec Consultant Fees (Inv# INV055621 dated 1/10/17) plus 15% markup	900.45
M&H Enterprises, Inc. - Dec Consultant Fees (Inv# INV055622 dated 1/10/17) plus 15% markup	450.23
M&H Enterprises, Inc. - Jan Consultant Fees (Inv# INV055762 dated 2/8/17) plus 15% markup	4,202.10
M&H Enterprises, Inc. - Jan Consultant Fees (Inv# INV055766 dated 2/8/17) plus 15% markup	6,803.40
M&H Enterprises, Inc. - Jan Consultant Fees (Inv# INV055767 dated 2/8/17) plus 15% markup	1,000.50
M&H Enterprises, Inc. - Jan Consultant Fees (Inv# INV056034 dated 2/8/17) plus 15% markup	<b>1,200.60</b>
Majic Valley Electric - January electric for rectifiers ( Inv# 290790-JAN dated 1/27/17)	30.05
Direct Energy - January electric ( Inv# 170380030035266 dated 2/07/17)	12.24
Direct Energy - January electric ( Inv# 170370030022514 dated 2/06/17)	26.43
Texas Excavation Safety System - January message fees ( Inv# 17-00426 dated 1/31/17)	57.00

TxDOT  
Reimbursable

TOTAL AMOUNT DUE: \$ 25,539.08

Wire Instructions:  
 Consolidated Asset Management  
 Services Texas, LLC  
 Amegy Bank  
 ABA#: 113011258  
 Account # 003771350

CO	Coding:					Amount
CAMSTEX	Acct		Subaccount			
LONPIP	1110000	104	000	00	0000	25,539.08
	3011000	104	354	00	0000	
	3050000	104	354	00	0000	(187.50)
	3055000	104	354	00	0000	(25,351.58)



M&H Enterprises Inc.  
 dba M&H Energy Services  
 19450 HWY 249, Suite 600  
 Houston, TX 77070  
 (281) 664-7222

# INVOICE

**Bill To: CAMS Midstream**

Colin Harper  
 919 Milam Street  
 Suite 2300  
 Houston, Texas 77002

Invoice Date: 2/8/2017  
 Invoice No: INV056034  
 Terms:

For services rendered for the calendar month ending **January 31, 2017**

**M&H Project No: 17MH033 Dicker Road Hidalgo County**

Inquiries can be sent to charper@camstex.com

**PROFESSIONAL SERVICES**

	Rate	Qty	Amount
Senior Project Manager	174.00	6.00	\$ 1,044.00
		6.00	\$ 1,044.00

3055000 104-354-00-00-000

Total Invoice Amount: \$ 1,044.00 ✓

*[Signature]*  
 RE: Conster  
Dicker Road Encroachment

Project Manager: M. Gerding

Task ID	Date	User ID	Employee Class	Billing Description	Pay Code	Qty	Bill Rate	Cost Amount	Bill Amount
---------	------	---------	----------------	---------------------	----------	-----	-----------	-------------	-------------

**M&H Project No: 17MH033 Dicker Road Hidalgo County**

**Professional Services**

<b>ENG-PC-3</b>	1/16/2017	gerdingm	Senior Project Manager		EXEMPT	3.00	174.00		522.00
	1/17/2017	gerdingm	Senior Project Manager	discussios with L & G	EXEMPT	2.00	174.00		348.00
	1/18/2017	gerdingm	Senior Project Manager		EXEMPT	1.00	174.00		174.00
			<b>Project Coordination - General</b>		<b>Task Totals</b>	<b>6.00</b>			<b>\$ 1,044.00</b>
			<b>Professional Services Total</b>			<b>6.00</b>			<b>\$ 1,044.00</b>

Total Invoice Amount: \$ 1,044.00



**CONSOLIDATED ASSET MANAGEMENT SERVICES, LLC**

919 Milam Street, Suite 2300 Houston, TX 77002-5418

TO: Lonestar Pipeline Company, LLC  
 c/o Frontera Energy Center  
 900 S Goodwin Road  
 Mission, TX 78572

Attention: Tom Callaghan  
[thomas.callaghan@lonestargen.com](mailto:thomas.callaghan@lonestargen.com)

Invoice No.: LONPIP 20170331  
 Date: 10-Apr-2017  
 Due Date: 25-Apr-2017  
 Prepared by: R. Wilson  
 713-358-9743

Pursuant to the terms of the Pipeline Services Agreement dated 11/1/2014 by and between Consolidated Asset Management Services, LLC ("CAMS") and Lonestar Pipeline Company, LLC (d/b/a Rio Grande Interstate Pipeline LLC) ("Lonestar"); Non-Routine fees per "Exhibit 1" to the above contract:

**Non-Routine Services:**

CAMS "Allocated Time for Colin Harper" related to Various Pipeline Discussions and Encroachments  
 (See attached time allocation schedule)

Various Pipeline Discussions - March	0.50	
Encroachments - March	1.00	
	Hours: 1.50	
	Rate per Hour: 250.00	375.00

**Other Non-Routine Services:**

CAMS Trident - Locate & Mark Lines ( Inv# 54019 dated 3/31/17)	492.36
M&H Enterprises, Inc. - Mar Consultant Fees (Inv# INV056446 dated 4/6/17) plus 15% markup	200.10
US DOT - 2015 User Fee Assessment ( Inv# 20178-030100 dated 3/17/17)	3,076.60
M&H Enterprises, Inc. - Mar Consultant Fees (Inv# INV056449 dated 4/6/17) plus 15% markup	TxDOT Reimbursable <b>400.20</b>
Majic Valley Electric - March electric for rectifiers ( Inv# 290790-MAR dated 3/27/17)	29.22
Direct Energy - March electric ( Inv# 170960030592047 dated 4/06/17)	14.77
Direct Energy - March electric ( Inv# 170950030579807 dated 4/05/17)	26.37
Texas Excavation Safety System - March message fees ( Inv# 17-03649 dated 3/31/17)	57.00

**TOTAL AMOUNT DUE: \$ 4,671.62**

**Wire Instructions:**  
 Consolidated Asset Management  
 Services Texas, LLC  
 Amegy Bank  
 ABA#: 113011258  
 Account # 003771350

CO	Coding:		Subaccount				Amount
CAMSTEX	Acct						
LONPIP	1110000	104	000	00	00	0000	4,671.62
	3011000	104	354	00	00	0000	
	3050000	104	354	00	00	0000	(375.00)
	3055000	104	354	00	00	0000	(4,296.62)

*Wilson*



M&H Enterprises Inc.  
 dba M&H Energy Services  
 19450 HWY 249, Suite 600  
 Houston, TX 77070  
 (281) 664-7222

# INVOICE

**Bill To: CAMS Midstream**

Colin Harper  
 919 Milam Street  
 Suite 2300  
 Houston, Texas 77002

Invoice Date: 4/6/2017  
 Invoice No: INV056449  
 Terms:

For services rendered for the calendar month ending **March 31, 2017**

**M&H Project No: 17MH033 Dicker Road Hidalgo County**

Inquiries can be sent to charper@camstex.com

**PROFESSIONAL SERVICES**

	Rate	Qty	Amount
Senior Technical Director	174.00	2.00	\$ 348.00
		2.00	\$ 348.00

Total Invoice Amount: \$ 348.00

OK to pay.  
 [Signature] 4/11/17  
 RE: LONESTAR PIPELINE  
 DICKER ROAD

Project Manager: M. Gerding

Task ID	Date	User ID	Employee Class	Billing Description	Pay Code	Qty	Bill Rate	Cost Amount	Bill Amount
---------	------	---------	----------------	---------------------	----------	-----	-----------	-------------	-------------

**M&H Project No: 17MH033 Dicker Road Hidalgo County**

**Professional Services**

ENG-PC-3	3/28/2017	gerdingm	Senior Technical Director	review proposal from lgengineers	EXEMPT	2.00	174.00		348.00
				<b>Project Coordination - General</b>	<b>Task Totals</b>	<b>2.00</b>			<b>\$ 348.00</b>
				<b>Professional Services Total</b>		<b>2.00</b>			<b>\$ 348.00</b>

Total Invoice Amount: \$ 348.00



**CONSOLIDATED ASSET MANAGEMENT SERVICES, LLC**

919 Milam Street, Suite 2300 Houston, TX 77002-5418

TO: Lonestar Pipeline Company, LLC  
 c/o Frontera Energy Center  
 900 S Goodwin Road  
 Mission, TX 78572

Attention: Tom Callaghan  
[thomas.callaghan@lonestargen.com](mailto:thomas.callaghan@lonestargen.com)

Invoice No.: LONPIP 20170430  
 Date: 9-May-2017  
 Due Date: 24-May-2017  
 Prepared by: R.Wilson  
 713-358-9743

Pursuant to the terms of the Pipeline Services Agreement dated 11/1/2014 by and between Consolidated Asset Management Services, LLC ("CAMS") and Lonestar Pipeline Company, LLC (d/b/a Rio Grande Interstate Pipeline LLC) ("Lonestar"); Non-Routine fees per "Exhibit 1" to the above contract:

Non-Routine Services:

CAMS "Allocated Time for Colin Harper" related to SH 365 - Toll Road Project and Lonestar Pipeline Reactivation Plan for April (see attached time allocation schedule)

Hours: 2.50  
 Rate per Hour: 250.00 625.00

Other Non-Routine Services:

CAMS Trident - Locate & Mark Lines ( Inv# 54488 dated 4/30/17)	700.87
M&H Enterprises, Inc. - April Consultant Fees (Inv# INV056676 dated 5/3/17) plus 15% markup	TxDOT Reimbursable 1,600.80
M&H Enterprises, Inc. - April Consultant Fees (Inv# INV056677 dated 5/3/17) plus 15% markup	1,600.80
Majic Valley Electric - April electric for rectifiers ( Inv# 290790-APR dated 4/27/17)	29.22
Direct Energy - April electric ( Inv# 171250030889968 dated 5/05/17)	12.38
Direct Energy - April electric ( Inv# 171240030875439 dated 5/04/17)	27.43
Texas Excavation Safety System - April message fees ( Inv# 17-05575 dated 4/30/17)	72.20

**TOTAL AMOUNT DUE: \$ 4,668.70**

**Wire Instructions:**  
 Consolidated Asset Management  
 Services Texas, LLC  
 Amegy Bank  
 ABA#: 113011258  
 Account # 003771350

CO	Coding:						Amount
CAMSTEX	Acct		Subaccount				
LONPIP	1110000	104	000 00 00 0000				4,668.70
	3011000	104	354 00 00 0000				
	3050000	104	354 00 00 0000				(625.00)
	3055000	104	354 00 00 0000				(4,043.70)

*R. Wilson*



M&H Enterprises Inc.  
 dba M&H Energy Services  
 19450 HWY 249, Suite 600  
 Houston, TX 77070  
 (281) 664-7222

# INVOICE

**Bill To: CAMS Midstream**

Colin Harper  
 919 Milam Street  
 Suite 2300  
 Houston, Texas 77002

Invoice Date: 5/3/2017  
 Invoice No: INV056676  
 Terms:

For services rendered for the calendar month ending **April 30, 2017**

**M&H Project No: 17MH033 Dicker Road Hidalgo County**

Inquiries can be sent to charper@camstex.com

**PROFESSIONAL SERVICES**

Senior Technical Director

	Rate	Qty	Amount
	174.00	8.00	\$ 1,392.00
		8.00	\$ 1,392.00

Total Invoice Amount: \$ 1,392.00 ✓

3055000 104-354-00-00-000

*[Signature]* 5.5.17  
 RE: *Loester Pipeline*  
*Dicker Road Project*

Project Manager: M. Gerding

Task ID	Date	User ID	Employee Class	Billing Description	Pay Code	Qty	Bill Rate	Cost Amount	Bill Amount
---------	------	---------	----------------	---------------------	----------	-----	-----------	-------------	-------------

**M&H Project No: 17MH033 Dicker Road Hidalgo County**

**Professional Services**

<b>ENG-COST</b>	4/18/2017	gerdingm	Senior Technical Director	cost estimate for road bore.	EXEMPT	4.00	174.00		696.00
				<b>Cost Estimate</b>	<b>Task Totals</b>	<b>4.00</b>			<b>\$ 696.00</b>
<b>ENG-PC-3</b>	4/4/2017	gerdingm	Senior Technical Director		EXEMPT	1.00	174.00		174.00
	4/6/2017	gerdingm	Senior Technical Director	tc with L&G	EXEMPT	3.00	174.00		522.00
				<b>Project Coordination - General</b>	<b>Task Totals</b>	<b>4.00</b>			<b>\$ 696.00</b>
<b>Professional Services Total</b>						<b>8.00</b>			<b>\$ 1,392.00</b>

Total Invoice Amount: \$ 1,392.00



**CONSOLIDATED ASSET MANAGEMENT SERVICES, LLC**

919 Milam Street, Suite 2300 Houston, TX 77002-5418

TO: Lonestar Pipeline Company, LLC  
 c/o Frontera Energy Center  
 900 S Goodwin Road  
 Mission, TX 78572

Attention: Tom Callaghan  
[thomas.callaghan@lonestargen.com](mailto:thomas.callaghan@lonestargen.com)

Invoice No.: LONPIP 20170630  
 Date: 12-Jul-2017  
 Due Date: 27-Jul-2017  
 Prepared by: R. Wilson  
 713-358-9743

Pursuant to the terms of the Pipeline Services Agreement dated 11/1/2014 by and between Consolidated Asset Management Services, LLC ("CAMS") and Lonestar Pipeline Company, LLC (d/b/a Rio Grande Interstate Pipeline LLC) ("Lonestar"); Non-Routine fees per "Exhibit 1" to the above contract:

**Non-Routine Services:**

CAMS "Allocated Time for Colin Harper" related to the Pipeline Reactivation Project and various encroachments  
*(see attached time allocation schedule)*

Various Encroachments - June	2.50		
Dicker Road Encroachment - June	1.00		
Pipeline Reactivation Project - June	4.00		
Los Cabos Subdivision Encroachment - June	0.50		
Santa Fe Trailer Encroachment - June	0.25		
	8.25		
Hours:	8.25		
Rate per Hour:	250.00	TxDOT Reimbursable	2,062.50

**Other Non-Routine Services:**

CAMS Trident - Locate & Mark Lines ( Inv# 55433 dated 6/30/17)	4,396.58	
WTKonsulting - Work for Reactivation Project (Inv# LSACT0001 dated 7/20/17)	2,025.00	
M&H Enterprises, Inc. - May Consultant Fees (Inv# INV056892 dated 6/12/17) plus 15% markup	800.40	
M&H Enterprises, Inc. - June Consultant Fees (Inv# INV057113 dated 7/12/17) plus 15% markup	5,002.50	
M&H Enterprises, Inc. - June Consultant Fees (Inv# INV057174 dated 7/12/17) plus 15% markup	7,168.53	TxDOT Reimbursable
M&H Enterprises, Inc. - June Consultant Fees (Inv# INV057175 dated 7/12/17) plus 15% markup	866.53	
Majic Valley Electric - June electric for rectifiers ( Inv# 290790-JUN dated 6/27/17)	29.22	
Direct Energy - June electric ( Inv# 171870031491888 dated 7/06/17)	12.61	
Direct Energy - June electric ( Inv# 171870031491889 dated 7/06/17)	26.37	
Texas Excavation Safety System - June message fees ( Inv# 17-08858 dated 6/30/17)	81.70	

TOTAL AMOUNT DUE: \$ 22,471.94

**Wire Instructions:**  
 Consolidated Asset Management  
 Services Texas, LLC  
 Amegy Bank  
 ABA#: 113011258  
 Account # 003771350

CO	Coding:					Amount
CAMSTEX	Acct		Subaccount			
LONPIP	1110000	104	000	00	0000	22,471.94
	3011000	104	354	00	0000	
	3050000	104	354	00	0000	(2,062.50)
	3055000	104	354	00	0000	(20,409.44)

*R. Wilson*

CAMS Time Allocation  
 Name: Colin Harper  
 Month: June 2017

Lonestar Pipeline O&M

**SH 365 - Toll Road Project**

No activity in June

SH 365 Project - Subtotal 0.00

**Various Encroachments**

1-Jun	Respond to Kindle and its counsel regarding any future county reimbursements for LaJoya Project	0.25
6-Jun	Several conversations with Mark Gerding and S&B Infrastructure regarding the Palmview Sewer Project	0.75
14-Jun	Calls with Kindle and attorney regarding status of various active encroachments	0.50
27-Jun	Provided historical insights on the Hidalgo County Drainage Line Strike Matter to Kindle	1.00

Various Encroachments - Subtotal 2.50

**Dicker Road Encroachment**

19-Jun	Reviewed Construction Agreement from Kindle counsel for Dicker Road	0.25
21-Jun	Conf Call with Mark Gerding at M&H regarding L&G Construction protocols for this project	0.25
28-Jun	Conf Call with Mark Gerding and e-mail to Kindle regarding TXDOT process and requirements	0.50

Dicker Road - Subtotal 1.00

**Pipeline Reactivation Project**

9-Jun	Conference call with Gener regarding reactivation status and his request to refresh the scope of work and cost estimates in advance of a Kindle meeting at the site in late June	0.50
12-Jun	E-mail and calls with Tommy Kilpatrick and Mark Gerding regarding Gener's request to refresh the scope and estimates for the pipeline reactivation; requested Tommy to update the compliance related matters and the ILI inspection scope and estimate and Mark to refresh the remaining scope	0.50
16-Jun	Updates from Mark and Tommy on status and e-mailed Gener with an update	0.50
19-Jun	Call with Tommy Kilpatrick regarding compliance related scope and estimate	0.25
21-Jun	Call with Mark Gerding at M&H regarding status of scope and estimate refresh for the pipeline reactivation update for Gener	0.50
21-Jun	Updated scope and estimate schedules and outline and sent initial draft of update to Gener	1.25
26-Jun	Refreshed and updated the scope and estimate and sent final to Gener in advance of his 6/27 mtg	0.50

Pipeline Reactivation - Subtotal 4.00

**Los Cabos Suddivision Encroachment**

15-Jun	Reviewed and commented on Construction Agreement draft for Kindle and counsel	0.50
--------	---	------

Los Cabos - Subtotal 0.50

**Santa Fe Trailer Encroachment**

5-Jun	Calls with Kindle and attorney regarding next steps and action to be taken	0.25
-------	--	------

Santa Fe Trailer - Subtotal 0.25

Total June 2017 Hours 8.25



M&H Enterprises Inc.  
 dba M&H Energy Services  
 19450 HWY 249, Suite 600  
 Houston, TX 77070  
 (281) 664-7222

# INVOICE

**Bill To: CAMS Midstream**

Colin Harper  
 919 Milam Street  
 Suite 2300  
 Houston, Texas 77002

Invoice Date: 7/12/2017  
 Invoice No: INV057174  
 Terms:

For services rendered for the calendar month ending **June 30, 2017**

**M&H Project No: 17MH033 Dicker Road Hidalgo County**

Inquiries can be sent to [charper@camstex.com](mailto:charper@camstex.com)

**PROFESSIONAL SERVICES**

	Rate	Qty	Amount
Designer 2	137.00	1.50	\$ 205.50
Designer 4	115.00	4.00	\$ 460.00
Senior Technical Director	174.00	32.00	\$ 5,568.00
		37.50	\$ 6,233.50

3055000 104-354-00-00-000

Total Invoice Amount: \$ 6,233.50

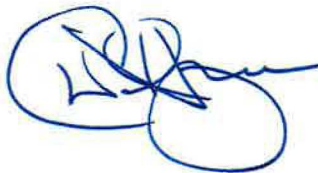
 7.13.17

Project Manager: M. Gerding

Task ID	Date	User ID	Employee Class	Billing Description	Pay Code	Qty	Bill Rate	Cost Amount	Bill Amount
---------	------	---------	----------------	---------------------	----------	-----	-----------	-------------	-------------

**M&H Project No: 17MH033 Dicker Road Hidalgo County**

**Professional Services**

<b>ENG-COST</b>	6/28/2017	coplenc	Designer 4	PL-RC-D Road Crossing Exhibits - AutoCAD Drawing	HOURLY	2.00 ✓	115.00 ✓		230.00
	6/29/2017	coplenc	Designer 4	PL-RC-D Road Crossing Exhibits - AutoCAD Drawing	HOURLY	2.00 ✓	115.00 ✓		230.00
				<b>Cost Estimate</b>	<b>Task Totals</b>	<b>4.00</b>			<b>\$ 460.00</b>
<b>ENG-PC-3</b>	6/6/2017	gerdingm	Senior Technical Director	Discussion with L&G Engineering (Joe Califfa & Bob Garcia) notice from L&G about approval, indicated that a follow up with a letter will come shortley. Discussion with Cloin Harper regarding approval, Colin had not been informed.	EXEMPT	1.00 ✓	174.00		174.00
	6/9/2017	gerdingm	Senior Technical Director	Discussions with L&G Engineering (Joe Califfa & Bob Garcia), TXDOT (Hazel Zepeda), CAMS (Colin Harper), L&G Engineering (Bob Garcia) Discussion regarding approval from TXDOT	EXEMPT	3.00 ✓	174.00		522.00
	6/23/2017	gerdingm	Senior Technical Director		EXEMPT	4.00 ✓	174.00		696.00
	6/26/2017	gerdingm	Senior Technical Director		EXEMPT	8.00 ✓	174.00		1,392.00
	6/27/2017	gerdingm	Senior Technical Director		EXEMPT	8.00 ✓	174.00		1,392.00
	6/28/2017	gerdingm	Senior Technical Director		EXEMPT	4.00 ✓	174.00		696.00
	6/29/2017	gerdingm	Senior Technical Director		EXEMPT	4.00 ✓	174.00		696.00
	6/1/2017	smithj	Designer 2	Convert client provided DGN files to DWG	HOURLY	1.00 ✓	137.00		137.00
	6/28/2017	smithj	Designer 2	Project Design Coordination	HOURLY	0.50 ✓	137.00		68.50
				<b>Project Coordination - General</b>	<b>Task Totals</b>	<b>33.50</b>			<b>\$ 5,773.50</b>
				<b>Professional Services Total</b>		<b>37.50</b>			<b>\$ 6,233.50</b>

Task ID	Date	User ID	Employee Class	Billing Description	Pay Code	Qty	Bill Rate	Cost Amount	Bill Amount
---------	------	---------	----------------	---------------------	----------	-----	-----------	-------------	-------------

Total Invoice Amount: \$ 6,233.50



**CONSOLIDATED ASSET MANAGEMENT SERVICES, LLC**

919 Milam Street, Suite 2300 Houston, TX 77002-5418

TO: Lonestar Pipeline Company, LLC  
 c/o Frontera Energy Center  
 900 S Goodwin Road  
 Mission, TX 78572

Attention: Tom Callaghan  
[thomas.callaghan@lonestargen.com](mailto:thomas.callaghan@lonestargen.com)

Invoice No.: LONPIP 20170731  
 Date: 14-Jul-2017  
 Due Date: 29-Jul-2017  
 Prepared by: R.Wilson 713-358-9743

Pursuant to the terms of the Pipeline Services Agreement dated 11/1/2014 by and between Consolidated Asset Management Services, LLC ("CAMS") and Lonestar Pipeline Company, LLC (d/b/a Rio Grande Interstate Pipeline LLC) ("Lonestar"); Non-Routine fees per "Exhibit 1" to the above contract:

**Non-Routine Services:**

CAMS "Allocated Time for Colin Harper" related to the Pipeline Reactivation Project and various encroachments  
 (see attached time allocation schedule)

Various Encroachments - July	0.75	
	Hours: 0.75	
	Rate per Hour: 250.00	187.50

**Other Non-Routine Services:**

CAMS Trident - Locate & Mark Lines ( Inv# 55793 dated 7/31/17)	717.75	
CAMS Trident - Groundbed Work for Aguilar & Anaya ( Inv# 55896 dated 7/31/17)	85,022.00	
M&H Enterprises, Inc. - February Engineering Services (Inv# INV056202 dated 3/8/17) plus 15% markup	6,020.25	
M&H Enterprises, Inc. - February Engineering Services (Inv# INV056211 dated 3/8/17) plus 15% markup	300.15	
M&H Enterprises, Inc. - February Engineering Services (Inv# INV056203 dated 3/8/17) plus 15% markup	3,001.50	
M&H Enterprises, Inc. - February Engineering Services (Inv# INV056213 dated 3/8/17) plus 15% markup	2,601.30	TxDOT Reimbursable
M&H Enterprises, Inc. - February Engineering Services (Inv# INV056212 dated 3/8/17) plus 15% markup	1,000.50	
M&H Enterprises, Inc. - February Engineering Services (Inv# INV056222 dated 3/8/17) plus 15% markup	1,470.28	
M&H Enterprises, Inc. - February Engineering Services (Inv# INV056210 dated 3/8/17) plus 15% markup	700.35	
M&H Enterprises, Inc. - July Engineering Services (Inv# INV057276 dated 8/9/17) plus 15% markup	7,354.83	TxDOT Reimbursable
M&H Enterprises, Inc. - July Engineering Services (Inv# INV057280 dated 8/9/17) plus 15% markup	769.93	
M&H Enterprises, Inc. - July Engineering Services (Inv# INV057281 dated 8/9/17) plus 15% markup	400.20	
Majic Valley Electric - July electric for rectifiers ( Inv# 290790-JUL dated 7/28/17)	29.22	
Direct Energy - July electric ( Inv# 172190031817930 dated 8/07/17)	12.38	
Direct Energy - July electric ( Inv# 172160031798704 dated 8/04/17)	28.21	
Texas Excavation Safety System - July message fees ( Inv# 17-10806 dated 7/31/17)	74.10	

TOTAL AMOUNT DUE: \$ 109,690.45

*R. Wilson*

**Wire Instructions:**  
 Consolidated Asset Management  
 Services Texas, LLC  
 Amegy Bank  
 ABA#: 113011258  
 Account # 003771350

CO	Acct	Coding:	Subaccount	Amount
LONPIP	1110000	104 000 00 0000		109,690.45
	3011000	104 354 00 0000		
	3050000	104 354 00 0000		(187.50)
	3055000	104 354 00 0000		(109,502.95)



M&H Enterprises Inc.  
 dba M&H Energy Services  
 19450 HWY 249, Suite 600  
 Houston, TX 77070  
 (281) 664-7222

# INVOICE

**Bill To: CAMS Midstream**

Colin Harper  
 919 Milam Street  
 Suite 2300  
 Houston, Texas 77002

Invoice Date: 3/8/2017  
 Invoice No: INV056213  
 Terms:

For services rendered for the calendar month ending **February 28, 2017**

**M&H Project No: 17MH033 Dicker Road Hidalgo County**

Inquiries can be sent to [charper@camstex.com](mailto:charper@camstex.com)

**PROFESSIONAL SERVICES**

	Rate	Qty	Amount
Senior Technical Director	174.00	13.00	\$ 2,262.00
		13.00	\$ 2,262.00

3055000 104-354-00-00-000

Total Invoice Amount: \$ 2,262.00 ✓

Project Manager: M. Gerding

Task ID	Date	User ID	Employee Class	Billing Description	Pay Code	Qty	Bill Rate	Cost Amount	Bill Amount
---------	------	---------	----------------	---------------------	----------	-----	-----------	-------------	-------------

**M&H Project No: 17MH033 Dicker Road Hidalgo County**

**Professional Services**

<b>ENG-PC-3</b>	2/6/2017	gerdingm	Senior Technical Director	Prepare project report	EXEMPT	2.00	174.00		348.00
	2/7/2017	gerdingm	Senior Technical Director	Prepare project report	EXEMPT	2.00	174.00		348.00
	2/8/2017	gerdingm	Senior Technical Director	Mtg at CAMS & travel	EXEMPT	1.00	174.00		174.00
	2/14/2017	gerdingm	Senior Technical Director	right of way	EXEMPT	2.00	174.00		348.00
	2/16/2017	gerdingm	Senior Technical Director		EXEMPT	2.00	174.00		348.00
	2/17/2017	gerdingm	Senior Technical Director	right of way easement for crossing	EXEMPT	3.00	174.00		522.00
				<b>Project Coordination - General</b>	<b>Task Totals</b>	<b>12.00</b>			<b>\$ 2,088.00</b>
<b>ENG-PC-4</b>	2/8/2017	gerdingm	Senior Technical Director	Mtg. at CAMS, project review	EXEMPT	1.00	174.00		174.00
				<b>Project Coordination - Site Visit</b>	<b>Task Totals</b>	<b>1.00</b>			<b>\$ 174.00</b>
				<b>Professional Services Total</b>		<b>13.00</b>			<b>\$ 2,262.00</b>

Total Invoice Amount: \$ 2,262.00



M&H Enterprises Inc.  
 dba M&H Energy Services  
 19450 HWY 249, Suite 600  
 Houston, TX 77070  
 (281) 664-7222

# INVOICE

**Bill To: CAMS Midstream**

Colin Harper  
 919 Milam Street  
 Suite 2300  
 Houston, Texas 77002

Invoice Date: **8/9/2017**  
 Invoice No: **INV057276**  
 Terms:

For services rendered for the calendar month ending **July 31, 2017**

**M&H Project No: 17MH033 Dicker Road Hidalgo County**

Inquiries can be sent to [charper@camstex.com](mailto:charper@camstex.com)

**PROFESSIONAL SERVICES**

	Rate	Qty	Amount
Designer 4	115.00	41.00	\$ 4,715.00
Project Controls Manager	115.00	0.50	\$ 57.50
Senior Technical Director	174.00	6.50	\$ 1,131.00
		48.00	\$ 5,903.50

**EXPENSES**

\$ 492.00

Total Invoice Amount: **\$ 6,395.50** ✓

3055000 104-354-00-00-000

*[Handwritten Signature]*  
 8.10.17  
 RE: Dicker Road

Project Manager: M. Gerding

Task ID	Date	User ID	Employee Class	Billing Description	Pay Code	Qty	Bill Rate	Cost Amount	Bill Amount
---------	------	---------	----------------	---------------------	----------	-----	-----------	-------------	-------------

**M&H Project No: 17MH033 Dicker Road Hidalgo County**

**Professional Services**

<b>ENG-COST</b>	7/17/2017	gerdingm ✓	Senior Technical Director	Cost estimate for options B & C; review and update of option A cost estimate	EXEMPT	5.00	174.00		870.00
				<b>Cost Estimate</b>	<b>Task Totals</b>	<b>5.00</b>			<b>\$ 870.00 ✓</b>
<b>ENG-PC-2</b>	7/17/2017	colliers	Project Controls Manager	change order, budget update	EXEMPT	0.50	115.00		57.50
				<b>Project Coordination - Controls</b>	<b>Task Totals</b>	<b>0.50</b>			<b>\$ 57.50 ✓</b>
<b>PL-RC</b>	7/17/2017	gerdingm	Senior Technical Director	update crossing drawings for options A, B & C	EXEMPT	1.00	174.00		174.00
	7/21/2017	gerdingm	Senior Technical Director	forward crossing drawings to Colin for review and comment	EXEMPT	0.50	174.00		87.00
				<b>Road Crossing Exhibits</b>	<b>Task Totals</b>	<b>1.50</b>			<b>\$ 261.00 ✓</b>
<b>PL-RC-D</b>	7/5/2017	coplenc	Designer 4		HOURLY	9.00	115.00		1,035.00
	7/6/2017	coplenc	Designer 4		HOURLY	4.00	115.00		460.00
	7/7/2017	coplenc	Designer 4	Prepared Crossing Exhibits	HOURLY	6.00	115.00		690.00
	7/10/2017	coplenc	Designer 4	Added storm drain to "Option A"	HOURLY	1.00	115.00		115.00
	7/11/2017	coplenc	Designer 4	Added storm drain to "Option B" and "Option C"	HOURLY	2.00	115.00		230.00
	7/17/2017	coplenc	Designer 4	Prepared various Road Crossing Option Exhibits	HOURLY	9.00	115.00		1,035.00
	7/18/2017	coplenc	Designer 4	Prepared various Road Crossing Option Exhibits	HOURLY	6.00	115.00		690.00
				<b>Road Crossing Exhibits - AutoCAD Drawing</b>	<b>Task Totals</b>	<b>37.00</b>			<b>\$ 4,255.00 ✓</b>
<b>PL-RC-M</b>	7/3/2017	coplenc	Designer 4	Prepared pipeline crossings	HOURLY	4.00	115.00		460.00
				<b>Road Crossing Exhibits - AutoCAD Modeling</b>	<b>Task Totals</b>	<b>4.00</b>			<b>\$ 460.00 ✓</b>
<b>Professional Services Total</b>						<b>48.00</b>			<b>\$ 5,903.50 ✓</b>

Task ID	Date	User ID	Employee Class	Billing Description	Pay Code	Qty	Bill Rate	Cost Amount	Bill Amount
---------	------	---------	----------------	---------------------	----------	-----	-----------	-------------	-------------

**Expenses**

<b>EXP - SOFTWARE</b>	7/8/2017	Software	Software Charges	Software charge - CAD	EXP	23.00	12.000	276.00	276.00
	7/15/2017	Software	Software Charges	Software charge - CAD	EXP	3.00	12.000	36.00	36.00
	7/22/2017	Software	Software Charges	Software charge - CAD	EXP	15.00	12.000	180.00	180.00
				<b>Software - 12 CAD / 25 SACS</b>	<b>Task Totals</b>	<b>41.00</b>		<b>492.00</b>	<b>\$ 492.00</b>
				<b>Expenses Total</b>		<b>41.00</b>			<b>\$ 492.00</b>

Total Invoice Amount: \$ 6,395.50



**CONSOLIDATED ASSET MANAGEMENT SERVICES, LLC**

919 Milam Street, Suite 2300 Houston, TX 77002-5418

TO: Lonestar Pipeline Company, LLC  
 c/o Frontera Energy Center  
 900 S Goodwin Road  
 Mission, TX 78572

Attention: Gener.Gotiangco  
[gener.gotiangco@kindle-energy.com](mailto:gener.gotiangco@kindle-energy.com)

Invoice No.: LONPIP 20170930  
 Date: 11-Oct-2017  
 Due Date: 26-Oct-2017  
 Prepared by: R.Wilson  
 713-358-9743

Pursuant to the terms of the Pipeline Services Agreement dated 11/1/2014 by and between Consolidated Asset Management Services, LLC ("CAMS") and Lonestar Pipeline Company, LLC (d/b/a Rio Grande Interstate Pipeline LLC) ("Lonestar"); Non-Routine fees per "Exhibit 1" to the above contract:

**Non-Routine Services:**

CAMS "Allocated Time for Colin Harper" related to the TRC Field Audit and various encroachments  
*(see attached time allocation schedule)*

Various Encroachments - September	1.25	
Texas Railroad Commission - Field Audit	4.50	
	5.75	
Hours:	5.75	
Rate per Hour:	250.00	1,437.50

**Other Non-Routine Services:**

CAMS Trident - Locate & Mark Lines ( Inv# 55959 dated 7/31/17)	857.73
CAMS Trident - Locate & Mark Lines ( Inv# 56844 dated 9/30/17)	4,497.14
M&H Enterprises, Inc. - September Engineering Services (Inv# INV057734 dated 10/9/17) plus 15% mark	900.45
M&H Enterprises, Inc. - September Engineering Services (Inv# INV057735 dated 10/9/17) plus 15% mark	400.20
Texas Excavation Safety System - Sep message fees ( Inv# 17-14127 dated 9/30/17)	91.20

TxDOT Reimbursable

**TOTAL AMOUNT DUE: \$ 8,184.22**

*R.Wilson*

**Wire Instructions:**  
 Consolidated Asset Management  
 Services Texas, LLC  
 Amegy Bank  
 ABA#: 113011258  
 Account # 003771350

CO	Coding:						Amount
CAMSTEX	Acct		Subaccount				
LONPIP	1110000	104	000	00	00	0000	8,184.22
	3011000	104	354	00	00	0000	
	3050000	104	354	00	00	0000	(1,437.50)
	3055000	104	354	00	00	0000	(6,746.72)



M&H Enterprises Inc.  
 dba M&H Energy Services  
 19450 HWY 249, Suite 600  
 Houston, TX 77070  
 (281) 664-7222

# INVOICE

**Bill To: CAMS Midstream**

Colin Harper  
 919 Milam Street  
 Suite 2300  
 Houston, Texas 77002

Invoice Date: 10/9/2017  
 Invoice No: INV057734  
 Terms:

For services rendered for the calendar month ending **September 30, 2017**

**M&H Project No: 17MH033 Dicker Road Hidalgo County**

Inquiries can be sent to charper@camstex.com

**PROFESSIONAL SERVICES**

Senior Technical Director

	Rate	Qty	Amount
	174.00	4.50	\$ 783.00
		4.50	\$ 783.00

Total Invoice Amount: \$ 783.00

*[Handwritten signature]* 10.11.17  
 RE: LONESTAR P/L  
 DICKER ROAD PROJ.  
 (REIMBURSABLE)

Project Manager: M. Gerding

Task ID	Date	User ID	Employee Class	Billing Description	Pay Code	Qty	Bill Rate	Cost Amount	Bill Amount
---------	------	---------	----------------	---------------------	----------	-----	-----------	-------------	-------------

**M&H Project No: 17MH033 Dicker Road Hidalgo County**

**Professional Services**

<b>ENG-PC-3</b>	9/13/2017	gerdingm	Senior Technical Director	discussion with L&G	EXEMPT	1.00	174.00		174.00
	9/14/2017	gerdingm	Senior Technical Director	L&G follow up; 90 exception & DUL	EXEMPT	2.00	174.00		348.00
	9/15/2017	gerdingm	Senior Technical Director	DUL	EXEMPT	1.50	174.00		261.00
				<b>Project Coordination - General</b>	<b>Task Totals</b>	<b>4.50</b>			<b>\$ 783.00</b>
				<b>Professional Services Total</b>		<b>4.50</b>			<b>\$ 783.00</b>

Total Invoice Amount: \$ 783.00



**CONSOLIDATED ASSET MANAGEMENT SERVICES, LLC**

919 Milam Street, Suite 2300 Houston, TX 77002-5418

TO: Lonestar Pipeline Company, LLC  
 c/o Frontera Energy Center  
 900 S Goodwin Road  
 Mission, TX 78572

Attention: Gener.Gotiangco  
[gener.gotiangco@kindle-energy.com](mailto:gener.gotiangco@kindle-energy.com)

Invoice No.: LONPIP 20180131  
 Date: 12-Feb-2018  
 Due Date: 27-Feb-2018  
 R.Wilson  
 Prepared by: 713-358-9743

Pursuant to the terms of the Pipeline Services Agreement dated 11/1/2014 by and between Consolidated Asset Management Services, LLC ("CAMS") and Lonestar Pipeline Company, LLC (d/b/a Rio Grande Interstate Pipeline LLC) ("Lonestar"); Non-Routine fees per "Exhibit 1" to the above contract:

**Non-Routine Services:**

CAMS "Allocated Time for Colin Harper" related to the TRCC Field Audit & various encroachments

(see attached time allocation schedule)

Limex Encroachment - January	0.25	
Campero Pharr Development Encroachment - January	2.75	
Texas Railroad Commission - Field Audit	2.75	
	<u>5.75</u>	
Hours:	5.75	
Rate per Hour:	250.00	1,437.50

**Other Non-Routine Services:**

CAMS Trident - Locate & Mark Lines ( Inv# 58593 dated 1/31/18)	1,497.59	
CAMS Trident - Replace Mission Pipeline Signs ( Inv# 58592 dated 1/31/18)	840.29	
Texas Railroad Commission - Letter of Credit Fees (Inv# BankDebit dated 1/19/18)	774.31	
M&H Enterprises, Inc. - December Engineering Services (Inv# INV058256 dated 1/11/18) plus 15% marku	200.10	TxDOT Reimbursable
M&H Enterprises, Inc. - January Engineering Services (Inv# INV058437 dated 2/8/18) plus 15% markup	3,101.55	
M&H Enterprises, Inc. - January Engineering Services (Inv# INV058439 dated 2/8/18) plus 15% markup	400.20	TxDOT Reimbursable
Majic Valley Electric - Dec electric for rectifiers ( Inv# 290790-JAN dated 1/26/18)	87.03	
Direct Energy -Dec electric ( Inv# 180370033681153 dated 2/06/18)	41.61	
Texas Excavation Safety System - Jan message fees ( Inv# 18-00432 dated 1/31/18)	49.40	

**TOTAL AMOUNT DUE: \$ 8,429.58**

**Wire Instructions:**  
 Consolidated Asset Management  
 Services Texas, LLC  
 Amegy Bank  
 ABA#: 113011258  
 Account # 003771350

CO	Coding:						Amount
CAMSTEX	Acct		Subaccount				
LONPIP	1110000	104	000	00	00	0000	8,429.58
	1140000	104	000	00	00	0000	0.00
	3050000	104	354	00	00	0000	(1,437.50)
	3055000	104	354	00	00	0000	(6,992.08)

*R.Wilson*



M&H Enterprises Inc.  
 dba M&H Energy Services  
 19450 HWY 249, Suite 600  
 Houston, TX 77070  
 (281) 664-7222

# INVOICE

**Bill To: CAMS Midstream**

Colin Harper  
 919 Milam Street  
 Suite 2300  
 Houston, Texas 77002

Invoice Date: 1/11/2018  
 Invoice No: INV058256  
 Terms:

For services rendered for the calendar month ending **December 31, 2017**

**M&H Project No: 17MH033 Dicker Road Hidalgo County**

Inquiries can be sent to charper@camstex.com

**PROFESSIONAL SERVICES**

	Rate	Qty	Amount
Senior Technical Director	174.00	1.00	\$ 174.00
		1.00	\$ 174.00

Total Invoice Amount: \$ 174.00 ✓

3055000 104-354-00-00-000

Project Manager: M. Gerding

*[Handwritten Signature]*  
 1.18.18  
 LONESTAR PIPELINE  
 RE: DICKEE ROAD  
 ENCROACHMENT

Task ID	Date	User ID	Employee Class	Billing Description	Pay Code	Qty	Bill Rate	Cost Amount	Bill Amount
---------	------	---------	----------------	---------------------	----------	-----	-----------	-------------	-------------

**M&H Project No: 17MH033 Dicker Road Hidalgo County**

**Professional Services**

<b>ENG-PC-3</b>	12/1/2017	gerdingm	Senior Technical Director	discussions with Anthony Garza with Hidalgo County	EXEMPT	1.00	174.00		174.00
				<b>Project Coordination - General</b>	<b>Task Totals</b>	<b>1.00</b>			<b>\$ 174.00</b>
				<b>Professional Services Total</b>		<b>1.00</b>			<b>\$ 174.00</b>

Total Invoice Amount: \$ 174.00



M&H Enterprises Inc.  
 dba M&H Energy Services  
 19450 HWY 249, Suite 600  
 Houston, TX 77070  
 (281) 664-7222

# INVOICE

**Bill To: CAMS Midstream**

Colin Harper  
 919 Milam Street  
 Suite 2300  
 Houston, Texas 77002

Invoice Date: 2/8/2018  
 Invoice No: INV058439  
 Terms:

For services rendered for the calendar month ending **January 31, 2018**

**M&H Project No: 17MH033 Dicker Road Hidalgo County**

Inquiries can be sent to charper@camstex.com

**PROFESSIONAL SERVICES**

	Rate	Qty	Amount
Senior Technical Director	174.00	2.00	\$ 348.00
		2.00	\$ 348.00

Total Invoice Amount: \$ 348.00

3055000 104-354-00-00-000

*[Handwritten Signature]* 2.09.18  
 RE: LOWESTAR PIPELINE  
 DICKER ROAD ENCROACHMENT

Project Manager: M. Gerding

Task ID	Date	User ID	Employee Class	Billing Description	Pay Code	Qty	Bill Rate	Cost Amount	Bill Amount
---------	------	---------	----------------	---------------------	----------	-----	-----------	-------------	-------------

**M&H Project No: 17MH033 Dicker Road Hidalgo County**

**Professional Services**

ENG-PC-3	1/29/2018	gerdingm	Senior Technical Director	DUL prep	EXEMPT	1.00	174.00		174.00
	1/30/2018	gerdingm	Senior Technical Director	DUL package	EXEMPT	1.00	174.00		174.00
<b>Project Coordination - General</b>					<b>Task Totals</b>	<b>2.00</b>			<b>\$ 348.00</b>
<b>Professional Services Total</b>						<b>2.00</b>			<b>\$ 348.00</b>

Total Invoice Amount: \$ 348.00



**CONSOLIDATED ASSET MANAGEMENT SERVICES, LLC**

919 Milam Street, Suite 2300 Houston, TX 77002-5418

TO: Lonestar Pipeline Company, LLC  
 c/o Frontera Energy Center  
 900 S Goodwin Road  
 Mission, TX 78572

Attention: Gener.Gotiangco  
[gener.gotiangco@kindle-energy.com](mailto:gener.gotiangco@kindle-energy.com)

Invoice No.: LONPIP 20180331  
 Date: 9-Apr-2018  
 Due Date: 24-Apr-2018  
 R.Wilson  
 Prepared by: 713-358-9743

Pursuant to the terms of the Pipeline Services Agreement dated 11/1/2014 by and between Consolidated Asset Management Services, LLC ("CAMS") and Lonestar Pipeline Company, LLC (d/b/a Rio Grande Interstate Pipeline LLC) ("Lonestar"); Non-Routine fees per "Exhibit 1" to the above contract:

**Non-Routine Services:**

CAMS "Allocated Time for Colin Harper" related to the TRCC Field Audit

(see attached time allocation schedule)

Texas Railroad Commission - Field Audit

	1.75	
Hours:	1.75	
Rate per Hour:	250.00	437.50

**Other Non-Routine Services:**

CAMS Trident - Locate & Mark Lines ( Inv# 59590 dated 3/29/18)	4,129.74
US DOT - 2018 User Fee Assessment ( Inv# 20188-030257 dated 3/12/18)	3,057.40
M&H Enterprises, Inc. - October Engineering Services (Inv# INV057940 dated 11/8/17) plus 15% markup	TxDOT Reimbursable 1,900.95
M&H Enterprises, Inc. - February Engineering Services (Inv# INV058730 dated 3/12/18) plus 15% markup	200.10
M&H Enterprises, Inc. - February Engineering Services (Inv# INV058731 dated 3/12/18) plus 15% markup	TxDOT Reimbursable 1,200.60
Majic Valley Electric - Mar electric for rectifiers ( Inv# 290790-MAR dated 3/27/18)	72.72
Texas Excavation Safety System - Feb message fees ( Inv# 18-02011 dated 2/28/18)	46.55
USPS Trans#: 431212632 dated 3/29/18	3.35

**TOTAL AMOUNT DUE:**

**\$ 11,048.91**

**Wire Instructions:**  
 Consolidated Asset Management  
 Services Texas, LLC  
 Amegy Bank  
 ABA#: 113011258  
 Account # 003771350

CO	Coding:		Subaccount				Amount
CAMSTEX	Acct						
LONPIP	1110000	104	000	00	00	0000	11,048.91
	1140000	104	000	00	00	0000	0.00
	3050000	104	354	00	00	0000	(437.50)
	3055000	104	354	00	00	0000	(10,611.41)

*R.Wilson*

344973

**INVOICE**



M&H Enterprises Inc.  
dba M&H Energy Services  
19450 HWY 249, Suite 600  
Houston, TX 77070  
(281) 664-7222

Invoice Date: 11/8/2017  
Invoice No: INV057940  
Terms:

**Bill To: CAMS Midstream**

Colin Harper  
919 Milam Street  
Suite 2300  
Houston, Texas 77002

For services rendered for the calendar month ending **October 31, 2017**

**M&H Project No: 17MH033 Dicker Road Hidalgo County**  
Inquiries can be sent to charper@camstex.com

**PROFESSIONAL SERVICES**

	Rate	Qty	Amount
Senior Technical Director	174.00	9.50	\$ 1,653.00
		9.50	\$ 1,653.00

3055000 104,354.00-00-000

Total Invoice Amount: \$ 1,653.00 ✓

OK to pay.  
3.12.18  
R2: Lonster P. P. P.  
Dicker Road Encroachment

Project Manager: M. Gerding

Task ID	Date	User ID	Employee Class	Billing Description	Pay Code	Qty	Bill Rate	Cost Amount	Bill Amount
---------	------	---------	----------------	---------------------	----------	-----	-----------	-------------	-------------

**M&H Project No: 17MH033 Dicker Road Hidalgo County**

**Professional Services**

ENG-PC-3	10/2/2017	gerdingm	Senior Technical Director	TC with Robert Garcia, discussion regarding status; update Dicker Road email to Colin	EXEMPT	2.50	174.00		435.00
	10/16/2017	gerdingm	Senior Technical Director	TC with DP & CH to discuss issues with TC+XDOT interface	EXEMPT	1.00	174.00		174.00
	10/17/2017	gerdingm	Senior Technical Director	prepare and transmit for review exception to 90 degree crossing, resend copy of cost estimates options A B & C to CH	EXEMPT	3.00	174.00		522.00
	10/23/2017	gerdingm	Senior Technical Director	prepare expanded submission with exhibits, forward to CH for internal review; break exhibits into seperate and added pipe data.	EXEMPT	3.00	174.00		522.00
				<b>Project Coordination - General</b>	<b>Task Totals</b>	<b>9.50</b>			<b>\$ 1,653.00</b>
				<b>Professional Services Total</b>		<b>9.50</b>			<b>\$ 1,653.00</b>

Total Invoice Amount: \$ 1,653.00

## Colin Harper

---

**From:** Katie Mullen <Katie.Mullen@mhes.com>  
**Sent:** Monday, March 12, 2018 9:00 AM  
**To:** Colin Harper  
**Cc:** Mark Gerding; Susanna Stewart  
**Subject:** M&H - Revised outstanding invoice  
**Attachments:** INV057940.pdf

Good morning Mr. Harper,  
Attached is our amended outstanding invoice for October.  
Please let me know if you have any additional questions.  
Kind regards,  
Katie Mullen

**Katie Mullen**  
281.664.7222 Office  
281.664.6826 Direct  
832.493.4370 Cell  
[katie.mullen@mhes.com](mailto:katie.mullen@mhes.com)  
[www.mhes.com](http://www.mhes.com)

APPROVED  
INVOICE  
ATTACHED



---

This email and any files transmitted with it are confidential and intended solely for the use of the individual or entity to whom they are addressed. If you are not the intended recipient you are notified that disclosing, copying, disseminating, distributing or taking any action in reliance on the contents of this information is strictly prohibited. Please notify the sender immediately by email if you have received this email by mistake and delete this email from your system. Any views or opinions presented in this email are solely those of the author and do not necessarily represent those of M&H Enterprises, Inc. The sender does not accept liability for any errors or omissions in the contents of this message which arise as a result of email transmission, nor for damage caused by any virus transmitted by this email.

---

This email has been scanned by the Symantec Email Security.cloud service.  
For more information please visit  
<http://www.message-labs.com/email>

---

344975



M&H Enterprises Inc.  
dba M&H Energy Services  
19450 HWY 249, Suite 600  
Houston, TX 77070  
(281) 664-7222

# INVOICE

**Bill To: CAMS Midstream**

Colin Harper  
919 Milam Street  
Suite 2300  
Houston, Texas 77002

Invoice Date: 3/12/2018  
Invoice No: INV058731  
Terms:

For services rendered for the calendar month ending **February 28, 2018**

**M&H Project No: 17MH033 Dicker Road Hidalgo County**

Inquiries can be sent to charper@camstex.com

**PROFESSIONAL SERVICES**

Senior Technical Director

Rate	Qty	Amount
174.00	6.00	\$ 1,044.00
	6.00	\$ 1,044.00

Total Invoice Amount: **\$ 1,044.00** ✓

3055000 104-354-00-00-000

208

*[Signature]* 3.13.18  
(REIMBURSABLE)  
R2:- Lorestar Pipeline  
- Dicker Road Encroachment

Project Manager: M. Gerding

Invoice No: **INV058731**

Task ID	Date	User ID	Employee Class	Billing Description	Pay Code	Qty	Bill Rate	Cost Amount	Bill Amount
---------	------	---------	----------------	---------------------	----------	-----	-----------	-------------	-------------

**M&H Project No: 17MH033 Dicker Road Hidalgo County**

**Professional Services**

<b>ENG-PC-3</b>	2/1/2018	gerdingm	Senior Technical Director	prep DUL	EXEMPT	3.00	174.00		522.00
	2/2/2018	gerdingm	Senior Technical Director	prep DUL	EXEMPT	3.00	174.00		522.00
				<b>Project Coordination - General</b>	<b>Task Totals</b>	<b>6.00</b>			<b>\$ 1,044.00</b>
				<b>Professional Services Total</b>		<b>6.00</b>			<b>\$ 1,044.00</b>

Total Invoice Amount: \$ 1,044.00



**CONSOLIDATED ASSET MANAGEMENT SERVICES, LLC**

919 Milam Street, Suite 2300 Houston, TX 77002-5418

TO: Lonestar Pipeline Company, LLC  
 c/o Frontera Energy Center  
 900 S Goodwin Road  
 Mission, TX 78572

Attention: Gener.Gotiangco  
[gener.gotiangco@kindle-energy.com](mailto:gener.gotiangco@kindle-energy.com)

Invoice No.: LONPIP 20180430  
 Date: 11-May-2018  
 Due Date: 26-May-2018  
 Prepared by: R.Wilson  
 713-358-9743

Pursuant to the terms of the Pipeline Services Agreement dated 11/1/2014 by and between Consolidated Asset Management Services, LLC ("CAMS") and Lonestar Pipeline Company, LLC (d/b/a Rio Grande Interstate Pipeline LLC) ("Lonestar"); Non-Routine fees per "Exhibit 1" to the above contract:

**Non-Routine Services:**

CAMS "Allocated Time for Colin Harper" related to the TRCC Field Audit

(see attached time allocation schedule)

Texas Railroad Commission - Field Audit	2.00	
Hours:	2.00	
Rate per Hour:	250.00	500.00

**Other Non-Routine Services:**

CAMS Trident - Locate & Mark Lines ( Inv# 060081 dated 4/30/18)	1,756.34
M&H Enterprises, Inc. - March Engineering Services (Inv# INV058951 dated 4/9/18) plus 15% markup	TxDOT Reimbursable 4,670.15
M&H Enterprises, Inc. - April Engineering Services (Inv# INV059175 dated 5/9/18) plus 15% markup	TxDOT Reimbursable 14,484.83
M&H Enterprises, Inc. - April Engineering Services (Inv# INV059181 dated 5/9/18) plus 15% markup	1,200.60
Majic Valley Electric - April electric for rectifiers ( Inv# 290790-APR dated 4/25/18)	74.41
Direct Energy -March electric ( Inv# 181020034319117 dated 4/12/18)	44.38
Direct Energy - April electric ( Inv# 181280034635015 dated 5/8/18)	41.36
Texas Excavation Safety System - March message fees ( Inv# 18-03774 dated 3/31/18)	53.20
Texas Excavation Safety System - April message fees ( Inv# 18-05862 dated 4/30/18)	44.65

**TOTAL AMOUNT DUE: \$ 22,869.92**

**Wire Instructions:**  
 Consolidated Asset Management  
 Services Texas, LLC  
 Amegy Bank  
 ABA#: 113011258  
 Account # 003771350

CO	Coding:		Subaccount				Amount
CAMSTEX	Acct						
LONPIP	1110000	104	000	00	00	0000	22,869.92
	1140000	104	000	00	00	0000	0.00
	3050000	104	354	00	00	0000	(500.00)
	3055000	104	354	00	00	0000	(22,369.92)

*R.Wilson*



M&H Enterprises Inc.  
 dba M&H Energy Services  
 19450 HWY 249, Suite 600  
 Houston, TX 77070  
 (281) 664-7222

344614

**INVOICE**

**Bill To: CAMS Midstream**

Colin Harper  
 919 Milam Street  
 Suite 2300  
 Houston, Texas 77002

B# 127070

Invoice Date: 4/9/2018  
 Invoice No: INV058951  
 Terms:

For services rendered for the calendar month ending **March 31, 2018**

**M&H Project No: 17MH033 Dicker Road Hidalgo County**  
 Inquiries can be sent to charper@camstex.com

**PROFESSIONAL SERVICES**

Designer 4  
 Senior Technical Director

	Rate	Qty	Amount
	115.00	17.00	\$ 1,955.00
	174.00	11.00	\$ 1,914.00
		28.00	\$ 3,869.00

**EXPENSES**

\$ 192.00

Total Invoice Amount: **\$ 4,061.00** ✓

3055000 104-354-00-00-000

**RECEIVED**  
 APR 16 2018  
 A/P DEPARTMENT

*[Signature]* 4.10.18  
 re: Loresta P. Poline  
 Dicker Road

*[Signature]*

Project Manager: M. Gerding

Task ID	Date	User ID	Employee Class	Billing Description	Pay Code	Qty	B II Rate	Cost Amount	Bill Amount
---------	------	---------	----------------	---------------------	----------	-----	-----------	-------------	-------------

**M&H Project No: 17MH033 Dicker Road Hidalgo County**

**Professional Services**

PL-AS-D	3/13/2018	coplenc	Designer 4	Prpeared Road Crossing Drawing	HOURLY	8.00	115.00		920.00
	3/15/2018	coplenc	Designer 4	Prepared Road Crossing Drawing	HOURLY	4.00	115.00		460.00
	3/16/2018	coplenc	Designer 4	Prepared Road Crossing Drawing	HOURLY	4.00	115.00		460.00
	3/21/2018	coplenc	Designer 4	Prepared Drawing for Issue	HOURLY	1.00	115.00		115.00
				<b>Alignment Sheets - AutoCAD Drawing</b>	<b>Task Totals</b>	<b>17.00</b>			<b>\$ 1,955.00</b>
PL-RC	3/5/2018	gerdingm	Senior Technical Director	Define Upper limit	EXEMPT	3.00	174.00		522.00
	3/6/2018	gerdingm	Senior Technical Director	DUL - define upper limit	EXEMPT	3.00	174.00		522.00
	3/7/2018	gerdingm	Senior Technical Director	work on DUL; project schedule & crossing plan & profile	EXEMPT	3.00	174.00		522.00
	3/9/2018	gerdingm	Senior Technical Director	MDS; STRIKE coordinate scope and confirm capabilities; work on DUL	EXEMPT	2.00	174.00		348.00
				<b>Road Crossing Exhibits</b>	<b>Task Totals</b>	<b>11.00</b>			<b>\$ 1,914.00</b>
<b>Professional Services Total</b>						<b>28.00</b>			<b>\$ 3,869.00</b>

**Expenses**

EXP - SOFTWARE	3/17/2018	Software	Software Charges	Software charge - CAD	EXP	16.00	12.000	192.00	192.00
				<b>Software - 12 CAD / 25 SACS</b>	<b>Task Totals</b>	<b>16.00</b>		192.00	<b>\$ 192.00</b>
<b>Expenses Total</b>						<b>16.00</b>			<b>\$ 192.00</b>

Total Invoice Amcunt: \$ 4,061.00



M&H Enterprises Inc.  
 dba M&H Energy Services  
 19450 HWY 249, Suite 600  
 Houston, TX 77070  
 (281) 664-7222

# INVOICE

**Bill To: CAMS Midstream**

Colin Harper  
 919 Milam Street  
 Suite 2300  
 Houston, Texas 77002

Invoice Date: 5/9/2018  
 Invoice No: INV059175  
 Terms:

For services rendered for the calendar month ending **April 30, 2018**

**M&H Project No: 17MH033 Dicker Road Hidalgo County**

Inquiries can be sent to charper@camstex.com

**PROFESSIONAL SERVICES**

	Rate	Qty	Amount
Designer 2	137.00	5.00	\$ 685.00
Designer 4	115.00	41.00	\$ 4,715.00
Project Controls Manager	115.00	4.50	\$ 517.50
Senior Purchasing Agent	120.00	0.50	\$ 60.00
Senior Technical Director	174.00	35.00	\$ 6,090.00
		86.00	\$ 12,067.50

**EXPENSES**

\$ 528.00

Total Invoice Amount: **\$ 12,595.50**

Project Manager: M. Gerding

*OK to pay - 5.10.18*  
*RE: LoneStar Pipeline*  
*TX DOT - Dicker Road Relocation Project.*

Task ID	Date	User ID	Employee Class	Billing Description	Pay Code	Qty	Bill Rate	Cost Amount	Bill Amount
---------	------	---------	----------------	---------------------	----------	-----	-----------	-------------	-------------

**M&H Project No: 17MH033 Dicker Road Hidalgo County**

**Professional Services**

<b>ENG-COST</b>	4/4/2018	gerdingm	Senior Technical Director	Cost estimate for detailed engineering phase; Dicker Road	EXEMPT	3.50	174.00		609.00
	4/9/2018	gerdingm	Senior Technical Director	cost estimate for change order	EXEMPT	2.00	174.00		348.00
	4/13/2018	gerdingm	Senior Technical Director	change order	EXEMPT	0.50	174.00		87.00
	4/18/2018	gerdingm	Senior Technical Director	revision of total installed cost estimate;	EXEMPT	2.00	174.00		348.00
	4/20/2018	gerdingm	Senior Technical Director	discussion with Strike construction, estimate volume and cost to dispose of drilling fluid; revision of total installed cost estimate; forward to Colin Harper for review	EXEMPT	4.00	174.00		696.00
	4/23/2018	gerdingm	Senior Technical Director	update cost estimate; contact several x-ray companies for day rates and understanding of their billing	EXEMPT	2.00	174.00		348.00
	4/24/2018	gerdingm	Senior Technical Director	revised cost estimate per CAMS initial review	EXEMPT	2.50	174.00		435.00
	4/4/2018	smithj	Designer 2	Dicker Road Pipeline Civil Cost Estimate	HOURLY	1.00	137.00		137.00
	4/5/2018	smithj	Designer 2	Dicker Road Hidalgo - Cost Estimate and Meeting	HOURLY	1.00	137.00		137.00
				<b>Cost Estimate</b>	<b>Task Totals</b>	<b>18.50</b>			<b>\$ 3,145.00</b> ✓
<b>ENG-PC-2</b>	4/5/2018	colliers	Project Controls Manager	change order development, PC coordination, meeting	EXEMPT	2.00	115.00		230.00
	4/12/2018	colliers	Project Controls Manager	wkly meeting, PC support	EXEMPT	1.00	115.00		115.00
	4/18/2018	colliers	Project Controls Manager	CO follow up, PC support	EXEMPT	0.50	115.00		57.50
	4/20/2018	colliers	Project Controls Manager	meeting, PC support	EXEMPT	0.50	115.00		57.50
	4/25/2018	colliers	Project Controls Manager	PCC support	EXEMPT	0.50	115.00		57.50
				<b>Project Coordination - Controls</b>	<b>Task Totals</b>	<b>4.50</b>			<b>\$ 517.50</b> ✓
<b>ENG-PC-3</b>	4/2/2018	gerdingm	Senior Technical Director	DUL prep	EXEMPT	6.00	174.00		1,044.00

Task ID	Date	User ID	Employee Class	Billing Description	Pay Code	Qty	Bill Rate	Cost Amount	Bill Amount
ENG-PC-3	4/2/2018	gerdingm	Senior Technical Director	discussion with Strike Construction regarding pending filed trip to work site	EXEMPT	1.00	174.00		174.00
	4/3/2018	gerdingm	Senior Technical Director	DUL prep;	EXEMPT	2.50	174.00		435.00
	4/5/2018	gerdingm	Senior Technical Director	prepare calc for revised road crossing design HDD	EXEMPT	1.00	174.00		174.00
	4/20/2018	gerdingm	Senior Technical Director	Change Order #2; prepare and forward to Colin Harper	EXEMPT	2.00	174.00		348.00
	4/6/2018	smiths	Senior Purchasing Agent	Getting material estimates on line pipe and fittings	EXEMPT	0.50	120.00		60.00
					<b>Project Coordination - General</b>	<b>Task Totals</b>	<b>13.00</b>		
ENG-PC-5	4/4/2018	gerdingm	Senior Technical Director	discussion with Hidalgo County rep; Anthony Garza	EXEMPT	0.50	174.00		87.00
	4/5/2018	gerdingm	Senior Technical Director	discussion with Strike construction; forwarded sketch of proposed crossing	EXEMPT	0.50	174.00		87.00
	4/5/2018	gerdingm	Senior Technical Director	project mtg.	EXEMPT	0.50	174.00		87.00
	4/5/2018	gerdingm	Senior Technical Director	meeting with Hidalgo County rep	EXEMPT	0.50	174.00		87.00
	4/12/2018	gerdingm	Senior Technical Director	weekly project meeting	EXEMPT	0.50	174.00		87.00
	4/12/2018	gerdingm	Senior Technical Director	TC with Anthony Garza with Hidalgo County	EXEMPT	0.50	174.00		87.00
				<b>Project Coordination - Meetings</b>	<b>Task Totals</b>	<b>3.00</b>			<b>\$ 522.00</b> ✓
PL-AS-D	4/5/2018	coplenc	Designer 4	Updated Plan and Profile	HOURLY	9.00	115.00		1,035.00
	4/6/2018	coplenc	Designer 4	Prepared Cover Sheet (1 hour) and Location Plan (4 hours)	HOURLY	5.00	115.00		575.00
	4/9/2018	coplenc	Designer 4	Plan and Profile Drawing	HOURLY	9.00	115.00		1,035.00
	4/10/2018	coplenc	Designer 4	Plan and Profile Drawing	HOURLY	7.00	115.00		805.00
	4/10/2018	coplenc	Designer 4	Cover Sheet	HOURLY	1.00	115.00		115.00
	4/10/2018	coplenc	Designer 4	Traffic Safety Plan	HOURLY	1.00	115.00		115.00
	4/11/2018	coplenc	Designer 4	Location Plan and General Notes	HOURLY	2.00	115.00		230.00
	4/11/2018	coplenc	Designer 4	Plan and Profile Drawing	HOURLY	4.00	115.00		460.00
	4/12/2018	coplenc	Designer 4	Updated (3) drawings for final Client review issue	HOURLY	3.00	115.00		345.00
	4/9/2018	smithj	Designer 2	DUL Plan and Profile	HOURLY	0.50	137.00		68.50
4/11/2018	smithj	Designer 2	Drawing Review EL7-9001, 9101, & 9201	HOURLY	1.00	137.00		137.00	

Task ID	Date	User ID	Employee Class	Billing Description	Pay Code	Qty	Bill Rate	Cost Amount	Bill Amount
PL-AS-D	4/12/2018	smithj	Designer 2	Pipeline DUL Package Review - ES7- 9001, 9101, 9201	HOURLY	0.50	137.00		68.50
				<b>Alignment Sheets - AutoCAD Drawing</b>	<b>Task Totals</b>	<b>43.00</b>		<b>\$ 4,989.00</b>	
PL-RC	4/9/2018	gerdingm	Senior Technical Director	revise crossing to HDD; perform HDD calculations to support drawing	EXEMPT	3.00	174.00		522.00
				<b>Road Crossing Exhibits</b>	<b>Task Totals</b>	<b>3.00</b>		<b>\$ 522.00</b>	
PL-RC-D	4/3/2018	smithj	Designer 2	Traffic Control Plan	HOURLY	1.00	137.00		137.00
				<b>Road Crossing Exhibits - AutoCAD Drawing</b>	<b>Task Totals</b>	<b>1.00</b>		<b>\$ 137.00</b>	
<b>Professional Services Total</b>						<b>86.00</b>			<b>\$ 12,067.50</b>

**Expenses**

EXP - SOFTWARE	4/7/2018	Software	Software Charges	Software charge - CAD	EXP	15.00	12.000	180.00	180.00
	4/14/2018	Software	Software Charges	Software charge - CAD	EXP	29.00	12.000	348.00	348.00
	<b>Software - 12 CAD / 25 SACS</b>				<b>Task Totals</b>	<b>44.00</b>		<b>528.00</b>	<b>\$ 528.00</b>
<b>Expenses Total</b>						<b>44.00</b>			<b>\$ 528.00</b>

Total Invoice Amount: \$ 12,595.50



**CONSOLIDATED ASSET MANAGEMENT SERVICES, LLC**

919 Milam Street, Suite 2300 Houston, TX 77002-5418

TO: Lonestar Pipeline Company, LLC  
 c/o Frontera Energy Center  
 900 S Goodwin Road  
 Mission, TX 78572

Attention: Gener.Gotiangco  
[gener.gotiangco@kindle-energy.com](mailto:gener.gotiangco@kindle-energy.com)

Invoice No.: LONPIP 20180531  
 Date: 11-Jun-2018  
 Due Date: 26-Jun-2018  
 Prepared by: R.Wilson 713-358-9743

Pursuant to the terms of the Pipeline Services Agreement dated 11/1/2014 by and between Consolidated Asset Management Services, LLC ("CAMS") and Lonestar Pipeline Company, LLC (d/b/a Rio Grande Interstate Pipeline LLC) ("Lonestar"); Non-Routine fees per "Exhibit 1" to the above contract:

**Non-Routine Services:**

CAMS "Allocated Time for Colin Harper" related to the TX DOT Line Relocation  
*(see attached time allocation schedule)*

Dicker Road - TX DOT - Line Relocation

	<b>2.75</b>	
Hours:	2.75	
Rate per Hour:	250.00	TxDOT Reimbursable <b>687.50</b>

**Other Non-Routine Services:**

CAMS Trident - Locate & Mark Lines ( Inv# 060599 dated 5/31/18)	4,664.95
US DOT - 2018 User Fee Assessment ( Inv# 20188-0520257 dated 5/24/18)	3,665.20
Majic Valley Electric - May electric for rectifiers ( Inv# 290790-MAY dated 5/25/18)	80.77
Direct Energy - May electric ( Inv# 181570034928969 dated 6/6/18)	42.52
Texas Excavation Safety System - May message fees ( Inv# 18-07472 dated 5/31/18)	44.65
USPS Trans#: 436189215 dated 5/31/18	6.70

**TOTAL AMOUNT DUE: \$ 9,192.29**

**Wire Instructions:**  
 Consolidated Asset Management  
 Services Texas, LLC  
 Amegy Bank  
 ABA#: 113011258  
 Account # 003771350

CO	Coding:							Amount
CAMSTEX	Acct		Subaccount					
LONPIP	1110000	104	000	00	00	0000		9,192.29
	1140000	104	000	00	00	0000		0.00
	3050000	104	354	00	00	0000		(687.50)
	3055000	104	354	00	00	0000		(8,504.79)

*R.Wilson*

**CAMS Time Allocation**

**Lonestar Pipeline O&M**

**Name: Colin Harper**

**Month: May 2017**

**Dicker Road - TX DOT - Line Relocation**

<b>21-May</b>	Search for TXDOT contract to determine status; prep for call with Kindle Energy Team regarding the project	<b>1.00</b>
<b>21-May</b>	Conf Call with Anthony Garza with L&G Engineering regarding TXDOT project and reimbursement processes	<b>0.50</b>
<b>21-May</b>	Conf Call with Kindle Energy Team (Gener, Grace, Julie, Ed) regarding the project status and next steps	<b>0.75</b>
<b>23-May</b>	Follow-up Call with Kindle Energy Team (Gener, Grace, Julie, Ed) regarding the project and the TXDOT pre-filing application process	<b>0.50</b>

**Total Dicker Road - May 2018** 2.75

**Total May 2018 Hours** 2.75



## CONSOLIDATED ASSET MANAGEMENT SERVICES, LLC

919 Milam Street, Suite 2300 Houston, TX 77002-5418

**TO: Lonestar Pipeline Company, LLC**  
 c/o Frontera Energy Center  
 900 S Goodwin Road  
 Mission, TX 78572

**Attention: Gener.Gotiangco**  
[gener.gotiangco@kindle-energy.com](mailto:gener.gotiangco@kindle-energy.com)

**Invoice No.:** LONPIP 20180630  
**Date:** 11-Jul-2018  
**Due Date:** 26-Jul-2018  
**Prepared by:** R.Wilson 713-358-9743

Pursuant to the terms of the Pipeline Services Agreement dated 11/1/2014 by and between Consolidated Asset Management Services, LLC ("CAMS") and Lonestar Pipeline Company, LLC (d/b/a Rio Grande Interstate Pipeline LLC) ("Lonestar"); Non-Routine fees per "Exhibit 1" to the above contract:

**Non-Routine Services:**

**CAMS "Allocated Time for Colin Harper" related to the TX DOT Line Relocation**

*(see attached time allocation schedule)*

Dicker Road - TX DOT - Line Relocation

	<b>0.50</b>		
<b>Hours:</b>	<b>0.50</b>		
<b>Rate per Hour:</b>	<b>250.00</b>	<b>TxDOT Reimbursable</b>	<b>125.00</b>

**Other Non-Routine Services:**

CAMS Trident - Locate & Mark Lines ( Inv# 061172 dated 6/30/18)	3,064.07
Texas Railroad Commision - 2018 Pipeline Mileage Fee (Inv# Notice060518 dated 6/05/18)	409.26
M&H Enterprises, Inc. - May Engineering Services (Inv# INV059457 dated 6/12/18) plus 15% markup	<b>1,600.80</b>
M&H Enterprises, Inc. - June. Engineering Services (Inv# INV059914 dated 7/9/18) plus 15% markup	<b>3,686.33</b>
Majic Valley Electric - June electric for rectifiers ( Inv# 290790-JUN dated 6/26/18)	84.92
Direct Energy - June electric ( Inv# 181840035216202 dated 7/2/18)	41.75
Direct Energy - May electric ( Inv# 181630034988639 dated 6/12/18)	9.83
Direct Energy - June electric ( Inv# 181900035259189 dated 7/9/18)	13.00
Texas Excavation Safety System - June message fees ( Inv# 18-09250 dated 6/30/18)	48.45

**TOTAL AMOUNT DUE: \$ 9,083.41**

**Wire Instructions:**  
 Consolidated Asset Management  
 Services Texas, LLC  
 Amegy Bank  
 ABA#: 113011258  
 Account # 003771350

CO	Coding:						Amount
CAMSTEX	Acct	Subaccount					
LONPIP	1110000	104	000	00	00	0000	9,083.41
	1140000	104	000	00	00	0000	0.00
	3050000	104	354	00	00	0000	(125.00)
	3055000	104	354	00	00	0000	(8,958.41)

**CAMS Time Allocation**

**Name: Colin Harper**

**Month: June 2017**

**Lonestar Pipeline O&M**

**Dicker Road - TD DOT - Line Relocation**

**25-Jun**

Call with Kindle Energy Team regarding update on the Dicker Road Project regarding the project

**0.50**

**Total Dicker Road - June 2018**

**0.50**

**Total June 2018 Hours**

**0.50**

COPY

INVOICE



M&H Enterprises Inc.  
dba M&H Energy Services  
19450 HWY 249, Suite 600  
Houston, TX 77070  
(281) 664-7222

Invoice Date: 6/12/2018  
Invoice No: INV059459  
Terms:

Bill To: CAMS Midstream

Colin Harper  
919 Milam Street  
Suite 2300  
Houston, Texas 77002

For services rendered for the calendar month ending **May 31, 2018**

M&H Project No: 17MH033 Dicker Road Hidalgo County

Inquiries can be sent to charper@camstex.com

PROFESSIONAL SERVICES

Senior Technical Director

Rate	Qty	Amount
174.00	8.00	\$ 1,392.00
	8.00	\$ 1,392.00

Total Invoice Amount: \$ 1,392.00 ✓

3055000 104-354-00-00-000

*[Signature]* 6.15.18  
R2: Lenester Pipeline  
Dicker Road Project

Project Manager: M. Gerding

Task ID	Date	User ID	Employee Class	Billing Description	Pay Code	Qty	Bill Rate	Cost Amount	Bill Amount
---------	------	---------	----------------	---------------------	----------	-----	-----------	-------------	-------------

**M&H Project No: 17MH033 Dicker Road Hidalgo County**

**Professional Services**

<b>ENG-PC-3</b>	5/23/2018	gerdingm	Senior Technical Director	DUL	EXEMPT	4.00	174.00		696.00
				<b>Project Coordination - General</b>	<b>Task Totals</b>	<b>4.00</b>			<b>\$ 696.00</b>
<b>ENG-PC-5</b>	5/22/2018	gerdingm	Senior Technical Director		EXEMPT	2.00	174.00		348.00
	5/23/2018	gerdingm	Senior Technical Director	meeting & prep	EXEMPT	2.00	174.00		348.00
				<b>Project Coordination - Meetings</b>	<b>Task Totals</b>	<b>4.00</b>			<b>\$ 696.00</b>
<b>Professional Services Total</b>						<b>8.00</b>			<b>\$ 1,392.00</b>

Total Invoice Amount: \$ 1,392.00



M&H Enterprises Inc.  
 dba M&H Energy Services  
 19450 HWY 249, Suite 600  
 Houston, TX 77070  
 (281) 664-7222

# INVOICE

**Bill To: CAMS Midstream**

Colin Harper  
 919 Milam Street  
 Suite 2300  
 Houston, Texas 77002

Invoice Date: 7/9/2018  
 Invoice No: INV059914  
 Terms:

For services rendered for the calendar month ending **June 30, 2018**

**M&H Project No: 17MH033 Dicker Road Hidalgo County**

Inquiries can be sent to charper@camstex.com

**PROFESSIONAL SERVICES**

Project Controls Cord. 3  
 Senior Technical Director

	Rate	Qty	Amount
	65.00	10.50	\$ 682.50
	174.00	14.50	\$ 2,523.00
		25.00	\$ 3,205.50

Total Invoice Amount: \$ 3,205.50 ✓

3055000 104-354-00-00-000

*[Signature]* 7.12.18  
 RE: Lonestar Pipeline  
 Dicker Road Relocation

Project Manager: M. Gerding

Task ID	Date	User ID	Employee Class	Billing Description	Pay Code	Qty	Bill Rate	Cost Amount	Bill Amount
---------	------	---------	----------------	---------------------	----------	-----	-----------	-------------	-------------

**M&H Project No: 17MH033 Dicker Road Hidalgo County**

**Professional Services**

<i>R. Linscomb</i> ✓	ENG-PC-2	6/19/2018	linscombek	Project Controls Cord. 3	Construction Spec Document Control	HOURLY	4.00	65.00 ✓	260.00
		6/20/2018	linscombek	Project Controls Cord. 3	DUL final review and submittal, Trans 0001	HOURLY	5.00	65.00	325.00
		6/21/2018	linscombek	Project Controls Cord. 3	Estimate revision, re-package and send	HOURLY	1.00	65.00	65.00
		6/26/2018	linscombek	Project Controls Cord. 3	DUL - Affidavit revision	HOURLY	0.50	65.00	32.50
				<b>Project Coordination - Controls</b>	<b>Task Totals</b>	<b>10.50 ✓</b>		<b>\$ 682.50 ✓</b>	
<i>MARG.</i> ✓	ENG-PC-3	6/15/2018	gerdingm	Senior Technical Director	DUL preparation	EXEMPT	8.00	174.00 ✓	1,392.00
		6/19/2018	gerdingm	Senior Technical Director	DUL preparation	EXEMPT	2.00	174.00	348.00
		6/20/2018	gerdingm	Senior Technical Director	review and update construction specification for DUL Update cost estimate	EXEMPT	3.00	174.00	522.00
		6/21/2018	gerdingm	Senior Technical Director	revise DUL esitmate	EXEMPT	0.50	174.00	87.00
		6/25/2018	gerdingm	Senior Technical Director	conferenc call with client to review DUL	EXEMPT	0.50	174.00	87.00
		6/26/2018	gerdingm	Senior Technical Director	update DUL per monday meeting with client	EXEMPT	0.50	174.00	87.00
				<b>Project Coordination - General</b>	<b>Task Totals</b>	<b>14.50 ✓</b>		<b>\$ 2,523.00 ✓</b>	
				<b>Professional Services Total</b>		<b>25.00</b>		<b>\$ 3,205.50</b>	

Total Invoice Amount: \$ 3,205.50



**CONSOLIDATED ASSET MANAGEMENT SERVICES, LLC**

919 Milam Street, Suite 2300 Houston, TX 77002-5418

TO: Lonestar Pipeline Company, LLC  
 c/o Frontera Energy Center  
 900 S Goodwin Road  
 Mission, TX 78572

Attention: Gener.Gotiangco  
[gener.gotiangco@kindle-energy.com](mailto:gener.gotiangco@kindle-energy.com)

Invoice No.: LONPIP 20180831  
 Date: 10-Sep-2018  
 Due Date: 25-Sep-2018  
 R. Wilson  
 Prepared by: 713-358-9743

Pursuant to the terms of the Pipeline Services Agreement dated 11/1/2014 by and between Consolidated Asset Management Services, LLC ("CAMS") and Lonestar Pipeline Company, LLC (d/b/a Rio Grande Interstate Pipeline LLC) ("Lonestar"); Non-Routine fees per "Exhibit 1" to the above contract:

**Non-Routine Services:**

CAMS "Allocated Time for Colin Harper" related to the TRCC Field Audit  
 (see attached time allocation schedule)

Texas Railroad Commission - Field Audit	1.25	
	Hours: 1.25	
	Rate per Hour: 250.00	312.50

**Other Non-Routine Services:**

CAMS Trident - Locate & Mark Lines ( Inv# 062165 dated 8/31/18)	2,102.97
CAMS Trident - La Frontera Plant Maintenance ( Inv# 062166 dated 8/31/18)	22,153.42
Texas Railroad Commision - Letter of Credit Fees (Inv# BankDebit dated 8/9/18)	175.00
SRP & Associates - Consulting & Expenses for TRCC Audit ( Inv# P-1 dated 8/10/18)	2,359.10
M&H Enterprises, Inc. - August Engineering Services (Inv# INV060130 dated 8/7/18) plus 15% markup	TxDOT Reimbursable 624.45
Majic Valley Electric - August electric for rectifiers ( Inv# 290790-AUG dated 8/27/18)	76.43
Direct Energy - August electric ( Inv# 182470035830017 dated 9/4/18)	41.56
Direct Energy - July electric ( Inv# 182190035561466 dated 8/7/18)	12.12
Direct Energy - August electric ( Inv# 182480035848398 dated 9/5/18)	12.40
UPS Inv#: 53R7R8338 dated 8/18/18	11.11

**TOTAL AMOUNT DUE:** \$ 27,881.06

**Wire Instructions:**  
 Consolidated Asset Management  
 Services Texas, LLC  
 Amegy Bank  
 ABA#: 113011258  
 Account # 003771350

CO	Coding:						Amount
CAMSTEX	Acct	Subaccount					
LONPIP	1110000	104	000	00	00	0000	27,881.06
	1140000	104	000	00	00	0000	0.00
	3050000	104	354	00	00	0000	(312.50)
	3055000	104	354	00	00	0000	(27,568.56)



M&H Enterprises Inc.  
 dba M&H Energy Services  
 19450 HWY 249, Suite 600  
 Houston, TX 77070  
 (281) 664-7222

**COPY**

**INVOICE**

**Bill To: CAMS Midstream**

Colin Harper  
 919 Milam Street  
 Suite 2300  
 Houston, Texas 77002

Invoice Date: 8/7/2018  
 Invoice No: INV060130  
 Terms:

For services rendered for the calendar month ending **July 31, 2018**

**M&H Project No: 17MH033 Dicker Road Hidalgo County**

Inquiries can be sent to charper@camstex.com

**PROFESSIONAL SERVICES**

Project Controls Cord. 3  
 Senior Technical Director

Rate	Qty	Amount
65.00	3.00	\$ 195.00
174.00	2.00	\$ 348.00
	5.00	\$ 543.00

Total Invoice Amount: \$ 543.00 ✓

3055000 104-354-00-00-000

*[Signature]* 8.10.18  
 P2: LoneStar Pipeline  
 Dicker Road Relocation

Project Manager: M. Gerding

Task ID	Date	User ID	Employee Class	Billing Description	Pay Code	Qty	Bill Rate	Cost Amount	Bill Amount
---------	------	---------	----------------	---------------------	----------	-----	-----------	-------------	-------------

**M&H Project No: 17MH033 Dicker Road Hidalgo County**

**Professional Services**

<b>ENG-PC-2</b>	7/5/2018	linscombek	Project Controls Cord. 3	DUL revision coordination	HOURLY	1.50	65.00	97.50	✓
	7/10/2018	linscombek	Project Controls Cord. 3	DUL and Estimate Update	HOURLY	1.50	65.00	97.50	✓
<b>Project Coordination - Controls</b>						<b>Task Totals</b>	<b>3.00</b>	<b>\$ 195.00</b>	✓
<b>ENG-PC-3</b>	7/9/2018	gerdingm	Senior Technical Director	update cost estimate per county request	EXEMPT	1.00	174.00	174.00	✓
	7/10/2018	gerdingm	Senior Technical Director	finalize amended DUL; update estimate per Garza, add cost sheet; revoew amended DUL & transmit	EXEMPT	1.00	174.00	174.00	✓
<b>Project Coordination - General</b>						<b>Task Totals</b>	<b>2.00</b>	<b>\$ 348.00</b>	✓
<b>Professional Services Total</b>						<b>5.00</b>		<b>\$ 543.00</b>	✓

Total Invoice Amount: \$ 543.00



**CONSOLIDATED ASSET MANAGEMENT SERVICES, LLC**

919 Milam Street, Suite 2300 Houston, TX 77002-5418

**TO: Lonestar Pipeline Company, LLC**  
 c/o Frontera Energy Center  
 900 S Goodwin Road  
 Mission, TX 78572

**Attention: Gener.Gotiangco**  
[gener.gotiangco@kindle-energy.com](mailto:gener.gotiangco@kindle-energy.com)

**Invoice No.:** LONPIP 20180930  
**Date:** 10-Oct-2018  
**Due Date:** 25-Oct-2018  
 R.Wilson  
**Prepared by:** 713-358-9743

Pursuant to the terms of the Pipeline Services Agreement dated 11/1/2014 by and between Consolidated Asset Management Services, LLC ("CAMS") and Lonestar Pipeline Company, LLC (d/b/a Rio Grande Interstate Pipeline LLC) ("Lonestar"); Non-Routine fees per "Exhibit 1" to the above contract:

**Non-Routine Services:**

**CAMS "Allocated Time for Colin Harper" related to Various Encroachments**  
*(see attached time allocation schedule)*

Encroachments	3.00	
	<b>Hours:</b>	3.00
	<b>Rate per Hour:</b>	250.00
		<b>750.00</b>

**Other Non-Routine Services:**

CAMS Trident - Locate & Mark Lines ( Inv# 062623 dated 9/30/18)	3,083.74
Enertech - 2017 Public Awareness Liaison Program for Hidalgo County (Inv# INV-00557 dated 9/14/18)	600.00
Enertech - 2018 Public Awareness Liaison Program for Hidalgo County (Inv# INV-00558 dated 9/14/18)	400.00
Joy Toups - Credit card charge to TRRC for P-5 report filing	575.41
UPS charges to TRRC for P-5 report filing (Inv# 53R7R8378 dated 9/15/18)	15.90
M&H Enterprises, Inc. - September Engineering Services (Inv# INV060334 dated 9/11/18) plus 15% mark	6,233.58
Majic Valley Electric - September electric for rectifiers ( Inv# 290790-SEP dated 9/27/18)	74.54
Direct Energy - September electric ( Inv# 182750036122261 dated 10/2/18)	41.66
Direct Energy - September electric ( Inv# 182780036160263 dated 10/5/18)	12.12
Texas Excavation Safety System - August message fees ( Inv# 18-12993 dated 8/31/18)	78.85
Texas Excavation Safety System - September message fees ( Inv# 18-14787 dated 9/30/18)	70.30

TxDOT  
Reimbursable

**TOTAL AMOUNT DUE:**

**\$ 11,936.10**

**Wire Instructions:**  
 Consolidated Asset Management  
 Services Texas, LLC  
 Amegy Bank  
 ABA#: 113011258  
 Account # 003771350

CO	Coding:				Amount
CAMSTEX	Acct		Subaccount		
LONPIP	1110000	104	000	00 00 0000	11,936.10
	1140000	104	000	00 00 0000	0.00
	3050000	104	354	00 00 0000	(750.00)
	3055000	104	354	00 00 0000	(11,186.10)

*Handwritten signature/initials*



M&H Enterprises Inc.  
 dba M&H Energy Services  
 19450 HWY 249, Suite 600  
 Houston, TX 77070  
 (281) 664-7222

# INVOICE

**Bill To: CAMS Midstream**

Colin Harper  
 919 Milam Street  
 Suite 2300  
 Houston, Texas 77002

Invoice Date: 9/11/2018  
 Invoice No: INV060334  
 Terms:

For services rendered for the calendar month ending **August 31, 2018**

**M&H Project No: 17MH033 Dicker Road Hidalgo County**

Inquiries can be sent to charper@camstex.com

**PROFESSIONAL SERVICES**

	Rate	Qty	Amount
Designer 1	137.00	4.50	\$ 616.50
Designer 3	115.00	0.50	\$ 57.50
Project Controls Cord. 3	65.00	2.50	\$ 162.50
Senior Technical Director	174.00	26.00	\$ 4,524.00
		33.50	\$ 5,360.50

**EXPENSES**

\$ 60.00

Total Invoice Amount: **\$ 5,420.50** ✓

3055000 104-354-00-00-000

*[Signature]* 9.14.18  
 RZ: Loreta F. [Signature]  
 Dicker Road

Project Manager: M. Gerding

Task ID	Date	User ID	Employee Class	Billing Description	Pay Code	Qty	Bill Rate	Cost Amount	Bill Amount
---------	------	---------	----------------	---------------------	----------	-----	-----------	-------------	-------------

**M&H Project No: 17MH033 Dicker Road Hidalgo County**

**Professional Services**

<b>ENG-COST</b>	8/16/2018	gerdingm	Senior Technical Director		EXEMPT	4.00	174.00		696.00
	8/17/2018	gerdingm	Senior Technical Director	Update DUL	EXEMPT	4.00	174.00		696.00
	8/27/2018	gerdingm	Senior Technical Director		EXEMPT	4.00	174.00		696.00
	8/28/2018	gerdingm	Senior Technical Director	HDD drawing update to drafting and review	EXEMPT	1.00	174.00		174.00
	8/29/2018	gerdingm	Senior Technical Director		EXEMPT	4.00	174.00		696.00
	8/31/2018	gerdingm	Senior Technical Director		EXEMPT	3.00	174.00		522.00
				<b>Cost Estimate</b>	<b>Task Totals</b>	<b>20.00</b>			<b>\$ 3,480.00</b>
<b>ENG-PC-2</b>	8/17/2018	linscombek	Project Controls Cord. 3	Update excel document and add to Sharepoint	HOURLY	1.00	65.00		65.00
	8/29/2018	linscombek	Project Controls Cord. 3	Prep and Meeting: capture DUL comments, update as needed	HOURLY	1.50	65.00		97.50
				<b>Project Coordination - Controls</b>	<b>Task Totals</b>	<b>2.50</b>			<b>\$ 162.50</b>
<b>ENG-PC-3</b>	8/20/2018	gerdingm	Senior Technical Director	update cost estimate and DUL	EXEMPT	1.00	174.00		174.00
	8/22/2018	gerdingm	Senior Technical Director	update cost estimate and DUL	EXEMPT	1.00	174.00		174.00
	8/24/2018	gerdingm	Senior Technical Director	update cost estimate and DUL	EXEMPT	4.00	174.00		696.00
				<b>Project Coordination - General</b>	<b>Task Totals</b>	<b>6.00</b>			<b>\$ 1,044.00</b>
<b>PL-AS-D</b>	8/27/2018	smithj	Designer 1	Added pipeline and roadway station to alignment sheet	HOURLY	4.00	137.00		548.00
	8/29/2018	smithj	Designer 1	Typical Roadway HDD Crossing	HOURLY	0.50	137.00		68.50
				<b>Alignment Sheets - AutoCAD Drawing</b>	<b>Task Totals</b>	<b>4.50</b>			<b>\$ 616.50</b>
<b>PL-RC-D</b>	8/28/2018	coplenc	Designer 3	Modified Crossing drawing	HOURLY	0.50	115.00		57.50
				<b>Road Crossing Exhibits - AutoCAD Drawing</b>	<b>Task Totals</b>	<b>0.50</b>			<b>\$ 57.50</b>

Task ID	Date	User ID	Employee Class	Billing Description	Pay Code	Qty	Bill Rate	Cost Amount	Bill Amount
---------	------	---------	----------------	---------------------	----------	-----	-----------	-------------	-------------

<b>Professional Services Total</b>						<b>33.50</b>			<b>\$ 5,360.50</b>
------------------------------------	--	--	--	--	--	--------------	--	--	--------------------

**Expenses**

<b>EXP - SOFTWARE</b>	8/31/2018	Software	Software Charges	Software charge - CAD	EXP	5.00	12.000	60.00	60.00
-----------------------	-----------	----------	------------------	-----------------------	-----	------	--------	-------	-------

				<b>Software - 12 CAD / 25 SACS</b>	<b>Task Totals</b>	5.00		60.00	<b>\$ 60.00</b>
--	--	--	--	------------------------------------	--------------------	------	--	-------	-----------------

<b>Expenses Total</b>						<b>5.00</b>			<b>\$ 60.00</b>
-----------------------	--	--	--	--	--	-------------	--	--	-----------------

Total Invoice Amount: \$ 5,420.50



**CONSOLIDATED ASSET MANAGEMENT SERVICES, LLC**

919 Milam Street, Suite 2300 Houston, TX 77002-5418

TO: Lonestar Pipeline Company, LLC  
 c/o Frontera Energy Center  
 900 S Goodwin Road  
 Mission, TX 78572

Attention: Gener.Gotiangco  
[gener.gotiangco@kindle-energy.com](mailto:gener.gotiangco@kindle-energy.com)

Invoice No.: LONPIP 20181031  
 Date: 12-Nov-2018  
 Due Date: 27-Nov-2018  
 Prepared by: R.Wilson 713-358-9743

Pursuant to the terms of the Pipeline Services Agreement dated 11/1/2014 by and between Consolidated Asset Management Services, LLC ("CAMS") and Lonestar Pipeline Company, LLC (d/b/a Rio Grande Interstate Pipeline LLC) ("Lonestar"); Non-Routine fees per "Exhibit 1" to the above contract:

**Non-Routine Services:**

CAMS "Allocated Time for Colin Harper" related to TRCC Field Audit

(see attached time allocation schedule)

TRRC Audit	2.00	
Hours:	2.00	
Rate per Hour:	250.00	500.00

**Other Non-Routine Services:**

CAMS Trident - Locate & Mark Lines ( Inv# 063158 dated 10/31/18)	2,864.14
CAMS Trident - La Frontera Plant Leak ( Inv# 063159 dated 10/31/18)	681.08
Enertech - Est Postage for 2018 Pipeline Mailing (Inv# POST-00223 dated 10/26/18) plus 15% markup	1,525.82
M&H Enterprises, Inc. - September Engineering Services (Inv# INV060627 dated 10/9/18) plus 15% markup	2,625.45
M&H Enterprises, Inc. - October Engineering Services (Inv# INV060848 dated 11/1/18) plus 15% markup	1,276.50
Majic Valley Electric - Octoberber electric for rectifiers ( Inv# 290790-OCT dated 10/29/18)	74.68
Direct Energy - October electric ( Inv# 183060036434945 dated 11/2/18)	42.98
Direct Energy - October electric ( Inv# 183100036470804 dated 11/6/18)	2.12
Texas Excavation Safety System - October message fees ( Inv# 18-16784 dated 10/31/18)	69.35

TxDOT Reimbursable

TOTAL AMOUNT DUE: \$ 9,662.12

**Wire Instructions:**  
 Consolidated Asset Management  
 Services Texas, LLC  
 Amegy Bank  
 ABA#: 113011258  
 Account # 003771350

CO	Coding:						Amount
CAMSTEX	Acct		Subaccount				
LONPIP	1110000	104	000	00	00	0000	9,662.12
	1140000	104	000	00	00	0000	0.00
	3050000	104	354	00	00	0000	(500.00)
	3055000	104	354	00	00	0000	(9,162.12)

*Handwritten initials/signature*

359156



M&H Enterprises Inc.  
dba M&H Energy Services  
19450 HWY 249, Suite 600  
Houston, TX 77070  
(281) 664-7222

# INVOICE

**Bill To: CAMS Midstream**

Colin Harper  
919 Milam Street  
Suite 2300  
Houston, Texas 77002

Invoice Date: 10/9/2018  
Invoice No: INV060627  
Terms:

For services rendered for the calendar month ending **September 30, 2018**

**M&H Project No: 17MH033 Dicker Road Hidalgo County** ✓

Inquiries can be sent to charper@camstex.com

**PROFESSIONAL SERVICES**

Project Controls Coordinator 3  
Senior Technical Director

	Rate	Qty	Amount
	65.00	3.00	\$ 195.00
	174.00	12.00	\$ 2,088.00
		15.00	\$ 2,283.00

3055000 104-354-00-00-000

Total Invoice Amount: **\$ 2,283.00** ✓

RECEIVED  
OCT 16 2018  
A/P DEPARTMENT

*[Handwritten signature]*

*[Handwritten signature]*  
R2: LONESTAR  
DICKER ROAD

Project Manager: M. Gerding

Task ID	Date	User ID	Employee Class	Billing Description	Pay Code	Qty	Bill Rate	Cost Amount	Bill Amount
---------	------	---------	----------------	---------------------	----------	-----	-----------	-------------	-------------

**M&H Project No: 17MH033 Dicker Road Hidalgo County**

**Professional Services**

<b>ENG-COST</b>	9/13/2018	gerdingm	Senior Technical Director	Call for to Denso for cost for girth weld material; cost for asbestos testing; cost estimate update ✓	EXEMPT	4.00	174.00 ✓		696.00
	9/14/2018	gerdingm	Senior Technical Director	cost estimate completed ans sent to Colin ✓	EXEMPT	8.00	174.00		1,392.00
			<b>Cost Estimate</b>	<b>Task Totals</b>		<b>12.00</b>			<b>\$ 2,088.00</b>
<b>ENG-PC-2</b>	9/10/2018	linscombek	Project Controls Coordinator 3	DUL updates / correspondence ✓	HOURLY	2.00	65.00 ✓		130.00
	9/18/2018	linscombek	Project Controls Coordinator 3	Discussed DUL update plan with Mark ✓	HOURLY	1.00	65.00		65.00
			<b>Project Coordination - Controls</b>	<b>Task Totals</b>		<b>3.00</b>			<b>\$ 195.00</b>
			<b>Professional Services Total</b>			<b>15.00</b>			<b>\$ 2,283.00 ✓</b>

Total Invoice Amount: \$ 2,283.00



**CONSOLIDATED ASSET MANAGEMENT SERVICES, LLC**

919 Milam Street, Suite 2300 Houston, TX 77002-5418

TO: Lonestar Pipeline Company, LLC  
 c/o Frontera Energy Center  
 900 S Goodwin Road  
 Mission, TX 78572

Attention: Gener.Gotiangco  
[gener.gotiangco@kindle-energy.com](mailto:gener.gotiangco@kindle-energy.com)

Invoice No.: LONPIP 20190131  
 Date: 13-Feb-2019  
 Due Date: 28-Feb-2019  
 Prepared by: R.Wilson  
 713-358-9743

Pursuant to the terms of the Pipeline Services Agreement dated 11/1/2014 by and between Consolidated Asset Management Services, LLC ("CAMS") and Lonestar Pipeline Company, LLC (d/b/a Rio Grande Interstate Pipeline LLC) ("Lonestar"); Non-Routine fees per "Exhibit 1" to the above contract:

**Non-Routine Services:**

CAMS "Allocated Time for Colin Harper" related to TRCC Field Audit

(see attached time allocation schedule)

TRCC Audit	13.25	
Hours:	13.25	
Rate per Hour:	250.00	3,312.50

**Other Non-Routine Services:**

CAMS Trident - Locate & Mark Lines ( Inv# 064611 dated 1/31/19)	3,002.77
CAMS Trident - Pipeline Signs ( Inv# 064612 dated 1/31/19)	1,344.35
Enertech - Sarita 2019 Public Awareness Liaison Program (Inv# INV-00786 dated 2/06/19)	460.00
Enertech - BRC Postage for 2018 Pipeline Mailing (Inv# INV-00812 dated 1/22/19) plus 15% markup	30.43
Enertech - 2019 Xchange Hosting Fee (Inv# INV-00773 dated 1/15/19)	143.75
Colin Harper - Meal Expense for TRCC Audit Prep - Expense Report dated 2/01/19	44.50
UPS charges to OD Oilfield for Pipeline Brochures (Inv# 53R7R8029 dated 1/12/19)	25.80
SRP & Associates - Consulting & Expenses for TRCC Audit ( Inv# P-1 dated 2/1/19)	13,842.11
M&H Enterprises, Inc. - January Engineering Services (Inv# INV061836 dated 2/11/19) plus 15% markup <span style="color: red;">TxDOT Reimbursable</span>	<b>1,187.38</b>
Majic Valley Electric - January electric for rectifiers ( Inv# 290790-JAN dated 1/28/19)	75.89
Direct Energy - January electric ( Inv# 190360037343797 dated 2/4/19)	40.17
Direct Energy - January electric ( Inv# 190360037343796 dated 2/4/19)	12.25
Texas Excavation Safety System - January message fees ( Inv# 19-1969 dated 1/31/19)	57.95

**TOTAL AMOUNT DUE: \$ 23,579.85**

**Wire Instructions:**  
 Consolidated Asset Management  
 Services Texas, LLC  
 Amegy Bank  
 ABA#: 113011258  
 Account # 003771350

CO	Coding:		Subaccount				Amount
CAMSTEX	Acct						
LONPIP	1110000	104	000	00	00	0000	23,579.85
	1140000	104	000	00	00	0000	0.00
	3050000	104	354	00	00	0000	(3,312.50)
	3055000	104	354	00	00	0000	(20,267.35)



M&H Enterprises Inc.  
 dba M&H Energy Services  
 19450 HWY 249, Suite 600  
 Houston, TX 77070  
 (281) 664-7222

# INVOICE

**Bill To: CAMS Midstream**

Colin Harper  
 919 Milam Street  
 Suite 2300  
 Houston, Texas 77002

Invoice Date: 2/11/2019  
 Invoice No: INV061836  
 Terms:

For services rendered for the calendar month ending **January 31, 2019**

**M&H Project No: 17MH033 Dicker Road Hidalgo County** ✓

Inquiries can be sent to charper@camstex.com

**PROFESSIONAL SERVICES**

Project Controls Coordinator 3  
 Senior Technical Director

	Rate	Qty	Amount
	65.00	2.50	\$ 162.50
	174.00	5.00	\$ 870.00
		7.50	\$ 1,032.50

Total Invoice Amount: \$ 1,032.50 ✓

3055000 104-354-00-00-000

OK to pay.  
 2.13.19  
 re: Horstar Pipeline  
Dicker Road

Project Manager: M. Gerding

Task ID	Date	User ID	Employee Class	Billing Description	Pay Code	Qty	Bill Rate	Cost Amount	Bill Amount
---------	------	---------	----------------	---------------------	----------	-----	-----------	-------------	-------------

**M&H Project No: 17MH033 Dicker Road Hidalgo County**

**Professional Services**

<b>ENG-PC-2</b>	1/16/2019	linscombek ✓	Project Controls Coordinator 3	Transmittal 4, PDF and upload DUL	HOURLY	1.50	65.00		97.50
	1/17/2019	linscombek ✓	Project Controls Coordinator 3	Transmittal - send to client and upload	HOURLY	1.00	65.00 ✓		65.00
				<b>Project Coordination - Controls</b>	<b>Task Totals</b>	<b>2.50 ✓</b>			<b>\$ 162.50</b>
<b>ENG-PC-3</b>	1/17/2019	gerdingm ✓	Senior Technical Director	TXDOT DUL modifications for L&G	EXEMPT	4.00	174.00		696.00
	1/18/2019	gerdingm ✓	Senior Technical Director	TXDOT DUL modifications for L&G	EXEMPT	1.00	174.00 ✓		174.00
				<b>Project Coordination - General</b>	<b>Task Totals</b>	<b>5.00 ✓</b>			<b>\$ 870.00</b>
				<b>Professional Services Total</b>		<b>7.50</b>			<b>\$ 1,032.50</b>

Total Invoice Amount: \$ 1,032.50 ✓



**CONSOLIDATED ASSET MANAGEMENT SERVICES, LLC**

919 Milam Street, Suite 2300 Houston, TX 77002-5418

TO: Lonestar Pipeline Company, LLC  
 c/o Frontera Energy Center  
 900 S Goodwin Road  
 Mission, TX 78572

Attention: Gener.Gotiangco  
[gener.gotiangco@kindle-energy.com](mailto:gener.gotiangco@kindle-energy.com)

Invoice No.: LONPIP 20190228  
 Date: 13-Mar-2019  
 Due Date: 28-Mar-2019  
 Prepared by: R.Wilson  
 713-358-9743

Pursuant to the terms of the Pipeline Services Agreement dated 11/1/2014 by and between Consolidated Asset Management Services, LLC ("CAMS") and Lonestar Pipeline Company, LLC (d/b/a Rio Grande Interstate Pipeline LLC) ("Lonestar"); Non-Routine fees per "Exhibit 1" to the above contract:

**Non-Routine Services:**

CAMS "Allocated Time for Colin Harper" related to TRCC Field Audit

(see attached time allocation schedule)

TRRC Audit	1.25	
Hours:	1.25	
Rate per Hour:	250.00	312.50

**Other Non-Routine Services:**

CAMS Trident - Locate & Mark Lines ( Inv# 065021 dated 2/28/19)	5,724.99
Texas Railroad Commision - Annual Pipeline Mileage Fee (Inv# Notice021119 dated 2/11/19)	409.26
Texas Railroad Commision - P5 Renewal Filing (Inv# P-5 Lonestar dated 2/4/19)	511.51
M&H Enterprises, Inc. - December Engineering Services (Inv# INV061836 dated 2/11/19) plus 15% marku	2,601.30
M&H Enterprises, Inc. - December Engineering Services (Inv# INV060848 dated 11/1/18) plus 15% marku	212.75
Majic Valley Electric - February electric for rectifiers ( Inv# 290790-FEB dated 2/26/19)	78.18
Direct Energy - February electric ( Inv# 190640037636330 dated 3/5/19)	40.35
Direct Energy - February electric ( Inv# 190670037676746 dated 3/8/19)	12.12
Texas Excavation Safety System - February message fees ( Inv# 19-3525 dated 2/28/19)	59.85

TxDOT Reimbursable

**TOTAL AMOUNT DUE:**

**\$ 9,962.81**

**Wire Instructions:**  
 Consolidated Asset Management  
 Services Texas, LLC  
 Amegy Bank  
 ABA#: 113011258  
 Account # 003771350

CO	Coding:						Amount
CAMSTEX	Acct		Subaccount				
LONPIP	1110000	104	000	00	00	0000	9,962.81
	1140000	104	000	00	00	0000	0.00
	3050000	104	354	00	00	0000	(312.50)
	3055000	104	354	00	00	0000	(9,650.31)



M&H Enterprises Inc.  
 dba M&H Energy Services  
 19450 HWY 249, Suite 600  
 Houston, TX 77070  
 (281) 664-7222

# INVOICE

**Bill To: CAMS Midstream**

Colin Harper  
 919 Milam Street  
 Suite 2300  
 Houston, Texas 77002

Invoice Date: 1/14/2019  
 Invoice No: INV061539  
 Terms:

For services rendered for the calendar month ending **December 31, 2018**

**M&H Project No: 17MH033 Dicker Road Hidalgo County**

Inquiries can be sent to charper@camstex.com

**PROFESSIONAL SERVICES**

Senior Technical Director

Rate	Qty	Amount
174.00	13.00	\$ 2,262.00
	13.00	\$ 2,262.00

Total Invoice Amount: \$ 2,262.00

3055000 104-354-00-00-000

*[Signature]* 1.16.19  
 R2: Kenneth Pizulin  
 Dicker Road Enercoast

Project Manager: M. Gerding

Task ID	Date	User ID	Employee Class	Billing Description	Pay Code	Qty	Bill Rate	Cost Amount	Bill Amount
---------	------	---------	----------------	---------------------	----------	-----	-----------	-------------	-------------

**M&H Project No: 17MH033 Dicker Road Hidalgo County**

**Professional Services**

ENG-PC-3	12/7/2018	gerdingm	Senior Technical Director	update DUL for TXDOT	EXEMPT	5.00	174.00		870.00
	12/20/2018	gerdingm	Senior Technical Director		EXEMPT	4.00	174.00		696.00
	12/21/2018	gerdingm	Senior Technical Director		EXEMPT	4.00	174.00		696.00
<b>Project Coordination - General</b>					<b>Task Totals</b>	<b>13.00</b>			<b>\$ 2,262.00</b>
<b>Professional Services Total</b>						<b>13.00</b>			<b>\$ 2,262.00</b>

Total Invoice Amount: \$ 2,262.00



**CONSOLIDATED ASSET MANAGEMENT SERVICES, LLC**

919 Milam Street, Suite 2300 Houston, TX 77002-5418

TO: Lonestar Pipeline Company, LLC  
 c/o Frontera Energy Center  
 900 S Goodwin Road  
 Mission, TX 78572

Attention: Gener.Gotiangco  
[gener.gotiangco@kindle-energy.com](mailto:gener.gotiangco@kindle-energy.com)

Invoice No.: LONPIP 20190331  
 Date: 11-Apr-2019  
 Due Date: 26-Apr-2019  
 Prepared by: R.Wilson 713-358-9743

Pursuant to the terms of the Pipeline Services Agreement dated 11/1/2014 by and between Consolidated Asset Management Services, LLC ("CAMS") and Lonestar Pipeline Company, LLC (d/b/a Rio Grande Interstate Pipeline LLC) ("Lonestar"); Non-Routine fees per "Exhibit 1" to the above contract:

**Non-Routine Services:**

**CAMS "Allocated Time for Colin Harper" related to the Hwy 83 Cable Barrier Project**  
*(see attached time allocation schedule)*

Tx Dot Hwy 83 Cable Barrier Project - March	2.50		
Hours:	2.50		
Rate per Hour:	250.00	625.00	

**CAMS "Allocated Time for Colin Harper" related to the Dicker Road Line Relocation**  
*(see attached time allocation schedule)*

Tx Dot Dicker Road Line Relocation - March	6.50		
Hours:	6.50		
Rate per Hour:	250.00	1,625.00	TxDOT Reimbursable

**Other Non-Routine Services:**

CAMS Trident - Locate & Mark Lines ( Inv# 065507 dated 3/29/19)	4,456.16	
US DOT - 2019 User Fee Assessment ( Inv# 20198-030080 dated 3/29/19)	6,847.40	
M&H Enterprises, Inc. - February Engineering Services (Inv# INV062127 dated 3/7/19) plus 15% markup	149.50	TxDOT Reimbursable
Majic Valley Electric - March electric for rectifiers ( Inv# 290790-MAR dated 3/26/19)	76.34	
Direct Energy - March electric ( Inv# 190990038001846 dated 4/9/19)	42.31	
Direct Energy - March electric ( Inv# 190990038001845 dated 4/9/19)	12.12	
Texas Excavation Safety System - March message fees ( Inv# 19-5376 dated 3/31/19)	49.40	
Texas Excavation Safety System - Board of Texas Class A fee ( Inv# 19-7138 dated 4/5/19)	50.00	

**TOTAL AMOUNT DUE:** \$ 13,933.23

**Wire Instructions:**  
 Consolidated Asset Management  
 Services Texas, LLC  
 Amegy Bank  
 ABA#: 113011258  
 Account # 003771350

CO	Coding:						Amount
CAMSTEX	Acct	Subaccount					
LONPIP	1110000	104	000	00	00	0000	13,933.23
	1140000	104	000	00	00	0000	0.00
	3050000	104	354	00	00	0000	(2,250.00)
	3055000	104	354	00	00	0000	(11,683.23)

**CAMS Time Allocation**  
**Name: Colin Harper**  
**Month: March 2019**

**Lonestar Pipeline O&M**

<u>Tx DOT - Hwy 83 Cable Barrier Project</u>		<u>Time/ Hrs.</u>
11-Mar	Call with Hazel at TX DOT regarding project and possible conflict with the Lonestar Pipeline	0.25
12-Mar	Call with Mark Gerding at M&H regarding TX DOT Cable Project and possible conflict with LSPL; Mark provided info request from TX DOT	0.75
19-Mar	Worked with Ricky Lay (Trident) and Mark Gerding to provide exact location of LSPL to TX DOT for clearing of any potential conflict	0.75
22-Mar	Calls and e-mails with M&H and TX DOT regarding the location of LSPL and our request for TX DOT to avoid the pipeline during its project by setting posts several feet before and after the pipeline crossing. Also requested notification (811) as they approach the pipeline so that we can have an inspector on site	0.75
<b>TX DOT Cable Barrier Project Total</b>		<b>2.5</b>

<u>Tx DOT - Dicker Road Line Relocation</u>		<u>Time/ Hrs.</u>
13-Mar	TX DOT provided Notice to Proceed on this project; Conf call with Mark Gerding regarding need for a Cash Forecast and Timeline to provide to Kindle	1.25
13-Mar	Call with Gener to discuss NTP from TX DOT on this project	0.25
15-Mar	Conf Call with Kindle Team (Gener, Grace, Julie) to discuss status and next steps for this project	0.75
15-Mar	Follow-up call with Mark Gerding (M&H) after Kindle call. Worked with Mark to develop responses to Kindle Team questions regarding mark-up, next steps, contracting process and TX DOT timing	1.5
26-Mar	Call with Mark Gerding prior to update call with Kindle	0.5
26-Mar	Conf call with Kindle and M&H for follow-up on Construction path forward and Contracting process.	0.5
27-Mar	Call with Mark Gerding to discuss breakout of Activities/Contracts for the various construction elements Redrafted and sent to Kindle Team	1.75
<b>Dicker Road Total</b>		<b>6.5</b>
<b>Total WCH Hours</b>		<b>9</b>

372031



M&H Enterprises Inc.  
dba M&H Energy Services  
19450 HWY 249, Suite 600  
Houston, TX 77070  
(281) 664-7222

**INVOICE**

**Bill To: CAMS Midstream**

Colin Harper  
919 Milam Street  
Suite 2300  
Houston, Texas 77002

Invoice Date: 3/7/2019  
Invoice No: INV062127  
Terms:

For services rendered for the calendar month ending **February 28, 2019**

**M&H Project No: 17MH033 Dicker Road Hidalgo County**

Inquiries can be sent to charper@camstex.com

**PROFESSIONAL SERVICES**

	Rate	Qty	Amount
Project Controls Coordinator 3	65.00	2.00	\$ 130.00
		2.00	\$ 130.00

Total Invoice Amount: \$ 130.00 ✓

3055000 104.354-00-00-0000

**RECEIVED**  
MAR 26 2019  
A/P DEPARTMENT

*[Signature]* 3.15.19  
R2: *[Signature]* Pipelin  
Dicker Road  
Relocation

Project Manager: M. Gerding

*[Signature]*

Task ID	Date	User ID	Employee Class	Billing Description	Pay Code	Qty	Bill Rate	Cost Amount	Bill Amount
---------	------	---------	----------------	---------------------	----------	-----	-----------	-------------	-------------

**M&H Project No: 17MH033 Dicker Road Hidalgo County**

**Professional Services**

<b>ENG-PC-2</b>	2/19/2019	linscombek	Project Controls Coordinator 3	Cash flow projections document	HOURLY	1.00	65.00		65.00
	2/22/2019	linscombek	Project Controls Coordinator 3	Cash flow projections document	HOURLY	1.00	65.00		65.00
				<b>Project Coordination - Controls</b>	<b>Task Totals</b>	<b>2.00</b>			<b>\$ 130.00</b>
				<b>Professional Services Total</b>		<b>2.00</b>			<b>\$ 130.00</b>

**Total Invoice Amount:**                     \$ 130.00



**CONSOLIDATED ASSET MANAGEMENT SERVICES, LLC**

919 Milam Street, Suite 2300 Houston, TX 77002-5418

TO: Lonestar Pipeline Company, LLC  
 c/o Frontera Energy Center  
 900 S Goodwin Road  
 Mission, TX 78572

Attention: Gener.Gotiangco

[gener.gotiangco@kindle-energy.com](mailto:gener.gotiangco@kindle-energy.com)

Invoice No.: LONPIP 20190430  
 Date: 13-May-2019  
 Due Date: 28-May-2019  
 Prepared by: R.Wilson  
 713-358-9743

Pursuant to the terms of the Pipeline Services Agreement dated 11/1/2014 by and between Consolidated Asset Management Services, LLC ("CAMS") and Lonestar Pipeline Company, LLC (d/b/a Rio Grande Interstate Pipeline LLC) ("Lonestar"); Non-Routine fees per "Exhibit 1" to the above contract:

**Non-Routine Services:**

**CAMS "Allocated Time for Colin Harper" related to Audits and Dicker Road Relocation**

(see attached time allocation schedule)

Audit Work - April	3.00	
Hours:	3.00	
Rate per Hour:	250.00	750.00

**CAMS "Allocated Time for Colin Harper" related to the Dicker Road Line Relocation**

(see attached time allocation schedule)

Tx Dot Dicker Road Line Relocation - April	1.75	
Hours:	1.75	
Rate per Hour:	250.00	437.50

**437.50** TxDOT Reimbursable

**Other Non-Routine Services:**

CAMS Trident - Locate & Mark Lines ( Inv# 066018 dated 4/30/19)	4,781.14
M&H Enterprises, Inc. - March Engineering Services (Inv# INV062334 dated 4/8/19) plus 15% markup	465.75
M&H Enterprises, Inc. - March Engineering Services (Inv# INV062335 dated 4/4/19) plus 15% markup	<b>775.10</b>
M&H Enterprises, Inc. - March Engineering Services (Inv# INV062629 dated 5/9/19) plus 15% markup	<b>10,114.25</b>
Majic Valley Electric - April electric for rectifiers ( Inv# 290790-APR dated 4/26/19)	83.30
Direct Energy - April electric ( Inv# 191260038285178 dated 5/6/19)	41.39
Direct Energy - April electric ( Inv# 191270038300527 dated 5/7/19)	12.12
Texas Excavation Safety System - April message fees ( Inv# 19-8702 dated 4/30/19)	60.80

**10,114.25** TxDOT Reimbursable

**TOTAL AMOUNT DUE:**

**\$ 17,521.35**

**Wire Instructions:**  
 Consolidated Asset Management  
 Services Texas, LLC  
 Amegy Bank  
 ABA#: 113011258  
 Account # 003771350

CO	Coding:					Amount
CAMSTEX	Acct	Subaccount				
LONPIP	1110000	104	000	00	0000	17,521.35
	1140000	104	000	00	0000	0.00
	3050000	104	354	00	0000	(1,187.50)
	3055000	104	354	00	0000	(16,333.85)

**CAMS Time Allocation**  
**Name: Colin Harper**  
**Month: April 2019**

**TRRC O&M and D&A Audits**

**Time/ Hrs.**

29-Apr	Audit Prep meeting with Simon Pena; AM O&M meeting and afternoon review	1.5
30-Apr	Audit Prep meeting with Simon Pena; AM D&A meeting and afternoon review	1.25
	Call with Oscar Diaz regarding his D&A Program and paperwork	0.25
<b>TRRC Audit Prep Mtgs Total</b>		<b>3</b>

**Tx DOT - Dicker Road Line Relocation**

**Time/ Hrs.**

10-Apr	Call with Mark Gerding at M&H regarding Land (ROW) needed for the project and the status of the RFQ bid packet. E-mailed Kindle Team with an update and a request for how they want to pursue the needed land (ROW) for the construction	1.25
25-Apr	Call with Kindle Team on the status of the Dicker Road Project and action plan	0.25
25-Apr	Call with Joe Polacious at Brighton Group regarding support for needed land (ROW) for Dicker Road	0.25
<b>Dicker Road Total</b>		<b>1.75</b>

COPY

INVOICE



M&H Enterprises Inc.  
dba M&H Energy Services  
19450 HWY 249, Suite 600  
Houston, TX 77070  
(281) 664-7222

Invoice Date: 4/4/2019  
Invoice No: INV062335  
Terms:

Bill To: CAMS Midstream

Colin Harper  
919 Milam Street  
Suite 2300  
Houston, Texas 77002

For services rendered for the calendar month ending **March 31, 2019**

M&H Project No: 17MH033 Dicker Road Hidalgo County

Inquiries can be sent to charper@camstex.com

PROFESSIONAL SERVICES

Project Controls Coordinator 3  
Senior Technical Director

	Rate	Qty	Amount
	65.00	1.00	\$ 65.00
	174.00	3.50	\$ 609.00
		4.50	\$ 674.00

Total Invoice Amount: \$ 674.00

3055000 104-354-00-00-000

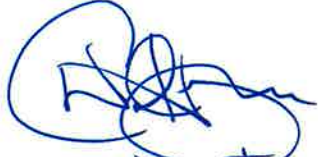
  
4.11.19  
RE: Lanester  
Dicker Road  
Relocation

Project Manager: M. Gerding

Billable - April  
RW

Task ID	Date	User ID	Employee Class	Billing Description	Pay Code	Qty	Bill Rate	Cost Amount	Bill Amount
---------	------	---------	----------------	---------------------	----------	-----	-----------	-------------	-------------

**M&H Project No: 17MH033 Dicker Road Hidalgo County**

**Professional Services**

<b>ENG-PC-2</b>	3/13/2019	linscombek	Project Controls Coordinator 3	Trans 0005, weekly cost report	HOURLY	1.00	65.00		65.00
				<b>Project Coordination - Controls</b>	<b>Task Totals</b>	<b>1.00</b>			<b>\$ 65.00</b>
<b>ENG-PC-3</b>	3/13/2019	gerdingm	Senior Technical Director	cash flow projection spreadsheet to COLin Harper	EXEMPT	1.00	174.00		174.00
	3/15/2019	gerdingm	Senior Technical Director	project logistics; email to Anthiny Garza and followup with Colin Harper regarding steps required over next wo months	EXEMPT	1.00	174.00		174.00
				<b>Project Coordination - General</b>	<b>Task Totals</b>	<b>2.00</b>			<b>\$ 348.00</b>
<b>ENG-PC-5</b>	3/26/2019	gerdingm	Senior Technical Director	phone conference with Kindle	EXEMPT	0.50	174.00		87.00
	3/27/2019	gerdingm	Senior Technical Director	research contractors for bidding, followup to tuesday's phone conference.	EXEMPT	1.00	174.00		174.00
				<b>Project Coordination - Meetings</b>	<b>Task Totals</b>	<b>1.50</b>			<b>\$ 261.00</b>
<b>Professional Services Total</b>						<b>4.50</b>			<b>\$ 674.00</b>

Total Invoice Amount: \$ 674.00



M&H Enterprises Inc.  
 dba M&H Energy Services  
 19450 HWY 249, Suite 600  
 Houston, TX 77070  
 (281) 664-7222

# INVOICE

**Bill To: CAMS Midstream**

Colin Harper  
 919 Milam Street  
 Suite 2300  
 Houston, Texas 77002

Invoice Date: 5/9/2019  
 Invoice No: INV062629  
 Terms:

For services rendered for the calendar month ending **April 30, 2019**

**M&H Project No: 17MH033 Dicker Road Hidalgo County**

Inquiries can be sent to charper@camstex.com

**PROFESSIONAL SERVICES**

	Rate	Qty	Amount
Designer 1	137.00	1.00	\$ 137.00 ✓
Engineering Consultant 3	98.00	5.50	\$ 539.00 ✓
Graduate Eng Consultant	80.00	7.00	\$ 560.00 ✓
Project Controls Coordinator 2	65.00	1.00	\$ 65.00 ✓
Senior Technical Director	174.00	43.00	\$ 7,482.00 ✓
		57.50	\$ 8,783.00

**EXPENSES**

\$ 12.00

Total Invoice Amount: **\$ 8,795.00**

*Handwritten signature and date: 5.13.19*  
 R2: *Constantin Colin*  
 Dicker Road Relocation

Project Manager: M. Gerding

*REIMBURSE*

Task ID	Date	User ID	Employee Class	Billing Description	Pay Code	Qty	Bill Rate	Cost Amount	Bill Amount
---------	------	---------	----------------	---------------------	----------	-----	-----------	-------------	-------------

**M&H Project No: 17MH033 Dicker Road Hidalgo County**

**Professional Services**

<b>ENG-PC-2</b>	4/22/2019	linscombek	Project Controls Coordinator 2	Project controls	HOURLY	1.00	65.00		65.00
				<b>Project Coordination - Controls</b>	<b>Task Totals</b>	<b>1.00</b>			<b>\$ 65.00</b>
<b>ENG-PC-3</b>	4/1/2019	gerdingm	Senior Technical Director	RFQ - General contractor / project schedule / PEP	EXEMPT	3.00	174.00		522.00
	4/2/2019	gerdingm	Senior Technical Director	RFQ - General contractor / project schedule / PEP	EXEMPT	3.00	174.00		522.00
	4/3/2019	gerdingm	Senior Technical Director	RFQ - General contractor	EXEMPT	2.00	174.00		348.00
	4/4/2019	gerdingm	Senior Technical Director	RFQ - General contractor / project schedule / PEP	EXEMPT	3.00	174.00		522.00
	4/5/2019	gerdingm	Senior Technical Director	RFQ - General contractor / project schedule / PEP	EXEMPT	3.00	174.00		522.00
	4/6/2019	gerdingm	Senior Technical Director	RFQ - General contractor	EXEMPT	3.00	174.00		522.00
	4/8/2019	gerdingm	Senior Technical Director	RFQ, contract & appendix	EXEMPT	4.00	174.00		696.00
	4/9/2019	gerdingm	Senior Technical Director	RFQ, contract & appendix	EXEMPT	4.00	174.00		696.00
	4/10/2019	gerdingm	Senior Technical Director		EXEMPT	4.00	174.00		696.00
	4/15/2019	gerdingm	Senior Technical Director	RFQ & exhibits	EXEMPT	3.00	174.00		522.00
	4/17/2019	gerdingm	Senior Technical Director	RFQ & exhibits	EXEMPT	2.00	174.00		348.00
	4/18/2019	gerdingm	Senior Technical Director	RFQ & exhibits	EXEMPT	1.00	174.00		174.00
	4/29/2019	gerdingm	Senior Technical Director	budget review, schedule, contract & RFQ	EXEMPT	4.00	174.00		696.00
	4/30/2019	gerdingm	Senior Technical Director	budget review, schedule, contract & RFQ	EXEMPT	3.00	174.00		522.00
	4/15/2019	messerr	Engineering Consultant 3	Hydrostatic Test Procedure digital conversion	EXEMPT	4.50	98.00		441.00
	4/16/2019	messerr	Engineering Consultant 3	Hydrostatic Test Procedure digital conversion	EXEMPT	1.00	98.00		98.00

Task ID	Date	User ID	Employee Class	Billing Description	Pay Code	Qty	Bill Rate	Cost Amount	Bill Amount
<b>ENG-PC-3</b>	4/16/2019	ramirezg	Graduate Eng Consultant	Hydrotest Forms ✓	EXEMPT	7.00	80.00		560.00
				<b>Project Coordination - General</b>	<b>Task Totals</b>	<b>54.50</b>		<b>\$ 8,407.00</b>	
<b>ENG-PC-5</b>	4/25/2019	gerdingm	Senior Technical Director	conference call with CAMS & Kindle	EXEMPT	1.00	174.00		174.00
				<b>Project Coordination - Meetings</b>	<b>Task Totals</b>	<b>1.00</b>		<b>\$ 174.00</b>	
<b>PL-RC-D</b>	4/10/2019	smithj	Designer 1	Drawings for RFQ Support ✓	HOURLY	1.00	137.00		137.00
				<b>Road Crossing Exhibits - AutoCAD Drawing</b>	<b>Task Totals</b>	<b>1.00</b>		<b>\$ 137.00</b>	
<b>Professional Services Total</b>						<b>57.50</b>			<b>\$ 8,783.00</b>

**Expenses**

<b>EXP - SOFTWARE</b>	4/13/2019	Software	Software Charges	Software charge - CAD ✓	EXP	1.00	12.000	12.00	12.00
				<b>Software - 12 CAD / 25 SACS</b>	<b>Task Totals</b>	<b>1.00</b>		<b>12.00</b>	<b>\$ 12.00</b>
<b>Expenses Total</b>						<b>1.00</b>			<b>\$ 12.00</b>

Total Invoice Amount: \$ 8,795.00



**CONSOLIDATED ASSET MANAGEMENT SERVICES, LLC**

919 Milam Street, Suite 2300 Houston, TX 77002-5418

TO: Lonestar Pipeline Company, LLC  
 c/o Frontera Energy Center  
 900 S Goodwin Road  
 Mission, TX 78572

Attention: Ed Fuselier

[ed.fuselier@kindle-energy.com](mailto:ed.fuselier@kindle-energy.com)

Invoice No.: LONPIP 20190531  
 Date: 12-Jun-2019  
 Due Date: 27-Jun-2019  
 Prepared by: R.Wilson  
 713-358-9743

Pursuant to the terms of the Pipeline Services Agreement dated 11/1/2014 by and between Consolidated Asset Management Services, LLC ("CAMS") and Lonestar Pipeline Company, LLC (d/b/a Rio Grande Interstate Pipeline LLC) ("Lonestar"); Non-Routine fees per "Exhibit 1" to the above contract:

**Non-Routine Services:**

**CAMS "Allocated Time for Colin Harper" related to Audits**

(see attached time allocation schedule)

TRRC O&M and D&A Audits	9.50	
TRRC IMP Audit	7.00	
	16.50	
Hours:	16.50	
Rate per Hour:	250.00	4,125.00

★ CAMS "Allocated Time for Colin Harper" related to the Dicker Road Line Relocation

(see attached time allocation schedule)

TX DOT Dicker Road Line Relocation - Reimbursable by TX DOT	25.75	
	25.75	
Hours:	25.75	
Rate per Hour:	250.00	6,437.50

TxDOT  
Reimbursable

**Other Non-Routine Services:**

CAMS Trident - Locate & Mark Lines ( Inv# 066585 dated 5/31/19)	7,488.31
Colin Harper - Meal Expense for TRRC Audit Prep - Expense Report dated 6/03/19	101.54
SRP & Associates - Consulting & Expenses for TRCC Audit ( Inv# P-2 dated 5/15/19)	19,972.05
Majic Valley Electric - May electric for rectifiers ( Inv# 290790-MAY dated 5/28/19)	84.66
Direct Energy - May electric ( Inv# 191550038576852 dated 6/4/19)	41.66
Texas Excavation Safety System - May message fees ( Inv# 19-8702 dated 4/30/19)	60.80

TOTAL AMOUNT DUE:

\$ 38,311.52

**Wire Instructions:**  
 Consolidated Asset Management  
 Services Texas, LLC  
 Amegy Bank  
 ABA#: 113011258  
 Account # 003771350

CO	Coding:						Amount
CAMSTEX	Acct		Subaccount				
LONPIP	1110000	104	000	00	00	0000	38,311.52
	1140000	104	000	00	00	0000	0.00
	3050000	104	354	00	00	0000	(10,562.50)
	3055000	104	354	00	00	0000	(27,749.02)

**CAMS Time Allocation**

Name: Colin Harper

Month: May 2019

**Lonestar Pipeline O&M****TRRC O&M and D&A Audits****Time/ Hrs.**

1-May	O&M Manual Revisions and Updates for TRRC O&M Audit; review with Simon Pena	3.50
2-May	O&M Audit Prep with Simon P.	1.25
3-May	Final Review of Manual and Procedures for the O&M Audit	2.50
6-May	TRRC Audit commenced - Kick-off mtg with Auditor and Simon P.	1.25
9-May	TRRC wrap-up mtg with Auditor and Simon P. - clean D&A and O&M audit. No NOVs or issues.	<u>1.00</u>
		<b>9.50</b>

**TRRC IMP Audit****Time/ Hrs.**

8-May	Updated Lonestar IMP Manual in advance of TRRC Audit prep meetings	2.50
9-May	Updated Lonestar IMP Manual in advance of TRRC Audit prep meetings	1.50
20-May	TRRC IMP Audit prep with Simon P.	1.50
21-May	TRRC IMP Audit prep with Simon P.	<u>1.50</u>
		<b>7.00</b>
	<b>TRRC Audit Prep Mtgs and Audit - Total</b>	<b>7.00</b>

**TX DOT - Dicker Road Line Relocation - (Reimbursable)****Time/ Hrs.**

3-May	Contacted Jose Caso with Broughton Group regarding possible land support for Dicker Rd.	0.50
6-May	Conf Call with Grace K. (Kindle) regarding use of Brighton Group - obtained OK	0.25
7-May	Drafted Professional Services Agreement for Brighton Group	1.00
8-May	Turn and execute PSA with Brighton Group	0.50
13-May	Review initial drafts of RFQ docs; Conf Call with Kindle Team to discuss drafts	5.25
14-May	Bid Letter and Construction Agreement; review and redline changes	4.25
15-May	Clean up Construction Agreement with all edits from all parties	3.00
16-May	Call with Brighton Group and M&H re: Land requirements; Work on Procedures for RFQ; e-mail Kindle	1.50
16-May	Draft Task Order for Brighton Group	1.00
17-May	E-mail Update to Kindle and M&H on project status	1.25
20-May	Weekly status call with Kindle and M&H; e-mail to Grace per her request	1.25
23-May	Finalize Welding Procedures with M&H for Dicker Rd.	1.00
24-May	Turn of Welding Procedures with Kindle; aggregate docs for RFQ Bid Packet	1.75
24-May	Call with Brighton Group re: land status	0.25
24-May	E-mail Update to Kindle and M&H on project status	0.50
28-May	Weekly Project Update Call with Kindle and M&H	0.25
28-May	Finalize Dicker Rd Construction Contract Appendices and RFQ Packet	<u>2.25</u>

**Dicker Road Total** **25.75****WCH Total May 2019** **42.25**



**CONSOLIDATED ASSET MANAGEMENT SERVICES, LLC**

919 Milam Street, Suite 2300 Houston, TX 77002-5418

TO: Lonestar Pipeline Company, LLC  
 c/o Frontera Energy Center  
 900 S Goodwin Road  
 Mission, TX 78572

Attention: Ed Fuselier  
[ed.fuselier@kindle-energy.com](mailto:ed.fuselier@kindle-energy.com)

Invoice No.: LONPIP 20190630  
 Date: 15-Jul-2019  
 Due Date: 30-Jul-2019  
 Prepared by: R.Wilson 713-358-9743

Pursuant to the terms of the Pipeline Services Agreement dated 11/1/2014 by and between Consolidated Asset Management Services, LLC ("CAMS") and Lonestar Pipeline Company, LLC (d/b/a Rio Grande Interstate Pipeline LLC) ("Lonestar"); Non-Routine fees per "Exhibit 1" to the above contract:

**Non-Routine Services:**

CAMS "Allocated Time for Colin Harper" related to the Dicker Road Line Relocation

(see attached time allocation schedule)

TX DOT Dicker Road Line Relocation - June

Hours: 0.50  
 Rate per Hour: 250.00

**125.00** TxDOT Reimbursable

**Other Non-Routine Services:**

CAMS Trident - Locate & Mark Lines ( Inv# 067088 dated 6/30/19)	3,005.08
Colin Harper - Meal Expense for TRRC Audit Prep - Expense Report dated 7/01/19	22.03
SRP & Associates - Consulting & Expenses for TRCC Audit ( Inv# P-4 dated 6/17/19)	6,482.45
M&H Enterprises, Inc. - May Engineering Services (Inv# INV062920 dated 6/10/19) plus 15% markup	<b>8,199.50</b>
M&H Enterprises, Inc. - June Engineering Services (Inv# INV063203 dated 7/9/19) plus 15% markup	<b>5,001.93</b>
Majic Valley Electric - May electric for rectifiers ( Inv# 290790-JUN dated 6/26/19)	78.82
Direct Energy - June electric ( Inv# 191890038937753 dated 7/8/19)	42.31
Direct Energy - May electric ( Inv# 191620038656208 dated 6/11/19)	12.12
Direct Energy - June electric ( Inv# 191900038956774 dated 7/9/19)	12.12
Texas Excavation Safety System - May message fees ( Inv# 19-10268 dated 5/31/19)	91.20

TxDOT Reimbursable

TOTAL AMOUNT DUE:

**\$ 23,072.56**

**Wire Instructions:**  
 Consolidated Asset Management  
 Services Texas, LLC  
 Amegy Bank  
 ABA#: 113011258  
 Account # 003771350

CO	Coding:						Amount
CAMSTEX	Acct		Subaccount				
LONPIP	1110000	104	000	00	00	0000	23,072.56
	1140000	104	000	00	00	0000	0.00
	3050000	104	354	00	00	0000	(125.00)
	3055000	104	354	00	00	0000	(22,947.56)

**CAMS Time Allocation**

**Name: Colin Harper**

**Month: June 2019**

**Lonestar Pipeline O&M**

**TX DOT - Dicker Road Line Relocation - (Reimbursable)**

**Time/ Hrs.**

7-Jun Dicker Rd Update Call

0.50

**Dicker Road Total**

**0.50**

**WCH Total June 2019**

378-784



M&H Enterprises Inc.  
dba M&H Energy Services  
19450 HWY 249, Suite 600  
Houston, TX 77070  
(281) 664-7222

# INVOICE

**Bill To: CAMS Midstream**

Colin Harper  
919 Milam Street  
Suite 2300  
Houston, Texas 77002

Invoice Date: 6/10/2019  
Invoice No: INV062920  
Terms:

For services rendered for the calendar month ending **May 31, 2019**

**M&H Project No: 17MH033 Dicker Road Hidalgo County**

Inquiries can be sent to [charper@camstex.com](mailto:charper@camstex.com)

**PROFESSIONAL SERVICES**

	Rate	Qty	Amount
Designer 1	137.00	0.50	\$ 68.50
Project Controls Coordinator 2	65.00	17.50	\$ 1,137.50
Project Controls Manager	115.00	6.50	\$ 747.50
Senior Lead Eng Consultant	135.00	3.50	\$ 472.50
Senior Technical Director	174.00	27.00	\$ 4,698.00
		55.00	\$ 7,124.00

**EXPENSES**

\$ 6.00

**RECEIVED**

Total Invoice Amount: **\$ 7,130.00** ✓

JUN 18 2019

A/P DEPARTMENT

3055000 104-354-72-00-000

*[Signature]* 6.13.19  
RE: Low Star Pipeline  
Dicker Road Relocation

*[Signature]*

Project Manager: M. Gerding

— REIMBURSABLE —

Task ID	Date	User ID	Employee Class	Billing Description	Pay Code	Qty	Bill Rate	Cost Amount	Bill Amount
---------	------	---------	----------------	---------------------	----------	-----	-----------	-------------	-------------

**M&H Project No: 17MH033 Dicker Road Hidalgo County**

**Professional Services**

ENG-PC-1	5/21/2019	arnesonp	Senior Lead Eng Consultant	Review RFQ	EXEMPT	0.50	135.00		67.50
	5/22/2019	arnesonp	Senior Lead Eng Consultant	Welding procedure review	EXEMPT	1.00	135.00		135.00
<b>Project Coordination - Management Task Totals</b>						<b>1.50</b>			<b>\$ 202.50</b>
ENG-PC-2	5/21/2019	kregelec	Project Controls Manager	Procedure update and edits	EXEMPT	6.50	115.00		747.50
	5/1/2019	linscombek	Project Controls Coordinator 2	Cost and budget review	HOURLY	2.00	65.00		130.00
	5/7/2019	linscombek	Project Controls Coordinator 2	Project controls	HOURLY	1.00	65.00		65.00
	5/13/2019	linscombek	Project Controls Coordinator 2	Scan and upload Executed DUL, Project controls	HOURLY	1.50	65.00		97.50
	5/14/2019	linscombek	Project Controls Coordinator 2	Native files management	HOURLY	1.00	65.00		65.00
	5/21/2019	linscombek	Project Controls Coordinator 2	PAR, Cost Report	HOURLY	2.00	65.00		130.00
	5/22/2019	linscombek	Project Controls Coordinator 2	Trans 0006 - Welding Procedures	HOURLY	1.00	65.00		65.00
	5/29/2019	linscombek	Project Controls Coordinator 2	RFQ packages	HOURLY	4.00	65.00		260.00
	5/30/2019	linscombek	Project Controls Coordinator 2	RFQ, document controls	HOURLY	5.00	65.00		325.00
<b>Project Coordination - Controls Task Totals</b>						<b>24.00</b>			<b>\$ 1,885.00</b>
ENG-PC-3	5/28/2019	arnesonp	Senior Lead Eng Consultant	RFQ review	EXEMPT	1.00	135.00		135.00
	5/30/2019	arnesonp	Senior Lead Eng Consultant	Final RFQ review	EXEMPT	1.00	135.00		135.00
	5/1/2019	gerdingm	Senior Technical Director	contract	EXEMPT	4.00	174.00		696.00
	5/8/2019	gerdingm	Senior Technical Director	contract & project plan for RFQ	EXEMPT	2.00	174.00		348.00
	5/9/2019	gerdingm	Senior Technical Director	contract & project plan for RFQ	EXEMPT	1.00	174.00		174.00
	5/10/2019	gerdingm	Senior Technical Director	contract & project plan for RFQ	EXEMPT	1.00	174.00		174.00

Task ID	Date	User ID	Employee Class	Billing Description	Pay Code	Qty	Bill Rate	Cost Amount	Bill Amount
ENG-PC-3	5/13/2019	gerdingm	Senior Technical Director	RFQ package	EXEMPT	3.00	174.00		522.00
	5/17/2019	gerdingm	Senior Technical Director	revise coating sectionof the construction manual	EXEMPT	5.00	174.00		870.00
	5/23/2019	gerdingm	Senior Technical Director	welding procedure	EXEMPT	2.00	174.00		348.00
	5/24/2019	gerdingm	Senior Technical Director	RFQ	EXEMPT	2.00	174.00		348.00
	5/28/2019	gerdingm	Senior Technical Director	update RFQ & mtg	EXEMPT	5.00	174.00		870.00
<b>Project Coordination - General</b>					<b>Task Totals</b>	<b>27.00</b>			<b>\$ 4,620.00</b>
ENG-PC-5	5/13/2019	gerdingm	Senior Technical Director	conference call	EXEMPT	1.00	174.00		174.00
	5/16/2019	gerdingm	Senior Technical Director	conference call	EXEMPT	1.00	174.00		174.00
	<b>Project Coordination - Meetings</b>					<b>Task Totals</b>	<b>2.00</b>		
PL-SC-D	5/13/2019	smithj	Designer 1	Pipeline HDD and Location Maps	HOURLY	0.50	137.00		68.50
				<b>Pipeline Schematic - AutoCAD Drawing</b>	<b>Task Totals</b>	<b>0.50</b>			<b>\$ 68.50</b>
<b>Professional Services Total</b>						<b>55.00</b>			<b>\$ 7,124.00</b>

**Expenses**

EXP - SOFTWARE	5/18/2019	Software	Software Charges	Software charge - CAD	EXP	0.50	12.000	6.00	6.00
				<b>Software - 12 CAD / 25 SACS</b>	<b>Task Totals</b>	<b>0.50</b>		<b>6.00</b>	<b>\$ 6.00</b>
<b>Expenses Total</b>						<b>0.50</b>			<b>\$ 6.00</b>

Total Invoice Amount: \$ 7,130.00



M&H Enterprises Inc.  
 dba M&H Energy Services  
 19450 HWY 249, Suite 600  
 Houston, TX 77070  
 (281) 664-7222

# INVOICE

**Bill To: CAMS Midstream**

Colin Harper  
 919 Milam Street  
 Suite 2300  
 Houston, Texas 77002

Invoice Date: 7/9/2019  
 Invoice No: INV063203  
 Terms:

For services rendered for the calendar month ending **June 30, 2019**

**M&H Project No: 17MH033 Dicker Road Hidalgo County**

Inquiries can be sent to charper@camstex.com

**PROFESSIONAL SERVICES**

	Rate	Qty	Amount
Project Controls Coordinator 2	87.00	2.50	\$ 217.50
Purchasing Manager	142.00	1.50	\$ 213.00
Senior Technical Director	185.00	20.00	\$ 3,700.00
Specialist Engineering Consult	146.00	1.50	\$ 219.00
		25.50	\$ 4,349.50

Total Invoice Amount: **\$ 4,349.50**

*[Signature]* 7.12.19  
 RE: Lenesta Pizli  
 Dicker Road Relocation

Project Manager: M. Gerding

Task ID	Date	User ID	Employee Class	Billing Description	Pay Code	Qty	Bill Rate	Cost Amount	Bill Amount
---------	------	---------	----------------	---------------------	----------	-----	-----------	-------------	-------------

**M&H Project No: 17MH033 Dicker Road Hidalgo County**

**Professional Services**

<b>ENG-PC-1</b>	6/24/2019	arnesonp	Specialist Engineering Consult	Brighton coordination and review	EXEMPT	0.50	146.00		73.00
<b>Project Coordination - Management Task Totals</b>						<b>0.50</b>			<b>\$ 73.00</b>
<b>ENG-PC-2</b>	6/3/2019	linscombek	Project Controls Coordinator 2	Project controls	HOURLY	1.00	87.00		87.00
	6/17/2019	linscombek	Project Controls Coordinator 2	RFQ rescheduling	HOURLY	1.50	87.00		130.50
<b>Project Coordination - Controls Task Totals</b>						<b>2.50</b>			<b>\$ 217.50</b>
<b>ENG-PC-3</b>	6/3/2019	arnesonp	Specialist Engineering Consult	Coordination on RFQ	EXEMPT	1.00	146.00		146.00
	6/17/2019	gerdingm	Senior Technical Director	TC's with Colin Harper, Strike, Jose Caso, Grace; general project coordination	EXEMPT	4.00	185.00		740.00
	6/18/2019	gerdingm	Senior Technical Director	followup with Driver regarding RFQ and walk down; email to project team with schedule update	EXEMPT	3.00	185.00		555.00
	6/19/2019	gerdingm	Senior Technical Director	prep for contractor walk down	EXEMPT	4.00	185.00		740.00
	6/20/2019	gerdingm	Senior Technical Director	Follow up discussion with Jose Caso regarding ROW negotiations	EXEMPT	2.00	185.00		370.00
	6/21/2019	gerdingm	Senior Technical Director	discussion with Anthony Garza regarding project schedule; email response to Colin Harper	EXEMPT	1.00	185.00		185.00
	6/24/2019	gerdingm	Senior Technical Director	BOM prep & small contractor review	EXEMPT	3.00	185.00		555.00
	6/25/2019	gerdingm	Senior Technical Director	chase down various small contractors; ndt, survey,	EXEMPT	3.00	185.00		555.00
	6/3/2019	smiths	Purchasing Manager	Review of RFQ data	EXEMPT	1.50	142.00		213.00
<b>Project Coordination - General Task Totals</b>						<b>22.50</b>			<b>\$ 4,059.00</b>
<b>Professional Services Total</b>						<b>25.50</b>			<b>\$ 4,349.50</b>

Task ID	Date	User ID	Employee Class	Billing Description	Pay Code	Qty	Bill Rate	Cost Amount	Bill Amount
---------	------	---------	----------------	---------------------	----------	-----	-----------	-------------	-------------

Total Invoice Amount: \$ 4,349.50



**CONSOLIDATED ASSET MANAGEMENT SERVICES, LLC**

919 Milam Street, Suite 2300 Houston, TX 77002-5418

TO: Lonestar Pipeline Company, LLC  
 c/o Frontera Energy Center  
 900 S Goodwin Road  
 Mission, TX 78572

Attention: Ed Fuselier  
[ed.fuselier@kindle-energy.com](mailto:ed.fuselier@kindle-energy.com)

Invoice No.: LONPIP 20190731  
 Date: 8-Aug-2019  
 Due Date: 23-Aug-2019  
 Prepared by: R.Wilson 713-358-9743

Pursuant to the terms of the Pipeline Services Agreement dated 11/1/2014 by and between Consolidated Asset Management Services, LLC ("CAMS") and Lonestar Pipeline Company, LLC (d/b/a Rio Grande Interstate Pipeline LLC) ("Lonestar"); Non-Routine fees per "Exhibit 1" to the above contract:

**Non-Routine Services:**

CAMS "Allocated Time for Colin Harper" related to the Dicker Road Line Relocation

(see attached time allocation schedule)

TX DOT Dicker Road Line Relocation - Reimbursable by TX DOT	2.50
Hours:	2.50
Rate per Hour:	250.00

TxDOT  
 Reimbursable  
**625.00**

**Other Non-Routine Services:**

CAMS Trident - Locate & Mark Lines ( Inv# 067595 dated 7/31/19)	3,276.32
Majic Valley Electric - July electric for rectifiers ( Inv# 290790-JUL dated 7/24/19)	70.52
Direct Energy - July electric ( Inv# 192180039240714 dated 8/5/19)	41.25
Direct Energy - July electric ( Inv# 192180039246575 dated 8/5/19)	12.12
Texas Excavation Safety System - June message fees ( Inv# 19-12482 dated 6/30/19)	64.60

**TOTAL AMOUNT DUE: \$ 4,089.81**

**Wire Instructions:**  
 Consolidated Asset Management  
 Services Texas, LLC  
 Amegy Bank  
 ABA#: 113011258  
 Account # 003771350

CO	Coding:						Amount
CAMSTEX	Acct		Subaccount				
LONPIP	1110000	104	000	00	00	0000	4,089.81
	1140000	104	000	00	00	0000	0.00
	3050000	104	354	00	00	0000	(625.00)
	3055000	104	354	00	00	0000	(3,464.81)

**CAMS Time Allocation**

**Name: Colin Harper**

**Month: July 2019**

**Lonestar Pipeline O&M**

<u>TX DOT - Dicker Road Line Relocation - (Reimbursable)</u>		<u>Time/ Hrs.</u>
2-Jul	Dicker Rd - Weekly Project Update Call w/ Kindle and M&H	0.50
8-Jul	Dicker Road call with M&H regarding Brighton Group update and status on land/workspace	0.25
9-Jul	Dicker Rd - Prep and Weekly Project Update Call w/ Kindle and M&H; Land, Bid Walk; Schedule; and Cash Flow Projection	0.50
16-Jul	Dicker Rd - Weekly Project Update Call w/ Kindle and M&H	0.25
23-Jul	Dicker Rd - Weekly Project Update Call w/ Kindle and M&H	0.25
30-Jul	Dicker Rd - Prep and Weekly Project Update Call w/ Kindle and M&H; Bid Results; Project Task List	0.75

**Dicker Road Total**

**2.50**

**WCH Total July 2019**

**2.50**



**CONSOLIDATED ASSET MANAGEMENT SERVICES, LLC**

919 Milam Street, Suite 2300 Houston, TX 77002-5418

TO: Lonestar Pipeline Company, LLC  
 c/o Frontera Energy Center  
 900 S Goodwin Road  
 Mission, TX 78572

Attention: Ed Fuselier

[ed.fuselier@kindle-energy.com](mailto:ed.fuselier@kindle-energy.com)

Invoice No.: LONPIP 20190831  
 Date: 16-Sep-2019  
 Due Date: 1-Oct-2019  
 R.Wilson  
 Prepared by: 713-358-9743

Pursuant to the terms of the Pipeline Services Agreement dated 11/1/2014 by and between Consolidated Asset Management Services, LLC ("CAMS") and Lonestar Pipeline Company, LLC (d/b/a Rio Grande Interstate Pipeline LLC) ("Lonestar"); Non-Routine fees per "Exhibit 1" to the above contract:

**Other Non-Routine Services:**

CAMS Trident - Locate & Mark Lines ( Inv# 068045 dated 8/31/19)	674.06
CAMS Trident - Vault Cleanout & Test Station Repair ( Inv# 068041 dated 8/31/19)	13,752.00
M&H Enterprises, Inc. - July Engineering Services (Inv# INV063509 dated 8/7/19) plus 15% markup	27,717.70
M&H Enterprises, Inc. - July Engineering Services (Inv# INV063512 dated 8/7/19) plus 15% markup	1,574.35
M&H Enterprises, Inc. - July Engineering Services (Inv# INV063510 dated 8/7/19) plus 15% markup	7,410.43
Majic Valley Electric - July electric for rectifiers ( Inv# 290790-JUL dated 7/24/19)	76.02
Direct Energy - Aug electric ( Inv# 192470039538001 dated 9/4/19)	40.40
Direct Energy - Aug electric ( Inv# 192490039565390 dated 9/6/19)	12.12
Texas Excavation Safety System - Aug message fees ( Inv# 19-15756 dated 8/31/19)	81.70

TxDOT  
Reimbursable

**TOTAL AMOUNT DUE:**

**\$ 51,338.78**

**Wire Instructions:**  
 Consolidated Asset Management  
 Services Texas, LLC  
 Amegy Bank  
 ABA#: 113011258  
 Account # 003771350

CO	Coding:						Amount
CAMSTEX	Acct		Subaccount				
LONPIP	1110000	104	000	00	00	0000	51,338.78
	1140000	104	000	00	00	0000	0.00
	3050000	104	354	00	00	0000	0.00
	3055000	104	354	00	00	0000	(51,338.78)

384335



M&H Enterprises Inc.  
dba M&H Energy Services  
19450 HWY 249, Suite 600  
Houston, TX 77070  
(281) 664-7222

# INVOICE

**Bill To: CAMS Midstream**

Colin Harper  
919 Milam Street  
Suite 2300  
Houston, Texas 77002

Invoice Date: 8/7/2019  
Invoice No: INV063509  
Terms:

For services rendered for the calendar month ending **July 31, 2019**

**M&H Project No: 17MH033 Dicker Road Hidalgo County**

Inquiries can be sent to charper@camstex.com

**PROFESSIONAL SERVICES**

Design Supervisor
Engineering Consultant 4
Project Controls Coordinator 2
Purchasing Agent 2
Purchasing Manager
Senior Project Director
Specialist Engineering Consult
Sr Specialist Eng Consultant

	Rate	Qty	Amount
	176.00	3.00	\$ 528.00
	101.00	22.50	\$ 2,272.50
	101.00	7.00	\$ 707.00
	116.00	7.50	\$ 870.00
	165.00	6.00	\$ 990.00
	200.00	5.00	\$ 1,000.00
	169.00	2.00	\$ 338.00
	185.00	83.00	\$ 15,355.00
		136.00	\$ 22,060.50 ✓

**EXPENSES**

\$ 2,041.85 ✓

Total Invoice Amount: **\$ 24,102.35** ✓

3055000 104,354,72-00-000

**RECEIVED**

AUG 27 2019

A/P DEPARTMENT

Project Manager: R. Perego

*[Signature]* 8.08.19  
RE: Lenesta Pipeline  
Dicker Road Relocation

- REIMBURSABLE - TX DOT

Task ID	Date	User ID	Employee Class	Billing Description	Pay Code	Qty	Bill Rate	Cost Amount	Bill Amount
---------	------	---------	----------------	---------------------	----------	-----	-----------	-------------	-------------

**M&H Project No: 17MH033 Dicker Road Hidalgo County**

**Professional Services**

ENG-PC-1	7/1/2019	arnesonp	Specialist Engineering Consult	Dicker road support	EXEMPT	1.00	169.00		169.00
	7/9/2019	arnesonp	Specialist Engineering Consult	Dicker road support and coordination	EXEMPT	1.00	169.00		169.00
	7/17/2019	peregorg	Senior Project Director	Project background, drawing reviews	EXEMPT	2.00	200.00		400.00
	7/23/2019	peregorg	Senior Project Director	Weekly conference call, bidder clarifications	EXEMPT	1.00	200.00		200.00
	7/25/2019	peregorg	Senior Project Director	Project tracker, subcontractor T&Cs	EXEMPT	2.00	200.00		400.00
<b>Project Coordination - Management</b>						<b>Task Totals</b>	<b>7.00</b>		<b>\$ 1,338.00</b>
ENG-PC-2	7/8/2019	linscombek	Project Controls Coordinator 2	RFQ - Added 3 bidders	HOURLY	2.00	101.00		202.00
	7/9/2019	linscombek	Project Controls Coordinator 2	RFQ activities	HOURLY	3.00	101.00		303.00
	7/10/2019	linscombek	Project Controls Coordinator 2	Project coordination	HOURLY	0.50	101.00		50.50
	7/22/2019	linscombek	Project Controls Coordinator 2	Bid walk clarification notes	HOURLY	1.00	101.00		101.00
	7/23/2019	linscombek	Project Controls Coordinator 2	Project Controls	HOURLY	0.50	101.00		50.50
<b>Project Coordination - Controls</b>						<b>Task Totals</b>	<b>7.00</b>		<b>\$ 707.00</b>
ENG-PC-3	7/1/2019	gerdingm	Sr Specialist Eng Consultant	follow up with ROW status; search for replacement contractors for two that no-bid	EXEMPT	4.00	185.00		740.00
	7/2/2019	gerdingm	Sr Specialist Eng Consultant	sub-contractor analysis, geotechnical, materials, NDT, water hauler; contact & request rate sheets, create spread sheet analysis	EXEMPT	7.00	185.00		1,295.00
	7/3/2019	gerdingm	Sr Specialist Eng Consultant	prep for onsite job showing; confirm sub contractor bidding is good for TxDOT	EXEMPT	6.00	185.00		1,110.00
	7/5/2019	gerdingm	Sr Specialist Eng Consultant	sub contractor list	EXEMPT	3.00	185.00		555.00
	7/12/2019	gerdingm	Sr Specialist Eng Consultant	follow up report of field trip	EXEMPT	3.50	185.00		647.50

Task ID	Date	User ID	Employee Class	Billing Description	Pay Code	Qty	Bill Rate	Cost Amount	Bill Amount
ENG-PC-3	7/16/2019	gerdingm	Sr Specialist Eng Consultant	weekly project review	EXEMPT	2.00	185.00		370.00
	7/22/2019	gerdingm	Sr Specialist Eng Consultant	bid clarifications	EXEMPT	4.00	185.00		740.00
	7/23/2019	gerdingm	Sr Specialist Eng Consultant	bid claaarifications	EXEMPT	3.00	185.00		555.00
	7/24/2019	gerdingm	Sr Specialist Eng Consultant	update project tracker	EXEMPT	5.50	185.00		1,017.50
	7/25/2019	gerdingm	Sr Specialist Eng Consultant	service agreement; nitrogen contractor	EXEMPT	6.50	185.00		1,202.50
	7/26/2019	gerdingm	Sr Specialist Eng Consultant	nitrogen contrcator; OMNI	EXEMPT	2.50	185.00		462.50
	7/29/2019	gerdingm	Sr Specialist Eng Consultant	update Nitrogen subcontractor; bid reviews	EXEMPT	6.00	185.00		1,110.00
	7/8/2019	kleinerm	Purchasing Agent 2	Clarifications / bidders.	HOURLY	1.00	116.00		116.00
	7/9/2019	kleinerm	Purchasing Agent 2	Bid list.	HOURLY	1.50	116.00		174.00
	7/25/2019	kleinerm	Purchasing Agent 2	Clarifications.	HOURLY	1.00	116.00		116.00
	7/29/2019	kleinerm	Purchasing Agent 2	Bid Opening / CBE	HOURLY	2.00	116.00		232.00
	7/30/2019	kleinerm	Purchasing Agent 2	Bids / CBE	HOURLY	1.00	116.00		116.00
	7/31/2019	kleinerm	Purchasing Agent 2	Clarifications	HOURLY	1.00	116.00		116.00
	7/17/2019	ramirezg	Engineering Consultant 4	Bill of Materials Development	EXEMPT	3.00	101.00		303.00
	7/18/2019	ramirezg	Engineering Consultant 4	Bill of Materials Development	EXEMPT	5.00	101.00		505.00
7/8/2019	smiths	Purchasing Manager	Update bid lists, select additional bidders	EXEMPT	1.50	165.00		247.50	
7/22/2019	smiths	Purchasing Manager		EXEMPT	2.00	165.00		330.00	
7/23/2019	smiths	Purchasing Manager	Bidder clarifications and updated HDD tie in drawings	EXEMPT	1.00	165.00		165.00	
7/25/2019	smiths	Purchasing Manager	Prepare and submit materials BOM for quotes	EXEMPT	1.00	165.00		165.00	
<b>Project Coordination - General</b>						<b>Task Totals</b>	<b>74.00</b>		<b>\$ 12,390.50</b>
ENG-PC-4	7/8/2019	gerdingm	Sr Specialist Eng Consultant	prep for bid showing	EXEMPT	7.50	185.00		1,387.50
	7/9/2019	gerdingm	Sr Specialist Eng Consultant	prep for bid showing at 10th and Dicker	EXEMPT	4.00	185.00		740.00

Task ID	Date	User ID	Employee Class	Billing Description	Pay Code	Qty	Bill Rate	Cost Amount	Bill Amount
<b>ENG-PC-4</b>	7/10/2019	gerdingm	Sr Specialist Eng Consultant	Travel from Houston to McAllen for job showing with contractors	EXEMPT	4.00	185.00		740.00
	7/11/2019	gerdingm	Sr Specialist Eng Consultant	prep for onSite visit at job site, 10th and Dicker; job showing with bidders; travel for return to Houston	EXEMPT	10.00	185.00		1,850.00
	7/10/2019	ramirezg	Engineering Consultant 4	Travel Time	EXEMPT	5.00	101.00		505.00
	7/11/2019	ramirezg	Engineering Consultant 4	Site Visit	EXEMPT	9.00	101.00		909.00
<b>Project Coordination - Site Visit</b>					<b>Task Totals</b>	<b>39.50</b>			<b>\$ 6,131.50</b>
<b>ENG-PC-5</b>	7/2/2019	gerdingm	Sr Specialist Eng Consultant	conference call with CAMS and Kindle	EXEMPT	1.00	185.00		185.00
	7/23/2019	gerdingm	Sr Specialist Eng Consultant	weekly project update with CAMS & Kindle	EXEMPT	1.00	185.00		185.00
	7/29/2019	gerdingm	Sr Specialist Eng Consultant	Bid Opening	EXEMPT	0.50	185.00		92.50
	7/30/2019	gerdingm	Sr Specialist Eng Consultant	prep for mtg & meeting;followup with OMNI regarding their estimate	EXEMPT	2.00	185.00		370.00
	7/16/2019	ramirezg	Engineering Consultant 4	Update Meeting	EXEMPT	0.50	101.00		50.50
	7/29/2019	smiths	Purchasing Manager	Sealed bid opening and review	EXEMPT	0.50	165.00		82.50
<b>Project Coordination - Meetings</b>					<b>Task Totals</b>	<b>5.50</b>			<b>\$ 965.50</b>
<b>PL-PC-D</b>	7/18/2019	smithj	Design Supervisor	HDD Tie-In Spool Details	HOURLY	2.00	176.00		352.00
	7/19/2019	smithj	Design Supervisor	HDD Tie-In Spool Details	HOURLY	1.00	176.00		176.00
<b>Pipeline Connection Details - AutoCAD Drawing</b>					<b>Task Totals</b>	<b>✓ 3.00</b>			<b>\$ 528.00</b>
<b>Professional Services Total</b>						<b>136.00</b>			<b>\$ 22,060.50</b>

**Expenses**

<b>EXP - MARK UP</b>	7/10/2019	gerdingm	Sr Specialist Eng Consultant	MC 07-10-2019 United Airlines - AirFare/Roundtrip	EXP	1.00	647.460	588.60 ✓	647.46
	7/31/2019	gerdingm	Sr Specialist Eng Consultant	MC 07-11-19 New South Parking - Parking	EXP	1.00	37.400	34.00 ✓	37.40
	7/31/2019	gerdingm	Sr Specialist Eng Consultant	MC 07-11-19 Holiday Inn Exporeess - Hotel room for M Gerding	EXP	1.00	173.380	157.62 ✓	173.38

Task ID	Date	User ID	Employee Class	Billing Description	Pay Code	Qty	Bill Rate	Cost Amount	Bill Amount
EXP - MARK UP	7/31/2019	gerdingm	Sr Specialist Eng Consultant	MC 07-11-19 Holiday Inn Exporess - Hotel room for G Ramirez	EXP	1.00	173.380	157.62 ✓	173.38
	7/31/2019	gerdingm	Sr Specialist Eng Consultant	MC 07-10-19 Buffalo Wings - Dinner M Gerding & G Ramirez	EXP	1.00	44.170	40.15 ✓	44.17
	7/31/2019	gerdingm	Sr Specialist Eng Consultant	CASH 07-10-19 CIBO Express - Water	EXP	1.00	3.560	3.24 ✓	3.56
	7/31/2019	gerdingm	Sr Specialist Eng Consultant	CASH - 07-11-2019 - UBER - Trip from Hotel to Project Site	EXP	1.00	16.170	14.70 ✓	16.17
	7/31/2019	gerdingm	Sr Specialist Eng Consultant	CASH - 07-10-2019 - UBER - Trip from Airport to Hotel	EXP	1.00	13.790	12.54 ✓	13.79
	7/31/2019	gerdingm	Sr Specialist Eng Consultant	MC 07-11-19 Costa Mesa - Lunch	EXP	1.00	52.060	47.33 ✓	52.06
	7/31/2019	gerdingm	Sr Specialist Eng Consultant	CASH - 07-11-2019 - UBER - Trip from Harlingen to McAllen	EXP	1.00	42.570	38.70 ✓	42.57
	7/31/2019	gerdingm	Sr Specialist Eng Consultant	CASH - 07-11-2019 - UBER - Trip from Edinburg to Airport	EXP	1.00	22.330	20.30 ✓	22.33
	7/31/2019	gerdingm	Sr Specialist Eng Consultant	CASH - 07-11-19 - UBER - Trip from McAllen to Edinburg	EXP	1.00	20.690	18.81 ✓	20.69
	7/9/2019	ramirezg	Engineering Consultant 4	AMEX GBT - 7/9/19 - United - Flight Reservations	EXP	1.00	693.010	630.01 ✓	693.01
	7/10/2019	ramirezg	Engineering Consultant 4	CASH - 7/10/19 - EcoPark2 - Parking	EXP	1.00	15.400	14.00 ✓	15.40
	7/10/2019	ramirezg	Engineering Consultant 4	CASH - 7/10/19 - Cibo Express - Food	EXP	1.00	8.490	7.72 ✓	8.49
	7/11/2019	ramirezg	Engineering Consultant 4	CASH - 7/11/19 - McAllen Int. Airport - Food	EXP	1.00	12.120	11.02 ✓	12.12
<b>General Project Expense</b>						<b>Task Totals</b>	16.00	1,796.36	<b>\$ 1,975.98</b>
EXP - MILEAGE	7/10/2019	gerdingm	Sr Specialist Eng Consultant	travel from office to IAH for flight to McAllen	EXP	20.00	0.580	11.60	11.60
	7/11/2019	gerdingm	Sr Specialist Eng Consultant	travel from IAH	EXP	31.50	0.580	18.27	18.27
	<b>Mileage - Unit 0.79</b>						<b>Task Totals</b>	51.50	29.87
EXP - SOFTWARE	7/20/2019	Software	Software Charges	Software charge - CAD	EXP	3.00 ✓	12.000	36.00	36.00
	<b>Software - 12 CAD / 25 SACS</b>						<b>Task Totals</b>	3.00	36.00
<b>Expenses Total</b>						<b>70.50</b>			<b>\$ 2,041.85</b>

Invoice No: **INV063509**

Page 6

Task ID	Date	User ID	Employee Class	Billing Description	Pay Code	Qty	Bill Rate	Cost Amount	Bill Amount
---------	------	---------	----------------	---------------------	----------	-----	-----------	-------------	-------------

Total Invoice Amount: \$ 24,102.35



**CONSOLIDATED ASSET MANAGEMENT SERVICES, LLC**

919 Milam Street, Suite 2300 Houston, TX 77002-5418

TO: Lonestar Pipeline Company, LLC  
 c/o Frontera Energy Center  
 900 S Goodwin Road  
 Mission, TX 78572

Attention: Ed Fuselier  
[ed.fuselier@kindle-energy.com](mailto:ed.fuselier@kindle-energy.com)

Invoice No.: LONPIP 20190930  
 Date: 11-Oct-2019  
 Due Date: 26-Oct-2019  
 Prepared by: R.Wilson 713-358-9743

Pursuant to the terms of the Pipeline Services Agreement dated 11/1/2014 by and between Consolidated Asset Management Services, LLC ("CAMS") and Lonestar Pipeline Company, LLC (d/b/a Rio Grande Interstate Pipeline LLC) ("Lonestar"); Non-Routine fees per "Exhibit 1" to the above contract:

Non-Routine Services:

**CAMS "Allocated Time for Colin Harper" related to the Dicker Road Line Relocation**

*(see attached time allocation schedule)*

TX DOT Dicker Road - August 2019 - Reimbursable by TX DOT	5.75
TX DOT Dicker Road - September 2019 - Reimbursable by TX DOT	6.00
Hours:	11.75
Rate per Hour:	250.00

**2,937.50** TxDOT Reimbursable

Other Non-Routine Services:

CAMS Trident - Locate & Mark Lines ( Inv# 068045 dated 8/31/19)	BILLED INCORRECT AMOUNT IN AUG!	3,000.00
CAMS Trident - Locate & Mark Lines ( Inv# 068521 dated 9/30/19)		5,733.50
Texas Railroad Commision - P5 Renewal Filing (Inv# P-5 Lonestar dated 8/27/19)		575.41
Enertech - Est Postage for 2019 Pipeline Mailing (Inv# POST-00389 dated 9/30/19) plus 15% markup		1,724.09
Enertech - 2019 Xchange Hosting Fee (Inv# INV-00773 dated 1/15/19)		0.00
UPS charges to TRCC for P-5 filing (Inv# 53R7R8359 dated 8/31/19)		10.19
M&H Enterprises, Inc. - August Engineering Services (Inv# INV064066 dated 9/9/19) plus 15% markup		<b>21,303.18</b>
M&H Enterprises, Inc. - August Engineering Services (Inv# INV064067 dated 9/9/19) plus 15% markup		4,522.38
Majic Valley Electric - Sept electric for rectifiers ( Inv# 290790-AUG dated 9/27/19)		72.27
Direct Energy - Sept electric ( Inv# 192760039846395 dated 10/3/19)		43.93
Direct Energy - Sept electric ( Inv# 192800039884943 dated 10/7/19)		12.12

TxDOT Reimbursable

**TOTAL AMOUNT DUE: \$ 39,934.57**

**Wire Instructions:**  
 Consolidated Asset Management  
 Services Texas, LLC  
 Amegy Bank  
 ABA#: 113011258  
 Account # 003771350

CO	Coding:						Amount
CAMSTEX	Acct	Subaccount					
LONPIP	1110000	104	000	00	00	0000	39,934.57
	1140000	104	000	00	00	0000	0.00
	3050000	104	354	00	00	0000	(2,937.50)
	3055000	104	354	00	00	0000	(36,997.07)

CAMS Time Allocation  
Name: Colin Harper  
Month: August 2019

Lonestar Pipeline O&M

<u>TX DOT - Dicker Road Line Relocation - (Reimbursable)</u>		<u>Time/ Hrs.</u>
6-Aug	Dicker Rd - Weekly Project Update Call w/ Kindle and M&H - Call Prep	0.50
	Project Call	0.25
13-Aug	Dicker Rd - Weekly Project Update Call w/ Kindle and M&H - Call Prep	1.25
	Project Call	0.50
	Call with Strike regarding Construction Agreement terms	0.50
20-Aug	Dicker Rd - Weekly Project Update Call w/ Kindle and M&H - Call Prep	0.50
	Brighton Group communication regarding land/workspace status	0.50
	Project Call	0.50
27-Aug	Dicker Rd - Weekly Project Update Call w/ Kindle and M&H - Call Prep	0.50
	Project Call	0.75
<b>Dicker Road Total</b>		<b>5.75</b>
<b>WCH Total August 2019</b>		<b>5.75</b>

**CAMS Time Allocation**  
**Name: Colin Harper**  
**Month: September 2019**

**Lonestar Pipeline O&M**

<b><u>TX DOT - Dicker Road Line Relocation - (Reimbursable)</u></b>		<b><u>Time/ Hrs.</u></b>
3-Sep	Dicker Rd - Weekly Project Update Call w/ Kindle and M&H - Call Prep Project Call	0.50 0.25
10-Sep	Dicker Rd - Weekly Project Update Call w/ Kindle and M&H - Call Prep Project Call	0.75 0.50
19-Sep	Dicker Rd - Weekly Project Update Call w/ Kindle and M&H - Call Prep Project Call	0.50 0.50
24-Sep	Dicker Rd - Weekly Project Update Call w/ Kindle and M&H - Call Prep Project Call	0.75 0.25
	Project Overview Mtg with James Poitevent (Project Mgr) and M&H	<u>2.00</u>
	<b>Dicker Road Total</b>	<b>6.00</b>
	<b>WCH Total September 2019</b>	<b>6.00</b>



M&H Enterprises Inc.  
 dba M&H Energy Services  
 19450 HWY 249, Suite 600  
 Houston, TX 77070  
 (281) 664-7222

# INVOICE

**Bill To: CAMS Midstream**

Colin Harper  
 919 Milam Street  
 Suite 2300  
 Houston, Texas 77002

Invoice Date: 9/9/2019  
 Invoice No: INV064066  
 Terms:

For services rendered for the calendar month ending **August 31, 2019**

**M&H Project No: 17MH033 Dicker Road Hidalgo County**

Inquiries can be sent to charper@camstex.com

**PROFESSIONAL SERVICES**

	Rate	Qty	Amount
Engineering Consultant 4	101.00	10.00	\$ 1,010.00
Project Controls Coordinator 2	101.00	10.00	\$ 1,010.00
Purchasing Agent 2	116.00	12.00	\$ 1,392.00
Purchasing Manager	165.00	16.00	\$ 2,640.00
Senior Project Director	200.00	17.50	\$ 3,500.00
Sr Specialist Eng Consultant	185.00	48.50	\$ 8,972.50
		114.00	\$ 18,524.50

Total Invoice Amount: **\$ 18,524.50**

3055000 104-354-72-00-000

Project Manager: R. Perego

*[Handwritten Signature]* 9.11.19  
 RE: *[Handwritten]* Lorester Pipeline  
 Dicker Road Project  
 (NOT REIMBURSABLE)

*[Handwritten]* REIMBURSABLE

Task ID	Date	User ID	Employee Class	Billing Description	Pay Code	Qty	Bill Rate	Cost Amount	Bill Amount
---------	------	---------	----------------	---------------------	----------	-----	-----------	-------------	-------------

**M&H Project No: 17MH033 Dicker Road Hidalgo County**

**Professional Services**

<i>Mae G.</i>	ENG-COST	8/13/2019	gerdingm	Sr Specialist Eng Consultant	update project cost estimate with actuals; sales tax question;	EXEMPT	3.50 ✓	185.00 ✓	647.50
		8/16/2019	gerdingm	Sr Specialist Eng Consultant	cost update	EXEMPT	3.50 ✓	185.00	647.50
	<b>Cost Estimate</b>					<b>Task Totals</b>	<b>7.00 ✓</b>		<b>\$ 1,295.00 ✓</b>
<i>Rand.</i>	ENG-PC-1	8/12/2019	peregor	Senior Project Director	Commercial bid evaluation, construction contract T&Cs	EXEMPT	2.00	200.00 ✓	400.00
		8/22/2019	peregor	Senior Project Director	Project management	EXEMPT	2.00	200.00	400.00
		8/27/2019	peregor	Senior Project Director	Weekly meeting, contract appendices	EXEMPT	4.00	200.00	800.00
		8/28/2019	peregor	Senior Project Director	Contract appendices	EXEMPT	1.00	200.00	200.00
		8/29/2019	peregor	Senior Project Director	Contract appendices	EXEMPT	3.50	200.00	700.00
	<b>Project Coordination - Management</b>					<b>Task Totals</b>	<b>12.50 ✓</b>		<b>\$ 2,500.00 ✓</b>
<i>Kasha L.</i>	ENG-PC-2	8/6/2019	linscombek	Project Controls Coordinator 2	Project Controls, Cost Report	HOURLY	0.50	101.00 ✓	50.50
		8/15/2019	linscombek	Project Controls Coordinator 2	Project Controls Coordination	HOURLY	1.00	101.00	101.00
		8/20/2019	linscombek	Project Controls Coordinator 2	Project Controls, Trans 0007 - PR8002-CBE Rev. 0	HOURLY	1.50	101.00	151.50
		8/27/2019	linscombek	Project Controls Coordinator 2	Project Controls, RFQ Discussion/Coordination	HOURLY	2.00	101.00	202.00
		8/27/2019	linscombek	Project Controls Coordinator 2	Project Controls, Project Activity Report/Cost Review	HOURLY	0.50	101.00	50.50
		8/28/2019	linscombek	Project Controls Coordinator 2	Project Controls, RFQ Coordination, Document Controls	HOURLY	2.50	101.00	252.50
		8/29/2019	linscombek	Project Controls Coordinator 2	Project Controls, RFQ Coordination	HOURLY	2.00	101.00	202.00
<b>Project Coordination - Controls</b>					<b>Task Totals</b>	<b>10.00 ✓</b>		<b>\$ 1,010.00 ✓</b>	
<i>Mae G.</i>	ENG-PC-3	8/5/2019	gerdingm	Sr Specialist Eng Consultant	Review and comment on Strike bid ✓	EXEMPT	2.00	185.00	370.00

Task ID	Date	User ID	Employee Class	Billing Description	Pay Code	Qty	Bill Rate	Cost Amount	Bill Amount
ENG-PC-3	8/6/2019	gerdingm	Sr Specialist Eng Consultant	review and comment on Strike bid; prep kmz for temporary work space ✓	EXEMPT	6.00	185.00		1,110.00
	8/12/2019	gerdingm	Sr Specialist Eng Consultant	tracker	EXEMPT	5.00	185.00		925.00
	8/13/2019	gerdingm	Sr Specialist Eng Consultant	contract issues ✓	EXEMPT	3.00	185.00		555.00
	8/14/2019	gerdingm	Sr Specialist Eng Consultant	contract issues ✓	EXEMPT	2.50	185.00		462.50
	8/19/2019	gerdingm	Sr Specialist Eng Consultant	SOW ✓	EXEMPT	4.00	185.00		740.00
	8/20/2019	gerdingm	Sr Specialist Eng Consultant	SOW ✓	EXEMPT	6.00	185.00		1,110.00
	8/21/2019	gerdingm	Sr Specialist Eng Consultant	SOW, locate change order form and appendices response; ✓	EXEMPT	8.00	185.00		1,480.00
	8/22/2019	gerdingm	Sr Specialist Eng Consultant	finish SOW, review with phil and ron ✓	EXEMPT	3.00	185.00		555.00
	8/1/2019	kleinerm	Purchasing Agent 2	Bids / Clarifications. ✓	HOURLY	1.00	116.00		116.00
	8/6/2019	kleinerm	Purchasing Agent 2	Clarifications and T&Cs ✓	HOURLY	1.00	116.00		116.00
	8/7/2019	kleinerm	Purchasing Agent 2	Clarifications. ✓	HOURLY	1.50	116.00		174.00
	8/8/2019	kleinerm	Purchasing Agent 2	CBE Update with Clarifications. ✓	HOURLY	1.50	116.00		174.00
	8/9/2019	kleinerm	Purchasing Agent 2	BOM CBE. ✓	HOURLY	1.00	116.00		116.00
	8/12/2019	kleinerm	Purchasing Agent 2	Pipe and fittings CBE. ✓	HOURLY	1.00	116.00		116.00
	8/15/2019	kleinerm	Purchasing Agent 2	CBE / expediting options / revised bids. ✓	HOURLY	2.00	116.00		232.00
	8/16/2019	kleinerm	Purchasing Agent 2	Formal Recommendation. ✓	HOURLY	0.50	116.00		58.00
	8/20/2019	kleinerm	Purchasing Agent 2	Pipe and Fittings CBE revision for fomal recommendation. ✓	HOURLY	1.00	116.00		116.00
	8/26/2019	kleinerm	Purchasing Agent 2	Strike clarifications. ✓	HOURLY	0.50	116.00		58.00
	8/23/2019	peregor	Senior Project Director	Reviewing HDD scope of work ✓	EXEMPT	1.00	200.00		200.00
	8/5/2019	ramirezg	Engineering Consultant 4	Utility Crossing Review ✓	EXEMPT	6.00	101.00		606.00
	8/6/2019	ramirezg	Engineering Consultant 4	Utility Crossing Review ✓	EXEMPT	0.50	101.00		50.50
	8/7/2019	ramirezg	Engineering Consultant 4	Plan Review with Utilities ✓	EXEMPT	1.00	101.00		101.00

*Guaranteed.*

Task ID	Date	User ID	Employee Class	Billing Description	Pay Code	Qty	Bill Rate	Cost Amount	Bill Amount
ENG-PC-3	8/14/2019	ramirezg	Engineering Consultant 4	Utility Company Communication ✓	EXEMPT	0.50	101.00		50.50
	8/15/2019	ramirezg	Engineering Consultant 4	Communications with Utility Companies ✓	EXEMPT	0.50	101.00		50.50
	8/28/2019	ramirezg	Engineering Consultant 4	Coordination with Utility Lines Company ✓	EXEMPT	1.00	101.00		101.00
	8/2/2019	smiths	Purchasing Manager	Follow up with bidders on T&C's review ✓	EXEMPT	0.50	165.00		82.50
	8/6/2019	smiths	Purchasing Manager	Continue bid review and analysis, send T&C's and contracts to bidder for comments ✓	EXEMPT	1.50	165.00		247.50
	8/7/2019	smiths	Purchasing Manager	Contract comment review, commercial analysis and clarification review ✓	EXEMPT	2.00	165.00		330.00
	8/12/2019	smiths	Purchasing Manager	CBE and review of pipe/fitting bids ✓	EXEMPT	1.00	165.00		165.00
	8/13/2019	smiths	Purchasing Manager	Schedule conference call with Strike and review terms and discussion points for call ✓	EXEMPT	0.50	165.00		82.50
	8/21/2019	smiths	Purchasing Manager	Edgen T&C's comments, appendices review and comment for construction comment ✓	EXEMPT	2.00	165.00		330.00
	8/26/2019	smiths	Purchasing Manager	Clarifications with Strike on subs, updating appendices and contract information ✓	EXEMPT	1.50	165.00		247.50
	8/27/2019	smiths	Purchasing Manager	Securing all updated contract data for construction contract, T&C's with Apex, follow up on Edgen T&C's ✓	EXEMPT	1.50	165.00		247.50
	8/28/2019	smiths	Purchasing Manager	Securing all updated contract data for construction contract, T&C's with Apex, follow up on Edgen T&C's ✓	EXEMPT	1.50	165.00		247.50
	8/29/2019	smiths	Purchasing Manager	Securing all updated contract data for construction contract ✓	EXEMPT	1.00	165.00		165.00
	8/30/2019	smiths	Purchasing Manager	Securing all updated contract data for construction contract ✓	EXEMPT	1.00	165.00		165.00
✓ Project Coordination - General					Task Totals	75.00 ✓			\$ 12,053.00
ENG-PC-5	8/6/2019	gerdingm	Sr Specialist Eng Consultant	weekly project review meeting with CAMS and Kindle ✓	EXEMPT	0.50	185.00		92.50
	8/27/2019	gerdingm	Sr Specialist Eng Consultant	mtg with follow up ✓	EXEMPT	1.50	185.00		277.50
	8/13/2019	kleinerm	Purchasing Agent 2	Strike meeting. ✓	HOURLY	1.00	116.00		116.00
	8/6/2019	peregor	Senior Project Director	Conference call, project management ✓	EXEMPT	1.00	200.00		200.00

Task ID	Date	User ID	Employee Class	Billing Description	Pay Code	Qty	Bill Rate	Cost Amount	Bill Amount
ENG-PC-5	8/13/2019	peregor	Senior Project Director	Client and contractor conference calls, follow-up ✓	EXEMPT	3.00	200.00		600.00
	8/6/2019	ramirezg	Engineering Consultant 4	Cathodic Protection Test Point Discussion ✓	EXEMPT	0.50	101.00		50.50
	8/6/2019	smiths	Purchasing Manager	Meeting with PM to review bids and review clarifications ✓	EXEMPT	0.50	165.00		82.50
	8/13/2019	smiths	Purchasing Manager	Call with Strike on commercial terms in contract ✓	EXEMPT	0.50	165.00		82.50
	8/27/2019	smiths	Purchasing Manager	Appendices review meeting and weekly status call with CAMS/ Kindle ✓	EXEMPT	1.00	165.00		165.00
<b>Project Coordination - Meetings</b>					<b>Task Totals</b>	<b>9.50</b> ✓			<b>\$ 1,666.50</b>
<b>Professional Services Total</b>						<b>114.00</b>			<b>\$ 18,524.50</b> ✓

Total Invoice Amount: \$ 18,524.50



**CONSOLIDATED ASSET MANAGEMENT SERVICES, LLC**

919 Milam Street, Suite 2300 Houston, TX 77002-5418

TO: Lonestar Pipeline Company, LLC  
 c/o Frontera Energy Center  
 900 S Goodwin Road  
 Mission, TX 78572

Attention: Ed Fuselier

[ed.fuselier@kindle-energy.com](mailto:ed.fuselier@kindle-energy.com)

Invoice No.: LONPIP 20191031  
 Date: 11-Nov-2019  
 Due Date: 26-Nov-2019  
 Prepared by: R.Wilson 713-358-9743

Pursuant to the terms of the Pipeline Services Agreement dated 11/1/2014 by and between Consolidated Asset Management Services, LLC ("CAMS") and Lonestar Pipeline Company, LLC (d/b/a Rio Grande Interstate Pipeline LLC) ("Lonestar"); Non-Routine fees per "Exhibit 1" to the above contract:

**Non-Routine Services:**

CAMS "Allocated Time for Colin Harper" related to the Line Strike Repair, Audit & Dicker Road Line Relocation

(see attached time allocation schedule)

Line Strike Repair	1.50		
TRCC OQ Audit	3.00		
TX DOT Dicker Road - Reimbursable by TX DOT	3.75	3.75 x 250 = 937.50	TxDOT Reimbursable
Hours:	8.25		
Rate per Hour:	250.00		2,062.50

**Other Non-Routine Services:**

CAMS Trident - ROW Clearing ( Inv# 069010 dated 10/22/19)	37,324.40	
CAMS Trident - Locate & Mark Lines ( Inv# 069122 dated 10/31/19)	3,990.40	
PIC - Inspection Services for Dicker R Relo (Inv# Lonestar 1 dated 10/31/19) Reimbursable by TX DOT	3,597.50	
PIC - Inspection Services for Dicker Rd Relo (Inv# Lonestar 2 dated 11/3/19) Reimbursable by TX DOT	772.50	TxDOT Reimbursable
PIC - Inspection Services for Dicker Rd Relo (Inv# Lonestar 3 dated 11/3/19) Reimbursable by TX DOT	3,045.00	
PIC - Inspection Services for Line Strike Repair (Inv# Lonestar 4 dated 11/3/19)	3,150.00	
Enertech - 2019 Public Awareness Liaison Program (Inv# INV-01201 dated 10/24/19)	5,524.04	
Enertech - Postage Trueup for 2019 Pipeline Mailing (Inv# POST-00401 dated 10/24/19) plus 15% markup	40.39	
SRP & Associates - Consulting & Expenses for TRCC Audit ( Inv# P-8 dated 11/7/19)	5,450.99	
M&H Enterprises - Eng Svs (Inv# INV064340 dated 10/7/19) plus 15% markup Reimbursable by TX DOT	11,241.31	
M&H Enterprises, Inc. - October Engineering Services (Inv# INV064342 dated 10/7/19) plus 15% markup	3,227.76	TxDOT Reimbursable
M&H Enterprises - Eng Svs (Inv# INV064628 dated 11/7/19) plus 15% markup Reimbursable by TX DOT	24,764.55	
M&H Enterprises, Inc. - Nov Engineering Services (Inv# INV064629 dated 11/7/19) plus 15% markup	6,742.45	
Majic Valley Electric - October electric for rectifiers ( Inv# 290790-OCT dated 10/28/19)	69.37	
Direct Energy - October electric ( Inv# 193050040153294 dated 11/1/19)	40.58	
Direct Energy - October electric ( Inv# 193080040175571 dated 11/4/19)	12.12	
Texas Excavation Safety System - Sep message fees ( Inv# 19-17636 dated 9/30/19)	95.95	

TOTAL AMOUNT DUE:

\$ 111,151.81

*RWJ*

**Wire Instructions:**  
 Consolidated Asset Management Services Texas, LLC  
 Amegy Bank  
 ABA#: 113011258  
 Account # 003771350

CO	Coding:						Amount
CAMSTEX	Acct		Subaccount				
LONPIP	1110000	104	000	00	00	0000	111,151.81
	1140000	104	000	00	00	0000	0.00
	3050000	104	354	00	00	0000	(2,062.50)
	3055000	104	354	00	00	0000	(109,089.31)

**CAMS Time Allocation**  
**Name: Colin Harper**  
**Month: October 2019**

**Lonestar Pipeline O&M**

**TX DOT - Dicker Road Line Relocation - (TX DOT Reimbursable)**

**Time/ Hrs.**

1-Oct	Dicker Rd - Weekly Project Update Call w/ Kindle and M&H - Call Prep	0.50
	Project Call	0.25
9-Oct	Dicker Rd - Weekly Project Update Call w/ Kindle and M&H - Call Prep	0.75
	Project Call	0.25
15-Oct	Dicker Rd - Weekly Project Update Call w/ Kindle and M&H - Call Prep	0.25
	Project Call	0.25
22-Oct	Dicker Rd - Weekly Project Update Call w/ Kindle and M&H - Call Prep	0.50
	Project Call	0.25
	Call with Alicia Rodriguez regarding workspace agreements	0.50
29-Oct	Dicker Rd - Weekly Project Update Call w/ Kindle and M&H	0.25

**Dicker Road Total **3.75****

**TRRC OQ Audit**

**Time/ Hrs.**

14-Oct	Meet with Simon Pena to prep for December OQ Audit for LSPL	0.50
15-Oct	Met with Simon Pena; Reviewed OQ Plan Updates	0.75
16-Oct	Reviewed Updated OQ Manual	1.75

**TRRC OQ Audit Total **3.00****

**Line Strike Repair**

**Time/ Hrs.**

22-Oct	Hidalgo County Water - Line Strike Repair Call with Kindle Team and M&H	0.25
29-Oct	Hidalgo County Water - Line Strike Repair Call with Kindle Team and M&H	0.25
30-Oct	Daily Construction Call with James Poitevent and M&H	0.25
	Daily Report to LSPL Team	0.25
31-Oct	Daily Construction Call with James Poitevent and M&H	0.25
	Daily Report to LSPL Team	0.25

**Line Strike Repair Total **1.50****

**WCH Total October 2019 **8.25****

P I C

A Pipeline Inspection Company  
1705 Richardson Road  
Liberty, Texas 77575

389988

# Invoice

Date:	October 31, 2019
Invoice #:	Lonestar 1
Customer ID:	CAMSTEX
Purchase Order #	None
Payment Due by:	Due upon receipt

**Bill To:**

CAMS Midstream, LLC  
919 Milam Street  
Suite 2300  
Houston, TX 77002  
713-358-9700

**Ship To (If Different):**

Description	Line Total
Time Allocation for 10/24/19 - 10/27/19: 30 Hours (as attached)	2,400.00
Expenses for pay period 2019 (as attached)	-
Vehicle Mileage: 610 miles at \$1.25/mile	762.50
Per Diem: 3 days at \$145/day	435.00
<b>RECEIVED</b>	
NOV 7 2019	
AIP DEPARTMENT	

**Special Notes and Instructions**

Charge to: 17MH033 Dicker Road Project  
Please make check payable to P I C and mail to address below

3055000 104,354.72-00.000

Subtotal	\$	3,597.50
Sales Tax Rate	%	0.00
Sales Tax	\$	-
S&H	\$	-
Discount	\$	-
<b>Total</b>	<b>\$</b>	<b>3,597.50</b>

Make all checks payable to P I C

**Thank you for your business!**

Should you have any enquiries concerning this invoice, please contact James Poitevent

1705 Richardson, Liberty, TX 77575  
Tel: 713-201-6644 poitevent@att.net

*(Signature)* 11.04.19  
Lonestar P/L  
Dicker Rd.  
Relocation  
(TXDOT)  
- R2:IMBURSABLE -

# James Poitevent

## Time Card

Employee James Poitevent  
 [Street Address] Lonestar Invoice 1  
 [City, ST ZIP Code] \_\_\_\_\_  
 Week ending: 10/27/2019

Manager: James Poitevent  
 Employee phone: 713-201-6644  
 Employee e-mail: poitevent@att.net

Day	Date	Regular Hours	Overtime	Per Diem	Expense	Total
Monday	10/21/2019					
Tuesday	10/22/2019					
Wednesday	10/23/2019					
Thursday	10/24/2019	10.00		1	420.00	
Friday	10/25/2019	10.00		1	140.00	
Saturday	10/26/2019	10.00		1	50.00	
Sunday	10/27/2019					
<b>Total hours</b>		<b>30.00</b>		<b>3</b>	<b>610.00</b>	
<b>Rate per hour</b>		\$ 80.00	\$ 120.00	\$145.00	\$1.25	
<b>Total pay</b>		\$ 2,400.00	\$ -	\$ 435.00	\$ 762.50	\$ 3,597.50 ✓

*M. SAGE/MISS*

James Poitevent  
 Employee signature \_\_\_\_\_ Date \_\_\_\_\_  
  
 Manager signature \_\_\_\_\_ Date 11-02-19



# James Poitevent

## Time Card

Employee James Poitevent  
 [Street Address] Invoice - Lonestar 2 (office meeting HTX)  
 [City, ST ZIP Code] \_\_\_\_\_  
 Week ending: 9/29/2019

Manager: James Poitevent  
 Employee phone: 713-201-6644  
 Employee e-mail: poitevent@att.net

Day	Date	Regular Hours	Overtime	Per Diem	Expense	Total
Monday						
Tuesday	9/24/2019	8.00			106.00	
Wednesday	9/25/2019					
Thursday	9/26/2019					
Friday	9/27/2019					
Saturday	9/28/2019					
Sunday	9/29/2019					
<b>Total hours</b>		<b>8.00</b>			<b>106.00</b>	
<b>Rate per hour</b>		\$ 80.00	\$ 120.00	\$ 145.00	\$ 1.25	
<b>Total pay</b>		\$ 640.00	\$ -	\$ -	\$ 132.50	\$ 772.50 ✓

James Poitevent

Employee signature



Manager signature

Date

11.04.19

Date

**P I C**

A Pipeline Inspection Company  
1705 Richardson Road  
Liberty, Texas 77575

389986

**Invoice**

Date:	November 3, 2019
Invoice #:	Lonestar 3
Customer ID:	CAMSTEX
Purchase Order #	None
Payment Due by:	Due upon receipt

**Bill To:**

CAMS Midstream, LLC  
919 Milam Street  
Suite 2300  
Houston, TX 77002  
713-358-9700

**Ship To (If Different):**

Description	Line Total
Time Allocation for 10/28/19 thru 10/30/19: 30 Hours (as attached)	2,400.00
Expenses for pay period 2019 (as attached)	-
Vehicle Mileage: 168 miles at \$1.25/mile	210.00
Per Diem 3 days at 145.00 per day	435.00
<b>RECEIVED</b> NOV 7 2019 AIP DEPARTMENT	

**Special Notes and Instructions**  
 Charge to: 17MH033 Dicker Road Project  
 Please issue check to P I C and mail to address below

3055000 164-354-72-0010000

Subtotal	\$	3,045.00
Sales Tax Rate	%	0.00
Sales Tax	\$	-
S&H	\$	-
Discount	\$	-
<b>Total</b>	<b>\$</b>	<b>3,045.00</b>

Make all checks payable to P I C

**Thank you for your business!**

Should you have any enquiries concerning this invoice, please contact James Poitevent

1705 Richardson, Liberty, TX 77575  
Tel: 713-201-6644 poitevent@att.net

*[Signature]* 11.06.19  
 RE: Lonestar P/L  
 Dicker Rd  
 Relocation  
 (TXDOT)  
 REIMBURSABLE -

# James Poitevent

## Time Card

Employee James Poitevent  
 [Street Address] Lonestar Invoice 3  
 [City, ST ZIP Code] \_\_\_\_\_  
 Week ending: 11/3/2019

Manager: James Poitevent  
 Employee phone: 713-201-6644  
 Employee e-mail: poitevent@att.net

Day	Date	Regular Hours	Overtime	Per Diem	Expense	Total
Monday	10/28/2019	10.00		1	93.00	
Tuesday	10/29/2019	10.00		1	75.00	
Wednesday	10/30/2019	10.00		1		
Thursday	10/31/2019					
Friday	11/1/2019					
Saturday	11/2/2019					
Sunday	11/3/2019					
<b>Total hours</b>		<b>30.00</b>		<b>3</b>	<b>168.00</b>	
<b>Rate per hour</b>		\$ 80.00	\$ 120.00	\$ 145.00	\$ 1.25	
<b>Total pay</b>		\$ 2,400.00	\$ -	\$ 435.00	\$ 210.00	\$ 3,045.00 ✓

James Poitevent  
 Employee signature \_\_\_\_\_ Date \_\_\_\_\_  
 \_\_\_\_\_ Date 11.03.19  
 Manager signature \_\_\_\_\_

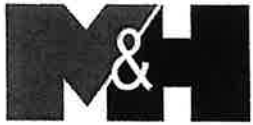

M&H Enterprises Inc.  
 dba M&H Energy Services  
 19450 HWY 249, Suite 600  
 Houston, TX 77070  
 (281) 664-7222



388312

**INVOICE**

**Bill To: CAMS Midstream**

Colin Harper  
 919 Milam Street  
 Suite 2300  
 Houston, Texas 77002

Invoice Date: 10/7/2019  
 Invoice No: INV064340  
 Terms:

For services rendered for the calendar month ending **September 30, 2019**

**M&H Project No: 17MH033 Dicker Road Hidalgo County**

Inquiries can be sent to charper@camstex.com

**PROFESSIONAL SERVICES**

Engineering Consultant 4 *CONSTANTINO*  
 Project Controls Coordinator 2 *KARLA*  
 Purchasing Agent 2  
 Purchasing Manager *STACY*  
 Senior Project Director *PEREGO*  
 Sr Specialist Eng Consultant *GEORGE*

Rate	Qty	Amount
101.00 ✓	5.50 ✓	\$ 555.50 ✓
101.00 ✓	7.75 ✓	\$ 782.75 ✓
116.00 ✓	4.00 ✓	\$ 464.00 ✓
165.00 ✓	18.50 ✓	\$ 3,052.50 ✓
200.00 ✓	16.00 ✓	\$ 3,200.00 ✓
185.00 ✓	9.00 ✓	\$ 1,665.00 ✓
	60.75	\$ 9,719.75

**SEPT. 2019  
 EXPENSES**

\$ 55.30

Total Invoice Amount: **\$ 9,775.05**

3055000 104-354-72-00-0000

*[Signature]* 10.09.19  
 R2: Lorester P/L  
 TXDOT Dicker Road Relocation  
 TXDOT Reimbursable  
*[Signature]*

Project Manager: R. Perego

Task ID	Date	User ID	Employee Class	Billing Description	Pay Code	Qty	Bill Rate	Cost Amount	Bill Amount
---------	------	---------	----------------	---------------------	----------	-----	-----------	-------------	-------------

**M&H Project No: 17MH033 Dicker Road Hidalgo County**

**Professional Services**

ENG-PC-1	9/3/2019	peregor	Senior Project Director	Project management	EXEMPT	1.00	200.00		200.00
	9/4/2019	peregor	Senior Project Director	Project management	EXEMPT	1.00	200.00		200.00
	9/11/2019	peregor	Senior Project Director	Project management, NDT cost estimate	EXEMPT	1.00	200.00		200.00
	9/16/2019	peregor	Senior Project Director	Project management	EXEMPT	1.00	200.00		200.00
	9/23/2019	peregor	Senior Project Director	Project management	EXEMPT	2.00	200.00		400.00
	9/25/2019	peregor	Senior Project Director	Project management	EXEMPT	1.00	200.00		200.00
	9/26/2019	peregor	Senior Project Director	Project management	EXEMPT	1.00	200.00	✓	200.00

**Project Coordination - Management Task Totals**

**8.00** ✓

**\$ 1,600.00** ✓

ENG-PC-2	9/3/2019	linscombek	Project Controls Coordinator 2	Project Controls Coordination	HOURLY	1.00	101.00		101.00
	9/4/2019	linscombek	Project Controls Coordinator 2	Project Controls, Cost Report, Document Controls	HOURLY	1.00	101.00		101.00
	9/10/2019	linscombek	Project Controls Coordinator 2	Project Controls, Cost Report, Conf Call	HOURLY	1.00	101.00		101.00
	9/11/2019	linscombek	Project Controls Coordinator 2	Project Controls, Cost Report, Project Activity Report	HOURLY	0.50	101.00		50.50
	9/16/2019	linscombek	Project Controls Coordinator 2	Project Controls, Cost Report	HOURLY	0.50	101.00		50.50
	9/19/2019	linscombek	Project Controls Coordinator 2	Project Controls, CAMS Weekly Call	HOURLY	1.00	101.00		101.00
	9/23/2019	linscombek	Project Controls Coordinator 2	Project Controls, Weekly Cost Report	HOURLY	0.25	101.00		25.25
	9/24/2019	linscombek	Project Controls Coordinator 2	Project Controls, Weekly Call	HOURLY	1.00	101.00		101.00
	9/27/2019	linscombek	Project Controls Coordinator 2	Project Controls	HOURLY	0.50	101.00		50.50
	9/30/2019	linscombek	Project Controls Coordinator 2	Project Controls, Cost Report/PAR	HOURLY	0.50	101.00	✓	50.50

**Project Coordination - Controls Task Totals**

**7.25** ✓

**\$ 732.25** ✓

Task ID	Date	User ID	Employee Class	Billing Description	Pay Code	Qty	Bill Rate	Cost Amount	Bill Amount
ENG-PC-3	9/19/2019	gerdingm ✓	Sr Specialist Eng Consultant	update cost estimate	EXEMPT	2.00	185.00 ✓		370.00
	9/20/2019	gerdingm	Sr Specialist Eng Consultant	update cost estimate	EXEMPT	2.00	185.00		370.00
	9/5/2019	kleinerm ✓	Purchasing Agent 2	PO support / coordination	HOURLY	1.00	116.00 ✓		116.00
	9/10/2019	kleinerm	Purchasing Agent 2	PO questions / documents.	HOURLY	1.00	116.00		116.00
	9/12/2019	kleinerm	Purchasing Agent 2	Purchase Order for APEX.	HOURLY	1.00	116.00		116.00
	9/18/2019	kleinerm	Purchasing Agent 2	PO Coordination.	HOURLY	1.00	116.00		116.00
	9/3/2019	ramirezg	Engineering Consultant 4	Scope of Work Review	EXEMPT	1.00	101.00		101.00
	9/5/2019	ramirezg	Engineering Consultant 4	Utility Company Coordination	EXEMPT	0.50	101.00		50.50
	9/3/2019	smiths ✓	Purchasing Manager	Updating documents and T&C's for contracts	EXEMPT	3.00	165.00 ✓		495.00
	9/4/2019	smiths	Purchasing Manager	Continue contract document updates, reach out for additional sources on asbestos testing	EXEMPT	2.00	165.00		330.00
	9/9/2019	smiths	Purchasing Manager	Asbestos scope and bid solicitation, continue working contract issues with Strike and T&C's with subs	EXEMPT	2.00	165.00		330.00
	9/10/2019	smiths	Purchasing Manager	Update project tracker for weekly meeting	EXEMPT	1.00	165.00		165.00
	9/11/2019	smiths	Purchasing Manager	MEG/Shawcor/Strike correspondence	EXEMPT	1.00	165.00		165.00
	9/12/2019	smiths	Purchasing Manager	Vendor coordination Strike & R360	EXEMPT	1.00	165.00		165.00
	9/16/2019	smiths	Purchasing Manager	T&C's follow up with subs	EXEMPT	1.00	165.00		165.00
	9/19/2019	smiths	Purchasing Manager	Update project tracker, review construction contract and send to Strike, Apex p.o. for materials, follow up on other outstanding T&C's	EXEMPT	2.00	165.00		330.00
	9/23/2019	smiths	Purchasing Manager	Update project tracker, clarify contract status with Strike, correspondence on subs T&C's	EXEMPT	1.50	165.00		247.50
	9/24/2019	smiths	Purchasing Manager	Correspondence with Strike & subs on contract, materials, T&C's	EXEMPT	1.50	165.00		247.50
	9/30/2019	smiths	Purchasing Manager	Vendor correspondence T&C's and asbestos disposal inquiries	EXEMPT	0.50	165.00		82.50
			<b>Project Coordination - General</b>	<b>Task Totals</b>		<b>26.00</b>			<b>\$ 4,078.00</b>

Task ID	Date	User ID	Employee Class	Billing Description	Pay Code	Qty	Bill Rate	Cost Amount	Bill Amount
ENG-PC-5	9/3/2019	gerdingm	Sr Specialist Eng Consultant	weekly mtg	EXEMPT	0.50	185.00		92.50
	9/24/2019	gerdingm	Sr Specialist Eng Consultant	meeting with CAMS & onsite construction for Dicker Road, project review	EXEMPT	4.50 ✓	185.00 ✓		832.50
	9/3/2019	linscombek	Project Controls Coordinator 2	Conference Call with CAMS/Kindle	HOURLY	0.50	101.00		50.50
	9/3/2019	peregor	Senior Project Director	Conference call with client	EXEMPT	1.00	200.00		200.00
	9/10/2019	peregor	Senior Project Director	Conference call with client, project management	EXEMPT	1.00	200.00		200.00
	9/19/2019	peregor	Senior Project Director	Conference call, project management	EXEMPT	1.00	200.00		200.00
	9/24/2019	peregor	Senior Project Director	Client conference call, construction meeting	EXEMPT	5.00 ✓	200.00 ✓		1,000.00
	9/24/2019	ramirezg	Engineering Consultant 4	Construction Overview Meeting	EXEMPT	4.00	101.00		404.00
	9/3/2019	smiths	Purchasing Manager	Weekly status call	EXEMPT	0.50	165.00		82.50
	9/10/2019	smiths	Purchasing Manager	Weekly status call	EXEMPT	0.50	165.00		82.50
	9/19/2019	smiths	Purchasing Manager	Weekly conf call	EXEMPT	0.50	165.00		82.50
	9/24/2019	smiths	Purchasing Manager	Weekly project meeting	EXEMPT	0.50	165.00		82.50

**Project Coordination - Meetings Task Totals 19.50 \$ 3,309.50**

**Professional Services Total 60.75 \$ 9,719.75**

**Expenses**

EXP - MILEAGE	9/24/2019	gerdingm ✓	Sr Specialist Eng Consultant	travel to CAMS office	EXP	70.00 ✓	0.790 ✓	40.60	55.30 ✓
				Mileage - Unit 0.79	Task Totals	70.00		40.60	\$ 55.30

**Expenses Total 70.00 \$ 55.30**

Total Invoice Amount: \$ 9,775.05



M&H Enterprises Inc.  
 dba M&H Energy Services  
 19450 HWY 249, Suite 600  
 Houston, TX 77070  
 (281) 664-7222

# INVOICE

**Bill To: CAMS Midstream**

Colin Harper  
 919 Milam Street  
 Suite 2300  
 Houston, Texas 77002

Invoice Date: 11/7/2019  
 Invoice No: INV064628  
 Terms:

For services rendered for the calendar month ending **October 31, 2019**

**M&H Project No: 17MH033 Dicker Road Hidalgo County**

Inquiries can be sent to charper@camstex.com

**PROFESSIONAL SERVICES**

Engineering Consultant 4  
 Lead Eng Consultant  
 Project Controls Coordinator 2  
 Project Controls Coordinator 2  
 Purchasing Manager  
 Senior Project Director  
 Sr Specialist Eng Consultant

	Rate	Qty	Amount
Engineering Consultant 4	101.00 ✓	31.50	\$ 3,181.50 ✓
Lead Eng Consultant	144.00 ✓	1.00	\$ 144.00 ✓
Project Controls Coordinator 2	101.00 ✓	20.50	\$ 2,070.50 ✓
Project Controls Coordinator 2	136.35 ✓	1.00	\$ 136.35 ✓
Purchasing Manager	165.00 ✓	16.25	\$ 2,681.25 ✓
Senior Project Director	200.00 ✓	15.00	\$ 3,000.00 ✓
Sr Specialist Eng Consultant	185.00 ✓	46.00	\$ 8,510.00 ✓
		131.25	\$ 19,723.60

**EXPENSES**

\$ 1,810.79 ✓

Total Invoice Amount: **\$ 21,534.39** ✓

3055000 104-354-72-00-000

*[Signature]* 11.08.19  
 RE: Loveston P/L  
 Dicker Road / TXDOT Relocation  
 - TXDOT Reimbursable -

Project Manager: R. Perego



Task ID	Date	User ID	Employee Class	Billing Description	Pay Code	Qty	Bill Rate	Cost Amount	Bill Amount
<b>ENG-PC-3</b>	10/17/2019	gerdingm	Sr Specialist Eng Consultant	interface with Alicia Rodriguez regarding landowner on the southeast corner; discussion with Ron; welding procedure	EXEMPT	2.00	185.00		370.00
	10/21/2019	gerdingm	Sr Specialist Eng Consultant	welding procedure review and comment, API 1104 research	EXEMPT	4.00	185.00		740.00
	10/22/2019	gerdingm	Sr Specialist Eng Consultant		EXEMPT	4.00	185.00		740.00
	10/23/2019	gerdingm	Sr Specialist Eng Consultant	right of way interface with AG	EXEMPT	2.00	185.00		370.00
	10/28/2019	gerdingm	Sr Specialist Eng Consultant	project support for field inspector	EXEMPT	6.00	185.00		1,110.00
	10/29/2019	gerdingm	Sr Specialist Eng Consultant	project support for field inspector	EXEMPT	5.00	185.00		925.00
	10/30/2019	gerdingm	Sr Specialist Eng Consultant	project support for field inspector	EXEMPT	2.00	185.00		370.00
	10/31/2019	gerdingm	Sr Specialist Eng Consultant	project support for field inspector	EXEMPT	2.00	185.00		370.00
	10/14/2019	ramirezg	Engineering Consultant 4	Asbestos Disposal Requirements	EXEMPT	0.50	101.00	✓	50.50
	10/15/2019	ramirezg	Engineering Consultant 4	Workbook Development	EXEMPT	1.00	101.00		101.00
	10/17/2019	ramirezg	Engineering Consultant 4	Asbestos Disposal Procedures	EXEMPT	1.00	101.00		101.00
	10/21/2019	ramirezg	Engineering Consultant 4	Asbestos Disposal Requirement Coordination	EXEMPT	3.00	101.00		303.00
	10/22/2019	ramirezg	Engineering Consultant 4	Asbestos Disposal Site Coordination	EXEMPT	1.50	101.00		151.50
	10/22/2019	ramirezg	Engineering Consultant 4	Weekly Update Meetings	EXEMPT	0.50	101.00		50.50
	10/30/2019	ramirezg	Engineering Consultant 4	Hydrotest Procedures	EXEMPT	2.50	101.00		252.50
	10/31/2019	ramirezg	Engineering Consultant 4	Hydrotest Procedures	EXEMPT	2.00	101.00		202.00
	10/1/2019	smiths	Purchasing Manager	Update project tracker, expedite Strike contract review	EXEMPT	1.50	165.00	✓	247.50
	10/9/2019	smiths	Purchasing Manager	Coord. w/ Strike on contract, Asbestos disposal, R360 contract/credit acct	EXEMPT	1.00	165.00		165.00
	10/10/2019	smiths	Purchasing Manager	Strike contract discussions and materials logistics	EXEMPT	1.00	165.00		165.00
	10/21/2019	smiths	Purchasing Manager	Vendor/contractor correspondence, job books data gathering	EXEMPT	2.00	165.00		330.00
	10/22/2019	smiths	Purchasing Manager	Vendor/contractor correspondence, job books data gathering	EXEMPT	2.00	165.00		330.00

*Gus*

*Smiths*

Task ID	Date	User ID	Employee Class	Billing Description	Pay Code	Qty	Bill Rate	Cost Amount	Bill Amount
<b>ENG-PC-3</b>	10/24/2019	smiths	Purchasing Manager	Vendor/contractor correspondence, job books data gathering	EXEMPT	1.00	165.00		165.00
	10/25/2019	smiths	Purchasing Manager	Vendor correspondence on material status/MTR's	EXEMPT	0.50	165.00		82.50
	10/28/2019	smiths	Purchasing Manager	Working materials issues with field/vendors, searching for alternate materials to keep project schedule	EXEMPT	2.50	165.00		412.50
	10/29/2019	smiths	Purchasing Manager	Expediting materials issues, coordinate asbestos testing vendor to mobilize, reiewing MTRs for accuracy and updating job book	EXEMPT	1.50	165.00		247.50
	10/30/2019	smiths	Purchasing Manager	Correspondence with site and subs on billing information, updating job books	EXEMPT	0.50	165.00		82.50
	10/31/2019	smiths	Purchasing Manager	Project procurement support, vendor correspondence, updating job book	EXEMPT	1.00	165.00		165.00
	<b>Project Coordination - General</b>					<b>Task Totals</b>	<b>55.00</b>		
<b>ENG-PC-4</b>	10/24/2019	gerdingm	Sr Specialist Eng Consultant	travel to McAllen Texas	EXEMPT	4.00	185.00 ✓		740.00
	10/25/2019	gerdingm	Sr Specialist Eng Consultant	meet with JP, visit job site with JP, ciscuss easment issues with Alicia, visit with Strike; visit with Sergio at power plant, update Segio regarding planns to replace two segments of pipe; travel from McAllen to Houston	EXEMPT	12.00	185.00		2,220.00
	10/26/2019	gerdingm	Sr Specialist Eng Consultant	discuussion with RP, AR; email to Collin; researsch P-4 history at RRC	EXEMPT	1.00	185.00		185.00
	10/23/2019	ramirezg	Engineering Consultant 4	Site Visit Preparation	EXEMPT	1.00	101.00 ✓		101.00
	10/24/2019	ramirezg	Engineering Consultant 4	Travel Time	EXEMPT	6.00	101.00		606.00
	10/25/2019	ramirezg	Engineering Consultant 4	Meeting and Travel Time	EXEMPT	12.00	101.00		1,212.00
<b>Project Coordination - Site Visit</b>					<b>Task Totals</b>	<b>36.00</b> ✓			<b>\$ 5,064.00</b> ✓
<b>ENG-PC-5</b>	10/9/2019	gerdingm	Sr Specialist Eng Consultant	Weekly progress meeting with CAMS and Lone Star pipeline	EXEMPT	0.50	185.00		92.50
	10/1/2019	peregorg	Senior Project Director	Conference call, project management	EXEMPT	1.00	200.00		200.00
	10/9/2019	peregorg	Senior Project Director	Conference call, project management	EXEMPT	1.00	200.00		200.00
	10/15/2019	peregorg	Senior Project Director	Conference call, project management	EXEMPT	1.00	200.00		200.00

*MARR*

*GUS*

*TEAM*

Task ID	Date	User ID	Employee Class	Billing Description	Pay Code	Qty	Bill Rate	Cost Amount	Bill Amount
ENG-PC-5	10/29/2019	peregor	Senior Project Director	Conference call, project management	EXEMPT	1.00	200.00		200.00
	10/15/2019	ramirezg	Engineering Consultant 4	Weekly Status Meeting	EXEMPT	0.50	101.00		50.50
	10/1/2019	smiths	Purchasing Manager	Discuss action items with PM	EXEMPT	0.25	165.00		41.25
	10/9/2019	smiths	Purchasing Manager	Weekly project team call	EXEMPT	0.50	165.00		82.50
	10/22/2019	smiths	Purchasing Manager	Weekly status meeting	EXEMPT	0.50	165.00		82.50
	10/29/2019	smiths	Purchasing Manager	Weekly project team meeting	EXEMPT	0.50	165.00		82.50
					<b>Project Coordination - Meetings</b>	<b>Task Totals</b>	<b>6.75</b>		
PL-RC	10/22/2019	mccauleyk	Lead Eng Consultant	B31.8 Calculations Review	EXEMPT	1.00	144.00		144.00
					<b>Road Crossing Exhibits</b>	<b>Task Totals</b>	<b>1.00</b>		
<b>Professional Services Total</b>						<b>131.25</b>			<b>\$ 19,723.60</b>

**Expenses**

EXP - MARK UP	10/29/2019	gerdingm	Sr Specialist Eng Consultant	cash 10-25-2019 Enterprise - car rental	EXP	1.00	73.810	67.10	73.81
	10/29/2019	gerdingm	Sr Specialist Eng Consultant	Lunch - M gerding, Gustavo Ramirrez & James Poitevent; inspector mob and orientationcash 10-25-2019 Danny's #3 - lunch	EXP	1.00	66.330	60.30	66.33
	10/29/2019	gerdingm	Sr Specialist Eng Consultant	cash 10-25-2019 Houston Airport System - parking	EXP	1.00	37.400	34.00	37.40
	10/29/2019	gerdingm	Sr Specialist Eng Consultant	cash 10-25-2019 Fairfield by Marriott - Hotel	EXP	1.00	118.910	108.10	118.91
	10/30/2019	peregor	Senior Project Director	MC - 10/23 - United - Gerding, Ramirez - Pre-job walk	EXP	1.00	1,286.120	1,169.20	1,286.12
	10/23/2019	ramirezg	Engineering Consultant 4	MC - 10/23/19 - Fairview by Marriott - Hotel Reservation	EXP	1.00	118.910	108.10	118.91
	10/24/2019	ramirezg	Engineering Consultant 4	MC - 10/24/19 - Copper Moon Bar and Grill - Dinner for Gustavo and Mark G.	EXP	1.00	35.370	32.15	35.37
	10/26/2019	ramirezg	Engineering Consultant 4	MC - 10/26/19 - New South Parking - Airport Parking	EXP	1.00	37.400	34.00	37.40
					<b>General Project Expense</b>	<b>Task Totals</b>	<b>8.00</b>		<b>1,612.95</b>

MARK AND GUS

Task ID	Date	User ID	Employee Class	Billing Description	Pay Code	Qty	Bill Rate	Cost Amount	Bill Amount
<b>EXP - MILEAGE</b>	10/29/2019	gerdingm	Sr Specialist Eng Consultant	mileage from IAH to home on 10-25-2019	EXP	31.50	0.580	18.27	18.27
	10/29/2019	gerdingm	Sr Specialist Eng Consultant	mileage to IAH on 10-24-2019	EXP	31.50	0.580	18.27	18.27
<b>Mileage - Unit 0.79</b>						<b>Task Totals</b>		36.54	<b>\$ 36.54</b>
<b>Expenses Total</b>						<b>71.00</b>			<b>\$ 1,810.79</b>

Total Invoice Amount: \$ 21,534.39



**CONSOLIDATED ASSET MANAGEMENT SERVICES, LLC**

919 Milam Street, Suite 2300 Houston, TX 77002-5418

TO: Lonestar Pipeline Company, LLC  
 c/o Frontera Energy Center  
 900 S Goodwin Road  
 Mission, TX 78572

Attention: Ed Fuselier  
[ed.fuselier@kindle-energy.com](mailto:ed.fuselier@kindle-energy.com)

Invoice No.: LONPIP 20191130  
 Date: 11-Dec-2019  
 Due Date: 26-Dec-2019  
 Prepared by: R.Wilson  
 713-358-9743

Pursuant to the terms of the Pipeline Services Agreement dated 11/1/2014 by and between Consolidated Asset Management Services, LLC ("CAMS") and Lonestar Pipeline Company, LLC (d/b/a Rio Grande Interstate Pipeline LLC) ("Lonestar"); Non-Routine fees per "Exhibit 1" to the above contract:

**Non-Routine Services:**

**CAMS "Allocated Time for Colin Harper" related to the Line Strike Repair, Audit & Dicker Road Line Relocation**

*(see attached time allocation schedule)*

Line Strike Repair	4.00		
TX DOT Dicker Road - Reimbursable by TX DOT	<b>12.75</b>	12.75 x 250 =	<b>3,187.50</b> TxDOT Reimbursable
Hours:	16.75		
Rate per Hour:	250.00		4,187.50

**Other Non-Routine Services:**

CAMS Trident - Test Station Install ( Inv# 069492 dated 11/30/19)	Reimbursable by TXDOT	<b>7,230.00</b>	
CAMS Trident - Locate and Mark Lines ( Inv# 069479 dated 11/30/19)		1,406.89	TxDOT Reimbursable
PIC - Inspection Services for Dicker R Relo (Inv# Lonestar 7 dated 11/17/19)	Reimbursable by TX DOT	<b>2,970.00</b>	
PIC - Inspection Services for Dicker Rd Relo (Inv# Lonestar 6 dated 11/10/19)	Reimbursable by TX DOT	3,197.50	
PIC - Inspection Services for Dicker Rd Relo (Inv# Lonestar 8 dated 11/17/19)	Reimbursable by TX DOT	<b>6,513.75</b>	TxDOT Reimbursable
PIC - Inspection Services for Dicker Rd Relo (Inv# Lonestar 9 dated 11/28/19)	Reimbursable by TX DOT	<b>6,432.50</b>	Reimbursable
SRP & Associates - Consulting & Expenses for TRCC Audit ( Inv# P-10 dated 12/5/19)		7,471.03	
M&H Enterprises - Eng Svs (Inv# INV064629 dated 11/7/19) plus 15% markup	Reimbursable by TX DOT	6,742.45	
M&H Enterprises - Eng Svs (Inv# INV064628 dated 11/7/19) plus 15% markup	Reimbursable by TX DOT	24,764.55	Duplicate from 20191031
Majic Valley Electric - November electric for rectifiers ( Inv# 290790-NOV dated 11/26/19)		34.73	
Direct Energy - November electric ( Inv# 193400040499624 dated 12/6/19)		12.12	
Direct Energy - November electric ( Inv# 193370040452717 dated 12/3/19)		12.23	
Texas Excavation Safety System - Oct message fees ( Inv# 19-19967 dated 10/31/19)		84.55	

TOTAL AMOUNT DUE:

**\$ 71,059.80**

**Wire Instructions:**  
 Consolidated Asset Management  
 Services Texas, LLC  
 Amegy Bank  
 ABA#: 113011258  
 Account # 003771350

CO	Acct	Subaccount	Amount
CAMSTEX	1110000	104 000 00 0000	71,059.80
LONPIP	1140000	104 000 00 0000	0.00
	3050000	104 354 00 0000	(4,187.50)
	3055000	104 354 00 0000	(66,872.30)

CAMS Time Allocation  
 Name: Colin Harper  
 Month: November 2019

Lonestar Pipeline O&M

TX DOT - Dicker Road Line Relocation - (TX DOT Reimbursable)

Time/ Hrs.

1-Nov	Call regarding status of ROW Agreements	0.25
4-Nov	Call regarding status of ROW Agreements; discuss fence removal prior to start	0.25
5-Nov	Dicker Rd - Weekly Project Update Call w/ Kindle and M&H - Call Prep	0.50
11-Nov	Daily Construction Call with Field Team and M&H	0.25
	Daily Report to LSPL Team	0.25
12-Nov	Daily Construction Call with Field Team and M&H	0.25
	Daily Report to LSPL Team	0.25
12-Nov	Dicker Rd - Weekly Project Update Call w/ Kindle and M&H - Call Prep	0.75
13-Nov	Daily Construction Call with Field Team and M&H	0.25
	Daily Report to LSPL Team	0.25
14-Nov	Daily Construction Call with Field Team and M&H	0.5
	Daily Report to LSPL Team	0.25
15-Nov	Daily Construction Call with Field Team and M&H	0.25
	Daily Report to LSPL Team	0.25
16-Nov	Daily Construction Call with Field Team and M&H; several follow-up calls	2.25
18-Nov	Daily Construction Call with Field Team and M&H	0.25
	Daily Report and call with LSPL Team	0.75
19-Nov	Daily Construction Call with Field Team and M&H	0.25
	Daily Report to LSPL Team	0.25
19-Nov	Dicker Rd - Weekly Project Update Call w/ Kindle and M&H - Call Prep	0.50
20-Nov	Daily Construction Call with Field Team and M&H	0.25
21-Nov	Daily Construction Call with Field Team and M&H	0.5
	Daily Report to LSPL Team	0.25
22-Nov	Daily Construction Call with Field Team and M&H	0.5
	Daily Report to LSPL Team	0.25
23-Nov	Daily Construction Call with Field Team and M&H	0.5
25-Nov	Daily Construction Call with Field Team and M&H	0.25
	Daily Report to LSPL Team	0.25
26-Nov	Daily Construction Call with Field Team and M&H	0.25
27-Nov	Daily Construction Call with Field Team and M&H	0.25
	Daily Report to LSPL Team	0.25
3-Dec	Dicker Rd - Weekly Project Update Call w/ Kindle and M&H - Call Prep	0.50

Dicker Road Total

12.75



Invoice Date November 30, 2019  
 Invoice Number 069492  
 PO Number  
 Due Date December 30, 2019  
 Payment Terms Net 30 Days

Page 1 of 1

Work Performed for:

CONSOLIDATED ASSET MGMT SERV (TX) LLC  
 ATTN: GERRY PARKER  
 919 MILAM STREET SUITE 2300  
 HOUSTON, TX 77002

2019-1511 Test Station Install 10th/Dicker Crossing  
 Test Station Install- (D. Wylie & J.Comstock)

Description	Qty	Rate	Amount
<u>Sunday, November 24, 2019</u> November 24-26, 2019 Technicians, Truck, Mileage, Equipment & Per Diem	3.00	1,350.00	4,050.00
<u>Tuesday, November 26, 2019</u> Material	1.00	3,180.00	3,180.00

*Handwritten:* 12.09.19  
 RE: Houston Pipeline  
 Dicker Road - TXDOT  
 Test Station Replacements

**\$7,230.00**

**Invoice Total**

CAMS Trident Project#: CAMSTX-19-114

**Remit Payment To:** CAMS Trident, LLC  
 919 Milam Street  
 Suite 2300  
 Houston, TX 77002  
 Phone: 7133589796

**Wire Instructions:**

Receiving Bank: Amegy Bank, N.A  
 Beneficiary: CAMS Trident, LLC  
 Account: 0054030273  
 ABA: 113011258

*Handwritten:* - D. WYLIE -



# Time Ticket

Client: Lonestar

Line #: \_\_\_\_\_

Description: Test Station Install

Date: 11-24-2019

Location: Mission

AFE/Job #: \_\_\_\_\_

State: Texas

CAMS Job #: \_\_\_\_\_

2019-1511

Time Start:	12:00 PM	Lunch:	
Time Stop:	6:00 PM		
Technician:	Deven Wylie	Hours:	6 (Per Diem)
Technician:	John Comstock	Hours:	6 (11:00am – 5:00pm) (Per Diem)
Technician:		Hours:	
Technician:		Hours:	
Technician:		Hours:	
Vehicle:	CT-118	Mileage:	370
Vehicle:		Mileage:	
Vehicle:		Mileage:	
Equipment:			
Task:	Drove to Mission Texas		
Task:			
Task:			
Quantity	Items Purchased	Quantity	Items Purchased

Client Rep: \_\_\_\_\_

Technician: D. Wylie



# Time Ticket

Client: <u>Conestar</u>	Line #: _____
Description: <u>Test Station install</u>	Date: <u>11-25-19</u>
Location: <u>Missiou</u>	AFE/P.O.#: _____
State: <u>TX</u>	CAMS Job #: <u>2019-1511</u>

Time Start: <u>7:00a</u>	Lunch: _____
Time Stop: <u>5:00p</u>	
Technician: <u>Deven Wylie</u>	Hours: <u>10 (Per Diem)</u>
Technician: <u>John Constock</u>	Hours: <u>10 (Per Diem)</u>
Technician: _____	Hours: _____
Technician: _____	Hours: _____
Technician: _____	Hours: _____
Vehicle: <u>CT-118</u>	Mileage: <u>40</u>
Vehicle: _____	Mileage: _____
Vehicle: _____	Mileage: _____

Equipment:	<u>(2) Test Stations</u>
	<u>Pin Brazer</u>
	<u>(2) Bull Pins</u>
	<u>500' #10 wire</u>
Task:	<u>Installed 2 test stations &amp; pin brazed to pipe.</u>

Quantity	Items Purchased	Quantity	Items Purchased

Client Rep: \_\_\_\_\_ Technician: Deven Wylie



# Time Ticket

Client: Lonestar Line #: \_\_\_\_\_  
 Description: Test station install Date: 11-26-19  
 Location: Mission AFE/P.O.#: \_\_\_\_\_  
 State: TX CAMS Job #: 2019-1511

Time Start:	<u>7:00a</u>	Lunch:	
Time Stop:	<u>5:00p</u>		
Technician:	<u>Deven Wylie</u>	Hours:	<u>10</u>
Technician:	<u>John Constock</u>	Hours:	<u>8 (7:00am - 3:00pm)</u>
Technician:		Hours:	
Technician:		Hours:	
Technician:		Hours:	
Vehicle:	<u>CT-118</u>	Mileage:	<u>370</u>
Vehicle:		Mileage:	
Vehicle:		Mileage:	

Equipment:

---



---



---



---

Task: finished re-install of bulk pens & drove back to Houston

Quantity	Items Purchased	Quantity	Items Purchased

Client Rep: \_\_\_\_\_ Technician: Deven Wylie

391411

# Invoice

## P I C

A Pipeline Inspection Company  
1705 Richardson Road  
Liberty, Texas 77575

Date:	November 17, 2019
Invoice #:	Lonestar 7
Customer ID:	CAMSTEX
Purchase Order #:	None
Payment Due by:	Due upon receipt

### Bill To:

CAMS Midstream, LLC  
919 Milam Street  
Suite 2300  
Houston, TX 77002  
713-358-9700

### Ship To (If Different):

Description	Line Total
Time Allocation for 11/7/19 thru 11/9/19: 30 Hours (as attached)	2,400.00
Expenses for pay period 2019 (as attached)	-
Vehicle Mileage: 108 miles at \$1.25/mile	135.00
Per Diem: 3 days a \$145.00 per day	435.00

RECEIVED  
NOV 21 2019  
A/P DEPARTMENT

### Special Notes and Instructions

Charge to: 17 MH 033 Dicker Road Project  
Please issue check to P I C and mail to address below  
  
30 55000 104-354-72-00-000

Subtotal	\$	2,970.00
Sales Tax Rate	%	0.00
Sales Tax	\$	-
S&H	\$	-
Discount	\$	-
<b>Total</b>	<b>\$</b>	<b>2,970.00</b>

 → Make all checks payable to P I C  
**Thank you for your business!**

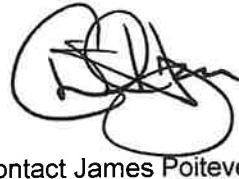
  
11.18.19  
PE: LSPL  
Dicker Rd

Should you have any enquiries concerning this invoice, please contact James Poitevent

DOT REIMBURSABLE

# James Poitevent

## Time Card

Employee James Poitevent  
 [Street Address] Lonestar Invoice 7  
 [City, ST ZIP Code] \_\_\_\_\_  
 Week ending: 11/10/2019

Manager: James Poitevent  
 Employee phone: 713-201-6644  
 Employee e-mail: poitevent@att.net

Day	Date	Regular Hours	Overtime	Per Diem	Expense	Total
Monday	11/4/2019					
Tuesday	11/5/2019					
Wednesday	11/6/2019					
Thursday	11/7/2019	10.00		1	55.00	
Friday	11/8/2019	10.00		1	33.00	
Saturday	11/9/2019	10.00		1	20.00	
Sunday	11/10/2019					
<b>Total hours</b>		<b>30.00</b>		<b>3</b>	<b>108.00</b>	
<b>Rate per hour</b>		\$ 80.00	\$ 120.00	\$145.00	\$1.25	
<b>Total pay</b>		\$ 2,400.00	\$ -	\$ 435.00	\$ 135.00	\$ 2,970.00

James Poitevent  
 Employee signature \_\_\_\_\_ Date \_\_\_\_\_  
  
 Manager signature \_\_\_\_\_ Date 11.18.19

391414

# Invoice

**P I C**

A Pipeline Inspection Company  
1705 Richardson Road  
Liberty, Texas 77575

Date:	November 17, 2019
Invoice #:	Lonestar 8
Customer ID:	CAMSTEX
Purchase Order #	None
Payment Due by:	Due upon receipt

**Bill To:**

CAMS Midstream, LLC  
919 Milam Street  
Suite 2300  
Houston, TX 77002  
713-358-9700

**Ship To (If Different):**

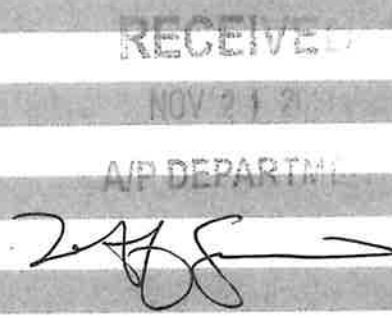
Description	Line Total
Time Allocation for 11/11/19 thru 11/16/19: 67 Hours (as attached)	5,360.00
Expenses for pay period 2019 (as attached)	-
Vehicle Mileage: 227 miles at \$1.25/mile	283.75
Per Diem: 6 days a \$145.00 per day	870.00
	

**Special Notes and Instructions**

Charge to: 17 MH 033 Dicker Road Project  
Please issue check to P I C and mail to address below  
  
3055000 104-354-7200-000

Subtotal	\$	6,513.75
Sales Tax Rate	%	0.00
Sales Tax	\$	-
S&H	\$	-
Discount	\$	-
<b>Total</b>	<b>\$</b>	<b>6,513.75</b>

Make all checks payable to P I C

**Thank you for your business!**

Should you have any enquiries concerning this invoice, please contact James Poitevent

  
11.18.19  
22: LSP  
Dicker Rd.

**DOT REIMBURSABLE**

# James Poitevent

## Time Card

Employee James Poitevent

Manager: James Poitevent

[Street Address] Lonestar Invoice 8

Employee phone: 713-201-6644

[City, ST ZIP Code] \_\_\_\_\_

Employee e-mail: poitevent@att.net

Week ending: 11/17/2019

Day	Date	Regular Hours	Overtime	Per Diem	Expense	Total
Monday	11/11/2019	12.00		1	45.00	
Tuesday	11/12/2019	12.00		1	26.00	
Wednesday	11/13/2019	11.00		1	38.00	
Thursday	11/14/2019	11.00		1	44.00	
Friday	11/15/2019	11.00		1	42.00	
Saturday	11/16/2019	10.00		1	32.00	
Sunday	11/17/2019					
<b>Total hours</b>		<b>67.00</b>		<b>6</b>	<b>227.00</b>	
Rate per hour		\$ 80.00	\$ 120.00	\$145.00	\$1.25	
<b>Total pay</b>		<b>\$ 5,360.00</b>	<b>\$ -</b>	<b>\$ 870.00</b>	<b>\$ 283.75</b>	<b>\$ 6,513.75</b>

James Poitevent

Employee signature

Date

  
Manager signature

11.18.19

Date

P I C

A Pipeline Inspection Company  
1705 Richardson Road  
Liberty, Texas 77575

392200

Invoice

Date:	November 28, 2019
Invoice #:	Lonestar 9
Customer ID:	CAMSTEX
Purchase Order #	None
Payment Due by:	Due upon receipt

**Bill To:**

CAMS Midstream, LLC  
919 Milam Street  
Suite 2300  
Houston, TX 77002  
713-358-9700

**Ship To (If Different):**

Description	Line Total
Time Allocation for 11/18/19 thru 11/23/19: 62 Hours (as attached)	4,960.00
Expenses for pay period 2019 (as attached)	-
Vehicle Mileage: 598 miles at \$1.25/mile	747.50
Per Diem: 5 days a \$145.00 per day	725.00
<b>RECEIVED</b>	
DEC 5 2019	
A/P DEPARTMENT	

**Special Notes and Instructions**

Charge to: 17 MH 033 Dicker Road Project  
Please issue check to P I C and mail to address below

3055000 104-358-72-00-000

Subtotal	\$	6,432.50
Sales Tax Rate	%	0.00
Sales Tax	\$	-
S&H	\$	-
Discount	\$	-
<b>Total</b>	<b>\$</b>	<b>6,432.50</b>

Make all checks payable to P I C

Thank you for your business!

Should you have any enquiries concerning this invoice, please contact James Poitevent

1705 Richardson, Liberty, TX 77575  
Tel: 713-201-6644 poitevent@att.net

*(Signature)* 12.02.19  
22: Lonestar - Dicker Road  
Relocation  
TXDOT REIMBURSABLE

# James Poitevent

## Time Card

Employee James Poitevent  
 [Street Address] Lonestar Invoice 9  
 [City, ST ZIP Code] \_\_\_\_\_  
 Week ending: 11/24/2019

Manager: James Poitevent  
 Employee phone: 713-201-6644  
 Employee e-mail: poitevent@att.net

Day	Date	Regular Hours	Overtime	Per Diem	Expense	Total
Monday	11/18/2019	10.00		1	30.00	
Tuesday	11/19/2019	10.00		1	31.00	
Wednesday	11/20/2019	11.00		1	46.00	
Thursday	11/21/2019	10.00		1	44.00	
Friday	11/22/2019	13.00		1	42.00	
Saturday	11/23/2019	8.00			405.00	Drivetime
Sunday	11/24/2019					
<b>Total hours</b>		<b>62.00</b>		<b>5</b>	<b>598.00</b>	
<b>Rate per hour</b>		\$ 80.00	\$ 120.00	\$ 145.00	\$ 1.25	
<b>Total pay</b>		\$ 4,960.00	\$ -	\$ 725.00	\$ 747.50	\$ 6,432.50

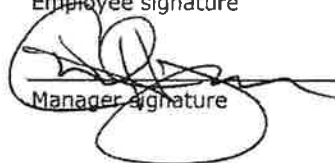
James Poitevent  
 Employee signature \_\_\_\_\_ Date \_\_\_\_\_  
 \_\_\_\_\_ Date 12.02.19  
 Manager signature \_\_\_\_\_



**CONSOLIDATED ASSET MANAGEMENT SERVICES, LLC**

919 Milam Street, Suite 2300 Houston, TX 77002-5418

**TO: Lonestar Pipeline Company, LLC**  
 c/o Frontera Energy Center  
 900 S Goodwin Road  
 Mission, TX 78572

**Attention: Ed Fuselier**  
[ed.fuselier@kindle-energy.com](mailto:ed.fuselier@kindle-energy.com)  
**Renee Bautista**  
[renee.bautista@lonestargen.com](mailto:renee.bautista@lonestargen.com)

**Invoice No.: LONPIP 20191210**  
**Date: 10-Dec-2019**  
**Due Date: 25-Dec-2019**  
 R.Wilson  
**Prepared by: 713-358-9743**

Pursuant to the terms of the Pipeline Services Agreement dated 11/1/2014 by and between Consolidated Asset Management Services, LLC ("CAMS") and Lonestar Pipeline Company, LLC (d/b/a Rio Grande Interstate Pipeline LLC) ("Lonestar"); Non-Routine fees per "Exhibit 1" to the above contract:

**Non-Routine Services:**

Brighton Group - Dicker Road Relocation ( Inv# 050819 dated 11/7/19)      **Reimbursable by TXDOT**      **34,999.50**  
 TxDOT  
 Reimbursable

**TOTAL AMOUNT DUE: \$ 34,999.50**

**Wire Instructions:**  
 Consolidated Asset Management  
 Services Texas, LLC  
 Amegy Bank  
 ABA#: 113011258  
 Account # 003771350

CO	Coding:						Amount
CAMSTEX	Acct		Subaccount				
LONPIP	1110000	104	000	00	00	0000	34,999.50
	1140000	104	000	00	00	0000	0.00
	3050000	104	354	00	00	0000	0.00
	3055000	104	354	00	00	0000	(34,999.50)

Brighton Group, LLC  
2805 Fountain Plaza Blvd., Suite A  
Edinburg, Texas 78539  
**(956) 603-2005 (o) | (956) 250-7122 (c)**



**INVOICE NO. 050819** **November 7, 2019**

**BILL TO**  
Attn: Colin Harper  
Consolidated Asset  
Management  
Services (Texas)  
LLC  
919 Milam St.  
Suite 2300  
Houston, Texas 77072

DESCRIPTION	TOTAL
Project Site Visits	\$2,960.00
Meetings/Coordination/Management Oversight	\$11,100.00
Negotiations with landowners	\$5,580.00
Closing Documents for TxDOT Reimbursements	\$5,380.00
Appraisal Services (Both Tracts)	\$5,000.00
Survey, Staking & Land Use Plan (Both Tracts)	\$4,979.50*

\*Actual Survey Services exceeded the original estimate approved on Task Order #1 due to increased site visits and multiple staking services needed for the Strike Contractors.

Best regards.

  
Joseph Palacios  
President of Brighton Group, LLC

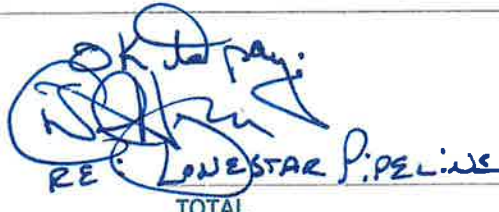
  
RE: LONESTAR PIPELINE  
TOTAL **\$34,999.50** ✓  
DICKER ROAD TxDOT RELOCATION

Thank you for your business!



**CONSOLIDATED ASSET MANAGEMENT SERVICES, LLC**

919 Milam Street, Suite 2300 Houston, TX 77002-5418

**TO: Lonestar Pipeline Company, LLC**  
 c/o Frontera Energy Center  
 900 S Goodwin Road  
 Mission, TX 78572

**Attention: Ed Fuselier**  
[ed.fuselier@kindle-energy.com](mailto:ed.fuselier@kindle-energy.com)

**Invoice No.:** LONPIP 20191230  
**Date:** 15-Jan-2020  
**Due Date:** 30-Jan-2020  
 R.Wilson  
**Prepared by:** 713-358-9743

Pursuant to the terms of the Pipeline Services Agreement dated 11/1/2014 by and between Consolidated Asset Management Services, LLC ("CAMS") and Lonestar Pipeline Company, LLC (d/b/a Rio Grande Interstate Pipeline LLC) ("Lonestar"); Non-Routine fees per "Exhibit 1" to the above contract:

**Non-Routine Services:**

**CAMS "Allocated Time for Colin Harper" related to TRRC OQ Audit**

(see attached time allocation schedule)

TRRC OQ Audit	<u>2.00</u>	
Hours:	2.00	
Rate per Hour:	250.00	500.00

**CAMS "Allocated Time for Heather Davis" related to TRRC OQ Audit**

(see attached time allocation schedule)

TRCC OQ Audit	<u>28.00</u>	
Hours:	28.00	
Rate per Hour:	85.00	2,380.00

**Other Non-Routine Services:**

CAMS Trident - Locate and Mark Lines ( Inv# 070088 dated 12/31/19)	4,448.41	
CAMS Trident - Test Station Install ( Inv# 070150 dated 12/31/19) Reimbursable by TXDOT	9,365.69	TxDOT
PIC - Inspection Services for Dicker Rd Relo (Inv# Lonestar 10 dated 12/17/19) Reimbursable by TX DOT	580.00	Reimbursable
Texas Railroad Commision - Letter of Credit Fees (Inv# BankDebit dated 1/3/20)	810.42	
UPS charges to M&H for Dicker Rd (Inv# 53R7R8519 dated 12/21/19) Reimbursable by TX DOT	19.63	
M&H Enterprises - Eng Svc (Inv# INV065282 dated 1/8/20) plus 15% markup Reimbursable by TX DOT	8,269.64	TxDOT
M&H Enterprises - Eng Svs (Inv# INV065293 dated 1/8/20) plus 15% markup	576.15	Reimbursable
M&H Enterprises - Eng Svc (Inv# INV065075 dated 12/10/19) plus 15% markup Reimbursable by TX DOT	45,522.43	
M&H Enterprises - Eng Svc (Inv# INV065088 dated 12/10/19) plus 15% markup	7,889.78	
Majic Valley Electric - December electric for rectifiers ( Inv# 290790-DEC dated 12/27/19)	32.55	
Direct Energy - December electric ( Inv# 200070040792498 dated 1/7/20)	12.12	
Direct Energy - December electric ( Inv# 200070040789102 dated 1/7/20)	12.23	
Texas Excavation Safety System - Nov message fees ( Inv# 19-21938 dated 11/30/19)	47.50	
CAMS Midstream Services, LLC - Sept - Dec Expenses	1,061.73	

**TOTAL AMOUNT DUE: \$ 81,528.28**



**Wire Instructions:**  
 Consolidated Asset Management  
 Services Texas, LLC  
 Amegy Bank  
 ABA#: 113011258  
 Account # 003771350

CO	Acct	Subaccount	Amount
CAMSTEX	1110000	104 000 00 0000	81,528.28
LONPIP	1140000	104 000 00 0000	0.00
	3050000	104 354 00 0000	(2,880.00)
	3055000	104 354 00 0000	(78,648.28)



Invoice Date December 31, 2019  
 Invoice Number 070150  
 PO Number  
 Due Date January 30, 2020  
 Payment Terms Net 30 Days

Page 1 of 1

Work Performed for:

CONSOLIDATED ASSET MGMT SERV (TX) LLC  
 ATTN: GERRY PARKER  
 919 MILAM STREET SUITE 2300  
 HOUSTON, TX 77002

2019-1511 Test Station Install 10th/Dicker Crossing  
 Line Purge with Nitrogen & Quarterly Survey of Encroachments

Description	Qty	Rate	Amount
<u>Tuesday, December 3, 2019</u> Decemeber 3,16-19, 2019 Technicians, Truck, Equipment & Per Diem	5.00	1,350.00	6,750.00
<u>Tuesday, December 17, 2019</u> Chemical Analysis	1.00	1,610.00	1,610.00
Nitrogen Blanket, 1 Man Crew, Supervisor & Truck	1.00	1,005.69	1,005.69

*[Handwritten Signature]* 1.09.20  
 P.S.: *[Handwritten]* - Dicker

**DOT REIMBURSEABLE \$9,365.69**

**Invoice Total**

CAMS Trident Project#: CAMSTX-19-114

**Remit Payment To:** CAMS Trident, LLC  
 919 Milam Street  
 Suite 2300  
 Houston, TX 77002  
 Phone: 7133589796

**Wire Instructions:**

Receiving Bank: Amegy Bank, N.A  
 Beneficiary: CAMS Trident, LLC  
 Account: 0054030273  
 ABA: 113011258

393134

# Invoice

## P I C

A Pipeline Inspection Company  
1705 Richardson Road  
Liberty, Texas 77575

Date:	December 17, 2019
Invoice #:	Lonestar <b>10</b>
Customer ID:	CAMSTEX
Purchase Order #:	None
Payment Due by:	Due upon receipt

### Bill To:

CAMS Midstream, LLC  
919 Milam Street  
Suite 2300  
Houston, TX 77002  
713-358-9700

### Ship To (If Different):

Description	Line Total
Time Allocation for 10/27/19 - 11/17/19:	
Expenses for pay period 2019 (as attached)	-
Vehicle Mileage:	
Per Diem: 4 days at \$145/day	580.00

**RECEIVED**  
DEC 17 2019  
A/P DEPARTMENT

### Special Notes and Instructions

Charge to: 17MH033 Dicker Road Project  
Please make check payable to P I C and mail to address below  
  
305500 104-354-72-00-000

Subtotal	\$	580.00
Sales Tax Rate	%	0.00
Sales Tax	\$	-
S&H	\$	-
Discount	\$	-
<b>Total</b>	<b>\$</b>	<b>580.00</b>

Make all checks payable to P I C

**Thank you for your business!**

Should you have any enquiries concerning this invoice, please contact James Poitevent

1705 Richardson, Liberty, TX 77575  
Tel: 713-201-6644 poitevent@att.net

*[Signature]*  
P.E.: Lonestar Pipeline  
Dicker Rd  
Relocation  
\* DoT Reimbursable

# James Poitevent

## Time Card

Employee James Poitevent  
 [Street Address] Lonestar INV 10  
 [City, ST ZIP Code] \_\_\_\_\_  
 Week ending: 10/27/19 - 11/17/19

Manager: James Poitevent  
 Employee phone: 713-201-6644  
 Employee e-mail: poitevent@att.net

Day	Date	Regular Hours	Overtime	Per Diem	Expense	Total
Sunday	10/27/2019			1		
Sunday	11/3/2019			1		
Sunday	11/10/2019			1		
Sunday	11/17/2019			1		
<b>Total hours</b>				<b>4</b>		
<b>Rate per hour</b>		\$ 80.00	\$ 120.00	\$145.00	\$1.25	
<b>Total pay</b>		\$ -	\$ -	\$ 580.00	\$ -	\$ 580.00

James Poitevent  
 Employee signature

12/17/19  
 Date

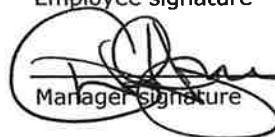
  
 Manager signature

Date



393674

**Delivery Service Invoice**

Invoice Date **December 21, 2019**  
Invoice Number **000053R7R8519**  
Shipper Number **53R7R8**  
Control ID **08V3**  
Page 1 of 9

0312A000053R7R84

**Sign up for electronic billing today!**  
Visit [ups.com/billing](http://ups.com/billing)

For questions about your invoice, call:  
(800) 811-1648  
Monday - Friday  
8:00 a.m. - 9:00 p.m. E.T.

**CONSOLIDATED ASSET MANAGEMENT  
RAMONA WATKINS  
919 MILAM ST RM 2300  
HOUSTON, TX 77002-5418**

or write:  
UPS  
P.O. Box 7247-0244  
Philadelphia, PA 19170-0001

***Incentive Savings***

Total incentive savings this period **\$ 508.79**

Your amount due this period includes these savings.

See incentive summary section for details.

***Account Status Summary  
Weekly Payment Plan***

Amount Due This Period **\$ 665.20**

Amount Outstanding (prior invoices) **\$ 253.88**

Total Amount Outstanding **\$ 919.08**

Please include the Return Portion of each outstanding invoice with your payment. See Account Status for details.

***Rate Change Information***

Effective December 29, 2019, rates for UPS® Ground, UPS Air and International services, as well as UPS Air Freight rates within and between the U.S., Canada, and Puerto Rico, will increase. For additional changes and information, and to review the new rates and other charges, visit [www.rates.ups.com](http://www.rates.ups.com).

**Thank you for using UPS.**

**Summary of Charges**

Page		Charge
	<b>Outbound</b>	
4	UPS CampusShip	\$ 631.21
7	Adjustments & Other Charges	\$ 33.99
8	Service Charges	\$ 0.00
<b>Amount due this period</b>		<b>\$ 665.20</b>

UPS payment terms require payment of this invoice by December 30, 2019.

Payments received late are subject to a late payment fee of 6% of the Amount Due This Period. (see Tariff/Terms and Conditions of Service at [ups.com](http://ups.com) for details)

Note: This invoice may contain a fuel surcharge as described at [ups.com](http://ups.com). For more information, please visit [ups.com](http://ups.com).

Please tear off and send with your payment in the enclosed envelope. Do not use staples or paper clips.



**Return Portion**

**CONSOLIDATED ASSET MANAGEMENT  
RAMONA WATKINS  
919 MILAM ST RM 2300  
HOUSTON, TX 77002-5418**

Invoice Date **December 21, 2019**  
Invoice Number **000053R7R8519**  
Shipper Number **53R7R8**

Amount due this period **\$ 665.20**

Amount enclosed

If this billing address is incorrect, mark an "X" in this box and make the appropriate changes above.

**UPS  
P.O. BOX 7247-0244  
PHILADELPHIA, PA 19170-0001**

53R7R8 9 122119 0312 1 00000665200 1



# Delivery Service Invoice

Invoice Date **December 21, 2019**

Invoice Number **000053R7R8519**

Shipper Number **53R7R8**

## Outbound UPS CampusShip

Pickup Date	Tracking Number	Service	ZIP Code	Zone	Weight	Published Charge	Incentive Credit	Billed Charge
12/16	1Z53R7R80297746754	2nd Day Air Commercial Letter	93308	207	Letter	28.86	-13.28	15.58
		Fuel Surcharge				2.02	-0.93	1.09
		<b>Total</b>				30.88	-14.21	16.67
	<b>1st ref:</b> ANZGT							
	<b>UserID:</b> al.hale							
	<b>Sender :</b> Alicia Hale CAMS 919 MILAM ST HOUSTON TX 77002							
		<b>2nd ref:</b> HCURRYCC						
		<b>Receiver:</b> ANZGT Field Services LLC 34759 Lencioni Ave BAKERSFIELD CA 93308						
12/18	1Z53R7R81597940395	Next Day Air Early Commercial Letter	77975	102	Letter	24.64		24.64
		Delivery Area Surcharge - Extended				2.95		2.95
		Early Surcharge				30.00		30.00
		Fuel Surcharge				4.03		4.03
		<b>Total</b>				61.62		61.62
	<b>1st ref:</b> Lavaca							
	<b>UserID:</b> al.hale							
	<b>Sender :</b> Alicia Hale CAMS 919 MILAM ST HOUSTON TX 77002							
		<b>2nd ref:</b> CCX9						
		<b>Receiver:</b> Brady Anderson Lavaca Midstream 526 South Lavaca St MOULTON TX 77975						
	<b>Total for UserID:</b> al.hale					92.50	-14.21	78.29
12/19	1Z53R7R8NT95787023	Next Day Air Commercial Letter	77070	102	6	41.70	-23.35	18.35
		Customer Weight			3			
		Fuel Surcharge				2.92	-1.64	1.28
		Customer Entered Dimensions = 18 x 13 x 3 in						
		<b>Total</b>				44.62	-24.99	19.63
	<b>1st ref:</b> LSPL - Dicker Road							
	<b>Sender :</b> Heather Davis CAMS 919 MILAM ST HOUSTON TX 77002							
		<b>UserID:</b> hm.davis						
		<b>Receiver:</b> Kaela Linscombe M&H 19450 Hwy 249 HOUSTON TX 77070						
	<b>Message Codes:</b> r							
	<b>Total for UserID:</b> hm.davis					44.62	-24.99	19.63
12/17	1Z53R7R80190585380	Next Day Air Commercial Letter	06051	107	Letter	43.72	-24.48	19.24
		Fuel Surcharge				3.06	-1.71	1.35
		<b>Total</b>				46.78	-26.19	20.59
	<b>1st ref:</b> Waterside Power							
	<b>UserID:</b> jos.nobile							
	<b>Sender :</b> Joe Nobile CAMS 919 MILAM ST HOUSTON TX 77002							
		<b>2nd ref:</b> OCC						
		<b>Receiver:</b> Joseph Rosenthal Office of Consumer Council 10 Franklin Square NEW BRITAIN CT 06051						
12/17	1Z53R7R80190609390	Next Day Air Commercial Letter	06051	107	Letter	43.72	-24.48	19.24
		Fuel Surcharge				3.06	-1.71	1.35
		<b>Total</b>				46.78	-26.19	20.59
	<b>1st ref:</b> Waterside Power							
	<b>UserID:</b> jos.nobile							
	<b>Sender :</b> Joe Nobile CAMS 919 MILAM ST HOUSTON TX 77002							
		<b>2nd ref:</b> PURA						
		<b>Receiver:</b> Jeffrey Guadiosi Public Utilities Regulatory Au 10 Franklin Square NEW BRITAIN CT 06051						

4987000	104 - 214 - 72 - 00 - 0000	16.67
4987000	104 - 221 - 72 - 00 - 0000	117.52
4987000	104 - 231 - 72 - 00 - 0000	34.61
4987000	104 - 267 - 72 - 00 - 0000	99.63
3055000	104 - 354 - 72 - 00 - 0000	19.63
4987000	104 - 374 - 72 - 00 - 0000	17.77
4987000	104 - 375 - 72 - 00 - 0000	17.75
4987000	104 - 451 - 72 - 00 - 0000	11.63
4987000	104 - 921 - 72 - 00 - 0000	35.26
4987000	104 - 964 - 72 - 00 - 0000	86.15
4987000	104 - 000 - 72 - 00 - 145D	38.68
4987000	104 - 000 - 72 - 00 - 171B	18.65
4987000	104 - 000 - 72 - 00 - 176B	29.81
4987000	104 - <sup>163</sup> 000 - 72 - 00 - <del>208B</del>	61.62
6407000	104 - 000 - 00 - 00 - 0000	28.43
6407000	104 - 110 - 00 - 00 - 0000	31.39

665.20



M&H Enterprises Inc.  
 dba M&H Energy Services  
 19450 HWY 249, Suite 600  
 Houston, TX 77070  
 (281) 664-7222

# INVOICE

**Bill To: CAMS Midstream**

Colin Harper  
 919 Milam Street  
 Suite 2300  
 Houston, Texas 77002

Invoice Date: 1/8/2020  
 Invoice No: INV065282  
 Terms:

For services rendered for the calendar month ending **December 31, 2019**

**M&H Project No: 17MH033 Dicker Road Hidalgo County**

Inquiries can be sent to charper@camstex.com

**PROFESSIONAL SERVICES**

	Rate	Qty	Amount
Design Supervisor	176.00	9.50 ✓	\$ 1,672.00
Engineering Consultant 4	101.00	3.50 ✓	\$ 353.50
Project Controls Coordinator 2	101.00	4.00 ✓	\$ 404.00
Purchasing Manager	165.00	3.50 ✓	\$ 577.50
Senior Lead Eng Consultant	156.00	4.00 ✓	\$ 624.00
Senior Project Director	200.00	8.50 ✓	\$ 1,700.00
Specialist Engineering Consult	169.00	1.00 ✓	\$ 169.00
		34.00	\$ 5,500.00

**EXPENSES**

\$ 1,690.99 ✓

Total Invoice Amount: **\$ 7,190.99**

Project Manager: R. Perego

*Handwritten signature and notes:*  
 1/10/20  
 R.E. Lancaster  
 Dicker Road (TXDOT)

Task ID	Date	User ID	Employee Class	Billing Description	Pay Code	Qty	Bill Rate	Cost Amount	Bill Amount
---------	------	---------	----------------	---------------------	----------	-----	-----------	-------------	-------------

**M&H Project No: 17MH033 Dicker Road Hidalgo County**

**Professional Services**

<i>Con</i>	ENG-PC-1	12/2/2019	peregor	Senior Project Director	Strike actual cost estimate, leftover materials	EXEMPT	2.00	200.00	400.00
		12/3/2019	peregor	Senior Project Director	Conference call, Strike actual cost estimate	EXEMPT	3.00	200.00	600.00
		12/4/2019	peregor	Senior Project Director	Issue Strike actual cost estimate, project management	EXEMPT	1.50	200.00	300.00
		12/19/2019	peregor	Senior Project Director	TIC estimate, job books	EXEMPT	2.00	200.00	400.00
				<b>Project Coordination - Management</b>	<b>Task Totals</b>	<b>8.50</b>			<b>\$ 1,700.00</b>
<i>K. Arana</i>	ENG-PC-2	12/3/2019	linscombek	Project Controls Coordinator 2	Project Controls, Final Conf Call, PAR/Cost Report	HOURLY	1.50	101.00	151.50
		12/4/2019	linscombek	Project Controls Coordinator 2	Project Controls, Trans 0009, PM2017	HOURLY	1.50	101.00	151.50
		12/18/2019	linscombek	Project Controls Coordinator 2	Project Controls, Job Books Discussion/Edit	HOURLY	1.00	101.00	101.00
				<b>Project Coordination - Controls</b>	<b>Task Totals</b>	<b>4.00</b>			<b>\$ 404.00</b>
<i>Gus / Stacy</i>	ENG-PC-3	12/17/2019	arnesonp	Specialist Engineering Consult	Support on TXDOT close out and metal sampling.	EXEMPT	1.00	169.00	169.00
		12/2/2019	landryjer	Senior Lead Eng Consultant	Site Support Close-Out	HOURLY	3.00	156.00	468.00
		12/3/2019	landryjer	Senior Lead Eng Consultant	Track information from survey	HOURLY	1.00	156.00	156.00
		12/16/2019	ramirezg	Engineering Consultant 4	Nitrogen Blanket Engineering Support	EXEMPT	1.50	101.00	151.50
		12/23/2019	smiths	Purchasing Manager	Reviewing invoices and correspondence with client/ suppliers	EXEMPT	2.00	165.00	330.00
				<b>Project Coordination - General</b>	<b>Task Totals</b>	<b>8.50</b>			<b>\$ 1,274.50</b>
<i>Gus / Stacy</i>	ENG-PC-5	12/3/2019	ramirezg	Engineering Consultant 4	Project Update Meeting	EXEMPT	0.50	101.00	50.50
		12/3/2019	smiths	Purchasing Manager	Weekly project team call to review close out items	EXEMPT	0.50	165.00	82.50
		12/4/2019	smiths	Purchasing Manager	Meeting with Apex on invoicing issues and credit owed	EXEMPT	1.00	165.00	165.00
				<b>Project Coordination - Meetings</b>	<b>Task Totals</b>	<b>2.00</b>			<b>\$ 298.00</b>

Task ID	Date	User ID	Employee Class	Billing Description	Pay Code	Qty	Bill Rate	Cost Amount	Bill Amount
<b>PL-AS</b> <i>Gar</i>	12/18/2019	ramirezg	Engineering Consultant 4	Alignment Sheet Review	EXEMPT	0.50	101.00		50.50
				<b>Alignment Sheets</b>	<b>Task Totals</b>	<b>0.50</b>			<b>\$ 50.50</b>
<b>PL-AS-D</b> <i>JASON</i>	12/17/2019	smithj	Design Supervisor	As-Built Alignment Sheet	HOURLY	2.00	176.00		352.00
	12/18/2019	smithj	Design Supervisor	As-Built Alignment Sheet	HOURLY	6.50	176.00		1,144.00
	12/19/2019	smithj	Design Supervisor	Issue As-Built Drawing Package	HOURLY	1.00	176.00		176.00
				<b>Alignment Sheets - AutoCAD Drawing</b>	<b>Task Totals</b>	<b>9.50</b>			<b>\$ 1,672.00</b>
<b>PL-SC</b> <i>Gar</i>	12/19/2019	ramirezg	Engineering Consultant 4	As-Built Weld Map Check	EXEMPT	1.00	101.00		101.00
				<b>Pipeline Schematic</b>	<b>Task Totals</b>	<b>1.00</b>			<b>\$ 101.00</b>
<b>Professional Services Total</b>						<b>34.00</b>			<b>\$ 5,500.00</b>

**Expenses**

<b>EXP - MARK UP</b> <i>JERRY</i>	12/11/2019	landryjer	Senior Lead Eng Consultant	Truck rental	EXP	1.00	878.710	798.83	878.71
	12/2/2019	moutonj	Project Controls Coordinator 2	MC - Hilton Garden Inn - Jerry Landry's stay in McAllen, texas	EXP	1.00	698.280	634.80	698.28
				<b>General Project Expense</b>	<b>Task Totals</b>	<b>2.00</b>		1,433.63	<b>\$ 1,576.99</b>
<b>EXP - SOFTWARE</b>	12/21/2019	Software	Software Charges	Software charge - CAD	EXP	9.50	12.000	114.00	114.00
				<b>Software - 12 CAD / 25 SACS</b>	<b>Task Totals</b>	<b>9.50</b>		114.00	<b>\$ 114.00</b>
<b>Expenses Total</b>						<b>11.50</b>			<b>\$ 1,690.99</b>

Total Invoice Amount: \$ 7,190.99



M&H Enterprises Inc.  
 dba M&H Energy Services  
 19450 HWY 249, Suite 600  
 Houston, TX 77070  
 (281) 664-7222

**INVOICE**  
 393757

Invoice Date: 12/10/2019  
 Invoice No: INV065075  
 Terms:

**Bill To: CAMS Midstream**

Colin Harper  
 919 Milam Street  
 Suite 2300  
 Houston, Texas 77002

For services rendered for the calendar month ending **November 30, 2019**

**M&H Project No: 17MH033 Dicker Road Hidalgo County**

Inquiries can be sent to charper@camstex.com

**PROFESSIONAL SERVICES**

	Rate	Qty	Amount
Design Supervisor	176.00	8.50	\$ 1,496.00
Engineering Consultant 4	101.00	86.00	\$ 8,686.00
Project Controls Coordinator 2	101.00	8.00	\$ 808.00
Project Controls Coordinator 2	136.35	1.00	\$ 136.35
Purchasing Manager	165.00	12.00	\$ 1,980.00
Senior Lead Eng Consultant	156.00	84.00	\$ 13,104.00
Senior Project Director	200.00	24.00	\$ 4,800.00
Specialist Engineering Consult	169.00	4.50	\$ 760.50
Sr Specialist Eng Consultant	185.00	27.50	\$ 5,087.50
		255.50	\$ 36,858.35

**EXPENSES**

\$ 2,726.37

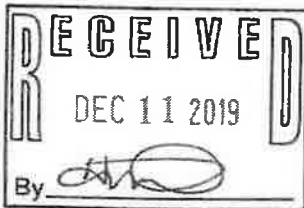

3055000 104-354-72-00-000

Total Invoice Amount: **\$ 39,584.72**

RECEIVED  
 DEC 27 2019  
 A/P DEPARTMENT

12.12.19  
 R2: Lonesta  
 Dicker Road Relocation  
 TX DOT Project

Project Manager: R. Perego

- BILLABLE / REIMBURSABLE -

Task ID	Date	User ID	Employee Class	Billing Description	Pay Code	Qty	Bill Rate	Cost Amount	Bill Amount
---------	------	---------	----------------	---------------------	----------	-----	-----------	-------------	-------------

**M&H Project No: 17MH033 Dicker Road Hidalgo County**

**Professional Services**

<b>ENG-PC-1</b> ✓ <i>Row 9.</i>	11/12/2019	pergor	Senior Project Director	2 conference calls, project management	EXEMPT	2.00	200.00		400.00
	11/14/2019	pergor	Senior Project Director	Conference call, project management	EXEMPT	1.50	200.00		300.00
	11/15/2019	pergor	Senior Project Director	Conference call	EXEMPT	0.50	200.00		100.00
	11/18/2019	pergor	Senior Project Director	Review HDD failure, planning	EXEMPT	5.50	200.00		1,100.00
	11/19/2019	pergor	Senior Project Director	2 conference calls, contractor call, planning	EXEMPT	2.50	200.00		500.00
	11/20/2019	pergor	Senior Project Director	Conference call, arrange/meet with inspector	EXEMPT	4.00	200.00		800.00
	11/22/2019	pergor	Senior Project Director	Conference call	EXEMPT	0.50	200.00		100.00
<b>Project Coordination - Management</b>						<b>Task Totals</b>	<b>16.50</b>		<b>\$ 3,300.00</b> ✓
<b>ENG-PC-2</b> ✓ <i>Kazal.</i>	11/1/2019	linscombek	Project Controls Coordinator 2	Project Controls, Trans 0008	HOUROT	1.00	136.35		136.35
	11/5/2019	linscombek	Project Controls Coordinator 2	Project Controls, Weekly Call, Cost Report	HOURLY	1.50	101.00		151.50
	11/7/2019	linscombek	Project Controls Coordinator 2	Project Controls Coordination	HOURLY	0.50	101.00		50.50
	11/12/2019	linscombek	Project Controls Coordinator 2	Project Controls, Weekly Call	HOURLY	0.50	101.00		50.50
	11/19/2019	linscombek	Project Controls Coordinator 2	Project Controls, Cost Report, Pipe Damage Discussion	HOURLY	1.00	101.00		101.00
	11/20/2019	linscombek	Project Controls Coordinator 2	Project Controls, Add Jerry to project, Meeting w/ Jerry	HOURLY	1.00	101.00		101.00
	11/25/2019	linscombek	Project Controls Coordinator 2	Project Controls, Cost Report/PAR	HOURLY	1.00	101.00		101.00
	11/20/2019	moutonj	Project Controls Coordinator 2	Reservations for Jerry Landry (Air, hotel and car rental)	HOURLY	2.50	101.00		252.50
<b>Project Coordination - Controls</b>						<b>Task Totals</b>	<b>9.00</b>		<b>\$ 944.35</b> ✓
<b>ENG-PC-3</b> ✓ <i>P.A.</i>	11/16/2019	arnesonp	Specialist Engineering Consult	HDD failure support and coordination with Gustavo and Mark	EXEMPT	1.50	169.00		253.50
	11/17/2019	arnesonp	Specialist Engineering Consult	HDD failure coordination	EXEMPT	0.50	169.00		84.50

Task ID	Date	User ID	Employee Class	Billing Description	Pay Code	Qty	Bill Rate	Cost Amount	Bill Amount
ENG-PC-3	11/18/2019	arnesonp	Specialist Engineering Consult	Root cause failure review with Mark Gerding	EXEMPT	1.00	169.00		169.00
	11/19/2019	arnesonp	Specialist Engineering Consult	HDD ream issue review and coordination on onsite inspection	EXEMPT	1.50	169.00		253.50
	11/1/2019	gerdingm	Sr Specialist Eng Consultant	project support for field inspector	EXEMPT	2.00	185.00		370.00
	11/4/2019	gerdingm	Sr Specialist Eng Consultant	project support	EXEMPT	1.00	185.00		185.00
	11/5/2019	gerdingm	Sr Specialist Eng Consultant	project support	EXEMPT	1.00	185.00		185.00
	11/6/2019	gerdingm	Sr Specialist Eng Consultant	project support	EXEMPT	0.50	185.00		92.50
	11/11/2019	gerdingm	Sr Specialist Eng Consultant	morning mtg with field;	EXEMPT	0.50	185.00		92.50
	11/12/2019	gerdingm	Sr Specialist Eng Consultant	morning mtg with field; estimate hydrotest volume	EXEMPT	1.00	185.00		185.00
	11/13/2019	gerdingm	Sr Specialist Eng Consultant	morning mtg with field;	EXEMPT	0.50	185.00		92.50
	11/14/2019	gerdingm	Sr Specialist Eng Consultant	morning confernce call with field; foillow up & locate surveyor; coodinate plan map correction; OQ's	EXEMPT	5.50	185.00		1,017.50
	11/16/2019	gerdingm	Sr Specialist Eng Consultant	conference calls, HDD review	EXEMPT	2.00	185.00		370.00
	11/18/2019	gerdingm	Sr Specialist Eng Consultant	project support	EXEMPT	1.00	185.00		185.00
	11/19/2019	gerdingm	Sr Specialist Eng Consultant	project support	EXEMPT	1.00	185.00		185.00
	11/20/2019	gerdingm	Sr Specialist Eng Consultant	project support & meeting with Jerry Landry	EXEMPT	3.00	185.00		555.00
	11/21/2019	gerdingm	Sr Specialist Eng Consultant	project support; discussion with ricky lay regarding test station	EXEMPT	1.00	185.00		185.00
	11/22/2019	gerdingm	Sr Specialist Eng Consultant	confernce call & project support	EXEMPT	2.00	185.00		370.00
	11/23/2019	gerdingm	Sr Specialist Eng Consultant	confernce call & project support; forward survey data to Jerry for Strike as-built	EXEMPT	1.00	185.00		185.00
	11/25/2019	gerdingm	Sr Specialist Eng Consultant	project support	EXEMPT	1.00	185.00		185.00
	11/26/2019	gerdingm	Sr Specialist Eng Consultant	project support	EXEMPT	1.00	185.00		185.00
	11/27/2019	gerdingm	Sr Specialist Eng Consultant	project support	EXEMPT	1.00	185.00		185.00
	11/1/2019	ramirezg	Engineering Consultant 4	Site Visit Coordination	EXEMPT	0.50	101.00		50.50

Task ID	Date	User ID	Employee Class	Billing Description	Pay Code	Qty	Bill Rate	Cost Amount	Bill Amount
<b>ENG-PC-3</b> <i>Strike</i>	11/17/2019	ramirezg	Engineering Consultant 4	Engineering Field Report	EXEMPT	4.00	101.00		404.00
	11/7/2019	smiths	Purchasing Manager	Vendor correspondence	EXEMPT	0.25	165.00		41.25
	11/11/2019	smiths	Purchasing Manager	Vendor/ subcontractor correspondence with MEG on payment status and final asbestos report	EXEMPT	1.00	165.00		165.00
	11/12/2019	smiths	Purchasing Manager	Vendor/ subcontractor correspondence with MEG on payment status and final asbestos report	EXEMPT	1.00	165.00		165.00
	11/14/2019	smiths	Purchasing Manager	Apex invoice review, vendor correspondence on banking info etc	EXEMPT	1.50	165.00		247.50
	11/15/2019	smiths	Purchasing Manager	Vendor correspondence	EXEMPT	0.50	165.00		82.50
	11/18/2019	smiths	Purchasing Manager	Sourcing replacement pipe for project, Apex invoice review and vendor correspondence	EXEMPT	2.00	165.00		330.00
	11/19/2019	smiths	Purchasing Manager	Vendor correspondence on replacement pipe, accounting info requests for all other subs	EXEMPT	1.00	165.00		165.00
	11/25/2019	smiths	Purchasing Manager	Vendor correspondence, Apex and C4	EXEMPT	0.50	165.00		82.50
	11/26/2019	smiths	Purchasing Manager	APEX/MEG correspondence, MTR's updating and send to Sergio @ Frontera, Shawcor on invoicing instruction, asbestos report submitted to Strike for pipe disposal	EXEMPT	2.00	165.00		330.00
<b>Project Coordination - General</b>					<b>Task Totals</b>	<b>44.75</b>			<b>\$ 7,633.75</b> ✓
<b>ENG-PC-4</b> <i>Gen</i>	11/4/2019	ramirezg	Engineering Consultant 4	Engineering Support	EXEMPT	1.00	101.00		101.00
	11/5/2019	ramirezg	Engineering Consultant 4	Engineering Support	EXEMPT	1.00	101.00		101.00
	11/13/2019	ramirezg	Engineering Consultant 4	Travel Time and Site Engineering Support	EXEMPT	8.00	101.00		808.00
	11/14/2019	ramirezg	Engineering Consultant 4	Field Engineering Support	EXEMPT	9.00	101.00		909.00
	11/15/2019	ramirezg	Engineering Consultant 4	Field Engineering Support	EXEMPT	10.00	101.00		1,010.00
	11/16/2019	ramirezg	Engineering Consultant 4	Engineering Field Support	EXEMPT	8.00	101.00		808.00
	11/18/2019	ramirezg	Engineering Consultant 4	Engineering Field Support	EXEMPT	8.00	101.00		808.00

Invoice No: **INV065075**

Task ID	Date	User ID	Employee Class	Billing Description	Pay Code	Qty	Bill Rate	Cost Amount	Bill Amount
ENG-PC-4	11/19/2019	ramirezg	Engineering Consultant 4	Engineering Field Support	EXEMPT	7.00	101.00		707.00
<i>Gus</i>	11/20/2019	ramirezg	Engineering Consultant 4	Engineering Field Support	EXEMPT	9.50	101.00		959.50
	11/21/2019	ramirezg	Engineering Consultant 4	Engineering Field Support	EXEMPT	9.00	101.00		909.00
	11/22/2019	ramirezg	Engineering Consultant 4	Engineering Field Support and Travel Time	EXEMPT	11.00	101.00		1,111.00
				<b>Project Coordination - Site Visit</b>	<b>Task Totals</b>	<b>81.50</b>			<b>\$ 8,231.50</b> ✓
ENG-PC-5	11/12/2019	gerdingm	Sr Specialist Eng Consultant	weekly conference call with Lone Star	EXEMPT	0.50	185.00		92.50
	11/21/2019	gerdingm	Sr Specialist Eng Consultant	weekly project call	EXEMPT	1.00	185.00		185.00
<i>MAR 22 Rox JERRY SHERY</i>	11/20/2019	landryjer	Senior Lead Eng Consultant	Pre-mobilization meeting - Houston Office	HOURLY	3.00	156.00		468.00
	11/4/2019	peregorg	Senior Project Director	Conference call, project management	EXEMPT	1.00	200.00		200.00
	11/5/2019	peregorg	Senior Project Director	Conference call, project management	EXEMPT	1.00	200.00		200.00
	11/6/2019	peregorg	Senior Project Director	Conference call, project management	EXEMPT	1.00	200.00		200.00
	11/7/2019	peregorg	Senior Project Director	Conference call, project management	EXEMPT	1.00	200.00		200.00
	11/11/2019	peregorg	Senior Project Director	Conference call	EXEMPT	0.50	200.00		100.00
	11/13/2019	peregorg	Senior Project Director	Conference call	EXEMPT	0.50	200.00		100.00
	11/21/2019	peregorg	Senior Project Director	Conference call, project management	EXEMPT	2.50	200.00		500.00
	11/5/2019	smiths	Purchasing Manager	Weekly project status meeting	EXEMPT	0.50	165.00		82.50
	11/12/2019	smiths	Purchasing Manager	Weekly team meeting	EXEMPT	0.50	165.00		82.50
	11/18/2019	smiths	Purchasing Manager	Call with project team on HDD issues and pipe damage, Engineering team meeting	EXEMPT	0.75	165.00		123.75
	11/19/2019	smiths	Purchasing Manager	Weekly team meeting	EXEMPT	0.50	165.00		82.50
				<b>Project Coordination - Meetings</b>	<b>Task Totals</b>	<b>14.25</b>			<b>\$ 2,616.75</b> ✓
ENG-PC-6	11/21/2019	landryjer	Senior Lead Eng Consultant	travel to McAllen	HOURLY	9.00	156.00		1,404.00

*JERRY*

Task ID	Date	User ID	Employee Class	Billing Description	Pay Code	Qty	Bill Rate	Cost Amount	Bill Amount
ENG-PC-6	11/22/2019	landryjer	Senior Lead Eng Consultant	Onsite Support	HOURLY	7.00	156.00		1,092.00
	11/22/2019	landryjer	Senior Lead Eng Consultant	Onsite representative	HOURLY	8.00	156.00		1,248.00
	11/23/2019	landryjer	Senior Lead Eng Consultant	Onsite Support	HOURLY	8.00	156.00		1,248.00
	11/23/2019	landryjer	Senior Lead Eng Consultant	Onsite Support	HOURLY	2.00	156.00		312.00
	11/24/2019	landryjer	Senior Lead Eng Consultant	Oversee Hydrotest	HOURLY	8.00	156.00		1,248.00
	11/24/2019	landryjer	Senior Lead Eng Consultant	Oversee hydrotest	HOURLY	4.00	156.00		624.00
	11/25/2019	landryjer	Senior Lead Eng Consultant	onsite support	HOURLY	11.00	156.00		1,716.00
	11/26/2019	landryjer	Senior Lead Eng Consultant	Onsite	HOURLY	10.00	156.00		1,560.00
	11/27/2019	landryjer	Senior Lead Eng Consultant	Onsite support and travel	HOURLY	7.00	156.00		1,092.00
	11/27/2019	landryjer	Senior Lead Eng Consultant	onsite support and travel	HOUROT	7.00	156.00		1,092.00
<b>Project Coordination - Onsite Support</b>					<b>Task Totals</b>	<b>81.00</b>			<b>\$ 12,636.00</b> ✓
PL-RC-D	11/14/2019	smithj	Design Supervisor	Coordinate Existing Pipeline and Proposed HDD Entry Locations	HOURLY	5.50	176.00		968.00
	11/15/2019	smithj	Design Supervisor	Adjust Pipeline HDD Crossing Exhibit for New Survey	HOURLY	3.00	176.00		528.00
	<b>Road Crossing Exhibits - AutoCAD Drawing</b>					<b>Task Totals</b>	<b>8.50</b>		
<b>Professional Services Total</b>						<b>255.50</b>			<b>\$ 36,858.35</b>

Expenses

EXP - MARK UP <i>J2009</i>	11/21/2019	landryjer	Senior Lead Eng Consultant	Meals	EXP	1.00	11.550	10.50	11.55
	11/21/2019	landryjer	Senior Lead Eng Consultant	Meals	EXP	1.00	24.400	22.18	24.40
	11/24/2019	landryjer	Senior Lead Eng Consultant	Meals	EXP	1.00	35.550	32.32	35.55
	11/24/2019	landryjer	Senior Lead Eng Consultant	Meals	EXP	1.00	27.790	25.26	27.79
	11/25/2019	landryjer	Senior Lead Eng Consultant	Meals	EXP	1.00	8.310	6.86	8.31

Task ID	Date	User ID	Employee Class	Billing Description	Pay Code	Qty	Bill Rate	Cost Amount	Bill Amount
<b>EXP - MARK UP</b>	11/25/2019	landryjer	Senior Lead Eng Consultant	Meals	EXP	1.00	20.990	19.08	20.99
	11/26/2019	landryjer	Senior Lead Eng Consultant	Meals	EXP	1.00	9.040	8.22	9.04
	11/26/2019	landryjer	Senior Lead Eng Consultant	Meals	EXP	1.00	24.840	22.58	24.84
	11/27/2019	landryjer	Senior Lead Eng Consultant	Meals	EXP	1.00	7.830	7.12	7.83
	11/27/2019	landryjer	Senior Lead Eng Consultant	Fuel for rental truck	EXP	1.00	47.480	43.16	47.48
	11/29/2019	landryjer	Senior Lead Eng Consultant	Replacement fuel for rental truck	EXP	1.00	46.900	42.64	46.90
	11/29/2019	landryjer	Senior Lead Eng Consultant	Meals	EXP	1.00	23.850	21.68	23.85
	11/21/2019	moutonj	Project Controls Coordinator 2	MC - 11/20/19 - United Airlines Jerry Landry trip to the site in McAllen, Texas	EXP	1.00	449.860	408.96	449.86
	11/21/2019	peregor	Senior Project Director	CASH - 11/20 - PF Chang's - Meal (Perego, Gerding, 2 Landry)	EXP	1.00	108.310	98.46	108.31
	11/13/2019	ramirezg	Engineering Consultant 4	MC - 11/13/19 - Whataburger - Lunch Gustavo	EXP	1.00	9.810	8.92	9.81
11/14/2019	ramirezg	Engineering Consultant 4	MC - 11/14/19 - Popeyes - Lunch Gustavo and James	EXP	1.00	21.520	19.56	21.52	
11/14/2019	ramirezg	Engineering Consultant 4	MC - 11/14/19 - Whataburger - Lunch Gustavo	EXP	1.00	9.690	8.81	9.69	
11/16/2019	ramirezg	Engineering Consultant 4	MC - 11/16/19 - Popeyes - Lunch Gustavo	EXP	1.00	8.800	8.00	8.80	
11/16/2019	ramirezg	Engineering Consultant 4	MC - 11/16/19 - Stripes - Food Gustavo	EXP	1.00	6.600	6.00	6.60	
11/19/2019	ramirezg	Engineering Consultant 4	MC - 11/19/19 - El Tigre #13 - Food Gustavo	EXP	1.00	4.740	4.31	4.74	
11/19/2019	ramirezg	Engineering Consultant 4	MC - 11/19/19 - El Pastor Grill - Lunch Gustavo and James	EXP	1.00	51.850	47.14	51.85	
11/20/2019	ramirezg	Engineering Consultant 4	MC - 11/19/19 - Popeye's - Diner Gustavo	EXP	1.00	8.800	8.00	8.80	
11/21/2019	ramirezg	Engineering Consultant 4	MC - 11/21/19 - La Costa Grill - Lunch Gustavo and James	EXP	1.00	41.820	38.02	41.82	
11/22/2019	ramirezg	Engineering Consultant 4	MC - 11/22/19 - Hilton Garden Inn - Hotel Reservation	EXP	1.00	1,114.470	1,013.15	1,114.47	
11/22/2019	ramirezg	Engineering Consultant 4	MC - 11/22/19 - Whataburger - Diner Gustavo	EXP	1.00	9.930	9.03	9.93	

*Raw*

*Gus*

Invoice No: **INV065075**

Task ID	Date	User ID	Employee Class	Billing Description	Pay Code	Qty	Bill Rate	Cost:Amount	Bill Amount
EXP - MARK UP	11/30/2019	ramirezg	Engineering Consultant 4	MC - 11/15/19 - Chic-Fil-A - Lunch Gustavo	EXP	1.00	7.890	7.89	7.89
					<b>General Project Expense</b>	<b>Task Totals</b>	26.00		1,947.85
EXP - MILEAGE <i>Grus Jerry</i>	11/20/2019	landryjer	Senior Lead Eng Consultant	Travel to Houston office for pre-mobilization meeting	EXP	62.60	0.580	49.45	36.31
	11/13/2019	ramirezg	Engineering Consultant 4	Mileage from Houston to McAllen	EXP	360.00	0.580	208.80	208.80
	11/14/2019	ramirezg	Engineering Consultant 4	Mileage from Field to Hotel	EXP	6.00	0.580	3.48	3.48
	11/15/2019	ramirezg	Engineering Consultant 4	Mileage from Field to Hotel	EXP	6.00	0.580	3.48	3.48
	11/16/2019	ramirezg	Engineering Consultant 4	Mileage from Hotel to Worksite	EXP	6.00	0.580	3.48	3.48
	11/18/2019	ramirezg	Engineering Consultant 4	Mileage from Hotel to Worksite	EXP	6.00	0.580	3.48	3.48
	11/19/2019	ramirezg	Engineering Consultant 4	Mileage from Hotel to Worksite	EXP	6.00	0.580	3.48	3.48
	11/20/2019	ramirezg	Engineering Consultant 4	Mileage from Hotel to Worksite	EXP	6.00	0.580	3.48	3.48
	11/21/2019	ramirezg	Engineering Consultant 4	Mileage from Hotel to Worksite	EXP	6.00	0.580	3.48	3.48
	11/22/2019	ramirezg	Engineering Consultant 4	Mileage from McAllen to Houston	EXP	366.00	0.580	212.28	212.28
					<b>Mileage - Unit 0.79</b>	<b>Task Totals</b>	830.60		494.89
EXP - SOFTWARE	11/16/2019	Software	Software Charges	Software charge - CAD	EXP	8.50	12.000	102.00	102.00
					<b>Software - 12 CAD / 25 SACS</b>	<b>Task Totals</b>	8.50		102.00
<b>Expenses Total</b>						<b>865.10</b>			<b>\$ 2,726.37</b> ✓

Total Invoice Amount: \$ 39,584.72 ✓



## CAMS Midstream Services, LLC

919 Milam Street, Suite 2300 Houston, TX 77002-5418

TO: Lonestar Pipeline Company, LLC  
 c/o Frontera Energy Center  
 900 S Goodwin Road  
 Mission, TX 78572

Attention: Ed Fuselier  
[ed.fuselier@kindle-energy.com](mailto:ed.fuselier@kindle-energy.com)

Invoice No.: LONPIP 20200131  
 Date: 19-Feb-2020  
 Due Date: 5-Mar-2020  
 Prepared by: W. Hankins 713-358-9712

Pursuant to the terms of the Pipeline Services Agreement dated 11/1/2014 by and between Consolidated Asset Management Services, LLC ("CAMS") and Lonestar Pipeline Company, LLC (d/b/a Rio Grande Interstate Pipeline LLC) ("Lonestar"); Non-Routine fees per "Exhibit 1" to the above contract:

**Other Non-Routine Services:**

CAMS Trident - Locate and Mark Lines ( Inv# 070596 dated 01/31/20)	4,946.82
CAMS Trident - ROW Signs ( Inv# 070390 dated 01/20/20)	3,016.81
Enertech - 2020 Xchange Hosting Fee (Inv#1329 Dated 1/29/2020) plus 15% markup	143.75
M&H Enterprises - Eng Svc (Inv# INV065533 dated 2/10/20) plus 15% markup <b>Reimbursable by TX DOT</b>	<b>13,013.69</b>
Majic Valley Electric - January electric for rectifiers ( Inv# 290790-JAN dated 01/27/20)	66.54
Direct Energy - January electric ( Inv# 200370041111827 dated 2/6/20)	12.12
Direct Energy - January electric ( Inv# 200350041081803 dated 2/4/20)	35.47
Texas Excavation Safety System - Dec message fees ( Inv# 19-24390 dated 12/31/19)	76.00
Texas Excavation Safety System - Jan message fees ( Inv# 20-00564 dated 01/31/20)	77.90

**TOTAL AMOUNT DUE: \$ 21,389.10**

**Wire Instructions:**  
 CAMS Midstream Services, LLC  
 Amegy Bank  
 ABA#: 113011258  
 Account: 5791158149

CO	Coding:		Subaccount				Amount
CAMSTEX	Acct						
LONPIP	1110000	137	000	00	00	0000	21,389.10
	1140000	137	000	00	00	0000	0.00
	3050000	137	354	00	00	0000	0.00
	3055000	137	354	00	00	0000	(21,389.10)



M&H Enterprises Inc.  
 dba M&H Energy Services  
 19450 HWY 249, Suite 600  
 Houston, TX 77070  
 (281) 664-7222

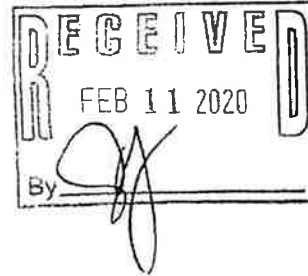

# INVOICE

**Bill To: CAMS Midstream**

Colin Harper  
 919 Milam Street  
 Suite 2300  
 Houston, Texas 77002

Invoice Date: 2/10/2020  
 Invoice No: INV065533  
 Terms:

For services rendered for the calendar month ending **January 31, 2020**

**M&H Project No: 17MH033 Dicker Road Hidalgo County**

Inquiries can be sent to [charper@camstex.com](mailto:charper@camstex.com)

**PROFESSIONAL SERVICES**

Design Supervisor  
 Engineering Consultant 4  
 Project Controls Coordinator 2  
 Purchasing Manager  
 Senior Project Director  
 Specialist Engineering Consult

	Rate	Qty	Amount
	176.00	1.00	\$ 176.00
	101.00	7.00	\$ 707.00
	101.00	8.00	\$ 808.00
	165.00	17.75	\$ 2,928.75
	200.00	33.00	\$ 6,600.00
	169.00	0.50	\$ 84.50
		67.25	\$ 11,304.25

**EXPENSES**

\$ 12.00

Total Invoice Amount: **\$ 11,316.25**

Project Manager: R. Perego

*[Signature]* 2.11.20  
 RE: Hunter - Dicker Road  
 Project Closeout Review

Task ID	Date	User ID	Employee Class	Billing Description	Pay Code	Qty	Bill Rate	Cost Amount	Bill Amount
---------	------	---------	----------------	---------------------	----------	-----	-----------	-------------	-------------

**M&H Project No: 17MH033 Dicker Road Hidalgo County**

**Professional Services**

ENG-PC-1	1/7/2020	peregor	Senior Project Director	Project management	EXEMPT	2.00	200.00		400.00
	1/9/2020	peregor	Senior Project Director	Conference call, test specimens, invoices, TIC estimate	EXEMPT	7.00	200.00		1,400.00
	1/13/2020	peregor	Senior Project Director	Invoice review, Total Cost Estimate	EXEMPT	6.00	200.00		1,200.00
	1/14/2020	peregor	Senior Project Director	Invoice review, Total Cost Estimate, specimen testing	EXEMPT	4.00	200.00		800.00
	1/15/2020	peregor	Senior Project Director	Job books	EXEMPT	2.00	200.00		400.00
	1/16/2020	peregor	Senior Project Director	Specimen testing proposals	EXEMPT	3.00	200.00		600.00
	1/23/2020	peregor	Senior Project Director	Review metallurgical testing proposals	EXEMPT	1.00	200.00		200.00
	1/27/2020	peregor	Senior Project Director	Metallurgical testing, TXDOT update	EXEMPT	2.00	200.00		400.00
	1/28/2020	peregor	Senior Project Director	Update as-built drawings, TXDOT update	EXEMPT	2.00	200.00		400.00
	1/30/2020	peregor	Senior Project Director	Detailed job book review/update	EXEMPT	4.00	200.00		800.00
				<b>Project Coordination - Management Task Totals</b>		<b>33.00</b>			<b>\$ 6,600.00</b>
ENG-PC-2	1/9/2020	linscombek	Project Controls Coordinator 2	Project Controls, Conf Call, Cost Report	HOURLY	1.50	101.00		151.50
	1/27/2020	linscombek	Project Controls Coordinator 2	Project Controls, Cost Report/PAR	HOURLY	0.50	101.00		50.50
	1/30/2020	linscombek	Project Controls Coordinator 2	Project Controls, Job Books, TIC Estimate	HOURLY	6.00	101.00		606.00
				<b>Project Coordination - Controls Task Totals</b>		<b>8.00</b>			<b>\$ 808.00</b>
ENG-PC-3	1/14/2020	arnesonp	Specialist Engineering Consult	Material testing and verification support	EXEMPT	0.50	169.00		84.50
	1/30/2020	ramirezg	Engineering Consultant 4	TxDOT Construction Coordination	EXEMPT	1.00	101.00		101.00
	1/6/2020	smiths	Purchasing Manager	Invoice review, correspondence with Strike and review of As Built drawing packages from Strike, send request to Stress Eng for metallurgy review	EXEMPT	1.00	165.00		165.00

Task ID	Date	User ID	Employee Class	Billing Description	Pay Code	Qty	Bill Rate	Cost Amount	Bill Amount
ENG-PC-3	1/7/2020	smiths	Purchasing Manager	Invoice review, following up with suppliers on invoices	EXEMPT	0.25	165.00		41.25
	1/8/2020	smiths	Purchasing Manager	Invoice review, following up with suppliers on invoices and coupon testing	EXEMPT	1.50	165.00		247.50
	1/9/2020	smiths	Purchasing Manager	Invoice review, following up with suppliers on invoices	EXEMPT	3.00	165.00		495.00
	1/10/2020	smiths	Purchasing Manager	Invoice review, following up with suppliers on invoices. D&A policy info	EXEMPT	1.50	165.00		247.50
	1/13/2020	smiths	Purchasing Manager	Vendor correspondence/invoice review	EXEMPT	2.00	165.00		330.00
	1/15/2020	smiths	Purchasing Manager	Vendor correspondence and coordination on data for PHMSA audit	EXEMPT	3.00	165.00		495.00
	1/16/2020	smiths	Purchasing Manager	Vendor correspondence and coordination on data for PHMSA audit	EXEMPT	2.50	165.00		412.50
	1/17/2020	smiths	Purchasing Manager	Vendor correspondence and coordination on data for PHMSA audit, RFQ and correspondence with metallurgists	EXEMPT	1.50	165.00		247.50
	1/28/2020	smiths	Purchasing Manager	Vendor correspondence on invoices	EXEMPT	1.00	165.00		165.00
			<b>Project Coordination - General</b>	<b>Task Totals</b>		<b>18.75</b>			<b>\$ 3,031.75</b>
ENG-PC-5	1/9/2020	ramirezg	Engineering Consultant 4	Status Update Meeting	EXEMPT	0.50	101.00		50.50
	1/9/2020	smiths	Purchasing Manager	Project team meeting and call with client	EXEMPT	0.50	165.00		82.50
				<b>Project Coordination - Meetings</b>	<b>Task Totals</b>	<b>1.00</b>			<b>\$ 133.00</b>
PL-AS	1/6/2020	ramirezg	Engineering Consultant 4	As-Built Review	EXEMPT	0.50	101.00		50.50
	1/7/2020	ramirezg	Engineering Consultant 4	As-Built Review	EXEMPT	2.00	101.00		202.00
	1/9/2020	ramirezg	Engineering Consultant 4	As-Built Submittal	EXEMPT	0.50	101.00		50.50
	1/10/2020	ramirezg	Engineering Consultant 4	As-Built Submittal	EXEMPT	1.00	101.00		101.00
	1/13/2020	ramirezg	Engineering Consultant 4	TXDOT As-Built Submittal	EXEMPT	1.00	101.00		101.00
	1/28/2020	ramirezg	Engineering Consultant 4	As-Built Submittal to TxDOT	EXEMPT	0.50	101.00		50.50
			<b>Alignment Sheets</b>	<b>Task Totals</b>	<b>5.50</b>				<b>\$ 555.50</b>

Invoice No: **INV065533**

Task ID	Date	User ID	Employee Class	Billing Description	Pay Code	Qty	Bill Rate	Cost Amount	Bill Amount
PL-AS-D	1/28/2020	smithj	Design Supervisor	Reissue pipeline crossing set with minor revisions	HOURLY	1.00	176.00		176.00
				Alignment Sheets - AutoCAD Drawing	Task Totals	1.00			\$ 176.00
				<b>Professional Services Total</b>		<b>67.25</b>			<b>\$ 11,304.25</b>

**Expenses**

EXP - SOFTWARE	1/31/2020	Software	Software Charges	Software charge - CAD	EXP	1.00	12.000	12.00	12.00
				Software - 12 CAD / 25 SACS	Task Totals	1.00		12.00	\$ 12.00
				<b>Expenses Total</b>		<b>1.00</b>			<b>\$ 12.00</b>

**Total Invoice Amount: \$ 11,316.25**



**CAMS Midstream Services, LLC**

919 Milam Street, Suite 2300 Houston, TX 77002-5418

TO: Lonestar Pipeline Company, LLC  
 c/o Frontera Energy Center  
 900 S Goodwin Road  
 Mission, TX 78572

Attention: Ed Fuselier  
 ed.fuselier@kindle.energy.com

Invoice No.: LONPIP 20200131 #2  
 Date: 19-Feb-2020  
 Due Date: 5-Mar-2020  
 Prepared by: W. Hankins  
 713-358-9712

Pursuant to the terms of the Pipeline Services Agreement dated 11/1/2014 by and between Consolidated Asset Management Services, LLC ("CAMS") and Lonestar Pipeline Company, LLC (d/b/a Rio Grande Interstate Pipeline LLC) ("Lonestar"); Non-Routine fees per "Exhibit 1" to the above contract:

**Other Non-Routine Services:**

CAMS Trident - Locate and Mark Lines ( Inv# 071203 dated 02/29/20)	5,201.32
M&H Enterprises - Eng Svc (Inv# INV065813 dated 3/9/20) plus 15% markup <b>Reimbursable by TX DOT</b> TxDOT Reimbursable	<b>7,270.30</b>
M&H Enterprises - Eng Svc (Inv# INV066061 dated 3/5/20) plus 15% markup	725.08
Majic Valley Electric - February electric for rectifiers ( Inv# 290790-FEB dated 02/26/20)	78.00
Direct Energy - February electric ( Inv# 20066041413735 dated 3/6/20)	12.12
Direct Energy - February electric ( Inv# 20066041410323 dated 3/6/20)	42.10
Texas Excavation Safety System - Feb message fees ( Inv# 20-02404 dated 02/29/20)	112.10
Amegy Bank Letter of Credit Fees dated 1/31/20	810.42
Railroad Commission of Texas Inv#455RM004Q0A2JU4 dated 1/31/20	511.51
Railroad Commission of Texas Inv#455RM004Q0Q7GN1 1/31/20	409.26

**TOTAL AMOUNT DUE:**

**\$ 14,251.44**

**Wire Instructions:**  
 CAMS Midstream Services, LLC  
 Amegy Bank  
 ABA#: 113011258  
 Account: 5791158149

CO	Coding:		Subaccount				Amount
CAMSTEX	Acct						
LONPIP	1110000	137	000	00	00	0000	14,251.44
	1140000	137	000	00	00	0000	0.00
	3050000	137	354	00	00	0000	0.00
	3055000	137	354	00	00	0000	(14,251.44)

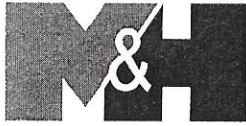

M&H Enterprises Inc.  
 dba M&H Energy Services  
 19450 HWY 249, Suite 600  
 Houston, TX 77070  
 (281) 664-7222

# INVOICE

**Bill To: CAMS Midstream**

Colin Harper  
 919 Milam Street  
 Suite 2300  
 Houston, Texas 77002

Invoice Date: 3/9/2020  
 Invoice No: INV065813  
 Terms:

For services rendered for the calendar month ending **February 29, 2020**

**M&H Project No: 17MH033 Dicker Road Hidalgo County**

Inquiries can be sent to charper@camstex.com

**PROFESSIONAL SERVICES**

	Rate	Qty	Amount
Project Controls Coordinator 2	101.00	15.00	\$ 1,515.00
Project Controls Coordinator 3	84.00	0.50	\$ 42.00
Purchasing Manager	165.00	1.00	\$ 165.00
Senior Project Director	200.00	23.00	\$ 4,600.00
		39.50	\$ 6,322.00

3055600-137-354-00-00-0000

Total Invoice Amount: **\$ 6,322.00**

*[Handwritten Signature]* 3.10.20  
 RE: Lenestas P/L  
 Dicker Road Relocation  
 (TX DOT Project)

Project Manager: R. Perego

- BILLAGE -

Task ID	Date	User ID	Employee Class	Billing Description	Pay Code	Qty	Bill Rate	Cost Amount	Bill Amount
---------	------	---------	----------------	---------------------	----------	-----	-----------	-------------	-------------

**M&H Project No: 17MH033 Dicker Road Hidalgo County**

**Professional Services**

<i>Rios</i>	ENG-PC-1	2/3/2020	peregor	Senior Project Director	Review invoices	EXEMPT	2.00	200.00	400.00
		2/4/2020	peregor	Senior Project Director	Job book, reimbursables, TIC estimate, casing removal	EXEMPT	5.00	200.00	1,000.00
		2/5/2020	peregor	Senior Project Director	Review invoices, reimbursables, TIC estimate	EXEMPT	5.00	200.00	1,000.00
		2/6/2020	peregor	Senior Project Director	Plan casing removal, project management	EXEMPT	2.00	200.00	400.00
		2/7/2020	peregor	Senior Project Director	Review master job book, plan casing removal	EXEMPT	1.00	200.00	200.00
		2/7/2020	peregor	Senior Project Director	Respond to 6" pipeline found by storm sewer crew in Hidalgo	EXEMPT	1.00	200.00	200.00
		2/11/2020	peregor	Senior Project Director	Coordinate casing removal	EXEMPT	1.00	200.00	200.00
		2/12/2020	peregor	Senior Project Director	Review final job books	EXEMPT	1.00	200.00	200.00
		2/17/2020	peregor	Senior Project Director	TxDOT reimbursement process, call to Eddie Rios	EXEMPT	1.00	200.00	200.00
		2/18/2020	peregor	Senior Project Director	Reconcile CAMS invoices vs TIC estimate	EXEMPT	2.00	200.00	400.00
		2/19/2020	peregor	Senior Project Director	TxDOT reimbursable estimate, supporting invoices	EXEMPT	2.00	200.00	400.00
					<b>Project Coordination - Management Task Totals</b>		<b>23.00</b>		<b>\$ 4,600.00</b> ✓
<i>KAZAL</i>	ENG-PC-2	2/4/2020	linscombek	Project Controls Coordinator 2	Project Controls, Weekly Cost Report, Job Book-Master Copy	HOURLY	4.50	101.00	454.50
		2/5/2020	linscombek	Project Controls Coordinator 2	Project Controls, Trans 0010 - Updated TICs	HOURLY	1.50	101.00	151.50
		2/10/2020	linscombek	Project Controls Coordinator 2	Duplicate Job Books x3	HOURLY	3.00	101.00	303.00
		2/12/2020	linscombek	Project Controls Coordinator 2	Project Controls, Job Books	HOURLY	2.00	101.00	202.00
		2/19/2020	linscombek	Project Controls Coordinator 2	Project Controls, Discuss TxDOT Inv Rev, Cost Report	HOURLY	1.00	101.00	101.00
		2/20/2020	linscombek	Project Controls Coordinator 2	Project Controls	HOURLY	1.00	101.00	101.00
		2/28/2020	linscombek	Project Controls Coordinator 2	TXDOT Reimbursable Invoicing Controls	HOURLY	2.00	101.00	202.00

Invoice No: **INV065813**

Task ID	Date	User ID	Employee Class	Billing Description	Pay Code	Qty	Bill Rate	Cost Amount	Bill Amount
ENG-PC-2	2/12/2020	salamancas	Project Controls Coordinator 3	Project Controls, Job Books	HOURLY	0.50	84.00		42.00
				<b>Project Coordination - Controls</b>	<b>Task Totals</b>	<b>15.50</b>			<b>\$ 1,557.00</b>
ENG-PC-3	2/4/2020	smiths	Purchasing Manager	Apex invoice versus credit review	EXEMPT	1.00	165.00		165.00
				<b>Project Coordination - General</b>	<b>Task Totals</b>	<b>1.00</b>			<b>\$ 165.00</b>
				<b>Professional Services Total</b>		<b>39.50</b>			<b>\$ 6,322.00</b>

Total Invoice Amount: \$ 6,322.00

STATE OF TEXAS

§

COUNTY OF HIDALGO

§

§

## RIGHT OF ENTRY AGREEMENT

THIS RIGHT OF ENTRY AGREEMENT (this “**Agreement**”) is made on this 28th day of October, 2019, by and between Valle de los Tesoros, Ltd., a Texas limited partnership, whose address is 3900 N. McColl Road, McAllen, Texas 78501 (“**VDLT**”), and Lonestar Pipeline Company, LLC d/b/a Rio Grande Intrastate Pipeline in Texas, a Delaware limited liability company, whose address is c/o Kindle Energy LLC, 500 Alexander Park Drive, Suite 300, Princeton, NJ 08540 (“**Lonestar**”).

WHEREAS, VDLT is the owner of the land described in **Exhibit “A”**, which is attached hereto and made a part hereof for all purposes (the “**Property**”); and

WHEREAS, Lonestar has requested a right of entry onto the Property for the limited purpose of adjusting and relocating the existing utility gas line on the Property (the “**Project**”); and

WHEREAS, VDLT has agreed to grant its permission for such limited right of entry subject to the terms and provisions of this Agreement.

NOW, THEREFORE, in consideration of the premises and the covenants set forth in this Agreement, and other good and valuable consideration the receipt and sufficiency of which being hereby acknowledged, VDLT and Lonestar hereby agree as follows:

1. **Limited Use.** In <sup>TxDOT</sup> <sup>Reimbursable</sup> consideration of the payment by Lonestar to VDLT of Forty Thousand and No/100ths Dollars (**\$40,000.00**), which shall be due immediately upon execution of this Agreement, Lonestar may use portions of the Property for the limited purpose of adjusting and relocating the existing utility gas line on the Property, including the construction reasonably necessary for such purpose. Access to the Property shall be requested not less than twenty-four (24) hours in advance by calling Greg LaMantia at (956) 687-7751.

2. **Claim of Ownership.** The parties agree that VDLT does not waive its claim to ownership in the Property by signing this Agreement. VDLT does give permission for Lonestar, including its agents and employees, to enter upon the Property pursuant to the terms of this Agreement.

3. **Disruption to Property.** Any fences, gates, buildings or other structures affected by the Project will be returned to their original condition by Lonestar.

4. **Use of Facilities.** Lonestar shall not have the right to use any buildings or other structures on the Property, construct any buildings or other structures on the Property (except as otherwise described herein), or use any timber, natural resources, water or other products found on the Property. Notwithstanding the foregoing, the Parties acknowledge and agree that Lonestar

will replace the existing test station with a new test station at or near the location of the existing station and may also install a guard rail around such new test station to protect it.

5. **Term.** The effective date of this Agreement shall be October 28, 2019. The right of entry granted herein shall be effective from October 28, 2019 to December 19, 2019.

6. **Waste Removal.** At all times during this Agreement, Lonestar shall keep the Property free and clear of all trash, debris and waste. At the termination of this Agreement, Lonestar shall remove all trash, waste, debris and other items brought on the Property by Lonestar.

7. **No Sale or Dedication.** VDLT gives to Lonestar the right to enter the Property, and only the right to enter. This is not a sale of land. Lonestar shall give VDLT prior written notice of Lonestar's intention to enter the Property and shall advise VDLT in such notice of the identity of the individuals authorized by Lonestar to enter the Property. Lonestar agrees to use such means of ingress and egress to the Property as reasonably instructed by VDLT.

8. **Protection of Property.** Lonestar will endeavor to use reasonable caution in its use of the Property to prevent injury to all persons, wildlife, crops, livestock, game animals and other property and it will indemnify VDLT against any damages that may be assessed against it by reason of the use herein permitted.

9. **Prohibited Uses.** Lonestar shall not permit or allow its agents, contractors, employees, invitees, licensees and/or visitors to bring firearms, alcohol or drugs onto the Property or hunt on the Property. Lonestar acknowledges and agrees that it shall enforce a "No Tolerance" policy with respect to firearms, alcohol and drugs on the Property and shall remove and bar from the Property any of its agents, contractors, employees, invitees, licensees and/or visitors found on the Property with such items.

10. **Indemnification.** Lonestar shall indemnify, protect, defend and hold harmless VDLT, and its partners, members, managers, directors, partners, officers, employees and agents (the "**Indemnified Parties**"), from and against any and all third-party claims, costs, liabilities, losses, damages, injuries, judgments, and expenses (collectively, "**Claims**") including, without limitation, reasonable attorneys' fees, court costs, including those incurred at the trial and appellate levels and other legal expenses, arising out of or resulting from any injury or death to any third party or injury to any third party's property, received or sustained by any person or persons or property, arising out of, occasioned by or related in any way, directly or indirectly, to the entry on the Property by Lonestar, its agents, officers, employees or contractors, **except for third party Claims arising in whole or in part from the negligence of the Indemnified Parties or as otherwise prohibited by law.** The Indemnified Parties shall give Lonestar prompt notice of any Claims coming within the purview of this indemnity. Upon the written request of the Indemnified Parties, Lonestar shall assume the defense of any Claims against the Indemnified Parties with counsel reasonably acceptable to the Indemnified Parties and will permit the Indemnified Parties, at their expense, to participate in the defense thereof. The provisions of this Section 10 shall survive the expiration of this Agreement and shall be binding upon Lonestar, its successors and assigns.

11. **Insurance.** Lonestar shall provide VDLT, on or before the execution of this Agreement, with a certified copy with all endorsements attached thereto of Lonestar's or, as applicable, its general contractor's commercial general liability insurance policy, which policy shall have at least One Million and No/100ths Dollars (\$1,000,000.00) single limit liability for each occurrence. Such insurance policy shall list VDLT as an additional insured under the policy, which policy shall include a contractual liability endorsement to cover Lonestar's obligations under this Agreement. Coverage under the policy as it pertains to VDLT shall apply on a primary and noncontributory basis with any other insurance available to VDLT, and the insurer will not seek contribution from any other insurance of VDLT, whether primary, excess or contingent, and even though such other insurance provides that it is primary insurance. Coverage under the policy shall be on an occurrence rather than a claims made basis. The policy shall also be endorsed to provide that VDLT will be notified of the cancellation or any restrictive amendment of the policy at least thirty (30) days before the effective date of such cancellation or amendment. Lonestar shall not violate, or permit to be violated, any conditions of said insurance policy, and Lonestar shall at all times satisfy the requirements of the insurance company writing said policy. The failure to provide such certificate in the manner and time required or to maintain the insurance coverage specified herein shall be deemed a material breach of this Agreement.

12. **Governing Law.** This Agreement shall be construed under and in accordance with the laws of the State of Texas, without reference to its choice of law principles. Venue and jurisdiction for any cause of action hereunder shall lie exclusively in Hidalgo County, Texas.

13. **Gender.** Wherever the context shall so require, all words herein in the male gender shall be deemed to include the female or neuter gender, and vice versa, all singular words shall include the plural, and all plural words shall include the singular.

14. **Entire Agreement.** This Agreement constitutes the entire agreement of the parties and supersedes all prior negotiations, commitments, representations and undertakings of the parties with respect to the subject matter hereof.

15. **Default.** In the event either party breaches any of the terms of this Agreement whereby the party not in default employs attorneys to protect or enforce its rights hereunder and prevails, then the defaulting party agrees to pay the other party reasonable attorneys' fees so incurred by such party. The prevailing party shall also recover court costs (including the cost of any bond) and necessary expenses reasonably incurred by reason of litigation or the cure of any default by the opposing party.

16. **Notices.** All notices, demands, requests or communications required or permitted hereunder shall be in writing and shall either be: (a) personally delivered against a written receipt therefor; or (b) sent by reputable overnight courier or by certified mail, return receipt requested, postage prepaid and addressed to the parties at the addresses set forth above or at such other addresses as may have been theretofore specified by written notice delivered in accordance herewith. Each notice, demand, request or communication which shall be delivered or mailed in the manner described above shall be deemed sufficiently given for all purposes at such time as it

is personally delivered to the addressee or, if mailed, at such time as it is deposited in the United States mail, or, if overnighted, at such time as the courier delivers or first attempts to deliver the notice.

17. **Severability.** If any one or more of the provisions contained in this Agreement for any reason are held to be invalid, illegal or unenforceable in any respect, such invalidity, illegality or unenforceability shall not affect any other provision hereof and this Agreement shall be construed as if such invalid, illegal or unenforceable provision had never been contained herein.

18. **Counterparts.** This Agreement may be executed in multiple counterparts, each of which shall be deemed an original and all of which shall constitute one agreement, and the signatures of any party to any counterpart shall be deemed to be a signature to, and may be appended to, any other counterpart.

19. **Amendment.** No amendment, modification or alteration of the terms hereof shall be binding unless the same be in writing, dated subsequent to the date hereof and duly executed by the parties hereto.

20. **Waiver.** No waiver by the parties hereto of any default or breach of any term, condition or covenant of this Agreement shall be deemed to be a waiver of any other breach of the same or any other term, condition, or covenant contained herein.

21. **Authorization.** The execution and performance of this Agreement by each of the parties hereto have been duly authorized by all necessary laws, resolutions, ordinances or governing body action, and this Agreement constitutes the valid and enforceable obligations of the parties hereto in accordance with its terms.

22. **Costs of Agreement.** Each party hereto is entering into this Agreement for the purpose of providing for governmental services or functions, and will pay for such services out of current revenues available to the paying party as herein provided.

23. **Existing Easements or Rights of Way.** Nothing in this Agreement shall limit, constrain, or otherwise affect any existing easements, rights of way, or access rights that currently exist among the Parties with respect to the Property, which shall remain in full force and effect.

[Signature Page Follows]

IN WITNESS WHEREOF, the undersigned have executed this Agreement effective as of the date first written above.

**VDLT:**

VALLE DE LOS TESOROS, LTD.

By: Valle de los Tesoros GP, LLC, its General Partner

By: Muy Buena Suerte, Ltd., its Manager

By: Apuesta, LLC, its Manager

By: \_\_\_\_\_  
Greg LaMantia, Manager

**LONESTAR:**

LONESTAR PIPELINE COMPANY, LLC

By: David Neal  
David Neal, Vice President

IN WITNESS WHEREOF, the undersigned have executed this Agreement effective as of the date first written above.

**VDLT:**

VALLE DE LOS TESOROS, LTD.

By: Valle de los Tesoros GP, LLC, its General Partner

By: Muy Buena Suerte, Ltd., its Manager

By: Apuesta, LLC, its General Partner

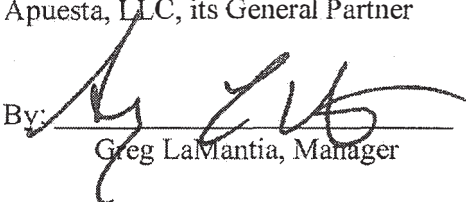
By:   
Greg LaMantia, Manager

**LONESTAR:**

LONESTAR PIPELINE COMPANY, LLC

By: \_\_\_\_\_

**EXHIBIT "A"**

**Legal Description of the Property**

**EXHIBIT "B"**  
**TRACT 1 - 1.014 ACRES**  
**OUT OF LOT 11, SECTION 3,**  
**HIDALGO CANAL COMPANY'S SUBDIVISION**  
**VOLUME Q, PG. 177, D.R.H.C.**  
**TO ACCOMPANY FIELD NOTES**

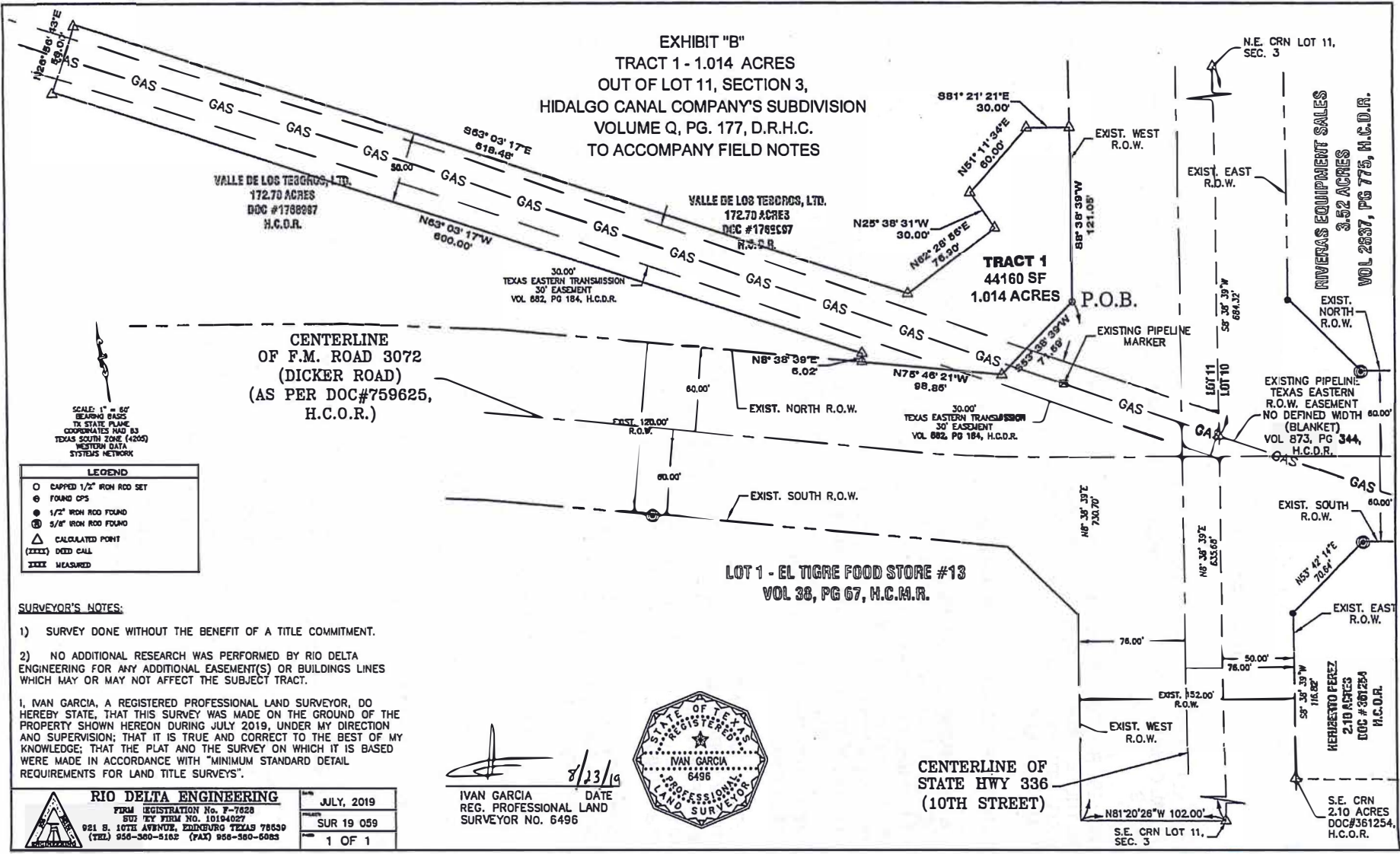

SCALE: 1" = 60'  
 BEARING BASED  
 TO STATE PLANE  
 COORDINATES NAD 83  
 TEXAS SOUTH ZONE (4205)  
 WESTERN DATUM  
 SYSTEMS NETWORK

LEGEND	
○	CHIPPED 1/2" IRON ROD SET
●	FOUND GPS
⊙	1/2" IRON ROD FOUND
⊗	3/8" IRON ROD FOUND
△	CALCULATED POINT
(XXXX)	DEED CALL
XXXX	MEASURED

**SURVEYOR'S NOTES:**

- 1) SURVEY DONE WITHOUT THE BENEFIT OF A TITLE COMMITMENT.
  - 2) NO ADDITIONAL RESEARCH WAS PERFORMED BY RIO DELTA ENGINEERING FOR ANY ADDITIONAL EASEMENT(S) OR BUILDINGS LINES WHICH MAY OR MAY NOT AFFECT THE SUBJECT TRACT.
- I, IVAN GARCIA, A REGISTERED PROFESSIONAL LAND SURVEYOR, DO HEREBY STATE, THAT THIS SURVEY WAS MADE ON THE GROUND OF THE PROPERTY SHOWN HEREON DURING JULY 2019, UNDER MY DIRECTION AND SUPERVISION; THAT IT IS TRUE AND CORRECT TO THE BEST OF MY KNOWLEDGE; THAT THE PLAT AND THE SURVEY ON WHICH IT IS BASED WERE MADE IN ACCORDANCE WITH "MINIMUM STANDARD DETAIL REQUIREMENTS FOR LAND TITLE SURVEYS".

*Ivan Garcia*  
 8/23/19



IVAN GARCIA DATE  
 REG. PROFESSIONAL LAND SURVEYOR No. 6496

	<b>RIO DELTA ENGINEERING</b>	
	FIRM REGISTRATION No. F-7628	DATE
	SUR 19 059	
	1 OF 1	

921 E. 10TH AVENUE, EDINBURG TEXAS 78539  
 (TEL) 956-360-5182 (FAX) 956-560-6083

CENTERLINE OF  
 STATE HWY 336  
 (10TH STREET)

**EXHIBIT A  
TRACT 1- 1.014 ACRES  
OUT OF LOT 11, SECTION 3,  
HIDALGO CANAL COMPANY SUBDIVISION,  
VOLUME Q, PAGE 177,  
DEED RECORDS OF HIDALGO COUNTY, TEXAS  
FIELD NOTES**

BEING A 1.014 ACRES TRACT OF LAND OUT OF AND FORMING A PART OR PORTION OF LOT 11, SECTION 3, HIDALGO CANAL COMPANY SUBDIVISION, RECORDED IN VOLUME Q, PAGE 177, DEED RECORDS OF HIDALGO COUNTY, TEXAS,

SAID 1.014 ACRES TRACT BEING OUT OF A CALLED 172.70 ACRES TRACT DESCRIBED IN A GENERAL WARRANTY DEED FROM THESE PARTNERS, LTD, FRANK THESE, JR, JOCE LOCKE, AND JANET NOLAND TO VALLE DE LOS TESOROS, LTD, DATED JUNE 5, 2007, RECORDED IN DOCUMENT #1768997, OFFICIAL RECORDS OF HIDALGO COUNTY, TEXAS;

AND SAID 1.014 ACRES TRACT BEING MORE PARTICULARLY DESCRIBED BY METES AND BOUNDS AS FOLLOWS;

**BEGINNING AT THE POINT OF INTERSECTION BETWEEN THE EXISTING NORTH RIGHT-OF-WAY LINE OF F.M. ROAD 3072 (DICKER RD.) AND THE EXISTING WEST RIGHT-OF-WAY LINE (MOST NORTHERLY CORNER OF THE NORTHWEST CORNER CLIP) OF STATE HIGHWAY 336 (S. 10<sup>TH</sup> STREET), SAME POINT BEING THE NORTHEAST CORNER OF A CALLED TRACT #3 DESCRIBED IN A HIGHWAY RIGHT-OF-WAY EASEMENT DEED CONVEYED TO THE COUNTY OF HIDALGO AND THE STATE OF TEXAS, RECORDED IN DOCUMENT # 759625, OFFICIAL RECORDS OF HIDALGO COUNTY, TEXAS, A 1/2-INCH CAPPED IRON ROD SET, AND SAID 1/2-INCH CAPPED IRON ROD SET BEING DISTANT N 81°20'26" W 102.00 FEET AND N 8°38'39" E 730.70 FEET FROM THE SOUTHEAST CORNER OF THE SAID LOT 11, FOR THE MOST EASTERLY SOUTHEAST CORNER OF THE HEREIN DESCRIBED TRACT AND THE POINT OF BEGINNING;**

**THENCE S 53°38'39" W ALONG THE EXISTING RIGHT-OF-WAY LINE OF F.M. ROAD 3072 (CORNER CLIP), TO THE MOST WESTERLY CORNER OF THE NORTHWEST CORNER CLIP OF INTERSECTION BETWEEN THE EXISTING NORTH RIGHT-OF-WAY LINE OF F.M. ROAD 3072 (DICKER RD.) AND THE EXISTING WEST RIGHT-OF-WAY LINE OF STATE HIGHWAY 336 (S. 10<sup>TH</sup> STREET), A DISTANCE OF 71.59 FEET TO A CALCULATED POINT, FOR THE MOST SOUTHERLY SOUTHEAST CORNER OF THE HEREIN DESCRIBED TRACT;**

**THENCE N 75°46'21" W ALONG THE EXISTING NORTH RIGHT-OF-WAY LINE OF F.M. ROAD 3072 (DICKER RD.), A DISTANCE OF 98.85 FEET TO A CALCULATED POINT, FOR THE MOST SOUTHERLY SOUTHWEST CORNER OF THE HEREIN DESCRIBED TRACT;**

**THENCE N 8°38'39" W ACROSS THE SAID 172.70 ACRES TRACT, A DISTANCE OF 6.02 FEET TO A CALCULATED POINT, FOR A CORNER OF THE HEREIN DESCRIBED TRACT;**

**THENCE N 63°03'17" W ACROSS THE SAID 172.70 ACRES TRACT, A DISTANCE OF 600.00 FEET TO A CALCULATED POINT, FOR THE MOST WESTERLY SOUTHWEST CORNER OF THE HEREIN DESCRIBED TRACT;**

**THENCE N 26°56'43" E ACROSS THE SAID 172.70 ACRES TRACT, A DISTANCE OF 50.00 FEET TO A CALCULATED POINT, FOR THE NORTHWEST CORNER OF THE HEREIN DESCRIBED TRACT;**

**THENCE S 63°03'17" E ACROSS THE SAID 172.70 ACRES TRACT, A DISTANCE OF 618.48 FEET TO A CALCULATED POINT, FOR A CORNER OF THE HEREIN DESCRIBED TRACT;**

**THENCE N 62°28'56" E ACROSS THE SAID 172.70 ACRES TRACT, A DISTANCE OF 76.90 FEET TO A CALCULATED POINT, FOR A CORNER OF THE HEREIN DESCRIBED TRACT;**

**THENCE N 25°38'31" W ACROSS THE SAID 172.70 ACRES TRACT, A DISTANCE OF 30.00 FEET TO A CALCULATED POINT, FOR A CORNER OF THE HEREIN DESCRIBED TRACT;**

**THENCE N 51°11'34" E ACROSS THE SAID 172.70 ACRES TRACT, A DISTANCE OF 60.00 FEET TO A CALCULATED POINT, FOR A CORNER OF THE HEREIN DESCRIBED TRACT;**

THENCE S 81°21'21" E ACROSS THE SAID 172.70 ACRES TRACT, TO A POINT ON THE EXISTING WEST RIGHT-OF-LINE OF STATE HIGHWAY 336 (S. 10<sup>TH</sup> STREET), A DISTANCE OF 30.00 FEET TO A CALCULATED POINT, FOR THE NORTHEAST CORNER OF THE HEREIN DESCRIBED TRACT;

THENCE S 8°38'39" W ALONG THE EXISTING WEST RIGHT-OF-WAY LINE OF STATE HIGHWAY 336 (S. 10<sup>TH</sup> STREET), A DISTANCE OF 121.05 FEET TO THE POINT AND PLACE OF BEGINNING, SAID TRACT CONTAINING 1.014 ACRES OF LAND, MORE OR LESS.

I, IVAN GARCIA, CERTIFY THAT THE ABOVE FIELD NOTES AND PLAT REPRESENT AN ACTUAL SURVEY ON THE GROUND MADE UNDER MY SUPERVISION, THAT THERE ARE NO VISIBLE EASEMENTS OR ENCROACHMENTS EXCEPT AS SHOWN, AND THAT ALL CORNERS HAVE BEEN LOCATED AS INDICATED.

 \_\_\_\_\_ 8/23/19 \_\_\_\_\_  
DATE

IVAN GARCIA  
REGISTERED PROFESSIONAL LAND SURVEYOR NO. 6496  
SURVEY FIRM NO. 10194027  
RIO DELTA ENGINEERING  
921 S. 10<sup>TH</sup> AVENUE  
EDINBURG, TEXAS 78539





**Notice of Confidentiality Rights: If you are a natural person, you may remove or strike any of the following information from this instrument before it is filed for record in the public records: your Social Security Number or your Driver's License Number.**

**TEMPORARY EASEMENT**

**THE STATE OF TEXAS** § **ROW CSJ: N/A**  
§  
**COUNTY OF HIDALGO COUNTY** § **KNOW ALL MEN BY THESE PRESENTS:**

That, Heriberto Perez of the County of Hidalgo, State of Texas, hereinafter referred to as Grantors, whether one or more, for and in consideration of the sum of **Twelve Thousand Eight Hundred Sixty-Three and No/100ths Dollars (\$12,863.00)** to Grantors in hand paid by Lonestar Pipeline Company, LLC (d/b/a Rio Grande Intrastate Pipeline in Texas) (“Lonestar Pipeline”), receipt of which is hereby acknowledged, and for which no lien is retained, either expressed or implied, do by these presents Grant, Bargain, Sell and Convey unto the Lonestar Pipeline, a temporary easement for the purpose of adjustment and/or relocation of utility gas line in, along, upon and across the property located in the County of Hidalgo, State of Texas, more particularly described in Exhibit “A”, which is attached hereto and incorporated herein for any and all purposes.

TxDOT  
Reimbursable

And for the same consideration described above and upon the same conditions, the Grantors have this day granted and conveyed and by these presents do grant and convey unto the Lonestar Pipeline any and all improvements presently existing upon the property described in said Exhibit “A”; SAVE and EXCEPT, HOWEVER, it is expressly understood and agreed that Grantors are retaining title to the following improvements located on the aforesaid property, to wit:  
N/A.

Grantors covenant and agree to remove the above-described improvements from said land by the N/A day of N/A, N/A, subject, however, to such extensions of time as may be granted by the County in writing; and if, for any reason, Grantors fail or refuse to remove same within said period of time prescribed, then, without any further consideration, the title to all or any part of such improvements not so removed shall pass to and vest in the Lonestar Pipeline forever.

This easement shall expire on the 19<sup>th</sup> day of December 2019, or on the date of completion of construction of the highway facility, whichever occurs first.

**TO HAVE AND TO HOLD** unto the said Lonestar Pipeline as aforesaid, for the purposes and on the conditions set forth hereinabove, the premises described in said Exhibit “A”.

IN WITNESS WHEREOF, this instrument is executed on this the 24 day of Oct., 2019.

*Heriberto Perez*  
Heriberto Perez

*Will Hood*  
Representative of Lonestar Pipeline, LLC  
d/b/a Rio Grande Intrastate Pipeline in Texas

**Acknowledgement**

State of Texas  
County of Hidalgo

This instrument was acknowledged before me on October 24, 2019

by Heriberto Perez

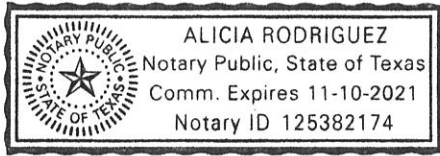

*Alicia Rodriguez*  
Notary Public's  
Signature

**Corporate Acknowledgment**

State of New Jersey  
County of Mercer

This instrument was acknowledged before me on October 9, 2019

by

Marissa Biegert, Notary Public

of Lonestar Pipeline Company, LLC, a Delaware LLC  
corporation, on behalf of said corporation.

*Marissa Biegert*  
Notary Public's Signature

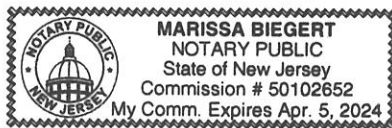



**EXHIBIT "A"**  
**TRACT 2 - 0.908 ACRES**  
**OUT OF LOT 10, SECTION 3,**  
**HIDALGO CANAL COMPANY'S SUBDIVISION**  
**VOLUME Q, PG. 177, D.R.H.C.**  
**TO ACCOMPANY FIELD NOTES**

VALLE DE LOS TESOROS, LTD.  
 172.70 ACRES  
 DOC #1722887  
 H.C.O.R.

30.00'  
 TEXAS EASTERN TRANSMISSION  
 30' EASEMENT  
 VOL. 882, PG. 164, H.C.D.R.

**CENTERLINE**  
**OF F.M. ROAD 3072**  
**(DICKER ROAD)**  
**(AS PER DOC#759625,**  
**H.C.O.R.)**

**LOT 1 - EL TIGRE FOOD STORE #13**  
**VOL 38, PG 67, H.C.M.R.**

**SURVEYOR'S NOTES:**

- 1) SURVEY DONE WITHOUT THE BENEFIT OF A TITLE COMMITMENT
- 2) NO ADDITIONAL RESEARCH WAS PERFORMED BY RIO DELTA ENGINEERING FOR ANY ADDITIONAL EASEMENTS OR BUILDING LINES WHICH MAY OR MAY NOT AFFECT THE SUBJECT TRACT.

I, IVAN GARCIA, A REGISTERED PROFESSIONAL LAND SURVEYOR, DO HEREBY SHOW, HEREON, DURING JULY 2019, UNDER MY DIRECTION AND SUPERVISION, THAT THE PLAT AND THE SURVEY ON THE LOT IS BASED WERE MADE IN ACCORDANCE WITH "MINIMUM STANDARD DETAIL REQUIREMENTS FOR LAND TITLE SURVEYS".

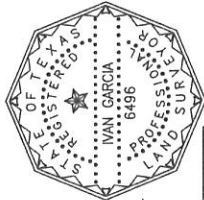

IVAN GARCIA  
 DATE: 8/23/19  
 REG. PROFESSIONAL LAND SURVEYOR NO. 6496

**RIO DELTA ENGINEERING**  
 FIRM REGISTRATION No. F-7628  
 SURVEY FIRM NO. 10194027  
 821 S. 10TH AVENUE, EDINBURG TEXAS 76539  
 (TEL) 956-360-5162 (FAX) 956-360-5083

JULY, 2019  
 SUR 19 059  
 PAGE 1 OF 1

**CENTERLINE OF**  
**STATE HWY 336**  
**(10TH STREET)**

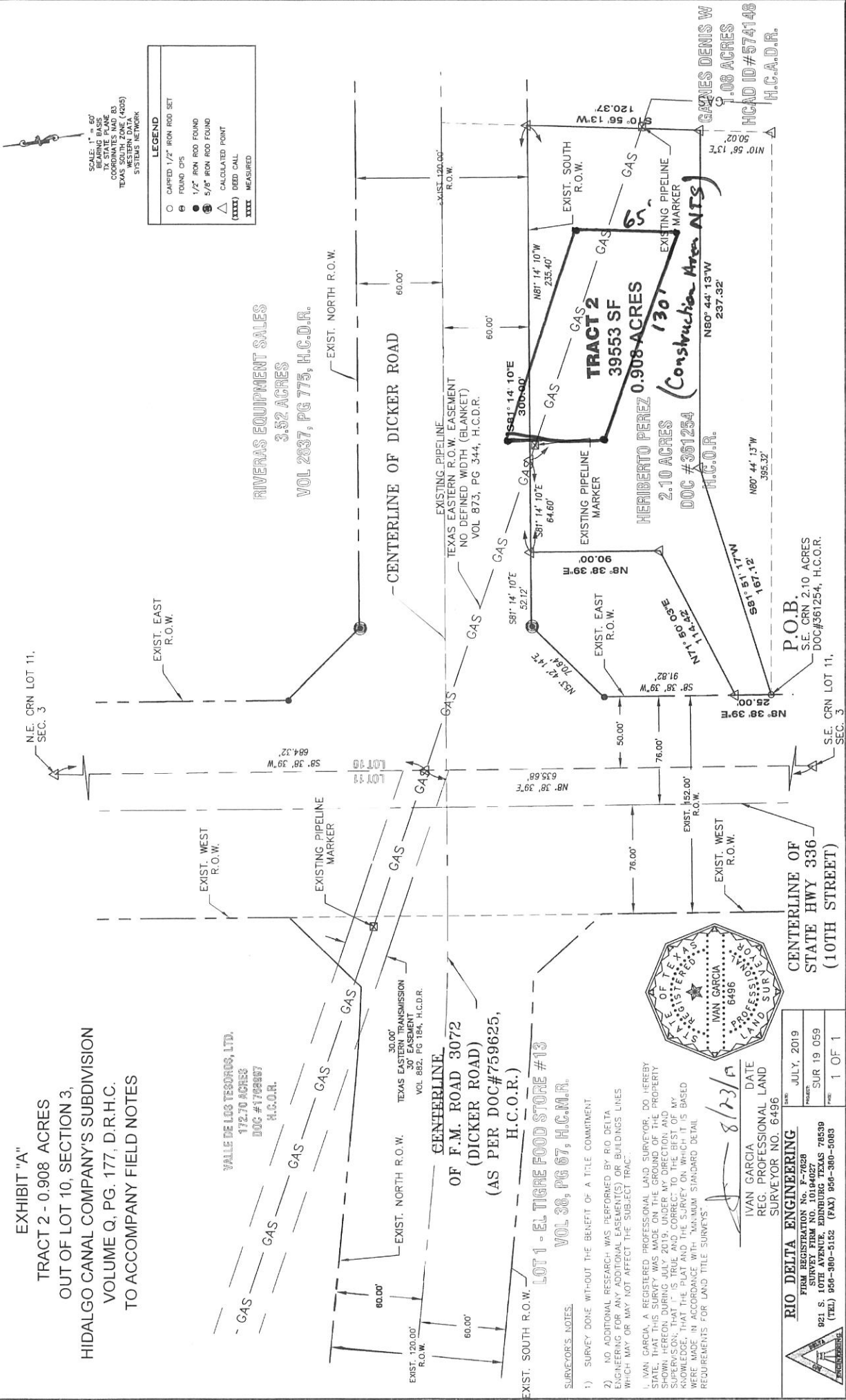

SCALE: 1" = 60'  
 NORTH FROM THE  
 1983 STATE PLANE  
 COORDINATES NAD 83  
 TEXAS WESTERN ZONE (4205)  
 SYSTEMS NETWORK

**LEGEND**

○	CAPPED 1/2" IRON ROD SET
●	FOUND CP'S
⊙	1/2" IRON ROD FOUND
⊗	5/8" IRON ROD FOUND
△	CALCULATED POINT
(XXXX)	REED CALL
XXXX	MEASURED

**RIVERAS EQUIPMENT SALES**  
**3.52 ACRES**  
**VOL 2837, PG 775, H.C.D.R.**

**TRACT 2**  
**39553 SF**  
**0.908 ACRES**  
**HERIBERTO PEREZ**  
**2.10 ACRES**  
**DOC #361254**  
**H.C.O.R.**

**GAMINES DENIS W**  
**0.08 ACRES**  
**H.C.A.D.R.**  
**H.C.A.D.R.**

**P.O.B.**  
**S.E. CRN 210 ACRES**  
**DOC#561254, H.C.O.R.**

## EXHIBIT B

### Additional Conditions to Temporary Easement

Strike Engineering during construction period shall conduct any and all work pertaining to the adjustment of gas line with Lonestar Pipeline Company not to exceed area of 65' x130'. Area has been marked off and will be properly staked.

MEG Engineering, a local Geotechnical engineering firm has been contracted to test the soil at construction site of Mr. Perez's property and confirm the compaction requirements, in addition, the same local engineering firm will be present during backfill to test and confirm compaction is done properly. Excavated soil shall be placed back into the ditch in 6" lifts, compact and test before the next lift is performed.

Temporary easement is scheduled to expire on December 19, 2019. As an agreement between Heriberto Perez and Lonestar any and all work passed November 28, 2019 shall be compensated with the following conditions:

- First week - Any work performed after November 29, 2019 shall be compensated at \$4,000
- Second week – Any work performed shall be compensated at an additional \$4,000
- Third week – Any work performed shall be compensated at an additional \$4,000

This agreement is only permitted if construction work is not completed by the November 28, 2019 deadline.



**INVOICE**

**Invoice:** 022-001120-08  
**Location:** HOUSTON  
**Invoice Date:** 12/23/2019  
**Page No:** Page 1 of 2

**Bill To:** RIO GRANDE INTRASTATE PIPELINE IN TX  
 C/O KINDLE ENERGY  
 500 ALEXANDER RD, SUITE 300  
 PRINCETON, NJ 08540

**Ship To:** RIO GRANDE INTRASTATE PIPELINE IN TX  
 10465 NORTH CONWAY AVENUE  
 MISSION, TX 78573



022-001120-08

Ordered By	Entered By	Location Ref	AFE	Customer PO
MICHELLE	amanda.purcell		DICKER ROAD PROJECT	17MH033-P08001 REV. 0

Work Order	Order Date	FOB	Ship Via	Ship Date
	12/23/2019	SP   PPD & ADD	SEE NOTES	12/23/2019

Line	Item	Quantity Shipped	Quantity Backorder	UOM	Price	Net Total
001	P01R9999 PIPE 8.625" X 0.322" WT, SMLS/ERW, BE, API 5L-PSL2, GR X52, 14 - 16 MILS FBE, 20 MILS ARO, COMPLETE WITH CERTIFIED MILL TESTREPORTS. MUST BE CERTIFIED MADE IN THE USA.	649.80	-	EA	\$ 29.36	\$ 19,078.13
002	EP110561 8-5/8 O.D. SCH 20 .250 WALL 22.38# ERW PIPE A53B/API-5L X52 (PSL-2) DRL BEV FBE 14-16 MIL - TEX-TUBE. MUST BE CERTIFIED MADE IN THE USA.	80.00	-	FT	\$ 19.73	\$ 1,578.40
003	W01C0048 ELL, 45 DEG - 3R, 8", 0.250" WT, BW, MSS-SP-75, Y-42. MUST BE CERTIFIED MADE IN THE USA	4.00	-	EA	\$ 1,341.00	\$ 5,364.00
004	W01C0048 ELL, SEGMENTABLE, 90 DEG - 3R, 8", 0.250" WT, BW, MSS-SP-75, Y-42. MUST BE CERTIFIED MADE IN THE USA	1.00	-	EA	\$ 1,757.78	\$ 1,757.78
005	W01H0015 CAP - 8", 0.250" WT, BW, MSS-SP-75, GR Y-42. MUST BE CERTIFIED MADE IN THE USA.	4.00	-	EA	\$ 133.34	\$ 533.36
006	W01H0015 CAP - 8", 0.322" WT, BW, MSS-SP-75, GR Y-52. MUST BE CERTIFIED MADE IN THE USA	2.00	-	EA	\$ 95.56	\$ 191.12
007	SC000050 HOT SHOT CHARGES FOR ALL MATERIAL	1.00	-	EA	\$ 3,000.00	\$ 3,000.00



**INVOICE**

**Invoice:** 022-001120-08  
**Location:** HOUSTON  
**Invoice Date:** 12/23/2019  
**Page No:** Page 2 of 2

**Bill To:** RIO GRANDE INTRASTATE PIPELINE IN TX  
 C/O KINDLE ENERGY  
 500 ALEXANDER RD, SUITE 300  
 PRINCETON, NJ 08540

**Ship To:** RIO GRANDE INTRASTATE PIPELINE IN TX  
 10465 NORTH CONWAY AVENUE  
 MISSION, TX 78573



022-001120-08

Ordered By	Entered By	Location Ref	AFE	Customer PO
MICHELLE	amanda.purcell		DICKER ROAD PROJECT	17MH033-P08001 REV. 0

Work Order	Order Date	FOB	Ship Via	Ship Date
	12/23/2019	SP   PPD & ADD	SEE NOTES	12/23/2019

Line	Item	Quantity Shipped	Quantity Backorder	UOM	Price	Net Total
------	------	------------------	--------------------	-----	-------	-----------

TAX: 6.25 TX, .5 JIM WELLS COUNTY, 1.5 ALICE- DO NOT USE

TERMS: NET 30 DAYS USD  
 1.5% Per Month (19.56% per Annum)  
 Will be Charged on Overdue Accounts

SubTotal: \$ 31,502.79  
 Sales Tax: \$ 2,598.98

All goods sold are subject to Apex Remington's terms and conditions of sale which are available for your review at <http://www.apexdistribution.com/terms>

NOTES: CREDITING FOR SHIPPING ON LINES 3 & 4 AND THE OVERAGE ON PIPE FOOTAGE FOR LINE 2. APEX BILLING ON 80 FT.

Invoice Total: **\$ 34,101.77**

TxDOT  
 Reimbursable

**Remit To:** Apex Remington, Inc. - Attn AR  
 13505 E 61ST ST  
 STE A  
 BROKEN ARROW, OK 74012  
 Phone: 9188945000  
 Fax: 9183927623

\_\_\_\_\_  
 Signature

\_\_\_\_\_  
 Date



# INVOICE

**Invoice No:** F00174038  
**Invoice Date:** November 22, 2019  
**Payment Terms:** Net 30  
**Contract No:**  
**Reference:** 104-190032: Dicker Road HDD

**Location:** Dicker Road HDD  
**PO:**  
**AFE:**  
**WO:**  
**Other:** 17MH033

**To:** Lonestar Pipeline Company, LLC  
 c/o AP  
 c/o Kindle Energy LLC  
 500 Alexander Park Drive, Suite 300  
 Princeton, New Jersey 08540

**Remit To:** Strike, LLC  
 PO Box 844338  
 Dallas, TX 75284-4338  
  
**Or**  
**Wire:** Bank of America  
 ABA #026009593  
**ACH:** ABA #111000012  
 Strike, LLC  
 Account #4451217749

**Description:** ASSISTED SURVEY CREW WITH MARKING AND LOCATING 8" PIPELINE. PROBED THE LINE ON BOTH ENDS. FINISHED THE TRAFFIC CONTROL SIGNS. AT THE YARD CREW STARTED TO GET SUPPLIES READY FOR TOMORROW'S JOB. PO RENTAL VACTRON. UTILITY LINE LOCATED ON BOTH SIDES OF INTERSECTION ON DICKER AND 10TH ST. WELDERS STARTED TO PREPARE TEST HEADS AND PULL HEADS. LINE LOCATING WITH VAC-TRON. UNCOVERED FOUR UTILITY LINES. MADE TWO TRIPS TO REFILL WITH WATER. LOADED 14 JOINTS OF PIPE TO FLATBED. LOADED SKIDS TO TRAILER. STRUNG OUT ALL 14 JOINTS ON RIGHT OF WAY. WELDERS WELDED ALL BORE LINE. FINISHED THE REST OF THE WELDS AND FINAL CAPS. INSTALLED PIG AND WELDED TEST HEAD. X-RAYED THE WELDS AND GENERAL CLEAN UP. WELDERS STARTED TO FABRICATE OFF SETS AND FITTINGS. ASSISTED PAINTER WITH SANDBLASTING AND COATING. OPERATOR DISCOVERED THE PIPE THAT IS GOING TO BE REMOVED. HYDRO TESTED 8" LINE FOR 4 HOURS. EXPOSED EAST SIDE OF THE START TO BE READY FOR BORING CREW. REMOVED THE WATER IN TO VACUUM TRUCK.

Ticket No.	Ticket Date	Labor	Equipment	Materials	Per Diem	Total
373852	10/29/2019	\$2,552.15	\$580.00	\$0.00	\$0.00	\$3,132.15
373858	11/4/2019	\$0.00	\$0.00	\$2,559.30	\$0.00	\$2,559.30
373860	11/4/2019	\$2,611.48	\$1,036.00	\$0.00	\$0.00	\$3,647.48
373862	11/6/2019	\$1,690.54	\$400.00	\$0.00	\$0.00	\$2,090.54
373867	11/11/2019	\$5,267.96	\$3,166.00	\$624.25	\$0.00	\$9,058.21
373868	11/12/2019	\$5,612.78	\$2,904.00	\$0.00	\$0.00	\$8,516.78
373870	11/13/2019	\$6,426.40	\$3,548.00	\$0.00	\$0.00	\$9,974.40
373871	11/14/2019	\$3,936.84	\$3,184.00	\$0.00	\$290.00	\$7,410.84
373872	11/15/2019	\$3,327.71	\$2,198.00	\$0.00	\$0.00	\$5,525.71
893482	11/15/2019	\$0.00	\$0.00	\$281.03	\$0.00	\$281.03
373873	11/16/2019	\$5,198.24	\$2,438.00	\$0.00	\$0.00	\$7,636.24
		\$36,624.10	\$19,454.00	\$3,464.58	\$290.00	\$59,832.68

<See Next Page>



# INVOICE

<i>Non-taxable Subtotal including any Discounts</i>	\$59,832.68
<i>Taxable Subtotal including any Discounts</i>	\$0.00
<i>Sales Tax :: State Of Texas- 440000000 :: 6.25%</i>	\$0.00
<b>Sales Tax Subtotal</b>	<b>\$0.00</b>

**Total Invoice Due:**

**\$59,832.68**

TxDOT  
Reimbursable

COPY



## INVOICE SUMMARY

### LABOR

Classification Description	Standard Hours	Hourly Rate	Overtime Hours	Overtime Rate	Standard Total	Overtime Total	Surcharge	Labor Total
Craft Helper - B	32.00	\$35.58	17.00	\$49.45	\$1,138.56	\$840.65	\$0.00	\$1,979.21
Craftsman - A	8.00	\$52.99	3.00	\$75.33	\$423.92	\$225.99	\$0.00	\$649.91
Equipment Operator - A	48.00	\$57.74	22.00	\$82.39	\$2,771.52	\$1,812.58	\$0.00	\$4,584.10
Foreman - Craft	8.00	\$62.48	3.00	\$89.45	\$499.84	\$268.35	\$0.00	\$768.19
Quality Associate	11.00	\$54.57	2.00	\$77.69	\$600.27	\$155.38	\$0.00	\$755.65
Skilled Laborer	227.00	\$34.00	93.00	\$47.10	\$7,718.00	\$4,380.30	\$0.00	\$12,098.30
Superintendent B	48.00	\$78.31	21.00	\$112.98	\$3,758.88	\$2,372.58	\$0.00	\$6,131.46
Testing & Cleaning Technician	8.00	\$57.74	2.00	\$82.39	\$461.92	\$164.78	\$0.00	\$626.70
Truck Driver - A (Equipment Operator w/ CDL)	3.00	\$54.57	0.00	\$77.69	\$163.71	\$0.00	\$0.00	\$163.71
Welder - Certified (w/o Rig)	69.00	\$75.15	34.00	\$108.28	\$5,185.35	\$3,681.52	\$0.00	\$8,866.87
<b>Labor Total</b>	<b>462.00</b>		<b>197.00</b>		<b>\$22,721.97</b>	<b>\$13,902.13</b>	<b>\$0.00</b>	<b>\$36,624.10</b>

### EQUIPMENT

Equipment Name	Quantity	Rate	Amount	Surcharge	Equipment Total
Air Compressors - 185 CFM	2.00	\$254.00	\$508.00	\$0.00	\$508.00
Excavator - 20 to 24 Metric Ton - (Machine with Standard Bucket)	62.00	\$99.00	\$6,138.00	\$0.00	\$6,138.00
Rubber Tire Backhoe (Machine with Standard Bucket)	62.00	\$43.00	\$2,666.00	\$0.00	\$2,666.00
Test Cabin/Trailer	1.00	\$650.00	\$650.00	\$0.00	\$650.00
Trailer - Bumper Pull Utility	3.00	\$86.00	\$258.00	\$0.00	\$258.00
Truck - 1 Ton (Double Rear Wheel)	21.00	\$36.00	\$756.00	\$0.00	\$756.00
Truck - 1 Ton (Weld Rig)	103.00	\$36.00	\$3,708.00	\$0.00	\$3,708.00
Truck - 1/2 to 3/4 ton	99.00	\$30.00	\$2,970.00	\$0.00	\$2,970.00
Truck - Contract Operator/Straw Pickup	90.00	\$20.00	\$1,800.00	\$0.00	\$1,800.00
<b>Equipment Total</b>			<b>\$19,454.00</b>	<b>\$0.00</b>	<b>\$19,454.00</b>

### PER DIEM

	Quantity	Rate	Amount	Surcharge	Per Diem Total
	2.00	\$145.00	\$290.00	\$0.00	\$290.00
<b>Per Diem Total</b>			<b>\$290.00</b>	<b>\$0.00</b>	<b>\$290.00</b>

### MATERIAL

Material Name	Mark up	Cost	SalesTax	Amount	Surcharge	Material Total
SECURITY	\$42.87	\$238.16	\$0.00	\$238.16	\$0.00	\$281.03
PIGS AND COATING	\$90.07	\$500.40	\$33.78	\$534.18	\$0.00	\$624.25
VACTRON RENTAL DELIVERY/PICKUP	\$65.92	\$366.22	\$30.14	\$396.36	\$0.00	\$462.28
VACTRON RENTAL	\$544.92	\$1,434.00	\$118.10	\$1,552.10	\$0.00	\$2,097.02
<b>Material Total</b>	<b>\$743.78</b>		<b>\$182.02</b>	<b>\$2,720.80</b>	<b>\$0.00</b>	<b>\$3,464.58</b>

Non-Taxable Subtotal	\$59,832.68
Taxable Subtotal	\$0.00
Sales Tax Subtotal	\$0.00
<b>Total Invoice Due</b>	<b>\$59,832.68</b>



**Daily Labor & Equipment Time Ticket**

Date: 10/29/2019

Ticket No: 373852

Client: Lonestar Pipeline Company, LLC      Location: DICKER RD      Job No: 104-190032.095

Other: 17MH033

ASSISTED SURVEY CREW WITH MARKING AND LOCATING 8" PIPELINE. PROBED THE LINE ON BOTH ENDS. FINISHED THE TRAFFIC CONTROL SIGNS.

AT THE YARD CREW STARTED TO GET SUPPLIES READY FOR TOMORROW'S JOB.

Combo Rate Description	Combo ID	ST Hours	OT Hours	ST Rate	OT Rate	Surcharge	Amount
<b>Subtotal:</b>							<b>\$0.00</b>

Emp No.	Employee Name	Per Diem	Classification	ST Hours	OT Hours	ST Rate	OT Rate	Surcharge	Amount
108210	Rocha, Hernan	No	Superintendent B	8.00	0.00	\$78.31	\$112.98	\$0.00	\$626.48
132411	Rios, Jorge Luis	No	Equipment Operator - A	8.00	0.00	\$57.74	\$82.39	\$0.00	\$461.92
139137	Gonzalez, Miguel	No	Skilled Laborer	8.00	0.00	\$34.00	\$47.10	\$0.00	\$272.00
143660	Cantu, Hector	No	Skilled Laborer	8.00	0.00	\$34.00	\$47.10	\$0.00	\$272.00
147812	Cantu, Norberto	No	Skilled Laborer	8.00	0.00	\$34.00	\$47.10	\$0.00	\$272.00
107287	Cottrell, Brandon Stewart	No	Skilled Laborer	8.00	0.00	\$34.00	\$47.10	\$0.00	\$272.00
122196	Cuate, Arnulfo	No	Welder - Certified (w/o Rig)	5.00	0.00	\$75.15	\$108.28	\$0.00	\$375.75
<b>Subtotal:</b>									<b>\$2,552.15</b>

Number	Per Diem	Rate	Surcharge	Amount
<b>Subtotal:</b>				<b>\$0.00</b>

Equipment Name	Fleet Asset ID	Hours/Day	Rate	PO No	Vendor Name	Surcharge	Amount
Truck - Contract Operator/Straw Pickup		8.00	\$20.00			\$0.00	\$160.00
Truck - 1/2 to 3/4 ton	S19-F1790	8.00	\$30.00			\$0.00	\$240.00
Truck - 1 Ton (Weld Rig)		5.00	\$36.00			\$0.00	\$180.00
<b>Subtotal:</b>							<b>\$580.00</b>

Material Name	Vendor Name	PO No	Cost	Mark Up	Sales Tax	Surcharge	Amount
<b>Subtotal:</b>							<b>\$0.00</b>

Supervisor Signature      X \_\_\_\_\_

Approval Signature      X \_\_\_\_\_

<b>Total:</b>	<b>\$3,132.15</b>
---------------	-------------------

Last Modified: 11/6/2019 4:58:05 PM

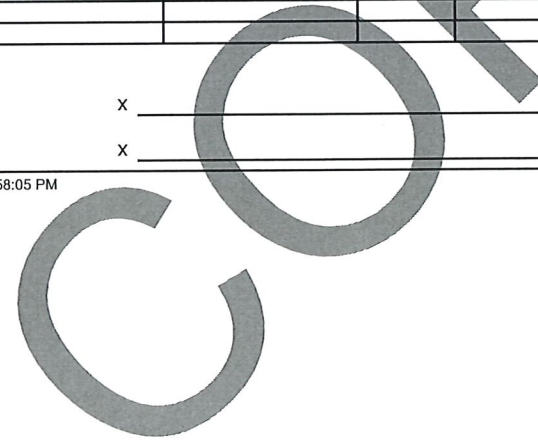





Daily Labor & Equipment Time Ticket

Date: 11/04/2019

Ticket No: 373858

Client Lonestar Pipeline Company, LLC Location: MCALLEN Job No: 104-190032.095

Other: 17MH033

PO RENTAL VACTRON.

Combo Rate Description	Combo ID	ST Hours	OT Hours	ST Rate	OT Rate	Surcharge	Amount
<b>Subtotal:</b>							<b>\$0.00</b>

Emp No.	Employee Name	Per Diem	Classification	ST Hours	OT Hours	ST Rate	OT Rate	Surcharge	Amount
<b>Subtotal:</b>									<b>\$0.00</b>

Number	Per Diem	Rate	Surcharge	Amount
<b>Subtotal:</b>				<b>\$0.00</b>

Equipment Name	Fleet Asset ID	Hours/Day	Rate	PO No	Vendor Name	Surcharge	Amount
<b>Subtotal:</b>							<b>\$0.00</b>

Material Name	Vendor Name	PO No	Cost	Mark Up	Sales Tax	Surcharge	Amount
VACTRON RENTAL	UNITED RENTALS INC	104643309	\$1,434.00	\$544.92	\$118.10	\$0.00	\$2,097.02
VACTRON RENTAL DELIVERY/PICKUP	UNITED RENTALS INC	104643309	\$366.22	\$65.92	\$30.14	\$0.00	\$462.28
<b>Subtotal:</b>							<b>\$2,559.30</b>

Supervisor Signature X \_\_\_\_\_

Approval Signature X \_\_\_\_\_

**Total: \$2,559.30**

Last Modified: 11/13/2019 4:42:26 PM

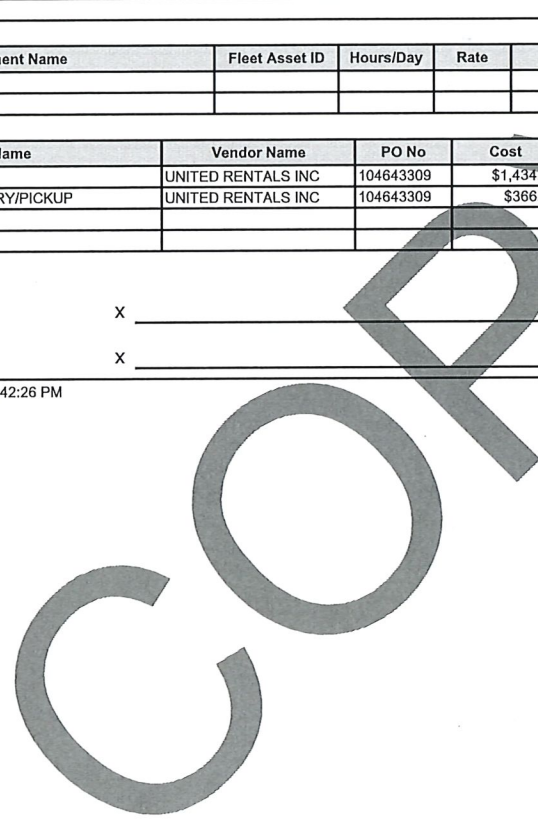





# 175747844-001

BRANCH P49  
3925 N. CAGE BLVD  
PHARR TX 78577-8041  
956-787-9590  
956-702-0621 FAX

Job Site

HIDALGO JOB  
10TH DICKER RD  
x:10TH@DICKER RD  
HIDALGO TX 78557  
Office: 713-389-3235 Cell: 346-334-3981

Customer #	: 1133190
Invoice Date	: 11/06/19
Rental Out	: 11/04/19 09:12 AM
Rental In	: 11/06/19 03:12 PM
UR Job Loc	: 10TH DICKER RD, HIDA
UR Job #	: 2741
Customer Job ID:	
P.O. #	: 104643309
Requested By	: RICARDO GARCIA
Approved By	: ADAM TORRES
Salesperson	: RAUL GONZALEZ JR

STRIKE LLC  
STE 500  
1800 HUGHES LANDING BLVD  
THE WOODLANDS TX 77380-1684

**Invoice Amount: \$1,948.46**

Terms: Net 60 Days  
Payment options: Contact our credit office 704-916-4825  
**REMIT TO:** UNITED RENTALS (NORTH AMERICA),INC.  
PO BOX 840514  
DALLAS TX 75284-0514

RENTAL ITEMS:

Qty	Equipment	Description	Minimum	Day	Week	Month	Amount
1	10602228	VACUUM TRAILER 400-750 GALLON Make: DITCHWITCH Model: FX30 VAC SYSTEM Serial: DWPFX30XPH0003175		478.00	1468.00	3108.00	1,434.00

Rental Subtotal: 1,434.00

SALES/MISCELLANEOUS ITEMS:

Qty	Item	Price	Unit of Measure	Extended Amt.
1	TX UNIT PROPERTY TAX	[DRSURT/MCI] 3.501	EACH	3.50
1	ENVIRONMENTAL SERVICE CHARGE	[ENV/MCI] 28.680	EACH	28.68
1	DELIVERY CHARGE	167.020	EACH	167.02
1	PICKUP CHARGE	167.020	EACH	167.02
Sales/Misc Subtotal:				366.22
Agreement Subtotal:				1,800.22
Tax:				148.24
Total:				1,948.46

COMMENTS/NOTES:

CONTACT: RICARDO GARCIA  
CELL#: 346-334-3981

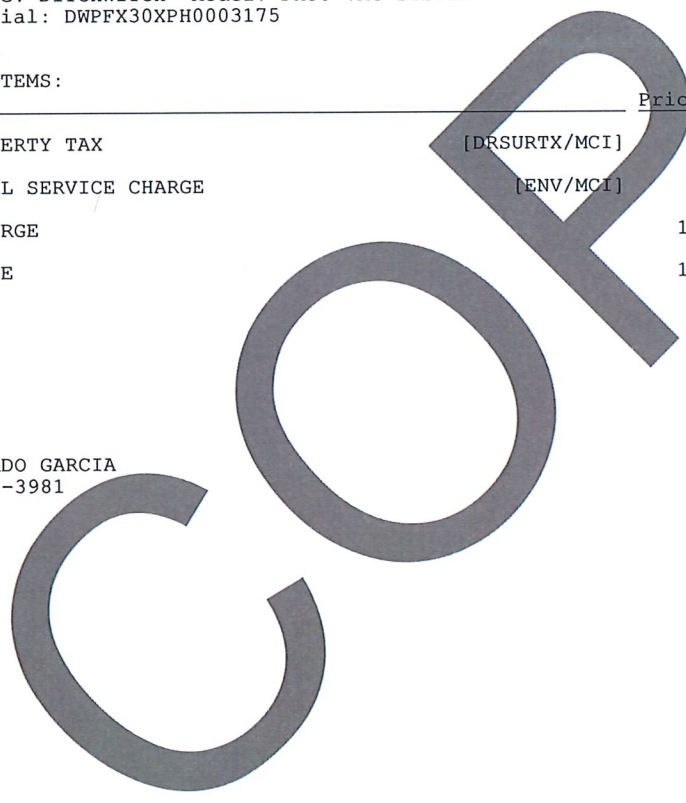



**Daily Labor & Equipment Time Ticket**

Date: 11/04/2019

Ticket No: 373860

Client: Lonestar Pipeline Company, LLC      Location: MCALLEN      Job No: 104-190032.095

Other: 17MH033

UTILITY LINE LOCATED ON BOTH SIDES OF INTERSECTION ON DICKER AND 10TH ST. WELDERS STARTED TO PREPARE TEST HEADS AND PULL HEADS.

Combo Rate Description	Combo ID	ST Hours	OT Hours	ST Rate	OT Rate	Surcharge	Amount
<b>Subtotal:</b>							<b>\$0.00</b>

Emp No.	Employee Name	Per Diem	Classification	ST Hours	OT Hours	ST Rate	OT Rate	Surcharge	Amount
108210	Rocha, Hernan	No	Superintendent B	8.00	2.00	\$78.31	\$112.98	\$0.00	\$852.44
122196	Cuate, Arnulfo	No	Welder - Certified (w/o Rig)	8.00	0.00	\$75.15	\$108.28	\$0.00	\$601.20
136337	Perez, Ivan	No	Welder - Certified (w/o Rig)	8.00	0.00	\$75.15	\$108.28	\$0.00	\$601.20
121491	Arevalo, Heriberto	No	Craft Helper - B	8.00	0.00	\$35.58	\$49.45	\$0.00	\$284.64
131075	Rodriguez, Jose Luis	No	Skilled Laborer	8.00	0.00	\$34.00	\$47.10	\$0.00	\$272.00
<b>Subtotal:</b>									<b>\$2,611.48</b>

Number	Per Diem	Rate	Surcharge	Amount
<b>Subtotal:</b>				<b>\$0.00</b>

Equipment Name	Fleet Asset ID	Hours/Day	Rate	PO No	Vendor Name	Surcharge	Amount
Truck - 1/2 to 3/4 ton	S19-F1790	10.00	\$30.00			\$0.00	\$300.00
Truck - 1 Ton (Weld Rig)		8.00	\$36.00			\$0.00	\$288.00
Truck - 1 Ton (Weld Rig)		8.00	\$36.00			\$0.00	\$288.00
Truck - Contract Operator/Straw Pickup		8.00	\$20.00			\$0.00	\$160.00
<b>Subtotal:</b>							<b>\$1,036.00</b>

Material Name	Vendor Name	PO No	Cost	Mark Up	Sales Tax	Surcharge	Amount
<b>Subtotal:</b>							<b>\$0.00</b>

Supervisor Signature      X \_\_\_\_\_  
 Approval Signature      X \_\_\_\_\_

**Total:      \$3,647.48**

Last Modified: 11/13/2019 4:30:01 PM

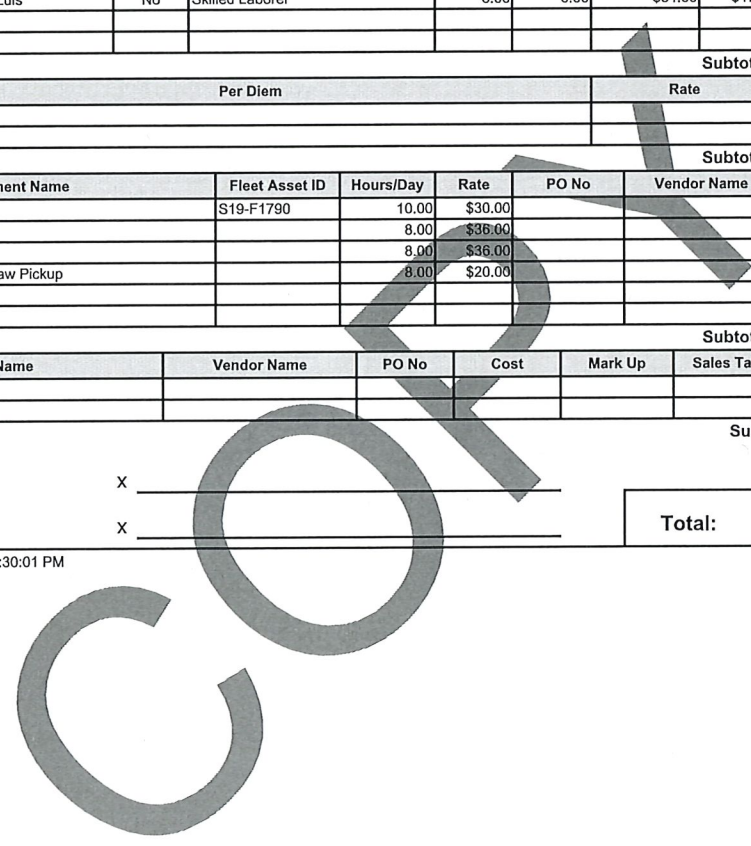





**Daily Labor & Equipment Time Ticket**

Date: 11/06/2019

Ticket No: 373862

**Client** Lonestar Pipeline Company, LLC    **Location:** MCALLEN    **Job No:** 104-190032.095

Other: 17MH033

LINE LOCATING WITH VAC-TRON. UNCOVERED FOUR UTILITY LINES. MADE TWO TRIPS TO REFILL WITH WATER.

Combo Rate Description	Combo ID	ST Hours	OT Hours	ST Rate	OT Rate	Surcharge	Amount

**Subtotal: \$0.00**

Emp No.	Employee Name	Per Diem	Classification	ST Hours	OT Hours	ST Rate	OT Rate	Surcharge	Amount
124660	Garcia, Ricardo	No	Quality Associate	8.00	2.00	\$54.57	\$77.69	\$0.00	\$591.94
131075	Rodriguez, Jose Luis	No	Skilled Laborer	8.00	2.00	\$34.00	\$47.10	\$0.00	\$366.20
143660	Cantu, Hector	No	Skilled Laborer	8.00	2.00	\$34.00	\$47.10	\$0.00	\$366.20
147812	Cantu, Norberto	No	Skilled Laborer	8.00	2.00	\$34.00	\$47.10	\$0.00	\$366.20

**Subtotal: \$1,690.54**

Number	Per Diem	Rate	Surcharge	Amount

**Subtotal: \$0.00**

Equipment Name	Fleet Asset ID	Hours/Day	Rate	PO No	Vendor Name	Surcharge	Amount
Truck - Contract Operator/Straw Pickup		10.00	\$20.00			\$0.00	\$200.00
Truck - Contract Operator/Straw Pickup		10.00	\$20.00			\$0.00	\$200.00

**Subtotal: \$400.00**

Material Name	Vendor Name	PO No	Cost	Mark Up	Sales Tax	Surcharge	Amount

**Subtotal: \$0.00**

Supervisor Signature    X \_\_\_\_\_  
 Approval Signature    X \_\_\_\_\_

**Total: \$2,090.54**

Last Modified: 11/13/2019 4:49:31 PM

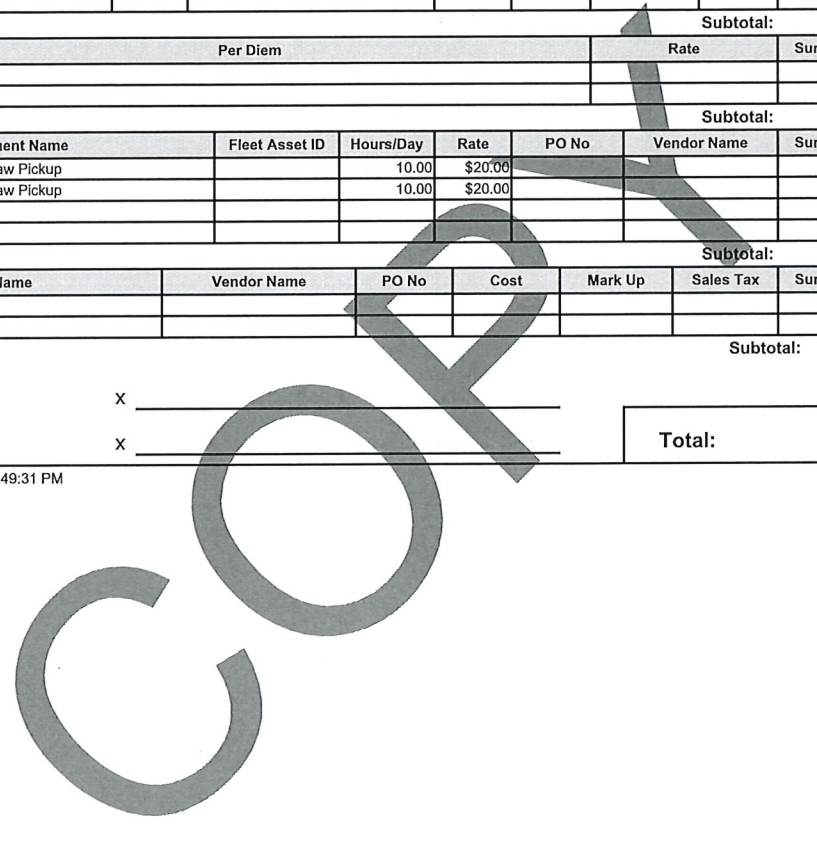





**Daily Labor & Equipment Time Ticket**

Date: 11/11/2019

Ticket No: 373867

Client Lonestar Pipeline Company, LLC Location: MCALLEN Job No: 104-190032.095  
 Other: 17MH033

LOADED 14 JOINTS OF PIPE TO FLATBED. LOADED SKIDS TO TRAILER. STRUNG OUT ALL 14 JOINTS ON RIGHT OF WAY. WELDERS WELDED ALL BORE LINE.

Combo Rate Description	Combo ID	ST Hours	OT Hours	ST Rate	OT Rate	Surcharge	Amount

**Subtotal: \$0.00**

Emp No.	Employee Name	Per Diem	Classification	ST Hours	OT Hours	ST Rate	OT Rate	Surcharge	Amount
108210	Rocha, Hernan	No	Foreman - Craft	8.00	3.00	\$62.48	\$89.45	\$0.00	\$768.19
122614	Salinas, Cesar	No	Equipment Operator - A	8.00	3.00	\$57.74	\$82.39	\$0.00	\$709.09
139137	Gonzalez, Miguel	No	Skilled Laborer	8.00	3.00	\$34.00	\$47.10	\$0.00	\$413.30
143660	Cantu, Hector	No	Skilled Laborer	8.00	3.00	\$34.00	\$47.10	\$0.00	\$413.30
147812	Cantu, Norberto	No	Skilled Laborer	8.00	3.00	\$34.00	\$47.10	\$0.00	\$413.30
122196	Cuate, Arnulfo	No	Welder - Certified (w/o Rig)	8.00	3.00	\$75.15	\$108.28	\$0.00	\$926.04
136337	Perez, Ivan	No	Welder - Certified (w/o Rig)	8.00	3.00	\$75.15	\$108.28	\$0.00	\$926.04
121491	Arevalo, Heriberto	No	Craft Helper - B	8.00	3.00	\$35.58	\$49.45	\$0.00	\$432.99
147005	Alanis, Jesus Adrian	No	Truck Driver - A (Equipment Operator)	3.00	0.00	\$54.57	\$77.69	\$0.00	\$163.71
121847	Salinas Garcia, Saturnino	No	Skilled Laborer	3.00	0.00	\$34.00	\$47.10	\$0.00	\$102.00

**Subtotal: \$5,267.96**

Number	Per Diem	Rate	Surcharge	Amount

**Subtotal: \$0.00**

Equipment Name	Fleet Asset ID	Hours/Day	Rate	PO No	Vendor Name	Surcharge	Amount
Truck - 1 Ton (Weld Rig)		11.00	\$36.00			\$0.00	\$396.00
Truck - 1 Ton (Weld Rig)		11.00	\$36.00			\$0.00	\$396.00
Truck - 1/2 to 3/4 ton	S19-F1790	11.00	\$30.00			\$0.00	\$330.00
Truck - 1 Ton (Double Rear Wheel)	S19-F1956	11.00	\$36.00			\$0.00	\$396.00
Excavator - 20 to 24 Metric Ton - (Machine with Standard	S19-EX982	11.00	\$89.00			\$0.00	\$1,089.00
Rubber Tire Backhoe (Machine with Standard Bucket)	C08-BL114	11.00	\$43.00			\$0.00	\$473.00
Trailer - Bumper Pull Utility	S12-AT190	1.00	\$86.00			\$0.00	\$86.00

**Subtotal: \$3,166.00**

Material Name	Vendor Name	PO No	Cost	Mark Up	Sales Tax	Surcharge	Amount
PIGS AND COATING	PIPELINE SUPPLY &	104645157	\$500.40	\$90.07	\$33.78	\$0.00	\$624.25

**Subtotal: \$624.25**

Supervisor Signature X \_\_\_\_\_  
 Approval Signature X \_\_\_\_\_

**Total: \$9,058.21**

Date: 11 11 19 Ticket No: 373867  
 Job No: 104-190032-95 City: McAllen  
 Client Name: Lonestar Location Site Name: McAllen County: Hidalgo  
 Project Name: Dicker Rd AFE PID: P017MH033 State: TX



Description of Work  
Loaded 14 joints of pipe to flatbed, loaded skids to trailer  
Strung out all 14 joints on right away, welders welded all of bond  
line.

Emp. No.	Employee Name	Classification	ST Hrs	OT Hrs	P.Diem	L.Rent	Amount
108210	Herman Rocha	Supt	8				
122614	Cesar Salinas	Operator	8				
139137	Miguel Gonzalez	S labor	8				
143660	Hector Cantu	S labor	8				
147812	Herberto Cantu	S labor	8				
122196	Arnulfo Cantu	welder	8			1	
136337	Ivan Perez	welder	8			1	
121491	Herberto Arnaldo	welder/helper	8				
147005	Jesus Alaniz	Driver	3				
121847	Sturnino Salinas	S labor	3				
Subtotal							

Equipment Description	Unit No.	Hours/Days	Amount
welding rig	Arnulfo Cantu	11	
welding rig	Ivan Perez	11	
3/4 ton truck w/tool	519-F1790	11	
3/4 ton truck	519-F1756	11	
excavator Deere	519-EX982	11	
Backhoe Cat	608-B114	11	
utility trailer 20'	512-At190	1 Day	
Subtotal			

Material/Subs/Rental Desc.	Vendor	Inv. No.	PO#	Amount
Pigs and paint	PSS		104645157	
Subtotal				

Supervisor Signature X [Signature]  
 Approval Signature X [Signature]  
 Total



# INVOICE

Invoice No.	Invoice Date	Page #
2207325-00	11/13/19	1
PO #	PO Date	
104645157	11/12/19	

Pipeline Supply & Service  
 3084 I-37N Access Road  
 Three Rivers, TX 78071  
 (361)449-1651

Cust # 20105711

<i>Bill To</i>	<i>Ship To</i>
<b>STRIKE CONSTRUCTION</b> <b>1800 HUGHES LANDING BLVD.</b> <b>SUITE 500</b> <b>THE WOODLANDS, TX 77380</b>	<b>STRIKE CONSTRUCTION</b> <b>3084 N. I-37 ACCESS ROAD</b> <b>THREE RIVERS, TX 78071</b>

<i>Placed By</i>	<i>Instructions</i>	<i>Warehouse</i>	<i>Ship Via</i>	<i>Ship Date</i>	<i>Terms</i>
RICARDO		Three Rivers, TX	WILL CALL	11/13/19	Net 60

Ln #	Product And Description	Quantity Ordered	Quantity B/O	Quantity Shipped	Qty UM	Unit Price	Amount (Net)
1	DNS7200 EPOXY DENSO 7200 1 LT KIT *Limited Quantity _____ lbs.	12	0	12	kit	28.08	336.96
2	PIG5B-8 PIG 8" squeegee drying	12	0	12	each	13.62	163.44

2	<i>Lines Total</i>	<i>Qty Shipped Total</i>	24	<b>Total</b>	500.40
				<b>Taxes</b>	33.78
				<b>Invoice Total</b>	<b>\$534.18 USD</b>

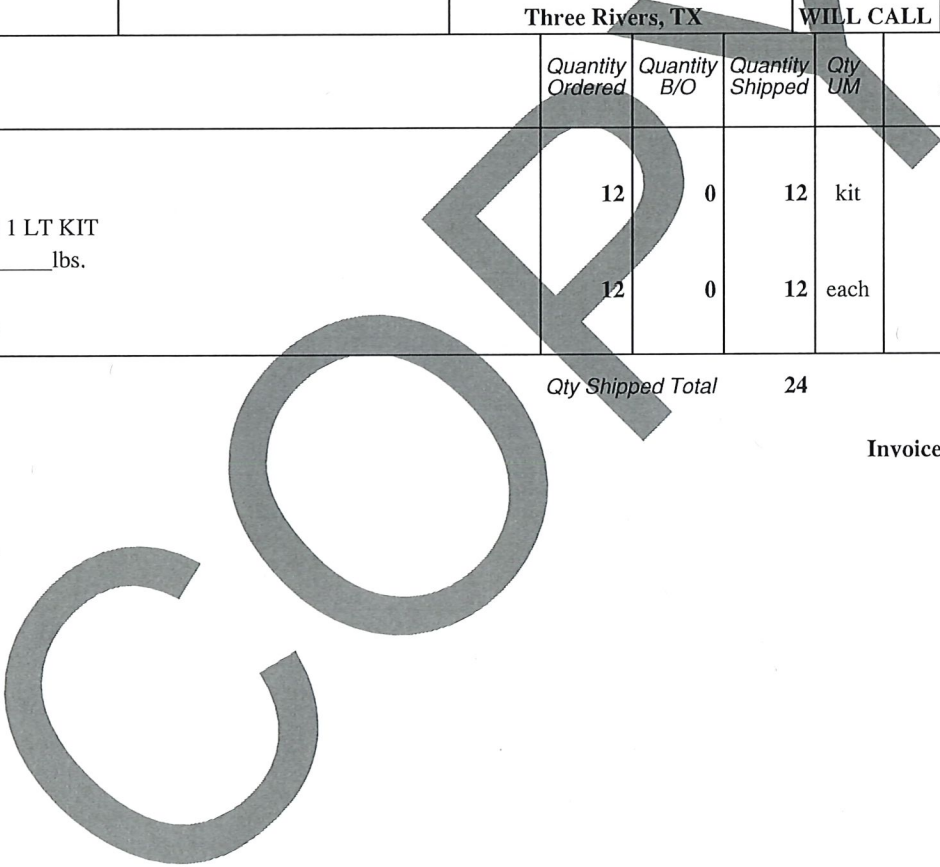

# INVOICE

<i>Remit To</i>
Pipeline Supply & Service PO Box 74321 CLEVELAND, OH 44194-4321

SEE PIPELINESUPPLY.COM FOR CONDITIONS

<i>Invoice Number</i>
2207325-00



**Daily Labor & Equipment Time Ticket**

Date: 11/12/2019

Ticket No: 373868

Client: Lonestar Pipeline Company, LLC Location: MCALLEN Job No: 104-190032.095

Other: 17MH033

FINISHED THE REST OF THE WELDS AND FINAL CAPS. INSTALLED PIG AND WELDED TEST HEAD. X-RAYED THE WELDS AND GENERAL CLEAN UP.

Combo Rate Description	Combo ID	ST Hours	OT Hours	ST Rate	OT Rate	Surcharge	Amount

**Subtotal: \$0.00**

Emp No.	Employee Name	Per Diem	Classification	ST Hours	OT Hours	ST Rate	OT Rate	Surcharge	Amount
108210	Rocha, Hernan	No	Superintendent B	8.00	3.00	\$78.31	\$112.98	\$0.00	\$965.42
132411	Rios, Jorge Luis	No	Equipment Operator - A	8.00	3.00	\$57.74	\$82.39	\$0.00	\$709.09
107287	Cottrell, Brandon Stewart	No	Skilled Laborer	8.00	3.00	\$34.00	\$47.10	\$0.00	\$413.30
139137	Gonzalez, Miguel	No	Skilled Laborer	8.00	3.00	\$34.00	\$47.10	\$0.00	\$413.30
147812	Cantu, Norberto	No	Skilled Laborer	8.00	3.00	\$34.00	\$47.10	\$0.00	\$413.30
143660	Cantu, Hector	No	Skilled Laborer	8.00	3.00	\$34.00	\$47.10	\$0.00	\$413.30
122196	Cuate, Arnulfo	No	Welder - Certified (w/o Rig)	8.00	3.00	\$75.15	\$108.28	\$0.00	\$926.04
136337	Perez, Ivan	No	Welder - Certified (w/o Rig)	8.00	3.00	\$75.15	\$108.28	\$0.00	\$926.04
121491	Arevalo, Heriberto	No	Craft Helper - B	8.00	3.00	\$35.58	\$49.45	\$0.00	\$432.99

**Subtotal: \$5,612.78**

Number	Per Diem	Rate	Surcharge	Amount

**Subtotal: \$0.00**

Equipment Name	Fleet Asset ID	Hours/Day	Rate	PO No	Vendor Name	Surcharge	Amount
Truck - Contract Operator/Straw Pickup		11.00	\$20.00			\$0.00	\$220.00
Truck - 1 Ton (Weld Rig)		11.00	\$36.00			\$0.00	\$396.00
Truck - 1 Ton (Weld Rig)		11.00	\$36.00			\$0.00	\$396.00
Truck - 1/2 to 3/4 ton	S19-F1790	11.00	\$30.00			\$0.00	\$330.00
Excavator - 20 to 24 Metric Ton - (Machine with Standard	S19-EX982	11.00	\$99.00			\$0.00	\$1,089.00
Rubber Tire Backhoe (Machine with Standard Bucket)	C08-BL114	11.00	\$43.00			\$0.00	\$473.00

**Subtotal: \$2,904.00**

Material Name	Vendor Name	PO No	Cost	Mark Up	Sales Tax	Surcharge	Amount

**Subtotal: \$0.00**

Supervisor Signature  \_\_\_\_\_

Approval Signature  \_\_\_\_\_

**Total: \$8,516.78**

Last Modified: 11/20/2019 4:32:48 PM

Date: 11-12-19 Ticket No: 373868  
 Job No: 104-19032-95 City: McAllen  
 Client Name: Lonistar Location/Site Name: McAllen County: Hidalgo  
 Project Name: Dicker Rd AFE/PID: PD: 17mH033 State: TX



Description of Work  
 finished the rest of the welds and final caps. installed pig and welded test head. XRayed the welds and General clean up.

Emp. No.	Employee Name	Classification	ST Hrs	OT Hrs	P/Diem	T/Rent	Amount
108110	Hernan Rocha	Supt B	8	0			
132411	Jorge Rios	Operator	8	3			
107287	Brandon Cattel	Slabor	8	3		7	
134137	Miguel Gonzalez	Slabor	8	3			
147812	Noberto Cantu	Slabor	8	3			
143068	Hector Cantu	Slabor	8	3			
172146	Arnulfo Cuate	welder	8	3		7	
136337	Ivan Perez	welder	8	3		7	
12141	Herberto Aravalo	welder/helper	8	3			

Equipment Description	Unit No.	Subtotal	Amount
3/4 ton truck			
welding rig	Jorge Rios	11	
welding rig	Arnulfo Cuate	11	
3/4 ton truck w/tools	Ivan Perez	11	
excavator Deere	S19-F1790	11	
Backhee Cat	S19-EX987	11	
	CO8-BL114	11	

Material/Subs/Rental Desc.	Vendor	Inv. No.	PO#	Subtotal	Amount

Supervisor Signature X

Approval Signature X

Total



**Daily Labor & Equipment Time Ticket**

Date: 11/13/2019

Ticket No: 373870

Client: Lonestar Pipeline Company, LLC Location: MCALLEN Job No: 104-190032.095

Other: 17MH033

WELDERS STARTED TO FABRICATE OFF SETS AND FITTINGS. ASSISTED PAINTER WITH SANDBLASTING AND COATING. OPERATOR DISCOVERED THE PIPE THAT IS GOING TO BE REMOVED.

Combo Rate Description	Combo ID	ST Hours	OT Hours	ST Rate	OT Rate	Surcharge	Amount

**Subtotal: \$0.00**

Emp No.	Employee Name	Per Diem	Classification	ST Hours	OT Hours	ST Rate	OT Rate	Surcharge	Amount
108210	Rocha, Hernan	No	Superintendent B	8.00	3.00	\$78.31	\$112.98	\$0.00	\$965.42
132411	Rios, Jorge Luis	No	Equipment Operator - A	8.00	3.00	\$57.74	\$82.39	\$0.00	\$709.09
107287	Cottrell, Brandon Stewart	No	Skilled Laborer	8.00	3.00	\$34.00	\$47.10	\$0.00	\$413.30
143660	Cantu, Hector	No	Skilled Laborer	8.00	3.00	\$34.00	\$47.10	\$0.00	\$413.30
147812	Cantu, Norberto	No	Skilled Laborer	8.00	3.00	\$34.00	\$47.10	\$0.00	\$413.30
139137	Gonzalez, Miguel	No	Skilled Laborer	8.00	3.00	\$34.00	\$47.10	\$0.00	\$413.30
139597	Molina, Amado	No	Craftsman - A	8.00	3.00	\$52.99	\$75.33	\$0.00	\$649.91
122196	Cuate, Arnulfo	No	Welder - Certified (w/o Rig)	8.00	3.00	\$75.15	\$108.28	\$0.00	\$926.04
136337	Perez, Ivan	No	Welder - Certified (w/o Rig)	8.00	3.00	\$75.15	\$108.28	\$0.00	\$926.04
121491	Arevalo, Heriberto	No	Craft Helper - B	8.00	3.00	\$35.58	\$49.45	\$0.00	\$432.99
124660	Garcia, Ricardo	No	Quality Associate	3.00	0.00	\$54.57	\$77.69	\$0.00	\$163.71

**Subtotal: \$6,426.40**

Number	Per Diem	Rate	Surcharge	Amount

**Subtotal: \$0.00**

Equipment Name	Fleet Asset ID	Hours/Day	Rate	PO No	Vendor Name	Surcharge	Amount
Truck - Contract Operator/Straw Pickup		11.00	\$20.00			\$0.00	\$220.00
Truck - 1 Ton (Weld Rig)		11.00	\$36.00			\$0.00	\$396.00
Truck - 1 Ton (Weld Rig)		11.00	\$36.00			\$0.00	\$396.00
Truck - 1/2 to 3/4 ton	S19-F1790	11.00	\$30.00			\$0.00	\$330.00
Truck - 1/2 to 3/4 ton	S19-F1732	11.00	\$30.00			\$0.00	\$330.00
Air Compressors - 185 CFM	S18-AC240	1.00	\$254.00			\$0.00	\$254.00
Excavator - 20 to 24 Metric Ton - (Machine with Standard	S19-EX982	11.00	\$99.00			\$0.00	\$1,099.00
Rubber Tire Backhoe (Machine with Standard Bucket)	C08-BL114	11.00	\$43.00			\$0.00	\$473.00
Truck - Contract Operator/Straw Pickup		3.00	\$20.00			\$0.00	\$60.00

**Subtotal: \$3,548.00**

Material Name	Vendor Name	PO No	Cost	Mark Up	Sales Tax	Surcharge	Amount

**Subtotal: \$0.00**

Supervisor Signature: \_\_\_\_\_ X \_\_\_\_\_

Approval Signature: \_\_\_\_\_ X \_\_\_\_\_

**Total: \$9,974.40**





**Daily Labor & Equipment Time Ticket**

Date: 11/14/2019

Ticket No: 373871

Client: Lonestar Pipeline Company, LLC Location: HIDALGO Job No: 104-190032.095

Other: 17MH033

HYDRO TESTED 8" LINE FOR 4 HOURS. EXPOSED EAST SIDE OF THE START TO BE READY FOR BORING CREW. REMOVED THE WATER IN TO VACUUM TRUCK. APPLIED SECOND COAT OF PAINT TO WELDS.

Combo Rate Description	Combo ID	ST Hours	OT Hours	ST Rate	OT Rate	Surcharge	Amount

**Subtotal: \$0.00**

Emp No.	Employee Name	Per Diem	Classification	ST Hours	OT Hours	ST Rate	OT Rate	Surcharge	Amount
108210	Rocha, Hernan	No	Superintendent B	8.00	2.00	\$78.31	\$112.98	\$0.00	\$852.44
132411	Rios, Jorge Luis	No	Equipment Operator - A	8.00	2.00	\$57.74	\$82.39	\$0.00	\$626.70
107287	Cottrell, Brandon Stewart	No	Skilled Laborer	8.00	2.00	\$34.00	\$47.10	\$0.00	\$366.20
143660	Cantu, Hector	No	Skilled Laborer	8.00	2.00	\$34.00	\$47.10	\$0.00	\$366.20
147812	Cantu, Norberto	No	Skilled Laborer	8.00	2.00	\$34.00	\$47.10	\$0.00	\$366.20
139137	Gonzalez, Miguel	No	Skilled Laborer	8.00	2.00	\$34.00	\$47.10	\$0.00	\$366.20
130360	Richard, Glenn D	Yes	Testing & Cleaning Technician	8.00	2.00	\$57.74	\$82.39	\$0.00	\$626.70
147847	Duhon, Braxton Cade	Yes	Skilled Laborer	8.00	2.00	\$34.00	\$47.10	\$0.00	\$366.20

**Subtotal: \$3,936.84**

Number	Per Diem	Rate	Surcharge	Amount
2	Per Diem	\$145.00	\$0.00	\$290.00

**Subtotal: \$290.00**

Equipment Name	Fleet Asset ID	Hours/Day	Rate	PO No	Vendor Name	Surcharge	Amount
Truck - Contract Operator/Straw Pickup		10.00	\$20.00			\$0.00	\$200.00
Truck - 1/2 to 3/4 ton	S19-F1790	10.00	\$30.00			\$0.00	\$300.00
Excavator - 20 to 24 Metric Ton - (Machine with Standard	S19-EX982	10.00	\$99.00			\$0.00	\$990.00
Rubber Tire Backhoe (Machine with Standard Bucket)	C08-BL114	10.00	\$43.00			\$0.00	\$430.00
Air Compressors - 185 CFM	S18-AC240	1.00	\$254.00			\$0.00	\$254.00
Truck - 1 Ton (Double Rear Wheel)	S19-F1959	10.00	\$36.00			\$0.00	\$360.00
Test Cabin/Trailer	S08-PC6	1.00	\$650.00			\$0.00	\$650.00

**Subtotal: \$3,184.00**

Material Name	Vendor Name	PO No	Cost	Mark Up	Sales Tax	Surcharge	Amount

**Subtotal: \$0.00**

Supervisor Signature  \_\_\_\_\_  
 Approval Signature  \_\_\_\_\_

**Total: \$7,410.84**

Last Modified: 11/21/2019 9:19:02 AM

Date: 11 / 14 / 19 Ticket No: 373871  
 Job No: 104-190032-95  City: Hidalgo  
 Client Name: Lonestar Location/Site Name: Hidalgo County: Hidalgo  
 Project Name: Dicker Rd AFE/PID: PO:11mh033 State: TX

Description of Work  
Hydro tested 8" line for 4 hrs, exposed east side of the street to be read for boring crew. Removed to water in to vac truck. Applied second coat of paint to welds

Emp. No.	Employee Name	Classification	ST Hrs	OT Hrs	P/Diem	T/Rent	Amount
109210	Hernan Rocha	Supt B	8	2			
132411	Jorge Rios	Operator	8	2		✓	
107787	Brandon Cottrel	S labor	8	2			
143660	Hector Cantu	S labor	8	2			
147912	Norberto Cantu	S labor	8	2			
139137	Miguel Gonzalez	S labor	8	2			
130360	Glen Richards	Hydro Tester	8	2		✓	
147947	Braxton Duhon	S labor	8	2		✓	
Subtotal							

Equipment Description	Unit No.	Hours/Days	Amount
3/4 ton truck	Jorge Rios	10	
3/4 ton truck w/tool	S19-F1790	10	
Excavator Deere	S19-EX98Z	10	
Backhoe Cat	C08-BL114	10	
air compressor	S18-AC240	10day	
3/4 ton truck	S19-F1959	10	
test trailer	S08-PC6	10day	
Subtotal			

Material/Subs/Rental Desc.	Vendor	Inv. No.	PO#	Amount
Subtotal				

Supervisor Signature X [Signature]  
 Approval Signature X [Signature]  
 Total



**Daily Labor & Equipment Time Ticket**

Date: 11/15/2019

Ticket No: 373872

Client: Lonestar Pipeline Company, LLC    Location: HIDALGO    Job No: 104-190032.095

Other: 17MH033

INSTALLED ALL TRAFFIC CONTROL SIGNS AND GETTING READY WITH COP. SET THE BORE MACHINE ON THE START POINT. PICKED UP ALL SKIDS AND STARTED TO PULL PIPE INSIDE BORE.

Combo Rate Description	Combo ID	ST Hours	OT Hours	ST Rate	OT Rate	Surcharge	Amount

**Subtotal: \$0.00**

Emp No.	Employee Name	Per Diem	Classification	ST Hours	OT Hours	ST Rate	OT Rate	Surcharge	Amount
108210	Rocha, Hernan	No	Superintendent B	8.00	3.00	\$78.31	\$112.98	\$0.00	\$965.42
132411	Rios, Jorge Luis	No	Equipment Operator - A	8.00	3.00	\$57.74	\$82.39	\$0.00	\$709.09
107287	Cottrell, Brandon Stewart	No	Skilled Laborer	8.00	3.00	\$34.00	\$47.10	\$0.00	\$413.30
143660	Cantu, Hector	No	Skilled Laborer	8.00	3.00	\$34.00	\$47.10	\$0.00	\$413.30
147812	Cantu, Norberto	No	Skilled Laborer	8.00	3.00	\$34.00	\$47.10	\$0.00	\$413.30
139137	Gonzalez, Miguel	No	Skilled Laborer	8.00	3.00	\$34.00	\$47.10	\$0.00	\$413.30

**Subtotal: \$3,327.71**

Number	Per Diem	Rate	Surcharge	Amount

**Subtotal: \$0.00**

Equipment Name	Fleet Asset ID	Hours/Day	Rate	PO No	Vendor Name	Surcharge	Amount
Truck - Contract Operator/Straw Pickup		11.00	\$20.00			\$0.00	\$220.00
Truck - 1/2 to 3/4 ton	S19-F1790	11.00	\$30.00			\$0.00	\$330.00
Excavator - 20 to 24 Metric Ton - (Machine with Standard	S19-EX982	11.00	\$99.00			\$0.00	\$1,089.00
Rubber Tire Backhoe (Machine with Standard Bucket)	C08-BL114	11.00	\$43.00			\$0.00	\$473.00
Trailer - Bumper Pull Utility	S12-AT190	1.00	\$86.00			\$0.00	\$86.00

**Subtotal: \$2,198.00**

Material Name	Vendor Name	PO No	Cost	Mark Up	Sales Tax	Surcharge	Amount

**Subtotal: \$0.00**

Supervisor Signature    X \_\_\_\_\_

Approval Signature    X \_\_\_\_\_

**Total: \$5,525.71**

Last Modified: 11/21/2019 9:38:31 AM





**Daily Labor & Equipment Time Ticket**

Date: 11/15/2019 Ticket No: 893482

Client Lonestar Pipeline Company, LLC Location: HIDALGO Job No: 104-190032.095

Other: 17MH033

SENTRY ON SITE SECURITY.

Combo Rate Description	Combo ID	ST Hours	OT Hours	ST Rate	OT Rate	Surcharge	Amount
<b>Subtotal:</b>							<b>\$0.00</b>

Emp No.	Employee Name	Per Diem	Classification	ST Hours	OT Hours	ST Rate	OT Rate	Surcharge	Amount
<b>Subtotal:</b>									<b>\$0.00</b>

Number	Per Diem	Rate	Surcharge	Amount
<b>Subtotal:</b>				<b>\$0.00</b>

Equipment Name	Fleet Asset ID	Hours/Day	Rate	PO No	Vendor Name	Surcharge	Amount
<b>Subtotal:</b>							<b>\$0.00</b>

Material Name	Vendor Name	PO No	Cost	Mark Up	Sales Tax	Surcharge	Amount
SECURITY	SENTRY ON SITE	104646569	\$238.16	\$42.87	\$0.00	\$0.00	\$281.03
<b>Subtotal:</b>							<b>\$281.03</b>

Supervisor Signature	X		<b>Total:</b>	<b>\$281.03</b>
Approval Signature	X			

Last Modified: 11/21/2019 9:38:04 AM

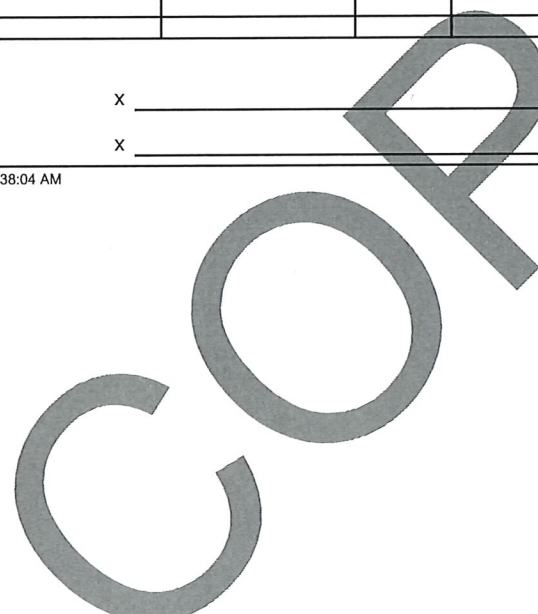



# SENTRY

**Sentry On-site Security Corp.**  
 107 W Lufkin Avenue, Suite 203  
 Lufkin, Texas 75904

**STRIKE, LLC**

1800 Hughes Landing Blvd. Ste 500  
 The Woodlands, Texas 77380

Services Ordered By: Joel K. Sims

## INVOICE

JOB #  
00-0000

DATE OF INVOICE: Monday, 11/18/19

INVOICE NUMBER: SOS-10TH-S001

PURCHASE ORDER # 104646569

**SERVICE DESCRIPTION**

Provide Traffic Control Officer for Strike.  
 Intersection of Dicker Road / 10th Street

**Project Location:** Hidalgo County, Texas

DAY	DATE	SERVICE PROVIDED	JOB-SITE LOCATION	Qty/Hrs	RATE	AMOUNT
<b>Mon</b>	11/11/19					\$ -
<b>Daily Total:</b>	0.00					\$ -
						\$ -
						\$ -
<b>Tues</b>	11/12/19					\$ -
<b>Daily Total:</b>	0.00					\$ -
						\$ -
						\$ -
<b>Wed</b>	11/13/19					\$ -
<b>Daily Total:</b>	0.00					\$ -
						\$ -
						\$ -
<b>Thurs</b>	11/14/19					\$ -
<b>Daily Total:</b>	0.00					\$ -
						\$ -
						\$ -
<b>Fri</b>	11/15/19	1. Traffic Control	Dicker Rd @ 10th Street	04.00	\$59.54	\$ 238.16
<b>Daily Total:</b>	4.00					\$ -
						\$ -
						\$ -
<b>Sat</b>	11/16/19					\$ -
<b>Daily Total:</b>	0.00					\$ -
						\$ -
						\$ -
<b>Sun</b>	11/17/19					\$ -
<b>Daily Total:</b>	0.00					\$ -
						\$ -

TRAFFIC	4.00
POLICE	0.00
GUARD	0.00
<b>Total Hours:</b>	4.00

Subtotal: \$ 238.16  
**TOTAL: \$ 238.16**  
 State sales tax included (if applicable)

**Thank you for your business!**



Daily Labor & Equipment Time Ticket

Date: 11/16/2019

Ticket No: 373873

Client Lonestar Pipeline Company, LLC Location: HIDALGO Job No: 104-190032.095

Other: 17MH033

REPAIRED PIPE WITH COATING. ASSISTED BORE CREW WITH PULLING PIPE IN TO THE BORE HOLE.

Combo Rate Description	Combo ID	ST Hours	OT Hours	ST Rate	OT Rate	Surcharge	Amount

Subtotal: \$0.00

Emp No.	Employee Name	Per Diem	Classification	ST Hours	OT Hours	ST Rate	OT Rate	Surcharge	Amount
108210	Rocha, Hernan	No	Superintendent B	0.00	8.00	\$78.31	\$112.98	\$0.00	\$903.84
132411	Rios, Jorge Luis	No	Equipment Operator - A	0.00	8.00	\$57.74	\$82.39	\$0.00	\$659.12
107287	Cottrell, Brandon Stewart	No	Skilled Laborer	0.00	8.00	\$34.00	\$47.10	\$0.00	\$376.80
143660	Cantu, Hector	No	Skilled Laborer	0.00	8.00	\$34.00	\$47.10	\$0.00	\$376.80
147812	Cantu, Norberto	No	Skilled Laborer	0.00	8.00	\$34.00	\$47.10	\$0.00	\$376.80
139137	Gonzalez, Miguel	No	Skilled Laborer	0.00	8.00	\$34.00	\$47.10	\$0.00	\$376.80
122196	Cuate, Arnulfo	No	Welder - Certified (w/o Rig)	0.00	8.00	\$75.15	\$108.28	\$0.00	\$866.24
136337	Perez, Ivan	No	Welder - Certified (w/o Rig)	0.00	8.00	\$75.15	\$108.28	\$0.00	\$866.24
121491	Arevalo, Heriberto	No	Craft Helper - B	0.00	8.00	\$35.58	\$49.45	\$0.00	\$395.60

Subtotal: \$5,198.24

Number	Per Diem	Rate	Surcharge	Amount

Subtotal: \$0.00

Equipment Name	Fleet Asset ID	Hours/Day	Rate	PO No	Vendor Name	Surcharge	Amount
Truck - Contract Operator/Straw Pickup		8.00	\$20.00			\$0.00	\$160.00
Truck - 1 Ton (Weld Rig)		8.00	\$36.00			\$0.00	\$288.00
Truck - 1 Ton (Weld Rig)		8.00	\$36.00			\$0.00	\$288.00
Truck - 1/2 to 3/4 ton	S19-F1790	8.00	\$30.00			\$0.00	\$240.00
Truck - 1/2 to 3/4 ton	S12-F447	8.00	\$30.00			\$0.00	\$240.00
Excavator - 20 to 24 Metric Ton - (Machine with Standard	S19-EX982	8.00	\$99.00			\$0.00	\$792.00
Rubber Tire Backhoe (Machine with Standard Bucket)	C08-BL114	8.00	\$43.00			\$0.00	\$344.00
Trailer - Bumper Pull Utility	S12-AT190	1.00	\$86.00			\$0.00	\$86.00

Subtotal: \$2,438.00

Material Name	Vendor Name	PO No	Cost	Mark Up	Sales Tax	Surcharge	Amount

Subtotal: \$0.00

Supervisor Signature X \_\_\_\_\_

Approval Signature X \_\_\_\_\_

**Total: \$7,636.24**





# INVOICE

**Invoice No:** F00175257  
**Invoice Date:** December 06, 2019  
**Payment Terms:** Net 30  
**Contract No:**  
**Reference:** 104-190032: Dicker Road HDD

**Location:** Dicker Road HDD  
**PO:**  
**AFE:**  
**WO:**  
**Other:** 17MH033

**To:** Lonestar Pipeline Company, LLC  
 c/o AP  
 c/o Kindle Energy LLC  
 500 Alexander Park Drive, Suite 300  
 Princeton, New Jersey 08540

**Remit To:** Strike, LLC  
 PO Box 844338  
 Dallas, TX 75284-4338  
  
**Or**  
**Wire:** Bank of America  
 ABA #026009593  
**ACH:** ABA #111000012  
 Strike, LLC  
 Account #4451217749

**Description:** 2 WELDERS TESTED FOR LONESTAR PIPELINE AND PASSES. HAULED PIPE FROM MISSION YARD TO DICKER RD. HAULED TRACK-HOE FROM DITCH TO DICKER RD. FABRICATED THE EAST SIDE TIE IN WITH TEST HEAD. X-RAYED AND COATED. MADE SECOND BELL HOLE ON THE WEST SIDE. FABRICATED AND ADDED TEST HEAD. LOADED WATER FOR HYDRO TEST. 3RD PARTY HYDRO TEST 8 HR. TOPPED OFF 8" LINE ON EAST SIDE OF BORE FOR HYDRO TEAM. DOUBLE CHECKED ALL PLUGS ON VALVES ASSISTED HYDRO TEAM WRAP UP THE TEST. DE-WATERED THE 8" PL. PUSHED PIG. TIED IN TO PIPE ON EAST SIDE. FINISHED THE WEST TIE IN. BLASTED IN COATED BOTH ENDS. PULLED OUT EXISTING PIPE FROM CASING. CUT EXISTING PIPE INTO 30 FT SECTIONS WITH TORCH. OPERATOR BACK FILLED ON COMPACTED BOTH BELL HOLES. POURED FLOWABLE FILL ON BOTH TIE IN POINTS. LOADED OLD CUT SECTIONS OF 30 FT JOINTS TO GOOSENECK. BACK FILLED AND COMPACTED WITH SOIL AND CALICHE. PICKED UP ALL TRAFFIC SIGNS. PO RENTAL VACTRON.

Ticket No.	Ticket Date	Labor	Equipment	Materials	Per Diem	Total
2901725	10/28/2019	\$2,402.60	\$720.00	\$2,560.60	\$580.00	\$6,263.20
893484	11/18/2019	\$0.00	\$0.00	\$1,899.80	\$0.00	\$1,899.80
893931	11/23/2019	\$9,115.83	\$3,978.00	\$0.00	\$0.00	\$13,093.83
893487	11/24/2019	\$0.00	\$0.00	\$5,433.90	\$0.00	\$5,433.90
893932	11/24/2019	\$1,130.40	\$446.00	\$0.00	\$0.00	\$1,576.40
893934	11/25/2019	\$5,259.64	\$3,134.00	\$0.00	\$0.00	\$8,393.64
893935	11/26/2019	\$5,259.64	\$3,440.00	\$0.00	\$0.00	\$8,699.64
893936	11/27/2019	\$5,974.62	\$3,756.00	\$0.00	\$0.00	\$9,730.62
5166456	12/2/2019	\$0.00	\$0.00	-\$210.86	\$0.00	-\$210.86
		\$29,142.73	\$15,474.00	\$9,683.44	\$580.00	\$54,880.17

<See Next Page>



# INVOICE

<i>Non-taxable Subtotal including any Discounts</i>	\$54,880.17
<i>Taxable Subtotal including any Discounts</i>	\$0.00
<i>Sales Tax :: State Of Texas- 440000000 :: 6.25%</i>	\$0.00
<b>Sales Tax Subtotal</b>	<b>\$0.00</b>

**Total Invoice Due:**

**\$54,880.17**

TxDOT  
Reimbursable

COPY



## INVOICE SUMMARY

### LABOR

Classification Description	Standard Hours	Hourly Rate	Overtime Hours	Overtime Rate	Standard Total	Overtime Total	Surcharge	Labor Total
Craft Helper - B	32.00	\$35.58	19.00	\$49.45	\$1,138.56	\$939.55	\$0.00	\$2,078.11
Craftsman - A	24.00	\$52.99	17.00	\$75.33	\$1,271.76	\$1,280.61	\$0.00	\$2,552.37
Equipment Operator - A	24.00	\$57.74	17.00	\$82.39	\$1,385.76	\$1,400.63	\$0.00	\$2,786.39
Foreman - Labor	24.00	\$49.82	6.00	\$70.63	\$1,195.68	\$423.78	\$0.00	\$1,619.46
Quality Associate	8.00	\$54.57	10.00	\$77.69	\$436.56	\$776.90	\$0.00	\$1,213.46
Skilled Laborer	112.00	\$34.00	107.00	\$47.10	\$3,808.00	\$5,039.70	\$0.00	\$8,847.70
Superintendent B	24.00	\$78.31	17.00	\$112.98	\$1,879.44	\$1,920.66	\$0.00	\$3,800.10
Truck Driver - A (Equipment Operator w/ CDL)	8.00	\$54.57	2.00	\$77.69	\$436.56	\$155.38	\$0.00	\$591.94
Welder - Certified (w/o Rig)	32.00	\$75.15	30.00	\$108.28	\$2,404.80	\$3,248.40	\$0.00	\$5,653.20
<b>Labor Total</b>	<b>288.00</b>		<b>225.00</b>		<b>\$13,957.12</b>	<b>\$15,185.61</b>	<b>\$0.00</b>	<b>\$29,142.73</b>

### EQUIPMENT

Equipment Name	Quantity	Rate	Amount	Surcharge	Equipment Total
Air Compressors - 185 CFM	2.00	\$254.00	\$508.00	\$0.00	\$508.00
Excavator - 20 to 24 Metric Ton - (Machine with Standard Bucket)	41.00	\$99.00	\$4,059.00	\$0.00	\$4,059.00
Rubber Tire Backhoe (Machine with Standard Bucket)	41.00	\$43.00	\$1,763.00	\$0.00	\$1,763.00
Skid Steer Mini Loader	20.00	\$56.00	\$1,120.00	\$0.00	\$1,120.00
Trailer - Bumper Pull Utility	1.00	\$86.00	\$86.00	\$0.00	\$86.00
Trailer - Gooseneck Tandem Axle	1.00	\$116.00	\$116.00	\$0.00	\$116.00
Truck - 1 Ton (Double Rear Wheel)	10.00	\$36.00	\$360.00	\$0.00	\$360.00
Truck - 1 Ton (Weld Rig)	62.00	\$36.00	\$2,232.00	\$0.00	\$2,232.00
Truck - 1/2 to 3/4 ton	135.00	\$30.00	\$4,050.00	\$0.00	\$4,050.00
Truck - Contract Operator/Straw Pickup	59.00	\$20.00	\$1,180.00	\$0.00	\$1,180.00
<b>Equipment Total</b>			<b>\$15,474.00</b>	<b>\$0.00</b>	<b>\$15,474.00</b>

### PER DIEM

Quantity	Rate	Amount	Surcharge	Per Diem Total
4.00	\$145.00	\$580.00	\$0.00	\$580.00
<b>Per Diem Total</b>		<b>\$580.00</b>	<b>\$0.00</b>	<b>\$580.00</b>

### MATERIAL

Material Name	Mark up	Cost	SalesTax	Amount	Surcharge	Material Total
VACTRON RENTAL DELIVERY/PICKUP	-\$30.06	-\$167.02	-\$13.78	-\$180.80	\$0.00	-\$210.86
HYDRO TEST	\$828.90	\$4,605.00	\$0.00	\$4,605.00	\$0.00	\$5,433.90
HAULING EQUIPMENT AND PIPE	\$144.90	\$805.00	\$0.00	\$805.00	\$0.00	\$949.90
HAULING EQUIPMENT AND PIPE	\$144.90	\$805.00	\$0.00	\$805.00	\$0.00	\$949.90
HAULING EQUIPMENT	\$124.20	\$690.00	\$0.00	\$690.00	\$0.00	\$814.20
WELDING TEST	\$266.40	\$1,480.00	\$0.00	\$1,480.00	\$0.00	\$1,746.40
<b>Material Total</b>	<b>\$1,479.24</b>		<b>-\$13.78</b>	<b>\$8,204.20</b>	<b>\$0.00</b>	<b>\$9,683.44</b>

Non-Taxable Subtotal	\$54,880.17
Taxable Subtotal	\$0.00
Sales Tax Subtotal	\$0.00
<b>Total Invoice Due</b>	<b>\$54,880.17</b>



**Daily Labor & Equipment Time Ticket**

Date: 10/28/2019

Ticket No: 2901725

Client: Lonestar Pipeline Company, LLC      Location: MAVERICK TESTING LAB      Job No: 104-190032.095

Other: 17MH033

2 WELDERS TESTED FOR LONESTAR PIPELINE AND PASSES.

Combo Rate Description	Combo ID	ST Hours	OT Hours	ST Rate	OT Rate	Surcharge	Amount

**Subtotal: \$0.00**

Emp No.	Employee Name	Per Diem	Classification	ST Hours	OT Hours	ST Rate	OT Rate	Surcharge	Amount
122196	Cuate, Arnulfo	Yes	Welder - Certified (w/o Rig)	8.00	2.00	\$75.15	\$108.28	\$0.00	\$817.76
136337	Perez, Ivan	Yes	Welder - Certified (w/o Rig)	8.00	2.00	\$75.15	\$108.28	\$0.00	\$817.76
121491	Arevalo, Heriberto	Yes	Craft Helper - B	8.00	2.00	\$35.58	\$49.45	\$0.00	\$383.54
127083	Perez, Abelardo	Yes	Craft Helper - B	8.00	2.00	\$35.58	\$49.45	\$0.00	\$383.54

**Subtotal: \$2,402.60**

Number	Per Diem	Rate	Surcharge	Amount
4	Per Diem	\$145.00	\$0.00	\$580.00

**Subtotal: \$580.00**

Equipment Name	Fleet Asset ID	Hours/Day	Rate	PO No	Vendor Name	Surcharge	Amount
Truck - 1 Ton (Weld Rig)		10.00	\$36.00			\$0.00	\$360.00
Truck - 1 Ton (Weld Rig)		10.00	\$36.00			\$0.00	\$360.00

**Subtotal: \$720.00**

Material Name	Vendor Name	PO No	Cost	Mark Up	Sales Tax	Surcharge	Amount
WELDING TEST	ALS MAVERICK TESTING	104641522	\$1,490.00	\$266.40	\$0.00	\$0.00	\$1,746.40
HAULING EQUIPMENT	TEXAN DUMP TRUCKS	104641559	\$690.00	\$124.20	\$0.00	\$0.00	\$814.20

**Subtotal: \$2,560.60**

Supervisor Signature      X \_\_\_\_\_  
 Approval Signature      X \_\_\_\_\_

**Total: \$6,263.20**

Last Modified: 11/26/2019 3:52:18 PM

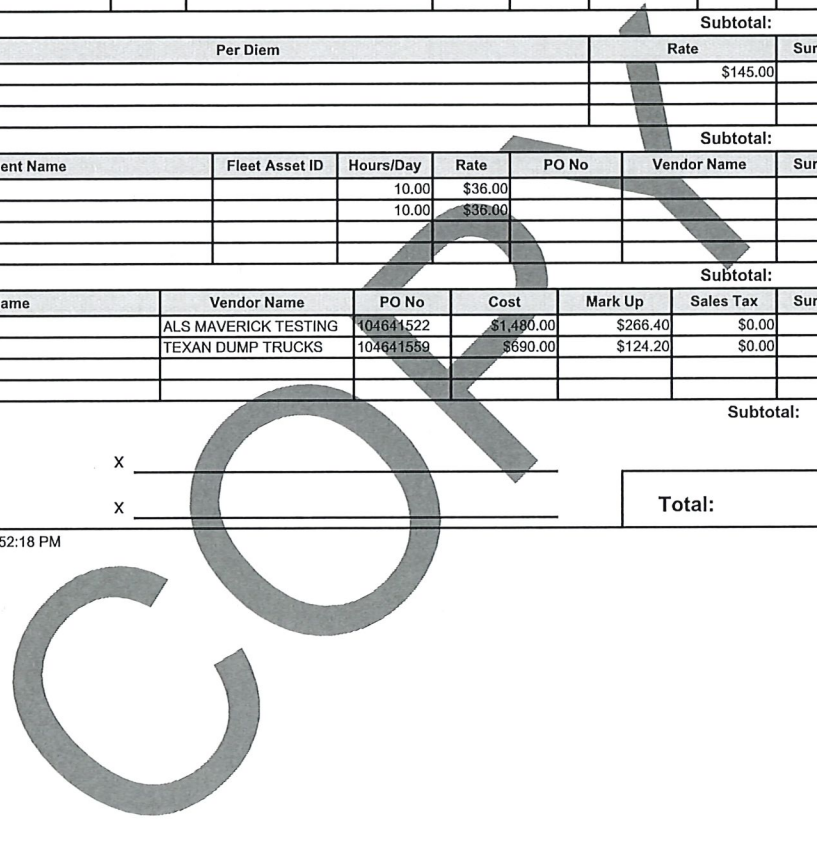

Date: 10 / 28 / 2019

Job No: 104-190032-095

Client Name: LONG STAR

Project Name: DICKER RD HDD

Ticket No: 2901725

City: CORPUS CHRISTI

Location/Site Name: MAVERICK TESTING LAB

AFE/PID: 17MH033

County: NUECES

State: TEXAS



Description of Work  
2 WELDERS TESTED FOR LONESTAR PIPELINE AND PASSED.

Emp. No.	Employee Name	Classification	ST Hrs	OT Hrs	P/Diem	T/Rent	Amount
<u>122196</u>	<u>ARNUEFO CUATE</u>	<u>WEIDER</u>	<u>8</u>	<u>2</u>	<u>X</u>	<u>X</u>	
<u>136337</u>	<u>IVAN PEREZ</u>	<u>WEIDER</u>	<u>8</u>	<u>2</u>	<u>X</u>	<u>X</u>	
<u>121491</u>	<u>HERIBERTO AREVALO</u>	<u>CRAFT HELPER B</u>	<u>8</u>	<u>2</u>	<u>X</u>		
<u>127083</u>	<u>ABELARDO PEREZ</u>	<u>CRAFT HELPER B</u>	<u>8</u>	<u>2</u>	<u>X</u>		

Subtotal

Equipment Description	Unit No.	Hours/Days	Amount
<u>welding rig</u>	<u>A. CUATE</u>	<u>10</u>	
<u>welding rig</u>	<u>J. PEREZ</u>	<u>10</u>	

Subtotal

Material/Subs/Rental Desc.	Vendor	Inv. No.	PO#	Amount
<u>WELDER TEST</u>	<u>ALS</u>		<u>10464 1522</u>	
<u>HAULING TRACK HOE</u>	<u>TDT</u>		<u>10464 1559</u>	

Subtotal

Supervisor Signature X [Signature]

Approval Signature X [Signature]

Total	
-------	--



**ALS Maverick Testing Labs, Inc**  
 320 Deerwood Glen Dr.  
 Deer Park, TX 77536  
**Phone: 281-888-8210**  
 Email:maverick.accounting@alsglobal.com

**INVOICE**

Date	Invoice No.
11/12/2019	IN016414

**BILL TO:**  
 Strike  
 1800 Hughes Landing Blvd. - Ste 5000  
 Woodlands, TX 77380

**SHIP TO:**  
 Strike  
 1800 Hughes Landing Blvd. - Ste 5000  
 Woodlands, TX 77380

CUSTOMER P.O. NO.	SITE ID	TEST DATE
104641522	CORPUS	10/28/2019

ITEM	RESULTS	DESCRIPTION	SS#	QTY	RATE	AMT
RWQ-20 -0124	Pass	Name: Arnulfo Cuate Jr. Lab# CC-RWQ19-389 API 1104 Butt (20th Edition)	5936 Date: 10/28/2019	1.00	400.00	400.00
RWQ-20 -0125	Pass	Name: Arnulfo Cuate Jr. Lab# CC-RWQ19-389 API 1104 Branch (20th Edition)	5936 Date: 10/28/2019	1.00	340.00	340.00
RWQ-20 -0124	Pass	Name: Ivan Perez Lab# CC-RWQ19-390 API 1104 Butt (20th Edition)	6969 Date: 10/28/2019	1.00	400.00	400.00
RWQ-20 -0125	Pass	Name: Ivan Perez Lab# CC-RWQ19-390 API 1104 Branch (20th Edition)	6969 Date: 10/28/2019	1.00	340.00	340.00

CHECK REMITTANCE: **ALS Maverick Testing Laboratories, Inc.**  
 P.O. Box 733319  
 Dallas, TX 75373-3319

ACH/WIRE REMITTANCE: **ALS Maverick Testing Laboratories, Inc.**  
 JP Morgan Chase, N.A., Dallas, TX  
 ABA Routing 111000614 / Acct 816015650 / Swift Code CHASUS33

Sales Total 1,480.00  
 Freight Total 0.00  
 Tax Total 0.00

Where Personal Service and Quality Meet

**TOTAL** \$1,480.00



**ALS MAVERICK TESTING LABORATORIES, INC.**

7325 IH-37 Corpus Christi, Texas 78409  
Ph. 361-299-6820 Fx. 361-299-6825  
Welding Procedures – Welder Performance – Coupon Production  
Where Personal Service & Quality Meet



**Testing Instruction Form**

Company Name: LONESTAR PIPELINE / STRIKE USA

Date: 10/28/2019

Company Contact: Juan Salinas / Ricardo Garcia

PO#: [Redacted]

Welders Name: Arnulfo Cuate

SS#: 5936

1.) Type of Material:	Pipe	Pipe	Pipe or Plate
2.) Grade of Material:	X52		
	Butt and Branch		
3.) Size of Material:	12.75" x .250"		
4.) Filler Material:	E6010/8010-P1		
5.) Position of Test:			
6.) WPS #:	WPS-API-2001		

Pass Fail L/O       Pass Fail L/O       Pass Fail L/O

ASME

AWS

API

Witnessed By: [Signature]      Witnessed by: \_\_\_\_\_

Date: 10/28/19

	Name	Email Address
Send Results to:	Juan Salinas	<a href="mailto:juan.salinas@strikeusa.com">juan.salinas@strikeusa.com</a>
	Guadalupe Salinas	<a href="mailto:guadalupe.salinas@strikeusa.com">guadalupe.salinas@strikeusa.com</a>
	Ricardo Garcia	<a href="mailto:ricardo.garcia2@strikeusa.com">ricardo.garcia2@strikeusa.com</a>
Send Certs to:	Juan Salinas	<a href="mailto:juan.salinas@strikeusa.com">juan.salinas@strikeusa.com</a>
	Guadalupe Salinas	<a href="mailto:guadalupe.salinas@strikeusa.com">guadalupe.salinas@strikeusa.com</a>
	Ricardo Garcia	<a href="mailto:ricardo.garcia2@strikeusa.com">ricardo.garcia2@strikeusa.com</a>

Special Instructions: [Redacted]

**Thomas Ward**

---

**From:** Juan Salinas <Juan.Salinas@strikeusa.com>  
**Sent:** Thursday, October 24, 2019 9:12 AM  
**To:** Thomas Chalkley; MaverickCC.Testing; Daniel Earp  
**Cc:** Guadalupe Salinas; Ricardo Garcia  
**Subject:** RE: [EXTERNAL] - Test for Lonestar PL  
**Attachments:** Arnulfo Cuate ALS Maverick ASME Test Form - LONESTAR-Strike USA.xls; Ivan Perez ALS Maverick ASME Test Form - LONESTAR-Strike USA.xls; WPS-API-2001.pdf

Thomas,

See attached Test Forms for 2 welders we would like to set up to test Monday 10-28-19 for Lonestar PL.

Please send me a total \$ for both and we will issue a PO accordingly.

Thanks,

 **Juan Salinas**  
Project Manager  
10465 N. Conway Ave., Mission, TX 78573  
Direct: 713.389.2482 | Mobile: 832.794.8048  
[Juan.Salinas@strikeusa.com](mailto:Juan.Salinas@strikeusa.com) | [www.strikeusa.com](http://www.strikeusa.com)

DISCLAIMER: This e-mail and any files transmitted with it are confidential and intended solely for the individual or entity named above. If you have received this e-mail by mistake, please notify the sender immediately by e-mail. If you are not the named addressee you should not disseminate, distribute or copy this e-mail. Please notify the sender immediately by e-mail if you have received this e-mail by mistake and delete this e-mail from your system. If you are not the named addressee you should not disseminate, distribute or copy this e-mail. Please notify the sender immediately by e-mail if you have received this e-mail by mistake and delete this e-mail from your system. If you are not the named addressee you should not disseminate, distribute or copy this e-mail. Please notify the sender immediately by e-mail if you have received this e-mail by mistake and delete this e-mail from your system. If you are not the named addressee you should not disseminate, distribute or copy this e-mail. Please notify the sender immediately by e-mail if you have received this e-mail by mistake and delete this e-mail from your system.

Please consider the environment before printing this e-mail

**From:** Thomas Chalkley <thomas.chalkley@alsglobal.com>  
**Sent:** Tuesday, October 22, 2019 1:55 PM  
**To:** Juan Salinas <Juan.Salinas@strikeusa.com>; MaverickCC.Testing <MaverickCC.Testing@alsglobal.com>; Daniel Earp <Daniel.Earp@strikeusa.com>  
**Cc:** Guadalupe Salinas <Guadalupe.Salinas@strikeusa.com>; Ricardo Garcia <Ricardo.Garcia2@strikeusa.com>  
**Subject:** Re: [EXTERNAL] - Test for Lonestar PL

Mr. Salinas,  
If we test your welders on a full API butt and branch multi qual per the Strike 2001 referenced WPS they will be qualified to weld to both 1001 & 2001 WPS's. Both WPSs utilize the same groups I & Group II consumables so testing to each WPS individually is not necessary and would be redundant.

Please let me know if this answers questions for your client or if you need additional clarification.

If we are good to go send over test instructions and the WPS again and we will get them set up for Friday.

Thank you Sir.

Thomas E. Chalkley

Operations Manager / Sr CWI

ALS-Maverick Testing Laboratories

Corpus Christi, Tx  
1-361-945-0307

Sent from my iPhone

On Oct 22, 2019, at 10:35 AM, Juan Salinas <[Juan.Salinas@strikeusa.com](mailto:Juan.Salinas@strikeusa.com)> wrote:

**CAUTION:** This email originated from outside of ALS. Do not click links or open attachments unless you recognize the sender and are sure content is relevant to you.

Thomas,

Can we multi-qualify welders with WPS-API-2001 procedure and it will cover them to weld on X-42 to X-42 pipe?  
Planning on testing welders Friday this week.

Please advise.

Thanks,



10465 N. Conway Ave., Mission, TX 78573  
Direct: 713.389.2482 | Mobile: 832.794.8048  
[Juan.Salinas@strikeusa.com](mailto:Juan.Salinas@strikeusa.com) | [www.strikeusa.com](http://www.strikeusa.com)

© 2014-2019. This email and any files transmitted with it are confidential and intended only for the individual(s) named. If you are not the named individual(s) do not disseminate, distribute or copy this e-mail. Please notify the sender immediately by e-mail if you have received this e-mail by mistake. If you do not believe you should have received this e-mail, do not reply, do not delete it, do not forward it, do not print it, do not use it, do not rely on it, do not act on it, do not disseminate it, do not use the information it contains, do not copy it, do not make any hard copies, and notify the sender immediately by e-mail if you have received this e-mail by mistake. Do not use any information contained in this e-mail for any purpose other than the purpose for which it was transmitted. Please consider the environment before printing this e-mail.

<WPS-API-2001.pdf>

<WPS-API-1001.pdf>

1. Visitor hereby acknowledges, agrees and understands that:
  - a. activities at the Facilities are dangerous and involve risks of serious injury, death and/or property damage; and
  - b. Visitor has the sole responsibility to evaluate the risks inherent in accessing the Facilities and that Visitor has fully considered those risks, including without limitation, dangers posed by willful or negligent acts or omissions of Visitor or others; and
  - c. Visitor assumes full responsibility and liability for all personal injury, death or damage to property which occurs as a result of Visitor's entry onto or presence at the Facilities.
2. To the fullest extent permitted by law, Visitor hereby **RELEASES, WAIVES, DISCHARGES, and COVENANTS NOT TO SUE** Maverick, its affiliates, its subcontracts and any other person engaged by Maverick to perform work at the Facilities (**Indemnitees**) from or for any and all damages, losses, penalties, liabilities, costs (including but not limited to attorneys' fees), and claims arising out of or resulting from Visitor's entry onto or presence at the Facilities.
3. To the fullest extent permitted by law, Visitor hereby acknowledges and agrees that Visitor shall **INDEMNIFY, DEFEND AND HOLD HARMLESS** the Indemnitees from and against any and all claims, liabilities, losses or expenses, including legal and attorneys' fees and court costs, arising out of or in connection with Visitor's presence at the Facilities.
4. Visitor hereby acknowledges, agrees and understands that its release and indemnity obligations under this Waiver of Liability and Release shall apply regardless of fault, whether caused in whole or in part by the negligence, gross negligence, willful misconduct, or strict liability (or otherwise) of the Indemnitees, to the fullest extent permitted by law.
5. Visitor expressly understands and agrees that if any provision of this Waiver of Liability and Release is found by a court of competent jurisdiction to be unenforceable against the Visitor, ~~such provision shall not be rendered void but~~ shall apply to the maximum extent as such court may judicially determine as enforceable. Alternatively, if any court of competent jurisdiction finds that any provision contained herein is unenforceable, and such provision cannot be amended so as to make it enforceable, such finding shall not affect the enforceability of any other provision contained herein.

I have received and read the General Safety Information for Maverick Testing Laboratories Inc. and this Waiver of Liability and Release. I understand the significance of this document and hereby acknowledge and agree to all of these terms.

ARNULFO CUATE Arnulfo Cuate 10-28-19  
PRINT NAME SIGNATURE DATE



**ALS MAVERICK TESTING LABORATORIES, INC.**

7325 IH-37 Corpus Christi, Texas 78409  
Ph. 361-299-6820 Fx. 361-299-6825

Welding Procedures – Welder Performance – Coupon Production  
Where Personal Service & Quality Meet



**American Welding Society**  
Sustaining Company Member

**Testing Instruction Form**

Company Name: LONESTAR PIPELINE / STRIKE USA

Date: 10/28/2019

Company Contact: Juan Salinas / Ricardo Garcia

PO#: [Redacted]

Welders Name: Ivan Perez

SS#: 6969

1.) Type of Material:	Pipe	Pipe	Pipe or Plate
2.) Grade of Material:	X52		
3.) Size of Material:	12.75" x .250"		
4.) Filler Material:	E6010/8010P1		
5.) Position of Test:			
6.) WPS #:	WPS-API-2001		

Pass Fail L/O      Pass Fail L/O      Pass Fail L/O

ASME       AWS       API

Witnessed By: [Signature]      Witnessed by: \_\_\_\_\_

Date: 10/29

	Name	Email Address
Send Results to:	Juan Salinas	<a href="mailto:juan.salinas@strikeusa.com">juan.salinas@strikeusa.com</a>
	Guadalupe Salinas	<a href="mailto:guadalupe.salinas@strikeusa.com">guadalupe.salinas@strikeusa.com</a>
	Ricardo Garcia	<a href="mailto:ricardo.garcia2@strikeusa.com">ricardo.garcia2@strikeusa.com</a>
Send Certs to:	Juan Salinas	<a href="mailto:juan.salinas@strikeusa.com">juan.salinas@strikeusa.com</a>
	Guadalupe Salinas	<a href="mailto:guadalupe.salinas@strikeusa.com">guadalupe.salinas@strikeusa.com</a>
	Ricardo Garcia	<a href="mailto:ricardo.garcia2@strikeusa.com">ricardo.garcia2@strikeusa.com</a>

Special Instructions: [Redacted]

## Thomas Ward

---

**From:** Juan Salinas <Juan.Salinas@strikeusa.com>  
**Sent:** Thursday, October 24, 2019 9:12 AM  
**To:** Thomas Chalkley; MaverickCC.Testing; Daniel Earp  
**Cc:** Guadalupe Salinas; Ricardo Garcia  
**Subject:** RE: [EXTERNAL] - Test for Lonestar PL  
**Attachments:** Arnulfo Cuate ALS Maverick ASME Test Form - LONESTAR-Strike USA.xls; Ivan Perez ALS Maverick ASME Test Form - LONESTAR-Strike USA.xls; WPS-API-2001.pdf

Thomas,

See attached Test Forms for 2 welders we would like to set up to test Monday 10-28-19 for Lonestar PL.

Please send me a total \$ for both and we will issue a PO accordingly.

Thanks,

**Juan Salinas**  
Project Manager  
 10465 N. Conway Ave., Mission, TX 78573  
Direct: 713.389.2482 | Mobile: 832.794.8048  
[Juan.Salinas@strikeusa.com](mailto:Juan.Salinas@strikeusa.com) | [www.strikeusa.com](http://www.strikeusa.com)

DISCLAIMER: This e-mail and any files transmitted with it are confidential and intended solely for the use of the individual or entity to whom they are addressed. If you have received this e-mail by mistake or have any questions, please notify the sender immediately by e-mail. If you are not the intended recipient you should not disseminate, distribute or copy this e-mail. Please notify the sender immediately by e-mail if you have received this e-mail by mistake and delete this e-mail from your system. If you are not the intended recipient you should not disseminate, distribute or copy this e-mail. Please notify the sender immediately by e-mail if you have received this e-mail by mistake and delete this e-mail from your system. If you are not the intended recipient you should not disseminate, distribute or copy this e-mail. Please notify the sender immediately by e-mail if you have received this e-mail by mistake and delete this e-mail from your system.

Please consider the environment before printing this e-mail

**From:** Thomas Chalkley <thomas.chalkley@alsglobal.com>  
**Sent:** Tuesday, October 22, 2019 1:55 PM  
**To:** Juan Salinas <Juan.Salinas@strikeusa.com>; MaverickCC.Testing <MaverickCC.Testing@alsglobal.com>; Daniel Earp <Daniel.Earp@strikeusa.com>  
**Cc:** Guadalupe Salinas <Guadalupe.Salinas@strikeusa.com>; Ricardo Garcia <Ricardo.Garcia2@strikeusa.com>  
**Subject:** Re: [EXTERNAL] - Test for Lonestar PL

Mr. Salinas,

If we test your welders on a full API butt and branch multi qual per the Strike 2001 referenced WPS they will be qualified to weld to both 1001 & 2001 WPS's. Both WPSs utilize the same groups I & Group II consumables so testing to each WPS individually is not necessary and would be redundant.

Please let me know if this answers questions for your client or if you need additional clarification.

If we are good to go send over test instructions and the WPS again and we will get them set up for Friday.

Thank you Sir.

Thomas E. Chalkley

Operations Manager / Sr CWI

ALS-Maverick Testing Laboratories

Corpus Christi, Tx  
1-361-945-0307

Sent from my iPhone

On Oct 22, 2019, at 10:35 AM, Juan Salinas <[Juan.Salinas@strikeusa.com](mailto:Juan.Salinas@strikeusa.com)> wrote:

**CAUTION: This email originated from outside of ALS. Do not click links or open attachments unless you recognize the sender and are sure content is relevant to you.**

Thomas,

Can we multi-qualify welders with WPS-API-2001 procedure and it will cover them to weld on X-42 to X-42 pipe?  
Planning on testing welders Friday this week.

Please advise.

Thanks,



10465 N. Conway Ave., Mission, TX 78573  
Direct: 713.389.2482 | Mobile: 832.794.8048  
[Juan.Salinas@strikeusa.com](mailto:Juan.Salinas@strikeusa.com) | [www.strikeusa.com](http://www.strikeusa.com)

DISCLAIMER: This email and any files transmitted with it are confidential and intended solely for the use of the individual or entity to whom they are addressed and no other third party may rely on any information provided for in this email or any files transmitted with it. If you are not the intended recipient, do not directly or indirectly use, disclose, distribute, print, or copy any part of this message. If you receive this message in error, please immediately delete it and all copies of it from your system, destroy any hard copies, and notify the sender. **WARNING: Computer viruses can be transmitted via email; the recipient is responsible for checking for any viruses transmitted by this email.**

**Please consider the environment before printing this e-mail**

<WPS-API-2001.pdf>

<WPS-API-1001.pdf>

1. Visitor hereby acknowledges, agrees and understands that:
  - a. activities at the Facilities are dangerous and involve risks of serious injury, death and/or property damage; and
  - b. Visitor has the sole responsibility to evaluate the risks inherent in accessing the Facilities and that Visitor has fully considered those risks, including without limitation, dangers posed by willful or negligent acts or omissions of Visitor or others; and
  - c. Visitor assumes full responsibility and liability for all personal injury, death or damage to property which occurs as a result of Visitor's entry onto or presence at the Facilities.
2. To the fullest extent permitted by law, Visitor hereby **RELEASES, WAIVES, DISCHARGES, and COVENANTS NOT TO SUE** Maverick, its affiliates, its subcontracts and any other person engaged by Maverick to perform work at the Facilities (**Indemnitees**) from or for any and all damages, losses, penalties, liabilities, costs (including but not limited to attorneys' fees), and claims arising out of or resulting from Visitor's entry onto or presence at the Facilities.
3. To the fullest extent permitted by law, Visitor hereby acknowledges and agrees that Visitor shall **INDEMNIFY, DEFEND AND HOLD HARMLESS** the Indemnitees from and against any and all claims, liabilities, losses or expenses, including legal and attorneys' fees and court costs, arising out of or in connection with Visitor's presence at the Facilities.
4. Visitor hereby acknowledges, agrees and understands that its release and indemnity obligations under this Waiver of Liability and Release shall apply regardless of fault, whether caused in whole or in part by the negligence, gross negligence, willful misconduct, or strict liability (or otherwise) of the Indemnitees, to the fullest extent permitted by law.
5. Visitor expressly understands and agrees that if any provision of this Waiver of Liability and Release is found by a court of competent jurisdiction to be unenforceable against the Visitor, ~~such provision shall not be rendered void but~~ shall apply to the maximum extent as such court may judicially determine as enforceable. Alternatively, if any court of competent jurisdiction finds that any provision contained herein is unenforceable, and such provision cannot be amended so as to make it enforceable, such finding shall not affect the enforceability of any other provision contained herein.

I have received and read the General Safety Information for Maverick Testing Laboratories Inc. and this Waiver of Liability and Release. I understand the significance of this document and hereby acknowledge and agree to all of these terms.

Ivan Perez  
PRINT NAME

[Signature]  
SIGNATURE

10-28-19  
DATE



TEXAN DUMP TRUCKS & CONSTRUCTION  
P.O. BOX 869  
Edinburg, TX 78540  
texandumptrucks@yahoo.com

# Invoice

**BILL TO**  
STRIKE, LLC  
1800 Hughes Landing Blvd., Suite  
500  
The Woodlands, TX. 77380

**SHIP TO**  
Dicker Rd  
Hidalgo, TX

INVOICE #	DATE	TOTAL DUE	DUE DATE	TERMS	ENCLOSED
17542	10/29/2019	\$690.00	11/28/2019	Net 30	

**SHIP DATE**  
10/28/2019

**P.O. NO**  
104641559

DESCRIPTION	QTY	RATE	AMOUNT
Tractor Trailer Lowboy -Transport excavator from Mission, TX to Hidalgo, TX, Lonestar Project, Dicker Rd.	6	115.00	690.00

Thank you for your business.

**BALANCE DUE**

**\$690.00**

COPY



Daily Labor & Equipment Time Ticket

Date: 11/18/2019

Ticket No: 893484

Client Lonestar Pipeline Company, LLC Location: HIDALGO Job No: 104-190032.095

Other: 17MH033

HAULED PIPE FROM MISSION YARD TO DICKER RD. HAULED TRACK-HOE FROM DITCH TO DICKER RD.

Combo Rate Description	Combo ID	ST Hours	OT Hours	ST Rate	OT Rate	Surcharge	Amount
<b>Subtotal:</b>							<b>\$0.00</b>

Emp No.	Employee Name	Per Diem	Classification	ST Hours	OT Hours	ST Rate	OT Rate	Surcharge	Amount
<b>Subtotal:</b>									<b>\$0.00</b>

Number	Per Diem	Rate	Surcharge	Amount
<b>Subtotal:</b>				<b>\$0.00</b>

Equipment Name	Fleet Asset ID	Hours/Day	Rate	PO No	Vendor Name	Surcharge	Amount
<b>Subtotal:</b>							<b>\$0.00</b>

Material Name	Vendor Name	PO No	Cost	Mark Up	Sales Tax	Surcharge	Amount
HAULING EQUIPMENT AND PIPE	TEXAN DUMP TRUCKS	104647344	\$805.00	\$144.90	\$0.00	\$0.00	\$949.90
HAULING EQUIPMENT AND PIPE	TEXAN DUMP TRUCKS	104647344	\$805.00	\$144.90	\$0.00	\$0.00	\$949.90
<b>Subtotal:</b>							<b>\$1,899.80</b>

Supervisor Signature X \_\_\_\_\_

Approval Signature X \_\_\_\_\_

Total: \$1,899.80

Last Modified: 11/25/2019 4:57:12 PM

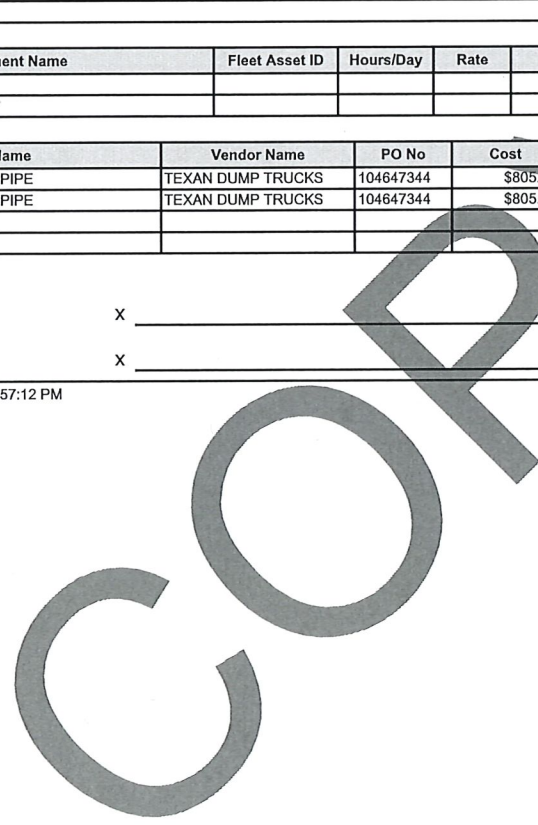





TEXAN DUMP TRUCKS & CONSTRUCTION  
P.O. BOX 869  
Edinburg, TX 78540  
texandumptrucks@yahoo.com

# Invoice

**BILL TO**

STRIKE, LLC  
1800 Hughes Landing Blvd., Suite  
500  
The Woodlands, TX. 77380

**SHIP TO**

Lonestar Project  
Hidalgo, TX

INVOICE #	DATE	TOTAL DUE	DUE DATE	TERMS	ENCLOSED
17553	11/18/2019	\$805.00	12/18/2019	Net 30	

**SHIP DATE**  
11/11/2019

**P.O. NO**  
104647344

DESCRIPTION	QTY	RATE	AMOUNT
Tractor Trailer Lowboy -Transport fabrication from Mission, TX to Hidalgo, TX 7 hours @ 115/hour	7	115.00	805.00

Thank you for your business.

**BALANCE DUE**

**\$805.00**

COPY



TEXAN DUMP TRUCKS & CONSTRUCTION  
P.O. BOX 869  
Edinburg, TX 78540  
texandumptrucks@yahoo.com

# Invoice

**BILL TO**

STRIKE, LLC  
1800 Hughes Landing Blvd., Suite  
500  
The Woodlands, TX. 77380

**SHIP TO**

Lonestar Project  
Hidalgo, TX

INVOICE #	DATE	TOTAL DUE	DUE DATE	TERMS	ENCLOSED
17554	11/18/2019	\$805.00	12/18/2019	Net 30	

**SHIP DATE**  
11/11/2019

**P.O. NO**  
104647344

DESCRIPTION	QTY	RATE	AMOUNT
Tractor Trailer Lowboy -Move excavator around site Hidalgo, TX 7 hours @ 115/hour	7	115.00	805.00

Thank you for your business.

**BALANCE DUE**

**\$805.00**

COPY



**Daily Labor & Equipment Time Ticket**

Date: 11/23/2019

Ticket No: 893931

Client Lonestar Pipeline Company, LLC Location: HIDALGO Job No: 104-190032.095

Other: 17MH033  
 FABRICATED THE EAST SIDE TIE IN WITH TEST HEAD. X-RAYED AND COATED. MADE SECOND BELL HOLE ON THE WEST SIDE. FABRICATED AND ADDED TEST HEAD. LOADED WATER FOR HYDRO TEST.

Combo Rate Description	Combo ID	ST Hours	OT Hours	ST Rate	OT Rate	Surcharge	Amount

**Subtotal: \$0.00**

Emp No.	Employee Name	Per Diem	Classification	ST Hours	OT Hours	ST Rate	OT Rate	Surcharge	Amount
108210	Rocha, Hernan	No	Superintendent B	0.00	11.00	\$78.31	\$112.98	\$0.00	\$1,242.78
132411	Rios, Jorge Luis	No	Equipment Operator - A	0.00	11.00	\$57.74	\$82.39	\$0.00	\$906.29
139597	Molina, Amado	No	Craftsman - A	0.00	11.00	\$52.99	\$75.33	\$0.00	\$828.63
122196	Cuate, Arnulfo	No	Welder - Certified (w/o Rig)	0.00	11.00	\$75.15	\$108.28	\$0.00	\$1,191.08
136337	Perez, Ivan	No	Welder - Certified (w/o Rig)	0.00	11.00	\$75.15	\$108.28	\$0.00	\$1,191.08
121491	Arevalo, Heriberto	No	Craft Helper - B	0.00	11.00	\$35.58	\$49.45	\$0.00	\$543.95
107287	Cottrell, Brandon Stewart	No	Skilled Laborer	0.00	11.00	\$34.00	\$47.10	\$0.00	\$518.10
143660	Cantu, Hector	No	Skilled Laborer	0.00	11.00	\$34.00	\$47.10	\$0.00	\$518.10
147812	Cantu, Norberto	No	Skilled Laborer	0.00	11.00	\$34.00	\$47.10	\$0.00	\$518.10
139137	Gonzalez, Miguel	No	Skilled Laborer	0.00	11.00	\$34.00	\$47.10	\$0.00	\$518.10
121847	Salinas Garcia, Saturnino	No	Skilled Laborer	0.00	11.00	\$34.00	\$47.10	\$0.00	\$518.10
124660	Garcia, Ricardo	No	Quality Associate	0.00	8.00	\$54.57	\$77.69	\$0.00	\$621.52

**Subtotal: \$9,115.83**

Number	Per Diem	Rate	Surcharge	Amount

**Subtotal: \$0.00**

Equipment Name	Fleet Asset ID	Hours/Day	Rate	PO No	Vendor Name	Surcharge	Amount
Truck - Contract Operator/Straw Pickup		11.00	\$20.00			\$0.00	\$220.00
Truck - 1 Ton (Weld Rig)		11.00	\$36.00			\$0.00	\$396.00
Truck - 1 Ton (Weld Rig)		11.00	\$36.00			\$0.00	\$396.00
Truck - Contract Operator/Straw Pickup		8.00	\$20.00			\$0.00	\$160.00
Truck - 1/2 to 3/4 ton	S19-F1790	11.00	\$30.00			\$0.00	\$330.00
Truck - 1/2 to 3/4 ton	S19-F1732	11.00	\$30.00			\$0.00	\$330.00
Truck - 1/2 to 3/4 ton	S12-F447	11.00	\$30.00			\$0.00	\$330.00
Excavator - 20 to 24 Metric Ton - (Machine with Standard	S19-EX982	11.00	\$99.00			\$0.00	\$1,089.00
Rubber Tire Backhoe (Machine with Standard Bucket)	C08-BL114	11.00	\$43.00			\$0.00	\$473.00
Air Compressors - 185 CFM	S17-AC190	1.00	\$254.00			\$0.00	\$254.00

**Subtotal: \$3,978.00**

Material Name	Vendor Name	PO No	Cost	Mark Up	Sales Tax	Surcharge	Amount

**Subtotal: \$0.00**

Supervisor Signature X \_\_\_\_\_

Approval Signature X \_\_\_\_\_

**Total: \$13,093.83**





**Daily Labor & Equipment Time Ticket**

Date: 11/24/2019

Ticket No: 893487

Client Lonestar Pipeline Company, LLC Location: HIDALGO Job No: 104-190032.095

Other: 17MH033

3RD PARTY HYDRO TEST 8 HR.

Combo Rate Description	Combo ID	ST Hours	OT Hours	ST Rate	OT Rate	Surcharge	Amount
<b>Subtotal:</b>							<b>\$0.00</b>

Emp No.	Employee Name	Per Diem	Classification	ST Hours	OT Hours	ST Rate	OT Rate	Surcharge	Amount
<b>Subtotal:</b>									<b>\$0.00</b>

Number	Per Diem	Rate	Surcharge	Amount
<b>Subtotal:</b>				<b>\$0.00</b>

Equipment Name	Fleet Asset ID	Hours/Day	Rate	PO No	Vendor Name	Surcharge	Amount
<b>Subtotal:</b>							<b>\$0.00</b>

Material Name	Vendor Name	PO No	Cost	Mark Up	Sales Tax	Surcharge	Amount
HYDRO TEST	JP SERVICES	104648975	\$4,605.00	\$828.90	\$0.00	\$0.00	\$5,433.90
<b>Subtotal:</b>							<b>\$5,433.90</b>

Supervisor Signature X \_\_\_\_\_

Approval Signature X \_\_\_\_\_

<b>Total:</b>	<b>\$5,433.90</b>
---------------	-------------------

Last Modified: 12/6/2019 11:34:50 AM

COPY





# INVOICE

**\*\*Please note our new remittance address\*\***

16619 Aldine Westfield Road  
Houston, Texas 77032  
accounts.receivable@jpservices.com  
Main: 832.299.6779

Bill To:  
Attention: Accounts Payable  
Strike Construction, LLC  
1800 Hughes Landing  
Suite 500  
The Woodlands TX 77380  
United States

Date 11/24/2019  
Due Date 1/23/2020  
Invoice # 103358  
Total \$4,605.00  
2% Net 10 Discount \$92.10

### JOB INFORMATION

Customer PO:	104648975	JPS Job #	02415
Project Start Date:	11/24/2019	Service:	Hidalgo, TX 640' 8"
Project End Date:	11/24/2019	Location:	Hidalgo, TX
Owners Rep:	Juan Salinas		

Date	Description	Price	Qty	Amount
11/23/2019	Lump Sum Hydro Testing of Pipeline	\$4,605.00	1	\$4,605.00
			<b>Subtotal</b>	\$4,605.00
			<b>Total</b>	\$4,605.00

# 2019 JP Services Call Out Rate Sheet

<b>Client:</b>	<b>Strike</b>	
<b>Asset Owner</b>	<b>Lonestar</b>	
<b>JPS Job Number</b>	<b>2415</b>	
<b>Project Name</b>	<b>Hidalgo, TX 640' of 8"</b>	
<b>Location</b>	<b>Hidalgo, TX</b>	
<b>Purchase Order #</b>	<b>No. 104648975</b>	

Testing Services		Qty	Unit Price	Total
Testing @ JPS Facility	1 Hour Test (4 hour maximum)		\$850.00	\$0.00
	4 Hour Test (8 hour maximum)		\$1,200.00	\$0.00
	8 Hour Test (12 hour maximum)		\$1,800.00	\$0.00
Testing on Location	1 Hour Test (4 hour maximum)		\$2,500.00	\$0.00
	4 Hour Test (8 hour maximum)		\$3,000.00	\$0.00
	8 Hour Test (12 hour maximum)	<b>1</b>	\$3,500.00	\$3,500.00
Test Ops / Dual Test	1 Hour Test (6 hour maximum)		\$3,450.00	\$0.00
	4 Hour Test (10 hour maximum)		\$3,750.00	\$0.00
	8 Hour Test (14 hour maximum)		\$4,050.00	\$0.00
Additional Work Rate	The Additional Work rate will be charged in the event that JPS is unable to complete the project within the provided timelines, due to circumstances that are outside of JPS's control.		\$200.00	\$0.00

- All packages include: test crew, test trailer + instruments, 5 gpm test pump, 3 jumper hoses, 200 gallons water, and service vehicle
- Client to fill test section and install isolation material prior to JPS arrival
- Client is to complete bolt up of isolation material and provide a NPT connection on all yard tests

Additional Services		Qty	Unit Price	Total
Fill and leak check	8 hour maximum - includes: crew, 6x3 pump or smaller, test equipment, vehicle		\$3,200.00	\$0.00
Leak check only	4 hour maximum - includes: crew, test equipment, vehicle		\$2,500.00	\$0.00
2 man day rate	10 hour maximum - includes 2 man crew and vehicle		\$2,400.00	\$0.00
3 man day rate	10 hour maximum - includes 3 man crew and 2 vehicles		\$3,600.00	\$0.00
4 man day rate	10 hour maximum - includes 4 man crew and 2 vehicles		\$4,800.00	\$0.00

# 2019 JP Services Call Out Rate Sheet

Adders	QTY	Days	Rate	Total
Crew Travel Rate			\$200.00	\$0.00
Mileage - 120 miles to 550 miles	370	1	\$1.50	\$555.00
Mileage - over 550 miles			quote	quote
Certified Engineer Stamped Test Package			\$650.00	\$0.00
Water Buffalo w/ Pump			\$750.00	\$0.00
Large Test Pump			\$1,500.00	\$0.00
Pressure Relief Valve			\$125.00	\$0.00
Hotel and Per Diem	1	2	\$275.00	\$550.00
Extra Pressure/Temp Recorders			\$75.00	\$0.00
Jumper Hoses			\$50.00	\$0.00
			Adder Subtotal	\$1,105.00
			Estimated Project Total	\$4,605.00

## Standard Clarifications

- Standby days billed 80% hydro test day cost
- Up to 3 jumper hoses included in all test packages if requested. Qty exceeding will be charged per hose requested
- All employees will have Basic Plus, PEC Safeland, and NCCER/Veriforce Oqs. Site specific and additional training beyond these course will be charged at cost + 15% and \$65 per for classes.
- Any mobilization exceeding 120 miles round trip will be billed at the "Additional Work" hourly rate, + mileage, +hotels and per diem, as applicable
- Pricing is based on test pressures between 0 - 3,500 psi. Additional charges may be assessed for pressures exceeding 3,500.

## Data Sheet

Owner		strike construction		AFE/Auth		BTS Job	
Contractor				Project			
Owner's Rep./ Insp. Service				Name			
Test Pressure		Max	1800 psi	1700	psi	Test	1 of 1
Test Medium		water		Source			
Filled By		jp		Rate of Fill (avg)	gpm		
Fill Meter		Begin	0.0		End		
+/-	ft	"OD	"wt	gr	Pressure Pump	2000	
+/-	ft	"OD	"wt	gr	Deadweights	Mfg. Refinery	s/n
+/-	ft	"OD	"wt	gr	Pressure Recorder	Mfg. Tech Cal	s/n
+/-	ft	"OD	"wt	gr	Ambient Temp	Mfg. Tech Cal	s/n
+/-	ft	"OD	"wt	gr	Exposed Pipe Temp	Mfg. Tech Cal	s/n
+/-	ft	"OD	"wt	gr		Mfg.	s/n
+/-	ft	"OD	"wt	gr		Mfg.	s/n
From Station		To Station				Mfg.	s/n
From GPS N		To GPS N				Mfg.	s/n
W		W				Mfg.	s/n

### Hydrostatic Test Field Data

Time	Date	Pipeline Pressure	Ambient Temperature	Exposed Pipe Temperature	Remarks / Weather
9:00am	11/24/19		68	68	start pressuring up to 500
9:30am	11/24/19	500			let hold @500 for 5 min
9:35am	11/24/19				start pumping to 1000
9:40am	11/24/19	1000			stop pumping 1000 let hold for 5 min
9:45am	11/24/19				start pressurin up to 1500
9:52am	11/24/19	1500			pressure at 1500 let hold
9:57am	11/24/19				start pressurin up to test pressure 1750
10:00am	11/24/19	1754			let hole at 1754 for 15min
10:15am	11/24/19	1754	70	80	test start
10:30am	11/24/19	1755	71	81	
10:45am	11/24/19	1757	71	82	
11:00am	11/24/19	1760	73	80	
11:15 AM	11/24/19	1763	74	82	
11:30 AM	11/24/19	1766	75	82	
11:45 AM	11/24/19	1769	76	82	
12:00 PM	11/24/19	1773	77	82	
12:15p	11/24/19	1776	79	84	
12:30 PM	11/24/19	1780	80	85	
12:45 PM	11/24/2019	1782	82	86	
1:00 PM	11/24/19	1784	83	87	
1:15 PM	11/24/19	1787	83	87	
1:30 PM	11/24/19	1780	84	88	
1:54pm	11/24/19	1755	84	90	bled down from 1780 to 1755 due to temp rising
2:00pm	11/24/19	1756	84	88	
2:15pm	11/24/19	1758	84	86	
2:30pm	11/24/19	1759	85	85	

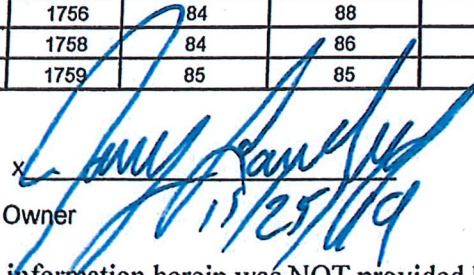
x  11/25/19  
Owner

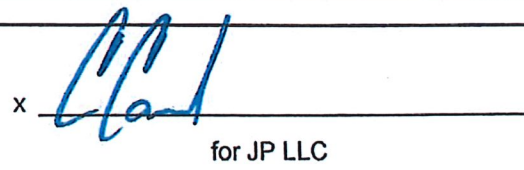
x   
for JP LLC

**DISCLAIMER:** The information herein was NOT provided by JP Services, may not be valid for any use not referred to in this Data Sheet, and may not be valid for the use of the product in combination with other materials. Except as required by law, customer acknowledges and agrees that JP Services is not liable for any loss, damage, or injury resulting from the use of this Data Sheet. NO EXPRESS OR IMPLIED WARRANTY IS MADE OF THE MERCHANTABILITY, SUITABILITY, FITNESS FOR A PARTICULAR PURPOSE OR OTHERWISE OF ANY PRODUCT OR SERVICE.



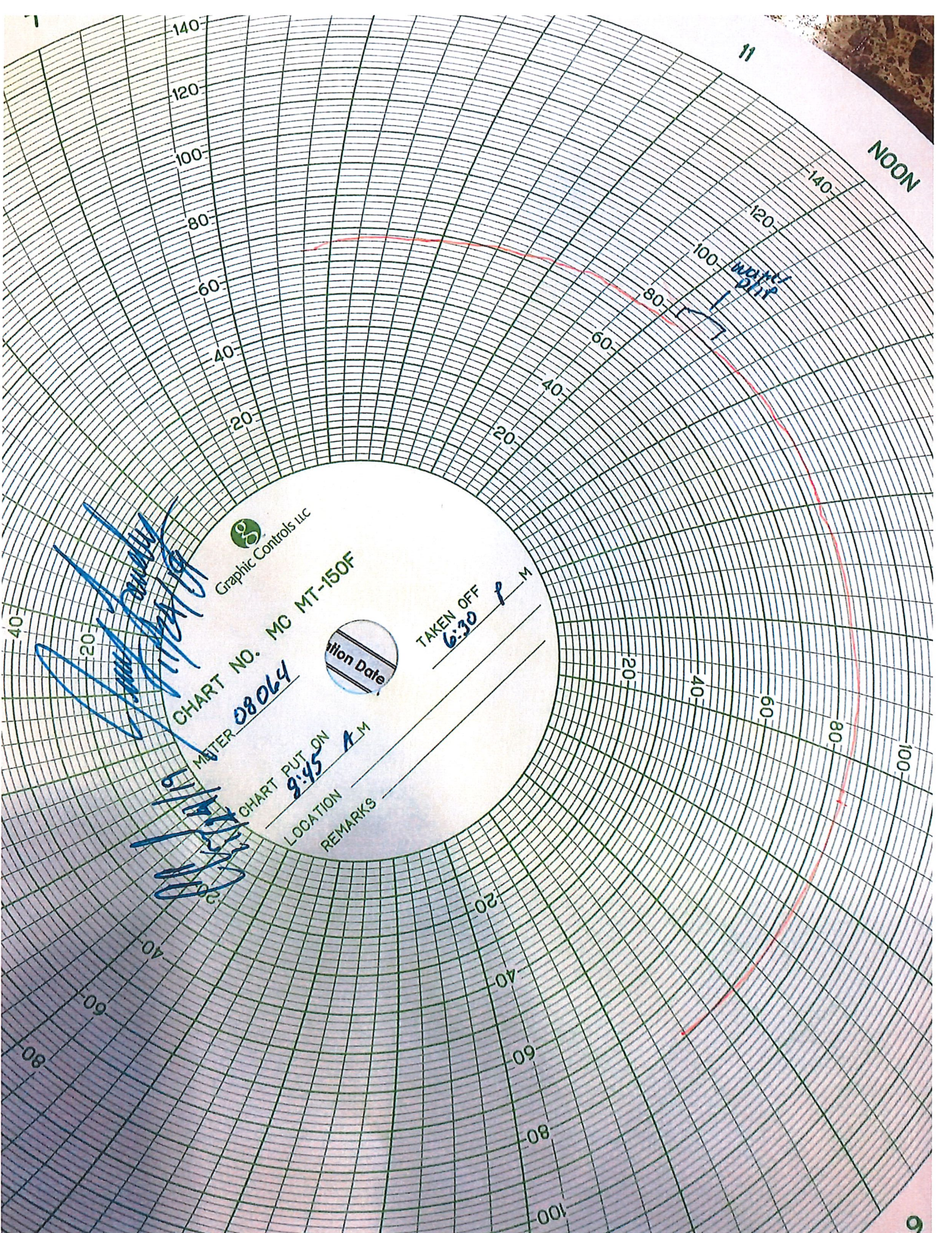

11

NOON

Graphic Controls LLC

CHART NO. MC MT-150F

METER 08064

CHART PUT ON 8:45 A.M.

Expiration Date

TAKEN OFF 6:30 P.M.

LOCATION  
REMARKS

*[Handwritten signatures and notes in blue ink]*

*[Handwritten notes in blue ink]*

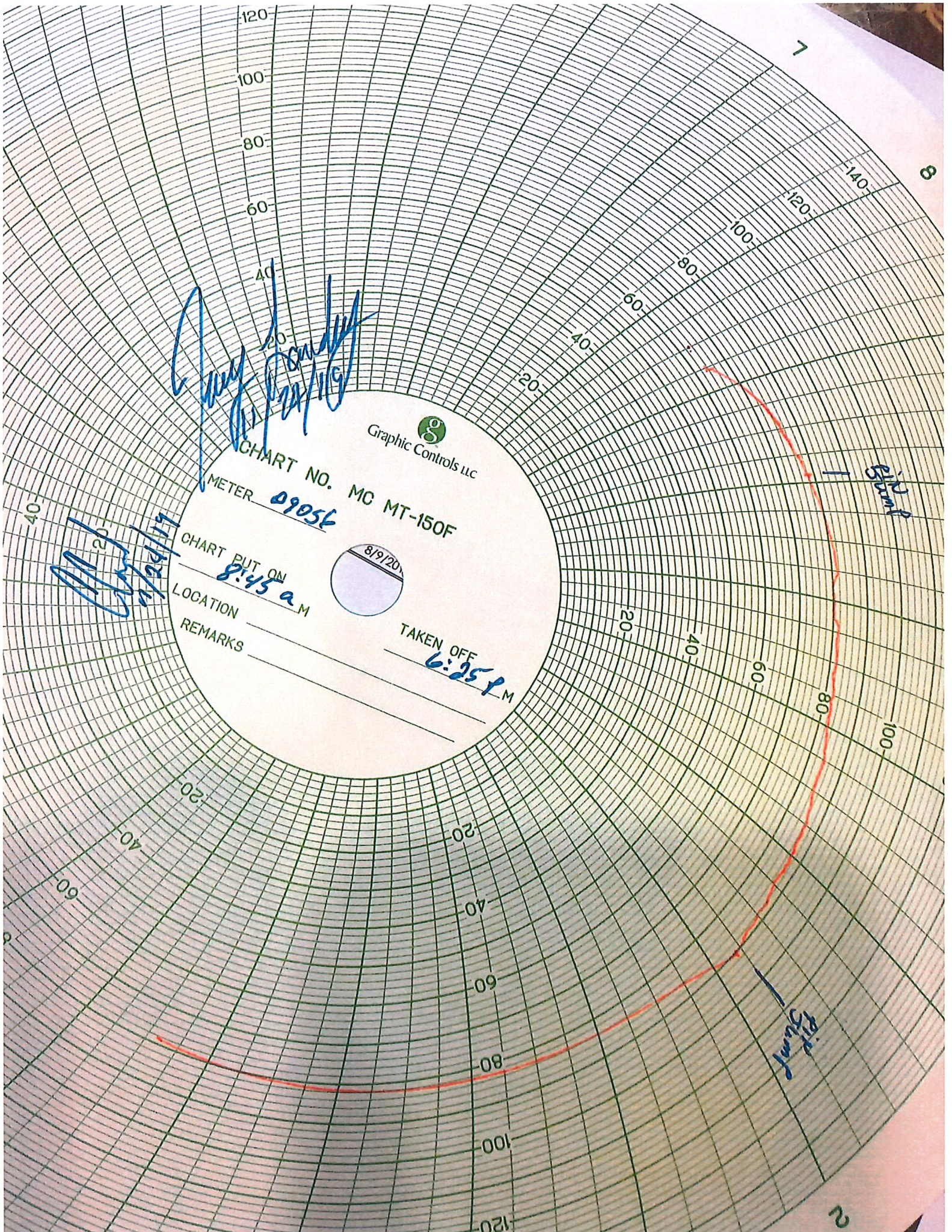

Graphic Controls LLC

CHART NO. MC MT-150F  
METER 09056

CHART PUT ON 8:45 a.m.  
LOCATION

REMARKS



TAKEN OFF 6:25 p.m.

*[Handwritten signature]*  
8/11/20

*[Handwritten signature]*  
8/11/20

*[Handwritten label]*

*[Handwritten label]*

7

8

2



Daily Labor & Equipment Time Ticket

Date: 11/24/2019

Ticket No: 893932

Client Lonestar Pipeline Company, LLC Location: HIDALGO Job No: 104-190032.095

Other: 17MH033

TOPPED OFF 8" LINE ON EAST SIDE OF BORE FOR HYDRO TEAM. DOUBLE CHECKED ALL PLUGS ON VALVES ASSISTED HYDRO TEAM WRAP UP THE TEST.

Combo Rate Description	Combo ID	ST Hours	OT Hours	ST Rate	OT Rate	Surcharge	Amount

Subtotal: \$0.00

Emp No.	Employee Name	Per Diem	Classification	ST Hours	OT Hours	ST Rate	OT Rate	Surcharge	Amount
143660	Cantu, Hector	No	Skilled Laborer	0.00	12.00	\$34.00	\$47.10	\$0.00	\$565.20
139137	Gonzalez, Miguel	No	Skilled Laborer	0.00	12.00	\$34.00	\$47.10	\$0.00	\$565.20

Subtotal: \$1,130.40

Number	Per Diem	Rate	Surcharge	Amount

Subtotal: \$0.00

Equipment Name	Fleet Asset ID	Hours/Day	Rate	PO No	Vendor Name	Surcharge	Amount
Trailer - Bumper Pull Utility	S10-MS68	1.00	\$86.00			\$0.00	\$86.00
Truck - 1/2 to 3/4 ton	S12-F447	12.00	\$30.00			\$0.00	\$360.00

Subtotal: \$446.00

Material Name	Vendor Name	PO No	Cost	Mark Up	Sales Tax	Surcharge	Amount

Subtotal: \$0.00

Supervisor Signature X \_\_\_\_\_

Approval Signature X \_\_\_\_\_

Total: \$1,576.40

Last Modified: 11/26/2019 3:57:43 PM

COPY





**Daily Labor & Equipment Time Ticket**

Date: 11/25/2019

Ticket No: 893934

Client: Lonestar Pipeline Company, LLC      Location: HIDALGO      Job No: 104-190032.095  
 Other: 17MH033

DE-WATERED THE 8" PL. PUSHED PIG. TIED IN TO PIPE ON EAST SIDE. FINISHED THE WEST TIE IN. BLASTED IN COATED BOTH ENDS. PULLED OUT EXISTING PIPE FROM CASING.

Combo Rate Description	Combo ID	ST Hours	OT Hours	ST Rate	OT Rate	Surcharge	Amount
<b>Subtotal:</b>							<b>\$0.00</b>

Emp No.	Employee Name	Per Diem	Classification	ST Hours	OT Hours	ST Rate	OT Rate	Surcharge	Amount
108210	Rocha, Hernan	No	Superintendent B	8.00	2.00	\$78.31	\$112.98	\$0.00	\$852.44
132411	Rios, Jorge Luis	No	Equipment Operator - A	8.00	2.00	\$57.74	\$82.39	\$0.00	\$626.70
147853	Guerra, Fabian	No	Foreman - Labor	8.00	2.00	\$49.82	\$70.63	\$0.00	\$539.82
136337	Perez, Ivan	No	Welder - Certified (w/o Rig)	8.00	2.00	\$75.15	\$108.28	\$0.00	\$817.76
121491	Arevalo, Heriberto	No	Craft Helper - B	8.00	2.00	\$35.58	\$49.45	\$0.00	\$383.54
107287	Cottrell, Brandon Stewart	No	Skilled Laborer	8.00	2.00	\$34.00	\$47.10	\$0.00	\$366.20
143660	Cantu, Hector	No	Skilled Laborer	8.00	2.00	\$34.00	\$47.10	\$0.00	\$366.20
147812	Cantu, Norberto	No	Skilled Laborer	8.00	2.00	\$34.00	\$47.10	\$0.00	\$366.20
139137	Gonzalez, Miguel	No	Skilled Laborer	8.00	2.00	\$34.00	\$47.10	\$0.00	\$366.20
139597	Molina, Amado	No	Craftsman - A	8.00	2.00	\$52.99	\$75.33	\$0.00	\$574.58
<b>Subtotal:</b>									<b>\$5,259.64</b>

Number	Per Diem	Rate	Surcharge	Amount
<b>Subtotal:</b>				<b>\$0.00</b>

Equipment Name	Fleet Asset ID	Hours/Day	Rate	PO No	Vendor Name	Surcharge	Amount
Truck - Contract Operator/Straw Pickup		10.00	\$20.00			\$0.00	\$200.00
Truck - 1 Ton (Weld Rig)		10.00	\$36.00			\$0.00	\$360.00
Truck - 1/2 to 3/4 ton	S19-F1790	10.00	\$30.00			\$0.00	\$300.00
Truck - 1/2 to 3/4 ton	S12-F447	10.00	\$30.00			\$0.00	\$300.00
Truck - 1/2 to 3/4 ton	S19-F1732	10.00	\$80.00			\$0.00	\$800.00
Excavator - 20 to 24 Metric Ton - (Machine with Standard	S19-EX982	10.00	\$99.00			\$0.00	\$990.00
Rubber Tire Backhoe (Machine with Standard Bucket)	C08-BL114	10.00	\$43.00			\$0.00	\$430.00
Air Compressors - 185 CFM	S17-AC190	1.00	\$254.00			\$0.00	\$254.00
<b>Subtotal:</b>							<b>\$3,134.00</b>

Material Name	Vendor Name	PO No	Cost	Mark Up	Sales Tax	Surcharge	Amount
<b>Subtotal:</b>							<b>\$0.00</b>

Supervisor Signature: \_\_\_\_\_ X \_\_\_\_\_  
 Approval Signature: \_\_\_\_\_ X \_\_\_\_\_

**Total: \$8,393.64**

Date: 11-25-19 Ticket No: 893934  
 Job No: 104-14032-95 Strike City: Hidalgo  
 Client Name: Lone star Location Site Name: Hidalgo County: Hidalgo  
 Project Name: Dricker Rd AFE/PID: PO:17mh033 State: TX

Description of Work  
Di-watered the 8" pipe, pushed pipe. Tied-in to pipe on east side. finished the west tie-in. Blasted in coated both ends. Pulled out existing pipe from casing.

Emp. No.	Employee Name	Classification	ST Hrs	OT Hrs	P.Dem	I-Rem	Amount
108210	Herman Rocha	Supt B	8	2			
132411	Jorge Rios	Operator	8	2		X	
147853	Fabian Guerra	Straw Boss	8	2			
136337	Ivan Perez	welder	8	2		X	
121491	Heriberto	w/Help	8	2			
107287	Brandon Cottrel	Slabor	8	2			
143660	Hector Cantu	Slabor	8	2			
147812	Norberto Cantu	Slabor	8	2			
139137	Miguel Gonzalez	Slabor	8	2			
139597	Arnaldo Molina	Craftman A	8	2			
Subtotal							

Equipment Description	Unit No.	Hours/Days	Amount
3/4 ton truck	Jorge Rios	10	
welding rig	Ivan Perez	10	
3/4 ton truck	S19-F1790	10	
3/4 ton truck	S12-F447	10	
3/4 ton paint rig	S19-F1732	10	
excavator	S19-EX992	10	
Back hoe	C08-R114	10	
ac compressor	S17-AC190	10 days	
Subtotal			

Material/Subs/Rental Desc.	Vendor	Inv. No.	PO#	Amount
Subtotal				

Supervisor Signature X [Signature]  
 Approval Signature X [Signature] 11/26/19  
 Total



**Daily Labor & Equipment Time Ticket**

Date: 11/26/2019

Ticket No: 893935

Client: Lonestar Pipeline Company, LLC      Location: HIDALGO      Job No: 104-190032.095

Other: 17MH033

CUT EXISTING PIPE INTO 30 FT SECTIONS WITH TORCH. OPERATOR BACK FILLED ON COMPACTED BOTH BELL HOLES. POURED FLOWABLE FILL ON BOTH TIE IN POINTS.

Combo Rate Description	Combo ID	ST Hours	OT Hours	ST Rate	OT Rate	Surcharge	Amount

**Subtotal: \$0.00**

Emp No.	Employee Name	Per Diem	Classification	ST Hours	OT Hours	ST Rate	OT Rate	Surcharge	Amount
108210	Rocha, Hernan	No	Superintendent B	8.00	2.00	\$78.31	\$112.98	\$0.00	\$852.44
132411	Rios, Jorge Luis	No	Equipment Operator - A	8.00	2.00	\$57.74	\$82.39	\$0.00	\$626.70
147853	Guerra, Fabian	No	Foreman - Labor	8.00	2.00	\$49.82	\$70.63	\$0.00	\$539.82
136337	Perez, Ivan	No	Welder - Certified (w/o Rig)	8.00	2.00	\$75.15	\$108.28	\$0.00	\$817.76
121491	Arevalo, Heriberto	No	Craft Helper - B	8.00	2.00	\$35.58	\$49.45	\$0.00	\$383.54
107287	Cottrell, Brandon Stewart	No	Skilled Laborer	8.00	2.00	\$34.00	\$47.10	\$0.00	\$366.20
143660	Cantu, Hector	No	Skilled Laborer	8.00	2.00	\$34.00	\$47.10	\$0.00	\$366.20
147812	Cantu, Norberto	No	Skilled Laborer	8.00	2.00	\$34.00	\$47.10	\$0.00	\$366.20
139137	Gonzalez, Miguel	No	Skilled Laborer	8.00	2.00	\$34.00	\$47.10	\$0.00	\$366.20
139597	Molina, Amado	No	Craftsman - A	8.00	2.00	\$52.99	\$75.33	\$0.00	\$574.58

**Subtotal: \$5,259.64**

Number	Per Diem	Rate	Surcharge	Amount

**Subtotal: \$0.00**

Equipment Name	Fleet Asset ID	Hours/Day	Rate	PO No	Vendor Name	Surcharge	Amount
Truck - Contract Operator/Straw Pickup		10.00	\$20.00			\$0.00	\$200.00
Truck - 1 Ton (Weld Rig)		10.00	\$36.00			\$0.00	\$360.00
Truck - 1/2 to 3/4 ton	S19-F1790	10.00	\$30.00			\$0.00	\$300.00
Truck - 1/2 to 3/4 ton	S12-F447	10.00	\$30.00			\$0.00	\$300.00
Truck - 1/2 to 3/4 ton	S19-F1732	10.00	\$30.00			\$0.00	\$300.00
Excavator - 20 to 24 Metric Ton - (Machine with Standard	S19-EX982	10.00	\$99.00			\$0.00	\$990.00
Rubber Tire Backhoe (Machine with Standard Bucket)	Q08-BL114	10.00	\$43.00			\$0.00	\$430.00
Skid Steer Mini Loader	S17-SS48	10.00	\$56.00			\$0.00	\$560.00

**Subtotal: \$3,440.00**

Material Name	Vendor Name	PO No	Cost	Mark Up	Sales Tax	Surcharge	Amount

**Subtotal: \$0.00**

Supervisor Signature      X \_\_\_\_\_

Approval Signature      X \_\_\_\_\_

**Total: \$8,699.64**





**Daily Labor & Equipment Time Ticket**

Date: 11/27/2019

Ticket No: 893936

Client: Lonestar Pipeline Company, LLC Location: HIDALGO Job No: 104-190032.095

Other: 17MH033  
 LOADED OLD CUT SECTIONS OF 30 FT JOINTS TO GOOSENECK. BACK FILLED AND COMPACTED WITH SOIL AND CALICHE. PICKED UP ALL TRAFFIC SIGNS.

Combo Rate Description	Combo ID	ST Hours	OT Hours	ST Rate	OT Rate	Surcharge	Amount

**Subtotal: \$0.00**

Emp No.	Employee Name	Per Diem	Classification	ST Hours	OT Hours	ST Rate	OT Rate	Surcharge	Amount
108210	Rocha, Hernan	No	Superintendent B	8.00	2.00	\$78.31	\$112.98	\$0.00	\$852.44
132411	Rios, Jorge Luis	No	Equipment Operator - A	8.00	2.00	\$57.74	\$82.39	\$0.00	\$626.70
147853	Guerra, Fabian	No	Foreman - Labor	8.00	2.00	\$49.82	\$70.63	\$0.00	\$539.82
139137	Gonzalez, Miguel	No	Skilled Laborer	8.00	2.00	\$34.00	\$47.10	\$0.00	\$366.20
107287	Cottrell, Brandon Stewart	No	Skilled Laborer	8.00	2.00	\$34.00	\$47.10	\$0.00	\$366.20
143660	Cantu, Hector	No	Skilled Laborer	8.00	2.00	\$34.00	\$47.10	\$0.00	\$366.20
147812	Cantu, Norberto	No	Skilled Laborer	8.00	2.00	\$34.00	\$47.10	\$0.00	\$366.20
139597	Molina, Amado	No	Craftsman - A	8.00	2.00	\$52.99	\$75.33	\$0.00	\$574.58
121847	Salinas Garcia, Saturnino	No	Skilled Laborer	8.00	2.00	\$34.00	\$47.10	\$0.00	\$366.20
147005	Alaniz, Jesus Adrian	No	Truck Driver - A (Equipment Operator	8.00	2.00	\$54.57	\$77.69	\$0.00	\$591.94
148444	Alaniz, Jesus adrian	No	Skilled Laborer	8.00	2.00	\$34.00	\$47.10	\$0.00	\$366.20
124660	Garcia, Ricardo	No	Quality Associate	8.00	2.00	\$54.57	\$77.69	\$0.00	\$591.94

**Subtotal: \$5,974.62**

Number	Per Diem	Rate	Surcharge	Amount

**Subtotal: \$0.00**

Equipment Name	Fleet Asset ID	Hours/Day	Rate	PO No	Vendor Name	Surcharge	Amount
Truck - Contract Operator/Straw Pickup		10.00	\$20.00			\$0.00	\$200.00
Truck - 1/2 to 3/4 ton	S19-F1790	10.00	\$30.00			\$0.00	\$300.00
Truck - 1/2 to 3/4 ton	S12-F447	10.00	\$30.00			\$0.00	\$300.00
Truck - 1/2 to 3/4 ton	S19-F1732	10.00	\$30.00			\$0.00	\$300.00
Truck - 1 Ton (Double Rear Wheel)	S17-F1420	10.00	\$36.00			\$0.00	\$360.00
Trailer - Gooseneck Tandem Axle	S07-AT27	1.00	\$116.00			\$0.00	\$116.00
Excavator - 20 to 24 Metric Ton - (Machine with Standard	S19-EX982	10.00	\$99.00			\$0.00	\$990.00
Rubber Tire Backhoe (Machine with Standard Bucket)	C08-BL114	10.00	\$43.00			\$0.00	\$430.00
Skid Steer Mini Loader	S17-SS48	10.00	\$56.00			\$0.00	\$560.00
Truck - Contract Operator/Straw Pickup		10.00	\$20.00			\$0.00	\$200.00

**Subtotal: \$3,756.00**

Material Name	Vendor Name	PO No	Cost	Mark Up	Sales Tax	Surcharge	Amount

**Subtotal: \$0.00**

Supervisor Signature X \_\_\_\_\_

Approval Signature X \_\_\_\_\_

**Total: \$9,730.62**





Daily Labor & Equipment Time Ticket

Date: 12/02/2019

Ticket No: 5166456

Client Lonestar Pipeline Company, LLC Location: MCALLEN Job No: 104-190032.095

Other: 17MH033

PO RENTAL VACTRON.

Combo Rate Description	Combo ID	ST Hours	OT Hours	ST Rate	OT Rate	Surcharge	Amount

Subtotal: \$0.00

Emp No.	Employee Name	Per Diem	Classification	ST Hours	OT Hours	ST Rate	OT Rate	Surcharge	Amount

Subtotal: \$0.00

Number	Per Diem	Rate	Surcharge	Amount

Subtotal: \$0.00

Equipment Name	Fleet Asset ID	Hours/Day	Rate	PO No	Vendor Name	Surcharge	Amount

Subtotal: \$0.00

Material Name	Vendor Name	PO No	Cost	Mark Up	Sales Tax	Surcharge	Amount
VACTRON RENTAL DELIVERY/PICKUP	UNITED RENTALS INC	104643309	-\$167.02	-\$30.06	-\$13.78	\$0.00	-\$210.86

Subtotal: -\$210.86

Supervisor Signature X \_\_\_\_\_

Approval Signature X \_\_\_\_\_

Total: -\$210.86

Last Modified: 12/2/2019 9:14:35 AM

COOP





BRANCH P49  
 3925 N. CAGE BLVD  
 PHARR TX 78577-8041  
 956-787-9590  
 956-702-0621 FAX

RENTAL  
 CREDIT MEMO

# 175747844-002

Job Site

HIDALGO JOB  
 10TH DICKER RD  
 x:10TH@DICKER RD  
 HIDALGO TX 78557  
**Office:** 713-389-3235 **Cell:** 346-334-3981

Customer #	: 1133190
Credit Date	: 11/06/19
Credit Inv	: 175747844-001
UR Job Loc	: 10TH DICKER RD, HIDA
UR Job #	: 2741
Customer Job ID:	
P.O. #	: 104643309
Requested By	: RICARDO GARCIA
Approved By	: ADAM TORRES
Salesperson	: RAUL GONZALEZ JR

STRIKE LLC  
 STE 500  
 1800 HUGHES LANDING BLVD  
 THE WOODLANDS TX 77380-1684

**Invoice Amount: \$180.80-**

Terms: Net 60 Days  
 Payment options: Contact our credit office 704-916-4825  
**REMIT TO:** UNITED RENTALS (NORTH AMERICA),INC.  
 PO BOX 840514  
 DALLAS TX 75284-0514

RENTAL ITEMS:

Qty	Equipment	Description	Minimum	Day	Week	4 Week	Amount
-----	-----------	-------------	---------	-----	------	--------	--------

SALES/MISCELLANEOUS ITEMS:

Qty	Item	Price	Unit of Measure	Extended Amt.
1	PICKUP CHARGE	167.020-	EACH	167.02-
Rental Subtotal:				167.02-
Sales/Misc Subtotal:				167.02-
Agreement Subtotal:				167.02-
Tax:				13.78-
Total:				180.80-

COMMENTS/NOTES:

CONTACT: RICARDO GARCIA  
 CELL#: 346-334-3981





# INVOICE

**Invoice No:** F00177218  
**Invoice Date:** January 06, 2020  
**Payment Terms:** Net 30  
**Contract No:**  
**Reference:** 104-190032: Dicker Road HDD

**Location:** Dicker Road HDD  
**PO:**  
**AFE:**  
**WO:**  
**Other:** 17MH033

**To:** Lonestar Pipeline Company, LLC  
 c/o AP  
 c/o Kindle Energy LLC  
 500 Alexander Park Drive, Suite 300  
 Princeton, New Jersey 08540

**Remit To:** Strike, LLC  
 PO Box 844338  
 Dallas, TX 75284-4338  
  
**Or**  
**Wire:** Bank of America  
 ABA #026009593  
**ACH:** ABA #111000012  
 Strike, LLC  
 Account #4451217749

**Description:** PO'S. MOVING EXCAVATOR FROM LOCATION. WELD MAP, JOB BOOK. WENT AND BOUGHT WHITE PAINT. PLACED PIPE ON JACK STANDS AND CLEANED PIPE TO PREP FOR PAINT. PAINTED PIPE. AFTER PIPE WAS DRY WE WROTE HEAT #'S ON PIPE AND RELOCATED IT TO THE EAST SIDE OF THE YARD FOR STORAGE.

Ticket No.	Ticket Date	Labor	Equipment	Materials	Per Diem	Total
893488	11/26/2019	\$0.00	\$0.00	\$43,149.74	\$0.00	\$43,149.74
893937	12/2/2019	\$591.94	\$200.00	\$12,614.20	\$0.00	\$13,406.14
373908	12/10/2019	\$1,324.34	\$200.00	\$618.58	\$0.00	\$2,142.92
		\$1,916.28	\$400.00	\$56,382.52	\$0.00	\$58,698.80

*Non-taxable Subtotal including any Discounts* \$58,698.80  
*Taxable Subtotal including any Discounts* \$0.00  
 Sales Tax :: State Of Texas- 440000000 :: 6.25% \$0.00  
**Sales Tax Subtotal** \$0.00

**Total Invoice Due:** **\$58,698.80**

TxDOT  
Reimbursable



## INVOICE SUMMARY

### LABOR

Classification Description	Standard Hours	Hourly Rate	Overtime Hours	Overtime Rate	Standard Total	Overtime Total	Surcharge	Labor Total
Quality Associate	8.00	\$54.57	2.00	\$77.69	\$436.56	\$155.38	\$0.00	\$591.94
Skilled Laborer	16.00	\$34.00	4.00	\$47.10	\$544.00	\$188.40	\$0.00	\$732.40
Truck Driver - A (Equipment Operator w/ CDL)	8.00	\$54.57	2.00	\$77.69	\$436.56	\$155.38	\$0.00	\$591.94
<b>Labor Total</b>	<b>32.00</b>		<b>8.00</b>		<b>\$1,417.12</b>	<b>\$499.16</b>	<b>\$0.00</b>	<b>\$1,916.28</b>

### EQUIPMENT

Equipment Name	Quantity	Rate	Amount	Surcharge	Equipment Total
Truck - Contract Operator/Straw Pickup	20.00	\$20.00	\$400.00	\$0.00	\$400.00
<b>Equipment Total</b>			<b>\$400.00</b>	<b>\$0.00</b>	<b>\$400.00</b>

### PER DIEM

	Quantity	Rate	Amount	Surcharge	Per Diem Total
<b>Per Diem Total</b>			<b>\$0.00</b>	<b>\$0.00</b>	<b>\$0.00</b>

### MATERIAL

Material Name	Mark up	Cost	SalesTax	Amount	Surcharge	Material Total
PORTABLE RESTROOM	\$127.12	\$454.00	\$37.46	\$491.46	\$0.00	\$618.58
HAUL DIRT AND DISPOSAL	\$598.50	\$3,325.00	\$0.00	\$3,325.00	\$0.00	\$3,923.50
GRAVEL AND COAL MIX	\$526.50	\$2,925.00	\$0.00	\$2,925.00	\$0.00	\$3,451.50
CALICHE	\$364.50	\$2,025.00	\$0.00	\$2,025.00	\$0.00	\$2,389.50
TRANSPORT PIPE	\$289.80	\$1,610.00	\$0.00	\$1,610.00	\$0.00	\$1,899.80
HAULING EQUIPMENT	\$144.90	\$805.00	\$0.00	\$805.00	\$0.00	\$949.90
DIRECTIONAL DRILL	\$6,246.00	\$34,700.00	\$0.00	\$34,700.00	\$0.00	\$40,946.00
FLOWABLE FILL	\$171.72	\$954.00	\$72.72	\$1,026.72	\$0.00	\$1,198.44
TRAFFIC CONTRL SIGNS	\$219.91	\$785.39	\$0.00	\$785.39	\$0.00	\$1,005.30
<b>Material Total</b>	<b>\$8,688.95</b>		<b>\$110.18</b>	<b>\$47,693.57</b>	<b>\$0.00</b>	<b>\$56,382.52</b>

Non-Taxable Subtotal	\$58,698.80
Taxable Subtotal	\$0.00
Sales Tax Subtotal	\$0.00
<b>Total Invoice Due</b>	<b>\$58,698.80</b>



**Daily Labor & Equipment Time Ticket**

Date: 11/26/2019 Ticket No: 893488

Client: Lonestar Pipeline Company, LLC Location: HIDALGO Job No: 104-190032.095  
 Other: 17MH033

PO'S:  
 \_\_\_\_\_  
 \_\_\_\_\_  
 \_\_\_\_\_

Combo Rate Description	Combo ID	ST Hours	OT Hours	ST Rate	OT Rate	Surcharge	Amount
<b>Subtotal:</b>							<b>\$0.00</b>

Emp No.	Employee Name	Per Diem	Classification	ST Hours	OT Hours	ST Rate	OT Rate	Surcharge	Amount
<b>Subtotal:</b>									<b>\$0.00</b>

Number	Per Diem	Rate	Surcharge	Amount
<b>Subtotal:</b>				<b>\$0.00</b>

Equipment Name	Fleet Asset ID	Hours/Day	Rate	PO No	Vendor Name	Surcharge	Amount
<b>Subtotal:</b>							<b>\$0.00</b>

Material Name	Vendor Name	PO No	Cost	Mark Up	Sales Tax	Surcharge	Amount
FLOWABLE FILL	CEMEX	104649356	\$954.00	\$171.72	\$72.72	\$0.00	\$1,198.44
DIRECTIONAL DRILL	COASTAL DIRECTIONAL	104649606	\$34,700.00	\$6,246.00	\$0.00	\$0.00	\$40,946.00
TRAFFIC CONTRL SIGNS	TEXAS HIGHWAY		\$785.39	\$219.91	\$0.00	\$0.00	\$1,005.30
<b>Subtotal:</b>							<b>\$43,149.74</b>

Supervisor Signature X \_\_\_\_\_

Approval Signature X \_\_\_\_\_

**Total: \$43,149.74**

Last Modified: 12/12/2019 10:44:52 AM

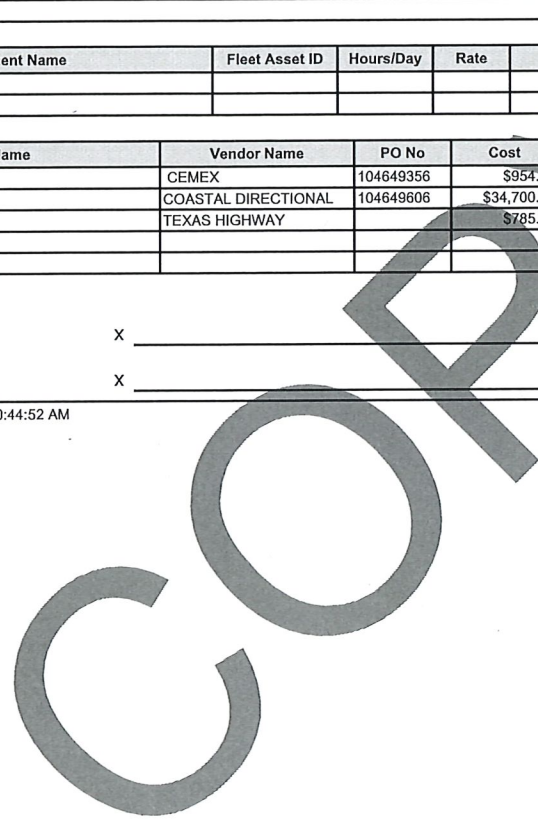



CEMEX  
10100 Katy Freeway Ste 300  
Houston, TX 77043-5267

CEMEX Construction Materials South, LLC

# INVOICE

Date: 11/26/2019  
 Invoice No: 9440926351  
 Terms: Net 20th prox  
 Payment Due On: 12/20/2019  
 Territory Manager: -NORRIS, TRAVIS P  
 Job No: 14823652  
 Legal Address: SOUTH 10TH & DICKER RD.  
 Customer Job No. 104-190032-95  
 Account No: 3143750  
 Account Name: STRIKE LLC



INV2\_INS ▲ 000101  
 STRIKE LLC  
 1800 HUGHES LANDING BLVD STE 500  
 THE WOODLANDS TX 77380-1684

**For All Inquiries Call:**  
713-650-6200

**Remit To:**  
CEMEX | PO Box 730197 | Dallas, TX 75373-0197

## DETAILED INFORMATION BY PO

PO Number: 104-190032-95			DELIVERY ADDRESS: SOUTH 10TH & DICKER RD., MCALLEN, TX, 78504								
Ship Date	Delivery	Ref #	Product Code / Description	Qty	UOM	Net Price By UOM		Units	Amount	Freight	Tx
11/26/2019	8085850237	45471918	1202749 ENVIRONMENTAL CHARGE PER LOAD	1.000	EA	\$10.00	1 PC	1.000	\$10.00	\$0.00	T
11/26/2019	8085850237	45471918	1247817 STANDARD FUEL SURCHARGE	1.000	EA	\$10.00	1 PC	1.000	\$10.00	\$0.00	T
11/26/2019	8085850237	45471918	1421064 RECOVER 2	9.000	DOS	\$10.00	1 DOS	9.000	\$90.00	\$0.00	T
11/26/2019	8085850237	45471918	1607278 TXDOT 3SK FLOWFILL VICTORIA	9.000	YD3	\$106.00	1 YD3	9.000	\$954.00	\$0.00	T
<b>PO Subtotal</b>	<b>9.00 Yards</b>		<b>0.00 Tons</b>			<b>\$1,064.00 Material</b>			<b>\$0.00 Freight</b>		
						<b>\$0.00 Other</b>		<b>\$87.80 Tax</b>		<b>\$1,151.80 Total</b>	

<b>9.00 Yards</b>	<b>0.00 Tons</b>	<b>\$0.00 Freight</b>	<b>\$0.00 Other</b>	<b>\$87.80 Tax</b>	<b>\$1,151.80 Invoice Total</b>
-------------------	------------------	-----------------------	---------------------	--------------------	---------------------------------

The invoice incorporates herein by reference Buyer's previously executed Credit Application, if any, Sellers Standard Terms and Conditions, Seller's Quotation and Seller's Order Confirmation (including limitations of warranties) as fully set forth on this Invoice ("Agreement"). Buyer agrees that, unless otherwise noted herein, all quantities and items were delivered as indicated and further expressly agrees to pay in accordance with this Agreement. Interest shall accrue on late payments.

Coastal Directional Drilling, Inc.

415 N. Vineyard St  
TX 78387

# Invoice

Date	Invoice #
11/25/2019	542

<b>Bill To</b>
Strike LLC 1800Hughs Landing BLVD Suite 500 The Woodlands, Texas 77380

P.O. No.	Terms	Project
	Net 30	1006.1

Quantity	Description	Rate	Amount
600	Bore 18" Hole	52.00	31,200.00
1	Mob In and Out	3,500.00	3,500.00
	Sales Tax	8.25%	0.00
		<b>Total</b>	<b>\$34,700.00</b>

<b>Phone #</b>
3613649113



Square automatically sends receipts to the email address you used at any Square seller. [Learn more](#)



Texas Highway Systems, Inc

How was your experience?



\$785.39

Custom Amount	\$785.39
<b>Total</b>	<b>\$785.39</b>

Phone



Texas Highway Systems, Inc  
Po Box 2687  
Edinburg, TX 78540  
956-580-7660



MasterCard 6237  
(Keyed)

Nov 27 2019 at 9:55 AM

#OhfZ

Auth code: 810553

© 2019 Square, Inc

1455 Market Street, Suite 600  
San Francisco, CA 94103

© Mapbox © OpenStreetMap Improve this map

[Square Privacy Policy](#) | [Not your receipt?](#)  
[Manage preferences](#) for digital receipts



**Texas Highway Systems, Inc**  
**PO Box 2687**  
**Edinburg, TX 78540**  
**956-580-7660 Office**

**Invoice**

Date	Invoice #
11/29/2019	1129-5628C

Bill To
STRIKE CONSTRUCTION 1800 Hughes Landing Blvd #500 The Woodlands, TX 77380

Project
Dicker Road 11/14/19

P.O. No.	Terms
Ricardo	Net 30

Qty	Description	Price Each	Amount
1	Daily Rental - \$50/day x 14 days	700.00	700.00
1	Credit Card Fee	27.64	27.64
	Off rent 11/27		

COPY

**956-207-4385 BJ Ozuna (cell)**  
**office@TexasHighwaySystems.com**  
**1907 N. Alton Blvd - shop**  
**WWW.TEXASHIGHWAYSYSTEMS.COM**

<b>Subtotal</b>	\$727.64
<b>Sales Tax (8.25%)</b>	\$57.75
<b>Balance Due</b>	\$785.39





**Daily Labor & Equipment Time Ticket**

Date: 12/02/2019

Ticket No: 893937

Client Lonestar Pipeline Company, LLC Location: HIDALGO Job No: 104-190032.095

Other: 17MH033

MOVING EXCAVATOR FROM LOCATION. WELD MAP , JOB BOOK.

Combo Rate Description	Combo ID	ST Hours	OT Hours	ST Rate	OT Rate	Surcharge	Amount
<b>Subtotal:</b>							<b>\$0.00</b>

Emp No.	Employee Name	Per Diem	Classification	ST Hours	OT Hours	ST Rate	OT Rate	Surcharge	Amount
124660	Garcia, Ricardo	No	Quality Associate	8.00	2.00	\$54.57	\$77.69	\$0.00	\$591.94
<b>Subtotal:</b>									<b>\$591.94</b>

Number	Per Diem	Rate	Surcharge	Amount
<b>Subtotal:</b>				<b>\$0.00</b>

Equipment Name	Fleet Asset ID	Hours/Day	Rate	PO No	Vendor Name	Surcharge	Amount
Truck - Contract Operator/Straw Pickup		10.00	\$20.00			\$0.00	\$200.00
<b>Subtotal:</b>							<b>\$200.00</b>

Material Name	Vendor Name	PO No	Cost	Mark Up	Sales Tax	Surcharge	Amount
HAULING EQUIPMENT	TEXAN DUMP TRUCKS	104650719	\$805.00	\$144.90	\$0.00	\$0.00	\$949.90
GRAVEL AND COAL MIX	TEXAN DUMP TRUCKS	104649781	\$2,925.00	\$526.50	\$0.00	\$0.00	\$3,451.50
TRANSPORT PIPE	TEXAN DUMP TRUCKS	104649792	\$1,610.00	\$289.80	\$0.00	\$0.00	\$1,899.80
HAUL DIRT AND DISPOSAL	TEXAN DUMP TRUCKS	104649794	\$3,325.00	\$598.50	\$0.00	\$0.00	\$3,923.50
CALICHE	TEXAN DUMP TRUCKS	104649796	\$2,025.00	\$364.50	\$0.00	\$0.00	\$2,389.50
<b>Subtotal:</b>							<b>\$12,614.20</b>

Supervisor Signature X \_\_\_\_\_

Approval Signature X \_\_\_\_\_

<b>Total:</b>	<b>\$13,406.14</b>
---------------	--------------------

Last Modified: 12/27/2019 4:11:39 PM

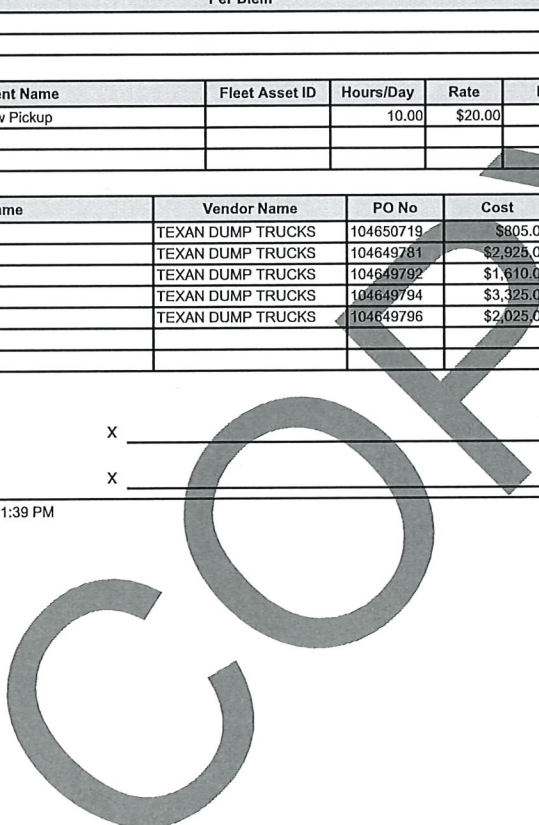



TEXAN DUMP TRUCKS & CONSTRUCTION  
P.O. BOX 869  
Edinburg, TX 78540  
texandumptrucks@yahoo.com

# Invoice

**BILL TO**

STRIKE, LLC  
1800 Hughes Landing Blvd., Suite  
500  
The Woodlands, TX. 77380

**SHIP TO**

Lonestar Project  
Penitas, TX

INVOICE #	DATE	TOTAL DUE	DUE DATE	TERMS	ENCLOSED
17562	12/04/2019	\$805.00	01/03/2020	Net 30	

P.O. NO  
104650719

DESCRIPTION	QTY	RATE	AMOUNT
Tractor Trailer Lowboy -Transport track hoe from Lonestar Project, 10th and Dicker, Hidalgo, TX to Penitas, TX	7	115.00	805.00

Thank you for your business.

BALANCE DUE

**\$805.00**

COPY



TEXAN DUMP TRUCKS & CONSTRUCTION  
P.O. BOX 869  
Edinburg, TX 78540  
texandumptrucks@yahoo.com

# Invoice

**BILL TO**  
STRIKE, LLC  
1800 Hughes Landing Blvd., Suite  
500  
The Woodlands, TX. 77380

**SHIP TO**  
Strike Yard  
Mission, TX

INVOICE #	DATE	TOTAL DUE	DUE DATE	TERMS	ENCLOSED
17559	11/27/2019	\$1,610.00	12/27/2019	Net 30	

**SHIP DATE**  
11/27/2019

**P.O. NO**  
104649792

DESCRIPTION	QTY	RATE	AMOUNT
Tractor Trailer Flat Bed -Transport 8" pipe from Lonestar Project, 10th and Dicker, Hidalgo, TX to Strike Yard, Mission, TX	14	115.00	1,610.00

Thank you for your business.

**BALANCE DUE**

**\$1,610.00**

COPY



TEXAN DUMP TRUCKS & CONSTRUCTION  
P.O. BOX 869  
Edinburg, TX 78540  
texandumptrucks@yahoo.com

# Invoice

**BILL TO**

STRIKE, LLC  
1800 Hughes Landing Blvd., Suite  
500  
The Woodlands, TX. 77380

**SHIP TO**

Lonestar Project  
10th & Dicker  
Hidalgo, TX

INVOICE #	DATE	TOTAL DUE	DUE DATE	TERMS	ENCLOSED
17560	11/27/2019	\$2,025.00	12/27/2019	Net 30	

**SHIP DATE**  
11/27/2019

**P.O. NO**  
104649796

DESCRIPTION	QTY	RATE	AMOUNT
3 loads of crushed caliche base delivered to Lonestar Project, 10th & Dicker, Hidalgo, TX	3	675.00	2,025.00

Thank you for your business.

BALANCE DUE

**\$2,025.00**

COPY



TEXAN DUMP TRUCKS & CONSTRUCTION  
P.O. BOX 869  
Edinburg, TX 78540  
texandumptrucks@yahoo.com

# Invoice

**BILL TO**  
STRIKE, LLC  
1800 Hughes Landing Blvd., Suite  
500  
The Woodlands, TX. 77380

**SHIP TO**  
Lonestar Project  
10th & Dicker  
Hidalgo, TX

INVOICE #	DATE	TOTAL DUE	DUE DATE	TERMS	ENCLOSED
17558	11/27/2019	\$2,925.00	12/27/2019	Net 30	

**SHIP DATE**  
11/26/2019

**P.O. NO**  
104649781

DESCRIPTION	QTY	RATE	AMOUNT
Lonestar Project 1 load of pea gravel	1	975.00	975.00
1.5 in gravel	1	975.00	975.00
1 load of coal mix milling	1	975.00	975.00
10th and Dicker Hidalgo TX			

Thank you for your business.

BALANCE DUE

**\$2,925.00**

COPY



TEXAN DUMP TRUCKS & CONSTRUCTION  
P.O. BOX 869  
Edinburg, TX 78540  
texandumptrucks@yahoo.com

# Invoice

**BILL TO**  
STRIKE, LLC  
1800 Hughes Landing Blvd., Suite  
500  
The Woodlands, TX. 77380

**SHIP TO**  
Texan Pit  
Mission, TX

INVOICE #	DATE	TOTAL DUE	DUE DATE	TERMS	ENCLOSED
17561	11/27/2019	\$3,325.00	12/27/2019	Net 30	

**SHIP DATE**  
11/27/2019

**P.O. NO**  
104649794

DESCRIPTION	QTY	RATE	AMOUNT
7 loads of dirt, haul off dirt and disposal from Lonestar Project, 10th & Dicker, Hidalgo, TX to Texan Pit, Mission, TX	7	475.00	3,325.00

Thank you for your business.

BALANCE DUE

**\$3,325.00**

COPY





**Daily Labor & Equipment Time Ticket**

Date: 12/10/2019

Ticket No: 373908

Client Lonestar Pipeline Company, LLC Location: MISSION TX Job No: 104-190032.095

Other: 17MH033

WENT AND BOUGHT WHITE PAINT. PLACED PIPE ON JACK STANDS AND CLEANED PIPE TO PREP FOR PAINT. PAINTED PIPE. AFTER PIPE WAS DRY WE WROTE HEAT #'S ON PIPE AND RELOCATED IT TO THE EAST SIDE OF THE YARD FOR STORAGE.

Combo Rate Description	Combo ID	ST Hours	OT Hours	ST Rate	OT Rate	Surcharge	Amount

**Subtotal: \$0.00**

Emp No.	Employee Name	Per Diem	Classification	ST Hours	OT Hours	ST Rate	OT Rate	Surcharge	Amount
147005	Alanis, Jesus Adrian	No	Truck Driver - A (Equipment Operator	8.00	2.00	\$54.57	\$77.69	\$0.00	\$591.94
148444	Alaniz, Jesus adrian	No	Skilled Laborer	8.00	2.00	\$34.00	\$47.10	\$0.00	\$366.20
131075	Rodriguez, Jose Luis	No	Skilled Laborer	8.00	2.00	\$34.00	\$47.10	\$0.00	\$366.20

**Subtotal: \$1,324.34**

Number	Per Diem	Rate	Surcharge	Amount

**Subtotal: \$0.00**

Equipment Name	Fleet Asset ID	Hours/Day	Rate	PO No	Vendor Name	Surcharge	Amount
Truck - Contract Operator/Straw Pickup		10.00	\$20.00			\$0.00	\$200.00

**Subtotal: \$200.00**

Material Name	Vendor Name	PO No	Cost	Mark Up	Sales Tax	Surcharge	Amount
PORTABLE RESTROOM	ELITE OIL FIELD &	104663298	\$454.00	\$127.12	\$37.46	\$0.00	\$618.58

**Subtotal: \$618.58**

Supervisor Signature X \_\_\_\_\_

Approval Signature X \_\_\_\_\_

**Total: \$2,142.92**

Last Modified: 12/19/2019 1:51:24 PM

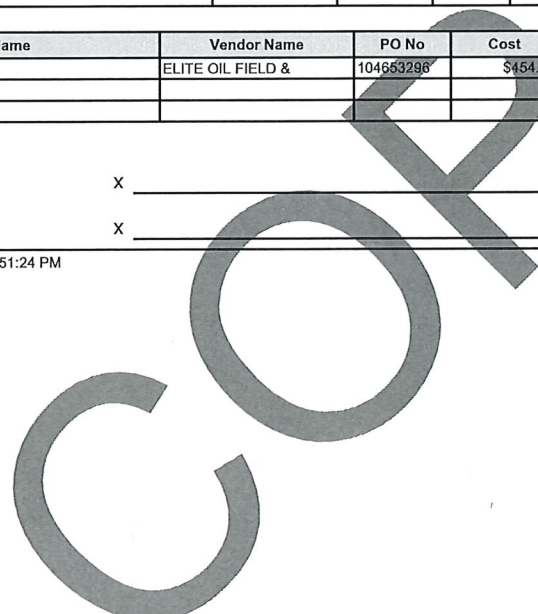



Elite Oilfield and Construction Services, LLC  
 PO BOX 2659  
 Edinburg, TX 78539  
 Office Ph: 956-584-0709  
 Fax# 1-888-349-9563

# Invoice

Invoice Date	Invoice #
12/02/2019	16814-Elite

E-mail customer.service@aneliteservice.com  
 Web Site aneliteservice.com

Bill To
Strike Construction 1800 Hughes Landing Blvd., Suite 500 The Woodlands, TX 77380

Company Man / Authorized Rep.
Steve Villarreal esteban.villarreal@strikeusa.com

Location	Terms	Purchase Order No.	Charge To	Start Date	End Date
Lone Star Bore	Net 30	104-653296		11/11/2019	12/02/2019
Qty	Item code	Description	Price Each	Amount	
1	Delivery/Setup	Delivery/ set up fee of portable restroom on 11/11/19.	95.00	95.00T	
1	Conventional restroom	Conventional Model Portable Restroom Rental. (\$12.00 per day) 22 days, 11/11/19 - 12/02/19.	264.00	264.00T	
1	Pick up	Pick up Portable restroom on 12/02/19. Sales Tax	95.00 8.25%	95.00T 37.46	

Thank you for your business

Customer Signature X \_\_\_\_\_

<b>Total</b>	\$491.46
--------------	----------





## INVOICE

<b>Invoice No:</b>	F00179477	<b>Location:</b>	Dicker Road HDD
<b>Invoice Date:</b>	January 30, 2020	<b>PO:</b>	
<b>Payment Terms:</b>	Net 30	<b>AFE:</b>	
<b>Contract No:</b>		<b>WO:</b>	
<b>Reference:</b>	104-190032: Dicker Road HDD	<b>Other:</b>	17MH033

**To:** Lonestar Pipeline Company, LLC  
 c/o AP  
 c/o Kindle Energy LLC  
 500 Alexander Park Drive, Suite 300  
 Princeton, New Jersey 08540

**Remit To:** Strike, LLC  
 PO Box 844338  
 Dallas, TX 75284-4338

**Or**  
**Wire:** Bank of America  
 ABA #026009593  
**ACH:** ABA #111000012  
 Strike, LLC  
 Account #4451217749

**Description:** DICKER RD SURVEY REBILL.

Ticket No.	Ticket Date	Labor	Equipment	Materials	Per Diem	Total
2901823	1/17/2020	\$0.00	\$0.00	\$3,996.90	\$0.00	\$3,996.90
		\$0.00	\$0.00	\$3,996.90	\$0.00	\$3,996.90

*Non-taxable Subtotal including any Discounts* \$3,996.90

*Taxable Subtotal including any Discounts* \$0.00

*Sales Tax :: State Of Texas- 440000000 :: 6.25%* \$0.00

**Sales Tax Subtotal** \$0.00

**Total Invoice Due:** **\$3,996.90**

TxDOT  
 Reimbursable



### INVOICE SUMMARY

#### LABOR

Classification Description	Standard Hours	Hourly Rate	Overtime Hours	Overtime Rate	Standard Total	Overtime Total	Surcharge	Labor Total
Labor Total	0.00		0.00		\$0.00	\$0.00	\$0.00	\$0.00

#### EQUIPMENT

Equipment Name	Quantity	Rate	Amount	Surcharge	Equipment Total
Equipment Total			\$0.00	\$0.00	\$0.00

#### PER DIEM

	Quantity	Rate	Amount	Surcharge	Per Diem Total
Per Diem Total			\$0.00	\$0.00	\$0.00

#### MATERIAL

Material Name	Mark up	Cost	SalesTax	Amount	Surcharge	Material Total
SURVEY	\$609.70	\$3,387.20	\$0.00	\$3,387.20	\$0.00	\$3,996.90
Material Total	\$609.70		\$0.00	\$3,387.20	\$0.00	\$3,996.90

Non-Taxable Subtotal	\$3,996.90
Taxable Subtotal	\$0.00
Sales Tax Subtotal	\$0.00
<b>Total Invoice Due</b>	<b>\$3,996.90</b>



**Daily Labor & Equipment Time Ticket**

Date: 01/17/2020

Ticket No: 2901823

**Client** Lonestar Pipeline Company, LLC    **Location:** STRIKE YARD    **Job No:** 104-190032.095

Other: 17MH033

DICKER RD SURVEY REBILL.

Combo Rate Description	Combo ID	ST Hours	OT Hours	ST Rate	OT Rate	Surcharge	Amount

**Subtotal:** \$0.00

Emp No.	Employee Name	Per Diem	Classification	ST Hours	OT Hours	ST Rate	OT Rate	Surcharge	Amount

**Subtotal:** \$0.00

Number	Per Diem	Rate	Surcharge	Amount

**Subtotal:** \$0.00

Equipment Name	Fleet Asset ID	Hours/Day	Rate	PO No	Vendor Name	Surcharge	Amount

**Subtotal:** \$0.00

Material Name	Vendor Name	PO No	Cost	Mark Up	Sales Tax	Surcharge	Amount
SURVEY			\$3,387.20	\$609.70	\$0.00	\$0.00	\$3,996.90

**Subtotal:** \$3,996.90

Supervisor Signature            X \_\_\_\_\_

Approval Signature            X \_\_\_\_\_

<b>Total:</b>	<b>\$3,996.90</b>
---------------	-------------------



2805 Fountain Plaza Blvd., Suite A  
 Edinburg, Texas 78539  
 (956) 603-2025

## Invoice

Date	Invoice #
1/17/2020	2020-04

Please send remittance with copy of invoice to:  
 Attn: Mr. Robert Macheska  
 2805 Fountain Plaza Blvd.  
 Suite A  
 Edinburg, Tx. 78539

Bill To:  
 Juan Salinas, Strike Construction LLC.  
 15000 I-35 South  
 Dilly, Texas 78017

Project Info:  
 10th Street & Dicker Road  
 Strike - LoneStar Construction Staking  
 Pipeline Crossing

**Billing Period**                      **November 2019**

Description	Contract	Previous Applications	Current Completed	Total Completed	% Complete
<b>Task 1</b> - Construction Staking & Callback*	\$ 2,612.20	\$ -	\$ 2,612.20	\$ 2,612.20	100.0%
<b>Task 2</b> - Engineering QAQC for CAD Files Project Engineer - 5 Hours @ \$144/Hr = \$576.00 Admin - 1 Hour @ \$55/Hr	\$ 775.00	\$ -	\$ 775.00	\$ 775.00	100.0%

\*Invoice attached

**Total For This Billing Period**                      **\$3,387.20**

Contract ~ Summary

Contract No.	Contract Amount	Previously Inv.	Percent Complete	Remaining Balance
N/A	\$3,387.20	\$0.00	100.0%	\$0.00

Robert Macheska - Exec. VP/COO



# VICKREY & ASSOCIATES, INC. CONSULTING ENGINEERS

12940 Country Parkway San Antonio, Texas 78216 210-349-3271

January 9, 2020

Project No: 2917-001

Invoice No: 108544

Yvonne Leija  
GDJ Engineering, LLC  
2805 Fountain Plaza Blvd., Suite A  
Edinburg 78539

Project 2917-001 10th St./Dicker Rd. Staking (Lone Star)

Email invoices to: Yvonne@GDJeng.com

**Professional Services For Period Ending December 22, 2019**

Phase 110 Construction Staking - 10th/Dicker  
Includes Additional Services - Call back by Contractor Jerome Landry

**Professional Personnel**

	Hours	Rate	Amount	
Project Technician - A	.50	90.00	45.00	
Registered Prof. Land Surveyor	9.00	190.00	1,710.00	
Survey Technician II	6.00	100.00	600.00	
Totals	15.50		2,355.00	
<b>Total Labor</b>				<b>2,355.00</b>
		<b>Total this Phase</b>		<b>\$2,355.00</b>

Phase 999 Project Direct Costs

**Direct Expenses**

Supplies					
12/3/2019	AllTerra Central, Inc	R10 Rover w/Internal radio	257.20		
	<b>Total Direct Expenses</b>		<b>257.20</b>	<b>257.20</b>	
		<b>Total this Phase</b>		<b>\$257.20</b>	
		<b>Total this Invoice</b>		<b>\$2,612.20</b>	

**Billings to Date**

	Current	Prior	Total	Received	A/R Balance
Labor	2,355.00	0.00	2,355.00		
Expense	257.20	0.00	257.20		
<b>Totals</b>	<b>2,612.20</b>	<b>0.00</b>	<b>2,612.20</b>	<b>0.00</b>	<b>2,612.20</b>

Authorized By: \_\_\_\_\_

Kurt Schumacher

**PROFESSIONAL SERVICES AGREEMENT**

November 18, 2019

Mr. Robert Macheska, PE, COO  
GDJ Engineering  
**Attn.: Mr. Anthony Garza**  
285 Fountain Plaza Boulevard, Suite A  
Edinburg, Texas 78539

EMAIL: Anthony@GDJeng.com

Dear Mr. Garza:

Thank you for your request for Professional Services. The following information is presented to confirm our assignment and provide information that you may find helpful.

Our Project Number:

Project Name: 10th Street and Dicker Rd.- LoneStar

Assigned Project Manager: Kurt Schumacher, RPLS

Type Billing: Hourly Plus Project Direct Costs

Fee: Construction Staking \$ 1,600.00

Project Direct Costs: In addition, project direct costs including, but not limited to, travel and mileage, printing, photocopying, and survey fuel surcharge will be charged as incurred. All other project specific charges, consultant fees and other third party costs will be charged at cost plus ten percent (10%).

State, City and MTA Sales Tax (8.25%) will be charged on surveying fees, prints and reproductions when applicable, in accordance with State Law. The State Comptroller of Texas requires that taxes be charged on taxable services provided on contracts with non-exempt third parties, even if the services are being performed on behalf of a tax exempt entity/owner. The Client is responsible for any and all State sales taxes and associated costs and/or penalties that V&A may be required to pay by the State Comptroller's Office related to this project even if the appropriate sales taxes are not charged to the Client by V&A. Tax exempt certificates are required for work performed on behalf of a tax exempt entity.



*Rm*

Initial Here

**Error! Reference source not found. Error! Reference source not found.**

November 18, 2019

The fee estimate provided is in accordance with the Terms & Conditions set forth in Attachment I. Fees are subject to renegotiation if separate contract terms and conditions are required.

## SERVICES TO BE PERFORMED

### PROJECT AND PROPERTY DESCRIPTION

Consultant will perform on-call construction staking services on an hourly basis at various project sites in and around Hidalgo County, Texas.

### SERVICES TO BE PROVIDED

#### CONSTRUCTION STAKING

Client will provide not less than three (3) days' notice to Consultant prior to performing the requested individual services outlined herein. All staking requests shall be submitted by email to [kschumacher@vickreyinc.com](mailto:kschumacher@vickreyinc.com). The email shall include a description of the staking to be performed, including any specific Contractor instructions, the date the stakes are to be completed, and a date that the staking may begin. Construction stakes outlined below will be set one time. Re-staking will be billed, as a supplemental service, on an hourly basis. Client agrees to have areas to be staked clear of stockpiles, construction materials, vehicles and other obstructions to the survey team. Delays for obstructions will be billed on an Hourly Basis. Client also agrees to preserve all of Consultant's Primary Control Stakes. Re-establishment of any Primary Control Stakes destroyed by others will be billed to Client on an Hourly Basis. The staking will be provided for a horizontal location only. No vertical data or cut sheets other than as specifically stated herein will be provided. If the allotted visits are exceeded due to the construction timeline being unable to support the requested staking in full, any additional visits will be billed to Client on an Hourly Basis. All estimates assume an 8 hour work day.

### ASSUMPTIONS AND EXCLUDED SERVICES

- Boundary Surveying
- Topographic & Tree Surveying
- Easements
- Metes & Bounds Descriptions
- Geotechnical/Environmental Engineering
- TxDOT, FEMA or TCEQ Coordination

### ITEMS TO BE PERFORMED BY OR PROVIDED BY CLIENT

- Right-of-Entry Coordination

All listed services to be performed in accordance with the attached Standard Terms & Conditions.



*RM*

Initial Here

**Error! Reference source not found. Error! Reference source not found.**

November 18, 2019

You should review this information and advise our office of any corrections that are needed.

Please complete the following information and return one executed agreement by email within ten (10) days and one executed original within thirty (30) days. Receipt of properly executed agreement will constitute your authorization for V&A to commence work on these Professional Services. This agreement is void if not signed and returned within thirty (30) days.

Should you need further information, please do not hesitate to call. We look forward to your reply and authorization to proceed.

Sincerely yours,

VICKREY & ASSOCIATES, INC.

TBPE Registration #159 / TBPLS Registration #10004100



Kurt Schumacher  
Staff RPLS

KS/df



*RM*

Initial Here

**Error! Reference source not found. Error! Reference source not found.**

November 18, 2019

TO BE COMPLETED BY CLIENT: (Please Type or Print Below)

**CLIENT:**

*This agreement is between Vickrey & Associates, Inc. and CLIENT. The CLIENT is identified as follows and is to be completed by the CLIENT:*

Robert Macheska, P.E, GDJ Engineering, LLC 81-5308035 is the responsible party for  
(Printed Name of Company Representative) (Client Company Name) (Tax ID No.)

all fees incurred under this Agreement and I am authorized to sign this Agreement on GDJ Engineering, LLC's behalf.  
(Company's)

Address: 2805 Fountain Plaza Blvd, Suite A, Edinburg, Texas 78539

Email: Robert@GDJEng.com Phone: (956) 603-2025

CLIENT'S SIGNATURE  (ALSO INITIAL AT BOTTOM OF PAGE)

PRINTED NAME: Robert Macheska

TITLE: Executive Vice President/COO

DATE: 11/25/19

**AUTHORIZED CLIENT CONTACT:**

*If different from above, designate the person to act with authority on Client's behalf regarding all matters in the performance of this contract:*

Company Name: \_\_\_\_\_

Authorized Contact Name: \_\_\_\_\_

Address: \_\_\_\_\_

Email: \_\_\_\_\_ Phone: \_\_\_\_\_

AUTHORIZED PARTY'S SIGNATURE \_\_\_\_\_ DATE \_\_\_\_\_

PRINTED NAME: \_\_\_\_\_

TITLE: \_\_\_\_\_

**BILLING CONTACT:**

*All invoices to be issued in CLIENT COMPANY NAME as stated above; however, if the billing contact name or mailing address is different from the CLIENT information above, please provide a BILLING CONTACT NAME and c/o mailing address where invoices are to be sent.*

Billing Contact Name: Yvonne Leija

c/o Company Name: GDJ Engineering, LLC

Address: 2805 Fountain Plaza Blvd, Suite A, Edinburg, Texas 78539

Email: Yvonne@GDJEng.com Phone: (956) 603-2025

Terms and conditions of this Agreement are set forth in Attachment I attached hereto and made a part hereof. By execution of this agreement Client acknowledges that it has been informed and has read and fully understands and consents to them.

Period of Service: The compensation amount stipulated is conditioned on a period of service not exceeding **6** months for design and **12** months for construction OR **180** days. If such period of service is extended, the compensation amount for V&A's services shall be appropriately adjusted.



RM

Initial Here

VICKREY & ASSOCIATES, INC.
PROFESSIONAL SERVICE AGREEMENT
STANDARD TERMS & CONDITIONS
ATTACHMENT I

CONSULTANT SERVICES:

Vickrey & Associates, Inc. (V&A) is being engaged by CLIENT to render professional engineering or surveying services in connection with CLIENT's project.

V&A will perform its services in a professional manner in accordance with the standard of care and diligence normally practiced by recognized professional engineering firms...

V&A agrees to comply with all Federal, State and local laws and ordinances applicable to the services being provided hereunder on this project.

Many permitting agencies provide specified review time lines that are often not met by the review agencies. As a result, V&A makes no warranties as to time frames required or the ability to obtain permits or approvals.

CLIENT RESPONSIBILITY:

CLIENT shall provide V&A the following:

- a) CLIENT's criteria and requirements for the project;
b) Right-of-entry and access for V&A to enter upon the project site...
c) All information available to or known by CLIENT...
d) Timely examination and response to Engineer's submittals.

CHANGES IN SCOPE OF SERVICES:

If CLIENT makes changes to the scope of services shown in the Professional Services Agreement attached hereto, and/or if unknown or unforeseen conditions are encountered in the field...

In the event there are modifications and/or additions to Regulatory Requirements or agency review processes related to the services performed under this Agreement...

In the event work is ordered verbally by CLIENT or his representative or agent and/or if immediate services are required to respond to construction issues, permitting, or required design changes on behalf of CLIENT or the project...

GENERAL CONDITIONS:

- OWNERSHIP & REUSE OF DOCUMENTS
CERTIFICATIONS, GUARANTEES AND WARRANTIES
INSURANCE

parties, against claims for damages and to insure compliance of work performance and materials with Project requirements.

PLEASE CHOOSE OPTION A OR B:

\* OPTION A: LIMITATION OF LIABILITY CLAUSE:

In recognition of the relative risks, rewards and benefits of the Project to both CLIENT and the Firm, the risks have been allocated such that CLIENT agrees that, to the fullest extent permitted by law, the Firm's total liability to CLIENT for any and all injuries, claims, losses, expenses, damages or claim expenses arising out of this Agreement...

Option A (initial here) RM (Client) (V&A)

\* OPTION B: WAIVER OF LIMITATION OF LIABILITY:

In the event CLIENT is unwilling or unable to limit liability for any and all injuries, claims, losses, expenses, damages or claim expenses arising out of this Agreement to a maximum of the amount of compensation received by V&A for services performed under this Agreement...

Option B (initial here) (Client) (V&A)

CLIENT

By: Title

\* V&A shall not be held liable under any circumstances for damages or consequential damages for inadequate value, costs of repair, and/or replacement of an alleged defective installation or loss of profits without a claim for personal injury or damage to property.

\* ASSIGNMENT

CLIENT may not delegate, assign, sublet or transfer its duties or interest in this Agreement without the written consent of V&A.

\* TERMINATION

This Agreement may be terminated by either party on receipt of written notice or by mutual agreement. If this Agreement is terminated by either party, V&A shall be paid in full for all services performed through the termination date...

PAYMENT

CLIENT will pay V&A in accordance with Vickrey & Associates, Inc. current Fee Schedule and the Professional Service Agreement attached hereto.

Invoices will be submitted in our standard format on a monthly basis or at the completion of work.

Payments for services rendered are due and payable upon receipt of our invoice. Thereafter V&A reserves the right to include an amount up to the maximum allowed by law for interest charges.

If Invoices are not paid within 30 days of receipt, V&A may terminate performance of services without liability whatsoever to CLIENT.

Preparation of customized invoice formats will be charged on a time basis in accordance with V&A's current fees.

Vickrey & Associates, Inc. accepts MasterCard and Visa. A six percent (6%) fee will be added for any payment made by credit card.

APPLICABLE LAW

This Agreement shall be governed by the laws of the State of Texas, County of Bexar. Any complaints regarding surveying services may be forwarded to: Texas Board of Professional Land Surveying, Building A, Suite 156, 12100 Park 35 Circle, Austin, Texas 78753, (512) 239-5263.

RM

Initial Here



General Engineering Services / Transportation /  
 Environmental / Planning and Development /  
 Water Resources / Construction

## CONTRACT RATES

LABOR CLASSIFICATION	CONTRACT RATE
Senior Project Manager/Principal	\$ 225.00
Project Manager	\$ 195.00
Project Engineer	\$ 144.00
Utility Manager	\$ 141.00
Engineer-In-Training	\$ 95.00
Engineering Technician	\$ 82.00
Admin/Clerical	\$ 55.00
DIRECT EXPENSES	COST
Postage	At Cost
Black And White Copies	No Cost
Color Copies	\$0.50 per Page
Fax	No Cost
Overnight Mail - Letter Size	\$15.00 per Each
Overnight Mail - Oversized Box	\$38.00 per Each
Long Distance Charges	No Cost
Mileage	\$0.58 per Mile
Travel Expenses (Lodging)	\$90.00 per Night
Travel Expenses (Airfare)	At Cost
Scans To File	No Cost
Recording Fees	At Cost



# JACKSON, SJOBERG & TOWNSEND, LLP

711 West 7th Street  
 Austin, Texas 78701  
 (512) 472-7600  
 www.jacksonsjoberg.com

Lonestar Generation  
 c/o Kindle Energy LLC  
 500 Alexander Park, Suite 300  
 Princeton, New Jersey 08540

DEC 04 2019

Date	Invoice No.
11/20/2019	13370
Matter	
Lonestar Pipeline/TRRC/Frontera	

Date	Item	Description	Qty	Amount
10/28/2019	EAT	Dicker Road Improvements -- Review and exchange emails with Grace Kurdian regarding the accept date of a certificate of insurance to provide additional insured coverage; Review Supreme Court case dealing with certificates of insurance and the discovery rule.	1	475.00

TXDOT

PO# N/A Project# N/A Total Due \_\_\_\_\_  
 GL Acct# \_\_\_\_\_  
119100.01  
 Taxable? N Tax pd on Inv? N Tax Owed \_\_\_\_\_  
 Approved by: \_\_\_\_\_  
 Plant Manager

OK to pay  
 JSK

Tax ID No. 74-2900378

Total \$475.00



# Invoice

Date	Invoice #
11/8/2019	519107-1219

Millennium Engineers Group Inc  
 PO Box 4569, Edinburg, Texas  
 78540-4569

<b>Bill To</b>
Lonestar Pipeline Company, LLC William Lee Davis c/o Kindle Energy LLC 500 Alexander Drive, Suite 300 Princeton, NJ 08540

<b>Terms</b>	<b>Due Date</b>	<b>MEG Project</b>
Due on receipt	11/8/2019	Asbestos Sampling Services

Description	Qty	Rate	Amount
PROJ# 17MH033 PROJECT NAME: Asbestos Sampling Services Diker Rd. and 10th St. - Hidalgo, Hidalgo County, Texas MEG is prepared to provide the professional services necessary to conduct the Limited Asbestos Survey(s) of the areas of the Pipe, samplings, testing, analyzing, quantifying and provide a written report to included photos of the first positive sample collected of each individual homogeneous area. Project site will require a total of three (3) bulk samples. All work will be in accordance with the Asbestos Hazard Emergency Response Act (AHERA) 40 CFR 763, SUBPART E, the Texas Asbestos Health Protection Rules (TAHPR) dated February 2006 and EPA 40 CFR 61.145 Standard for Demolition, Renovation and The Environmental Protection Agency (EPA) National Emission Standards for Hazardous Air Pollutants (NESHAP).	1	1,500.00	1,500.00

Innovative. Experienced. Professional.	<b>Total</b>	\$1,500.00
--	--------------	------------

<b>Phone #</b>	<b>Fax #</b>
9567028500	(956) 702-4180

<b>Payments/Credits</b>	\$0.00
<b>Balance Due</b>	<b>\$1,500.00</b>

Make all checks payable to Millennium Engineers Group, Inc.  
 Any questions regarding this invoice please contact our Accounts Receivables Department at (956) 702-8500

TxDOT  
 Reimbursable



# Invoice

**Desert NDT, LLC**  
5875 N. Sam Houston Pkwy. West  
Suite 200  
Houston, TX 77086  
Ph: (580) 225-2108  
billing@desertndt.com

**Please Remit Payment To:**  
PO Box 733184  
Dallas, TX 75373-3184

**Bill To**  
Accounts Payable  
Lonestar Pipeline Company, LLC  
c/o Kindle Energy, LLC  
500 Alexander Park Drive, Suite 300  
Princeton NJ 08540

<b>Date</b>	11/14/2019
<b>Invoice #</b>	312854
<b>Terms</b>	Net 45
<b>Due Date</b>	12/29/2019
<b>Site Location</b>	Hidalgo, TX
<b>Lead Tech</b>	502125 Barrientos, Faustino
<b>Customer PO #</b>	17MH033
<b>Customer AFE #</b>	
<b>Well Name</b>	DICKER RD PROJECT
<b>Other Billing Info</b>	

Date	Ticket ID	Description	Quantity	Rate	Amount
11/12/2019	Ticket #PH484864	Mobile X-Ray Crew - R/T	8	110.00	880.00
		8" Weld Charge	14	9.50	133.00
		Mileage	20	1.35	27.00
		Safety Equipment	2	20.00	40.00
		Source Depletion Fee	1	40.00	40.00

**Total** **\$1,120.00**

TxDOT  
Reimbursable

**Radiographic Testing**



Order #: PH484864  
 Ticket No.: T-843-D92-1D92  
 Ticket Date: 11/12/19

<b>Bill To:</b>		<b>Job Info:</b>	
<input checked="" type="checkbox"/> <b>Customer:</b>	Lonestar Pipeline Company, LLC	<b>Work Type:</b>	New Construction
<input type="checkbox"/> <b>Contractor:</b>		<b>Location Type:</b>	Pipeline
<b>Address:</b>	c/o Kindle Energy, LLC	<b>Code:</b>	API 1104 20TH EDITION
<b>City, State, Zip:</b>	Princeton, NJ 08540	<b>Region Code:</b>	02 SOUTH TX
<b>Job Location:</b>	Hidalgo, TX	<b>Branch Location:</b>	22 Pharr
<b>Requestor Name:</b>	James N/A		
<b>Phone Number:</b>	(713) 201-6644		
<b>PO Number:</b>	17MH033		
<b>AFE:</b>			
<b>Well Name:</b>	DICKER RD PROJECT		
<b>Other Billing Requirements:</b>			
<b>Tech Notes:</b>			

X-RAY NO.	WS #	LOCATION	WITHIN CODE		WALL T	PIPE SIZE	NO. OF EXP.	IQI				SHIM THK	REMARKS
			YES	NO				WIRE SET & WIRE #	PENT #	SOURCE SIDE	FILM SIDE		
1	XR 1	LP/AC	0-A A-B B-0	<input checked="" type="checkbox"/>	<input type="checkbox"/>	0.322"	8" Weld	3	B7	<input type="checkbox"/>	<input checked="" type="checkbox"/>		
2	XR 2	LP/AC	0-A A-B B-0	<input checked="" type="checkbox"/>	<input type="checkbox"/>	0.322"	8" Weld	3	B7	<input type="checkbox"/>	<input checked="" type="checkbox"/>		
3	XR 3	LP/AC	0-A A-B B-0	<input checked="" type="checkbox"/>	<input type="checkbox"/>	0.322"	8" Weld	3	B7	<input type="checkbox"/>	<input checked="" type="checkbox"/>		
4	XR 4	LP/AC	0-A A-B B-0	<input checked="" type="checkbox"/>	<input type="checkbox"/>	0.322"	8" Weld	3	B7	<input type="checkbox"/>	<input checked="" type="checkbox"/>		
5	XR 5	LP/AC	0-A A-B B-0	<input checked="" type="checkbox"/>	<input type="checkbox"/>	0.322"	8" Weld	3	B7	<input type="checkbox"/>	<input checked="" type="checkbox"/>		
6	XR 6	LP/AC	0-A A-B B-0	<input checked="" type="checkbox"/>	<input type="checkbox"/>	0.322"	8" Weld	3	B7	<input type="checkbox"/>	<input checked="" type="checkbox"/>		
7	XR 7	LP/AC	0-A A-B B-0	<input checked="" type="checkbox"/>	<input type="checkbox"/>	0.322"	8" Weld	3	B7	<input type="checkbox"/>	<input checked="" type="checkbox"/>		
8	XR 8	LP/AC	0-A A-B B-0	<input checked="" type="checkbox"/>	<input type="checkbox"/>	0.322"	8" Weld	3	B7	<input type="checkbox"/>	<input checked="" type="checkbox"/>		
9	XR 9	LP/AC	0-A A-B B-0	<input checked="" type="checkbox"/>	<input type="checkbox"/>	0.322"	8" Weld	3	B7	<input type="checkbox"/>	<input checked="" type="checkbox"/>		
10	XR 10	LP/AC	0-A A-B B-0	<input checked="" type="checkbox"/>	<input type="checkbox"/>	0.322"	8" Weld	3	B7	<input type="checkbox"/>	<input checked="" type="checkbox"/>		
11	XR 11	LP/AC	0-A A-B B-0	<input checked="" type="checkbox"/>	<input type="checkbox"/>	0.322"	8" Weld	3	B7	<input type="checkbox"/>	<input checked="" type="checkbox"/>		
12	XR 12	LP/AC	0-A A-B B-0	<input checked="" type="checkbox"/>	<input type="checkbox"/>	0.322"	8" Weld	3	B7	<input type="checkbox"/>	<input checked="" type="checkbox"/>		
13	XR 13	LP/AC	0-A A-B B-0	<input checked="" type="checkbox"/>	<input type="checkbox"/>	0.322"	8" Weld	3	B7	<input type="checkbox"/>	<input checked="" type="checkbox"/>		
14	XR 14	LP/AC	0-A A-B B-0	<input checked="" type="checkbox"/>	<input type="checkbox"/>	0.322"	8" Weld	3	B7	<input type="checkbox"/>	<input checked="" type="checkbox"/>		

<b>ABBREVIATIONS</b>		<b>LOCATION</b>		<b>Total Hours:</b> 8	<b>Per Diem:</b> 0
I.P. INADEQUATE PENETRATION	S.P. SPHERICAL POROSITY	R.S. RIGHT OF WAY SIDE		<b>No. of Welds:</b> 14	<b>No. of Personnel:</b> 2
I.P.D. INADEQUATE PENETRATION DUE TO HIGH/LOW	C.P. CLUSTER POROSITY	D.S. DITCH SIDE		<b>Miles:</b> 20	
I.C. INTERNAL CONCAVITY	P.P. PIPING POROSITY	T. TOP		<b>Technician Name:</b> Faustino Barrientos	
I.F. INCOMPLETE FUSION	H.B. HOLLOW BEAD	B. BOTTOM		<b>Technician Level:</b> Tech Lead Level II	
I.F.C.L. INCOMPLETE FUSION DUE TO COLD LAP	C.R. CRACKS	T.Q. TOP QUARTER		<b>Technician Signature:</b>	
B.T. BURN THROUGH	A.D. ACCUMULATION OF DISCONTINUITIES	B.Q. BOTTOM QUARTER			
E.S.I. ELONGATED SLAG INCLUSION	I.U. INTERNAL UNDERCUT			<b>Assistant Technician:</b> Rusty Cabello	
I.S.I. ISOLATED SLAG INCLUSIONS	O.U. OUTSIDE UNDERCUT			<b>Assistant Technician Level:</b> Assistant Tech Level II	
	P.H. PINHOLE				

**NOTICE**

The above report and any consultation with the customer representative or contractor regarding the results of the inspection, represents the good faith opinion of the technician assigned to the project. Customer agrees with the results of the inspection and confirms that the personnel of Shawcor Inspection Services ("Shawcor") have performed their services in accordance with the customer's specifications of the relevant codes and standards and the scope of the inspection. Shawcor assumes no further responsibility for the radiographs and/or reports. Customer, by signature below, verifies time and material in whole and that the project location was not damaged by personnel or equipment and was left in satisfactory condition, unless otherwise noted. **SHAWCOR DISCLAIMS ALL WARRANTIES, EXPRESS OR IMPLIED, INCLUDING THOSE OF MERCHANTABILITY, FITNESS FOR ANY PARTICULAR PURPOSE AND WORKMANLIKE QUALITY AS TO ANY ITEM, MATERIAL OR PRODUCT PROVIDED, INSPECTED OR TESTED OR THE SERVICES PROVIDED IN CONNECTION WITH THE INSPECTION.** In no event shall Shawcor's liability, with respect to items inspected (including any liability pertaining to the scope of the inspection and/or the results of the inspection) exceed the charge of Shawcor for the inspection.

<b>Ticket No.:</b> T-843-D92-1D92	<b>Agreed and Accepted - (FULL SIGNATURE):</b> 	<b>Date:</b> 11/12/19	<b>Printed Name:</b> James Longhorn	<b>Phone No.:</b>
--------------------------------------	--	--------------------------	--	-------------------



# Invoice

**Desert NDT, LLC**

5875 N. Sam Houston Pkwy. West  
 Suite 200  
 Houston, TX 77086  
 Ph: (580) 225-2108  
 billing@desertndt.com

**Please Remit Payment To:**  
 PO Box 733184  
 Dallas, TX 75373-3184

**Bill To**

Accounts Payable  
 Lonestar Pipeline Company, LLC  
 c/o Kindle Energy, LLC  
 500 Alexander Park Drive, Suite 300  
 Princeton NJ 08540

**Date** 11/26/2019  
**Invoice #** 313205  
  
**Terms** Net 45  
**Due Date** 1/10/2020  
**Site Location** McAllen, TX  
**Lead Tech** 501357 Proa Banda, Juan A  
**Customer PO #** 17MH033  
**Customer AFE #**  
  
**Well Name** Dicker rd Bore  
**Other Billing Info**

Date	Ticket ID	Description	Quantity	Rate	Amount
11/23/2019	Ticket #PH485028	Mobile X-Ray Crew - O/T	10	147.50	1,475.00
		8" Weld Charge	8	9.50	76.00
		Mileage	20	1.35	27.00
		Safety Equipment	2	20.00	40.00
		Source Depletion Fee	1	40.00	40.00
		Subtotal			
11/25/2019	Ticket #PH485039	Mobile X-Ray Crew - R/T	8	110.00	880.00
		8" Weld Charge	2	9.50	19.00
		Mileage	30	1.35	40.50
		Safety Equipment	2	20.00	40.00
		Source Depletion Fee	1	40.00	40.00
		Subtotal			

**Total** **\$2,677.50**

TxDOT  
 Reimbursable

<b>Bill To:</b>		<b>Job Info:</b>	
<input checked="" type="checkbox"/> <b>Customer:</b>	Lonestar Pipeline Company, LLC	<b>Work Type:</b>	New Construction
<input type="checkbox"/> <b>Contractor:</b>		<b>Location Type:</b>	Pipeline
<b>Address:</b>	c/o Kindle Energy, LLC	<b>Code:</b>	API 1104
<b>City, State, Zip:</b>	Princeton, NJ 08540	<b>Region Code:</b>	02 SOUTH TX
<b>Job Location:</b>	McAllen, TX	<b>Branch Location:</b>	22 Pharr
<b>Requestor Name:</b>	James Lonestar		
<b>Phone Number:</b>	(713) 201-6644		
<b>PO Number:</b>	17MH033		
<b>AFE:</b>			
<b>Well Name:</b>	Dicker Rd Bore		
<b>Other Billing Requirements:</b>			
<b>Tech Notes:</b>			

X-RAY NO.	WS #	LOCATION	WITHIN CODE		WALL T	PIPE SIZE	NO. OF EXP.	IQI				SHIM THK	REMARKS
			YES	NO				WIRE SET & WIRE #	PENT #	SOURCE SIDE	FILM SIDE		
1	FB-1	IP	0-A,A-B,B-0	<input checked="" type="checkbox"/>	<input type="checkbox"/>	0.250"	8" Weld	3	B6	<input type="checkbox"/>	<input checked="" type="checkbox"/>		North Side
2	FB-2	IP/AC	0-A,A-B,B-0	<input checked="" type="checkbox"/>	<input type="checkbox"/>	0.250"	8" Weld	3	B6	<input type="checkbox"/>	<input checked="" type="checkbox"/>		North Side
3	FB-3	AC	0-A,A-B,B-0	<input checked="" type="checkbox"/>	<input type="checkbox"/>	0.250"	8" Weld	3	B6	<input type="checkbox"/>	<input checked="" type="checkbox"/>		North Side
4	FB-4	AC	0-A,A-B,B-0	<input checked="" type="checkbox"/>	<input type="checkbox"/>	0.250"	8" Weld	3	B6	<input type="checkbox"/>	<input checked="" type="checkbox"/>		South Side
5	FB-5	AC/IP	0-A,A-B,B-0	<input checked="" type="checkbox"/>	<input type="checkbox"/>	0.250"	8" Weld	3	B6	<input type="checkbox"/>	<input checked="" type="checkbox"/>		South Side
6	FB-6	IP	0-A,A-B,B-0	<input checked="" type="checkbox"/>	<input type="checkbox"/>	0.250"	8" Weld	3	B6	<input type="checkbox"/>	<input checked="" type="checkbox"/>		South Side
7	TI-1	IP/AC	0-A,A-B,B-0	<input checked="" type="checkbox"/>	<input type="checkbox"/>	0.250"	8" Weld	3	B6	<input type="checkbox"/>	<input checked="" type="checkbox"/>		North Side
8	TI-2	IP/AC	0-A,A-B,B-0	<input checked="" type="checkbox"/>	<input type="checkbox"/>	0.250"	8" Weld	3	B6	<input type="checkbox"/>	<input checked="" type="checkbox"/>		South Side

<b>ABBREVIATIONS</b>		<b>LOCATION</b>		<b>Total Hours:</b> 10	<b>Per Diem:</b> 0
I.P. INADEQUATE PENETRATION	S.P. SPHERICAL POROSITY	R.S. RIGHT OF WAY SIDE		<b>No. of Welds:</b> 8	<b>No. of Personnel:</b> 2
I.P.D. INADEQUATE PENETRATION DUE TO HIGH-LOW	C.P. CLUSTER POROSITY	D.S. DITCH SIDE		<b>Miles:</b> 20	
I.C. INTERNAL CONCAVITY	P.P. PIPING POROSITY	T. TOP		<b>Technician Name:</b> Juan Proa Banda	
I.F. INCOMPLETE FUSION	H.B. HOLLOW BEAD	B. BOTTOM		<b>Technician Level:</b> Tech Trainer Lead Level II	
I.F.C.L. INCOMPLETE FUSION DUE TO COLD LAP	C.R. CRACKS	T.Q. TOP QUARTER		<b>Technician Signature:</b>	
B.T. BURN THROUGH	A.D. ACCUMULATION OF DISCONTINUITIES	B.Q. BOTTOM QUARTER		<b>Assistant Technician:</b> Christian Acosta	
E.S.J. ELONGATED SLAG INCLUSION	I.U. INTERNAL UNDERCUT			<b>Assistant Technician Level:</b> Assistant Technician	
I.S.J. ISOLATED SLAG INCLUSIONS	O.U. OUTSIDE UNDERCUT				
	P.H. PINHOLE				

**NOTICE**

The above report and any consultation with the customer representative or contractor regarding the results of the inspection, represents the good faith opinion of the technician assigned to the project. Customer agrees with the results of the inspection and confirms that the personnel of Shawcor Inspection Services ("Shawcor") have performed their services in accordance with the customer's specifications of the relevant codes and standards and the scope of the inspection. Shawcor assumes no further responsibility for the radiographs and/or reports. Customer, by signature below, verifies time and material in whole and that the project location was not damaged by personnel or equipment and was left in satisfactory condition, unless otherwise noted. SHAWCOR DISCLAIMS ALL WARRANTIES, EXPRESS OR IMPLIED, INCLUDING THOSE OF MERCHANTABILITY, FITNESS FOR ANY PARTICULAR PURPOSE AND WORKMANLIKE QUALITY AS TO ANY ITEM, MATERIAL OR PRODUCT PROVIDED, INSPECTED OR TESTED OR THE SERVICES PROVIDED IN CONNECTION WITH THE INSPECTION. In no event shall Shawcor's liability, with respect to items inspected (including any liability pertaining to the scope of the inspection and/or the results of the inspection) exceed the charge of Shawcor for the inspection.

<b>Ticket No.:</b> T-934-84F-5E31	<b>Agreed and Accepted - (FULL SIGNATURE):</b> 	<b>Date:</b> 11/23/19	<b>Printed Name:</b> James Lonestar	<b>Phone No.:</b>
--------------------------------------	--	--------------------------	--	-------------------

<b>Bill To:</b>		<b>Job Info:</b>	
<input checked="" type="checkbox"/> <b>Customer:</b>	Lonestar Pipeline Company, LLC	<b>Work Type:</b>	New Construction
<input type="checkbox"/> <b>Contractor:</b>		<b>Location Type:</b>	Pipeline
<b>Address:</b>	c/o Kindle Energy, LLC	<b>Code:</b>	API 1104
<b>City, State, Zip:</b>	Princeton, NJ 08540	<b>Region Code:</b>	02 SOUTH TX
<b>Job Location:</b>	McAllen, TX	<b>Branch Location:</b>	22 Pharr
<b>Requestor Name:</b>	James Lonestar		
<b>Phone Number:</b>	(713) 201-6644		
<b>PO Number:</b>	17MH033		
<b>AFE:</b>			
<b>Well Name:</b>	Dicker Rd Bore		
<b>Other Billing Requirements:</b>			
<b>Tech Notes:</b>			

X-RAY NO.	WS #	LOCATION	WITHIN CODE		WALL T	PIPE SIZE	NO. OF EXP.	IQI				SHIM THK	REMARKS
			YES	NO				WIRE SET & WIRE #	PENT #	SOURCE SIDE	FILM SIDE		
1	TH-3	IP	0-A,A-B,B-0	<input checked="" type="checkbox"/>	<input type="checkbox"/>	0.250"	8" Weld	3	B6		<input type="checkbox"/>	<input checked="" type="checkbox"/>	
2	TH-4	IP	0-A,A-B,B-0	<input checked="" type="checkbox"/>	<input type="checkbox"/>	0.250"	8" Weld	3	B6		<input type="checkbox"/>	<input checked="" type="checkbox"/>	

<b>ABBREVIATIONS</b>		<b>LOCATION</b>		<b>Total Hours:</b> 8	<b>Per Diem:</b> 0
I.P. INADEQUATE PENETRATION	S.P. SPHERICAL POROSITY	R.S. RIGHT OF WAY SIDE		<b>No. of Welds:</b> 2	<b>No. of Personnel:</b> 2
I.P.D. INADEQUATE PENETRATION DUE TO HIGH-LOW	C.P. CLUSTER POROSITY	D.S. DITCH SIDE		<b>Miles:</b> 30	
I.C. INTERNAL CONCAVITY	P.P. PIPING POROSITY	T. TOP		<b>Technician Name:</b> Juan Proa Banda	
I.F. INCOMPLETE FUSION	H.B. HOLLOW BEAD	B. BOTTOM		<b>Technician Level:</b> Tech Trainer Lead Level II	
I.F.C.L. INCOMPLETE FUSION DUE TO COLD LAP	C.R. CRACKS	T.Q. TOP QUARTER		<b>Technician Signature:</b> 	
B.T. BURN THROUGH	A.D. ACCUMULATION OF DISCONTINUITIES	B.Q. BOTTOM QUARTER		<b>Assistant Technician:</b> Christian Acosta	
E.S.I. ELONGATED SLAG INCLUSION	I.U. INTERNAL UNDERCUT			<b>Assistant Technician Level:</b> Assistant Technician	
I.S.I. ISOLATED SLAG INCLUSIONS	O.U. OUTSIDE UNDERCUT				
	P.H. PINHOLE				

**NOTICE**

The above report and any consultation with the customer representative or contractor regarding the results of the inspection, represents the good faith opinion of the technician assigned to the project. Customer agrees with the results of the inspection and confirms that the personnel of Shawcor Inspection Services ("Shawcor") have performed their services in accordance with the customer's specifications of the relevant codes and standards and the scope of the inspection. Shawcor assumes no further responsibility for the radiographs and/or reports. Customer, by signature below, verifies time and material in whole and that the project location was not damaged by personnel or equipment and was left in satisfactory condition, unless otherwise noted. SHAWCOR DISCLAIMS ALL WARRANTIES, EXPRESS OR IMPLIED, INCLUDING THOSE OF MERCHANTABILITY, FITNESS FOR ANY PARTICULAR PURPOSE AND WORKMANLIKE QUALITY AS TO ANY ITEM, MATERIAL OR PRODUCT PROVIDED, INSPECTED OR TESTED OR THE SERVICES PROVIDED IN CONNECTION WITH THE INSPECTION. In no event shall Shawcor's liability, with respect to items inspected (including any liability pertaining to the scope of the inspection and/or the results of the inspection) exceed the charge of Shawcor for the inspection.

<b>Ticket No.:</b>	<b>Agreed and Accepted - (FULL SIGNATURE):</b>	<b>Date:</b>	<b>Printed Name:</b>	<b>Phone No.:</b>
T-2CA-46C-A471		11/25/19	James Lonestar	

C4 Vacuum & Oilfield Service, LLC

3609 Goldcrest Ave  
 McAllen, TX 78504  
 (956) 212-6840  
 c4.lana@gmail.com

# Invoice

Date	Invoice #
12/3/19	2344

<b>Bill To</b>
Lone Star Pipeline Company c/o Kindle Energy LLC 500 Alexander Park Drive, Suite 300 Princeton, NJ 08540

<b>Remit To</b>
C4 Vacuum & Oilfield Service, LLC 3609 Goldcrest Ave McAllen, TX 78504 (Or by wiring Instructions)

Ordered By:		Project Ref Code	Terms	Due Date	Project Reference	
James		17MH033	Due on receipt	12/3/19	Dicker Road Pipeline Install	
Date	Item	Driver Ticket No. / Description		Qty / Hrs	Rate	Amount
11/13/19	Vacuum Truck Disposal Fee	CR9042		6 50	79.00 0.50	474.00 25.00
11/14/19	Vacuum Truck Disposal Fee	CR9043		6 50	79.00 0.50	474.00 25.00
11/15/19	Vacuum Truck	CR9044		10.5	79.00	829.50
11/16/19	Vacuum Truck Wash Out	CR9045		11 1	79.00 300.00	869.00 300.00
11/23/19	Vacuum Truck Disposal Fee	CR9046		7 60	79.00 0.50	553.00 30.00
11/25/19	Vacuum Truck Disposal Fee	CR9047		6 60	79.00 0.50	474.00 30.00
				<b>Sub-Total</b>		\$4,083.50
				<b>Tax</b>		\$0.00
				<b>Total</b>		<b>\$4,083.50</b>

# FIELD TICKET

Date: 11/13/19  
Mon Tues Wed Thu Fri Sat Sun



Company: Love Star Pipeline  
Service Ordered By: James

**Vacuum & Oilfield  
Service, LLC.**

Service Rendered: Hauled 50 BBLs of Freshwater to  
Fill pipeline

Location / Lease: Dicker Rd. End Destination: Pipeline Install

Well #: Hidalgo, TX

Start Time: \_\_\_\_\_ AM / PM End Time: \_\_\_\_\_ AM / PM

Truck Driver: \_\_\_\_\_ Truck Number: \_\_\_\_\_ Total Truck Hours: \_\_\_\_\_

<u>6</u> Hours @ <u>79</u> Per Hour	<u>1474<sup>00</sup></u> (Vac TK / Winch Tk / Lease Work)
_____ Hours @ _____ Per Hour	_____ (Stand By Time - Vacuum Trucks)
_____ Hands @ _____ Per Hand	_____ (Swamper / Foreman / Hands)
<u>50</u> Barrels @ <u>.50<sup>00</sup></u> Per Barrel	<u>25<sup>00</sup></u> (Disposal Fee / Fresh Water / KCL)
_____ Barrels @ _____ Per Barrel	_____ (Bid by Bbl.) (OBM) (WBM)
_____ Loads @ _____ Per Load	_____ (Bid by Load)
_____ Sacks @ _____ Per Sack	_____ (KCL, Etc.)

Notes: \_\_\_\_\_  
((STAMP AREA))

Sub Total: \$ 499<sup>00</sup>

Fuel Surcharge: \_\_\_\_\_

Tax: \_\_\_\_\_

Grand Total: 3499<sup>00</sup>

Approved By / Company Representative: \_\_\_\_\_

CR9043

# FIELD TICKET

Date: 11/14/19 ~~2018~~  
Mon Tues Wed Thu Fri Sat Sun



Company: Lone Star Pipeline

**Vacuum & Oilfield  
Service, LLC.**

Service Ordered By: James

Service Rendered: Emptied pipeline and haul water to  
Disposal

Location / Lease: Dicker Rd.

End Destination: Pipeline Instal

Well #: Hidalgo, TX.

Start Time: \_\_\_\_\_ AM / PM

End Time: \_\_\_\_\_ AM / PM

Truck Driver: F. Camargo Truck Number: \_\_\_\_\_ Total Truck Hours: \_\_\_\_\_

6 hrs. Hours @ 79 Per Hour 474<sup>00</sup> (Vac TK / Winch Tk / Lease Work)

\_\_\_\_\_ Hours @ \_\_\_\_\_ Per Hour \_\_\_\_\_ (Stand By Time - Vacuum Trucks)

\_\_\_\_\_ Hands @ \_\_\_\_\_ Per Hand \_\_\_\_\_ (Swamper / Foreman / Hands)

50 Barrels @ 50 Per Barrel 25<sup>00</sup> (Disposal Fee / Fresh Water / KCL)

\_\_\_\_\_ Barrels @ \_\_\_\_\_ Per Barrel \_\_\_\_\_ (Bid by Bbl.) (OBM) (WBM)

\_\_\_\_\_ Loads @ \_\_\_\_\_ Per Load \_\_\_\_\_ (Bid by Load)

\_\_\_\_\_ Sacks @ \_\_\_\_\_ Per Sack \_\_\_\_\_ (KCL, Etc.)

Notes: \_\_\_\_\_  
((STAMP AREA))

Sub Total: \$499<sup>00</sup>

Fuel Surcharge: \_\_\_\_\_

Tax: \_\_\_\_\_

Grand Total: \$499<sup>00</sup>

Approved By / Company Representative: \_\_\_\_\_

OFFICE: 956-212-6840 DISPATCH: (956) 322-0790 E-MAIL: c4.lana@gmail.com  
MAILING ADDRESS: 3609 Goldcrest Ave, McAllen, TX 78504

CR 9044

# FIELD TICKET

Date: 11/15/19  
Mon Tues Wed Thu Fri Sat Sun



Company: Lonestar Pipeline  
Service Ordered By: Scmes

**Vacuum & Oilfield  
Service, LLC.**

Service Rendered: Worked on location while boring hole  
and pick up drill cuttings.

Location / Lease: Dicker Rd End Destination: ~~CLARK ST~~

Well #: Hidalgo, K. ~~W~~ Pipeline Install

Start Time: \_\_\_\_\_ AM / PM End Time: \_\_\_\_\_ AM / PM

Truck Driver: F. Cumargo Truck Number: 234 Total Truck Hours: \_\_\_\_\_

<u>10.5</u> Hours @ <u>829<sup>50</sup></u> Per Hour	_____	(Vac TK / Winch Tk / Lease Work)
_____ Hours @ _____ Per Hour	_____	(Stand By Time - Vacuum Trucks)
_____ Hands @ _____ Per Hand	_____	(Swamper / Foreman / Hands)
_____ Barrels @ _____ Per Barrel	_____	(Disposal Fee / Fresh Water / KCL)
_____ Barrels @ _____ Per Barrel	_____	(Bid by Bbl.) (OBM) (WBM)
_____ Loads @ _____ Per Load	_____	(Bid by Load)
_____ Sacks @ _____ Per Sack	_____	(KCL, Etc.)

Notes: \_\_\_\_\_  
((STAMP AREA))

Sub Total: 829<sup>50</sup>

Fuel Surcharge: \_\_\_\_\_

Tax: \_\_\_\_\_

Grand Total: 829<sup>50</sup>

Approved By / Company Representative: \_\_\_\_\_

OFFICE: 956-212-6840 DISPATCH: (956) 322-0790 E-MAIL: c4.lana@gmail.com  
MAILING ADDRESS: 3609 Goldcrest Ave, McAllen, TX 78504

CR9045

# FIELD TICKET

Date: 11/16/19  
Mon Tues Wed Thu Fri Sat Sun



Company: Lonestar Pipeline  
Service Ordered By: James

**Vacuum & Oilfield  
Service, LLC.**

Service Rendered: Worked on location while still boring hole and need to unload waste and washout

Location / Lease: Dicker Rd. End Destination: Pipeline  
Well #: Hidalgo, TX. Install

Start Time: \_\_\_\_\_ AM / PM End Time: \_\_\_\_\_ AM / PM

Truck Driver: F. Currao Truck Number: 234 Total Truck Hours: \_\_\_\_\_

<u>11</u> Hours @ <u>79<sup>00</sup></u> Per Hour	<u>869<sup>00</sup></u>	(Vac TK / Winch Tk / Lease Work)
_____ Hours @ _____ Per Hour	_____	(Stand By Time - Vacuum Trucks)
_____ Hands @ _____ Per Hand	_____	(Swamper / Foreman / Hands)
_____ Barrels @ _____ Per Barrel	_____	(Disposal Fee / Fresh Water / KCL)
_____ Barrels @ _____ Per Barrel	_____	(Bid by Bbl.) (OBM) (WBM)
_____ Loads @ _____ Per Load	_____	(Bid by Load)
_____ Sacks @ _____ Per Sack	_____	(KCL, Etc.)

Notes: \*300<sup>00</sup> for Washout  
((STAMP AREA))

Sub Total: \$1,169  
 Fuel Surcharge: \_\_\_\_\_  
 Tax: \_\_\_\_\_  
 Grand Total: \$1,169

Approved By / Company Representative: \_\_\_\_\_

OFFICE: 956-212-6840 DISPATCH: (956) 322-0790 E-MAIL: c4.lana@gmail.com  
MAILING ADDRESS: 3609 Goldcrest Ave, McAllen, TX 78504

CR 9046

# FIELD TICKET

Date: 11/23/19, 2018  
Mon Tues Wed Thu Fri Sat Sun



**Vacuum & Oilfield  
Service, LLC.**

Company: Lonestar Pipeline  
Service Ordered By: \_\_\_\_\_

Service Rendered: Hauled 60 BBLs of Freshwater to Fill  
Line

Location / Lease: Dicker Rd. End Destination: Pipeline  
Well #: Hidalgo, K. Install

Start Time: \_\_\_\_\_ AM / PM End Time: \_\_\_\_\_ AM / PM  
Truck Driver: F. Camargo Truck Number: 234 Total Truck Hours: \_\_\_\_\_

<u>7</u> Hours @ <u>79<sup>00</sup></u> Per Hour	<u>553<sup>00</sup></u>	(Vac TK / Winch Tk / Lease Work)
_____ Hours @ _____ Per Hour	_____	(Stand By Time - Vacuum Trucks)
_____ Hands @ _____ Per Hand	_____	(Swamper / Foreman / Hands)
<u>60</u> Barrels @ <u>50</u> Per Barrel	<u>30<sup>00</sup></u>	(Disposal Fee / Fresh Water / KCL)
_____ Barrels @ _____ Per Barrel	_____	(Bid by Bbl.) (OBM) (WBM)
_____ Loads @ _____ Per Load	_____	(Bid by Load)
_____ Sacks @ _____ Per Sack	_____	(KCL, Etc.)

Notes: \_\_\_\_\_  
((STAMP AREA))

Sub Total: 583<sup>00</sup>

Fuel Surcharge: \_\_\_\_\_

Tax: \_\_\_\_\_

Grand Total: 7583<sup>00</sup>

Approved By / Company Representative: \_\_\_\_\_

OFFICE: 956-212-6840 DISPATCH: (956) 322-0790 E-MAIL: c4.lana@gmail.com  
MAILING ADDRESS: 3609 Goldcrest Ave, McAllen, TX 78504

CR 9047

# FIELD TICKET

Date: 11/25/19  
Mon Tues Wed Thu Fri Sat Sun



Company: Lonestar Pipeline  
Service Ordered By: \_\_\_\_\_

**Vacuum & Oilfield  
Service, LLC.**

Service Rendered: Emptied pipeline and Hauled water  
to Disposal

Location / Lease: Dicker Rd. End Destination: Pipeline  
Well #: Hidalgo, TX. Install

Start Time: \_\_\_\_\_ AM / PM End Time: \_\_\_\_\_ AM / PM

Truck Driver: F. Camargo Truck Number: 234 Total Truck Hours: \_\_\_\_\_

<u>6</u> Hours @ <u>474</u> Per Hour	<u>474</u>	(Vac TK / Winch Tk / Lease Work)
_____ Hours @ _____ Per Hour	_____	(Stand By Time - Vacuum Trucks)
_____ Hands @ _____ Per Hand	_____	( Swamper / Foreman / Hands)
<u>60</u> Barrels @ <u>.50</u> Per Barrel	<u>30</u>	(Disposal Fee / Fresh Water / KCL)
_____ Barrels @ _____ Per Barrel	_____	(Bid by Bbl.) (OBM) (WBM)
_____ Loads @ _____ Per Load	_____	(Bid by Load)
_____ Sacks @ _____ Per Sack	_____	(KCL, Etc.)

Notes: \_\_\_\_\_  
((STAMP AREA))

Sub Total: \$504<sup>00</sup>

Fuel Surcharge: \_\_\_\_\_

Tax: \_\_\_\_\_

Grand Total: \$504<sup>00</sup>

Approved By / Company Representative: \_\_\_\_\_

OFFICE: 956-212-6840 DISPATCH: (956) 322-0790 E-MAIL: c4.lana@gmail.com  
MAILING ADDRESS: 3609 Goldcrest Ave, McAllen, TX 78504



**OMNI**  
**AIR & NITROGEN**

8809 E Hwy 80 • Midland, TX 79706  
432-288-9087 • www.omniairnitrogen.com

## INVOICE

**BILL TO**

Lonestar Pipeline Company, LLC  
c/o KindleEnergy LLC  
500 Alexander Park Drive, Suite 300  
Princeton, NJ 08540

**INVOICE #** 3636L**DATE** 12/20/2019**DUE DATE** 01/19/2020**TERMS** Net 30

---

<b>PROJECT NAME</b>	<b>COUNTY</b>	<b>CO. REP.</b>
17MH033-Dicker Road Pipeline In	Hidalgo, TX	Oscar Diaz

QUANTITY	DESCRIPTION	RATE	AMOUNT
1	12 hour operating day for 650 scfm / 500 psi N2 package	4,000.00	4,000.00
208	Gallons of diesel fuel for reimbursement	3.30	686.40
1	Accommodations and subsistence	250.00	250.00
15	Omni Trucking	130.00	1,950.00

---

**PO Number: 17MH033****BALANCE DUE****\$6,886.40**

TxDOT  
Reimbursable

We appreciate your business!

Invoices not paid within 30 days incur interest at 1 1/2% per month.

Date: 12/17/2019  
 Company: M&H Pipeline  
 Co. Rep: Oscar Diaz  
 Lease: 369 VALT VALVE  
 Well: \_\_\_\_\_  
 County: Hidalgo  
 Operator: Jason.F  
 Code: PO# 17MH033  
 AFE: \_\_\_\_\_  
 Rig: \_\_\_\_\_

## Daily Report

Time	PSI	SCFM	F/CI	Foam	C. Inh	Purity	Event Log
0:00							
1:00							
2:00							
3:00							
4:00							
5:00							
6:00							6:45 @ Location,6:45-7:28 SPOT/RIGUP UNIT
7:00							7:55-8:07 WARMUP
8:00	10	660				95%	8:02-2:14 N2 ONLINE PURGING
9:00	10	640				95%	N2 OL PURGING
10:00	10	590				95%	N2 OL PURGING
11:00	10	593				95%	N2 OL PURGING
12:00	24	525				95%	N2 OL PURGING
1:00	31	530				95%	N2 OL PURGING 12:10 SHUT IN PRESSURE UP TO 40 PSI
2:00	41	550				95%	2:14 @ PRESSURE 2:14-220 CD RIGDOWN
3:00							3:00 LEAVE LOCATION
4:00							
5:00							
6:00							
7:00							
8:00							
9:00							
10:00							
11:00							

Quantity	Description	Amount
	12hr Ready to Assist	\$0.00
1	12hr Operating Day	\$4,000.00
0	Gals. F/CI	\$0.00
0	Gals. Foamer	\$0.00
0	Gals. C. Inhibitor	\$0.00
208	Gals. Diesel	\$686.40
	BIW Stripper Head	\$0.00
	BIW Stripper Rubber	\$0.00
	Float w/ Insert	\$0.00
	Light Tower	\$0.00
	Extra Labor	\$0.00
15	Trucking	\$1,950.00
1	Per Diem	\$250.00
	<b>Total Daily Cost</b>	<b>\$6,886.40</b>
	<b>Accumulated Cost</b>	<b>\$6,886.40</b>

*Deven Wylie*