

THE STATE OF TEXAS §  
COUNTY OF HIDALGO §

**CONSTRUCTION CONTRACT  
C-19-267-06-02**

This Agreement entered into this 2nd day of June 2020, by and between the County of Hidalgo (hereinafter called the "OWNER") and Celso Gonzalez Construction, INC. (a corporation) (a partnership) (an individual) of Mission, State of Texas, hereinafter Called "CONTRACTOR". The County's procurement packet and Contractor's response are incorporated herein for all purposes.

**WITNESSETH**

That for and in consideration of the payments and agreement hereinafter mentioned, to be made and performed by the OWNER, the CONTRACTOR hereby agrees with the OWNER to commence and complete the construction described as follows:

**NAME OF PROJECT**

Hereinafter called the project, for the sum of (\$205,000.00) Two hundred Five Thousand Dollars and Zero Cents and all extra work in connection therewith, under the terms and stated in the General and Special Conditions of the Contract; and at his (its or their) own proper cost and expense to furnish all the materials, supplies, machinery, equipment, tools, superintendence, labor, insurance, and other accessories and services necessary to complete the said project in accordance with the conditions and prices stated in the Proposal, the General Conditions and Special Conditions printed or written explanatory matter thereof, the specifications and contract documents therefore as prepared by Half Associates, Inc., entitled the Architect/Engineer, and as enumerated in Paragraph 1.01.A.12 of the General Conditions, all of which are made a part hereof and collectively evidence and constitute the contract.

The CONTRACTOR hereby agrees to commence work under this contract on or after a date to be specified in written "Notice to Proceed" of the OWNER and to fully complete the project within 150 consecutive calendar days thereafter. The CONTRACTOR further agrees to pay, as liquidated damages, the sum of \$ 250 for each consecutive calendar day thereafter.

The OWNER agrees to pay the CONTRACTOR in current funds for the performance of the contract, subject to additions and deductions, as provided in the General Conditions of the contract, and to make payments on account thereof as provided in Paragraphs 14.02.C and 14.07.C of the General Conditions.

WITNESS THE HANDS OF THE PARTIES effective as of the day and year first written above.

APPROVED BY COMMISSIONERS COURT ON, June, 3rd, 2020

CONTRACTOR:  
Print Name & Title: Celso Gonzalez Jr. President  
Name of Firm: Celso Gonzalez Construction Inc.  
Address: 664 N. Conway  
Mission, TX 78572  
Fed I.D. #/SS #: 74-2531378

STATE OF TEXAS  
COUNTY OF HIDALGO

This instrument was acknowledged before me on this the 3rd day of June, 2020, by President Of and on behalf of Celso Gonzalez Construction Inc.  
(Title) (A corporation)

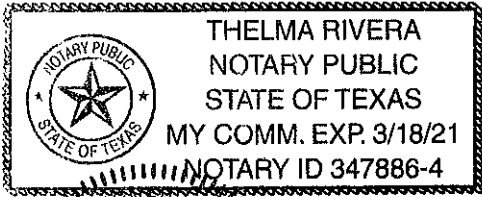

[Signature]  
Notary Public-Signature

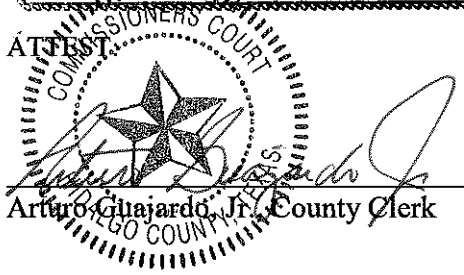

COUNTY OF HIDALGO:  
[Signature]  
Richard F. Cortez, County Judge

APPROVED AS TO FORM:  
Hidalgo County District Attorney's Office

APPROVED BY  
COMMISSIONERS COURT  
ON: 6/2/20 mg

By: [Signature]  
Robert Viña III, Assistant District Attorney



# PHILADELPHIA INSURANCE COMPANIES

A Member of the Tokio Marine Group

*Premium Based on Final Contact Price, Not Penal Sum*

Bond Number: PB11509801722

Initial Premium: \$4,075.00

## PERFORMANCE BOND

Take notice that CELSO GONZALEZ CONSTRUCTION, INC., 614 North Conway, Mission, TX 78572, as Principal (hereinafter called "the Principal"), and PHILADELPHIA INDEMNITY INSURANCE COMPANY, One Bala Plaza, Suite 100, Bala Cynwyd, Pennsylvania 19004, as Surety (hereinafter called "the Surety"), are held and firmly bound unto Hidalgo County Purchasing Department, 2802 South Business Highway 281, Edinburg, TX 78539, as Obligee, (hereinafter called "the Obligee"), in the amount of TWO HUNDRED FIVE THOUSAND AND 00/100 DOLLARS (\$205,000.00) (hereinafter called "the Penal Sum"), for the payment whereof the Principal and the Surety bind themselves, their heirs, executors, administrators, successors and assigns, jointly and severally, firmly by these presents.

WHEREAS, the Principal has by written agreement dated 1/1, entered into a contract with Obligee for RFB No : 2019-267-04-15-ABV - Construction of Bus Barn for Hidalgo County Sheriff's Office (hereinafter called "the Contract").

NOW THEREFORE, THE CONDITION OF THIS OBLIGATION is such that, if the Principal shall promptly and faithfully furnish all labor, material, and equipment necessary to complete the Principal's scope of work under the Contract (hereinafter collectively called "the Construction Work"), then this obligation shall be null and void, otherwise it shall remain in full force and effect subject to the terms and conditions of this Performance Bond.

1. The Surety's obligations under this Performance Bond are expressly conditioned upon:
  - a. The Obligee's compliance with the material terms of the Contract including, but not limited to, payment to the Principal as required by the Contract; and
  - b. The Obligee's written notice to the Principal and the Surety that it is considering declaring a Contractor Default. Within 5 business days of the Surety's receipt of the written notice described in this Paragraph 1(b), the Surety, in its sole discretion, may request a conference among the Obligee, the Principal and the Surety to discuss the Principal's completion of the Construction Work, which conference shall be conducted within 10 business days of the Surety's request for said conference; and
  - c. The Obligee's written notice to the Principal and the Surety of the Obligee's formal declaration of a Contractor Default and the termination of the Principal's right to complete the Construction Work, which formal declaration and termination shall not be made until 10 business days from the date of the Surety's receipt of the written notice required by Paragraph 1(b) or the date the conference described in Paragraph 1(b) of this Performance Bond occurs, whichever date last occurs; and
  - d. The Obligee's written notice to the Principal and the Surety of the Obligee's agreement to pay the Contract Balance to the Surety (or at the Surety's direction to a contractor selected by the Surety to perform the Construction Work as set forth herein).
2. If there is no Obligee Default and when all of the conditions precedent set forth in Paragraph 1 of this Performance Bond have been satisfied, the Surety shall, within 21 business days, provide written notice to the Obligee of the Surety's election of one of the following options:
  - a. Directing the Principal to complete the Construction Work with the Obligee's consent, which consent will not be unreasonably withheld; or



# PHILADELPHIA INSURANCE COMPANIES

A Member of the Tokio Marine Group

## 7. Definitions:

- a. **Contract Balance:** The total amount payable by the Obligee to the Principal under the Contract after all proper adjustments are made, including any amounts received or to be received by the Obligee in settlement of insurance or other claims for damages to which the Principal is entitled, reduced by all valid and proper payments made to or on behalf of the Principal under the Contract.
- b. **Contractor Default:** The failure of the Principal, which has not been remedied or waived, to perform or otherwise comply with a material term of the Contract relative to the Construction Work.
- c. **Obligee Default:** The failure of the Obligee, which has not been remedied or waived, to comply with a material term of the Contract relative to the Construction Work.

DATED:

  
CELSE GONZALEZ CONSTRUCTION, INC.  
(Principal)

By: \_\_\_\_\_

Philadelphia Indemnity Insurance Company  
(Surety)

By: 

Fred A. Thetford, IV, Attorney In Fact

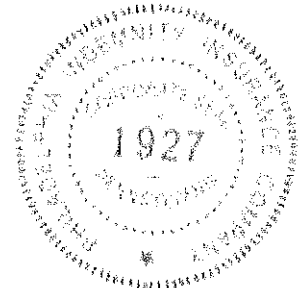



# PHILADELPHIA INSURANCE COMPANIES

A Member of the Tokio Marine Group

*Premium Based on Final Contract Price, Not Penal Sum*

Bond Number: PB11509801722

Initial Premium: \$4,075.00

## PAYMENT BOND

Take notice that CELSO GONZALEZ CONSTRUCTION, INC., 614 North Conway, Mission, TX 78572, as Principal, (hereinafter called "the Principal"), and PHILADELPHIA INDEMNITY INSURANCE COMPANY, One Bala Plaza, Suite 100, Bala Cynwyd, Pennsylvania 19004 as Surety (hereinafter called "the Surety"), are held and firmly bound unto Hidalgo County Purchasing Department, 2802 South Business Highway 281, Edinburg, TX 78539, as Obligee, (hereinafter called "the Obligee") for the use and benefit of Claimants as defined herein, in the amount of TWO HUNDRED FIVE THOUSAND AND 00/100 DOLLARS (\$205,000.00) (hereinafter called "the Penal Sum"), for the payment whereof the Principal and the Surety bind themselves, their heirs, executors, administrators, successors and assigns, jointly and severally, firmly by these presents.

WHEREAS, the Principal has by written agreement dated 1/1, entered into a contract with Obligee for RFB No : 2019-267-04-15-ABV - Construction of Bus Barn for Hidalgo County Sheriff's Office (hereinafter called "the Contract").

NOW THEREFORE, THE CONDITION OF THIS OBLIGATION is such that, if the Principal shall pay for labor, materials and equipment furnished by Claimants for use in the performance of the Principal's scope of work under the Contract (hereinafter collectively called "the Construction Work"), then this obligation shall be null and void, otherwise it shall remain in full force and effect subject to the terms and conditions of this Payment Bond.

8. Although the Surety waives notice of any reasonable modifications to the terms of the Contract, the Surety's obligations to Claimants under this Payment Bond are expressly conditioned upon:
  - a. Claimants employed by or having a direct contract with the Principal having furnished a Claim to the Surety.
  - b. Claimants, who do not have a direct contract with the Principal, having furnished a written notice of non-payment to the Principal, stating with substantial accuracy, the amount claimed and the name of the party to whom materials were, or equipment was, furnished or supplied or for whom the labor was done or performed, within ninety (90) days after having last performed or last furnished materials or equipment included in the Claim; and have sent a Claim to the Surety.
9. When a Claimant has satisfied the conditions of Paragraphs 1(a) or 1(b), whichever is applicable, the Surety shall take the following actions:
  - a. Send an answer to the Claimant within sixty (60) days after receipt of the Claim, stating the amounts that are undisputed and the basis for challenging the amounts that are disputed; and
  - b. Pay or arrange for payment of any undisputed amounts.

The Surety's failure to discharge its obligations under this Paragraph 2 shall not be deemed to constitute a waiver of defenses the Surety or Principal may have or acquire as to a Claim, except as to undisputed amounts for which the Surety and Claimant have reached agreement.

10. The Surety's total obligation shall not exceed the amount of Penal Sum of this Payment Bond and the Penal Sum shall be credited for any payments made by the Surety under this Payment Bond. The Penal Sum may only be modified by a written rider to this Payment Bond executed by an authorized representative of the Surety.



# PHILADELPHIA INSURANCE COMPANIES

A Member of the Tokio Marine Group

11. Principal and Oblige agree that all funds earned by Principal in the performance of the Construction Work are dedicated to satisfy obligations of the Principal and Surety under this Payment Bond. The Surety shall not be liable to the Oblige, Claimants or others for obligations of the Principal that are unrelated to the Construction Work. The Oblige shall not be liable for payment of any costs or expenses of any Claimant under this Payment Bond and shall have no obligation to make payments to, or give notice on behalf of, Claimants or otherwise have any obligations to Claimants under this Payment Bond
12. No suit or action shall be commenced under this Payment Bond by a Claimant other than in a court of competent jurisdiction in the state in which the project that is the subject of the Construction Work is located; and after the expiration of one year from the date (1) on which the Claimant sent a Claim to the Surety pursuant to Paragraph 2, or (2) on which the last labor or service was performed by Claimant or the last materials or equipment were furnished by Claimant, whichever of (1) or (2) first occurs.
13. Notice and Claims to the Surety or Principal shall be mailed or delivered to the addresses shown on the first page of this Payment Bond, and sent in compliance with any applicable statutory notice requirements.
14. When this Payment Bond has been furnished to comply with a statutory requirement, any provision in this Payment Bond conflicting with said statutory requirement shall be deemed deleted herefrom and the provisions conforming to such statutory requirement shall be deemed incorporated herein. When so furnished, the intent of this Payment Bond shall be construed as a statutory bond, and not as a common law bond.
15. Definitions:
  - a. Claim: A written statement by the Claimant including at a minimum:
    - i. The name and contact information of the Claimant;
    - ii. The name of the person or entity for whom labor was done or materials or equipment furnished;
    - iii. A brief description of the labor, materials or equipment furnished;
    - iv. The date on which the Claimant last performed labor or last furnished materials or equipment for use in the performance of the Construction Work;
    - v. The total amount due and unpaid to the Claimant for labor, materials or equipment furnished as of the date of the Claim.
  - b. Claimant: An individual or entity having a direct contract with the Principal or with a subcontractor of the Principal to furnish labor, materials or equipment for use in the performance of the Construction Work.

DATED:

CELSO GONZALEZ CONSTRUCTION, INC.  
(Principal)

By: \_\_\_\_\_

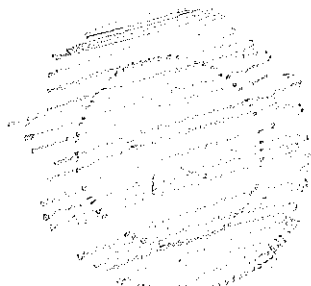

Philadelphia Indemnity Insurance Company  
(Surety)

By: \_\_\_\_\_

*[Handwritten Signature]*  
Fred A. Thetford, IV, Attorney In Fact

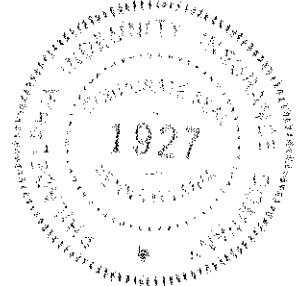

Bond No. PB11509801722

**PHILADELPHIA INDEMNITY INSURANCE COMPANY**  
One Bala Plaza, Suite 100  
Bala Cynwyd, PA 19004-0950

**Power of Attorney**

KNOW ALL PERSONS BY THESE PRESENTS: That **PHILADELPHIA INDEMNITY INSURANCE COMPANY** (the Company), a corporation organized and existing under the laws of the Commonwealth of Pennsylvania, does hereby constitute and appoint **Jared Young, Fred A. Thetford, Jr., Tobin Tucker, Tom Young, Diane Brown, Fred A. Thetford IV and/or Fred A. Thetford, III** of **Contract Bond Agency, LLC.**, its true and lawful Attorney-in-fact with full authority to execute on its behalf bonds, undertakings, recognizances and other contracts of indemnity and writings obligatory in the nature thereof, issued in the course of its business and to bind the Company thereby, in an amount not to exceed **\$50,000,000**.

This Power of Attorney is granted and is signed and sealed by facsimile under and by the authority of the following Resolution adopted by the Board of Directors of **PHILADELPHIA INDEMNITY INSURANCE COMPANY** on the 14<sup>th</sup> of November, 2016.

**RESOLVED:** That the Board of Directors hereby authorizes the President or any Vice President of the Company: (1) Appoint Attorney(s) in Fact and authorize the Attorney(s) in Fact to execute on behalf of the Company bonds and undertakings, contracts of indemnity and other writings obligatory in the nature thereof and to attach the seal of the Company thereto; and (2) to remove, at any time, any such Attorney-in-Fact and revoke the authority given. And, be it

**FURTHER RESOLVED:** That the signatures of such officers and the seal of the Company may be affixed to any such Power of Attorney or certificate relating thereto by facsimile, and any such Power of Attorney so executed and certified by facsimile signatures and facsimile seal shall be valid and binding upon the Company in the future with respect to any bond or undertaking to which it is attached.

IN TESTIMONY WHEREOF, **PHILADELPHIA INDEMNITY INSURANCE COMPANY** HAS CAUSED THIS INSTRUMENT TO BE SIGNED AND ITS CORPORATE SEAL TO BE AFFIXED BY ITS AUTHORIZED OFFICE THIS 27<sup>TH</sup> DAY OF OCTOBER, 2017.

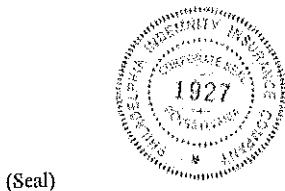

(Seal)

Robert D. O'Leary Jr., President & CEO  
Philadelphia Indemnity Insurance Company

On this 27<sup>th</sup> day of October, 2017, before me came the individual who executed the preceding instrument, to me personally known, and being by me duly sworn said that he is the therein described and authorized officer of the **PHILADELPHIA INDEMNITY INSURANCE COMPANY**; that the seal affixed to said instrument is the Corporate seal of said Company; that the said Corporate Seal and his signature were duly affixed.

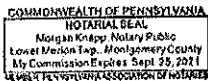

(Notary Seal)

Notary Public: Morgan Knapp  
residing at: Bala Cynwyd, PA  
My commission expires: September 25, 2021

I, Edward Sayago, Corporate Secretary of **PHILADELPHIA INDEMNITY INSURANCE COMPANY**, do hereby certify that the foregoing resolution of the Board of Directors and the Power of Attorney issued pursuant thereto on the 27<sup>th</sup> day of October, 2017 are true and correct and are still in full force and effect. I do further certify that Robert D. O'Leary Jr., who executed the Power of Attorney as President, was on the date of execution of the attached Power of Attorney the duly elected President of **PHILADELPHIA INDEMNITY INSURANCE COMPANY**.

In Testimony Whereof I have subscribed my name and affixed the facsimile seal of each Company this \_\_\_\_\_ day of \_\_\_\_\_, 20\_\_\_\_.



Edward Sayago, Corporate Secretary  
**PHILADELPHIA INDEMNITY INSURANCE COMPANY**

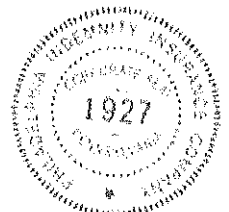



# PHILADELPHIA INSURANCE COMPANIES

A Member of the Tokio Marine Group

One Bala Plaza, Suite 100, Bala Cynwyd, Pennsylvania 19004  
610.617.7900 • Fax 610.617.7940 • PHLY.com

## SURETY BOND SEAL ADDENDUM

### *PHILADELPHIA INDEMNITY INSURANCE COMPANY*

As part of its business continuity efforts during the pendency of the COVID-19 pandemic, Philadelphia Indemnity Insurance Company ("PIIC") has temporarily authorized its Attorneys-in-Fact to affix PIIC's corporate seal in a digital format in lieu of its traditional raised seal to any bond issued on its behalf by any such Attorney-in-Fact.

PIIC agrees and affirms that the digital corporate seal found herein is deemed affixed to the bond and the Power of Attorney with the same effect as if its raised corporate seal had been affixed to the bond itself.

Effective this 20<sup>TH</sup> day of March, 2020.

Philadelphia Indemnity Insurance Company

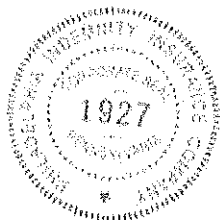

By: \_\_\_\_\_

Michael Cundiff, Senior Vice President

## IMPORTANT NOTICE

To obtain information or make a complaint:  
You may call the Surety's toll free telephone  
number for information or to make a  
complaint at:

**1-877-438-7459**

You may also write Philadelphia Indemnity  
Insurance Company at:

One Bala Plaza, Suite 100  
Bala Cynwyd, PA 19004  
Attention: Senior Vice President and  
Director of Surety

You may contact the Texas Department of  
Insurance to obtain information on  
companies, coverage, rights or complaints  
at:

**1-800-252-3439.**

You may write the Texas Department of  
Insurance at:

P.O. Box 149104  
Austin, TX 78714-9104  
Fax# 512-475-1771  
Web: <http://www.tdi.state.tx.us>  
Email: [ConsumerProtection@tdi.state.tx.us](mailto:ConsumerProtection@tdi.state.tx.us)

**PREMIUM OR CLAIM DISPUTES:** Should  
you have a dispute concerning your  
premium or about a claim, you should  
contact the Surety first. If the dispute is not  
resolved, you may contact the Texas  
Department of Insurance.

**ATTACH THIS NOTICE TO YOUR POLICY:**  
This notice is for information only and does  
not become a part or condition of the  
attached document.

## ADVISO IMPORTANTE

Para obtener informacion o para someter una  
queja: Usted puede llamar al numero de  
telefono gratis de para informacion o para  
someter una queja al:

**1-877-438-7459**

Usted tambien puede escribir a Philadelphia  
Indemnity Insurance Company at:

One Bala Plaza, Suite 100  
Bala Cynwyd, PA 19004  
Attention: Senior Vice President and  
Director of Surety

Puede comunicarse con el Departamento de  
Seguros de Texas para obtener information  
acerca de companias, coberturas, derechos  
o quejas al:

**1-800-252-3439**

Puede escribir al Departamento de Seguros  
de Texas:

P.O. Box 149104  
Austin, TX 78714-9104  
Fax# 512-475-1771  
Web: <http://www.tdi.state.tx.us>  
Email: [ConsumerProtection@tdi.state.tx.us](mailto:ConsumerProtection@tdi.state.tx.us)

**DISPUTAS SOBRE PRIMAS O  
RECLAMOS:** Si tiene una disputa  
concerniente a su prima o a un reclamo,  
debe comunicarse con el Surety primero. Si  
no se resuelve la disputa, puede entonces  
comunicarse con el departamento (TDI).

**UNA ESTE AVISO A SU POLIZA:** Este  
aviso es solo para proposito de informacion  
y no se convierte en parte o condicion del  
documento adjunto.

# **EXHIBIT “A”**

## **REQUEST FOR BIDS (RFB) PROCUREMENT PROGRAM**



2812 S. Bus. Hwy 281  
Edinburg, Texas 78539  
Phone: (956) 318-2626  
Fax: (956) 318-2629  
www.co.hidalgo.tx.us/purchasing

April 6, 2020

Re: Addendum No. 1

RFB No: 2019-267-04-15-ABV

**Hidalgo County - “Construction of Bus Barn for Hidalgo County Sheriff’s Office”**

Dear Bidder:

Attached you will find **ADDENDUM NO. 1**, in connection with **“HIDALGO COUNTY”** Request for Bids (RFB) for **“Construction of Bus Barn for Hidalgo County Sheriff’s Office”**

Please add this **ADDENDUM NO. 1** to your response, to permit your company to submit a complete packet. See original packet LEGAL NOTICE page 3, paragraph 4 number 9.

**Acknowledge receipt of ADDENDUM NO. 1** by signing and returning this notice to us VIA E-MAIL TO: [alexandra.vela@co.hidalgo.tx.us](mailto:alexandra.vela@co.hidalgo.tx.us).

If you do not receive all two (2) pages of **ADDENDUM NO. 1** please notify us immediately at (956) 318-2626 ext-4865.

Please be advised that this **ADDENDUM NO. 1** will complete your response for **Hidalgo County “Construction of Bus Barn for Hidalgo County Sheriff’s Office”**.

Thank you for your prompt attention to this matter.

BY: Alexandra Vela  
Alexandra Vela, Contract Specialist II  
Hidalgo County Purchasing Department

BY: \_\_\_\_\_  
ADDENDUM NO. 1  
ACKNOWLEDEMENT OF RECEIPT

BY: \_\_\_\_\_  
Print Name

Enclosure

# **ADDENDUM NO. 1**

April 6, 2020

**RFB No. 2019-267-04-15-ABV**

*Hidalgo County*

**“Construction of Bus Barn for Hidalgo County Sheriff’s Office”**

## **PLEASE NOTE THE FOLLOWING CLARIFICATIONS:**

**PRE-BID CONFERENCE** is scheduled for ~~Tuesday~~, April 08, 2020 at 3:30 P.M. at HIDALGO COUNTY NEW ADMINISTRATION BUILDING-PURCHASING DEPARTMENT 2812 S Business Hwy 281, EDINBURG, TEXAS 78539.

**PRE-BID CONFERENCE IS SCHEDULED FOR WEDNESDAY, APRIL 08, 2020 at 3:30 p.m.**

Typed written bidding RFI’s shall be e-mailed to alexandra.vela@co.hidalgo.tx.us. RFI’s **will not be answered by phone**. NO HAND WRITTEN RFI’S will be processed/answered. All inquiries shall be forwarded by **5:00 p.m. ~~Monday~~ April 08, 2020**. Responses to said inquiries will be sent to all applicants via facsimile by no later than **5:00 p.m. ~~Wednesday~~ April 10, 2020**. Inquiries beyond this date will not be responded to. Contact project architect’s office for copies of Addenda. All bidders who paid a deposit will be required to return Addenda as part of the Construction Documents in order to receive full deposit or refund.

**All inquiries shall be forwarded by 5:00 p.m. Wednesday April 08, 2020. Responses to said inquiries will be sent to all applicants via facsimile by no later than 5:00 p.m. Friday April 10, 2020.**

Please add this Addendum No 1 to your Response (RFB) so as to permit your company to submit a complete response.

I, \_\_\_\_\_, acknowledge receipt of  
ADDENDUM NO. 1 dated, April 6, 2020 ***RFB NO.:2019-267-04-15-ABV- Hidalgo County***  
**“Construction of Bus Barn for Hidalgo County Sheriff’s Office ”**

\_\_\_\_\_  
Printed Name

\_\_\_\_\_  
Date

**NOTE: PLEASE SUBMIT THIS ADDENDUM WITH YOUR RESPONSE IN ORDER TO COMPLETE YOUR RESPONSE.**



5000 West Military, Ste 100  
McAllen, Texas 78503  
(956) 664-0286  
Fax (956) 664-0282

## **ADDENDUM 2**

**To:** Proposed bidders  
**Date:** 4-07-2020  
**From:** Jose Gonzalez, PE  
**AVO:** 34015.004  
**Email:** Jose.gonzalez@halff.com  
**Project:** Hidalgo Country Sherriff Office Bus Barn  
**Subject:** Addendum 2

---

The following is a list of changes made to the plans. The changes are outlined by item number, as well as plan sheet number.

### Drawings:

- ITEM 1. Refer to Sheet E1.04  
a. Revised lighting fixture schedule part numbers.

Attachments: Sketches with changes/additions or deletion.

Copies: File

**KEY NOTES:**

1. TRIPPER ARE INSTALLED PER 60/25 BREAKER IN EXISTING SPACE. CIRCUIT BREAKERS TO MATCH EXISTING SHORT CIRCUIT RATING.
2. ALL NEW ELECTRICAL WORK SHALL BE INSTALLED IN EXISTING CONDUIT UNLESS OTHERWISE NOTED. REFER TO SHEET E102 FOR PROPOSED LOCATIONS.

TYPE	MANUF & MODEL NUMBER	DESCRIPTION	VOLTS	AMPS	PHASES	NOTES
A	TRIPPER 60/25	TRIPPER 60/25	480	25	3	
AE	TRIPPER 60/25	TRIPPER 60/25	480	25	3	
B	TRIPPER 60/25	TRIPPER 60/25	480	25	3	
BE	TRIPPER 60/25	TRIPPER 60/25	480	25	3	

**LIGHTING FIXTURE SCHEDULE**

TYPE	MANUF & MODEL NUMBER	DESCRIPTION	VOLTS	AMPS	PHASES	NOTES
A	TRIPPER 60/25	TRIPPER 60/25	480	25	3	
AE	TRIPPER 60/25	TRIPPER 60/25	480	25	3	
B	TRIPPER 60/25	TRIPPER 60/25	480	25	3	
BE	TRIPPER 60/25	TRIPPER 60/25	480	25	3	

**PANELBOARD A**

NO.	TYPE	MANUF & MODEL NUMBER	DESCRIPTION	VOLTS	AMPS	PHASES	NOTES
1	TRIPPER	60/25	TRIPPER 60/25	480	25	3	
2	TRIPPER	60/25	TRIPPER 60/25	480	25	3	
3	TRIPPER	60/25	TRIPPER 60/25	480	25	3	
4	TRIPPER	60/25	TRIPPER 60/25	480	25	3	
5	TRIPPER	60/25	TRIPPER 60/25	480	25	3	
6	TRIPPER	60/25	TRIPPER 60/25	480	25	3	
7	TRIPPER	60/25	TRIPPER 60/25	480	25	3	
8	TRIPPER	60/25	TRIPPER 60/25	480	25	3	
9	TRIPPER	60/25	TRIPPER 60/25	480	25	3	
10	TRIPPER	60/25	TRIPPER 60/25	480	25	3	
11	TRIPPER	60/25	TRIPPER 60/25	480	25	3	
12	TRIPPER	60/25	TRIPPER 60/25	480	25	3	
13	TRIPPER	60/25	TRIPPER 60/25	480	25	3	
14	TRIPPER	60/25	TRIPPER 60/25	480	25	3	
15	TRIPPER	60/25	TRIPPER 60/25	480	25	3	
16	TRIPPER	60/25	TRIPPER 60/25	480	25	3	
17	TRIPPER	60/25	TRIPPER 60/25	480	25	3	
18	TRIPPER	60/25	TRIPPER 60/25	480	25	3	
19	TRIPPER	60/25	TRIPPER 60/25	480	25	3	
20	TRIPPER	60/25	TRIPPER 60/25	480	25	3	
21	TRIPPER	60/25	TRIPPER 60/25	480	25	3	
22	TRIPPER	60/25	TRIPPER 60/25	480	25	3	
23	TRIPPER	60/25	TRIPPER 60/25	480	25	3	
24	TRIPPER	60/25	TRIPPER 60/25	480	25	3	
25	TRIPPER	60/25	TRIPPER 60/25	480	25	3	

**02 PROPOSED PARTIAL ONE-LINE DIAGRAM**

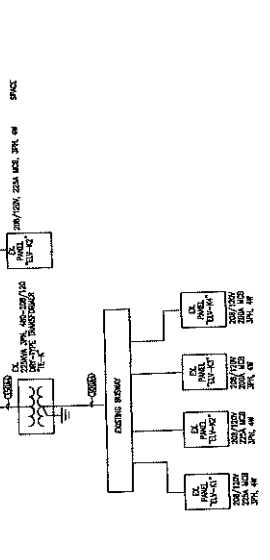
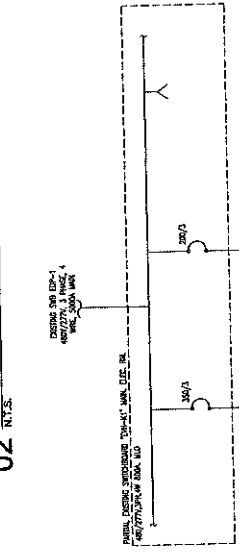

**01 EXISTING PARTIAL ONE-LINE DIAGRAM**

HCSO BUS BARN  
HIDALGO COUNTY CONTRACT  
#C-18-142-05-08  
EDINBURG, TX 75841



NO.	DATE	DESCRIPTION
1	04/20/20	APPROVED



NO.	DATE	DESCRIPTION
1	04/20/20	APPROVED

E104



2812 S. Bus. Hwy 281  
Edinburg, Texas 78539  
Phone: (956) 318-2626  
Fax: (956) 318-2629  
www.co.hidalgo.tx.us/purchasing

April 7, 2020

Re: Addendum No. 3

RFB No: 2019-267-04-15-ABV

**Hidalgo County - “Construction of Bus Barn for Hidalgo County Sheriff’s Office”**

Dear Bidder:

Attached you will find **ADDENDUM NO. 3**, in connection with **“HIDALGO COUNTY”** Request for Bids (RFB) for **“Construction of Bus Barn for Hidalgo County Sheriff’s Office”**

Please add this **ADDENDUM NO. 3** to your response, to permit your company to submit a complete packet. See original packet LEGAL NOTICE page 3, paragraph 4 number 9.

**Acknowledge receipt of ADDENDUM NO. 3** by signing and returning this notice to us VIA E-MAIL TO: [alexandra.vela@co.hidalgo.tx.us](mailto:alexandra.vela@co.hidalgo.tx.us).

If you do not receive all two (2) pages of **ADDENDUM NO. 3** please notify us immediately at (956) 318-2626 ext-4865.

Please be advised that this **ADDENDUM NO. 3** will complete your response for **Hidalgo County “Construction of Bus Barn for Hidalgo County Sheriff’s Office”**.

Thank you for your prompt attention to this matter.

BY: Alexandra Vela  
Alexandra Vela, Contract Specialist II  
Hidalgo County Purchasing Department

BY: \_\_\_\_\_  
ADDENDUM NO. 3  
ACKNOWLEDEMENT OF RECEIPT

BY: \_\_\_\_\_  
Print Name

Enclosure

# **ADDENDUM NO. 3**

April 7, 2020

**RFB No. 2019-267-04-15-ABV**

*Hidalgo County*

**“Construction of Bus Barn for Hidalgo County Sheriff’s Office”**

## **PLEASE NOTE THE FOLLOWING CHANGES:**

RFB PRE-BID CONFERENCE Date: ~~Wednesday, April 08, 2020 at 3:30 P.M.~~ has been changed:

1. **New Pre-Bid Conference Setting: Wednesday, April 08, 2020 at 3:30 P.M.**  
**via Google Hangouts:**
  - Join Hangouts Meet: [meet.google.com/rjz-myxx-ihm](https://meet.google.com/rjz-myxx-ihm)
  - Join by phone: +1 219-301-2120 PIN: 744 799 057#

Please add this Addendum No 3 to your Response (RFB) so as to permit your company to submit a complete response.

I, \_\_\_\_\_, acknowledge receipt of ADDENDUM NO. 3 dated, April 7, 2020 **RFB NO.:2019-267-04-15-ABV- Hidalgo County “Construction of Bus Barn for Hidalgo County Sheriff’s Office”**

\_\_\_\_\_  
Printed Name

\_\_\_\_\_  
Date

**NOTE: PLEASE SUBMIT THIS ADDENDUM WITH YOUR RESPONSE IN ORDER TO COMPLETE YOUR RESPONSE.**



2812 S. Bus. Hwy 281  
Edinburg, Texas 78539  
Phone: (956) 318-2626  
Fax: (956) 318-2629  
www.co.hidalgo.tx.us/purchasing

April 7, 2020

Re: Addendum No. 4

RFB No: 2019-267-04-15-ABV

Hidalgo County - “Construction of Bus Barn for Hidalgo County Sheriff’s Office”

Dear Bidder:

Attached you will find **ADDENDUM NO. 4**, in connection with **“HIDALGO COUNTY”** Request for Bids (RFB) for “Construction of Bus Barn for Hidalgo County Sheriff’s Office”

Please add this **ADDENDUM NO. 4** to your response, to permit your company to submit a complete packet. See original packet LEGAL NOTICE page 3, paragraph 4 number 9.

**Acknowledge receipt of ADDENDUM NO. 4** by signing and returning this notice to us VIA E-MAIL TO: [alexandra.vela@co.hidalgo.tx.us](mailto:alexandra.vela@co.hidalgo.tx.us).

If you do not receive all two (2) pages of **ADDENDUM NO. 4** please notify us immediately at (956) 318-2626 ext-4865.

Please be advised that this **ADDENDUM NO. 4** will complete your response for *Hidalgo County* “Construction of Bus Barn for Hidalgo County Sheriff’s Office”.

Thank you for your prompt attention to this matter.

BY: Alexandra Vela  
Alexandra Vela, Contract Specialist II  
Hidalgo County Purchasing Department

BY: \_\_\_\_\_  
ADDENDUM NO. 4  
ACKNOWLEDEMENT OF RECEIPT

BY: \_\_\_\_\_  
Print Name

Enclosure

# **ADDENDUM NO. 4**

April 7, 2020

**RFB No. 2019-267-04-15-ABV**

*Hidalgo County*

**“Construction of Bus Barn for Hidalgo County Sheriff’s Office”**

## **PLEASE NOTE THE FOLLOWING CHANGES:**

Typed written bidding RFI’s shall be e-mailed to alexandra.vela@co.hidalgo.tx.us. RFI’s **will not be answered by phone**. NO HAND WRITTEN RFI’S will be processed/answered. All inquiries shall be forwarded by ~~5:00 PM Monday April 08, 2020~~. Responses to said inquiries will be sent to all applicants via facsimile by no later than ~~5:00 p.m. Wednesday April 10, 2020~~. Inquiries beyond this date will not be responded to. Contact project architect’s office for copies of Addenda. All bidders who paid a deposit will be required to return Addenda as part of the Construction Documents in order to receive full deposit or refund.

1. **NEW All inquiries shall be forwarded by 5:00 PM Friday April 10, 2020. Responses to said inquiries will be sent to all applicants via facsimile by no later than 5:00 p.m. MONDAY April 13, 2020.**

Please add this Addendum No 4 to your Response (RFB) so as to permit your company to submit a complete response.

I, \_\_\_\_\_, acknowledge receipt of ADDENDUM NO. 4 dated, April 8, 2020 **RFB NO.:2019-267-04-15-ABV- Hidalgo County “Construction of Bus Barn for Hidalgo County Sheriff’s Office ”**

\_\_\_\_\_  
Printed Name

\_\_\_\_\_  
Date

**NOTE: PLEASE SUBMIT THIS ADDENDUM WITH YOUR RESPONSE IN ORDER TO COMPLETE YOUR RESPONSE.**



2812 S. Bus. Hwy 281  
Edinburg, Texas 78539  
Phone: (956) 318-2626  
Fax: (956) 318-2629  
[www.co.hidalgo.tx.us/purchasing](http://www.co.hidalgo.tx.us/purchasing)

April 7, 2020

Re: Addendum No. 5

RFB No: 2019-267-04-15-ABV

Hidalgo County - "Construction of Bus Barn for Hidalgo County Sheriff's Office"

Dear Bidder:

Attached you will find **ADDENDUM NO. 5**, in connection with **"HIDALGO COUNTY"** Request for Bids (RFB) for "Construction of Bus Barn for Hidalgo County Sheriff's Office"

Please add this **ADDENDUM NO. 5** to your response, to permit your company to submit a complete packet. See original packet LEGAL NOTICE page 3, paragraph 4 number 9.

Acknowledge receipt of ADDENDUM NO. 5 by signing and returning this notice to us VIA E-MAIL TO: [alexandra.vela@co.hidalgo.tx.us](mailto:alexandra.vela@co.hidalgo.tx.us).

If you do not receive all two (3) pages of **ADDENDUM NO. 5** please notify us immediately at (956) 318-2626 ext-4865.

Please be advised that this **ADDENDUM NO. 5** will complete your response for *Hidalgo County* "Construction of Bus Barn for Hidalgo County Sheriff's Office".

Thank you for your prompt attention to this matter

BY: Martha L. Salazar  
Martha L. Salazar, CPPB  
Hidalgo County Purchasing Agent

BY: \_\_\_\_\_  
ADDENDUM NO. 5  
ACKNOWLEDEMENT OF RECEIPT

BY: \_\_\_\_\_  
Print Name

Enclosures  
MLS/abv

## **ADDENDUM NO. 5**

April 13, 2020

**RFB No. 2019-267-04-15-ABV**

***Hidalgo County***

**“Construction of Bus Barn for Hidalgo County Sheriff’s Office”**

### **PLEASE NOTE THE FOLLOWING CHANGES:**

1. **Add Memorandum dated April 13, 2020 to the Procurement Packet:**

**New Bid-Opening Setting: Wednesday, April 15, 2020 at 9:30 A.M.  
via Google Hangouts:**

- **Join Hangouts Meet:** <https://meet.google.com/yqs-kvwwg-ypg?hs=122>
- **Join by phone:** +1 929-287-3362 PIN: 145 136 330#
- **Watch live Stream:**  
<https://stream.meet.google.com/stream/d463a117-0d75-4370-ac53-05812cd57275>

Please add this Addendum No 5 to your Response (RFB) so as to permit your company to submit a complete response.

I, \_\_\_\_\_, acknowledge receipt of ADDENDUM NO. 5 dated, April 13, 2020 *RFB NO.:2019-267-04-15-ABV- Hidalgo County “Construction of Bus Barn for Hidalgo County Sheriff’s Office”*

\_\_\_\_\_  
Printed Name

\_\_\_\_\_  
Date

**NOTE:** **PLEASE SUBMIT THIS ADDENDUM WITH YOUR RESPONSE IN ORDER TO COMPLETE YOUR RESPONSE.**



2812 S. Bus. Hwy 281  
Edinburg, Texas 78539  
Phone: (956) 318-2626  
Fax: (956) 318-2629  
[www.co.hidalgo.tx.us/purchasing](http://www.co.hidalgo.tx.us/purchasing)

## MEMORANDUM

TO: All participants

FROM: Martha L. Salazar, CPPB

DATE: Monday, April 13, 2020

SUBJECT: Video conference for Bid Openings for the date of April 15, 2020

---

Given the fluidity of the COVID-19 pandemic, and in accordance with the Shelter in Place Order by Hidalgo County Judge, Richard F. Cortez, the Purchasing Department will limit the amount of personnel in our conference room during Bid Openings. Bid Openings for **April 15, 2020, only designated personnel will be allowed in the conference room.** Our Bid Openings will continue to be held at 9:30am. All other personnel may view the Bid Openings live online via a Google Hangouts:

- **Join Hangouts Meet:** <https://meet.google.com/yqs-kwvg-ypg?hs=122>
- **Watch live stream:** <https://stream.meet.google.com/stream/d463a117-0d75-4370-ac53-05812cd57275>
- **Join by phone:** +1 929-287-3362 PIN: 145 136 330#

While we work on a more permanent solution, the links will be shared with all participants who requested a procurement packet directly from our office.

The above links may be shared with others who you wish to join the video conference call. To ensure no disturbances, all participants on the video conference call will be on mute, with the exception of the host (the Purchasing Department).

For vendors who plan on submitting a response, **please plan accordingly and give yourself ample time as we will limit the number of people allowed in our lobby.** Our office will not be responsible for responses that are not accepted past 9:30am due to the number of people in our lobby.

MLS/abv

CC: Raul Garcia Jr., Halff Associates, Inc.  
Carolyn Thornton, County Clerk's Office



2812 S. Bus. Hwy 281  
Edinburg, Texas 78539  
Phone: (956) 318-2626  
Fax: (956) 318-2629  
[www.co.hidalgo.tx.us/purchasing](http://www.co.hidalgo.tx.us/purchasing)

April 7, 2020

Re: Addendum No. 6

RFB No: 2019-267-04-15-ABV

Hidalgo County - "Construction of Bus Barn for Hidalgo County Sheriff's Office"

Dear Bidder:

Attached you will find **ADDENDUM NO. 6**, in connection with **"HIDALGO COUNTY"** Request for Bids (RFB) for "Construction of Bus Barn for Hidalgo County Sheriff's Office"

Please add this **ADDENDUM NO. 6** to your response, to permit your company to submit a complete packet. See original packet LEGAL NOTICE page 3, paragraph 4 number 9.

Acknowledge receipt of ADDENDUM NO. 6 by signing and returning this notice to us VIA E-MAIL TO: [alexandra.vela@co.hidalgo.tx.us](mailto:alexandra.vela@co.hidalgo.tx.us).

If you do not receive all pages of **ADDENDUM NO. 6** please notify us immediately at (956) 318-2626 ext-4865.

Please be advised that this **ADDENDUM NO. 6** will complete your response for *Hidalgo County* "Construction of Bus Barn for Hidalgo County Sheriff's Office".

Thank you for your prompt attention to this matter.

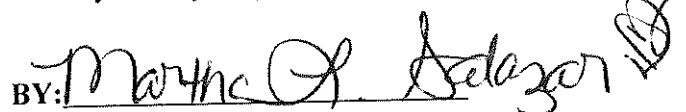
BY:   
Martha L. Salazar, CPPB  
Hidalgo County Purchasing Department

BY: \_\_\_\_\_  
ADDENDUM NO. 6  
ACKNOWLEDEMENT OF RECEIPT

BY: \_\_\_\_\_  
Print Name

Enclosure

**ADDENDUM NO. 6**

April 13, 2020

**RFB No. 2019-267-04-15-ABV**

***Hidalgo County***

**“Construction of Bus Barn for Hidalgo County Sheriff’s Office”**

**PLEASE NOTE THE FOLLOWING CHANGES:**

**The following pages are a list of changes made to the plans and clarifications to questions asked.**

Please add this Addendum No 6 to your Response (RFB) so as to permit your company to submit a complete response.

I, \_\_\_\_\_, acknowledge receipt of ADDENDUM NO. 6 dated, April 13, 2020 ***RFB NO.:2019-267-04-15-ABV- Hidalgo County “Construction of Bus Barn for Hidalgo County Sheriff’s Office ”***

\_\_\_\_\_  
Printed Name

\_\_\_\_\_  
Date

**NOTE: PLEASE SUBMIT THIS ADDENDUM WITH YOUR RESPONSE IN ORDER TO COMPLETE YOUR RESPONSE.**



5000 West Military, Ste 100  
McAllen, Texas 78503  
(956) 664-0286  
Fax (956) 664-0282

## ADDENDUM 6

**To:** Proposed bidders  
**From:** Raul Garcia Jr, PE  
**Email:** rgarcia@halff.com  
**Subject:** Addendum 6

**Date:** 4-13-2020  
**AVO:** 34015.004  
**Project:** Hidalgo Country Sherriff Office Bus Barn

---

The following is a list of changes made to the plans. The changes are outlined by item number, as well as plan sheet number.

### Clarifications:

- ITEM 1. There is no estimated budget for this project.
- ITEM 2. All technical specifications are included on the plan set. No separate set of technical specifications will be provided.
- ITEM 3. The building is not fully enclosed. There are walls on 3 sides of the building (North, West, and East) that extend to 3 ft from ground.
- ITEM 4. Architectural plans with elevations will not be provided.
- ITEM 5. The structure will have metal siding with color and finish to match existing Motor Pool Facility located at same location (Sheriff's Department Site).
- ITEM 6. There is no insulation on the building. It is an open structure.
- ITEM 7. The project shall be completed within 150 calendar days from Notice to Proceed.
- ITEM 8. No allowances or contingencies shall be included in the bid.
- ITEM 9. Owner shall be entitled to liquidated damages in the amount of \$250 per day that the work is not substantially complete.
- ITEM 10. No shop equipment will be required for this project.
- ITEM 11. Geotechnical Investigation is provided as an attachment to this Addendum.
- ITEM 12. Alternate #1 as shown on Sheet S2.0 shall be the base bid. Steel and connections will not be hot dipped galvanized.
- ITEM 13. All wall panels to stop at the top of the concrete pier / base.
- ITEM 14. Typical R-Panel installation is acceptable on a ½ to 12 slope. Contractor to coordinate with PEBM.



5000 West Military, Ste 100  
McAllen, Texas 78503  
(956) 664-0286  
Fax (956) 664-0282

**Attachment:** Geotechnical Investigation

Copies: File

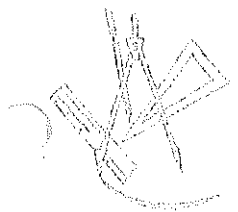

**L&G Engineering**

Transportation Consultants

**GEOTECHNICAL INVESTIGATION  
FOR THE  
HIDALGO COUNTY SHERIFF'S OFFICE BUS BARN PROJECT  
HIDALGO COUNTY, TEXAS**

**Prepared For:  
Hidalgo County Sheriff's Office / Hidalgo County Precinct No. 4**

**Prepared By:  
L&G Consulting Engineers, Inc.  
(L&G Engineering Laboratory – A Division of L&G)  
Mercedes, Texas 78570  
[Texas Registered Engineering Firm F-4105]**

**L&G Project No. G19009  
October 30, 2019**

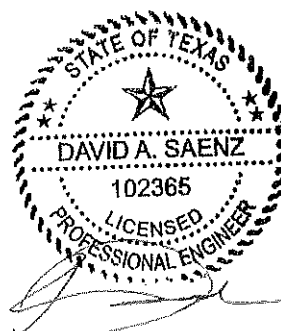

**David A. Saenz, P.E., C.F.M.  
Project Manager / Project Engineer**

10/30/2019

<b>INTRODUCTION.....</b>	<b>1</b>
<b>GENERAL PROJECT OVERVIEW .....</b>	<b>1</b>
Project Description .....	1
Scope and Limitations of Investigation.....	2
<b>EXISTING SURFACE AND SUB-SURFACE CONDITIONS .....</b>	<b>2</b>
Site Location / Description .....	2
Geology.....	2
Soil Survey .....	3
Rainfall.....	4
FEMA Flood Zone .....	4
<b>SITE INVESTIGATION.....</b>	<b>4</b>
Soil Borings and Laboratory Tests.....	4
Subsurface Stratigraphy .....	5
Water Strikes.....	5
<b>GEOTECHNICAL BORING ANALYSIS (LAB TESTING).....</b>	<b>5</b>
Moisture Content .....	5
Plasticity Index .....	5
Particle Size Analysis (Determination of Fines Content) .....	6
Sulfate Content of Soils (Concrete Structures) .....	6
<b>FOUNDATION ANALYSIS &amp; RECOMMENDATIONS .....</b>	<b>6</b>
Proposed Project Foundation System Information .....	6
Deep Foundation Capacity (Capacity Curves).....	6
Design and Analysis Background Information (Pavement – Access Drive).....	7
Index Testing & Soil Classification (Subgrade Soils) .....	7
Subgrade Analysis (Pavement – Access Drive) .....	8
Pavement Section Recommendations.....	8
Pavement Material Specification Recommendations .....	8
Flexible Base Material.....	8
Compacted Subgrade.....	9
<b>GENERAL CONSTRUCTION CONSIDERATIONS .....</b>	<b>9</b>
Deep Foundation Recommendations (Drilled Shafts) .....	9
Site Grading Recommendations .....	9
Site Drainage Recommendations.....	9
Site Preparation Recommendations.....	9
Embankment Recommendations.....	10
Select Fill & Structural Fill Recommendations .....	10
Excavation and Trenching Recommendations.....	12
Miscellaneous Pavement Recommendations .....	12
<b>REFERENCES.....</b>	<b>13</b>
<b>APPENDIX A – FIGURES .....</b>	<b>A</b>
<b>APPENDIX B – BORING LOGS.....</b>	<b>B</b>
<b>APPENDIX C – FOUNDATION CAPACITY CURVES .....</b>	<b>C</b>
<b>APPENDIX D – INFO PROVIDED BY CLIENT (REFERENCE).....</b>	<b>D</b>

# INTRODUCTION

L&G Consulting Engineers, Inc. (L&G Engineering Laboratory – A Division of L&G (L&G)) was contracted by Hidalgo County Sheriff's Office (HCSO) through a Hidalgo County Precinct No. 4 (HC Pct. 4) contract to perform a subsurface geotechnical investigation for the proposed HCSO Bus Barn Project (adding a covered bus barn and access drive on existing owned HCSO land within the HCSO complex). This report addresses evaluation of the site soils, deep foundation analysis (drilled shafts) and gravel drive recommendations. In addition, this report includes boring logs and figures addressing the existing geology of the proposed construction site.

# GENERAL PROJECT OVERVIEW

## Project Description

L&G is pleased to submit this document presenting our findings as the result of a subsurface geotechnical exploration performed at the request of HCSO. The project site is located in Edinburg, Texas, approximately three-quarter (0.75) miles east of Interstate 69 (I-69), and just north of El Cibolo Rd. It is our understanding that the project involves construction of a proposed 3-sided steel structure bus barn and gravel/caliche drive and floor to provide access to this structure. As per coordination with the Client and Client Prime Engineer for this project (HALFF), we understand the structure will be founded on drilled shaft foundations and the access drive and floor will be comprised of gravel/caliche (unpaved roadway section). No grading plans or structural loads were provided; thus all foundation and site improvement recommendations as provided in this report are based on the geotechnical properties of the soils and generalized assumptions as noted. An illustration of the project site is shown in Figure 1.

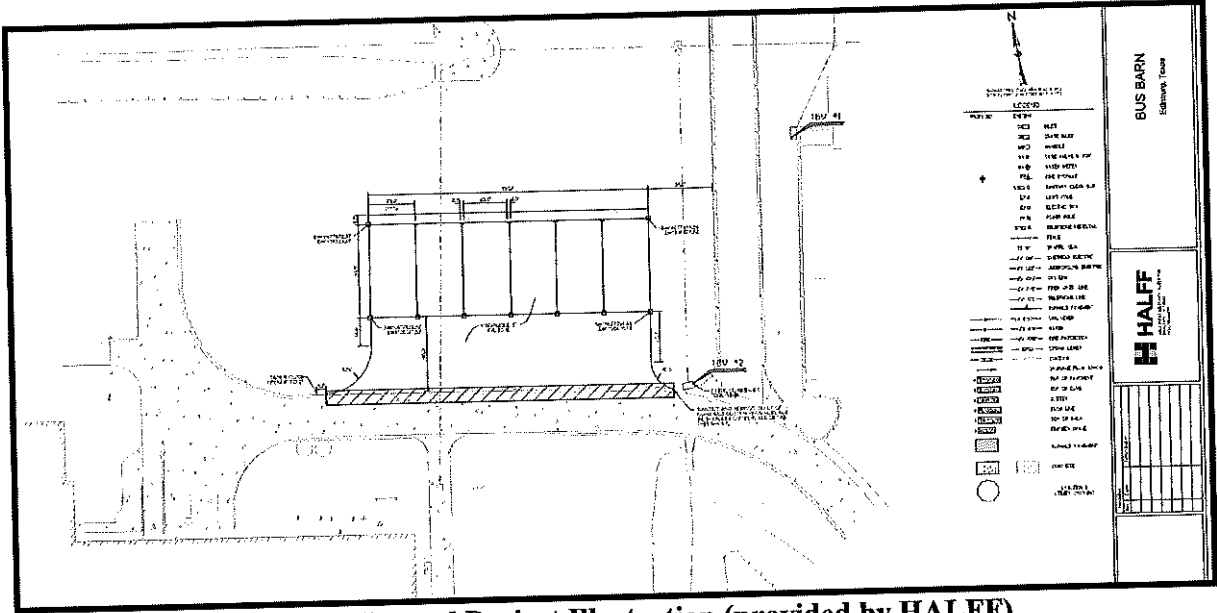

Figure 1 – General Project Illustration (provided by HALFF)

## Scope and Limitations of Investigation

This report has been prepared in general accordance with accepted geotechnical engineering practices for the subject project site and the anticipated construction. No specific warranty program or other special standards, except acceptable industry standards for the general South Texas area, were followed during the course of this investigation and analysis. This geotechnical report is intended for use by HCSO, and any direct representatives or affiliates. This geotechnical report may not contain sufficient information for purposes of other parties, or other uses in determining construction means and methods.

The strata, shown on the boring logs included in Appendix B, represent the subsurface conditions at each boring location at the time of our investigation. These strata designate approximate boundaries between subsurface materials; however, their actual transition may be gradual or may occur at varying depths. Variations may occur due to unexpected deposits of soft clays, silts or other undesirable soil material not detected through our investigation. It should be noted that the exploratory boring was performed within the limits of the proposed project as approved and agreed upon by all previously noted parties prior to the commencement of our field operations.

The benchmarks of this geotechnical study are to:

1. explore the general existing subsurface conditions at the site
2. evaluate the relevant engineering properties of the subsurface materials
3. provide analysis and foundation capacity curves for proposed drilled shaft foundations
4. provide analysis and pavement recommendations for proposed access drive and floor

The scope of this geotechnical engineering study does not include an environmental assessment of the air, soil, rock or water conditions on or adjacent to the site. No environmental opinions are presented in this report. If environmental clearances are needed prior to construction, please contact our offices for assistance in this matter.

## EXISTING SURFACE AND SUB-SURFACE CONDITIONS

### Site Location / Description

The project site is located in Edinburg, Texas, approximately three-quarter (0.75) miles east of Interstate 69 (I-69), and just north of El Cibolo Rd at the existing Hidalgo County Sheriff's Office. The borings were drilled as close as possible to the locations specified by the Client as shown in Appendix A. No surveyor was contracted to determine the exact coordinates for the borings, as this was not a part of the scope of work for the project; however, field handheld GPS coordinates were retrieved and are noted on the boring logs in Appendix B. Elevations were determined using approximate data as referenced from Google Earth. The property had minimal vegetation at the time of drilling (short grass).

### Geology

The Geologic Atlas of Texas, McAllen-Brownsville Sheet, dated 1976, indicates that the subject site is located within the Goliad Formation of the Tertiary epoch (Pliocene period). The description of the materials is as follows:

**Goliad Formation (Pg)** – “Clay, sand, sandstone, marl, caliche, limestone, and conglomerate; clay, commonly light shades of pink and green, calcareous concretions; sand and sandstone, medium to very coarse grained, in part crossbedded, mostly quartz, some black and red chert; conglomerate, black chert and dark siliceous granules and pebbles in calcareous (caliche) matrix; sandstone and conglomerate locally well bedded; marl and limestone poorly bedded or massive; Tertiary vertebrae and reworked Cretaceous invertebrate fossils fairly common; thickness up to 600 feet”.

**Soil Survey**

According to the Soil Survey of Hidalgo County, Texas, published by the United States Department of Agriculture, the proposed site encompasses the following soil map unit(s) along the alignment as shown in **Table 1** & **Figure 2**.

Map unit symbol	Map unit name	Rating	Acres in AOI	Percent of AOI
3	Brennan fine sandy loam, 0 to 1 percent slopes	SC-SM	0.3	40.6%
4	Brennan fine sandy loam, 0 to 3 percent slopes	SC-SM	0.4	59.4%
Totals for Area of Interest			0.7	100.0%

**Table 1 - Soil Survey Map Units for Project Limits**

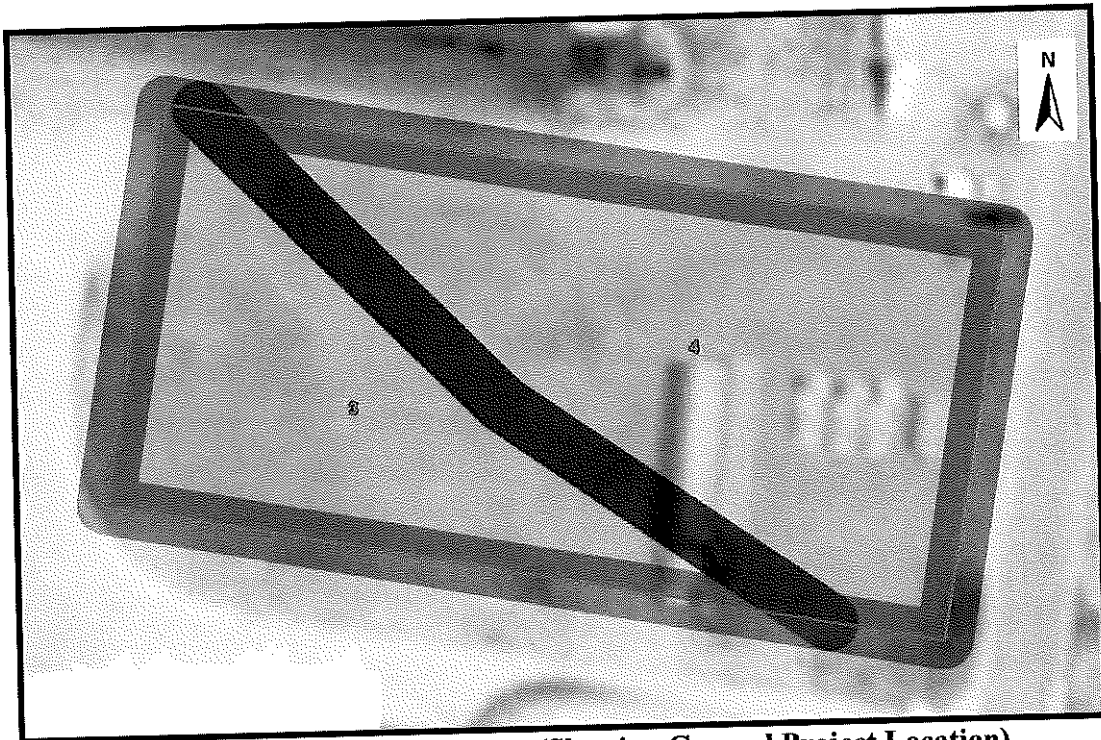

**Figure 2 - Soil Survey Mapping (Showing General Project Location)**

The soils map units for the most prevalent soils, as referenced from the Soil Survey of Hidalgo County, Texas, are described as follows:

**Brennan Fine Sandy Loam (0 to 1 and 0 to 3 percent slopes) (Soil Map Units #3 & 4)** –This unit is well drained with a moderate available water capacity (about 8.5 to 8.7 inches) and moderate permeability. It is non-saline to slightly saline (about 1.0 to 4.0 mmhos/cm) with no frequency of flooding or ponding. Soil Survey shows this soil unit to have average plasticity indices (PI = 10) and percent of sand (% coarse particle) of 66 (primarily lean clayey silty sand – USCS SC-SM). No major limitations in terms of the principal construction scope were noted with regard to these soils.

### **Rainfall**

The mean annual precipitation for this area of Hidalgo County is approximately 19-24 inches, as reported by the U.S. Department of Agriculture Soil Conservation Service. Our geotechnical investigation, performed in October 2019, was conducted during a non drought condition (D0, as noted by the National Weather Service and U.S. Drought Monitor). The National Oceanic and Atmospheric Administration (NOAA) reports for the subject dates indicated that no significant rainfall observations (at least one inch) occurred during our exploration.

### **FEMA Flood Zone**

The project site was referenced against the FEMA Flood Insurance Rate Maps (FIRM) included on the FEMA website (<https://msc.fema.gov/portal/home>). The site was found on Community-Panel Number 480334 0225 B with Effective Date noted as January 2, 1981. The project site area was noted as Zone C (areas of minimal flooding synonymous with areas outside the SFHA and higher than the elevation of the 0.2-percent-annual-chance flood).

## **SITE INVESTIGATION**

### **Soil Borings and Laboratory Tests**

Subsurface conditions at the site were evaluated through two (2) geotechnical borings (designated as B-#) drilled to a depth of thirty-five (35) feet below natural ground elevation at the locations shown on Figure 2 of Appendix A. The soil borings were drilled and sampled in general accordance with American Society of Testing Materials Procedures (ASTM) D1452 and D1586 using a truck mounted drilling rig (Simco 2800 HS (HT)) and solid stem augers.

### **Standard Penetration Testing (SPT)**

As part of the sampling procedures, split barrel (spoon) and Standard Penetration Tests (SPT) were performed and recorded. Standard Penetration Test results are noted on the boring log as blows per foot or twelve (12) inch increment. The sampler was advanced through three (3) consecutive six inch increments; however, the first six inch increment is considered the seating drive, which eliminates the effect of cuttings or disturbances on the test result. The sum of the blows for the last two six (6) inch increments is considered the “standard penetration resistance value” or “field N-value”. Where hard or very dense materials were encountered, the SPT was terminated and noted on the boring log when one of the following situations occurred:

1. a total of 50 blows were applied on one six inch increment
2. a total of 100 blows were applied during the test
3. no advancement of the sampler was observed during the application of ten (10) consecutive blows from the hammer

Representative portions of all samples (SPT/Split Barrel Sampling) were identified, packaged, sealed in containers to reduce moisture loss, and transported to our laboratory for subsequent testing. In the laboratory, each sample was evaluated and visually classified by a member of our geotechnical engineering staff. The properties of each stratum were evaluated by a series of laboratory index tests. A summary of the laboratory data and their corresponding depths are presented on the boring logs in Appendix B.

Samples will be retained in our laboratory for 30 days after submittal of this report. Other arrangements may be provided at the request of the Client to hold the samples through the construction process.

#### Subsurface Stratigraphy

The Soil Strata and Description are provided on the boring logs attached to this report and are a typical summarized representation of the site stratigraphy. The lines designating the interfaces between strata on the boring logs represent approximate boundaries. Transitions between strata may be gradual and may occur at varying depths. Detailed subsurface stratigraphy can be found on the boring logs in Appendix B.

#### Water Strikes

Water strikes were encountered at approximately 17-19 feet below existing ground (Elev. +70 to +72) at the boring locations. It should be noted that fluctuations in groundwater levels are influenced by variations in rainfall and surface water run-off from season to season. The construction process itself may also cause variations in the groundwater level. If the water level is critical to the construction process, **L&G** recommends that the Contractor check the subsurface water conditions immediately prior to construction excavation through the installation of piezometer wells.

### GEOTECHNICAL BORING ANALYSIS (LAB TESTING)

#### Moisture Content

The moisture content of a soil is defined as the ratio of the weight of the water in the sample to the dry weight of the soil sample. The moisture contents for the samples obtained as part of our geotechnical exploration were performed in compliance with ASTM procedure D2216 (and Tex-103-E). A comprehensive list of all moisture contents by corresponding depth can be found on the boring logs.

#### Plasticity Index

The Plasticity Index (PI) is defined as the difference between the liquid limit and the plastic limit of a soil. These limits are commonly referred to as the Atterberg limits, which describe the consistency of soils with respect to their varying moisture contents. The plasticity indices for the

samples obtained as part of our geotechnical exploration were performed in compliance with ASTM procedure D4318 (and Tex-104-E thru Tex-106-E). A comprehensive list of all plasticity indices by corresponding depth can be found on the boring logs.

**Particle Size Analysis (Determination of Fines Content)**

The standard grain size analysis is used to determine the relative proportions of different grain sizes as they are distributed along a range of different sized sieves. The minus 200 sieve analysis is used commonly as a tool for soil classification and identification using the Unified Soils Classification System. Results for this test are reported as a percentage of soil passing the No. 200 sieve, which has openings 0.075mm wide. The particle size analyses for the samples obtained as part of our geotechnical exploration were performed in compliance with ASTM procedure D1140 (and Tex-111-E). A comprehensive list of all fines contents by corresponding depth can be found on the boring logs.

**Sulfate Content of Soils (Concrete Structures)**

The presence of high concentrations of water-soluble sulfates (SO<sub>4</sub>) in soils can be detrimental to concrete structures in direct contact. Concrete exposed to these sulfate rich soils (buried concrete structures, foundations, slabs-on-grade) are vulnerable to deterioration in the form of expansion, cracking, and spalling. Sulfate testing was performed in accordance with TxDOT Tex-145-E at all boring locations. The results of the sulfate testing are as follows (see Table 2):

Boring No.	*Sample Depth	Sulfate Content (ppm)
B-01	4.5 – 6.0 ft	120
B-02	13.5 – 15.0 ft	180

**Table 2 - Sulfate Content Testing**

*\*all depths are referenced from existing natural ground*

**FOUNDATION ANALYSIS & RECOMMENDATIONS**

**Proposed Project Foundation System Information**

The proposed project involves the development of a 3-sided steel structure to be used as a Bus Barn (bus storage facility). In addition, the proposed project includes development of a drive and general structure floor to provide access to this structure. Our understanding from coordination with the Client is that the steel structure will be supported on drilled shaft foundations and the floor as well as access drive will be comprised of gravel / caliche.

**Deep Foundation Capacity (Capacity Curves)**

Standard Penetration Test (SPT) test results were used to calculate foundation capacity curves for various deep foundation options. Deep foundation options for use on this project could include various diameters of reinforced concrete drilled shafts. Design curves for four drilled shaft sizes most likely to be used (18, 24, 30, and 36 inch diameter) have been provided in Appendix C. If alternate foundation types or sizes are required for the project, L&G can provide alternate curves as needed. Capacity curves were generated through the Texas Department of Transportation (TxDOT) WINCORE software program (version 3.1). The foundation capacities

include the effects of point bearing and skin friction to account for total foundation capacity. The capacity curves were generated incorporating a disregard of the top 3 feet of each boring.

It is imperative for designers to note that the depth of foundation determined by way of the foundation capacity curves provided is a generalized model. Final foundation tip elevations should be determined with engineering judgment and modified based on each individual case. During final foundation design the foundation designer will need to take into account the final elevation of borings, final elevation of finished grade (groundline) at foundation elements and any additional disregarded depth that may be deemed necessary.

**Design and Analysis Background Information (Pavement – Access Drive)**

The pavement recommendations contained in this report were limited to the data recovered from the field and laboratory testing performed for the borings. No traffic loading data was presented for the future proposed drive.

Our recommendations are based on design procedures found in the Army Corps of Engineers Manuals EM 1110-3-131 (Flexible Pavement Design), and our experience with similar soils and site conditions. The design index selection utilized in the design process was based on classification of the area as a motor pool / motor storage area for pneumatic-tired vehicles (Design Index selected was 2).

**Index Testing & Soil Classification (Subgrade Soils)**

Soils slated for access drive subgrade on this project (in the upper 0 to 5 feet of soil profile as per Client directive) were investigated at this site for overall index properties. Index tests (Moisture Content, Atterberg Limits and Particle Size Analysis) were utilized to verify existing soil types (verification of visual inspection). The results of the tests were used to properly classify each soil sample in accordance with the Unified Soil Classification System (USCS) as detailed in ASTM D2487 (TxDOT Tex-142-E). The results of the testing are provided on the boring logs in Appendix B. A summary of the results is provided in the previous Table 3.

Boring No.	Upper Soil Layer (Depths – 0 to 5 ft)			USCS Class
	LL	PI	-200	
B-01	32	19	42	SC
B-02	29	16	51	CL

**Table 3 – Subgrade Index Testing & Soil Classification (Upper Soils)**

In terms of usability of the existing soils for Access Drive / Facility Floor subgrade, the soils do generally meet the recommended PI of 10 or greater as referenced from the National Lime Association and PI of 12 or greater as referenced from the US Army Corps of Engineers (USACOE) for recommendation of lime stabilization.

### Subgrade Analysis (Pavement – Access Drive)

The existing subgrade index properties (plasticity index and grain size) were used to correlate the Modulus of Subgrade Reaction (k) and California Bearing Ratio (CBR) values of the subgrade. These values were then applied to the corresponding design procedures, according to the applicable Army Corps of Engineers manuals to determine the recommended minimum pavement thickness for flexible pavement designs. A subgrade k value of **200 pci** and CBR value of **10** was utilized in the pavement designs.

### Pavement Section Recommendations

After completing the pavement designs and considering Client requested gravel / caliche design only, L&G has provided the following recommendations within Table 4 for pavement thickness:

<b>Materials</b>	<b>Flexible Pavement Design Recommendation (Parking Lot)</b>
Flexible Base Material (Crushed Limestone or Caliche)	<b>8.0 in.</b>
Compacted Subgrade	<b>6.0 in.</b>

**Table 4 – Flexible Pavement Recommendation**

### Pavement Material Specification Recommendations

#### **Flexible Base Material**

Flexible base material shall be comprised of either crushed limestone or caliche base material. The crushed limestone material shall meet the requirements of TxDOT 2014 Specification Item 247 Type A, Grade 1 as noted in the “General Construction Considerations – Select Fill & Structural Fill Recommendations” section of this report. The caliche base material shall meet the requirements of TxDOT 2014 Specification Item 247 Type E, Grade 4 as approved by the engineer. Caliche base shall conform to the gradation and properties requirements noted in the “General Construction Considerations – Select Fill & Structural Fill Recommendations” section of this report before lime or admixtures are added. We recommend treating the caliche base material with two (2) percent lime or portland cement by weight. Lime and cement treatments shall be in compliance with all applicable sections of TxDOT Item 260 and 275 specifications.

- Additional Recommendations: Although a gravel / caliche design has been requested we offer the following additional recommendations for consideration. In order to ensure enhanced sealing of the base layer we also recommend a Prime Coat be applied immediately atop the base (such as MC-30) in accordance with TxDOT Item 310 specification as well as a One to Two Course Surface Treatment in accordance with TxDOT Item 316 specification. For this surface treatment, we recommend that selection of asphalt cement (or emulsified asphalt) and aggregate be based on the season of application and type of application.

### **Compacted Subgrade**

The existing subgrade layer beneath the upper layer (caliche/limestone) shall be compacted and moisture conditioned to a minimum 95 percent of the maximum dry density as determined by ASTM D698 or Tex-114-E (and tested in the field in accordance and compliance with ASTM 6938 or Tex-115-E).

## **GENERAL CONSTRUCTION CONSIDERATIONS**

### **Deep Foundation Recommendations (Drilled Shafts)**

**L&G** recommends all Drilled Shaft construction be in accordance with the requirements of TxDOT 2014 'Standard Specifications for Construction and Maintenance of Highways, Streets and Bridges', Item 416 – Drilled Shaft Foundations. Client should be advised that soils drilled shaft excavations may present the need for special excavation methods including the use of casing, slurry or both casing and slurry simultaneously to maintain stable excavations. Overall, the Contractor shall utilize an excavation method that is suitable to field conditions and that will result in a stable excavation. **L&G** further recommends that prior to construction a Drilling Construction Plan/Procedure be provided by the Contractor (to to the Engineer of Record) to ensure adequate planning and procedures based on site soil conditions. In terms of concrete, we recommend special attention be made to minimum/maximum slump of concrete required for drilled shafts (and requirements of slump retention). If differing site conditions (unanticipated or unusual strata) are encountered during construction, **L&G** shall be contacted to provide review and possible re-analysis if so required.

### **Site Grading Recommendations**

Site grading plans can result in changes in almost all aspects of foundation recommendations. We have prepared the foundation recommendations based on the existing ground surface and the stratigraphic conditions encountered at the time of our study. We recommend gradual slopes away from any foundations at structure locations to assist with site drainage, ponding, and any potential shrink/swell issues. We recommend the use of 3:1 slopes (or flatter) for general site grading.

### **Site Drainage Recommendations**

Drainage is one of the most important aspects to be addressed to ensure the successful performance of any foundation. Positive surface drainage should be implemented prior to, during and maintained after construction to prevent water ponding at or adjacent to the proposed facilities. We advise that construction drainage programs be implemented to assist with standing waters from precipitation, general surface runoff or other moisture intrusion. It is recommended that the site design include site drainage features to channel runoff away from the proposed site location and most importantly away from all foundations.

### **Site Preparation Recommendations**

The proposed site areas and all areas used to support foundation construction should be cleared and grubbed of all vegetation, organic topsoil and other miscellaneous debris up to a minimum of two (2) feet beyond the proposed site perimeters. This shall include the removal of all trees,

brush, roots, weeds, or other organic debris that will interfere with construction. After clearing, the contractor should follow the earthwork procedures outlined in the 'Foundation Recommendations' section of this report. Any soft and/or compressible soft spots noted during compaction activities shall be over-excavated and replaced with Select Fill. All placements of Select Fill and Structural Fill shall be in accordance with the "General Construction Considerations – Select Fill & Structural Fill Recommendations" section of this report. Any excavation/backfill activities should be observed by L&G representatives to document subgrade preparation.

### Embankment Recommendations

L&G recommends that Embankment Fill Sections utilized on this project be constructed in accordance with the requirements of TxDOT 2014 'Standard Specifications for Construction and Maintenance of Highways, Streets and Bridges', Item 132 – Embankment. Furthermore, L&G recommends the following controls be followed in accordance with TxDOT Pharr District Master General Notes:

- 'Embankment (DENS CONT) shall be Type C with a max. PI of 40. Material used as embankment material in the top two feet below the bottom of Flexible Base shall meet the following requirements based on preliminary tests and such other tests found necessary by the Engineer.
  - The material shall be such as to produce a well-bonded embankment and shall have a minimum PI of 8 and a maximum PI of 30.'

Compaction method is recommended for Embankment Fill Sections and shall be Density Controlled in accordance with the requirements of TxDOT 2014 'Standard Specifications', Item 132 – Embankment.

### Select Fill & Structural Fill Recommendations

Materials used for Select Fill (General Site Grading) shall meet the following requirements:

1. Soils classified according to the Unified Soils Classification System as SM, SC, GM, GC, CL, ML and combinations of these soils. These soils shall be free of organic material, topsoil, debris, or other deleterious material that cannot be properly compacted. In addition to the USCS classification, select materials shall have a **liquid limit of less than 40 and a plasticity index between 8 and 20**.
2. Soils classified as CH, MH, OH, OL and PT, under the USCS are not considered suitable for use as select fill materials at this site.
3. L&G recommends additional quality control of all 'General Site Fill' materials as they are placed and compacted to ensure that they meet the requirements specified.

**Select Fill** shall be placed in lifts not to exceed 8 inches loose (6 inches compacted) and compacted to a minimum 95 percent of the maximum dry density as determined in accordance with ASTM D698. The water content of the fill shall be maintained within the range of optimum moisture to three (3) percentage points above the optimum moisture content until the fill is permanently covered. The fill should be properly compacted in accordance with these recommendations and tested for compaction as specified.

Materials used for **Structural Fill** shall meet the following requirements:

1. Soils classified as Base Material meeting the requirements of TxDOT 2014 Specification Item 247 Type E, Grade 4 - Caliche (see Table 7 for specifications and req.) or Item 247 Type A, Grade 1 - Limestone (see Table 8 for specifications and req.).
2. L&G recommends additional quality control of all Structural Fill materials as they are placed and compacted to ensure that they meet the requirements specified.

**Structural Fill** shall be compacted to a minimum 98 percent of the maximum dry density as determined by the ASTM D698 at moisture contents ranging between minus two (-2) and plus two (+2) percentage points of the optimum moisture content. Structural Fill shall be placed in loose lifts not to exceed 8 inches (6 inches compacted). The fill should be properly compacted in accordance with these recommendations and tested for compaction as specified.

Retained on Square Sieve	Percent Retained
2"	0
1/2"	20-60
No. 4	40-75
No. 40	70-90
Plasticity Index, max	15
Wet Ball PI, max	15
Wet Ball Mill, % max	50

**Table 7 – Structural Fill - Type E Grade 4 Specifications**

Retained on Square Sieve	Percent Retained
2-1/2"	0
1-3/4"	0-10
7/8"	10-35
3/8"	30-65
No. 4	45-75
No. 40	65-90
Liquid Limit, % max	40
Plasticity Index, % max	10
Wet Ball Mill, % max	40

**Table 8 – Structural Fill - Type A Grade 1 Specifications**

### **Excavation and Trenching Recommendations**

If trenches or shallow excavations are to extend to or below a depth of five (5) feet, the Contractor or persons performing the trenching or shallow excavations should adhere to the current Occupational Health and Safety Administration (OSHA) guidelines on trench excavation safety and protection measures. Other industry standards may be applicable. If proposed trenching is to require excavation protection, **L&G** recommends protection be provided in accordance with the requirements of TxDOT 2014 'Standard Specifications for Construction and Maintenance of Highways, Streets and Bridges', Item 402 – Trench Excavation Protection and/or Item 403 – Temporary Special Shoring.

### **Miscellaneous Pavement Recommendations**

Adequate perimeter drainage is essential for long-term performance of the pavement structure. Infiltration of surface water from unpaved areas surrounding the pavement should be minimized. Base materials under curb and gutters should be compacted to the same requirements as other areas. If curbs or curb/gutters are used, it is recommended that these curb and gutters be extended through the base a minimum of 3 inches into the subgrade. An adequate seal should be provided at all base-asphalt interfaces. A maintenance plan is recommended for the long-term performance of paved areas. Asphaltic pavements have a tendency to strip and become oxidized with exposure to the elements. Thus cracks may become present in the pavement. It is recommended that a maintenance schedule of biannual crack sealing, fog seals and overlays every five to ten years be used over the life of the pavement.

## REFERENCES

1. Jacobs, Jerry L., 1981, "Soil Survey of Hidalgo County, Texas", Washington, D.C.
2. Bureau of Economic Geology, 1976, "Geologic Atlas of Texas, McAllen-Brownsville Datasheet", Austin, TX.
3. TxDOT, 2014, "Standard Specification for the Construction of Highways, Streets, and Bridges", Austin, TX.
4. TxDOT, 2005-Current, "100-E, Soils & Aggregates Test Procedures", Austin, TX.
5. American Society of Testing Materials, Volume 04.08, Soil and Rock (I): D420- D5779 (Up to Date).
6. TxDOT, 2000, 2006, 2012 "Geotechnical Manual", Austin, TX.
7. United Facilities Criteria (UFC), "Soils & Geology Procedures for Foundation Design of Building and Other Structures", UFC 3-220-03FA, (January 2004).
8. United States Army Corps of Engineers, "Flexible Pavements for Roads, Streets, Walks and Open Storage Areas", EM 1110-3-131

**APPENDIX A – FIGURES**



US 281

Hidalgo County

Project Location

Edinburg

FM 162

Washington

Adams

1st



Lincoln

### Figure 1

Hidalgo County Sheriff's Office  
Bus Barn

### Location Map

### Legend

-  Project Location
-  State Highway
-  Farm-to-Market County Road



1,000  
Feet

1 inch = 1,000 feet

 **L&G Engineering**  
File No. E-4195



**Figure 2**  
 Hidalgo County Sheriff's Office  
 Bus Barn  
**Boring Location Map**

<b>Legend</b>	
	Boring Locate
<div style="display: flex; align-items: center; justify-content: center;"> <div style="width: 50px; height: 10px; border: 1px solid black; margin-right: 5px;"></div> <span>100 Feet</span> </div> <p>1 inch = 100 feet</p>	
<div style="border: 1px solid black; padding: 5px; display: inline-block;">  <b>L&amp;G Engineering</b>  <small>Hwy 169, Ft. Bliss</small> </div>	

**APPENDIX B – BORING LOGS**



# L & G Engineering Laboratory

Construction Material Testing  
Geotechnical Engineering

L&G Engineering Laboratory  
2100 W. Expressway 83  
Mercedes TX 78570  
Telephone: 956-565-0760

## KEY TO SYMBOLS

CLIENT Hidalgo Co, Pct. 4

PROJECT NAME Sheriff's Office Bus Barn

PROJECT NUMBER GL19009

PROJECT LOCATION Hidalgo County

### LITHOLOGIC SYMBOLS (Unified Soil Classification System)



CH: USCS High Plasticity Clay



CL: USCS Low Plasticity Clay



CL-ML: USCS Low Plasticity Silty Clay



ML: USCS Silt



SC: USCS Clayey Sand



SC-SM: USCS Clayey Sand

### SAMPLER SYMBOLS



Standard Penetration Test

### WELL CONSTRUCTION SYMBOLS

### ABBREVIATIONS

LL - LIQUID LIMIT (%)  
 PI - PLASTIC INDEX (%)  
 W - MOISTURE CONTENT (%)  
 DD - DRY DENSITY (PCF)  
 NP - NON PLASTIC  
 -200 - PERCENT PASSING NO. 200 SIEVE  
 PP - POCKET PENETROMETER (TSF)

TV - TORVANE  
 PID - PHOTOIONIZATION DETECTOR  
 UC - UNCONFINED COMPRESSION  
 ppm - PARTS PER MILLION  
 Water Level at Time Drilling, or as Shown  
 Water Level at End of Drilling, or as Shown  
 Water Level After 24 Hours, or as Shown

KEY TO SYMBOLS - GINT STD US LAB.GDT - 10/25/19 16:33 - L:\GINT\PROJECTS\HIDALGO CO. PCT. 4 - SHERIFF'S OFFICE BUS BARN.GPJ

**L&G Engineering Laboratory**

Construction Material Testing  
Geotechnical Engineering

L&G Engineering Laboratory  
2100 W. Expressway 83  
Mercedes TX 78570  
Telephone: 956-565-0760

**BORING NUMBER B-01**

PAGE 1 OF 1

CLIENT Hidalgo Co. Pct. 4  
PROJECT NUMBER GL19009  
DATE STARTED 10/16/19 COMPLETED 10/16/19  
DRILLING CONTRACTOR L&G Engineering Laboratory  
DRILLING METHOD Solid Stem Auger  
LOGGED BY J. Sinclair CHECKED BY David A. Saenz, P.E.  
NOTES GPS 26°25'04.56" N, 98°07'37.02" W (Approx. Elev.)

PROJECT NAME Sheriff's Office Bus Barn  
PROJECT LOCATION Hidalgo County  
GROUND ELEVATION 89 ft HOLE SIZE 4 inches  
GROUND WATER LEVELS:  
∇ AT TIME OF DRILLING 19.00 ft / Elev 70.00 ft  
AT END OF DRILLING ---  
AFTER DRILLING ---

DEPTH (ft)	GRAPHIC LOG	MATERIAL DESCRIPTION	SAMPLE TYPE NUMBER	RECOVERY % (RQD)	BLOW COUNTS (N VALUE)	POCKET PEN. (tsf)	DRY UNIT WT. (pcf)	MOISTURE CONTENT (%)	ATTERBERG LIMITS			FINES CONTENT (%)
									LIQUID LIMIT	PLASTIC LIMIT	PLASTICITY INDEX	
0		(SC) Clayey Sand, Dk. Brown, Med. Dense, Dry	SPT 1		7-13-9 (22)			4				42
0		(CL) Sandy Lean Clay, Dk. Brown to Brown, Med. Stiff, Dry	SPT 2		5-5-3 (8)			5	32	13	19	
5			SPT 3		2-2-2 (4)			11				
5			SPT 4		2-3-5 (8)			11				63
5			SPT 5		3-4-5 (9)			12	28	15	13	
10												
15		(CL) Sandy Lean Clay, Brown, w/ Calcareous Nodules, Very Stiff, Dry	SPT 6		4-12-18 (30)			17	32	18	14	55
20		∇ (CL) Lean Clay, Brown, w/ Traces of Gravel (Sized 1/4 to 1/2 in. Diam., Shaped Sub-Angular), Moist to Wet	SPT 7		8-9-9 (18)			25	27	16	11	85
25			SPT 8		2-3-2 (5)			27	27	16	11	82
30		(ML) Sandy Silt, Tan, Stiff, Wet	SPT 9		3-4-6 (10)			29	NP	NP	NP	56
35		(CH) Fat Clay, Brown, Very Stiff, Wet	SPT 10		11-11-16 (27)			22	53	20	33	94

Bottom of borehole at 35.0 feet.

GEOTECH BH COLUMNS - GINT STD US LAB.GDT - 10/25/19 16:31 - L:\GINT\PROJECTS\HIDALGO CO. PCT. 4 - SHERIFF'S OFFICE BUS BARN.GPJ

# L & G Engineering Laboratory

Construction Material Testing  
Geotechnical Engineering

L&G Engineering Laboratory  
2100 W. Expressway 83  
Mercedes TX 78570  
Telephone: 956-565-0760

## BORING NUMBER B-02

PAGE 1 OF 1

CLIENT Hidalgo Co. Pct. 4 PROJECT NAME Sheriff's Office Bus Barn  
 PROJECT NUMBER GL19009 PROJECT LOCATION Hidalgo County  
 DATE STARTED 10/16/19 COMPLETED 10/16/19 GROUND ELEVATION 89 ft HOLE SIZE 4 inches  
 DRILLING CONTRACTOR L&G Engineering Laboratory GROUND WATER LEVELS:  
 DRILLING METHOD Solid Stem Auger  AT TIME OF DRILLING 17.00 ft / Elev 72.00 ft  
 LOGGED BY J. Sinclair CHECKED BY David A. Saenz, P.E. AT END OF DRILLING --  
 NOTES GPS 26°25'04.86" N, 98°07'35.94" W (Approx. Elev.) AFTER DRILLING --

DEPTH (ft)	GRAPHIC LOG	MATERIAL DESCRIPTION	SAMPLE TYPE NUMBER	RECOVERY % (RQD)	BLOW COUNTS (N VALUE)	POCKET PEN. (tsf)	DRY UNIT WT. (pcf)	MOISTURE CONTENT (%)	ATTERBERG LIMITS			FINES CONTENT (%)	
									LIQUID LIMIT	PLASTIC LIMIT	PLASTICITY INDEX		
0		(CL) Sandy Lean Clay, Dk. Brown to Brown, w/ Calcareous Nodules and Traces of Gravel (Sized Less Than 1/4 in., Shaped Sub-Rounded), Med. Stiff to Stiff, Dry	SPT 1		4-5-6 (11)			7	29	13	16	51	
2.5			SPT 2		6-5-7 (12)			6					
5			SPT 3		4-4-4 (8)			7					
7.5			SPT 4		3-4-5 (9)			13	29	14	15		
10			SPT 5		3-6-7 (13)			12					56
15			(SC) Clayey Sand, Brown, Loose, Dry to Moist	SPT 6		1-3-7 (10)			22	28	18	10	37
20			(CL-ML) Silty Clay w/ Sand, Brown, w/ Traces of Gravel (Sized Less Than 1/4 in., Shaped Sub-Rounded and Sub-Angular), Very Stiff, Moist to Wet	SPT 7		13-13-14 (27)			19	24	17	7	72
25			(SC-SM) Silty Clayey Sand, Brown to Tan, Med. Dense, Wet	SPT 8		3-3-8 (11)			24	NP	NP	NP	27
30				SPT 9		7-9-14 (23)			25	NP	NP	NP	29
35				SPT 10		16-20-24 (44)			27	NP	NP	NP	20

Bottom of borehole at 35.0 feet.

GEOTECH BH COLUMNS - GINT STD US LAB.GDT - 10/25/19 16:31 - L:\GINT\PROJECTS\HIDALGO CO. PCT. 4 - SHERIFF'S OFFICE BUS BARN.GPJ

**APPENDIX C – FOUNDATION CAPACITY CURVES**

# FOUNDATION CAPACITY

WinCore  
Version 3.1

County Hidalgo  
Highway HCSO Bus Barn  
Control

Hole B-01  
Structure  
Station  
Offset

District  
Date 10-16-2019  
Grnd. Elev. 89.00 ft  
GW Elev. 70.00 ft

18 inch Drilled Shaft

+89 Top Hole Elevation  
+86 Disregard Elevation

Disregard above hard strata disabled  
Pb: 2 Diameters Below Tip Checked  
TCP Capacity Values Used  
0.7 Soil Reduction Factor Used

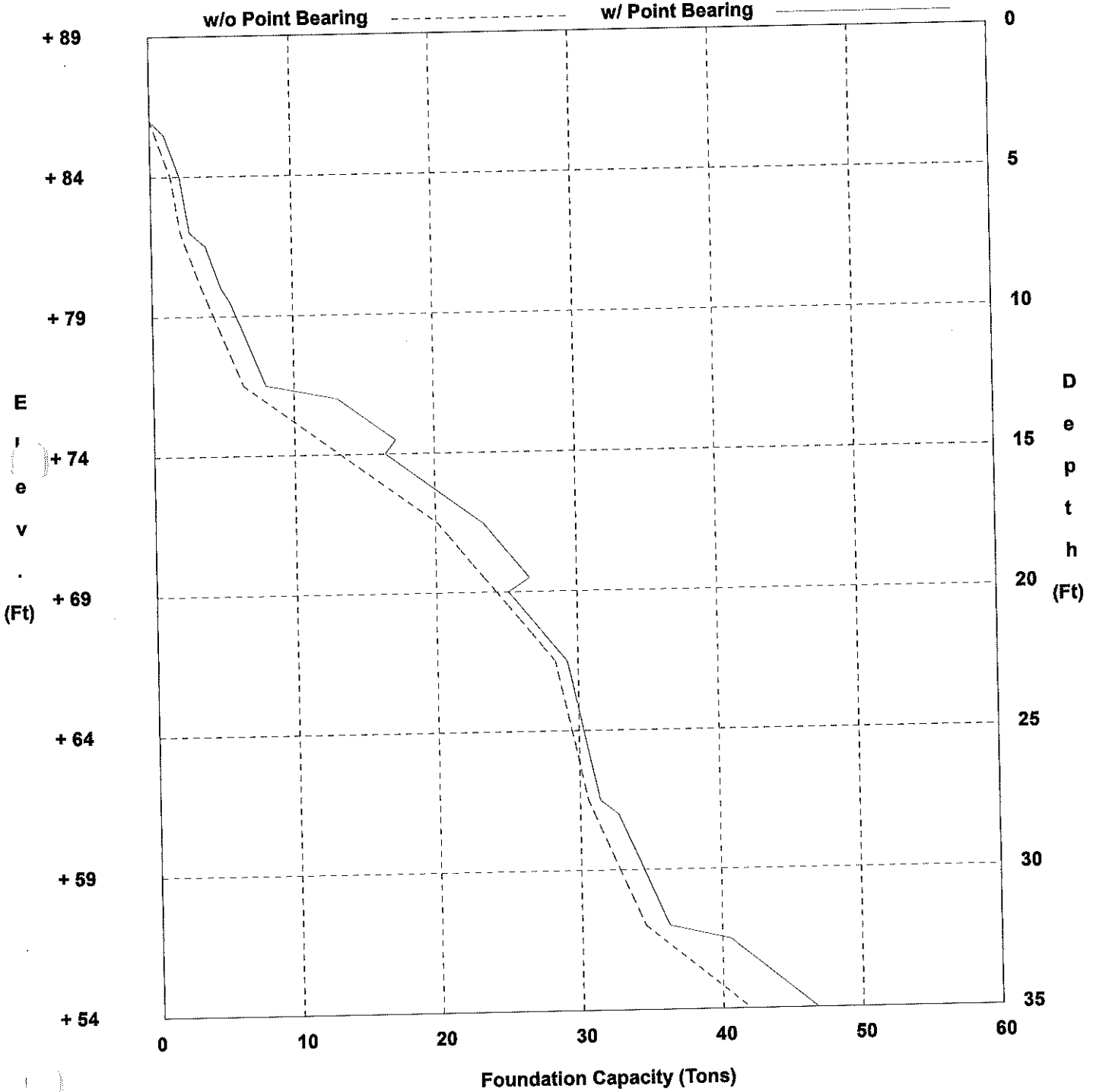

# FOUNDATION CAPACITY

WinCore  
Version 3.1

County Hidalgo  
Highway HCSO Bus Barn  
Control

Hole B-02  
Structure  
Station  
Offset

District  
Date 10-16-2019  
Grnd. Elev. 89.00 ft  
GW Elev. 72.00 ft

18 inch Drilled Shaft

+89 Top Hole Elevation  
+86 Disregard Elevation

Disregard above hard strata disabled  
Pb: 2 Diameters Below Tip Checked  
TCP Capacity Values Used  
0.7 Soil Reduction Factor Used

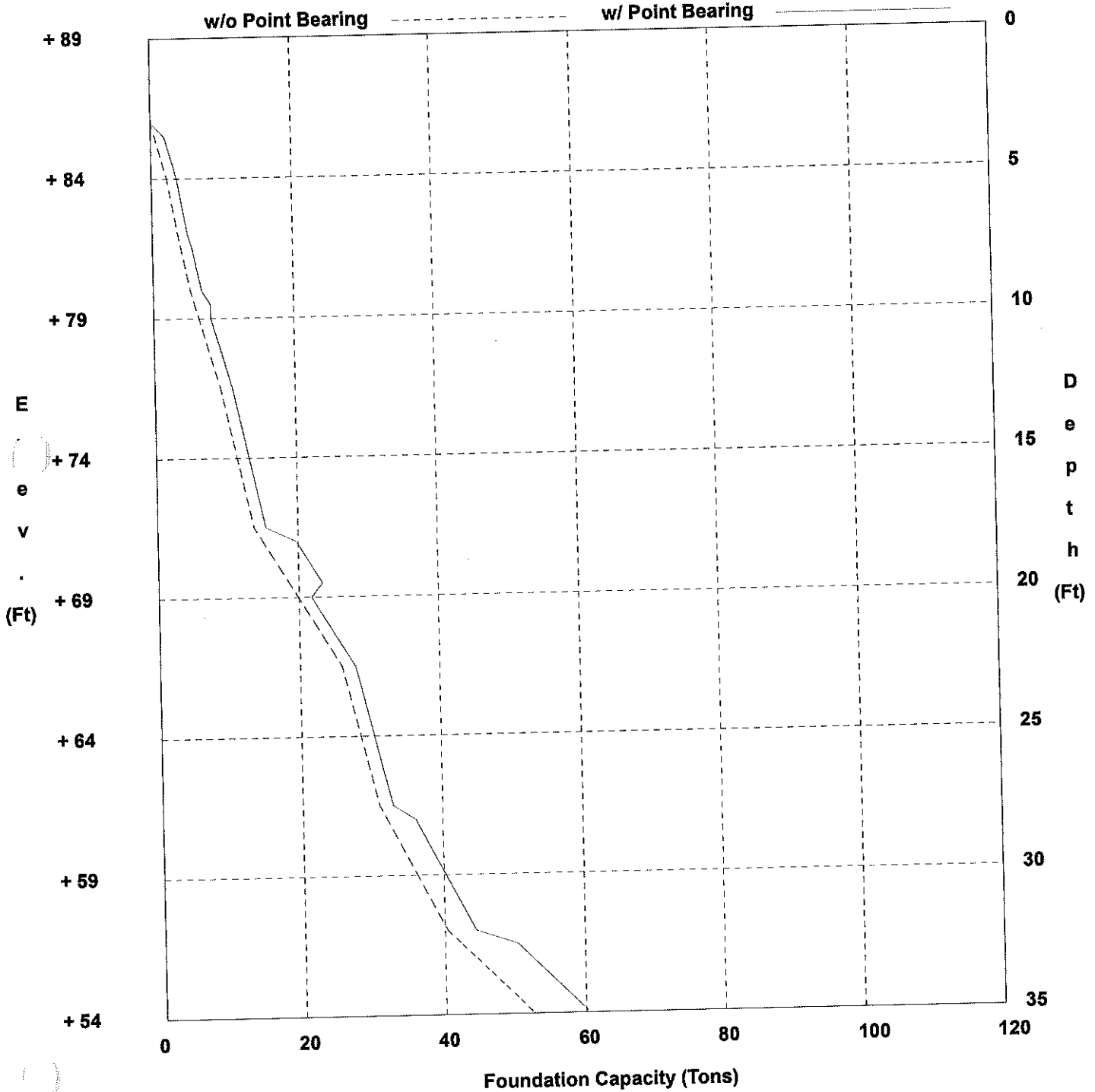

# FOUNDATION CAPACITY

WinCore  
Version 3.1

County Hidalgo  
Highway HCSO Bus Barn  
Control

Hole B-01  
Structure  
Station  
Offset

District  
Date 10-16-2019  
Grnd. Elev. 89.00 ft  
GW Elev. 70.00 ft

24 Inch Drilled Shaft

+89 Top Hole Elevation  
+86 Disregard Elevation

Disregard above hard strata disabled  
Pb: 2 Diameters Below Tip Checked  
TCP Capacity Values Used  
0.7 Soil Reduction Factor Used

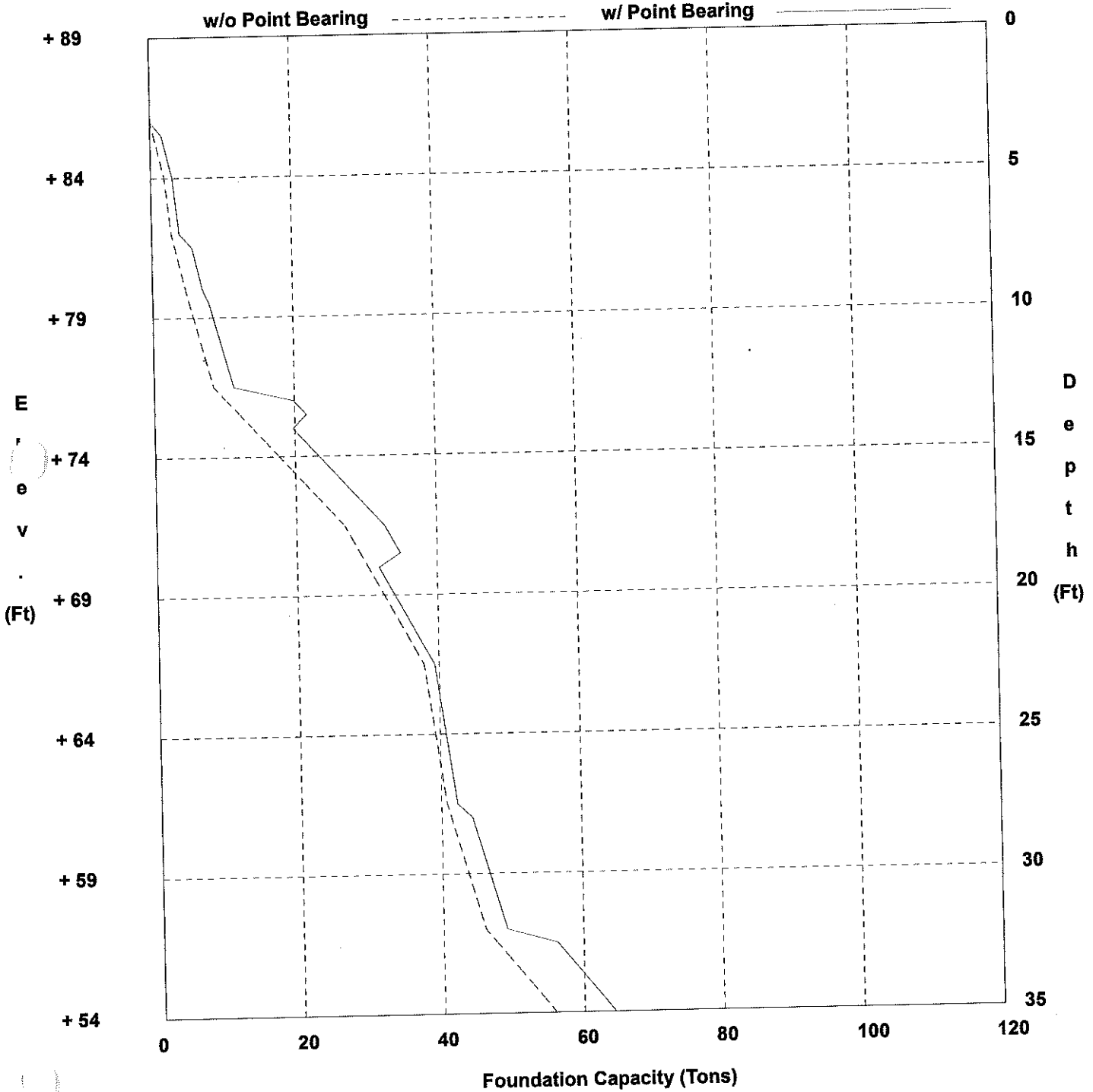

# FOUNDATION CAPACITY

WinCore  
Version 3.1

County Hidalgo  
Highway HCSO Bus Barn  
Control

Hole B-02  
Structure  
Station  
Offset

District  
Date 10-16-2019  
Grnd. Elev. 89.00 ft  
GW Elev. 72.00 ft

24 inch Drilled Shaft

+89 Top Hole Elevation  
+86 Disregard Elevation

Disregard above hard strata disabled  
Pb: 2 Diameters Below Tip Checked  
TCP Capacity Values Used  
0.7 Soil Reduction Factor Used

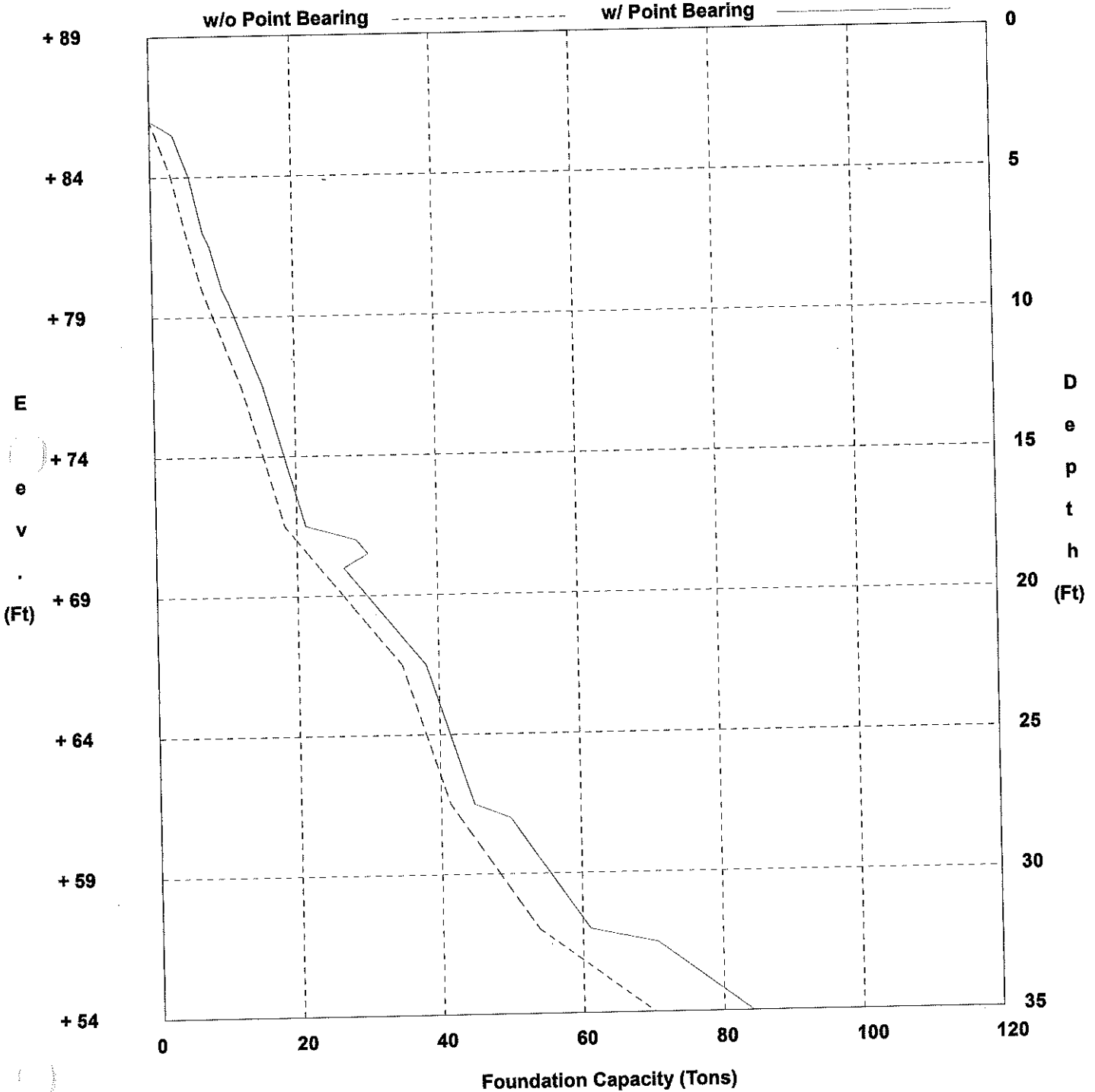

# FOUNDATION CAPACITY

WinCore  
Version 3.1

County Hidalgo  
Highway HCSO Bus Barn  
Control

Hole B-01  
Structure  
Station  
Offset

District  
Date 10-16-2019  
Grnd. Elev. 89.00 ft  
GW Elev. 70.00 ft

30 Inch Drilled Shaft

+89 Top Hole Elevation  
+86 Disregard Elevation

Disregard above hard strata disabled  
Pb: 2 Diameters Below Tip Checked  
TCP Capacity Values Used  
0.7 Soil Reduction Factor Used

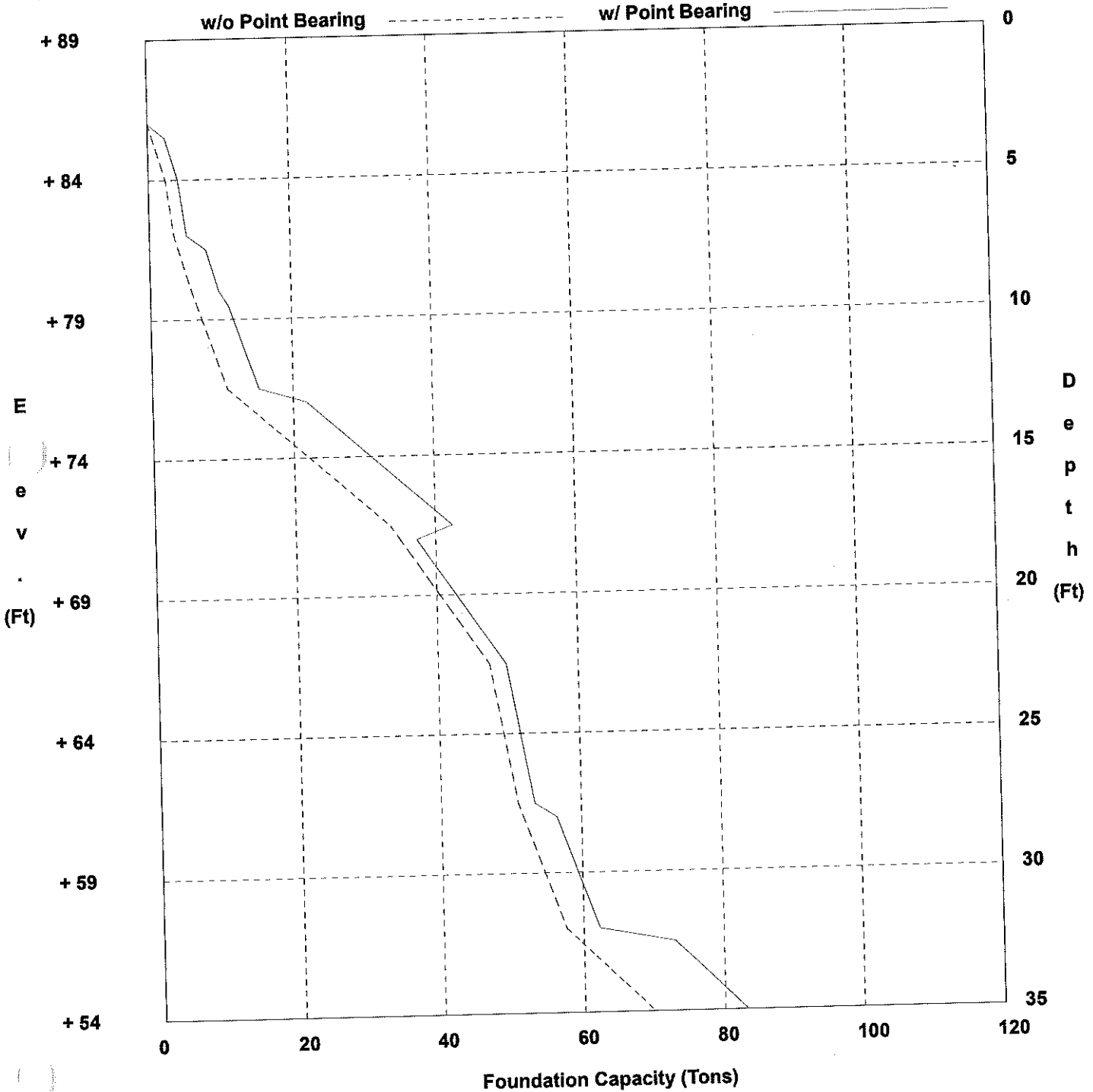

# FOUNDATION CAPACITY

WinCore  
Version 3.1

County Hidalgo  
Highway HCSO Bus Barn  
Control

Hole B-02  
Structure  
Station  
Offset

District  
Date 10-16-2019  
Grnd. Elev. 89.00 ft  
GW Elev. 72.00 ft

30 inch Drilled Shaft

+89 Top Hole Elevation  
+86 Disregard Elevation

Disregard above hard strata disabled  
Pb: 2 Diameters Below Tip Checked  
TCP Capacity Values Used  
0.7 Soil Reduction Factor Used

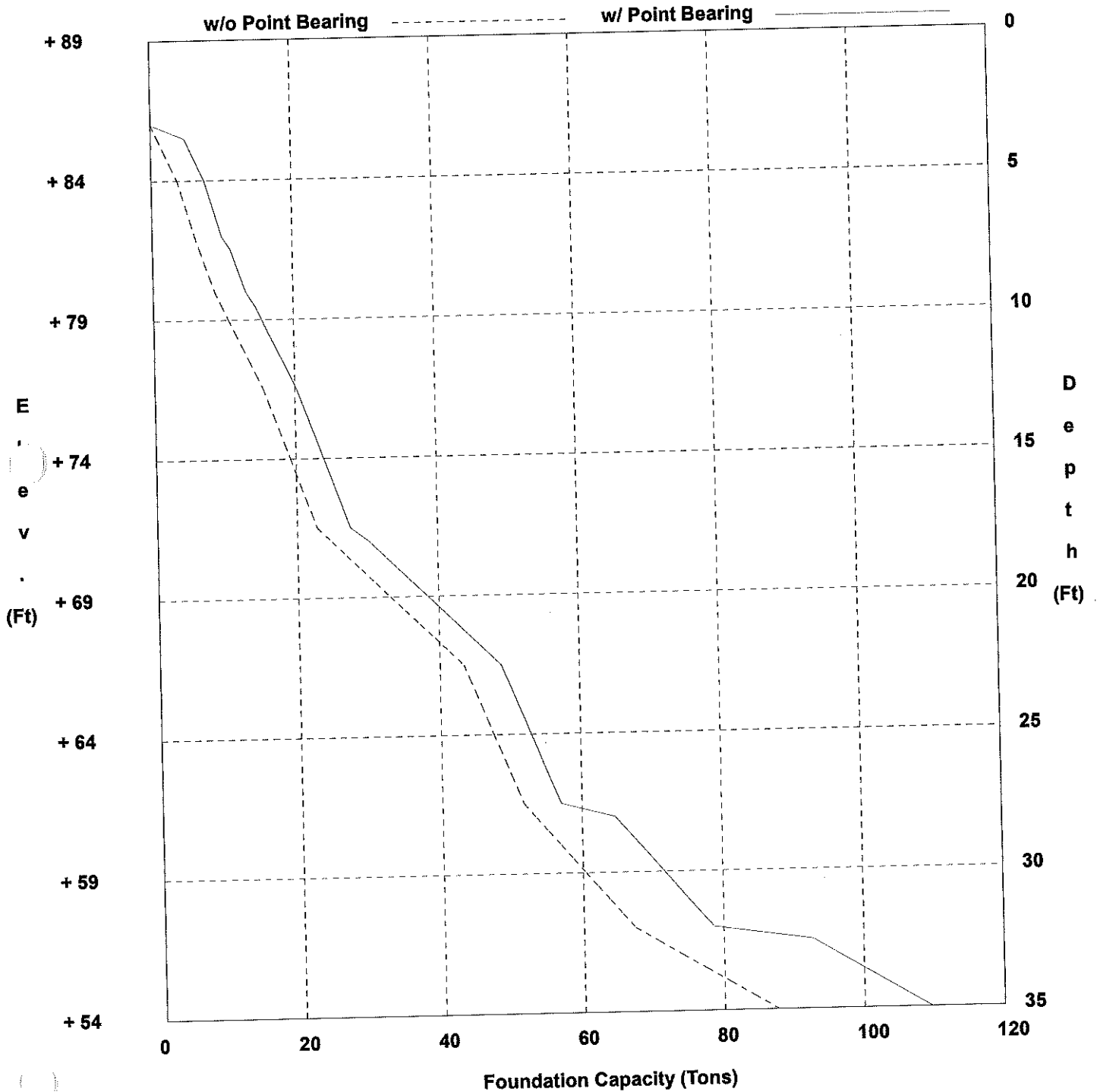

# FOUNDATION CAPACITY

WinCore  
Version 3.1

County Hidalgo  
Highway HCSO Bus Barn  
Control

Hole B-01  
Structure  
Station  
Offset

District  
Date 10-16-2019  
Grnd. Elev. 89.00 ft  
GW Elev. 70.00 ft

36 inch Drilled Shaft

+89 Top Hole Elevation  
+86 Disregard Elevation

Disregard above hard strata disabled  
Pb: 2 Diameters Below Tip Checked  
TCP Capacity Values Used  
0.7 Soil Reduction Factor Used

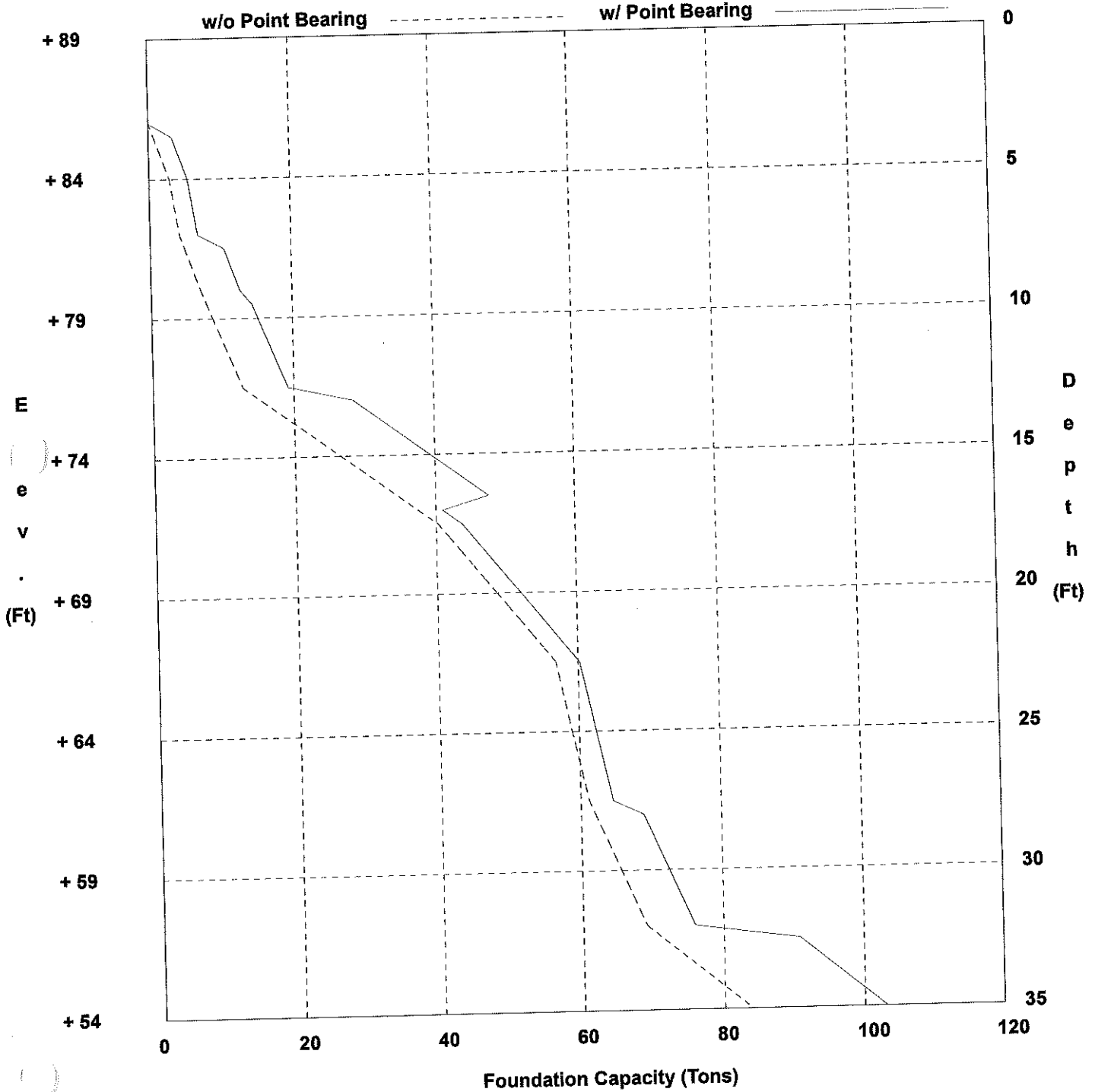

# FOUNDATION CAPACITY

WinCore  
Version 3.1

County Hidalgo  
Highway HCSO Bus Barn  
Control

Hole B-02  
Structure  
Station  
Offset

District  
Date 10-16-2019  
Grnd. Elev. 89.00 ft  
GW Elev. 72.00 ft

36 inch Drilled Shaft

+89 Top Hole Elevation  
+86 Disregard Elevation

Disregard above hard strata disabled  
Pb: 2 Diameters Below Tip Checked  
TCP Capacity Values Used  
0.7 Soil Reduction Factor Used

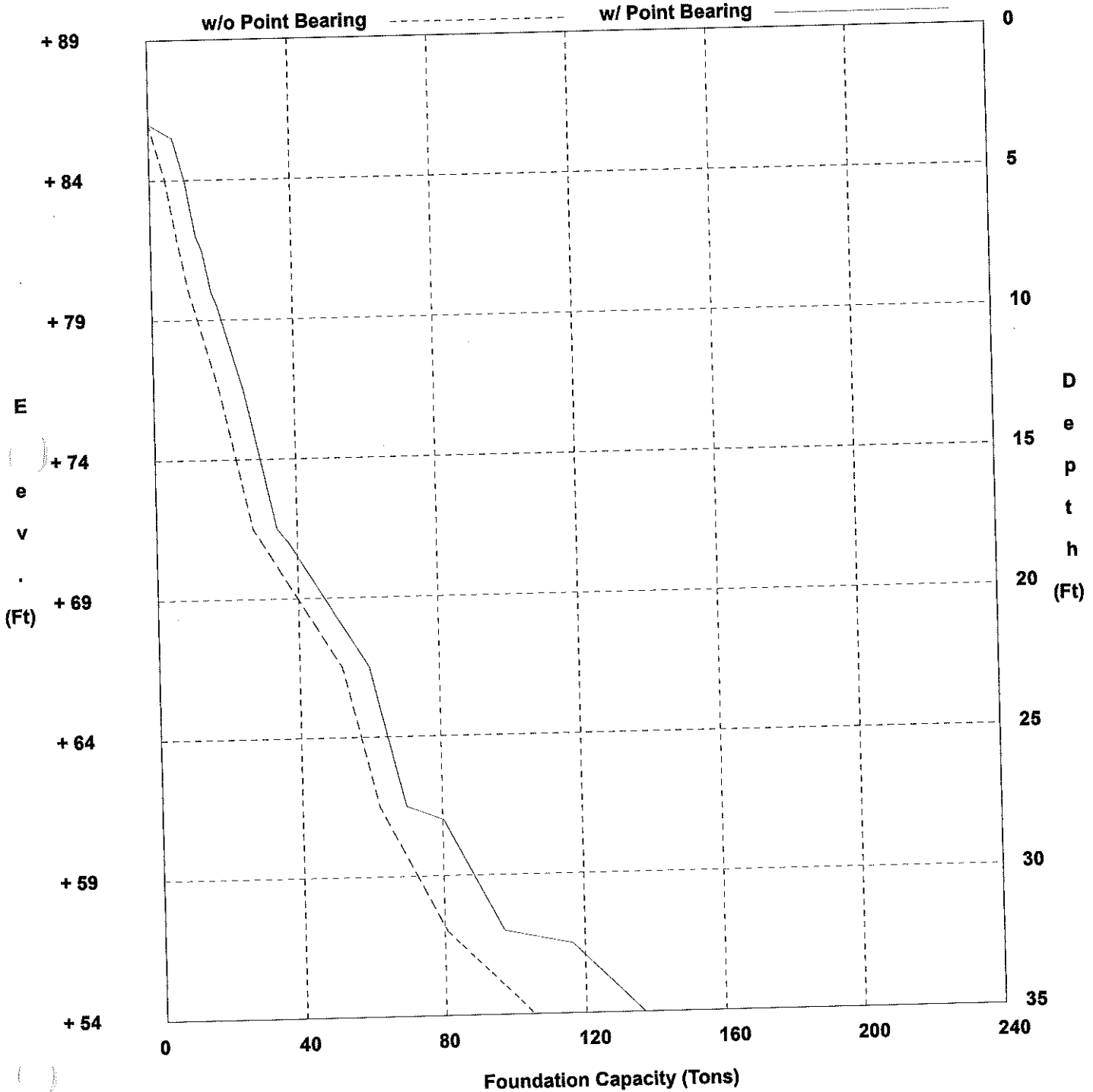

**APPENDIX D – INFO PROVIDED BY CLIENT (REFERENCE)**



Bid No: 2019-267-04-15-ABV

Contract Specialist II: Alexandra Vela

Tel. No.: (956) 318-2626 Ext. 4865

# REQUEST FOR BIDS

## HIDALGO COUNTY

**“Construction of Bus Barn for Hidalgo County Sheriff’s Office”**

**RFB No: 2019-267-04-15-ABV**

**Acceptance Due Date: April 15, 2020**

Martha L. Salazar, CPPB, Purchasing Agent  
Hidalgo County Purchasing Department

**Project Contract Specialist Contact Information:**

Alexandra Vela, Contract Specialist II  
Hidalgo County Purchasing Department  
Physical Address: 2802 S. Business Hwy. 281 - Administration Building  
Mailing/Postal Address: 2812 S. Business Hwy. 281  
Edinburg, Texas 78539  
(956) 318-2626 Ext. 4865  
[Alexandra.vela@co.hidalgo.tx.us](mailto:Alexandra.vela@co.hidalgo.tx.us)





Hidalgo County Purchasing Office  
2812 S. Business Highway 281  
New Administration Building  
Edinburg, Texas 78539  
(956) 318-2626/ Fax: (956) 292-7612

March 25, 2020

The Monitor  
1400 East Nolana  
McAllen, Texas 78504

**Re: Hidalgo County –“Construction of Bus Barn for Hidalgo County Sheriff’s Office”**  
**Bid Opening Date: April 15th, 2020**  
**RFB: 2019-267-04-15**

Gentlemen:

Please publish twice the enclosed advertisement under the legal ad section of your newspaper. The first publication should run on **SATURDAY, March 28, 2020** and the second on **SATURDAY, April 04, 2020.**

After these publications, please submit to this office a publisher’s affidavit for our records. The billing statement should be mailed to:

**Hidalgo County Sheriff’s Office**  
**701 E. El Cibolo Rd.**  
**Edinburg, Texas 78542**  
**PO 809541**

Thank you for your assistance in this matter.

Sincerely,

**Martha L. Salazar, CPPB**  
Hidalgo County Purchasing Agent

MLS/abv

# REVISED REQUEST FOR BIDS

TO SUPPLY HIDALGO COUNTY with sealed bids on: "Construction of Bus Barn for Hidalgo County Sheriff's Office"

A BIDDER'S BOND from a reliable surety company licensed to operate in the State of Texas or certified Cashier's Check, payable without recourse to the County of Hidalgo, for the amount of not less than 5% of the total bid shall accompany the bid as guaranty that, if awarded the contract, the bidder will enter into a contract with the County of Hidalgo. Payment and Performance Bonds shall be executed except in the event into a single payment contract with the County of Hidalgo in lieu of a Performance Bond. In the event the total amount bid is \$25,000 or less, the successful contract has the option to enter into a single payment contract with the County of Hidalgo in lieu of a Payment and Performance Bond.

**Bid Packets** may be obtained by calling the Hidalgo County Purchasing Department at Phone No. (956) 318-2626 or by email request at [alexandra.vela@co.hidalgo.tx.us](mailto:alexandra.vela@co.hidalgo.tx.us).

**PRE-BID CONFERENCE** is scheduled for Tuesday, April 08, 2020 at 3:30 P.M. at **HIDALGO COUNTY NEW ADMINISTRATION BUILDING-PURCHASING DEPARTMENT 2812 S Business Hwy 281, EDINBURG, TEXAS 78539.**

**UPON SUBMITTING SEALED BID**, bidders are required to properly identify (handwritten, typed or printed) sealed envelope and/or packet as follows: Bidder's name and address on the upper left hand corner of the sealed envelope and/or package and Bid No.: 2019-267-04-15-ABV-"Construction of Bus Barn for Hidalgo County Sheriff's Office" on the lower left hand corner of sealed envelope/and or packet. **OVERNIGHT MAIL MUST ALSO BE PROPERLY LABELED ON THE OUTSIDE OF EXPRESS ENVELOPE OR PACKAGE.**

The sealed bid must contain one (1) original, one (1) copy, and two (2) (CD'S/USB in PDF format) must be clearly identified and addressed for delivery to:

Martha L. Salazar, CPPB, Hidalgo County Purchasing Agent  
Hidalgo County Purchasing Department

**US Postal Mail/Courier Address**  
Hidalgo County New Administration Building  
2812 S. Business Hwy 281  
Edinburg, Texas 78539

**Physical Location:**  
Hidalgo County New Administration Building  
2802 S. Business Hwy. 281  
(Southeast of Canton Rd & Business 281)  
Edinburg, Texas 78539

Sealed bids will be accepted until **9:30 a.m. on Wednesday, April 15, 2020** at which time they will be opened in the Hidalgo County Purchasing Department Conference Room at **Physical Location: 2802 S. Business Hwy 281, Hidalgo County New Administration Building, Edinburg, Texas 78539.** NO FACSIMILES OR LATE ARRIVALS WILL BE ACCEPTED. ANY BID RECEIVED AFTER THAT TIME WILL NOT BE OPENED AND WILL BE RETURNED

Attention is called to the fact that not less than, the federally determined prevailing (**Davis-Bacon and Related Acts**) wage rate, as issued and contained in the contract documents, must be paid on this project. In addition, the successful bidder must ensure that employees and applicants for employment are not discriminated against because of race, color, religion, sex, age, disability or national origin (if applicable.)

**BIDS MAY BE HELD** by the County of Hidalgo for a period not to exceed ninety (90) days from the date of the opening of bids for the purpose of reviewing the bids and investigating the qualifications of bidders, prior to awarding of the contract.

**THE COUNTY** reserves the right to refuse and reject any/all bids and to waive any/all formalities or technicalities, or to accept the bids considered the best and most advantageous to the County.

Typed written bidding RFI's shall be e-mailed to [alexandra.vela@co.hidalgo.tx.us](mailto:alexandra.vela@co.hidalgo.tx.us). RFI's **will not be answered by phone.** NO HAND WRITTEN RFI'S will be processed/answered. All inquiries shall be forwarded by **5:00 PM Monday April 08, 2020.** Responses to said inquiries will be sent to all applicants via facsimile by no later than **5:00 p.m. Wednesday April 10, 2020.** Inquiries beyond this date will not be responded to. Contact project architect's office for copies of Addenda. All bidders who paid a deposit will be required to return Addenda as part of the Construction Documents in order to receive full deposit or refund.

**BY ORDER OF THE COMMISSIONERS COURT OF HIDALGO COUNTY, TEXAS** on this the 24th of March 2020.

MARTHA L. SALAZAR, CPPB  
HIDALGO COUNTY PURCHASING AGENT

**REPORT ROAD HAZARDS @ 1-866-HCR-SAFE OR 1-866-427-7233**



2802 S. Bus. Hwy 281  
Edinburg, Texas 78539  
Phone: (956) 318-2626  
Fax: (956) 318-2629  
[www.co.hidalgo.tx.us/purchasing](http://www.co.hidalgo.tx.us/purchasing)

---

March 30, 2020

---

Participant's name

---

Address

---

City

---

State, Zip Code

Re: **HIDALGO COUNTY**

Request for Bids- **"Construction of Bus Barn for Hidalgo County Sheriff's Office"**

**RFB No: 2019-267-04-15-ABV**

Dear Respondents:

Enclosed please find a Request for Bid (RFB) packet for your consideration. Modifications and new requirements have been added and implemented. Carefully read and review all instructions, requirements and specifications.

Hidalgo County Purchasing Department welcomes and appreciates your participation in the Request for Qualifications process.

If any further assistance is required, please do not hesitate to call the Purchasing Department at 956-318-2626 ext. 4865.

Sincerely,

Martha L. Salazar, CPPB

Hidalgo County Purchasing Agent

MLS/abv

Enclosures



2802 S. Bus. Hwy 281  
Edinburg, Texas 78539  
Phone: (956) 318-2626  
Fax: (956) 318-2629  
[www.co.hidalgo.tx.us/purchasing](http://www.co.hidalgo.tx.us/purchasing)

## HIDALGO COUNTY TABLE OF CONTENTS

RFB No: 2019-267-04-15-ABV

### “Construction of Bus Barn for Hidalgo County Sheriff’s Office”

Item	Description	Page Number
1.	Request for Bids Letter	1
2.	Request for Bids Table of Contents	2
3.	Request for Bids, Legal Notice	12
4.	Information for Bidders	5
5.	Bid Bond	2
6.	Specifications	24
7.	Bid Form	3
8.	Bid Sheet	1
9.	Statement of Credentials	6
10.	Construction Contract	2
11.	Payment Bond & Performance Bond	7
12.	General Notes & Standard Specifications	49
13.	Exhibit C, Insurance	5
14.	Exhibit D, (CIQ) Conflict of Interest Questionnaire	3
15.	Exhibit E, Vendor/Bidder Application and W-9 Form(s)	9
16.	Exhibit F, Certification Regarding Debarment	2

17.	Exhibit G, Title VI Appendices "A" thru "E"	6
18.	Exhibit H, Required Contract Clauses for Contracts Under Federal Award (if applicable)	15
19.	Exhibit I, FHWA 1273	13
20.	Exhibit J, Proposer's Affidavit	1
21.	RFB Submittal Check List	1
22.	Draft Contract	2

The above-mentioned items shall be found in the Request for Bids (RFB) packet that is attached herewith. Should you find that any of the items are not attached in its entirety please contact Purchasing by calling (956) 318-2626, advise of missing documentation, and Purchasing will forward information either through facsimile or by U.S. Mail. Thank you.

Bid No: 2019-267-04-15-ABV

Contract Specialist II: Alexandra Vela

Tel. No.: (956) 318-2626 Ext. 4865

# REQUEST FOR BIDS

## HIDALGO COUNTY

**“Construction of Bus Barn for Hidalgo County Sheriff’s Office”**  
**RFB No: 2019-267-04-15-ABV**

**Acceptance Due Date: April 15, 2020**

Martha L. Salazar, CPPB, Purchasing Agent  
Hidalgo County Purchasing Department

**Project Contract Specialist Contact Information:**

Alexandra Vela, Contract Specialist II  
Hidalgo County Purchasing Department  
Physical Address: 2802 S. Business Hwy. 281 - Administration Building  
Mailing/Postal Address: 2812 S. Business Hwy. 281  
Edinburg, Texas 78539  
(956) 318-2626 Ext. 4865  
[Alexandra.vela@co.hidalgo.tx.us](mailto:Alexandra.vela@co.hidalgo.tx.us)



1. Bids will be received for "**Construction of Bus Barn for Hidalgo County Sheriff's Office**", in accordance with the requirements attached hereto as Exhibit "A". The bid should address all requirements set forth. Bidders (may also be referred to as respondent, contractor or vendor) may suggest substitutions of features which they feel would be in the best interest of Hidalgo County ("County"), however, a strong rationale must be presented for any deviation from the requirements. Hidalgo County reserves the right to reject the deviation and its effect on the overall bid.
2. **One (1) original** (pages *one-sided* – clearly marked **ORIGINAL**), **one (1) copy** of all bids and **two (2) CD/USB in PDF format** are required with the bidder's name and address clearly typed/printed on upper left-hand corner and the proper notation clearly typed/printed on the lower left-hand corner of the envelope and/or package, **RFB: 2019-267-04-15-ABV Hidalgo County "Construction of Bus Barn for Hidalgo County Sheriff's Office"** and in County's Purchasing Department, Physical Location: 2802 S. Business Hwy. 281 Postal/ Mailing: 2812 S. Business Hwy. 281 Administration Building, Edinburg, Texas, **ON OR BEFORE 9:30 A.M., WEDNESDAY, April 15, 2020.**

**NO FACSIMILES OR LATE ARRIVALS WILL BE ACCEPTED. ANY BID RECEIVED AFTER THAT TIME WILL NOT BE OPENED AND WILL BE RETURNED. OVERNIGHT MAIL MUST ALSO BE PROPERLY LABELED ON THE OUTSIDE OF EXPRESS ENVELOPE AND/OR PACKAGE IN REFERENCE TO SEALED BID.**

Hidalgo County reserves the right to refuse and reject any/all bids and to waive any/all formalities or technicalities or to accept the bid considered the best and most advantageous to Hidalgo County.

Additionally, all forms listed below must be properly executed and included with your RFB:

1. Legal Notice Acknowledgement (See **page 12**);
  2. Insurance pages with Acknowledgment Forms (See **Exhibit "C"**);
  3. Form CIQ-Conflict of Interest Questionnaire (See **Exhibit "D"**);
  4. Vendor Bidder Application, W-9, & HUB/DBE (See **Exhibit "E"**);
  5. Certification Regarding Debarment (See **Exhibit "F"**);
  6. (*If applicable*) - Required Contract Clauses for Contracts Under Federal Award – 2 CFR 200, Appendix II & FEMA (See **Exhibit "H"**);
  7. Proposer's Affidavit (See **Exhibit "J"**); and
  8. SAMS.gov Registration Acknowledgement (See **Number 18** below).
3. Hidalgo County reserves the right to separate and accept or eliminate any item(s) listed under this bid that it deems necessary to accommodate budgetary and/or operational requirements. Hidalgo County also reserves the right to reject any or all bids submitted. Receipt of any bid shall under no circumstances obligate County to accept the lowest dollar bid. The award of this contract shall be made to the responsible bidder whose bid is determined to be the best bid, taking into consideration the relative importance of price and other factors as herein set forth.
  4. The Bidder shall not substitute items named in the bid without the express written consent of Hidalgo County. Failure of the delivered item to perform as specified or failure to meet the stated delivery schedule shall release Hidalgo County from all obligations to the contracting party with regard to the item(s) in question. In such an event, County may elect to award the contract to the next lowest responsible bidder or to reject all sealed bids and re-advertise.

**LEGAL NOTICE**

- Bidder is responsible for obtaining any information needed in order to respond to the RFB. For work to be performed at a County owned or operated location, each respondent shall, in its sole discretion, visit the job site before preparing the bid and thoroughly familiarize himself/herself with existing conditions. Respondent should take field dimensions and note all circumstances which affect the dollar amount.
6. Bidder should provide any and all relevant information necessary to establish Bids. Descriptive specifications are referenced in this document to indicate the general kind and quality of equipment desired by Hidalgo County. Due to various styles and models of equipment, respondents are required to include illustrations, specifications, explanation of warranties, and service data with their response including catalog numbers and any necessary references.
  7. No bid may be withdrawn within thirty (30) days from the scheduled time to open bids.
  8. Submitted Bid prices are to remain firm for a minimum of ninety (90) days after the RFB opening.
  9. Any interpretations, amendments, corrections or changes to this RFB document must be in a written addendum and signed by the County Judge or his designee. Addenda will be mailed to all who are known to have received a copy of the Request for Bids. Respondents shall acknowledge receipt of all addenda as a part of their Bids submittal.
  10. County reserves the right to accept or reject any or all Bids.
  11. Respondent is responsible for all costs of submitting its response to the RFB.
  12. The county is exempt from Federal Excise Tax, State Tax, and Local Tax. Do Not include tax in cost figure(s). If it is determined that tax was included in the cost figure(s) it will not be included in the tabulation of any awards. Tax exemption certificates will be furnished upon request.
  13. Funds for this procurement have been provided through the County budget for this fiscal year only. County, on an annual basis, has the right to reconsider a contract during the budget process for ensuing years if financial resources of County are insufficient to meet the liabilities of said contract. The award of a bid or contract hereunder will not be construed to create a debt of the County which is payable out of funds beyond the current fiscal year.
  14. Upon award and prior to execution of a contract, Sole Proprietorships are required to submit a copy of their social security cards to the Hidalgo County Auditor's Office in order to establish an account with the County. All awarded vendors must submit a completed W-9 and a copy of their Federal ID Number Certificate.
  15. **POST-AWARD DELIVERY INSTRUCTIONS (if applicable):**
    - Costs are to be net F.O.B., County Prepaid.
    - No deliveries accepted after 3:00 P.M., Monday-Friday (if applicable).
    - At least seventy-two (72) hours prior notice of delivery must (if applicable) be given to Martha L. Salazar, CPPB, Hidalgo County Purchasing Agent before delivery will be accepted.
    - If you need additional information call the office listed below:

Hidalgo County Purchasing Department  
 Martha L. Salazar, CPPB, Purchasing Agent  
 (956) 318-2626

**16. POST-AWARD PROJECT-SPECIFIC BILLING AND PAYMENT INSTRUCTIONS:**

- Invoices must include:
  - a) Name and address of successful respondent;
  - b) Name and address of receiving department or official;
  - c) Purchase Order Number and Contract number (if any) for the project-specific award;
  - d) Notation – **Hidalgo County- RFB: 2019-267-04-15-ABV “Construction of Bus Barn for Hidalgo County Sheriff’s Office” and**
  - e) Descriptive information as to the items or services delivered, including product code, item number, quantity, etc.
  
- Discount payments will be considered when offered (if applicable).
  
- Contact person for Billing and Payment questions:

**HIDALGO COUNTY AUDITOR’S OFFICE**  
 Postal/Mailing 2808 S. Business Hwy. 281  
 Edinburg, Texas 78539  
 956-318-2511

**SCHEDULE OF EVENTS:**

<b>RFB Opening, 9:30 A.M.</b>	<u>April 15, 2020</u>
<b>Award of Contract:</b>	<u>2020</u>
<b>Commence Work or Deliver Products:</b>	<u>2020</u>

**17. HIDALGO COUNTY HOLIDAYS:**

<b>2020 YEAR</b>	
<b>New Year’s Day</b>	<b>01/01/20</b>
<b>Martin Luther King Day</b>	<b>01/20/20</b>
<b>President’s Day</b>	<b>02/17/20</b>
<b>Good Friday</b>	<b>04/10/20</b>
<b>Memorial Day</b>	<b>05/25/20</b>
<b>Independence Day</b>	<b>07/03/20</b>
<b>Labor Day</b>	<b>09/07/20</b>
<b>Columbus Day</b>	<b>10/12/20</b>
<b>Veteran’s Day</b>	<b>11/11/20</b>
<b>Thanksgiving Day</b>	<b>11/26/20-11/27/20</b>
<b>Christmas Day</b>	<b>12/24/20-12/25/20</b>
<b>New Year’s Eve</b>	<b>12/31/20</b>

**BID, PAYMENT, OR PERFORMANCE BOND AND DEBARMENT CERTIFICATION;  
PAYMENT UNDER CONTRACT:**

The County may, and if mandated by statute, shall require a bid bond, a performance bond and/or a payment bond. Any such bond must be executed with a surety company authorized to do business Texas and shall meet any other requirements established by law or by County pursuant to applicable law.

- If the contract proposed is for the construction of public works or is for a contract for goods & services exceeding \$100,000, all respondents shall furnish a good and sufficient bid bond in the amount of five percent of the total contract price.
- In the event the contract exceeds Fifty Thousand Dollars (\$50,000.00), the respondent shall furnish a payment bond and a performance bond to the County for the full amount of the contract within thirty (30) days after the date of signing of the contract or issuance of a Purchase Order following the acceptance of a bid or proposal, but in any event prior to the commencement of actual work.
- If the contract is for \$50,000 or less, no money will be paid to the contractor until completion and acceptance of the work or the fulfillment of the purchase obligation to the County, and, if applicable, the receipt by County of satisfactory evidence that all subcontractors and material men have been paid.
- If a contract is for the construction, alteration or repair of public buildings or public works, the contractor *shall* provide a performance bond for a contract in excess of One Hundred Thousand Dollars (\$100,000.00) and *shall* provide a payment bond for a contract in excess of Twenty-Five Thousand Dollars (\$25,000.00) as required by Tex. Govt. Code Ch. 2253.
- For requirements contracts, bond requirements are determined by applying the proposed unit price to the estimated quantities included in the specifications.
- All participants are also required to furnish a certification or acknowledgment stating that the contractor or vendor is free from suspension or debarment pursuant to federal regulation 45 CFR Part 76. Register at SAM.gov, System for Award Management.

**19. TITLE VI NOTICE/ NONDISCRIMINATION:**

- a) By submitting a bid, the respondent certifies that it will comply with the following nondiscrimination statutes and their implementing regulations. Title VI of the Civil Rights Act of 1964, as amended (78 Stat.252, 42 U.S.C. §§2000d to 2000d-4) provides that no person in the United States shall, on the grounds of race, color, or national origin, be excluded from participation in, be denied the benefits of, or be otherwise subjected to discrimination under any program or activity for which the Recipient receives Federal financial assistance. Title VI has been broadened by related statutes, regulations and executive orders as found in Appendices "A" through "E" as delineated in the USDOT Standard Title VI/Non-Discrimination Assurances-Specific Assurances to prohibit discrimination on other grounds including, but not limited to, religion, sex, age, and disability. (Title VI-Appendices "A" through "E" are hereby attached as **Exhibit "G"**. The County's entire Title VI policy may be found at <https://www.hidalgocounty.us/2071/Title-VINondiscrimination-Plan> and is hereby incorporated by reference.

- b) The following required statement and the applicable provisions of the Title VI Appendices "A" through "E" expanding these protections to the categories described herein are hereby incorporated by reference as applicable.
- "The County of Hidalgo, in accordance with the provisions of Title VI of the Civil Rights Act of 1964 (78 Stat.252, 42 U.S.C. §§2000d to 2000d-4) and the Regulations, hereby notifies all respondents that it will affirmatively ensure that any contract entered into pursuant to this advertisement, disadvantaged business enterprises will be afforded full and fair opportunity to submit Bids in response to this invitation and will not be discriminated against on the grounds of race, color, or national origin in consideration for an award".
- c) The respondent will attach all applicable notices, including those referenced in Title VI – Appendices "A" through "E", to which it is obligated to provide or submit as part of the RFB.
- If applicable, Form FHWA 1273 – "*Required Contract Provisions Federal-Aid Construction Contracts*", must be physically attached to certain Federal-aid construction contracts. A contractor (or subcontractor) is required to insert Form FHWA 1273 in each subcontract and all lower-tier subcontracts. Form FHWA 1273 is attached as **Exhibit "I"**, and, if applicable, its provisions are incorporated in and made part of the contract entered into between the County and the successful respondent related to the present procurement.

## 20. ETHICAL STANDARDS:

- It shall be a breach of ethics to offer, give or agree to give any elected official, department head or employee, or former elected official, department head or employee, of the County, or for any elected official, department head or employee or former elected official, department head or employee of the County, to solicit, demand, accept or agree to accept from another person, entity or organization, a gratuity or an offer of employment in connection with any decision, approval, disapproval, recommendation, preparation or any part of a program requirement or purchase request, influencing the content of any specification or procurement standard, rendering of advice, investigation, auditing, or in any other advisory capacity in any proceeding or application, request for ruling, determination, claim or controversy, or other particular matter pertaining to any program requirement or a contract or subcontract, or to any solicitation or proposal therefore pending before any department or agency of the County.
- It shall be a breach of ethics for any payment, gratuity or offer of employment to be made by or on behalf of a subcontractor under a contract to the prime contractor or higher tier subcontractor for any contract for the County, or any person associated therewith, as an inducement for the award of a subcontract or order.
- Contracts awarded hereunder shall be in compliance with Tex. Loc. Govt. Code Chapter 171: Regulation of Conflicts of Interest of Officers of Municipalities, Counties and Certain Other Local Governments.
- **NOTICE:**  
*All communications by a vendor to the county, its officials, and department heads regarding this procurement shall be done through the Hidalgo County Purchasing Department.*

No vendor, its' representative, agent, or employee shall engage in private communication with a member of the Hidalgo County Commissioners Court or county department heads regarding any procurement of goods or services by the County from the date that the RFB, RFP, or RFB is released. No private communication regarding the purchase shall be permitted until the procurement process is complete and a purchase order is granted or a contract is entered into "Private Communication" means communication

with any vendor outside of a posted meeting of the governing body, a regular meeting of a standing or appointed committee, or negotiation with a vendor which has been specifically authorized by the governing body.

**21. DISCLOSURE OF CONFLICT OF INTEREST:**

Effective January 1, 2016, Chapter 176 of the Texas Local Government Code requires that any vendor, person, consultant or contractor considering doing business with Hidalgo County ("the County") to disclose in the Conflict of Interest Questionnaire (the "CIQ") attached as **Exhibit "D"**, the vendor, person, consultant or contractor's affiliation or business relationship that might cause a conflict of interest with the County. By law, the CIQ must be filed with the Hidalgo County Clerk's Office no later than the seventh business day after the date the person becomes aware of facts that require the statement to be filed. The disclosure requirement applies to a person or business that contracts or seeks to contract with Hidalgo County for the sale or purchase of property, goods or service. Any purchase order or contract resulting from this process shall be considered null and void if the successful respondent fails to comply with the Texas Local Government Code Chapter 176. Vendors, consultants, contractors and others who desire to conduct business with Hidalgo County are encouraged to refer to Texas Local Government Code Chapter 176 for details of this law. An offense under Texas Local Government Code Chapter 176 is a Class C Misdemeanor.

**If applicable, completed Form CIQ must be submitted to the Hidalgo County Clerk's Office located at 100 N. Clossner, Edinburg, Texas 78539 - Hidalgo County Courthouse.**

**COMPLETION AND SUBMISSION OF FORM CIQ IS THE SOLE RESPONSIBILITY OF THE PROSPECTIVE RESPONDENT. QUESTIONS REGARDING COMPLIANCE SHOULD BE DIRECTED TO YOUR LEGAL COUNSEL.**

**22. CERTIFICATE OF INTERESTED PARTIES (FORM HB1295):**

As of January 1, 2016, to comply with Texas Government Code Section §2252.908, and the rules issued by the Texas Ethics Commission found in Title 1, Section 46.1, 46.3 and 46.5 of the Texas Administrative Code, we have updated and revised our RFB packet. In accordance with these requirements, a business must submit a completed Certificate of Interested Parties Form 1295 to the County before the County may enter into a contract with the business entity. In box 3 of Form 1295, you will provide the **RFB No. 2019-267-04-15-ABV**, as shown on the packet. Once completed and filed with the Texas Ethics Commission, Form 1295 must be printed, signed, and submitted to our office either by facsimile transmission to (956) 292-7612 or via email to [alexandra.vela@co.hidalgo.tx.us](mailto:alexandra.vela@co.hidalgo.tx.us). Hidalgo County cannot enter into a contract until Form 1295 is submitted. Therefore, failure to timely submit signed Form 1295 may result in a delay of the award. Full instructions for completion and submittal of Form 1295 may be found on the Texas Ethics Commission website:

**<https://www.ethics.state.tx.us/tec/1295-Info.htm>**

**THE AWARDED VENDOR WILL HAVE THIRTY (30) DAYS FROM THE DATE THE HIDALGO COUNTY COMMISSIONERS' COURT APPROVES THIS AGREEMENT TO SUBMIT THE SIGNED FORM 1295. HIDALGO COUNTY CANNOT ENTER INTO A CONTRACT UNTIL FORM 1295 IS SUBMITTED.**

**23.** If during the life of any contract or bid awarded, the successful bidder's net prices generally available to other customers for items awarded herein are reduced below the contracted price, it is understood and agreed that the benefits of such reduction shall be extended to County.

**24.** Bids and all goods and services provided hereunder shall comply with all federal, state and local laws

concerning this type(s) of goods and/or services.

25. Minimum Standards for Responsible Prospective Respondents: A prospective respondent must affirmatively demonstrate the respondent's responsibility. A prospective respondent, by submitting an RFB, represents to County that it meets the following requirements:
- Possess or is able to obtain adequate financial resources as required to perform under this RFB;
  - Be able to comply with the required or proposed delivery schedule;
  - Have a satisfactory record of performance;
  - Have a satisfactory record of integrity and ethics; and
  - Be otherwise qualified and eligible to receive an award.
26. Successful bidder will pay or cause to be paid, without cost or expenses to County, all FICA, FUTA/SUTA and Federal Income Withholding Taxes of all employees, and all wages and benefits as required by Federal or State law. Successful bidder's officers, agents, and/or employees will not be entitled to any benefits of an employee or elected official of County, including, but not limited to, benefits associated with County's civil service system.
27. Any contract awarded to the successful bidder will be in effect until (a) the contract expires, (b) delivery and acceptance of products, and/or performance of services ordered, (c) terminated by County with thirty (30) days written notice prior to cancellation with or without cause.
28. Any supplemental project-specific contract award to a successful respondent will be in effect until (a) the contract expires, (b) delivery and acceptance of products, and/or performance of services ordered, or (c) terminated by County with thirty (30) days written notice prior to cancellation with or without cause.
29. County reserves the right to enforce performance of any contract awarded hereunder in any manner prescribed by law or deemed to be in the best interest of the County. County reserves the right to terminate the contract immediately in the event of breach or default by a successful respondent, or in the event, a successful respondent fails to:
- A. Meet schedules;
  - B. Pay any required fees or taxes; or
  - C. Otherwise, perform in accordance with the requirements.
30. **INDEMNIFICATION: Successful respondent shall defend, indemnify and save harmless County and all its elected officials, officers, agents and employees from all suits, actions, or other claims of any character, name and description brought for or on account of any injuries or damages received or sustained by any person, persons, or property on account of any negligent act or fault of the successful respondent, or of any agent, employee, subcontractor or supplier in the execution of, or performance under, any contract which may result from bid award or which arises from any event or casualty happening on or within County premises themselves or happening upon or in any halls, elevators, entrances, stairways or approaches of or to such County facilities. Successful respondent shall pay any judgment with costs which may be obtained against county growing out of such injury or damages, and shall, upon request, provide a defense to County by counsel reasonably acceptable to County. Successful respondent's indemnity hereunder shall include but is not limited to, claims relating to patent, copyright or trademark infringement and the like, arising out of the goods and services provided by successful respondent.**

1. The successful respondent shall warrant that all items/services shall conform to the specifications and/or all warranties provided under the Uniform Commercial Code and be free from all defects in material, workmanship and the like. Items supplied under a contract pursuant to this Request for Bids shall be subject to County approval. Items found to be defective or not meeting specifications shall be replaced by the successful respondent within two (2) business days at no expense to County. Items that are not picked up within one (1) week after notification shall be deemed a donation to County and may be used or disposed of at County's discretion and without waiver of any other rights of County as to the items' nonconformity.
32. This document and any disputes arising hereunder shall be governed and construed according to the laws of the State of Texas and will be performable exclusively in Hidalgo County, Texas.
33. The successful respondent shall not assign, sell, transfer or convey its rights under any awarded contract, in whole or in part, without the prior written consent of County.
34. Respondents shall provide with the Bids response, a list of at least three (3) references where like services have been supplied by their firm. Include the name of the business or government, address, telephone number and the name of the representative or contact person.
35. **CONTRACTS SUBJECT TO FEDERAL AWARD:**
  - The procurement standards of 2 CFR, Part 200, including, but not limited to 2 CFR 200.317-200.326, and applicable Hidalgo County Purchasing Policy (found at <https://www.hidalgocounty.us/805/County-Administrative-Policies>) address the County's requirements, as a non-Federal entity, in regards to contracts it enters into that are subject to federal award. Pursuant to 2 CFR 200.236, the County, as a non-Federal entity, is required to include into contracts subject to federal award, the applicable provisions and contract clauses described in Appendix II to 2 CFR 200, (Contract Provisions for non-Federal Entity Contracts Under Federal Awards). As such, **if applicable**, the provisions of the Hidalgo County Purchasing Policy, the procurement standards found in 2 CFR, Part 200, and the provisions of Appendix II to 2 CFR 200, and the required contract clauses found in **Exhibit "H"** are incorporated by reference, whether specified explicitly or not, as part of this procurement packet and any resulting agreement.
  - In addition, should the County's contracts under Federal award be subject to assistance from the Federal Emergency Management Agency (FEMA), FEMA requires the inclusion of contract terms in addition to those under Appendix II to 2 CFR 200. **If applicable**, the additional contract clauses required by FEMA are found in **Exhibit "H"** and incorporated by reference, whether specified explicitly or not, as part of this procurement packet and any resulting agreement. Should the contract be subject to assistance from FEMA, it is the County's intention to comply with FEMA requirements; therefore, any conflict in terms should be resolved as such.
  - **If applicable**, in accordance with 2 CFR 200.319, Contractors that develop or draft specifications, requirements, statements of work, or invitations for bids or requests for proposals must be excluded from competing for such procurements. (See 2 CFR 200.219). Additionally, Hidalgo County policy provides that for federal road projects, engineers, engineering firms, and/or a subsidiary, affiliate, or a consultant of the engineer or engineering firm who has received compensation from the County, that assist in the development of, or draft specifications, requirements, statements of work, or invitations for bids or requests for proposals, will be excluded from competing for such procurements (i.e...subsequent construction engineering/management and/or inspection/testing) for all other phases of the project. (See Hidalgo County Policy) "*Procedures for Selection and Contracting of Professional Service Providers for Federal Road Projects*" found at <https://www.hidalgocounty.us/805/County-Administrative-Policies>,

which, if applicable, is incorporated by reference, whether specified explicitly or not, as part of this procurement packet and any resulting agreement for all purposes.

**36. HISTORICALLY UNDERUTILIZED BUSINESS/DISADVANTAGED BUSINESS ENTERPRISES:**

The County is committed to ensuring that Historically Underutilized Businesses (HUB) and Disadvantaged Business Enterprises (DBE) such as small business enterprises (SBE), minority and women-owned business enterprises (MWBE) receive a fair and equal opportunity for participation in the County's procurement process. The County encourages the use of these enterprises both as prime and subcontractors. (See Exhibit "E" for requirements).

When federal funds are expended by the County, the County will take affirmative steps set forth in 2 CFR 200.321 to assure that small, minority, women-owned businesses and labor surplus area owned firms are used when possible. Pursuant to 2 CFR 321, the County requires that a prime contractor who uses sub-contractors take affirmative steps set forth in 2 CFR 200.321, including:

- a) Placing qualified small and minority business and women's business enterprises on solicitation lists;
- b) Assuring that small and minority businesses, and women's business enterprises are solicited whenever they are potential sources;
- c) Dividing total requirements, when economically feasible, into smaller tasks or quantities to permit maximum participation by small and minority businesses, and women's business enterprises;
- d) Establishing delivery schedules, where the requirement permits, which encourage participation by small and minority businesses, and women's business enterprises; and
- e) Using the services and assistance, as appropriate, of such organizations as the Small Business Administration and the Minority Business Development Agency of the Department of Commerce.

Nothing in this section is to be construed to require the County to award a contract other than as required by law and Hidalgo County policies and procedures.

**37. BOYCOTT ISRAEL VERIFICATION:** In accordance with the Texas Government Code Chapter 2270, the County may not enter into a contract for goods or services with a vendor unless the contract contains a written verification from the vendor that it does not boycott Israel and will not boycott Israel during the term of the contract. Pursuant to Sections 2270.001, 2270.002, 808.001, Texas Government Code:

1. "Boycott Israel" means refusing to deal with, terminating business activities with, or otherwise taking any action that is intended to penalize, inflict economic harm on, or limit commercial relations specifically with Israel, or with a person or entity doing business in Israel or in an Israeli-controlled territory, but does not include an action made for ordinary business purposes; and
2. "Company" has the meaning assigned by Section 808.001, except that the term does not include a sole proprietorship.
3. Section only applies to a contract that is between a governmental entity and a company with 10 or more full-time employees; and has a value of \$100,000 or more that is to be paid wholly or partly from public funds of the governmental entity.

By signing the acknowledgement form to this legal notice, Vendor understands that it is providing written verification and certification as indicated above. Any Vendor claiming an exception or otherwise unable to make this certification, shall submit an explanation on separate sheet(s). Failure to comply or providing false information may result in rejection of Vendor's submission. **Vendor shall indemnify and hold harmless the County, its elected officials, employees and agents for relying on this verification.**

38. TEX. GOVT. CODE CH. 2252- ATTESTATION-TERRORIST ORGANIZATIONS: By submitting a response to this procurement request and/or accepting this Contract, Company attests that it is not identified on a list of companies known to have contracts with or provide supplies or services to a foreign terrorist organization as designated by the U.S. Secretary of State. County will search a database maintained by the Texas State Comptroller. A contract may not be entered into with an entity that is identified therein. Search results shall be incorporated for all purposes as part of any resulting agreement entered into by the parties.
39. Respondents must provide all applicable documentation requested with this RFB in their response. Failure to provide this information may result in rejection of the Bids as non-conforming.
40. Awarded bidder shall assign a project superintendent who is directly employed by the Bidder, that superintendent will be required to be on the job on a daily basis. No subcontractors will be allowed to act as project superintendents at any point during the construction of said project.

Bidder shall have a significant business presence with the Rio Grande Valley Area, the business must be headquartered in either Hidalgo, Cameron, or Starr County or a local office must be located in either of the three counties (Hidalgo, Cameron, Starr) with at least thirty percent (30%) of the total company workforce employed at the local office. County reserves the right to request payrolls and any necessary documentation to confirm that the local office meets these requirements.

Bidders shall carefully examine the plans, specifications and other documents, visit the site of the work, and fully inform themselves as to all conditions and matters which can affect the work or cost thereof. Should the bidder find discrepancies in, or omissions from the plans, specifications or other documents, or should he/she be in doubt as their meaning, he/she should at once notify the Architect/Engineer and obtain clarification by addendum prior to submitting any bid.

Bidder certifies that it will carry liability coverage and workers compensation insurance coverage that meets the requirements set forth in this Request for Bids/Proposals when performing work on this project for Hidalgo County.

Furthermore, bidder certifies that any subcontractor on the project shall provide it with a certificate relating that all employees of the subcontractor also are provided with workers' compensation insurance coverage. Bidder will provide copies of all of these certificates to Hidalgo County during the course of the project for all subcontractors working on the project.

When applicable, in accordance with Chapter 2258 of the Texas Government Code and any other applicable laws, all contractors and subcontractors must comply with federally determined prevailing Davis-Bacon and Related Acts wage rates or the rates adopted by the County of Hidalgo.

Hidalgo County encourages the hiring of minority women subcontractors and/or suppliers whenever and wherever feasible.

**REQUEST FOR BIDS  
For  
HIDALGO COUNTY  
“Construction of Bus Barn for Hidalgo County Sheriff’s Office”  
RFB No.: 2019-267-04-15-ABV**

To: Martha L. Salazar, CPPB, Purchasing Agent  
Hidalgo County Purchasing Department  
Physical Address: 2802 S. Business Hwy. 281 Administration Building  
Mailing/Postal Address: 2812 S. Business Hwy. 281  
Edinburg, Texas 78539

Bidder acknowledges that it has examined this Request for Bids and specifications and is familiar with the conditions to be met. In accordance with the Specifications, and subject to all laws and regulations of the United States and state and local laws, the undersigned respondent proposes and commits to furnish all labor, equipment, material, software, and services as set forth in the documents hereinbefore mentioned. The undersigned bidder further agrees, upon acceptance of its Bids, to execute a contract and/or Purchase Order issued by Hidalgo County for performing and completing the work described in the Specifications within the time stated and for the prices proposed in the documents attached hereto and made a part hereof.

Bidder acknowledges receipt of all of the pages of the documents referenced in the Request for Bids Checklist presented in connection with this procurement. Bidder understands that Hidalgo County reserves the right to reject any or all RFB’s and further reserves the right to design the evaluation criteria to be used in selecting the lowest and best qualification.

Bidder acknowledges that by signature below, it is providing the required certifications, attestations, verifications and/or acknowledgments as referenced within this Request for Bids. Bidder acknowledges that any and all specifications, provisions, and attachments of this Request for Bids are incorporated into and made a part of any resulting agreement.

Bidder agrees that this RFB shall be good and may not be withdrawn for a period of ninety (90) calendar days after the scheduled closing time for receiving Bids, as contained in the specifications. An individual authorized to bind the company must sign the following section. Failure to execute this section may result in Bid rejection.

**Respectfully submitted,**

**Firm:** \_\_\_\_\_

**Address:** \_\_\_\_\_

**By:** \_\_\_\_\_

**Printed Name:** \_\_\_\_\_

**Title:** \_\_\_\_\_

## **INFORMATION FOR BIDDERS**

### **1. Receipt and Opening of Bids**

The Hidalgo County (herein called the "Owner"), invites bids on the form attached hereto, all blanks of which must be appropriately filled in. Bids will be received by the Owner at the Hidalgo County Purchasing Department until Wednesday, April 15, 2020 at 9:30 a.m. and then at said office publicly open and read aloud. The envelopes containing the bids must be sealed, addressed to Martha L. Salazar, Hidalgo County Purchasing Agent at 2812 S Business 281, Edinburg, Texas 78539 and designated as Bid for Hidalgo County. The owner may consider informal any bid not prepared and submitted in accordance with provisions hereof and may waive any informalities or reject any and all bids. Any bid may be withdrawn prior to the above scheduled time for the opening of bids or authorized postponement thereof. Any bid received after the time and date specified shall not be considered. No bidder may withdraw a bid within 90 days after the actual date of the opening thereof.

### **2. Preparation of Bid**

Each bid must be submitted on the prescribed forms and Certification by Bidder (contractor), concerning Labor Standards and Prevailing Wage Requirements. All blank spaces for bid prices must be filled in, in ink or typewritten, in both words and figures, and the foregoing Certificates must be fully completed and executed when submitted. Each bid must be submitted in a sealed envelopes bearing on the outside the name of the bidder, his address, and the name of the project for which the bid is submitted. If forwarded by mail, the sealed envelope containing the bid must be enclosed in another enveloped addressed as specified in the bid form.

### **3. Subcontracts**

The bidder is specifically advised that any person, firm, or other party to whom is proposed to ward a subcontract under this contract –

- a Must be acceptable to the Owner after verification of the current eligibility status,
- and,
- b Approval of the proposed subcontract award cannot be given by the Owner unless and until the proposed subcontractor has submitted the Certification and/or other evidence showing that it has fully complied with any reporting requirements to which it is or was subject. Although the bidder is not required to attach such Certification by proposed subcontractors to his bid, the bidder is here advised of this requirement so that appropriate action can be taken to prevent subsequent delay in subcontract awards.

#### **4. Telegraphic Modification**

Any bidder may modify his bid by telegraphic communication at any time prior to the scheduled closing time for receipt of bids, provided such telegraphic communication is received by the Owner prior to the closing time, and provided further, the Owner is satisfied that a written confirmation of the telegraphic modification over the signature of the bidder was mailed prior to the closing time. The telegraphic communication should not reveal the bid price but should provide the additional or subtraction or other modification so that the final prices or terms will not be known by the Owner until the sealed bid is opened. If written confirmation is not received within two days from the closing time, no consideration will be given to the telegraphic modification.

#### **5. Method of Bidding**

The Owner invites the following bid(s):      Project Name: Construction of a Bus Barn

#### **6. Qualifications of Bidder**

The Owner may make such investigations as he deems necessary to determine the ability of the bidder to perform the work, and the bidder shall furnish to the Owner all such information and data for this purpose as the Owner may request, the Owner reserves the right to reject any bid if the evidence submitted by, or investigation of, such bidder fails to satisfy the Owner that such bidder is properly qualified to carry out the obligations of the contract to complete the work contemplated therein. Conditional bids will not be accepted.

#### **7. Bid Security**

Each bid must be accompanied by certified check of the bidder, or a bid bond prepared on the form of bid bond attached hereto, duly executed by the bidder as principal and having as surety thereon a surety company approved by the Owner, in the amount of 5% of the bid. Such checks or bid bonds will be returned to all except the three lowest bidders within three days after the opening of bids, and the remaining checks, or bid bonds will be returned promptly after the Owner and the accepted bidder have executed the contract, or if no award has been made within 90 days after the date of the opening of bids, upon demand of the bidder at any time thereafter, so long as he has not been notified of the acceptance of his bid.

#### **8. Liquidated Damages for Failure to enter into Contract**

The successful bidder, upon his failure or refusal to execute and deliver the contract and bonds required within 10 days after he has received notice of the acceptance of his bid, shall forfeit to the Owner, as liquidated damages for such failure or refusal, the security deposited with his bid.

#### **9. Time of Completion and Liquidated Damages**

Bidder must agree to commence on or before a date to be specified in a Written "Notice to Proceed" of the Owner and to fully complete the project within **60 consecutive calendar days** thereafter. Bidder must agree also to pay as liquidated damages, the sum of **\$250.00** for each consecutive calendar day thereafter as hereinafter provided in the General Conditions.

#### **10. Condition of Work**

Each bidder must inform himself fully of the conditions relating to the construction of the project and the employment of labor thereon. Failure to do so will not relieve a successful bidder of his obligation to furnish all material and labor necessary to carry out the provisions of his contract. Insofar as possible the contractor, in carrying out his work, must employ such methods or means as will not cause any interruption of or interference with work of any other contractor.

#### **11. Addenda and Interpretations**

No interpretation of the meaning of the plans, specifications or other pre-bid documents will be made to any bidder orally.

Every request for such interpretation should be emailed to [alexandra.vela@co.hidalgo.tx.us](mailto:alexandra.vela@co.hidalgo.tx.us) Ter the opening of bids. Any all such interpretations and any supplemental instructions will be in the form of written addenda to the specifications which, if issued, will mailed by certified mail with return receipt requested to all prospective bidders (at the respective addresses furnished for such purposes), not later than three days prior to the date fixed for the opening of bids. Failure of any bidder to receive any such addendum or interpretation shall not relieve such bidder from any obligation under his bid as submitted. All addenda so issued shall become part of the contract documents.

#### **12. Security for Faithful Performance**

Simultaneously with his delivery of the executed contract; the contractor shall furnish a surety bond or bonds as security for faithful performance of this contract and for the payment of all persons performing labor on the project under this contract and furnishing materials in connection with this contract, as specified in the General Conditions included herein. The surety on such bond or bonds shall be a duly authorized surety company satisfactory to the Owner.

#### **13. Power of Attorney**

Attorney-in-fact who sign bonds or contract bonds must file with each bond a certified and effectively dated copy of their power of attorney.

#### **14. Notice of Special Conditions**

Attention is particularly called to those parts of the contract documents and specification which deal with the following;

- a Inspection and testing of materials
- b Insurance requirements
- c Wage rates
- d States allowances

**15. Laws and Regulations**

The bidder's attention is directed to the fact that all applicable State laws, municipal ordinances, and the rules and regulations of all authorities having jurisdiction of the project shall apply to the contract throughout, and they will be deemed to be included in the contract the same as though herein written out in full.

**16. Method of Award – Lowest Qualified Bidder**

If at the time this contract is to be awarded, the lowest base bid submitted by a responsible bidder does not exceed the amount of funds then estimated by the Owner as available to finance the contract the contract will be awarded on the base bid only. If such bid exceeds such amount, the Owner may reject all bids or may award the contract on the base bid combined with such deductible alternates applied in numerical order in which they are listed in the form of Bid, as produces a net amount which is within the available funds.

**17. Obligation of Bidder**

At the time of the opening of bids each bidder will be presumed to have inspected the site and to have read and to be thoroughly familiar with the plans and contract documents (including all addenda). The failure or omission of any bidder to examine any form, instrument or document shall in no way relieve any bidder from any obligation in respect of his bid.

**Supplement to Form HUD-4238-B®  
INFORMATION FOR BIDDERS**

**18. SAFETY STANDARDS AND ACCIDENTS PREVENTION**

With respect to all work performed under this contract, the contractor shall:

- 1 Comply with the safety standards provision of applicable laws, building and construction codes and the "Manual of Accident Prevention in Construction" published by the Associates General Contractors or America, the requirements of the Occupational Safety and Health Act of 1970 (Public Laws 91-596), and the requirements of Title 29 of the Code of Federal Regulations, Section 1518 as published in the "Federal Register", Volume 36, No 75, Saturday, April 17, 1971.
- 2 Exercise every precaution at all times for the prevention of accidents and the protection of persons (including employees) and property.
- 3 Maintain at his office or other well known place at the job site, all articles necessary for giving first aid to the injured, and shall make standing arrangements for the immediate removal to a hospital or a doctor's care of persons (including employee), whom may be injured on the job site. In no case shall employee be permitted to work at a job site before the employer has made a standing arrangement for removal of injured person to a hospital or a doctor's care.

**HIDALGO COUNTY**

**BID BOND**

KNOW ALL MEN BY THESE PRESENTS, That we, the undersigned \_\_\_\_\_  
\_\_\_\_\_ as Principal, and \_\_\_\_\_  
\_\_\_\_\_ as Surety, are hereby held and firmly bound  
unto \_\_\_\_\_ as OWNER in the penal sum of \_\_\_\_\_

\_\_\_\_\_ for the payment of which, well and truly to be made, we hereby jointly and severally bind ourselves, successors and assigns.

Signed, this \_\_\_\_\_ day of \_\_\_\_\_, 2\_\_\_\_\_.

The condition of the above obligation is such that whereas the Principal has submitted to \_\_\_\_\_  
\_\_\_\_\_ a certain BID, attached hereto and  
hereby made a part hereof to enter into a contract in writing for the

NOW, THEREFORE,

- (a) If said Bid shall be rejected, or
- (b) If said Bid shall be accepted and the Principal shall execute and deliver a contract in the Form of Contract attached hereto (properly completed in accordance with said BID) and Shall furnish a BOND for his faithful performance of said contract, and for the payment of all persons performing labor or furnishing materials in connection therewith, and shall in all other respects perform the agreement created by the acceptance of said BID, then, this obligation shall be void, otherwise the same shall remain in force and effect; it being expressly understood and agreed that the liability of the Surety for any and all claims hereunder shall, in no event, exceed the penal amount of this obligation is herein stated.

The Surety, for value received, hereby stipulates and agrees that the obligations of said Surety and its BOND shall be in no way impaired or affected by any extension of the time within which the OWNER may accept such Bid; and said Surety does hereby waive notice of any such extension.

IN WITNESS WHEREOF, the Principal and the Surety have hereunto set their hands and seals, and such of them as are corporations have caused their corporate seals to be hereto affixed and these presents to be signed by their proper officers, the day and year first set forth above.

\_\_\_\_\_  
Principal (L.S.)

\_\_\_\_\_  
Surety

By: \_\_\_\_\_

IMPORTANT – Surety companies executing BONDS must appear on the Treasury Department’s most current list (circular 570 as amended) and be authorized to transact business in the state where the project is located.











Project No.	18000
Issue No.	1
Issue Date	JANUARY 20, 2022
Drawn By	MLG
Checked By	ASL
Scale	AS NOTED
Sheet No.	1
Sheet Total	1

TECHNICAL SPECIFICATION  
**C1.03**  
Sheet Number

SET SQUARE CUT SET ON TOP OF CURB REFLECTOR ON THE EAST CORNER OF THE CURB. SET SQUARE CUT SET ON TOP OF CURB REFLECTOR ON THE SOUTH EAST CORNER OF THE CURB. SET SQUARE CUT SET ON TOP OF CURB REFLECTOR ON THE SOUTH WEST CORNER OF THE CURB. SET SQUARE CUT SET ON TOP OF CURB REFLECTOR ON THE NORTH WEST CORNER OF THE CURB.

1. THE GENERAL CONTRACTOR SHALL BE RESPONSIBLE FOR THE PROTECTION AND PRESERVATION OF ALL EXISTING UTILITIES AND STRUCTURES TO REMAIN. THE CONTRACTOR SHALL BE RESPONSIBLE FOR THE PROTECTION AND PRESERVATION OF ALL EXISTING UTILITIES AND STRUCTURES TO REMAIN. THE CONTRACTOR SHALL BE RESPONSIBLE FOR THE PROTECTION AND PRESERVATION OF ALL EXISTING UTILITIES AND STRUCTURES TO REMAIN.

2. THE CONTRACTOR SHALL BE RESPONSIBLE FOR THE PROTECTION AND PRESERVATION OF ALL EXISTING UTILITIES AND STRUCTURES TO REMAIN. THE CONTRACTOR SHALL BE RESPONSIBLE FOR THE PROTECTION AND PRESERVATION OF ALL EXISTING UTILITIES AND STRUCTURES TO REMAIN. THE CONTRACTOR SHALL BE RESPONSIBLE FOR THE PROTECTION AND PRESERVATION OF ALL EXISTING UTILITIES AND STRUCTURES TO REMAIN.

3. THE CONTRACTOR SHALL BE RESPONSIBLE FOR THE PROTECTION AND PRESERVATION OF ALL EXISTING UTILITIES AND STRUCTURES TO REMAIN. THE CONTRACTOR SHALL BE RESPONSIBLE FOR THE PROTECTION AND PRESERVATION OF ALL EXISTING UTILITIES AND STRUCTURES TO REMAIN. THE CONTRACTOR SHALL BE RESPONSIBLE FOR THE PROTECTION AND PRESERVATION OF ALL EXISTING UTILITIES AND STRUCTURES TO REMAIN.

4. THE CONTRACTOR SHALL BE RESPONSIBLE FOR THE PROTECTION AND PRESERVATION OF ALL EXISTING UTILITIES AND STRUCTURES TO REMAIN. THE CONTRACTOR SHALL BE RESPONSIBLE FOR THE PROTECTION AND PRESERVATION OF ALL EXISTING UTILITIES AND STRUCTURES TO REMAIN. THE CONTRACTOR SHALL BE RESPONSIBLE FOR THE PROTECTION AND PRESERVATION OF ALL EXISTING UTILITIES AND STRUCTURES TO REMAIN.

5. THE CONTRACTOR SHALL BE RESPONSIBLE FOR THE PROTECTION AND PRESERVATION OF ALL EXISTING UTILITIES AND STRUCTURES TO REMAIN. THE CONTRACTOR SHALL BE RESPONSIBLE FOR THE PROTECTION AND PRESERVATION OF ALL EXISTING UTILITIES AND STRUCTURES TO REMAIN. THE CONTRACTOR SHALL BE RESPONSIBLE FOR THE PROTECTION AND PRESERVATION OF ALL EXISTING UTILITIES AND STRUCTURES TO REMAIN.

6. THE CONTRACTOR SHALL BE RESPONSIBLE FOR THE PROTECTION AND PRESERVATION OF ALL EXISTING UTILITIES AND STRUCTURES TO REMAIN. THE CONTRACTOR SHALL BE RESPONSIBLE FOR THE PROTECTION AND PRESERVATION OF ALL EXISTING UTILITIES AND STRUCTURES TO REMAIN. THE CONTRACTOR SHALL BE RESPONSIBLE FOR THE PROTECTION AND PRESERVATION OF ALL EXISTING UTILITIES AND STRUCTURES TO REMAIN.

7. THE CONTRACTOR SHALL BE RESPONSIBLE FOR THE PROTECTION AND PRESERVATION OF ALL EXISTING UTILITIES AND STRUCTURES TO REMAIN. THE CONTRACTOR SHALL BE RESPONSIBLE FOR THE PROTECTION AND PRESERVATION OF ALL EXISTING UTILITIES AND STRUCTURES TO REMAIN. THE CONTRACTOR SHALL BE RESPONSIBLE FOR THE PROTECTION AND PRESERVATION OF ALL EXISTING UTILITIES AND STRUCTURES TO REMAIN.

8. THE CONTRACTOR SHALL BE RESPONSIBLE FOR THE PROTECTION AND PRESERVATION OF ALL EXISTING UTILITIES AND STRUCTURES TO REMAIN. THE CONTRACTOR SHALL BE RESPONSIBLE FOR THE PROTECTION AND PRESERVATION OF ALL EXISTING UTILITIES AND STRUCTURES TO REMAIN. THE CONTRACTOR SHALL BE RESPONSIBLE FOR THE PROTECTION AND PRESERVATION OF ALL EXISTING UTILITIES AND STRUCTURES TO REMAIN.

HCSO BUS BARN  
#C-18-142-05-08  
EDINBURG, TX 78541



**HALFF**  
LANDSCAPE ARCHITECTS  
1000 WEST BRYANT, SUITE 100  
EDINBURG, TEXAS 78541



PROJECT NO.	DATE
DATE	DESCRIPTION
DESIGNED BY	DATE
CHECKED BY	DATE
SCALE	AS NOTED
DRAWING TITLE	
PAVING & DIMENSION CONTROL PLAN	
C2.00	

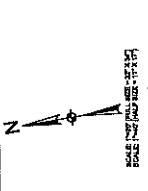

- LEGEND**
- SYMBOLS:**
- INLET
  - GRATE INLET
  - MARKER
  - DATE, VALVE & BOX
  - WATER METER
  - FIRE INHIBIT
  - SHOWER CLEAN OUT
  - LIGHT POLE
  - ELECTRIC BOX
  - POWER POLE
  - TELEPHONE POLE
  - 15' W FENCE
  - TRAP & MAN
  - STANDARD ELECTRIC
  - UNDERGROUND ELECTRIC
  - 60' GAS
  - 60' GAS LAC
  - 60' GAS LAC
  - TELEPHONE LAC
  - APPLY FINISH
  - 6\"/>
- FINISHES:**
- ASPHALT PAVEMENT
  - CONCRETE
  - CAUTION 1
  - UTILITY JOGGING

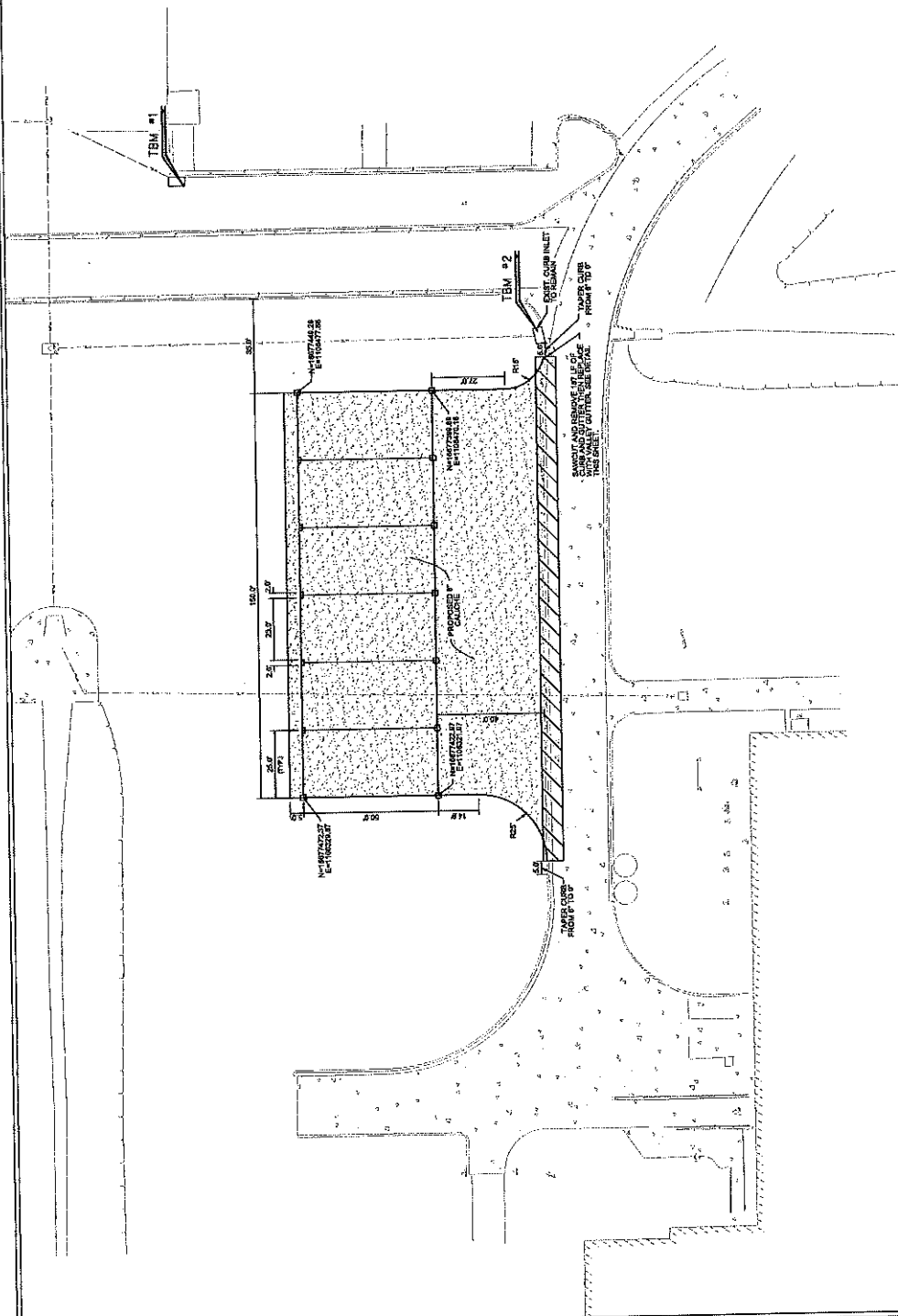

**ITEM #1**  
SET SQUARE CUT, SET ON TOP OF CURB ON THE EAST SIDE OF THE IMPROVEMENTS (SEE PLAN SHEET C2.01 FOR DETAILS)  
ELEVATION: 62.11 (FINISHED)  
ELEVATION: 62.11 (PROPOSED)  
ELEVATION: 62.11 (PROPOSED)

**ITEM #2**  
SET 7\"/>

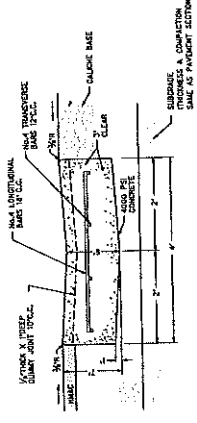

TYPICAL VALLEY GUTTER SECTION



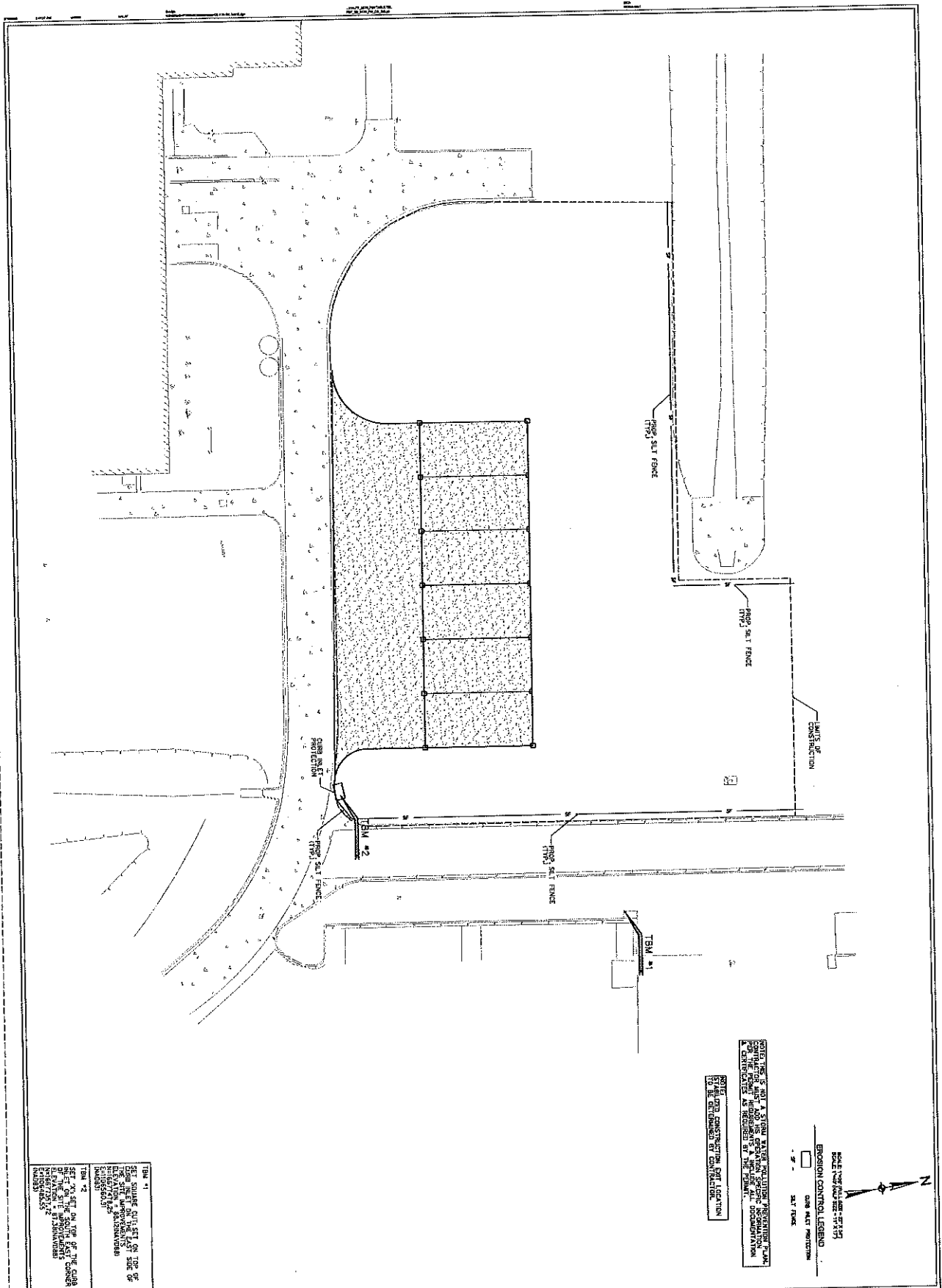

N

SCALE: 1" = 40' (SEE PLAN)

EROSION CONTROL LEGEND

CURB AND GUTTER  
 SUEF FENCE

1. THIS PLAN IS FOR A SUEF WATER TREATMENT PREVENTION PLAN.  
 2. THE SUEF SHALL BE CONSTRUCTED AND MAINTAINED IN ACCORDANCE WITH THE SUEF MANUAL.  
 3. THE SUEF SHALL BE CONSTRUCTED AND MAINTAINED IN ACCORDANCE WITH THE SUEF MANUAL.  
 4. THE SUEF SHALL BE CONSTRUCTED AND MAINTAINED IN ACCORDANCE WITH THE SUEF MANUAL.  
 5. THE SUEF SHALL BE CONSTRUCTED AND MAINTAINED IN ACCORDANCE WITH THE SUEF MANUAL.

TBM #1  
 SET 2" X 2" SET IN TOP OF THE CURB  
 OF THE SUEF AT THE POINT WHERE  
 THE SUEF ENTERS THE DRAINAGE  
 CHANNEL.

TBM #2  
 SET 2" X 2" SET IN TOP OF THE CURB  
 OF THE SUEF AT THE POINT WHERE  
 THE SUEF ENTERS THE DRAINAGE  
 CHANNEL.

Project No.	2018-001
Contract No.	18-142-05-08
Contractor	HALFF
Scale	AS NOTED
Sheet No.	CA.00

HCSO BUS BARN  
 HIDALGO COUNTY CONTRACT  
 #C-18-142-05-08  
 EDINBURG, TX 78541



Revision No.	Date	Description

**HALFF**  
 2000 WEST BURNING WOOD, SUITE 110  
 COLLEEN, TX 75940  
 (936) 450-0000



**HCSO BUS BARN**  
**HIDALGO COUNTY CONTRACT**  
**#C-18-142-05-08**  
**EDINBURG, TX 78541**

HCSO BUS BARN  
#C-18-142-05-08  
EDINBURG, TX 78541



HALFF  
CORPORATION  
1000 WEST 17TH AVENUE  
DENVER, COLORADO 80202

Revision	No.	Date	Description



Project No.	0408000
Contract No.	1800000000000000
Contractor	HALFF CORPORATION
Engineer	AS NOTED
Scale	AS NOTED
Sheet No.	1
Sheet Total	1
SUGGESTED EROSION CONTROL PLAN DETAILS	
C5.00	

**EROSION GENERAL NOTES**

- IT IS THE INTENT OF THIS SUGGESTED EROSION CONTROL PLAN AND WITHIN THE SPECIFICATIONS TO BE USED AS A GUIDE TO ESTABLISH A MINIMUM BASIS FOR EROSION CONTROL. THE CONTRACTOR SHALL BE RESPONSIBLE FOR OBTAINING ALL NECESSARY PERMITS AND COMPLIANCE WITH FEDERAL REGULATIONS. CONTRACTOR SHALL PREPARE AND SUBMIT A NOTICE OF INTENT PER THE REQUIREMENTS IN THE EROSION CONTROL PLAN. THE CONTRACTOR SHALL BE RESPONSIBLE FOR OBTAINING ALL NECESSARY PERMITS AND COMPLIANCE WITH FEDERAL REGULATIONS. CONTRACTOR SHALL PREPARE AND SUBMIT A NOTICE OF INTENT PER THE REQUIREMENTS IN THE EROSION CONTROL PLAN. THE CONTRACTOR SHALL BE RESPONSIBLE FOR OBTAINING ALL NECESSARY PERMITS AND COMPLIANCE WITH FEDERAL REGULATIONS. CONTRACTOR SHALL PREPARE AND SUBMIT A NOTICE OF INTENT PER THE REQUIREMENTS IN THE EROSION CONTROL PLAN.
- THE STORM WATER POLLUTION PREVENTION PLAN SHOULD ADDRESS THREE GOALS:
  - MINIMIZE THE EXPOSURE OF DISTURBED AREAS TO THE SHORTEST DURATION POSSIBLE.
  - REMOVAL OF SEDIMENT FROM STORM WATER BEFORE IT LEAVES THE SITE AVAILABLE UPON REQUEST, TO TEST.
- THE CONTRACTOR SHALL MAKE THE STORM WATER POLLUTION PREVENTION PLAN CONSTRUCTION, OPERATION OR MAINTENANCE OF THE PROJECT INCLUDING DESIGN AND ALL OPERATIONAL MATERIALS AND WORK SHALL BE ACCOMPLISHED BY THE CONTRACTOR AT NO ADDITIONAL EXPENSE TO THE OWNER.
- STABILIZATION MEASURES ARE TO BE INSPECTED AT A MINIMUM OF ONCE EVERY 14 DAYS AND WITHIN 24 HOURS AFTER ANY STORM EVENT GREATER THAN 0.5 INCHES. REPAIRS AND IMPROVEMENTS REVEALED BY THE INSPECTION MUST BE IMPLEMENTED WITHIN 7 CALENDAR DAYS FOLLOWING THE INSPECTION.
- AN INSPECTION REPORT THAT SUMMARIZES INSPECTION ACTIVITIES AND IMPLEMENTATION OF THE STORM WATER POLLUTION PREVENTION PLAN SHALL BE RETAINED AND MADE PART OF THE PLAN.
- ALL CONTRACTORS AND SUBCONTRACTORS IDENTIFIED IN THE PLAN MUST COMPLY AS TO AN UNDERSTANDING OF THE REQUIREMENTS OF THE STORM WATER POLLUTION PREVENTION PLAN. ANY ACTIVITY FOR WHICH APPROPRIATE CONSTRUCTION SITE MANAGEMENT PRACTICES TO PREVENT THE DISCHARGE OF OIL, GREASE, PAINTS, GASOLINE, AND OTHER POLLUTANTS TO STORM WATER, APPROPRIATE PRACTICES CAN INCLUDE:
  - DESIGNATING AREAS FOR EQUIPMENT MAINTENANCE AND REPAIR;
  - REGULAR COLLECTION OF WASTE;
  - CONTRACTOR SHALL MAINTAIN ALL WASTE RECEPTACLES AND DESIGNATING AND CONTROLLING EQUIPMENT MAINTENANCE;
  - CONTRACTOR SHALL MAINTAIN ALL WASTE RECEPTACLES AND DESIGNATING AND CONTROLLING EQUIPMENT MAINTENANCE;
- CONSTRUCTION MEANS INCLUDING APPROPRIATE CONSTRUCTION SITE MANAGEMENT PRACTICES TO PREVENT THE DISCHARGE OF OIL, GREASE, PAINTS, GASOLINE, AND OTHER POLLUTANTS TO STORM WATER, APPROPRIATE PRACTICES CAN INCLUDE:
  - DESIGNATING AREAS FOR EQUIPMENT MAINTENANCE AND REPAIR;
  - REGULAR COLLECTION OF WASTE;
  - CONTRACTOR SHALL MAINTAIN ALL WASTE RECEPTACLES AND DESIGNATING AND CONTROLLING EQUIPMENT MAINTENANCE;
  - CONTRACTOR SHALL MAINTAIN ALL WASTE RECEPTACLES AND DESIGNATING AND CONTROLLING EQUIPMENT MAINTENANCE;
- AREAS OF CONSTRUCTION ELSEWHERE ON THE JOB SITE SHALL CONFORM TO THE DETAILS SHOWN ON THE PLANS.
- DOORWAY AREAS, IF EXCAVATED, SHALL BE STABILIZED AND STABILIZED UTILIZING IMMEDIATELY AFTER CONSTRUCTION. THE CONTRACTOR SHALL MAINTAIN FINAL GRADING AND KEEP SEEDS AREAS WATERED UNTIL FULLY ESTABLISHED AND ACCEPTED BY THE OWNER.
- ALL NON-PAVED AREAS SHALL BE MULCHED AND SEEDS WITH EROSION PROTECTION IMMEDIATELY AFTER CONSTRUCTION. THE CONTRACTOR SHALL MAINTAIN FINAL GRADING AND KEEP SEEDS AREAS WATERED UNTIL FULLY ESTABLISHED AND ACCEPTED BY THE OWNER.
- THE CONTRACTOR SHALL CONSTRUCT A STABILIZED CONSTRUCTION EXIT AT ALL TRAFFIC EXIT POINTS PRIOR TO EXTING INTO ANY PAVED ROADWAY.

- STEEL POSTS WHICH SUPPORT THE SILT FENCE SHALL BE INSTALLED WITH SPACING TO BE DETERMINED BY THE CONTRACTOR. SPOUTS SHALL BE INSTALLED AT A MINIMUM OF 10'.
- THE TOP OF THE SILT FENCE SHALL BE TRIMMED WITH A SPARE OR MECHANICAL TRIMMER TO THE TOP OF THE FENCE. THE FENCE SHALL BE MAINTAINED AT ALL TIMES TO BE FREE OF OBSTRUCTIONS AND SHALL BE MAINTAINED AT ALL TIMES TO BE FREE OF OBSTRUCTIONS.
- THE SILT FENCE SHALL BE REMOVED WHEN THE SITE IS COMPLETELY STABILIZED AS DETERMINED BY THE CONTRACTOR. THE SILT FENCE SHALL BE REMOVED IN A MANNER AS TO NOT CONTRIBUTE TO ADDITIONAL EROSION.
- STEEL POSTS WHICH SUPPORT THE SILT FENCE SHALL BE INSTALLED WITH SPACING TO BE DETERMINED BY THE CONTRACTOR. SPOUTS SHALL BE INSTALLED AT A MINIMUM OF 10'.
- THE TOP OF THE SILT FENCE SHALL BE TRIMMED WITH A SPARE OR MECHANICAL TRIMMER TO THE TOP OF THE FENCE. THE FENCE SHALL BE MAINTAINED AT ALL TIMES TO BE FREE OF OBSTRUCTIONS AND SHALL BE MAINTAINED AT ALL TIMES TO BE FREE OF OBSTRUCTIONS.
- THE SILT FENCE SHALL BE REMOVED WHEN THE SITE IS COMPLETELY STABILIZED AS DETERMINED BY THE CONTRACTOR. THE SILT FENCE SHALL BE REMOVED IN A MANNER AS TO NOT CONTRIBUTE TO ADDITIONAL EROSION.

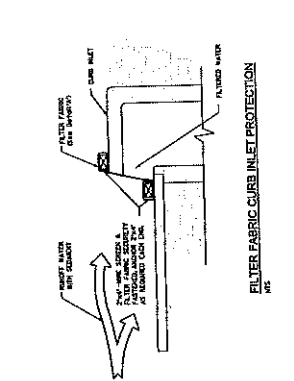
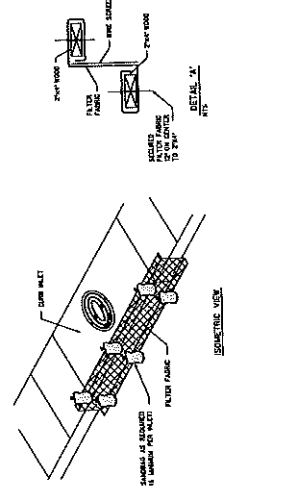
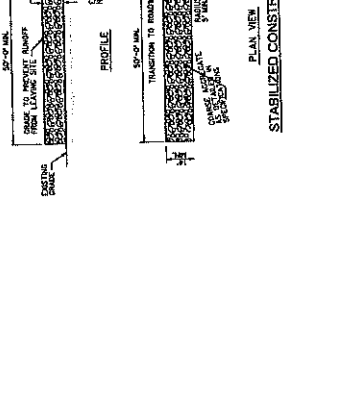
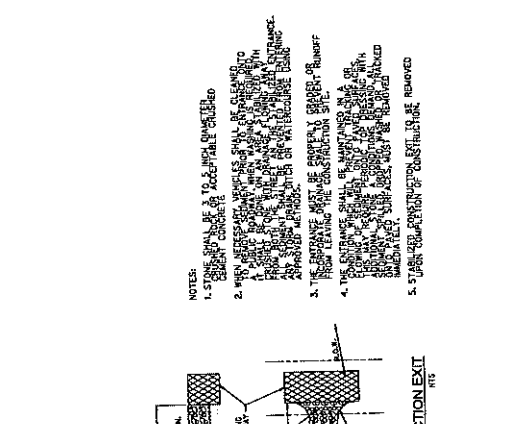
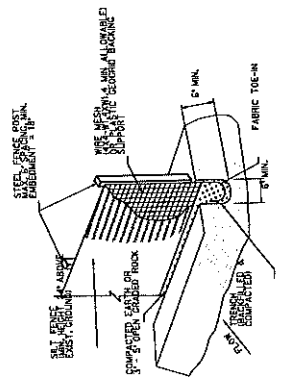

NOTE: SILT FENCE CURB INLET PROTECTION SHALL BE MAINTAINED AT ALL TIMES TO BE FREE OF OBSTRUCTIONS AND SHALL BE MAINTAINED AT ALL TIMES TO BE FREE OF OBSTRUCTIONS.

2. THE SILT FENCE SHALL BE REMOVED WHEN THE SITE IS COMPLETELY STABILIZED AS DETERMINED BY THE CONTRACTOR. THE SILT FENCE SHALL BE REMOVED IN A MANNER AS TO NOT CONTRIBUTE TO ADDITIONAL EROSION.

3. THE SILT FENCE SHALL BE REMOVED WHEN THE SITE IS COMPLETELY STABILIZED AS DETERMINED BY THE CONTRACTOR. THE SILT FENCE SHALL BE REMOVED IN A MANNER AS TO NOT CONTRIBUTE TO ADDITIONAL EROSION.

4. THE SILT FENCE SHALL BE REMOVED WHEN THE SITE IS COMPLETELY STABILIZED AS DETERMINED BY THE CONTRACTOR. THE SILT FENCE SHALL BE REMOVED IN A MANNER AS TO NOT CONTRIBUTE TO ADDITIONAL EROSION.

HCSO BUS BARN  
 HIDALGO COUNTY CONTRACT  
 #C-18-142-05-08  
 EDINBURG, TX 78541



HALFF  
 ARCHITECTS & ENGINEERS  
 1200 WEST WALKWAY, SUITE 100  
 EDINBURG, TEXAS 78541

Project No.	18-142-05-08
Sheet No.	C6.00
Scale	AS NOTED
Date	JANUARY 21, 2018
Drawn By	RAJ
Checked By	
Designed By	
Reviewed By	
Approved By	
Project Name	HCSO BUS BARN
Location	EDINBURG



PROJ. NO.: 18-142-05-08  
 SHEET NO.: C6.00  
 DATE: JANUARY 21, 2018  
 DRAWN BY: RAJ  
 CHECKED BY:  
 DESIGNED BY:  
 PROJECT NAME: HCSO BUS BARN  
 LOCATION: EDINBURG

ITEM #1  
 SET SQUARE CURB SET ON TOP OF  
 EXISTING CURB. THE WEST SIDE OF  
 THE CURB IS TO BE SET TO THE  
 ELEVATION OF 30.985. THE EAST  
 SIDE OF THE CURB IS TO BE SET TO  
 THE ELEVATION OF 30.985.

ITEM #2  
 SET 7/8" SET ON TOP OF THE CURB  
 AT THE SOUTH EAST CORNER  
 OF THE CURB. THE ELEVATION IS  
 TO BE 30.985. THE CURB IS TO  
 BE SET TO THE ELEVATION OF  
 30.985.

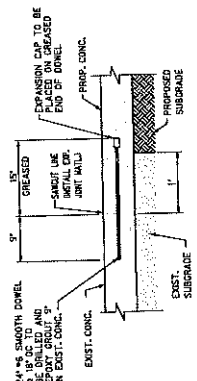

CONCRETE SAWCUT DETAIL  
 N18

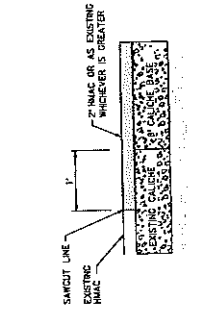

SAWCUT DETAIL  
 N18



# GENERAL NOTES

TABLE THREE

REQUIRED VERIFICATION AND INSPECTION OF REBAR CONSTRUCTION		CONSTRUCTION PERIOD	PERMANENT PERIOD	PERMANENT PERIOD	PERMANENT PERIOD
<b>1. MATERIAL VERIFICATION AND INSPECTION OF REBAR, WELD AND CONNECTIONS</b>					
a. VERIFICATION OF REBAR TYPE, GRADE, SIZE AND SPECIFICATION			X	AS 3100	
b. VERIFICATION OF WELD TYPE, GRADE, SIZE AND SPECIFICATION			X	AS 3100	
c. VERIFICATION OF WELDING PROCEDURE AND WELDER QUALIFICATION			X	AS 3100	
d. VERIFICATION OF WELDING PROCEDURE AND WELDER QUALIFICATION			X	AS 3100	
<b>2. INSPECTION OF REBAR INSTALLATION</b>					
a. REBAR TYPE CONNECTIONS		X	X	AS 3100 SECTION 4.1.1	
b. AIR-CURIAL CONNECTIONS		X	X	AS 3100 SECTION 4.1.1	
<b>3. MATERIAL VERIFICATION OF REINFORCING STEEL</b>					
a. VERIFICATION OF REINFORCING STEEL TYPE, GRADE, SIZE AND SPECIFICATION			X	AS 3100 SECTION 4.1.1	
b. VERIFICATION OF WELD TYPE, GRADE, SIZE AND SPECIFICATION			X	AS 3100 SECTION 4.1.1	
c. VERIFICATION OF WELDING PROCEDURE AND WELDER QUALIFICATION			X	AS 3100 SECTION 4.1.1	
<b>4. MATERIAL VERIFICATION OF WELD REBAR MATERIALS</b>					
a. VERIFICATION OF WELD TYPE, GRADE, SIZE AND SPECIFICATION			X	AS 3100 SECTION 4.1.1	
b. VERIFICATION OF WELDING PROCEDURE AND WELDER QUALIFICATION			X	AS 3100 SECTION 4.1.1	
<b>5. VERIFICATION OF WELDER QUALIFICATION</b>					
a. VERIFICATION OF WELDER TYPE, GRADE, SIZE AND SPECIFICATION			X	AS 3100 SECTION 4.1.1	
b. VERIFICATION OF WELDING PROCEDURE AND WELDER QUALIFICATION			X	AS 3100 SECTION 4.1.1	
<b>6. VERIFICATION OF WELDER QUALIFICATION</b>					
a. VERIFICATION OF WELDER TYPE, GRADE, SIZE AND SPECIFICATION			X	AS 3100 SECTION 4.1.1	
b. VERIFICATION OF WELDING PROCEDURE AND WELDER QUALIFICATION			X	AS 3100 SECTION 4.1.1	

TABLE THREE

REQUIRED VERIFICATION AND INSPECTION OF CONCRETE CONSTRUCTION		CONSTRUCTION PERIOD	PERMANENT PERIOD	PERMANENT PERIOD	PERMANENT PERIOD
<b>1. INSPECTION OF REBAR TYPE, GRADE, SIZE AND SPECIFICATION</b>					
a. VERIFICATION OF REBAR TYPE, GRADE, SIZE AND SPECIFICATION		X	X	AS 3100 SECTION 4.1.1	1910.4
b. VERIFICATION OF WELD TYPE, GRADE, SIZE AND SPECIFICATION		X	X	AS 3100 SECTION 4.1.1	1910.4
c. VERIFICATION OF WELDING PROCEDURE AND WELDER QUALIFICATION		X	X	AS 3100 SECTION 4.1.1	1910.4
d. VERIFICATION OF WELDING PROCEDURE AND WELDER QUALIFICATION		X	X	AS 3100 SECTION 4.1.1	1910.4
<b>2. INSPECTION OF REBAR INSTALLATION</b>					
a. REBAR TYPE CONNECTIONS		X	X	AS 3100 SECTION 4.1.1	1910.4
b. AIR-CURIAL CONNECTIONS		X	X	AS 3100 SECTION 4.1.1	1910.4
<b>3. MATERIAL VERIFICATION OF REINFORCING STEEL</b>					
a. VERIFICATION OF REINFORCING STEEL TYPE, GRADE, SIZE AND SPECIFICATION			X	AS 3100 SECTION 4.1.1	1910.4
b. VERIFICATION OF WELD TYPE, GRADE, SIZE AND SPECIFICATION			X	AS 3100 SECTION 4.1.1	1910.4
c. VERIFICATION OF WELDING PROCEDURE AND WELDER QUALIFICATION			X	AS 3100 SECTION 4.1.1	1910.4
<b>4. MATERIAL VERIFICATION OF WELD REBAR MATERIALS</b>					
a. VERIFICATION OF WELD TYPE, GRADE, SIZE AND SPECIFICATION			X	AS 3100 SECTION 4.1.1	1910.4
b. VERIFICATION OF WELDING PROCEDURE AND WELDER QUALIFICATION			X	AS 3100 SECTION 4.1.1	1910.4
<b>5. VERIFICATION OF WELDER QUALIFICATION</b>					
a. VERIFICATION OF WELDER TYPE, GRADE, SIZE AND SPECIFICATION			X	AS 3100 SECTION 4.1.1	1910.4
b. VERIFICATION OF WELDING PROCEDURE AND WELDER QUALIFICATION			X	AS 3100 SECTION 4.1.1	1910.4

TABLE THREE

REQUIRED VERIFICATION AND INSPECTION OF FORMWORK CONSTRUCTION		CONSTRUCTION PERIOD	PERMANENT PERIOD	PERMANENT PERIOD	PERMANENT PERIOD
<b>1. FORMWORK TYPE, GRADE, SIZE AND SPECIFICATION</b>					
a. VERIFICATION OF FORMWORK TYPE, GRADE, SIZE AND SPECIFICATION		X	X	AS 3100 SECTION 4.1.1	1910.4
b. VERIFICATION OF WELD TYPE, GRADE, SIZE AND SPECIFICATION		X	X	AS 3100 SECTION 4.1.1	1910.4
c. VERIFICATION OF WELDING PROCEDURE AND WELDER QUALIFICATION		X	X	AS 3100 SECTION 4.1.1	1910.4
<b>2. INSPECTION OF FORMWORK INSTALLATION</b>					
a. REBAR TYPE CONNECTIONS		X	X	AS 3100 SECTION 4.1.1	1910.4
b. AIR-CURIAL CONNECTIONS		X	X	AS 3100 SECTION 4.1.1	1910.4

TABLE THREE

REQUIRED VERIFICATION AND INSPECTION OF SOILS		CONSTRUCTION PERIOD	PERMANENT PERIOD	PERMANENT PERIOD	PERMANENT PERIOD
<b>1. SOIL TYPE, GRADE, SIZE AND SPECIFICATION</b>					
a. VERIFICATION OF SOIL TYPE, GRADE, SIZE AND SPECIFICATION		X	X	AS 3100 SECTION 4.1.1	1910.4
b. VERIFICATION OF WELD TYPE, GRADE, SIZE AND SPECIFICATION		X	X	AS 3100 SECTION 4.1.1	1910.4
c. VERIFICATION OF WELDING PROCEDURE AND WELDER QUALIFICATION		X	X	AS 3100 SECTION 4.1.1	1910.4

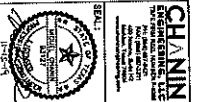

**HIDALGO COUNTY SHERIFFS  
OFFICE BUS BARN**  
Edinburg, Texas

PROJECT: \_\_\_\_\_  
JOB NO. 18162  
DATE: 11/15/18  
DRAWN BY: JWC  
CHECKED BY: JWC  
REVISION: \_\_\_\_\_  
DRAWING NO.: **S1.1**

**STRUCTURAL TESTS AND SPECIAL INSPECTION**

1. THE CONTRACTOR SHALL BE RESPONSIBLE FOR THE FOLLOWING:

- a. THE CONTRACTOR SHALL PROVIDE ALL MATERIALS AND LABOR FOR THE SPECIAL TESTS AND SPECIAL INSPECTION.
- b. THE CONTRACTOR SHALL PROVIDE ALL MATERIALS AND LABOR FOR THE SPECIAL TESTS AND SPECIAL INSPECTION.
- c. THE CONTRACTOR SHALL PROVIDE ALL MATERIALS AND LABOR FOR THE SPECIAL TESTS AND SPECIAL INSPECTION.
- d. THE CONTRACTOR SHALL PROVIDE ALL MATERIALS AND LABOR FOR THE SPECIAL TESTS AND SPECIAL INSPECTION.

2. THE CONTRACTOR SHALL BE RESPONSIBLE FOR THE FOLLOWING:

- a. THE CONTRACTOR SHALL PROVIDE ALL MATERIALS AND LABOR FOR THE SPECIAL TESTS AND SPECIAL INSPECTION.
- b. THE CONTRACTOR SHALL PROVIDE ALL MATERIALS AND LABOR FOR THE SPECIAL TESTS AND SPECIAL INSPECTION.
- c. THE CONTRACTOR SHALL PROVIDE ALL MATERIALS AND LABOR FOR THE SPECIAL TESTS AND SPECIAL INSPECTION.
- d. THE CONTRACTOR SHALL PROVIDE ALL MATERIALS AND LABOR FOR THE SPECIAL TESTS AND SPECIAL INSPECTION.



**HIDALGO COUNTY SHERIFFS**  
**OFFICE BUS BARN**  
 Edinburg, Texas

PROJECT:

JOB NO. 18102

DATE 11/17/18

DRAWN BY: JF

CHECKED BY: MC

REVISION:

DRAWING NO:

**S1.2**

**ROOF UPLIFT PLAN**  
 ROOFER

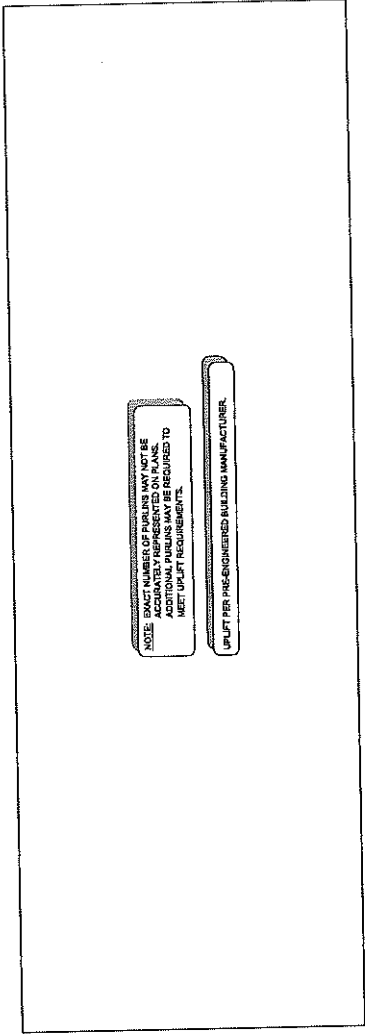

NOTE: EXACT NUMBER OF PURINS MAY NOT BE ACCURATELY REPRESENTED ON PLANS. ADDITIONAL PURINS MAY BE REQUIRED TO MEET UPLIFT REQUIREMENTS.

UPLIFT PER PRE-ENGINEERED BUILDING MANUFACTURER.

ALLOWABLE STRESS DESIGN	
EFFECTIVE WIND AREA	MAX PRESSURE
10	-133.8 psf
20	-83.8 psf
50	-53.9 psf
10	-24.2 psf
20	-14.2 psf
50	-9.4 psf

WIND LOAD PLAN NOTES:  
 1. PURINS DISMOUNT PRESSURE ACTING AWAY FROM BUILDING SURFACE SUCTION. THE PRESSURES FOR TYPICAL ROOF ARE SHOWN. THE LISTED VALUES MAY BE EXCEEDED UNLESS NOTED.

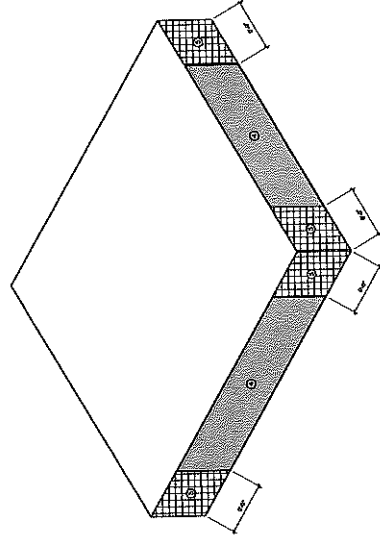

**COMPONENTS AND CLADDING**  
 SHEETS



# HIDALGO COUNTY SHERIFFS OFFICE BUS BARN

Edinburg, Texas

PROJECT:

JOB NO. 19182

DATE 11/15/19

DRAWN BY: JPC

CHECKED BY: MC

REVISIONS:

DRAWING NO:

S2.0

**FOUNDATION NOTES:**

1. CONTRACTOR TO VERIFY ALL DIMENSIONS WITH ARCHITECTURAL PLANS BEFORE COMMENCING WORK.
2. ALL DIMENSIONS UNLESS OTHERWISE NOTED TO BE TO FACE OF CONCRETE.
3. (C) INDICATES CONCRETE FINISH DETAIL LEVEL.

**FOUNDATION PLAN**  
SCALE: 1/4" = 1'-0"

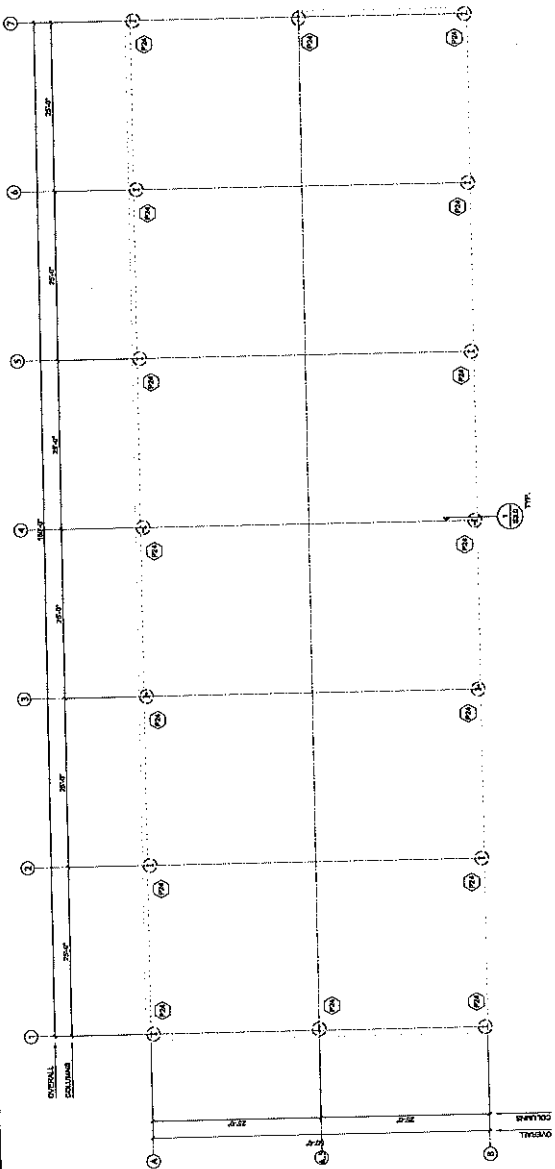

VERIFY ALL DIMENSIONS AND CONDITIONS TO BE FIRM DIMENSIONS TO FACE OF CONCRETE.

**FRAMING NOTES:**

1. CONTRACTOR TO VERIFY ALL DIMENSIONS WITH ARCHITECTURAL PLANS BEFORE COMMENCING WORK.
2. ALL DIMENSIONS UNLESS OTHERWISE NOTED TO BE TO FACE OF CONCRETE.
3. (C) INDICATES CONCRETE FINISH DETAIL LEVEL.

**ROOF FRAMING PLAN**  
SCALE: 1/4" = 1'-0"

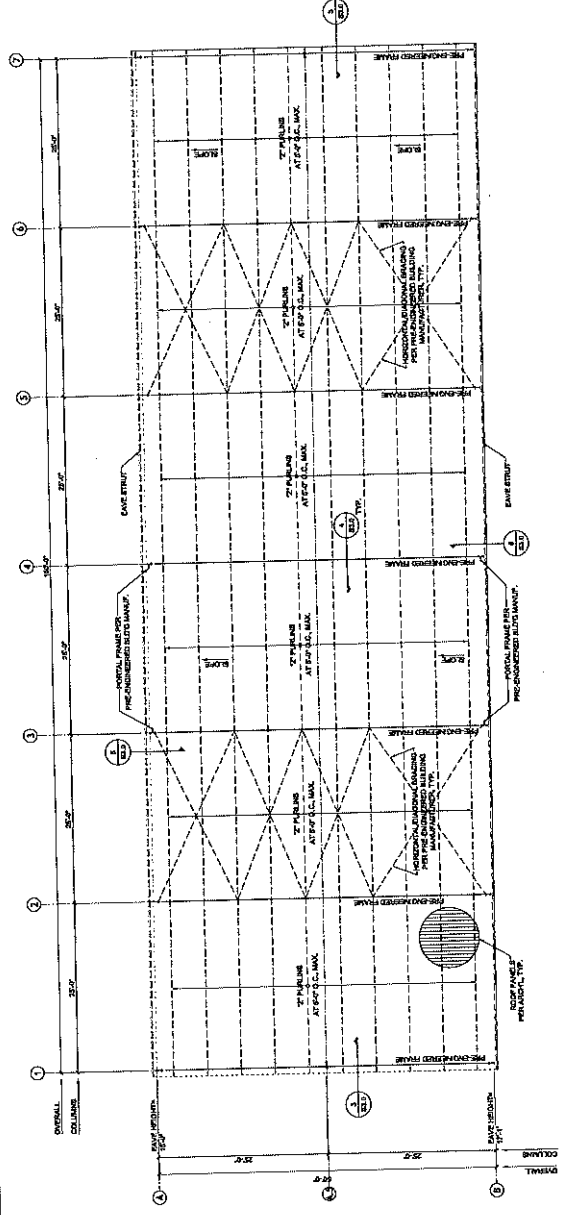

NOT USED	10	NOT USED	7	4	1
NOT USED	9	RIGID FRAME DETAIL	6	3	2
NOT USED	8	RIGID FRAME DETAIL	5	2	1

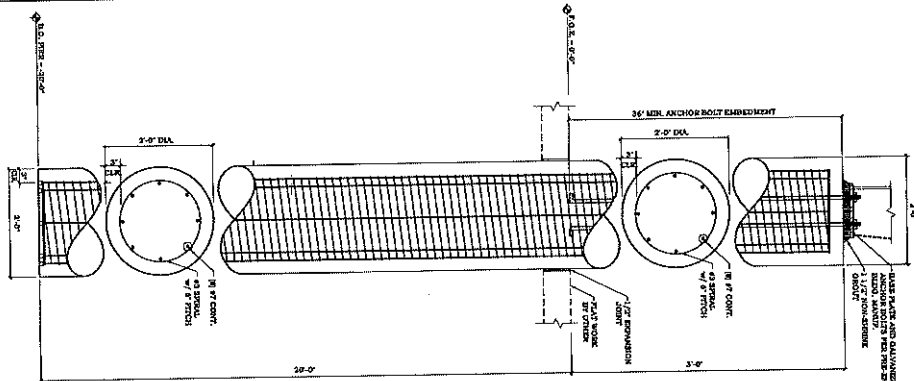
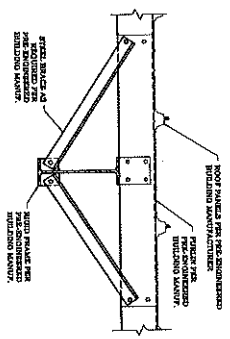
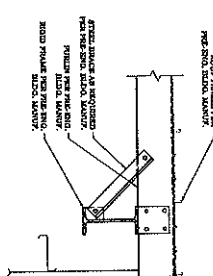
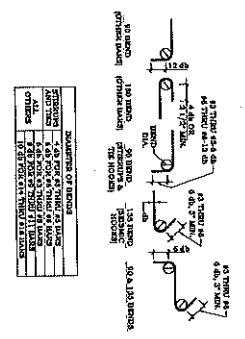
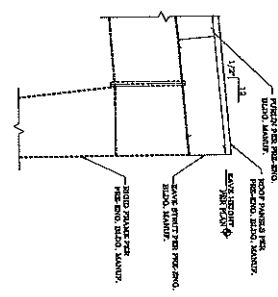
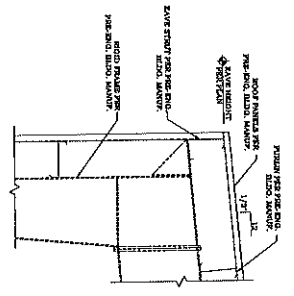

NOTES: 1. ALL DIMENSIONS ARE IN FEET AND INCHES UNLESS OTHERWISE SPECIFIED. 2. ALL DIMENSIONS ARE TO FACE UNLESS OTHERWISE SPECIFIED. 3. ALL DIMENSIONS ARE TO CENTER UNLESS OTHERWISE SPECIFIED. 4. ALL DIMENSIONS ARE TO SURFACE UNLESS OTHERWISE SPECIFIED. 5. ALL DIMENSIONS ARE TO CENTER UNLESS OTHERWISE SPECIFIED. 6. ALL DIMENSIONS ARE TO SURFACE UNLESS OTHERWISE SPECIFIED. 7. ALL DIMENSIONS ARE TO CENTER UNLESS OTHERWISE SPECIFIED. 8. ALL DIMENSIONS ARE TO SURFACE UNLESS OTHERWISE SPECIFIED. 9. ALL DIMENSIONS ARE TO CENTER UNLESS OTHERWISE SPECIFIED. 10. ALL DIMENSIONS ARE TO SURFACE UNLESS OTHERWISE SPECIFIED.

**HIDALGO COUNTY SHERIFFS OFFICE BUS BARN**  
Edinburg, Texas

PROJECT: HIDALGO COUNTY SHERIFFS OFFICE BUS BARN  
JOB NO. 18182  
DATE: 11/15/78  
DRAWN BY: J.P.  
CHECKED BY: J.C.  
REVISIONS:

CHAFFIN  
ENGINEERING  
1000 N. GULF  
HOUSTON, TEXAS 77002  
TEL: 770-231-1111

DRAWING NO.: **S3.0**



# ELECTRICAL GENERAL LEGEND

ALL SYMBOLS SHOWN MUST BE USED UNLESS OTHERWISE NOTED IN ALL SPECIFICATIONS.  
 DIMENSIONS ARE SHOWN UNLESS OTHERWISE NOTED AND ARE NOT TO SCALE.

SYMBOL	DESCRIPTION	INSTALLATION	SYMBOL	DESCRIPTION	INSTALLATION
	24V FLUORESCENT LIGHT FIXTURE	SEE PG. 504		SINGLE RECEPTACLE - 20A/125V/250V NEMA 5-20R	15' AFF
	24V FLUORESCENT LIGHT FIXTURE WITH JUNCTION BOX	SEE PG. 504		DUPLEX RECEPTACLE - 20A/125V/250V NEMA 5-20R	5' AFF
	24V FLUORESCENT LIGHT FIXTURE WITH JUNCTION BOX AND SWITCH	SEE PG. 504		20 AMP RECEPTACLE - 20A/125V/250V NEMA 5-20R	15' AFF
	FLUORESCENT STRIP LIGHT	SEE PG. 504		GROUNDING RECEPTACLE (THE DUPLEX TYPE UNDER ONE POLARITY UNDER ONE CONDUCTOR)	15' AFF
	FLUORESCENT STRIP LIGHT WITH JUNCTION BOX	SEE PG. 504		GROUNDING DUPLEX RECEPTACLE (TWO DUPLEX TYPES UNDER ONE CONDUCTOR)	15' AFF
	120V FLUORESCENT LIGHT FIXTURE WITH JUNCTION BOX	SEE PG. 504		DUPLEX RECEPTACLE IN JUNCTION BOX	15' AFF
	TRACK LIGHT WITH JUNCTION BOX	SEE PG. 504		FLOOR MOUNTED DUPLEX RECEPTACLE - FUSHI MOUNTED UNO	-
	JUNCTION BOX	SEE PG. 504		DUPLEX RECEPTACLE IN JUNCTION BOX	15' AFF
	JUNCTION BOX WITH SWITCH	SEE PG. 504		SPECIAL PURPOSE RECEPTACLE (NEMA NO. AS INDICATED)	15' AFF
	JUNCTION BOX WITH SWITCH AND RECEPTACLE	SEE PG. 504		JUNCTION BOX - SEE 8. NUMBER IS SHOWN	15' AFF
	JUNCTION BOX WITH SWITCH AND RECEPTACLE AND JUNCTION BOX	SEE PG. 504		JUNCTION BOX WITH SWITCH AND RECEPTACLE AND JUNCTION BOX AND JUNCTION BOX	15' AFF
	JUNCTION BOX WITH SWITCH AND RECEPTACLE AND JUNCTION BOX AND JUNCTION BOX AND JUNCTION BOX	SEE PG. 504		JUNCTION BOX WITH SWITCH AND RECEPTACLE AND JUNCTION BOX AND JUNCTION BOX AND JUNCTION BOX AND JUNCTION BOX	15' AFF
	JUNCTION BOX WITH SWITCH AND RECEPTACLE AND JUNCTION BOX AND JUNCTION BOX AND JUNCTION BOX AND JUNCTION BOX AND JUNCTION BOX	SEE PG. 504		JUNCTION BOX WITH SWITCH AND RECEPTACLE AND JUNCTION BOX AND JUNCTION BOX AND JUNCTION BOX AND JUNCTION BOX AND JUNCTION BOX AND JUNCTION BOX	15' AFF

## GENERAL ABBREVIATIONS

SYMBOL	DESCRIPTION	INSTALLATION	SYMBOL	DESCRIPTION	INSTALLATION
	480V MOTOR	SEE PG. 504		480V MOTOR WITH JUNCTION BOX	SEE PG. 504
	480V MOTOR WITH JUNCTION BOX	SEE PG. 504		480V MOTOR WITH JUNCTION BOX AND JUNCTION BOX	SEE PG. 504
	480V MOTOR WITH JUNCTION BOX AND JUNCTION BOX	SEE PG. 504		480V MOTOR WITH JUNCTION BOX AND JUNCTION BOX AND JUNCTION BOX	SEE PG. 504
	480V MOTOR WITH JUNCTION BOX AND JUNCTION BOX AND JUNCTION BOX	SEE PG. 504		480V MOTOR WITH JUNCTION BOX AND JUNCTION BOX AND JUNCTION BOX AND JUNCTION BOX	SEE PG. 504

E100

REVISIONS

No.	Date	Description

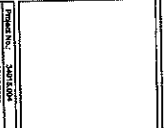

HALFF  
 800 WEST MILITARY ROAD  
 EDINBURG, TEXAS 78841  
 TEL: 409-382-1111

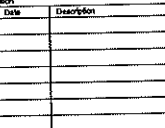

HCSO BUS BARN  
 HIDALGO COUNTY CONTRACT  
 #C-18-142-05-08  
 EDINBURG, TX 78841

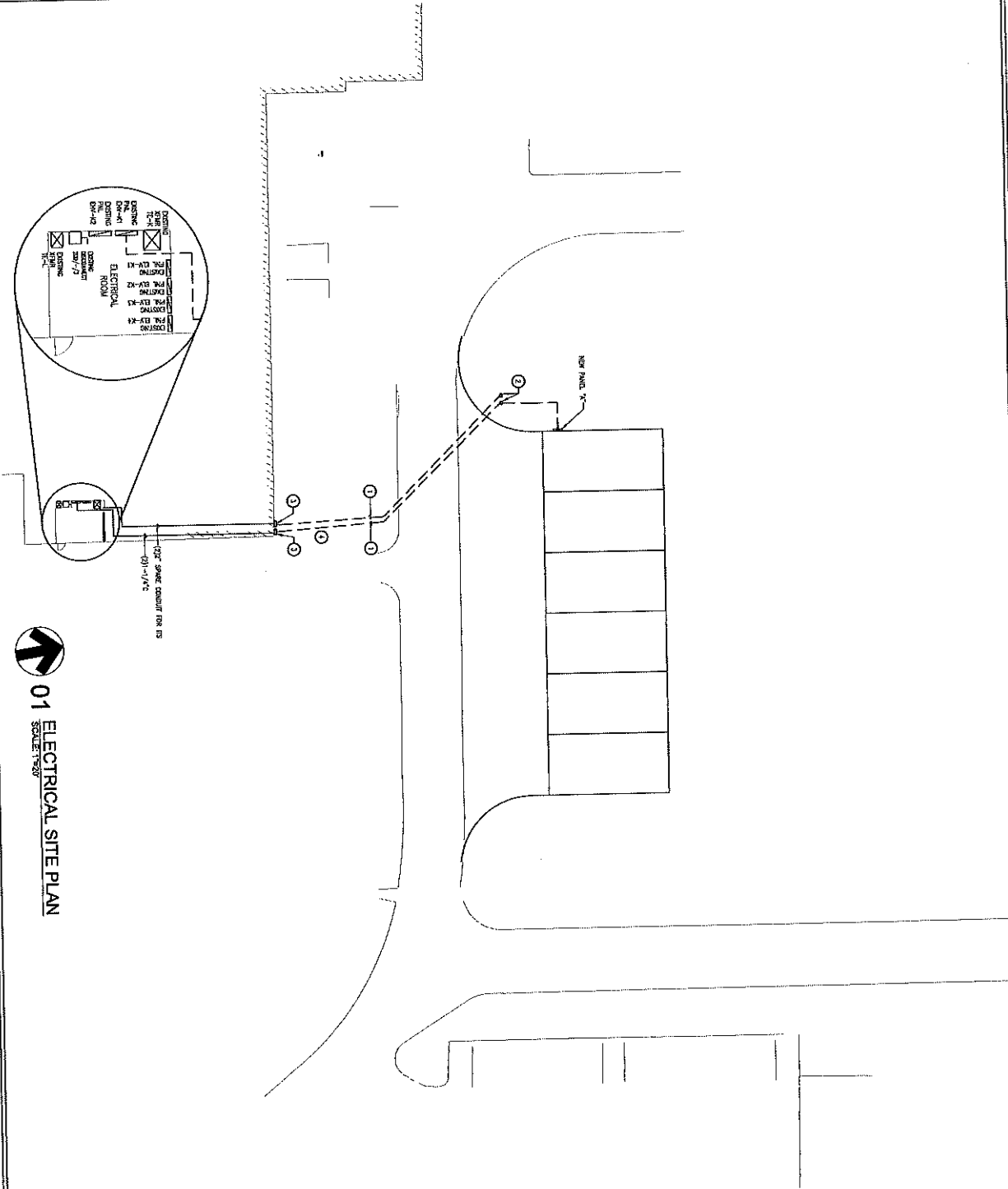

**01 ELECTRICAL SITE PLAN**  
 SCALE: 1/8"=1'-0"

- GENERAL NOTES:**
- A. SEE ALL NOTES FOR ELECTRICAL SYMBOL LEGEND.
  - B. REPRODUCTION OF THIS DRAWING FOR ANY OTHER PURPOSE WITHOUT THE WRITTEN PERMISSION OF THE ENGINEER IS STRICTLY PROHIBITED.
  - C. ANY WORK SHOWN ON ELECTRICAL DRAWINGS WHICH REQUIRES SEPARATION OF STRUCTURES FROM EXISTING STRUCTURES AND THE SHOWN DISCREPANCIES BETWEEN EXISTING CONDITIONS AND THE DRAWING SHALL BE CORRECTED TO THE DRAWING.
  - D. ALL WORK SHOWN ON ELECTRICAL DRAWINGS WHICH REQUIRES SEPARATION OF STRUCTURES FROM EXISTING STRUCTURES AND THE SHOWN DISCREPANCIES BETWEEN EXISTING CONDITIONS AND THE DRAWING SHALL BE CORRECTED TO THE DRAWING.
  - E. ALL WORK SHOWN ON ELECTRICAL DRAWINGS WHICH REQUIRES SEPARATION OF STRUCTURES FROM EXISTING STRUCTURES AND THE SHOWN DISCREPANCIES BETWEEN EXISTING CONDITIONS AND THE DRAWING SHALL BE CORRECTED TO THE DRAWING.
- KEY NOTES: -**
1. CONDUIT SHALL BE 100' PVC SHEET CONDUIT FOR MS AND 100' PVC SHEET CONDUIT FOR MS AND 100' PVC SHEET CONDUIT FOR MS.
  2. JUNCTION AND SPECIAL ELECTRICAL CHIEF SHALL BE 100' PVC SHEET CONDUIT FOR MS.
  3. CONDUIT SHALL BE 100' PVC SHEET CONDUIT FOR MS.
  4. CONDUIT SHALL BE 100' PVC SHEET CONDUIT FOR MS.

PROJECT NO.	01-01-01-01-01
DATE	05/18/2007
DESIGNED BY	AS NOTED
CHECKED BY	AS NOTED
DATE	05/18/2007
PROJECT NAME	ELECTRICAL SITE PLAN
SCALE	1/8"=1'-0"
PROJECT NO.	E101

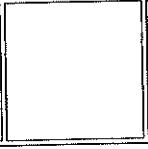

Revision		
No.	Date	Description



**HCSO BUS BARN**  
 HIDALGO COUNTY CONTRACT  
 #C-18-142-05-08  
 EDINBURG, TX 78841

HCSO BUS BARN  
 HIDALGO COUNTY CONTRACT  
 #C-18-142-05-08  
 EDINBURG, TX 78841



HALFF  
 300 WEST 19TH AVENUE, SUITE 100  
 DENVER, COLORADO 80202  
 PHONE: 303.733.8000  
 FAX: 303.733.8001  
 WWW.HALFF.COM

PROJECT NO.	
DATE	
DESIGNER	
CHECKED BY	
DATE	



DATE: 8-19-2019

PROJECT NO.	18101004
DATE	8/19/19
DESIGNER	J. D.
CHECKED BY	J. D.
DATE	8/19/19
SCALE	AS NOTED
ELECTRICAL POWER PLAN	
SHEET NO. E 102	
SHEET TOTAL	

**GENERAL NOTES:**

- A. REFER TO SHEET E09 FOR ELECTRICAL CHANGES.
- B. REFER TO SHEET E101 FOR ELECTRICAL SCHEDULES AND ONE-LINE DIAGRAM.

**KEY NOTES:**

1. CONTRACTOR SHALL FINISH AND INSTALL 200/250A SPECIAL PURPOSE RECEPTACLE COMPARTMENTS IN ALL BARN WALLS. REFER TO SHEET E101 FOR RECEPTACLE SCHEDULES AND ONE-LINE DIAGRAM.
2. ALL POWER ZONE UNIT INSTALLATIONS SHALL BE IN ACCORDANCE WITH THE NATIONAL ELECTRICAL CODE (NEC) AND LOCAL LAW.
3. REFER TO SHEET E101 FOR ONE-LINE DIAGRAM.

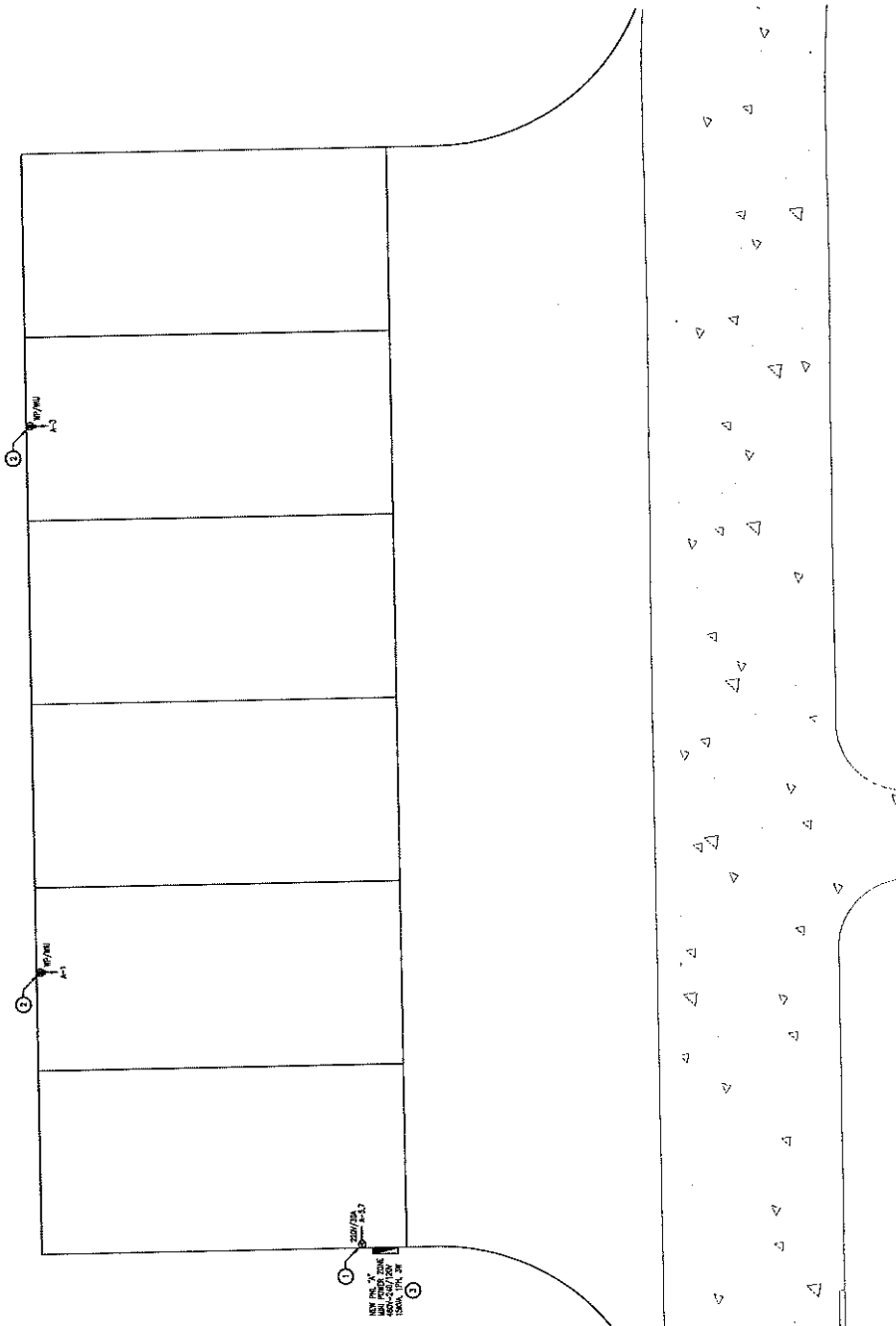

**01 ELECTRICAL POWER PLAN**  
 SCALE: 1/8" = 1'-0"



THIS DOCUMENT IS THE PROPERTY OF HALFF ENGINEERS, ARCHITECTS AND PLANNERS, INC. IT IS TO BE USED ONLY FOR THE PROJECT AND SITE SPECIFICALLY IDENTIFIED HEREIN. IT IS NOT TO BE REPRODUCED, COPIED, OR TRANSMITTED IN ANY FORM OR BY ANY MEANS, ELECTRONIC OR MECHANICAL, WITHOUT THE WRITTEN PERMISSION OF HALFF ENGINEERS, ARCHITECTS AND PLANNERS, INC.

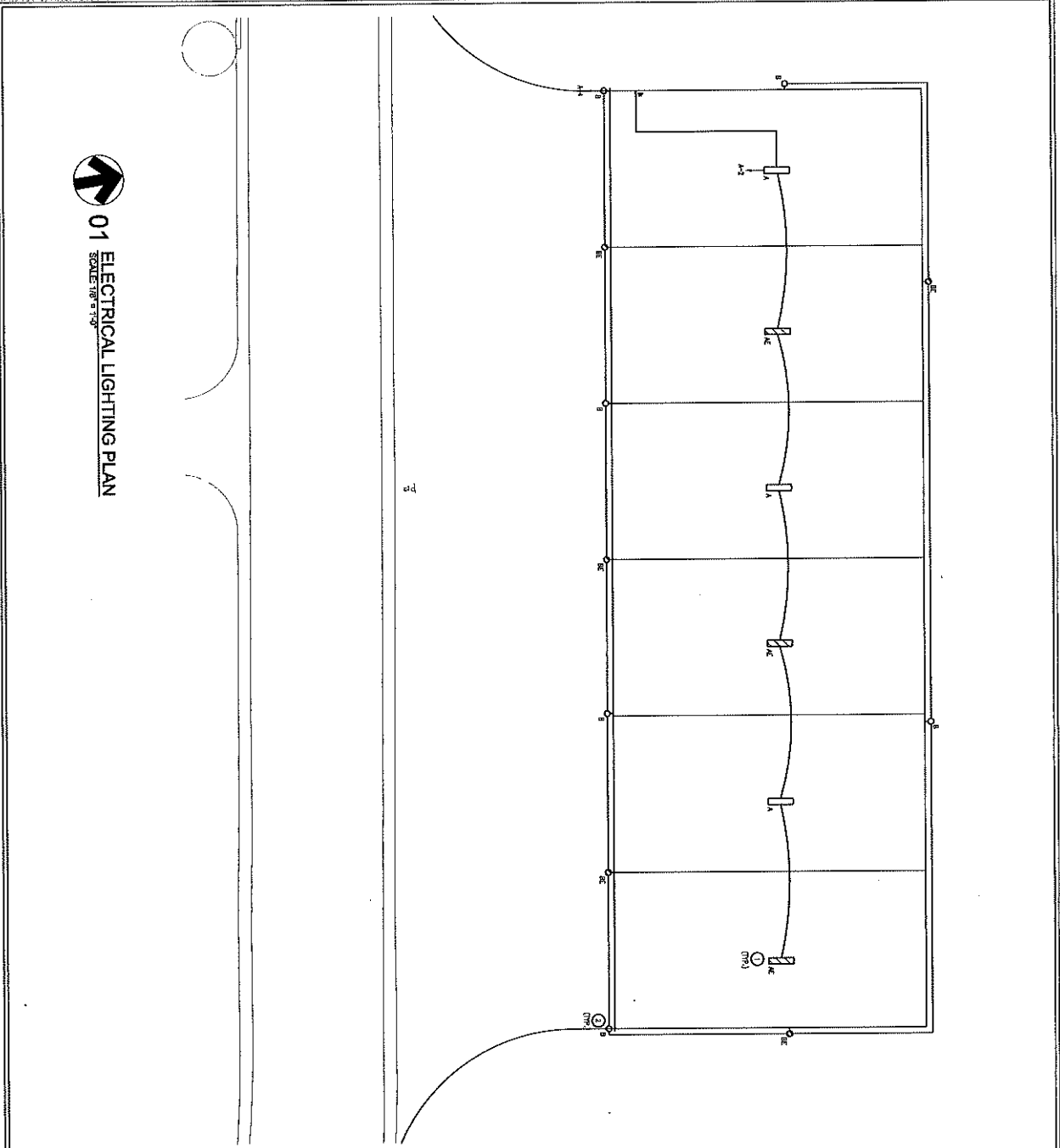

**01 ELECTRICAL LIGHTING PLAN**  
 SCALE: 1/8" = 1'-0"

**GENERAL NOTES:**  
 A. REFER TO SHEET FOR ELECTRICAL SYMBOLS, LEGEND.  
 B. VERIFY ALL CONDITIONS AND REQUIREMENTS BEFORE BEGINNING WORK.  
 C. VERIFY ALL CONDITIONS AND REQUIREMENTS BEFORE BEGINNING WORK.

**KEY NOTES:**  
 1. PROVIDE ALL MATERIALS AND LABOR FOR THE ENTIRE PROJECT.  
 2. CONTRACTOR SHALL VERIFY AND INSTALL ALL MATERIALS AND LABOR FOR THE ENTIRE PROJECT.  
 3. CONTRACTOR SHALL VERIFY AND INSTALL ALL MATERIALS AND LABOR FOR THE ENTIRE PROJECT.

**E103**  
 ELECTRICAL LIGHTING PLAN

Project No. 181976  
 Revision No. 01  
 Date 1/25/2018



Revision No.	Date	Description

**HALFF**  
 8000 WEST LA PLANY, SUITE 400  
 HOUSTON, TEXAS 77063  
 TEL: 281-444-8888  
 FAX: 281-444-8888  
 WWW.HALFF.COM



**HCSO BUS BARN**  
 HIDALGO COUNTY CONTRACT  
 #C-18-142-05-08  
 EDINBURG, TX 78641

TYPE	MANUF. & MODEL NUMBER	QUANTITY	WATTAGE	VOLTS	PHASE	REMARKS	NOTES
A	OSRAM 100W 120V	10	100	120	1	EXISTING	
B	OSRAM 100W 120V	10	100	120	1	PROPOSED	
C	OSRAM 100W 120V	10	100	120	1	PROPOSED	
D	OSRAM 100W 120V	10	100	120	1	PROPOSED	
E	OSRAM 100W 120V	10	100	120	1	PROPOSED	
F	OSRAM 100W 120V	10	100	120	1	PROPOSED	
G	OSRAM 100W 120V	10	100	120	1	PROPOSED	
H	OSRAM 100W 120V	10	100	120	1	PROPOSED	
I	OSRAM 100W 120V	10	100	120	1	PROPOSED	
J	OSRAM 100W 120V	10	100	120	1	PROPOSED	
K	OSRAM 100W 120V	10	100	120	1	PROPOSED	
L	OSRAM 100W 120V	10	100	120	1	PROPOSED	
M	OSRAM 100W 120V	10	100	120	1	PROPOSED	
N	OSRAM 100W 120V	10	100	120	1	PROPOSED	
O	OSRAM 100W 120V	10	100	120	1	PROPOSED	
P	OSRAM 100W 120V	10	100	120	1	PROPOSED	
Q	OSRAM 100W 120V	10	100	120	1	PROPOSED	
R	OSRAM 100W 120V	10	100	120	1	PROPOSED	
S	OSRAM 100W 120V	10	100	120	1	PROPOSED	
T	OSRAM 100W 120V	10	100	120	1	PROPOSED	
U	OSRAM 100W 120V	10	100	120	1	PROPOSED	
V	OSRAM 100W 120V	10	100	120	1	PROPOSED	
W	OSRAM 100W 120V	10	100	120	1	PROPOSED	
X	OSRAM 100W 120V	10	100	120	1	PROPOSED	
Y	OSRAM 100W 120V	10	100	120	1	PROPOSED	
Z	OSRAM 100W 120V	10	100	120	1	PROPOSED	

### PANELBOARD A

NO.	TYPE	MANUF. & MODEL NUMBER	QUANTITY	WATTAGE	VOLTS	PHASE	REMARKS	NOTES
1	Panelboard	ABB 1000A 120V/208V	1		120/208	3	EXISTING	
2	Breaker	ABB 100A 120V	1		120	1	EXISTING	
3	Breaker	ABB 100A 120V	1		120	1	EXISTING	
4	Breaker	ABB 100A 120V	1		120	1	EXISTING	
5	Breaker	ABB 100A 120V	1		120	1	EXISTING	
6	Breaker	ABB 100A 120V	1		120	1	EXISTING	
7	Breaker	ABB 100A 120V	1		120	1	EXISTING	
8	Breaker	ABB 100A 120V	1		120	1	EXISTING	
9	Breaker	ABB 100A 120V	1		120	1	EXISTING	
10	Breaker	ABB 100A 120V	1		120	1	EXISTING	
11	Breaker	ABB 100A 120V	1		120	1	EXISTING	
12	Breaker	ABB 100A 120V	1		120	1	EXISTING	
13	Breaker	ABB 100A 120V	1		120	1	EXISTING	
14	Breaker	ABB 100A 120V	1		120	1	EXISTING	
15	Breaker	ABB 100A 120V	1		120	1	EXISTING	
16	Breaker	ABB 100A 120V	1		120	1	EXISTING	
17	Breaker	ABB 100A 120V	1		120	1	EXISTING	
18	Breaker	ABB 100A 120V	1		120	1	EXISTING	
19	Breaker	ABB 100A 120V	1		120	1	EXISTING	
20	Breaker	ABB 100A 120V	1		120	1	EXISTING	
21	Breaker	ABB 100A 120V	1		120	1	EXISTING	
22	Breaker	ABB 100A 120V	1		120	1	EXISTING	
23	Breaker	ABB 100A 120V	1		120	1	EXISTING	
24	Breaker	ABB 100A 120V	1		120	1	EXISTING	
25	Breaker	ABB 100A 120V	1		120	1	EXISTING	
26	Breaker	ABB 100A 120V	1		120	1	EXISTING	
27	Breaker	ABB 100A 120V	1		120	1	EXISTING	
28	Breaker	ABB 100A 120V	1		120	1	EXISTING	
29	Breaker	ABB 100A 120V	1		120	1	EXISTING	
30	Breaker	ABB 100A 120V	1		120	1	EXISTING	
31	Breaker	ABB 100A 120V	1		120	1	EXISTING	
32	Breaker	ABB 100A 120V	1		120	1	EXISTING	
33	Breaker	ABB 100A 120V	1		120	1	EXISTING	
34	Breaker	ABB 100A 120V	1		120	1	EXISTING	
35	Breaker	ABB 100A 120V	1		120	1	EXISTING	
36	Breaker	ABB 100A 120V	1		120	1	EXISTING	
37	Breaker	ABB 100A 120V	1		120	1	EXISTING	
38	Breaker	ABB 100A 120V	1		120	1	EXISTING	
39	Breaker	ABB 100A 120V	1		120	1	EXISTING	
40	Breaker	ABB 100A 120V	1		120	1	EXISTING	
41	Breaker	ABB 100A 120V	1		120	1	EXISTING	
42	Breaker	ABB 100A 120V	1		120	1	EXISTING	
43	Breaker	ABB 100A 120V	1		120	1	EXISTING	
44	Breaker	ABB 100A 120V	1		120	1	EXISTING	
45	Breaker	ABB 100A 120V	1		120	1	EXISTING	
46	Breaker	ABB 100A 120V	1		120	1	EXISTING	
47	Breaker	ABB 100A 120V	1		120	1	EXISTING	
48	Breaker	ABB 100A 120V	1		120	1	EXISTING	
49	Breaker	ABB 100A 120V	1		120	1	EXISTING	
50	Breaker	ABB 100A 120V	1		120	1	EXISTING	
51	Breaker	ABB 100A 120V	1		120	1	EXISTING	
52	Breaker	ABB 100A 120V	1		120	1	EXISTING	
53	Breaker	ABB 100A 120V	1		120	1	EXISTING	
54	Breaker	ABB 100A 120V	1		120	1	EXISTING	
55	Breaker	ABB 100A 120V	1		120	1	EXISTING	
56	Breaker	ABB 100A 120V	1		120	1	EXISTING	
57	Breaker	ABB 100A 120V	1		120	1	EXISTING	
58	Breaker	ABB 100A 120V	1		120	1	EXISTING	
59	Breaker	ABB 100A 120V	1		120	1	EXISTING	
60	Breaker	ABB 100A 120V	1		120	1	EXISTING	

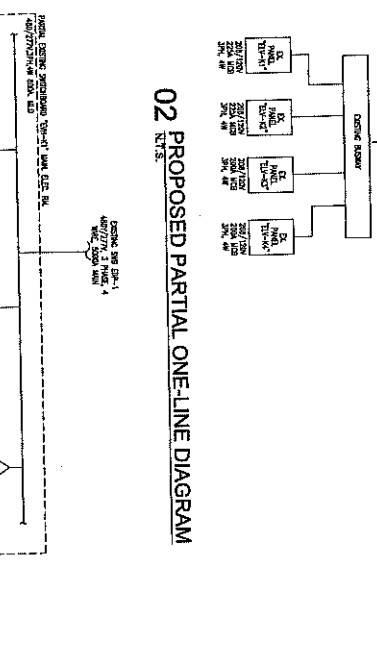
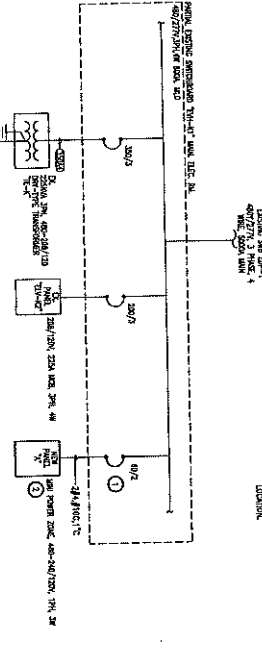

**HALFF**  
ELECTRICAL CONTRACTORS

**HCSO BUS BARN**  
HIDALGO COUNTY CONTRACT  
#C-18-142-05-08  
EDINBURG, TX 78641

Professional Engineer  
Electrical Engineering  
No. 10400  
State of Texas

Revision No.	Date	Description

PROJECT: BUS BARN  
OWNER: HIDALGO COUNTY  
DESIGNED BY: HALFF  
CHECKED BY: HALFF  
DATE: 11/15/2018

ELECTRICAL SCHEDULES  
E-104





PLUMBING ABBREVIATIONS

<b>A</b>	AMERICAN WITH REGULATING VALVE	<b>H</b>	HOSE BIBB	<b>O</b>	OSHA	<b>T</b>	THERMOCHEMICAL
<b>B</b>	BULLER BUILDING	<b>I</b>	INCH	<b>P</b>	PVC	<b>W</b>	WATER METER
<b>C</b>	COMPENSATE DRAIN	<b>M</b>	MARK VALUE	<b>R</b>	REFERENCE	<b>WE</b>	WATER SUPPLY
<b>D</b>	DIAMETER	<b>N</b>	NATIONAL ELECTRICAL	<b>S</b>	SAFETY		
<b>E</b>	EXTINGUISHING AGENT	<b>NI</b>	NIPPLE	<b>SP</b>	SUPPLY		
<b>F</b>	FLOOR FINISH	<b>NM</b>	NIPPLE	<b>ST</b>	STEEL		
<b>G</b>	GROUNDING	<b>NS</b>	NIPPLE	<b>SW</b>	SWITCH		
<b>H</b>		<b>OSHA</b>		<b>TR</b>	TRAP		
<b>I</b>		<b>RE</b>		<b>W</b>	WATER		
<b>J</b>		<b>RF</b>		<b>WE</b>	WATER SUPPLY		
<b>K</b>		<b>SI</b>					
<b>L</b>		<b>SM</b>					
<b>M</b>		<b>SP</b>					
<b>N</b>		<b>ST</b>					
<b>O</b>		<b>SW</b>					
<b>P</b>		<b>TR</b>					
<b>Q</b>		<b>WE</b>					
<b>R</b>		<b>WE</b>					
<b>S</b>							
<b>T</b>							
<b>U</b>							
<b>V</b>							
<b>W</b>							
<b>X</b>							
<b>Y</b>							
<b>Z</b>							

PLUMBING PIPING MATERIALS SCHEDULE

MARK	PIPE TYPE	PIPE SIZE	FITTINGS	JOINTS	HANDERS	UNIONS	VALVES	NOTES
1/8"	1/8" SCH 40	1/8"	90° ELBOW	FLANGES	NONE	NONE	NONE	DOMESTIC COLD WATER SERVICE
1/2"	1/2" SCH 40	1/2"	90° ELBOW	FLANGES	1/2" WELDED	1/2" WELDED	1/2" WELDED	DOMESTIC COLD WATER SERVICE
3/4"	3/4" SCH 40	3/4"	90° ELBOW	FLANGES	3/4" WELDED	3/4" WELDED	3/4" WELDED	DOMESTIC COLD WATER SERVICE
1"	1" SCH 40	1"	90° ELBOW	FLANGES	1" WELDED	1" WELDED	1" WELDED	DOMESTIC COLD WATER SERVICE

PLUMBING SCHEDULE

MARK	PIPE TYPE	PIPE SIZE	FITTINGS	JOINTS	HANDERS	UNIONS	VALVES	NOTES
1/8"	1/8" SCH 40	1/8"	90° ELBOW	FLANGES	NONE	NONE	NONE	DOMESTIC COLD WATER SERVICE
1/2"	1/2" SCH 40	1/2"	90° ELBOW	FLANGES	1/2" WELDED	1/2" WELDED	1/2" WELDED	DOMESTIC COLD WATER SERVICE
3/4"	3/4" SCH 40	3/4"	90° ELBOW	FLANGES	3/4" WELDED	3/4" WELDED	3/4" WELDED	DOMESTIC COLD WATER SERVICE
1"	1" SCH 40	1"	90° ELBOW	FLANGES	1" WELDED	1" WELDED	1" WELDED	DOMESTIC COLD WATER SERVICE

PLUMBING SYMBOL LEGEND

SYMBOL	DESCRIPTION	SYMBOL	DESCRIPTION
—	SMOOTH WASTE LINE	—	WALL VALVE
—	VENT LINE	—	CHECK VALVE
—	DOMESTIC WASTE LINE	—	GATE VALVE
—	PRIMARY ROOF DRAIN LINE	—	GAS COOK
—	CONDENSATE DRAIN LINE	—	RAINWATER VALVE
—	DOMESTIC COLD WATER	—	WATER METER ASSEMBLY
—	DOMESTIC HOT WATER (180°)	—	DOSE VALVE
—	DOMESTIC HOT WATER (140°)	—	FLOOR CLEANOUT
—	DOMESTIC HOT WATER RETURN LINE	—	FLOOR SINK
—	CONDENSATE RETURN ROOF DRAIN	—	ROOF DRAIN / OVERFLOW ROOF DRAIN
—	CONDENSATE RETURN AIR LINE	—	ROSE BIRD
—	COMPRESSED AIR LINE	—	WALL HYDRANT
—	NATURAL GAS LINE	—	SHOWER
—	EXISTING TO NEW CONNECTION	—	BRANCH - TOP CONNECTION
—	EXISTING TO NEW CONNECTION	—	BRANCH - BOTTOM CONNECTION
—	PIPE RISE	—	PIPE DROP
—	PLUMBING LEGAL REFERENCE	—	PLUMBING LEGAL REFERENCE

GENERAL NOTES

THE DESIGN NOTES SHALL APPLY TO ALL MECHANICAL, ELECTRICAL AND PLUMBING (MEP) SYSTEMS. THE CONTRACTOR SHALL BE RESPONSIBLE FOR VERIFYING THE ACCURACY OF ALL DIMENSIONS AND CONDITIONS AS NOTED ON THE DRAWINGS. THE CONTRACTOR SHALL BE RESPONSIBLE FOR OBTAINING ALL NECESSARY PERMITS AND APPROVALS FROM THE LOCAL CODE AUTHORITY. THE CONTRACTOR SHALL BE RESPONSIBLE FOR OBTAINING ALL NECESSARY PERMITS AND APPROVALS FROM THE LOCAL CODE AUTHORITY. THE CONTRACTOR SHALL BE RESPONSIBLE FOR OBTAINING ALL NECESSARY PERMITS AND APPROVALS FROM THE LOCAL CODE AUTHORITY.

TYPICAL SINGLE SERVICE CONNECTION

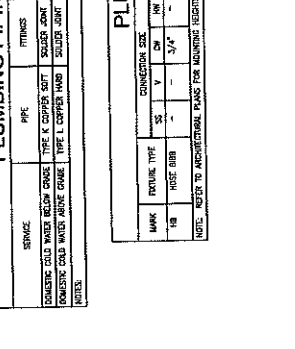

HOSE BIBB DETAIL

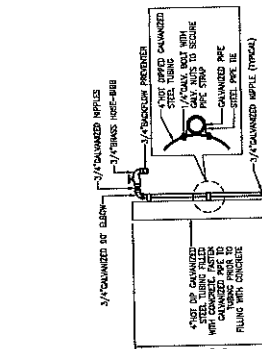

TRENCH DETAIL

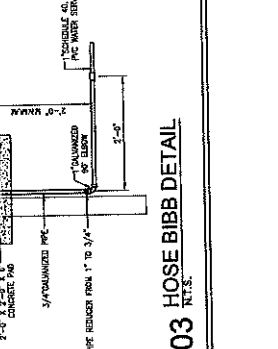

PLUMBING SYSTEM - SECTION

22 00 00  
THE WORK INCLUDES INSTALLATION OF ALL MECHANICAL, ELECTRICAL AND PLUMBING (MEP) SYSTEMS. THE CONTRACTOR SHALL BE RESPONSIBLE FOR VERIFYING THE ACCURACY OF ALL DIMENSIONS AND CONDITIONS AS NOTED ON THE DRAWINGS. THE CONTRACTOR SHALL BE RESPONSIBLE FOR OBTAINING ALL NECESSARY PERMITS AND APPROVALS FROM THE LOCAL CODE AUTHORITY. THE CONTRACTOR SHALL BE RESPONSIBLE FOR OBTAINING ALL NECESSARY PERMITS AND APPROVALS FROM THE LOCAL CODE AUTHORITY.

**01 PLUMBING SITE PLAN**  
 SCALE: 1/8" = 1'-0"

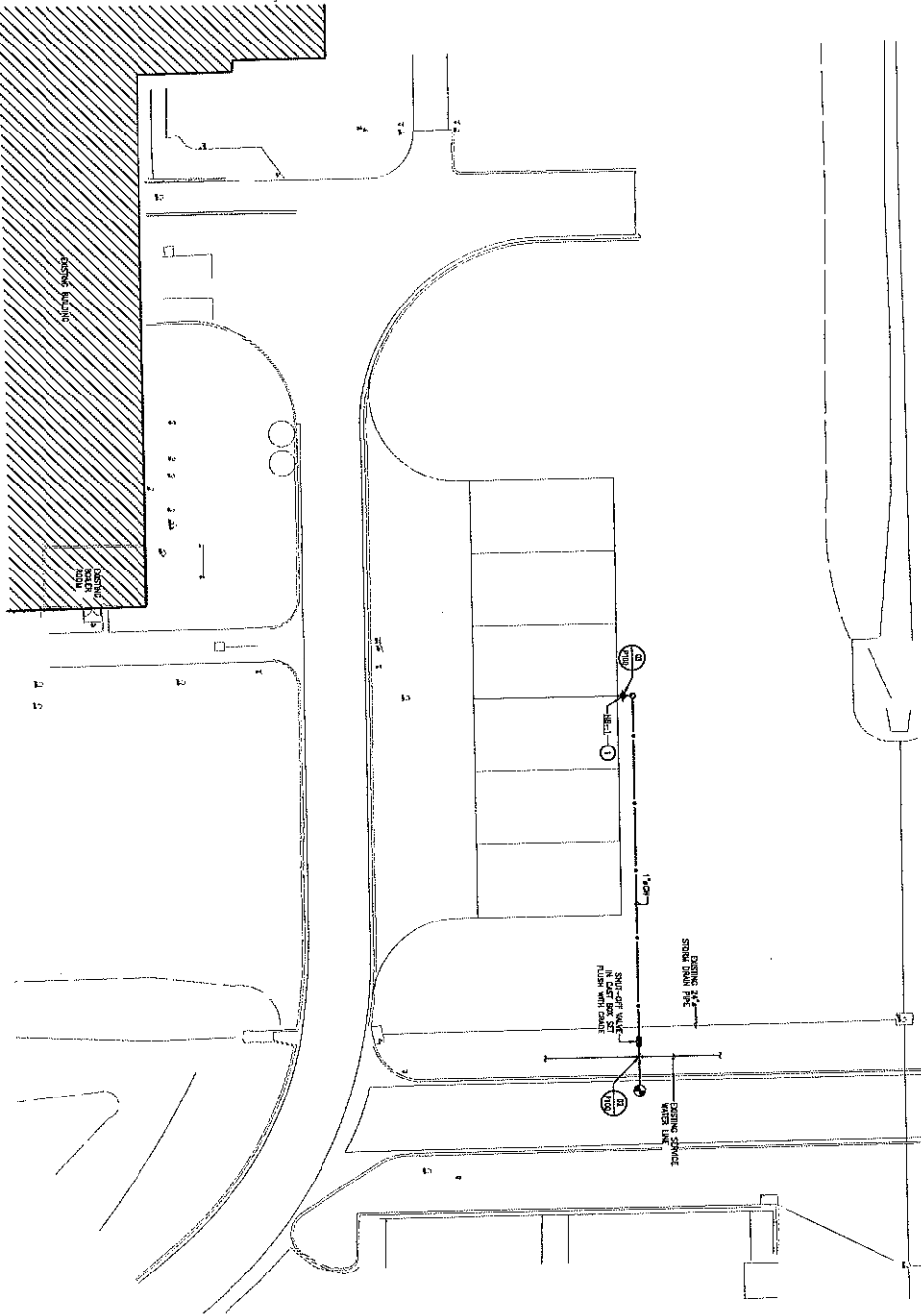

**GENERAL NOTES:**

1. INFORMATION ON THIS PLAN HAS BEEN OBTAINED FROM THE RECORD PLANS AND FIELD SURVEY. THE CONTRACTOR SHALL VERIFY EXISTING CONDITIONS PRIOR TO CONSTRUCTION. ANY DISCREPANCIES SHOULD BE REPORTED IMMEDIATELY TO THE PROVIDER.
2. ALL PLUMBING SHALL BE INSTALLED TO ALL CODES THAT HAVE JURISDICTION OVER THIS PROJECT.
3. PLUMBING CONTRACTOR TO COMPLY WITH ALL APPLICABLE CODES AND REGULATIONS FOR PLUMBING AND ELECTRICAL UNDERGROUND CONDUIT FROM TO EXISTING OF CONSTRUCTION.
4. CONTRACTOR SHALL BE FULLY RESPONSIBLE FOR ALL PLUMBING AND ELECTRICAL WORK.
5. PLUMBING CONTRACTOR SHALL BE RESPONSIBLE FOR ALL WORK TO EXISTING AND RELATED SERVICES.
6. SEWER, ALL EXISTING SHALL REMAIN.
7. EXISTING WATER LINE SHALL BE REMOVED, 24\"/>

**KEY NOTES:**

1. CONTRACTOR SHALL BE RESPONSIBLE FOR OBTAINING ALL NECESSARY PERMITS FROM THE APPROPRIATE AGENCIES.

PROJECT NO.	2017-10-01
DATE	11/15/2017
DESIGNED BY	HALFF
CHECKED BY	HALFF
SCALE	AS SHOWN
SHEET NO.	1
TOTAL SHEETS	1
PROJECT TITLE	PLUMBING SITE PLAN
SHEET NUMBER	P-101



Revision No.	Date	Description

**HALFF**  
 200 WEST MILITARY, SUITE 100  
 AUSTIN, TEXAS 78704  
 TEL: 512.476.1111  
 FAX: 512.476.1112  
 WWW.HALFF.COM



**HCSO BUS BARN**  
 HIDALGO COUNTY CONTRACT  
 #C-18-142-05-08  
 EDINBURG, TX 78541

**SECTION 00 41 00**  
**BID FORM**

**1.01 TO:**

- A. County of Hidalgo  
1. Hidalgo County Purchasing Department, 2802 S. Business Hwy. 281, Edinburg, TX 78539

**1.02 FOR:**

- A. HCSO Bus Barn, Edinburg, TX  
RFB No. #C-18-142-05-08

**1.03 DATE:** \_\_\_\_\_ (Bidder to enter date)

**1.04 SUBMITTED BY:** (Bidder to enter name and address)

- A. Bidder's Full Name \_\_\_\_\_  
Address \_\_\_\_\_  
City, State, Zip \_\_\_\_\_

**1.05 OFFER**

- A. Having examined the Place of The Work and all matters referred to in the Instructions to Bidders and the Contract Documents prepared by Halff Associates, Inc. for the above mentioned project, we, the undersigned, hereby offer to enter into a Contract to perform the Work for the items listed in this bid form of:

\_\_\_\_\_ dollars (\$ \_\_\_\_\_), in lawful money of the United States of America.

- B. **BID BOND:** Offerors will be required to provide Bid Security in the form of a Bid Bond in the amount of 5 percent of the largest possible total proposal. Failure to provide the Bid Bond with the proposal will constitute a non-responsive proposal and the proposal will not be considered.
- C. **PERFORMANCE AND LABOR & MATERIAL PAYMENT BONDS:** The successful Offeror will be required to provide 100% Performance and Labor and Materials. Payment Bond in strict conformance with all the requirements of the Contract Documents. Failure to do so will result in cancellation of the contract award and forfeiture of the Bid Bond security as liquidated damages.
- D. **NOTE:** Awarded Vendor must provide criminal background clearances through Senate Bill 9 for all personnel and sub-contractors working on the project job site.
- E. All applicable federal taxes are included and State of Texas taxes are included in the Bid Sum.

**1.06 ACCEPTANCE**

- A. This Bidder shall be open to acceptance and is irrevocable for Ninety (90) days from the bid closing date.
- B. If this bid is accepted by County of Hidalgo within the time period stated above, we will:  
Execute the Agreement within seven days of receipt of Notice of Award.  
Furnish the required bonds within seven days of receipt of Notice of Award.

Commence work within seven days after written Notice to Proceed of this bid.

- C. If this bid is accepted within the time stated, and we fail to commence the Work or we fail to provide the required Bond(s), the security deposit shall be forfeited as damages to County of Hidalgo by reason of our failure, limited in amount to the lesser of the face value of the security deposit or the difference between this bid and the bid upon which a Contract is signed.
- D. In the event our bid is not accepted within the time stated above, the required security deposit shall be returned to the undersigned, in accordance with the provisions of the Instructions to Bidders; unless a mutually satisfactory arrangement is made for its retention and validity for an extended period of time.

### 1.07 CONTRACT TIME

- A. If the Bid is accepted, project will be substantially complete as follows: Complete the Work in thirty (30) calendar days from Notice to Proceed.
- B. Liquidated Damages: County of Hidalgo has the right under contract to assess liquidated damages for each calendar day beyond the date for substantial completion set out in the contract in which the Work fails to be substantially complete due to unexcused delay. In the event the Contractor fails to achieve Substantial Completion of the work within the time indicated in the Bid Form, or as mutually agreed upon, or as such date may be extended or shortened by approved Change Order, the Owner shall be entitled to liquidated damages in the amount of \$500.00 per day for each day that the work is not substantially complete - the date on the Certificate of Substantial Completion.
- C. In the event the Contractor fails to achieve Final Completion of the Work within ten (10) days of Substantial Completion or as mutually agreed upon, or as such date may be extended or shortened by approved Change Order, the Owner shall be entitled to liquidated damages in the amount of \$500.00 per day that passes within the first seven days past the scheduled Final Completion date in which the Work is not completed; \$1,000.00 per day for each day that passes within the second seven days past the scheduled Final Completion date in which the Work is not completed; and \$1,500.00 per day for each day that passes within the third seven days past the scheduled Final Completion date in which the Work is not completed, until the work is finally completed.
- D. Back Charges: County of Hidalgo has the right under contract to back charge amounts that are spent to complete a portion of the work not completed by the contractor based on schedule and repairs of damage caused by work associated with the construction that requires quick response due to County of Hidalgo operations and contractor has failed to respond. This will be deducted from contractor's contract amount and written as a change order to the contract.
- E. Rain/Off Days: Rain Days must be submitted within 3 days of event or with each pay application (weekly report) failure to provide notification with proper proof within the time period will not be accepted. Any additional days after rain days that the contractor fails to work will be charged as work days unless authorized in writing by both the contractor and Owner, refer to 1.07 Contract Time, A.
- F. Completion of Work  
If this Bid is accepted, we will:  
Complete the Work in 30 calendar days from Notice to Proceed.

### 1.08 CHANGES TO THE WORK

- A. All approved change orders must be signed by the Owner and Engineer. Engineer will issue a Proposal Request (PR) to the Contractor; Contractor will prepare detail cost and time information including sub-

004100 - 2

contractor breakdown (Change Proposal) and submit to Engineer for review, within 10 days of receipt of the Proposed Change; Engineer will submit proposal and all information to Owner for review and approval.

B. Allowances shall be handled in a similar manner as a change order, refer to 1.08, B. Contractor shall prepare detail cost and time information and submit to Engineer for review; Engineer will submit proposal and all information to Owner for review and approval.

**1.09 ADDENDA**

A. The following Addenda have been received. The modifications to the Proposal Documents noted below have been considered and all costs are included in the Proposal Sum.

- \_\_\_ Addendum # 1 Dated \_\_\_\_\_.
- \_\_\_ Addendum # 2 Dated \_\_\_\_\_.
- \_\_\_ Addendum # 3 Dated \_\_\_\_\_.
- \_\_\_ Addendum # 4 Dated \_\_\_\_\_.
- \_\_\_ Addendum # 5 Dated \_\_\_\_\_.

**1.10 BID FORM SIGNATURE(S)**

A. The Corporate Seal of \_\_\_\_\_

B. (Bidder - print the full name of your firm)

C. was hereunto affixed in the presence of:

D. \_\_\_\_\_

E. (Authorized signing officer, Title)

F. (Seal)

G. \_\_\_\_\_

H. (Authorized signing officer, Title)

**1.11 If the Bid is a joint venture or partnership, add additional forms of execution for each member of the joint venture in the appropriate form or forms as above.**

**END OF BID FORM**

**BID SHEET**

**CONSTRUCTION OF BUS BARN FOR HIDALGO COUNTY SHERIFF'S OFFICE  
EDINBURG, TEXAS**

**LOCATION: 711 EL CIBOLO ROAD, EDINBURG TEXAS**

**CONSTRUCTION OF BUS BARN FOR HIDALGO COUNTY SHERIFF'S OFFICE**

	Quantity	Unit	Unit Cost	Cost	
1	BUS BARN IMPROVEMENTS	1	LS	\$ -	\$ -
<b>Sub - Total =</b>				<b>\$ -</b>	<b>\$ -</b>

**Total = \$ -**

**NOTE:**

- ALL ITEMS ARE TO BE PRICED TO BE COMPLETE IN PLACE AND FULLY FUNCTIONAL WITH ALL ASSOCIATED LABOR
- 1 INCLUDED.
- 2 ALL MOBILIZATION, EXPECTED FEES AND PERMITS ARE TO PRICED UNDER VARIES BID ITEMS.
- 3 ALL ITEMS ON PLANS AND SPECIFICATIONS SHALL BE PRICED WITHIN THIS BID FORM.

**STATEMENT OF CREDENTIALS**  
for Facility Construction and Related Projects  
(Non-road Improvements)

**1. GENERAL:** In order to assist the Owner in determining the ability of each Bidder to properly fulfill the requirements of this proposed contract, the Bidder will complete the following items. **All questions must be answered** and the data given must be clear and comprehensive. **This statement must be notarized.** If necessary, questions may be answered on separate attached sheets. The Bidder may submit any additional information he/she desires.

Name of Bidder: \_\_\_\_\_

Address: \_\_\_\_\_

\_\_\_\_\_

Date Organized: \_\_\_\_\_ Date Incorporated: \_\_\_\_\_

Office Number: \_\_\_\_\_ Fax Number: \_\_\_\_\_

Number of years in business under present name: \_\_\_\_\_

Type of work performed by your company: \_\_\_\_\_

\_\_\_\_\_

Have you ever failed to complete any work awarded to you? \_\_\_\_\_

Have you ever defaulted on a contract? \_\_\_\_\_

**2. EXPERIENCE:** The Bidder will give below a list of similar projects which he/she has completed within the last five (5) years.

1. Owner: \_\_\_\_\_

Address: \_\_\_\_\_

Ph/Fx Number: \_\_\_\_\_ Email: \_\_\_\_\_

Scope of Work Description: \_\_\_\_\_

Date Completed: \_\_\_\_\_ Total Cost: \_\_\_\_\_

\*\*\*\*\*

2. Owner: \_\_\_\_\_

Address: \_\_\_\_\_

Ph/Fx Number: \_\_\_\_\_ Email: \_\_\_\_\_

Scope of Work Description: \_\_\_\_\_

Date Completed: \_\_\_\_\_ Total Cost: \_\_\_\_\_

\*\*\*\*\*

3. Owner: \_\_\_\_\_

Address: \_\_\_\_\_

Ph/Fx Number: \_\_\_\_\_ Email: \_\_\_\_\_

Scope of Work Description: \_\_\_\_\_

Date Completed: \_\_\_\_\_ Total Cost: \_\_\_\_\_

\*\*\*\*\*

4. Owner: \_\_\_\_\_

Address: \_\_\_\_\_

Ph/Fx Number: \_\_\_\_\_ Email: \_\_\_\_\_

Scope of Work Description: \_\_\_\_\_

Date Completed: \_\_\_\_\_ Total Cost: \_\_\_\_\_

\*\*\*\*\*

5. Owner: \_\_\_\_\_

Address: \_\_\_\_\_

Ph/Fx Number: \_\_\_\_\_ Email: \_\_\_\_\_

Scope of Work Description: \_\_\_\_\_

Date Completed: \_\_\_\_\_ Total Cost: \_\_\_\_\_

\*\*\*\*\*

3. **CONTRACTS ON HAND:** The Bidder shall provide below a list of any contracts/projects he/she currently has on hand:

---

---

---

---

---

---

---

---

4. **SUBCONTRACTORS:** List any subcontractors you propose to use on the Hidalgo County's project. Use additional page if necessary. This information is considered preliminary and may be revised prior if bid is awarded and re-submitted during the pre-construction phase. However, it is expressly understood that the use of any subcontractor other than those listed with bid shall require written approval from Hidalgo County.

Failure to submit the information as required may result in a disqualification of your bid.

---

---

---

---

---

---

---

---

---

---

---

---

---

---

---

---

---

---

---

---

---

---

5. **PERFORMANCE OF WORK BY BIDDER:** Except as otherwise provided, the **general contractor/bidder** shall perform no **less** than eighty percent (**80%**) of the work with his own organization, and **no more than** twenty percent (**20%**) of the work may be subcontracted.

The organization of the specifications into divisions, sections, articles, etc., and the arrangement and titles of project drawings shall not control the Bidder in dividing the work among subcontractors or in establishing the extent of work to be performed by any trade.

Awarded bidder shall assign a project superintendent who is directly employed by the Bidder, that superintendent will be required to be on the job on a daily basis. No subcontractors will be allowed to act as project superintendents at any point during the construction of said project.

Bidder shall have a significant business presence with the Rio Grande Valley Area, the business must be headquartered in either Hidalgo, Cameron, or Starr County or a local office must be located in either of the three counties (Hidalgo, Cameron, Starr) with at least thirty percent (30%) of the total company workforce employed at the local office. County reserves the right to request payrolls and any necessary documentation to confirm that the local office meets these requirements.

Bidders shall carefully examine the plans, specifications and other documents, visit the site of the work, and fully inform themselves as to all conditions and matters which can affect the work or cost thereof. Should the bidder find discrepancies in, or omissions from the plans, specifications or other documents, or should he/she be in doubt as their meaning, he/she should at once notify the Engineer and obtain clarification by addendum prior to submitting any bid.

Bidder hereby certifies that said company carried liability coverage and workers compensation insurance coverage that meets the requirements set forth in this Request for Bids/Proposals when performing work on this project for Hidalgo County.

Furthermore, bidder certifies that any subcontractor on the project shall provide the said company with a certificate relating that all employees of the subcontractor also are provided with workers' compensation insurance coverage. Bidder will provide copies of all of these certificates to Hidalgo County during the course of the project for all subcontractors working on the project.

All subcontractors must comply with federally determined prevailing Davis-Bacon and Related Acts wage rate.

Hidalgo County encourages the hiring of minority women subcontractors and/or suppliers whenever and wherever feasible.

The undersigned hereby authorizes and requests any person, firm, or corporation to furnish any information requested by the owner in verification of the recitals comprising this Statement of Credentials.

Executed this \_\_\_\_\_ day of \_\_\_\_\_, 20\_\_\_\_\_.

\_\_\_\_\_

By \_\_\_\_\_

Title \_\_\_\_\_

**Subscribed and sworn to me this** \_\_\_\_\_ day of \_\_\_\_\_, 20\_\_\_\_\_.

By: \_\_\_\_\_

Notary Public in and for \_\_\_\_\_ County, Texas

My commission expires \_\_\_\_\_

THIS PAGE LEFT INTENTIONALLY BLANK

THE STATE OF TEXAS §  
§  
COUNTY OF HIDALGO §

**CONSTRUCTION CONTRACT**  
**C-19-267-xx-xx**

This Agreement entered into this \_\_\_day\_\_\_ of 2020, by and between the County of Hidalgo (hereinafter called the "OWNER") and \_\_\_\_\_ (a corporation) (a partnership) (an individual) of \_\_\_\_\_, State of Texas, hereinafter Called "CONTRACTOR". The County's procurement packet and Contractor's response are incorporated herein for all purposes.

**WITNESSETH**

That for and in consideration of the payments and agreement hereinafter mentioned, to be made and performed by the OWNER, the CONTRACTOR hereby agrees with the OWNER to commence and complete the construction described as follows:

**NAME OF PROJECT**

Hereinafter called the project, for the sum of \_\_\_\_\_ and all extra work in connection therewith, under the terms and stated in the General and Special Conditions of the Contract; and at his (its or their) own proper cost and expense to furnish all the materials, supplies, machinery, equipment, tools, superintendence, labor, insurance, and other accessories and services necessary to complete the said project in accordance with the conditions and prices stated in the Proposal, the General Conditions and Special Conditions printed or written explanatory matter thereof, the specifications and contract documents therefore as prepared by \_\_\_\_\_, entitled the Architect/Engineer, and as enumerated in Paragraph 1.01.A.12 of the General Conditions, all of which are made a part hereof and collectively evidence and constitute the contract.

The CONTRACTOR hereby agrees to commence work under this contract on or after a date to be specified in written "Notice to Proceed" of the OWNER and to fully complete the project within \_\_\_\_\_ calendar days thereafter. The CONTRACTOR further agrees to pay, as liquidated damages, the sum of \$ \_\_\_\_\_ for each consecutive calendar day thereafter.

The OWNER agrees to pay the CONTRACTOR in current funds for the performance of the contract, subject to additions and deductions, as provided in the General Conditions of the contract, and to make payments on account thereof as provided in Paragraphs 14.02.C and 14.07.C of the General Conditions.

WITNESS THE HANDS OF THE PARTIES effective as of the day and year first written above.

APPROVED BY COMMISSIONERS COURT ON, \_\_\_\_\_, 2\_\_\_\_\_.

CONTRACTOR: \_\_\_\_\_  
Print Name & Title: \_\_\_\_\_  
Name of Firm: \_\_\_\_\_  
Address: \_\_\_\_\_  
Fed I.D. #/SS #: \_\_\_\_\_

STATE OF TEXAS

COUNTY OF HIDALGO

This instrument was acknowledged before me on this the \_\_\_\_\_ day of \_\_\_\_\_,  
2\_\_\_\_\_, by \_\_\_\_\_ Of and on behalf of \_\_\_\_\_  
(Title) (A corporation)

\_\_\_\_\_  
Notary Public-Signature

ATTEST:

COUNTY OF HIDALGO:

\_\_\_\_\_  
Arturo Guajardo, Jr., County Clerk

\_\_\_\_\_  
Richard F. Cortez, County Judge

APPROVED AS TO FORM:  
Hidalgo County District Attorney's Office

By: \_\_\_\_\_  
Robert Viña III, Assistant District Attorney

**PAYMENT BOND**

(To be used in Texas under V.A.T.S. 5160)

THE STATE OF \_\_\_\_\_

COUNTY OF \_\_\_\_\_

KNOW ALL MEN BY THESE PRESENTS: That we (1) \_\_\_\_\_,  
a (2) \_\_\_\_\_, hereinafter called  
Principal and (3) \_\_\_\_\_ of  
\_\_\_\_\_, hereinafter called the  
Surety, are held and firmly bound unto (4) \_\_\_\_\_ of  
\_\_\_\_\_, hereinafter called Owner, and unto all persons, firms,  
and corporations who may furnish materials for, or perform labor upon the  
building or improvements hereinafter referred to the penal sum of \_\_\_\_\_  
(\$ \_\_\_\_\_) Dollars in lawful money of the United States to be  
paid in (5) \_\_\_\_\_, for the payment of which sum well  
and truly to be made, we bind ourselves, our heirs, executors,  
administrators, and successors, jointly and severally, firmly be these  
presents.

THE CONDITION OF THIS OBLIGATION is such that Whereas, the Principal entered  
into a certain contract with (6) \_\_\_\_\_, the Owner, dated the \_\_\_\_\_ day  
of \_\_\_\_\_, A.D. 200\_\_, a copy of which is hereto attached and made a  
part hereof for the construction of:

**HIDALGO COUNTY PRECINCT # \_\_\_\_\_**

These footnotes refer to numbers in body of contract above:

Date of Bond must not be prior to date of contract

- (1) Correct name of Contractor
- (2) A Corporation, a Partnership or an Individual, as case may be
- (3) Correct name of Surety
- (4) Correct name of Owner
- (5) County and State
- (6) Owner

NOW, THEREFORE, the condition of this obligation is such that, if the -1-  
Principal shall promptly make payment to all claimants as defined in  
Article 5160 Revised Civil Statutes of Texas, 1925, as amended by House  
Bill 344, Act 56<sup>th</sup> Legislature, Regular Session, 1925 effective April 27,  
1959, supplying labor and materials in the prosecution of the work  
provided for in said Contract, then this obligation shall be null and  
void, otherwise it shall remain in full force and effect.

This bond is made and entered into solely for the prosecution of all  
claimants supplying labor and material in the prosecution of the work  
provided for in said Contract, and all such claimants shall have a direct  
right of action under the bond as provided in Article 5160, Revised Civil  
Statutes 1925, as amended by House Bill 344, Acts 56<sup>th</sup> Legislature, Regular  
Session, 1959

PROVIDED FURTHER, that if any legal action be filed upon this bond, venue shall  
lie in Hidalgo County, State of Texas, and that the said surety, for value

received hereby stipulates and agrees that no change, extension of time, alteration or addition to the terms of the contract or to the work to be performed thereunder or the specification accompanying the same shall in any way affect its obligation on this bond, and it does hereby waive notice of any such change, extension of time, alteration or addition to the terms of the contract or to the work or to the specifications.

PROVIDED FURTHER, that no final settlement between the Owner and the Contractor shall abridge the right of any beneficiary hereunder, whose claim may be unsatisfied.

IN WITNESS WHEREOF, this instrument is executed in six counterparts, each one of which shall be deemed an original, this the \_\_\_\_\_ day of \_\_\_\_\_  
\_\_\_\_\_. A.D., 20\_\_\_\_\_.

ATTEST:

\_\_\_\_\_  
(Principal) Secretary

(Seal)

\_\_\_\_\_  
Witness as to Principal

\_\_\_\_\_  
(Address)

Principal \_\_\_\_\_  
By \_\_\_\_\_

(Address) \_\_\_\_\_

Telephone Number: \_\_\_\_\_

\_\_\_\_\_  
Surety

ATTEST:

\_\_\_\_\_  
(Surety) Secretary

(Seal)

\_\_\_\_\_  
Witness as to Surety

\_\_\_\_\_  
(Address)

By \_\_\_\_\_

(Address) \_\_\_\_\_

NOTE: If Contractor is partnership all  
Partners should execute bond

Telephone Number: \_\_\_\_\_

**PAYMENT BOND FORM**

\_\_\_\_\_  
\_\_\_\_\_  
(Address)  
Telephone Number: \_\_\_\_\_

\_\_\_\_\_  
(Individual Principal)  
\_\_\_\_\_  
(Business Address)  
Telephone Number: \_\_\_\_\_

\_\_\_\_\_  
(Corporate Principal)

\_\_\_\_\_  
(Business Address) (Affix Corporate SEAL)  
Telephone Number: \_\_\_\_\_  
BY \_\_\_\_\_

\_\_\_\_\_  
ATTEST:

\_\_\_\_\_  
(Business Address) (Affix Corporate SEAL)  
BY \_\_\_\_\_  
Telephone Number: \_\_\_\_\_

**CERTIFICATES AS TO CORPORATE PRINCIPAL**

I, \_\_\_\_\_, certify that I am the \_\_\_\_\_  
Secretary of the corporation named as Principal in the within bond; that \_\_\_\_\_  
\_\_\_\_\_, who signed the said bond on behalf of the Principal  
was then \_\_\_\_\_ of said corporation; and I know his signature,  
and his signature thereto is genuine; and that said bond was duly signed,  
sealed, and attested for and in behalf of said corporation by authority of  
its governing body.

\_\_\_\_\_  
(TITLE)  
DATE \_\_\_\_\_

\_\_\_\_\_  
(AFFIX CORPORATE SEAL)

Telephone Number: \_\_\_\_\_

The rate of premium on this bond is \_\_\_\_\_ per thousand. Total amount  
of premium charge \$ \_\_\_\_\_.  
(The above must be filled in by corporate surety.) (Power-of-Attorney of  
person signing for surety company must be attached.)

THIS PAGE LEFT INTENTIONALLY BLANK

**PERFORMANCE BOND**

(To be used in Texas under V.A.T.S. 5160)

THE STATE OF \_\_\_\_\_

COUNTY OF \_\_\_\_\_

KNOW ALL MEN BY THESE PRESENTS: That we (1) \_\_\_\_\_, a (2) \_\_\_\_\_ OF \_\_\_\_\_ hereinafter called Principal and (3) \_\_\_\_\_ of \_\_\_\_\_, State of \_\_\_\_\_, hereinafter called the Surety, are held and firmly bound unto (4) \_\_\_\_\_ of \_\_\_\_\_, hereinafter called Owner, in the penal sum of \_\_\_\_\_ (\$ \_\_\_\_\_) Dollars in lawful money of the United States to be paid in (5) \_\_\_\_\_, for the payment of which sum well and truly to be made, we bind ourselves, our heirs, executors, administrators, and successors, jointly and severally, firmly be these presents.

THE CONDITION OF THIS OBLIGATION is such that Whereas, the Principal entered into a certain contract with (6) \_\_\_\_\_, the Owner, dated the \_\_\_\_\_ day of \_\_\_\_\_, A.D. 200\_\_, a copy of which is hereto attached and made a part hereof for the construction of:

**HIDALGO COUNTY PRECINCT # \_\_\_\_\_**

hereinafter called the "Work").

These footnotes refer to the numbers in body of contract above:

Date of Bond must not be prior to date of contract

- (1) Correct name of Contractor
- (2) A Corporation, a Partnership or an Individual, as case may be
- (3) Correct name of Surety
- (4) Correct name of Owner
- (5) County and State
- (6) Owner

(Texas Performance Bond) - Page 2.

NOW, THEREFORE, if the Principal shall well, truly and faithfully perform the work in accordance with the plans, specifications, and contract documents during the original term thereof, and any extensions thereof which may be granted by the Owner, with or without notice to the Surety, and if he shall satisfy all claims and demands incurred under such contract, and shall fully indemnify and save harmless the Owner from all costs and damages which it may suffer by reason of failure to do so, and shall reimburse and repay the Owner all outlay and expense which the Owner may incur in making good any default, then this obligation shall be void; otherwise to remain in full force and effect.

PROVIDED FURTHER, that if any legal action be filed upon this bond, venue shall lie in Hidalgo County, State of Texas, and that the said surety, for value received hereby stipulates and agrees that no change, extension of time, alteration or addition to the terms of the contract or to the work to be performed thereunder or the specifications accompanying the same shall in any

way affect its obligation on this bond, and it does hereby waive notice of any such change, extension of time, alternation or addition to the terms of the contract or to the work or to the specifications.

IN WITNESS WHEREOF, this instrument is executed in six counterparts, each one of which shall be deemed an original, this the \_\_\_\_\_ day of \_\_\_\_\_ . A.D.

ATTEST:

\_\_\_\_\_  
(Principal) Secretary

(Seal)

\_\_\_\_\_  
Witness as to Principal

\_\_\_\_\_  
(Address)

Principal \_\_\_\_\_  
By \_\_\_\_\_

(Address) \_\_\_\_\_

Telephone Number: \_\_\_\_\_

ATTEST:

\_\_\_\_\_  
(Surety) Secretary

(Seal)

\_\_\_\_\_  
Witness as to Surety

\_\_\_\_\_  
(Address)

By \_\_\_\_\_

(Address) \_\_\_\_\_

Telephone Number: \_\_\_\_\_

NOTE: If Contractor is a partnership, all partners should execute bond.

**PERFORMANCE-PAYMENT BOND FORM**

\_\_\_\_\_  
(Address)  
Telephone Number: \_\_\_\_\_

\_\_\_\_\_  
(Individual Principal)  
\_\_\_\_\_  
(Business Address)  
Telephone Number: \_\_\_\_\_

\_\_\_\_\_  
(Corporate Principal)

\_\_\_\_\_  
(Business Address) (Affix Corporate SEAL)  
Telephone Number: \_\_\_\_\_  
BY \_\_\_\_\_

\_\_\_\_\_  
ATTEST:

\_\_\_\_\_  
\_\_\_\_\_

\_\_\_\_\_  
(Business Address) (Affix Corporate SEAL)  
BY \_\_\_\_\_  
Telephone Number: \_\_\_\_\_

**CERTIFICATES AS TO CORPORATE PRINCIPAL**

I, \_\_\_\_\_, certify that I am the \_\_\_\_\_  
Secretary of the corporation named as Principal in the within bond; that \_\_\_\_\_  
\_\_\_\_\_, who signed the said bond on behalf of the Principal  
was then \_\_\_\_\_ of said corporation; and I know his signature,  
and his signature thereto is genuine; and that said bond was duly signed,  
sealed, and attested for and in behalf of said corporation by authority of  
its governing body.

\_\_\_\_\_  
(TITLE)  
DATE \_\_\_\_\_

\_\_\_\_\_  
(AFFIX CORPORATE SEAL)

Telephone Number: \_\_\_\_\_

The rate of premium on this bond is \_\_\_\_\_ per thousand. Total amount  
of premium charge \$ \_\_\_\_\_.  
(The above must be filled in by corporate surety.) (Power-of-Attorney of  
person signing for surety company must be attached.)

STANDARD  
GENERAL CONDITIONS  
OF THE  
CONSTRUCTION CONTRACT

Prepared by

ENGINEERS JOINT CONTRACT DOCUMENTS COMMITTEE

and

Issued and Published Jointly By

PROFESSIONAL ENGINEERS IN PRIVATE PRACTICE  
*a practice division of the*  
NATIONAL SOCIETY OF PROFESSIONAL ENGINEERS

---

AMERICAN CONSULTING ENGINEERS COUNCIL

---

AMERICAN SOCIETY OF CIVIL ENGINEERS

This document has been approved and endorsed by

The Associated General

Contractors of America

Construction Specifications Institute

Copyright ©1996

National Society of Professional Engineers  
1420 King Street, Alexandria, VA 22314

American Consulting Engineers Council  
1015 15th Street N.W., Washington, DC 20005

American Society of Civil Engineers  
345 East 47th Street, New York, NY 10017

**TABLE OF CONTENTS**

	<u>Page</u>
ARTICLE 1 - DEFINITIONS AND TERMINOLOGY .....	6
1.01 <i>Defined Terms</i> .....	6
1.02 <i>Terminology</i> .....	8
ARTICLE 2 - PRELIMINARY MATTERS .....	9
2.01 <i>Delivery of Bonds</i> .....	9
2.02 <i>Copies of Documents</i> .....	9
2.03 <i>Commencement of Contract Times; Notice to Proceed</i> .....	9
2.04 <i>Starting the Work</i> .....	9
2.05 <i>Before Starting Construction</i> .....	9
2.06 <i>Preconstruction Conference</i> .....	10
2.07 <i>Initial Acceptance of Schedules</i> .....	10
ARTICLE 3 - CONTRACT DOCUMENTS: INTENT, AMENDING, REUSE.....	10
3.01 <i>Intent</i> .....	10
3.02 <i>Reference Standards</i> .....	10
3.03 <i>Reporting and Resolving Discrepancies</i> .....	10
3.04 <i>Amending and Supplementing Contract Documents</i> .....	11
3.05 <i>Reuse of Documents</i> .....	11
ARTICLE 4 - AVAILABILITY OF LANDS; SUBSURFACE AND PHYSICAL CONDITIONS; REFERENCE POINTS.....	11
4.01 <i>Availability of Lands</i> .....	11
4.02 <i>Subsurface and Physical Conditions</i> .....	12
4.03 <i>Differing Subsurface or Physical Conditions</i> .....	12
4.04 <i>Underground Facilities</i> .....	13
4.05 <i>Reference Points</i> .....	13
4.06 <i>Hazardous Environmental Condition at Site</i> .....	14
ARTICLE 5 - BONDS AND INSURANCE.....	15
5.01 <i>Performance, Payment, and Other Bonds</i> .....	15
5.02 <i>Licensed Sureties and Insurers</i> .....	15
5.03 <i>Certificates of Insurance</i> .....	15
5.04 <i>CONTRACTOR's Liability Insurance</i> .....	15
5.05 <i>OWNER's Liability Insurance</i> .....	16
5.06 <i>Property Insurance</i> .....	16
5.07 <i>Waiver of Rights</i> .....	17
5.08 <i>Receipt and Application of Insurance Proceeds</i> .....	18
5.09 <i>Acceptance of Bonds and Insurance; Option to Replace</i> .....	18
5.10 <i>Partial Utilization, Acknowledgment of Property Insurer</i> .....	18
ARTICLE 6 - CONTRACTOR'S RESPONSIBILITIES .....	18
6.01 <i>Supervision and Superintendence</i> .....	18
6.02 <i>Labor; Working Hours</i> .....	19
6.03 <i>Services, Materials, and Equipment</i> .....	19
6.04 <i>Progress Schedule</i> .....	19
6.05 <i>Substitutes and "Or-Equals"</i> .....	19
6.06 <i>Concerning Subcontractors, Suppliers, and Others</i> .....	21

6.07 Patent Fees and Royalties .....	21
6.08 Permits .....	22
6.09 Laws and Regulations .....	22
6.10 Taxes .....	22
6.11 Use of Site and Other Areas .....	22
6.12 Record Documents .....	22
6.13 Safety and Protection .....	23
6.14 Safety Representative .....	23
6.15 Hazard Communication Programs .....	23
6.16 Emergencies .....	23
6.17 Shop Drawings and Samples .....	24
6.18 Continuing the Work .....	25
6.19 CONTRACTOR's General Warranty and Guarantee .....	25
6.20 Indemnification .....	25
ARTICLE 7 - OTHER WORK .....	26
7.01 Related Work at Site .....	26
7.02 Coordination .....	26
ARTICLE 8 - OWNER'S RESPONSIBILITIES .....	27
8.01 Communications to Contractor .....	27
8.02 Replacement of ENGINEER .....	27
8.03 Furnish Data .....	27
8.04 Pay Promptly When Due .....	27
8.05 Lands and Easements; Reports and Tests .....	27
8.06 Insurance .....	27
8.07 Change Orders .....	27
8.08 Inspections, Tests, and Approvals .....	27
8.09 Limitations on OWNER's Responsibilities .....	27
8.10 Undisclosed Hazardous Environmental Condition .....	27
8.11 Evidence of Financial Arrangements .....	27
ARTICLE 9 - ENGINEER'S STATUS DURING CONSTRUCTION .....	27
9.01 OWNER'S Representative .....	27
9.02 Visits to Site .....	28
9.03 Project Representative .....	28
9.04 Clarifications and Interpretations .....	28
9.05 Authorized Variations in Work .....	28
9.06 Rejecting Defective Work .....	29
9.07 Shop Drawings, Change Orders and Payments .....	29
9.08 Determinations for Unit Price Work .....	28
9.09 Decisions on Requirements of Contract Documents and Acceptability of Work .....	28
9.10 Limitations on ENGINEER's Authority and Responsibilities .....	28
ARTICLE 10 - CHANGES IN THE WORK; CLAIMS .....	29
10.01 Authorized Changes in the Work .....	29
10.02 Unauthorized Changes in the Work .....	29
10.03 Execution of Change Orders .....	30
10.04 Notification to Surety .....	30
10.05 Claims and Disputes .....	30
ARTICLE 11 - COST OF THE WORK; CASH ALLOWANCES; UNIT PRICE WORK .....	30
11.01 Cost of the Work .....	30

11.02 Cash Allowances .....	32
11.03 Unit Price Work .....	33
ARTICLE 12 - CHANGE OF CONTRACT PRICE; CHANGE OF CONTRACT TIMES.....	33
12.01 Change of Contract Price .....	33
12.02 Change of Contract Times .....	34
12.03 Delays Beyond CONTRACTOR's Control.....	34
12.04 Delays Within CONTRACTOR's Control .....	34
12.05 Delays Beyond OWNER's and CONTRACTOR'S Control.....	34
12.06 Delay Damages .....	34
ARTICLE 13 - TESTS AND INSPECTIONS; CORRECTION, REMOVAL OR ACCEPTANCE OF DEFECTIVE WORK.....	34
13.01 Notice of Defects .....	34
13.02 Access to Work .....	34
13.03 Tests and Inspections.....	35
13.04 Uncovering Work.....	35
13.05 OWNER May Stop the Work .....	35
13.06 Correction or Removal of Defective Work .....	36
13.07 Correction Period .....	36
13.08 Acceptance of Defective Work .....	36
13.09 OWNER May Correct Defective Work.....	36
ARTICLE 14 - PAYMENTS TO CONTRACTOR AND COMPLETION .....	37
14.01 Schedule of Values .....	37
14.02 Progress Payments .....	37
14.03 CONTRACTOR's Warranty of Title .....	38
14.04 Substantial Completion .....	39
14.05 Partial Utilization .....	39
14.06 Final Inspection.....	39
14.07 Final Payment.....	40
14.08 Final Completion Delayed.....	40
14.09 Waiver of Claims.....	41
ARTICLE 15 - SUSPENSION OF WORK AND TERMINATION.....	41
15.01 OWNER May Suspend Work .....	41
15.02 OWNER May Terminate for Cause .....	41
15.03 OWNER May Terminate For Convenience .....	41
15.04 CONTRACTOR May Stop Work or Terminate.....	42
ARTICLE 16 - DISPUTE RESOLUTION .....	42
16.01 Methods and Procedures .....	42
ARTICLE 17 - MISCELLANEOUS.....	43
17.01 Giving Notice .....	43
17.02 Computation of Times .....	43
17.03 Cumulative Remedies.....	43
17.04 Survival of Obligations .....	43
17.05 Controlling Law .....	43

## GENERAL CONDITIONS

### ARTICLE 1 - DEFINITIONS AND TERMINOLOGY

---

#### 1.01 *Defined Terms*

A. Wherever used in the Contract Documents and printed with initial or all capital letters, the terms listed below will have the meanings indicated which are applicable to both the singular and plural thereof.

1. *Addenda*--Written or graphic instruments issued prior to the opening of Bids which clarify, correct, or change the Bidding Requirements or the Contract Documents.

2. *Agreement*--The written instrument which is evidence of the agreement between OWNER and CONTRACTOR covering the Work.

3. *Application for Payment*--The form acceptable to ENGINEER which is to be used by CONTRACTOR during the course of the Work in requesting progress or final payments and which is to be accompanied by such supporting documentation as is required by the Contract Documents.

4. *Asbestos*--Any material that contains more than one percent asbestos and is friable or is releasing asbestos fibers into the air above current action levels established by the United States Occupational Safety and Health Administration.

5. *Bid*--The offer or proposal of a bidder submitted on the prescribed form setting forth the prices for the Work to be performed.

6. *Bidding Documents*--The Bidding Requirements and the proposed Contract Documents (including all Addenda issued prior to receipt of Bids).

7. *Bidding Requirements*--The Advertisement or Invitation to Bid, Instructions to Bidders, Bid security form, if any, and the Bid form with any supplements.

8. *Bonds*--Performance and payment bonds and other instruments of security.

9. *Change Order*--A document recommended by ENGINEER which is signed by CONTRACTOR and OWNER and authorizes an addition, deletion, or revision in the Work or an adjustment in the Contract Price or the

Contract Times, issued on or after the Effective Date of the Agreement.

10. *Claim*--A demand or assertion by OWNER or CONTRACTOR seeking an adjustment of Contract Price or Contract Times, or both, or other relief with respect to the terms of the Contract. A demand for money or services by a third party is not a Claim.

11. *Contract*--The entire and integrated written agreement between the OWNER and CONTRACTOR concerning the Work. The Contract supersedes prior negotiations, representations, or agreements, whether written or oral.

12. *Contract Documents*--The Contract Documents establish the rights and obligations of the parties and include the Agreement, Addenda (which pertain to the Contract Documents), CONTRACTOR's Bid (including documentation accompanying the Bid and any post Bid documentation submitted prior to the Notice of Award) when attached as an exhibit to the Agreement, the Notice to Proceed, the Bonds, these General Conditions, the Supplementary Conditions, the Specifications and the Drawings as the same are more specifically identified in the Agreement, together with all Written Amendments, Change Orders, Work Change Directives, Field Orders, and ENGINEER's written interpretations and clarifications issued on or after the Effective Date of the Agreement. Approved Shop Drawings and the reports and drawings of subsurface and physical conditions are not Contract Documents. Only printed or hard copies of the items listed in this paragraph are Contract Documents. Files in electronic media format of text, data, graphics, and the like that may be furnished by OWNER to CONTRACTOR are not Contract Documents.

13. *Contract Price*--The moneys payable by OWNER to CONTRACTOR for completion of the Work in accordance with the Contract Documents as stated in the Agreement (subject to the provisions of paragraph 11.03 in the case of Unit Price Work).

14. *Contract Times*--The number of days or the dates stated in the Agreement to: (i) achieve Substantial Completion; and (ii) complete the Work so that it is ready for final payment as evidenced by ENGINEER's written recommendation of final payment.

15. *CONTRACTOR*--The individual or entity with whom OWNER has entered into the Agreement.

16. *Cost of the Work*--See paragraph 11.01.A for definition.

17. *Drawings*--That part of the Contract Documents prepared or approved by ENGINEER which graphically shows the scope, extent, and character of the Work to be performed by CONTRACTOR. Shop Drawings and other CONTRACTOR submittals are not Drawings as so defined.

18. *Effective Date of the Agreement*--The date indicated in the Agreement on which it becomes effective, but if no such date is indicated, it means the date on which the Agreement is signed and delivered by the last of the two parties to sign and deliver.

19. *ENGINEER*--The individual or entity named as such in the Agreement.

20. *ENGINEER's Consultant*--An individual or entity having a contract with ENGINEER to furnish services as ENGINEER's independent professional associate or consultant with respect to the Project and who is identified as such in the Supplementary Conditions.

21. *Field Order*--A written order issued by ENGINEER which requires minor changes in the Work but which does not involve a change in the Contract Price or the Contract Times.

22. *General Requirements*--Sections of Division 1 of the Specifications. The General Requirements pertain to all sections of the Specifications.

23. *Hazardous Environmental Condition*--The presence at the Site of Asbestos, PCBs, Petroleum, Hazardous Waste, or Radioactive Material in such quantities or circumstances that may present a substantial danger to persons or property exposed thereto in connection with the Work.

24. *Hazardous Waste*--The term Hazardous Waste shall have the meaning provided in Section 1004 of the Solid Waste Disposal Act (42 USC Section 6903) as amended from time to time.

25. *Laws and Regulations; Laws or Regulations*--Any and all applicable laws, rules, regulations, ordinances, codes, and orders of any and all governmental bodies, agencies, authorities, and courts having jurisdiction.

26. *Liens*--Charges, security interests, or encumbrances upon Project funds, real property, or personal property.

27. *Milestone*--A principal event specified in the Contract Documents relating to an intermediate completion date or time prior to Substantial Completion of all the Work.

28. *Notice of Award*--The written notice by OWNER to the apparent successful bidder stating that upon timely compliance by the apparent successful bidder with the conditions precedent listed therein, OWNER will sign and deliver the Agreement.

29. *Notice to Proceed*--A written notice given by OWNER to CONTRACTOR fixing the date on which the Contract Times will commence to run and on which CONTRACTOR shall start to perform the Work under the Contract Documents.

30. *OWNER*--The individual, entity, public body, or authority with whom CONTRACTOR has entered into the Agreement and for whom the Work is to be performed.

31. *Partial Utilization*--Use by OWNER of a substantially completed part of the Work for the purpose for which it is intended (or a related purpose) prior to Substantial Completion of all the Work.

32. *PCBs*--Polychlorinated biphenyls.

33. *Petroleum*--Petroleum, including crude oil or any fraction thereof which is liquid at standard conditions of temperature and pressure (60 degrees Fahrenheit and 14.7 pounds per square inch absolute), such as oil, petroleum, fuel oil, oil sludge, oil refuse, gasoline, kerosene, and oil mixed with other non-Hazardous Waste and crude oils.

34. *Project*--The total construction of which the Work to be performed under the Contract Documents may be the whole, or a part as may be indicated elsewhere in the Contract Documents.

35. *Project Manual*--The bound documentary information prepared for bidding and constructing the Work. A listing of the contents of the Project Manual, which may be bound in one or more volumes, is contained in the table(s) of contents.

36. *Radioactive Material*--Source, special nuclear, or byproduct material as defined by the Atomic Energy Act of 1954 (42 USC Section 2011 et seq.) as amended from time to time.

37. *Resident Project Representative*--The authorized representative of ENGINEER who may be assigned to the Site or any part thereof.

38. *Samples*--Physical examples of materials, equipment, or workmanship that are representative of some portion of the Work and which establish the standards by which such portion of the Work will be judged.

39. *Shop Drawings*--All drawings, diagrams, illustrations, schedules, and other data or information which are specifically prepared or assembled by or for CONTRACTOR and submitted by CONTRACTOR to illustrate some portion of the Work.

40. *Site*--Lands or areas indicated in the Contract Documents as being furnished by OWNER upon which the Work is to be performed, including rights-of-way and easements for access thereto, and such other lands furnished by OWNER which are designated for the use of CONTRACTOR.

41. *Specifications*--That part of the Contract Documents consisting of written technical descriptions of materials, equipment, systems, standards, and workmanship as applied to the Work and certain administrative details applicable thereto.

42. *Subcontractor*--An individual or entity having a direct contract with CONTRACTOR or with any other Subcontractor for the performance of a part of the Work at the Site.

43. *Substantial Completion*--The time at which the Work (or a specified part thereof) has progressed to the point where, in the opinion of ENGINEER, the Work (or a specified part thereof) is sufficiently complete, in accordance with the Contract Documents, so that the Work (or a specified part thereof) can be utilized for the purposes for which it is intended. The terms "substantially complete" and "substantially completed" as applied to all or part of the Work refer to Substantial Completion thereof.

44. *Supplementary Conditions*--That part of the Contract Documents which amends or supplements these General Conditions.

45. *Supplier*--A manufacturer, fabricator, supplier, distributor, materialman, or vendor having a direct contract with CONTRACTOR or with any Subcontractor to furnish materials or equipment to be incorporated in the Work by CONTRACTOR or any Subcontractor.

46. *Underground Facilities*--All underground pipelines, conduits, ducts, cables, wires, manholes, vaults, tanks, tunnels, or other such facilities or attachments, and any encasements containing such facilities, including those that convey electricity, gases, steam, liquid petroleum products, telephone or other communications, cable television, water, wastewater, storm water, other liquids or chemicals, or traffic or other control systems.

47. *Unit Price Work*--Work to be paid for on the basis of unit prices.

48. *Work*--The entire completed construction or the various separately identifiable parts thereof required to be provided under the Contract Documents. Work includes and is the result of performing or providing all labor, services, and documentation necessary to produce such construction, and furnishing, installing, and incorporating all materials and equipment into such construction, all as required by the Contract Documents.

49. *Work Change Directive*--A written statement to CONTRACTOR issued on or after the Effective Date of the Agreement and signed by OWNER and recommended by ENGINEER ordering an addition, deletion, or revision in the Work, or responding to differing or unforeseen subsurface or physical conditions under which the Work is to be performed or to emergencies. A Work Change Directive will not change the Contract Price or the Contract Times but is evidence that the parties expect that the change ordered or documented by a Work Change Directive will be incorporated in a subsequently issued Change Order following negotiations by the parties as to its effect, if any, on the Contract Price or Contract Times.

50. *Written Amendment*--A written statement modifying the Contract Documents, signed by OWNER and CONTRACTOR on or after the Effective Date of the Agreement and normally dealing with the nonengineering or nontechnical rather than strictly construction-related aspects of the Contract Documents.

## 1.02 Terminology

### A. Intent of Certain Terms or Adjectives

1. Whenever in the Contract Documents the terms "as allowed," "as approved," or terms of like effect or import are used, or the adjectives "reasonable," "suitable," "acceptable," "proper," "satisfactory," or adjectives of like effect or import are used to describe an action or determination of ENGINEER as to the Work, it is intended that such action or determination will be solely to evaluate, in general, the completed Work for compliance with the requirements of and information in the Contract Documents and conformance with the design concept of the completed Project as a functioning whole as shown or indicated in the Contract Documents (unless there is a specific statement indicating otherwise). The use of any such term or adjective shall not be effective to assign to ENGINEER any duty or authority to supervise or direct the performance of the Work or any duty or authority to undertake responsibility contrary to the provisions of paragraph 9.10 or any other provision of the Contract Documents.

### B. Day

1. The word "day" shall constitute a calendar day of 24 hours measured from midnight to the next midnight.

### C. Defective

1. The word "defective," when modifying the word "Work," refers to Work that is unsatisfactory, faulty, or deficient in that it does not conform to the Contract Documents or does not meet the requirements of any inspection, reference standard, test, or approval referred to in the Contract Documents, or has been damaged prior to ENGINEER's recommendation of final payment (unless responsibility for the protection thereof has been assumed by OWNER at Substantial Completion in accordance with paragraph 14.04 or 14.05).

### D. Furnish, Install, Perform, Provide

1. The word "furnish," when used in connection with services, materials, or equipment, shall mean to supply and deliver said services, materials, or equipment to the Site (or some other

specified location) ready for use or installation and in usable or operable condition.

2. The word "install," when used in connection with services, materials, or equipment, shall mean to put into use or place in final position said services, materials, or equipment complete and ready for intended use.

3. The words "perform" or "provide," when used in connection with services, materials, or equipment, shall mean to furnish and install said services, materials, or equipment complete and ready for intended use.

4. When "furnish," "install," "perform," or "provide" is not used in connection with services, materials, or equipment in a context clearly requiring an obligation of CONTRACTOR, "provide" is implied.

E. Unless stated otherwise in the Contract Documents, words or phrases which have a well-known technical or construction industry or trade meaning are used in the Contract Documents in accordance with such recognized meaning.

## ARTICLE 2 - PRELIMINARY MATTERS

---

### 2.01 Delivery of Bonds

A. When CONTRACTOR delivers the executed Agreements to OWNER, CONTRACTOR shall also deliver to OWNER such Bonds as CONTRACTOR may be required to furnish.

### 2.02 Copies of Documents

A. OWNER shall furnish to CONTRACTOR up to ten copies of the Contract Documents. Additional copies will be furnished upon request at the cost of reproduction.

### 2.03 Commencement of Contract Times; Notice to Proceed

A. The Contract Times will commence to run on the thirtieth day after the Effective Date of the Agreement or, if a Notice to Proceed is given, on the day indicated in the Notice to Proceed. A Notice to Proceed may be given at any time within 30 days after the Effective Date of the Agreement. In no event will the Contract Times com-

mence to run later than the sixtieth day after the day of Bid opening or the thirtieth day after the Effective Date of the Agreement, whichever date is earlier.

#### 2.04 *Starting the Work*

A. CONTRACTOR shall start to perform the Work on the date when the Contract Times commence to run. No Work shall be done at the Site prior to the date on which the Contract Times commence to run.

#### 2.05 *Before Starting Construction*

A. *CONTRACTOR's Review of Contract Documents:* Before undertaking each part of the Work, CONTRACTOR shall carefully study and compare the Contract Documents and check and verify pertinent figures therein and all applicable field measurements. CONTRACTOR shall promptly report in writing to ENGINEER any conflict, error, ambiguity, or discrepancy which CONTRACTOR may discover and shall obtain a written interpretation or clarification from ENGINEER before proceeding with any Work affected thereby; however, CONTRACTOR shall not be liable to OWNER or ENGINEER for failure to report any conflict, error, ambiguity, or discrepancy in the Contract Documents unless CONTRACTOR knew or reasonably should have known thereof.

B. *Preliminary Schedules:* Within ten days after the Effective Date of the Agreement (unless otherwise specified in the General Requirements), CONTRACTOR shall submit to ENGINEER for its timely review:

1. a preliminary progress schedule indicating the times (numbers of days or dates) for starting and completing the various stages of the Work, including any Milestones specified in the Contract Documents;
2. a preliminary schedule of Shop Drawing and Sample submittals which will list each required submittal and the times for submitting, reviewing, and processing such submittal; and
3. a preliminary schedule of values for all of the Work which includes quantities and prices of items which when added together equal the Contract Price and subdivides the Work into

component parts in sufficient detail to serve as the basis for progress payments during performance of the Work. Such prices will include an appropriate amount of overhead and profit applicable to each item of Work.

C. *Evidence of Insurance:* Before any Work at the Site is started, CONTRACTOR and OWNER shall each deliver to the other, with copies to each additional insured identified in the Supplementary Conditions, certificates of insurance (and other evidence of insurance which either of them or any additional insured may reasonably request) which CONTRACTOR and OWNER respectively are required to purchase and maintain in accordance with Article 5.

#### 2.06 *Preconstruction Conference*

A. Within 20 days after the Contract Times start to run, but before any Work at the Site is started, a conference attended by CONTRACTOR, ENGINEER, and others as appropriate will be held to establish a working understanding among the parties as to the Work and to discuss the schedules referred to in paragraph 2.05.B, procedures for handling Shop Drawings and other submittals, processing Applications for Payment, and maintaining required records.

#### 2.07 *Initial Acceptance of Schedules*

A. Unless otherwise provided in the Contract Documents, at least ten days before submission of the first Application for Payment a conference attended by CONTRACTOR, ENGINEER, and others as appropriate will be held to review for acceptability to ENGINEER as provided below the schedules submitted in accordance with paragraph 2.05.B. CONTRACTOR shall have an additional ten days to make corrections and adjustments and to complete and resubmit the schedules. No progress payment shall be made to CONTRACTOR until acceptable schedules are submitted to ENGINEER.

1. The progress schedule will be acceptable to ENGINEER if it provides an orderly progression of the Work to completion within any specified Milestones and the Contract Times. Such acceptance will not impose on ENGINEER responsibility for the progress schedule, for sequencing, scheduling, or progress of the Work nor interfere with or relieve CONTRACTOR from CONTRACTOR's full responsibility therefor.

2. CONTRACTOR's schedule of Shop Drawing and Sample submittals will be acceptable to ENGINEER if it provides a workable arrangement for reviewing and processing the required submittals.

3. CONTRACTOR's schedule of values will be acceptable to ENGINEER as to form and substance if it provides a reasonable allocation of the Contract Price to component parts of the Work.

### ARTICLE 3 - CONTRACT DOCUMENTS: INTENT, AMENDING, REUSE

#### 3.01 *Intent*

A. The Contract Documents are complementary; what is called for by one is as binding as if called for by all.

B. It is the intent of the Contract Documents to describe a functionally complete Project (or part thereof) to be constructed in accordance with the Contract Documents. Any labor, documentation, services, materials, or equipment that may reasonably be inferred from the Contract Documents or from prevailing custom or trade usage as being required to produce the intended result will be provided whether or not specifically called for at no additional cost to OWNER.

C. Clarifications and interpretations of the Contract Documents shall be issued by ENGINEER as provided in Article 9.

#### 3.02 *Reference Standards*

##### *A. Standards, Specifications, Codes, Laws, and Regulations*

1. Reference to standards, specifications, manuals, or codes of any technical society, organization, or association, or to Laws or Regulations, whether such reference be specific or by implication, shall mean the standard, specification, manual, code, or Laws or Regulations in effect at the time of opening of Bids (or on the Effective Date of the Agreement if there were no Bids), except as may be otherwise specifically stated in the Contract Documents.

2. No provision of any such standard, specification, manual or code, or any instruction of a Supplier shall be effective to change the duties or responsibilities of OWNER, CONTRACTOR, or ENGINEER, or any of their subcontractors, consultants, agents, or employees from those set forth in the Contract Documents, nor shall any such provision or instruction be effective to assign to OWNER, ENGINEER, or any of ENGINEER's Consultants, agents, or employees any duty or authority to supervise or direct the performance of the Work or any duty or authority to undertake responsibility inconsistent with the provisions of the Contract Documents.

#### 3.03 *Reporting and Resolving Discrepancies*

##### *A. Reporting Discrepancies*

1. If, during the performance of the Work, CONTRACTOR discovers any conflict, error, ambiguity, or discrepancy within the Contract Documents or between the Contract Documents and any provision of any Law or Regulation applicable to the performance of the Work or of any standard, specification, manual or code, or of any instruction of any Supplier, CONTRACTOR shall report it to ENGINEER in writing at once. CONTRACTOR shall not proceed with the Work affected thereby (except in an emergency as required by paragraph 6.16.A) until an amendment or supplement to the Contract Documents has been issued by one of the methods indicated in paragraph 3.04; provided, however, that CONTRACTOR shall not be liable to OWNER or ENGINEER for failure to report any such conflict, error, ambiguity, or discrepancy unless CONTRACTOR knew or reasonably should have known thereof.

##### *B. Resolving Discrepancies*

1. Except as may be otherwise specifically stated in the Contract Documents, the provisions of the Contract Documents shall take precedence in resolving any conflict, error, ambiguity, or discrepancy between the provisions of the Contract Documents and:

a. the provisions of any standard, specification, manual, code, or instruction (whether or not specifically incorporated by reference in the Contract Documents); or

b. the provisions of any Laws or Regulations applicable to the performance of the Work (unless such an interpretation of the provisions of the Contract Documents would result in violation of such Law or Regulation).

### 3.04 *Amending and Supplementing Contract Documents*

A. The Contract Documents may be amended to provide for additions, deletions, and revisions in the Work or to modify the terms and conditions thereof in one or

B. The requirements of the Contract Documents may be supplemented, and minor variations and deviations in the Work may be authorized, by one or more of the following ways: (i) a Field Order; (ii) ENGINEER's approval of a Shop Drawing or Sample; or (iii) ENGINEER's written interpretation or clarification.

### 3.05 *Reuse of Documents*

A. CONTRACTOR and any Subcontractor or Supplier or other individual or entity performing or furnishing any of the Work under a direct or indirect contract with OWNER: (i) shall not have or acquire any title to or ownership rights in any of the Drawings, Specifications, or other documents (or copies of any thereof) prepared by or bearing the seal of ENGINEER or ENGINEER's Consultant, including electronic media editions; and (ii) shall not reuse any of such Drawings, Specifications, other documents, or copies thereof on extensions of the Project or any other project without written consent of OWNER and ENGINEER and specific written verification or adaption by ENGINEER. This prohibition will survive final payment, completion, and acceptance of the Work, or termination or completion of the Contract. Nothing herein shall preclude CONTRACTOR from retaining copies of the Contract Documents for record purposes.

## ARTICLE 4 - AVAILABILITY OF LANDS; SUBSURFACE AND PHYSICAL CONDITIONS; REFERENCE POINTS

### 4.01 *Availability of Lands*

A. OWNER shall furnish the Site. OWNER shall notify CONTRACTOR of any encumbrances or

restrictions not of general application but specifically related to use of the Site with which CONTRACTOR must comply in performing the Work. OWNER will obtain in a timely manner and pay for easements for permanent structures or permanent changes in existing facilities. If CONTRACTOR and OWNER are unable to agree on entitlement to or on the amount or extent, if any, of any adjustment in the Contract Price or Contract Times, or both, as a result of any delay in OWNER's furnishing the Site, CONTRACTOR may make a Claim therefor as provided in paragraph 10.05.

B. Upon reasonable written request, OWNER shall furnish CONTRACTOR with a current statement of record legal title and legal description of the lands upon which the Work is to be performed and OWNER's interest therein as necessary for giving notice of or filing a mechanic's or construction lien against such lands in accordance with applicable Laws and Regulations.

C. CONTRACTOR shall provide for all additional lands and access thereto that may be required for temporary construction facilities or storage of materials and equipment.

### 4.02 *Subsurface and Physical Conditions*

A. *Reports and Drawings:* The Supplementary Conditions identify:

1. those reports of explorations and tests of subsurface conditions at or contiguous to the Site that ENGINEER has used in preparing the Contract Documents; and

2. those drawings of physical conditions in or relating to existing surface or subsurface structures at or contiguous to the Site (except Underground Facilities) that ENGINEER has used in preparing the Contract Documents.

B. *Limited Reliance by CONTRACTOR on Technical Data Authorized:* CONTRACTOR may rely upon the general accuracy of the "technical data" contained in such reports and drawings, but such reports and drawings are not Contract Documents. Such "technical data" is identified in the Supplementary Conditions. Except for such reliance on such "technical data," CONTRACTOR may not rely upon or make any Claim against OWNER, ENGINEER, or any of ENGINEER's Consultants with respect to:

1. the completeness of such reports and drawings for CONTRACTOR's purposes, includ-

ing, but not limited to, any aspects of the means, methods, techniques, sequences, and procedures of construction to be employed by CONTRACTOR, and safety precautions and programs incident thereto; or

2. other data, interpretations, opinions, and information contained in such reports or shown or indicated in such drawings; or

3. any CONTRACTOR interpretation of or conclusion drawn from any "technical data" or any such other data, interpretations, opinions, or information.

#### 4.03 Differing Subsurface or Physical Conditions

A. *Notice:* If CONTRACTOR believes that any subsurface or physical condition at or contiguous to the Site that is uncovered or revealed either:

1. is of such a nature as to establish that any "technical data" on which CONTRACTOR is entitled to rely as provided in paragraph 4.02 is materially inaccurate; or

2. is of such a nature as to require a change in the Contract Documents; or

3. differs materially from that shown or indicated in the Contract Documents; or

4. is of an unusual nature, and differs materially from conditions ordinarily encountered and generally recognized as inherent in work of the character provided for in the Contract Documents; then CONTRACTOR shall, promptly after becoming aware thereof and before further disturbing the subsurface or physical conditions or performing any Work in connection therewith (except in an emergency as required by paragraph 6.16.A), notify OWNER and ENGINEER in writing about such condition. CONTRACTOR shall not further disturb such condition or perform any Work in connection therewith (except as aforesaid) until receipt of written order to do so.

B. *ENGINEER's Review:* After receipt of written notice as required by paragraph 4.03.A, ENGINEER will promptly review the pertinent condition, determine the

necessity of OWNER's obtaining additional exploration or tests with respect thereto, and advise OWNER in writing (with a copy to CONTRACTOR) of ENGINEER's findings and conclusions.

#### C. Possible Price and Times Adjustments

1. The Contract Price or the Contract Times, or both, will be equitably adjusted to the extent that the existence of such differing subsurface or physical condition causes an increase or decrease in CONTRACTOR's cost of, or time required for, performance of the Work; subject, however, to the following:

a. such condition must meet any one or more of the categories described in paragraph 4.03.A; and

b. with respect to Work that is paid for on a Unit Price Basis, any adjustment in Contract Price will be subject to the provisions of paragraphs 9.08 and 11.03.

2. CONTRACTOR shall not be entitled to any adjustment in the Contract Price or Contract Times if:

a. CONTRACTOR knew of the existence of such conditions at the time CONTRACTOR made a final commitment to OWNER in respect of Contract Price and Contract Times by the submission of a Bid or becoming bound under a negotiated contract; or

b. the existence of such condition could reasonably have been discovered or revealed as a result of any examination, investigation, exploration, test, or study of the Site and contiguous areas required by the Bidding Requirements or Contract Documents to be conducted by or for CONTRACTOR prior to CONTRACTOR's making such final commitment; or

c. CONTRACTOR failed to give the written notice within the time and as required by paragraph 4.03.A.

3. If OWNER and CONTRACTOR are unable to agree on entitlement to or on the amount or extent, if any, of any adjustment in the Contract Price or Contract Times, or both, a Claim may be

made therefor as provided in paragraph 10.05. However, OWNER, ENGINEER, and ENGINEER's Consultants shall not be liable to CONTRACTOR for any claims, costs, losses, or damages (including but not limited to all fees and charges of engineers, architects, attorneys, and other professionals and all court or arbitration or other dispute resolution costs) sustained by CONTRACTOR on or in connection with any other project or anticipated project.

#### 4.04 *Underground Facilities*

A. *Shown or Indicated:* The information and data shown or indicated in the Contract Documents with respect to existing Underground Facilities at or contiguous to the Site is based on information and data furnished to OWNER or ENGINEER by the owners of such Underground Facilities, including OWNER, or by others. Unless it is otherwise expressly provided in the Supplementary Conditions:

1. OWNER and ENGINEER shall not be responsible for the accuracy or completeness of any such information or data; and

2. the cost of all of the following will be included in the Contract Price, and CONTRACTOR shall have full responsibility for:

a. reviewing and checking all such information and data,

b. locating all Underground Facilities shown or indicated in the Contract Documents,

c. coordination of the Work with the owners of such Underground Facilities, including OWNER, during construction, and

d. the safety and protection of all such Underground Facilities and repairing any damage thereto resulting from the Work.

#### B. *Not Shown or Indicated*

1. If an Underground Facility is uncovered or revealed at or contiguous to the Site which was not shown or indicated, or not shown or indicated with reasonable accuracy in the Contract Documents, CONTRACTOR shall, promptly after becoming aware thereof and before further disturbing conditions affected thereby or

performing any Work in connection therewith (except in an emergency as required by paragraph 6.16.A), identify the owner of such Underground Facility and give written notice to that owner and to OWNER and ENGINEER. ENGINEER will promptly review the Underground Facility and determine the extent, if any, to which a change is required in the Contract Documents to reflect and document the consequences of the existence or location of the Underground Facility. During such time, CONTRACTOR shall be responsible for the safety and protection of such Underground Facility.

2. IF ENGINEER concludes that a change in the Contract Documents is required, a Work Change Directive or a Change Order will be issued to reflect and document such consequences. An equitable adjustment shall be made in the Contract Price of Contract Times, or both, to the extent that they are attributable to the existence or location of any Underground Facility that was not shown or indicated or not shown or indicated with reasonable accuracy in the Contract Documents and that CONTRACTOR did not know of and could not reasonably have been expected to be aware of or to have anticipated. If OWNER and CONTRACTOR are unable to agree on entitlement to or on the amount or extent, if any, of any such adjustment in Contract Price or Contract Times, OWNER or CONTRACTOR may make a Claim therefor as provided in paragraph 10.05.

#### 4.05 *Reference Points*

A. OWNER shall provide engineering surveys to establish reference points for construction which in ENGINEER's judgment are necessary to enable CONTRACTOR to proceed with the Work. CONTRACTOR shall be responsible for laying out the Work, shall protect and preserve the established reference points and property monuments, and shall make no changes or relocations without the prior written approval of OWNER. CONTRACTOR shall report to ENGINEER whenever any reference point or property monument is lost or destroyed or requires relocation because of necessary changes in grades or locations, and shall be responsible for the accurate replacement or relocation of such reference points or property monuments by professionally qualified personnel.

#### 4.06 *Hazardous Environmental Condition at Site*

A. *Reports and Drawings*: Reference is made to the Supplementary Conditions for the identification of those reports and drawings relating to a Hazardous Environmental Condition identified at the Site, if any, that have been utilized by the ENGINEER in the preparation of the Contract Documents.

B. *Limited Reliance by CONTRACTOR on Technical Data Authorized*: CONTRACTOR may rely upon the general accuracy of the "technical data" contained in such reports and drawings, but such reports and drawings are not Contract Documents. Such "technical data" is identified in the Supplementary Conditions. Except for such reliance on such "technical data," CONTRACTOR may not rely upon or make any Claim against OWNER, ENGINEER or any of ENGINEER's Consultants with respect to:

1. the completeness of such reports and drawings for CONTRACTOR's purposes, including, but not limited to, any aspects of the means, methods, techniques, sequences and procedures of construction to be employed by CONTRACTOR and safety precautions and programs incident thereto; or
2. other data, interpretations, opinions and information contained in such reports or shown or indicated in such drawings; or
3. any CONTRACTOR interpretation of or conclusion drawn from any "technical data" or any such other data, interpretations, opinions or information.

C. CONTRACTOR shall not be responsible for any Hazardous Environmental Condition uncovered or revealed at the Site which was not shown or indicated in Drawings or Specifications or identified in the Contract Documents to be within the scope of the Work. CONTRACTOR shall be responsible for a Hazardous Environmental Condition created with any materials brought to the Site by CONTRACTOR, Subcontractors, Suppliers, or anyone else for whom CONTRACTOR is responsible.

D. If CONTRACTOR encounters a Hazardous Environmental Condition or if CONTRACTOR or anyone for whom CONTRACTOR is responsible creates a Hazardous Environmental Condition, CONTRACTOR shall immediately: (i) secure or otherwise isolate such condition;

(ii) stop all Work in connection with such condition and in any area affected thereby (except in an emergency as required by paragraph 6.16); and (iii) notify OWNER and ENGINEER (and promptly thereafter confirm such notice in writing). OWNER shall promptly consult with ENGINEER concerning the necessity for OWNER to retain a qualified expert to evaluate such condition or take corrective action, if any.

E. CONTRACTOR shall not be required to resume Work in connection with such condition or in any affected area until after OWNER has obtained any required permits related thereto and delivered to CONTRACTOR written notice: (i) specifying that such condition and any affected area is or has been rendered safe for the resumption of Work; or (ii) specifying any special conditions under which such Work may be resumed safely. If OWNER and CONTRACTOR cannot agree as to entitlement to or on the amount or extent, if any, of any adjustment in Contract Price or Contract Times, or both, as a result of such Work stoppage or such special conditions under which Work is agreed to be resumed by CONTRACTOR, either party may make a Claim therefor as provided in paragraph 10.05.

F. If after receipt of such written notice CONTRACTOR does not agree to resume such Work based on a reasonable belief it is unsafe, or does not agree to resume such Work under such special conditions, then OWNER may order the portion of the Work that is in the area affected by such condition to be deleted from the Work. If OWNER and CONTRACTOR cannot agree as to entitlement to or on the amount or extent, if any, of an adjustment in Contract Price or Contract Times as a result of deleting such portion of the Work, then either party may make a Claim therefor as provided in paragraph 10.05.

OWNER may have such deleted portion of the Work performed by OWNER's own forces or others in accordance with Article 7.

G. To the fullest extent permitted by Laws and Regulations, OWNER shall indemnify and hold harmless CONTRACTOR, Subcontractors, ENGINEER, ENGINEER's Consultants and the officers, directors, partners, employees, agents, other consultants, and subcontractors of each and any of them from and against all claims, costs, losses, and damages (including but not limited to all fees and charges of engineers, architects, attorneys, and other professionals and all court or arbitration or other dispute resolution costs) arising out of or relating to a Hazardous Environmental Condition, provided that such Hazardous Environmental Condition: (i) was not shown or indicated in the Drawings or

Specifications or identified in the Contract Documents to be included within the scope of the Work, and (ii) was not created by CONTRACTOR or by anyone for whom CONTRACTOR is responsible. Nothing in this paragraph 4.06.E shall obligate OWNER to indemnify any individual or entity from and against the consequences of that individual's or entity's own negligence.

H. To the fullest extent permitted by Laws and Regulations, CONTRACTOR shall indemnify and hold harmless OWNER, ENGINEER, ENGINEER's Consultants, and the officers, directors, partners, employees, agents, other consultants, and subcontractors of each and any of them from and against all claims, costs, losses, and damages (including but not limited to all fees and charges of engineers, architects, attorneys, and other professionals and all court or arbitration or other dispute resolution costs) arising out of or relating to a Hazardous Environmental Condition created by CONTRACTOR or by anyone for whom CONTRACTOR is responsible. Nothing in this paragraph 4.06.F shall obligate CONTRACTOR to indemnify any individual or entity from and against the consequences of that individual's or entity's own negligence.

I. The provisions of paragraphs 4.02, 4.03, and 4.04 are not intended to apply to a Hazardous Environmental Condition uncovered or revealed at the Site.

## ARTICLE 5 - BONDS AND INSURANCE

### 5.01 *Performance, Payment, and Other Bonds*

A. CONTRACTOR shall furnish performance and payment Bonds, each in an amount at least equal to the Contract Price as security for the faithful performance and payment of all CONTRACTOR's obligations under the Contract Documents. These Bonds shall remain in effect at least until one year after the date when final payment becomes due, except as provided otherwise by Laws or Regulations or by the Contract Documents. CONTRACTOR shall also furnish such other Bonds as are required by the Contract Documents.

B. All Bonds shall be in the form prescribed by the Contract Documents except as provided otherwise by Laws or Regulations, and shall be executed by such sureties as are named in the current list of "Companies Holding Certificates of Authority as Acceptable Sureties on Federal Bonds and as Acceptable Reinsuring Compa-

nies" as published in Circular 570 (amended) by the Financial Management Service, Surety Bond Branch, U.S. Department of the Treasury. All Bonds signed by an agent must be accompanied by a certified copy of such agent's authority to act.

C. If the surety on any Bond furnished by CONTRACTOR is declared bankrupt or becomes insolvent or its right to do business is terminated in any state where any part of the Project is located or it ceases to meet the requirements of paragraph 5.01.B, CONTRACTOR shall within 20 days thereafter substitute another Bond and surety, both of which shall comply with the requirements of paragraphs 5.01.B and 5.02.

### 5.02 *Licensed Sureties and Insurers*

A. All Bonds and insurance required by the Contract Documents to be purchased and maintained by OWNER or CONTRACTOR shall be obtained from surety or insurance companies that are duly licensed or authorized in the jurisdiction in which the Project is located to issue Bonds or insurance policies for the limits and coverages so required. Such surety and insurance companies shall also meet such additional requirements and qualifications as may be provided in the Supplementary Conditions.

### 5.03 *Certificates of Insurance*

A. CONTRACTOR shall deliver to OWNER, with copies to each additional insured identified in the Supplementary Conditions, certificates of insurance (and other evidence of insurance requested by OWNER or any other additional insured) which CONTRACTOR is required to purchase and maintain. OWNER shall deliver to CONTRACTOR, with copies to each additional insured identified in the Supplementary Conditions, certificates of insurance (and other evidence of insurance requested by CONTRACTOR or any other additional insured) which OWNER is required to purchase and maintain.

### 5.04 *CONTRACTOR's Liability Insurance*

A. CONTRACTOR shall purchase and maintain such liability and other insurance as is appropriate for the Work being performed and as will provide protection from claims set forth below which may arise out of or result from CONTRACTOR's performance of the Work and CONTRACTOR's other obligations under the Contract Documents, whether it is to be performed by CONTRACTOR, any Subcontractor or Supplier, or by anyone directly or indirectly employed by any of them to

perform any of the Work, or by anyone for whose acts any of them may be liable:

1. claims under workers' compensation, disability benefits, and other similar employee benefit acts;
2. claims for damages because of bodily injury, occupational sickness or disease, or death of CONTRACTOR's employees;
3. claims for damages because of bodily injury, sickness or disease, or death of any person other than CONTRACTOR's employees;
4. claims for damages insured by reasonably available personal injury liability coverage which are sustained: (i) by any person as a result of an offense directly or indirectly related to the employment of such person by CONTRACTOR, or (ii) by any other person for any other reason;
5. claims for damages, other than to the Work itself, because of injury to or destruction of tangible property wherever located, including loss of use resulting therefrom; and
6. claims for damages because of bodily injury or death of any person or property damage arising out of the ownership, maintenance or use of any motor vehicle.

B. The policies of insurance so required by this paragraph 5.04 to be purchased and maintained shall:

1. with respect to insurance required by paragraphs 5.04.A.3 through 5.04.A.6 inclusive, include as additional insureds (subject to any customary exclusion in respect of professional liability) OWNER, ENGINEER, ENGINEER's Consultants, and any other individuals or entities identified in the Supplementary Conditions, all of whom shall be listed as additional insureds, and include coverage for the respective officers, directors, partners, employees, agents, and other consultants and subcontractors of each and any of all such additional insureds, and the insurance afforded to these additional insureds shall provide primary coverage for all claims covered thereby;

2. include at least the specific coverages and be written for not less than the limits of liability provided in the Supplementary Conditions or required by Laws or Regulations, whichever is greater;

3. include completed operations insurance;

4. include contractual liability insurance covering CONTRACTOR's indemnity obligations under paragraphs 6.07, 6.11, and 6.20;

5. contain a provision or endorsement that the coverage afforded will not be canceled, materially changed or renewal refused until at least thirty days prior written notice has been given to OWNER and CONTRACTOR and to each other additional insured identified in the Supplementary Conditions to whom a certificate of insurance has been issued (and the certificates of insurance furnished by the CONTRACTOR pursuant to paragraph 5.03 will so provide);

6. remain in effect at least until final payment and at all times thereafter when CONTRACTOR may be correcting, removing, or replacing defective Work in accordance with paragraph 13.07; and

7. with respect to completed operations insurance, and any insurance coverage written on a claims-made basis, remain in effect for at least two years after final payment (and CONTRACTOR shall furnish OWNER and each other additional insured identified in the Supplementary Conditions, to whom a certificate of insurance has been issued, evidence satisfactory to OWNER and any such additional insured of continuation of such insurance at final payment and one year thereafter).

#### 5.05 *OWNER's Liability Insurance*

A. In addition to the insurance required to be provided by CONTRACTOR under paragraph 5.04, OWNER, at OWNER's option, may purchase and maintain at OWNER's expense OWNER's own liability insurance as will protect OWNER against claims which may arise from operations under the Contract Documents.

#### 5.06 *Property Insurance*

A. Unless otherwise provided in the Supplementary Conditions, OWNER shall purchase and maintain property

insurance upon the Work at the Site in the amount of the full replacement cost thereof (subject to such deductible amounts as may be provided in the Supplementary Conditions or required by Laws and Regulations). This insurance shall:

1. include the interests of OWNER, CONTRACTOR, Subcontractors, ENGINEER, ENGINEER's Consultants, and any other individuals or entities identified in the Supplementary Conditions, and the officers, directors, partners, employees, agents, and other consultants and subcontractors of each and any of them, each of whom is deemed to have an insurable interest and shall be listed as an additional insured;

2. be written on a Builder's Risk "all-risk" or open peril or special causes of loss policy form that shall at least include insurance for physical loss or damage to the Work, temporary buildings, false work, and materials and equipment in transit, and shall insure against at least the following perils or causes of loss: fire, lightning, extended coverage, theft, vandalism and malicious mischief, earthquake, collapse, debris removal, demolition occasioned by enforcement of Laws and Regulations, water damage, and such other perils or causes of loss as may be specifically required by the Supplementary Conditions;

3. include expenses incurred in the repair or replacement of any insured property (including but not limited to fees and charges of engineers and architects);

4. cover materials and equipment stored at the Site or at another location that was agreed to in writing by OWNER prior to being incorporated in the Work, provided that such materials and equipment have been included in an Application for Payment recommended by ENGINEER;

5. allow for partial utilization of the Work by OWNER;

6. include testing and startup; and

7. be maintained in effect until final payment is made unless otherwise agreed to in writing by OWNER, CONTRACTOR, and ENGINEER with

30 days written notice to each other additional insured to whom a certificate of insurance has been issued.

B. OWNER shall purchase and maintain such boiler and machinery insurance or additional property insurance as may be required by the Supplementary Conditions or Laws and Regulations which will include the interests of OWNER, CONTRACTOR, Subcontractors, ENGINEER, ENGINEER's Consultants, and any other individuals or entities identified in the Supplementary Conditions, each of whom is deemed to have an insurable interest and shall be listed as an insured or additional insured.

C. All the policies of insurance (and the certificates or other evidence thereof) required to be purchased and maintained in accordance with paragraph 5.06 will contain a provision or endorsement that the coverage afforded will not be canceled or materially changed or renewal refused until at least 30 days prior written notice has been given to OWNER and CONTRACTOR and to each other additional insured to whom a certificate of insurance has been issued and will contain waiver provisions in accordance with paragraph 5.07.

D. OWNER shall not be responsible for purchasing and maintaining any property insurance specified in this paragraph 5.06 to protect the interests of CONTRACTOR, Subcontractors, or others in the Work to the extent of any deductible amounts that are identified in the Supplementary Conditions. The risk of loss within such identified deductible amount will be borne by CONTRACTOR, Subcontractors, or others suffering any such loss, and if any of them wishes property insurance coverage within the limits of such amounts, each may purchase and maintain it at the purchaser's own expense.

E. If CONTRACTOR requests in writing that other special insurance be included in the property insurance policies provided under paragraph 5.06, OWNER shall, if possible, include such insurance, and the cost thereof will be charged to CONTRACTOR by appropriate Change Order or Written Amendment. Prior to commencement of the Work at the Site, OWNER shall in writing advise CONTRACTOR whether or not such other insurance has been procured by OWNER.

#### 5.07 Waiver of Rights

A. OWNER and CONTRACTOR intend that all policies purchased in accordance with paragraph 5.06 will protect OWNER, CONTRACTOR, Subcontractors, ENGINEER, ENGINEER's Consultants, and all other

individuals or entities identified in the Supplementary Conditions to be listed as insureds or additional insureds (and the officers, directors, partners, employees, agents, and other consultants and subcontractors of each and any of them) in such policies and will provide primary coverage for all losses and damages caused by the perils or causes of loss covered thereby. All such policies shall contain provisions to the effect that in the event of payment of any loss or damage the insurers will have no rights of recovery against any of the insureds or additional insureds thereunder. OWNER and CONTRACTOR waive all rights against each other and their respective officers, directors, partners, employees, agents, and other consultants and subcontractors of each and any of them for all losses and damages caused by, arising out of or resulting from any of the perils or causes of loss covered by such policies and any other property insurance applicable to the Work; and, in addition, waive all such rights against Subcontractors, ENGINEER, ENGINEER's Consultants, and all other individuals or entities identified in the Supplementary Conditions to be listed as insureds or additional insureds (and the officers, directors, partners, employees, agents, and other consultants and subcontractors of each and any of them) under such policies for losses and damages so caused.

None of the above waivers shall extend to the rights that any party making such waiver may have to the proceeds of insurance held by OWNER as trustee or otherwise payable under any policy so issued.

B. OWNER waives all rights against CONTRACTOR, Subcontractors, ENGINEER, ENGINEER's Consultants, and the officers, directors, partners, employees, agents, and other consultants and subcontractors of each and any of them for:

1. loss due to business interruption, loss of use, or other consequential loss extending beyond direct physical loss or damage to OWNER's property or the Work caused by, arising out of, or resulting from fire or other peril whether or not insured by OWNER; and

2. loss or damage to the completed Project or part thereof caused by, arising out of, or resulting from fire or other insured peril or cause of loss covered by any property insurance maintained on the completed Project or part thereof by OWNER during partial utilization pursuant to

paragraph 14.05, after Substantial Completion pursuant to paragraph 14.04, or after final payment pursuant to paragraph 14.07.

C. Any insurance policy maintained by OWNER covering any loss, damage or consequential loss referred to in paragraph 5.07.B shall contain provisions to the effect that in the event of payment of any such loss, damage, or consequential loss, the insurers will have no rights of recovery against CONTRACTOR, Subcontractors, ENGINEER, or ENGINEER's Consultants and the officers, directors, partners, employees, agents, and other consultants and subcontractors of each and any of them.

#### 5.08 *Receipt and Application of Insurance Proceeds*

A.\* Any insured loss under the policies of insurance required by paragraph 5.06 will be adjusted with OWNER and made payable to OWNER as fiduciary for the insureds, as their interests may appear, subject to the requirements of any applicable mortgage clause and of paragraph 5.08.B. OWNER shall deposit in a separate account any money so received and shall distribute it in accordance with such agreement as the parties in interest may reach. If no other special agreement is reached, the damaged Work shall be repaired or replaced, the moneys so received applied on account thereof, and the Work and the cost thereof covered by an appropriate Change Order or Written Amendment.

B. OWNER as fiduciary shall have power to adjust and settle any loss with the insurers unless one of the parties in interest shall object in writing within 15 days after the occurrence of loss to OWNER's exercise of this power. If such objection be made, OWNER as fiduciary shall make settlement with the insurers in accordance with such agreement as the parties in interest may reach. If no such agreement among the parties in interest is reached, OWNER as fiduciary shall adjust and settle the loss with the insurers and, if required in writing by any party in interest, OWNER as fiduciary shall give bond for the proper performance of such duties.

#### 5.09 *Acceptance of Bonds and Insurance; Option to Replace*

A.\* If either OWNER or CONTRACTOR has any objection to the coverage afforded by or other provisions of the Bonds or insurance required to be purchased and maintained by the other party in accordance with Article 5 on the basis of non-conformance with the Contract Documents, the objecting party shall so notify the other party in writing within 10 days after receipt of the

certificates (or other evidence requested) required by paragraph 2.05.C. OWNER and CONTRACTOR shall each provide to the other such additional information in respect of insurance provided as the other may reasonably request. If either party does not purchase or maintain all of the Bonds and insurance required of such party by the Contract Documents, such party shall notify the other party in writing of such failure to purchase prior to the start of the Work, or of such failure to maintain prior to any change in the required coverage. Without prejudice to any other right or remedy, the other party may elect to obtain equivalent Bonds or insurance to protect such other party's interests at the expense of the party who was required to provide such coverage, and a Change Order shall be issued to adjust the Contract Price accordingly.

#### 5.10 *Partial Utilization, Acknowledgment of Property Insurer*

A. If OWNER finds it necessary to occupy or use a portion or portions of the Work prior to Substantial Completion of all the Work as provided in paragraph 14.05, no such use or occupancy shall commence before the insurers providing the property insurance pursuant to paragraph 5.06 have acknowledged notice thereof and in writing effected any changes in coverage necessitated thereby. The insurers providing the property insurance shall consent by endorsement on the policy or policies, but the property insurance shall not be canceled or permitted to lapse on account of any such partial use or occupancy.

### ARTICLE 6 - CONTRACTOR'S RESPONSIBILITIES

---

#### 6.01 *Supervision and Superintendence*

A. CONTRACTOR shall supervise, inspect, and direct the Work competently and efficiently, devoting such attention thereto and applying such skills and expertise as may be necessary to perform the Work in accordance with

the Contract Documents. CONTRACTOR shall be solely responsible for the means, methods, techniques, sequences, and procedures of construction, but CONTRACTOR shall not be responsible for the negligence of OWNER or ENGINEER in the design or specification of a specific means, method, technique, sequence, or procedure of

construction which is shown or indicated in and expressly required by the Contract Documents. CONTRACTOR shall be responsible to see that the completed Work complies accurately with the Contract Documents.

B. At all times during the progress of the Work, CONTRACTOR shall assign a competent resident superintendent thereto who shall not be replaced without written notice to OWNER and ENGINEER except under extraordinary circumstances. The superintendent will be CONTRACTOR's representative at the Site and shall have authority to act on behalf of CONTRACTOR. All communications given to or received from the superintendent shall be binding on CONTRACTOR.

#### 6.02 *Labor; Working Hours*

A. CONTRACTOR shall provide competent, suitably qualified personnel to survey, lay out, and construct the

Work as required by the Contract Documents. CONTRACTOR shall at all times maintain good discipline and order at the Site.

B. Except as otherwise required for the safety or protection of persons or the Work or property at the Site or adjacent thereto, and except as otherwise stated in the Contract Documents, all Work at the Site shall be performed during regular working hours, and CONTRACTOR will not permit overtime work or the performance of Work on Saturday, Sunday, or any legal holiday without OWNER's written consent (which will not be unreasonably withheld) given after prior written notice to ENGINEER.

#### 6.03 *Services, Materials, and Equipment*

A. Unless otherwise specified in the General Requirements, CONTRACTOR shall provide and assume full responsibility for all services, materials, equipment, labor, transportation, construction equipment and machinery, tools, appliances, fuel, power, light, heat, telephone, water, sanitary facilities, temporary facilities, and all other facilities and incidentals necessary for the performance, testing, start-up, and completion of the Work.

B. All materials and equipment incorporated into the Work shall be as specified or, if not specified, shall be of good quality and new, except as otherwise provided in the Contract Documents. All warranties and guarantees specifically called for by the Specifications shall expressly

run to the benefit of OWNER. If required by ENGINEER, CONTRACTOR shall furnish satisfactory evidence (including reports of required tests) as to the source, kind, and quality of materials and equipment. All materials and equipment shall be stored, applied, installed, connected, erected, protected, used, cleaned, and conditioned in accordance with instructions of the applicable Supplier, except as otherwise may be provided in the Contract Documents.

#### 6.04 *Progress Schedule*

A. CONTRACTOR shall adhere to the progress schedule established in accordance with paragraph 2.07 as it may be adjusted from time to time as provided below.

1. CONTRACTOR shall submit to ENGINEER for acceptance (to the extent indicated in paragraph 2.07) proposed adjustments in the progress schedule that will not result in changing the Contract Times (or Milestones). Such adjustments will conform generally to the progress schedule then in effect and additionally will comply with any provisions of the General Requirements applicable thereto.

2. Proposed adjustments in the progress schedule that will change the Contract Times (or Milestones) shall be submitted in accordance with the requirements of Article 12. Such adjustments may only be made by a Change Order or Written Amendment in accordance with Article 12.

#### 6.05 *Substitutes and "Or-Equals"*

A. Whenever an item of material or equipment is specified or described in the Contract Documents by using the name of a proprietary item or the name of a particular Supplier, the specification or description is intended to establish the type, function, appearance, and quality required. Unless the specification or description contains or is followed by words reading that no like, equivalent, or "or-equal" item or no substitution is permitted, other items of material or equipment or material or equipment of other Suppliers may be submitted to ENGINEER for review under the circumstances described below.

1. *"Or-Equal" Items:* If in ENGINEER's sole discretion an item of material or equipment proposed by CONTRACTOR is functionally equal to that named and sufficiently similar so that no change in related Work will be required, it may be

considered by ENGINEER as an "or-equal" item, in which case review and approval of the proposed item may, in ENGINEER's sole discretion, be accomplished without compliance with some or all of the requirements for approval of proposed substitute items. For the purposes of this paragraph 6.05.A.1, a proposed item of material or equipment will be considered functionally equal to an item so named if:

a. in the exercise of reasonable judgment ENGINEER determines that: (i) it is at least equal in quality, durability, appearance, strength, and design characteristics; (ii) it will reliably perform at least equally well the function imposed by the design concept of the completed Project as a functioning whole, and;

b. CONTRACTOR certifies that: (i) there is no increase in cost to the OWNER; and (ii) it will conform substantially, even with deviations, to the detailed requirements of the item named in the Contract Documents.

#### 2. *Substitute Items*

a. If in ENGINEER's sole discretion an item of material or equipment proposed by CONTRACTOR does not qualify as an "or-equal" item under paragraph 6.05.A.1, it will be considered a proposed substitute item.

b. CONTRACTOR shall submit sufficient information as provided below to allow ENGINEER to determine that the item of material or equipment proposed is essentially equivalent to that named and an acceptable substitute therefor. Requests for review of proposed substitute items of material or equipment will not be accepted by ENGINEER from anyone other than CONTRACTOR.

c. The procedure for review by ENGINEER will be as set forth in paragraph 6.05.A.2.d, as supplemented in the General Requirements and as ENGINEER may decide is appropriate under the circumstances.

d. CONTRACTOR shall first make written application to ENGINEER for review of a proposed substitute item of material or equipment that CONTRACTOR seeks to furnish or use. The application shall certify

that the proposed substitute item will perform adequately the functions and achieve the results called for by the general design, be similar in substance to that specified, and be suited to the same use as that specified. The application will state the extent, if any, to which the use of the proposed substitute item will prejudice CONTRACTOR's achievement of Substantial Completion on time, whether or not use of the proposed substitute item in the Work will require a change in any of the Contract Documents (or in the provisions of any other direct contract with OWNER for work on the Project) to adapt the design to the proposed substitute item and whether or not incorporation or use of the proposed substitute item in connection with the Work is subject to payment of any license fee or royalty. All variations of the proposed substitute item from that specified will be identified in the application, and available engineering, sales, maintenance, repair, and replacement services will be indicated. The application will also contain an itemized estimate of all costs or credits that will result directly or indirectly from use of such substitute item, including costs of redesign and claims of other contractors affected by any resulting change, all of which will be considered by ENGINEER in evaluating the proposed substitute item. ENGINEER may require CONTRACTOR to furnish additional data about the proposed substitute item.

**B. Substitute Construction Methods or Procedures:** If a specific means, method, technique, sequence, or procedure of construction is shown or indicated in and expressly required by the Contract Documents, CONTRACTOR may furnish or utilize a substitute means, method, technique, sequence, or procedure of construction approved by ENGINEER. CONTRACTOR shall submit sufficient information to allow ENGINEER, in ENGINEER's sole discretion, to determine that the substitute proposed is equivalent to that expressly called for by the Contract Documents. The procedure for review by ENGINEER will be similar to that provided in subparagraph 6.05.A.2.

**C. Engineer's Evaluation:** ENGINEER will be allowed a reasonable time within which to evaluate each proposal or submittal made pursuant to paragraphs 6.05.A and 6.05.B. ENGINEER will be the sole judge of acceptability. No "or-equal" or substitute will be ordered, installed or utilized until ENGINEER's review is complete, which will be evidenced by either a Change Order for a

substitute or an approved Shop Drawing for an "or equal." ENGINEER will advise CONTRACTOR in writing of any negative determination.

**D. Special Guarantee:** OWNER may require CONTRACTOR to furnish at CONTRACTOR's expense a special performance guarantee or other surety with respect to any substitute.

**E. ENGINEER's Cost Reimbursement:** ENGINEER will record time required by ENGINEER and ENGINEER's Consultants in evaluating substitute proposed or submitted by CONTRACTOR pursuant to paragraphs 6.05.A.2 and 6.05.B and in making changes in the Contract Documents (or in the provisions of any other direct contract with OWNER for work on the Project) occasioned thereby. Whether or not ENGINEER approves a substitute item so proposed or submitted by CONTRACTOR, CONTRACTOR shall reimburse OWNER for the charges of ENGINEER and ENGINEER's Consultants for evaluating each such proposed substitute.

**F. CONTRACTOR's Expense:** CONTRACTOR shall provide all data in support of any proposed substitute or "or-equal" at CONTRACTOR's expense.

#### 6.06 Concerning Subcontractors, Suppliers, and Others

**A.** CONTRACTOR shall not employ any Subcontractor, Supplier, or other individual or entity (including those acceptable to OWNER as indicated in paragraph 6.06.B), whether initially or as a replacement, against whom OWNER may have reasonable objection. CONTRACTOR shall not be required to employ any Subcontractor, Supplier, or other individual or entity to furnish or perform any of the Work against whom CONTRACTOR has reasonable objection.

**B.** If the Supplementary Conditions require the identity of certain Subcontractors, Suppliers, or other individuals or entities to be submitted to OWNER in advance for acceptance by OWNER by a specified date prior to the Effective Date of the Agreement, and if CONTRACTOR has submitted a list thereof in accordance with the Supplementary Conditions, OWNER's acceptance (either in writing or by failing to make written objection thereto by the date indicated for acceptance or objection in the Bidding Documents or the Contract Documents) of any such Subcontractor, Supplier, or other individual or entity so identified may be revoked on the basis of reasonable objection after due investigation. CONTRACTOR shall submit an acceptable replacement

for the rejected Subcontractor, Supplier, or other individual or entity, and the Contract Price will be adjusted by the difference in the cost occasioned by such replacement, and an appropriate Change Order will be issued or Written Amendment signed. No acceptance by OWNER of any such Subcontractor, Supplier, or other individual or entity, whether initially or as a replacement, shall constitute a waiver of any right of OWNER or ENGINEER to reject defective Work.

C. CONTRACTOR shall be fully responsible to OWNER and ENGINEER for all acts and omissions of the Subcontractors, Suppliers, and other individuals or entities performing or furnishing any of the Work just as CONTRACTOR is responsible for CONTRACTOR's own acts and omissions. Nothing in the Contract Documents shall create for the benefit of any such Subcontractor, Supplier, or other individual or entity any contractual relationship between OWNER or ENGINEER and any such Subcontractor, Supplier or other individual or entity, nor shall it create any obligation on the part of OWNER or ENGINEER to pay or to see to the payment of any moneys due any such Subcontractor, Supplier, or other individual or entity except as may otherwise be required by Laws and Regulations.

D. CONTRACTOR shall be solely responsible for scheduling and coordinating the Work of Subcontractors, Suppliers, and other individuals or entities performing or furnishing any of the Work under a direct or indirect contract with CONTRACTOR.

E. CONTRACTOR shall require all Subcontractors, Suppliers, and such other individuals or entities performing or furnishing any of the Work to communicate with ENGINEER through CONTRACTOR.

F. The divisions and sections of the Specifications and the identifications of any Drawings shall not control CONTRACTOR in dividing the Work among Subcontractors or Suppliers or delineating the Work to be performed by any specific trade.

G. All Work performed for CONTRACTOR by a Subcontractor or Supplier will be pursuant to an appropriate agreement between CONTRACTOR and the Subcontractor or Supplier which specifically binds the Subcontractor or Supplier to the applicable terms and conditions of the Contract Documents for the benefit of OWNER and ENGINEER. Whenever any such agreement is with a Subcontractor or Supplier who is listed as an additional insured on the property insurance provided in paragraph 5.06, the agreement between the CONTRACTOR

and the Subcontractor or Supplier will contain provisions whereby the Subcontractor or Supplier waives all rights against OWNER, CONTRACTOR, ENGINEER, ENGINEER's Consultants, and all other individuals or entities identified in the Supplementary Conditions to be listed as insureds or additional insureds (and the officers, directors, partners, employees, agents, and other consultants and subcontractors of each and any of them) for all losses and damages caused by, arising out of, relating to, or resulting from any of the perils or causes of loss covered by such policies and any other property insurance applicable to the Work. If the insurers on any such policies require separate waiver forms to be signed by any Subcontractor or Supplier, CONTRACTOR will obtain the same.

#### 6.07 *Patent Fees and Royalties*

A. CONTRACTOR shall pay all license fees and royalties and assume all costs incident to the use in the performance of the Work or the incorporation in the Work of any invention, design, process, product, or device which is the subject of patent rights or copyrights held by others. If a particular invention, design, process, product, or device is specified in the Contract Documents for use in the performance of the Work and if to the actual knowledge of OWNER or ENGINEER its use is subject to patent rights or copyrights calling for the payment of any license fee or royalty to others, the existence of such rights shall be disclosed by OWNER in the Contract Documents. To the fullest extent permitted by Laws and Regulations, CONTRACTOR shall indemnify and hold harmless OWNER, ENGINEER, ENGINEER's Consultants, and the officers, directors, partners, employees or agents, and other consultants of each and any of them from and against all claims, costs, losses, and damages (including but not limited to all fees and charges of engineers, architects, attorneys, and other professionals and all court or arbitration or other dispute resolution costs) arising out of or relating to any infringement of patent rights or copyrights incident to the use in the performance of the Work or resulting from the incorporation in the Work of any invention, design, process, product, or device not specified in the Contract Documents.

#### 6.08 *Permits*

A. Unless otherwise provided in the Supplementary Conditions, CONTRACTOR shall obtain and pay for all construction permits and licenses. OWNER shall assist CONTRACTOR, when necessary, in obtaining such permits and licenses. CONTRACTOR shall pay all governmental charges and inspection fees necessary for

the prosecution of the Work which are applicable at the time of opening of Bids, or, if there are no Bids, on the Effective Date of the Agreement. CONTRACTOR shall pay all charges of utility owners for connections to the Work, and OWNER shall pay all charges of such utility owners for capital costs related thereto, such as plant investment fees.

#### 6.09 *Laws and Regulations*

A. CONTRACTOR shall give all notices and comply with all Laws and Regulations applicable to the performance of the Work. Except where otherwise expressly required by applicable Laws and Regulations, neither OWNER nor ENGINEER shall be responsible for monitoring CONTRACTOR's compliance with any Laws or Regulations.

B. If CONTRACTOR performs any Work knowing or having reason to know that it is contrary to Laws or Regulations, CONTRACTOR shall bear all claims, costs, losses, and damages (including but not limited to all fees and charges of engineers, architects, attorneys, and other professionals and all court or arbitration or other dispute resolution costs) arising out of or relating to such Work; however, it shall not be CONTRACTOR's primary responsibility to make certain that the Specifications and Drawings are in accordance with Laws and Regulations, but this shall not relieve CONTRACTOR of CONTRACTOR's obligations under paragraph 3.03.

C. Changes in Laws or Regulations not known at the time of opening of Bids (or, on the Effective Date of the Agreement if there were no Bids) having an effect on the cost or time of performance of the Work may be the subject of an adjustment in Contract Price or Contract Times. If OWNER and CONTRACTOR are unable to agree on entitlement to or on the amount or extent, if any, of any such adjustment, a Claim may be made therefor as provided in paragraph 10.05.

#### 6.10 *Taxes*

A. CONTRACTOR shall pay all sales, consumer, use, and other similar taxes required to be paid by CONTRACTOR in accordance with the Laws and Regulations of the place of the Project which are applicable during the performance of the Work.

#### 6.11 *Use of Site and Other Areas*

##### A. *Limitation on Use of Site and Other Areas*

1. CONTRACTOR shall confine construction equipment, the storage of materials and equipment, and the operations of workers to the Site and other areas permitted by Laws and Regulations,

and shall not unreasonably encumber the Site and other areas with construction equipment or other materials or equipment. CONTRACTOR shall assume full responsibility for any damage to any such land or area, or to the owner or occupant thereof, or of any adjacent land or areas resulting from the performance of the Work.

2. Should any claim be made by any such owner or occupant because of the performance of the Work, CONTRACTOR shall promptly settle with such other party by negotiation or otherwise resolve the claim by arbitration or other dispute resolution proceeding or at law.

3. To the fullest extent permitted by Laws and Regulations, CONTRACTOR shall indemnify and hold harmless OWNER, ENGINEER, ENGINEER's Consultant, and the officers, directors, partners, employees, agents, and other consultants of each and any of them from and against all claims, costs, losses, and damages (including but not limited to all fees and charges of engineers, architects, attorneys, and other professionals and all court or arbitration or other dispute resolution costs) arising out of or relating to any claim or action, legal or equitable, brought by any such owner or occupant against OWNER, ENGINEER, or any other party indemnified hereunder to the extent caused by or based upon CONTRACTOR's performance of the Work.

B. *Removal of Debris During Performance of the Work:* During the progress of the Work CONTRACTOR shall keep the Site and other areas free from accumulations of waste materials, rubbish, and other debris. Removal and disposal of such waste materials, rubbish, and other debris shall conform to applicable Laws and Regulations.

C. *Cleaning*: Prior to Substantial Completion of the Work CONTRACTOR shall clean the Site and make it ready for utilization by OWNER. At the completion of the Work CONTRACTOR shall remove from the Site all tools, appliances, construction equipment and machinery, and surplus materials and shall restore to original condition all property not designated for alteration by the Contract Documents.

D. *Loading Structures*: CONTRACTOR shall not load nor permit any part of any structure to be loaded in any manner that will endanger the structure, nor shall CONTRACTOR subject any part of the Work or adjacent property to stresses or pressures that will endanger it.

#### 6.12 *Record Documents*

A. CONTRACTOR shall maintain in a safe place at the Site one record copy of all Drawings, Specifications, Addenda, Written Amendments, Change Orders, Work Change Directives, Field Orders, and written interpretations and clarifications in good order and annotated to show changes made during construction. These record documents together with all approved Samples and a counterpart of all approved Shop Drawings will be available to ENGINEER for reference. Upon completion of the Work, these record documents, Samples, and Shop Drawings will be delivered to ENGINEER for OWNER.

#### 6.13 *Safety and Protection*

A. CONTRACTOR shall be solely responsible for initiating, maintaining and supervising all safety precautions and programs in connection with the Work. CONTRACTOR shall take all necessary precautions for the safety of, and shall provide the necessary protection to prevent damage, injury or loss to:

1. all persons on the Site or who may be affected by the Work;
2. all the Work and materials and equipment to be incorporated therein, whether in storage on or off the Site; and
3. other property at the Site or adjacent thereto, including trees, shrubs, lawns, walks, pavements, roadways, structures, utilities, and Underground Facilities not designated for removal, relocation, or replacement in the course of construction.

B. CONTRACTOR shall comply with all applicable Laws and Regulations relating to the safety of persons or property, or to the protection of persons or property from damage, injury, or loss; and shall erect and maintain all necessary safeguards for such safety and protection. CONTRACTOR shall notify owners of adjacent property and of Underground Facilities and other utility owners when prosecution of the Work may affect them, and shall cooperate with them in the protection, removal, relocation, and replacement of their property. All damage, injury, or loss to any property referred to in paragraph 6.13.A.2 or 6.13.A.3 caused, directly or indirectly, in whole or in part, by CONTRACTOR, any Subcontractor, Supplier, or any other individual or entity directly or indirectly employed by any of them to perform any of the Work, or anyone for whose acts any of them may be liable, shall be remedied by CONTRACTOR (except damage or loss attributable to the fault of Drawings or Specifications or to the acts or omissions of OWNER or ENGINEER or ENGINEER's Consultant, or anyone employed by any of them, or anyone for whose acts any of them may be liable, and not attributable, directly or indirectly, in whole or in part, to the fault or negligence of CONTRACTOR or any Subcontractor, Supplier, or other individual or entity directly or indirectly employed by any of them). CONTRACTOR's duties and responsibilities for safety and for protection of the Work shall continue until such time as all the Work is completed and ENGINEER has issued a notice to OWNER and CONTRACTOR in accordance with paragraph 14.07.B that the Work is acceptable (except as otherwise expressly provided in connection with Substantial Completion).

#### 6.14 *Safety Representative*

A. CONTRACTOR shall designate a qualified and experienced safety representative at the Site whose duties and responsibilities shall be the prevention of accidents and the maintaining and supervising of safety precautions and programs.

#### 6.15 *Hazard Communication Programs*

A. CONTRACTOR shall be responsible for coordinating any exchange of material safety data sheets or other hazard communication information required to be made available to or exchanged between or among employers at the Site in accordance with Laws or Regulations.

#### 6.16 *Emergencies*

A. In emergencies affecting the safety or protection of persons or the Work or property at the Site or adjacent thereto, CONTRACTOR is obligated to act to prevent threatened damage, injury, or loss. CONTRACTOR shall give ENGINEER prompt written notice if CONTRACTOR believes that any significant changes in the Work or variations from the Contract Documents have been caused thereby or are required as a result thereof. If ENGINEER determines that a change in the Contract Documents is required because of the action taken by CONTRACTOR in response to such an emergency, a Work Change Directive or Change Order will be issued.

#### 6.17 Shop Drawings and Samples

A. CONTRACTOR shall submit Shop Drawings to ENGINEER for review and approval in accordance with the acceptable schedule of Shop Drawings and Sample submittals. All submittals will be identified as ENGINEER may require and in the number of copies specified in the General Requirements. The data shown on the Shop Drawings will be complete with respect to quantities, dimensions, specified performance and design criteria, materials, and similar data to show ENGINEER the services, materials, and equipment CONTRACTOR proposes to provide and to enable ENGINEER to review the information for the limited purposes required by paragraph 6.17.E.

B. CONTRACTOR shall also submit six (6) Samples to ENGINEER for review and approval in accordance with the acceptable schedule of Shop Drawings and Sample submittals. Each Sample will be identified clearly as to material, Supplier, pertinent data such as catalog numbers, and the use for which intended and otherwise as ENGINEER may require to enable ENGINEER to review the submittal for the limited purposes required by paragraph 6.17.E. The numbers of each Sample to be submitted will be as specified in the Specifications.

C. Where a Shop Drawing or Sample is required by the Contract Documents or the schedule of Shop Drawings and Sample submittals acceptable to ENGINEER as required by paragraph 2.07, any related Work performed prior to ENGINEER's review and approval of the pertinent submittal will be at the sole expense and responsibility of CONTRACTOR.

#### D. Submittal Procedures

1. Before submitting each Shop Drawing or Sample, CONTRACTOR shall have determined and verified:

a. all field measurements, quantities, dimensions, specified performance criteria, installation requirements, materials, catalog numbers, and similar information with respect thereto;

b. all materials with respect to intended use, fabrication, shipping, handling, storage, assembly, and installation pertaining to the performance of the Work;

c. all information relative to means, methods, techniques, sequences, and procedures of construction and safety precautions and programs incident thereto; and

d. CONTRACTOR shall also have reviewed and coordinated each Shop Drawing or

Sample with other Shop Drawings and Samples and with the requirements of the Work and the Contract Documents.

2. Each submittal shall bear a stamp or specific written indication that CONTRACTOR has satisfied CONTRACTOR's obligations under the Contract Documents with respect to CONTRACTOR's review and approval of that submittal.

3. At the time of each submittal, CONTRACTOR shall give ENGINEER specific written notice of such variations, if any, that the Shop Drawing or Sample submitted may have from the requirements of the Contract Documents, such notice to be in a written communication separate from the submittal; and, in addition, shall cause a specific notation to be made on each Shop Drawing and Sample submitted to ENGINEER for review and approval of each such variation.

#### E. ENGINEER's Review

1. ENGINEER will timely review and approve Shop Drawings and Samples in accordance with the schedule of Shop Drawings and Sample submittals acceptable to ENGINEER. ENGINEER's review and approval will be only to determine if the items covered by the submittals

will, after installation or incorporation in the Work, conform to the information given in the Contract Documents and be compatible with the design concept of the completed Project as a functioning whole as indicated by the Contract Documents.

2. ENGINEER's review and approval will not extend to means, methods, techniques, sequences, or procedures of construction (except where a particular means, method, technique, sequence, or procedure of construction is specifically and expressly called for by the Contract Documents) or to safety precautions or programs incident thereto. The review and approval of a separate item as such will not indicate approval of the assembly in which the item functions.

3. ENGINEER's review and approval of Shop Drawings or Samples shall not relieve CONTRACTOR from responsibility for any variation from the requirements of the Contract Documents unless CONTRACTOR has in writing called ENGINEER's attention to each such variation at the time of each submittal as required by paragraph 6.17.D.3 and ENGINEER has given written approval of each such variation by specific written notation thereof incorporated in or accompanying the Shop Drawing or Sample approval; nor will any approval by ENGINEER relieve CONTRACTOR from responsibility for complying with the requirements of paragraph 6.17.D.1.

#### F. *Resubmittal Procedures*

1. CONTRACTOR shall make corrections required by ENGINEER and shall return the required number of corrected copies of Shop Drawings and submit as required new Samples for review and approval. CONTRACTOR shall direct specific attention in writing to revisions other than the corrections called for by ENGINEER on previous submittals.

#### 6.18 *Continuing the Work*

A. CONTRACTOR shall carry on the Work and adhere to the progress schedule during all disputes or disagreements with OWNER. No Work shall be delayed or postponed pending resolution of any disputes or disagreements, except as permitted by paragraph 15.04 or as OWNER and CONTRACTOR may otherwise agree in writing.

#### 6.19 *CONTRACTOR's General Warranty and Guarantee*

A. CONTRACTOR warrants and guarantees to OWNER, ENGINEER, and ENGINEER's Consultants that all Work will be in accordance with the Contract Documents and will not be defective. CONTRACTOR's warranty and guarantee hereunder excludes defects or damage caused by:

1. abuse, modification, or improper maintenance or operation by persons other than CONTRACTOR, Subcontractors, Suppliers, or any other individual or entity for whom CONTRACTOR is responsible; or

2. normal wear and tear under normal usage.

B. CONTRACTOR's obligation to perform and complete the Work in accordance with the Contract Documents shall be absolute. None of the following will constitute an acceptance of Work that is not in accordance with the Contract Documents or a release of CONTRACTOR's obligation to perform the Work in accordance with the Contract Documents:

1. observations by ENGINEER;

2. recommendation by ENGINEER or payment by OWNER of any progress or final payment;

3. the issuance of a certificate of Substantial Completion by ENGINEER or any payment related thereto by OWNER;

4. use or occupancy of the Work or any part thereof by OWNER;

5. any acceptance by OWNER or any failure to do so;

6. any review and approval of a Shop Drawing or Sample submittal or the issuance of a notice of acceptability by ENGINEER;

7. any inspection, test, or approval by others; or

8. any correction of defective Work by OWNER.

## 6.20 Indemnification

A. To the fullest extent permitted by Laws and Regulations, CONTRACTOR shall indemnify and hold harmless OWNER, ENGINEER, ENGINEER's Consultants, and the officers, directors, partners, employees, agents, and other consultants and subcontractors of each and any of them from and against all claims, costs, losses, and damages (including but not limited to all fees and charges of engineers, architects, attorneys, and other professionals and all court or arbitration or other dispute resolution costs) arising out of or relating to the performance of the Work, provided that any such claim, cost, loss, or damage:

1. is attributable to bodily injury, sickness, disease, or death, or to injury to or destruction of tangible property (other than the Work itself), including the loss of use resulting therefrom; and

2. is caused in whole or in part by any negligent act or omission of CONTRACTOR, any Subcontractor, any Supplier, or any individual or entity directly or indirectly employed by any of them to perform any of the Work or anyone for whose acts any of them may be liable, regardless of whether or not caused in part by any negligence or omission of an individual or entity indemnified hereunder or whether liability is imposed upon such indemnified party by Laws and Regulations regardless of the negligence of any such individual or entity.

B. In any and all claims against OWNER or ENGINEER or any of their respective consultants, agents, officers, directors, partners, or employees by any employee (or the survivor or personal representative of such employee) of CONTRACTOR, any Subcontractor, any Supplier, or any individual or entity directly or indirectly employed by any of them to perform any of the Work, or anyone for whose acts any of them may be liable, the indemnification obligation under paragraph 6.20.A shall not be limited in any way by any limitation on the amount or type of damages, compensation, or benefits payable by or for CONTRACTOR or any such Subcontractor, Supplier, or other individual or entity under workers' compensation acts, disability benefit acts, or other employee benefit acts.

C. The indemnification obligations of CONTRACTOR under paragraph 6.20.A shall not extend to the liability of ENGINEER and ENGINEER's Consultants or to the officers, directors, partners, employees, agents, and

other consultants and subcontractors of each and any of them arising out of:

1. the preparation or approval of, or the failure to prepare or approve, maps, Drawings, opinions, reports, surveys, Change Orders, designs, or Specifications; or

2. giving directions or instructions, or failing to give them, if that is the primary cause of the injury or damage.

## ARTICLE 7 - OTHER WORK

---

### 7.01 Related Work at Site

A. OWNER may perform other work related to the Project at the Site by OWNER's employees, or let other direct contracts therefor, or have other work performed by utility owners. If such other work is not noted in the Contract Documents, then:

1. written notice thereof will be given to CONTRACTOR prior to starting any such other work; and

2. if OWNER and CONTRACTOR are unable to agree on entitlement to or on the amount or extent, if any, of any adjustment in the Contract Price or Contract Times that should be allowed as a result of such other work, a Claim may be made therefor as provided in paragraph 10.05.

B. CONTRACTOR shall afford each other contractor who is a party to such a direct contract and each utility owner (and OWNER, if OWNER is performing the other work with OWNER's employees) proper and safe access to the Site and a reasonable opportunity for the introduction and storage of materials and equipment and the execution of such other work and shall properly coordinate the Work with theirs. Unless otherwise provided in the Contract Documents, CONTRACTOR shall do all cutting, fitting, and patching of the Work that may be required to properly connect or otherwise make its several parts come together and properly integrate with such other work. CONTRACTOR shall not endanger any work of others by cutting, excavating, or otherwise altering their work and will only cut or alter their work with the written consent of ENGINEER and the others whose work will be affected. The duties and responsibilities of CONTRACTOR under this paragraph are for the benefit of

such utility owners and other contractors to the extent that there are comparable provisions for the benefit of CONTRACTOR in said direct contracts between OWNER and such utility owners and other contractors.

C. If the proper execution or results of any part of CONTRACTOR's Work depends upon work performed by others under this Article 7, CONTRACTOR shall inspect such other work and promptly report to ENGINEER in writing any delays, defects, or deficiencies in such other work that render it unavailable or unsuitable for the proper execution and results of CONTRACTOR's Work. CONTRACTOR's failure to so report will constitute an acceptance of such other work as fit and proper for integration with CONTRACTOR's Work except for latent defects and deficiencies in such other work.

#### 7.02 *Coordination*

A. If OWNER intends to contract with others for the performance of other work on the Project at the Site, the following will be set forth in Supplementary Conditions:

1. the individual or entity who will have authority and responsibility for coordination of the activities among the various contractors will be identified;
2. the specific matters to be covered by such authority and responsibility will be itemized; and
3. the extent of such authority and responsibilities will be provided.

B. Unless otherwise provided in the Supplementary Conditions, OWNER shall have sole authority and responsibility for such coordination.

### ARTICLE 8 - OWNER'S RESPONSIBILITIES

---

#### 8.01 *Communications to Contractor*

A. Except as otherwise provided in these General Conditions, OWNER shall issue all communications to CONTRACTOR through ENGINEER.

#### 8.02 *Replacement of ENGINEER*

A. In case of termination of the employment of ENGINEER, OWNER shall appoint an engineer to whom CONTRACTOR makes no reasonable objection, whose status under the Contract Documents shall be that of the former ENGINEER.

#### 8.03 *Furnish Data*

A. OWNER shall promptly furnish the data required of OWNER under the Contract Documents.

#### 8.04 *Pay Promptly When Due*

A. OWNER shall make payments to CONTRACTOR promptly when they are due as provided in paragraphs 14.02.C and 14.07.C.

#### 8.05 *Lands and Easements; Reports and Tests*

A. OWNER's duties in respect of providing lands and easements and providing engineering surveys to establish reference points are set forth in paragraphs 4.01 and 4.05. Paragraph 4.02 refers to OWNER's identifying and making available to CONTRACTOR copies of reports and drawings of physical conditions and tests of subsurface conditions and drawings of physical conditions in or relating to existing surface or subsurface structures at or contiguous to the Site that have been utilized by ENGINEER in preparing the Contract Documents.

#### 8.06 *Insurance*

A. OWNER's responsibilities, if any, in respect to purchasing and maintaining liability and property insurance are set forth in Article 5.

#### 8.07 *Change Orders*

A. OWNER is obligated to execute Change Orders as indicated in paragraph 10.03.

#### 8.08 *Inspections, Tests, and Approvals*

A. OWNER's responsibility in respect to certain inspections, tests, and approvals is set forth in paragraph 13.03.B.

8.09 *Limitations on OWNER's Responsibilities*

A. The OWNER shall not supervise, direct, or have control or authority over, nor be responsible for, CONTRACTOR's means, methods, techniques, sequences, or procedures of construction, or the safety precautions and programs incident thereto, or for any failure of CONTRACTOR to comply with Laws and Regulations applicable to the performance of the Work. OWNER will not be responsible for CONTRACTOR's failure to perform the Work in accordance with the Contract Documents.

8.10 *Undisclosed Hazardous Environmental Condition*

A. OWNER's responsibility in respect to an undisclosed Hazardous Environmental Condition is set forth in paragraph 4.06.

8.11 *Evidence of Financial Arrangements*

A. If and to the extent OWNER has agreed to furnish CONTRACTOR reasonable evidence that financial arrangements have been made to satisfy OWNER's obligations under the Contract Documents, OWNER's responsibility in respect thereof will be as set forth in the Supplementary Conditions.

ARTICLE 9 - ENGINEER'S STATUS DURING CONSTRUCTION

---

9.01 *OWNER'S Representative*

A. ENGINEER will be OWNER's representative during the construction period. The duties and responsibilities and the limitations of authority of ENGINEER as OWNER's representative during construction are set forth in the Contract Documents and will not be changed without written consent of OWNER and ENGINEER.

9.02 *Visits to Site*

A. ENGINEER will make visits to the Site at intervals appropriate to the various stages of construction as ENGINEER deems necessary in order to observe as an experienced and qualified design professional the progress that has been made and the quality of the various aspects of CONTRACTOR's executed Work. Based on information obtained during such visits and

observations, ENGINEER, for the benefit of OWNER, will determine, in general, if the Work is proceeding in accordance with the Contract Documents. ENGINEER will not be required to make exhaustive or continuous inspections on the Site to check the quality or quantity of the Work. ENGINEER's efforts will be directed toward providing for OWNER a greater degree of confidence that the completed Work will conform generally to the Contract Documents. On the basis of such visits and observations, ENGINEER will keep OWNER informed of the progress of the Work and will endeavor to guard OWNER against defective Work.

B. ENGINEER's visits and observations are subject to all the limitations on ENGINEER's authority and responsibility set forth in paragraph 9.10, and particularly, but without limitation, during or as a result of ENGINEER's visits or observations of CONTRACTOR's Work ENGINEER will not supervise, direct, control, or have authority over or be responsible for CONTRACTOR's means, methods, techniques, sequences, or procedures of construction, or the safety precautions and programs incident thereto, or for any failure of CONTRACTOR to comply with Laws and Regulations applicable to the performance of the Work.

9.03 *Project Representative*

A. If OWNER and ENGINEER agree, ENGINEER will furnish a Resident Project Representative to assist ENGINEER in providing more extensive observation of the Work. The responsibilities and authority and limitations thereon of any such Resident Project Representative and assistants will be as provided in paragraph 9.10 and in the Supplementary Conditions. If OWNER designates another representative or agent to represent OWNER at the Site who is not ENGINEER's Consultant, agent or employee,

the responsibilities and authority and limitations thereon of such other individual or entity will be as provided in the Supplementary Conditions.

9.04 *Clarifications and Interpretations*

A. ENGINEER will issue with reasonable promptness such written clarifications or interpretations of the requirements of the Contract Documents as ENGINEER may determine necessary, which shall be consistent with the intent of and reasonably inferable from the Contract Docu-

ments. Such written clarifications and interpretations will be binding on OWNER and CONTRACTOR. If OWNER and CONTRACTOR are unable to agree on entitlement to or on the amount or extent, if any, of any adjustment in the Contract Price or Contract Times, or both, that should be allowed as a result of a written clarification or interpretation, a Claim may be made therefor as provided in paragraph 10.05.

#### 9.05 *Authorized Variations in Work*

A. ENGINEER may authorize minor variations in the Work from the requirements of the Contract Documents which do not involve an adjustment in the Contract Price or the Contract Times and are compatible with the design concept of the completed Project as a functioning whole as indicated by the Contract Documents. These may be accomplished by a Field Order and will be binding on OWNER and also on CONTRACTOR, who shall perform the Work involved promptly. If OWNER and CONTRACTOR are unable to agree on entitlement to or on the amount or extent, if any, of any adjustment in the Contract Price or Contract Times, or both, as a result of a Field Order, a Claim may be made therefor as provided in paragraph 10.05.

#### 9.06 *Rejecting Defective Work*

A. ENGINEER will have authority to disapprove or reject Work which ENGINEER believes to be defective, or that ENGINEER believes will not produce a completed Project that conforms to the Contract Documents or that will prejudice the integrity of the design concept of the completed Project as a functioning whole as indicated by the Contract Documents. ENGINEER will also have authority to require special inspection or testing of the Work as provided in paragraph 13.04, whether or not the Work is fabricated, installed, or completed.

#### 9.07 *Shop Drawings, Change Orders and Payments*

A. In connection with ENGINEER's authority as to Shop Drawings and Samples, see paragraph 6.17.

B. In connection with ENGINEER's authority as to Change Orders, see Articles 10, 11, and 12.

C. In connection with ENGINEER's authority as to Applications for Payment, see Article 14.

#### 9.08 *Determinations for Unit Price Work*

A. ENGINEER will determine the actual quantities and classifications of Unit Price Work performed by CONTRACTOR. ENGINEER will review with CONTRACTOR the ENGINEER's preliminary determinations on such matters before rendering a written decision thereon (by recommendation of an Application for Payment or otherwise). ENGINEER's written decision thereon will be final and binding (except as modified by ENGINEER to reflect changed factual conditions or more accurate data) upon OWNER and CONTRACTOR, subject to the provisions of paragraph 10.05.

#### 9.09 *Decisions on Requirements of Contract Documents and Acceptability of Work*

A. ENGINEER will be the initial interpreter of the requirements of the Contract Documents and judge of the acceptability of the Work thereunder. Claims, disputes and other matters relating to the acceptability of the Work, the quantities and classifications of Unit Price Work, the interpretation of the requirements of the Contract Documents pertaining to the performance of the Work, and Claims seeking changes in the Contract Price or Contract Times will be referred initially to ENGINEER in writing, in accordance with the provisions of paragraph 10.05, with a request for a formal decision.

B. When functioning as interpreter and judge under this paragraph 9.09, ENGINEER will not show partiality to OWNER or CONTRACTOR and will not be liable in connection with any interpretation or decision rendered in good faith in such capacity. The rendering of a decision by ENGINEER pursuant to this paragraph 9.09 with respect to any such Claim, dispute, or other matter (except any which have been waived by the making or acceptance of final payment as provided in paragraph 14.07) will be a condition precedent to any exercise by OWNER or CONTRACTOR of such rights or remedies as either may otherwise have under the Contract Documents or by Laws or Regulations in respect of any such Claim, dispute, or other matter.

#### 9.10 *Limitations on ENGINEER's Authority and Responsibilities*

A. Neither ENGINEER's authority or responsibility under this Article 9 or under any other provision of the Contract Documents nor any decision made by ENGINEER in good faith either to exercise or not exercise such

authority or responsibility or the undertaking, exercise, or performance of any authority or responsibility by ENGINEER shall create, impose, or give rise to any duty in contract, tort, or otherwise owed by ENGINEER to CONTRACTOR, any Subcontractor, any Supplier, any other individual or entity, or to any surety for or employee or agent of any of them.

B. ENGINEER will not supervise, direct, control, or have authority over or be responsible for CONTRACTOR's means, methods, techniques, sequences, or procedures of construction, or the safety precautions and programs incident thereto, or for any failure of CONTRACTOR to comply with Laws and Regulations applicable to the performance of the Work. ENGINEER will not be responsible for CONTRACTOR's failure to perform the Work in accordance with the Contract Documents.

C. ENGINEER will not be responsible for the acts or omissions of CONTRACTOR or of any Subcontractor, any Supplier, or of any other individual or entity performing any of the Work.

D. ENGINEER's review of the final Application for Payment and accompanying documentation and all maintenance and operating instructions, schedules, guarantees, Bonds, certificates of inspection, tests and approvals, and other documentation required to be delivered by paragraph 14.07.A will only be to determine generally that their content complies with the requirements of, and in the case of certificates of inspections, tests, and approvals that the results certified indicate compliance with, the Contract Documents.

E. The limitations upon authority and responsibility set forth in this paragraph 9.10 shall also apply to ENGINEER's Consultants, Resident Project Representative, and assistants. See Article 18.

## ARTICLE 10 - CHANGES IN THE WORK; CLAIMS

---

### 10.01 *Authorized Changes in the Work*

A. Without invalidating the Agreement and without notice to any surety, OWNER may, at any time or from time to time, order additions, deletions, or revisions in the Work by a Written Amendment, a Change Order, or a Work Change Directive. Upon receipt of any such document, CONTRACTOR shall promptly proceed with the Work involved which will be performed under the

applicable conditions of the Contract Documents (except as otherwise specifically provided).

B. If OWNER and CONTRACTOR are unable to agree on entitlement to, or on the amount or extent, if any, of an adjustment in the Contract Price or Contract Times, or both, that should be allowed as a result of a Work Change Directive, a Claim may be made therefor as provided in paragraph 10.05.

### 10.02 *Unauthorized Changes in the Work*

A. CONTRACTOR shall not be entitled to an increase in the Contract Price or an extension of the Contract Times with respect to any work performed that is not required by the Contract Documents as amended, modified, or supplemented as provided in paragraph 3.04, except in the case of an emergency as provided in paragraph 6.16 or in the case of uncovering Work as provided in paragraph 13.04.B.

### 10.03 *Execution of Change Orders*

A. OWNER and CONTRACTOR shall execute appropriate Change Orders recommended by ENGINEER (or Written Amendments) covering:

1. changes in the Work which are: (i) ordered by OWNER pursuant to paragraph 10.01.A, (ii) required because of acceptance of defective Work under paragraph 13.08.A or OWNER's correction of defective Work under paragraph 13.09, or (iii) agreed to by the parties;

2. changes in the Contract Price or Contract Times which are agreed to by the parties, including any undisputed sum or amount of time for Work actually performed in accordance with a Work Change Directive; and

3. changes in the Contract Price or Contract Times which embody the substance of any written decision rendered by ENGINEER pursuant to paragraph 10.05; provided that, in lieu of executing any such Change Order, an appeal may be taken from any such decision in accordance with the provisions of the Contract Documents and applicable Laws and Regulations, but during any such appeal, CONTRACTOR shall carry on the Work and adhere to the progress schedule as provided in paragraph 6.18.A.

#### 10.04 *Notification to Surety*

A. If notice of any change affecting the general scope of the Work or the provisions of the Contract Documents (including, but not limited to, Contract Price or Contract Times) is required by the provisions of any Bond to be given to a surety, the giving of any such notice will be CONTRACTOR's responsibility. The amount of each applicable Bond will be adjusted to reflect the effect of any such change.

#### 10.05 *Claims and Disputes*

A. *Notice:* Written notice stating the general nature of each Claim, dispute, or other matter shall be delivered by the claimant to ENGINEER and the other party to the Contract promptly (but in no event later than 30 days) after the start of the event giving rise thereto. Notice of the amount or extent of the Claim, dispute, or other matter with supporting data shall be delivered to the ENGINEER and the other party to the Contract within 60 days after the start of such event (unless ENGINEER allows additional time for claimant to submit additional or more accurate data in support of such Claim, dispute, or other matter). A Claim for an adjustment in Contract Price shall be prepared in accordance with the provisions of paragraph 12.01.B. A Claim for an adjustment in Contract Time shall be prepared in accordance with the provisions of paragraph 12.02.B. Each Claim shall be accompanied by claimant's written statement that the adjustment claimed is the entire adjustment to which the claimant believes it is entitled as a result of said event. The opposing party shall submit any response to ENGINEER and the claimant within 30 days after receipt of the claimant's last submittal (unless ENGINEER allows additional time).

B. *ENGINEER's Decision:* ENGINEER will render a formal decision in writing within 30 days after receipt of the last submittal of the claimant or the last submittal of the opposing party, if any. ENGINEER's written decision on such Claim, dispute, or other matter will be final and binding upon OWNER and CONTRACTOR unless:

1. an appeal from ENGINEER's decision is taken within the time limits and in accordance with the dispute resolution procedures set forth in Article 16; or

2. if no such dispute resolution procedures have been set forth in Article 16, a written notice of intention to appeal from ENGINEER's written decision is delivered by OWNER or CONTRACTOR to the other and to ENGINEER within 30 days

after the date of such decision, and a formal proceeding is instituted by the appealing party in a forum of competent jurisdiction within 60 days after the date of such decision or within 60 days after Substantial Completion, whichever is later (unless otherwise agreed in writing by OWNER and CONTRACTOR), to exercise such rights or remedies as the appealing party may have with respect to such Claim, dispute, or other matter in accordance with applicable Laws and Regulations.

C. If ENGINEER does not render a formal decision in writing within the time stated in paragraph 10.05.B, a decision denying the Claim in its entirety shall be deemed to have been issued 31 days after receipt of the last submittal of the claimant or the last submittal of the opposing party, if any.

D. No Claim for an adjustment in Contract Price or Contract Times (or Milestones) will be valid if not submitted in accordance with this paragraph 10.05.

#### ARTICLE 11 - COST OF THE WORK; CASH ALLOWANCES; UNIT PRICE WORK

---

##### 11.01 *Cost of the Work*

A. *Costs Included:* The term Cost of the Work means the sum of all costs necessarily incurred and paid by CONTRACTOR in the proper performance of the Work. When the value of any Work covered by a Change Order or when a Claim for an adjustment in Contract Price is determined on the basis of Cost of the Work, the costs to be reimbursed to CONTRACTOR will be only those additional or incremental costs required because of the change in the Work or because of the event giving rise to the Claim. Except as otherwise may be agreed to in writing by OWNER, such costs shall be in amounts no higher than those prevailing in the locality of the Project, shall include only the following items, and shall not include any of the costs itemized in paragraph 11.01.B.

1. Payroll costs for employees in the direct employ of CONTRACTOR in the performance of the Work under schedules of job classifications agreed upon by OWNER and CONTRACTOR. Such employees shall include without limitation superintendents, foremen, and other personnel employed full time at the Site. Payroll costs for employees not employed full time on the Work

shall be apportioned on the basis of their time spent on the Work. Payroll costs shall include, but not be limited to, salaries and wages plus the cost of fringe benefits, which shall include social security contributions, unemployment, excise, and payroll taxes, workers' compensation, health and retirement benefits, bonuses, sick leave, vacation and holiday pay applicable thereto. The expenses of performing Work outside of regular working hours, on Saturday, Sunday, or legal holidays, shall be included in the above to the extent authorized by OWNER.

2. Cost of all materials and equipment furnished and incorporated in the Work, including costs of transportation and storage thereof, and Suppliers' field services required in connection therewith. All cash discounts shall accrue to CONTRACTOR unless OWNER deposits funds with CONTRACTOR with which to make payments, in which case the cash discounts shall accrue to OWNER. All trade discounts, rebates and refunds and returns from sale of surplus materials and equipment shall accrue to OWNER, and CONTRACTOR shall make provisions so that they may be obtained.

3. Payments made by CONTRACTOR to Subcontractors for Work performed by Subcontractors. If required by OWNER, CONTRACTOR shall obtain competitive bids from subcontractors acceptable to OWNER and CONTRACTOR and shall deliver such bids to OWNER, who will then determine, with the advice of ENGINEER, which bids, if any, will be acceptable. If any subcontract provides that the Subcontractor is to be paid on the basis of Cost of the Work plus a fee, the Subcontractor's Cost of the Work and fee shall be determined in the same manner as CONTRACTOR's Cost of the Work and fee as provided in this paragraph 11.01.

4. Costs of special consultants (including but not limited to engineers, architects, testing laboratories, surveyors, attorneys, and accountants) employed for services specifically related to the Work.

5. Supplemental costs including the following:

a. The proportion of necessary transportation, travel, and subsistence expenses of

CONTRACTOR's employees incurred in discharge of duties connected with the Work.

b. Cost, including transportation and maintenance, of all materials, supplies, equipment, machinery, appliances, office, and temporary facilities at the Site, and hand tools not owned by the workers, which are consumed in the performance of the Work, and cost, less market value, of such items used but not consumed which remain the property of CONTRACTOR.

c. Rentals of all construction equipment and machinery, and the parts thereof whether rented from CONTRACTOR or others in accordance with rental agreements approved by OWNER with the advice of ENGINEER, and the costs of transportation, loading, unloading, assembly, dismantling, and removal thereof. All such costs shall be in accordance with the terms of said rental agreements. The rental of any such equipment, machinery, or parts shall cease when the use thereof is no longer necessary for the Work.

d. Sales, consumer, use, and other similar taxes related to the Work, and for which CONTRACTOR is liable, imposed by Laws and Regulations.

e. Deposits lost for causes other than negligence of CONTRACTOR, any Subcontractor, or anyone directly or indirectly employed by any of them or for whose acts any of them may be liable, and royalty payments and fees for permits and licenses.

f. Losses and damages (and related expenses) caused by damage to the Work, not compensated by insurance or otherwise, sustained by CONTRACTOR in connection with the performance of the Work (except losses and damages within the deductible amounts of property insurance established in accordance with paragraph 5.06.D), provided such losses and damages have resulted from causes other than the negligence of CONTRACTOR, any Subcontractor, or anyone directly or indirectly employed by any of them or for whose acts any of them may be liable. Such losses shall include settlements made with the written consent and approval of OWNER. No such losses, damages, and expenses shall be included in the Cost of the Work for the purpose of determining CONTRACTOR's fee.

g. The cost of utilities, fuel, and sanitary facilities at the Site.

h. Minor expenses such as telegrams, long distance telephone calls, telephone service at the Site, expressage, and similar petty cash items in connection with the Work.

i. When the Cost of the Work is used to determine the value of a Change Order or of a Claim, the cost of premiums for additional Bonds and insurance required because of the changes in the Work or caused by the event giving rise to the Claim.

j. When all the Work is performed on the basis of cost-plus, the costs of premiums for all Bonds and insurance CONTRACTOR is required by the Contract Documents to purchase and maintain.

B. *Costs Excluded:* The term Cost of the Work shall not include any of the following items:

1. Payroll costs and other compensation of CONTRACTOR's officers, executives, principals (of partnerships and sole proprietorships), general managers, engineers, architects, estimators, attorneys, auditors, accountants, purchasing and contracting agents, expeditors, timekeepers, clerks, and other personnel employed by CONTRACTOR, whether at the Site or in CONTRACTOR's principal or branch office for general administration of the Work and not specifically included in the agreed upon schedule of job classifications referred to in paragraph 11.01.A.1 or specifically covered by paragraph 11.01.A.4, all of which are to be considered administrative costs covered by the CONTRACTOR's fee.

2. Expenses of CONTRACTOR's principal and branch offices other than CONTRACTOR's office at the Site.

3. Any part of CONTRACTOR's capital expenses, including interest on CONTRACTOR's capital employed for the Work and charges against CONTRACTOR for delinquent payments.

4. Costs due to the negligence of CONTRACTOR, any Subcontractor, or anyone directly or indirectly employed by any of them or for whose acts any of them may be liable, including but not

limited to, the correction of defective Work, disposal of materials or equipment wrongly supplied, and making good any damage to property.

5. Other overhead or general expense costs of any kind and the costs of any item not specifically and expressly included in paragraphs 11.01.A and 11.01.B.

C. *CONTRACTOR's Fee:* When all the Work is performed on the basis of cost-plus, CONTRACTOR's fee shall be determined as set forth in the Agreement. When the value of any Work covered by a Change Order or when a Claim for an adjustment in Contract Price is determined on the basis of Cost of the Work, CONTRACTOR's fee shall be determined as set forth in paragraph 12.01.C.

D. *Documentation:* Whenever the Cost of the Work for any purpose is to be determined pursuant to paragraphs 11.01.A and 11.01.B, CONTRACTOR will establish and maintain records thereof in accordance with generally accepted accounting practices and submit in a form acceptable to ENGINEER an itemized cost breakdown together with supporting data.

#### 11.02 *Cash Allowances*

A. It is understood that CONTRACTOR has included in the Contract Price all allowances so named in the Contract Documents and shall cause the Work so covered to be performed for such sums as may be acceptable to OWNER and ENGINEER. CONTRACTOR agrees that:

1. the allowances include the cost to CONTRACTOR (less any applicable trade discounts) of materials and equipment required by the allowances to be delivered at the Site, and all applicable taxes; and

2. CONTRACTOR's costs for unloading and handling on the Site, labor, installation costs, overhead, profit, and other expenses contemplated for the allowances have been included in the Contract Price and not in the allowances, and no demand for additional payment on account of any of the foregoing will be valid.

B. Prior to final payment, an appropriate Change Order will be issued as recommended by ENGINEER to reflect actual amounts due CONTRACTOR on account of

Work covered by allowances, and the Contract Price shall be correspondingly adjusted.

#### 11.03 *Unit Price Work*

A. Where the Contract Documents provide that all or part of the Work is to be Unit Price Work, initially the Contract Price will be deemed to include for all Unit Price Work an amount equal to the sum of the unit price for each separately identified item of Unit Price Work times the estimated quantity of each item as indicated in the Agreement. The estimated quantities of items of Unit Price Work are not guaranteed and are solely for the purpose of comparison of Bids and determining an initial Contract Price. Determinations of the actual quantities and classifications of Unit Price Work performed by CONTRACTOR will be made by ENGINEER subject to the provisions of paragraph 9.08.

B. Each unit price will be deemed to include an amount considered by CONTRACTOR to be adequate to cover CONTRACTOR's overhead and profit for each separately identified item.

C. OWNER or CONTRACTOR may make a Claim for an adjustment in the Contract Price in accordance with paragraph 10.05 if:

1. the quantity of any item of Unit Price Work performed by CONTRACTOR differs materially and significantly from the estimated quantity of such item indicated in the Agreement; and
2. there is no corresponding adjustment with respect any other item of Work; and
3. if CONTRACTOR believes that CONTRACTOR is entitled to an increase in Contract Price as a result of having incurred additional expense or OWNER believes that OWNER is entitled to a decrease in Contract Price and the parties are unable to agree as to the amount of any such increase or decrease.

## ARTICLE 12 - CHANGE OF CONTRACT PRICE; CHANGE OF CONTRACT TIMES

---

#### 12.01 *Change of Contract Price*

A. The Contract Price may only be changed by a Change Order or by a Written Amendment. Any Claim for an adjustment in the Contract Price shall be based on written notice submitted by the party making the Claim to the ENGINEER and the other party to the Contract in accordance with the provisions of paragraph 10.05.

B. The value of any Work covered by a Change Order or of any Claim for an adjustment in the Contract Price will be determined as follows:

1. where the Work involved is covered by unit prices contained in the Contract Documents, by application of such unit prices to the quantities of the items involved (subject to the provisions of paragraph 11.03 ); or
2. where the Work involved is not covered by unit prices contained in the Contract Documents, by a mutually agreed lump sum (which may include an allowance for overhead and profit not necessarily in accordance with paragraph 12.01.C.2); or
3. where the Work involved is not covered by unit prices contained in the Contract Documents and agreement to a lump sum is not reached under paragraph 12.01.B.2, on the basis of the Cost of the Work (determined as provided in paragraph 11.01) plus a CONTRACTOR's fee for overhead and profit (determined as provided in paragraph 12.01.C).

C. *CONTRACTOR's Fee:* The CONTRACTOR's fee for overhead and profit shall be determined as follows:

1. a mutually acceptable fixed fee; or
2. if a fixed fee is not agreed upon, then a fee based on the following percentages of the various portions of the Cost of the Work:
  - a. for costs incurred under paragraphs 11.01.A.1 and 11.01.A.2, the CONTRACTOR's fee shall be 15 percent;

b. for costs incurred under paragraph 11.01.A.3, the CONTRACTOR's fee shall be five percent;

c. where one or more tiers of subcontracts are on the basis of Cost of the Work plus a fee and no fixed fee is agreed upon, the intent of paragraph 12.01.C.2.a is that the Subcontractor who actually performs the Work, at whatever tier, will be paid a fee of 15 percent of the costs incurred by such Subcontractor under paragraphs 11.01.A.1 and 11.01.A.2 and that any higher tier Subcontractor and CONTRACTOR will each be paid a fee of five percent of the amount paid to the next lower tier Subcontractor;

d. no fee shall be payable on the basis of costs itemized under paragraphs 11.01.A.4, 11.01.A.5, and 11.01.B;

e. the amount of credit to be allowed by CONTRACTOR to OWNER for any change which results in a net decrease in cost will be the amount of the actual net decrease in cost plus a deduction in CONTRACTOR's fee by an amount equal to five percent of such net decrease; and

f. when both additions and credits are involved in any one change, the adjustment in CONTRACTOR's fee shall be computed on the basis of the net change in accordance with paragraphs 12.01.C.2.a through 12.01.C.2.e, inclusive.

## 12.02 *Change of Contract Times*

A. The Contract Times (or Milestones) may only be changed by a Change Order or by a Written Amendment. Any Claim for an adjustment in the Contract Times (or Milestones) shall be based on written notice submitted by the party making the claim to the ENGINEER and the other party to the Contract in accordance with the provisions of paragraph 10.05.

B. Any adjustment of the Contract Times (or Milestones) covered by a Change Order or of any Claim for an adjustment in the Contract Times (or Milestones)

will be determined in accordance with the provisions of this Article 12.

## 12.03 *Delays Beyond CONTRACTOR's Control*

A. Where CONTRACTOR is prevented from completing any part of the Work within the Contract Times (or Milestones) due to delay beyond the control of CONTRACTOR, the Contract Times (or Milestones) will be extended in an amount equal to the time lost due to such delay if a Claim is made therefor as provided in paragraph 12.02.A. Delays beyond the control of CONTRACTOR shall include, but not be limited to, acts or neglect by OWNER, acts or neglect of utility owners or other contractors performing other work as contemplated by Article 7, fires, floods, epidemics, abnormal weather conditions, or acts of God.

## 12.04 *Delays Within CONTRACTOR's Control*

A. The Contract Times (or Milestones) will not be extended due to delays within the control of CONTRACTOR. Delays attributable to and within the control of a Subcontractor or Supplier shall be deemed to be delays within the control of CONTRACTOR.

## 12.05 *Delays Beyond OWNER's and CONTRACTOR's Control*

A. Where CONTRACTOR is prevented from completing any part of the Work within the Contract Times (or Milestones) due to delay beyond the control of both OWNER and CONTRACTOR, an extension of the Contract Times (or Milestones) in an amount equal to the time lost due to such delay shall be CONTRACTOR's sole and exclusive remedy for such delay.

## 12.06 *Delay Damages*

A. In no event shall OWNER or ENGINEER be liable to CONTRACTOR, any Subcontractor, any Supplier, or any other person or organization, or to any surety for or employee or agent of any of them, for damages arising out of or resulting from:

1. delays caused by or within the control of CONTRACTOR; or

2. delays beyond the control of both OWNER and CONTRACTOR including but not limited to fires, floods, epidemics, abnormal weather conditions, acts of God, or acts or neglect by utility

owners or other contractors performing other work as contemplated by Article 7.

B. Nothing in this paragraph 12.06 bars a change in Contract Price pursuant to this Article 12 to compensate CONTRACTOR due to delay, interference, or disruption directly attributable to actions or inactions of OWNER or anyone for whom OWNER is responsible.

ARTICLE 13 - TESTS AND INSPECTIONS;  
CORRECTION, REMOVAL OR ACCEPTANCE OF  
DEFECTIVE WORK

---

13.01 *Notice of Defects*

A. Prompt notice of all defective Work of which OWNER or ENGINEER has actual knowledge will be given to CONTRACTOR. All defective Work may be rejected, corrected, or accepted as provided in this Article 13.

13.02 *Access to Work*

A. OWNER, ENGINEER, ENGINEER's Consultants, other representatives and personnel of OWNER, independent testing laboratories, and governmental agencies with jurisdictional interests will have access to the Site and the Work at reasonable times for their observation, inspecting, and testing. CONTRACTOR shall provide them proper and safe conditions for such access and advise them of CONTRACTOR's Site safety procedures and programs so that they may comply therewith as applicable.

13.03 *Tests and Inspections*

A. CONTRACTOR shall give ENGINEER timely notice of readiness of the Work for all required inspections, tests, or approvals and shall cooperate with inspection and testing personnel to facilitate required inspections or tests.

B. OWNER shall employ and pay for the services of an independent testing laboratory to perform all inspections, tests, or approvals required by the Contract Documents except:

1. for inspections, tests, or approvals covered by paragraphs 13.03.C and 13.03.D below;

2. that costs incurred in connection with tests or inspections conducted pursuant to paragraph 13.04.B shall be paid as provided in said paragraph 13.04.B; and

3. as otherwise specifically provided in the Contract Documents.

C. If Laws or Regulations of any public body having jurisdiction require any Work (or part thereof) specifically to be inspected, tested, or approved by an employee or other representative of such public body, CONTRACTOR shall assume full responsibility for arranging and obtaining such inspections, tests, or approvals, pay all costs in connection therewith, and furnish ENGINEER the required certificates of inspection or approval.

D. CONTRACTOR shall be responsible for arranging and obtaining and shall pay all costs in connection with any inspections, tests, or approvals required for OWNER's and ENGINEER's acceptance of materials or equipment to be incorporated in the Work; or acceptance of materials, mix designs, or equipment submitted for approval prior to CONTRACTOR's purchase thereof for incorporation in the Work. Such inspections, tests, or approvals shall be performed by organizations acceptable to OWNER and ENGINEER.

E. If any Work (or the work of others) that is to be inspected, tested, or approved is covered by CONTRACTOR without written concurrence of ENGINEER, it must, if requested by ENGINEER, be uncovered for observation.

F. Uncovering Work as provided in paragraph 13.03.E shall be at CONTRACTOR's expense unless CONTRACTOR has given ENGINEER timely notice of CONTRACTOR's intention to cover the same and ENGINEER has not acted with reasonable promptness in response to such notice.

13.04 *Uncovering Work*

A. If any Work is covered contrary to the written request of ENGINEER, it must, if requested by ENGINEER, be uncovered for ENGINEER's observation and replaced at CONTRACTOR's expense.

B. If ENGINEER considers it necessary or advisable that covered Work be observed by ENGINEER or inspected or tested by others, CONTRACTOR, at ENGINEER's request, shall uncover, expose, or otherwise make available for observation, inspection, or testing as ENGINEER may require, that portion of the Work in

question, furnishing all necessary labor, material, and equipment. If it is found that such Work is defective, CONTRACTOR shall pay all Claims, costs, losses, and damages (including but not limited to all fees and charges of engineers, architects, attorneys, and other professionals and all court or arbitration or other dispute resolution costs) arising out of or relating to such uncovering, exposure, observation, inspection, and testing, and of satisfactory replacement or reconstruction (including but not limited to all costs of repair or replacement of work of others); and OWNER shall be entitled to an appropriate decrease in the Contract Price. If the parties are unable to agree as to the amount thereof, OWNER may make a Claim therefor as provided in paragraph 10.05. If, however, such Work is not found to be defective, CONTRACTOR shall be allowed an increase in the Contract Price or an extension of the Contract Times (or Milestones), or both, directly attributable to such uncovering, exposure, observation, inspection, testing, replacement, and reconstruction. If the parties are unable to agree as to the amount or extent thereof, CONTRACTOR may make a Claim therefor as provided in paragraph 10.05.

#### 13.05 *OWNER May Stop the Work*

A. If the Work is defective, or CONTRACTOR fails to supply sufficient skilled workers or suitable materials or equipment, or fails to perform the Work in such a way that the completed Work will conform to the Contract Documents, OWNER may order CONTRACTOR to stop the Work, or any portion thereof, until the cause for such order has been eliminated; however, this right of OWNER to stop the Work shall not give rise to any duty on the part of OWNER to exercise this right for the benefit of CONTRACTOR, any Subcontractor, any Supplier, any other individual or entity, or any surety for, or employee or agent of any of them.

#### 13.06 *Correction or Removal of Defective Work*

A. CONTRACTOR shall correct all defective Work, whether or not fabricated, installed, or completed, or, if the Work has been rejected by ENGINEER, remove it from the Project and replace it with Work that is not defective. CONTRACTOR shall pay all Claims, costs, losses, and damages (including but not limited to all fees and charges of engineers, architects, attorneys, and other professionals and all court or arbitration or other dispute resolution costs) arising out of or relating to such correction or removal (including but not limited to all costs of repair or replacement of work of others).

#### 13.07 *Correction Period*

A. If within one year after the date of Substantial Completion or such longer period of time as may be prescribed by Laws or Regulations or by the terms of any applicable special guarantee required by the Contract Documents or by any specific provision of the Contract Documents, any Work is found to be defective, or if the repair of any damages to the land or areas made available for CONTRACTOR's use by OWNER or permitted by Laws and Regulations as contemplated in paragraph 6.11.A is found to be defective, CONTRACTOR shall promptly, without cost to OWNER and in accordance with OWNER's written instructions: (i) repair such defective land or areas, or (ii) correct such defective Work or, if the defective Work has been rejected by OWNER, remove it from the Project and replace it with Work that is not defective, and (iii) satisfactorily correct or repair or remove and replace any damage to other Work, to the work of others or other land or areas resulting therefrom. If CONTRACTOR does not promptly comply with the terms of such instructions, or in an emergency where delay would cause serious risk of loss or damage, OWNER may have the defective Work corrected or repaired or may have the rejected Work removed and replaced, and all Claims, costs, losses, and damages (including but not limited to all fees and charges of engineers, architects, attorneys, and other professionals and all court or arbitration or other dispute resolution costs) arising out of or relating to such correction or repair or such removal and replacement (including but not limited to all costs of repair or replacement of work of others) will be paid by CONTRACTOR.

B. In special circumstances where a particular item of equipment is placed in continuous service before Substantial Completion of all the Work, the correction period for that item may start to run from an earlier date if so provided in the Specifications or by Written Amendment.

C. Where defective Work (and damage to other Work resulting therefrom) has been corrected or removed and replaced under this paragraph 13.07, the correction period hereunder with respect to such Work will be extended for an additional period of one year after such correction or removal and replacement has been satisfactorily completed.

D. CONTRACTOR's obligations under this paragraph 13.07 are in addition to any other obligation or warranty. The provisions of this paragraph 13.07 shall not be construed as a substitute for or a waiver of the provisions of any applicable statute of limitation or repose.

#### 13.08 *Acceptance of Defective Work*

A. If, instead of requiring correction or removal and replacement of defective Work, OWNER (and, prior to ENGINEER's recommendation of final payment, ENGINEER) prefers to accept it, OWNER may do so. CONTRACTOR shall pay all Claims, costs, losses, and damages (including but not limited to all fees and charges of engineers, architects, attorneys, and other professionals and all court or arbitration or other dispute resolution costs) attributable to OWNER's evaluation of and determination to accept such defective Work (such costs to be approved by ENGINEER as to reasonableness) and the diminished value of the Work to the extent not otherwise paid by CONTRACTOR pursuant to this sentence. If any such acceptance occurs prior to ENGINEER's recommendation of final payment, a Change Order will be issued incorporating the necessary revisions in the Contract Documents with respect to the Work, and OWNER shall be entitled to an appropriate decrease in the Contract Price, reflecting the diminished value of Work so accepted. If the parties are unable to agree as to the amount thereof, OWNER may make a Claim therefor as provided in paragraph 10.05. If the acceptance occurs after such recommendation, an appropriate amount will be paid by CONTRACTOR to OWNER.

#### 13.09 *OWNER May Correct Defective Work*

A. If CONTRACTOR fails within a reasonable time after written notice from ENGINEER to correct defective Work or to remove and replace rejected Work as required by ENGINEER in accordance with paragraph 13.06.A, or if CONTRACTOR fails to perform the Work in accordance with the Contract Documents, or if CONTRACTOR fails to comply with any other provision of the Contract Documents, OWNER may, after seven days written notice

to CONTRACTOR, correct and remedy any such deficiency.

B. In exercising the rights and remedies under this paragraph, OWNER shall proceed expeditiously. In connection with such corrective and remedial action, OWNER may exclude CONTRACTOR from all or part of the Site, take possession of all or part of the Work and suspend CONTRACTOR's services related thereto, take possession of CONTRACTOR's tools, appliances, construction equipment and machinery at the Site, and incorporate in the Work all materials and equipment stored at the Site or for which OWNER has paid CONTRACTOR but which are stored elsewhere. CONTRACTOR shall allow OWNER, OWNER's representatives, agents and employees, OWNER's other contractors, and ENGINEER and ENGINEER's Consultants access to the Site to enable OWNER to exercise the rights and remedies under this paragraph.

C. All Claims, costs, losses, and damages (including but not limited to all fees and charges of engineers, architects, attorneys, and other professionals and all court or arbitration or other dispute resolution costs) incurred or sustained by OWNER in exercising the rights and remedies under this paragraph 13.09 will be charged against CONTRACTOR, and a Change Order will be issued incorporating the necessary revisions in the Contract Documents with respect to the Work; and OWNER shall be entitled to an appropriate decrease in the Contract Price. If the parties are unable to agree as to the amount of the adjustment, OWNER may make a Claim therefor as provided in paragraph 10.05. Such claims, costs, losses and damages will include but not be limited to all costs of repair, or replacement of work of others destroyed or damaged by correction, removal, or replacement of CONTRACTOR's defective Work.

D. CONTRACTOR shall not be allowed an extension of the Contract Times (or Milestones) because of any delay in the performance of the Work attributable to the exercise by OWNER of OWNER's rights and remedies under this paragraph 13.09.

ARTICLE 14 - PAYMENTS TO CONTRACTOR AND  
COMPLETION

---

14.01 *Schedule of Values*

A. The schedule of values established as provided in paragraph 2.07.A will serve as the basis for progress payments and will be incorporated into a form of Application for Payment acceptable to ENGINEER. Progress payments on account of Unit Price Work will be based on the number of units completed.

14.02 *Progress Payments*

A. *Applications for Payments*

1. At least 20 days before the date established for each progress payment (but not more often than once a month), CONTRACTOR shall submit to ENGINEER for review an Application for Payment filled out and signed by CONTRACTOR covering the Work completed as of the date of the Application and accompanied by such supporting documentation as is required by the Contract Documents. If payment is requested on the basis of materials and equipment not incorporated in the Work but delivered and suitably stored at the Site or at another location agreed to in writing, the Application for Payment shall also be accompanied by a bill of sale, invoice, or other documentation warranting that OWNER has received the materials and equipment free and clear of all Liens and evidence that the materials and equipment are covered by appropriate property insurance or other arrangements to protect OWNER's interest therein, all of which must be satisfactory to OWNER.

2. Beginning with the second Application for Payment, each Application shall include an affidavit of CONTRACTOR stating that all previous progress payments received on account of the Work have been applied on account to discharge CONTRACTOR's legitimate obligations associated with prior Applications for Payment.

3. The amount of retainage with respect to progress payments will be as stipulated in the Agreement.

B. *Review of Applications*

1. ENGINEER will, within 10 days after receipt of each Application for Payment, either indicate in writing a recommendation of payment and present the Application to OWNER or return the Application to CONTRACTOR indicating in writing ENGINEER's reasons for refusing to recommend payment. In the latter case, CONTRACTOR may make the necessary corrections and resubmit the Application.

2. ENGINEER's recommendation of any payment requested in an Application for Payment will constitute a representation by ENGINEER to OWNER, based on ENGINEER's observations on the Site of the executed Work as an experienced and qualified design professional and on ENGINEER's review of the Application for Payment and the accompanying data and schedules, that to the best of ENGINEER's knowledge, information and belief:

a. the Work has progressed to the point indicated;

b. the quality of the Work is generally in accordance with the Contract Documents (subject to an evaluation of the Work as a functioning whole prior to or upon Substantial Completion, to the results of any subsequent tests called for in the Contract Documents, to a final determination of quantities and classifications for Unit Price Work under paragraph 9.08, and to any other qualifications stated in the recommendation); and

c. the conditions precedent to CONTRACTOR's being entitled to such payment appear to have been fulfilled in so far as it is ENGINEER's responsibility to observe the Work.

3. By recommending any such payment ENGINEER will not thereby be deemed to have represented that: (i) inspections made to check the quality or the quantity of the Work as it has been performed have been exhaustive, extended to every aspect of the Work in progress, or involved detailed inspections of the Work beyond the responsibilities specifically assigned to ENGINEER in the Contract Documents; or (ii) that there may not be other matters or issues between the parties

that might entitle CONTRACTOR to be paid additionally by OWNER or entitle OWNER to withhold payment to CONTRACTOR.

4. Neither ENGINEER's review of CONTRACTOR's Work for the purposes of recommending payments nor ENGINEER's recommendation of any payment, including final payment, will impose responsibility on ENGINEER to supervise, direct, or control the Work or for the means, methods, techniques, sequences, or procedures of construction, or the safety precautions and programs incident thereto, or for CONTRACTOR's failure to comply with Laws and Regulations applicable to CONTRACTOR's performance of the Work. Additionally, said review or recommendation will not impose responsibility on ENGINEER to make any examination to ascertain how or for what purposes CONTRACTOR has used the moneys paid on account of the Contract Price, or to determine that title to any of the Work, materials, or equipment has passed to OWNER free and clear of any Liens.

5. ENGINEER may refuse to recommend the whole or any part of any payment if, in ENGINEER's opinion, it would be incorrect to make the representations to OWNER referred to in paragraph 14.02.B.2. ENGINEER may also refuse to recommend any such payment or, because of subsequently discovered evidence or the results of subsequent inspections or tests, revise or revoke any such payment recommendation previously made, to such extent as may be necessary in ENGINEER's opinion to protect OWNER from loss because:

a. the Work is defective, or completed Work has been damaged, requiring correction or replacement;

b. the Contract Price has been reduced by Written Amendment or Change Orders;

c. OWNER has been required to correct defective Work or complete Work in accordance with paragraph 13.09; or

d. ENGINEER has actual knowledge of the occurrence of any of the events enumerated in paragraph 15.02.A.

#### C. *Payment Becomes Due*

1. Ten days after presentation of the Application, for Payment to OWNER with ENGINEER's recommendation, the amount recommended will (subject to the provisions of paragraph 14.02.D) become due, and when due will be paid by OWNER to CONTRACTOR.

#### D. *Reduction in Payment*

1. OWNER may refuse to make payment of the full amount recommended by ENGINEER because:

a. claims have been made against OWNER on account of CONTRACTOR's performance or furnishing of the Work;

b. Liens have been filed in connection with the Work, except where CONTRACTOR has delivered a specific Bond satisfactory to OWNER to secure the satisfaction and discharge of such Liens;

c. there are other items entitling OWNER to a set-off against the amount recommended; or

d. OWNER has actual knowledge of the occurrence of any of the events enumerated in paragraphs 14.02.B.5.a through 14.02.B.5.c or paragraph 15.02.A.

2. If OWNER refuses to make payment of the full amount recommended by ENGINEER, OWNER must give CONTRACTOR immediate written notice (with a copy to ENGINEER) stating the reasons for such action and promptly pay CONTRACTOR any amount remaining after deduction of the amount so withheld. OWNER shall promptly pay CONTRACTOR the amount so withheld, or any adjustment thereto agreed to by OWNER and CONTRACTOR, when CONTRACTOR corrects to OWNER's satisfaction the reasons for such action.

3. If it is subsequently determined that OWNER's refusal of payment was not justified, the amount wrongfully withheld shall be treated as an amount due as determined by paragraph 14.02.C.1.

#### 14.03 *CONTRACTOR's Warranty of Title*

A. CONTRACTOR warrants and guarantees that title to all Work, materials, and equipment covered by any Application for Payment, whether incorporated in the Project or not, will pass to OWNER no later than the time of payment free and clear of all Liens.

#### 14.04 *Substantial Completion*

A. When CONTRACTOR considers the entire Work ready for its intended use CONTRACTOR shall notify OWNER and ENGINEER in writing that the entire Work is substantially complete (except for items specifically listed by CONTRACTOR as incomplete) and request that ENGINEER issue a certificate of Substantial Completion. Promptly thereafter, OWNER, CONTRACTOR, and ENGINEER shall make an inspection of the Work to determine the status of completion. If ENGINEER does not consider the Work substantially complete, ENGINEER will notify CONTRACTOR in writing giving the reasons therefor. If ENGINEER considers the Work substantially complete, ENGINEER will prepare and deliver to OWNER a tentative certificate of Substantial Completion which shall fix the date of Substantial Completion. There shall be attached to the certificate a tentative list of items to be completed or corrected before final payment. OWNER shall have seven days after receipt of the tentative certificate during which to make written objection to ENGINEER as to any provisions of the certificate or attached list. If, after considering such objections, ENGINEER concludes that the Work is not substantially complete, ENGINEER will within 14 days after submission of the tentative certificate to OWNER notify CONTRACTOR in writing, stating the reasons therefor. If, after consideration of OWNER's objections, ENGINEER considers the Work substantially complete, ENGINEER will within said 14 days execute and deliver to OWNER and CONTRACTOR a definitive certificate of Substantial Completion (with a revised tentative list of items to be completed or corrected) reflecting such changes from the tentative certificate as ENGINEER believes justified after consideration of any objections from OWNER. At the time of delivery of the tentative certificate of Substantial Completion ENGINEER will deliver to OWNER and CONTRACTOR a written recommendation as to division of responsibilities pending final payment between OWNER and CONTRACTOR with respect to security, operation, safety, and protection of the Work, maintenance, heat, utilities, insurance, and warranties and guarantees. Unless OWNER and CONTRACTOR agree otherwise in writing and so inform ENGINEER in writing prior to ENGINEER's issuing the definitive certificate of Substantial Completion,

ENGINEER's aforesaid recommendation will be binding on OWNER and CONTRACTOR until final payment.

B. OWNER shall have the right to exclude CONTRACTOR from the Site after the date of Substantial Completion, but OWNER shall allow CONTRACTOR reasonable access to complete or correct items on the tentative list.

#### 14.05 *Partial Utilization*

A. Use by OWNER at OWNER's option of any substantially completed part of the Work which has specifically been identified in the Contract Documents, or which OWNER, ENGINEER, and CONTRACTOR agree constitutes a separately functioning and usable part of the Work that can be used by OWNER for its intended purpose without significant interference with CONTRACTOR's performance of the remainder of the Work, may be accomplished prior to Substantial Completion of all the Work subject to the following conditions.

1. OWNER at any time may request CONTRACTOR in writing to permit OWNER to use any such part of the Work which OWNER believes to be ready for its intended use and substantially complete. If CONTRACTOR agrees that such part of the Work is substantially complete, CONTRACTOR will certify to OWNER and ENGINEER that such part of the Work is substantially complete and request ENGINEER to issue a certificate of Substantial Completion for that part of the Work. CONTRACTOR at any time may notify OWNER and ENGINEER in writing that CONTRACTOR considers any such part of the Work ready for its intended use and substantially complete and request ENGINEER to issue a certificate of Substantial Completion for that part of the Work. Within a reasonable time after either such request, OWNER, CONTRACTOR, and ENGINEER shall make an inspection of that part of the Work to determine its status of completion. If ENGINEER does not consider that part of the Work to be substantially complete, ENGINEER will notify OWNER and CONTRACTOR in writing giving the reasons therefor. If ENGINEER considers that part of the Work to be substantially complete, the provisions of paragraph 14.04 will apply with respect to certification of Substantial Completion of that part of the Work and the division of responsibility in respect thereof and access thereto.

2. No occupancy or separate operation of part of the Work may occur prior to compliance with the requirements of paragraph 5.10 regarding property insurance.

#### 14.06 *Final Inspection*

A. Upon written notice from CONTRACTOR that the entire Work or an agreed portion thereof is complete, ENGINEER will promptly make a final inspection with OWNER and CONTRACTOR and will notify CONTRACTOR in writing of all particulars in which this inspection reveals that the Work is incomplete or defective. CONTRACTOR shall immediately take such measures as are necessary to complete such Work or remedy such deficiencies.

#### 14.07 *Final Payment*

##### A. *Application for Payment*

1. After CONTRACTOR has, in the opinion of ENGINEER, satisfactorily completed all corrections identified during the final inspection and has delivered, in accordance with the Contract Documents, all maintenance and operating instructions, schedules, guarantees, Bonds, certificates or other evidence of insurance certificates of inspection, marked-up record documents (as provided in paragraph 6.12), and other documents, CONTRACTOR may make application for final payment following the procedure for progress payments.

2. The final Application for Payment shall be accompanied (except as previously delivered) by: (i) all documentation called for in the Contract Documents, including but not limited to the evidence of insurance required by subparagraph 5.04.B.7; (ii) consent of the surety, if any, to final payment; and (iii) complete and legally effective releases or waivers (satisfactory to OWNER) of all Lien rights arising out of or Liens filed in connection with the Work.

3. In lieu of the releases or waivers of Liens specified in paragraph 14.07.A.2 and as approved by OWNER, CONTRACTOR may furnish receipts or releases in full and an affidavit of CONTRACTOR that: (i) the releases and receipts include all labor, services, material, and equipment for which a Lien could be filed; and (ii) all payrolls, material and equipment bills, and other

indebtedness connected with the Work for which OWNER or OWNER's property might in any way be responsible have been paid or otherwise satisfied. If any Subcontractor or Supplier fails to furnish such a release or receipt in full, CONTRACTOR may furnish a Bond or other collateral satisfactory to OWNER to indemnify OWNER against any Lien.

##### B. *Review of Application and Acceptance*

1. If, on the basis of ENGINEER's observation of the Work during construction and final inspection, and ENGINEER's review of the final Application for Payment and accompanying documentation as required by the Contract Documents, ENGINEER is satisfied that the Work has been completed and CONTRACTOR's other obligations under the Contract Documents have been fulfilled, ENGINEER will, within ten days after receipt of the final Application for Payment, indicate in writing ENGINEER's recommendation of payment and present the Application for Payment to OWNER for payment. At the same time ENGINEER will also give written notice to OWNER and CONTRACTOR that the Work is acceptable subject to the provisions of paragraph 14.09. Otherwise, ENGINEER will return the Application for Payment to CONTRACTOR, indicating in writing the reasons for refusing to recommend final payment, in which case CONTRACTOR shall make the necessary corrections and resubmit the Application for Payment.

##### C. *Payment Becomes Due*

1. Thirty days after the presentation to OWNER of the Application for Payment and accompanying documentation, the amount recommended by ENGINEER will become due and, when due, will be paid by OWNER to CONTRACTOR.

#### 14.08 *Final Completion Delayed*

A. If, through no fault of CONTRACTOR, final completion of the Work is significantly delayed, and if ENGINEER so confirms, OWNER shall, upon receipt of CONTRACTOR's final Application for Payment and recommendation of ENGINEER, and without terminating the Agreement, make payment of the balance due for that portion of the Work fully completed and accepted. If the remaining balance to be held by OWNER for Work not

fully completed or corrected is less than the retainage stipulated in the Agreement, and if Bonds have been furnished as required in paragraph 5.01, the written consent of the surety to the payment of the balance due for that portion of the Work fully completed and accepted shall be submitted by CONTRACTOR to ENGINEER with the Application for such payment. Such payment shall be made under the terms and conditions governing final payment, except that it shall not constitute a waiver of Claims.

#### 14.09 *Waiver of Claims*

A. The making and acceptance of final payment will constitute:

1. a waiver of all Claims by OWNER against CONTRACTOR, except Claims arising from unsettled Liens, from defective Work appearing after final inspection pursuant to paragraph 14.06, from failure to comply with the Contract Documents or the terms of any special guarantees specified therein, or from CONTRACTOR's continuing obligations under the Contract Documents; and

2. a waiver of all Claims by CONTRACTOR against OWNER other than those previously made in writing which are still unsettled.

### ARTICLE 15 - SUSPENSION OF WORK AND TERMINATION

---

#### 15.01 OWNER May Suspend Work

A. At any time and without cause, OWNER may suspend the Work or any portion thereof for a period of not more than 90 consecutive days by notice in writing to CONTRACTOR and ENGINEER which will fix the date on which Work will be resumed. CONTRACTOR shall resume the Work on the date so fixed. CONTRACTOR shall be allowed an adjustment in the Contract Price or an extension of the Contract Times, or both, directly attributable to any such suspension if CONTRACTOR makes a Claim therefor as provided in paragraph 10.05.

#### 15.02 *OWNER May Terminate for Cause*

A. The occurrence of any one or more of the following events will justify termination for cause:

1. CONTRACTOR's persistent failure to perform the Work in accordance with the Contract Documents (including, but not limited to, failure to supply sufficient skilled workers or suitable materials or equipment or failure to adhere to the progress schedule established under paragraph 2.07 as adjusted from time to time pursuant to paragraph 6.04);

2. CONTRACTOR's disregard of Laws or Regulations of any public body having jurisdiction;

3. CONTRACTOR's disregard of the authority of ENGINEER; or

4. CONTRACTOR's violation in any substantial way of any provisions of the Contract Documents.

B. If one or more of the events identified in paragraph 15.02.A occur, OWNER may, after giving CONTRACTOR (and the surety, if any) seven days written notice, terminate the services of CONTRACTOR, exclude CONTRACTOR from the Site, and take possession of the Work and of all CONTRACTOR's tools, appliances, construction equipment, and machinery at the Site, and use the same to the full extent they could be used by CONTRACTOR (without liability to CONTRACTOR for trespass or conversion), incorporate in the Work all materials and equipment stored at the Site or for which OWNER has paid CONTRACTOR but which are stored elsewhere, and finish the Work as OWNER may deem expedient. In such case, CONTRACTOR shall not be entitled to receive any further payment until the Work is finished. If the unpaid balance of the Contract Price exceeds all claims, costs, losses, and damages (including but not limited to all fees and charges of engineers, architects, attorneys, and other professionals and all court or arbitration or other dispute resolution costs) sustained by OWNER arising out of or relating to completing the Work, such excess will be paid to CONTRACTOR. If such claims, costs, losses, and damages exceed such unpaid balance, CONTRACTOR shall pay the difference to OWNER. Such claims, costs, losses, and damages incurred by OWNER will be reviewed by ENGINEER as to their reasonableness and, when so approved by ENGINEER, incorporated in a Change Order. When exercising any rights or remedies under this paragraph OWNER shall not be required to obtain the lowest price for the Work performed.

C. Where CONTRACTOR's services have been so terminated by OWNER, the termination will not affect any rights or remedies of OWNER against CONTRACTOR then existing or which may thereafter accrue. Any retention or payment of moneys due CONTRACTOR by OWNER will not release CONTRACTOR from liability.

#### 15.03 *OWNER May Terminate For Convenience*

A. Upon seven days written notice to CONTRACTOR and ENGINEER, OWNER may, without cause and without prejudice to any other right or remedy of OWNER, elect to terminate the Contract. In such case, CONTRACTOR shall be paid (without duplication of any items):

1. for completed and acceptable Work executed in accordance with the Contract Documents prior to the effective date of termination, including fair and reasonable sums for overhead and profit on such Work;

2. for expenses sustained prior to the effective date of termination in performing services and furnishing labor, materials, or equipment as required by the Contract Documents in connection with uncompleted Work, plus fair and reasonable sums for overhead and profit on such expenses;

3. for all claims, costs, losses, and damages (including but not limited to all fees and charges of engineers, architects, attorneys, and other professionals and all court or arbitration or other dispute resolution costs) incurred in settlement of terminated contracts with Subcontractors, Suppliers, and others; and

4. for reasonable expenses directly attributable to termination.

B. CONTRACTOR shall not be paid on account of loss of anticipated profits or revenue or other economic loss arising out of or resulting from such termination.

#### 15.04 *CONTRACTOR May Stop Work or Terminate*

A. If, through no act or fault of CONTRACTOR, the Work is suspended for more than 90 consecutive days by OWNER or under an order of court or other public authority, or ENGINEER fails to act on any Application for Payment within 30 days after it is submitted, or OWNER fails for 30 days to pay CONTRACTOR any sum finally determined to be due, then CONTRACTOR may, upon

seven days written notice to OWNER and ENGINEER, and provided OWNER or ENGINEER do not remedy such suspension or failure within that time, terminate the Contract and recover from OWNER payment on the same terms as provided in paragraph 15.03. In lieu of terminating the Contract and without prejudice to any other right or remedy, if ENGINEER has failed to act on an Application for Payment within 30 days after it is submitted, or OWNER has failed for 30 days to pay CONTRACTOR any sum finally determined to be due, CONTRACTOR may, seven days after written notice to OWNER and ENGINEER, stop the Work until payment is made of all such amounts due CONTRACTOR, including interest thereon. The provisions of this paragraph 15.04 are not intended to preclude CONTRACTOR from making a Claim under paragraph 10.05 for an adjustment in Contract Price or Contract Times or otherwise for expenses or damage directly attributable to CONTRACTOR's stopping the Work as permitted by this paragraph.

### ARTICLE 16 - DISPUTE RESOLUTION

#### 16.01 *Methods and Procedures*

A. Dispute resolution methods and procedures, if any, shall be as set forth in the Supplementary Conditions. If no method and procedure has been set forth, and subject to the provisions of paragraphs 9.09 and 10.05, OWNER and CONTRACTOR may exercise such rights or remedies as either may otherwise have under the Contract Documents or by Laws or Regulations in respect of any dispute.

### ARTICLE 17 - MISCELLANEOUS

---

#### 17.01 *Giving Notice*

A. Whenever any provision of the Contract Documents requires the giving of written notice, it will be deemed to have been validly given if delivered in person to the individual or to a member of the firm or to an officer of the corporation for whom it is intended, or if delivered at or sent by registered or certified mail, postage prepaid, to the last business address known to the giver of the notice.

#### 17.02 *Computation of Times*

A. When any period of time is referred to in the Contract Documents by days, it will be computed to

exclude the first and include the last day of such period. If the last day of any such period falls on a Saturday or Sunday or on a day made a legal holiday by the law of the applicable jurisdiction, such day will be omitted from the computation.

17.03 *Cumulative Remedies*

A. The duties and obligations imposed by these General Conditions and the rights and remedies available hereunder to the parties hereto are in addition to, and are not to be construed in any way as a limitation of, any rights and remedies available to any or all of them which are otherwise imposed or available by Laws or Regulations, by special warranty or guarantee, or by other provisions of the Contract Documents, and the provisions of this paragraph will be as effective as if repeated specifically in the Contract Documents in connection with each particular duty, obligation, right, and remedy to which they apply.

17.04 *Survival of Obligations*

A. All representations, indemnifications, warranties, and guarantees made in, required by, or given in accordance with the Contract Documents, as well as all continuing obligations indicated in the Contract Documents, will survive final payment, completion, and acceptance of the Work or termination or completion of the Agreement.

17.05 *Controlling Law*

A. This Contract is to be governed by the law of the state in which the Project is located.

## SUPPLEMENTAL GENERAL CONDITIONS

These Supplementary Conditions amend or supplement the Standard General Conditions of the Construction Contract (No. 1910-8, 1996 Edition) and other provisions of the Contract Documents as indicated below. All provisions, which are not so amended or supplemental, remain in full force and effect.

The terms used in these Supplementary Conditions will have the meanings indicated in the General Conditions. Additional terms used in these Supplementary Conditions have the meanings indicated below, which are applicable to both the singular and plural thereof.

**SC-6.10** Delete paragraph 6.10 in its entirety and insert the following in its place:

*The owner qualifies for the state and local tax exemption in the purchase of certain materials and equipment. Other exemptions as per 34 TAC §3.287 and related law may apply.*

**SC-11.01** Delete paragraph 11.01 in its entirety.

**SC-11.02** Delete paragraph 11.02 in its entirety.

**SC-12.01B.2 & B.3.** Delete paragraph 12.01B.2 & B.3 in its entirety.

**SC-12.01.C.2** Delete paragraph 12.01.C.2 in its entirety.

**SC Article 14.02 C.1** Replace "Ten days" with "Thirty days" to read as follows: Thirty days after presentation of the Application for Payment to OWNER with ENGINEER'S recommendation, the amount recommended will (subject to the provisions of paragraph 14.02.D) become due, and when due will be paid by OWNER TO CONTRACTOR.

**SC Article 16** Add the following language at the end of the paragraph of Article 16:

*There are no dispute resolution methods and procedures set forth in the Supplemental Conditions:*

THIS PAGE LEFT INTENTIONALLY BLANK

**EXHIBIT "C"**  
**Insurance Requirements**  
**Applicable to the Acquisition of Goods and/or Services**  
**(Other than Professional Services)**

The Bidder awarded the contract shall furnish proof of insurance, which will also include any subcontractor that is subcontracted by the bidder in at least the following limits, to be in place prior to providing any services under this Contract and to continue at all times in force in effect during the term of this Contract and any extension hereof:

1. **Comprehensive General Liability insurance** policy with limits of not less than Five Hundred Thousand Dollar (\$500,000.00) providing additional coverage to all underlying liabilities of County. Policy shall cover, but not be limited to, Bidder's activities in providing the Services for County; all persons, vehicles, equipment connected with providing Services; and theft or loss of Bidder's property.
  2. **Automobile liability insurance** policy, covering all owned, non-owned or hired/leased automobiles, with limits of at least Three Hundred Thousand Dollars (\$300,000.00) per person and Five Hundred Thousand Dollars (\$500,000.00) per occurrence. Coverage should include injury to or death of persons and property damage claims with limits up to five Hundred Thousand (\$500,000.00) arising out of the services provided to County hereunder.
  3. **Uninsured/Underinsured motorist coverage** in an amount equal to the auto liability limits set forth immediately above;
  4. **Workers Compensation Insurance:** Workers Compensation insurance in amounts established by Texas law, unless the Bidder is specifically exempted from the Texas Workers Compensation Act, Texas Labor Code Chapter 401, et. seq. Workers Compensation policies must include other States Endorsement to include TEXAS if the business is domiciled outside the State of Texas.
- *Bidder shall obtain and maintain any and all other insurances which may be necessary in providing the good/service applicable to this procurement or are otherwise required by law.*
  - *Any and all insurance policies shall be in amounts prescribed by law or otherwise specified by the County, but in no event less than the minimum amounts prescribed by law.*

**Additional Insurance Requirements:**

- a. Bidder shall furnish to County certificate(s) of insurance, and all renewals throughout the duration of the Project, issued by the insurer that such insurance is in full force and effect.
- b. Certificates of insurance shall be submitted to County for approval prior to any services being performed by Bidder.
- c. **Hidalgo County will only accept certificates of insurance on an Acord form (as attached hereto).**

**Page 2 of 2: Continuation of Exhibit "C": Insurance Requirements Applicable to the Acquisition of Goods and/or Services (Other than Professional Services)**

- d. For each policy, except Workers' Compensation, Bidder shall name the County as an additional insured.
- e. Each policy of insurance required hereunder shall extend for a period equivalent to, or longer than the term of the Contract, and any insurer hereunder shall be required to give at least thirty (30) days written notice to the County prior to the cancellation of any such coverage on the termination date, or otherwise.
- f. This Contract shall be automatically suspended upon the cancellation, or other termination, of any required policy of insurance hereunder, and such suspension shall continue until evidence of adequate replacement coverage is provided to County. If replacement coverage is not provided within thirty (30) days following suspension of the Contract, this Contract shall automatically terminate.
- g. All insurance policies will be endorsed to provide a waiver of subrogation in favor of the County.
- h. County reserves the right to review the insurance requirements of this section during the effective period of the contract and to require adjustment of insurance coverage and their limits when deemed necessary and prudent by County based upon changes in statutory law, court decisions, or the claims history of the industry as well as the Bidder.
- i. Insurance policies shall be obtained at Bidder's sole expense. County does not maintain and will not obtain insurance of any type to protect Bidder against loss, damage or injury that may in any way result from Bidders performance of the services.
- j. In no event shall the County be liable for any loss, damage to or destruction of any property belonging to the Bidder.
- k. Bidder is responsible for ensuring all required insurance policies are valid for the duration of the contract.
- l. All insurance policies are to be issued by an insurance company authorized to do business in the State of Texas and acceptable to County.
- m. Bidder shall make any other insurance documentation available to County upon request.

<b>ACORD</b>		<b>CERTIFICATE OF INSURANCE</b>	DATE (MM/DD/YY)
PRODUCER	THIS CERTIFICATE IS ISSUED AS A MATTER OF INFORMATION ONLY AND CONFERS NO RIGHTS UPON THE CERTIFICATE HOLDER. THIS CERTIFICATE DOES NOT AMEND, EXTEND OR ALTER THE COVERAGE AFFORDED BY THE POLICIES BELOW.		
INSURED	<b>INSURERS AFFORDING COVERAGE</b>		
	INSURER A:		
	INSURER B:		
	INSURER C:		
	INSURER D:		
			INSURER E:

**COVERAGES**

THE POLICIES OF INSURANCE LISTED BELOW HAVE BEEN ISSUED TO THE INSURED NAMED ABOVE FOR THE POLICY PERIOD INDICATED. NOTWITHSTANDING ANY REQUIREMENT, TERM OR CONDITION OF ANY CONTRACT OR OTHER DOCUMENT WITH RESPECT TO WHICH THIS CERTIFICATE MAY BE ISSUED OR MAY PERTAIN, THE INSURANCE AFFORDED BY THE POLICIES DESCRIBED HEREIN IS SUBJECT TO ALL THEIR TERMS, EXCLUSIONS AND CONDITIONS OF SUCH POLICIES. AGGREGATE LIMITS SHOWN MAY HAVE BEEN REDUCED BY PAID CLAIMS.

INSR LTR	TYPE OF INSURANCE	POLICY NUMBER	POLICY EFFECTIVE DATE (MM/DD/YY)	POLICY EXPIRATION DATE (MM/DD/YY)	LIMITS
A	<b>GENERAL LIABILITY</b>				EACH OCCURRENCE \$
	<input type="checkbox"/> COMMERCIAL GENERAL LIABILITY				FIRE DAMAGE (Any one fire) \$
	<input type="checkbox"/> CLAIMS MADE OCCUR				MEDICAL (Any one person) \$
	<input type="checkbox"/> OWNER'S & CONT. PROT				PERSONAL & ADV INJURY \$
	<input type="checkbox"/> OWNER'S PROTECTIVE LIABILITY				GENERAL AGGREGATE \$
	<input type="checkbox"/> GEN L AGGREGATE LIMIT APPLIES PER:				PRODUCTS - COMP/OP \$
	<input type="checkbox"/> POLICY PROJECT <input type="checkbox"/> LOC				
B	<b>AUTOMOBILE LIABILITY</b>				COMBINED SINGLE LIMIT (Ea accident) \$
	<input type="checkbox"/> ANY AUTO				BODILY INJURY (Per person) \$
	<input type="checkbox"/> ALL OWNED AUTOS				BODILY INJURY (Per accident) \$
	<input type="checkbox"/> SCHEDULED AUTOS				PROPERTY DAMAGE (Per accident) \$
	<input type="checkbox"/> HIRED AUTOS				
<input type="checkbox"/> NON-OWNED AUTOS					
	<b>GARAGE LIABILITY</b>				AUTO ONLY-EA ACCIDENT \$
	<input type="checkbox"/> ANY AUTO				OTHER THAN AUTO ONLY EA ACC AGG \$
C	<b>EXCESS LIABILITY</b>				EACH OCCURRENCE \$
	<input type="checkbox"/> OCCUR <input type="checkbox"/> CLAIMS MADE				AGGREGATE \$
	<input type="checkbox"/> DEDUCTIBLE				\$
	<input type="checkbox"/> RETENTION \$				\$
D	<b>WORKERS COMPENSATION AND EMPLOYER'S LIABILITY</b>				WC STATUTORY LIMITS <input type="checkbox"/> OTHER \$
					E.L. EACH ACCIDENT \$
					E.L. DISEASE-EA EMPLOYEE \$
	<b>OTHER</b>				E.L. DISEASE-POLICY LIMIT \$

DESCRIPTION OF OPERATIONS / LOCATION / VEHICLES / EXCLUSIONS ADDED BY ENDORSEMENT / SPECIAL PROVISIONS  
 County of Hidalgo shall be named as additional insured on all Commercial General Liability policies.

CERTIFICATE HOLDER	ADDITIONAL INSURED; INSURER LETTER:	CANCELLATION
Hidalgo County Attn: Purchasing Department 2812 S Highway Bus. 281 Edinburg, Texas 78539		SHOULD ANY OF THE ABOVE DESCRIBED POLICIES BY CANCELLED BEFORE THE EXPIRATION DATE THEREOF, THE ISSUING INSURER WILL ENDEAVOR TO MAIL <b>30</b> DAYS WRITTEN NOTICE TO THE CERTIFICATE HOLDER NAMED TO THE LEFT, BUT FAILURE TO DO SO SHALL IMPOSE NO OBLIGATION OR LIABILITY OF ANY KIND UPON THE INSURER, ITS AGENTS OR REPRESENTATIVES.
		AUTHORIZED REPRESENTATIVE

## Insurance Requirements Acknowledgment

I, \_\_\_\_\_, authorized representative for \_\_\_\_\_,  
Company/Vendor

hereby acknowledge receipt of the County's required insurance limits. Said requirements:

- will be acquired within 10 working days after notification from Purchasing Department of bid awarded by the Hidalgo County Commissioners' Court;
- will acquire additional amounts required to meet the County's requirements within 10 working days after notification from Purchasing Department of bid award by the Hidalgo County Commissioners' Court; currently carry the following:

Automobile Liability: \$ \_\_\_\_\_ General Liability: \$ \_\_\_\_\_

- have already been met, see attached copy of insurance certificate.

\_\_\_\_\_  
Authorized Representative

\_\_\_\_\_  
Date

### **NOTICE TO BIDDER:**

A certificate of insurance for the required insurance limits shall be provided to the Purchasing Department's Contract Managers in order to qualify for award of bid and to execute a contract between your Company and the County.

Failure to provide Certificates of Insurance to the Purchasing Department's Contract Managers will cause the bid award to be rescinded and re-awarded to next lowest bidder. Certificates of Insurance will be monitored and verified on a **quarterly basis** to ensure coverage policy is in place. It is the Company's obligation to maintain the appropriate insurance coverage throughout the term of the contract.

**THIS FORM MUST ACCOMPANY BID PACKET**

## PROJECT REQUIREMENTS ACKNOWLEDGMENT

This is to certify that I, \_\_\_\_\_, possess all of the APPLICABLE:

1. Licenses: \_\_\_\_\_.
2. Bond (if applicable) \_\_\_\_\_.
3. Certificates: \_\_\_\_\_.
4. Permits: \_\_\_\_\_.
5. Other: \_\_\_\_\_.

necessary to carry out the required project. Furthermore, I am providing copies of the required documentation so that, if my company is awarded this bid, I may be eligible to enter into a contract with Hidalgo County and proceed to complete the project in a timely manner.

\* Any licenses, bonds (if applicable), certificates, permits, etc. which are required must be presented as part of the bid packet in order to expedite the bid evaluation process.

Authorized Signature	Date
Company	
Address	
City, State, Zip	

**THIS FORM MUST ACCOMPANY BID PACKET**

# EXHIBIT "D"

CIQ

Conflict of Interest

Questionnaire

# CONFLICT OF INTEREST QUESTIONNAIRE

For vendor doing business with local governmental entity

## FORM CIQ

This questionnaire reflects changes made to the law by H.B. 23, 84th Leg., Regular Session.

This questionnaire is being filed in accordance with Chapter 176, Local Government Code, by a vendor who has a business relationship as defined by Section 176.001(1-a) with a local governmental entity and the vendor meets requirements under Section 176.006(a).

By law this questionnaire must be filed with the records administrator of the local governmental entity not later than the 7th business day after the date the vendor becomes aware of facts that require the statement to be filed. See Section 176.006(a-1), Local Government Code.

A vendor commits an offense if the vendor knowingly violates Section 176.006, Local Government Code. An offense under this section is a misdemeanor.

### OFFICE USE ONLY

Date Received

1 Name of vendor who has a business relationship with local governmental entity.

2  Check this box if you are filing an update to a previously filed questionnaire. (The law requires that you file an updated completed questionnaire with the appropriate filing authority not later than the 7th business day after the date on which you became aware that the originally filed questionnaire was incomplete or inaccurate.)

3 Name of local government officer about whom the information is being disclosed.

\_\_\_\_\_  
Name of Officer

4 Describe each employment or other business relationship with the local government officer, or a family member of the officer, as described by Section 176.003(a)(2)(A). Also describe any family relationship with the local government officer. Complete subparts A and B for each employment or business relationship described. Attach additional pages to this Form CIQ as necessary.

A. Is the local government officer or a family member of the officer receiving or likely to receive taxable income, other than investment income, from the vendor?

Yes  No

B. Is the vendor receiving or likely to receive taxable income, other than investment income, from or at the direction of the local government officer or a family member of the officer AND the taxable income is not received from the local governmental entity?

Yes  No

5 Describe each employment or business relationship that the vendor named in Section 1 maintains with a corporation or other business entity with respect to which the local government officer serves as an officer or director, or holds an ownership interest of one percent or more.

6  Check this box if the vendor has given the local government officer or a family member of the officer one or more gifts as described in Section 176.003(a)(2)(B), excluding gifts described in Section 176.003(a-1).

7

\_\_\_\_\_  
Signature of vendor doing business with the governmental entity

\_\_\_\_\_  
Date

## CONFLICT OF INTEREST QUESTIONNAIRE

### For vendor doing business with local governmental entity

A complete copy of Chapter 176 of the Local Government Code may be found at <http://www.statutes.legis.state.tx.us/Docs/LG/htm/LG.176.htm>. For easy reference, below are some of the sections cited on this form.

**Local Government Code § 176.001(1-a):** "Business relationship" means a connection between two or more parties based on commercial activity of one of the parties. The term does not include a connection based on:

- (A) a transaction that is subject to rate or fee regulation by a federal, state, or local governmental entity or an agency of a federal, state, or local governmental entity;
- (B) a transaction conducted at a price and subject to terms available to the public; or
- (C) a purchase or lease of goods or services from a person that is chartered by a state or federal agency and that is subject to regular examination by, and reporting to, that agency.

**Local Government Code § 176.003(a)(2)(A) and (B):**

(a) A local government officer shall file a conflicts disclosure statement with respect to a vendor if:

\*\*\*

(2) the vendor:

(A) has an employment or other business relationship with the local government officer or a family member of the officer that results in the officer or family member receiving taxable income, other than investment income, that exceeds \$2,500 during the 12-month period preceding the date that the officer becomes aware that

(i) a contract between the local governmental entity and vendor has been executed;

or

(ii) the local governmental entity is considering entering into a contract with the vendor;

(B) has given to the local government officer or a family member of the officer one or more gifts that have an aggregate value of more than \$100 in the 12-month period preceding the date the officer becomes aware that:

- (i) a contract between the local governmental entity and vendor has been executed; or
- (ii) the local governmental entity is considering entering into a contract with the vendor.

**Local Government Code § 176.006(a) and (a-1)**

(a) A vendor shall file a completed conflict of interest questionnaire if the vendor has a business relationship with a local governmental entity and:

(1) has an employment or other business relationship with a local government officer of that local governmental entity, or a family member of the officer, described by Section 176.003(a)(2)(A);

(2) has given a local government officer of that local governmental entity, or a family member of the officer, one or more gifts with the aggregate value specified by Section 176.003(a)(2)(B), excluding any gift described by Section 176.003(a-1); or

(3) has a family relationship with a local government officer of that local governmental entity.

(a-1) The completed conflict of interest questionnaire must be filed with the appropriate records administrator not later than the seventh business day after the later of:

(1) the date that the vendor:

(A) begins discussions or negotiations to enter into a contract with the local governmental entity; or

(B) submits to the local governmental entity an application, response to a request for proposals or bids, correspondence, or another writing related to a potential contract with the local governmental entity; or

(2) the date the vendor becomes aware:

(A) of an employment or other business relationship with a local government officer, or a family member of the officer, described by Subsection (a);

(B) that the vendor has given one or more gifts described by Subsection (a); or

(C) of a family relationship with a local government officer.

# **Exhibit "E"**

## **Vendor/Bidder Application W9 HUB/DBE**



**HISTORICALLY UNDERUTILIZED BUSINESS (HUB) DECLARATION**

The primary objective of the Hidalgo County HUB Program is to ensure Historically Underutilized Businesses receive a fair and equal opportunity for participation in the County's procurement process. This fact holds true for Services (Professional & Non-Professional), Commodities, and Construction contracts and any subcontracts thereto. The program strongly encourages Prime Contractors to provide subcontracting opportunities to Certified Hub Contractors/Vendors. Our goal for HUB contractor/vendor participation, as well as HUB subcontractor participation is 30%. To be considered as a "Certified HUB Contractor/Vendor" the contractor/vendor must have been certified by, and hold a current and valid certification with any of the three agencies listed below.

Have you been Certified as a HUB or an MBE/WBE source?:  Yes  No

If yes, by whom?:  Texas Building & Procurement Commission  Other \_\_\_\_\_

Indicate Certification No(s): \_\_\_\_\_ or Are Certificate(s) Attached?:  Yes  No

---

**LIST OF CERTIFIED HUB SUBCONTRACTORS**

(Attach additional pages if necessary)

What percentage of the Bid, RFP, or RFQ is to be subcontracted with Certified HUB sources?: \_\_\_\_\_ %  
(List HUB Subcontractor information below).

HUB Subcontractor Name: \_\_\_\_\_ HUB Status: \_\_\_\_\_  
Certifying Agency (Check all applicable):  Texas Building & Procurement Commission  Other  
Address: \_\_\_\_\_ City: \_\_\_\_\_ State: \_\_\_\_\_ Zip: \_\_\_\_\_  
Contact Person: \_\_\_\_\_ Title: \_\_\_\_\_ Phone No.: ( ) \_\_\_\_\_  
Subcontract Amount: \$ \_\_\_\_\_ Description of Work to be Performed: \_\_\_\_\_

---

HUB Subcontractor Name: \_\_\_\_\_ HUB Status: \_\_\_\_\_  
Certifying Agency (Check all applicable):  Texas Building & Procurement Commission  Other  
Address: \_\_\_\_\_ City: \_\_\_\_\_ State: \_\_\_\_\_ Zip: \_\_\_\_\_  
Contact Person: \_\_\_\_\_ Title: \_\_\_\_\_ Phone No.: ( ) \_\_\_\_\_  
Subcontract Amount: \$ \_\_\_\_\_ Description of Work to be Performed: \_\_\_\_\_

---

HUB Subcontractor Name: \_\_\_\_\_ HUB Status: \_\_\_\_\_  
Certifying Agency (Check all applicable):  Texas Building & Procurement Commission  Other  
Address: \_\_\_\_\_ City: \_\_\_\_\_ State: \_\_\_\_\_ Zip: \_\_\_\_\_  
Contact Person: \_\_\_\_\_ Title: \_\_\_\_\_ Phone No.: ( ) \_\_\_\_\_  
Subcontract Amount: \$ \_\_\_\_\_ Description of Work to be Performed: \_\_\_\_\_

---

# Request for Taxpayer Identification Number and Certification

**Give Form to the  
requester. Do not  
send to the IRS.**

▶ Go to [www.irs.gov/FormW9](http://www.irs.gov/FormW9) for instructions and the latest information.

Print or type.  
See Specific Instructions on page 3.

<b>1</b> Name (as shown on your income tax return). Name is required on this line; do not leave this line blank.	
<b>2</b> Business name/disregarded entity name, if different from above	
<b>3</b> Check appropriate box for federal tax classification of the person whose name is entered on line 1. Check only <b>one</b> of the following seven boxes.	<b>4</b> Exemptions (codes apply only to certain entities, not individuals; see instructions on page 3):
<input type="checkbox"/> Individual/sole proprietor or single-member LLC <input type="checkbox"/> C Corporation <input type="checkbox"/> S Corporation <input type="checkbox"/> Partnership <input type="checkbox"/> Trust/estate	Exempt payee code (if any) _____  Exemption from FATCA reporting code (if any) _____  <i>(Applies to accounts maintained outside the U.S.)</i>
<input type="checkbox"/> Limited liability company. Enter the tax classification (C=C corporation, S=S corporation, P=Partnership) ▶ _____ <b>Note:</b> Check the appropriate box in the line above for the tax classification of the single-member owner. Do not check LLC if the LLC is classified as a single-member LLC that is disregarded from the owner unless the owner of the LLC is another LLC that is <b>not</b> disregarded from the owner for U.S. federal tax purposes. Otherwise, a single-member LLC that is disregarded from the owner should check the appropriate box for the tax classification of its owner.	
<input type="checkbox"/> Other (see instructions) ▶ _____	
<b>5</b> Address (number, street, and apt. or suite no.) See instructions.	Requester's name and address (optional)
<b>6</b> City, state, and ZIP code	
<b>7</b> List account number(s) here (optional)	

### Part I Taxpayer Identification Number (TIN)

Enter your TIN in the appropriate box. The TIN provided must match the name given on line 1 to avoid backup withholding. For individuals, this is generally your social security number (SSN). However, for a resident alien, sole proprietor, or disregarded entity, see the instructions for Part I, later. For other entities, it is your employer identification number (EIN). If you do not have a number, see *How to get a TIN*, later.

**Note:** If the account is in more than one name, see the instructions for line 1. Also see *What Name and Number To Give the Requester* for guidelines on whose number to enter.

<b>Social security number</b>												
<table style="width: 100%; border-collapse: collapse;"> <tr> <td style="border: 1px solid black; width: 25px; height: 25px;"></td> <td style="border: 1px solid black; width: 25px; height: 25px;"></td> <td style="border: 1px solid black; width: 25px; height: 25px;"></td> <td style="border: 1px solid black; width: 25px; height: 25px;"></td> <td style="border: 1px solid black; width: 25px; height: 25px;"></td> <td style="border: 1px solid black; width: 25px; height: 25px;"></td> <td style="border: 1px solid black; width: 25px; height: 25px;"></td> <td style="border: 1px solid black; width: 25px; height: 25px;"></td> <td style="border: 1px solid black; width: 25px; height: 25px;"></td> <td style="border: 1px solid black; width: 25px; height: 25px;"></td> <td style="border: 1px solid black; width: 25px; height: 25px;"></td> <td style="border: 1px solid black; width: 25px; height: 25px;"></td> </tr> </table>												
<b>or</b>												
<b>Employer identification number</b>												
<table style="width: 100%; border-collapse: collapse;"> <tr> <td style="border: 1px solid black; width: 25px; height: 25px;"></td> <td style="border: 1px solid black; width: 25px; height: 25px;"></td> <td style="border: 1px solid black; width: 25px; height: 25px;"></td> <td style="border: 1px solid black; width: 25px; height: 25px;"></td> <td style="border: 1px solid black; width: 25px; height: 25px;"></td> <td style="border: 1px solid black; width: 25px; height: 25px;"></td> <td style="border: 1px solid black; width: 25px; height: 25px;"></td> <td style="border: 1px solid black; width: 25px; height: 25px;"></td> <td style="border: 1px solid black; width: 25px; height: 25px;"></td> <td style="border: 1px solid black; width: 25px; height: 25px;"></td> <td style="border: 1px solid black; width: 25px; height: 25px;"></td> <td style="border: 1px solid black; width: 25px; height: 25px;"></td> </tr> </table>												

### Part II Certification

Under penalties of perjury, I certify that:

1. The number shown on this form is my correct taxpayer identification number (or I am waiting for a number to be issued to me); and
2. I am not subject to backup withholding because: (a) I am exempt from backup withholding, or (b) I have not been notified by the Internal Revenue Service (IRS) that I am subject to backup withholding as a result of a failure to report all interest or dividends, or (c) the IRS has notified me that I am no longer subject to backup withholding; and
3. I am a U.S. citizen or other U.S. person (defined below); and
4. The FATCA code(s) entered on this form (if any) indicating that I am exempt from FATCA reporting is correct.

**Certification instructions.** You must cross out item 2 above if you have been notified by the IRS that you are currently subject to backup withholding because you have failed to report all interest and dividends on your tax return. For real estate transactions, item 2 does not apply. For mortgage interest paid, acquisition or abandonment of secured property, cancellation of debt, contributions to an individual retirement arrangement (IRA), and generally, payments other than interest and dividends, you are not required to sign the certification, but you must provide your correct TIN. See the instructions for Part II, later.

**Sign Here**

Signature of U.S. person ▶

Date ▶

## General Instructions

Section references are to the Internal Revenue Code unless otherwise noted.

**Future developments.** For the latest information about developments related to Form W-9 and its instructions, such as legislation enacted after they were published, go to [www.irs.gov/FormW9](http://www.irs.gov/FormW9).

### Purpose of Form

An individual or entity (Form W-9 requester) who is required to file an information return with the IRS must obtain your correct taxpayer identification number (TIN) which may be your social security number (SSN), individual taxpayer identification number (ITIN), adoption taxpayer identification number (ATIN), or employer identification number (EIN), to report on an information return the amount paid to you, or other amount reportable on an information return. Examples of information returns include, but are not limited to, the following.

- Form 1099-INT (interest earned or paid)

- Form 1099-DIV (dividends, including those from stocks or mutual funds)
- Form 1099-MISC (various types of income, prizes, awards, or gross proceeds)
- Form 1099-B (stock or mutual fund sales and certain other transactions by brokers)
- Form 1099-S (proceeds from real estate transactions)
- Form 1099-K (merchant card and third party network transactions)
- Form 1098 (home mortgage interest), 1098-E (student loan interest), 1098-T (tuition)
- Form 1099-C (canceled debt)
- Form 1099-A (acquisition or abandonment of secured property)

Use Form W-9 only if you are a U.S. person (including a resident alien), to provide your correct TIN.

*If you do not return Form W-9 to the requester with a TIN, you might be subject to backup withholding. See What is backup withholding, later.*

By signing the filled-out form, you:

1. Certify that the TIN you are giving is correct (or you are waiting for a number to be issued),
2. Certify that you are not subject to backup withholding, or
3. Claim exemption from backup withholding if you are a U.S. exempt payee. If applicable, you are also certifying that as a U.S. person, your allocable share of any partnership income from a U.S. trade or business is not subject to the withholding tax on foreign partners' share of effectively connected income, and
4. Certify that FATCA code(s) entered on this form (if any) indicating that you are exempt from the FATCA reporting, is correct. See *What Is FATCA reporting*, later, for further information.

**Note:** If you are a U.S. person and a requester gives you a form other than Form W-9 to request your TIN, you must use the requester's form if it is substantially similar to this Form W-9.

**Definition of a U.S. person.** For federal tax purposes, you are considered a U.S. person if you are:

- An individual who is a U.S. citizen or U.S. resident alien;
- A partnership, corporation, company, or association created or organized in the United States or under the laws of the United States;
- An estate (other than a foreign estate); or
- A domestic trust (as defined in Regulations section 301.7701-7).

**Special rules for partnerships.** Partnerships that conduct a trade or business in the United States are generally required to pay a withholding tax under section 1446 on any foreign partners' share of effectively connected taxable income from such business. Further, in certain cases where a Form W-9 has not been received, the rules under section 1446 require a partnership to presume that a partner is a foreign person, and pay the section 1446 withholding tax. Therefore, if you are a U.S. person that is a partner in a partnership conducting a trade or business in the United States, provide Form W-9 to the partnership to establish your U.S. status and avoid section 1446 withholding on your share of partnership income.

In the cases below, the following person must give Form W-9 to the partnership for purposes of establishing its U.S. status and avoiding withholding on its allocable share of net income from the partnership conducting a trade or business in the United States.

- In the case of a disregarded entity with a U.S. owner, the U.S. owner of the disregarded entity and not the entity;
- In the case of a grantor trust with a U.S. grantor or other U.S. owner, generally, the U.S. grantor or other U.S. owner of the grantor trust and not the trust; and
- In the case of a U.S. trust (other than a grantor trust), the U.S. trust (other than a grantor trust) and not the beneficiaries of the trust.

**Foreign person.** If you are a foreign person or the U.S. branch of a foreign bank that has elected to be treated as a U.S. person, do not use Form W-9. Instead, use the appropriate Form W-8 or Form 8233 (see Pub. 515, *Withholding of Tax on Nonresident Aliens and Foreign Entities*).

**Nonresident alien who becomes a resident alien.** Generally, only a nonresident alien individual may use the terms of a tax treaty to reduce or eliminate U.S. tax on certain types of income. However, most tax treaties contain a provision known as a "saving clause." Exceptions specified in the saving clause may permit an exemption from tax to continue for certain types of income even after the payee has otherwise become a U.S. resident alien for tax purposes.

If you are a U.S. resident alien who is relying on an exception contained in the saving clause of a tax treaty to claim an exemption from U.S. tax on certain types of income, you must attach a statement to Form W-9 that specifies the following five items.

1. The treaty country. Generally, this must be the same treaty under which you claimed exemption from tax as a nonresident alien.
2. The treaty article addressing the income.
3. The article number (or location) in the tax treaty that contains the saving clause and its exceptions.
4. The type and amount of income that qualifies for the exemption from tax.
5. Sufficient facts to justify the exemption from tax under the terms of the treaty article.

**Example.** Article 20 of the U.S.-China income tax treaty allows an exemption from tax for scholarship income received by a Chinese student temporarily present in the United States. Under U.S. law, this student will become a resident alien for tax purposes if his or her stay in the United States exceeds 5 calendar years. However, paragraph 2 of the first Protocol to the U.S.-China treaty (dated April 30, 1984) allows the provisions of Article 20 to continue to apply even after the Chinese student becomes a resident alien of the United States. A Chinese student who qualifies for this exception (under paragraph 2 of the first protocol) and is relying on this exception to claim an exemption from tax on his or her scholarship or fellowship income would attach to Form W-9 a statement that includes the information described above to support that exemption.

If you are a nonresident alien or a foreign entity, give the requester the appropriate completed Form W-8 or Form 8233.

## Backup Withholding

**What is backup withholding?** Persons making certain payments to you must under certain conditions withhold and pay to the IRS 24% of such payments. This is called "backup withholding." Payments that may be subject to backup withholding include interest, tax-exempt interest, dividends, broker and barter exchange transactions, rents, royalties, nonemployee pay, payments made in settlement of payment card and third party network transactions, and certain payments from fishing boat operators. Real estate transactions are not subject to backup withholding.

You will not be subject to backup withholding on payments you receive if you give the requester your correct TIN, make the proper certifications, and report all your taxable interest and dividends on your tax return.

**Payments you receive will be subject to backup withholding if:**

1. You do not furnish your TIN to the requester,
2. You do not certify your TIN when required (see the Instructions for Part II for details),
3. The IRS tells the requester that you furnished an incorrect TIN,
4. The IRS tells you that you are subject to backup withholding because you did not report all your interest and dividends on your tax return (for reportable interest and dividends only), or
5. You do not certify to the requester that you are not subject to backup withholding under 4 above (for reportable interest and dividend accounts opened after 1983 only).

Certain payees and payments are exempt from backup withholding. See *Exempt payee code*, later, and the separate Instructions for the Requester of Form W-9 for more information.

Also see *Special rules for partnerships*, earlier.

## What is FATCA Reporting?

The Foreign Account Tax Compliance Act (FATCA) requires a participating foreign financial institution to report all United States account holders that are specified United States persons. Certain payees are exempt from FATCA reporting. See *Exemption from FATCA reporting code*, later, and the Instructions for the Requester of Form W-9 for more information.

## Updating Your Information

You must provide updated information to any person to whom you claimed to be an exempt payee if you are no longer an exempt payee and anticipate receiving reportable payments in the future from this person. For example, you may need to provide updated information if you are a C corporation that elects to be an S corporation, or if you no longer are tax exempt. In addition, you must furnish a new Form W-9 if the name or TIN changes for the account; for example, if the grantor of a grantor trust dies.

## Penalties

**Failure to furnish TIN.** If you fail to furnish your correct TIN to a requester, you are subject to a penalty of \$50 for each such failure unless your failure is due to reasonable cause and not to willful neglect.

**Civil penalty for false information with respect to withholding.** If you make a false statement with no reasonable basis that results in no backup withholding, you are subject to a \$500 penalty.

**Criminal penalty for falsifying information.** Willfully falsifying certifications or affirmations may subject you to criminal penalties including fines and/or imprisonment.

**Misuse of TINs.** If the requester discloses or uses TINs in violation of federal law, the requester may be subject to civil and criminal penalties.

## Specific Instructions

### Line 1

You must enter one of the following on this line; **do not** leave this line blank. The name should match the name on your tax return.

If this Form W-9 is for a joint account (other than an account maintained by a foreign financial institution (FFI)), list first, and then circle, the name of the person or entity whose number you entered in Part I of Form W-9. If you are providing Form W-9 to an FFI to document a joint account, each holder of the account that is a U.S. person must provide a Form W-9.

a. **Individual.** Generally, enter the name shown on your tax return. If you have changed your last name without informing the Social Security Administration (SSA) of the name change, enter your first name, the last name as shown on your social security card, and your new last name.

**Note: ITIN applicant:** Enter your individual name as it was entered on your Form W-7 application, line 1a. This should also be the same as the name you entered on the Form 1040/1040A/1040EZ you filed with your application.

b. **Sole proprietor or single-member LLC.** Enter your individual name as shown on your 1040/1040A/1040EZ on line 1. You may enter your business, trade, or "doing business as" (DBA) name on line 2.

c. **Partnership, LLC that is not a single-member LLC, C corporation, or S corporation.** Enter the entity's name as shown on the entity's tax return on line 1 and any business, trade, or DBA name on line 2.

d. **Other entities.** Enter your name as shown on required U.S. federal tax documents on line 1. This name should match the name shown on the charter or other legal document creating the entity. You may enter any business, trade, or DBA name on line 2.

e. **Disregarded entity.** For U.S. federal tax purposes, an entity that is disregarded as an entity separate from its owner is treated as a "disregarded entity." See Regulations section 301.7701-2(c)(2)(iii). Enter the owner's name on line 1. The name of the entity entered on line 1 should never be a disregarded entity. The name on line 1 should be the name shown on the income tax return on which the income should be reported. For example, if a foreign LLC that is treated as a disregarded entity for U.S. federal tax purposes has a single owner that is a U.S. person, the U.S. owner's name is required to be provided on line 1. If the direct owner of the entity is also a disregarded entity, enter the first owner that is not disregarded for federal tax purposes. Enter the disregarded entity's name on line 2, "Business name/disregarded entity name." If the owner of the disregarded entity is a foreign person, the owner must complete an appropriate Form W-8 instead of a Form W-9. This is the case even if the foreign person has a U.S. TIN.

### Line 2

If you have a business name, trade name, DBA name, or disregarded entity name, you may enter it on line 2.

### Line 3

Check the appropriate box on line 3 for the U.S. federal tax classification of the person whose name is entered on line 1. Check only one box on line 3.

IF the entity/person on line 1 is a(n) . . .	THEN check the box for . . .
• Corporation	Corporation
• Individual • Sole proprietorship, or • Single-member limited liability company (LLC) owned by an individual and disregarded for U.S. federal tax purposes.	Individual/sole proprietor or single-member LLC
• LLC treated as a partnership for U.S. federal tax purposes, • LLC that has filed Form 8832 or 2553 to be taxed as a corporation, or • LLC that is disregarded as an entity separate from its owner but the owner is another LLC that is not disregarded for U.S. federal tax purposes.	Limited liability company and enter the appropriate tax classification. (P= Partnership; C= C corporation; or S= S corporation)
• Partnership	Partnership
• Trust/estate	Trust/estate

### Line 4, Exemptions

If you are exempt from backup withholding and/or FATCA reporting, enter in the appropriate space on line 4 any code(s) that may apply to you.

#### Exempt payee code.

- Generally, individuals (including sole proprietors) are not exempt from backup withholding.
- Except as provided below, corporations are exempt from backup withholding for certain payments, including interest and dividends.
- Corporations are not exempt from backup withholding for payments made in settlement of payment card or third party network transactions.
- Corporations are not exempt from backup withholding with respect to attorneys' fees or gross proceeds paid to attorneys, and corporations that provide medical or health care services are not exempt with respect to payments reportable on Form 1099-MISC.

The following codes identify payees that are exempt from backup withholding. Enter the appropriate code in the space in line 4.

- 1—An organization exempt from tax under section 501(a), any IRA, or a custodial account under section 403(b)(7) if the account satisfies the requirements of section 401(f)(2)
- 2—The United States or any of its agencies or instrumentalities
- 3—A state, the District of Columbia, a U.S. commonwealth or possession, or any of their political subdivisions or instrumentalities
- 4—A foreign government or any of its political subdivisions, agencies, or instrumentalities
- 5—A corporation
- 6—A dealer in securities or commodities required to register in the United States, the District of Columbia, or a U.S. commonwealth or possession
- 7—A futures commission merchant registered with the Commodity Futures Trading Commission
- 8—A real estate investment trust
- 9—An entity registered at all times during the tax year under the Investment Company Act of 1940
- 10—A common trust fund operated by a bank under section 584(a)
- 11—A financial institution
- 12—A middleman known in the investment community as a nominee or custodian
- 13—A trust exempt from tax under section 664 or described in section 4947

The following chart shows types of payments that may be exempt from backup withholding. The chart applies to the exempt payees listed above, 1 through 13.

IF the payment is for . . .	THEN the payment is exempt for . . .
Interest and dividend payments	All exempt payees except for 7
Broker transactions	Exempt payees 1 through 4 and 6 through 11 and all C corporations. S corporations must not enter an exempt payee code because they are exempt only for sales of noncovered securities acquired prior to 2012.
Barter exchange transactions and patronage dividends	Exempt payees 1 through 4
Payments over \$600 required to be reported and direct sales over \$5,000 <sup>1</sup>	Generally, exempt payees 1 through 5 <sup>2</sup>
Payments made in settlement of payment card or third party network transactions	Exempt payees 1 through 4

<sup>1</sup> See Form 1099-MISC, Miscellaneous Income, and its instructions.

<sup>2</sup> However, the following payments made to a corporation and reportable on Form 1099-MISC are not exempt from backup withholding: medical and health care payments, attorneys' fees, gross proceeds paid to an attorney reportable under section 6045(f), and payments for services paid by a federal executive agency.

**Exemption from FATCA reporting code.** The following codes identify payees that are exempt from reporting under FATCA. These codes apply to persons submitting this form for accounts maintained outside of the United States by certain foreign financial institutions. Therefore, if you are only submitting this form for an account you hold in the United States, you may leave this field blank. Consult with the person requesting this form if you are uncertain if the financial institution is subject to these requirements. A requester may indicate that a code is not required by providing you with a Form W-9 with "Not Applicable" (or any similar indication) written or printed on the line for a FATCA exemption code.

A—An organization exempt from tax under section 501(a) or any individual retirement plan as defined in section 7701(a)(37)

B—The United States or any of its agencies or instrumentalities

C—A state, the District of Columbia, a U.S. commonwealth or possession, or any of their political subdivisions or instrumentalities

D—A corporation the stock of which is regularly traded on one or more established securities markets, as described in Regulations section 1.1472-1(c)(1)(i)

E—A corporation that is a member of the same expanded affiliated group as a corporation described in Regulations section 1.1472-1(c)(1)(i)

F—A dealer in securities, commodities, or derivative financial instruments (including notional principal contracts, futures, forwards, and options) that is registered as such under the laws of the United States or any state

G—A real estate investment trust

H—A regulated investment company as defined in section 851 or an entity registered at all times during the tax year under the Investment Company Act of 1940

I—A common trust fund as defined in section 584(a)

J—A bank as defined in section 581

K—A broker

L—A trust exempt from tax under section 664 or described in section 4947(a)(1)

M—A tax exempt trust under a section 403(b) plan or section 457(g) plan

**Note:** You may wish to consult with the financial institution requesting this form to determine whether the FATCA code and/or exempt payee code should be completed.

### Line 5

Enter your address (number, street, and apartment or suite number). This is where the requester of this Form W-9 will mail your information returns. If this address differs from the one the requester already has on file, write NEW at the top. If a new address is provided, there is still a chance the old address will be used until the payor changes your address in their records.

### Line 6

Enter your city, state, and ZIP code.

## Part I. Taxpayer Identification Number (TIN)

**Enter your TIN in the appropriate box.** If you are a resident alien and you do not have and are not eligible to get an SSN, your TIN is your IRS individual taxpayer identification number (ITIN). Enter it in the social security number box. If you do not have an ITIN, see *How to get a TIN* below.

If you are a sole proprietor and you have an EIN, you may enter either your SSN or EIN.

If you are a single-member LLC that is disregarded as an entity separate from its owner, enter the owner's SSN (or EIN, if the owner has one). Do not enter the disregarded entity's EIN. If the LLC is classified as a corporation or partnership, enter the entity's EIN.

**Note:** See *What Name and Number To Give the Requester*, later, for further clarification of name and TIN combinations.

**How to get a TIN.** If you do not have a TIN, apply for one immediately. To apply for an SSN, get Form SS-5, Application for a Social Security Card, from your local SSA office or get this form online at [www.SSA.gov](http://www.SSA.gov). You may also get this form by calling 1-800-772-1213. Use Form W-7, Application for IRS Individual Taxpayer Identification Number, to apply for an ITIN, or Form SS-4, Application for Employer Identification Number, to apply for an EIN. You can apply for an EIN online by accessing the IRS website at [www.irs.gov/Businesses](http://www.irs.gov/Businesses) and clicking on Employer Identification Number (EIN) under Starting a Business. Go to [www.irs.gov/Forms](http://www.irs.gov/Forms) to view, download, or print Form W-7 and/or Form SS-4. Or, you can go to [www.irs.gov/OrderForms](http://www.irs.gov/OrderForms) to place an order and have Form W-7 and/or SS-4 mailed to you within 10 business days.

If you are asked to complete Form W-9 but do not have a TIN, apply for a TIN and write "Applied For" in the space for the TIN, sign and date the form, and give it to the requester. For interest and dividend payments, and certain payments made with respect to readily tradable instruments, generally you will have 60 days to get a TIN and give it to the requester before you are subject to backup withholding on payments. The 60-day rule does not apply to other types of payments. You will be subject to backup withholding on all such payments until you provide your TIN to the requester.

**Note:** Entering "Applied For" means that you have already applied for a TIN or that you intend to apply for one soon.

**Caution:** A disregarded U.S. entity that has a foreign owner must use the appropriate Form W-8.

## Part II. Certification

To establish to the withholding agent that you are a U.S. person, or resident alien, sign Form W-9. You may be requested to sign by the withholding agent even if item 1, 4, or 5 below indicates otherwise.

For a joint account, only the person whose TIN is shown in Part I should sign (when required). In the case of a disregarded entity, the person identified on line 1 must sign. Exempt payees, see *Exempt payee code*, earlier.

**Signature requirements.** Complete the certification as indicated in items 1 through 5 below.

**1. Interest, dividend, and barter exchange accounts opened before 1984 and broker accounts considered active during 1983.** You must give your correct TIN, but you do not have to sign the certification.

**2. Interest, dividend, broker, and barter exchange accounts opened after 1983 and broker accounts considered inactive during 1983.** You must sign the certification or backup withholding will apply. If you are subject to backup withholding and you are merely providing your correct TIN to the requester, you must cross out item 2 in the certification before signing the form.

**3. Real estate transactions.** You must sign the certification. You may cross out item 2 of the certification.

**4. Other payments.** You must give your correct TIN, but you do not have to sign the certification unless you have been notified that you have previously given an incorrect TIN. "Other payments" include payments made in the course of the requester's trade or business for rents, royalties, goods (other than bills for merchandise), medical and health care services (including payments to corporations), payments to a nonemployee for services, payments made in settlement of payment card and third party network transactions, payments to certain fishing boat crew members and fishermen, and gross proceeds paid to attorneys (including payments to corporations).

**5. Mortgage interest paid by you, acquisition or abandonment of secured property, cancellation of debt, qualified tuition program payments (under section 529), ABLE accounts (under section 529A), IRA, Coverdell ESA, Archer MSA or HSA contributions or distributions, and pension distributions.** You must give your correct TIN, but you do not have to sign the certification.

### What Name and Number To Give the Requester

For this type of account:	Give name and SSN of:
1. Individual	The individual
2. Two or more individuals (joint account) other than an account maintained by an FFI	The actual owner of the account or, if combined funds, the first individual on the account <sup>1</sup>
3. Two or more U.S. persons (joint account maintained by an FFI)	Each holder of the account
4. Custodial account of a minor (Uniform Gift to Minors Act)	The minor <sup>2</sup>
5. a. The usual revocable savings trust (grantor is also trustee)	The grantor-trustee <sup>1</sup>
b. So-called trust account that is not a legal or valid trust under state law	The actual owner <sup>1</sup>
6. Sole proprietorship or disregarded entity owned by an individual	The owner <sup>3</sup>
7. Grantor trust filing under Optional Form 1099 Filing Method 1 (see Regulations section 1.671-4(b)(2)(i)(A))	The grantor <sup>4</sup>
For this type of account:	Give name and EIN of:
8. Disregarded entity not owned by an individual	The owner
9. A valid trust, estate, or pension trust	Legal entity <sup>4</sup>
10. Corporation or LLC electing corporate status on Form 8832 or Form 2553	The corporation
11. Association, club, religious, charitable, educational, or other tax-exempt organization	The organization
12. Partnership or multi-member LLC	The partnership
13. A broker or registered nominee	The broker or nominee

For this type of account:	Give name and EIN of:
14. Account with the Department of Agriculture in the name of a public entity (such as a state or local government, school district, or prison) that receives agricultural program payments	The public entity
15. Grantor trust filing under the Form 1041 Filing Method or the Optional Form 1099 Filing Method 2 (see Regulations section 1.671-4(b)(2)(i)(B))	The trust

<sup>1</sup> List first and circle the name of the person whose number you furnish. If only one person on a joint account has an SSN, that person's number must be furnished.

<sup>2</sup> Circle the minor's name and furnish the minor's SSN.

<sup>3</sup> You must show your individual name and you may also enter your business or DBA name on the "Business name/disregarded entity" name line. You may use either your SSN or EIN (if you have one), but the IRS encourages you to use your SSN.

<sup>4</sup> List first and circle the name of the trust, estate, or pension trust. (Do not furnish the TIN of the personal representative or trustee unless the legal entity itself is not designated in the account title.) Also see *Special rules for partnerships*, earlier.

**\*Note:** The grantor also must provide a Form W-9 to trustee of trust.

**Note:** If no name is circled when more than one name is listed, the number will be considered to be that of the first name listed.

### Secure Your Tax Records From Identity Theft

Identity theft occurs when someone uses your personal information such as your name, SSN, or other identifying information, without your permission, to commit fraud or other crimes. An identity thief may use your SSN to get a job or may file a tax return using your SSN to receive a refund.

To reduce your risk:

- Protect your SSN,
- Ensure your employer is protecting your SSN, and
- Be careful when choosing a tax preparer.

If your tax records are affected by identity theft and you receive a notice from the IRS, respond right away to the name and phone number printed on the IRS notice or letter.

If your tax records are not currently affected by identity theft but you think you are at risk due to a lost or stolen purse or wallet, questionable credit card activity or credit report, contact the IRS Identity Theft Hotline at 1-800-908-4490 or submit Form 14039.

For more information, see Pub. 5027, Identity Theft Information for Taxpayers.

Victims of identity theft who are experiencing economic harm or a systemic problem, or are seeking help in resolving tax problems that have not been resolved through normal channels, may be eligible for Taxpayer Advocate Service (TAS) assistance. You can reach TAS by calling the TAS toll-free case intake line at 1-877-777-4778 or TTY/TDD 1-800-829-4059.

**Protect yourself from suspicious emails or phishing schemes.** Phishing is the creation and use of email and websites designed to mimic legitimate business emails and websites. The most common act is sending an email to a user falsely claiming to be an established legitimate enterprise in an attempt to scam the user into surrendering private information that will be used for identity theft.

The IRS does not initiate contacts with taxpayers via emails. Also, the IRS does not request personal detailed information through email or ask taxpayers for the PIN numbers, passwords, or similar secret access information for their credit card, bank, or other financial accounts.

If you receive an unsolicited email claiming to be from the IRS, forward this message to [phishing@irs.gov](mailto:phishing@irs.gov). You may also report misuse of the IRS name, logo, or other IRS property to the Treasury Inspector General for Tax Administration (TIGTA) at 1-800-366-4484. You can forward suspicious emails to the Federal Trade Commission at [spam@uce.gov](mailto:spam@uce.gov) or report them at [www.ftc.gov/complaint](http://www.ftc.gov/complaint). You can contact the FTC at [www.ftc.gov/idtheft](http://www.ftc.gov/idtheft) or 877-IDTHEFT (877-438-4338). If you have been the victim of identity theft, see [www.IdentityTheft.gov](http://www.IdentityTheft.gov) and Pub. 5027.

Visit [www.irs.gov/IdentityTheft](http://www.irs.gov/IdentityTheft) to learn more about identity theft and how to reduce your risk.

## Privacy Act Notice

Section 6109 of the Internal Revenue Code requires you to provide your correct TIN to persons (including federal agencies) who are required to file information returns with the IRS to report interest, dividends, or certain other income paid to you; mortgage interest you paid; the acquisition or abandonment of secured property; the cancellation of debt; or contributions you made to an IRA, Archer MSA, or HSA. The person collecting this form uses the information on the form to file information returns with the IRS, reporting the above information. Routine uses of this information include giving it to the Department of Justice for civil and criminal litigation and to cities, states, the District of Columbia, and U.S. commonwealths and possessions for use in administering their laws. The information also may be disclosed to other countries under a treaty, to federal and state agencies to enforce civil and criminal laws, or to federal law enforcement and intelligence agencies to combat terrorism. You must provide your TIN whether or not you are required to file a tax return. Under section 3406, payers must generally withhold a percentage of taxable interest, dividend, and certain other payments to a payee who does not give a TIN to the payer. Certain penalties may also apply for providing false or fraudulent information.

# Exhibit "F"

## Certification Regarding Debarment

**Certification  
Regarding Debarment, Suspension Ineligibility**

As is required by the Federal Regulations Implementing Executive Order 12549, Debarment and Suspension, 45 CFR Part 76, Government-wide Debarment and Suspension, in the applicant certifies, to the best of his or her knowledge and belief, that both it and its principals:

a. Are not presently debarred, suspended, proposed for debarment, declared ineligible, or voluntarily excluded from participation in this transaction by any federal department or agency;

b. Have not within a three-year period preceding this bid/proposal and/or application been convicted of or had a civil judgment rendered against them for commission of fraud or a criminal offense in connection with obtaining, attempting to obtain, or performing a public (federal, state or local) transaction or contract under a public transaction, violation of federal or state antitrust statutes or commission of embezzlement, theft, theory, forgery, bribery, falsification or destruction of records, making false statements, or receiving stolen property;

c. Are not presently indicted for or otherwise criminally or civilly charged by a government entity with commission of any of the offenses enumerated herein; and

d. Have not within a three-year period preceding this bid/proposal and/or application had one or more public transactions terminated of cause or default.

Signature: \_\_\_\_\_

Print Name: \_\_\_\_\_

Title: \_\_\_\_\_

Telephone Number: \_\_\_\_\_

Date: \_\_\_\_\_

If the proposer is unable to certify to all of the statements in this Certification, such proposer should attach an explanation to this proposal.

Exhibit "G"

Title VI Appendices

"A" thru "E"

## APPENDIX A

During the performance of this contract, the contractor, for itself, its assignees, and successors in interest (hereinafter referred to as the "contractor") agrees as follows:

1. **Compliance with Regulations:** The contractor (hereinafter includes consultants) will comply with the Acts and the Regulations relative to Nondiscrimination in Federally-assisted programs of the U.S. Department of Transportation, the Federal Highway Administration, as they may be amended from time to time, which are herein incorporated by reference and made a part of this contract.
2. **Nondiscrimination:** The contractor, with regard to the work performed by it during the contract, will not discriminate on the grounds of race, color, or national origin in the selection and retention of subcontractors, including procurements of materials and leases of equipment. The contractor will not participate directly or indirectly in the discrimination prohibited by the Acts and the Regulations, including employment practices when the contract covers any activity, project, or program set forth in Appendix B of 49 CFR Part 21.
3. **Solicitations for Subcontracts, Including Procurements of Materials and Equipment:** In all solicitations, either by competitive bidding, or negotiation made by the contractor for work to be performed under a subcontract, including procurements of materials, or leases of equipment, each potential subcontractor or supplier will be notified by the contractor of the contractor's obligations under this contract and the Acts and the Regulations relative to Nondiscrimination on the grounds of race, color, or national origin.
4. **Information and Reports:** The contractor will provide all information and reports required by the Acts, the Regulations, and directives issued pursuant thereto and will permit access to its books, records, accounts, other sources of information, and its facilities as may be determined by the Recipient or the Federal Highway Administration to be pertinent to ascertain compliance with such Acts, Regulations, and instructions. Where any information required of a contractor is in the exclusive possession of another who fails or refuses to furnish the information, the contractor will so certify to the Recipient or the Federal Highway Administration, as appropriate, and will set forth what efforts it has made to obtain the information.
5. **Sanctions for Noncompliance:** In the event of a contractor's noncompliance with the Nondiscrimination provisions of this contract, the Recipient will impose such contract sanctions as it or the Federal Highway Administration may determine to be appropriate, including, but not limited to:
  - a. withholding payments to the contractor under the contract until the contractor complies; and/or
  - b. cancelling, terminating, or suspending contract, in whole or in part.
6. **Incorporation of Provisions:** The contractor will include the provisions of paragraphs one through six in every subcontract, including procurements of materials and leases of equipment, unless exempt by the Acts, the Regulations and directives issued pursuant thereto. The contractor will take action with respect to any subcontract or procurement as the Recipient or the Federal Highway Administration may direct as a means of enforcing such provisions including sanctions for noncompliance. Provided, that if the contractor becomes involved in, or is threatened with litigation by a subcontractor, or supplier because of such direction, the contractor may request the Recipient to enter into any litigation to protect the interests of the Recipient. In addition, the contractor may request the United States to enter into the litigation to protect the interests of the United States.

## APPENDIX B

### CLAUSES FOR DEEDS TRANSFERRING UNITED STATES PROPERTY

The following clauses will be included in deeds effecting or recording the transfer of real property, structures, or improvements thereon, or granting interest therein from the United States pursuant to the provisions of Assurance 4:

NOW, THEREFORE, the U.S. Department of Transportation as authorized by law and upon the condition that the **COUNTY OF HIDALGO** will accept title to the lands and maintain the project constructed thereon in accordance with all applicable federal statutes, the Regulations for the Administration of all Department of Transportation programs, and the policies and procedures prescribed by the Federal Highway Administration of the U.S. Department of Transportation in accordance and in compliance with all requirements imposed by Title 49, Code of Federal Regulations, U.S. Department of Transportation, Subtitle A, Office of the Secretary, Part 21, Nondiscrimination in Federally-assisted programs of the U.S. Department of Transportation pertaining to and effectuating the provisions of Title VI of the Civil Rights Act of 1964 (78 Stat. 252; 42 U.S.C. § 2000d to 2000d-4), does hereby remise, release, quitclaim and convey unto the **COUNTY OF HIDALGO** all the right, title and interest of the U.S. Department of Transportation in and to said lands described in Exhibit 1 attached hereto and made a part hereof.

#### (HABENDUM CLAUSE)

TO HAVE AND TO HOLD said lands and interests therein unto **COUNTY OF HIDALGO** and its successors forever, subject, however, to the covenants, conditions, restrictions and reservations herein contained as follows, which will remain in effect for the period during which the real property or structures are used for a purpose for which Federal financial assistance is extended or for another purpose involving the provision of similar services or benefits and will be binding on the **COUNTY OF HIDALGO**, its successors and assigns.

The **COUNTY OF HIDALGO**, in consideration of the conveyance of said lands and interests in lands, does hereby covenant and agree as a covenant running with the land for itself, its successors and assigns, that (1) no person will on the grounds of race, color, or national origin, be excluded from participation in, be denied the benefits of, or be otherwise subjected to discrimination with regard to any facility located wholly or in part on, over, or under such lands hereby conveyed [,] [and]\* (2) that the **COUNTY OF HIDALGO** will use the lands and interests in lands and interests in lands so conveyed, in compliance with all requirements imposed by or pursuant to Title 49, Code of Federal Regulations, U.S. Department of Transportation, Subtitle A, Office of the Secretary, Part 21, Nondiscrimination in Federally-assisted programs of the U.S. Department of Transportation, Effectuation of Title VI of the Civil Rights Act of 1964, and as said Regulations and Acts may be amended[, and(3) that in the event of breach of any of the above-mentioned nondiscrimination conditions, the Department will have a right to enter or re-enter said lands and facilities on said land, and that above described land and facilities will thereon revert to and vest in and become the absolute property of the U.S. Department of Transportation and its assigns as such interest existed prior to this instruction].\*

(\*Reverted clause and related language to be used only when it is determined that such a clause is necessary in order to make clear the purpose of Title VI.)

## APPENDIX C

### CLAUSES FOR TRANSFER OF REAL PROPERTY ACQUIRED OR IMPROVED UNDER THE ACTIVITY, FACILITY, OR PROGRAM

The following clauses will be included in deeds, licenses, leases, permits, or similar instruments entered into by the **COUNTY OF HIDALGO** pursuant to the provisions of Assurance 7(a):

- A. The (grantee, lessee, permittee, etc. as appropriate) for himself/herself, his/her heirs, personal representatives, successors in interest, and assigns, as a part of the consideration hereof, does hereby covenant and agree [in the case of deeds and leases add "as a covenant running with the land"] that:
1. In the event facilities are constructed, maintained, or otherwise operated on the property described in this (deed, license, lease, permit, etc.) for a purpose for which a U.S. Department of Transportation activity, facility, or program is extended or for another purpose involving the provision of similar services or benefits, the (grantee, licensee, lessee, permitted, etc.) will maintain and operate such facilities and services in compliance with all requirements imposed by the Acts and Regulations (as may be amended) such that no person on the grounds of race, color, or national origin, will be excluded from participation in, denied the benefits of, or be otherwise subjected to discrimination in the use of said facilities.
- B. With respect to licenses, leases, permits, etc., in the event of breach of any of the above Nondiscrimination covenants, **COUNTY OF HIDALGO** will have the right to terminate the (lease, license, permit, etc.) and to enter, re-enter, and repossess said lands and facilities thereon, and hold the same as if the (lease, license, permit, etc.) had never been made or issued.\*
- C. With respect to a deed, in the event of breach of any of the above Nondiscrimination covenants, the **COUNTY OF HIDALGO** will have the right to enter or re-enter the lands and facilities thereon, and the above described lands and facilities will there upon revert to and vest in and become the absolute property of the **COUNTY OF HIDALGO** and its assigns.\*

(\*Reverted clause and related language to be used only when it is determined that such a clause is necessary in order to make clear the purpose of Title VI.)

## APPENDIX D

### CLAUSES FOR CONSTRUCTION/USE/ACCESS TO REAL PROPERTY ACQUIRED UNDER THE ACTIVITY, FACILITY OR PROGRAM

The following clauses will be included in deeds, licenses, permits, or similar instruments/agreements entered into by **COUNTY OF HIDALGO** pursuant to the provisions of Assurance 7(b):

- A. The (grantee, licensee, permittee, etc., as appropriate) for himself/herself, his/her heirs, personal representatives, successors in interest, and assigns, as a part of the consideration hereof, does hereby covenant and agree (in the case of deeds and leases add, "as a covenant running with the land") that (1) no person on the ground of race, color, or national origin, will be excluded from participation in, denied the benefits of, or be otherwise subjected to discrimination in the use of said facilities, (2) that in the construction of any improvements on, over, or under such land, and the furnishing of services thereon, no person on the ground of race, color, or national origin, will be excluded from participation in, denied the benefits of, or otherwise be subjected to discrimination, (3) that the (grantee, licensee, lessee, permittee, etc.) will use the premises in compliance with all other requirements imposed by or pursuant to the Acts and Regulations, as amended, set forth in this Assurance.
- B. With respect to (licenses, leases, permits, etc.), in the event of breach of any of the above Nondiscrimination covenants, **COUNTY OF HIDALGO** will have the right to terminate the (license, permit, etc., as appropriate) and to enter or re-enter and repossess said land and the facilities thereon, and hold the same as if said (license, permit, etc., as appropriate) had never been made or issued.\*
- C. With respect to deeds, in the event of breach of any of the above Nondiscrimination covenants, **COUNTY OF HIDALGO** will there upon revert to and vest in and become the absolute property of **COUNTY OF HIDALGO** and its assigns.\*

(\*Reverted clause and related language to be used only when it is determined that such a clause is necessary in order to make clear the purpose of Title VI.)

## APPENDIX E

During the performance of this contract, the contractor, for itself, its assignees, and successors in interest (hereinafter referred to as the "contractor") agrees to comply with the following nondiscrimination statutes and authorities; including but not limited to:

### Pertinent Nondiscrimination Authorities:

- Title VI of the Civil Rights Act of 1964 (42 U.S.C. § 2000d et seq., 78 stat. 252), (prohibits discrimination on the basis of race, color, national origin); and 49CFR Part 21.
- The Uniform Relocation Assistance and Real Property Acquisition Policies Act of 1970, (42U.S.C. § 4601), (prohibits unfair treatment of persons displaced or whose property has been acquired because of Federal or Federal-aid programs and projects);
- Federal-Aid Highway Act of 1973, (23U.S.C. § 324et seq.), (prohibits discrimination on the basis of sex);
- Section 504 of the Rehabilitation Act of 1973, (29U.S.C. § 794 et seq.), as amended, (prohibits discrimination on the basis of disability); and 49CFR Part 27;
- The Age Discrimination Act of 1975, as amended, (42U.S.C. § 6101 et seq.), (prohibits discrimination on the basis of age);
- Airport and Airway Improvement Act of 1982, (49U.S.C. § 4 71, Section 4 7123), as amended, (prohibits discrimination based on race, creed, color, national origin, or sex);
- The Civil Rights Restoration Act of 1987, (PL 100-209), (Broadened the scope, coverage and applicability of Title VI of the Civil Rights Act of 1964, The Age Discrimination Act of 1975 and Section 504 of the Rehabilitation Act of 1973, by expanding the definition of the terms "programs or activities" to include all of the programs or activities of the Federal-aid recipients, sub recipients and contractors, whether such programs or activities are Federally funded or not);
- Titles II and III of the Americans with Disabilities Act, which prohibit discrimination on the basis of disability in the operation of public entities, public and private transportation systems, places of public accommodation, and certain testing entities (42 U.S.C. §§ 12131-12189) as implemented by Department of Transportation regulations at 49C.F.R. parts 37 and 38;
- The Federal Aviation Administration's Nondiscrimination statute (49U.S.C. § 47123) (prohibits discrimination on the basis of race, color, national origin, and sex);
- Executive Order 12898, Federal Actions to Address Environmental Justice in Minority Populations and Low-Income Populations, which ensures discrimination against minority populations by discouraging programs, policies, and activities with disproportionately high and adverse human health or environmental effects on minority and low-income populations;
- Executive Order 13166, Improving Access to Services for Persons with Limited English Proficiency, and resulting agency guidance, national origin discrimination includes discrimination because of limited English proficiency (LEP). To ensure compliance with Title VI, you must take reasonable steps to ensure that LEP persons have meaningful access to your programs (70 Fed. Reg. at 74087 to 74100);
- Title IX of the Education Amendments of 1972, as amended, which prohibits you from discriminating because of sex in education programs or activities (20 U .S.C. 1681 et seq).

# **EXHIBIT “H”**

**(IF APPLICABLE)**

**2 C.F.R. § 200.326 & 2 C.F.R. Part 200, Appendix II,  
Required Contract Clauses for Non-Federal Entity  
Contracts Under Federal Awards**

**&**

**Required Contract Clauses for Non-Federal Entity  
Contracts Under Federal Awards with the Federal  
Emergency Management Agency (FEMA)**

## **2 C.F.R. § 200.326 & 2 C.F.R. Part 200, Appendix II, Required Contract Clauses for Non-Federal Entity Contracts Under Federal Awards**

The United States Office of Management and Budget (OMB) issued in 2 C.F.R. 200: *Uniform Administrative Requirements, Cost Principles and Audit Requirements for Federal Awards* (Uniform Guidance). Subpart D: Post Federal Award Requirements: 2 CFR §§200.317-200.326 of the Uniform Guidance contain provisions applicable to procurements made with federal grant funding.

As a non-Federal entity, the County of Hidalgo's ("County") contracts must contain the applicable contract clauses described in Appendix II to the Uniform Guidance (Contract Provisions for non-Federal Entity Contracts Under Federal Awards), which are set forth below. 2 C.F.R. §200.326. If applicable, the following clauses shall supersede any existing, similar clauses stated within the bid document, contract, and/or Terms and Conditions. *The term "Contractor" used herein refers to the proposer, bidder or other entity/individual responding to the applicable procurement packet.*

*If applicable, the regulations in 2 CFR, Part 200 and Appendix II to the Uniform Guidance, as it may be amended from time to time, and the contract clauses below, are incorporated by reference as part of this procurement packet and any resulting agreement.*

To procure goods and services using funds under a federal grant or contract, specific federal laws, regulations, and requirements may apply in addition to those under state law. The following provisions are required and apply when federal funds are expended by the County of Hidalgo for any contract resulting from this procurement process.

### **1. Remedies.**

- a. **Applicability.** This requirement applies to all Federal grant and cooperative agreement programs.
- b. **Standard.** Contracts for more than the simplified acquisition threshold currently set at \$150,000, which is the inflation adjusted amount determined by the Civilian Agency Acquisition Council and the Defense Acquisition Regulations Council (Councils) as authorized by 41 U.S.C. 1908, must address administrative, contractual, or legal remedies in instances where contractors violate or breach contract terms, and provide for such sanctions and penalties as appropriate. See 2 C.F.R. Part 200, Appendix II, ¶ A.
- c. **Statement.** Pursuant to Federal Rule (A) above, when federal funds are expended by the County, the County reserves all rights and privileges under the applicable laws and regulations with respect to this procurement in the event of breach of contract by either party. Contractor shall comply with all applicable Federal, State of Texas, and local laws, rules, and regulations and shall obtain all applicable licenses and permits for the conduct of its business and the performance of the services, and any provision of equipment and material ("Applicable Law"). All transactions related to any of the Contract Documents shall be governed by the laws of the State of Texas, and trial of any action brought in connection with the bid or the Contract Documents shall be held exclusively in a state court in the County of Hidalgo, Texas.

## 2. Termination for Cause and Convenience.

- a. Applicability. This requirement applies to all Federal grant and cooperative agreement programs.
- b. Standard. All contracts in excess of \$10,000 shall address termination for cause and for convenience by the non-Federal entity including the manner by which it will be effected and the basis for settlement as follows. See 2 C.F.R. Part 200, Appendix II, ¶ B.
- c. Statement. Termination. County may terminate this Agreement for any reason upon ten (10) days written notice to the other party. County may terminate this Agreement immediately upon written notice if Contractor breaches this Agreement. In the event of any termination, Contractor shall promptly deliver to the County any and all Work Materials prepared for the County prior to the effective date of such termination, all of which shall become County's sole property. After receipt of the Work Materials, County will pay Contractor for the services which the County determines were satisfactorily performed as of the effective date of the termination.

*Excuses for Non-Performance.* Either party shall be absolved from its obligations under this contract when and to the extent that performance is delayed or prevented (and in the County of Hidalgo's case when and to the extent that its need for the articles, materials or work to be supplied hereunder is reduced or eliminated) by reason of acts of God, fire explosion, war riots, strikes, labor disputes, or governmental laws, orders or regulations.

*Default.* If Contractor or Subcontractor shall breach any provision hereof or shall become insolvent, enter voluntary or involuntary bankruptcy or receivership proceedings or make an assignment to the benefit of creditors, County of Hidalgo shall have the right (without limiting any other rights or remedies which it may have hereunder or by operation of law) to terminate this contract by written notice to Contractor whereupon County shall be relieved of all further obligation hereunder except the obligation to pay the reasonable value of Contractor's prior performance (at not exceeding the contract rate), and Contractor shall be liable to County for all costs incurred by County in completing or procuring the completion of performance in excess of the contract price herein specified. The County's right to require strict performance of any obligation hereunder shall not be affected by any previous waiver, forbearance of course of dealing. Time is of the essence thereof.

## 3. Equal Employment Opportunity.

- a. Applicability: This requirement applies to all Federal grant and cooperative agreement programs.
- b. Standard. Except as otherwise provided under 41 C.F.R. Part 60, all contracts that meet the definition of "federally assisted construction contract" in 41 C.F.R. § 60-1.3 must include the equal opportunity clause provided under 41 C.F.R. § 60- 1.4(b), in accordance with Executive Order 11246, *Equal Employment Opportunity* (30 Fed. Reg. 12319, 12935, 3 C.F.R. Part, 1964-1965 Comp., p. 339), as amended by Executive Order 11375, *Amending Executive Order 11246 Relating to Equal Employment Opportunity*, and implementing regulations at 41 C.F.R. Part 60 (Office of Federal Contract Compliance Programs, Equal Employment Opportunity, Department of Labor). See 2 C.F.R. Part 200, Appendix II, ¶ C.

c. Key Definitions:

- (1) *Federally Assisted Construction Contract.* The regulation at 41 C.F.R. § 60-1.3 defines a "federally assisted construction contract" as any agreement or modification thereof between any applicant and a person for construction work which is paid for in whole or in part with funds obtained from the Government or borrowed on the credit of the Government pursuant to any Federal program involving a grant, contract, loan, insurance, or guarantee, or undertaken pursuant to any Federal program involving such grant, contract, loan, insurance, or guarantee, or any application or modification thereof approved by the Government for a grant, contract, loan, insurance, or guarantee under which the applicant itself participates in the construction work.
- (2) *Construction Work.* The regulation at 41 C.F.R. § 60-1.3 defines "construction work" as the construction, rehabilitation, alteration, conversion, extension, demolition or repair of buildings, highways, or other changes or improvements to real property, including facilities providing utility services. The term also includes the supervision, inspection, and other onsite functions incidental to the actual construction

- d. Statement: Contractor will comply with the Nondiscrimination Civil Rights Act of 1964, as amended and all Federal regulations relative to nondiscrimination in Federally assisted programs. The regulation at 41 C.F.R. Part 60-1.4(b) requires the insertion of the following contract clause:

"During the performance of this contract, the contractor agrees as follows:

- (1) The contractor will not discriminate against any employee or applicant for employment because of race, color, religion, sex, or national origin. The contractor will take affirmative action to ensure that applicants are employed, and that employees are treated during employment without regard to their race, color, religion, sex, or national origin. Such action shall include, but not be limited to the following: Employment, upgrading, demotion, or transfer; recruitment or recruitment advertising; layoff or termination; rates of pay or other forms of compensation; and selection for training, including apprenticeship. The contractor agrees to post in conspicuous places, available to employees and applicants for employment, notices to be provided setting forth the provisions of this nondiscrimination clause.
- (2) The contractor will, in all solicitations or advertisements for employees placed by or on behalf of the contractor, state that all qualified applicants will receive considerations for employment without regard to race, color, religion, sex, or national origin.
- (3) The contractor will send to each labor union or representative of workers with which he has a collective bargaining agreement or other contract or understanding, a notice to be provided advising the said labor union or workers' representatives of the contractor's commitments under this section, and shall post copies of the notice in conspicuous places available to employees and applicants for employment.
- (4) The contractor will comply with all provisions of Executive Order 11246 of September 24, 1965, and of the rules, regulations, and relevant orders of the Secretary of Labor.
- (5) The contractor will furnish all information and reports required by Executive Order 11246 of September 24, 1965, and by rules, regulations, and orders of the Secretary of Labor, or pursuant thereto, and will permit access to his books, records, and accounts by the

administering agency and the Secretary of Labor for purposes of investigation to ascertain compliance with such rules, regulations, and orders.

(6) In the event of the contractor's noncompliance with the nondiscrimination clauses of this contract or with any of the said rules, regulations, or orders, this contract may be canceled, terminated, or suspended in whole or in part and the contractor may be declared ineligible for further Government contracts or federally assisted construction contracts in accordance with procedures authorized in Executive Order 11246 of September 24, 1965, and such other sanctions as may be imposed and remedies invoked as provided in Executive Order 11246 of September 24, 1965, or by rule, regulation, or order of the Secretary of Labor, or as otherwise provided by law.

(7) The contractor will include the portion of the sentence immediately preceding paragraph (1) and the provisions of paragraphs (1) through (7) in every subcontract or purchase order unless exempted by rules, regulations, or orders of the Secretary of Labor issued pursuant to section 204 of Executive Order 11246 of September 24, 1965, so that such provisions will be binding upon each subcontractor or vendor. The contractor will take such action with respect to any subcontract or purchase order as the administering agency may direct as a means of enforcing such provisions, including sanctions for noncompliance: Provided, however, That in the event a contractor becomes involved in, or is threatened with, litigation with a subcontractor or vendor as a result of such direction by the administering agency the contractor may request the United States to enter into such litigation to protect the interests of the United States."

#### 4. Davis Bacon Act and Copeland Anti-Kickback Act.

- a. Applicability of Davis-Bacon Act. The Davis-Bacon Act only applies to the emergency Management Preparedness Grant Program, Homeland Security Grant Program, Nonprofit Security Grant Program, Tribal Homeland Security Grant Program, Port Security Grant Program, and Transit Security Grant Program. **It does not apply to other Federal grant and cooperative agreement programs, including the Public Assistance Program.**
- b. Standard. All prime construction contracts in excess of \$2,000 awarded by non-Federal entities must include a provision for compliance with the Davis-Bacon Act (40 U.S.C. §§ 3141-3144 and 3146-3148) as supplemented by Department of Labor regulations at 29 C.F.R. Part 5 (Labor Standards Provisions Applicable to Contracts Covering Federally Financed and Assisted Construction)). See 2 C.F.R. Part 200, Appendix II, ¶ D.

In accordance with the statute, contractors must be required to pay wages to laborers and mechanics at a rate not less than the prevailing wages specified in a wage determination made by the Secretary of Labor. In addition, contractors must be required to pay wages not less than once a week.

The non-Federal entity must place a copy of the current prevailing wage determination issued by the Department of Labor in each solicitation. The decision to award a contract or subcontract must be conditioned upon the acceptance of the wage determination. The non-Federal entity must report all suspected or reported violations to the Federal awarding City.

In contracts subject to the Davis-Bacon Act, the contracts must also include a provision for compliance with the Copeland "Anti-Kickback" Act (40 U.S.C. § 3145), as supplemented by

Department of Labor regulations at 29 C.F.R. Part 3 (Contractors and Subcontractors on Public Building or Public Work Financed in Whole or in Part by Loans or Grants from the United States). The Copeland Anti-Kickback Act provides that each contractor or subrecipient must be prohibited from inducing, by any means, any person employed in the construction, completion, or repair of public work, to give up any part of the compensation to which he or she is otherwise entitled. The non-Federal entity must report all suspected or reported violations to FEMA or applicable Federal entity.

- c. Statement. The regulation at 29 C.F.R. § 5.5(a) does provide the required contract clause that applies to compliance with both the Davis-Bacon and Copeland Acts. However, as discussed in the previous subsection, the Davis-Bacon Act does not apply to Public Assistance recipients and subrecipients. In situations where the Davis-Bacon Act does not apply, neither does the Copeland "Anti-Kickback Act." However, for purposes of grant programs where both clauses do apply, FEMA or applicable Federal entity requires the following contract clause:

"Compliance with the Copeland "Anti-Kickback" Act.

(1) *Contractor.* The contractor shall comply with 18 U.S.C. § 874, 40 U.S.C. § 3145, and the requirements of 29 C.F.R. pt. 3 as may be applicable, which are incorporated by reference into this contract.

(2) *Subcontracts.* The contractor or subcontractor shall insert in any subcontracts the clause above and such other clauses as Federal requirements may by appropriate instructions require, and also a clause requiring the subcontractors to include these clauses in any lower tier subcontracts. The prime contractor shall be responsible for the compliance by any subcontractor or lower tier subcontractor with all of these contract clauses.

(3) *Breach.* A breach of the contract clauses above may be grounds for termination of the contract, and for debarment as a contractor and subcontractor as provided in 29 C.F.R. § 5.12."

5. Contract Work Hours and Safety Standards Act.

- a. Applicability: This requirement applies to all Federal grant and cooperative agreement programs.
- b. Standard. Where applicable (see 40 U.S.C. § 3701), all contracts awarded by the non-Federal entity in excess of \$100,000 that involve the employment of mechanics or laborers must include a provision for compliance with 40 U.S.C. §§ 3702 and 3704, as supplemented by Department of Labor regulations at 29 C.F.R. Part 5. See 2 C.F.R. Part 200, Appendix II, ¶ E.

Under 40 U.S.C. § 3702, each contractor must be required to compute the wages of every mechanic and laborer on the basis of a standard work week of 40 hours. Work in excess of the standard work week is permissible provided that the worker is compensated at a rate of not less than one and a half times the basic rate of pay for all hours worked in excess of 40 hours in the work week.

The requirements of 40 U.S.C. § 3704 are applicable to construction work and provide that no laborer or mechanic must be required to work in surroundings or under working conditions which are unsanitary, hazardous or dangerous. These requirements do not apply to the purchases of

supplies or materials or articles ordinarily available on the open market, or contracts for transportation or transmission of intelligence.

The regulation at 29 C.F.R. § 5.5(b) provides the required contract clause concerning compliance with the Contract Work Hours and Safety Standards Act:

c. Statement.

“Compliance with the Contract Work Hours and Safety Standards Act.

(1) *Overtime requirements.* No contractor or subcontractor contracting for any part of the contract work which may require or involve the employment of laborers or mechanics shall require or permit any such laborer or mechanic in any workweek in which he or she is employed on such work to work in excess of forty hours in such workweek unless such laborer or mechanic receives compensation at a rate not less than one and one-half times the basic rate of pay for all hours worked in excess of forty hours in such workweek.

(2) *Violation; liability for unpaid wages; liquidated damages.* In the event of any violation of the clause set forth in paragraph (1) of this section the contractor and any subcontractor responsible therefor shall be liable for the unpaid wages. In addition, such contractor and subcontractor shall be liable to the United States (in the case of work done under contract for the District of Columbia or a territory, to such District or to such territory), for liquidated damages. Such liquidated damages shall be computed with respect to each individual laborer or mechanic, including watchmen and guards, employed in violation of the clause set forth in paragraph (1) of this section, in the sum of \$10 for each calendar day on which such individual was required or permitted to work in excess of the standard workweek of forty hours without payment of the overtime wages required by the clause set forth in paragraph (1) of this section.

(3) *Withholding for unpaid wages and liquidated damages.* The County of Hidalgo shall upon its own action or upon written request of an authorized representative of the Department of Labor withhold or cause to be withheld, from any moneys payable on account of work performed by the contractor or subcontractor under any such contract or any other Federal contract with the same prime contractor, or any other federally-assisted contract subject to the Contract Work Hours and Safety Standards Act, which is held by the same prime contractor, such sums as may be determined to be necessary to satisfy any liabilities of such contractor or subcontractor for unpaid wages and liquidated damages as provided in the clause set forth in paragraph (2) of this section.

(4) *Subcontracts.* The contractor or subcontractor shall insert in any subcontracts the clauses set forth in paragraph (1) through (4) of this section and also a clause requiring the subcontractors to include these clauses in any lower tier subcontracts. The prime contractor shall be responsible for compliance by any subcontractor or lower tier subcontractor with the clauses set forth in paragraphs (1) through (4) of this section.”

6. Rights to Inventions Made Under a Contract or Agreement.

- a. Applicability: Stafford Act Disaster Grants. This requirement **does not apply to the Public Assistance**, Hazard Mitigation Grant Program, Fire Management Assistance Grant Program, Crisis Counseling Assistance and Training Grant Program, Disaster Case Management Grant

Program, and Federal Assistance to Individuals and Households – Other Needs Assistance Grant Program, as FEMA or Federal awards under these programs do not meet the definition of “funding agreement.”

- b. Standard. If the FEMA or Federal award meets the definition of “funding agreement” under 37 C.F.R. § 401.2(a) and the non-Federal entity wishes to enter into a contract with a small business firm or nonprofit organization regarding the substitution of parties, assignment or performance of experimental, developmental, or research work under that “funding agreement,” the non-Federal entity must comply with the requirements of 37 C.F.R. Part 401 (Rights to Inventions Made by Nonprofit Organizations and Small Business Firms Under Government Grants, Contracts and Cooperative Agreements), and any implementing regulations issued by FEMA or applicable awarding agency. See 2 C.F.R. Part 200, Appendix II, ¶ F.
- c. Key Definition: The regulation at 37 C.F.R. § 401.2(a) currently defines “funding agreement” as any contract, grant, or cooperative agreement entered into between any Federal agency, other than the Tennessee Valley Authority, and any contractor for the performance of experimental, developmental, or research work funded in whole or in part by the Federal government. This term also includes any assignment, substitution of parties, or subcontract of any type entered into for the performance of experimental, developmental, or research work under a funding agreement as defined in the first sentence of this paragraph.

7. Clean Air Act and the Federal Water Pollution Control Act.

- a. Applicability and Standard: Contracts of amounts in excess of \$150,000 must contain a provision that requires the contractor to agree to comply with all applicable standards, orders, or regulations issued pursuant to the Clean Air Act (42 U.S.C. §§ 7401-7671q) and the Federal Water Pollution Control Act as amended (33 U.S.C. §§ 1251-1387). Violations must be reported to the Federal awarding agency and the Regional Office of the Environmental Protection Agency. See 2 C.F.R. Part 200, Appendix II, ¶ G.
- b. Statement: Included in contracts as provided in section “7a” above.
  - (1) The contractor agrees to comply with all applicable standards, orders or regulations issued pursuant to the Clean Air Act, as amended, 42 U.S.C. § 7401 et seq. and the Federal Water Pollution Control Act, as amended, 33 U.S.C. 1251 et seq.
  - (2) The contractor agrees to report each violation to the Federal awarding agency (e.g. Federal Emergency Management Agency-FEMA) and the Regional Office of the Environmental Protection Agency. Contractor understands and agrees that each violation reported to the County of Hidalgo will, in turn, be reported as required to assure notification to the Federal awarding agency and the appropriate Environmental Protection Agency Regional Office.
  - (3) The contractor agrees to include these requirements in each subcontract exceeding \$150,000 financed in whole or in part with Federal assistance provided by the applicable Federal awarding agency (e.g. FEMA).

8. Debarment and Suspension.

- a. Applicability: This requirement applies to all Federal grant and cooperative agreement programs.

- b. Standard. Non-Federal entities and contractors are subject to the debarment and suspension regulations implementing Executive Order 12549, *Debarment and Suspension* (1986) and Executive Order 12689, *Debarment and Suspension* (1989) at 2 C.F.R. Part 180 and the Department of Homeland Security's regulations at 2 C.F.R. Part 3000 (Nonprocurement Debarment and Suspension).

These regulations restrict awards, subawards, and contracts with certain parties that are debarred, suspended, or otherwise excluded from or ineligible for participation in Federal assistance programs and activities. See 2 C.F.R. Part 200, Appendix II, ¶ H; and Chapter IV, ¶ 6.d and Appendix C, ¶ 2. A contract award must not be made to parties listed in the SAM Exclusions. SAM Exclusions is the list maintained by the General Services Administration that contains the names of parties debarred, suspended, or otherwise excluded by agencies, as well as parties declared ineligible under statutory or regulatory authority other than Executive Order 12549. SAM exclusions can be accessed at [www.sam.gov](http://www.sam.gov). See 2 C.F.R. § 180.530; Chapter IV, ¶ 6.d and Appendix C, ¶ 2.

In general, an "excluded" party cannot receive a Federal grant award or a contract within the meaning of a "covered transaction," to include subawards and subcontracts. This includes parties that receive Federal funding indirectly, such as contractors to recipients and subrecipients. The key to the exclusion is whether there is a "covered transaction," which is any nonprocurement transaction (unless excepted) at either a "primary" or "secondary" tier. Although "covered transactions" do not include contracts awarded by the Federal Government for purposes of the nonprocurement common rule and DHS's implementing regulations, it does include some contracts awarded by recipients and subrecipient.

Specifically, a covered transaction includes the following contracts for goods or services:

- (1) The contract is awarded by a recipient or subrecipient in the amount of at least \$25,000.
- (2) The contract requires the approval of FEMA or applicable Federal entity, regardless of amount.
- (3) The contract is for Federally-required audit services.
- (4) A subcontract is also a covered transaction if it is awarded by the contractor of a recipient or subrecipient and requires either the approval of FEMA or applicable Federal entity or is in excess of \$25,000.

- c. Statement. The following provides a debarment and suspension clause. It incorporates a method of verifying that contractors are not excluded or disqualified:

For maximum protection, provide a print or electronic document for every prime and subcontractor, from [www.sam.gov](http://www.sam.gov) in order to ensure that they are not debarred, suspended, or otherwise excluded from or ineligible for participation in Federal assistance programs and activities.

This contract is a covered transaction for purposes of 2 C.F.R. pt. 180 and 2 C.F.R. pt. 3000. As such the contractor is required to verify that none of the contractor, its principals (defined at 2 C.F.R. § 180.995), or its affiliates (defined at 2 C.F.R. § 180.905) are excluded (defined at 2 C.F.R. 180.940) or disqualified (defined at 2 C.F.R. § 180.935).

The contractor must comply with 2 C.F.R. pt. 180, subpart C and 2 C.F.R. pt. 3000, subpart C and must include a requirement to comply with these regulations in any lower tier covered transaction it enters into.

This certification is a material representation of fact relied upon by (insert name of subrecipient). If it is later determined that the contractor did not comply with 2 C.F.R. pt. 180, subpart C and 2 C.F.R. pt. 3000, subpart C, in addition to remedies available to (name of state agency serving as recipient and name of subrecipient), the Federal Government may pursue available remedies, including but not limited to suspension and/or debarment.

The bidder or proposer agrees to comply with the requirements of 2 C.F.R. pt. 180, subpart C and 2 C.F.R. pt. 3000, subpart C while this offer is valid and throughout the period of any contract that may arise from this offer. The bidder or proposer further agrees to include a provision requiring such compliance in its lower tier covered transactions.”

9. **Byrd Anti-Lobbying Amendment.**

- a. **Applicability:** This requirement applies to all Federal grant and cooperative agreement programs.
- b. **Standard.** Contractors that apply or bid for an award of \$100,000 or more must file the required certification. See 2 C.F.R. Part 200, Appendix II, ¶ I; 44 C.F.R. Part 18; Chapter IV, 6.c; Appendix C, ¶ 4. Each tier certifies to the tier above that it will not and has not used Federal appropriated funds to pay any person or organization for influencing or attempting to influence an officer or employee of any City, a member of Congress, officer or employee of Congress, or an employee of a member of Congress in connection with obtaining any Federal contract, grant or any other award covered by 31 U.S.C. § 1352. Each tier must also disclose any lobbying with non-Federal funds that takes place in connection with obtaining any Federal award. Such disclosures are forwarded from tier to tier up to the non-Federal award. See Chapter IV, ¶ 6.c and Appendix C, ¶ 4.
- c. **Statement.** The following statement in bold provides a Byrd Anti-Lobbying contract clause:

**(IF APPLICABLE, PLEASE FILL IN BLANKS AND SIGN)**

**“Byrd Anti-Lobbying Amendment, 31 U.S.C. § 1352 (as amended)**

**Contractors who apply or bid for an award of \$100,000 or more shall file the required certification. Each tier certifies to the tier above that it will not and has not used Federal appropriated funds to pay any person or organization for influencing or attempting to influence an officer or employee of any agency, a member of Congress, officer or employee of Congress, or an employee of a member of Congress in connection with obtaining any Federal contract, grant, or any other award covered by 31 U.S.C. § 1352. Each tier shall also disclose any lobbying with non-Federal funds that takes place in connection with obtaining any Federal award. Such disclosures are forwarded from tier to tier up to the recipient.”**

**APPENDIX A, 44 C.F.R. PART 18 – CERTIFICATION REGARDING LOBBYING**

**Certification for Contracts, Grants, Loans, and Cooperative Agreements**

(To be submitted with each bid or offer exceeding \$100,000)

The undersigned Contractor, \_\_\_\_\_, certifies, to the best of his or her knowledge, that:

1. No Federal appropriated funds have been paid or will be paid, by or on behalf of the undersigned, to any person for influencing or attempting to influence an officer or employee of an agency, a Member of Congress, an officer or employee of Congress, or an employee of a Member of Congress in connection with the awarding of any Federal contract, the making of any Federal grant, the making of any Federal loan, the entering into of any cooperative agreement, and the extension, continuation, renewal, amendment, or modification of any Federal contract, grant, loan, or cooperative agreement.

2. If any funds other than Federal appropriated funds have been paid or will be paid to any person for influencing or attempting to influence an officer or employee of any agency, a Member of Congress, an officer or employee of Congress, or an employee of a Member of Congress in connection with this Federal contract, grant, loan, or cooperative agreement, the undersigned shall complete and submit Standard Form-LLL, "Disclosure Form to Report Lobbying," in accordance with its instructions.

3. The undersigned shall require that the language of this certification be included in the award documents for all subawards at all tiers (including subcontracts, subgrants, and contracts under grants, loans, and cooperative agreements) and that all subrecipients shall certify and disclose accordingly.

This certification is a material representation of fact upon which reliance was placed when this transaction was made or entered into. Submission of this certification is a prerequisite for making or entering into this transaction imposed by 31, U.S.C. § 1352 (as amended by the Lobbying Disclosure Act of 1995). Any person who fails to file the required certification shall be subject to a civil penalty of not less than \$10,000 and not more than \$100,000 for each such failure.

The Contractor, \_\_\_\_\_, certifies or affirms the truthfulness and accuracy of each statement of its certification and disclosure, if any. In addition, the Contractor understands and agrees that the provisions of 31 U.S.C. § 3801 *et seq.*, apply to this certification and disclosure, if any.

\_\_\_\_\_  
Signature of Contractor's Authorized Official

\_\_\_\_\_  
Name and Title of Contractor's Authorized Official

\_\_\_\_\_  
Date

10. **Procurement of Recovered Materials.**

- a. **Applicability:** This requirement applies to all Federal grant and cooperative agreement programs.
- b. **Standard.** A non-Federal entity that is a **state agency or agency of a political subdivision** of a state and its contractors must comply with Section 6002 of the Solid Waste Disposal Act, Pub. L. No. 89-272 (1965) (codified as amended by the Resource Conservation and Recovery Act at 42 U.S.C. § 6962). See 2 C.F.R. Part 200, Appendix II, ¶ J; 2 C.F.R. § 200.322; *PDAT Supplement*, Chapter V, ¶ 7.

The requirements of Section 6002 include procuring only items designated in guidelines of the EPA at 40 C.F.R. Part 247 that contain the highest percentage of recovered materials practicable, consistent with maintaining a satisfactory level of competition, where the purchase price of the item exceeds \$10,000 or the value of the quantity acquired by the preceding fiscal year exceeded \$10,000; procuring solid waste management services in a manner that maximizes energy and resource recovery; and establishing an affirmative procurement program for procurement of recovered materials identified in the EPA guidelines.

- c. **Statement.** The following provides the clause that a state agency or agency of a political subdivision of a state and its contractors can include in contracts meeting the above contract thresholds:

“(1) In the performance of this contract, the Contractor shall make maximum use of products containing recovered materials that are EPA- designated items unless the product cannot be acquired—

- (i) Competitively within a timeframe providing for compliance with the contract performance schedule;
- (ii) Meeting contract performance requirements; or
- (iii) At a reasonable price.

- (3) Information about this requirement, along with the list of EPA-designate items, is available at EPA’s Comprehensive Procurement Guidelines web site, <https://www.epa.gov/smn/comprehensive-procurement-guideline-cpg-program>.”

**Additional Required Contract Clauses for Non-Federal Entity Contracts Under Federal Awards with the Federal Emergency Management Agency (FEMA)**

**Additional FEMA or applicable Federal Requirements.** In addition to the requirements above, non-Federal entity contracts under Federal award subject to financial assistance from FEMA are required to contain the following additional contract clauses. The Uniform Guidance authorizes FEMA to require additional provisions for non-Federal entity contracts. FEMA, pursuant to this authority, requires or recommends the following:

***These clauses are incorporated by reference as part of this procurement packet and any resulting agreement.***

## 11. Changes.

- a. Standard. To be eligible for FEMA assistance under the non-Federal entity's Federal grant or cooperative agreement, the cost of the change, modification, change order, or constructive change must be allowable, allocable, within the scope of its grant or cooperative agreement, and reasonable for the completion of project scope. FEMA or applicable Federal entity recommends, therefore, that a non-Federal entity include a changes clause in its contract that describes how, if at all, changes can be made by either party to alter the method, price, or schedule of the work without breaching the contract. The language of the clause may differ depending on the nature of the contract and the end-item procured.
- b. Statement. The following provides a contract clause regarding access to records:

“The contractor shall secure written authorization before proceeding with any additional work, whether requested by the County or required to complete the contract. The cost for any changes to the contract price, whether requested by the County or the Contractor will be approved only after submitting the contractor's true costs for the work and related equipment costs and site expenses.”

## 12. Access to Records.

- a. Standard. All non-Federal entities must place into their contracts a provision that all contractors and their successors, transferees, assignees, and subcontractors acknowledge and agree to comply with applicable provisions governing Department and FEMA or applicable Federal entity access to records, accounts, documents, information, facilities, and staff. See DHS Standard Terms and Conditions, v 3.0, ¶ XXVI (2013).
- b. Statement. The following provides a contract clause regarding access to records:

“Access to Records. The following access to records requirements apply to this contract:

- (1) The contractor agrees to provide the County of Hidalgo, the FEMA or applicable Federal Administrator, the Comptroller General of the United States, or any of their authorized representatives access to any books, documents, papers, and records of the Contractor which are directly pertinent to this contract for the purposes of making audits, examinations, excerpts, and transcriptions.
- (2) The Contractor agrees to permit any of the foregoing parties to reproduce by any means whatsoever or to copy excerpts and transcriptions as reasonably needed.
- (3) The contractor agrees to provide the FEMA or applicable Federal Administrator or his authorized representatives access to construction or other work sites pertaining to the work being completed under the contract.”

## 13. DHS Seal, Logo, and Flags.

- a. Standard. All non-Federal entities must place in their contracts a provision that a contractor shall not use the DHS seal(s), logos, crests, or reproductions of flags or likenesses of DHS City

officials without specific FEMA or applicable Federal entity pre-approval. See DHS Standard Terms and Conditions, v3.0, ¶ XXV (2013).

b. Statement. The following provides a contract clause regarding DHS Seal, Logo, and Flags:

“The contractor shall not use the DHS seal(s), logos, crests, or reproductions of flags or likenesses of DHS City officials without specific FEMA or applicable Federal entity pre-approval.”

14. Compliance with Federal Law, Regulations, and Executive Orders.

a. Standard. All non-Federal entities must place into their contracts an acknowledgement that FEMA or applicable Federal financial assistance will be used to fund the contract along with the requirement that the contractor will comply with all applicable Federal law, regulations, executive orders, and FEMA or applicable Federal policies, procedures, and directives.

b. Statement. The following provides a contract clause regarding Compliance with Federal Law, Regulations and Executive Orders:

“This is an acknowledgement that Federal financial assistance will be used to fund the contract only. The contractor will comply will all applicable Federal law, regulations, executive orders, FEMA or applicable Federal policies, procedures, and directives.”

15. No Obligation by Federal Government.

a. Standard. The non-Federal entity must include a provision in its contract that states that the Federal Government is not a party to the contract and is not subject to any obligations or liabilities to the non-Federal entity, contractor, or any other party pertaining to any matter resulting from the contract.

b. Statement. The following provides a contract clause regarding no obligation by the Federal Government:

“The Federal Government is not a party to this contract and is not subject to any obligations or liabilities to the non-Federal entity, contractor, or any other party pertaining to any matter resulting from the contract.”

16. Program Fraud and False or Fraudulent Statements or Related Acts.

a. Standard. The non-Federal entity must include a provision in its contract that the contractor acknowledges that 31 U.S.C. Chap. 38 (Administrative Remedies for False Claims and Statements) applies to its actions pertaining to the contract.

b. Statement. The following provides a contract clause regarding Fraud and False or Fraudulent Related Acts:

“The contractor acknowledges that 31 U.S.C. Chap. 38 (Administrative Remedies for False Claims and Statements) applies to the contractor’s actions pertaining to this contract.”

**Contractor agrees to comply with all federal, state and local laws, rules, regulations and ordinances, as applicable. It is further acknowledged that the Contractor read and understands all provisions, laws, acts, regulations, etc. as specifically noted above and certifies compliance with the same.**

Vendor's Name/Company Name: \_\_\_\_\_

Printed Name and Title of Authorized Representative: \_\_\_\_\_

Signature of Authorized Representative: \_\_\_\_\_

Date: \_\_\_\_\_

# Exhibit "I"

**EHWA 1273**

**REQUIRED CONTRACT PROVISIONS  
FEDERAL-AID CONSTRUCTION CONTRACTS**

- I. General
- II. Nondiscrimination
- III. Nonsegregated Facilities
- IV. Davis-Bacon and Related Act Provisions
- V. Contract Work Hours and Safety Standards Act Provisions
- VI. Subletting or Assigning the Contract
- VII. Safety: Accident Prevention
- VIII. False Statements Concerning Highway Projects
- IX. Implementation of Clean Air Act and Federal Water Pollution Control Act
- X. Compliance with Governmentwide Suspension and Debarment Requirements
- XI. Certification Regarding Use of Contract Funds for Lobbying

**ATTACHMENTS**

A. Employment and Materials Preference for Appalachian Development Highway System or Appalachian Local Access Road Contracts (included in Appalachian contracts only)

**I. GENERAL**

1. Form FHWA-1273 must be physically incorporated in each construction contract funded under Title 23 (excluding emergency contracts solely intended for debris removal). The contractor (or subcontractor) must insert this form in each subcontract and further require its inclusion in all lower tier subcontracts (excluding purchase orders, rental agreements and other agreements for supplies or services).

The applicable requirements of Form FHWA-1273 are incorporated by reference for work done under any purchase order, rental agreement or agreement for other services. The prime contractor shall be responsible for compliance by any subcontractor, lower-tier subcontractor or service provider.

Form FHWA-1273 must be included in all Federal-aid design-build contracts, in all subcontracts and in lower tier subcontracts (excluding subcontracts for design services, purchase orders, rental agreements and other agreements for supplies or services). The design-builder shall be responsible for compliance by any subcontractor, lower-tier subcontractor or service provider.

Contracting agencies may reference Form FHWA-1273 in bid proposal or request for proposal documents, however, the Form FHWA-1273 must be physically incorporated (not referenced) in all contracts, subcontracts and lower-tier subcontracts (excluding purchase orders, rental agreements and other agreements for supplies or services related to a construction contract).

2. Subject to the applicability criteria noted in the following sections, these contract provisions shall apply to all work performed on the contract by the contractor's own organization and with the assistance of workers under the contractor's immediate superintendence and to all work performed on the contract by piecework, station work, or by subcontract.

3. A breach of any of the stipulations contained in these Required Contract Provisions may be sufficient grounds for withholding of progress payments, withholding of final payment, termination of the contract, suspension / debarment or any other action determined to be appropriate by the contracting agency and FHWA.

4. Selection of Labor: During the performance of this contract, the contractor shall not use convict labor for any purpose within the limits of a construction project on a Federal-aid highway unless it is labor performed by convicts who are on parole, supervised release, or probation. The term Federal-aid highway does not include roadways functionally classified as local roads or rural minor collectors.

**II. NONDISCRIMINATION**

The provisions of this section related to 23 CFR Part 230 are applicable to all Federal-aid construction contracts and to all related construction subcontracts of \$10,000 or more. The provisions of 23 CFR Part 230 are not applicable to material supply, engineering, or architectural service contracts.

In addition, the contractor and all subcontractors must comply with the following policies: Executive Order 11246, 41 CFR 60, 29 CFR 1625-1627, Title 23 USC Section 140, the Rehabilitation Act of 1973, as amended (29 USC 794), Title VI of the Civil Rights Act of 1964, as amended, and related regulations including 49 CFR Parts 21, 26 and 27; and 23 CFR Parts 200, 230, and 633.

The contractor and all subcontractors must comply with: the requirements of the Equal Opportunity Clause in 41 CFR 60-1.4(b) and, for all construction contracts exceeding \$10,000, the Standard Federal Equal Employment Opportunity Construction Contract Specifications in 41 CFR 60-4.3.

Note: The U.S. Department of Labor has exclusive authority to determine compliance with Executive Order 11246 and the policies of the Secretary of Labor including 41 CFR 60, and 29 CFR 1625-1627. The contracting agency and the FHWA have the authority and the responsibility to ensure compliance with Title 23 USC Section 140, the Rehabilitation Act of 1973, as amended (29 USC 794), and Title VI of the Civil Rights Act of 1964, as amended, and related regulations including 49 CFR Parts 21, 26 and 27; and 23 CFR Parts 200, 230, and 633.

The following provision is adopted from 23 CFR 230, Appendix A, with appropriate revisions to conform to the U.S. Department of Labor (US DOL) and FHWA requirements.

**1. Equal Employment Opportunity:** Equal employment opportunity (EEO) requirements not to discriminate and to take affirmative action to assure equal opportunity as set forth under laws, executive orders, rules, regulations (28 CFR 35, 29 CFR 1630, 29 CFR 1625-1627, 41 CFR 60 and 49 CFR 27) and orders of the Secretary of Labor as modified by the provisions prescribed herein, and imposed pursuant to 23 U.S.C. 140 shall constitute the EEO and specific affirmative action standards for the contractor's project activities under

this contract. The provisions of the Americans with Disabilities Act of 1990 (42 U.S.C. 12101 et seq.) set forth under 28 CFR 35 and 29 CFR 1630 are incorporated by reference in this contract. In the execution of this contract, the contractor agrees to comply with the following minimum specific requirement activities of EEO:

a. The contractor will work with the contracting agency and the Federal Government to ensure that it has made every good faith effort to provide equal opportunity with respect to all of its terms and conditions of employment and in their review of activities under the contract.

b. The contractor will accept as its operating policy the following statement:

"It is the policy of this Company to assure that applicants are employed, and that employees are treated during employment, without regard to their race, religion, sex, color, national origin, age or disability. Such action shall include: employment, upgrading, demotion, or transfer; recruitment or recruitment advertising; layoff or termination; rates of pay or other forms of compensation; and selection for training, including apprenticeship, pre-apprenticeship, and/or on-the-job training."

**2. EEO Officer:** The contractor will designate and make known to the contracting officers an EEO Officer who will have the responsibility for and must be capable of effectively administering and promoting an active EEO program and who must be assigned adequate authority and responsibility to do so.

**3. Dissemination of Policy:** All members of the contractor's staff who are authorized to hire, supervise, promote, and discharge employees, or who recommend such action, or who are substantially involved in such action, will be made fully cognizant of, and will implement, the contractor's EEO policy and contractual responsibilities to provide EEO in each grade and classification of employment. To ensure that the above agreement will be met, the following actions will be taken as a minimum:

a. Periodic meetings of supervisory and personnel office employees will be conducted before the start of work and then not less often than once every six months, at which time the contractor's EEO policy and its implementation will be reviewed and explained. The meetings will be conducted by the EEO Officer.

b. All new supervisory or personnel office employees will be given a thorough indoctrination by the EEO Officer, covering all major aspects of the contractor's EEO obligations within thirty days following their reporting for duty with the contractor.

c. All personnel who are engaged in direct recruitment for the project will be instructed by the EEO Officer in the contractor's procedures for locating and hiring minorities and women.

d. Notices and posters setting forth the contractor's EEO policy will be placed in areas readily accessible to employees, applicants for employment and potential employees.

e. The contractor's EEO policy and the procedures to implement such policy will be brought to the attention of employees by means of meetings, employee handbooks, or other appropriate means.

**4. Recruitment:** When advertising for employees, the contractor will include in all advertisements for employees the notation: "An Equal Opportunity Employer." All such advertisements will be placed in publications having a large circulation among minorities and women in the area from which the project work force would normally be derived.

a. The contractor will, unless precluded by a valid bargaining agreement, conduct systematic and direct recruitment through public and private employee referral sources likely to yield qualified minorities and women. To meet this requirement, the contractor will identify sources of potential minority group employees, and establish with such identified sources procedures whereby minority and women applicants may be referred to the contractor for employment consideration.

b. In the event the contractor has a valid bargaining agreement providing for exclusive hiring hall referrals, the contractor is expected to observe the provisions of that agreement to the extent that the system meets the contractor's compliance with EEO contract provisions. Where implementation of such an agreement has the effect of discriminating against minorities or women, or obligates the contractor to do the same, such implementation violates Federal nondiscrimination provisions.

c. The contractor will encourage its present employees to refer minorities and women as applicants for employment. Information and procedures with regard to referring such applicants will be discussed with employees.

**5. Personnel Actions:** Wages, working conditions, and employee benefits shall be established and administered, and personnel actions of every type, including hiring, upgrading, promotion, transfer, demotion, layoff, and termination, shall be taken without regard to race, color, religion, sex, national origin, age or disability. The following procedures shall be followed:

a. The contractor will conduct periodic inspections of project sites to insure that working conditions and employee facilities do not indicate discriminatory treatment of project site personnel.

b. The contractor will periodically evaluate the spread of wages paid within each classification to determine any evidence of discriminatory wage practices.

c. The contractor will periodically review selected personnel actions in depth to determine whether there is evidence of discrimination. Where evidence is found, the contractor will promptly take corrective action. If the review indicates that the discrimination may extend beyond the actions reviewed, such corrective action shall include all affected persons.

d. The contractor will promptly investigate all complaints of alleged discrimination made to the contractor in connection with its obligations under this contract, will attempt to resolve such complaints, and will take appropriate corrective action within a reasonable time. If the investigation indicates that the discrimination may affect persons other than the complainant, such corrective action shall include such other persons. Upon completion of each investigation, the contractor will inform every complainant of all of their avenues of appeal.

**6. Training and Promotion:**

a. The contractor will assist in locating, qualifying, and increasing the skills of minorities and women who are

applicants for employment or current employees. Such efforts should be aimed at developing full journey level status employees in the type of trade or job classification involved.

b. Consistent with the contractor's work force requirements and as permissible under Federal and State regulations, the contractor shall make full use of training programs, i.e., apprenticeship, and on-the-job training programs for the geographical area of contract performance. In the event a special provision for training is provided under this contract, this subparagraph will be superseded as indicated in the special provision. The contracting agency may reserve training positions for persons who receive welfare assistance in accordance with 23 U.S.C. 140(a).

c. The contractor will advise employees and applicants for employment of available training programs and entrance requirements for each.

d. The contractor will periodically review the training and promotion potential of employees who are minorities and women and will encourage eligible employees to apply for such training and promotion.

**7. Unions:** If the contractor relies in whole or in part upon unions as a source of employees, the contractor will use good faith efforts to obtain the cooperation of such unions to increase opportunities for minorities and women. Actions by the contractor, either directly or through a contractor's association acting as agent, will include the procedures set forth below:

a. The contractor will use good faith efforts to develop, in cooperation with the unions, joint training programs aimed toward qualifying more minorities and women for membership in the unions and increasing the skills of minorities and women so that they may qualify for higher paying employment.

b. The contractor will use good faith efforts to incorporate an EEO clause into each union agreement to the end that such union will be contractually bound to refer applicants without regard to their race, color, religion, sex, national origin, age or disability.

c. The contractor is to obtain information as to the referral practices and policies of the labor union except that to the extent such information is within the exclusive possession of the labor union and such labor union refuses to furnish such information to the contractor, the contractor shall so certify to the contracting agency and shall set forth what efforts have been made to obtain such information.

d. In the event the union is unable to provide the contractor with a reasonable flow of referrals within the time limit set forth in the collective bargaining agreement, the contractor will, through independent recruitment efforts, fill the employment vacancies without regard to race, color, religion, sex, national origin, age or disability; making full efforts to obtain qualified and/or qualifiable minorities and women. The failure of a union to provide sufficient referrals (even though it is obligated to provide exclusive referrals under the terms of a collective bargaining agreement) does not relieve the contractor from the requirements of this paragraph. In the event the union referral practice prevents the contractor from meeting the obligations pursuant to Executive Order 11246, as amended, and these special provisions, such contractor shall immediately notify the contracting agency.

**8. Reasonable Accommodation for Applicants / Employees with Disabilities:** The contractor must be familiar

with the requirements for and comply with the Americans with Disabilities Act and all rules and regulations established there under. Employers must provide reasonable accommodation in all employment activities unless to do so would cause an undue hardship.

**9. Selection of Subcontractors, Procurement of Materials and Leasing of Equipment:** The contractor shall not discriminate on the grounds of race, color, religion, sex, national origin, age or disability in the selection and retention of subcontractors, including procurement of materials and leases of equipment. The contractor shall take all necessary and reasonable steps to ensure nondiscrimination in the administration of this contract.

a. The contractor shall notify all potential subcontractors and suppliers and lessors of their EEO obligations under this contract.

b. The contractor will use good faith efforts to ensure subcontractor compliance with their EEO obligations.

**10. Assurance Required by 49 CFR 26.13(b):**

a. The requirements of 49 CFR Part 26 and the State DOT's U.S. DOT-approved DBE program are incorporated by reference.

b. The contractor or subcontractor shall not discriminate on the basis of race, color, national origin, or sex in the performance of this contract. The contractor shall carry out applicable requirements of 49 CFR Part 26 in the award and administration of DOT-assisted contracts. Failure by the contractor to carry out these requirements is a material breach of this contract, which may result in the termination of this contract or such other remedy as the contracting agency deems appropriate.

**11. Records and Reports:** The contractor shall keep such records as necessary to document compliance with the EEO requirements. Such records shall be retained for a period of three years following the date of the final payment to the contractor for all contract work and shall be available at reasonable times and places for inspection by authorized representatives of the contracting agency and the FHWA.

a. The records kept by the contractor shall document the following:

(1) The number and work hours of minority and non-minority group members and women employed in each work classification on the project;

(2) The progress and efforts being made in cooperation with unions, when applicable, to increase employment opportunities for minorities and women; and

(3) The progress and efforts being made in locating, hiring, training, qualifying, and upgrading minorities and women;

b. The contractors and subcontractors will submit an annual report to the contracting agency each July for the duration of the project, indicating the number of minority, women, and non-minority group employees currently engaged in each work classification required by the contract work. This information is to be reported on Form FHWA-1391. The staffing data should represent the project work force on board in all or any part of the last payroll period preceding the end of July. If on-the-job training is being required by special provision, the contractor

will be required to collect and report training data. The employment data should reflect the work force on board during all or any part of the last payroll period preceding the end of July.

### III. NONSEGREGATED FACILITIES

This provision is applicable to all Federal-aid construction contracts and to all related construction subcontracts of \$10,000 or more.

The contractor must ensure that facilities provided for employees are provided in such a manner that segregation on the basis of race, color, religion, sex, or national origin cannot result. The contractor may neither require such segregated use by written or oral policies nor tolerate such use by employee custom. The contractor's obligation extends further to ensure that its employees are not assigned to perform their services at any location, under the contractor's control, where the facilities are segregated. The term "facilities" includes waiting rooms, work areas, restaurants and other eating areas, time clocks, restrooms, washrooms, locker rooms, and other storage or dressing areas, parking lots, drinking fountains, recreation or entertainment areas, transportation, and housing provided for employees. The contractor shall provide separate or single-user restrooms and necessary dressing or sleeping areas to assure privacy between sexes.

### IV. DAVIS-BACON AND RELATED ACT PROVISIONS

This section is applicable to all Federal-aid construction projects exceeding \$2,000 and to all related subcontracts and lower-tier subcontracts (regardless of subcontract size). The requirements apply to all projects located within the right-of-way of a roadway that is functionally classified as Federal-aid highway. This excludes roadways functionally classified as local roads or rural minor collectors, which are exempt. Contracting agencies may elect to apply these requirements to other projects.

The following provisions are from the U.S. Department of Labor regulations in 29 CFR 5.5 "Contract provisions and related matters" with minor revisions to conform to the FHWA-1273 format and FHWA program requirements.

#### 1. Minimum wages

a. All laborers and mechanics employed or working upon the site of the work, will be paid unconditionally and not less often than once a week, and without subsequent deduction or rebate on any account (except such payroll deductions as are permitted by regulations issued by the Secretary of Labor under the Copeland Act (29 CFR part 3)), the full amount of wages and bona fide fringe benefits (or cash equivalents thereof) due at time of payment computed at rates not less than those contained in the wage determination of the Secretary of Labor which is attached hereto and made a part hereof, regardless of any contractual relationship which may be alleged to exist between the contractor and such laborers and mechanics.

Contributions made or costs reasonably anticipated for bona fide fringe benefits under section 1(b)(2) of the Davis-Bacon Act on behalf of laborers or mechanics are considered wages paid to such laborers or mechanics, subject to the provisions

of paragraph 1.d. of this section; also, regular contributions made or costs incurred for more than a weekly period (but not less often than quarterly) under plans, funds, or programs which cover the particular weekly period, are deemed to be constructively made or incurred during such weekly period. Such laborers and mechanics shall be paid the appropriate wage rate and fringe benefits on the wage determination for the classification of work actually performed, without regard to skill, except as provided in 29 CFR 5.5(a)(4). Laborers or mechanics performing work in more than one classification may be compensated at the rate specified for each classification for the time actually worked therein: Provided, That the employer's payroll records accurately set forth the time spent in each classification in which work is performed. The wage determination (including any additional classification and wage rates conformed under paragraph 1.b. of this section) and the Davis-Bacon poster (WH-1321) shall be posted at all times by the contractor and its subcontractors at the site of the work in a prominent and accessible place where it can be easily seen by the workers.

b. (1) The contracting officer shall require that any class of laborers or mechanics, including helpers, which is not listed in the wage determination and which is to be employed under the contract shall be classified in conformance with the wage determination. The contracting officer shall approve an additional classification and wage rate and fringe benefits therefore only when the following criteria have been met:

(i) The work to be performed by the classification requested is not performed by a classification in the wage determination; and

(ii) The classification is utilized in the area by the construction industry; and

(iii) The proposed wage rate, including any bona fide fringe benefits, bears a reasonable relationship to the wage rates contained in the wage determination.

(2) If the contractor and the laborers and mechanics to be employed in the classification (if known), or their representatives, and the contracting officer agree on the classification and wage rate (including the amount designated for fringe benefits where appropriate), a report of the action taken shall be sent by the contracting officer to the Administrator of the Wage and Hour Division, Employment Standards Administration, U.S. Department of Labor, Washington, DC 20210. The Administrator, or an authorized representative, will approve, modify, or disapprove every additional classification action within 30 days of receipt and so advise the contracting officer or will notify the contracting officer within the 30-day period that additional time is necessary.

(3) In the event the contractor, the laborers or mechanics to be employed in the classification or their representatives, and the contracting officer do not agree on the proposed classification and wage rate (including the amount designated for fringe benefits, where appropriate), the contracting officer shall refer the questions, including the views of all interested parties and the recommendation of the contracting officer, to the Wage and Hour Administrator for determination. The Wage and Hour Administrator, or an authorized representative, will issue a determination within 30 days of receipt and so advise the contracting officer or

will notify the contracting officer within the 30-day period that additional time is necessary.

(4) The wage rate (including fringe benefits where appropriate) determined pursuant to paragraphs 1.b.(2) or 1.b.(3) of this section, shall be paid to all workers performing work in the classification under this contract from the first day on which work is performed in the classification.

c. Whenever the minimum wage rate prescribed in the contract for a class of laborers or mechanics includes a fringe benefit which is not expressed as an hourly rate, the contractor shall either pay the benefit as stated in the wage determination or shall pay another bona fide fringe benefit or an hourly cash equivalent thereof.

d. If the contractor does not make payments to a trustee or other third person, the contractor may consider as part of the wages of any laborer or mechanic the amount of any costs reasonably anticipated in providing bona fide fringe benefits under a plan or program. Provided, That the Secretary of Labor has found, upon the written request of the contractor, that the applicable standards of the Davis-Bacon Act have been met. The Secretary of Labor may require the contractor to set aside in a separate account assets for the meeting of obligations under the plan or program.

## 2. Withholding

The contracting agency shall upon its own action or upon written request of an authorized representative of the Department of Labor, withhold or cause to be withheld from the contractor under this contract, or any other Federal contract with the same prime contractor, or any other federally-assisted contract subject to Davis-Bacon prevailing wage requirements, which is held by the same prime contractor, so much of the accrued payments or advances as may be considered necessary to pay laborers and mechanics, including apprentices, trainees, and helpers, employed by the contractor or any subcontractor the full amount of wages required by the contract. In the event of failure to pay any laborer or mechanic, including any apprentice, trainee, or helper, employed or working on the site of the work, all or part of the wages required by the contract, the contracting agency may, after written notice to the contractor, take such action as may be necessary to cause the suspension of any further payment, advance, or guarantee of funds until such violations have ceased.

## 3. Payrolls and basic records

a. Payrolls and basic records relating thereto shall be maintained by the contractor during the course of the work and preserved for a period of three years thereafter for all laborers and mechanics working at the site of the work. Such records shall contain the name, address, and social security number of each such worker, his or her correct classification, hourly rates of wages paid (including rates of contributions or costs anticipated for bona fide fringe benefits or cash equivalents thereof of the types described in section 1(b)(2)(B) of the Davis-Bacon Act), daily and weekly number of hours worked, deductions made and actual wages paid. Whenever the Secretary of Labor has found under 29 CFR 5.5(a)(1)(v) that the wages of any laborer or mechanic include the amount of any costs reasonably anticipated in providing benefits under a plan or program described in section 1(b)(2)(B) of the Davis-

Bacon Act, the contractor shall maintain records which show that the commitment to provide such benefits is enforceable, that the plan or program is financially responsible, and that the plan or program has been communicated in writing to the laborers or mechanics affected, and records which show the costs anticipated or the actual cost incurred in providing such benefits. Contractors employing apprentices or trainees under approved programs shall maintain written evidence of the registration of apprenticeship programs and certification of trainee programs, the registration of the apprentices and trainees, and the ratios and wage rates prescribed in the applicable programs.

b.(1) The contractor shall submit weekly for each week in which any contract work is performed a copy of all payrolls to the contracting agency. The payrolls submitted shall set out accurately and completely all of the information required to be maintained under 29 CFR 5.5(a)(3)(i), except that full social security numbers and home addresses shall not be included on weekly transmittals. Instead the payrolls shall only need to include an individually identifying number for each employee (e.g., the last four digits of the employee's social security number). The required weekly payroll information may be submitted in any form desired. Optional Form WH-347 is available for this purpose from the Wage and Hour Division Web site at <http://www.dol.gov/esa/whd/forms/wh347instr.htm> or its successor site. The prime contractor is responsible for the submission of copies of payrolls by all subcontractors. Contractors and subcontractors shall maintain the full social security number and current address of each covered worker, and shall provide them upon request to the contracting agency for transmission to the State DOT, the FHWA or the Wage and Hour Division of the Department of Labor for purposes of an investigation or audit of compliance with prevailing wage requirements. It is not a violation of this section for a prime contractor to require a subcontractor to provide addresses and social security numbers to the prime contractor for its own records, without weekly submission to the contracting agency..

(2) Each payroll submitted shall be accompanied by a "Statement of Compliance," signed by the contractor or subcontractor or his or her agent who pays or supervises the payment of the persons employed under the contract and shall certify the following:

(i) That the payroll for the payroll period contains the information required to be provided under §5.5 (a)(3)(ii) of Regulations, 29 CFR part 5, the appropriate information is being maintained under §5.5 (a)(3)(i) of Regulations, 29 CFR part 5, and that such information is correct and complete;

(ii) That each laborer or mechanic (including each helper, apprentice, and trainee) employed on the contract during the payroll period has been paid the full weekly wages earned, without rebate, either directly or indirectly, and that no deductions have been made either directly or indirectly from the full wages earned, other than permissible deductions as set forth in Regulations, 29 CFR part 3;

(iii) That each laborer or mechanic has been paid not less than the applicable wage rates and fringe benefits or cash equivalents for the classification of work performed, as specified in the applicable wage determination incorporated into the contract.

(3) The weekly submission of a properly executed certification set forth on the reverse side of Optional Form WH-347 shall satisfy the requirement for submission of the "Statement of Compliance" required by paragraph 3.b.(2) of this section.

(4) The falsification of any of the above certifications may subject the contractor or subcontractor to civil or criminal prosecution under section 1001 of title 18 and section 231 of title 31 of the United States Code.

c. The contractor or subcontractor shall make the records required under paragraph 3.a. of this section available for inspection, copying, or transcription by authorized representatives of the contracting agency, the State DOT, the FHWA, or the Department of Labor, and shall permit such representatives to interview employees during working hours on the job. If the contractor or subcontractor fails to submit the required records or to make them available, the FHWA may, after written notice to the contractor, the contracting agency or the State DOT, take such action as may be necessary to cause the suspension of any further payment, advance, or guarantee of funds. Furthermore, failure to submit the required records upon request or to make such records available may be grounds for debarment action pursuant to 29 CFR 5.12.

#### 4. Apprentices and trainees

##### a. Apprentices (programs of the USDOL).

Apprentices will be permitted to work at less than the predetermined rate for the work they performed when they are employed pursuant to and individually registered in a bona fide apprenticeship program registered with the U.S. Department of Labor, Employment and Training Administration, Office of Apprenticeship Training, Employer and Labor Services, or with a State Apprenticeship Agency recognized by the Office, or if a person is employed in his or her first 90 days of probationary employment as an apprentice in such an apprenticeship program, who is not individually registered in the program, but who has been certified by the Office of Apprenticeship Training, Employer and Labor Services or a State Apprenticeship Agency (where appropriate) to be eligible for probationary employment as an apprentice.

The allowable ratio of apprentices to journeymen on the job site in any craft classification shall not be greater than the ratio permitted to the contractor as to the entire work force under the registered program. Any worker listed on a payroll at an apprentice wage rate, who is not registered or otherwise employed as stated above, shall be paid not less than the applicable wage rate on the wage determination for the classification of work actually performed. In addition, any apprentice performing work on the job site in excess of the ratio permitted under the registered program shall be paid not less than the applicable wage rate on the wage determination for the work actually performed. Where a contractor is performing construction on a project in a locality other than that in which its program is registered, the ratios and wage rates (expressed in percentages of the journeyman's hourly rate) specified in the contractor's or subcontractor's registered program shall be observed.

Every apprentice must be paid at not less than the rate specified in the registered program for the apprentice's level of progress, expressed as a percentage of the journeymen hourly

rate specified in the applicable wage determination. Apprentices shall be paid fringe benefits in accordance with the provisions of the apprenticeship program. If the apprenticeship program does not specify fringe benefits, apprentices must be paid the full amount of fringe benefits listed on the wage determination for the applicable classification. If the Administrator determines that a different practice prevails for the applicable apprentice classification, fringes shall be paid in accordance with that determination.

In the event the Office of Apprenticeship Training, Employer and Labor Services, or a State Apprenticeship Agency recognized by the Office, withdraws approval of an apprenticeship program, the contractor will no longer be permitted to utilize apprentices at less than the applicable predetermined rate for the work performed until an acceptable program is approved.

##### b. Trainees (programs of the USDOL).

Except as provided in 29 CFR 5.16, trainees will not be permitted to work at less than the predetermined rate for the work performed unless they are employed pursuant to and individually registered in a program which has received prior approval, evidenced by formal certification by the U.S. Department of Labor, Employment and Training Administration.

The ratio of trainees to journeymen on the job site shall not be greater than permitted under the plan approved by the Employment and Training Administration.

Every trainee must be paid at not less than the rate specified in the approved program for the trainee's level of progress, expressed as a percentage of the journeyman hourly rate specified in the applicable wage determination. Trainees shall be paid fringe benefits in accordance with the provisions of the trainee program. If the trainee program does not mention fringe benefits, trainees shall be paid the full amount of fringe benefits listed on the wage determination unless the Administrator of the Wage and Hour Division determines that there is an apprenticeship program associated with the corresponding journeyman wage rate on the wage determination which provides for less than full fringe benefits for apprentices. Any employee listed on the payroll at a trainee rate who is not registered and participating in a training plan approved by the Employment and Training Administration shall be paid not less than the applicable wage rate on the wage determination for the classification of work actually performed. In addition, any trainee performing work on the job site in excess of the ratio permitted under the registered program shall be paid not less than the applicable wage rate on the wage determination for the work actually performed.

In the event the Employment and Training Administration withdraws approval of a training program, the contractor will no longer be permitted to utilize trainees at less than the applicable predetermined rate for the work performed until an acceptable program is approved.

c. Equal employment opportunity. The utilization of apprentices, trainees and journeymen under this part shall be in conformity with the equal employment opportunity requirements of Executive Order 11246, as amended, and 29 CFR part 30.

d. Apprentices and Trainees (programs of the U.S. DOT).

Apprentices and trainees working under apprenticeship and skill training programs which have been certified by the Secretary of Transportation as promoting EEO in connection with Federal-aid highway construction programs are not subject to the requirements of paragraph 4 of this Section IV. The straight time hourly wage rates for apprentices and trainees under such programs will be established by the particular programs. The ratio of apprentices and trainees to journeymen shall not be greater than permitted by the terms of the particular program.

**5. Compliance with Copeland Act requirements.** The contractor shall comply with the requirements of 29 CFR part 3, which are incorporated by reference in this contract.

**6. Subcontracts.** The contractor or subcontractor shall insert Form FHWA-1273 in any subcontracts and also require the subcontractors to include Form FHWA-1273 in any lower tier subcontracts. The prime contractor shall be responsible for the compliance by any subcontractor or lower tier subcontractor with all the contract clauses in 29 CFR 5.5.

**7. Contract termination: debarment.** A breach of the contract clauses in 29 CFR 5.5 may be grounds for termination of the contract, and for debarment as a contractor and a subcontractor as provided in 29 CFR 5.12.

**8. Compliance with Davis-Bacon and Related Act requirements.** All rulings and interpretations of the Davis-Bacon and Related Acts contained in 29 CFR parts 1, 3, and 5 are herein incorporated by reference in this contract.

**9. Disputes concerning labor standards.** Disputes arising out of the labor standards provisions of this contract shall not be subject to the general disputes clause of this contract. Such disputes shall be resolved in accordance with the procedures of the Department of Labor set forth in 29 CFR parts 5, 6, and 7. Disputes within the meaning of this clause include disputes between the contractor (or any of its subcontractors) and the contracting agency, the U.S. Department of Labor, or the employees or their representatives.

**10. Certification of eligibility.**

a. By entering into this contract, the contractor certifies that neither it (nor he or she) nor any person or firm who has an interest in the contractor's firm is a person or firm ineligible to be awarded Government contracts by virtue of section 3(a) of the Davis-Bacon Act or 29 CFR 5.12(a)(1).

b. No part of this contract shall be subcontracted to any person or firm ineligible for award of a Government contract by virtue of section 3(a) of the Davis-Bacon Act or 29 CFR 5.12(a)(1).

c. The penalty for making false statements is prescribed in the U.S. Criminal Code, 18 U.S.C. 1001.

**V. CONTRACT WORK HOURS AND SAFETY STANDARDS ACT**

The following clauses apply to any Federal-aid construction contract in an amount in excess of \$100,000 and subject to the overtime provisions of the Contract Work Hours and Safety Standards Act. These clauses shall be inserted in addition to the clauses required by 29 CFR 5.5(a) or 29 CFR 4.6. As used in this paragraph, the terms laborers and mechanics include watchmen and guards.

**1. Overtime requirements.** No contractor or subcontractor contracting for any part of the contract work which may require or involve the employment of laborers or mechanics shall require or permit any such laborer or mechanic in any workweek in which he or she is employed on such work to work in excess of forty hours in such workweek unless such laborer or mechanic receives compensation at a rate not less than one and one-half times the basic rate of pay for all hours worked in excess of forty hours in such workweek.

**2. Violation; liability for unpaid wages; liquidated damages.** In the event of any violation of the clause set forth in paragraph (1.) of this section, the contractor and any subcontractor responsible therefor shall be liable for the unpaid wages. In addition, such contractor and subcontractor shall be liable to the United States (in the case of work done under contract for the District of Columbia or a territory, to such District or to such territory), for liquidated damages. Such liquidated damages shall be computed with respect to each individual laborer or mechanic, including watchmen and guards, employed in violation of the clause set forth in paragraph (1.) of this section, in the sum of \$10 for each calendar day on which such individual was required or permitted to work in excess of the standard workweek of forty hours without payment of the overtime wages required by the clause set forth in paragraph (1.) of this section.

**3. Withholding for unpaid wages and liquidated damages.** The FHWA or the contracting agency shall upon its own action or upon written request of an authorized representative of the Department of Labor withhold or cause to be withheld, from any moneys payable on account of work performed by the contractor or subcontractor under any such contract or any other Federal contract with the same prime contractor, or any other federally-assisted contract subject to the Contract Work Hours and Safety Standards Act, which is held by the same prime contractor, such sums as may be determined to be necessary to satisfy any liabilities of such contractor or subcontractor for unpaid wages and liquidated damages as provided in the clause set forth in paragraph (2.) of this section.

**4. Subcontracts.** The contractor or subcontractor shall insert in any subcontracts the clauses set forth in paragraph (1.) through (4.) of this section and also a clause requiring the subcontractors to include these clauses in any lower tier subcontracts. The prime contractor shall be responsible for compliance by any subcontractor or lower tier subcontractor with the clauses set forth in paragraphs (1.) through (4.) of this section.

## VI. SUBLETTING OR ASSIGNING THE CONTRACT

This provision is applicable to all Federal-aid construction contracts on the National Highway System.

1. The contractor shall perform with its own organization contract work amounting to not less than 30 percent (or a greater percentage if specified elsewhere in the contract) of the total original contract price, excluding any specialty items designated by the contracting agency. Specialty items may be performed by subcontract and the amount of any such specialty items performed may be deducted from the total original contract price before computing the amount of work required to be performed by the contractor's own organization (23 CFR 635.116).

a. The term "perform work with its own organization" refers to workers employed or leased by the prime contractor, and equipment owned or rented by the prime contractor, with or without operators. Such term does not include employees or equipment of a subcontractor or lower tier subcontractor, agents of the prime contractor, or any other assignees. The term may include payments for the costs of hiring leased employees from an employee leasing firm meeting all relevant Federal and State regulatory requirements. Leased employees may only be included in this term if the prime contractor meets all of the following conditions:

- (1) the prime contractor maintains control over the supervision of the day-to-day activities of the leased employees;
- (2) the prime contractor remains responsible for the quality of the work of the leased employees;
- (3) the prime contractor retains all power to accept or exclude individual employees from work on the project; and
- (4) the prime contractor remains ultimately responsible for the payment of predetermined minimum wages, the submission of payrolls, statements of compliance and all other Federal regulatory requirements.

b. "Specialty items" shall be construed to be limited to work that requires highly specialized knowledge, abilities, or equipment not ordinarily available in the type of contracting organizations qualified and expected to bid or propose on the contract as a whole and in general are to be limited to minor components of the overall contract.

2. The contract amount upon which the requirements set forth in paragraph (f) of Section VI is computed includes the cost of material and manufactured products which are to be purchased or produced by the contractor under the contract provisions.

3. The contractor shall furnish (a) a competent superintendent or supervisor who is employed by the firm, has full authority to direct performance of the work in accordance with the contract requirements, and is in charge of all construction operations (regardless of who performs the work) and (b) such other of its own organizational resources (supervision, management, and engineering services) as the contracting officer determines is necessary to assure the performance of the contract.

4. No portion of the contract shall be sublet, assigned or otherwise disposed of except with the written consent of the contracting officer, or authorized representative, and such consent when given shall not be construed to relieve the contractor of any responsibility for the fulfillment of the contract. Written consent will be given only after the contracting agency has assured that each subcontract is

evidenced in writing and that it contains all pertinent provisions and requirements of the prime contract.

5. The 30% self-performance requirement of paragraph (f) is not applicable to design-build contracts; however, contracting agencies may establish their own self-performance requirements.

## VII. SAFETY: ACCIDENT PREVENTION

This provision is applicable to all Federal-aid construction contracts and to all related subcontracts.

1. In the performance of this contract the contractor shall comply with all applicable Federal, State, and local laws governing safety, health, and sanitation (23 CFR 635). The contractor shall provide all safeguards, safety devices and protective equipment and take any other needed actions as it determines, or as the contracting officer may determine, to be reasonably necessary to protect the life and health of employees on the job and the safety of the public and to protect property in connection with the performance of the work covered by the contract.

2. It is a condition of this contract, and shall be made a condition of each subcontract, which the contractor enters into pursuant to this contract, that the contractor and any subcontractor shall not permit any employee, in performance of the contract, to work in surroundings or under conditions which are unsanitary, hazardous or dangerous to his/her health or safety, as determined under construction safety and health standards (29 CFR 1926) promulgated by the Secretary of Labor, in accordance with Section 107 of the Contract Work Hours and Safety Standards Act (40 U.S.C. 3704).

3. Pursuant to 29 CFR 1926.3, it is a condition of this contract that the Secretary of Labor or authorized representative thereof, shall have right of entry to any site of contract performance to inspect or investigate the matter of compliance with the construction safety and health standards and to carry out the duties of the Secretary under Section 107 of the Contract Work Hours and Safety Standards Act (40 U.S.C.3704).

## VIII. FALSE STATEMENTS CONCERNING HIGHWAY PROJECTS

This provision is applicable to all Federal-aid construction contracts and to all related subcontracts.

In order to assure high quality and durable construction in conformity with approved plans and specifications and a high degree of reliability on statements and representations made by engineers, contractors, suppliers, and workers on Federal-aid highway projects, it is essential that all persons concerned with the project perform their functions as carefully, thoroughly, and honestly as possible. Willful falsification, distortion, or misrepresentation with respect to any facts related to the project is a violation of Federal law. To prevent any misunderstanding regarding the seriousness of these and similar acts, Form FHWA-1022 shall be posted on each Federal-aid highway project (23 CFR 635) in one or more places where it is readily available to all persons concerned with the project:

18 U.S.C. 1020 reads as follows:

"Whoever, being an officer, agent, or employee of the United States, or of any State or Territory, or whoever, whether a person, association, firm, or corporation, knowingly makes any false statement, false representation, or false report as to the character, quality, quantity, or cost of the material used or to be used, or the quantity or quality of the work performed or to be performed, or the cost thereof in connection with the submission of plans, maps, specifications, contracts, or costs of construction on any highway or related project submitted for approval to the Secretary of Transportation; or

Whoever knowingly makes any false statement, false representation, false report or false claim with respect to the character, quality, quantity, or cost of any work performed or to be performed, or materials furnished or to be furnished, in connection with the construction of any highway or related project approved by the Secretary of Transportation; or

Whoever knowingly makes any false statement or false representation as to material fact in any statement, certificate, or report submitted pursuant to provisions of the Federal-aid Roads Act approved July 1, 1916, (39 Stat. 355), as amended and supplemented;

Shall be fined under this title or imprisoned not more than 5 years or both."

#### **IX. IMPLEMENTATION OF CLEAN AIR ACT AND FEDERAL WATER POLLUTION CONTROL ACT**

This provision is applicable to all Federal-aid construction contracts and to all related subcontracts.

By submission of this bid/proposal or the execution of this contract, or subcontract, as appropriate, the bidder, proposer, Federal-aid construction contractor, or subcontractor, as appropriate, will be deemed to have stipulated as follows:

1. That any person who is or will be utilized in the performance of this contract is not prohibited from receiving an award due to a violation of Section 508 of the Clean Water Act or Section 306 of the Clean Air Act.

2. That the contractor agrees to include or cause to be included the requirements of paragraph (1) of this Section X in every subcontract, and further agrees to take such action as the contracting agency may direct as a means of enforcing such requirements.

#### **X. CERTIFICATION REGARDING DEBARMENT, SUSPENSION, INELIGIBILITY AND VOLUNTARY EXCLUSION**

This provision is applicable to all Federal-aid construction contracts, design-build contracts, subcontracts, lower-tier subcontracts, purchase orders, lease agreements, consultant contracts or any other covered transaction requiring FHWA approval or that is estimated to cost \$25,000 or more – as defined in 2 CFR Parts 180 and 1200.

##### **1. Instructions for Certification – First Tier Participants:**

a. By signing and submitting this proposal, the prospective first tier participant is providing the certification set out below.

b. The inability of a person to provide the certification set out below will not necessarily result in denial of participation in this

covered transaction. The prospective first tier participant shall submit an explanation of why it cannot provide the certification set out below. The certification or explanation will be considered in connection with the department or agency's determination whether to enter into this transaction. However, failure of the prospective first tier participant to furnish a certification or an explanation shall disqualify such a person from participation in this transaction.

c. The certification in this clause is a material representation of fact upon which reliance was placed when the contracting agency determined to enter into this transaction. If it is later determined that the prospective participant knowingly rendered an erroneous certification, in addition to other remedies available to the Federal Government, the contracting agency may terminate this transaction for cause of default.

d. The prospective first tier participant shall provide immediate written notice to the contracting agency to whom this proposal is submitted if any time the prospective first tier participant learns that its certification was erroneous when submitted or has become erroneous by reason of changed circumstances.

e. The terms "covered transaction," "debarred," "suspended," "ineligible," "participant," "person," "principal," and "voluntarily excluded," as used in this clause, are defined in 2 CFR Parts 180 and 1200. "First Tier Covered Transactions" refers to any covered transaction between a grantee or subgrantee of Federal funds and a participant (such as the prime or general contract). "Lower Tier Covered Transactions" refers to any covered transaction under a First Tier Covered Transaction (such as subcontracts). "First Tier Participant" refers to the participant who has entered into a covered transaction with a grantee or subgrantee of Federal funds (such as the prime or general contractor). "Lower Tier Participant" refers any participant who has entered into a covered transaction with a First Tier Participant or other Lower Tier Participants (such as subcontractors and suppliers).

f. The prospective first tier participant agrees by submitting this proposal that, should the proposed covered transaction be entered into, it shall not knowingly enter into any lower tier covered transaction with a person who is debarred, suspended, declared ineligible, or voluntarily excluded from participation in this covered transaction, unless authorized by the department or agency entering into this transaction.

g. The prospective first tier participant further agrees by submitting this proposal that it will include the clause titled "Certification Regarding Debarment, Suspension, Ineligibility and Voluntary Exclusion-Lower Tier Covered Transactions," provided by the department or contracting agency, entering into this covered transaction, without modification, in all lower tier covered transactions and in all solicitations for lower tier covered transactions exceeding the \$25,000 threshold.

h. A participant in a covered transaction may rely upon a certification of a prospective participant in a lower tier covered transaction that is not debarred, suspended, ineligible, or voluntarily excluded from the covered transaction, unless it knows that the certification is erroneous. A participant is responsible for ensuring that its principals are not suspended, debarred, or otherwise ineligible to participate in covered transactions. To verify the eligibility of its principals, as well as the eligibility of any lower tier prospective participants, each participant may, but is not required to, check the Excluded Parties List System website (<https://www.eplis.gov/>), which is compiled by the General Services Administration.

i. Nothing contained in the foregoing shall be construed to require the establishment of a system of records in order to render in good faith the certification required by this clause. The knowledge and information of the prospective participant is not required to exceed that which is normally possessed by a prudent person in the ordinary course of business dealings.

j. Except for transactions authorized under paragraph (f) of these instructions, if a participant in a covered transaction knowingly enters into a lower tier covered transaction with a person who is suspended, debarred, ineligible, or voluntarily excluded from participation in this transaction, in addition to other remedies available to the Federal Government, the department or agency may terminate this transaction for cause or default.

\*\*\*\*\*

## 2. Certification Regarding Debarment, Suspension, Ineligibility and Voluntary Exclusion – First Tier Participants:

a. The prospective first tier participant certifies to the best of its knowledge and belief, that it and its principals:

(1) Are not presently debarred, suspended, proposed for debarment, declared ineligible, or voluntarily excluded from participating in covered transactions by any Federal department or agency;

(2) Have not within a three-year period preceding this proposal been convicted of or had a civil judgment rendered against them for commission of fraud or a criminal offense in connection with obtaining, attempting to obtain, or performing a public (Federal, State or local) transaction or contract under a public transaction; violation of Federal or State antitrust statutes or commission of embezzlement, theft, forgery, bribery, falsification or destruction of records, making false statements, or receiving stolen property;

(3) Are not presently indicted for or otherwise criminally or civilly charged by a governmental entity (Federal, State or local) with commission of any of the offenses enumerated in paragraph (a)(2) of this certification; and

(4) Have not within a three-year period preceding this application/proposal had one or more public transactions (Federal, State or local) terminated for cause or default.

b. Where the prospective participant is unable to certify to any of the statements in this certification, such prospective participant shall attach an explanation to this proposal.

## 2. Instructions for Certification - Lower Tier Participants:

(Applicable to all subcontracts, purchase orders and other lower tier transactions requiring prior FHWA approval or estimated to cost \$25,000 or more - 2 CFR Parts 180 and 1200)

a. By signing and submitting this proposal, the prospective lower tier is providing the certification set out below.

b. The certification in this clause is a material representation of fact upon which reliance was placed when this transaction was entered into. If it is later determined that the prospective lower tier participant knowingly rendered an erroneous certification, in addition to other remedies available to the Federal Government, the department, or agency with which

this transaction originated may pursue available remedies, including suspension and/or debarment.

c. The prospective lower tier participant shall provide immediate written notice to the person to which this proposal is submitted if at any time the prospective lower tier participant learns that its certification was erroneous by reason of changed circumstances.

d. The terms "covered transaction," "debarred," "suspended," "ineligible," "participant," "person," "principal," and "voluntarily excluded," as used in this clause, are defined in 2 CFR Parts 180 and 1200. You may contact the person to which this proposal is submitted for assistance in obtaining a copy of those regulations. "First Tier Covered Transactions" refers to any covered transaction between a grantee or subgrantee of Federal funds and a participant (such as the prime or general contract). "Lower Tier Covered Transactions" refers to any covered transaction under a First Tier Covered Transaction (such as subcontracts). "First Tier Participant" refers to the participant who has entered into a covered transaction with a grantee or subgrantee of Federal funds (such as the prime or general contractor). "Lower Tier Participant" refers any participant who has entered into a covered transaction with a First Tier Participant or other Lower Tier Participants (such as subcontractors and suppliers).

e. The prospective lower tier participant agrees by submitting this proposal that, should the proposed covered transaction be entered into, it shall not knowingly enter into any lower tier covered transaction with a person who is debarred, suspended, declared ineligible, or voluntarily excluded from participation in this covered transaction, unless authorized by the department or agency with which this transaction originated.

f. The prospective lower tier participant further agrees by submitting this proposal that it will include this clause titled "Certification Regarding Debarment, Suspension, Ineligibility and Voluntary Exclusion-Lower Tier Covered Transaction," without modification, in all lower tier covered transactions and in all solicitations for lower tier covered transactions exceeding the \$25,000 threshold.

g. A participant in a covered transaction may rely upon a certification of a prospective participant in a lower tier covered transaction that is not debarred, suspended, ineligible, or voluntarily excluded from the covered transaction, unless it knows that the certification is erroneous. A participant is responsible for ensuring that its principals are not suspended, debarred, or otherwise ineligible to participate in covered transactions. To verify the eligibility of its principals, as well as the eligibility of any lower tier prospective participants, each participant may, but is not required to, check the Excluded Parties List System website (<https://www.epls.gov/>), which is compiled by the General Services Administration.

h. Nothing contained in the foregoing shall be construed to require establishment of a system of records in order to render in good faith the certification required by this clause. The knowledge and information of participant is not required to exceed that which is normally possessed by a prudent person in the ordinary course of business dealings.

i. Except for transactions authorized under paragraph e of these instructions, if a participant in a covered transaction knowingly enters into a lower tier covered transaction with a person who is suspended, debarred, ineligible, or voluntarily excluded from participation in this transaction, in addition to other remedies available to the Federal Government, the

department or agency with which this transaction originated may pursue available remedies, including suspension and/or debarment.

\*\*\*\*\*

**Certification Regarding Debarment, Suspension, Ineligibility and Voluntary Exclusion--Lower Tier Participants:**

1. The prospective lower tier participant certifies, by submission of this proposal, that neither it nor its principals is presently debarred, suspended, proposed for debarment, declared ineligible, or voluntarily excluded from participating in covered transactions by any Federal department or agency.

2. Where the prospective lower tier participant is unable to certify to any of the statements in this certification, such prospective participant shall attach an explanation to this proposal.

\*\*\*\*\*

**XI. CERTIFICATION REGARDING USE OF CONTRACT FUNDS FOR LOBBYING**

This provision is applicable to all Federal-aid construction contracts and to all related subcontracts which exceed \$100,000 (49 CFR 20).

1. The prospective participant certifies, by signing and submitting this bid or proposal, to the best of his or her knowledge and belief, that:

a. No Federal appropriated funds have been paid or will be paid, by or on behalf of the undersigned, to any person for influencing or attempting to influence an officer or employee of any Federal agency, a Member of Congress, an officer or employee of Congress, or an employee of a Member of Congress in connection with the awarding of any Federal contract, the making of any Federal grant, the making of any Federal loan, the entering into of any cooperative agreement, and the extension, continuation, renewal, amendment, or modification of any Federal contract, grant, loan, or cooperative agreement.

b. If any funds other than Federal appropriated funds have been paid or will be paid to any person for influencing or attempting to influence an officer or employee of any Federal agency, a Member of Congress, an officer or employee of Congress, or an employee of a Member of Congress in connection with this Federal contract, grant, loan, or cooperative agreement, the undersigned shall complete and submit Standard Form-LLL, "Disclosure Form to Report Lobbying," in accordance with its instructions.

2. This certification is a material representation of fact upon which reliance was placed when this transaction was made or entered into. Submission of this certification is a prerequisite for making or entering into this transaction imposed by 31 U.S.C. 1352. Any person who fails to file the required certification shall be subject to a civil penalty of not less than \$10,000 and not more than \$100,000 for each such failure.

3. The prospective participant also agrees by submitting its bid or proposal that the participant shall require that the language of this certification be included in all lower tier subcontracts, which exceed \$100,000 and that all such recipients shall certify and disclose accordingly.

**ATTACHMENT A - EMPLOYMENT AND MATERIALS PREFERENCE FOR APPALACHIAN DEVELOPMENT HIGHWAY SYSTEM OR APPALACHIAN LOCAL ACCESS ROAD CONTRACTS**

This provision is applicable to all Federal-aid projects funded under the Appalachian Regional Development Act of 1965.

1. During the performance of this contract, the contractor undertaking to do work which is, or reasonably may be, done as on-site work, shall give preference to qualified persons who regularly reside in the labor area as designated by the DOL wherein the contract work is situated, or the subregion, or the Appalachian counties of the State wherein the contract work is situated, except:

a. To the extent that qualified persons regularly residing in the area are not available.

b. For the reasonable needs of the contractor to employ supervisory or specially experienced personnel necessary to assure an efficient execution of the contract work.

c. For the obligation of the contractor to offer employment to present or former employees as the result of a lawful collective bargaining contract, provided that the number of nonresident persons employed under this subparagraph (1c) shall not exceed 20 percent of the total number of employees employed by the contractor on the contract work, except as provided in subparagraph (4) below.

2. The contractor shall place a job order with the State Employment Service indicating (a) the classifications of the laborers, mechanics and other employees required to perform the contract work, (b) the number of employees required in each classification, (c) the date on which the participant estimates such employees will be required, and (d) any other pertinent information required by the State Employment Service to complete the job order form. The job order may be placed with the State Employment Service in writing or by telephone. If during the course of the contract work, the information submitted by the contractor in the original job order is substantially modified, the participant shall promptly notify the State Employment Service.

3. The contractor shall give full consideration to all qualified job applicants referred to him by the State Employment Service. The contractor is not required to grant employment to any job applicants who, in his opinion, are not qualified to perform the classification of work required.

4. If, within one week following the placing of a job order by the contractor with the State Employment Service, the State Employment Service is unable to refer any qualified job applicants to the contractor, or less than the number requested, the State Employment Service will forward a certificate to the contractor indicating the unavailability of applicants. Such certificate shall be made a part of the contractor's permanent project records. Upon receipt of this certificate, the contractor may employ persons who do not normally reside in the labor area to fill positions covered by the certificate, notwithstanding the provisions of subparagraph (1c) above.

5. The provisions of 23 CFR 633.207(e) allow the contracting agency to provide a contractual preference for the use of mineral resource materials native to the Appalachian region.

6. The contractor shall include the provisions of Sections 1 through 4 of this Attachment A in every subcontract for work which is, or reasonably may be, done as on-site work.

# Exhibit "J"

## PROPOSER'S AFFIDAVIT

<b>PROPOSER'S AFFIDAVIT OF NON-COLLUSION NON-CONFLICT OF INTEREST, AND ANTI-LOBBYING</b>
--

STATE OF TEXAS  
COUNTY OF HIDALGO

Affiant, \_\_\_\_\_, being first duly sworn, deposes that:

- (1) Affiant does hereby state neither the proposer nor any of the proposer's officers, partners, owners, agents, representatives, employees, or parties in interest, has in any way colluded, conspired, agreed, directly or indirectly with any person, firm, corporation, or another proposer, or potential proposer, to provide any money or other valuable consideration for assistance in procuring or attempting to procure a contract or fix the prices in the attached proposed or the proposal of any other proposer, and further states that no such money or another reward will be hereinafter paid.
- (2) Affiant further states they have neither recommended nor suggested to Hidalgo County or any of its officials or employees, any of the terms or provisions set forth in their Request for Proposal and subsequent agreement, except at a meeting open to all interested proposers, of which proper notice was given.
- (3) Affiant, further states their officers, employees, or agents have not, and will not attempt to lobby, directly or indirectly, the Hidalgo County Commissioner's Court between proposal submission date and award by the Hidalgo County Commissioner's Court.
- (4) Affiant further states no officer, or stockholder of the proposer is a member of the staff, or related to any employee of Hidalgo County except as noted herein below:

\_\_\_\_\_  
Signature/Title: \_\_\_\_\_

Subscribed and sworn to before me this \_\_\_\_\_ day of \_\_\_\_\_, 2020.

\_\_\_\_\_  
Notary Public

My commission expires: \_\_\_\_\_, 20\_\_\_\_



**HIDALGO COUNTY**

**REQUEST FOR BIDS**

**"Construction of Bus Barn for Hidalgo County Sheriff's Office"**

RFB No.: 2019-267-04-15-ABV

**RFB SUBMITTAL CHECK LIST**

**All forms listed below must be included in the RFB response.**

**Indicate with a check mark (✓) the Forms completed and included in this response:**

\_\_\_\_\_ Page 12 of Legal Notice

\_\_\_\_\_ Total Bid Amount

\_\_\_\_\_ Exhibit "C" -Acknowledgement forms (pages 4 & 5)

\_\_\_\_\_ Exhibit "D" CIQ Form -Copy of County Clerk File Recording fee receipt. (if applicable)

\_\_\_\_\_ Exhibit "E" Vendor Bidder Applications, W-9, & HUB/DBE

\_\_\_\_\_ Exhibit "F" Certification Regarding Debarment

\_\_\_\_\_ Exhibit "H" Required Contract Clauses for Contracts Under Federal award 2 – CFR 200, Appendix II & FEMA (if applicable)

\_\_\_\_\_ Exhibit "J" Proposer's Affidavit

\_\_\_\_\_ SAM.gov Registration Acknowledgement [www.sam.gov](http://www.sam.gov)

\_\_\_\_\_ One (1) Original (pages one-sided, clearly marked ORIGINAL), One (1) Copy of Bid(s), and two (2) CD/USB in PDF Format (see number 2 of Legal Notice).

**EXHIBIT “B”**

**VENDORS BID**

**SECTION 00 41 00  
BID FORM**

**1.01 TO:**

- A. County of Hidalgo  
1. Hidalgo County Purchasing Department, 2802 S. Business Hwy. 281, Edinburg, TX 78539

**1.02 FOR:**

- A. HCSO Bus Barn, Edinburg, TX  
RFB No. #C-18-142-05-08

**1.03 DATE:** 4/15/20 (Bidder to enter date)

**1.04 SUBMITTED BY:** (Bidder to enter name and address)

- A. Bidder's Full Name Celso Gonzalez Construction, Inc.  
Address 614 N Conway Avenue  
City, State, Zip Mission, TX 78572

**1.05 OFFER**

- A. Having examined the Place of The Work and all matters referred to in the Instructions to Bidders and the Contract Documents prepared by Half Associates, Inc. for the above mentioned project, we, the undersigned, hereby offer to enter into a Contract to perform the Work for the items listed in this bid form of:

Two Hundred Five Thousand Dollars + Zero Cents  
dollars (\$205,000.00), in lawful money of the United States of America.

- B. **BID BOND:** Offerors will be required to provide Bid Security in the form of a Bid Bond in the amount of 5 percent of the largest possible total proposal. Failure to provide the Bid Bond with the proposal will constitute a non-responsive proposal and the proposal will not be considered.
- C. **PERFORMANCE AND LABOR & MATERIAL PAYMENT BONDS:** The successful Offeror will be required to provide 100% Performance and Labor and Materials. Payment Bond in strict conformance with all the requirements of the Contract Documents. Failure to do so will result in cancellation of the contract award and forfeiture of the Bid Bond security as liquidated damages.
- D. **NOTE:** Awarded Vendor must provide criminal background clearances through Senate Bill 9 for all personnel and sub-contractors working on the project job site.
- E. All applicable federal taxes are included and State of Texas taxes are included in the Bid Sum.

**1.06 ACCEPTANCE**

- A. This Bidder shall be open to acceptance and is irrevocable for Ninety (90) days from the bid closing date.
- B. If this bid is accepted by County of Hidalgo within the time period stated above, we will:  
Execute the Agreement within seven days of receipt of Notice of Award.  
Furnish the required bonds within seven days of receipt of Notice of Award.

OPENED  
9:47  
4-15-2020  
Witt  

Commence work within seven days after written Notice to Proceed of this bid.

- C. If this bid is accepted within the time stated, and we fail to commence the Work or we fail to provide the required Bond(s), the security deposit shall be forfeited as damages to County of Hidalgo by reason of our failure, limited in amount to the lesser of the face value of the security deposit or the difference between this bid and the bid upon which a Contract is signed.
- D. In the event our bid is not accepted within the time stated above, the required security deposit shall be returned to the undersigned, in accordance with the provisions of the Instructions to Bidders; unless a mutually satisfactory arrangement is made for its retention and validity for an extended period of time.

#### **1.07 CONTRACT TIME**

- A. If the Bid is accepted, project will be substantially complete as follows: Complete the Work in thirty (30) calendar days from Notice to Proceed.
- B. Liquidated Damages: County of Hidalgo has the right under contract to assess liquidated damages for each calendar day beyond the date for substantial completion set out in the contract in which the Work fails to be substantially complete due to unexcused delay. In the event the Contractor fails to achieve Substantial Completion of the work within the time indicated in the Bid Form, or as mutually agreed upon, or as such date may be extended or shortened by approved Change Order, the Owner shall be entitled to liquidated damages in the amount of \$500.00 per day for each day that the work is not substantially complete - the date on the Certificate of Substantial Completion.
- C. In the event the Contractor fails to achieve Final Completion of the Work within ten (10) days of Substantial Completion or as mutually agreed upon, or as such date may be extended or shortened by approved Change Order, the Owner shall be entitled to liquidated damages in the amount of \$500.00 per day that passes within the first seven days past the scheduled Final Completion date in which the Work is not completed; \$1,000.00 per day for each day that passes within the second seven days past the scheduled Final Completion date in which the Work is not completed; and \$1,500.00 per day for each day that passes within the third seven days past the scheduled Final Completion date in which the Work is not completed, until the work is finally completed.
- D. Back Charges: County of Hidalgo has the right under contract to back charge amounts that are spent to complete a portion of the work not completed by the contractor based on schedule and repairs of damage caused by work associated with the construction that requires quick response due to County of Hidalgo operations and contractor has failed to respond. This will be deducted from contractor's contract amount and written as a change order to the contract.
- E. Rain/Off Days: Rain Days must be submitted within 3 days of event or with each pay application (weekly report) failure to provide notification with proper proof within the time period will not be accepted. Any additional days after rain days that the contractor fails to work will be charged as work days unless authorized in writing by both the contractor and Owner, refer to 1.07 Contract Time, A.
- F. Completion of Work  
If this Bid is accepted, we will:  
Complete the Work in 30 calendar days from Notice to Proceed.

#### **1.08 CHANGES TO THE WORK**

- A. All approved change orders must be signed by the Owner and Engineer. Engineer will issue a Proposal Request (PR) to the Contractor; Contractor will prepare detail cost and time information including sub-

contractor breakdown (Change Proposal) and submit to Engineer for review, within 10 days of receipt of the Proposed Change; Engineer will submit proposal and all information to Owner for review and approval.

- B. Allowances shall be handled in a similar manner as a change order, refer to 1.08, B. Contractor shall prepare detail cost and time information and submit to Engineer for review; Engineer will submit proposal and all information to Owner for review and approval.

**1.09 ADDENDA**

- A. The following Addenda have been received. The modifications to the Proposal Documents noted below have been considered and all costs are included in the Proposal Sum.

Addendum # 1 Dated 4/6/20  
Addendum # 2 Dated 4/7/20  
Addendum # 3 Dated 4/7/20  
Addendum # 4 Dated 4/8/20  
Addendum # 5 Dated 4/13/20  
Addendum # 6 Dated 4/13/20

**1.10 BID FORM SIGNATURE(S)**

- A. The Corporate Seal of Celso Gonzalez Construction, Inc.

B. (Bidder - print the full name of your firm)

C. was hereunto affixed in the presence of:

D. Celso Gonzalez Jr., President

E. (Authorized signing officer, Title)

F. (Seal)

G. \_\_\_\_\_

H. (Authorized signing officer, Title)



**1.11 If the Bid is a joint venture or partnership, add additional forms of execution for each member of the joint venture in the appropriate form or forms as above.**

**END OF BID FORM**

**BID SHEET**  
**CONSTRUCTION OF BUS BARN FOR HIDALGO COUNTY SHERIFF'S OFFICE**  
**EDINBURG, TEXAS**

**LOCATION: 711 EL CIBOLO ROAD, EDINBURG TEXAS**

**CONSTRUCTION OF BUS BARN FOR HIDALGO COUNTY SHERIFF'S OFFICE**

	Quantity	Unit	Unit Cost	Cost
1 BUS BARN IMPROVEMENTS	1	LS	\$205,000.00	\$205,000.00
			<b>Sub - Total =</b>	<b>\$205,000.00</b>

**Total = \$205,000.00**

**NOTE:**

- ALL ITEMS ARE TO BE PRICED TO BE COMPLETE IN PLACE AND FULLY FUNCTIONAL WITH ALL ASSOCIATED LABOR INCLUDED.
- 1 INCLUDED.
  - 2 ALL MOBILIZATION, EXPECTED FEES AND PERMITS ARE TO PRICED UNDER VARIES BID ITEMS.
  - 3 ALL ITEMS ON PLANS AND SPECIFICATIONS SHALL BE PRICED WITHIN THIS BID FORM.



# CERTIFICATE OF LIABILITY INSURANCE

DATE (MM/DD/YYYY)

05/19/2020

THIS CERTIFICATE IS ISSUED AS A MATTER OF INFORMATION ONLY AND CONFERS NO RIGHTS UPON THE CERTIFICATE HOLDER. THIS CERTIFICATE DOES NOT AFFIRMATIVELY OR NEGATIVELY AMEND, EXTEND OR ALTER THE COVERAGE AFFORDED BY THE POLICIES BELOW. THIS CERTIFICATE OF INSURANCE DOES NOT CONSTITUTE A CONTRACT BETWEEN THE ISSUING INSURER(S), AUTHORIZED REPRESENTATIVE OR PRODUCER, AND THE CERTIFICATE HOLDER.

IMPORTANT: If the certificate holder is an ADDITIONAL INSURED, the policy(ies) must have ADDITIONAL INSURED provisions or be endorsed. If SUBROGATION IS WAIVED, subject to the terms and conditions of the policy, certain policies may require an endorsement. A statement on this certificate does not confer rights to the certificate holder in lieu of such endorsement(s).

PRODUCER THE KLEMENT AGENCY P.O. BOX 820 PROSPER TX 75078	CONTACT NAME: Greg Klement	FAX (A/C, No): (972) 562-7129	
	PHONE (A/C, No, Ext): (972) 562-7455	E-MAIL ADDRESS: greg@klementagency.com	
INSURED Celso Gonzalez Construction Inc Mr Celso Gonzalez 614 Conway Mission TX 78572-	INSURER(S) AFFORDING COVERAGE		NAIC #
	INSURER A: MT HAWLEY INSURANCE CO		
	INSURER B: TEXAS MUTUAL INS. CO.		
	INSURER C:		
	INSURER D:		
	INSURER E:		

## COVERAGES

CERTIFICATE NUMBER:

REVISION NUMBER:

THIS IS TO CERTIFY THAT THE POLICIES OF INSURANCE LISTED BELOW HAVE BEEN ISSUED TO THE INSURED NAMED ABOVE FOR THE POLICY PERIOD INDICATED. NOTWITHSTANDING ANY REQUIREMENT, TERM OR CONDITION OF ANY CONTRACT OR OTHER DOCUMENT WITH RESPECT TO WHICH THIS CERTIFICATE MAY BE ISSUED OR MAY PERTAIN, THE INSURANCE AFFORDED BY THE POLICIES DESCRIBED HEREIN IS SUBJECT TO ALL THE TERMS, EXCLUSIONS AND CONDITIONS OF SUCH POLICIES. LIMITS SHOWN MAY HAVE BEEN REDUCED BY PAID CLAIMS.

INSR LTR	TYPE OF INSURANCE	ADDL SUBR INSD. WVD	POLICY NUMBER	POLICY EFF (MM/DD/YYYY)	POLICY EXP (MM/DD/YYYY)	LIMITS
A	<input checked="" type="checkbox"/> COMMERCIAL GENERAL LIABILITY <input type="checkbox"/> CLAIMS-MADE <input checked="" type="checkbox"/> OCCUR  GEN'L AGGREGATE LIMIT APPLIES PER: <input type="checkbox"/> POLICY <input checked="" type="checkbox"/> PRO-JECT <input type="checkbox"/> LOC OTHER:		MGL0191200	04/01/2020	04/01/2021	EACH OCCURRENCE \$ 1,000,000 DAMAGE TO RENTED PREMISES (Ea occurrence) \$ 50,000 MED EXP (Any one person) \$ 5,000 PERSONAL & ADV INJURY \$ 1,000,000 GENERAL AGGREGATE \$ 2,000,000 PRODUCTS - COMP/OP AGG \$ 2,000,000 \$
	AUTOMOBILE LIABILITY <input type="checkbox"/> ANY AUTO <input type="checkbox"/> OWNED AUTOS ONLY <input type="checkbox"/> SCHEDULED AUTOS <input type="checkbox"/> HIRED AUTOS ONLY <input type="checkbox"/> NON-OWNED AUTOS ONLY					COMBINED SINGLE LIMIT (Ea accident) \$ BODILY INJURY (Per person) \$ BODILY INJURY (Per accident) \$ PROPERTY DAMAGE (Per accident) \$ \$
	<input type="checkbox"/> UMBRELLA LIAB <input type="checkbox"/> OCCUR <input type="checkbox"/> EXCESS LIAB <input type="checkbox"/> CLAIMS-MADE DED RETENTION \$					EACH OCCURRENCE \$ AGGREGATE \$ \$
B	WORKERS COMPENSATION AND EMPLOYERS' LIABILITY ANY PROPRIETOR/PARTNER/EXECUTIVE OFFICER/MEMBER EXCLUDED? (Mandatory in NH) If yes, describe under DESCRIPTION OF OPERATIONS below	Y/N <input type="checkbox"/> N/A	SBP0001265184-2020	02/14/2020	02/14/2021	<input checked="" type="checkbox"/> PER STATUTE <input type="checkbox"/> OTH-ER E.L. EACH ACCIDENT \$ 1,000,000 E.L. DISEASE - EA EMPLOYEE \$ 1,000,000 E.L. DISEASE - POLICY LIMIT \$ 1,000,000

DESCRIPTION OF OPERATIONS / LOCATIONS / VEHICLES (ACORD 101, Additional Remarks Schedule, may be attached if more space is required)

PROJECT INFORMATION: RFB NO: 2019-267-04-15 ABV

CONSTRUCTION OF BUS BARN FOR HIDALGO COUNTY SHERIFF'S OFFICE. HIDALGO COUNTY SHERIFF'D OFFICE 701 E. EL CIBOLO RD., EDINBURG, TX 78542

## CERTIFICATE HOLDER

## CANCELLATION

AI 119115

HIDALGO COUNTY ATTN: PURCHASING DEPARTMENT 2812 S. HIGHWAY BUS 281 EDINBURG TX 78539-	SHOULD ANY OF THE ABOVE DESCRIBED POLICIES BE CANCELLED BEFORE THE EXPIRATION DATE THEREOF, NOTICE WILL BE DELIVERED IN ACCORDANCE WITH THE POLICY PROVISIONS.
	AUTHORIZED REPRESENTATIVE 

Fax: ( ) -

© 1988-2015 ACORD CORPORATION. All rights reserved.

