

CONSTRUCTION LOAN AGREEMENT

DISASTER RECOVERY HOUSING PROGRAM

This Construction Loan Agreement (this "Agreement"), is entered into effective as **October 12, 2021**, among Borrower, Subrecipient Program Administrator and Contractor who are identified and whose addresses are stated below. This Agreement relates to the manner of disbursement of the loan proceeds on the Participation Agreement for the benefit of Borrower for the rehabilitation and/or renovation of the improvements on the Property under the Subrecipient Program Administrator's Disaster Recovery Housing Program.

BORROWER: **Vicente & Rosa Zamora**

BORROWER'S ADDRESS: **5414 Leigh Ann Dr.
Edinburg, Texas 78542**

SUBRECIPIENT PROGRAM ADMINISTRATOR: County of Hidalgo, a political subdivision
of the State of Texas

SUBRECIPIENT PROGRAM ADMINISTRATOR'S ADDRESS:

County of Hidalgo, Urban County Program
Disaster Recovery Housing Program
1916 Tesoro St.,
Pharr, Texas 78577

CONTRACTOR: **Arnoldo Ochoa**

CONTRACTOR'S ADDRESS: **1301 Cedro St., Penitas Texas 78576**

PROGRAM PROCEEDS:

Renovation and/or rehabilitation to improvements located on the Property (hereinafter defined) according to (i) that certain Disaster Recovery Housing Program Contract (the "Rehabilitation Contract") of even date herewith, entered into by and between Borrower and Program Administrator; (ii) that certain Construction Loan Agreement ("Loan Agreement") of even date herewith, entered into by and between Subrecipient Program Administrator, Borrower, Co-Borrower, and Contractor and payable to the order of Contractor in the original principal amount of **\$88,537.00**; and (iii) that certain Homeowners Certification and Agreement to Participate ("the Certification").

CONTRACT:

The Disaster Recovery Housing Program Construction Loan Agreement.

SECURITY FOR PAYMENT:

This note is secured by (i) the Subrogation Agreement (“Subrogation”) for receipt of funds administered through the Program (ii) a on the Property granted by^[A1] Borrower in favor of Program Administrator in a of even date herewith; and (iii) a mechanic’s and materialmen’s lien on the Property granted by Borrower to (Arnoldo Ochoa) (“Borrower’s Contractor”).

PROPERTY: See Exhibit “A” attached hereto and made a part hereof for all purposes

IMPROVEMENTS:

Renovation and/or rehabilitation to Borrower’s residence located on the Property according to: (i) Plans and Specifications, Timetable and Budget attached hereto as Exhibit “B”; (ii) Disaster Recovery Housing Program Contract, including the Homeowners Certification and Agreement to Participate (“the Certification”), the Subrogation Agreement (“Subrogation”) for receipt of funds administered through the program, and the Subrecipient Participation Agreement, of even date herewith entered into by and between Borrower and Subrecipient Program Administrator; and (iii) the accepted bid submitted to Subrecipient Program Administrator Program Administrator by Contractor.

AMOUNT AVAILABLE FOR CONSTRUCTION: **\$88,537.00**

For good and valuable consideration, the receipt and sufficiency of which are hereby acknowledged, Borrower(s), Subrecipient Program Administrator and Contractor agree as follows:

1. Purpose and Limitation of Payments.

(a) Subject to the provisions of this Agreement, and in compliance with Subchapter K, Chapter 53, Texas Property Code, the Program is a "Contractor's Request for Payment" Payments may be made, from time to time, by Program Administrator to Contractor, up to the face amount of this note, subject to the representations, warranties, covenants, agreements and conditions contained in the Construction Loan Agreement, the Certification agreement, Subrogation agreement. Program Administrator will advance funds to Contractor for the benefit of Borrower in the aggregate amount of the Note. Provided Contractor has obtained the performance bond required in Paragraph 1 (b) of this Agreement, Program Administrator will advance the Amount Available for Construction during the course of the construction of the Improvements, in accordance with this Agreement and the Certification, section-7.f., herein incorporated by reference. The Amount Available for Construction will be advanced solely to pay Contractor for costs of labor performed and materials furnished by Contractor pursuant to the Contract.

(b) Contractor may furnish a performance bond ("Bond"), at Contractor's sole cost and expense, to be kept in force throughout the period of this Agreement, in an amount equal to the Amount Available for Construction. The Bond shall: (i) cover Contractor's faithful performance of the Contract, free of liens upon the Property; (ii) name as obligees both Borrower and Program Administrator, jointly and severally; (iii) be written by surety companies qualified to do business in the State of Texas; and (iv) be in such form and with such sureties as the Program Administrator may approve.

(c) Construction advances are to be made by Program Administrator to Borrower for work done.

(d) If Contractor has provided Program Administrator and Borrower the Bond permitted by this Agreement, Contractor may submit a request for 40% of the Amount Available for Construction ("Initial Advance") when 50% of the work related to the Improvements have been completed and Contractor and Borrower have complied with the provisions of Paragraph 3 of this Agreement. A second request for construction advance for 50% of the Amount Available for Construction ("Final Advance") may be submitted when the Improvements have been completed and accepted by Borrower and Program Administrator and Contractor and Borrower have complied with the provisions of Paragraph 4 of this Agreement.

(e) If Contractor has not provided Program Administrator and Borrower the Bond permitted by this Agreement, Contractor may submit a request for 90% of the Amount Available for Construction when the Improvements have been completed and accepted by Borrower and Program Administrator, and Contractor and Borrower have complied with the provisions of Paragraph 4 (except as to the Bond) of this Agreement.

(f) All requests for construction advances shall comply with Subchapter K, Chapter 53, Texas Property Code, Certification - section 7. f., and be made on forms approved by the Program. Each construction advance shall be in an amount equal to the Amount Available for Construction times the applicable percentage as determined by the Program

Administrator and/or its inspectors. The Program Administrator may prepare a chart for determining the percentage of completion and the schedule of advances to be made by Program Administrator, and Program Administrator may limit advances according to the schedule based on the percentage of the Improvements that are complete at the time of any request for construction advance.

(g) Whenever in the sole opinion of Program Administrator the cost of completing the Improvements pursuant to the plans and specifications approved by Program Administrator exceeds the total amount of unadvanced loan proceeds, Borrower, at Program Administrator's request, shall pay such excess to the satisfaction of Program Administrator prior to any further advances under the Note.

2. Program Administrator's Payments on Behalf of Borrower. Program Administrator shall make payments for the cost of construction of the Improvements by check payable to the Contractor, and in Program Administrator's discretion, following Contractor's default under this Agreement or the Contract, jointly to Contractor and Contractor's subcontractors or suppliers.

3. Conditions to Initial Advance. Program Administrator shall have no obligation to make the Initial Advance of funds to Borrower unless and until Contractor has furnished Borrower and Program Administrator the Bond permitted by this Contract, and the following conditions have been satisfied:

(a) Borrower has executed and delivered to Program Administrator this Agreement, the Contract, Disaster Recovery Housing Program Contract of even date herewith by and between Borrower and Program Administrator, Preconstruction Conference Report and Notice to Proceed other documents securing the loan evidenced by the Promissory Note and Contractor has executed and delivered to Program Administrator this Agreement, the Contract, an Preconstruction Conference Report and Notice to Proceed and other documents securing the loan evidenced by the Note;

(b) Borrower and Contractor have furnished Program Administrator all documents required by Program Administrator to evidence compliance with Subchapter K, Chapter 53, Texas Property Code;

(c) To the extent applicable, Contractor has furnished Program Administrator evidence that Contractor has established a construction account in compliance with Chapter 162, Texas Property Code;

(d) Contractor has provided Program Administrator a copy of the final plans and specifications for the construction of the Improvements acceptable to Program Administrator, along with a timetable and budget for completion of the Improvements as required by this Agreement and the Contractor's accepted bid;

(e) Contractor has provided Program Administrator a copy of the building permit for the Improvements;

(f) Contractor has provided Borrower and Program Administrator a list of all subcontractors used or to be used for completion of the Improvements, and executed partial releases and lien waivers from Contractor and any subcontractors and suppliers who performed work and/or materials at any time in connection with the Improvements, in a form acceptable to Program Administrator, for all amounts to be disbursed to Contractor against the Amount Available for Construction;

(g) Contractor has provided Program Administrator a copy of all insurance policies, which Contractor is required to maintain under the Contract, or in lieu thereof, a certificate of insurance which confirms Contractor has obtained all insurance required under the Contract;

(h) Contractor has provided Program Administrator evidence that Contractor is in compliance with Chapter 416, Texas Property Code; and

(i) Borrower and Contractor have provided Program Administrator such other items as Program Administrator shall reasonably require.

4. Final Advance. The Final Advance (except for retainage, which will be disbursed in accordance with paragraph 5) shall be disbursed at the completion of the Improvements when Contractor has delivered to Program Administrator all documents required under Paragraph 3 and the following:

(a) Conditional Lien Wavier Release executed by Borrower and Contractor (the "Conditional Lien Wavier Release"), a final bills- paid affidavit executed by Contractor (the "Final Bills-Paid Affidavit"), and final waivers of lien and releases executed by Contractor and any subcontractors and suppliers who performed work and/or materials at any time in connection with the Improvements (collectively, the "Releases"), which documents comply with Subchapter K, Chapter 53, Texas Property Code and are acceptable to Program Administrator, together with supporting evidence that: (i) the construction work for the Improvements has been fully completed; and (ii) all bills for labor and material have been paid in full;

(b) Evidence that Borrower and Contractor have complied with all applicable laws pertaining to the location, development, and construction of the Improvements and that all governmental authorities having jurisdiction have approved: (i) the location, development, and construction of the Improvements to the Property; and (ii) all other matters requiring approval by governmental authorities; and

(c) Borrower and Contractor have provided such other items as Program Administrator shall reasonably require.

5. Disbursement of Retainage. The retainage will not be disbursed until: (i) (a) the Releases have been filed in the Real Property Records of Hidalgo County, Texas, (b) the deadline to file an affidavit claiming a lien against the Property in connection with the Improvements (that is, the fifteenth (15th) day of the third calendar month after the day the

indebtedness accrues) has expired and no such affidavits have been filed, or (c) if any affidavits claiming a lien against the Property in connection with the Improvements have been filed, the claims set forth in such affidavits have been resolved and the affidavits have been released of record; (iii) the Affidavit of Completion and the Final Bills-Paid Affidavit have been filed in the Real Property Records of Hidalgo County, Texas; and (iv) Borrower and Contractor have complied with Paragraph 4 of this Agreement.

6. Inspections. Program Administrator shall be entitled to: (i) use its own personnel; or (ii) to designate an architect, engineer or other third party; to make any inspections or certifications required by Program Administrator, and Program Administrator shall not be required to make any loan advance until Program Administrator has received inspections and certifications satisfactory to it. Prior to each loan advance, and at such other times as Program Administrator may require, either Borrower or Contractor will be required to call for a physical inspection by Program Administrator or other party designated by Program Administrator.

7. Borrower's and Contractor's Additional Obligations. Borrower and Contractor further agree that:

(a) The Improvements will be constructed and fully equipped in a good and workmanlike manner with materials of high quality, using all new materials, strictly in accordance with the plans and specifications approved by Program Administrator, and that the Improvements will comply with: (i) all applicable Housing Quality Standards contained in 24 Code of Federal Regulations, as amended, if the Property is located outside the jurisdiction of a municipality; or (ii) all applicable local building codes and ordinances of the municipality if the Property is located within the jurisdiction of a municipality, unless the municipality has no local building codes and ordinances, in which event Owner shall comply with all applicable Housing Quality Standards contained in 24 Code of Federal Regulations, as amended;

(b) No changes will be made in the plans and specifications submitted to Program Administrator except on the written approval of the same by Program Administrator;

(c) No extras shall be allowed to any contractor or subcontractor or any change made in any contract or subcontract without the Program Administrator's prior written approval and consent;

(d) Contractor will promptly furnish Program Administrator, at Program Administrator's request, after execution thereof, executed copies of all contracts between Contractor and subcontractors, and of all contracts between Contractor and its suppliers, as well as contracts between subcontractors and their suppliers;

(e) Borrower and Contractor will cooperate with Program Administrator in arranging for inspections by representatives of Program Administrator of the progress of construction from time to time and will promptly comply with Program Administrator's requirements or satisfy any objections regarding construction of the Improvements or the progress thereof;

(f) Borrower and Contractor will not suffer or permit any mechanics' or materialmen's lien claims to be filed or otherwise asserted against the Property and will promptly discharge the same in case of the filing of any claims for lien or proceedings for the enforcement thereof; provided, however, that Borrower shall have the right to contest in good faith and with reasonable diligence the validity of any such lien or claim on furnishing to Program Administrator such security or indemnity as it may require;

(g) Borrower will pay all real estate taxes and assessments of every kind on the Property before the same become delinquent, and Program Administrator may at any time require Borrower to provide evidence that taxes have been paid current;

(h) In the event that Program Administrator shall expend any amount in performance of any of Borrower's covenants or agreements under the Note or any document securing the Note, such amounts shall constitute additional indebtedness secured under the Contract;

(i) All of the personal property, fixtures, attachments, and equipment delivered on, attached to, or used in connection with the construction of the Improvements or the operation thereof will be kept free and clear of all liens, encumbrances, and security interests whatsoever, and Borrower will be the absolute owner of such personal property, fixtures, attachments, and equipment and Contractor and Borrower will, from time to time, furnish Program Administrator with satisfactory evidence of such ownership, including searches of applicable public records;

(j) Borrower and Contractor will comply with their respective obligations under this Agreement and the Contract and with all applicable laws, rules, ordinances and regulations;

(k) Borrower and Contractor will comply with the Special Conditions, if any, set forth in Exhibit "C" attached hereto;

(l) Contractor will keep accurate and proper books and records of the construction of the Improvements, and will at all reasonable hours allow Program Administrator or its representative to examine such books and records and all contracts and bills relating to the construction of the Improvements.

(m) Contractor shall not discriminate against any employee or applicant for employment because of sex, race, creed, color, national origin or handicap and shall take affirmative action to ensure that during the application process and during employment applicants and employees are treated without regard to their race, creed, color, national origin or handicap. Such action shall include, but not be limited to hiring and employment, upgrading, demotion or transfer, recruitment or recruitment advertising, layoff or termination, rates of pay or other forms of compensation; and selection for training, including apprenticeship. Contractor shall continuously post in conspicuous places, readily available to employees and applicants for employment, notices to be provided or approved by the County of Hidalgo, setting forth the provisions of this non-discrimination provision and such other notices as may be required by law.

8. Actions For Program Administrator's Benefit Only. **THE AUTHORITY HEREIN CONFERRED ON PROGRAM ADMINISTRATOR AND ANY ACTION TAKEN BY PROGRAM ADMINISTRATOR IN MAKING INSPECTIONS OF THE PROPERTY, PROCURING SWORN STATEMENTS AND WAIVERS OF LIENS, APPROVING CONTRACTS AND SUBCONTRACTS AND APPROVING PLANS AND SPECIFICATIONS WILL BE TAKEN BY PROGRAM ADMINISTRATOR FOR ITS OWN PROTECTION ONLY, AND PROGRAM ADMINISTRATOR SHALL NOT BE DEEMED TO HAVE ASSUMED ANY RESPONSIBILITY TO BORROWER OR ANY OTHER PERSON WITH RESPECT TO ANY SUCH ACTION HEREIN AUTHORIZED OR TAKEN BY PROGRAM ADMINISTRATOR OR WITH RESPECT TO THE PROPER CONSTRUCTION OF THE IMPROVEMENTS, PERFORMANCE OF CONTRACTS OR SUBCONTRACTS BY ANY CONTRACTORS OR SUBCONTRACTORS, OR PREVENTION OF CLAIMS FOR MECHANIC'S LIEN.**

9. Non-Waiver By the Program Administrator. No waiver of any breach or default hereunder shall constitute or be construed as a waiver by Program Administrator of any subsequent breach or default or of any breach or default of any other provision. No waiver of any term or provision of this Agreement shall be binding unless executed in writing by the party entitled to the benefit thereof. Pursuit by Program Administrator of any remedies set forth in this Agreement does not preclude pursuit by Program Administrator of other remedies in this Agreement or provided by law.

10. Conflict of Interest. **BORROWER AND CONTRACTOR REPRESENT AND WARRANT TO PROGRAM ADMINISTRATOR THAT, TO THE BEST OF THEIR KNOWLEDGE, NO EMPLOYEE, AGENT, CONSULTANT, OFFICER, OR ELECTED OR APPOINTED OFFICIAL OF PROGRAM ADMINISTRATOR WHO EXERCISES OR HAS EXERCISED ANY FUNCTIONS OR RESPONSIBILITIES WITH RESPECT TO THE ACTIVITIES ASSISTED WITH THE PROGRAM ADMINISTRATOR'S OWNER-OCCUPIED REHABILITATION LOAN PROGRAM OR WHO ARE IN A POSITION TO PARTICIPATE IN A DECISION MAKING PROCESS OR GAIN INSIDE INFORMATION WITH REGARD TO THESE ACTIVITIES, DURING THEIR TENURE OR WITHIN ONE YEAR THEREAFTER, HAS A FINANCIAL INTEREST OR BENEFIT IN THE LOAN RELATED TO THIS AGREEMENT, OR THE PROCEEDS THEREUNDER, EITHER FOR THEMSELVES OR THOSE WITH WHOM THEY HAVE FAMILY OR BUSINESS TIES.**

11. Dispute Resolution. All disputes between Contractor and Borrower regarding the construction project which is the subject of this Agreement, including, but not limited to, all disputes with regard to the Contract and this Agreement, shall, in the first instance, be submitted, in writing, with supporting documentation, within ten (10) days of the incident giving rise to the dispute, to Program Administrator's program director having responsibility for the Program Administrator's owner-occupied rehabilitation loan program for resolution. Except for good cause shown, any dispute not submitted within such ten (10) day period shall be deemed waived. While a dispute is pending, Contractor and Borrower shall otherwise proceed to perform all obligations under the Contract and this Agreement not otherwise in dispute.

12. Sole and Only Agreement. This Agreement and its exhibits and the instruments executed in connection therewith constitute the sole and only agreement of the parties hereto and supersedes any prior understandings or written or oral agreements between the parties respecting the within subject matter.

13. Severability. If one or more provisions of this Agreement are held to be unenforceable under applicable law, such provisions shall be excluded from this Agreement and the balance of this Agreement shall be interpreted as if such provisions were so excluded and shall be enforceable in accordance with its terms.

14. Interpretation. No provision of this Agreement will be interpreted in favor of, or against, any of the parties hereto by reason of the extent to which any such party or its counsel participated in the drafting thereof or by reason of the extent to which any such provision is inconsistent with any prior draft hereof or thereof. In the event of a conflict between this Agreement, the Mechanic's Lien Contract and/or the Rehabilitation Contract, the provisions in the document containing the most stringent requirement for the matter in dispute shall control

15. Jurisdiction and Venue. The parties agree that any suit, action or proceeding brought by a party against the other in connection with or arising from this Agreement ("Judicial Action") shall be brought only in any United States Federal or Texas state court located in Hidalgo County,

Texas and the parties hereby consent to the exclusive jurisdiction of such courts (and the appropriate appellate courts) in any such Judicial Action and waives any objection to venue laid therein. If either party is a prevailing party in a Judicial Action, such party is entitled to recover from the non-prevailing party all costs of such proceeding and reasonable attorney's fees.

16. Additional Documents. The parties hereto covenant and agree that they will execute each such other and further instruments and documents as are or may become necessary or convenient to effectuate and carry out the terms of this contract.

17. Independent Contractor. It is expressly agreed that this contract and the performance by the parties hereunder does not create any agency relationship or master-servant relationship that Program Administrator has no direct supervision of the performance of the services provided by Contractor, and that Contractor is an independent contractor under this Contract.

18. Termination. Program Administrator may terminate this agreement without cause and for convenience upon thirty (30) days written notice. Program Administrator reserves the right to terminate the Construction Loan Agreement for default if Contractor breaches any of the terms therein, including warranties of Contractor or if Contractor becomes insolvent or commits acts of bankruptcy. Such right of termination is in addition to and not in lieu of any other remedies which Program Administrator may have in law or equity.

Default may be construed as, but not limited to, failure to deliver the proper goods/or services with the proper amount of time, and/or to properly perform any and all services required to the Program Administrators satisfaction and/or meet all other obligations and requirements.

19. Insurance. Consistent with its status as an independent contractor and at its sole expense, Contractor agrees that throughout the duration of the work under this contract and any extension hereof, it shall provide and maintain any and all insurances and abide by any requirements which may be necessary in providing services or are otherwise required by law. Insurance policies shall cover, but are not limited to, Contractor's activities and all persons, vehicles, equipment and property connected with providing services, to include theft or loss. The amount of insurance required shall be in accordance with amounts specified by the Program Administrator or as prescribed by law, but in no event shall any amount be less than the minimum amounts prescribed by law, including, but not limited to the Texas Tort Claims Act. Any and all applicable insurance requirements and amounts are incorporated herein by reference for all purposes. Contractor is responsible for ensuring all required insurance policies are valid for the duration of the contract. All insurance policies are to be issued by an insurance company authorized to do business in the State of Texas and acceptable to Program Administrator. Contractor shall cause all subcontractors utilized by Contractor to also comply with these specifications. Contractor shall furnish to Program Administrator certificate(s) of coverage, and all renewals throughout the duration of the Project, issued by the insurer that such insurance is in full force and effect upon request. For each applicable policy, Contractor shall name the Program Administrator as an additional insured. Contractor shall notify Program Administrator a minimum of thirty (30) days in advance of cancellation of all or part of a policy. Contractor shall make any other insurance documentation available to Program Administrator upon request.

20. Indemnification. Contractor shall indemnify and hold harmless Program Administrator, its elected officials, employees and agents from any and all claims, damages, losses, and expenses including attorney's fees for the defense of any action against Program Administrator arising out of, resulting from, or connected with the provision of the service by Contractor under this Contract. Said indemnity shall cover any act or failure to act by the Contractor, its agents or employees.

21. Immunities. Nothing in this Agreement is intended to and Program Administrator does not hereby waive, release or relinquish any right to assert any of the defenses Program Administrator enjoys by virtue of the state or federal constitution, laws, rules or regulations, and any sovereign, official or qualified immunity available to Program Administrator as to any claim or action of any person, entity, or individual against Program Administrator.

21. General Provisions. This Agreement:

- a. may not be assigned by Borrower or Contractor without the prior written consent of Program Administrator;
- b. may not be amended or modified, in whole or in part, unless such amendment or modification is executed in writing by both parties;
- c. binds and insures to the benefit of the parties and their respective heirs, successors and permitted assigns; and

- d. is for the sole benefit of the parties hereto and their respective heirs, successors and permitted assigns. Nothing herein shall give, or be construed to give, any legal or equitable rights hereunder to any other person or entity other than the parties hereto and their respective heirs, successors and permitted assigns.

Required Contract Provision for Contracts Subject to Federal Award (if applicable)

Pursuant to 2 CFR 200.326, a non-federal entity's contracts must contain the applicable provisions described in appendix II to 2 CFR 200-Contract Provisions for non-Federal Entity Contracts under Federal Awards. Additionally, County contracts under Federal award which are subject to assistance from the Federal Emergency Management Agency (FEMA) are also required to contain additional contract clauses. The applicable required contract clauses are attached hereto as Exhibit "D", and are incorporated herein and made part of this agreement for all purposes.

NOTICE

ANY HOLDER OF THIS CONSUMER CREDIT CONTRACT IS SUBJECT TO ALL CLAIMS AND DEFENSES WHICH THE DEBTOR COULD ASSERT AGAINST THE SELLER OF GOODS OR SERVICES OBTAINED PURSUANT HERETO OR WITH THE PROCEEDS HEREOF. RECOVERY HEREUNDER BY THE DEBTOR SHALL NOT EXCEED AMOUNTS PAID BY THE DEBTOR HEREUNDER.

IMPORTANT NOTICE: YOU AND YOUR CONTRACTOR ARE RESPONSIBLE FOR MEETING THE TERMS AND CONDITIONS OF THIS CONTRACT. IF YOU SIGN THIS CONTRACT AND YOU FAIL TO MEET THE TERMS AND CONDITIONS OF THIS CONTRACT, YOU MAY LOSE YOUR LEGAL OWNERSHIP RIGHTS IN YOUR HOME. KNOW YOUR RIGHTS AND DUTIES UNDER THE LAW.

RESIDENTIAL CONSTRUCTION LIABILITY ACT (RCLA) NOTICE

This contract is subject to Chapter 27 of the Texas Property Code. The provisions of that chapter may affect your right to recover damages arising from the performance of this contract. If you have a complaint concerning a construction defect arising from the performance of this contract and that defect has not been corrected through normal warranty service, you must provide the notice required by Chapter 27 of the Texas Property Code to the contractor by certified mail, return receipt requested, not later than the 60th day before the date you file suit to recover damages in a court of law or initiate arbitration. The notice must refer to Chapter 27 of the Texas Property Code and must describe the construction defect. If requested by the contractor, you must provide the contractor an opportunity to inspect and cure the defect as provided by Section 27.004 of the Texas Property Code.

BORROWER(S):

Vicente Zamora

Rosa Zamora

YOU, THE OWNER, MAY CANCEL THIS TRANSACTION AT ANY TIME BEFORE MIDNIGHT OF THE THIRD BUSINESS DAY AFTER THE DATE OF THIS TRANSACTION. SEE THE ATTACHED NOTICE OF CANCELLATION FORM FOR AN EXPLANATION OF THIS RIGHT.

PROGRAM ADMINISTRATOR:

COUNTY OF HIDALGO, a political subdivision
of the State of Texas

By: **Patricio R. Avila**
Its: **Director of Urban County Program**

CONTRACTOR:

By: **Arnoldo Ochoa**
Its: **8/A Builders, LLC**

APPROVED AS TO FORM
Hidalgo County Office of the Criminal District Attorney
Ricardo Rodriguez, Jr.,

By: _____
Victor M. Garza, Assistant District Attorney

STATE OF TEXAS §
 §
COUNTY OF HIDALGO §

This instrument was acknowledged before me on this _____ day of _____, 2021 by **Patricio R. Avila, Director of Urban County Program of the County of Hidalgo**, a political subdivision of the State of Texas, on behalf of said political subdivision.

NOTARY PUBLIC, STATE OF TEXAS

STATE OF TEXAS §
 §
COUNTY OF HIDALGO §

This instrument was acknowledged before me on this _____ by **Vicente & Rosa Zamora**

NOTARY PUBLIC, STATE OF TEXAS

STATE OF TEXAS §
 §
COUNTY OF HIDALGO §

This instrument was acknowledged before me on this _____ by **Arnoldo Ochoa.**

NOTARY PUBLIC, STATE OF TEXAS

YOU MAY CANCEL THIS TRANSACTION, WITHOUT ANY PENALTY OR OBLIGATION, WITHIN THREE BUSINESS DAYS FROM THE ABOVE DATE.

IF YOU CANCEL, ANY PROPERTY TRADED IN, ANY PAYMENTS MADE BY YOU UNDER THE CONTRACT OR SALE, AND ANY NEGOTIABLE INSTRUMENT EXECUTED BY YOU WILL BE RETURNED WITHIN TEN BUSINESS DAYS FOLLOWING RECEIPT BY THE MERCHANT OF YOUR CANCELLATION NOTICE, AND ANY SECURITY INTEREST ARISING OUT OF THE TRANSACTION WILL BE CANCELED.

IF YOU CANCEL YOU MUST MAKE AVAILABLE TO THE MERCHANT AT YOUR RESIDENCE, IN SUBSTANTIALLY AS GOOD CONDITION AS WHEN RECEIVED, ANY GOODS DELIVERED TO YOU UNDER THIS CONTRACT OR SALE; OR YOU MAY IF YOU WISH, COMPLY WITH THE INSTRUCTIONS OF THE MERCHANT REGARDING THE RETURN SHIPMENT OF THE GOODS AT THE MERCHANT'S EXPENSE AND RISK.

IF YOU DO NOT AGREE TO RETURN THE GOODS TO THE MERCHANT OR IF THE MERCHANT DOES NOT PICK THEM UP WITHIN TWENTY DAYS OF THE DATE OF YOUR NOTICE OF CANCELLATION, YOU MAY RETAIN OR DISPOSE OF THE GOODS WITHOUT ANY FURTHER OBLIGATION.

TO CANCEL THIS TRANSACTION, MAIL OR DELIVER A SIGNED AND DATED COPY OF THIS CANCELLATION NOTICE OR ANY OTHER WRITTEN NOTICE, OR SEND A TELEGRAM, TO ARNOLDO OCHOA & 8/A BUILDERS, LLC 1301 CEDRO ST., PENITAS TEXAS 78576 NOT LATER THAN MIDNIGHT OF OCTOBER 14, 2021.

I HEREBY CANCEL THIS TRANSACTION.

Dated: _____.

BORROWER(S):

Vicente Zamora

Rosa Zamora

EXHIBIT "A"
LEGAL DESCRIPTION OF THE PROPERTY

Lot 26 Alamo Estates, Hidalgo County Texas

EXHIBIT "B"
PLANS AND SPECIFICATIONS,
TIMETABLE
AND
BUDGET

ZAMORA RESIDENCE

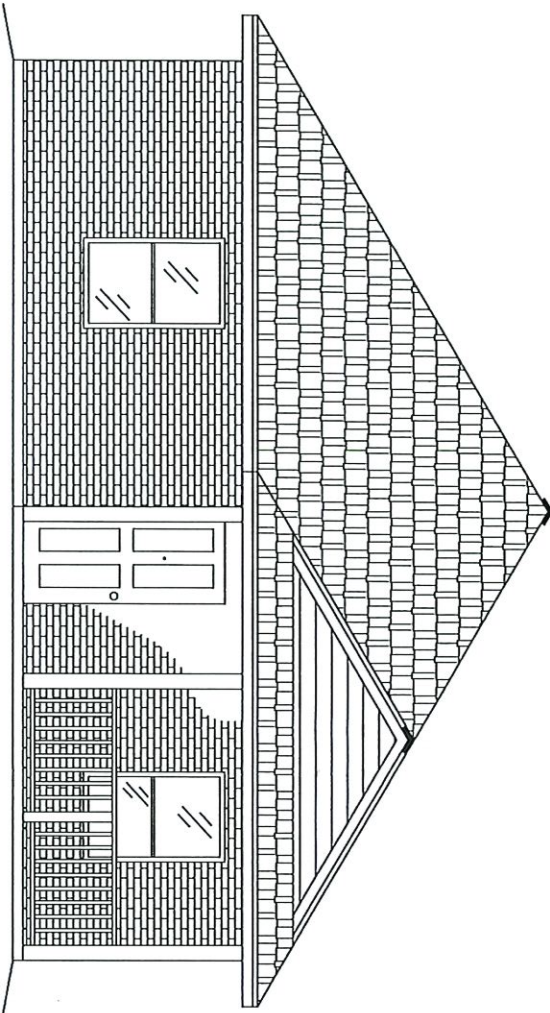

VICENTE ZAMORA
 5414 LEIGH ANN DR.
 EDINBURG, TEXAS 78542
 CELL: 956-328-4159

URBAN COUNTY PROGRAM
 1916 TESORO ST PHARR TX 78577
 (956) 787-8127

GENERAL NOTES

1. Building to comply w/ 2015 IRC, 2015 IECC, and other city ordinances.
2. All construction must be done per design and specifications.

GENERAL NOTES

- 7/12 SLOPE WITH 18" OVERHANG
- SUPPLY ROOF / SCOFF VENTS WHERE NEEDED
- INSTALL PORCH RAILING WHERE FINISH GRADE IS LOWER THAN 1" FROM PORCH FLOOR
- INSTALL PORCH STEPS WHERE FINISH GRADE IS LOWER THAN 6" FROM PORCH FLOOR
- CLIENT RESPONSIBLE FOR GAS AND ELECTRIC SERVICE
- INSTALL WORK OF TWO PHONE JACKS & CABLE CONNECTIONS AS PER OWNER'S REQUEST
- EXTERIOR COLOR CHOICES TO BE OR MATCH

INTERIOR COLOR CHOICES TO BE OR MATCH:
 SW 7080
 SW 6047

I HAVE READ AND FULLY AGREE WITH

THE WRITE-UP AND PLANS AS PRESENTED
 TO ME THIS 16th DAY OF Sept. 2024

Vicente Zamora
 Vicente Zamora

URBAN COUNTY PROGRAM
 OWNER OCCUPIED HOUSING REHABILITATION PROGRAM

VICENTE ZAMORA
 5414 LEIGH ANN DR. Edinburg Tx. 78542

TOTAL AREA
 1376 SQ. FT.

C1.0

1 ROOF/PLOT PLAN
SCALE: 1"=30'

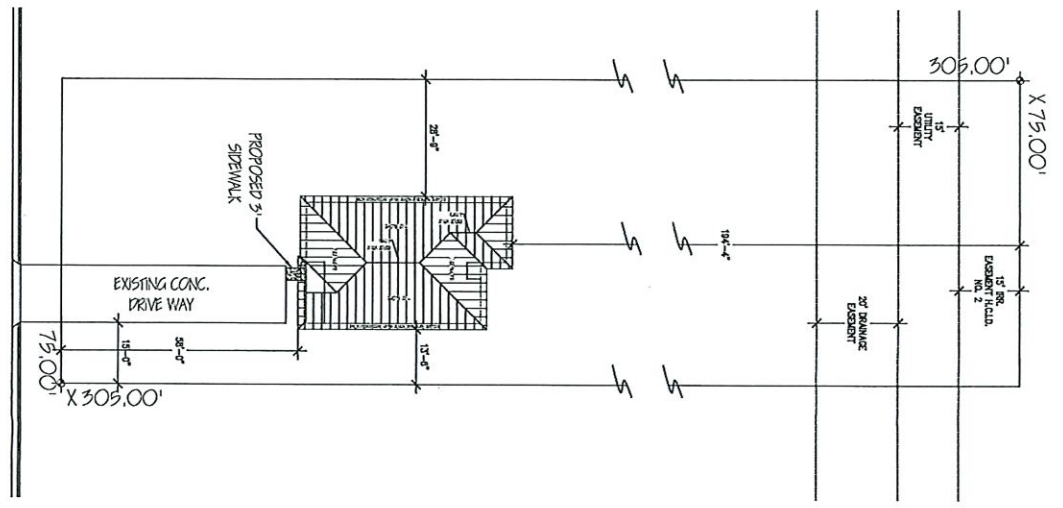

- NOTE:**
1. Please verify with city/ county on setbacks and for any requirements regarding sidewalk, driveway, landscaping, and any other obligations as per city regulations/ ordinances.
 2. It is the responsibility of the Contractor to locate the rods and string the property. To avoid any problems it is now required and the responsibility of the Contractor to order a property survey by a professional engineer.
 3. Any house that is made for handicap accessibility WILL ALWAYS require driveway with connecting sidewalk.
 4. Provide 6" of landscape dirt around house with sufficient grass seed up to 10' of perimeter. In addition, remember to replace septic tank if needed and is more than 10 yrs old.
 5. Contractor is responsible to replace or repair any sidewalks or gates damaged or removed during demolition.
 6. Contractor is responsible to verify all dimensions & Coordinate placement of house and no-step sidewalk with existing driveway and sidewalk.

URBAN COUNTY PROGRAM
OWNER OCCUPIED HOUSING REHABILITATION PROGRAM

VICENTE ZAMORA
5414 LEIGH ANN DR. Edinburg Tx. 78542

AS1.1

TOTAL AREA
1376 SQ. FT.

1 FLOOR PLAN
SCALE: 3/16"=1'-0"

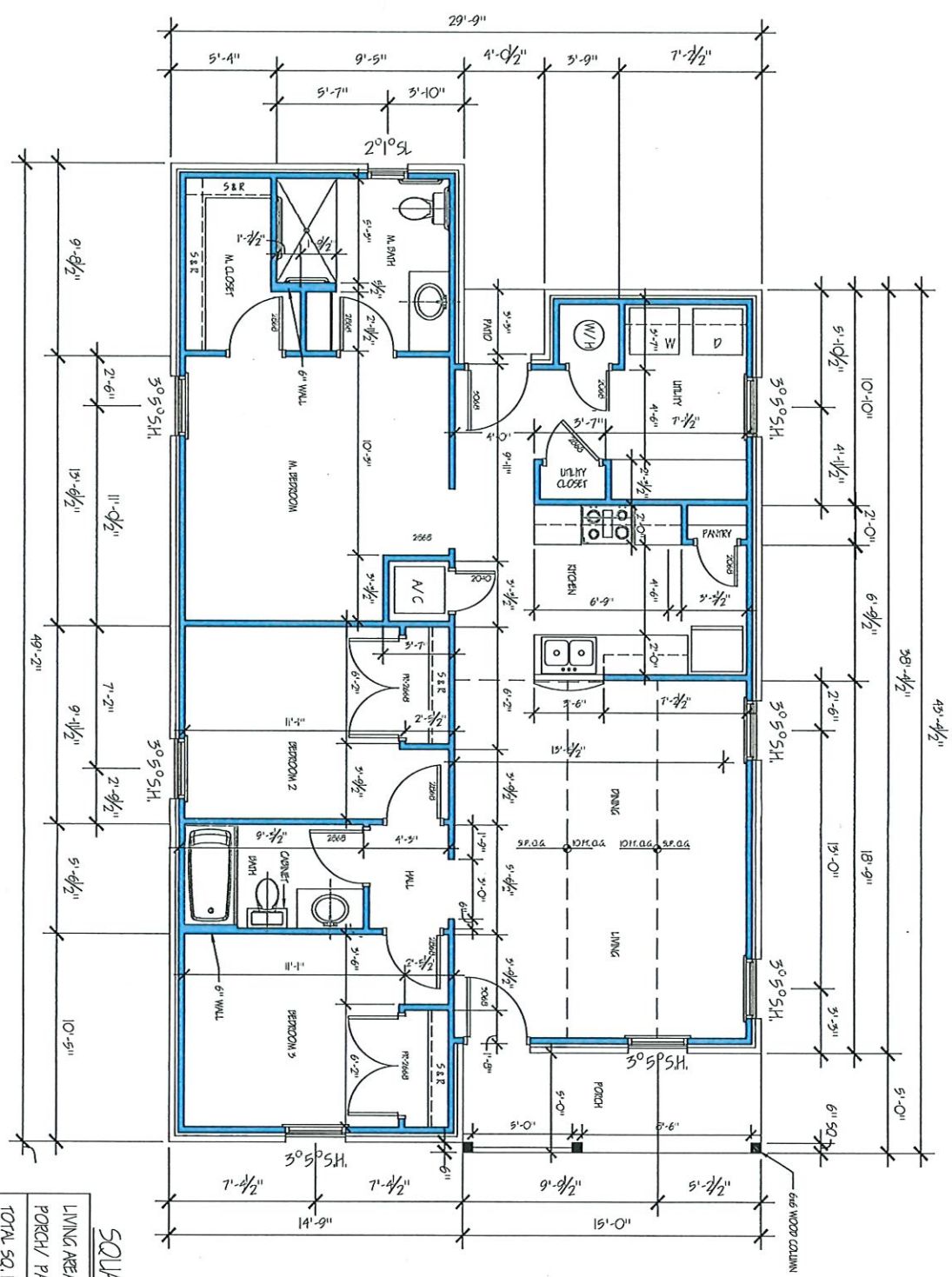

SQUARE FOOTAGE

LIVING AREA	1,284
PORCH / PATIO	92
TOTAL SQ. FT.	1,376

URBAN COUNTY PROGRAM
OWNER OCCUPIED HOUSING REHABILITATION PROGRAM

VICENTE ZAMORA
5414 LEIGH ANN DR. Edinburg Tx. 78542

TOTAL AREA
1376 SQ. FT.

2 REAR ELEVATION

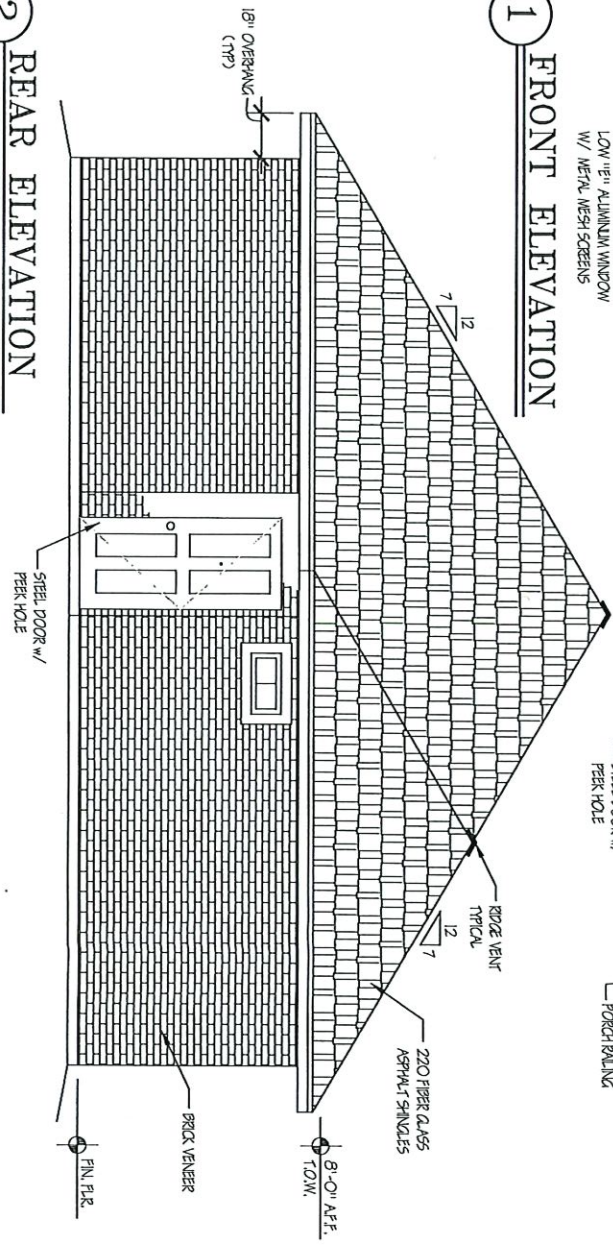

1 FRONT ELEVATION

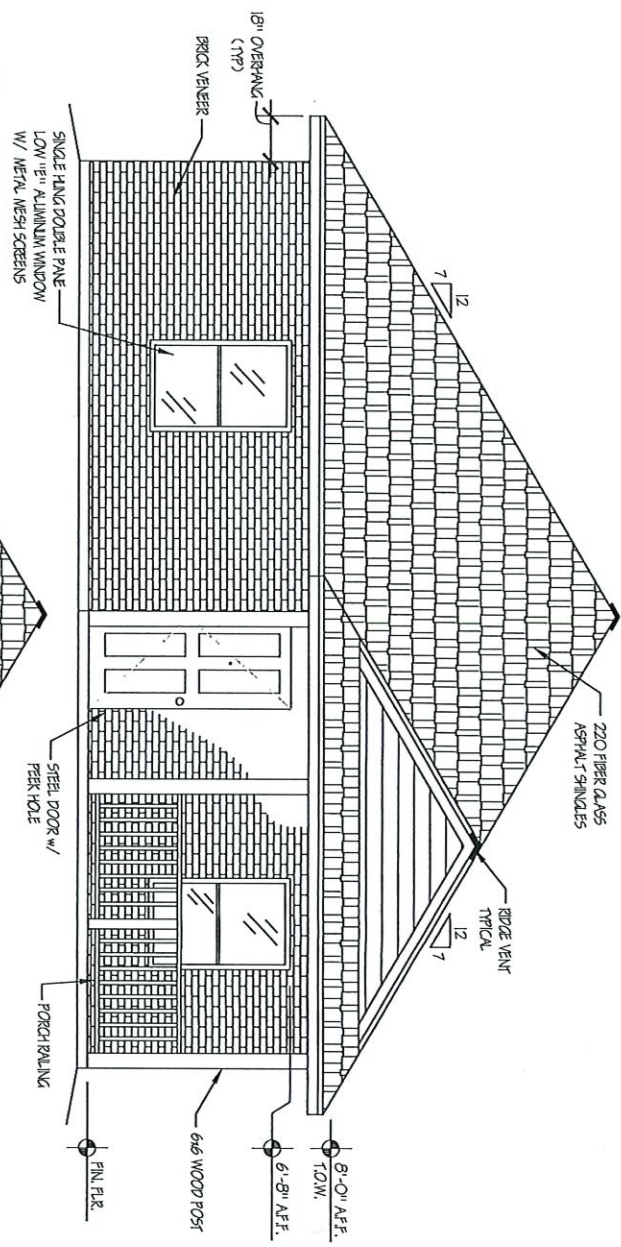

3 TYP. WALL SECTION

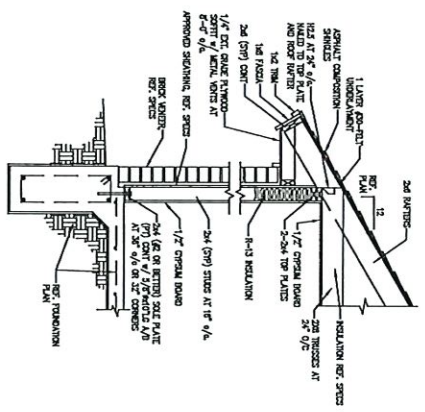

URBAN COUNTY PROGRAM
OWNER OCCUPIED HOUSING REHABILITATION PROGRAM

VICENTE ZAMORA
5414 LEIGH ANN DR. Edinburg Tx. 78542

A1.2

TOTAL AREA
1376 SQ. FT.

2 RIGHT ELEVATION

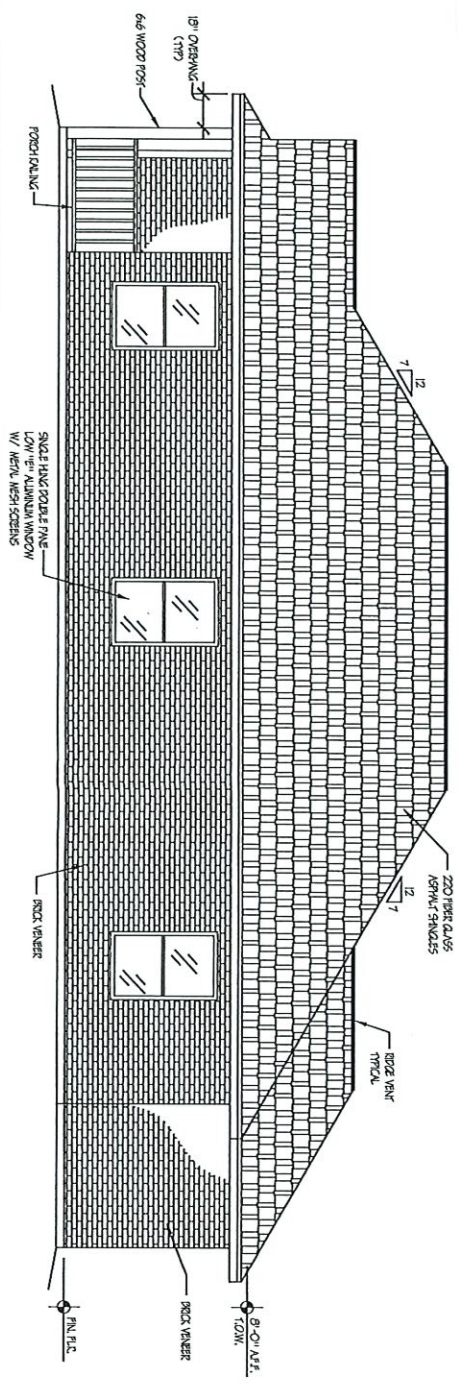

1 LEFT ELEVATION

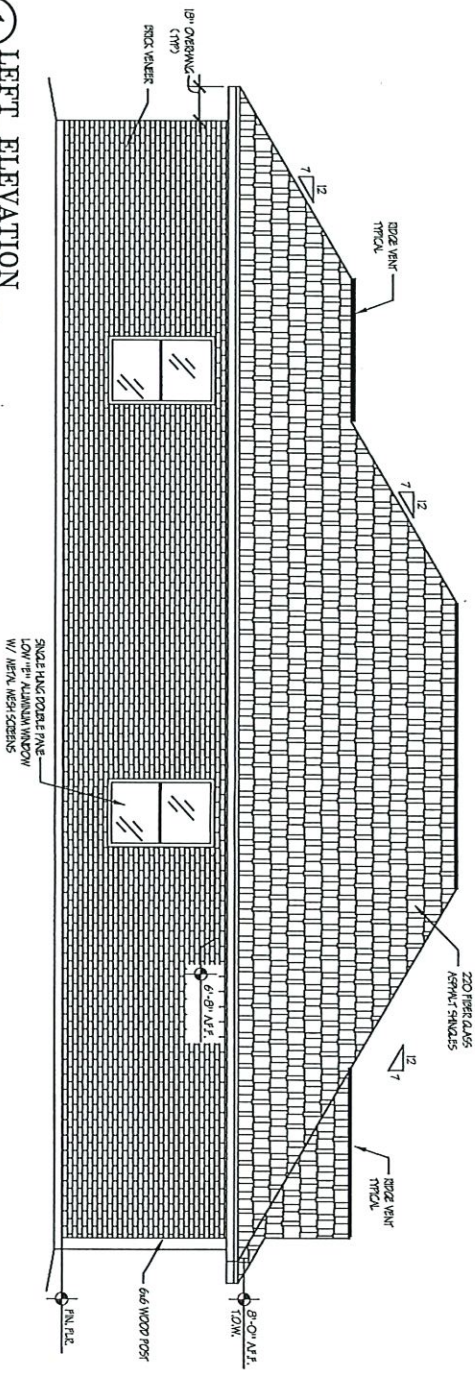

URBAN COUNTY PROGRAM
OWNER OCCUPIED HOUSING REHABILITATION PROGRAM

VICENTE ZAMORA
5414 LEIGH ANN DR. Edinburg Tx. 78542

A1.3

TOTAL AREA
1376 SQ. FT.

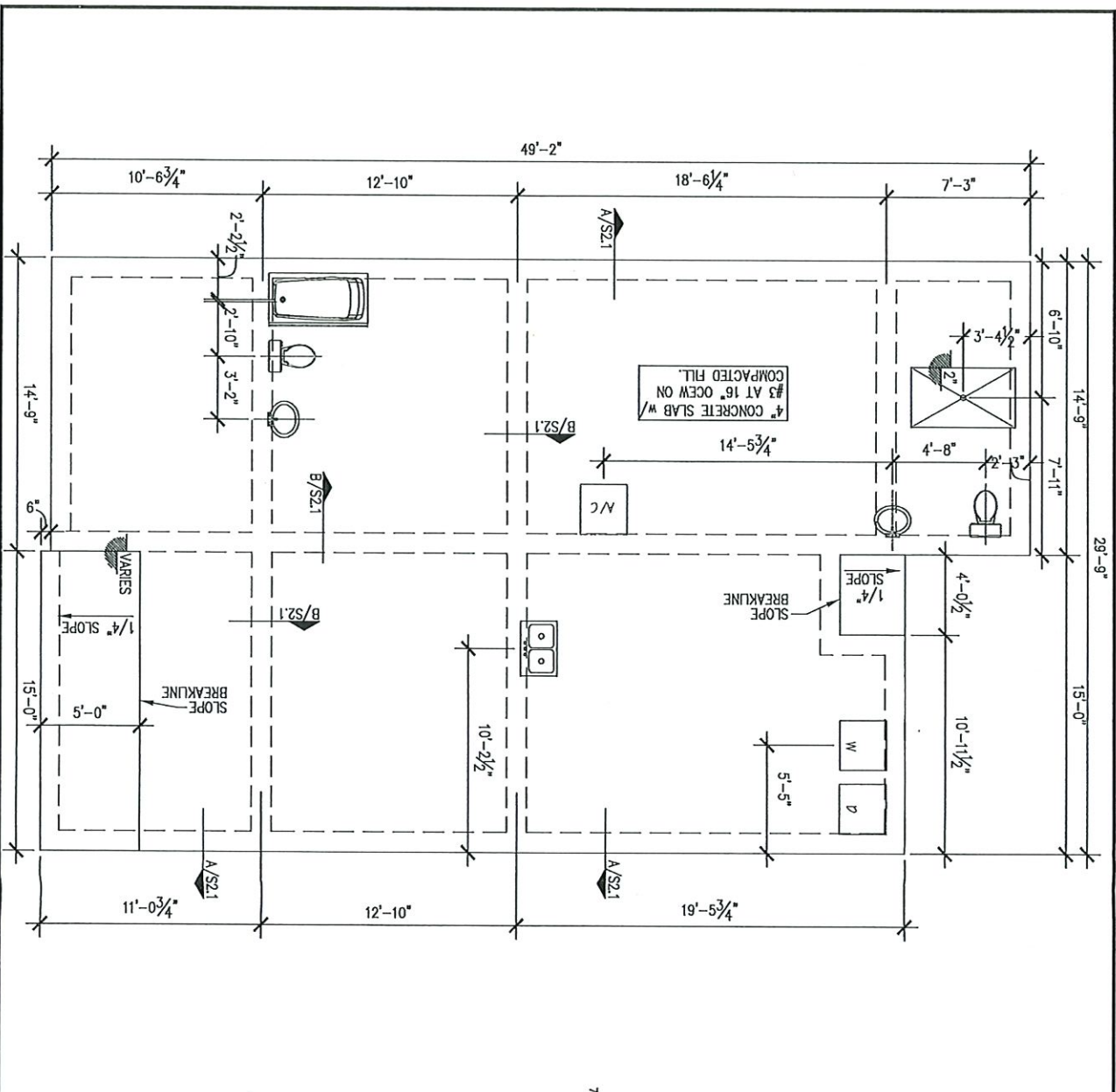

1 FOUNDATION PLAN
3/16" = 1'-0"

NOTES:

- 4" THICK SLAB ON GRADE W/ #3 BARS AT 16" O.C.E.W. AT MID-DEPTH OF SLAB OVER 6 MIL. VISQUEEN OVER APPROVED COMPACTED FILL.
- EXTERIOR GRADE BEAMS TO BE 12"x30" W/ 4-#5 BARS CONT. TOP AND BOTTOM W/ #3 STRIRUPS AT 24" O/C. A MINIMUM OF 6" IN DEPTH TO UNDISTURBED SOIL.
- INTERIOR GRADE BEAMS TO BE 12"x24" W/ 4-#5 BARS CONT. TOP AND BOTTOM W/ #3 STRIRUPS AT 24" O/C. A MINIMUM OF 6" IN DEPTH TO UNDISTURBED SOIL.
- CORNER BARS AT ALL CORNERS AND INTERSECTIONS SHALL BE #5 x 2'-0"x2'-0". APPLY 6x6 WIRE MESH AT SIDEWALKS AND DRIVEWAYS.
- INSTALL ANCHOR BOLTS AT PERIMETER AT 48" O/C.
- USE ONLY COMPACTED SELECT FILL DIRT. FINISH FLOOR TO BE 18" FROM TOP OF CURB, UNLESS OTHERWISE NOTED.

A EXTERIOR BEAM
NTS

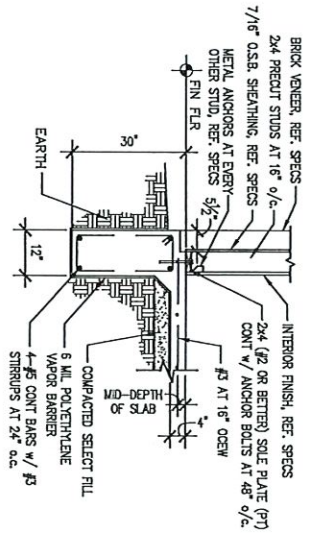

B INTERIOR BEAM
NTS

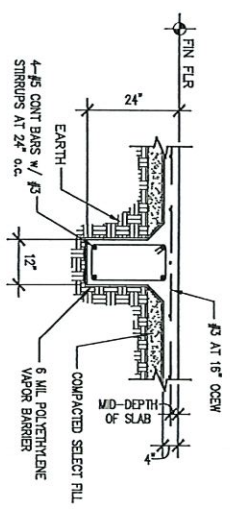

URBAN COUNTY PROGRAM
OWNER OCCUPIED HOUSING REHABILITATION PROGRAM

VICENTE ZAMORA
5414 LEIGH ANN DR. Edinburg Tx. 78542

S2.1

TOTAL AREA
1376 SQ. FT.

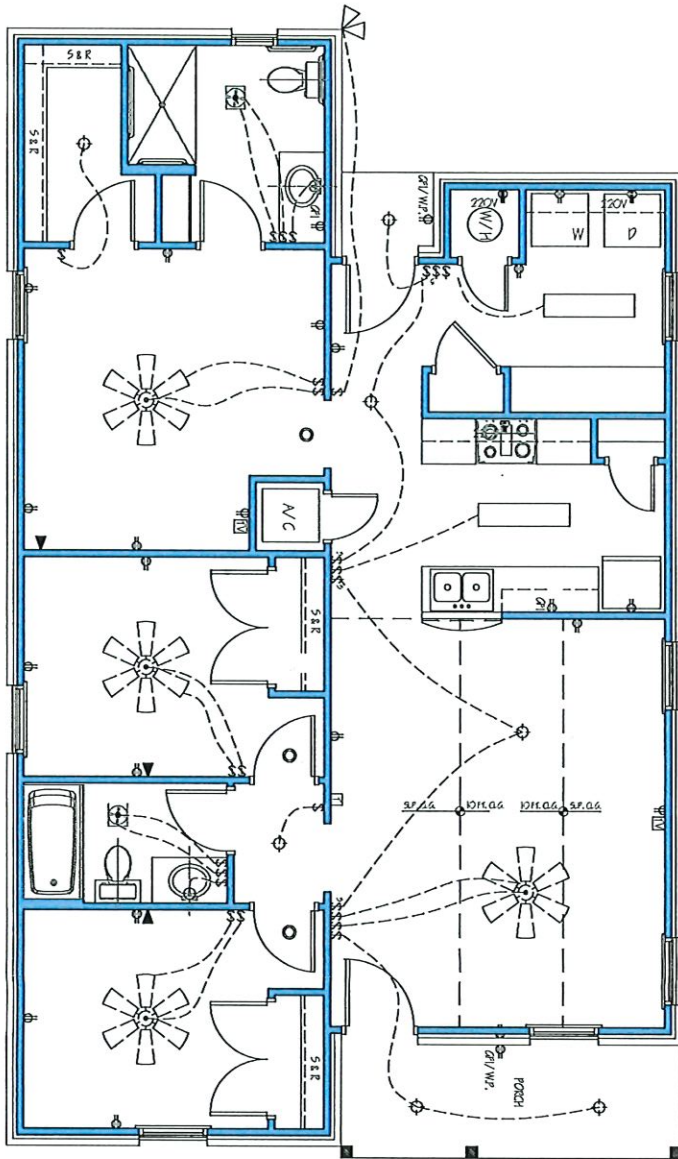

1
 3/16" = 1'-0"
ELECTRICAL PLAN

ELECTRICAL LEGEND

(WH)	WATER HEATER	⊕	LIGHT FIXTURE
⊕	DUPLEX ELECTRICAL RECEPT.	\$	LIGHT SWITCH
⊕	220V. DUPLEX ELECTRICAL RECEPTACLE	⊠	THERMOSTAT
⊕	GROUND FAULT CIRCUIT INTERRUPTER	⊙	SMOKE DETECTOR
⊕	BATHROOM EXHAUST FAN		

ELECTRICAL NOTES:

1. ELECTRICAL TO BE DONE PER 2015 IECC OR CODE ADOPTED BY MUNICIPALITY.
2. ARC FAULT CIRCUIT BREAKERS TO BE INSTALLED IN EVERY BEDROOM.
3. TELEPHONE AND CABLE JACKS INSTALLED IN EVERY BEDROOM.
4. DO NOT INSTALL TEMPORARY POWER IN PANEL BOX LEAVING EXPOSED WIRES.
5. ALL CIRCUITS IN PANEL BOX SHALL BE IDENTIFIED BEFORE FINAL INSPECTION.
6. GFCI PROTECTION SHALL BE INSTALLED IN ALL WET AREAS.
7. BATHROOM VENTILATION SHALL BE EXHAUSTED DIRECTLY TO THE OUTSIDE.
8. SMOKE DETECTORS SHALL BE INTERCONNECTED AND SHALL HAVE A BACKUP BATTERY.
9. SURFACE MOUNT/PENDANT LIGHTING IN CLOSETS SHALL BE 12" MINIMUM AWAY FROM SHELVES.
10. FIXTURES INSTALLED IN SHOWER AREAS SHALL BE SUITABLE FOR WET LOCATIONS.
11. ATTIC SHALL BE PROVIDED WITH LIGHT AND SWITCH.

URBAN COUNTY PROGRAM
 OWNER OCCUPIED HOUSING REHABILITATION PROGRAM

VICENTE ZAMORA
 5414 LEIGH ANN DR. Edinburg Tx. 78542

TOTAL AREA
 1376 SQ. FT.

E1.1

SPECIFICATIONS

ALL SPECIFICATIONS SHALL ASSUME THE USE OF CONTRACTOR'S MINIMUM GENERAL SPECIFICATIONS MANUAL
OWNER (S) VICENTE ZAMORA CASE NO.: DATE: 05/26/2021 ADDRESS: LEIGH ANN DR. EDINBURG, TEXAS. PHONE: 956-328-4159 BY: ERIC GONZALES

1. FOUNDATION WORK:

- BUILD A NEW CONCRETE FOUNDATION TO COMPLY WITH PLANS, SPECS. CITY AND / COUNTY REQUIREMENTS. PROJECTS TO BE 18" ABOVE CENTER LINE OF STREET OR 12" ABOVE NATURAL GROUND, WHICHEVER IS GREATER. PROVIDE CONCRETE SLAB FOR AC UNIT & A MIN. OF 12 X 25 DRIVEWAY (depending on city).

2. PLUMBING GENERAL: (SEE SPECS)

- ALL PLUMBING ROUGH SHALL BE AS FOLLOWS:
 - WATER SUPPLY TO HOUSE SHALL HAVE A 3/4" CUTOFF VALVE BEFORE ENTRY TO HOUSE.
 - INTERIOR WATER SUPPLY LINES FOR HOUSE SHALL BE ALL NEW PEV OR APPROXIMATE DIAMETER
 - NEW PEV PIPES AND FITTINGS.
 - OF 1" MINIMUM DIAMETER FOR ALL EXTERIOR WATER SUPPLY LINES BELOW GROUND.
 - OF APPROPRIATE DIAMETER FOR DWV (DRAIN, WASTE, AND VENTS).
- SEWER CONNECTION SHALL HAVE (1) PLASTIC PVC SEWER CLEAN OUT
- ALL PLUMBING FINISH SHALL BE AS FOLLOWS:
 - RELATED PLUMBING ITEMS:
 - 3/4" EXTERIOR HOSE BRASS BB FAUCETS:
 - PLUMBING SEALANT FOR ALL DRAINS, AND SINK PERIMETERS
 - ALL OTHER RELATED PLUMBING (SEE SPECS)
 - FIXTURES:
 - KITCHEN SINK W/ RELATED PLUMBING & FAUCETS
 - PEDestal SINK W/ RELATED PLUMBING & FAUCETS
 - TOILET OF MATCHING COLOR
 - SHOWER WITH RELATED PLUMBING AND HANDICAP ACCESSIBLE
 - SHOWER FAUCETS & REMOVABLE SHOWER HEAD
 - MEDICINE CABINETS/TOWEL RACKS/ T.P. DISPENSER/ TOOTHBRUSH & SOAP HOLDER, & SHOWER ROD (SEE SPECS)
 - WATER HEATER INSTALLED AS PER SPECS. (GAS OR ELECTRIC AS PER OWNER REQUEST)

3. INTERIOR/EXTERIOR WALLS & CEILING:

- ALL INTERIOR AND EXTERIOR WALL FRAMING:
 - 2x4" (#2 OR BETTER) FOR USE IN: SOLE PLATES (TREATED LUMBER)
 - DOUBLE TOP PLATES
 - 2x5/8" PRE-CUT STUDS @ 16" O.C.
 - WINDOW SILLS
 - CEILING JOIST CHAIN BLOCKING @ 48" O.C.
 - 2x6" (#2 OR BETTER) FOR USE IN: WINDOW & DOOR HEADERS WITH 1"72" SPACER.

4. ROOF: (SLOPE=6/12)

- ROOF SHALL HAVE:
 - A HIPGABLE STYLE ROOF WITH 18" OVERHANGS.
 - A HIPGABLE STYLE FRONT PORCH AS PER PLANS.
 - PORCH COLUMNS MUST BE FASTENED TO CONCRETE.
 - AN ADEQUATE COMBINATION OF RIDGE & SOFFIT VENTS WITH AIR CHUTES.
 - ADEQUATE RAIN GUTTERS WITH DOWN SPOUTS FOR THE ROOF AREA THAT MAY AFFECT OWNERS. SHINGLES TO BE OF LIGHT COLOR (no black shingles)

5. PORCH & CANOPY FLOORS:

- THE HOUSE SHALL HAVE PORCH FLOORS AS FOLLOWS:
 - A FRONT PORCH FLOOR
 - A SIDERACK PORCH FLOOR.

6. INSULATION:

- ALL LIVING AREA CEILING WITH BLOWN IN INSULATION TO AN R-49 FACTOR. (need a combined R-30.8 & R-19 to meet requirement)
- HAVE RULERS INSTALLED FOR EVERY 300 SQUARE FEET BEFORE FRAMING AND ROUGH-IN INSPECTION IS SCHEDULED.
- INSULATION FOLM SHALL BE USED AROUND ALL WINDOWS, WIRES, PLUMBING, ELECTRICAL, 2x4 BOTTOM PLATES, AND ALL PENETRATED AREAS.
- ALL PENETRATED WALLS WITH R-45 F.G. BATT.
- ALL EXTERIOR PIPES EXPOSED TO WEATHER.

7. INTERIOR FINISH:

- ALL TRIM SHALL BE INSTALLED AS PER SPECS
- ALL PAINT SHALL BE APPLIED AS PER SPECS (2-COATS) WITH PAINT COMPARABLE IN QUALITY TO SHEWEN WILLIAMS ALLOW A VARIETY OF DIFFERENT COLORS FOR CLIENT TO CHOOSE FROM. (2 COLOR CHOICE MIN)

8. EXTERIOR FINISH:

- BRICK VENER \$390.00 PER THOUSAND MAXIMUM ALL FINANCES (OWNER TO SELECT COLOR PRE-SELECTED BY PROGRAM SPECIALIST)

9. SIDING:

- THE SIDING SHALL BE 5/8" FIBER CEMENT/ PLANKS WITH ALL CEDAR TRIM TO ENTIRE HOUSE.

10. WINDOWS:

- INSTALL 7/16" O.S.B. AS PER MANUFACTURER'S SPECIFICATIONS. REFERENCE DETAIL.
- SHALL BE NEW LOW-E DOUBLE PANE INSULATED ALUMINUM WINDOWS. SIZE AS PER PLAN. KEEP LABELS ON WINDOWS UNTIL FINAL INSPECTION HAS BEEN CLEARED.

11. CABINETS GENERAL:

- BUILD AND/OR INSTALL NEW KITCHEN CABINETS TO INCLUDE:
 - A RANGE CABINET.
 - A KITCHEN BATHROOM FORMICA COUNTER TOP OF MATCHING COLOR.
 - BUILD AND/OR INSTALL A NEW VANITY CABINET (IF APPLICABLE) FOR BATHROOM WITH FORMICA TO MATCH LAUNDRY SINK AND WALLS. ALL CABINERY PIECES SHOULD BE NEW AND COMPLETE AND BUILT TO PROFESSIONAL STANDARDS.

12. FLOOR, SUBFLOOR, & FINISH FLOORING:

- APPLY VCT FLOOR TILE TO ALL LIVING AREA HOUSE FLOORS.

13. ELECTRICAL GENERAL

- ALL ELECTRICAL INSTALLATIONS & WORK AS PER ELECTRICAL CODE WITH THE FOLLOWING CONDITIONS:
 - PROVIDE RANGE OUTLET AS PER OWNER'S REQUEST.
 - PROVIDE APPROPRIATE WASHER & DRYER CONNECTION.
 - (2) 52" CEILING FANS (CEILING HUGGER STYLE) COMPARABLE IN QUALITY TO THE "HUNTER" BRAND. THE CONTRACTOR SHALL ALLOW 30.00 FOR MATERIAL & LABOR. LOCATION AS PER OWNER REQUEST.
 - INSTALL GFCI OUTLETS IN BATHROOMS, KITCHEN, AND EXTERIOR WALLS.
 - EACH ELECTRICAL PANEL OR BREAKERBOX, LIGHT SWITCH, & THERMOSTAT NO HIGHER THAN 48" ABOVE FLOOR
 - EACH ELECTRICAL PLUG TO BE 15" ABOVE THE FLOOR
 - ANY OUTLETS WITHIN 6" FROM KITCHEN OR BATHROOM SINKS MUST BE GFCI

14. RANGE HOOD:

- INSTALL A RANGE HOOD TO FIT OWNER'S RANGE SIZE (30" OR 36") AND VENT TO EXTERIOR.

15. BATHROOM ACCESSORIES:

- ALL ACCESSORIES & MEDICINE CABINETS AS PER SPECS. INCLUDE CURTAIN ROD & PLASTIC RETAINING DAM TO HELP PREVENT WATER FROM ESCAPING SHOWER. INSTALL PEDESTAL SINK AND CABINET ABOVE TOILET. (ALSO INCLUDE TOILET PAPER TOOTHBRUSH, AND SOAP HOLDER.)

16. ACCESS FOR PHYSICAL DISABILITIES:

- INSTALL ONE CONC. RAAMP AS PER OWNERS REQUEST THAT CONNECTS WITH 12 X 25 DRIVEWAY AND STEPS WITH HANDRAILS
- BATHROOM SHOULD ACCOMMODATE GRAB BARS WHERE INDICATED IN PLANS

17. HEATING & A/C:

-

18. SMOKE DETECTORS:

- INSTALL A SMOKE DETECTOR INSIDE EACH SLEEPING ROOM, OUTSIDE SLEEPING ROOMS, ALL WIRED IN SERIES.

19. GENERAL NOTES.

- CONTRACTOR IS RESPONSIBLE FOR:
 - YOUR BID TO INCLUDE ANY COST RELATED TO REQUIREMENTS FROM CITY. CHANGE ORDERS FOR THIS PARTICULAR PURPOSE WILL NOT BE ACCEPTED OR PROCESSED TO CORRECT THE ABOVE MENTIONED YOUR BID TO INCLUDE ANY COST RELATED TO RES-CHECK & ENERGY COMPLIANCE REQUIREMENTS.
 - THE DEMOLISH AND DISPOSAL EXISTING STRUCTURE ELEVATIONS.
 - PROVIDE 6" OF LANDSCAPE DIRT AROUND THE HOUSE ALONG WITH SUFFICIENT GRASS SEEDS UP TO 10' OF PERIMETER.
 - PROVIDING THE APPROPRIATE ELECTRICAL AND/OR GAS CONNECTIONS FOR RANGE AS PER APPLICANT'S REQUEST AND ACCORDING TO APPLICABLE PLUMBING/ELECTRICAL CODE.
 - PROVIDE PHONE JACKS & CABLE CONNECTIONS IN EVERY BDR & LIVING SPACE. KITCHEN PHONE IF REQUESTED.
 - PROVIDE TERAITE PRE-TREATMENT TO ENTIRE HOUSE. OBTAINING, DISPLAYING, AND SUBMITTING ALL PROPER PERMITS & INSPECTIONS.
 - ALL CONTRACTORS WILL BE RESPONSIBLE FOR ANY ADDITIONAL PLANS, SPECIFICATIONS AND/OR DETAILS THAT ARE REQUIRED BY CITIES OR COUNTY AT THE TIME OF AT-TAINING PERMITS.
 - MINIMUM 12x28 CONC. DRIVEWAY WITH CONNECTING SIDEWALK TO RAAMP FOR HANDICAP APPLICANTS.
 - ALL THE GENERAL INFORMATION CONTAINED WITHIN SECTION 23. GENERAL NOTES OF THE CONTRACTOR'S GENERAL SPECIFICATIONS MANUAL.
 - PROVIDE AND INSTALL PROJECTS SIGNS AT EACH CONSTRUCTION SITE
 - CONTRACTOR IS RESPONSIBLE FOR SUPPLYING PORT A POTTY THROUGHOUT CONSTRUCTION PROCESS (demo to final inspection)
 - SHOWER ENTRANCES TO BE 36" WIDE
 - ALL UPP HOMES MUST COMPLY WITH TEXAS GOVERNMENT CODE §2306.514

THE HOMEOWNER SHALL BE RESPONSIBLE FOR

- REMOVE AND DISPOSE OF ALL DEBRIS ON SITE BEFORE THE BEGINNING OF CONSTRUCTION, INCLUDING BUT NOT LIMITED TO TREES, ABANDONED VEHICLES, OLD LUMBER, ETC.
- MAKING NECESSARY DEPOSITS FOR ANY UTILITIES TO BE CONNECTED TO THE NEW DWELLING.

I HAVE READ AND FULLY AGREE WITH THE WRITUP AND PLANS AS PRESENTED TO ME.

NAME OF APPLICANT: Eric Gonzalez

NAME OF CO-APPLICANT: Vicente Zamora

TIME TABLE

ACTIVITY	DATE(S)
Contract Signing	October 12, 2021
Demolition	October 21, 2021
Construction Start	October 22,, 2021
Anticipated Draws	After 50% construction completion After 100% construction completion 30 days after construction completion
End Construction	January 18, 2022

BUDGET

	Total Cost
Pre-Development	\$ 0.00
Acquisition	\$ 0.00
Demolition/Construction	\$88,537.00
Other Costs:	\$ 0.00
TOTAL PROJECT COSTS	\$88,537.00

EXHIBIT "C"
SPECIAL CONDITIONS

None.

EXHIBT "D"
2 C.F.R. § 200.326 & 2 C.F.R. PART 800,
APPENDIX II

2 C.F.R. § 200.326 & 2 C.F.R. Part 200, Appendix II, Required Contract Clauses for Non-Federal Entity Contracts Under Federal Awards

The United States Office of Management and Budget (OMB) issued in 2 C.F.R. 200: *Uniform Administrative Requirements, Cost Principles and Audit Requirements for Federal Awards* (Uniform Guidance). Subpart D: Post Federal Award Requirements: 2 CFR §§200.317-200.326 of the Uniform Guidance contain provisions applicable to procurements made with federal grant funding.

As a non-Federal entity, the Hidalgo County Drainage District No. 1 ("District") contracts must contain the applicable contract clauses described in Appendix II to the Uniform Guidance (Contract Provisions for non-Federal Entity Contracts Under Federal Awards), which are set forth below. 2 C.F.R. §200.326. If applicable, the following clauses shall supersede any existing, similar clauses stated within the bid document, contract, and/or Terms and Conditions. *The term "Contractor" used herein refers to the proposer, bidder or other entity/individual responding to the applicable procurement packet.*

If applicable, the regulations in 2 CFR, Part 200 and Appendix II to the Uniform Guidance, as it may be amended from time to time, and the contract clauses below, are incorporated by reference as part of this procurement packet and any resulting agreement.

To procure goods and services using funds under a federal grant or contract, specific federal laws, regulations, and requirements may apply in addition to those under state law. The following provisions are required and apply when federal funds are expended by the District for any contract resulting from this procurement process.

1. Remedies.

- a. **Applicability.** This requirement applies to all Federal grant and cooperative agreement programs.
- b. **Standard.** Contracts for more than the simplified acquisition threshold currently set at \$150,000, which is the inflation adjusted amount determined by the Civilian Agency Acquisition Council and the Defense Acquisition Regulations Council (Councils) as authorized by 41 U.S.C. 1908, must address administrative, contractual, or legal remedies in instances where contractors violate or breach contract terms, and provide for such sanctions and penalties as appropriate. See 2 C.F.R. Part 200, Appendix II, ¶ A.
- c. **Statement.** Pursuant to Federal Rule (A) above, when federal funds are expended by the District, the District reserves all rights and privileges under the applicable laws and regulations with respect to this procurement in the event of breach of contract by either party. Contractor shall comply with all applicable Federal, State of Texas, and local laws, rules, and regulations and shall obtain all applicable licenses and permits for the conduct of its business and the performance of the services, and any provision of equipment and material ("Applicable Law"). All transactions related to any of the Contract Documents shall be governed by the laws of the State of Texas, and trial of any action brought in connection with the bid or the Contract Documents shall be held exclusively in a state court in the County of Hidalgo, Texas.

2. Termination for Cause and Convenience.

- a. **Applicability.** This requirement applies to all Federal grant and cooperative agreement programs.
- b. **Standard.** All contracts in excess of \$10,000 shall address termination for cause and for convenience by the non-Federal entity including the manner by which it will be effected and the basis for settlement as follows. See 2 C.F.R. Part 200, Appendix II, ¶ B.

c. Statement. Termination. District may terminate this Agreement for any reason upon ten (10) days written notice to the other party. District may terminate this Agreement immediately upon written notice if Contractor breaches this Agreement. In the event of any termination, Contractor shall promptly deliver to the District any and all Work Materials prepared for the District prior to the effective date of such termination, all of which shall become District's sole property. After receipt of the Work Materials, District will pay Contractor for the services which the District determines were satisfactorily performed as of the effective date of the termination.

Excuses for Non-Performance. Either party shall be absolved from its obligations under this contract when and to the extent that performance is delayed or prevented (and in the District's case when and to the extent that its need for the articles, materials or work to be supplied hereunder is reduced or eliminated) by reason of acts of God, fire explosion, war riots, strikes, labor disputes, or governmental laws, orders or regulations.

Default. If Contractor or Subcontractor shall breach any provision hereof or shall become insolvent, enter voluntary or involuntary bankruptcy or receivership proceedings or make an assignment to the benefit of creditors, District shall have the right (without limiting any other rights or remedies which it may have hereunder or by operation of law) to terminate this contract by written notice to Contractor whereupon District shall be relieved of all further obligation hereunder except the obligation to pay the reasonable value of Contractor's prior performance (at not exceeding the contract rate), and Contractor shall be liable to District for all costs incurred by District in completing or procuring the completion of performance in excess of the contract price herein specified. The District's right to require strict performance of any obligation hereunder shall not be affected by any previous waiver, forbearance of course of dealing. Time is of the essence thereof.

3. Equal Employment Opportunity.

a. Applicability: This requirement applies to all Federal grant and cooperative agreement programs.

b. Standard. Except as otherwise provided under 41 C.F.R. Part 60, all contracts that meet the definition of "federally assisted construction contract" in 41 C.F.R. § 60-1.3 must include the equal opportunity clause provided under 41 C.F.R. § 60- 1.4(b), in accordance with Executive Order 11246, *Equal Employment Opportunity* (30 Fed. Reg. 12319, 12935, 3 C.F.R. Part, 1964- 1965 Comp., p. 339), as amended by Executive Order 11375, *Amending Executive Order 11246 Relating to Equal Employment Opportunity*, and implementing regulations at 41 C.F.R. Part 60 (Office of Federal Contract Compliance Programs, Equal Employment Opportunity, Department of Labor). See 2 C.F.R. Part 200, Appendix II, ¶ C.

c. Key Definitions:

(1) *Federally Assisted Construction Contract.* The regulation at 41 C.F.R. § 60-1.3 defines a "federally assisted construction contract" as any agreement or modification thereof between any applicant and a person for construction work which is paid for in whole or in part with funds obtained from the Government or borrowed on the credit of the Government pursuant to any Federal program involving a grant, contract, loan, insurance, or guarantee, or undertaken pursuant to any Federal program involving such grant, contract, loan, insurance, or guarantee, or any application or modification thereof approved by the Government for a grant, contract, loan, insurance, or guarantee under which the applicant itself participates in the construction work.

(2) *Construction Work.* The regulation at 41 C.F.R. § 60-1.3 defines "construction work" as the construction, rehabilitation, alteration, conversion, extension, demolition or repair of buildings, highways, or other changes or improvements to real property, including facilities providing

*Con
stru
ctio
n
Loa
n
Agr
ee
me
nt
2C.
F.R.
200*

utility services. The term also includes the supervision, inspection, and other onsite functions incidental to the actual construction

- d. Statement: Contractor will comply with the Nondiscrimination Civil Rights Act of 1964, as amended and all Federal regulations relative to nondiscrimination in Federally assisted programs. The regulation at 41 C.F.R. Part 60-1.4(b) requires the insertion of the following contract clause:

"During the performance of this contract, the contractor agrees as follows:

- (1) The contractor will not discriminate against any employee or applicant for employment because of race, color, religion, sex, or national origin. The contractor will take affirmative action to ensure that applicants are employed, and that employees are treated during employment without regard to their race, color, religion, sex, or national origin. Such action shall include, but not be limited to the following: Employment, upgrading, demotion, or transfer; recruitment or recruitment advertising; layoff or termination; rates of pay or other forms of compensation; and selection for training, including apprenticeship. The contractor agrees to post in conspicuous places, available to employees and applicants for employment, notices to be provided setting forth the provisions of this nondiscrimination clause.
- (2) The contractor will, in all solicitations or advertisements for employees placed by or on behalf of the contractor, state that all qualified applicants will receive considerations for employment without regard to race, color, religion, sex, or national origin.
- (3) The contractor will send to each labor union or representative of workers with which he has a collective bargaining agreement or other contract or understanding, a notice to be provided advising the said labor union or workers' representatives of the contractor's commitments under this section, and shall post copies of the notice in conspicuous places available to employees and applicants for employment.
- (4) The contractor will comply with all provisions of Executive Order 11246 of September 24, 1965, and of the rules, regulations, and relevant orders of the Secretary of Labor.
- (5) The contractor will furnish all information and reports required by Executive Order 11246 of September 24, 1965, and by rules, regulations, and orders of the Secretary of Labor, or pursuant thereto, and will permit access to his books, records, and accounts by the administering agency and the Secretary of Labor for purposes of investigation to ascertain compliance with such rules, regulations, and orders.
- (6) In the event of the contractor's noncompliance with the nondiscrimination clauses of this contract or with any of the said rules, regulations, or orders, this contract may be canceled, terminated, or suspended in whole or in part and the contractor may be declared ineligible for further Government contracts or federally assisted construction contracts in accordance with procedures authorized in Executive Order 11246 of September 24, 1965, and such other sanctions as may be imposed and remedies invoked as provided in Executive Order 11246 of September 24, 1965, or by rule, regulation, or order of the Secretary of Labor, or as otherwise provided by law.
- (7) The contractor will include the portion of the sentence immediately preceding paragraph (1) and the provisions of paragraphs (1) through (7) in every subcontract or purchase order unless exempted by rules, regulations, or orders of the Secretary of Labor issued pursuant to section 204 of Executive Order 11246 of September 24, 1965, so that such provisions will be binding upon each subcontractor or vendor. The contractor will take such action with respect to any

subcontract or purchase order as the administering agency may direct as a means of enforcing such provisions, including sanctions for noncompliance: Provided, however, That in the event a contractor becomes involved in, or is threatened with, litigation with a subcontractor or vendor as a result of such direction by the administering agency the contractor may request the United States to enter into such litigation to protect the interests of the United States.”

4. Davis Bacon Act and Copeland Anti-Kickback Act.

- a. Applicability of Davis-Bacon Act. The Davis-Bacon Act only applies to the emergency Management Preparedness Grant Program, Homeland Security Grant Program, Nonprofit Security Grant Program, Tribal Homeland Security Grant Program, Port Security Grant Program, and Transit Security Grant Program. **It does not apply to other Federal grant and cooperative agreement programs, including the Public Assistance Program.**
- b. Standard. All prime construction contracts in excess of \$2,000 awarded by non-Federal entities must include a provision for compliance with the Davis-Bacon Act (40 U.S.C. §§ 3141-3144 and 3146-3148) as supplemented by Department of Labor regulations at 29 C.F.R. Part 5 (Labor Standards Provisions Applicable to Contracts Covering Federally Financed and Assisted Construction)). See 2 C.F.R. Part 200, Appendix II, ¶ D.

In accordance with the statute, contractors must be required to pay wages to laborers and mechanics at a rate not less than the prevailing wages specified in a wage determination made by the Secretary of Labor. In addition, contractors must be required to pay wages not less than once a week.

The non-Federal entity must place a copy of the current prevailing wage determination issued by the Department of Labor in each solicitation. The decision to award a contract or subcontract must be conditioned upon the acceptance of the wage determination. The non-Federal entity must report all suspected or reported violations to the Federal awarding City.

In contracts subject to the Davis-Bacon Act, the contracts must also include a provision for compliance with the Copeland “Anti-Kickback” Act (40 U.S.C. § 3145), as supplemented by Department of Labor regulations at 29 C.F.R. Part 3 (Contractors and Subcontractors on Public Building or Public Work Financed in Whole or in Part by Loans or Grants from the United States). The Copeland Anti-Kickback Act provides that each contractor or subrecipient must be prohibited from inducing, by any means, any person employed in the construction, completion, or repair of public work, to give up any part of the compensation to which he or she is otherwise entitled. The non-Federal entity must report all suspected or reported violations to FEMA or applicable Federal entity.

- c. Statement. The regulation at 29 C.F.R. § 5.5(a) does provide the required contract clause that applies to compliance with both the Davis-Bacon and Copeland Acts. However, as discussed in the previous subsection, the Davis-Bacon Act does not apply to Public Assistance recipients and subrecipients. In situations where the Davis-Bacon Act does not apply, neither does the Copeland “Anti-Kickback Act.” However, for purposes of grant programs where both clauses do apply, FEMA or applicable Federal entity requires the following contract clause:

“Compliance with the Copeland “Anti-Kickback” Act.

- (1) *Contractor.* The contractor shall comply with 18 U.S.C. § 874, 40 U.S.C. § 3145, and the requirements of 29 C.F.R. pt. 3 as may be applicable, which are incorporated by reference into this contract.

(2) *Subcontracts.* The contractor or subcontractor shall insert in any subcontracts the clause above and such other clauses as Federal requirements may by appropriate instructions require, and also a clause requiring the subcontractors to include these clauses in any lower tier subcontracts. The prime contractor shall be responsible for the compliance by any subcontractor or lower tier subcontractor with all of these contract clauses.

(3) *Breach.* A breach of the contract clauses above may be grounds for termination of the contract, and for debarment as a contractor and subcontractor as provided in 29 C.F.R. § 5.12.”

5. Contract Work Hours and Safety Standards Act.

a. Applicability. This requirement applies to all Federal grant and cooperative agreement programs.

b. Standard. Where applicable (see 40 U.S.C. § 3701), all contracts awarded by the non-Federal entity in excess of \$100,000 that involve the employment of mechanics or laborers must include a provision for compliance with 40 U.S.C. §§ 3702 and 3704, as supplemented by Department of Labor regulations at 29 C.F.R. Part 5. See 2 C.F.R. Part 200, Appendix II, ¶ E.

Under 40 U.S.C. § 3702, each contractor must be required to compute the wages of every mechanic and laborer on the basis of a standard work week of 40 hours. Work in excess of the standard work week is permissible provided that the worker is compensated at a rate of not less than one and a half times the basic rate of pay for all hours worked in excess of 40 hours in the work week.

The requirements of 40 U.S.C. § 3704 are applicable to construction work and provide that no laborer or mechanic must be required to work in surroundings or under working conditions which are unsanitary, hazardous or dangerous. These requirements do not apply to the purchases of supplies or materials or articles ordinarily available on the open market, or contracts for transportation or transmission of intelligence.

The regulation at 29 C.F.R. § 5.5(b) provides the required contract clause concerning compliance with the Contract Work Hours and Safety Standards Act:

c. Statement

“Compliance with the Contract Work Hours and Safety Standards Act.

(1) *Overtime requirements.* No contractor or subcontractor contracting for any part of the contract work which may require or involve the employment of laborers or mechanics shall require or permit any such laborer or mechanic in any workweek in which he or she is employed on such work to work in excess of forty hours in such workweek unless such laborer or mechanic receives compensation at a rate not less than one and one-half times the basic rate of pay for all hours worked in excess of forty hours in such workweek.

(2) *Violation; liability for unpaid wages; liquidated damages.* In the event of any violation of the clause set forth in paragraph (1) of this section the contractor and any subcontractor responsible therefor shall be liable for the unpaid wages. In addition, such contractor and subcontractor shall be liable to the United States (in the case of work done under contract for the District of Columbia or a territory, to such District or to such territory), for liquidated damages. Such liquidated damages shall be computed with respect to each individual laborer or mechanic, including watchmen and guards, employed in violation of the clause set forth in paragraph (1) of this section, in the sum of \$10 for each calendar day on which such individual was required or permitted to work in excess of the standard workweek of forty hours without payment of the overtime wages required by the clause set forth in paragraph (1) of this section.

- (3) *Withholding for unpaid wages and liquidated damages.* The District shall upon its own action or upon written request of an authorized representative of the Department of Labor withhold or cause to be withheld, from any moneys payable on account of work performed by the contractor or subcontractor under any such contract or any other Federal contract with the same prime contractor, or any other federally-assisted contract subject to the Contract Work Hours and Safety Standards Act, which is held by the same prime contractor, such sums as may be determined to be necessary to satisfy any liabilities of such contractor or subcontractor for unpaid wages and liquidated damages as provided in the clause set forth in paragraph (2) of this section.
- (4) *Subcontracts.* The contractor or subcontractor shall insert in any subcontracts the clauses set forth in paragraph (1) through (4) of this section and also a clause requiring the subcontractors to include these clauses in any lower tier subcontracts. The prime contractor shall be responsible for compliance by any subcontractor or lower tier subcontractor with the clauses set forth in paragraphs (1) through (4) of this section.”

6. Rights to Inventions Made Under a Contract or Agreement.

- a. Applicability: Stafford Act Disaster Grants. This requirement **does not apply to the Public Assistance, Hazard Mitigation Grant Program, Fire Management Assistance Grant Program, Crisis Counseling Assistance and Training Grant Program, Disaster Case Management Grant Program, and Federal Assistance to Individuals and Households – Other Needs Assistance Grant Program, as FEMA or Federal awards under these programs do not meet the definition of “funding agreement.”**
- b. Standard. If the FEMA or Federal award meets the definition of “funding agreement” under 37 C.F.R. § 401.2(a) and the non-Federal entity wishes to enter into a contract with a small business firm or nonprofit organization regarding the substitution of parties, assignment or performance of experimental, developmental, or research work under that “funding agreement,” the non-Federal entity must comply with the requirements of 37 C.F.R. Part 401 (Rights to Inventions Made by Nonprofit Organizations and Small Business Firms Under Government Grants, Contracts and Cooperative Agreements), and any implementing regulations issued by FEMA or applicable awarding agency. See 2 C.F.R. Part 200, Appendix II, ¶ F.
- c. Key Definition: The regulation at 37 C.F.R. § 401.2(a) currently defines “funding agreement” as any contract, grant, or cooperative agreement entered into between any Federal agency, other than the Tennessee Valley Authority, and any contractor for the performance of experimental, developmental, or research work funded in whole or in part by the Federal government. This term also includes any assignment, substitution of parties, or subcontract of any type entered into for the performance of experimental, developmental, or research work under a funding agreement as defined in the first sentence of this paragraph.

7. Clean Air Act and the Federal Water Pollution Control Act.

- a. Applicability and Standard: Contracts of amounts in excess of \$150,000 must contain a provision that requires the contractor to agree to comply with all applicable standards, orders, or regulations issued pursuant to the Clean Air Act (42 U.S.C. §§ 7401-7671q) and the Federal Water Pollution Control Act as amended (33 U.S.C. §§ 1251-1387). Violations must be reported to the Federal awarding agency and the Regional Office of the Environmental Protection Agency. See 2 C.F.R. Part 200, Appendix II, ¶ G.
- b. Statement: Included in contracts as provided in section “7a” above.

- (1) The contractor agrees to comply with all applicable standards, orders or regulations issued pursuant to the Clean Air Act, as amended, 42 U.S.C. § 7401 et seq. and the Federal Water Pollution Control Act, as amended, 33 U.S.C. 1251 et seq.
- (2) The contractor agrees to report each violation to the Federal awarding agency (e.g. Federal Emergency Management Agency-FEMA) and the Regional Office of the Environmental Protection Agency. Contractor understands and agrees that each violation reported to the District will, in turn, be reported as required to assure notification to the Federal awarding agency and the appropriate Environmental Protection Agency Regional Office.
- (3) The contractor agrees to include these requirements in each subcontract exceeding \$150,000 financed in whole or in part with Federal assistance provided by the applicable Federal awarding agency (e.g. FEMA).

8. Debarment and Suspension.

- a. **Applicability:** This requirement applies to all Federal grant and cooperative agreement programs.
- b. **Standard.** Non-Federal entities and contractors are subject to the debarment and suspension regulations implementing Executive Order 12549, *Debarment and Suspension* (1986) and Executive Order 12689, *Debarment and Suspension* (1989) at 2 C.F.R. Part 180 and the Department of Homeland Security's regulations at 2 C.F.R. Part 3000 (Nonprocurement Debarment and Suspension).

These regulations restrict awards, subawards, and contracts with certain parties that are debarred, suspended, or otherwise excluded from or ineligible for participation in Federal assistance programs and activities. See 2 C.F.R. Part 200, Appendix II, ¶ H; and Chapter IV, ¶ 6.d and Appendix C, ¶ 2. A contract award must not be made to parties listed in the SAM Exclusions. SAM Exclusions is the list maintained by the General Services Administration that contains the names of parties debarred, suspended, or otherwise excluded by agencies, as well as parties declared ineligible under statutory or regulatory authority other than Executive Order 12549. SAM exclusions can be accessed at www.sam.gov. See 2 C.F.R. § 180.530; Chapter IV, ¶ 6.d and Appendix C, ¶ 2.

In general, an "excluded" party cannot receive a Federal grant award or a contract within the meaning of a "covered transaction," to include subawards and subcontracts. This includes parties that receive Federal funding indirectly, such as contractors to recipients and subrecipients. The key to the exclusion is whether there is a "covered transaction," which is any nonprocurement transaction (unless excepted) at either a "primary" or "secondary" tier. Although "covered transactions" do not include contracts awarded by the Federal Government for purposes of the nonprocurement common rule and DHS's implementing regulations, it does include some contracts awarded by recipients and subrecipient.

Specifically, a covered transaction includes the following contracts for goods or services:

- (1) The contract is awarded by a recipient or subrecipient in the amount of at least \$25,000.
 - (2) The contract requires the approval of FEMA or applicable Federal entity, regardless of amount.
 - (3) The contract is for Federally-required audit services.
 - (4) A subcontract is also a covered transaction if it is awarded by the contractor of a recipient or subrecipient and requires either the approval of FEMA or applicable Federal entity or is in excess of \$25,000.
- c. **Statement.** The following provides a debarment and suspension clause. It incorporates a method of verifying that contractors are not excluded or disqualified:

For maximum protection, provide a print or electronic document for every prime and subcontractor, from www.sam.gov in order to ensure that they are not debarred, suspended, or otherwise excluded from or ineligible for participation in Federal assistance programs and activities.

This contract is a covered transaction for purposes of 2 C.F.R. pt. 180 and 2 C.F.R. pt. 3000. As such the contractor is required to verify that none of the contractor, its principals (defined at 2 C.F.R. § 180.995), or its affiliates (defined at 2 C.F.R. § 180.905) are excluded (defined at 2 C.F.R. 180.940) or disqualified (defined at 2 C.F.R. § 180.935).

The contractor must comply with 2 C.F.R. pt. 180, subpart C and 2 C.F.R. pt. 3000, subpart C and must include a requirement to comply with these regulations in any lower tier covered transaction it enters into.

This certification is a material representation of fact relied upon by (insert name of subrecipient). If it is later determined that the contractor did not comply with 2 C.F.R. pt. 180, subpart C and 2 C.F.R. pt. 3000, subpart C, in addition to remedies available to (name of state agency serving as recipient and name of subrecipient), the Federal Government may pursue available remedies, including but not limited to suspension and/or debarment.

The bidder or proposer agrees to comply with the requirements of 2 C.F.R. pt. 180, subpart C and 2 C.F.R. pt. 3000, subpart C while this offer is valid and throughout the period of any contract that may arise from this offer. The bidder or proposer further agrees to include a provision requiring such compliance in its lower tier covered transactions.”

9. Byrd Anti-Lobbying Amendment.

- a. Applicability: This requirement applies to all Federal grant and cooperative agreement programs.
- b. Standard. Contractors that apply or bid for an award of \$100,000 or more must file the required certification. See 2 C.F.R. Part 200, Appendix II, ¶ I; 44 C.F.R. Part 18; Chapter IV, 6.c; Appendix C, ¶ 4. Each tier certifies to the tier above that it will not and has not used Federal appropriated funds to pay any person or organization for influencing or attempting to influence an officer or employee of any City, a member of Congress, officer or employee of Congress, or an employee of a member of Congress in connection with obtaining any Federal contract, grant or any other award covered by 31 U.S.C. § 1352. Each tier must also disclose any lobbying with non-Federal funds that takes place in connection with obtaining any Federal award. Such disclosures are forwarded from tier to tier up to the non-Federal award. See Chapter IV, ¶ 6.c and Appendix C, ¶ 4.
- c. Statement. The following statement in bold provides a Byrd Anti-Lobbying contract clause:

(IF APPLICABLE, PLEASE FILL IN BLANKS AND SIGN)

“Byrd Anti-Lobbying Amendment, 31 U.S.C. § 1352 (as amended)

Contractors who apply or bid for an award of \$100,000 or more shall file the required certification. Each tier certifies to the tier above that it will not and has not used Federal appropriated funds to pay any person or organization for influencing or attempting to influence an officer or employee of any agency, a member of Congress, officer or employee of Congress, or an employee of a member of Congress in connection with obtaining any Federal contract, grant, or any other award covered by 31 U.S.C. § 1352. Each tier shall also disclose any lobbying with non-Federal funds that takes place in connection with obtaining any Federal award. Such disclosures are forwarded from tier to tier up to the recipient.”

APPENDIX A, 44 C.F.R. PART 18 – CERTIFICATION REGARDING LOBBYING

Certification for Contracts, Grants, Loans, and Cooperative Agreements

(To be submitted with each bid or offer exceeding \$100,000)

The undersigned Contractor, _____
certifies, to the best of his or her knowledge, that:

1. No Federal appropriated funds have been paid or will be paid, by or on behalf of the undersigned, to any person for influencing or attempting to influence an officer or employee of an agency, a Member of Congress, an officer or employee of Congress, or an employee of a Member of Congress in connection with the awarding of any Federal contract, the making of any Federal grant, the making of any Federal loan, the entering into of any cooperative agreement, and the extension, continuation, renewal, amendment, or modification of any Federal contract, grant, loan, or cooperative agreement.
2. If any funds other than Federal appropriated funds have been paid or will be paid to any person for influencing or attempting to influence an officer or employee of any agency, a Member of Congress, an officer or employee of Congress, or an employee of a Member of Congress in connection with this Federal contract, grant, loan, or cooperative agreement, the undersigned shall complete and submit Standard Form- LLL, "Disclosure Form to Report Lobbying," in accordance with its instructions.
3. The undersigned shall require that the language of this certification be included in the award documents for all subawards at all tiers (including subcontracts, subgrants, and contracts under grants, loans, and cooperative agreements) and that all subrecipients shall certify and disclose accordingly.

This certification is a material representation of fact upon which reliance was placed when this transaction was made or entered into. Submission of this certification is a prerequisite for making or entering into this transaction imposed by 31, U.S.C. § 1352 (as amended by the Lobbying Disclosure Act of 1995). Any person who fails to file the required certification shall be subject to a civil penalty of not less than \$10,000 and not more than \$100,000 for each such failure.

The Contractor, _____, certifies or affirms the truthfulness and accuracy of each statement of its certification and disclosure, if any. In addition, the Contractor understands and agrees that the provisions of 31 U.S.C. § 3801 *et seq.*, apply to this certification and disclosure, if any.

Signature of Contractor's Authorized Official

Name and Title of Contractor's Authorized Official

Date"

10. **Procurement of Recovered Materials.**

- a. **Applicability:** This requirement applies to all Federal grant and cooperative agreement programs.
- b. **Standard.** A non-Federal entity that is a **state agency or agency of a political subdivision** of a state and its contractors must comply with Section 6002 of the Solid Waste Disposal Act, Pub. L. No. 89-272 (1965) (codified as amended by the Resource Conservation and Recovery Act at 42 U.S.C. § 6962). See 2 C.F.R. Part 200, Appendix II, ¶ J; 2 C.F.R. § 200.322; *PDAT Supplement*, Chapter V, ¶ 7.

The requirements of Section 6002 include procuring only items designated in guidelines of the EPA at 40 C.F.R. Part 247 that contain the highest percentage of recovered materials practicable, consistent with maintaining a satisfactory level of competition, where the purchase price of the item exceeds \$10,000 or the value of the quantity acquired by the preceding fiscal year exceeded \$10,000; procuring solid waste management services in a manner that maximizes energy and resource recovery; and establishing an affirmative procurement program for procurement of recovered materials identified in the EPA guidelines.

- c. **Statement.** The following provides the clause that a state agency or agency of a political subdivision of a state and its contractors can include in contracts meeting the above contract thresholds:

“(1) In the performance of this contract, the Contractor shall make maximum use of products containing recovered materials that are EPA- designated items unless the product cannot be acquired—

- (i) Competitively within a timeframe providing for compliance with the contract performance schedule;
- (ii) Meeting contract performance requirements; or
- (iii) At a reasonable price.

(2) Information about this requirement, along with the list of EPA-designate items, is available at EPA’s Comprehensive Procurement Guidelines web site, <https://www.epa.gov/smm/comprehensive-procurement-guideline-cpg-program>.”

Additional Required Contract Clauses for Non-Federal Entity Contracts Under Federal Awards with the Federal Emergency Management Agency (FEMA)

Additional FEMA or applicable Federal Requirements. In addition to the requirements above, non-Federal entity contracts under Federal award subject to financial assistance from FEMA are required to contain the following additional contract clauses. The Uniform Guidance authorizes FEMA to require additional provisions for non-Federal entity contracts. FEMA, pursuant to this authority, requires or recommends the following:

These clauses are incorporated by reference as part of this procurement packet and any resulting agreement.

11. **Changes.**

- a. **Standard.** To be eligible for FEMA assistance under the non-Federal entity’s Federal grant or cooperative agreement, the cost of the change, modification, change order, or constructive change must be allowable, allocable, within the scope of its grant or cooperative agreement, and reasonable for the completion of project scope. FEMA or applicable Federal entity recommends, therefore, that a non-Federal entity include a changes clause in its contract that describes how, if at all,

changes can be made by either party to alter the method, price, or schedule of the work without breaching the contract. The language of the clause may differ depending on the nature of the contract and the end-item procured.

b. Statement. The following provides a contract clause regarding access to records:

“The contractor shall secure written authorization before proceeding with any additional work, whether requested by the District or required to complete the contract. The cost for any changes to the contract price, whether requested by the District or the Contractor will be approved only after submitting the contractor’s true costs for the work and related equipment costs and site expenses.”

12. Access to Records.

a. Standard. All non-Federal entities must place into their contracts a provision that all contractors and their successors, transferees, assignees, and subcontractors acknowledge and agree to comply with applicable provisions governing Department and FEMA or applicable Federal entity access to records, accounts, documents, information, facilities, and staff. See DHS Standard Terms and Conditions, v 3.0, ¶ XXVI (2013).

b. Statement. The following provides a contract clause regarding access to records: “Access to Records. The following access to records requirements apply to this contract:

- (1) The contractor agrees to provide the District, the FEMA or applicable Federal Administrator, the Comptroller General of the United States, or any of their authorized representatives access to any books, documents, papers, and records of the Contractor which are directly pertinent to this contract for the purposes of making audits, examinations, excerpts, and transcriptions.
- (2) The Contractor agrees to permit any of the foregoing parties to reproduce by any means whatsoever or to copy excerpts and transcriptions as reasonably needed.
- (3) The contractor agrees to provide the FEMA or applicable Federal Administrator or his authorized representatives access to construction or other work sites pertaining to the work being completed under the contract.”

13. DHS Seal, Logo, and Flags.

a. Standard. All non-Federal entities must place in their contracts a provision that a contractor shall not use the DHS seal(s), logos, crests, or reproductions of flags or likenesses of DHS City officials without specific FEMA or applicable Federal entity pre-approval. See DHS Standard Terms and Conditions, v3.0, ¶ XXV (2013).

b. Statement. The following provides a contract clause regarding DHS Seal, Logo, and Flags:

“The contractor shall not use the DHS seal(s), logos, crests, or reproductions of flags or likenesses of DHS City officials without specific FEMA or applicable Federal entity pre- approval.”

14. Compliance with Federal Law, Regulations, and Executive Orders.

a. Standard. All non-Federal entities must place into their contracts an acknowledgement that FEMA or applicable Federal financial assistance will be used to fund the contract along with the requirement that the contractor will comply with all applicable Federal law, regulations, executive orders, and FEMA or applicable Federal policies, procedures, and directives.

- b. Statement. The following provides a contract clause regarding Compliance with Federal Law, Regulations and Executive Orders:

“This is an acknowledgement that Federal financial assistance will be used to fund the contract only. The contractor will comply with all applicable Federal law, regulations, executive orders, FEMA or applicable Federal policies, procedures, and directives.”

15. No Obligation by Federal Government.

- a. Standard. The non-Federal entity must include a provision in its contract that states that the Federal Government is not a party to the contract and is not subject to any obligations or liabilities to the non-Federal entity, contractor, or any other party pertaining to any matter resulting from the contract.

- b. Statement. The following provides a contract clause regarding no obligation by the Federal Government:

“The Federal Government is not a party to this contract and is not subject to any obligations or liabilities to the non-Federal entity, contractor, or any other party pertaining to any matter resulting from the contract.”

16. Program Fraud and False or Fraudulent Statements or Related Acts.

- a. Standard. The non-Federal entity must include a provision in its contract that the contractor acknowledges that 31 U.S.C. Chap. 38 (Administrative Remedies for False Claims and Statements) applies to its actions pertaining to the contract.

- b. Statement. The following provides a contract clause regarding Fraud and False or Fraudulent Related Acts:

“The contractor acknowledges that 31 U.S.C. Chap. 38 (Administrative Remedies for False Claims and Statements) applies to the contractor’s actions pertaining to this contract.”

Contractor agrees to comply with all federal, state and local laws, rules, regulations and ordinances, as applicable. It is further acknowledged that the Contractor read and understands all provisions, laws, acts, regulations, etc. as specifically noted above and certifies compliance with the same.

Vendor’s Name/Company Name: **8/A Builders, LLC** _____

Printed Name and Title of Authorized Representative: **Arnoldo Ochoa**

Signature of Authorized Representative: _____ Date: _____