



HIDALGO COUNTY PLANNING DEPARTMENT

T.J. Arredondo
Director of Planning

2818 S. BUSINESS HWY 281
EDINBURG TEXAS 78539
Tel. 956-318-2840 Fax. 956-318-2844

HIDALGO COUNTY COMMISSIONERS COURT MEETING

DATE: 3-07-2023

PROPOSED SIENNA RIDGE SUBDIVISION PRECINCT No. 1.

ENGINEER NAIN ENGINEERING DEVELOPER: DII MANAGEMENT, LLC.

PRELIMINARY APPROVAL FINAL APPROVAL FINAL APPROVAL WITH FINANCIAL GUARANTEE WITH VARIANCE

NUMBER OF LOTS: 52 *SINGLE FAMILY *MULTI-FAMILY COMMERCIAL INSTITUTIONAL

NUMBER OF STREETLIGHTS: 7

FILLING STATIONS: 6

LOCATION DESCRIPTION: WEST SIDE OF MILE 6 1/2 WEST ROAD AND APPROXIMATELY 1/4 OF A MILE SOUTH OF MILE 10 NORTH ROAD.

SUBDIVISION LIES WITHIN THE: ETJ OF WESLACO

DRAINAGE REPORT WAS APPROVED BY HCDD#1: ON 9-27-2022 PROPERTY LIES WITHIN FLOOD ZONE: "X" AS PER FEMA.

DRAINAGE DESIGN: DRAINAGE WILL BE PROVIDED BY STORM SEWER SYSTEM AND DETENTION WILL BE PROVIDED BY WIDENING THE EXISTING DRAIN DITCH.

ROAD R.O.W. DEDICATION: 25.0 FEET ONTO MILE 6 1/2 WEST ROAD.

H.C.R.O.W. FINAL APPROVAL DATE: 2-21-2023 BY, DANNY GUZMAN, PCT.1 R.O.W. AGENT

H.C.H.D. FINAL APPROVAL DATE: 2-21-2023 BY, ENVIRONMENTAL HEALTH DIVISION MANAGER
SEWER SYSTEM: OSSF'S HAVE BEEN ESCROWED.

WATER SERVICE PROVIDER: N.A.W.S.C. LINE SIZE: 8" LOCATION: MILE 6 1/2 WEST ROAD

H.C.E.O.C. FINAL APPROVAL DATE: 2-21-2023 : BY ENVIRONMENTAL COMPLIANCE COORDINATOR

LARGE CONSTRUCTION

The applicant has submitted the required NOI as per Part II, Section E of the TPDES General Permit for Construction Activities (TXR150000) along with a copy of the Erosion Control Plan for the proposed Project.

REQUEST FOR FINAL APPROVAL WITH: **CASH DEPOSIT: Amount: \$78,000.00 For: (52) OSSF'S.**

PRELIMINARY APPROVAL FROM THE
HIDALGO COUNTY COMMISSIONERS COURT ON: NOVEMBER 15, 2022

STAFF RECOMMENDS: **Preliminary Approval** subject to comments and future recommendations by planning,
Other departments and the approval of the City of Weslaco.

Final Approval with financial guarantee.

*This subdivision plat has been reviewed and complies with the Hidalgo County Subdivision Rules,
Texas Water Development Board Model Subdivision Rules and The Texas Local Government Code.*

SIENNA RIDGE SUBDIVISION

A 31.06 ACRE TRACT OF LAND OUT OF FARM TRACT 216, WEST TRACT SUBDIVISION AS PER MAP RECORDED IN VOLUME 2, PAGES 34-37, MAP RECORDS, HIDALGO COUNTY, TEXAS.

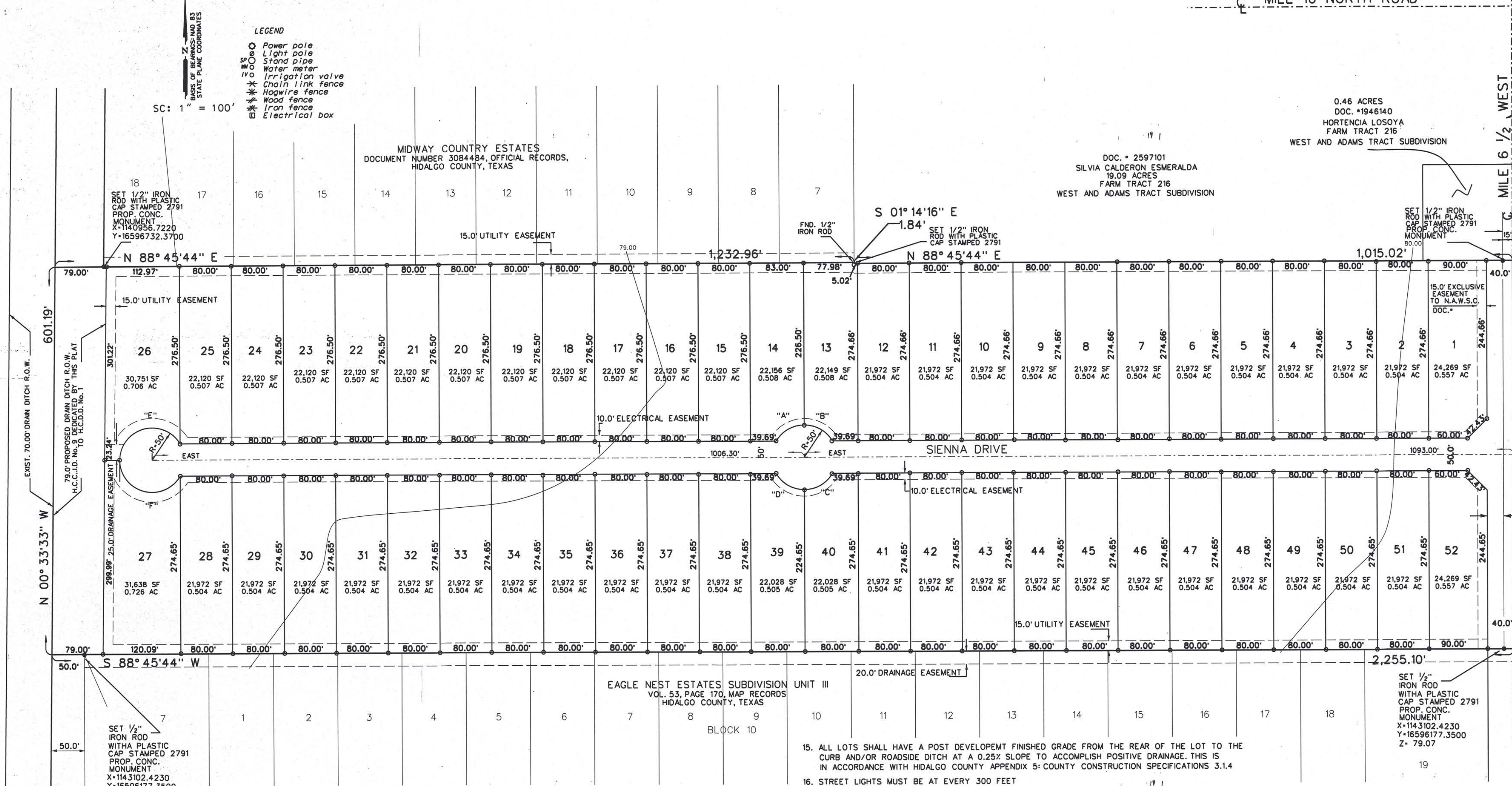

GENERAL NOTES:

- MIN. BUILDING SETBACK LINES: FRONT 25.0' CORNER 10.0' OR EASEMENT WHICH EVER IS GREATER SIDE 6.0' OR EASEMENT WHICH EVER IS GREATER REAR 25.0' OR EASEMENT WHICH EVER IS GREATER 20.0' GARAGE / CAR PORT FRONT SET BACK
- MINIMUM FINISH FLOOR NOTES: MINIMUM FINISH FLOOR ELEVATION SHALL BE 18" ABOVE TOP OF CURB 18" ABOVE NATURAL GROUND, WHICHEVER IS GREATER ELEVATION CERTIFICATE MAY BE REQUIRED FOR LOTS LOCATED OUTSIDE A DESIGNATED FLOOD ZONE AT THE TIME FOR APPLICATION FOR CONSTRUCTION TO VERIFY PRE AND POST CONSTRUCTION FINISH FLOOR ELEVATIONS. AN ELEVATION CERTIFICATE SHALL BE REQUIRED FOR ALL LOTS WITHIN A DESIGNATED FLOOD ZONE AT THE TIME FOR A DEVELOPMENT PERMIT APPLICATION. MIN. F.F. ELEV. = 79.50
- DENOTES 1/2" IRON ROD FOUND UNLESS OTHERWISE NOTED ● DENOTES 1/2" IRON ROD SET UNLESS OTHERWISE NOTED. BM * 276.00 - DENOTES NAIL FOUND UNLESS OTHERWISE NOTED.
- BENCH MARK *180.79' TOP OF MANHOLE ON THE EAST SIDE OF MILE 6 1/2 WEST BENCH MARK *79.89, SET NAIL AT NORTHEAST CORNER OF THIS SUBDIVISION
- FLOOD ZONE DESIGNATION ZONE "X" AREAS DETERMINED TO BE OUTSIDE 500-YEAR FLOOD PLAIN. C.F.N. 480334 0450 C.M. REVISED JUNE 5, 2000. REVISOR TO REFLECT LUMP EFFECTIVE OCTOBER 5, 2018 CONSTRUCTION OF RESIDENTIAL HOUSING WITHIN ANY OF THE SUBDIVISION THAT IS IN THE 100-YEAR FLOOD PLAIN IS PROHIBITED UNLESS THE HOUSING QUALIFIES FOR INSURANCE UNDER THE NATIONAL FLOOD INSURANCE ACT OF 1968 (42 U.S.C. SECTIONS 4001 THROUGH 4127).

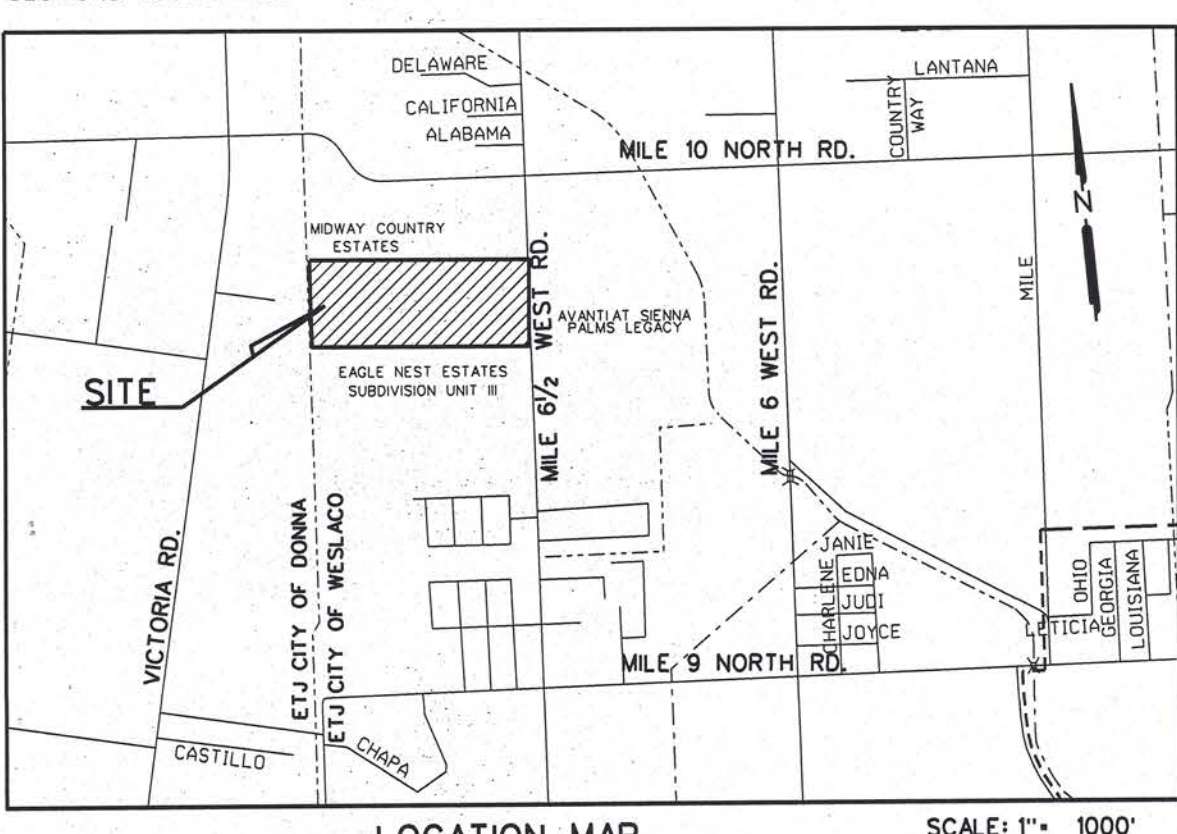

LOCATION OF SUBDIVISION WITH RESPECT TO THE EXTRATERRITORIAL JURISDICTION OF A MUNICIPALITY: SIENNA RIDGE SUBDIVISION IS LOCATED WITHIN HIDALGO COUNTY PRECINCT NO. 1 IN THE CENTRAL EAST OF HIDALGO COUNTY ON THE WEST SIDE OF MILE 6 1/2 WEST ROAD 1050.78 FEET SOUTH OF MILE 10 NORTH ROAD. THE ONLY NEARBY MUNICIPALITY IS THE CITY OF WESLACO ACCORDING TO THE MAP IN THE OFFICE OF THE SECRETARY OF THE CITY OF WESLACO (POPULATION 37,791/2015 CENSUS). SIENNA SUBDIVISION LIES APPROXIMATELY 1.1 MILES FROM THE CITY LIMITS OF WESLACO AND LIES WITHIN THE CITY'S 3.5 MILE EXTRATERRITORIAL JURISDICTION (ETJ) UNDER LOCAL GOVERNMENT CODE § 42.021

6. DRAINAGE:
IN ACCORDANCE WITH THE HIDALGO COUNTY DRAINAGE DISTRICT NO. 1 AND HIDALGO COUNTY REQUIREMENTS, THIS DEVELOPMENT WILL BE REQUIRED TO DETAIN A TOTAL OF 83,827 CUBIC FEET (1.92 ACRE-FEET) OF STORM WATER RUNOFF. DRAINAGE DETENTION IN ACCORDANCE WITH THE LOCAL REQUIREMENTS WILL BE ACCOMPLISHED AS FOLLOWS: THE DRAINAGE FOR THIS DEVELOPMENT WILL BE SELF-CONTAINED WITHIN THE SUBDIVISION THE DEVELOPER SHALL BE RESPONSIBLE FOR DETAINING AND ACCOMMODATING MORE THAN THE DETAINED VOLUME SHOWN ON THIS PLAT IF IT IS DETERMINED, AT THE PERMIT STAGE, THAT THE DETENTION REQUIREMENTS ARE GREATER THAN STATED ON THIS PLAT.

7. NO STRUCTURE SHALL BE PERMITTED OVER ANY EASEMENT.
EASEMENTS SHALL BE KEPT CLEAR OF FENCES, BUILDINGS, SHEDS, SHRUBS TREES, AND OTHER PLANTINGS (EXCEPT LOW, LESS THAN 18 INCHES MATURE HEIGHT, GROUND COVER, GRASS, OR FLOWERS) AND OTHER OBSTRUCTIONS THAT WOULD INTERFERE WITH THE OPERATIONS AND MAINTENANCE OF THE EASEMENT.

8. GENERAL NOTE FOR SINGLE FAMILY RESIDENCES:
NO MORE THAN ONE-SINGLE FAMILY DETACHED DWELLING SHALL BE LOCATED ON EACH LOT. APPLICATIONS FOR CONSTRUCTION ARE REQUIRED PRIOR TO OCCUPANCY OF THE LOT.

9. ON-SITE SEWAGE FACILITIES (OSSF) NOTE:
THIS SUBDIVISION SHALL USE ON-SITE SEWAGE FACILITIES IN ACCORDANCE WITH TCEQ AND HIDALGO COUNTY REGULATIONS FOR SEWAGE DISPOSAL. THE SUBDIVIDER IS RESPONSIBLE FOR PROVIDING AN OSSF ON ALL LOTS.

A. OSSF SYSTEM IS BEING DESIGNED FOR DISPOSAL OF DOMESTIC SEWAGE ONLY.

B. EACH LOT ON THIS PLAT COMPLIES WITH THE MINIMUM 21,780 SQUARE FEET LOT AREA WITH POTABLE WATER SUPPLY.

C. OSSF SYSTEM SHALL REQUIRE INSPECTION AND APPROVAL BY HIDALGO COUNTY AUTHORIZED DEPARTMENT

D. SOIL ANALYSIS HAVE BEEN SUBMITTED TO THE AUTHORIZED HIDALGO COUNTY DEPARTMENT AND EXPERTS MAY BE ALSO BEEN ON THE UTILITY LAYOUT FOR THIS SUBDIVISION AS SUBMITTED TO THE HIDALGO COUNTY PLANNING DEPARTMENT. THE ENGINEER HAS DETERMINED THAT THE SOIL IS SUITABLE FOR A STANDARD SEPTIC TANK AND ABSORPTIVE DRAINFIELD SYSTEM.

E. APPROVED "OSSF" PERMIT APPLICATION IS REQUIRED INCLUDING INDIVIDUAL LOT PLANNING MATERIALS PRIOR TO OCCUPANCY OF A LOT.

F. A SPECIAL DESIGN IS REQUIRED FOR ALL OSSF SYSTEMS LOCATED WITHIN A DESIGNATED FLOOD ZONE. THE DESIGN SHALL INCLUDE BUT NOT LIMITED TO THE FOLLOWING ITEMS:

- ANCHORING OF SEPTIC TANK(S)
- BACK FLOW VALVES
- SEPTIC TANK COVER SHALL BE ABLE TO SEAL

10. THERE ARE NO WATER WELLS WITHIN 150 FEET FROM THE BOUNDARIES OF THIS SUBDIVISION.

11. ALBERT HANKS, THE OWNER & SUBDIVIDERS OF SIENNA RIDGE SUBDIVISION RETAINS AN EASEMENT UPON EACH LOT FOR THE PURPOSE OF INSTALLING AN APPROVED OSSF ON THE LOT AS DESCRIBED ON SHEET NO. 2 OF THIS PLAT.

12. EACH PURCHASED CONTRACT MADE BETWEEN A SUBDIVIDER AND PURCHASER OF A LOT IN THIS SUBDIVISION SHALL CONTAIN A STATEMENT DESCRIBING HOW AND WHEN WATER, SEWER, ELECTRICITY, AND GAS SERVICES WILL BE MADE AVAILABLE TO THE SUBDIVISION.

13. ALL PUBLIC UTILITIES EASEMENTS DEDICATED BY THIS PLAT SHALL BE A MINIMUM WIDTH OF 15.00 FEET AS PER THE HIDALGO COUNTY MAP SUBDIVISION RULES. BY SIGNING THIS PLAT DEVELOPER AND ENGINEER CERTIFY THAT ALL OTHER EASEMENTS SHOWN COMPLY WITH THE SIZE REQUIRED BY EACH UTILITY PROVIDER OCCUPANCY AN EASEMENT.

14. FIRE HYDRANTS INSTALLED WITHIN THE CORPORATION'S DISTRIBUTION SYSTEM ARE PROVIDED AT THE CONVENIENCE OF THE CORPORATION AND DO NOT IMPLY ANY RESPONSIBILITY ON THE PART OF THE CORPORATION TO MEET FIRE FLOW REQUIREMENTS.

15. ALL LOTS SHALL HAVE A POST DEVELOPMENT FINISHED GRADE FROM THE REAR OF THE LOT TO THE CURB AND/OR ROADSIDE DITCH AT A 0.25% SLOPE TO ACCOMPLISH POSITIVE DRAINAGE. THIS IS IN ACCORDANCE WITH HIDALGO COUNTY APPENDIX 5-COMMUNITY CONSTRUCTION SPECIFICATIONS 3.1.4

16. STREET LIGHTS MUST BE AT EVERY 300 FEET

17. A 5.0' CONC SIDEWALK IS REQUIRED ALONG EXTERIOR PERIMETER DURING CONSTRUCTION OF SUBDIVISION

18. A 4.0' CONC SIDEWALK IS REQUIRED ALONG ALL INTERIOR STREET PERIMETER UPON THE THE ISSUANCE OF BUILDING PERMIT AS REQUIRED BY CITY OF WESLACO

19. NO ACCESS WILL BE ALLOWED FROM MILE 6 1/2 WEST FOR LOTS 1 AND 52

20. CORNER LOTS DRIVEWAYS SHOULD BE CONSTRUCTED AT FURTHEST POSSIBLE POINT FROM INTERSECTIONS AND IN COMPLIANCE WITH ACCESS MANAGEMENT ORDINANCE

I, THE UNDERSIGNED, THE MAYOR OF THE CITY OF WESLACO, TEXAS, HEREBY CERTIFY THAT THIS SUBDIVISION PLAT CONFORMS TO ALL REQUIREMENTS OF THE SUBDIVISION REGULATIONS OF THIS CITY WHEREIN MY APPROVAL IS REQUIRED.

MAYOR, CITY OF WESLACO DATE _____ CITY SECRETARY DATE _____

THIS SUBDIVISION PLAT OF SIENNA RIDGE SUBDIVISION BEEN SUBMITTED SUBDIVISION TO AND CONSIDERED BY THE PLANNING COMMISSION OF THE CITY OF WESLACO, TEXAS, AND IS HEREBY APPROVED BY SUCH COMMISSION. DATED THIS _____ DAY OF _____, 2022 A.D.

CHAIRMAN, PLANNING & ZONING COMMISSION _____

COUNTY OF HIDALGO CERTIFICATE OF PLAT APPROVAL

I, THE UNDERSIGNED CERTIFY THAT THIS PLAT OF SIENNA RIDGE SUBDIVISION WAS REVIEWED AND APPROVED BY THE HIDALGO COUNTY HEALTH DEPARTMENT ON _____ DATE _____

HIDALGO COUNTY ENVIRONMENTAL HEALTH DIVISION MANAGER _____ DATE _____

HIDALGO COUNTY CERTIFICATE OF PLAT APPROVAL UNDER LOCAL GOVERNMENT CODE § 232.028(A)

WE THE UNDERSIGNED CERTIFY THAT THIS PLAT OF SIENNA RIDGE SUBDIVISION WAS REVIEWED AND APPROVED BY THE HIDALGO COUNTY COMMISSIONERS COURT ON _____, 2022

HIDALGO COUNTY JUDGE DATE _____

ATTEST: _____ HIDALGO COUNTY CLERK DATE _____

STATE OF TEXAS COUNTY OF HIDALGO

I, THE UNDERSIGNED, GUILLERMO A. ARRATIA, A LICENSED PROFESSIONAL ENGINEER, IN THE STATE OF TEXAS, DO HEREBY CERTIFY THAT THE PROPER ENGINEERING CONSIDERATION HAS BEEN GIVEN TO THIS PLAT.

Guillermo Arratia PE 11/15/2022
GUILLERMO A. ARRATIA LICENSED PROFESSIONAL ENGINEER No. 94001 266 N. 5TH ST. DONNA, TEXAS, 78537

PRINCIPAL CONTACTS: NAME ADDRESS CITY & ZIP PHONE
OWNER: ALBERT HANKS 502 E. EXPRESSWAY 83, SUITE C WESLACO, TEXAS, 78596 956-630-0216
ENGINEER: GUILLERMO A. ARRATIA 526 N. 5TH ST. DONNA, TX 78537 (956) 784-0218
SURVEYOR: HOMERO GUTIERREZ 2600 SAN DIEGO MISSION, TX (956) 369-0988

RIGHT OF WAY EASEMENT
KNOW ALL MEN BY THESE PRESENTS, THAT THE UNDERSIGNED, OWNERS OF THE PROPERTY SHOWN ON THIS PLAT, THEIR SUCCESSORS, ASSIGNS, AND TRANSFEREES (HEREINAFTER CALLED "GRANTOR") WHETHER ONE OR MORE PERSONS ARE NAMED, IN CONSIDERATION OF ONE DOLLAR (\$1.00) AND OTHER GOOD AND VALUABLE CONSIDERATION PAID BY NORTH ALAMO WATER SUPPLY CORPORATION, (HEREINAFTER CALLED "GRANTEE") THE RECEIPT AND SUFFICIENCY OF WHICH IS HEREBY ACKNOWLEDGED, DOES HEREBY GRANT, BARGAIN, SELL, TRANSFER, AND CONVEY TO SAID GRANTEE, ITS SUCCESSORS, AND ASSIGNS, AN EXCLUSIVE EASEMENT WITH THE RIGHT TO ERECT, CONSTRUCT, INSTALL AND THEREAFTER USE, OPERATE, INSPECT, REPAIR, MAINTAIN, REPLACE, AND REMOVE WATER DISTRIBUTION LINES AND APPURTENANCES OVER AND ACROSS THE LANDS SHOWN ON THIS PLAT, TOGETHER WITH THE RIGHT OF INGRESS AND EGRESS OVER GRANTOR'S ADJACENT LANDS OF THE PURPOSE FOR WHICH THE ABOVE MENTIONED RIGHTS ARE GRANTED. THE EASEMENT HEREBY GRANTED SHALL NOT EXCEED 15' IN WIDTH, AND GRANTEE IS HEREBY AUTHORIZED TO DESIGNATE THE COURSE OF THE EASEMENT HEREIN CONVEYED EXCEPT THAT WHEN THE PIPELINE(S) IS INSTALLED, THE EASEMENT HEREIN GRANTED SHALL BE LIMITED TO A STRIP OF LAND 15' IN WIDTH, THE CENTER LINE THEREOF BEING THE PIPELINE INSTALLED. IN THE EVENT THE EASEMENT HEREBY GRANTED BEGINS AT A PUBLIC ROAD AND THE CITY COUNTY OR STATE HEREAFTER WIDENS OR RELOCATES THE PUBLIC ROAD SO AS TO REQUIRE THE RELOCATION OF THIS WATERLINE AS INSTALLED, GRANTEE FURTHER GRANTS TO GRANTEE AN ADDITIONAL EASEMENT OVER AND ACROSS THE LAND SHOWN ON THIS PLAT FOR THE PURPOSE OF LATERALLY RELOCATE SAID WATER LINE AS MAY BE NECESSARY TO CLEAR THE ROAD IMPROVEMENTS, WHICH EASEMENT HEREBY GRANTED SHALL BE LIMITED TO A STRIP OF LAND 15' IN WIDTH, THE CENTER LINE THEREOF BEING THE PIPELINE AS RELOCATED. THE CONSIDERATION RECITED HEREIN SHALL CONSTITUTE PAYMENT IN FULL FOR ALL DAMAGES SUSTAINED BY GRANTEE BY REASON OF THE INSTALLATION, MAINTENANCE, REPAIR, REPLACEMENT AND RELOCATION OF THE STRUCTURES REFERRED TO HEREIN, THIS AGREEMENT TOGETHER WITH OTHER PROVISIONS OF THIS GRANT SHALL CONSTITUTE AN EASEMENT FOR THE BENEFIT OF THE GRANTEE, ITS SUCCESSORS, AND ASSIGNS. THE GRANTEE CONSENTS THAT IT IS THE OWNER OF THE ABOVE-DESCRIBED LANDS AND THAT SAID LANDS ARE FREE AND CLEAR OF ALL ENCUMBRANCES AND LIES EXCEPT THE FOLLOWING: THE EASEMENT CONVEYED HEREIN WAS OBTAINED OR IMPROVED THROUGH FEDERAL FINANCIAL ASSISTANCE. THIS EASEMENT IS SUBJECT TO THE PROVISIONS OF TITLE VI OF THE CIVIL RIGHTS ACT OF 1964 AND THE REGULATIONS ISSUED PURSUANT THERETO FOR SO LONG AS THE EASEMENT CONTINUES TO BE USED FOR THE SAME OR SIMILAR PURPOSE FOR WHICH FINANCIAL ASSISTANCE WAS EXTENDED OR FOR SO LONG AS THE GRANTEE OWNS IT, WHICHEVER IS LONGER.

WITNESS WHEREOF THE SAID GRANTEE EXECUTED THIS INSTRUMENT THIS DAY OF _____, 2022

OWNER: DIMANAGEMENT LLC
ALBERT HANKS - MANAGER OF DIMANAGEMENT, LLC
ADDRESS: 502 E. EXPRESSWAY 83, SUITE G
WESLACO, TEXAS, 78596

FILED FOR RECORD IN HIDALGO COUNTY ARTURO GUJARDO, JR. HIDALGO COUNTY CLERK

ON: _____ AT _____ AM/PM INSTRUMENT NUMBER _____ OF THE MAP RECORDS OF HIDALGO COUNTY, TEXAS

By: _____ DEPUTY DATE OF PREPARATION: JULY 17, 2022

PH: (956) 784-0218 E-MAIL: NANENGINEERING@AHOOC.COM

CURVE TABLE

NO.	RADIUS	LENGTH	DELTA	CHORD	BEARING
A	50.0'	52.36'	60°00'00"	50.0'	S 60°00'00" W
B	50.0'	52.36'	60°00'00"	50.0'	N 60°00'00" W
C	50.0'	52.36'	60°00'00"	50.0'	N 60°00'00" E
D	50.0'	52.36'	60°00'00"	50.0'	S 60°00'00" E
E	50.0'	130.89'	180°00'00"	98.59'	S 74°59'52" W
F	50.0'	130.89'	180°00'00"	98.59'	S 74°59'52" E

APPROVED BY DRAINAGE DISTRICT: HIDALGO COUNTY DRAINAGE DISTRICT NO. 1 HEREBY CERTIFIES THAT THE DRAINAGE PLANS FOR THIS SUBDIVISION COMPLY WITH THE MINIMUM STANDARDS OF THE DISTRICT ADOPTED UNDER TEXAS SUBCHAPTER 49.21(c), THE DISTRICT HAS REVIEWED AND DOES NOT CERTIFY THAT THE DRAINAGE STRUCTURES DESCRIBED ARE APPROPRIATE FOR THE SPECIFIC SUBDIVISION, BASED ON GENERALLY ACCEPTED ENGINEERING CRITERIA. IT IS THE RESPONSIBILITY OF THE DEVELOPER AND HIS ENGINEER TO MAKE THEIR DETERMINATIONS.

HIDALGO COUNTY DRAINAGE DISTRICT NO. 1
RAUL E. SESIN, P.E., C.F.M. DATE _____

GENERAL MANAGER HIDALGO & CAMERON COUNTIES IRRIGATION DISTRICT NO. 9
THIS PLAT IS APPROVED BY THE HIDALGO AND CAMERON COUNTIES IRRIGATION DISTRICT NO. 9
DATED THIS _____ DAY OF _____, 2022

1. NO IMPROVEMENTS OF ANY KIND SHALL BE PLACED UPON HIDALGO AND CAMERON COUNTIES IRRIGATION DISTRICT NO. 9 RIGHT-OF-WAYS AND/OR EASEMENTS WITHOUT THE EXPRESSED WRITTEN PERMISSION OF H.C.C.I.D. NO. 9

2. IT IS UNDERSTOOD THAT THE RATE OF FLOW OF STORM WATER FOR THE DEVELOPMENT WILL BE NO GREATER THAN THE RATE OF FLOW OF STORM WATER WHEN THE LAND WAS IN AGRICULTURAL USE.

3. H.C.C.I.D. NO. 9 WILL NOT BE RESPONSIBLE FOR STORM/DRAINAGE WATER SYSTEM TO ANY LOT WITHIN THIS SUBDIVISION AS WELL AS H.C.C.I.D. NO. 9 WILL NOT BE RESPONSIBLE FOR THE DELIVERY OF WATER TO ANY LOT WITHIN THIS SUBDIVISION IF DESIRED, THIS WILL NOT BE AT THE DISTRICT EXPENSE.

4. H.C.C.I.D. NO. 9 HAS NOT REVIEWED AND DOES NOT CERTIFY THAT THE STORM SEWER OR UTILITIES SYSTEMS DESCRIBED ARE APPROPRIATE FOR THE PARTICULAR SUBDIVISION, BASED ON GENERALLY ACCEPTED ENGINEERING CRITERIA. THE DEVELOPER AND HIS ENGINEER ARE RESPONSIBLE FOR THEIR DETERMINATIONS.

5. H.C.C.I.D. NO. 9 EXCLUSIVE EASEMENTS SHALL BE KEPT CLEAR OF BUILDINGS, SHEDS, FENCES, SHRUBS, TREES, AND OTHER PLANTINGS AND OTHER OBSTRUCTIONS THAT WOULD INTERFERE WITH THE OPERATIONS AND MAINTENANCE OF THE EASEMENT.

GENERAL MANAGER HIDALGO & CAMERON COUNTIES IRRIGATION DISTRICT NO. 9
STATE OF TEXAS COUNTY OF HIDALGO
HOMERO LUIS GUTIERREZ, A REGISTERED PROFESSIONAL LAND SURVEYOR IN THE STATE OF TEXAS HEREBY CERTIFY THAT THIS PLAT IS TRUE AND CORRECTLY MADE AND IS PREPARED FROM AN ACTUAL SURVEY ON THE PROPERTY MADE UNDER MY SUPERVISION ON THE GROUND AND THAT THE CORNER MONUMENTS WERE PROPERLY PLACED UNDER MY SUPERVISION.

INDEX TO SHEET OF SIENNA RIDGE SUBDIVISION
SHEET 1: HEADINGS: INDEX; LOCATION MAP AND ETJ; PRINCIPAL CONTACTS; PLAT WITH DITS, STREETS, AND EASEMENT DESIGNATIONS; LEGAL DESCRIPTION (LIMITS AND BOUNDS); SURVEYOR'S AND ENGINEER'S CERTIFICATION; PLAT NOTES AND RESTRICTIONS; OWNER'S DEDICATION, CERTIFICATION, AND ATTESTATION; COUNTY APPROVAL CERTIFICATE; COUNTY CLERK'S RECORDING CERTIFICATE; HIDALGO COUNTY CERTIFICATE OF APPROVAL; REVISION NOTES; H.C.C.I.D. NO. 9 CITY PLANNING AND CITY COMMISSION'S CERTIFICATION AND CITY COUNCIL CERTIFICATION.
SHEET 2: WATER DISTRIBUTION AND ON-SITE SEWAGE FACILITY, ENGINEERING REPORT (INCLUDING DESCRIPTION OF DRAINAGE AND HOW IT WILL SERVE WATER AND WASTE WATER AND ENGINEER'S CERTIFICATION (ENGLISH AND SPANISH VERSION); TYPICAL WATER SERVICE CONNECTION; OWNER'S DEDICATION, CERTIFICATION, AND ATTESTATION.
SHEET 3: DRAINAGE REPORT INCLUDING DESCRIPTION OF DRAINAGE AND HOW IT WILL SERVE THIS DEVELOPMENT; MAP OF TOPOGRAPHY AND DRAINAGE; AND ENGINEER'S CERTIFICATION; REVISION NOTES; CONSTRUCTION DETAILS.

MAP OF WATER DISTRIBUTION SYSTEM
MAPA DE DISTRIBUCION DE AGUA

SIENNA RIDGE SUBDIVISION

A 31.06 ACRE TRACT OF LAND OUT OF FARM
TRACT 216, WEST TRACT SUBDIVISION AS PER MAP RECORDED IN VOLUME 2,
PAGES 34-37, MAP RECORDS, HIDALGO COUNTY, TEXAS.

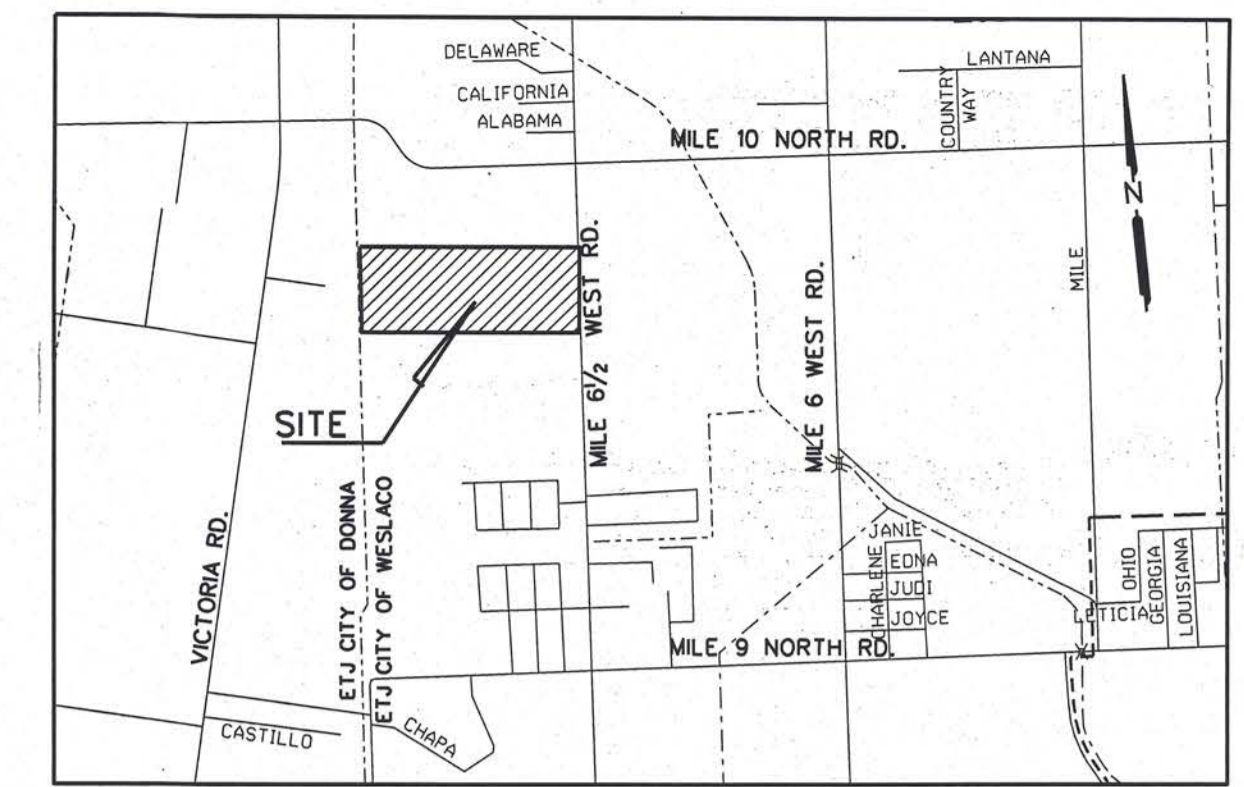

LOCATION OF SUBDIVISION WITH RESPECT TO THE EXTRATERRITORIAL JURISDICTION OF A MUNICIPALITY:
SIENNA RIDGE SUBDIVISION IS LOCATED WITHIN HIDALGO COUNTY PRECINCT NO. 1 IN THE CENTRAL EAST OF HIDALGO COUNTY ON THE WEST SIDE OF MILE 6 1/2 WEST ROAD 1050.78 FEET SOUTH OF MILE 10 NORTH ROAD. THE ONLY NEARBY MUNICIPALITY IS THE CITY OF WESLACO ACCORDING TO THE MAP IN THE OFFICE OF THE SECRETARY OF THE CITY OF WESLACO (POPULATION 37,781 2015 CENSUS). SIENNA SUBDIVISION LIES APPROXIMATELY 1.1 MILES FROM THE CITY LIMITS OF WESLACO AND LIES WITHIN THE CITY'S 3.5 MILE EXTRATERRITORIAL JURISDICTION (ETJ) UNDER LOCAL GOVERNMENT CODE § 42.021

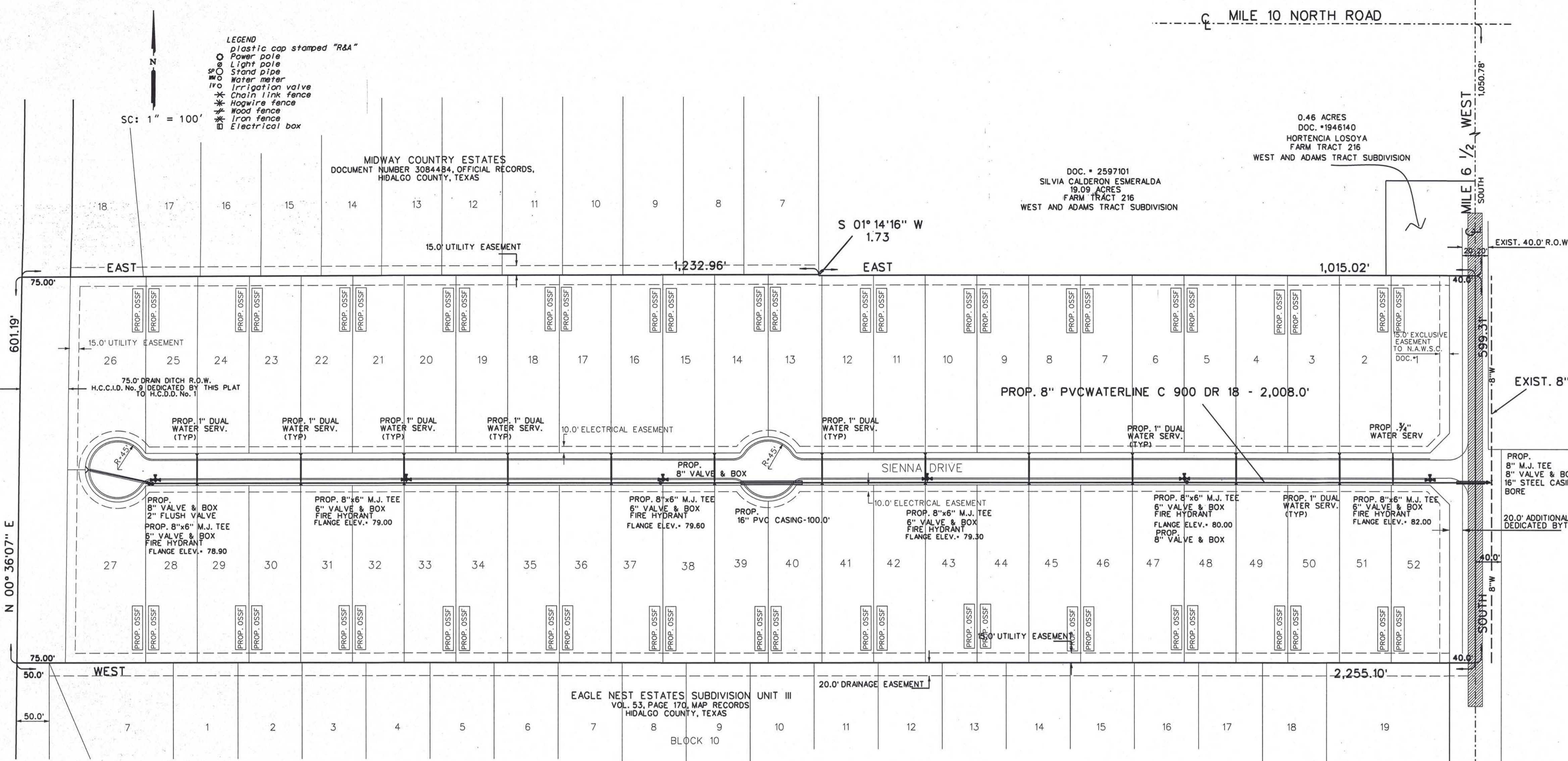

SUBDIVIDER CERTIFICATION:
1.- BY COMPLETING THE IMPROVEMENTS DESCRIBED ON THE PLAT, SUBDIVIDER WILL COMPLY WITH MINIMUM STATE STANDARDS AND THAT (a) WATER QUALITY AND CONNECTIONS INCLUDING WATER METERS TO THE LOT MEET SUCH STANDARDS AND (b) SEWER CONNECTIONS TO THE LOT OR SEPTIC TANK MEET OR WILL MEET SUCH STANDARDS AND WILL BE BY STATE AND COUNTY REGULATIONS.

SUBDIVIDER STATEMENT:
1.- ALBERT HANK SUBDIVIDER OF SIENNA SUBDIVISION HEREBY CERTIFY SEWER PERMITS HAVE BEEN PAID AND ARE ON FILE WITH THE HIDALGO COUNTY HEALTH DEPARTMENT THAT ANY ADEQUATE DRINKING WATER SOURCE IS IMMEDIATELY AVAILABLE TO EACH LOT OF THE TYPE, QUALITY & QUANTITY TO ENABLE EACH PERSON PURCHASING A LOT HAVE ADEQUATE WATER TO COMPLY WITH THE REGULATIONS AND THE LAWS TO THE STATE AS REQUIRED BY STATE AND COUNTY REGULATIONS.

FINAL WATER AND SEWER ENGINEERING REPORT
WATER SUPPLY: DESCRIPTION, COST, AND OPERABILITY DATES:
SIENNA RIDGE SUBDIVISION WILL BE PROVIDED WITH POTABLE WATER BY THE NORTH ALAMO WATER SUPPLY (N.A.W.S.C.) THE SUBDIVIDER, AND N.A.W.S.C., HAVE ENTERED INTO A CONTRACT IN WHICH N.A.W.S.C. HAS PROMISED TO PROVIDE SUFFICIENT WATER TO THE SUBDIVISION FOR AT LEAST 30 YEARS AND N.A.W.S.C. HAS PROVIDED DOCUMENTATION TO SUFFICIENTLY ESTABLISH THE LONG TERM QUANTITY AND QUALITY OF THE AVAILABLE WATER SUPPLIES TO SERVE THE FULL DEVELOPMENT OF THIS SUBDIVISION.
N.A.W.S.C. HAS AN EXISTING 8" DIAMETER WATERLINE RUNNING ALONG THE EAST RIGHT-OF-WAY OF MILE 6 1/2 WEST ROAD WATER DISTRIBUTION FOR SIENNA RIDGE SUBDIVISION CONSIST OF A PROPOSED 8 INCH PVC WATERLINE TO THE EXISTING 8 INCH WATERLINE AND 10 2" DUAL SERVICES, 2 - 3/4" DIAMETER WATER SERVICES AND 4 FIRE HYDRANTS.
FOR THIS SUBDIVISION, SAID SERVICES TERMINATE AT THE WATER METER BOX, AND THE METER BOX HAVE ALREADY BEEN INSTALLED AT A TOTAL COST OF \$45,000.00, IN ADDITION THE SUBDIVIDER HAS PAID N.A.W.S.C. THE SUM OF \$17,500.00, WHICH COVERS THE COST FOR ALL THE LOTS, AS STATED IN THE 30 YEAR WATER SERVICE AGREEMENT WHICH SUM REPRESENTS THE TOTAL COST OF THE WATER METER, RIGHTS ACQUISITION FEES, AND ALL MEMBERSHIP OR OTHER FEES ASSOCIATED WITH CONNECTING THE INDIVIDUAL LOT IN THE SUBDIVISION TO N.A.W.S.C., UPON REQUEST BY THE LOT OWNER, N.A.W.S.C. WILL PROMPTLY INSTALL AT NO CHARGE THE WATER METER.
THE ENTIRE WATER FACILITIES HAVE BEEN APPROVED AND ACCEPTED BY N.A.W.S.C., AND SAID DISTRIBUTION SYSTEM IS OPERABLE AS OF THE DATE OF THE RECORDING OF THE PLAT.

SEWAGE FACILITIES: DESCRIPTION, COSTS, AND OPERABILITY DATES:
SEWAGE FROM SIENNA RIDGE SUBDIVISION WILL BE TREATED BY INDIVIDUAL ON-SITE SEWAGE FACILITIES ("OSSF") CONSISTING OF A STANDARD DESIGN DUAL COMPARTMENTS SEPTIC TANK AND A DRAIN FIELD ON THIS LOT. THE SITE EVALUATOR GUSTAVO CHAPA REG. # 9754, HAS EVALUATED THE SUITABILITY OF THE SUBDIVISION SITE FOR OSSF AND SUBMITTED A REPORT CONCLUDING THAT THE SITE IS SUITABLE FOR OSSF. THE REPORT WAS REVIEWED AND APPROVED BY THE HIDALGO COUNTY HEALTH DEPARTMENT. EACH LOT HAS ADEQUATE AREA FOR A REPLACEMENTS DRAIN FIELD.
EACH LOT IN THE PROPOSED SUBDIVISION IS AT LEAST 1/2 ACRE IN SIZE. THE NATURAL RESOURCE CONSERVATION SERVICE SOIL SURVEY BOOK INDICATED A SANDY LOAM SOIL FOR THE AREA. AT LEAST TWO SOIL EXCAVATIONS WERE PERFORMED ON THE SITE, AT OPPOSITE ENDS OF THE SOIL IS A TEXTURE CLASS II SANDY LOAM BLOCKY EXTENDING UP TO 36" BELOW THE BOTTOM OF ANY PROPOSED EXCAVATIONS. THERE IS NO INDICATION OF GROUNDWATER OR A RESTRICTIVE LAYER WITHIN 24" OF BOTTOM OF THE PROPOSED EXCAVATIONS. THE SUBDIVISION DRAINS WELL.
THE ESTIMATED COST TO INSTALL A SEPTIC SYSTEM ON AN INDIVIDUAL LOT IS \$1,500.00 INCLUDING THE COST FOR THE REQUIRED PERMIT AND LICENSE. ALL OSSF'S HAVE BEEN INSTALLED AS OF THE TIME OF APPLICATION FOR FINAL PLAT APPROVAL, WITH THE FILING OF THIS PLAT, THE SUBDIVIDER IS PROVIDING ADEQUATE FINANCIAL GUARANTEES OF PERFORMANCE IN THE FORM OF A (CASHIERS CHECK OR PERSONAL CHECK) REPRESENTING A "CASH DEPOSIT TO BE HELD BY THE COUNTY OF HIDALGO IN ESCROW IN THE AMOUNT OF \$78,000.00 WHICH IS THE ESTIMATED TOTAL COST TO INSTALL A SEPTIC TANK SYSTEM ON EACH LOT. THE SUBDIVIDER WILL INCLUDE THE COST OF A SEPTIC TANK SYSTEM IN THE SALE PRICE OF THE LOT.
AT ANY TIME AFTER THE LOT IS SOLD, THE PURCHASER MAY INITIATE INSTALLATION OF AN OSSF SYSTEM BY WRITING OR CALLING THE SUBDIVIDER. SUBDIVIDER SHALL BE RESPONSIBLE TO FILE WITH THE HIDALGO COUNTY HEALTH DEPARTMENT AN APPLICATION FOR A PERMIT TO INSTALL AN OSSF. THE OSSF SYSTEM SHALL BE INSTALLED ON THE LOT PRIOR TO THE COUNTY ISSUING A FINAL LIGHT AND WATER CLEARANCE. THERE IS AN EXISTING SEPTIC TANK SYSTEM IN THIS SUBDIVISION

ENGINEER CERTIFICATION:
BY MY SIGNATURE BELOW, I CERTIFY THAT THE WATER AND SEWAGE SERVICE FACILITIES DESCRIBED ABOVE ARE IN COMPLIANCE WITH THE MODEL RULES ADOPTED UNDER SECTION 16.343, WATER CODE, I CERTIFY THAT THE COST TO INSTALL THE WATER DISTRIBUTION SYSTEM AND ON-SITE SEWAGE FACILITIES, DISCUSSED ABOVE, ARE AS FOLLOWS:

WATER FACILITIES - THESE FACILITIES FULLY CONSTRUCTED, WITH THE INSTALLATION OF WATER METERS, WILL COST A GRAND TOTAL OF \$ 62,500.00
SEWAGE FACILITIES - SEPTIC SYSTEM IS ESTIMATED TO COST \$1,500.00 PER LOT (ALL INCLUSIVE), FOR A TOTAL OF \$ 78,000.00 FOR THE ENTIRE SUBDIVISION.

FINAL WATER AND SEWER ENGINEERING REPORT IN SPANISH
PROVISION DE AGUA: DESCRIPCION, GASTOS Y FECHA DE INICIO
LA SUBDIVISION DE SIENNA RIDGE SUBDIVISION RECIBIRA SU PROVISION DE AGUA DE NORTH ALAMO WATER SUPPLY. EL DUENO DE LA SUBDIVISION Y LA COMPANIA AGUA N.A.W.S.C., HAN FIRMADO UN CONTRATO POR EL CUAL LA SUBDIVISION RECIBIRA SU PROVISION DE AGUA POR LOS PROXIMOS 30 ANOS. N.A.W.S.C. HA PRESENTADO DOCUMENTACION PARA DEMOSTRAR A LARGO PLAZO LA CANTIDAD Y CALIDAD DE AGUA ACCESIBLE PARA SERVIR EL FUTURO DESARROLLO DE LA SUBDIVISION.
EL SISTEMA DE PROVISION DE AGUA PARA LA SUBDIVISION DE SIENNA SUBDIVISION CONSISTE DE UN CONDUCTO DE AGUA EXISTENTE DE 8 PULGADAS DE DIAMETRO QUE PASA POR EL LAO ESTE DEL DERECHO DE VIA (RIGHT-OF-WAY) DE LA CARRETERA MILE 6 1/2 WEST ROAD Y SE INSTALARA UNA LINE DE 8 PULGADAS DE AGUA, 10 SERVICIOS DOBLES Y 2 SERVICIOS DE 3/4 DE PULGADA SENCILLOS Y 4 HYDRANTES DE AGUA
PARA ESTA SUBDIVISION Y EL MEDIDOR MECANICO DE AGUA A UN COSTO TOTAL DE \$45,000.00
EL DUENO DE LA SUBDIVISION TAMBIEN LE HA PAGADO A N.A.W.S.C. \$17,500.00 POR LOS LOTES QUE CUBRE EL COSTO DEL MEDIDOR MECANICO DE AGUA PARA CADA LOTE. ESTE PRECIO INCLUYE EL COSTO DE LA INSTALACION DEL MEDIDOR Y LOS GASTOS DE CONEXION, CUANDO EL DUENO DEL LOTE SOLICITE EL MEDIDOR DE AGUA. LA COMPANIA DE N.A.W.S.C. LO INSTALARA SIN COSTO ALGUNO AL DUENO DE LA SUBDIVISION. EL SISTEMA DE AGUA ESTARA EN FUNCIONAMIENTO COMPLETO ANTES O EN LA FECHA, EN LA CUAL LA SUBDIVISION SEA REGISTRADA EN EL CONDADO DE HIDALGO.
DRENAJE: DESCRIPCION, GASTOS Y FECHA DE INICIO PARA FACILITAR EL DRENAJE PARA LA SUBDIVISION.
SE INSTALARA UNA FOSA SEPTICA EN CADA SOLAR. ESTA FOSA SEPTICA CONSISTE DE UN TANQUE SEPTICO DE MODELO DUAL Y DE UN CAMPO DE DRENAJE PARA EL SOLAR. GUSTAVO CHAPA AUTOR DE ESTE DOCUMENTO HA EVALUADO EL AREA DONDE SE ENCUENTRA LA SUBDIVISION Y HA PREPARADO UN REPORTE QUE CONCLUYE QUE ESTE TERRENO ES ADECUADO PARA ESAS FOSAS SEPTICAS (OSSF). EL REPORTE FUE APROBADO POR EL DEPARTAMENTO DE SALUBRIDAD DEL CONDADO DE HIDALGO (HIDALGO COUNTY HEALTH DEPARTMENT) SEGUN EL REPORTE. CADA LOTE EN LA SUBDIVISION MIDE MEDIO ACRE. SE HICIERON DOS EXCAVACIONES DE EVALUACION EN LOS LUGARES OPUESTOS EN LA SUBDIVISION EXCAVACIONES ADICIONALES NO FUERON NECESARIAS PORQUE EL TERRENO EN ESTA AREA ES SIGNIFICATIVAMENTE UNIFORME) EL TERRENO ES UNIFORME (TERRENO ARCILLOSO Y SUELO FRANCO) Y SE EXTIENDE A 60 PULGADAS BAJO TODAS LAS EXCAVACIONES PROPUESTAS. NO EXISTE EVIDENCIA DE AGUA 24 PULGADAS MAS ARRIBA DE LO MAS BAJO DE LAS EXCAVACIONES PROPUESTAS. EL AGUA EN ESTA AREA FLUYE BIEN.
EL COSTO TOTAL PARA LA INSTALACION DE LOS SISTEMAS INDIVIDUAL DE FOSAS SEPTICAS PARA LA SUBDIVISION ES DE \$78,000.00 INCLUYENDO EL COSTO DEL PERMISO REQUERIDO Y LICENCIA. EN ESTOS MOMENTOS NINGUNA FOSA SEPTICA HA SIDO INSTALADA EN EL PROCESO DE LA APROVACION FINAL.
EN CUALQUIER MOMENTO DESPUES QUE EL TERRENO SEA VENDIDO, EL COMPRADOR PUEDE INICIAR LA INSTALACION DE UN SISTEMA SEPTICO ESCRIBIENDO O LLAMANDO AL DUENO DE LA SUBDIVISION Y ENTONCES ARCHIVANDO EN EL DEPARTAMENTO DE SALUD DEL CONDADO DE HIDALGO UNA APLICACION PARA UN PERMISO DE CONSTRUIR PARA UN SISTEMA SEPTICO. LAS FOSAS SEPTICAS DEBEN DE ESTAR INSTALADAS ANTES QUE EL CONDADO DE HIDALGO PUEDA APROBAR LA AUTORIZACION DE LUZ Y AGUA.

CERTIFICACION:
CON MI FIRMA, CERTIFICO QUE LOS SERVICIOS Y SISTEMAS DE AGUA Y DE DRENAJE, DESCRITOS EN ESTE DOCUMENTO CUMPLEN CON LAS MODEL SUBDIVISION RULES (LAS REGLAS GOBERNANDO A LAS SUBDIVISIONES), ADOPTADAS EN LA SECCION 16.343 DEL TEXAS WATER CODE (CODIGO DE AGUA TEXAS). CERTIFICO QUE LOS GASTOS PARA INSTALAR LOS SISTEMAS DE AGUA Y DE DRENAJE SON:
AGUA: EL SISTEMA/SERVICIO DE AGUA SERA INSTALADO Y COMPLETAMENTE CONSTRUIDO MENOS EL MEDIDOR MECANICO DE AGUA QUE COSTARA UN TOTAL DE \$
DRENAJE: SE ESTIMA QUE LAS FOSAS SEPTICAS COSTARAN \$ 78,000.00 PARA TODA LA SUBDIVISION

PRINCIPAL CONTACTS:
NAME: ALBERT HANKS 502 E. EXPRESSWAY 83, SUITE G WESLACO, TEXAS, 78596 (956) 630-0218
OWNER: GUILLERMO A. ARRATIA 526 N. 5TH ST. DONNA, TX 78537 (956) 784-0218
ENGINEER: HOMERO GUTIERREZ 2600 SAN DIEGO MISSION, TX (956) 363-0988
SURVEYOR:

COST ESTIMATE:

STREET PAVING	\$ 118,500.00
WATER SUPPLY SYSTEM	\$ 62,500.00
SANITARY SEWER SYSTEM	\$ 78,000.00
DRAINAGE	\$ 62,418.00

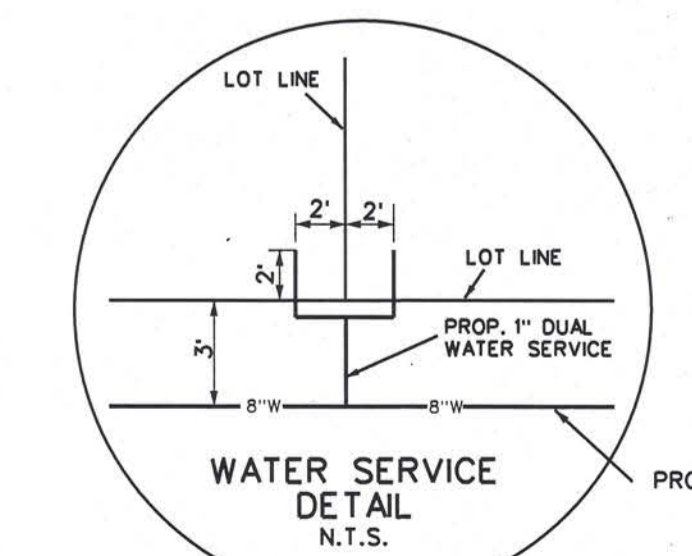

STATE OF TEXAS
COUNTY OF HIDALGO
BEFORE ME, THE UNDERSIGNED NOTARY PUBLIC, ON THIS DAY PERSONALLY APPEARED ALBERT HANKS PROVED TO BE THROUGH THEIR TEXAS SUBSCRIBED OF PUBLIC SAFETY DRIVER LICENSE TO BE THE PERSON WHOSE NAME IS TO THE FOREGOING INSTRUMENT, WHO, BEING BY ME DULY SWORN, DECLARED THAT THEIR STATEMENTS THEREIN ARE TRUE AND CORRECT AND ACKNOWLEDGED THAT THEY EXECUTED THE SAME FOR THE PURPOSES AND CONSIDERATION THEREBY EXPRESSED.
GIVEN UNDER MY HAND AND SEAL OF OFFICE THIS _____ DAY OF _____, 2022

OWNER: DIMANAGEMENT LLC
ALBERT HANKS - MANAGER OF DIMANAGEMENT, LLC
ADDRESS: 502 E. EXPRESSWAY 83, SUITE G WESLACO, TEXAS, 78596

STATE OF TEXAS
COUNTY OF HIDALGO
GUILLEMO A. ARRATIA
LICENSED PROFESSIONAL ENGINEER # 94001
526 N. 5TH ST.
DONNA, TEXAS, 78537

11/15/2022

SHEET No. 3 DATE OF PREPARATION: JULY 17, 2022

INDEX TO SHEET OF SIENNA SUBDIVISION

SHEET 1	HEADING: INDEX: LOCATION MAP AND ETJ; PRINCIPAL CONTACTS; PLAT WITH LOTS, STREETS, AND EASEMENT DESIGNATIONS; LEGAL DESCRIPTION (METES AND BOUNDS); SUBDIVISION CERTIFICATION; PLAT NOTES AND RESTRICTIONS; OWNER'S DEDICATION, CERTIFICATION, AND ATTESTATION; COUNTY APPROVAL CERTIFICATE; COUNTY CLERK'S RECORDING CERTIFICATE; HIDALGO COUNTY CERTIFICATE OF PLAT APPROVAL; DESCRIPTION OF LOCATION OF SUBDIVISION WITH RESPECT TO THE CITY OF A MUNICIPALITY AND DESIGNATE THE PRECINCT THE PROJECT IS SITUATED; H.C.C.D. CERTIFICATION; H.C.C.I.D. No. 9 CERTIFICATE OF APPROVAL; REVISION NOTES. H.C.H.D. CITY PLANNING AND CITY COMMISSION'S CERTIFICATION AND CITY COUNCIL CERTIFICATION
SHEET 2	WATER DISTRIBUTION AND ON-SITE SEWAGE FACILITY, ENGINEERING REPORT (ENGLISH AND SPANISH VERSION), INCLUDING DESCRIPTION OF WATER AND WASTE WATER AND ENGINEER'S CERTIFICATION (ENGLISH AND SPANISH VERSION); TYPICAL WATER SERVICE CONNECTION; OWNER'S DEDICATION, CERTIFICATION, AND ATTESTATION
SHEET 3	DRAINAGE REPORT INCLUDING DESCRIPTION OF DRAINAGE AND HOW IT WILL SERVE THIS DEVELOPMENT; MAP OF TOPOGRAPHY AND DRAINAGE; AND ENGINEER'S CERTIFICATION; REVISION NOTES; CONSTRUCTION DETAILS

NAIN ENGINEERING, L.L.C.
CONSULTING ENGINEER
526 N. 5TH STREET DONNA, TEXAS, 78537 FIRM NO. F-9050 PH. (956) 784-0218 E-MAIL: NAINENGINEERING@YAHOO.COM

SIENNA RIDGE SUBDIVISION

A 31.06 ACRE TRACT OF LAND OUT OF FARM
TRACT 216, WEST TRACT SUBDIVISION AS PER MAP RECORDED IN VOLUME 2,
PAGES 34-37, MAP RECORDS, HIDALGO COUNTY, TEXAS.

CONSTRUCTION DETAILS

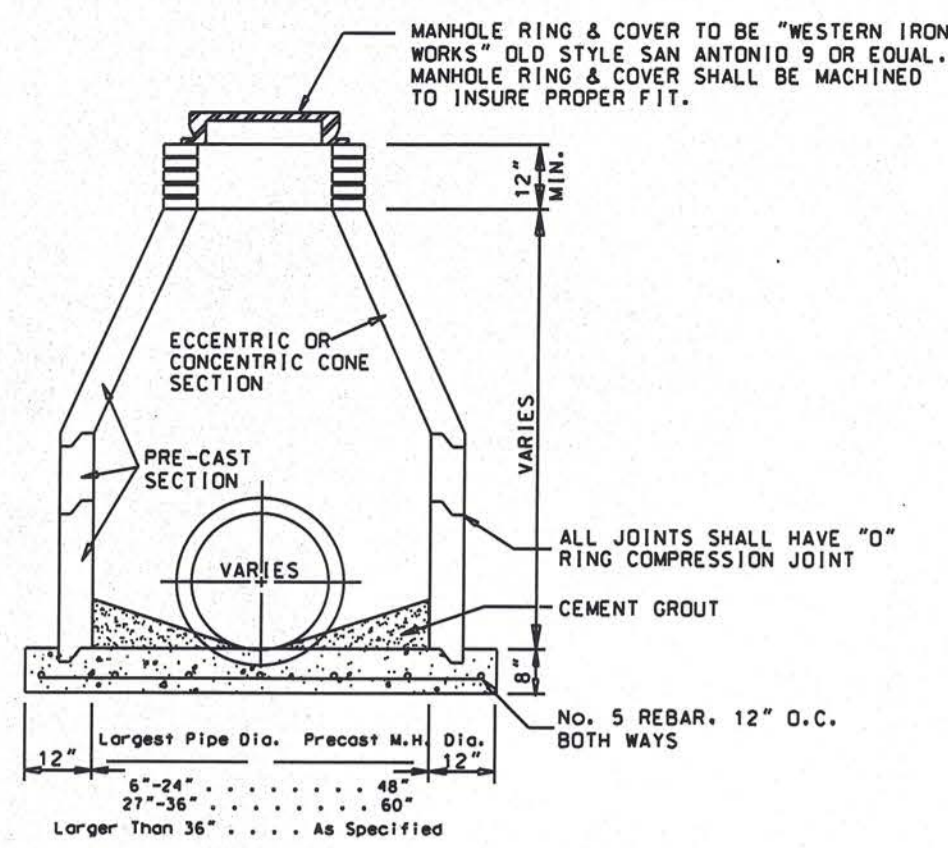

**STANDARD STORM SEWER
PRE-CAST CONCRETE MANHOLE**

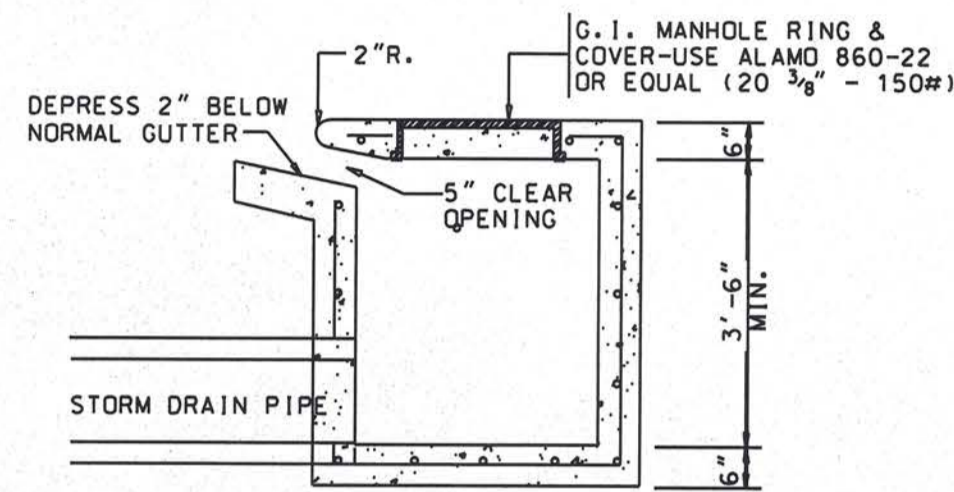

ALL STEEL TO BE NO. 4 BARS 12" SPACING
IN BOTH DIRECTIONS.

TYPE "A" INLET

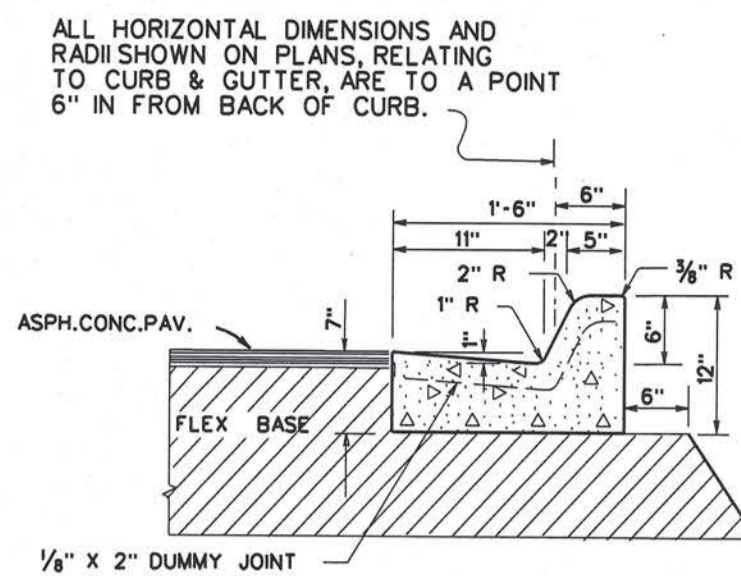

**CONC. CURB & GUTTER
TYPE "A" (BARRIER)**

NOTE:
EXPANSION JOINTS
1/2" PREMOLDED EXPANSION JOINT MATERIAL
SHALL BE INSTALLED WHERE CONC. CURB &
GUTTER ABUTS CONC. CURB OR WHERE CONC.
CURB & GUTTER OR CONC. CURB ABUT
INLETS AND/OR ANY OTHER LOCATIONS SPECIFIED
BY THE ENGINEER. MAX. SPACING = 105'

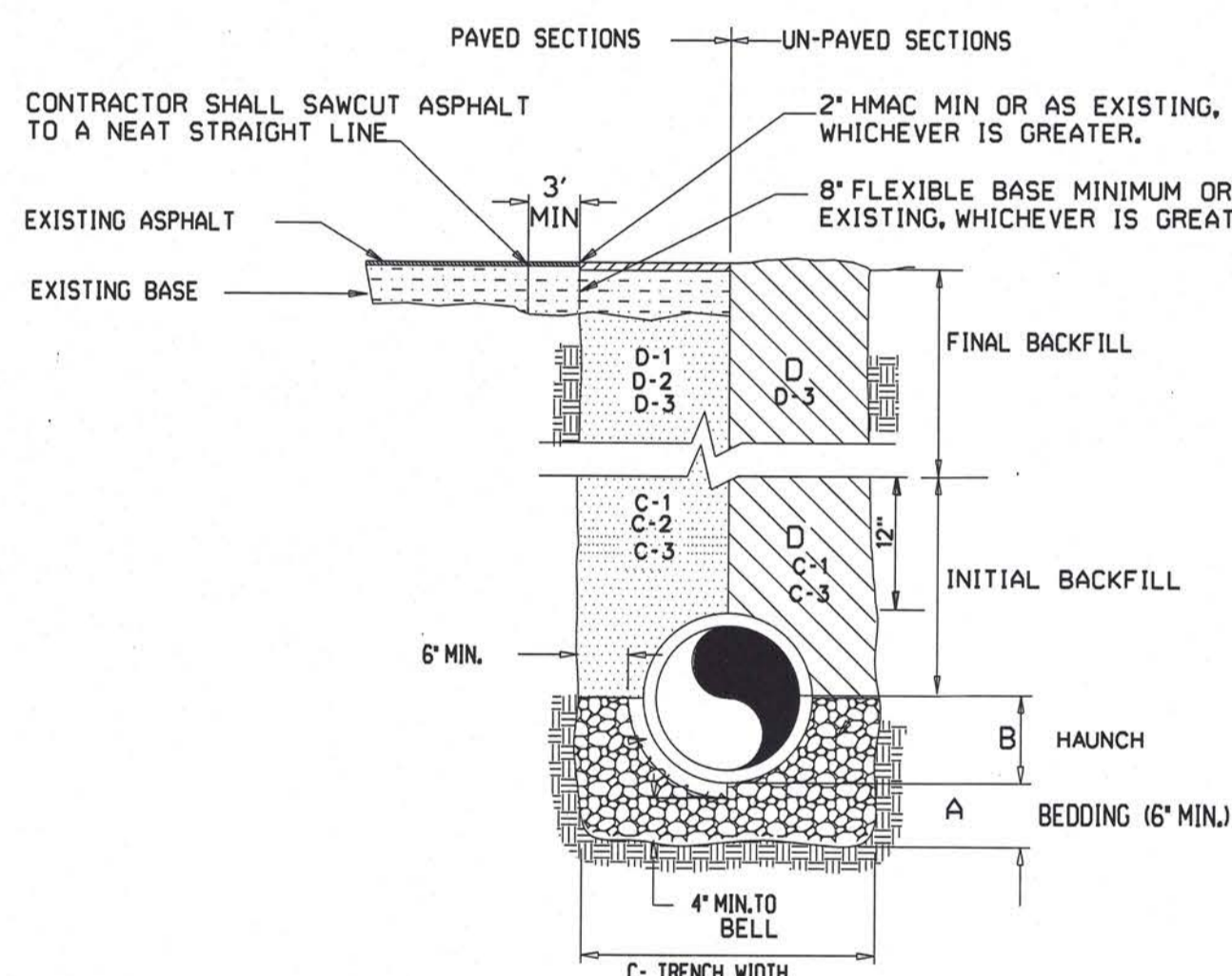

STORM TRENCH BEDDING AND BACKFILL DETAILS

- A. BEDDING FOR RCP CLASS III, HIGH PERFORMANCE POLYPROPYLENE OR CORRUGATED PVC STORM DRAIN PIPE - SAND AND/OR GRAVEL MIX BEDDING PLACED BEFORE PIPE IS LAD TO FLOW OF PIPE (MIN COMPACTED THICKNESS - 6") - PIT RUN GRAVEL 3/4" MAX SIZE
- B. HAUNCH FOR RCP CLASS III, HIGH PERFORMANCE POLYPROPYLENE OR CORRUGATED PVC STORM DRAIN PIPE - SHALL BE CLASS I OR CLASS II (ASTM D2321) BACKFILL MATERIAL COMPACTED TO 92% S.P.D. 8" LOOSE LIFTS, MECHANICAL COMPACTION.
- C. TRENCH WIDTH - SHALL BE BELL O.D. X 1.5 - 12" MINIMUM TRENCH WIDTH SHALL EQUAL STRUCTURE WIDTH - 4 FT THROUGHOUT THE HEIGHT OF THE STRUCTURE
- C-1. INITIAL BACKFILL FOR RCP CLASS III STORM DRAIN PIPE ON CITY STREETS, PAVING AREAS DRIVEWAYS, COUNTY ROADS AND UNPAVED AREAS - SHALL BE SOIL TYPE AI, A2, A3 WITH A MAXIMUM P.I. OF 19 (AASHTO M145) COMPACTED TO 92% S.P.D. 8" LOOSE LIFTS
- C-2. INITIAL BACKFILL FOR RCP CLASS III STORM DRAIN PIPE ON STATE MAINTAINED ROADWAYS - COMPACTED SAND/CEMENT STABILIZED BACKFILL WITH 7% PORTLAND CEMENT, COMPACTED TO 92% S.P.D. AS PER ASTM D4253 AND ASTM D698, 8" LOOSE LIFTS, MECHANICAL COMPACTION.
- C-3. INITIAL BACKFILL FOR HIGH PERFORMANCE POLYPROPYLENE OR CORRUGATED PVC STORM DRAIN PIPE - SHALL BE CLASS I OR CLASS II WITH A MAXIMUM P.I. OF 19 (ASTM D2321) BACKFILL MATERIAL COMPACTED TO 92% S.P.D. 8" LOOSE LIFTS, MECHANICAL COMPACTION.
- D. FINAL BACKFILL FOR RCP CLASS III, HIGH PERFORMANCE POLYPROPYLENE OR CORRUGATED PVC STORM DRAIN PIPE UNDER UNPAVED SECTIONS SHALL BE CLASS I, II, III OR IV COMPACTED TO 92% S.P.D. (12" LOOSE LIFTS, MECHANICAL COMPACTION).
- D-1. FINAL BACKFILL FOR RCP CLASS III, HIGH PERFORMANCE POLYPROPYLENE OR CORRUGATED PVC STORM DRAIN PIPE ON CITY STREETS, PARKING AREAS, DRIVEWAYS AND COUNTY ROADS SHALL BE SOIL TYPE AI, A2, A3 WITH A MAXIMUM P.I. OF 19 (AASHTO M 145) COMPACTED TO 92% S.P.D. 8" LOOSE LIFTS, MECHANICAL COMPACTION.
- D-2. FINAL BACKFILL FOR RCP CLASS III, HIGH PERFORMANCE POLYPROPYLENE OR CORRUGATED PVC STORM DRAIN PIPE ON STATE MAINTAINED ROADWAYS COMPACTED SAND/CEMENT STABILIZED BACKFILL WITH 7% PORTLAND CEMENT, COMPACTED TO 92% S.P.D. AS PER ASTM D4253 AND ASTM D 698, 8" LOOSE LIFTS, MECHANICAL COMPACTION
- D-3. FINAL BACKFILL FOR STRUCTURES (INLETS, MANHOLES, ETC.) STRUCTURES UNDER THE ROADWAY AND UP TO 5 FT BEYOND THE EDGE OF PAVEMENT/BACK OF CURB SHALL HAVE CLASS I OR CLASS II (ASTM D2321) OR SOIL TYPE AI, A2, OR A3 (AASHTO M 145) WITH A MAXIMUM P.I. OF 19 BACKFILL MATERIAL. STRUCTURES BEYOND 5 FT FROM E.O.P./B.O.C. SHALL HAVE CLASS I, II, III OR IV (ASTM D2321) BACKFILL MATERIAL. FOUNDATION PREPARATION (WELLPOINTS, MINIMUM 4" GRAVEL OR CEMENTS STABILIZATION, OR APPROVED STRUCTURES) SHALL BE REQUIRED WHEN TRENCH BOTTOM IS UNSTABLE. BACKFILL AT STRUCTURES SHALL BE PLACED IN UNIFORM LAYERS, MOISTENED AS REQUIRED TO APPROXIMATE OPTIMUM MOISTURE CONTENT AND COMPACTED TO 92% S.P.D. (USE RELATIVE DENSITY TEST PER ASTM D4253 AND ASTM D698) THE THICKNESS OF EACH LOOSE LAYER SHALL NOT EXCEED 8".

- NOTES:
1. MAXIMUM COVER SHALL BE IN ACCORDANCE WITH MANUFACTURER'S SPECIFICATIONS
2. FOR D-1, D-2 THE COMPACTION REQUIREMENT SHALL BE 92% S.P.D. WITHIN 12 IN
3. FOR PAVED SECTIONS THE ABOVE REQUIREMENTS SHALL BE APPLY WHEN ANY PART OF THE TRENCH WIDTH IS WITHIN 5 FT FROM E.O.P./B.O.C.
4. THE ABOVE REQUIREMENTS SHALL APPLY TO UTILITY PIPELINES AND ANY UTILITY STRUCTURES

REVISION NOTES			
No.	SHEET	REVISION	DATE APPROVED

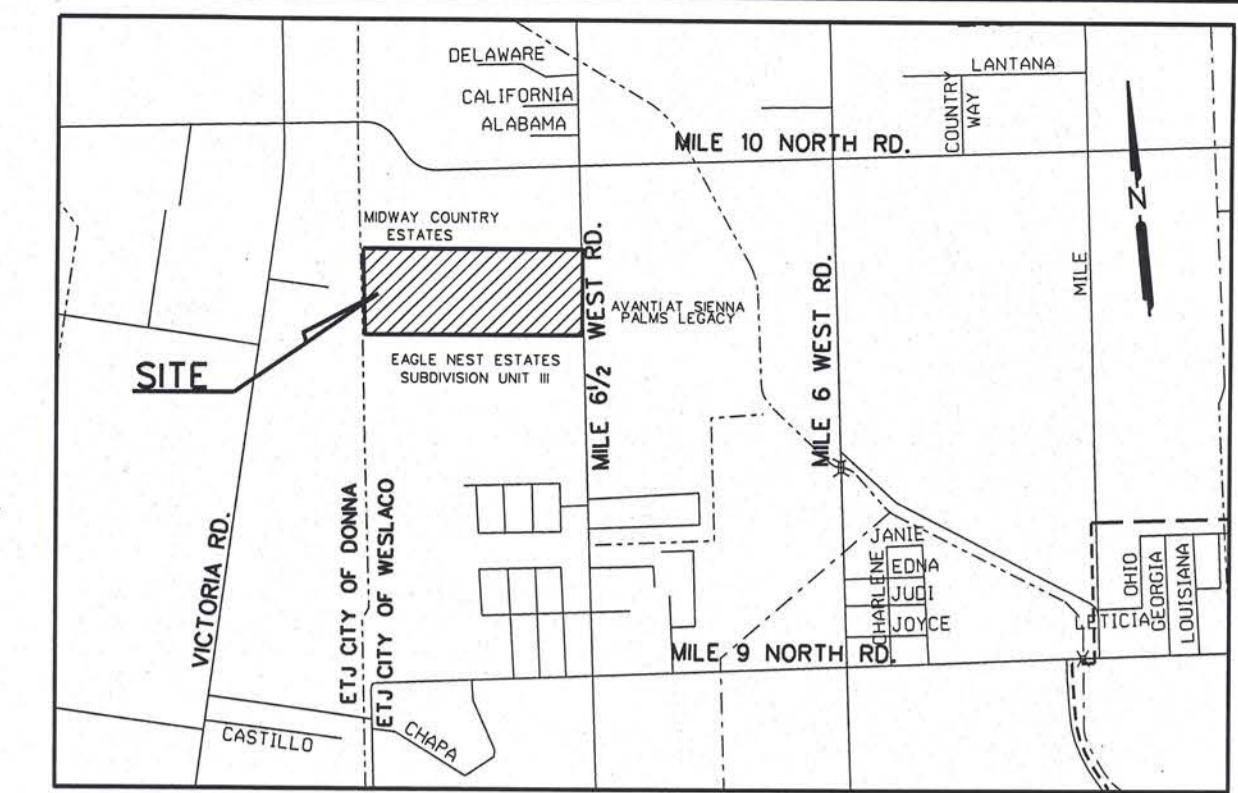

LOCATION MAP SCALE: 1" = 1000'

LOCATION OF SUBDIVISION WITH RESPECT TO THE EXTRATERRITORIAL JURISDICTION OF A MUNICIPALITY:
SIENNA RIDGE SUBDIVISION IS LOCATED WITHIN HIDALGO COUNTY PRECINCT NO. 1 IN THE CENTRAL EAST OF HIDALGO COUNTY ON THE WEST SIDE OF MILE 5 1/2 WEST ROAD 1050.78 FEET SOUTH OF MILE 10 NORTH ROAD. THE ONLY NEARBY MUNICIPALITY IS THE CITY OF WESLACO ACCORDING TO THE MAP IN THE OFFICE OF THE SECRETARY OF THE CITY OF WESLACO (POPULATION 37,791/2015 CENSUS). SIENNA SUBDIVISION LIES APPROXIMATELY 1.1 MILES FROM THE CITY LIMITS OF WESLACO AND LIES WITHIN THE CITY'S 3.5 MILE EXTRATERRITORIAL JURISDICTION (ETJ) UNDER LOCAL GOVERNMENT CODE § 42.021

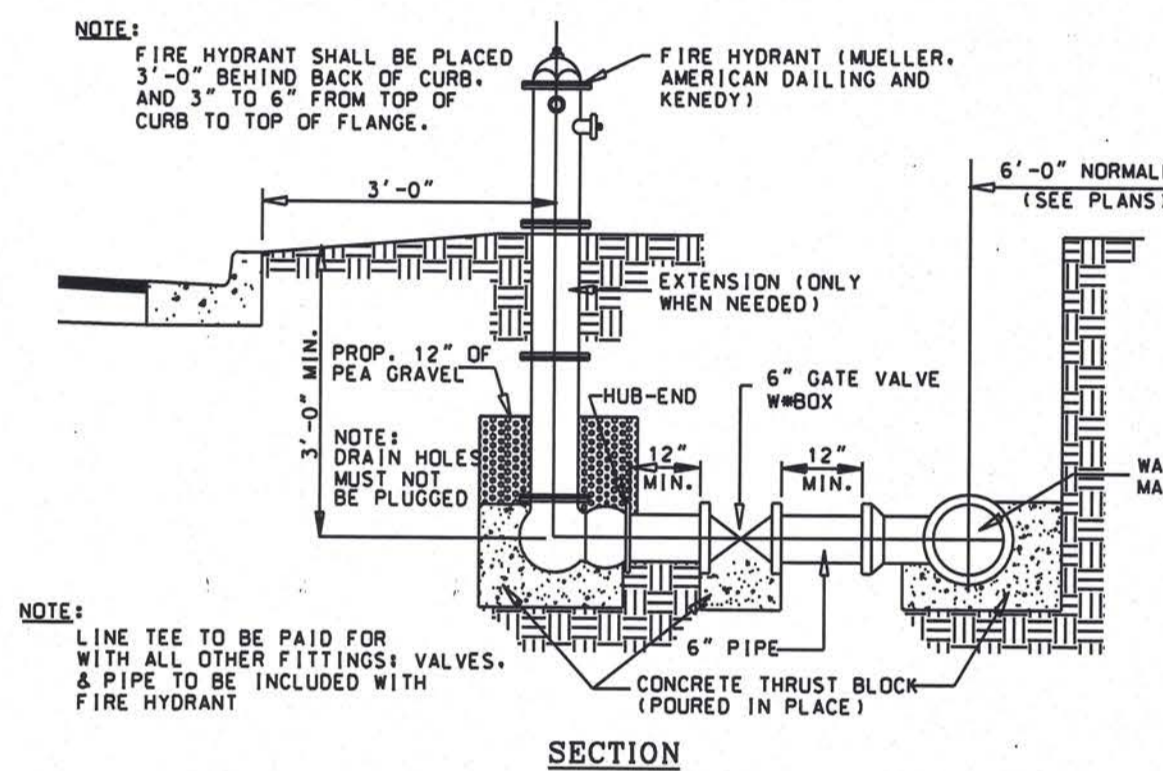

SECTION

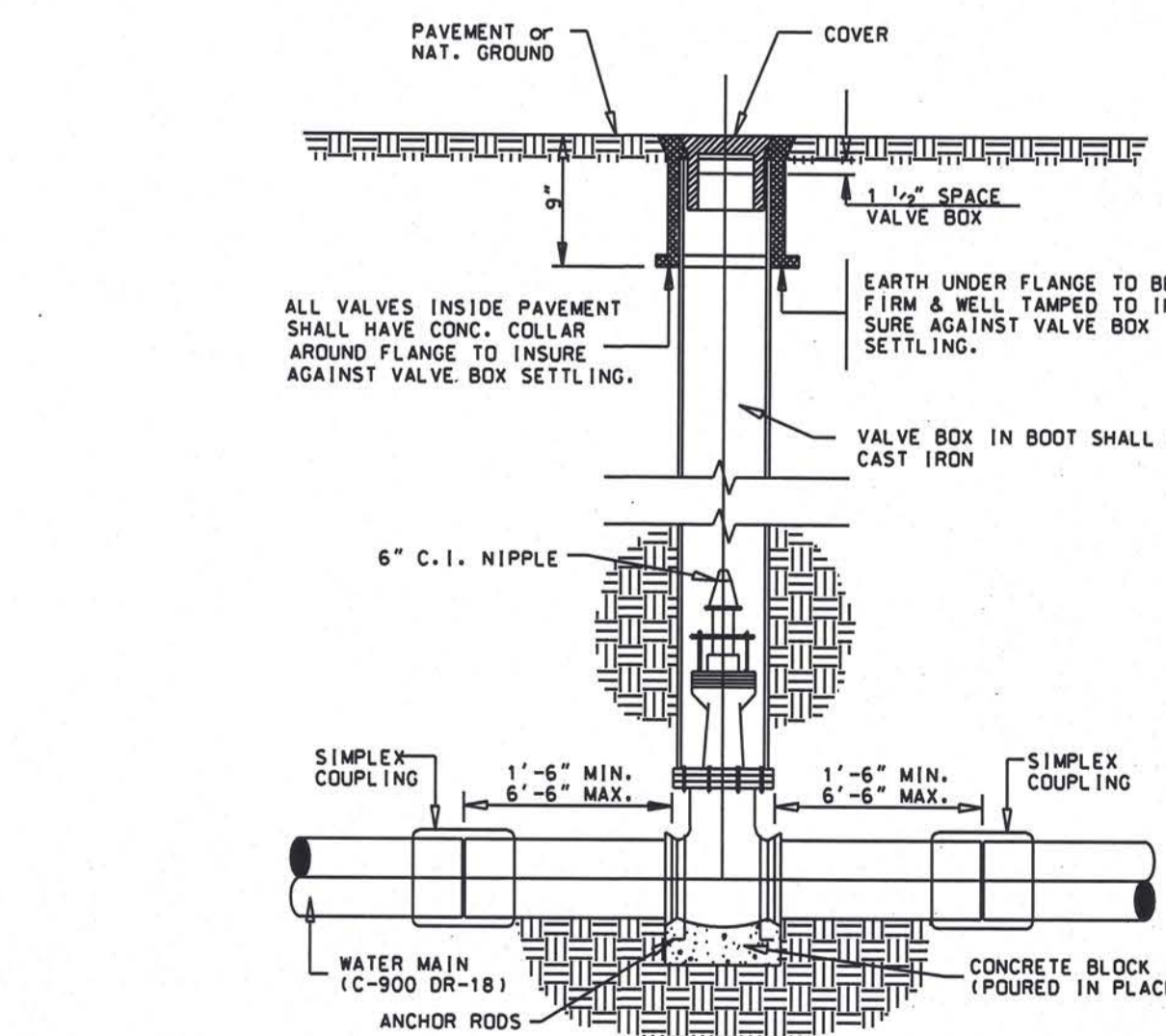

TYPICAL VALVE and VALVE BOX INSTALLATION

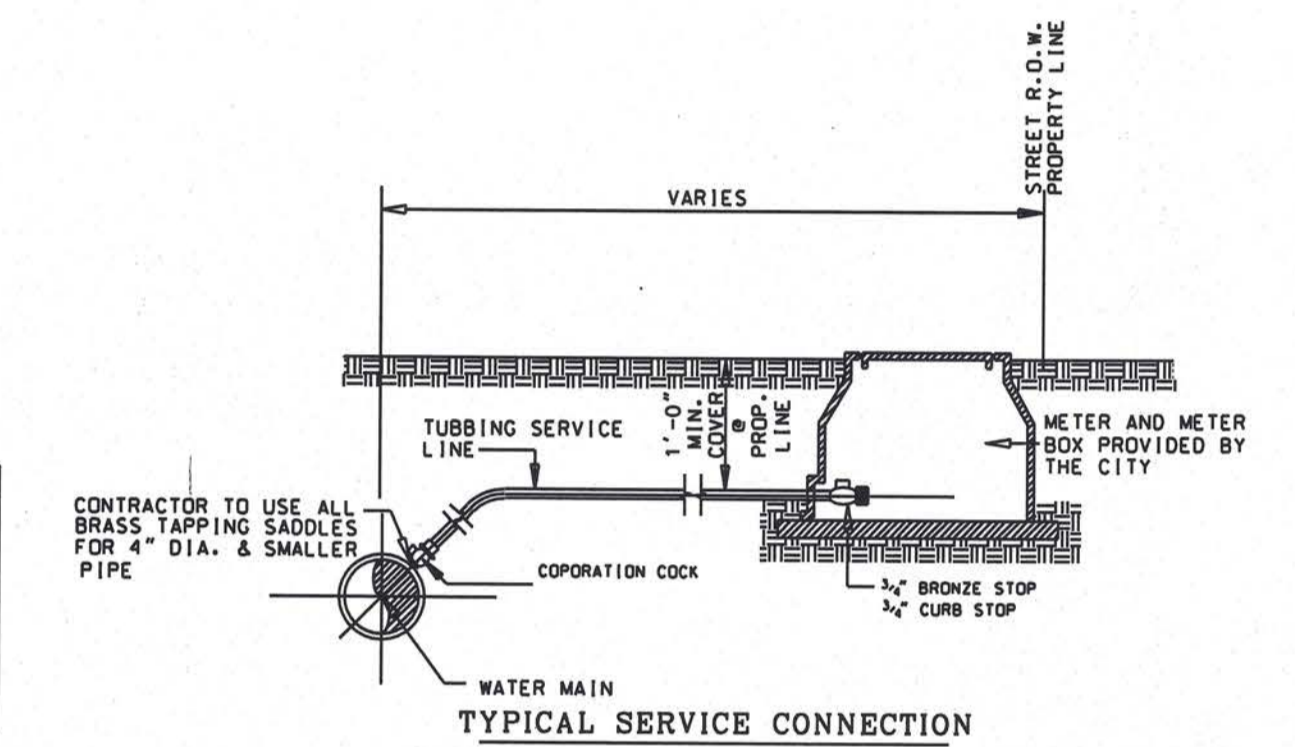

TYPICAL SERVICE CONNECTION

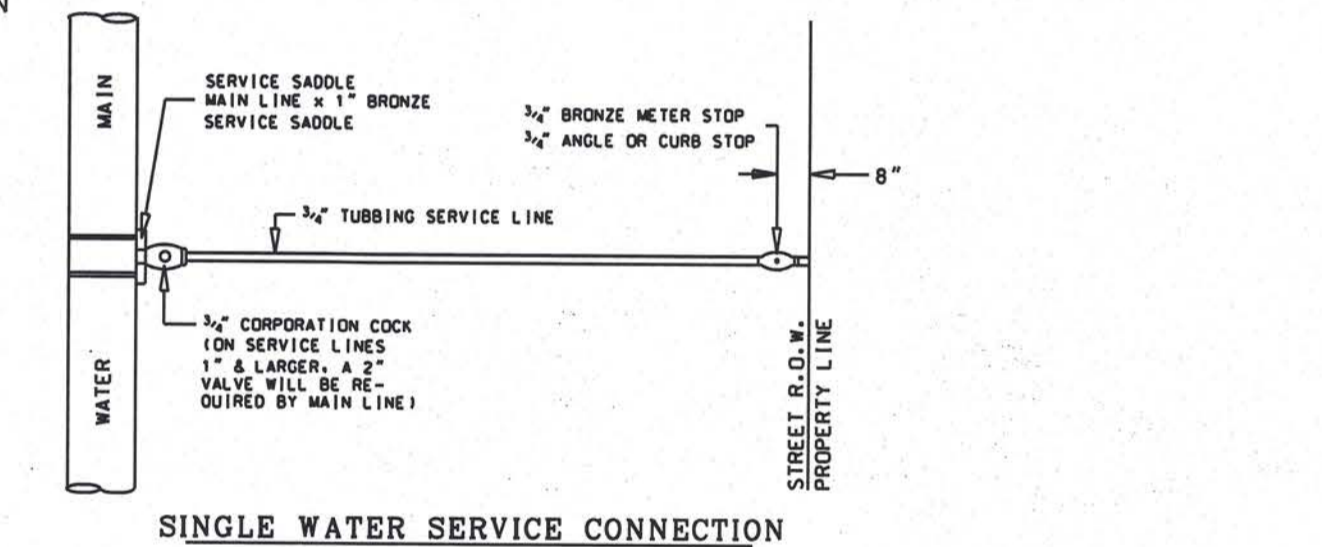

SINGLE WATER SERVICE CONNECTION



SHEET No. 5

INDEX TO SHEET OF SIENNA RIDGE SUBDIVISION	
SHEET 1	HEADING; INDEX; LOCATION MAP AND ETJ; PRINCIPAL CONTACTS; PLAT WITH LOTS, STREETS, AND EASEMENT DESIGNATIONS; LEGAL DESCRIPTION (METES AND BOUNDS); SURVEYOR'S AND ENGINEER'S CERTIFICATION; PLAT NOTES AND RESTRICTIONS; OWNER'S DEDICATION, CERTIFICATION, AND ATTESTATION; COUNTY APPROVAL CERTIFICATE; COUNTY CLERK'S RECORDING CERTIFICATE; HIDALGO COUNTY CERTIFICATE OF PLAT APPROVAL; DESCRIPTION OF LOCATION OF SUBDIVISION WITH RESPECT TO THE ETJ OF A MUNICIPALITY AND DESIGNATE THE PRECINCT THE PROJECT IS SITUATED; H.C.C.D. CERTIFICATION; H.C.C.I.D. No. 9 CERTIFICATE OF APPROVAL; REVISION NOTES - H.C.C.D. CITY PLANNING AND CITY COMMISSION'S CERTIFICATION AND CITY COUNCIL CERTIFICATION
SHEET 2	WATER DISTRIBUTION AND ON-SITE SEWAGE FACILITY, ENGINEERING REPORT (ENGLISH AND SPANISH VERSION); INCLUDING DESCRIPTION OF WATER AND WASTE WATER AND ENGINEER'S CERTIFICATION (ENGLISH AND SPANISH VERSION); TYPICAL WATER SERVICE CONNECTION; OWNER'S DEDICATION, CERTIFICATION, AND ATTESTATION
SHEET 3	DRAINAGE REPORT INCLUDING DESCRIPTION OF DRAINAGE AND HOW IT WILL SERVE THIS DEVELOPMENT; MAP OF TOPOGRAPHY AND DRAINAGE, AND ENGINEER'S CERTIFICATION; REVISION NOTES; CONSTRUCTION DETAILS

NAIN ENGINEERING, L.L.C.
CONSULTING ENGINEER

526 N. 5TH STREET DONNA, TEXAS. 78537 FIRM NO. F-9050 PH. (956) 784-0218 E-MAIL: NAINENGINEERING@YAHOO.COM