



**Planning
Department**

Anthony Uresti
Director of Planning

Main Office

2818 S. Business Hwy 281
Edinburg, Texas 78539
Phone (956) 318-2840

Precinct No. 1 Substation

1900 Joe Stephens Ave. Ste. A
Weslaco, TX 78596
Phone (956) 968-4734

Precinct No. 3 Substation

2401 N. Moorefield Road
Mission, Texas 78572
Phone (956) 205-7045

PIPELINE AND UTILITY PERMIT APPLICATION PACKET

THE STATE OF TEXAS

COUNTY OF HIDALGO

PRECINCT _____

**APPLICATION AND AGREEMENT FOR PIPELINE OR
UTILITY PERMIT**

Date: 2/19/24

Spectrum 1907350/EM19E (hereinafter referred to as "Applicant") does hereby make application to the Hidalgo County through the Hidalgo County Planning Department (hereinafter referred to as "HCPD") to construct, maintain and repair pipelines or utilities across the easements, right-of-ways, property or property interest as described below.

Information required:

1. Name, Address and Phone number of Applicant:

Robert Martinez 1-956-535-3264

1514 South 77 Sunshine Strip suite 1 Harlingen, Texas 78550

2. Name, Address and Phone number of company or agency owning Pipeline or Utility (please indicate if same as Applicant):

Same as applicant

3. Name, Address and Phone number of operator of Pipeline or Utility (please indicate if same as Applicant):

Same as applicant

4. Name, Address and Phone number of contractor to install Pipeline or Utility:

Janie Mendoza 1-512-973-9702

Dcomm Inc. 1810 East Sugar Cane Weslaco, Texas 78596

Visit Hidalgo County Planning Department on the web at www.co.hidalgo.tx.us



**Planning
Department**

Anthony Uresti
Director of Planning

Main Office

2818 S. Business Hwy 281
Edinburg, Texas 78539
Phone (956) 318-2840

Precinct No. 1 Substation

1900 Joe Stephens Ave. Ste. A
Weslaco, TX 78596
Phone (956) 968-4734

Precinct No. 3 Substation

2401 N. Moorefield Road
Mission, Texas 78572
Phone (956) 205-7045

PIPELINE AND UTILITY PERMIT APPLICATION PACKET

5. Is this a common carrier pipeline or utility? If yes, please submit the Applicant's Texas Railroad Commission Form "T-4" or similar form designating the facility:

NA

6. Does Applicant have the Power of Eminent Domain?

NA

7. Will the product be carried for hire or by the owner of the goods?

NA

8. Name and Legal description of property owner requesting utility services if applicable:

Cardinal Hills

6613 Vista Bonita rd Edinburg Texas 78540

9. Type of utility work within county road right-of-way:

Bore Crossing Line Extension Along R.O.W. Other pole

10. Where is the origin of the line?

NA

11. Where is the destination of the line?

NA



**Planning
Department**

Anthony Uresti
Director of Planning

Main Office

2818 S. Business Hwy 281
Edinburg, Texas 78539
Phone (956) 318-2840

Precinct No. 1 Substation

1900 Joe Stephens Ave. Ste. A
Weslaco, TX 78596
Phone (956) 968-4734

Precinct No. 3 Substation

2401 N. Moorefield Road
Mission, Texas 78572
Phone (956) 205-7045

PIPELINE AND UTILITY PERMIT APPLICATION PACKET

12. Utility Crossing Coordinate X: 26.376034 Y: -98.075396
(NAD 83 Texas South FIPS 4205 feet)

13. Number and size of lines:

NA

14. Pressure (each line):

NA

15. Content (each line):

NA

16. Estimated date of installation of Pipeline or Utility:

As soon as the permit is issued.



Planning Department

Anthony Uresti
Director of Planning

Main Office

2818 S. Business Hwy 281
Edinburg, Texas 78539
Phone (956) 318-2840

Precinct No. 1 Substation

1900 Joe Stephens Ave. Ste. A
Weslaco, TX 78596
Phone (956) 968-4734

Precinct No. 3 Substation

2401 N. Moorefield Road
Mission, Texas 78572
Phone (956) 205-7045

PIPELINE AND UTILITY PERMIT APPLICATION PACKET

If requested permit is granted by HCPD, Applicant, in consideration thereof, agrees and binds itself as follows:

1. All pipelines or utilities herein will be horizontally placed within the right-of-way as determined by HCPD and at a minimum depth of five (5) feet below natural ground. Depth, horizontal, and vertical location shall be confirmed by HCPD Inspectors.
2. Location map, profile, and plans concerning the proposed pipeline or utility crossing will furnished with this application.
3. HCPD will be notified in writing ten days prior to the beginning date of construction under this permit.
4. Applicant will bear the entire expense of all future relocations of any pipelines or utilities should such relocation, at the sole discretion of the Hidalgo County Commissioners Court, be necessary for improvements, alteration, or maintenance of Hidalgo County's easement or property of interest.
5. Applicant will notify the HCPD at least 48 hours prior to covering work and or completion of its work and removal of its equipment from the job site to permit HCPD to make an inspection.
6. Upon notification by the HCPD, the Applicant will promptly repair or rectify any deficiency or condition caused by the Applicant's operations or installations under this permit. Applicant will leave easement in as near the same condition or better, in the HCPD's sole judgment, as it existed prior to the commencement of the operations under this permit.
7. Hidalgo County shall not be liable or responsible for, and shall be saved and held harmless by Applicant, and further shall be indemnified by Applicant, from and against any and all suits, actions, losses, damages, claims, or liability of any character, type, or description, including all expenses of litigation, court costs, attorney's fees, and engineering fees for injury or death to any person, or injury to any property, received or sustained by any person or persons or property, arising out of, or occasioned by, directly or indirectly, the performance of Applicant under this agreement, including claims and damages arising in part from the negligence of Hidalgo County.



Planning Department

Anthony Uresti
Director of Planning

Main Office

2818 S. Business Hwy 281
Edinburg, Texas 78539
Phone (956) 318-2840

Precinct No. 1 Substation

1900 Joe Stephens Ave. Ste. A
Weslaco, TX 78596
Phone (956) 968-4734

Precinct No. 3 Substation

2401 N. Moorefield Road
Mission, Texas 78572
Phone (956) 205-7045

PIPELINE AND UTILITY PERMIT APPLICATION PACKET

It is the expressed intent of the parties to this agreement that the indemnity provided for in this section is extended by Applicant to indemnify and protect Hidalgo County from the consequences of Hidalgo County's own negligence, whether that negligence is the sole or contributory cause of the resultant injury death, or damage.

Applicant further agrees to defend, at its own expense, with attorneys acceptable to Hidalgo County and on behalf of Hidalgo County, and in the name of Hidalgo County, any claim or litigation brought against Hidalgo County in connection with any such injury, death or damage.

Before construction is begun on such pipeline or utility crossings, Applicant will furnish to the HCPD a certificate of insurance (or other security approved by the HCPD) payable to Hidalgo County and protecting Hidalgo County (as an additional named insured) against any claims for personal injuries or damages to property resulting from the operations of Applicant, its agents, servants, employees, and contractors under this permit. Insurance is to be supplied in accordance with the attached Schedule A.

8. Hidalgo County makes no warranties, expressed or implied, in the granting of this permit; nor does Hidalgo County purport to grant any property interest or exclusive privileges whatsoever by granting such permit. It is specifically understood that Hidalgo County is not the agent for, nor does it act for, the fee owners or any persons or entities having any right, or title to possession of the land upon which Hidalgo County's easement or other property interest is located. Furthermore, in granting this permit Hidalgo County makes no representation or warranty that it has any property interest, including, but not limited to, an easement or right of way, in the land upon which Applicant constructs, maintains, repairs, or modifies the pipelines or utilities, made the subject of this application, nor does Hidalgo County make any representation or warranty as to the validity, quality or extent of such property interest, if any. Applicant acknowledges its understanding that Hidalgo County in granting this permit, does not convey or grant to Applicant any rights, title or interest for which is has no legal authority to grant or convey.
9. Applicant binds itself to comply with all federal, state, and local laws or regulations and will obtain all necessary permits from all local and federal agencies required by law before installation or construction is begun.



Planning Department

Anthony Uresti
Director of Planning

Main Office

2818 S. Business Hwy 281
Edinburg, Texas 78539
Phone (956) 318-2840

Precinct No. 1 Substation

1900 Joe Stephens Ave. Ste. A
Weslaco, TX 78596
Phone (956) 968-4734

Precinct No. 3 Substation

2401 N. Moorefield Road
Mission, Texas 78572
Phone (956) 205-7045

PIPELINE AND UTILITY PERMIT APPLICATION PACKET

10. Applicant will install its pipelines and utilities in a manner and location as shown in the plans and specifications filed with HCPD in support of this application for permit. Hidalgo County Planning Department's representative may at any time make such inspection as such engineer or other representation may deem necessary to assure that the construction of the pipeline or utilities is in accordance with the plans and specifications submitted, and said engineer or representative shall have the right to temporarily suspend Applicant's work if necessary, while such inspection is being made. Should Applicant not install the pipelines or utilities in accordance with the terms and conditions of this permit, Applicant agrees that Hidalgo County shall have the right to require, at Applicant's expense, the removal of the pipelines and utilities and its replacement in conformance to said plans and specifications and conditions of this permit. Hidalgo County may revoke this permit and suspend all work hereunder if it is determined by Hidalgo County that the pipelines or utilities are not being installed in accordance with such plans and specifications and conditions of this permit. The suspension or revocation of this permit shall not be a basis for a claim for damages against Hidalgo County.
11. Except in emergency situations where it is necessary to protect life and property, Applicant will not make any change, modification, or alteration in or to the pipelines or utilities without first securing a new or amended permit from Hidalgo County prior to the making of any such change. Applicant will maintain the pipelines or utilities hereby authorized in good and safe condition, and in accordance with plans, specifications, and this permit.
12. Applicant agrees to pay HCPD a permit fee to cover administrative costs in the amount of **\$500.00**, plus a reimbursement to HCPD for any necessary engineering fees which may be incurred for the study and processing of the Application. This fee will permit a single pipeline or utility to be within County right-of-way. Applicant further agrees to pay an additional fee of **\$500.00** for each additional line included in permit application at the same location; however, more than one location may be included in a single application.

Requests to lay additional line or lines, not included in an initial permit application, must be made by separate application, with new permit fees paid accordingly and support data provided.



Planning Department

Anthony Uresti
Director of Planning

Main Office

2818 S. Business Hwy 281
Edinburg, Texas 78539
Phone (956) 318-2840

Precinct No. 1 Substation

1900 Joe Stephens Ave. Ste. A
Weslaco, TX 78596
Phone (956) 968-4734

Precinct No. 3 Substation

2401 N. Moorefield Road
Mission, Texas 78572
Phone (956) 205-7045

PIPELINE AND UTILITY PERMIT APPLICATION PACKET

Permit fees may be waived where Applicant is a state, county, municipality, or a special political subdivision.

13. The Applicant is allowed one hundred twenty days (120) from the granting of the permit to start construction of the pipelines or utilities crossings. Once started, the Applicant is allowed ninety (90) days to complete all work under such permit. All construction must be completed within two hundred ten (210) days from the date of issuance of permit. Upon application, extension of the time periods set forth in this paragraph may be granted by the Hidalgo County Commissioners Court. Such applications for extension must be received by HCPD at least thirty days before the expiration of the two hundred ten (210) days period. A new permit fee, in accordance with Paragraph 12 hereof, will be charged for each extension granted.

Construction of any pipeline or utility crossing will not begin until written approval has been given by HCPD.

14. All provisions of the Pipeline and Utility Permit Administration Policy of Hidalgo County, if any, and all amendments thereto, are hereby incorporated herein as part of the terms and conditions of this permit for all purposes.
15. Applicant warrants and represents that it has secured from all fee owners of the involved property an easement or other property rights to construct, repair or modify the pipeline or utility in the manner set forth herein.
16. This Pipeline and Utility Permit if granted by Hidalgo County is subject to any and all other requirements, specifications and conditions listed in Exhibit A attached hereto.
17. Hidalgo County requires all coordinates of all utility crossings. Horizontal datum to be in NAD 83 State Plane Texas South 4205 feet and vertical datum in NAVD 88 Geoid 12a.



**Planning
Department**

Anthony Uresti
Director of Planning

Main Office

2818 S. Business Hwy 281
Edinburg, Texas 78539
Phone (956) 318-2840

Precinct No. 1 Substation

1900 Joe Stephens Ave. Ste. A
Weslaco, TX 78596
Phone (956) 968-4734

Precinct No. 3 Substation

2401 N. Moorefield Road
Mission, Texas 78572
Phone (956) 205-7045

PIPELINE AND UTILITY PERMIT APPLICATION PACKET

18. This permit constitutes the entire agreement between the parties with regard to the subject matter hereof, and all prior agreements, representations, and negotiations between the parties regarding the subject matter are hereby superseded. This permit shall not be altered or amended except by an agreement in writing executed by the parties hereto.

19. Applicant warrants and represents that its undersigned representative has full authority to bind Applicant to the terms and conditions of the foregoing Application and Agreement for Pipeline or Utility Permit.

DATED this 19th day of February, 2024.

Robert Martinez
(Name of Applicant – Printed or Typed)

By: Robert Martinez
Signature

Title: Construction Coordinator

STATE OF TEXAS
COUNTY OF HIDALGO

SUBSCRIBED AND SWORN TO before me the Applicant,
Robert Martinez, on this 19th day of February, 2024,
to which witness my hand and seal of office.

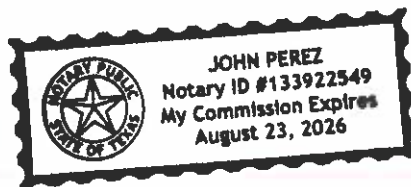

[Signature]
Notary Public for the State of Texas

My Commission Expires: August 23, 2024



**Planning
Department**

Anthony Uresti
Director of Planning

Main Office

2818 S. Business Hwy 281
Edinburg, Texas 78539
Phone (956) 318-2840

Precinct No. 1 Substation

1900 Joe Stephens Ave. Ste. A
Weslaco, TX 78596
Phone (956) 968-4734

Precinct No. 3 Substation

2401 N. Moorefield Road
Mission, Texas 78572
Phone (956) 205-7045

PIPELINE AND UTILITY PERMIT APPLICATION PACKET

**APPROVAL OF APPLICATION BY
HIDALGO COUNTY PLANNING DEPARTMENT**

Came on for consideration this _____ day of _____,
20____. The above and foregoing Application for Pipeline and Utility
Permit, and after consideration of the same by the Hidalgo County
Commissioners Court, said Application and Agreement for Pipeline or
Utility Permit is hereby APPROVED.

HIDALGO COUNTY:

Richard F. Cortez, County Judge



Planning Department

Anthony Uresti
Director of Planning

Main Office

2818 S. Business Hwy 281
Edinburg, Texas 78539
Phone (956) 318-2840

Precinct No. 1 Substation

1900 Joe Stephens Ave. Ste. A
Weslaco, TX 78596
Phone (956) 968-4734

Precinct No. 3 Substation

2401 N. Moorefield Road
Mission, Texas 78572
Phone (956) 205-7045

PIPELINE AND UTILITY PERMIT APPLICATION PACKET

EXHIBIT A

(Please insert description of project location and supporting documents for proposed utility work)



SANTA CRUZ GARDENS

CASTILLO, ALEJANDRO & LETICIA
S1700-02-008-0007-00

8
BLOCK 8

MEZA, MARTHA
S1700-02-008-0008-00

6827 VISTA BONITA RD.
EDINBURG, TX 78542
HIDALGO COUNTY
APPRAISAL DIST. INFO:
PROPERTY ID: 277913
LEGAL DESCRIPTION:
SANTA CRUZ GARDENS UT
NO. 2 LOT 9 BLK 8 8.87AC GR
8.77AC NET
DEED DOCUMENT: 1472337

VILLANUEVA, JOEL JR.
S1700-02-008-0009-00

1
BLOCK 9

CHAPA, NANCY
S1700-02-009-0001-00

2
BLOCK 10

RENDON JULIAN
S1700-02-009-0001-10

SEE DETAIL "A"
SHEET 2

VISTA BONITA RD.

~ 1435' TO BRUSHLINE RD.

DUBE, DENNIS & BARBARA
S1700-02-011-0007-00

ROSA MARIA LEON
S1700-02-011-0009-00/-01

SANTA CRUZ GARDENS

8
BLOCK 11

1
BLOCK 10

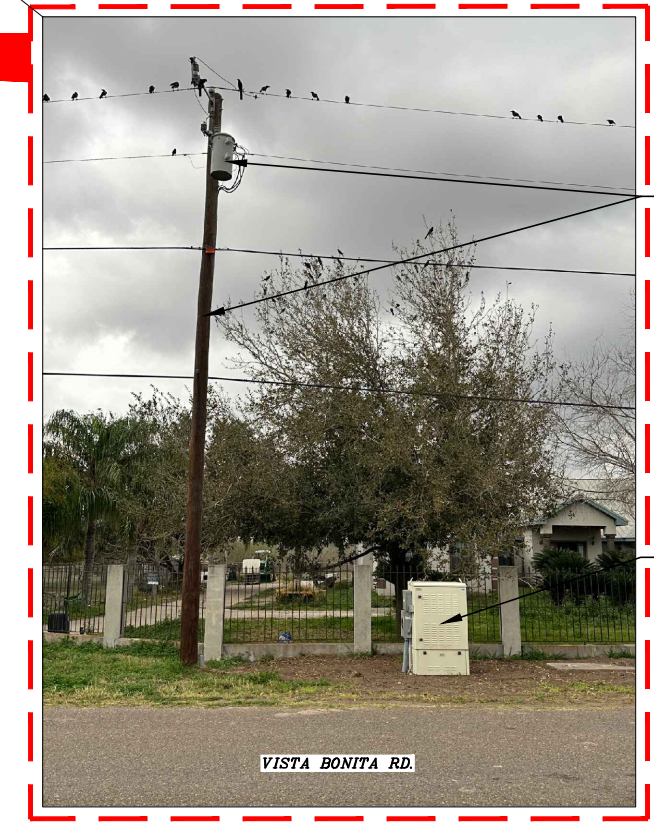
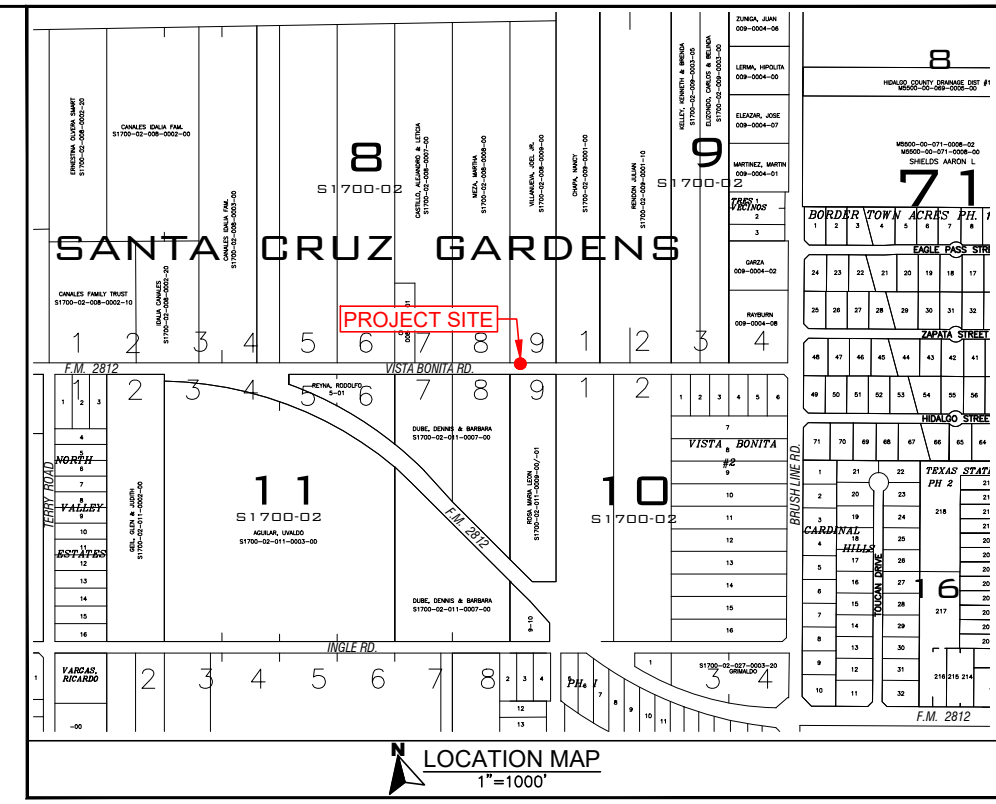

LAT: 26.376034° - LONG: -98.075396°
NEW SPECTRUM UNDERGROUND
POWER SUPPLY 3' SOUTH FROM
ROW & 12' NORTH FROM EOP

PROJECT NAME: SPECTRUM POWER SUPPLY AT CARDINAL HILLS SUBDIVISION		
ADDRESS: ALONG NORTH SIDE OF VISTA BONITA ROAD APPROX. 1435' WEST FROM BRUSHLINE ROAD		
PRISM #: 1907350	DATE: 2/17/2024	SCALE: 1"=100'
PAGE: 1 OF 3	CITY: EDINBURG	

LEGEND	
	EXIST. POWER POLE
	PROP. POWER POLE
	RIGHT OF WAY LINE
	EDGE OF PAVEMENT
	EDGE OF SIDEWALK
	RISER
	EXIST. PEDESTAL
	PROP. PEDESTAL
	EXIST. UNDERGROUND
	PROP. UNDERGROUND
	PROP. OVERLASH
	PROP. NEW BUILD



ABBREVIATIONS	
H.C.A.D.	HIDALGO COUNTY APPRAISAL DISTRICT
H.C.M.R.	HIDALGO COUNTY MAP RECORDS
PI:	PROPERTY IDENTIFICATION
PROP.	PROPOSED
EXIST.	EXISTING
ROW	RIGHT-OF-WAY
EOP	EDGE OF PAVEMENT
CL	CENTER LINE
SW	SIDEWALK
ST.	STREET
RD.	ROAD

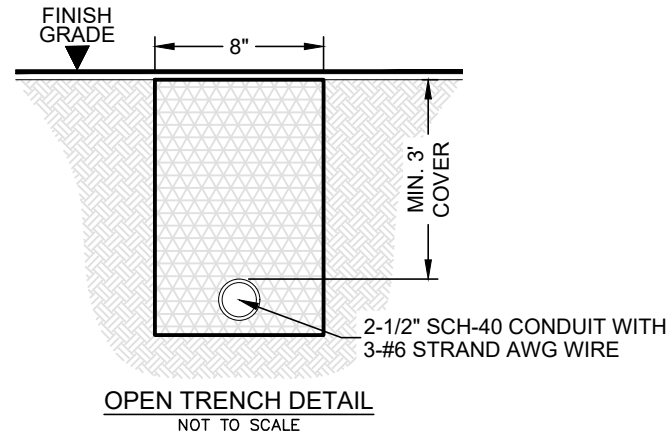

- NOTES:
1. ALL INFORMATION SHOWN ON THIS MAP HAVE BEEN GRAPHICALLY PLOTTED FROM FIELD OBSERVATION AND FROM AVAILABLE PUBLIC RECORDS. ALL MEASUREMENTS ARE APPROXIMATE, EXCAVATOR IS RESPONSIBLE TO FIELD VERIFY AND NOTIFY SPECTRUM SUPERVISOR IF THERE IS ANY CONFLICT BEFORE WORK STARTS.
 2. IT IS THE RESPONSIBILITY OF THE EXCAVATOR TO VERIFY AND FIELD LOCATE ANY AND ALL UNDERGROUND UTILITIES AND OBSTRUCTIONS PRIOR TO EXCAVATION. IT SHALL BE THE EXPENSE OF THE EXCAVATOR FOR ANY AND ALL DAMAGES INCURRED.

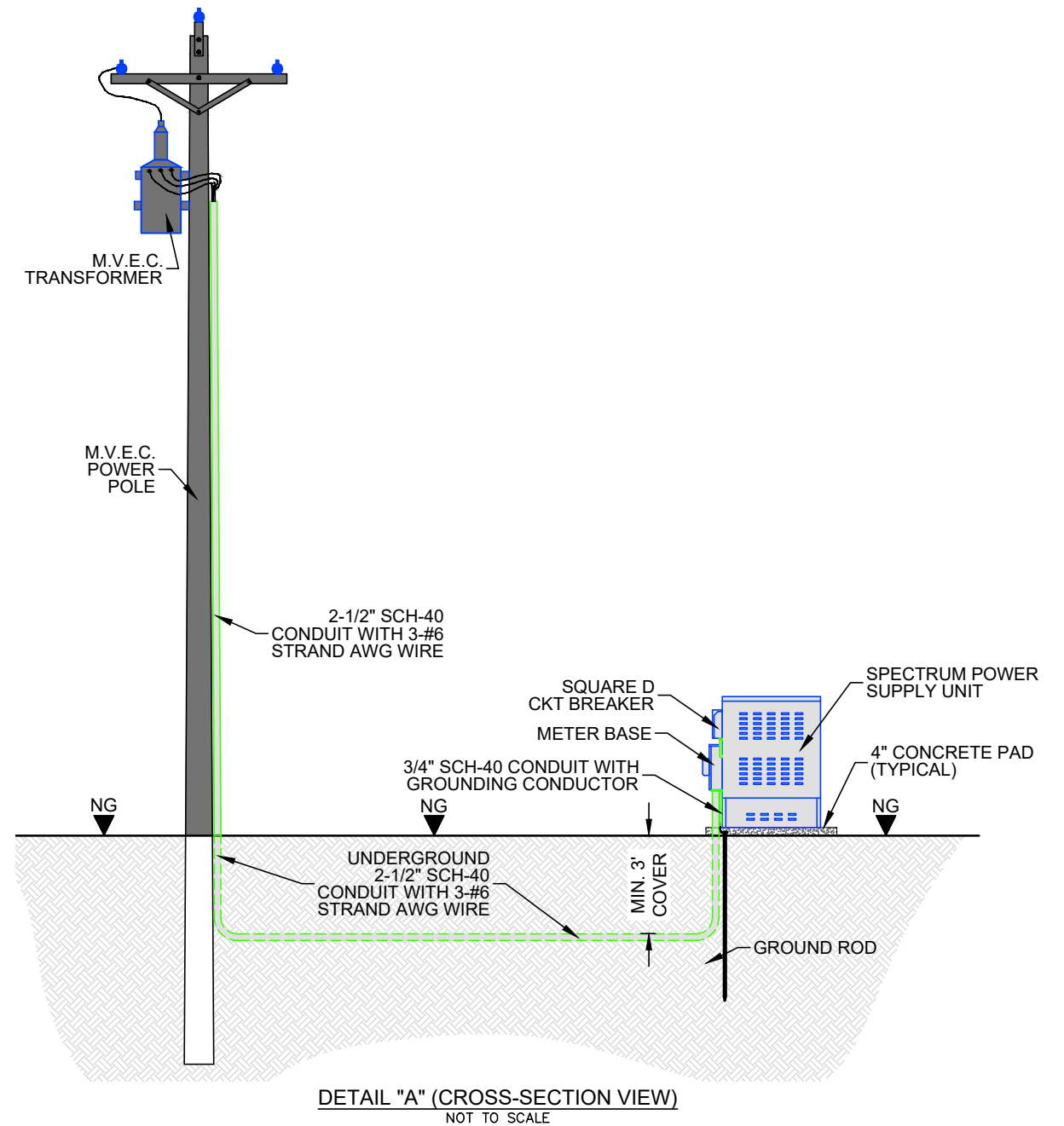
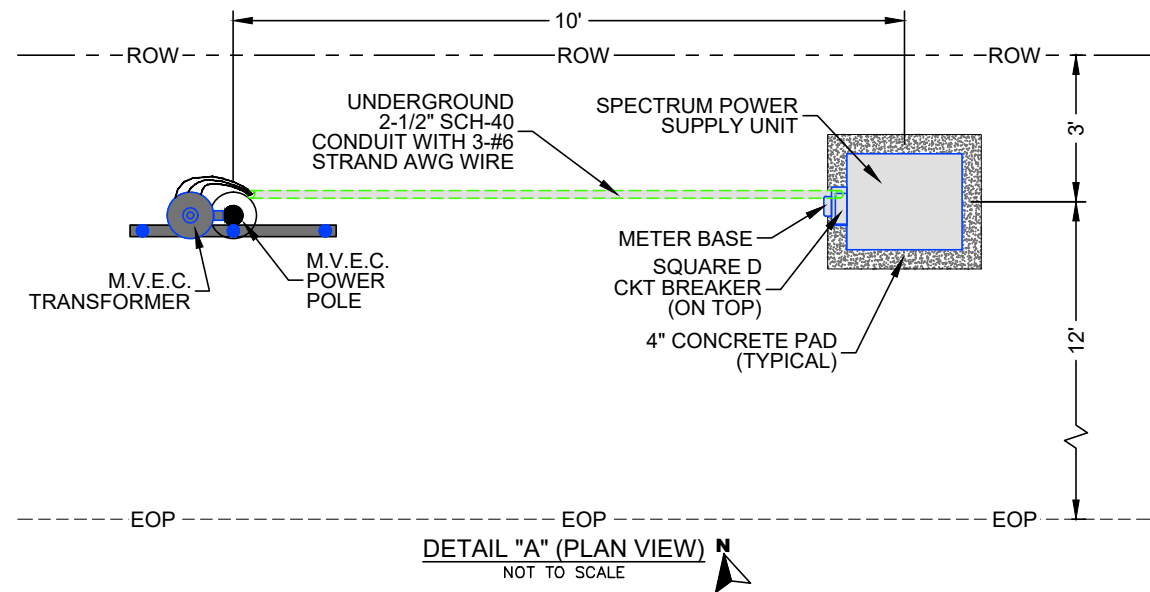

PROJECT NAME: SPECTRUM POWER SUPPLY AT CARDINAL HILLS SUBDIVISION		
ADDRESS: ALONG NORTH SIDE OF VISTA BONITA ROAD APPROX. 1435' WEST FROM BRUSHLINE ROAD		
PRISM #: 1907350	DATE: 2/17/2024	SCALE: NTS
PAGE: 2 OF 3	CITY: EDINBURG	

LEGEND			
	EXIST. POWER POLE		EXIST. PEDESTAL
	PROP. POWER POLE		PROP. PEDESTAL
	RIGHT OF WAY LINE		EXIST. UNDERGROUND
	EDGE OF PAVEMENT		PROP. UNDERGROUND
	EDGE OF SIDEWALK		PROP. OVERLASH
	RISER		PROP. NEW BUILD

ThermalPro® Access Outdoor Equipment Cabinets



POWER SUPPLY UNIT / CABINET PICTURE-1
NOT TO SCALE



POWER SUPPLY UNIT / CABINET PICTURE-2
NOT TO SCALE

Features & Benefits

- Full featured general purpose cabinets
- Wide variety of sizes available
- Telecordia GR-487 compliant
- Broad selection of options to tailor-fit to any application
- Available fully integrated as turn-key solution

Features

- Single bay outdoor equipment cabinet, up to 23RU
- Optional 14.5" H battery pedestal
- Optional 6" H pad mount plinth
- Front and rear rails available
- Fixed racks, adjustable, 19" or 23"
- Swing-out racks, 19" or 23"
- Front door with wind-stop and padlock hasps
- Rear access panel or door
- Universal pole / wall mount brackets
- Double wall roof for protection against solar load
- Environmental gasket seals for all access points
- Multiple cable entry locations
- Heavy-duty aluminum construction
- Durable powder coat paint finish



Overview

The ThermalPro® Access Series is a comprehensive line of general purpose cabinets with flexibility to fit in any industry. With a broad range of sizes and available options, the ThermalPro Access Series cabinets are well suited for a variety of applications. Whether it is cell site backhaul, fiber network distribution, transit or utilities, we have the expertise to configure these cabinets to fit your needs.

Optional Equipment

- Air conditioners, heat exchangers and fan systems
- AC power equipment: load centers, outlets, surge suppression
- DC power equipment: rectifier systems
- Battery back up strings and UPS systems
- Generator connectors and power meter bases
- Cabinet and battery heaters
- Fiber routing raceways and management
- Fiber optic pigtails, splitters and distribution panels
- Protection or cross-connect panels

This product may be protected by one or more patents • For further information, please visit: www.ppc-online.com/patents

customerservice@ppc-online.com • 1-800-800-6652 • www.ppc-online.com

ThermalPro® Access Outdoor Equipment Cabinets



Technical Data

Dimensions

10U-18 (H x W x D)	13U-18 (H x W x D)	13U-24 (H x W x D)	17U-18 (H x W x D)	17U-24 (H x W x D)	20U-24 (H x W x D)	23U-24 (H x W x D)	23U-36 (H x W x D)
mm (in)	mm (in)	mm (in)	mm (in)	mm (in)	mm (in)	mm (in)	mm (in)
660 x 813 x 457 (26 x 32 x 18)	813 x 813 x 457 (32 x 32 x 18)	813 x 813 x 610 (32 x 32 x 24)	965 x 813 x 457 (38 x 32 x 18)	965 x 813 x 610 (38 x 32 x 24)	1118 x 813 x 610 (44 x 32 x 24)	1270 x 813 x 610 (50 x 32 x 24)	1270 x 813 x 914 (50 x 32 x 36)

Mechanical Drawing

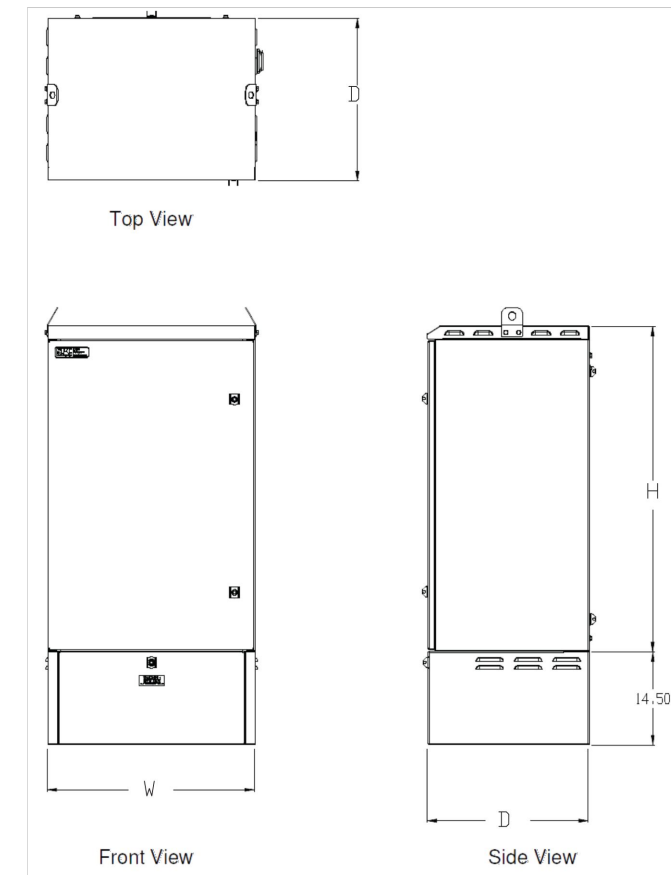

rev1_07282020

Shown with optional battery pedestal

This product may be protected by one or more patents • For further information, please visit: www.ppc-online.com/patents

customerservice@ppc-online.com • 1-800-800-6652 • www.ppc-online.com

POWER SUPPLY UNIT / CABINET TYPICAL DETAIL & SPECIFICATIONS

NOT TO SCALE

PROJECT NAME: SPECTRUM POWER SUPPLY AT CARDINAL HILLS SUBDIVISION		
ADDRESS: ALONG NORTH SIDE OF VISTA BONITA ROAD APPROX. 1435' WEST FROM BRUSHLINE ROAD		
PRISM #: 1907350	DATE: 2 / 17 / 2024	SCALE: NTS
PAGE: 3 OF 3	CITY: EDINBURG	

LEGEND

⊙	EXIST. POWER POLE	■	EXIST. PEDESTAL
⊕	PROP. POWER POLE	□	PROP. PEDESTAL
—ROW—	RIGHT OF WAY LINE	▬▬▬▬▬▬	EXIST. UNDERGROUND
—EOP—	EDGE OF PAVEMENT	▬▬▬▬▬▬	PROP. UNDERGROUND
—SW—	EDGE OF SIDEWALK	▬▬▬▬▬▬	PROP. OVERLASH
Ⓡ	RISER	▬▬▬▬▬▬	PROP. NEW BUILD



PART # SELECTED

PRISM ID:	1907350 - Map	Originator:	Antonio Guzman	Business/Company Name:	BRN FTTH Cardinal Hills Subdivision
Construction Type:	Brownfield-Community	Const Supervisor:	Castro, Osiel T	Address:	24010 TOUCAN DR
Process State:	S3 - Survey in Review	Construction Coordinator:	Villanueva, Fred - p2159426	City/State/Zip:	EDINBURG, TX 78542
Project Status:	In Progress	Total Project Cost:	173799.63	Cross Street:	
Input Date:	01/07/20	Total Passings:	44	Prop Dev Status:	
Hub:	EM - EDINBURG-TX	Tentative Svc Dt:		Coax:	N/A
Node:	EM151 - EM151	Entity:	1904	Fiber:	N/A
Construction Due Date:		Priority Class:		Construction Survey Completed:	Yes

Project Design			
Entity:	1904-South Texas-TX	Management Area:	TR3-South Texas
Map Grid:	Lat: 26 Deg 22' 15" N, Long: 98 Deg 4' 12" W	Services from Survey:	
Project Approved Date:		Orig Tentative Svc Date:	Est Fiber Splice Date:
Construction Sub Type:		Node Capacity:	Special Initiative:

Design Log New Design Design Number: 2579137

NODE: EM19E
INSTANCE: TEXMEX
MAP: 26.3764204778312,
-98.071060031006
AFTER PRINT

TIE POINT LOCATION

