



Anthony Uresti
Director of Planning

HIDALGO COUNTY PLANNING DEPARTMENT

2818 S. BUSINESS HWY 281
EDINBURG TEXAS 78539
Tel. 956-318-2840

HIDALGO COUNTY COMMISSIONERS COURT MEETING

DATE: 11-26-2024

PROPOSED EMERALD ACRES SUBDIVISION, PRECINCT No. 1.

ENGINEER MELDEN AND HUNT INC. DEVELOPER: EVERGREEN LAND & PROPERTIES, LLC.

PRELIMINARY APPROVAL FINAL APPROVAL FINAL APPROVAL WITH FINANCIAL GUARANTEE WITH VARIANCE

NUMBER OF LOTS: 48 *SINGLE FAMILY *MULTI-FAMILY COMMERCIAL INSTITUTIONAL

NUMBER OF STREETLIGHTS: 11

FILLING STATIONS: 4

LOCATION DESCRIPTION: SOUTH SIDE OF ELDORA ROAD, APPROXIMATELY ¼ OF MILE EAST OF VALVERDE ROAD.

SUBDIVISION LIES WITHIN THE: ETJ OF CITY OF DONNA

DRAINAGE REPORT WAS APPROVED BY HCDD#1: ON 8-22-2023 PROPERTY LIES WITHIN FLOOD ZONE: "C" AS PER FEMA.

DRAINAGE DESIGN: DRAINAGE WILL BE PROVIDED BY STORM SEWER SYSTEM AND DETENTION WILL BE PROVIDED BY WIDENING OF EXISTING DRAIN DITCH.

ROAD R.O.W. DEDICATION: 20.0 FEET ONTO ELDORA ROAD.

H.C.R.O.W. FINAL APPROVAL DATE: 8-06-2024 BY, PRECINCT 1 R.O.W. AGENT

H.C.H.D. FINAL APPROVAL DATE: 9-17-2024 BY, ENVIRONMENTAL HEALTH DIVISION MANAGER

SEWER SYSTEM: OSSF'S HAVE BEEN ESCROWED.

WATER SERVICE PROVIDER: N.A.W.S.C. LINE SIZE: 12" LOCATION: VALVERDE ROAD.

H.C.E.O.C. FINAL APPROVAL DATE: 7-31-2024: BY ENVIRONMENTAL COMPLIANCE COORDINATOR

LARGE CONSTRUCTION

The applicant has submitted the required NOI as per Part II, Section E of the TPDES General Permit for Construction Activities (TXR150000) along with a copy of the Erosion Control Plan for the proposed Project.

REQUEST FOR FINAL APPROVAL WITH: **CASH DEPOSIT: Amount: \$72,000.00 For: (48 OSSF'S)**

PRELIMINARY APPROVAL FROM THE
HIDALGO COUNTY COMMISSIONERS COURT ON: SEPTEMBER 26, 2023

STAFF RECOMMENDS: **Preliminary Approval** *subject to comments and future recommendations by planning, Other departments, and the approval of the City of DONNA.*

Final Approval *subject to recommendations other departments*

This subdivision plat has been reviewed and complies with the Hidalgo County Subdivision Rules, Texas Water Development Board Model Subdivision Rules and The Texas Local Government Code.

*



HIDALGO COUNTY PLANNING DEPARTMENT

Anthony Uresti
Director of Planning

2818 S. BUSINESS HWY 281
EDINBURG TEXAS 78539
Tel. 956-318-2840

SUBDIVISION ADVISORY BOARD REGULAR MEETING

DATE: 11-19-2024

PROPOSED EMERALD ACRES SUBDIVISION, PRECINCT No. 1.

ENGINEER MELDEN AND HUNT INC. DEVELOPER: EVERGREEN LAND & PROPERTIES, LLC,

PRELIMINARY APPROVAL FINAL APPROVAL FINAL APPROVAL WITH FINANCIAL GUARANTEE WITH VARIANCE

NUMBER OF LOTS: 48 *SINGLE FAMILY *MULTI-FAMILY COMMERCIAL INSTITUTIONAL

NUMBER OF STREETLIGHTS: 11

FILLING STATIONS: 4

LOCATION DESCRIPTION: SOUTH SIDE OF ELDORA ROAD, APPROXIMATELY ¼ OF MILE EAST OF VALVERDE ROAD.

SUBDIVISION LIES WITHIN THE: ETJ OF CITY OF DONNA

DRAINAGE REPORT WAS APPROVED BY HCDD#1: ON 8-22-2023 PROPERTY LIES WITHIN FLOOD ZONE: "C" AS PER FEMA.

DRAINAGE DESIGN: DRAINAGE WILL BE PROVIDED BY STORM SEWER SYSTEM AND DETENTION WILL BE PROVIDED BY WIDENING OF EXISTING DRAIN DITCH.

ROAD R.O.W. DEDICATION: 20.0 FEET ONTO ELDORA ROAD.

H.C.R.O.W. FINAL APPROVAL DATE: 8-06-2024 BY, PRECINCT 1 R.O.W. AGENT

H.C.H.D. FINAL APPROVAL DATE: 9-17-2024 BY, ENVIRONMENTAL HEALTH DIVISION MANAGER

SEWER SYSTEM: OSSF'S HAVE BEEN ESCROWED.

WATER SERVICE PROVIDER: N.A.W.S.C. LINE SIZE: 12" LOCATION: VALVERDE ROAD.

H.C.E.O.C. FINAL APPROVAL DATE: 7-31-2024: BY ENVIRONMENTAL COMPLIANCE COORDINATOR

LARGE CONSTRUCTION

The applicant has submitted the required NOI as per Part II, Section E of the TPDES General Permit for Construction Activities (TXR150000) along with a copy of the Erosion Control Plan for the proposed Project.

REQUEST FOR FINAL APPROVAL WITH: **CASH DEPOSIT: Amount: \$72,000.00 For: (48 OSSF'S)**

PRELIMINARY APPROVAL FROM THE
HIDALGO COUNTY COMMISSIONERS COURT ON: SEPTEMBER 26, 2023

STAFF RECOMMENDS: **Preliminary Approval** *subject to comments and future recommendations by planning, Other departments, and the approval of the City of DONNA.*

Final Approval *subject to recommendations other departments*

This subdivision plat has been reviewed and complies with the Hidalgo County Subdivision Rules, Texas Water Development Board Model Subdivision Rules and The Texas Local Government Code.

*

STATE OF TEXAS
COUNTY OF HIDALGO

OWNER'S DEDICATION, CERTIFICATION, AND ATTESTATION

WE, EVERGREEN LAND & PROPERTIES, LLC, AS OWNER OF THE 30.00 ACRES TRACT OF LAND ENCOMPASSED WITHIN THE PROPOSED EMERALD ACRES SUBDIVISION, HEREBY SUBDIVIDE THE LAND AS DEPICTED IN THIS SUBDIVISION PLAT AND DEDICATE TO PUBLIC USE THE STREETS, PARK, AND EASEMENTS SHOWN HEREIN. I CERTIFY THAT I HAVE COMPLIED WITH THE REQUIREMENTS OF TEXAS LOCAL GOVERNMENT CODE § 232.032 AND THAT:

(A) THE WATER QUALITY AND CONNECTIONS TO THE LOTS MEET, OR WILL MEET THE MINIMUM STATE STANDARDS;
(B) SEWER CONNECTIONS TO THE LOTS OR SEPTIC TANKS MEET, OR WILL MEET THE MINIMUM REQUIREMENTS OF STATE STANDARDS;
(C) ELECTRICAL CONNECTIONS PROVIDED TO THE LOTS MEET, OR WILL MEET THE MINIMUM STATE STANDARDS; AND
(D) GAS CONNECTIONS, IF AVAILABLE, PROVIDED TO THE LOTS MEET, OR WILL MEET THE MINIMUM STATE STANDARDS.

I ATTEST THAT THE MATTERS ASSERTED IN THIS PLAT ARE TRUE AND COMPLETE.
EVERGREEN LAND & PROPERTIES, LLC, A TEXAS LIMITED LIABILITY COMPANY

SHAVI MAHTANI DATE: _____
100 E. NOLANA AVENUE SUITE 130
MCALLEN, TEXAS 78504

STATE OF TEXAS
COUNTY OF HIDALGO:

BEFORE ME, THE UNDERSIGNED AUTHORITY ON THIS DAY PERSONALLY APPEARED SHAVI MAHTANI, KNOWN TO ME TO BE THE PERSON WHOSE NAME IS SUBSCRIBED TO THE FOREGOING INSTRUMENT, AND ACKNOWLEDGED TO ME THAT HE EXECUTED THE SAME FOR THE PURPOSES AND CONSIDERATIONS THEREIN GIVEN UNDER MY HAND AND SEAL OF OFFICE.

THIS _____ DAY OF _____, 20____.

NOTARY PUBLIC IN THE STATE OF TEXAS
MY COMMISSION EXPIRES: _____

STATE OF TEXAS
COUNTY OF HIDALGO

I, THE UNDERSIGNED, MARIO A. REYNA, A LICENSED PROFESSIONAL ENGINEER IN THE STATE OF TEXAS, DO HEREBY CERTIFY THAT PROPER ENGINEERING CONSIDERATION HAS BEEN GIVEN TO THIS PLAT AND IS A TRUE AND ACCURATE REPRESENTATION OF THE SUBDIVISION OF THE LANDS HEREON DESCRIBED.

MARIO A. REYNA, P.E. # 117368 DATE: _____
DATE PREPARED: 04/26/19 BY: CIRO
ENG. JOB NO. 23111.00

MELDEN & HUNT, INC.
TEXAS REGISTRATION F-1435



STATE OF TEXAS
COUNTY OF HIDALGO:

I, THE UNDERSIGNED, ROBERTO N. TAMEZ, A REGISTERED PROFESSIONAL LAND SURVEYOR, IN THE STATE OF TEXAS, DO HEREBY CERTIFY THAT THE HEREIN PREPARED PLAT AND DESCRIPTION OF EMERALD ACRES SUBDIVISION, WERE PREPARED FROM A SURVEY OF THE PROPERTY MADE ON THE GROUND BY ME OR UNDER MY SUPERVISION ON 04-26-23, AND THAT IT IS A TRUE AND ACCURATE REPRESENTATION OF THE SUBDIVISION OF THE LANDS HEREON DESCRIBED.

ROBERTO N. TAMEZ, R.P.L.S. # 6238
DATE SURVEYED: 04-24-2023
T-1160, PAGE 81-82
SURVEY JOB NO. 23456.08



THIS PLAT IS HEREBY APPROVED BY THE DONNA IRRIGATION DISTRICT ON

THIS THE _____ DAY OF _____, 20____.

NO IMPROVEMENTS OF ANY KIND (INCLUDING WITHOUT LIMITATION TREES, FENCES AND BUILDINGS) SHALL BE PLACED UPON DONNA IRRIGATION DISTRICT RIGHT OF WAYS OR EASEMENTS. APPROVAL OF THIS PLAT DOES NOT RELEASE ANY RIGHTS THAT THE DISTRICT MAY HAVE WHETHER SHOWN OR NOT.

PRESIDENT ATTEST: SECRETARY

HIDALGO COUNTY
CERTIFICATE OF PLAT APPROVAL
UNDER LOCAL GOVERNMENT CODE § 232.028 (A)

WE, THE UNDERSIGNED CERTIFY THAT THIS PLAT OF EMERALD ACRES SUBDIVISION WAS REVIEWED AND APPROVED BY THE HIDALGO COUNTY COMMISSIONERS COURT ON _____ DAY OF _____, 20____.

HIDALGO COUNTY JUDGE DATE: _____

ATTEST: HIDALGO COUNTY CLERK DATE: _____

PLAT OF EMERALD ACRES SUBDIVISION

BEING A RE-SUBDIVISION OF 30.00 ACRES
BEING PART OR PORTION OF BLOCK 167 & 168
HILL HALBERT SUBDIVISION
VOLUME 1, PAGES 35, H.C.M.R.

RIGHT OF WAY EASEMENT

KNOW ALL MEN BY THESE PRESENTS, THAT THE UNDERSIGNED, OWNERS OF THE PROPERTY SHOWN ON THIS PLAT, THEIR SUCCESSORS, ASSIGNS, AND TRANSFEREES (HEREINAFTER CALLED "GRANTOR" WHETHER ONE OR MORE PERSONS ARE NAMED), IN CONSIDERATION OF ONE DOLLAR (\$1.00) AND OTHER GOOD AND VALUABLE CONSIDERATION PAID BY NORTH ALAMO WATER SUPPLY CORPORATION, (HEREINAFTER CALLED "GRANTEE"), THE RECEIPT AND SUFFICIENCY OF WHICH IS HEREBY ACKNOWLEDGED, DOES HEREBY GRANT, BARGAIN, SELL, TRANSFER AND CONVEY TO SAID GRANTEE, ITS SUCCESSORS AND ASSIGNS, AN EXCLUSIVE PERPETUAL EASEMENT WITH THE RIGHT TO ERECT, CONSTRUCT, INSTALL AND LAY AND THEREAFTER USE, OPERATE, INSPECT, REPAIR, MAINTAIN, REPLACE AND REMOVE WATER DISTRIBUTION LINES AND APPURTENANCES OVER AND ACROSS THE LANDS SHOWN ON THIS PLAT, TOGETHER WITH THE RIGHT OF INGRESS AND EGRESS OVER GRANTOR'S ADJACENT LANDS FOR THE PURPOSE FOR WHICH THE ABOVE-MENTIONED RIGHTS ARE GRANTED. THE EASEMENT HEREBY GRANTED SHALL NOT EXCEED 15' IN WIDTH, AND GRANTEE IS HEREBY AUTHORIZED TO DESIGNATE THE COURSE OF THE EASEMENT HEREIN CONVEYED EXCEPT THAT WHEN THE PIPELINE(S) IS INSTALLED, THE EASEMENT HEREIN GRANTED SHALL BE LIMITED TO A STRIP OF LAND 15' IN WIDTH, THE CENTER LINE THEREOF BEING THE PIPELINE INSTALLED.

IN THE EVENT THE EASEMENT HEREBY GRANTED ABUTS ON A PUBLIC ROAD AND THE CITY, COUNTY OR STATE HEREAFTER WIDENS OR RELOCATES THE PUBLIC ROAD SO AS TO REQUIRE THE RELOCATION OF THIS WATER LINE AS INSTALLED, GRANTEE FURTHER GRANTS TO GRANTEE AN ADDITIONAL EASEMENT OVER AND ACROSS THE LAND SHOWN ON THIS PLAT FOR THE PURPOSE OF LATERALLY RELOCATING SAID WATER LINE AS MAY BE NECESSARY TO CLEAR THE ROAD IMPROVEMENTS, WHICH EASEMENT HEREBY GRANTED SHALL BE LIMITED TO A STRIP OF LAND 15' IN WIDTH, THE CENTER LINE THEREOF BEING THE PIPELINE AS RELOCATED.

THE CONSIDERATION RECITED HEREIN SHALL CONSTITUTE PAYMENT IN FULL FOR ALL DAMAGES SUSTAINED BY GRANTEE BY REASON OF THE INSTALLATION, MAINTENANCE, REPAIR, REPLACEMENT AND RELOCATION OF THE STRUCTURES REFERRED TO HEREIN. THIS AGREEMENT TOGETHER WITH OTHER PROVISIONS OF THIS GRANT SHALL CONSTITUTE AN EASEMENT FOR THE BENEFIT OF THE GRANTEE, ITS SUCCESSORS, AND ASSIGNS. THE GRANTEE COVENANTS THAT IT IS THE OWNER OF THE ABOVE-DESCRIBED LANDS AND THAT SAID LANDS ARE FREE AND CLEAR OF ALL ENCUMBRANCES AND LIENS, EXCEPT THE FOLLOWING:

THE EASEMENT CONVEYED HEREIN WAS OBTAINED OR IMPROVED THROUGH FEDERAL FINANCIAL ASSISTANCE. THIS EASEMENT IS SUBJECT TO THE PROVISIONS OF THE TITLE VI OF THE CIVIL RIGHTS ACT OF 1964 AND THE REGULATIONS ISSUED PURSUANT THERETO FOR SO LONG AS THE EASEMENT CONTINUES TO BE USED FOR THE SAME OR SIMILAR PURPOSE FOR WHICH FINANCIAL ASSISTANCE WAS EXTENDED OR FOR SO LONG AS THE GRANTEE OWNS IT, WHICHEVER IS LONGER.

IN WITNESS WHEREOF, THE SAID GRANTEE HAS EXECUTED THIS INSTRUMENT THE DAY OF _____ DAY OF _____, 20____.

EVERGREEN LAND & PROPERTIES, LLC, A TEXAS LIMITED PARTNERSHIP

SHAVI MAHTANI DATE: _____
100 E. NOLANA AVENUE SUITE 130
MCALLEN, TEXAS 78504

ACKNOWLEDGMENT

THE STATE OF TEXAS §
COUNTY OF HIDALGO §

BEFORE ME, THE UNDERSIGNED, A NOTARY PUBLIC IN AND FOR SAID COUNTY AND STATE, ON THIS DAY PERSONALLY APPEARED SHAVI MAHTANI, KNOWN TO ME TO BE THE PERSON WHOSE NAME IS SUBSCRIBED TO THE FOREGOING INSTRUMENT, AND ACKNOWLEDGED TO ME THAT HE EXECUTED THE SAME FOR THE PURPOSES AND CONSIDERATION THEREIN EXPRESSED.

GIVEN UNDER MY HAND AND SEAL OF OFFICE THIS THE _____ DAY OF _____, 20____.

NOTARY PUBLIC, STATE OF TEXAS
MY COMMISSION EXPIRES: _____

CITY OF DONNA
CERTIFICATE OF PLAT APPROVAL
UNDER LOCAL GOVERNMENT CODE § 212.009(C) AND § 212.0115(B)

WE, THE UNDERSIGNED, CERTIFY THAT THIS PLAT OF EMERALD ACRES SUBDIVISION, WAS REVIEWED AND APPROVED BY THE PLANNING AND ZONING COMMISSION OF THE CITY OF DONNA

ON _____ DAY OF _____, 20____.

P&Z CHAIRMAN OF THE CITY OF DONNA DATE: _____

CITY OF DONNA
CERTIFICATE OF PLAT APPROVAL
UNDER LOCAL GOVERNMENT CODE § 212.009(C) AND § 212.0115(B)

WE, THE UNDERSIGNED, CERTIFY THAT THIS PLAT OF EMERALD ACRES SUBDIVISION, WAS REVIEWED AND APPROVED BY THE CITY COUNCIL OF THE CITY OF DONNA

ON _____ DAY OF _____, 20____.

MAYOR OF THE CITY OF DONNA DATE: _____

ATTEST:

SECRETARY OF THE CITY OF DONNA DATE: _____

LOCATION OF SUBDIVISION WITH RESPECT TO THE EXTRATERRITORIAL JURISDICTION OF A MUNICIPALITY:

EMERALD ACRES SUBDIVISION IS LOCATED IN THE SOUTHEAST PART OF HIDALGO COUNTY ON THE SOUTH SIDE OF MILE 11 NORTH ROAD (ELDORA ROAD) AND APPROXIMATELY 840 FEET EAST VAL VERDE ROAD, THE ONLY NEARBY MUNICIPALITY IS THE CITY OF DONNA. ACCORDING TO THE OFFICIAL MAP IN THE OFFICE OF THE SECRETARY OF THE CITY OF DONNA (POPULATION 17,429), EMERALD ACRES SUBDIVISION LIES APPROXIMATELY 0.1 OF ONE MILE FROM THE CITY LIMITS (AND IS WITHIN THE 2 MILE EXTRATERRITORIAL JURISDICTION (ETJ) UNDER LOCAL GOVERNMENT CODE § 42.021. THIS SUBDIVISION FALLS WITHIN PRECINCT 1.

48 LOTS SCALE 1" = 1000'

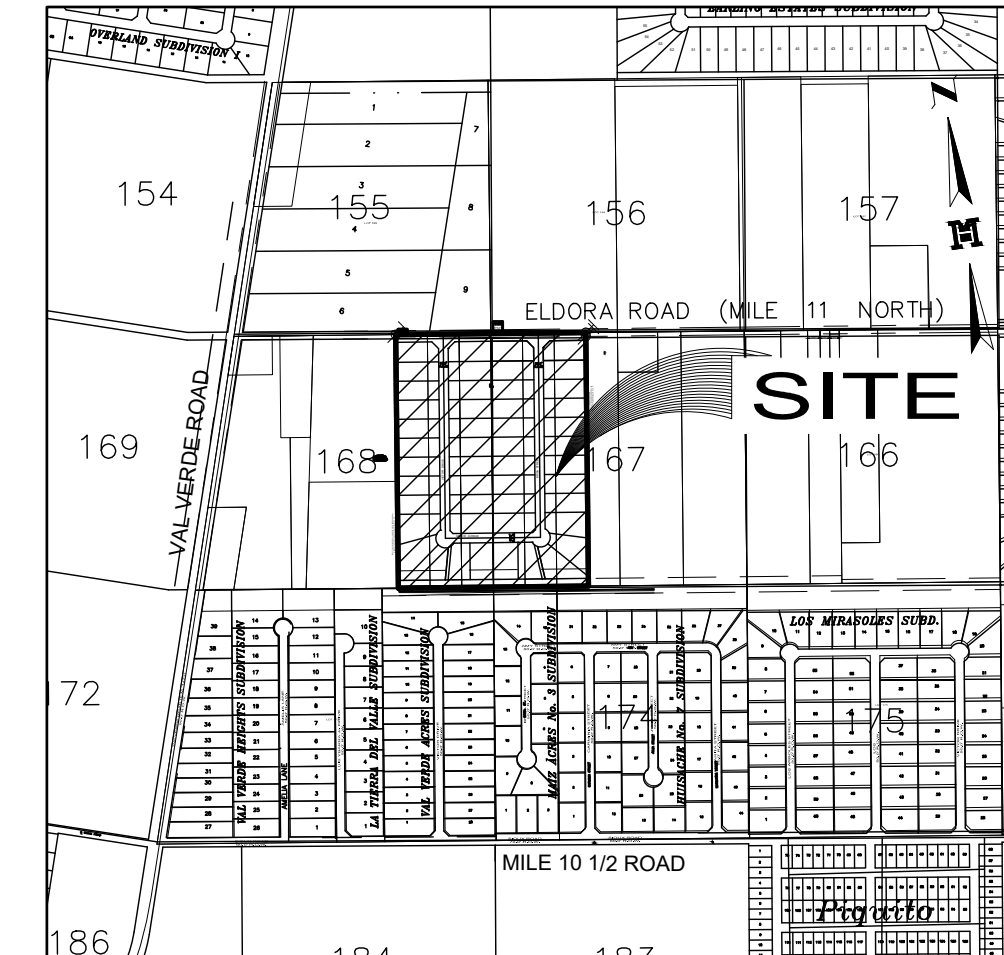

INDEX TO SHEET OF EMERALD ACRES SUBDIVISION

SHEET 1: HEADING; INDEX; LOCATION MAP & ETJ; PRINCIPAL CONTACTS; MAP; LOT, STREETS, AND EASEMENT LAYOUT; OWNER'S DEDICATION, CERTIFICATION; SURVEYOR'S CERTIFICATION; ENGINEERING CERTIFICATION; ATTESTATION; CITY; CITY MAYOR CERTIFICATION; CITY PLANNING & ZONING CERTIFICATE; IRRIGATION DISTRICT, H.C.D.D. NO. 1; N.A.W.S.C. CERTIFICATION; COUNTY CLERK'S RECORDING CERTIFICATE; HIDALGO COUNTY JUDGE CERTIFICATE; LOT CURVE TABLE, LOT LINE TABLE.

SHEET 2: HEADING; DESCRIPTION (METES AND BOUNDS); PLAT NOTES AND RESTRICTIONS; LOT AREA TABLE.

SHEET 3: WATER LAYOUT AND DISTRIBUTION; ENGINEERING REPORT, INCLUDING DESCRIPTION OF WATER AND ENGINEERS CERTIFICATION (ENGLISH AND SPANISH VERSION) WATER DETAILS.

SHEET 4: SEPTIC TANK LAYOUT IMPROVEMENTS; ENGINEERING REPORT, INCLUDING DESCRIPTION OF SANITARY SEWER AND ENGINEERS CERTIFICATION (ENGLISH AND SPANISH VERSION), SUBDIVIDER CERTIFICATION.

SHEET 5: MAP OF TOPOGRAPHY AND DRAINAGE, REPORT INCLUDING DESCRIPTION OF DRAINAGE AND DITCH WIDENING, ENGINEERING CERTIFICATION; STORM CONSTRUCTION DETAILS.

SHEET 6: MAP OF TOPOGRAPHY AND PAVING; CONSTRUCTION DETAILS.

ON: _____ AT _____ AM/PM

INSTRUMENT NUMBER _____
OF THE MAP RECORDS OF HIDALGO COUNTY, TEXAS

BY: _____ DEPUTY



FILED FOR RECORD IN
HIDALGO COUNTY
ARTURO GUAJARDO, JR.
HIDALGO COUNTY CLERK

SHEET 1 OF 6 SHEETS

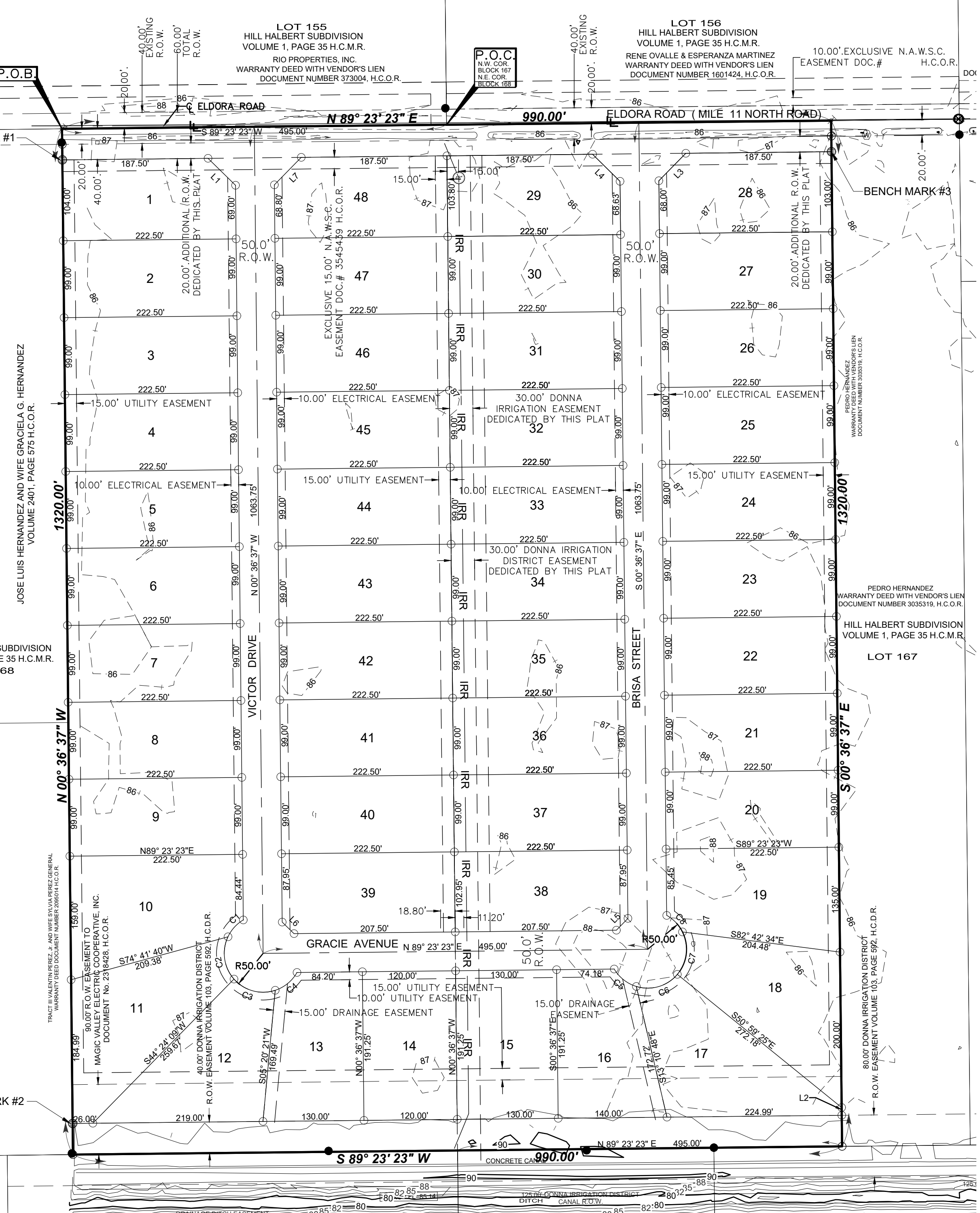

LEGEND

- FOUND NO. 4 REBAR
 - ▲ FOUND COTTON PICKER SPINDLE
 - SET NO. 4 REBAR WITH PLASTIC CAP STAMPED MELDEN & HUNT, INC.
 - ▽ SET NAIL
 - ⊙ FOUND NAIL
 - ⊙ MH MONUMENT SET IN CONCRETE
 - IRRIGATION STAND PIPE (SIZE AS NOTED)
- R.O.W. - RIGHT OF WAY
H.C.M.R. - HIDALGO COUNTY MAP RECORDS
H.C.D.R. - HIDALGO COUNTY DEED RECORDS
H.C.O.R. - HIDALGO COUNTY OFFICIAL RECORDS
P.O.B. - POINT OF BEGINNING
P.O.C. - POINT OF COMMENCING
N.E. COR. - NORTHEAST CORNER
N.W. COR. - NORTHWEST CORNER
Ac. - OF ONE ACRE

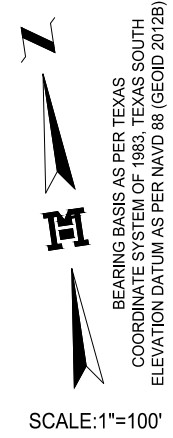

Curve Table						
Curve #	Length	Radius	Delta	Chord Direction	Chord Length	Tangent
C1	29.74'	50.00'	034° 04' 39"	S42° 21' 03"W	29.30'	15.32'
C2	58.24'	50.00'	066° 44' 04"	S8° 03' 18"E	55.00'	32.93'
C3	58.24'	50.00'	066° 44' 02"	S74° 47' 22"E	55.00'	32.93'
C4	37.05'	50.00'	042° 27' 30"	N50° 36' 52"E	36.21'	19.42'
C5	37.05'	50.00'	042° 27' 27"	S51° 50' 09"E	36.21'	19.42'
C6	58.24'	50.00'	066° 44' 02"	N73° 34' 07"E	55.00'	32.93'
C7	58.24'	50.00'	066° 44' 03"	N8° 50' 04"E	55.00'	32.93'
C8	29.74'	50.00'	034° 04' 41"	N43° 34' 17"W	29.30'	15.32'

Line Table		
Line #	Direction	Length
L1	N 45° 36' 37" W	49.50'
L2	S 00° 36' 37" E	10.00'
L3	N 44° 23' 23" E	49.50'
L4	S 45° 28' 15" E	49.62'
L5	S 44° 23' 23" W	21.21'
L6	N 45° 36' 37" W	21.21'
L7	N 44° 23' 23" E	49.50'

HIDALGO COUNTY CERTIFICATE OF PLAT APPROVAL HIDALGO COUNTY DRAINAGE DISTRICT NO. 1

HIDALGO COUNTY DRAINAGE DISTRICT NO. 1 HEREBY CERTIFIES THAT THE DRAINAGE PLANS FOR THIS SUBDIVISION COMPLY WITH THE MINIMUM STANDARDS OF THE DISTRICT ADOPTED UNDER TEXAS WATER CODE 49.211 (c). THE DISTRICT HAS NOT REVIEWED AND DOES NOT CERTIFY THAT THE DRAINAGE STRUCTURES DESCRIBED ARE APPROPRIATE FOR THE SPECIFIC SUBDIVISION, BASED ON GENERALLY ACCEPTED ENGINEERING CRITERIA. IT IS THE RESPONSIBILITY OF THE DEVELOPER AND HIS ENGINEER TO MAKE THEIR DETERMINATIONS.

HIDALGO COUNTY DRAINAGE DISTRICT NO. 1

RAUL E. SESIN P.E., C.F.M. DATE: _____
GENERAL MANAGER

MELDEN & HUNT, INC.
TEXAS REGIST. F-1435

MELDEN & HUNT INC.
CONSULTANTS • ENGINEERS • SURVEYORS

115 W. McINTYRE - EDINBURG, TX 78541
PH: (956) 381-0981 • FAX: (956) 381-1839
ESTABLISHED 1947 - www.meldenandhunt.com

PRINCIPAL CONTACTS				
NAME	ADDRESS	CITY & ZIP	PHONE	FAX
OWNER:	EVERGREEN LAND & PROPERTIES, LLC	100 E. NOLANA AVENUE SUITE 130	MCALLEN, TEXAS 78504	C/O(956) 381-0981 C/O(956) 381-1839
ENGINEER:	MARIO A. REYNA P.E.	115 W. McINTYRE	EDINBURG, TX 78541	(956) 381-0981 (956) 381-1839
SURVEYOR:	ROBERTO N. TAMEZ R.P.L.S.	115 W. McINTYRE	EDINBURG, TX 78541	(956) 381-0981 (956) 381-1839

DRAWN BY: CIRO DATE: 05/02/24
SURVEYED, CHECKED DATE: _____
FINAL CHECK DATE: _____

PLAT OF EMERALD ACRES SUBDIVISION

BEING A RE-SUBDIVISION OF 30.000 ACRES
BEING PART OR PORTION OF BLOCK 167 & 168
HILL HALBERT SUBDIVISION
VOLUME 1, PAGES 35, H.C.M.R.

Lot Area Table		
Lot #	SQ. FT.	Area
1	22528.08	0.517
2	22027.87	0.506
3	22027.21	0.506
4	22027.24	0.506
5	22027.27	0.506
6	22027.30	0.506
7	22027.33	0.506
8	22027.36	0.506
9	22027.39	0.506
10	28680.78	0.658
11	27183.52	0.624
12	24385.66	0.560
13	22581.46	0.518
14	22950.77	0.527
15	24863.59	0.571
16	22352.55	0.513
17	26133.57	0.600
18	26281.45	0.603
19	26372.93	0.605
20	22027.86	0.506

Lot Area Table		
Lot #	SQ. FT.	Area
21	22027.86	0.506
22	22027.86	0.506
23	22027.86	0.506
24	22027.86	0.506
25	22027.86	0.506
26	22027.86	0.506
27	22027.86	0.506
28	22305.57	0.512
29	22480.15	0.516
30	22026.82	0.506
31	22027.36	0.506
32	22028.28	0.506
33	22026.79	0.506
34	22027.42	0.506
35	22027.44	0.506
36	22028.17	0.506
37	22027.06	0.506
38	22793.55	0.523
39	22793.56	0.523
40	22027.09	0.506

Lot Area Table		
Lot #	SQ. FT.	Area
41	22028.21	0.506
42	22027.50	0.506
43	22027.50	0.506
44	22028.89	0.506
45	22028.40	0.506
46	22027.50	0.506
47	22026.97	0.506
48	22483.24	0.516

GENERAL PLAT NOTES & RESTRICTIONS:

- FLOOD ZONE STATEMENT:
FLOOD ZONE DESIGNATION: ZONE "C" AREAS OF MINIMAL FLOODING. COMMUNITY-PANEL NO. 480334 0425 C
EFFECTIVE DATE: NOVEMBER 16, 1982.

ZONE "C" COMMUNITY-PANEL NO. 480334 0425 C EFFECTIVE DATE: NOVEMBER 16, 1982 OF THE FEDERAL EMERGENCY MANAGEMENT AGENCY MAPS FOR HIDALGO COUNTY, TEXAS AND THE LOCAL FLOOD PLAIN ADMINISTRATOR HAVE IDENTIFIED NO OTHER AREAS AS SHOWN ON THIS PLAT ARE WITHIN THE PROPOSED SUBDIVISION TO BE WITHIN THE 100-YEAR FLOOD PLAIN. CONSTRUCTION OF RESIDENTIAL HOUSING WITHIN ANY AREA OF THE SUBDIVISION THAT IS IN THE 100-YEAR FLOOD PLAIN IS PROHIBITED UNLESS THE HOUSING QUALIFIES FOR INSURANCE UNDER THE NATIONAL FLOOD INSURANCE ACT OF 1968 (42 U.S.C. SECTIONS 4001 THROUGH 4127).
- SETBACKS:
FRONT: 25.00 FEET. CUL-DE-SAC 15.00 FEET
REAR: 15.00 FEET OR EASEMENT WHICHEVER IS GREATER
SIDE: 6.00 FEET OR EASEMENT WHICHEVER IS GREATER
CORNER SIDE: 10.00 FEET CORNER GARAGE SIDE: 18.00 FEET
CORNER GARAGE FRONT: 18.00 FEET
- NO MORE THAN ONE-SINGLE FAMILY DETACHED DWELLING SHALL BE LOCATED ON EACH LOT. THIS MUST BE STIPULATED ON ALL DEEDS AND CONTRACTS FOR DEEDS.
- MINIMUM FINISHED FLOOR ELEVATION SHALL BE 18" ABOVE TOP OF CURB OR 18" ABOVE NATURAL GROUND, WHICHEVER IS GREATER.
- THE FOLLOWING BENCHMARKS ARE IDENTIFIED ON THE FACE OF THE PLAT AND ON THE ATTACHED ENGINEERING PLANS.
-->B.M. NO. 1-ELEV. 86.20 N.G.V.D. 29 OR NAVD 88 DESCRIPTIONS: MHI DISC SET IN CONCRETE AT THE NORTHWEST CORNER OF LOT 1 OF THIS SUBDIVISION. N:1660598.290 E:1122339.550.
-->B.M. NO. 2-ELEV. 86.50 N.G.V.D. 29 OR NAVD 88 DESCRIPTIONS: MHI DISC SET IN CONCRETE AT THE SOUTHWEST CORNER OF LOT 11 OF THIS SUBDIVISION. N:16601598.36 E:1122352.76
-->B.M. NO. 3-ELEV. 86.40 N.G.V.D. 29 OR NAVD 88 DESCRIPTIONS: MHI DISC SET IN CONCRETE AT THE NORTHEAST CORNER OF LOT 28 OF THIS SUBDIVISION. N:16602846.84 E:1123329.49.
- IN ACCORDANCE WITH THE HIDALGO COUNTY DRAINAGE DISTRICT NO. 1 AND HIDALGO COUNTY REQUIREMENTS THIS DEVELOPMENT WILL BE REQUIRED TO DETAIN A TOTAL OF 114,048 CUBIC-FEET 2.618 ACRE-FEET) OF STORM WATER RUNOFF. DRAINAGE RETENTION IN ACCORDANCE WITH THE LOCAL REQUIREMENTS WILL BE ACCOMPLISHED AS FOLLOWS: (SEE SHEET No. 6 FOR STORM SEWER IMPROVEMENTS.)
- THE DEVELOPER SHALL BE RESPONSIBLE TO DETAIN AND ACCOMMODATE MORE THAN THE DETAINED VOLUME SHOWN ABOVE IF ITS DETERMINED AT THE DEVELOPMENT PERMIT STATE ABOVE DUE TO THE IMPERVIOUS AREA BEING GREATER THAT PLAT ENGINEER CONSIDERED FOR HIS CALCULATIONS OF THIS SUBDIVISION.
- ALL LOTS SHALL HAVE A POST DEVELOPMENT FINISH GRADE FROM THE REAR OF THE LOT TO THE CURB AND/OR ROADSIDE DITCH AT A 0.5% SLOPE TO ACCOMPLISH POSITIVE DRAINAGE. THIS IS IN ACCORDANCE WITH HIDALGO COUNTY APPENDIX 5: COUNTY CONSTRUCTION.
- NO STRUCTURE SHALL BE PERMITTED OVER ANY EASEMENT. EASEMENTS SHALL BE KEPT CLEAR OF BUILDINGS, SHEDS, SHRUBS TREES, AND OTHER PLANTINGS (EXCEPT LOW, LESS THAN 18 INCHES MATURE HEIGHT, GROUND COVER, GRASS, OR FLOWERS) AND OTHER OBSTRUCTIONS THAT WOULD INTERFERE WITH THE OPERATIONS AND MAINTENANCE OF THE EASEMENT.
- EACH PURCHASE CONTRACT MADE BETWEEN A SUBDIVIDER AND PURCHASER OF A LOT IN THIS SUBDIVISION SHALL CONTAIN A STATEMENT DESCRIBING HOW AND WHEN WATER, SEWER, ELECTRICITY, AND GAS SERVICES WILL BE MADE AVAILABLE TO THE SUBDIVISION.
- ALL PUBLIC UTILITY EASEMENTS DEDICATED BY THIS PLAT SHALL BE A MINIMUM WIDTH OF 15.00 FEET AS PER THE HIDALGO COUNTY MODEL SUBDIVISION RULES. BY SIGNING THIS PLAT, DEVELOPER AND ENGINEER CERTIFY THAT ALL OTHER EASEMENTS SHOWN COMPLY WITH THE SIZE REQUIRED BY EACH UTILITY PROVIDER OCCUPYING AN EASEMENT.
- CLEARANCES FOR WATER METERS: (ONLY FOR LOTS BEING AS PER LOCAL GOVERNMENT CODE REQUIREMENTS, SANITARY SEWER MUST BE CONNECTED TO A RESIDENCE PRIOR TO THE COUNTY PROCESSING A FINAL CLEARANCE FOR A WATER METER. A SEWER TAP INSPECTION SHALL BE PROVIDED FROM THE ENTITY SERVICE PROVIDER PRIOR TO RECEIVING A CLEARANCE FOR WATER METER.
- ON-SITE SEWAGE FACILITIES (OSSF) NOTE: THIS SUBDIVISION SHALL USE ON-SITE SEWAGE FACILITIES IN ACCORDANCE WITH TCEQ AND HIDALGO COUNTY REGULATIONS FOR SEWAGE DISPOSAL. THE SUBDIVIDER IS RESPONSIBLE FOR PROVIDING AN OSSF ON ALL LOTS.
A. OSSF SYSTEM IS BEING DESIGNED FOR DISPOSAL OF DOMESTIC SEWERAGE ONLY. A SEPARATE DESIGN SHALL BE SUBMITTED FOR COMMERCIAL USE AND MULTI-FAMILY USE.
B. EACH LOT ON THIS PLAT COMPLIES WITH THE MINIMUM 21,780 SQUARE FEET LOT AREA WITH POTABLE WATER SUPPLY.
C. OSSF SYSTEM SHALL REQUIRE INSPECTION AND APPROVAL BY HIDALGO COUNTY AUTHORIZED DEPARTMENT
D. SOIL ANALYSIS HAVE BEEN SUBMITTED TO THE AUTHORIZED HIDALGO COUNTY DEPARTMENT AND EXCERPTS MAY BE ALSO SEEN ON THE UTILITY LAYOUT FOR THIS SUBDIVISION AS SUBMITTED TO THE HIDALGO COUNTY PLANNING DEPARTMENT. THE ENGINEER HAS DETERMINED THAT THE SOIL IS SUITABLE FOR A STANDARD SEPTIC TANK AND ABSORPTIVE DRAIN FIELD SYSTEM.
E. APPROVED "OSSF" PERMIT APPLICATION IS REQUIRED INCLUDING INDIVIDUAL LOT PLANNING MATERIALS PRIOR TO OCCUPYING A LOT.
- 4-FT. SIDEWALK IS REQUIRED ON BOTH SIDES OF ALL INTERIOR STREET AT TIME OF BUILDING PERMIT STAGE.
- FOLLOW LANDSCAPE ORDINANCE AS PER CITY REQUIREMENTS.
- STORM WATER POLLUTION PREVENTION PLAN PRIOR TO BUILDING PERMIT.
- ALL INTERIOR LOT CORNERS ARE SET BY NO. 4 REBAR WITH PLASTIC CAP STAMPED MELDEN & HUNT.
- ALL BEARINGS AND DISTANCES ARE BASED ON GRID COORDINATES.
- LOTS 1, 28, 29 & 48 SHALL NOT HAVE ACCESS ON TO THE MILE 11 NORTH ROAD (ELDORA ROAD).
- ALL IRRIGATION EASEMENT ARE EXCLUSIVE TO DONNA IRRIGATION DISTRICT, AND THE DISTRICT ALLOWS NO OTHER UTILITIES OR OUTSIDE USE WITHOUT ITS EXPRESS WRITTEN APPROVAL.
- NO UTILITY COMPANY, PUBLIC ENTITY, PARTY OR PERSON IS ALLOWED TO CROSS ABOVE OR BELOW GROUND ANY IRRIGATION DISTRICT EASEMENT OR RIGHT-OF-WAY WITH LINES, POLES, OPEN DITCHES OR OTHER USE WITHOUT FIRST OBTAINING A CROSSING PERMIT FROM DONNA IRRIGATION DISTRICT.
- NO PERMANENT STRUCTURE, UTILITY POLE, HOLE, WALL, FENCE, DRIVEWAY, OR ROAD WILL BE ALLOWED TO BE CONSTRUCTED OR EXIST ON ANY DISTRICT EASEMENT OR RIGHT OF WAY WITHOUT WRITTEN APPROVAL BY IRRIGATION DISTRICT. ANY UNAUTHORIZED STRUCTURE WITHIN THE EASEMENT BOUNDARY IS SUBJECT TO IMMEDIATE REMOVAL AT VIOLATOR'S EXPENSE.
- NO UTILITY COMPANY, PUBLIC ENTITY, PARTY OR PERSON IS ALLOWED TO CONNECT TO ANY DISTRICT FACILITY WITHOUT FIRST OBTAINING A PERMIT FROM IRRIGATION DISTRICT. ANY CONNECTION NOT AUTHORIZED BY THIS DISTRICT IS SUBJECT TO IMMEDIATE REMOVAL AT VIOLATOR'S EXPENSE.

METES AND BOUNDS DESCRIPTION

A TRACT OF LAND CONTAINING 30.000 ACRES SITUATED IN THE COUNTY OF HIDALGO, TEXAS, BEING A PART OR PORTION OUT OF BLOCKS 167 AND 168, HILL HALBERT SUBDIVISION, ACCORDING TO THE PLAT THEREOF RECORDED IN VOLUME 1, PAGE 35, HIDALGO COUNTY MAP RECORDS, SAID 30.000 ACRES ARE OUT OF CERTAIN TRACTS CONVEYED TO ELDORA POLO GROUNDS, LLC, BY VIRTUE OF A GENERAL WARRANTY DEED RECORDED UNDER DOCUMENT NUMBER 2619687, A GENERAL WARRANTY DEED RECORDED UNDER DOCUMENT NUMBER 2619894, A GENERAL WARRANTY DEED RECORDED UNDER DOCUMENT NUMBER 2619895, A GENERAL WARRANTY DEED RECORDED UNDER DOCUMENT NUMBER 2619893, AND A GENERAL WARRANTY DEED RECORDED UNDER DOCUMENT NUMBER 2619898, HIDALGO COUNTY OFFICIAL RECORDS, SAID 30.000 ACRES ALSO BEING MORE PARTICULARLY DESCRIBED AS FOLLOWS:

COMMENCING AT A COTTON PICKER SPINDLE FOUND AT THE NORTHWEST CORNER OF BLOCK 167 AND THE NORTHEAST CORNER OF BLOCK 168;

THENCE, S 89° 23' 23" W ALONG THE NORTH LINE OF BLOCK 168, A DISTANCE OF 495.00 FEET TO A NAIL SET, FOR THE NORTHWEST CORNER AND POINT OF BEGINNING OF THIS HEREIN DESCRIBED TRACT;

1. THENCE, N 89° 23' 23" E AT A DISTANCE OF 495.00 FEET PASS A COTTON PICKER SPINDLE FOUND AT THE NORTHWEST CORNER OF BLOCK 167 AND NORTHEAST CORNER OF BLOCK 168, CONTINUING A TOTAL DISTANCE OF 990.00 FEET TO A NAIL SET FOR THE NORTHEAST CORNER OF THIS TRACT;

2. THENCE, S 00° 36' 37" E AT A DISTANCE OF 20.00 FEET PASS A NO. 4 REBAR SET AT THE SOUTH RIGHT-OF-WAY LINE OF ELDORA ROAD, CONTINUING A TOTAL DISTANCE OF 1,320.00 FEET TO A NO. 4 REBAR SET FOR THE SOUTHEAST CORNER OF THIS TRACT;

3. THENCE, S 89° 23' 23" W ALONG THE SOUTH LINES OF SAID BLOCK 167 AND BLOCK 168, AT A DISTANCE OF 495.00 FEET PASS A THE SOUTHWEST CORNER OF SAID BLOCK 168 AND THE SOUTHEAST CORNER OF BLOCK 167, CONTINUING A TOTAL DISTANCE OF 990.00 FEET TO A NO. 4 REBAR SET FOR THE SOUTHWEST CORNER OF THIS TRACT;

4. THENCE, N 00° 36' 37" W AT A DISTANCE OF 1,300.00 FEET PASS A NO. 4 REBAR SET AT THE SOUTH RIGHT-OF-WAY LINE OF ELDORA ROAD, CONTINUING A TOTAL DISTANCE OF 1,320.00 FEET TO THE POINT OF BEGINNING AND CONTAINING 30.000 ACRES GROSS, OF WHICH 0.455 OF ONE ACRE LIES WITHIN THE EXISTING RIGHT-OF-WAY OF ELDORA ROAD, LEAVING A NET OF 29.545 ACRES OF LAND, MORE OR LESS.

MELDEN & HUNT, INC.
TEXAS REGISTRATION F-1435

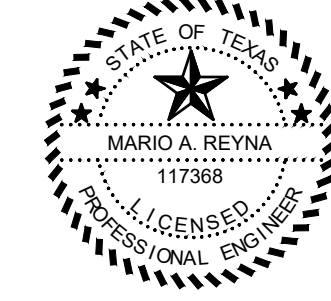

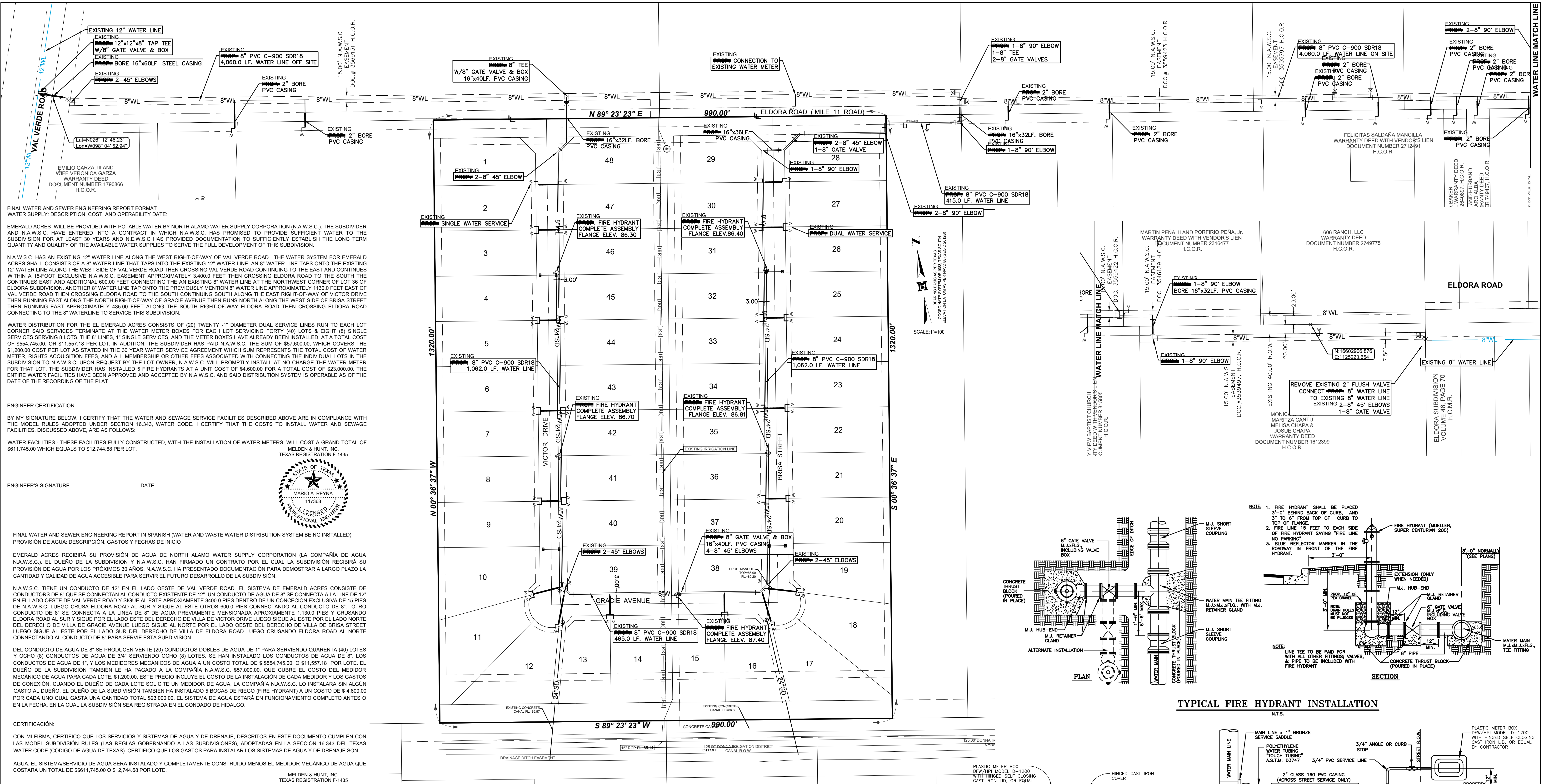

MAP OF WATER DISTRIBUTION SYSTEM
MAPA DE SISTEMA DE DISTRIBUCION DE AGUA
PLAT OF
EMERALD ACRES
 BEING A RE-SUBDIVISION OF 30,000 ACRES
 BEING PART OR PORTION OF BLOCK 167 & 168
 HILL HALBERT SUBDIVISION
 VOLUME 1, PAGES 35, H.C.M.R.

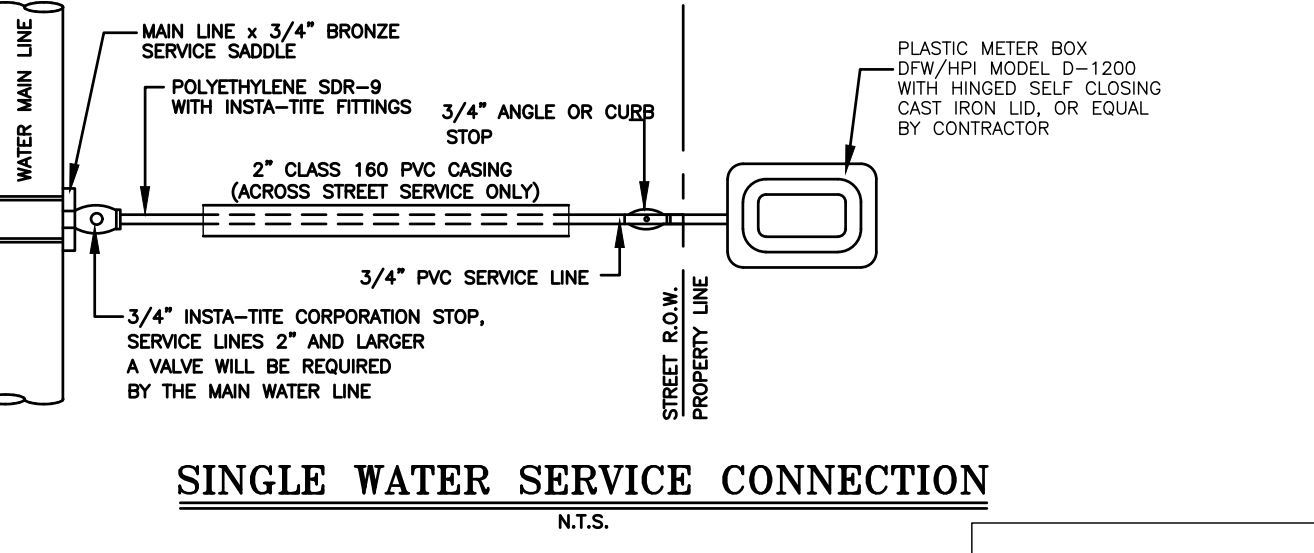
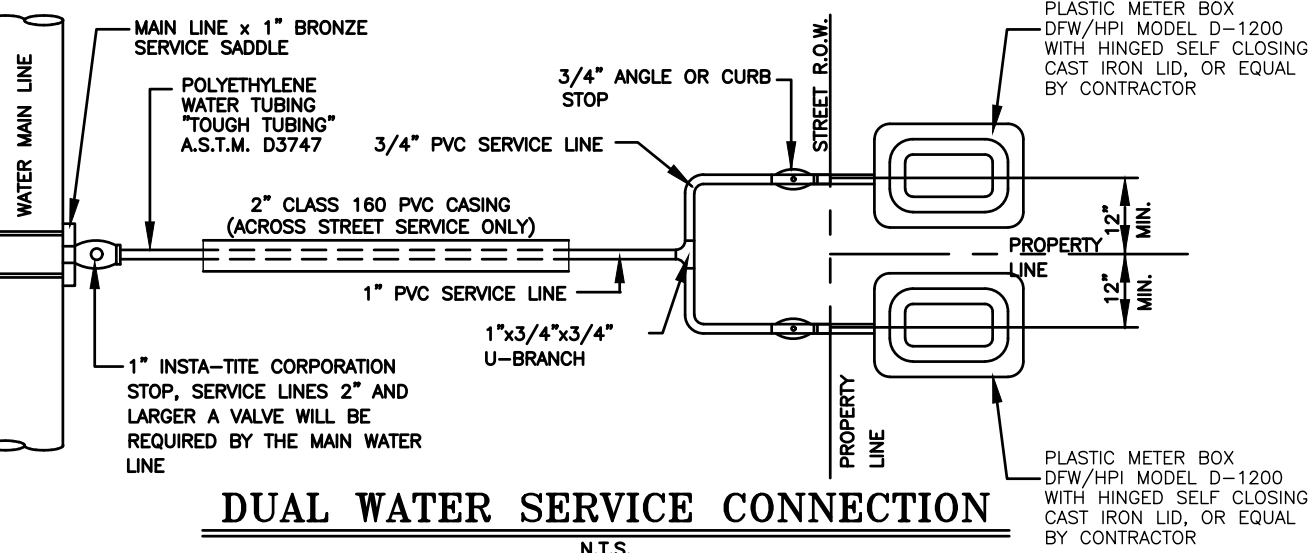
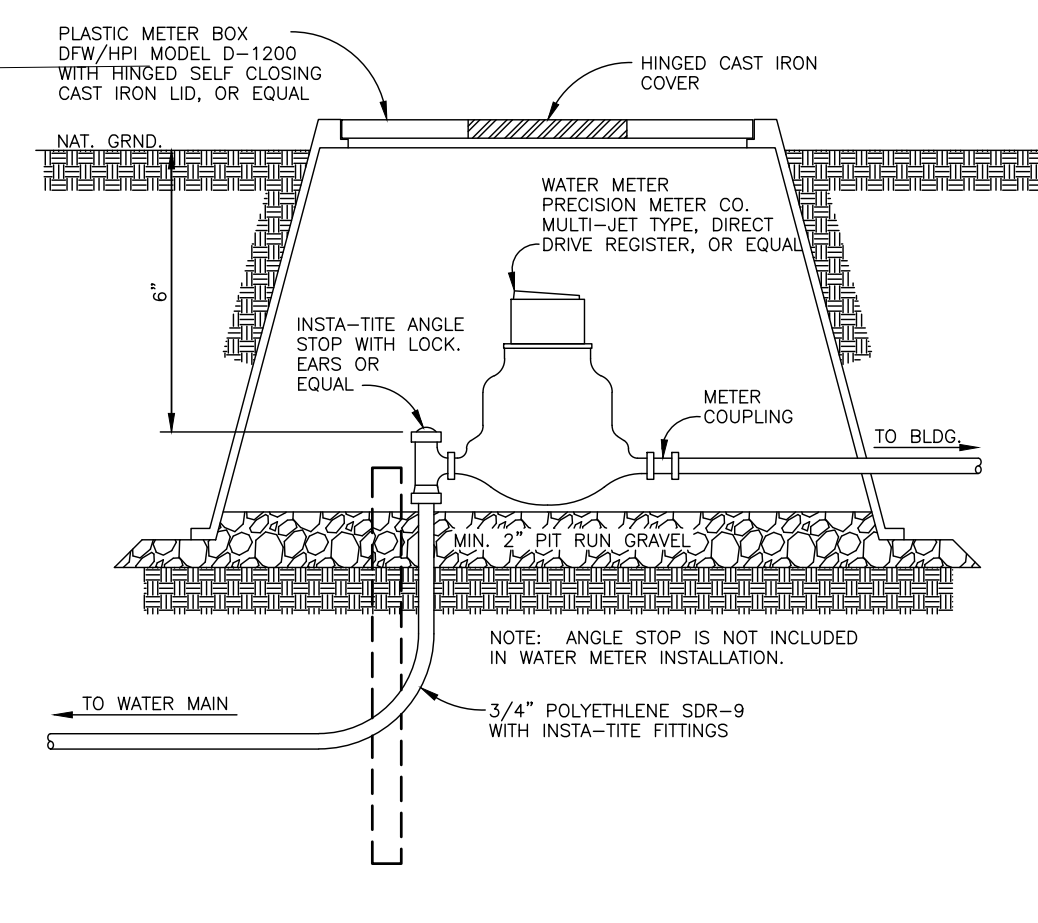
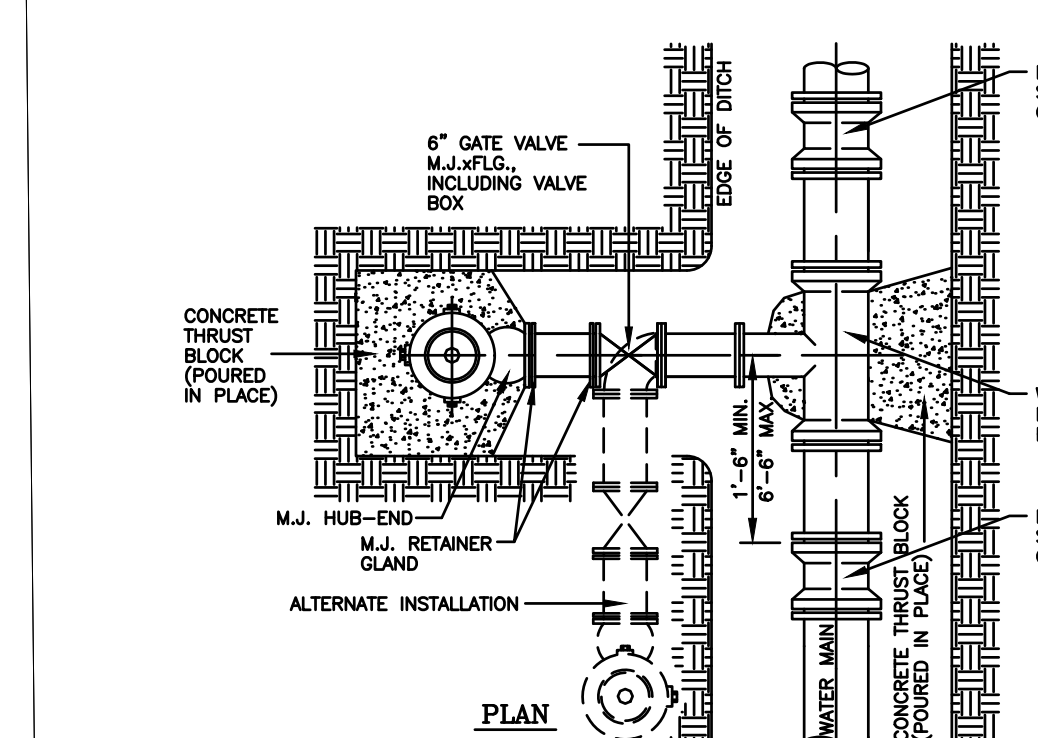
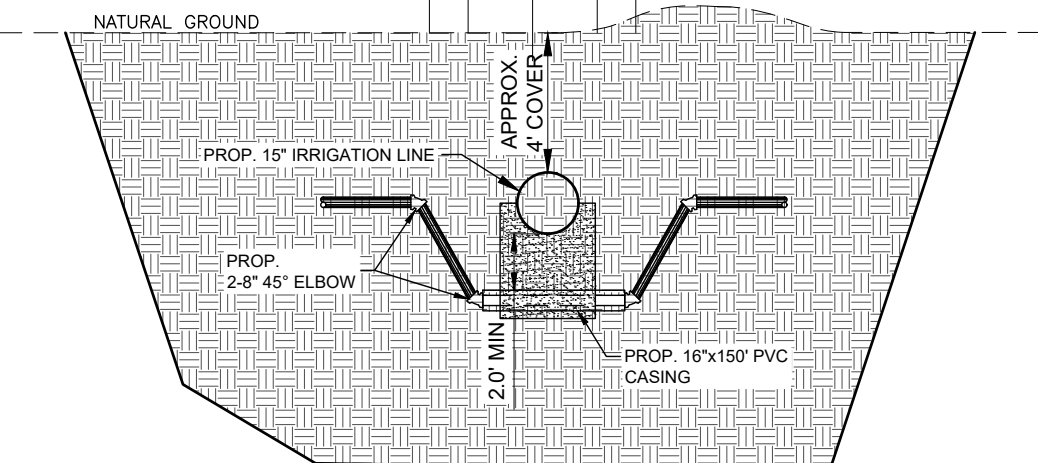

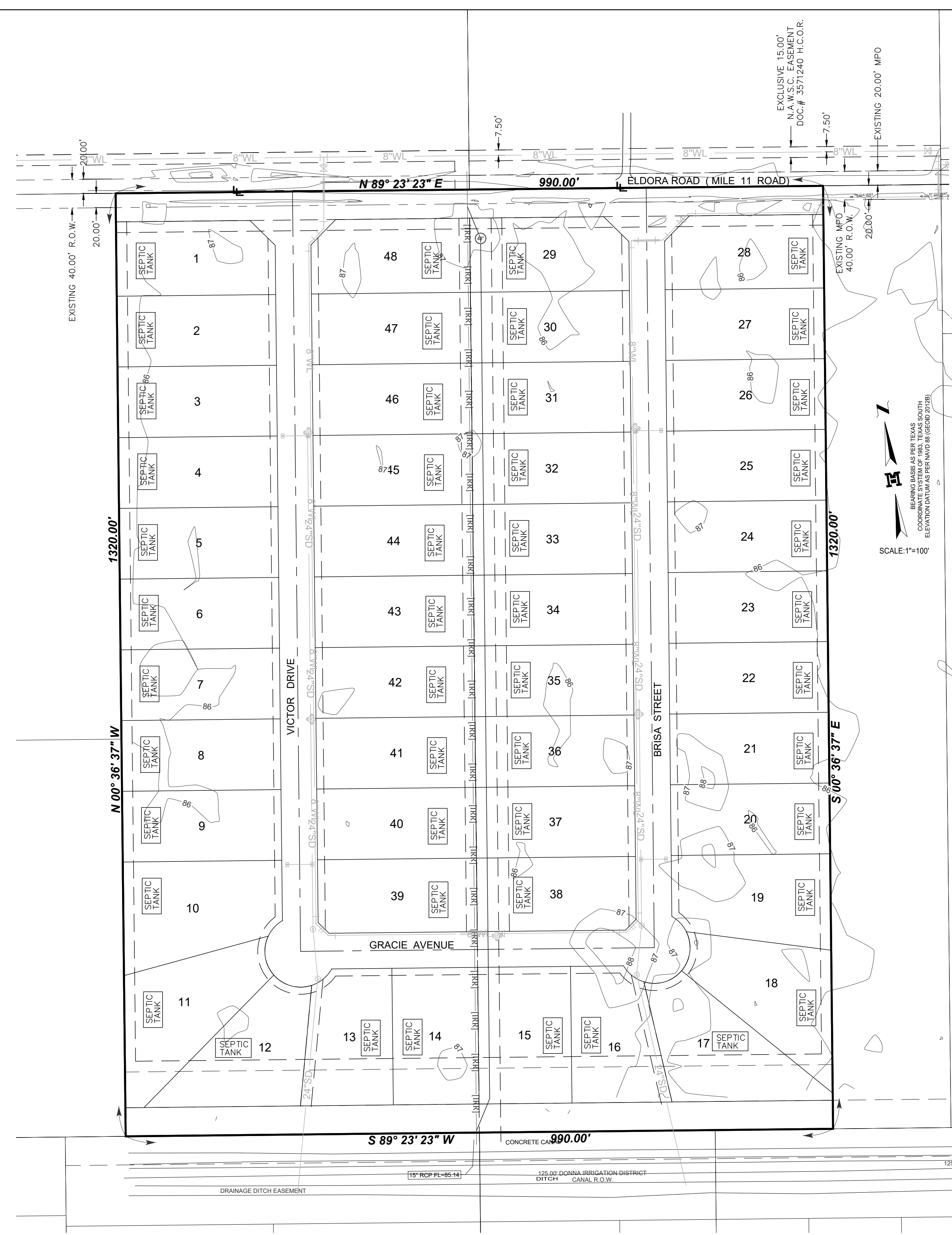

LEGEND
 SEPTIC TANK

SEWAGE FACILITIES DESCRIPTION; COST AND OPERABILITY DATES
 SEWAGE FROM EMERALD ACRES WILL BE TREATED BY INDIVIDUAL ON-SITE SEWAGE FACILITIES ("OSSF") CONSISTING OF A STANDARD DESIGN DUAL COMPARTMENT SEPTIC TANK AND A DRAIN FIELD ON EACH LOT. THE UNDERSIGNED PROFESSIONAL ENGINEER HAS EVALUATED THE SUITABILITY OF THE SUBDIVISION SITE FOR OSSF AND SUBMITTED A REPORT CONCLUDING THAT THE SITE IS SUITABLE FOR OSSF. THE REPORT WAS REVIEWED AND APPROVED BY THE HIDALGO COUNTY HEALTH DEPARTMENT. EACH LOT HAS ADEQUATE AREA FOR A REPLACEMENT DRAIN FIELD.

SOIL EVALUATION REPORT:
 EACH LOT IN THE PROPOSED SUBDIVISION IS AT LEAST 1/2 ACRE IN SIZE. THE NATURAL RESOURCE CONSERVATION SERVICE SOIL SURVEY BOOK INDICATED A HIDALGO SANDY CLAY AND RAYMONDVILLE CLAY LOAM. FOR THE AREA AT LEAST TWO SOIL EXCAVATIONS WERE PERFORMED ON THE SITE, AT OPPOSITE ENDS OF THE PROPOSED DISPOSAL AREA. THE SOIL IS A HIDALGO SANDY CLAY & RAYMONDVILLE CLAY LOAM EXTENDING UP TO 36" BELOW THE BOTTOM OF ANY PROPOSED EXCAVATIONS. THERE IS NO INDICATION OF GROUNDWATER OR A RESTRICTIVE LAYER WITHIN 24" OF BOTTOM OF THE PROPOSED EXCAVATIONS. THE SUBDIVISION DRAINS WELL.

THE COST TO INSTALL A SEPTIC SYSTEM ON AN INDIVIDUAL LOT IS **1,500.00**, INCLUDING THE COST FOR THE REQUIRED PERMIT AND LICENSE. ALL OSSFS HAVE BEEN INSTALLED AS OF THE TIME OF APPLICATION FOR FINAL PLAT APPROVAL AT A TOTAL COST OF **\$72,000.00**. THE HIDALGO COUNTY HEALTH DEPARTMENT HAS INSPECTED AND APPROVED THE INSTALLATION OF ALL OSSF ON JULY 14, 2024.

ENGINEER CERTIFICATION:
 BY MY SIGNATURE BELOW, I CERTIFY THAT THE WATER AND SEWAGE SERVICE FACILITIES DESCRIBED ABOVE ARE IN COMPLIANCE WITH THE MODEL RULES ADOPTED UNDER SECTION 16.343, WATER CODE. I CERTIFY THAT THE COSTS TO INSTALL THE WATER AND THE UNCONSTRUCTED ON-SITE SEWAGE FACILITIES, DISCUSSED ABOVE, ARE AS FOLLOWS:
 SEWAGE FACILITIES - SEPTIC SYSTEM IS ESTIMATED TO COST \$1,500.00 PER LOT (ALL INCLUSIVE), FOR A TOTAL OF \$72,000.00 FOR THE ENTIRE SUBDIVISION.

ENGINEER'S SIGNATURE _____ DATE _____



SUBDIVIDER CERTIFICATION
 1. BY COMPLETING THE IMPROVEMENTS DESCRIBED ON THE PLAT, SUBDIVIDER WILL COMPLY WITH MINIMUM STATE STANDARDS AND THAT (a) WATER QUALITY AND CONNECTIONS INCLUDING WATER METERS AND OR WATER WELLS FOR EACH LOT(S) MEET SUCH STANDARDS AND (b) SEWER CONNECTIONS TO THE LOTS OR SEPTIC TANKS MEET OR WILL MEET SUCH STANDARDS AND WILL BE CONSTRUCTED IN ACCORDANCE WITH STATE AND COUNTY REGULATIONS.

SUBDIVIDER STATEMENT:
 I, We, EVERGREEN LAND & PROPERTIES, LLC, SUBDIVIDER OF EMERALD ACRES, HEREBY CERTIFY SEWER PERMITS HAVE BEEN PAID AND COPIES OF RECEIPTS ARE ON FILE WITH THE HIDALGO COUNTY HEALTH DEPARTMENT THAT ANY ADEQUATE DRINKING WATER SOURCE IS IMMEDIATELY AVAILABLE TO EACH LOT OF THE TYPE, QUALITY & QUANTITY TO ENABLE EACH PERSON PURCHASING A LOT HAVE ADEQUATE WATER TO COMPLY WITH THE REGULATIONS AND THE LAWS OF THE STATE AS REQUIRED BY STATE AND COUNTY REGULATIONS.

SHAVI MAHTANI
 100 E. NOLANA, SUITE 130
 McALLEN, TEXAS 78504

STATE OF TEXAS
 COUNTY OF HIDALGO:

BEFORE ME, THE UNDERSIGNED AUTHORITY, ON THIS DAY PERSONALLY APPEARED SHAVI MAGTANI, KNOWN TO ME THE PERSON WHOSE NAME IS SUBSCRIBED TO THE FOREGOING INSTRUMENT AND ACKNOWLEDGED TO BE THAT HE EXECUTED THE SAME FOR PURPOSED AND CONSIDERATION THEREIN STATED, GIVEN UNDER MY HAND AND SEAL OF OFFICE

THIS THE _____ DAY OF _____, 20____.

NOTARY PUBLIC
 MY COMMISSION EXPIRES _____

DRENAJE; DESCRIPCIÓN, GASTOS Y FECHA DE INICIO PARA FACILITAR EL DRENAJE PARA LA SUBDIVISIÓN
 SE INSTALARA FOSA SÉPTICA EN CADA SOLAR EN EMERALD ACRES. ESTA FOSA SÉPTICA CONSISTE DE UN TANQUE SÉPTICO DE MODELO DUAL Y DE UN CAMPO DE DRENAJE PARA EL SOLAR. EL INGENIERO AUTOR DE ESTE DOCUMENTO HA EVALUADO EL AREA DONDE SE ENCUENTRA LA SUBDIVISIÓN Y HA PREPARADO UN REPORTE QUE CONCLUYE QUE ESTE TERRENO ES ADECUADO PARA ESSAS FOSAS SÉPTICAS (OSSF). EL REPORTE FUE APROBADO POR EL DEPARTAMENTO DE SALUBRIDAD DEL CONDADO DE HIDALGO (HIDALGO COUNTY HEALTH DEPARTMENT) SEGUN EL REPORTE.

SOIL EVALUATION REPORT:
 CADA LOTE EN LA SUBDIVISIÓN MIDE MEDIO ACRE. RECURSOS NATURAL DE CONVEASION DE TIERRAS INDICA HIDALGO ARENOSO FRANCO Y RAYMONDVILLE FRANCO EN ESTA ARIA. SE HICIERON DOS EXCAVACIONES DE EVALUACION EN LUGARES OPUESTOS EN LA SUBDIVISIÓN (EXCAVACIONES ADICIONALES. EL TERRENO ES UNIFORME (TERRENO HIDALGO ARCILLOSO ARENOSO FRANCO Y RAYMONDVILLE FRANCO) Y SE EXTIENDE A 36 PULGADAS BAJO TODAS LAS EXCAVACIONES PROPUESTAS. NO EXISTE EVIDENCIA DE AGUA 24 PULGADAS MAS ARRIBA DE LO MAS BAJO DE LAS EXCAVACIONES PROPUESTAS. EL AGUA EN ESTA AREA FLUYE BIEN.

EL COSTO TOTAL PARA LA INSTALACIÓN DE UN SISTEMA INDIVIDUAL DE FOSAS SÉPTICAS POR SOLAR ES 1,500.00 DOLARES, INCLUYENDO EL COSTO DEL PERMISO REQUERIDO Y LICENCIA. EN ESTOS MOMENTOS TODAS LAS FOSAS SÉPTICAS HAN SIDO INSTALADAS EN EL PROCESO DE LA APROBACIÓN FINAL. A UN COSTO TOTAL DE \$ 72,000.00. EL DEPARTAMENTO DE SALUBRIDAD DEL CONDADO DE HIDALGO HA INSPECCIONADO TODAS LAS FOSAS SÉPTICAS Y AH APROBADO LA INSTALACIÓN DE LAS FOSAS SÉPTICAS DESDE JULIO 14, 2024.

CERTIFICACIÓN:
 CON MI FIRMA, CERTIFICO QUE LOS SERVICIOS Y SISTEMAS DE AGUA Y DE DRENAJE, DESCRITOS EN ESTE DOCUMENTO CUMPLEN CON LAS MODEL SUBDIVISION RULES (LAS REGLAS GOBERNANDO A LAS SUBDIVISIONES), ADOPTADAS EN LA SECCIÓN 16.343 DEL TEXAS WATER CODE (CÓDIGO DE AGUA DE TEXAS). CERTIFICO QUE LOS GASTOS PARA INSTALAR LOS SISTEMAS DE AGUA Y DE DRENAJE SON:

AGUA:
 DRENAJE: SE ESTIMA QUE LA FOSA SÉPTICA COSTARA \$1,500.00 A UN COSTO TOTAL DE \$72,500.00 TODA LA SUBDIVISIÓN.

ENGINEER'S SIGNATURE _____ DATE _____



MAP OF SEPTIC TANK
 MAPA DE SISTEMA DE TANQUE SEPTICOS
 PLAT OF
EMERALD ACRES
 BEING A RE-SUBDIVISION OF 30.000 ACRES
 BEING PART OR PORTION OF BLOCK 167 & 168
 HILL HALBERT SUBDIVISION
 VOLUME 1, PAGES 35, H.C.M.R.

