

**HIDALGO COUNTY PRECINCT #3  
BORDER COLONIA ACCESS PROGRAM  
ROUND III**

**TECHNICAL SPECIFICATIONS FOR TURN KEY**

**BID NO. CAP-17-186-07-12-YSS**

**PALM SUBDIVISION UNIT NO. 2**

**Orange Drive (N – S)  
Orange Drive (E – W)**

**CSJ#3C-1080-834  
CSJ#3C-1080-834**

AT <u>12:00</u>	FILED	<u>P</u>
	O'CLOCK	M
SEP 26 2017		
ARTURO GUAJARDO, JR. COUNTY CLERK HIDALGO COUNTY, TEXAS		
BY _____	<u>NEC</u>	DEPUTY

**JAVIER HINOJOSA ENGINEERING  
416 E. DOVE AVENUE  
McALLEN, TEXAS 78504  
(956) 668-1588  
FAX: (956) 994-8102  
E-mail: javhin@rgv.rr.com  
TBPE FIRM NO. F-1295**

**TABLE OF CONTENTS**  
**CAP-17-186-07-12-YSS**  
**SUBDIVISION NAME**

- 1) Advertisement and Invitation for Bids
- 2) Hidalgo County Revised Legal Notice
- 3) Bidder Acknowledgement
- 3a) Statement of Credentials
- 4) Information for Bidders
- 5) Bid Form
- 6) Bid Bond
- 7) Draft Contract
- 8) Non Collusion
- 9) Payment Bond
- 10) Performance Bond
- 10a) RFB Check list
  
- 11) **Exhibit C**
  - a. Insurance
  
- 12) General Conditions of the Agreement
- 13) Title 29 Labor Standards
- 14) Standard General Condition of Construction Contract
- 15) Supplemental General Condition
  
- 16) **Exhibit A General Notes & Standard Specifications**
  - a. Technical Specifications
  - b. Hidalgo County Specifications as per 340
  - c. Government Specifications & Special Provisions
  
- 17) **Exhibit B**
  - a. Debarment
  - b. W-9
  - c. Bidder/Vendor Application
  - d1. Conflict of Interest Questionnaire
  - e. Sales Tax and Local Sales Tax Certificate
  
- 18) **Exhibit D Border Wage Rates**
  - a. Government code Ch 2258
  - b. Prevailing Wage Rate
  - c. Davis Bacon (USE MOST CURRENT)
  
- 19) **Exhibit E**
  - a. Checklist
  - b. Change Order
  - c. Application for Payment
  - d. Estimate Quantity Update Worksheet
  - e. Schedule of Values
  - f. Contract Time Statement

- g.** Colonia Testing Requirements
- h.** List of Suppliers
- i.** Partial Release of Lien
- j.** Contractor's Affidavit of Payment of Debts and Claims
- k.** Prevailing Wage Rates Certificate Statement
- l.** Certificate of Construction Completion
- m.** Contractor's Affidavit of Release of Liens
- n.** Payment Schedule
- o.** Quantity Work Sheet
- p.** Retainage Release TXDOT Final Inspection letter

**20)** Exhibit G, Title VI Appendices "A" through "E"

**21)** Construction Identification Sign

# REQUEST FOR BIDS

## (Colonia Access Program Project)

TO SUPPLY HIDALGO COUNTY PRECINCT NO.3 with sealed bids on:  
CAP-17-186-07-12-YSS"ROAD & DRAINAGE CONSTRUCTION FOR PALM SUBDIVISION UNIT #2"

A **BIDDER'S BOND** from a reliable surety company licensed to operate in the State of Texas or certified Cashier's Check, payable without recourse to the County of Hidalgo, for the amount of not less than **5%** of the total bid shall accompany the bid as guaranty that, if awarded the contract, the bidder will enter into a contract with the County of Hidalgo. Payment and Performance Bonds shall be executed except in the event into a single payment contract with the County of Hidalgo in lieu of a Performance Bond. In the event the total amount bid is \$25,000 or less, the successful contract has the option to enter into a single payment contract with the County of Hidalgo in lieu of a Payment and Performance Bond.

**Bid Packets** may be obtained from the office of **JAVIER HINOJOSA ENGINEERING, 416 E. DOVE AVENUE McAllen, Texas 78504, Phone No 956-668-1588** for the amount of **\$150.00 each**. General and/or Prime Contractors submitting bids and/or proposals to the County of Hidalgo shall be **non-refundable**.

**PRE-BID CONFERENCE** is scheduled for **WEDNESDAY, JULY 05, 2017 at 2:00P.M.** at **HIDALGO COUNTY NEW ADMINISTRATION BUILDING - PURCHASING DEPARTMENT 2812 S Business Hwy 281, EDINBURG, TEXAS 78539.**

**UPON SUBMITTING SEALED BID**, bidders are required to properly identify (handwritten, typed or printed) sealed envelope and/or packet as follows: Bidder's name and address on the upper left hand corner of the sealed envelope and/or package and Bid No.: **CAP-17-186-07-12-YSS "ROAD & DRAINAGE CONSTRUCTION FOR PALM SUBDIVISION UNIT #2"** on the lower left hand corner of sealed envelopes/and or packets. **OVERNIGHT MAIL MUST ALSO BE PROPERLY LABELED ON THE OUTSIDE OF EXPRESS ENVELOPE OR PACKAGE.**

The sealed bid must contain one (1) original and three (3) copies of bid and must be clearly identified and addressed for delivery to:

**Martha L. Salazar, CPPB, Hidalgo County Purchasing Agent**  
**Hidalgo County Purchasing Department**

**US Postal Mail/Courier Address**

**Hidalgo County New Administration Building**  
**2812 S. Business Hwy 281**  
**Edinburg, Texas 78539**

**Physical Location:**

**Hidalgo County Administration Building**  
**2802 S. Business Hwy. 281**  
**(Southeast of Canton Rd & Business 281)**  
**Edinburg, Texas 78539**

Sealed bids will be accepted until **9:30 a.m. on Wednesday, JULY 12, 2017** at which time they will be opened in the Hidalgo County Purchasing Department Conference Room at **Physical Location: 2802 S. Business Hwy 281, Hidalgo County New Administration Building, Edinburg, Texas 78539.** **NO FACSIMILES OR LATE ARRIVALS WILL BE ACCEPTED. ANY BID RECEIVED AFTER THAT TIME WILL NOT BE OPENED AND WILL BE RETURNED**

The project is to be funded with Border Colonia Access Program funds through Proposition II Funding from the Texas Department of Transportation (Tx.D.O.T.) and Urban County Program CDBG funds.

Attention is called to the fact that not less than, the federally determined prevailing (**Davis-Bacon and Related Acts**) wage rate, as issued and contained in the contract documents, must be paid on this project. In addition, the successful bidder must ensure that employees and applicants for employment are not discriminated against because of race, color, religion, sex, age, disability or national origin.

**BIDS MAY BE HELD** by the County of Hidalgo for a period not to exceed ninety (90) days from the date of the opening of bids for the purpose of reviewing the bids and investigating the qualifications of bidders, prior to awarding of the contract.

**THE COUNTY** reserves the right to refuse and reject any/all bids and to waive any/all formalities or technicalities, or to accept the bids considered the best and most advantageous to the County.

**BY ORDER OF THE COMMISSIONERS COURT OF HIDALGO COUNTY, TEXAS on this 13<sup>TH</sup> DAY OF JUNE, 2017.**

**MARTHA L. SALAZAR, CPPB**  
**HIDALGO COUNTY PURCHASING AGENT**

***REPORT ROAD HAZARDS @ 1-866-HCR-SAFE OR 1-866-427-7233***

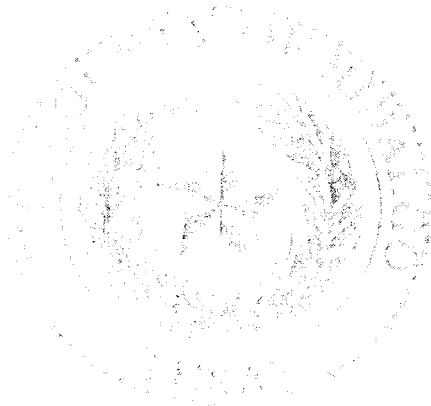

# **REQUEST FOR BIDS (RFB)**

**HIDALGO COUNTY-PCT NO. 3**

**“ROAD & DRAINAGE CONSTRUCTION OF PALM  
SUBDIVISION UNIT #2”**

**Acceptance Date: JULY 12, 2017**

Martha L. Salazar, CPPB, Purchasing Agent  
Hidalgo County Purchasing Department

**Project Buyer Contact Information:**

Yvette Salinas  
Tel: (956) 318-2626 Ext. 4874  
[yvette.salinas@co.hidalgo.tx.us](mailto:yvette.salinas@co.hidalgo.tx.us)

1. Sealed bids will be received for **“HIDALGO COUNTY – PRECINCT NO. 3 -“ROAD & DRAINAGE CONSTRUCTION OF PALM SUBDIVISION UNIT #2”** in accordance with the specifications attached as **Exhibit "A"** hereto. Bids should address all specifications set forth. Bidders may suggest substitutions of features which they feel would be in the best interest of Hidalgo County ("County"). Strong rationale must be presented for any deviation from the specifications. Hidalgo County reserves the right to reject the deviation and its effect on the overall bid.
2. **One (1) original and Three (3) copies** of all bids are required with the bidders name and return address clearly typed and or/printed on upper left hand corner and the proper notation clearly typed/printed on the lower left hand corner of the envelope and/or package: **BID NO.: CAP-17-186-07-12-YSS “HIDALGO COUNTY – PRECINCT NO. 3 -“ROAD & DRAINAGE CONSTRUCTION OF PALM SUBDIVISION UNIT #2”** and at County's Purchasing Department with a physical address: 2802 S. Business 281 and a mailing address: 2812 S. Business Hwy 281, New Administration Building, Edinburg, Texas, **on or before 9:30 A.M, WEDNESDAY, JULY 12, 2017. NO FACSIMILES, EMAILS OR LATE ARRIVALS WILL BE ACCEPTED. ANY RFB RECEIVED AFTER THAT TIME WILL NOT BE OPENED AND WILL BE RETURNED. OVERNIGHT MAIL MUST ALSO BE PROPERLY LABELED ON THE OUTSIDE OF EXPRESS ENVELOPE OR PACKAGE WITH REFERENCE TO “HIDALGO COUNTY – PRECINCT NO. 3 -“ROAD & DRAINAGE CONSTRUCTION OF PALM SUBDIVISION UNIT #2”** Hidalgo County reserves the right to refuse and reject any/all bids and to waive any/all formalities or technicalities, or to accept the bids considered the best and most advantageous to Hidalgo County.

Additionally, all forms listed below must be properly executed and included with your bid:

1. Legal Notice (See page 8);
  2. Bid Page/Form – Procurement Form – Areas of Specialization (See **Exhibit “#5”**);
  3. Insurance pages with Acknowledgment Forms (See **Exhibit “C”**);
  4. Form CIQ-Conflict of Interest Questionnaire (See **Exhibit “D”**)(if applicable);
  5. Vendor Bidder Application & W-9 forms (See **Exhibit “E”**);
  6. Certification Regarding Debarment (See **Exhibit “F”**); and
  7. SAMS.gov Registration Acknowledgement (See Number 18 below).
3. Hidalgo County reserves the right to: A. separate and accept, or eliminate any item(s) listed under this bid that it deems necessary to accommodate budgetary and/or operational requirements; B. reject any or all bids submitted and further reserves the right to design the evaluation criteria to be used in selecting the lowest and best bid for approval; C. award the bid to one bidder or to multiple bidders if the County determines it is in its best interest to do so; D. award the contract to the responsible bidder who submits the lowest and best bid."Lowest and best" means a bid or offer providing the best value considering associated direct and indirect costs, including transport, maintenance, reliability, life cycle, warranties, and customer service after a sale.
  4. The Bidder shall not substitute items named in the bid without the express written consent of Hidalgo County. Failure of the delivered item to perform as specified or failure to meet the stated delivery schedule shall release Hidalgo County from all obligations to the contracting party with regard to the item(s) in question. In such event, County may elect to award the contract to the next-lowest responsible bidder, or to reject all bids and re-advertise.
  5. For work to be performed at a County owned or operated location, each bidder shall, in its sole discretion, visit the job site before preparing the bid and thoroughly familiarize himself/herself with

existing conditions. Bidder should take field dimensions and note all circumstances which affect the dollar amount of the bid.

6. Descriptive specifications are referenced in this document to indicate the general kind and quality of equipment desired by Hidalgo County. Due to various styles and models of equipment, bidders are required to include illustrations, specifications, explanation of warranties, and service data with their bid including catalogue numbers and any necessary references.
7. No bid may be withdrawn within thirty (30) days from the scheduled time to open bids.
8. Proposed prices are to remain firm for a minimum of ninety (90) days after bid opening.
9. Any interpretations, amendments, corrections or changes to this bid document must be in a written addendum and signed by the County Judge or his designee. Addenda will be mailed to all who are known to have received a copy of the Request for Bids. Bidders shall acknowledge receipt of all addenda as a part of their bid.
10. County reserves the right to accept or reject any or all Bids.
11. Costs are to be net F.O.B., County Prepaid.
12. County is exempt from Federal Excise Tax, State Tax and Local Tax. Do Not include tax in cost figure. If it is determined that tax was included in the cost figures it will not be included in the tabulation of any awards. Tax exemption certificates will be furnished upon request.
13. Funds for this procurement have been provided through the County budget for this fiscal year only. County, on an annual basis, has the right to reconsider a contract during the budget process for ensuing years if financial resources of County are insufficient to meet the liabilities of said contract. The award of a bid or contract hereunder will not be construed to create a debt of the County which is payable out of funds beyond the current fiscal year.
14. Upon award and prior to execution of a contract, Sole Proprietorships are required to submit a copy of their social security cards to the Hidalgo County Auditor's Office in order to establish an account with the County. All awarded vendors must submit a completed W-9 and a copy of their Federal ID Number Certificate.
15. DELIVERY INSTRUCTIONS:
  - No deliveries accepted after 3:00 P.M., Monday-Friday.
  - At least seventy two (72) hours prior notice of delivery must be given to Martha L. Salazar, Purchasing Agent before delivery will be accepted.
  - If you need additional information call the office listed below:  
Hidalgo County Purchasing Department  
Martha L. Salazar, Purchasing Agent  
(956) 318-2626
16. BILLING AND PAYMENT INSTRUCTIONS:
  - Invoices must include:
    - a) Name and address of successful bidder
    - b) Name and address of receiving department or official
    - c) Purchase Order Number (if any)

- d) Notation - "HIDALGO COUNTY-RFB NO.: xxxx-xxx-xx-xx-YSS"  
Descriptive information as to the items or services delivered, including product code, item number, quantity, etc.
  - e) Contract number must be indicated on all invoices
- . Discount payments will be considered when offered.
  - . Contact person for Billing and Payment questions:

Hidalgo County Pct No. 1  
Attn: Noemi De Los Rios  
1902 Joe Stephens Ave., Ste. 101  
Weslaco, TX 78599  
(956) 968-8733

17. SCHEDULE OF EVENTS

Bid Opening, 9:30 A.M.	<u>JULY 12, 2017</u>
Award of Contract	<u>                    , 2017</u>
Commence Work or Deliver Products	<u>                                    , 2017</u>

18. BID OR PERFORMANCE BOND AND DEBARMENT CERTIFICATION; PAYMENT UNDER CONTRACT:

- . If the contract proposed is for the construction of public works or is for a contract for goods & services exceeding \$100,000, all bidders shall furnish a good and sufficient bid bond in the amount of five percent of the total contract price. A bid bond must be executed with a surety company authorized to do business in Texas. All bidders are also required to furnish a certification or acknowledgment stating that the contractor or vendor is free from suspension or debarment pursuant to federal regulation 45CFR Part 76. Register at SAMs System for Award Management @ [www.sam.gov](http://www.sam.gov).

- . Together with the signing of a contract or issuance of a purchase order following the acceptance of a bid, and prior to commencement of the actual work, the bidder shall furnish a performance bond to the County for the full amount of the contract, if that contract exceeds \$50,000.

- . If the contract is for \$50,000 or less, no money will be paid to the contractor until completion and acceptance of the work or the fulfillment of the purchase obligation to the County, and, if applicable, the receipt by County of satisfactory evidence that all subcontractors and material men have been paid.

- . If a contract is for the construction, alteration or repair of public buildings or public works, the contractor *shall* provide a payment bond for a contract in excess of Twenty Five Thousand Dollars (\$25,000.00), as required by Tex. Govt. Code Ch. 2253.

For requirements contracts, bond requirements are determined by applying the proposed unit price to the estimated quantities included in the specifications.

19. TITLE VI NOTICE/ NONDISCRIMINATION

- a. "The County of Hidalgo, in accordance with the provisions of Title VI of the Civil Rights Act of 1964 (78 Stat.252, 42 U.S.C. §§2000d to 2000d-4) and the Regulations, hereby notifies all

bidders that it will affirmatively ensure that any contract entered into pursuant to this advertisement, disadvantaged business enterprises will be afforded full and fair opportunity to submit bids in response to this invitation and will not be discriminated against on the grounds of race, color, or national origin in consideration for an award.”

b. The appropriate clauses of Appendices “A” through “E” as delineated in the USDOT Standard Title VI/Nondiscrimination Assurances - Specific Assurances are hereby incorporated by reference as applicable. Title VI Appendices “A” through “E” are attached as **Exhibit “G”**.

c. Bidder will attach all applicable notices to which it is obligated to provide or submit as part of the bid, including Form FHWA 1273 to be submitted by all contractors and subcontractors in relation to construction contracts.

20. ETHICAL STANDARDS:

. It shall be a breach of ethics to offer, give or agree to give any elected official, department head or employee, or former elected official, department head or employee, of the County, or for any elected official, department head or employee or former elected official, department head or employee of the County, to solicit, demand, accept or agree to accept from another person, entity or organization, a gratuity or an offer of employment in connection with any decision, approval, disapproval, recommendation, preparation or any part of a program requirement or purchase request, influencing the content of any specification or procurement standard, rendering of advice, investigation, auditing, or in any other advisory capacity in any proceeding or application, request for ruling, determination, claim or controversy, or other particular matter pertaining to any program requirement or a contract or subcontract, or to any solicitation or proposal therefore pending before any department or agency of the County.

. It shall be a breach of ethics for any payment, gratuity or offer of employment to be made by or on behalf of a subcontractor under a contract to the prime contractor or higher tier subcontractor for any contract for the County, or any person associated therewith, as an inducement for the award of a subcontract or order.

. No public official shall have an interest in a contract awarded hereunder except in accordance with Tex. Loc. Govt. Code Chapter 171.

NOTICE:

ALL COMMUNICATIONS BY A VENDOR TO THE COUNTY, ITS OFFICIALS, AND DEPARTMENT HEADS REGARDING THIS PROCUREMENT SHALL BE DONE THROUGH THE HIDALGO COUNTY PURCHASING DEPARTMENT.

21. DISCLOSURE OF CONFLICT OF INTEREST

. Effective January 1, 2016, Chapter 176 of the Texas Local Government Code requires that any vendor, person, consultant or contractor considering doing business with Hidalgo County (“the County”) to disclose in the Conflict of Interest Questionnaire (the “CIQ”) attached as Exhibit E, the vendor, person, consultant or contractor’s affiliation or business relationship that might cause a conflict of interest with the County. By law, the CIQ must be filed with the Hidalgo County Clerk’s Office no later than the seventh business day after the date the person becomes aware of facts that require that statement to be filed. The disclosure requirement applies to a person or business who contracts or seeks to contract with Hidalgo County for the sale or purchase of property, goods or service. Any purchase order or contract resulting from this process shall be considered null and void if the successful bidder fails to comply with Texas Local Government Code Chapter 176. Vendors, consultants, contractors and others who desire to conduct business with Hidalgo County are encouraged to refer to Texas Local Government

Code Chapter 176 for the details of this law. An offense under Texas Local Government Code Chapter 176 is a Class C Misdemeanor.

**Completed Form CIO must be submitted to the Hidalgo County Clerk's Office located at 100 N. Clossner, Edinburg, Texas 78539 - Hidalgo County Courthouse.**

**COMPLETION AND SUBMISSION OF FORM CIO IS THE SOLE RESPONSIBILITY OF THE PROSPECTIVE RESPONDENT. QUESTIONS REGARDING COMPLIANCE SHOULD BE DIRECTED TO YOUR LEGAL COUNSEL.**

22. **CERTIFICATE OF INTERESTED PARTIES (FORM HB1295)**

As of January 1, 2016, to comply with Texas Government Code Section §2252.908, and the rules issued by the Texas Ethics Commission found in Title 1, Section 46.1, 46.3 and 46.5 of the Texas Administrative Code, we have updated and revised our RFB packet. In accordance with these requirements, business must submit a completed Certificate of Interested Parties Form 1295 to the County before the County may enter into a contract with the business entity. In box 3 of Form 1295, you will provide the RFBProject No. (2016-000), as shown on the packet. Once completed and filed with the Texas Ethics Commission, Form 1295 must be printed and signed in the presence of a notary and submitted to our office either by facsimile transmission to (956) 292-7612 or via email to: [xxxxx.xxxxx@co.hidalgo.tx.us](mailto:xxxxx.xxxxx@co.hidalgo.tx.us). Hidalgo County cannot enter into a contract until Form 1295 is submitted. Therefore, failure to timely submit Form 1295 signed and notarized may result in delay of award. Full instructions for completion and submittal of Form 1295 may be found on the Texas Ethics Commission website:

**<https://www.ethics.state.tx.us/tec/1295-Info.htm>**

**THE AWARDED VENDOR WILL HAVE THIRTY (30) DAYS FROM THE DATE THE HIDALGO COUNTY COMMISSIONER'S COURT APPROVES THIS AGREEMENT TO SUBMIT THE SIGNED NOTARIZED FORM 1295. *HIDALGO COUNTY CANNOT ENTER INTO A CONTRACT UNTIL FORM 1295 IS SUBMITTED.***

23. If, during the life of any contract or bid awarded, the successful bidder's net prices generally available to other customers for items awarded herein are reduced below the contracted price, it is understood and agreed that the benefits of such reduction shall be extended to the County.
24. Bids, and all goods and services provided hereunder, shall comply with all federal, state and local laws concerning this type(s) of goods and/or services.
25. Minimum Standards for Responsible Prospective Bidders: A prospective bidder must affirmatively demonstrate bidder's responsibility. A prospective bidder, by submitting a bid, represents to County that it meets the following requirements:
- Possess or is able to obtain adequate financial resources as required to perform under the bid;
  - Be able to comply with the required or proposed delivery schedule;
  - Have a satisfactory record of performance;
  - Have a satisfactory record of integrity and ethics;
  - Be otherwise qualified and eligible to receive an award.
26. Successful bidder will pay or cause to be paid, without cost or expenses to County, all FICA, FUTA/SUTA and Federal Income Withholding Taxes of all employees, and all wages and benefits as required by Federal or State law. Successful bidder's officers, agents and/or employees will not be entitled to any benefits of an employee or elected official of County, including, but not limited to, benefits associated with County's civil service system.

27. Any contract award to a successful bidder will be in effect until (a) the contract expires, (b) delivery and acceptance of products, and/or performance of services ordered, or (c) terminated by County with thirty days written notice prior to cancellation.
28. County reserves the right to enforce performance of any contract awarded hereunder in any manner prescribed by law or deemed to be in the best interest of the County in the event of breach or default by successful bidder; County reserves the right to terminate any contract immediately in the event a successful bidder fails to:
  - A. Meet schedules;
  - B. Pay any required fees or taxes; or
  - C. Otherwise perform in accordance with the specifications.
29. Successful bidder shall defend, indemnify and save harmless County and all its elected officials, officers, agents and employees from all suits, actions, or other claims of any character, name and description brought for or on account of any injuries or damages received or sustained by any person, persons, or property on account of any negligent act or fault of the successful bidder, or of any agent, employee, subcontractor or supplier of successful bidder in the execution of, or performance under, any contract which may result from bid award or which arises from any event or casualty happening on or within County premises themselves or happening upon or in any halls, elevators, entrances, stairways or approaches of or to such County facilities. Successful bidder shall pay any judgment with costs which may be obtained against County growing out of such injury or damages, and shall, upon request, provide a defense to County by counsel reasonably acceptable to County. Successful bidder's indemnity hereunder shall include, but is not limited to, claims relating to patent, copyright or trademark infringement, and the like, arising out of the goods and services provided by successful bidder.
30. Successful bidder shall warrant that all items/services shall conform with the specifications and/or all warranties provided under the Uniform Commercial Code and be free from all defects in material, workmanship and the like. Items supplied under a contract pursuant to this Request for Bids shall be subject to County's approval. Items found to be defective or not meeting specifications shall be replaced by successful bidder within two business days at no expense to County. Items not picked up within one (1) week after notification shall be deemed a donation to County and may be used or disposed of at County's discretion and without waiver of any other rights of County as to the item's nonconformity.
31. This document and any disputes arising hereunder shall be governed and construed according to the laws of the State of Texas, and will be performable exclusively in Hidalgo County, Texas.
32. The successful bidder shall not assign, sell, transfer or convey its rights under any awarded contract, in whole or in part, without the prior written consent of County.

Request for Bid  
for  
**HIDALGO COUNTY**  
**BCAP Pct No. 3**  
**“HIDALGO COUNTY – PRECINCT NO. 3 -“ROAD & DRAINAGE CONSTRUCTION OF PALM**  
**SUBDIVISION UNIT #2”**  
**BID NO.: CAP-17-186-07-12-YSS**

To: Martha L. Salazar, CPPB, Purchasing Agent  
Physical Address: 2802 S. Business Hwy. 281 -New Administration Building  
Mailing/Postal Address: 2812 S. Business Hwy. 281  
Edinburg, Texas 78539

In accordance with the Specifications, and subject to all laws and regulations of the United States and state and local laws, the undersigned bidder proposes and commits to furnish all labor, equipment, material, software and services as set forth in the documents hereinbefore mentioned. The undersigned bidder further agrees, upon acceptance of its bid, to execute a contract and/or Purchase Order issued by Hidalgo County for performing and completing the work described in the Specifications within the time stated and for the prices proposed in the documents attached hereto and made a part hereof.

Bidder acknowledges receipt of all of the pages of the documents referenced in the Invitation to Bid Checklist presented in connection with this procurement. Bidder understands that Hidalgo County reserves the right to reject any or all bids and further reserves the right to design the evaluation criteria to be used in selecting the lowest and best bid.

Bidder agrees that this bid shall be good and may not be withdrawn for a period of ninety (90) calendar days after the scheduled closing time for receiving bids, as contained in the Specifications.

Respectfully submitted,

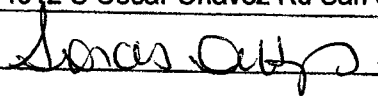
Bidder: Five Star Galaxy Construction LLC  
Address: 4012 S Cesar Chavez Rd San Juan, Tx 78589  
By:   
Printed Name: Sorais De Hoyos  
Title: Managing Member

STATEMENT OF CREDENTIALS

1. GENERAL: In order to assist the Owner in determining the ability of each Bidder to properly fulfill the requirement of this proposed contract, the Bidder will complete the following items. All questions must be answered and the data given must be clear and comprehensive. This statement must be notarized. If necessary, questions may be answered on separate attached sheets. The Bidder may submit any additional information he/she desires.

Name of Bidder: Five Star Galaxy Construction LLC

Address: 4012 S Cesar Chavez Rd San Juan, TX 78589

Date Organized: 03/15/2015 Date Incorporated: 04/01/2015

Office Number: (956) 212-8226 Fax Number: (956) 800-4551

Number of years in business under present name: 2 years

Type of work performed by your company: Sitework & Paving

Have you ever failed to complete any work awarded to you? No

Have you ever defaulted on a contract? No

2. EXPERIENCE: The Bidder will give below a list of similar projects which he/she has completed within the last five (5) years.

1. Owner: Hidalgo County Precinct 1

Address: Old La Blanca Rd Donna, TX

Ph/Fx Number: (956) 502-5426 Email:

Scope of Work Description: Sitework & Paving

Date Completed: Oct 2016 Total Cost: \$318,801.00

\*\*\*\*\*

2. Owner: RHTJ Properties

Address: Canton & Valverde Rd Donna, Tx

Ph/Fx Number: (956) 464-4710 Email: \_\_\_\_\_

Scope of Work Description: Sitework & Paving

Date Completed: 02/2017 Total Cost: \$274,114.00

\*\*\*\*\*

3. Owner: City of Donna

Address: 8000 International Bridge

Ph/Fx Number: (956) 926-5041 Email: \_\_\_\_\_

Scope of Work Description: Demolition & Paving

Date Completed: 05/2017 Total Cost: \$53,862.00

\*\*\*\*\*

4. Owner: City of Palview

Address: 400 W Veterans Blvd Palmview, TX 78573

Ph/Fx Number: (956) 432-0300 Email: \_\_\_\_\_

Scope of Work Description: Paving & Drainage Improvements

Date Completed: 03/2016 Total Cost: \$14,485.00

\*\*\*\*\*

5. Owner: Kim Family Property Trust

Address: Alondra La Blanca, Tx

Ph/Fx Number: (956) 381-0981 Email: \_\_\_\_\_

Scope of Work Description: Sitework & Paving

Date Completed: 08/2016 Total Cost: \$100,061.00

\*\*\*\*\*

**3. CONTRACTS ON HAND:** The Bidder shall provide below a list of any contracts/projects he/she currently has on hand:

---

---

---

---

---

---

---

---

---

---

---

---

**4. SUBCONTRACTORS:** List any subcontractors you propose to use on the Hidalgo County's project that will comprise at least 20% of the total project cost. Use additional page if necessary. This information is considered preliminary and may be revised prior if bid is awarded and re-submitted during the pre-construction phase. However, it is expressly understood that the use of any subcontractor other than those listed with bid shall require written approval from Hidalgo County.

Failure to submit the information as required may result in a disqualification of your bid.

---

We will not be using any Subcontractors on project.

---

---

---

---

---

---

---

---

---

---

- 5. PERFORMANCE OF WORK BY BIDDER:** Except as otherwise provided, the general contractor/bidder shall perform no more than eighty percent (80%) of the work with his own organization, and no less than twenty percent (20%) of the work may be subcontracted.

The organization of the specifications into divisions, sections, articles, etc., and the arrangement and titles of project drawings shall not control the Bidder in dividing the work among subcontractors or in establishing the extent of work to be performed by any trade.

Awarded bidder shall assign a project superintendent who is directly employed by the Bidder, that superintendent will be required to be on the job on a daily basis. No subcontractors will be allowed to act as project superintendents at any point during the construction of said project.

Bidder shall have a significant business presence with the Rio Grande Valley Area, the business must be headquartered in either Hidalgo, Cameron, or Starr County or a local office must be located in either of the three counties (Hidalgo, Cameron, Starr) with at least thirty percent (30%) of the total company workforce employed at the local office. County reserves the right to request payrolls and any necessary documentation to confirm that the local office meets these requirements.

Bidders shall carefully examine the plans, specifications, and other documents, visit the site of the work, and fully inform themselves as to all conditions and matters which can affect the work or cost thereof. Should the bidder find discrepancies in, or omissions from the plans, specifications, or other documents, or should he/she be in doubt as their meaning, he/she should at once notify the Engineer and obtain clarification by addendum prior to submitting any bid.

Bidder hereby certifies that said company carried liability coverage and workers' compensation insurance coverage that meets the requirements set forth in this Request for Bids/Proposals when performing work on this project for Hidalgo County.

Furthermore, Bidder certifies that any subcontractor on the project shall provide the said company with a certificate relating that all employees of the subcontractor also are provided with workers' compensation insurance coverage. Bidder will provide copies of all of these certificates to Hidalgo County during the course of the project for all subcontractors working on the project.

All subcontractors must comply with federally determined prevailing Davis-Bacon and Related Acts wage rate.

Executed this 10<sup>th</sup> day of July, 20 17.

By Lorena Ortiz

Title Managing Member

Subscribed and sworn to me this 10<sup>th</sup> day of 2017.

By: Krista Garcia

Notary Public in and for Hidalgo County, Texas

My commission expires Feb 13, 2018



# INFORMATION FOR BIDDERS

## 1. Receipt and Opening of Bids

The Hidalgo County Pct # 3 (herein called the "Owner"), invites bids on the form attached hereto, all blanks of which must be appropriately filled in. Bids will be received by the Owner at the Hidalgo County Purchasing department until Wednesday, July 12, 2017 at 9:30 a.m. and then at said office publicly open and read aloud. The envelopes containing the bids must be sealed, addressed to Martha L. Salazar, Hidalgo County Purchasing Agent at 2812 S Business 281, Edinburg, Texas 78539 and designated as Bid for Hidalgo County Pct # 3 Border Colonia Access Program.

The owner may consider informal any bid not prepared and submitted in accordance with provisions hereof and may waive any informalities or reject any and all bids. Any bid may be withdrawn prior to the above scheduled time for the opening of bids or authorized postponement thereof. Any bid received after the time and date specified shall not be considered. No bidder may withdraw a bid within 60 days after the actual date of the opening thereof.

## 2. Preparation of Bid

Each bid must be submitted on the prescribed forms and Certification by Bidder (contractor), concerning Labor Standards and Prevailing Wage Requirements. All blank spaces for bid prices must be filled in, in ink or typewritten, in both words and figures, and the foregoing Certificates must be fully completed and executed when submitted.

Each bid must be submitted in a sealed envelopes bearing on the outside the name of the bidder, his address, and the name of the project for which the bid is submitted. If forwarded by mail, the sealed envelope containing the bid must be enclosed in another enveloped addressed as specified in the bid form.

## 3. Subcontracts

The bidder is specifically advised that any person, firm, or other party to whom is proposed to ward a subcontract under this contract –

- a Must be acceptable to the Owner after verification of the current eligibility status, and,
- b Approval of the proposed subcontract award cannot be given by the Owner unless and until the proposed subcontractor has submitted the Certification and/or other evidence showing that it has fully complied with any reporting requirements to which it is or was subject. Although the bidder is not required to attach such Certification by proposed subcontractors to his bid, the bidder is here advised of this requirement so that appropriate action can be taken to prevent subsequent delay in subcontract awards.

## 4. Telegraphic Modification

Any bidder may modify his bid by telegraphic communication at any time prior to the scheduled closing time for receipt of bids, provided such telegraphic communication is received by the Owner prior to the

closing time, and provided further, the Owner is satisfied that a written confirmation of the telegraphic modification over the signature of the bidder was mailed prior to the closing time. The telegraphic communication should not reveal the bid price but should provide the additional or subtraction or other modification so that the final prices or terms will not be known by the Owner until the sealed bid is opened. If written confirmation is not received within two days from the closing time, no consideration will be given to the telegraphic modification.

#### 5. Method of Bidding

The Owner invites the following bid(s):      Border Access Colonia Project Round III  
Grant No. 3C-1080-834  
Subdivision Name **Palm Subdivision Unit #2**

#### 6. Qualifications of Bidder

The Owner may make such investigations as he deems necessary to determine the ability of the bidder to perform the work, and the bidder shall furnish to the Owner all such information and data for this purpose as the Owner may request, the Owner reserves the right to reject any bid if the evidence submitted by, or investigation of, such bidder fails to satisfy the Owner that such bidder is properly qualified to carry out the obligations of the contract to complete the work contemplated therein. Conditional bids will not be accepted.

#### 7. Bid Security

Each bid must be accompanied by certified check of the bidder, or a bid bond prepared on the form of bid bond attached hereto, duly executed by the bidder as principal and having as surety thereon a surety company approved by the Owner, in the amount of 5% of the bid. Such checks or bid bonds will be returned to all except the three lowest bidders within three days after the opening of bids, and the remaining checks, or bid bonds will be returned promptly after the Owner and the accepted bidder have executed the contract, or if no award has been made within 60 days after the date of the opening of bids, upon demand of the bidder at any time thereafter, so long as he has not been notified of the acceptance of his bid.

#### 8. Liquidated Damages for Failure to enter into Contract

The successful bidder, upon his failure or refusal to execute and deliver the contract and bonds required within 10 days after he has received notice of the acceptance of his bid, shall forfeit to the Owner, as liquidated damages for such failure or refusal, the security deposited with his bid.

#### 9. Time of Completion and Liquidated Damages

Bidder must agree to commence on or before a date to be specified in a Written "Notice to Proceed" of the Owner and to fully complete the project within **120 consecutive calendar days** thereafter. Bidder must agree also to pay as liquidated damages, the sum of **\$250.00** for each consecutive calendar day thereafter as hereinafter provided in the General Conditions.

## **10. Condition of Work**

Each bidder must inform himself fully of the conditions relating to the construction of the project and the employment of labor thereon. Failure to do so will not relieve a successful bidder of his obligation to furnish all material and labor necessary to carry out the provisions of his contract. Insofar as possible the contractor, in carrying out his work, must employ such methods or means as will not cause any interruption of or interference with work of any other contractor.

## **11. Addenda and Interpretations**

No interpretation of the meaning of the plans, specifications or other pre-bid documents will be made to any bidder orally.

Every request for such interpretation should be in writing addressed to **Javier Hinojosa Engineering, 416 E. Dove Avenue, McAllen, Texas 78504 Attn: Mr. Javier Hinojosa, P.E.**, and to be given consideration must be received at least five days prior to the date fixed for the opening of bids. Any all such interpretations and any supplemental instructions will be in the form of written addenda to the specifications which, if issued, will be mailed by certified mail with return receipt requested to all prospective bidders (at the respective addresses furnished for such purposes), not later than three days prior to the date fixed for the opening of bids. Failure of any bidder to receive any such addendum or interpretation shall not relieve such bidder from any obligation under his bid as submitted. All addenda so issued shall become part of the contract documents.

## **12. Security for Faithful Performance**

Simultaneously with his delivery of the executed contract; the contractor shall furnish a surety bond or bonds as security for faithful performance of this contract and for the payment of all persons performing labor on the project under this contract and furnishing materials in connection with this contract, as specified in the General Conditions included herein. The surety on such bond or bonds shall be a duly authorized surety company satisfactory to the Owner.

## **13. Power of Attorney**

Attorney-in-fact who sign bonds or contract bonds must file with each bond a certified and effectively dated copy of their power of attorney.

## **14. Notice of Special Conditions**

Attention is particularly called to those parts of the contract documents and specification which deal with the following;

- a Inspection and testing of materials
- b Insurance requirements
- c Wage rates
- d States allowances

## **15. Laws and Regulations**

The bidder's attention is directed to the fact that all applicable State laws, municipal ordinances, and the rules and regulations of all authorities having jurisdiction of the project shall apply to the contract throughout, and they will be deemed to be included in the contract the same as though herein written out in full.

**16. Method of Award – Lowest Qualified Bidder**

If at the time this contract is to be awarded, the lowest base bid submitted by a responsible bidder does not exceed the amount of funds then estimated by the Owner as available to finance the contract the contract will be awarded on the base bid only. If such bid exceeds such amount, the Owner may reject all bids or may award the contract on the base bid combined with such deductible alternates applied in numerical order in which they are listed in the form of Bid, as produces a net amount which is within the available funds.

**17. Obligation of Bidder**

At the time of the opening of bids each bidder will be presumed to have inspected the site and to have read and to be thoroughly familiar with the plans and contract documents (including all addenda). The failure or omission of any bidder to examine any form, instrument or document shall in no way relieve any bidder from any obligation in respect of his bid.

**Supplement to Form HUD-4238-B®  
INFORMATION FOR BIDDERS**

**18. SAFETY STANDARDS AND ACCIDENTS PREVENTION**

With respect to all work performed under this contract, the contractor shall:

- 1 Comply with the safety standards provision of applicable laws, building and construction codes and the "Manual of Accident Prevention in Construction" published by the Associates General Contractors or America, the requirements of the Occupational Safety and Health Act of 1970 (Public Laws 91-596), and the requirements of Title 29 of the Code of Federal Regulations, Section 1518 as published in the "Federal Register", Volume 36, No 75, Saturday, April 17, 1971.
- 2 Exercise every precaution at all times for the prevention of accidents and the protection of persons (including employees) and property.
- 3 Maintain at his office or other well known place at the job site, all articles necessary for giving first aid to the injured, and shall make standing arrangements for the immediate removal to a hospital or a doctor's care of persons (including employee), whom may be injured on the job site. In no case shall employee be permitted to work at a job site before the employer has made a standing arrangement for removal of injured person to a hospital or a doctor's care.

## **SPECIAL PROVISIONS**

1. The County of Hidalgo reserves the right to partially award the contract in order to meet the budget.
2. It shall be the Contractor's responsibility to locate underground utilities, whether shown or not shown on the drawings, sufficiently in advance of operations to preclude damage to same.
3. Water, sewer, or other utility serves shall not be interrupted. Any damages to existing utilities will be Contractor's responsibility.
4. In the event of damage to underground facilities, whether shown or not shown in the drawings, the Contractor shall make the necessary repairs to place the facilities back in service at no increase in the Contractors price and all such repairs shall conform to the requirements of the company or agency servicing the facility
5. The Contractor shall exercise extra care to prevent damage to all other structures in the area including, fence, roads, pipelines, utilities, etc., whether publicly or privately owned.
6. Until acceptance by the Engineer of any part or all of the construction, as provided for in the plans and these specifications, it shall be under the charge and care of the contractor, and he shall take every necessary precaution against injury or damage to any part of the work. The Contractor shall rebuild, repair, restore and make good, at his own expense, all injuries or damage to any portion of the work before its completion and acceptance.
7. In case the Contractor deems extra compensation is due him for proposed work not covered in the contract, the Contractor shall notify the Engineer in writing of his claim for such extra compensation before he begins the work. Failure on the part of the Contractor to give such notification shall constitute a waiver of claim for such extra compensation. The Contractor shall not proceed until a written Change Order is approved by the Owner, Engineer, and Contractor.
8. Prospective bidders should make a careful examination of the projects sites.
9. Contractor shall review his overall method and schedule of construction with the County Prior to construction for proper coordination of inspection.
10. No open trenches or excavation shall be left open overnight.

# BID FORM

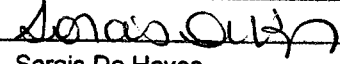
Company Name:	Five Star Galaxy Construction LLC
Signature:	
Printed Name:	Sorais De Hoyos

**BID FORM**  
**HIDALGO COUNTY PRECINCT NO. 3**  
**BORDER COLONIA ACCESS PROJECT**  
**CAP-17-186-07-12-YSS**  
**ROAD AND DRAINAGE CONSTRUCTION FOR PALM SUBDIVISION UNIT NO. 2**

**BID ITEMS FOR ROAD CONSTRUCTION**

TXDOT Item No.	Est Quantity	Unit	Item Description	Unit Bid Price In Words	Unit Price In Figures	Total Extension In Figures
----------------	--------------	------	------------------	-------------------------	-----------------------	----------------------------

**PAVING**

100	14.01	STA	Preparing ROW	One hundred Twenty Zero	Dollars Cents	\$ 120.00	\$ 1,681.20
247	4,976	SY	8" Flex Base (Compl In Place) (TY E GR 4)	Five Zero	Dollars Cents	\$ 5.00	\$ 24,880.00
251	4,976	SY	Reworking BS Material (DC) (TY D 6")	Two Zero	Dollars Cents	\$ 2.00	\$ 9,952.00
310	996	GAL	Asphalt Matrl (MC-30)	Eight Zero	Dollars Cents	\$ 8.00	\$ 7,968.00
340	4,296	SY	D-GR HMA(SQ) TY-D SAC-B PG 64-22 (1 1/2")	Eight Fifty	Dollars Cents	\$ 8.50	\$ 36,516.00
502	4.0	MO	Barricades, Sign and Traffic Handling	Five hundred Zero	Dollars Cents	\$ 500.00 5.00 SDH	\$ 2,000.00
530	60	SY	Turnouts (ASPH-CONC- PAV)(PB-2)	Twenty-Seven Zero	Dollars Cents	\$ 27.00	\$ 1,620.00
530	139	SY	Driveway (ASPH-CON-PAV) (PB-1)	Twenty-Seven Zero	Dollars Cents	\$ 27.00	\$ 3,753.00
530	553	SY	Driveway (Concrete 3000 PSI)	Thirty-Six Fifty	Dollars Cents	\$ 38.50	\$ 20,184.50

Roadway Subtotal	\$ 108,554.70
------------------	---------------

**OPENED**

9:41 7-12-17

**Witnessed**

Company Name:	Five Star Galaxy Construction LLC
Signature:	<i>Sorais De Hoyos</i>
Printed Name:	Sorais De Hoyos

**DRAINAGE**

464	648	LF	15" HPP Culvert Pipe	Twenty-Five	Dollars	\$	25.00	\$	16,200.00
				Zero	Cents				
464	70	LF	18" RC Culvert Pipe	Thirty-Five	Dollars	\$	35.00	\$	2,450.00
				Zero	Cents				
464	2	EA	Safety End Treatment (18")	Eight Hundred	Dollars	\$	800.00	\$	1,600.00
				Zero	Cents				
506	160	LF	Temporary Sediment Control Fence	Three	Dollars	\$	3.00	\$	480.00
				Zero	Cents				
506	160	LF	Temporary Sediment Control Fence (Remove)	Two	Dollars	\$	2.00	\$	320.00
				Zero	Cents				

Drainage	\$
Subtotal	21,050.00

<b>Bid Total</b>	<b>\$ 129,604.70</b>
------------------	----------------------

BIDDER/COMPANY NAME: Five Star Galaxy Construction LLC  
 AUTHORIZED SIGNATURE: *Sorais De Hoyos*  
 PRINTED NAME: Sorais De Hoyos  
 TITLE: Managing Member

**OPENED**  
9:11 7-12-17

**Witnessed**

*[Signature]*

Company Name:	<u>Five Star Galaxy Construction</u>
Signature:	<u><i>Sorais De Hoyos</i></u>
Printed Name:	<u>Sorais De Hoyos</u>

**CONTINUATION OF BID PACKAGE**

The undersigned Bidder agrees to commence work after written notice to commence work and to substantially complete the work on which he has bid within 120 **calendar days** as provided in Article 18 of the General Conditions of the Agreement.

Enclosed with this Proposal is a Cashier's check or Certified Check for \_\_\_\_\_ Dollars ( \_\_\_\_\_ ) or a Bid Bond in the Sum of \_\_\_\_\_ Dollars ( \_\_\_\_\_ ), which is agreed shall be collected and retained by the Owner under the Conditions hereof within ten (10) days after the date this proposal is accepted; then otherwise the said bond or check shall be returned to the undersigned upon demand.

Receipts of the following Addenda on these dates shown is acknowledged:

#1	DATE	ACKNOWLEDGE	#2	DATE	ACKNOWLEDGE
#3			#4		

Respectfully submitted,

Five Star Galaxy Construction LLC  
Name of Firm

By: [Signature] 07/11/2017  
Signature Date

**THIS PROPOSAL MUST BE  
SIGNED BY AN OFFICER OR  
REPRESENTATIVE DULY  
AUTHORIZED BY THE BIDDER**

Managing Member  
Title

4012 S Cesar Chavez Rd  
Address

San Juan, TX 78589

(956) 212-8226  
Telephone Number

(Seal, if Bid is by a Corporation)

Attest: [Signature]

Company Name:	Five Star Galaxy Construction
Signature:	[Signature]
Printed Name:	SORCUS DE HUYAS

## BID BOND

Bond No. CNB-24777-00

KNOW ALL MEN BY THESE PRESENTS:

THAT we, Five Star Glaxy Constructin, LLC, as Principal, hereinafter called the Principal, and INSURORS INDEMNITY COMPANY, Waco, Texas, as Surety, hereinafter called the Surety, are held and firmly bound unto Hidalgo County Precinct 3, as Obligee, hereinafter called the Obligee, in the amount of 5 % of the amount of this bid not to exceed 5% of the Greatest Amount Bid Dollars (\$ 5% of G.A.B ), for the payment of which sum well and truly to be made, the said Principal and the said Surety, bind ourselves, our heirs, executors, administrators, successors and assigns, jointly and severally, firmly by these presents.

WHEREAS, the principal has submitted a bid for

CAP-17-186-07-12-YSS,Road & Drainage Construction For Palm Subdiviaionj Unit #2

NOW, THEREFORE, If the contract be timely awarded to the Principal and the Principal shall within such time as specified in the bid, enter into a contract in writing and give bond with good and sufficient surety, or, in the event of the failure of the Principal to enter into such Contract and give such bond or bonds; if the Principal shall pay to the Obligee the difference not to exceed the penalty hereof between the amount specified in said bid and such larger amount for which the Obligee may in good faith contract with another party to perform the work covered by said bid, then this obligation shall be null and void, otherwise to remain in full force and effect

PROVIDED, HOWEVER, neither Principal nor Surety shall be bound hereunder unless Obligee prior to execution of the final contract shall furnish evidence of financing in a manner and form acceptable to Principal and Surety that financing has been firmly committed to cover the entire cost of the project.

SIGNED, SEALED AND DATED this 12th day of July, 2017 .

Principal:

Five Star Glaxy Constructin, LLC

By: Josais Ochoa <sup>(Seal)</sup> Managing Member  
(title)

Surety:

INSURORS INDEMNITY COMPANY

By: Omar Villarreal <sup>(Seal)</sup>  
Omar Villarreal, Attorney-in-Fact

## IMPORTANT NOTICE - AVISO IMPORTANTE

To obtain information or make a complaint:

You may call Insurors Indemnity Company's toll-free telephone number for information or to make a complaint at:

1-800-933-7444

You may also write to Insurors Indemnity Company at:

P.O. Box 2683  
Waco, TX 76702-2683  
Or  
225 South Fifth Street  
Waco, TX 76701

You may contact the Texas Department of Insurance to obtain information on companies, coverages, rights or complaints at

1-800-252-3439

You may write the Texas Department of Insurance at:

Consumer Protection (111-1A)  
P.O. Box 149091  
Austin, TX 78714-9091  
Fax: 512-490-1007

Web: <http://www.tdi.texas.gov>

E-mail: [ConsumerProtection@tdi.texas.gov](mailto:ConsumerProtection@tdi.texas.gov)

### PREMIUM OR CLAIM DISPUTES:

Should you have a dispute concerning your premium or about a claim, you should contact the agent or the company first. If the dispute is not resolved, you may contact the Texas Department of Insurance.

### ATTACH THIS NOTICE TO YOUR POLICY:

This notice is for information only and does not become a part or condition of the attached document.

Para obtener informacion o para someter una queja:

Usted puede llamar al numero de telefono gratis de Insurors Indemnity Company's para informacion o para someter una queja al

1-800-933-7444

Usted tambien puede escribir a Insurors Indemnity Company:

P.O. Box 2683  
Waco, TX 76702-2683  
O  
225 South Fifth Street  
Waco, TX 76701

Puede comunicarse con el Departamento de Seguros de Texas para obtener informacion acerca de companias, coberturas, derechos o quejas al

1-800-252-3439

Puede escribir al Departamento de Seguros de Texas:

Consumer Protection (111-1A)  
P.O. Box 149091  
Austin, TX 78714-9091  
Fax: 512-490-1007

Web: <http://www.tdi.texas.gov>

E-mail: [ConsumerProtection@tdi.texas.gov](mailto:ConsumerProtection@tdi.texas.gov)

### DISPUTAS SOBRE PRIMAS O RECLAMOS:

Si tiene una disputa concemiente a su prima o a un reclamo, debe comunicarse con el agente o la compania primero. Si no se resuelve la disputa, puede entonces comunicarse con el departamento (TDI).

### UNA ESTE AVISO A SU POLIZA:

Este aviso es solo para proposito de informacion y no se convierte en parte o condicion del documento adjunto.

**POWER OF ATTORNEY of INSURORS INDEMNITY COMPANY  
Waco, Texas**

**KNOW ALL PERSONS BY THESE PRESENTS:**

**Number:** CNB-24777-00

That INSURORS INDEMNITY COMPANY, Waco, Texas, organized and existing under the laws of the State of Texas, and authorized and licensed to do business in the State of Texas and the United States of America, does hereby make, constitute and appoint

Omar Villarreal of the City of San Benito, State of TX

as Attorney in Fact, with full power and authority hereby conferred upon him to sign, execute, acknowledge and deliver for and on its behalf as Surety and as its act and deed, all of the following classes of document, to-wit:

Indemnity, Surety and Undertakings that may be desired by contract, or may be given in any action or proceeding in any court of law or equity; Indemnity in all cases where indemnity may be lawfully given and with full power and authority to execute consents and waivers to modify or change or extend any bond or document executed for this Company.

INSURORS INDEMNITY COMPANY

Attest: Tammy Tieperman  
Tammy Tieperman, Secretary

By: Dave E. Talbert  
Dave E. Talbert, President

State of Texas  
County of McLennan

On the 11<sup>th</sup> day of November, 2014, before me a Notary Public in the State of Texas, personally appeared Dave E. Talbert and Tammy Tieperman, who being by me duly sworn, acknowledged that they executed the above Power of Attorney in their capacities as President, and Corporate Secretary, respectively, of Insurors Indemnity Company, and acknowledged said Power of Attorney to be the voluntary act and deed of the Company.

Shelli Carner  
Notary Public, State of Texas



Insurors Indemnity Company certifies that this Power of Attorney is granted under and by authority of the following resolutions of the Company adopted by the Board of Directors on November 11, 2014:

RESOLVED, that all bonds, undertakings, contracts or other obligations may be executed in the name of the Company by persons appointed as Attorney in Fact pursuant to a Power of Attorney issued in accordance with these Resolutions. Said Power of Attorney shall be executed in the name and on behalf of the Company either by the Chairman and CEO or the President, under their respective designation. The signature of such officer and the seal of the Company may be affixed by facsimile to any Power of Attorney, and, unless subsequently revoked and subject to any limitation set forth therein, any such Power of Attorney or certificate bearing such facsimile signature and seal shall be valid and binding upon the Company and any such power so executed and certified by facsimile signature and seal shall be valid and binding upon the Company with respect to any bond or undertaking to which it is validly attached.

RESOLVED, that Attorneys in Fact shall have the power and authority, subject to the terms and limitations of the Power of Attorney issued to them, to execute and deliver on behalf of the Company and to attach the seal of the Company to any and all bonds and undertakings, and any such instrument executed by such Attorneys in Fact shall be binding upon the Company as if signed by an Executive Officer and sealed and attested to by the Secretary or Assistant Secretary of the Company.

I, Tammy Tieperman, Secretary of Insurors Indemnity Company, do hereby certify that the foregoing is a true excerpt from the Resolutions of the said Company as adopted by its Board of Directors on November 11, 2014, and that this Resolution is in full force and effect. I certify that the foregoing Power of Attorney is in full force and effect and has not been revoked.

In Witness Whereof, I have set my hand and the seal of INSURORS INDEMNITY COMPANY on this 12th day of July, 2017.

Tammy Tieperman  
Tammy Tieperman, Secretary

NOTE: IF YOU HAVE ANY QUESTION REGARDING THE VALIDITY OR WORDING OF THIS POWER OF ATTORNEY, PLEASE CALL 800 933 7444 OR WRITE TO US AT P. O. BOX 2683, WACO, TEXAS 76702-2683 OR EMAIL US AT [CONFIRMATION@INSURORS.COM](mailto:CONFIRMATION@INSURORS.COM).

**NON-COLLUSION AFFIDAVIT OF PRIME BIDDER**

State of Texas.....)

County of Hidalgo.....)

Sorais De Hoyos \_\_\_\_\_, being first duly sworn,  
deposes and says that:

(1) He is Managing Member \_\_\_\_\_, of

Five Star Galaxy Construction LLC \_\_\_\_\_, the Bidder that has submitted the attached Bid;

(2) He is fully informed respecting the preparation and contents of this attached bid and of all pertinent circumstances respecting such bid;

(3) Such bid is genuine and is not a collusive or sham Bid;

(4) Neither the said Bidder nor any of its officers, partners, owners, agents, representative:, employees or parties in interest, including this affiant, has in any way colluded, conspired a collusive or sham Bid in connection with the Contract for which the attaché Bid has been submitted or to refrain from bidding in connection with such Contract, or has in any manner, directly or indirectly, sought by agreement or collusion or communication of conference with any other Bidder, firm or person to fix the price or prices in the attached Bid or of any other Bidder, or to fix any overhead, profit or cost element of the Bid price or the Bid price of any other Bidder, or to secure through any collusion, conspiracy, connivance or unlawful agreement any advantage against the Owner or any person interested in the proposed Contract; and

(5) The price or prices quoted in the attached Bid are fair and proper and are not tainted by any collusion, conspiracy, connivance, connivance or unlawful agreement on the part of the Bidder or any of its agents, representatives, owners, employees, or parties in interest, including this affiant.

(Signed) Lencia Ochoa \_\_\_\_\_

Managing Member \_\_\_\_\_

(Title)

Subscribed and sworn to before me on this 11<sup>th</sup> \_\_\_\_\_

Day of July, 2017 \_\_\_\_\_

Krista Nichole Garcia \_\_\_\_\_

Notary Public

Title



**PAYMENT BOND**

(To be used in Texas under V.A.T.S. 5160)

THE STATE OF TEXAS

COUNTY OF Hidalgo

KNOW ALL MEN BY THESE PRESENTS: That we (1) Five Star Galaxy Construction, LLC,  
a (2) Corporation, hereinafter called  
Principal and (3) Insurors Indemnity Company of  
Waco, Texas, hereinafter called the  
Surety, are held and firmly bound unto (4) Hidalgo County of  
Texas, hereinafter called Owner, and unto all persons,  
firms, and corporations who may furnish materials for, or perform labor  
upon the building or improvements hereinafter referred to the penal sum  
of \*\*\*\* (\$ 129,604.70) Dollars in lawful money of the  
United States to be paid in (5) Hidalgo County Texas, for the  
payment of which sum well and truly to be made, we bind ourselves, our  
heirs, executors, administrators, and successors, jointly and severally,  
firmly be these presents.

THE CONDITION OF THIS OBLIGATION is such that whereas, the Principal  
entered into a certain contract with (6) Hidalgo County, the Owner, dated  
the 8TH day of August, A.D. 2017, a copy of which is  
hereto attached and made a part hereof for the construction of:

**HIDALGO COUNTY PRECINCT #3 BORDER ACCESS COLONIA PROJECT  
PALM SUBDIVISION UNIT NO. 2**

---

These footnotes refer to numbers in body of contract above:

Date of Bond must not be prior to date of contract

- (1) Correct name of Contractor
- (2) A Corporation, a Partnership or an Individual, as case may be
- (3) Correct name of Surety
- (4) Correct name of Owner
- (5) County and State
- (6) Owner

NOW, THEREFORE, the condition of this obligation is such that, if the  
-1- Principal shall promptly make payment to all claimants as defined  
in Article 5160 Revised Civil Statutes of Texas, 1925, as amended by  
House Bill 344, Act 56<sup>th</sup> Legislature, Regular Session, 1925 effective  
April 27, 1959, supplying labor and materials in the prosecution of  
the work provided for in said Contract, then this obligation shall be  
null and void, otherwise it shall remain in full force and effect.

This bond is made and entered into solely for the prosecution of all  
claimants supplying labor and material in the prosecution of the work  
provided for in said Contract, and all such claimants shall have a  
direct right of action under the bond as provided in Article 5160,  
Revised Civil Statutes 1925, as amended by House Bill 344, Acts 56<sup>th</sup>  
Legislature, Regular Session, 1959

\*\*\*\* One Hundred Twenty Nine Thousand Six Hundred Four Dollars and Seventy Cents

PROVIDED FURTHER, that if any legal action be filed upon this bond, venue shall lie in Hidalgo County, State of Texas, and that the said surety, for value received hereby stipulates and agrees that no change, extension of time, alteration or addition to the terms of the contract or to the work to be performed thereunder or the specification accompanying the same shall in any way affect its obligation on this bond, and it does hereby waive notice of any such change, extension of time, alteration or addition to the terms of the contract or to the work or to the specifications.

PROVIDED FURTHER, that no final settlement between the Owner and the Contractor shall abridge the right of any beneficiary hereunder, whose claim may be unsatisfied.

IN WITNESS WHEREOF, this instrument is executed in six counterparts, each one of which shall be deemed an original, this the 18TH day of August . A.D., 20 17 .

ATTEST:

Krista Garcia  
(Principal) Secretary

(Seal)

Krista Garcia  
Witness as to Principal

4012 S. Cesar Chavez Rd. San Juan, TX 78589  
(Address)

Principal Five Star Galaxy Construction, LLC.  
By José Ochoa

(Address) 4012 S. Cesar Chavez Rd., San Juan, TX 78589

Telephone Number: 1954 212-8226

Insurors Indemnity Company  
Surety

ATTEST:

Sherri Garcia  
(Surety) Secretary

(Seal)

Sherri Garcia  
Witness as to Surety

148 N. Sam Houston Blvd. San Benito, TX 78586  
(Address)

By [Signature]  
[Signature]

(Address) P. O. Box 2683

Waco, TX 76702-2683

NOTE: If Contractor is partnership all Partners should execute bond

Telephone Number: (800) 933-7444

PAYMENT BOND FORM

\_\_\_\_\_  
(Address)  
Telephone Number: \_\_\_\_\_

\_\_\_\_\_  
(Individual Principal)  
\_\_\_\_\_  
(Business Address)  
Telephone Number: \_\_\_\_\_

\_\_\_\_\_  
(Corporate Principal)

\_\_\_\_\_  
(Business Address) (Affix Corporate SEAL)  
Telephone Number: \_\_\_\_\_  
BY \_\_\_\_\_

\_\_\_\_\_  
ATTEST:

\_\_\_\_\_  
(Business Address) (Affix Corporate SEAL)  
BY \_\_\_\_\_  
Telephone Number: \_\_\_\_\_

CERTIFICATES AS TO CORPORATE PRINCIPAL

I, Kristen Garcia, certify that I am the Secretary Secretary of the corporation named as Principal in the within bond; that \_\_\_\_\_ who signed the said bond on behalf of the Principal was then Sorais Dettyes of said corporation; and I know his signature, and his signature thereto is genuine; and that said bond was duly signed, sealed, and attested for and in behalf of said corporation by authority of its governing body.

Kristen Garcia  
(TITLE) Secretary  
DATE 8-18-17

\_\_\_\_\_  
(AFFIX CORPORATE SEAL)

Telephone Number (957) 266-8419

The rate of premium on this bond is \$30 per thousand. Total amount of premium charge \$ 3,888.00.  
(The above must be filled in by corporate surety.) (Power-of-Attorney of person signing for surety company must be attached.)

**PERFORMANCE BOND**

(To be used in Texas under V.A.T.S. 5160)

THE STATE OF TEXAS

COUNTY OF Hidalgo

KNOW ALL MEN BY THESE PRESENTS: That we (1) Five Star Galaxy Construction, LLC., a (2) Corporation OF San Juan Texas hereinafter called Principal and (3) INSURORS INDEMNITY COMPANY of Waco, State of Texas, hereinafter called the Surety, are held and firmly bound unto (4) Hidalgo County of Texas, hereinafter called Owner, in the penal sum of \*\*\*\* (\$ 129,604.70) Dollars in lawful money of the United States to be paid in (5) Hidalgo County Texas, for the payment of which sum well and truly to be made, we bind ourselves, our heirs, executors, administrators, and successors, jointly and severally, firmly be these presents.

THE CONDITION OF THIS OBLIGATION is such that whereas, the Principal entered into a certain contract with (6) Hidalgo County, the Owner, dated the 8TH day of August, A.D. 20 17, a copy of which is hereto attached and made a part hereof for the construction of:

**HIDALGO COUNTY PRECINCT #3 BORDER ACCESS COLONIA PROJECT  
PALM SUBDIVISION UNIT NO. 2**

hereinafter called the "Work").

---

These footnotes refer to the numbers in body of contract above:

Date of Bond must not be prior to date of contract

- (1) Correct name of Contractor
- (2) A Corporation, a Partnership or an Individual, as case may be
- (3) Correct name of Surety
- (4) Correct name of Owner
- (5) County and State
- (6) Owner

(Texas Performance Bond) - Page 2.

NOW, THEREFORE, if the Principal shall well, truly and faithfully perform the work in accordance with the plans, specifications, and contract documents during the original term thereof, and any extensions thereof which may be granted by the Owner, with or without notice to the Surety, and if he shall satisfy all claims and demands incurred under such contract, and shall fully indemnify and save harmless the Owner from all costs and damages which it may suffer by reason of failure to do so, and shall reimburse and repay the Owner all outlay and expense which the Owner may incur in making good any default, then this obligation shall be void; otherwise to remain in full force and effect.

PROVIDED FURTHER, that if any legal action be filed upon this bond, venue shall lie in Hidalgo County, State of Texas, and that the said surety, for value received hereby stipulates and agrees that no change, extension of time, alteration or addition to the terms of the contract or to the work to be performed thereunder or the specifications accompanying the

\*\*\*\* One Hundred Twenty Nine Thousand Six Hundred Four dollars and Seventy Cents

same shall in any way affect its obligation on this bond, and it does hereby waive notice of any such change, extension of time, alternation or addition to the terms of the contract or to the work or to the specifications.

IN WITNESS WHEREOF, this instrument is executed in six counterparts, each one of which shall be deemed an original, this the 18TH day of August 2017. A.D.

ATTEST:

Krista Garcia  
(Principal) Secretary

(Seal)

Krista Garcia  
Witness as to Principal

4012 S, Cesar Chavez Rd. San Juan, TX 78589  
(Address)

Principal Five Star Galaxy Construction, LLC.  
By [Signature]

(Address) 4012 S, Cesar Chavez Rd. San Juan, TX 78589

Telephone Number: (956) 212-8226

ATTEST:

Sherri Garcia  
(Surety) Secretary

(Seal)

Sherri Garcia  
Witness as to Surety

148 N Sam Houston Blvd. San Benito, TX 78586  
(Address)

Surety: Insurers Indemnity Company

By [Signature]

(Address) P. O. Box 2683 Waco, TX 76702-2683

Telephone Number: (800) 933-7444

NOTE: If Contractor is a partnership, all partners should execute bond.

PERFORMANCE-PAYMENT BOND FORM

\_\_\_\_\_  
(Address)  
Telephone Number: \_\_\_\_\_

\_\_\_\_\_  
(Individual Principal)  
\_\_\_\_\_  
(Business Address)  
Telephone Number: \_\_\_\_\_

\_\_\_\_\_  
(Corporate Principal)

\_\_\_\_\_  
(Business Address) (Affix Corporate SEAL)  
Telephone Number: \_\_\_\_\_  
BY \_\_\_\_\_

\_\_\_\_\_  
ATTEST:

\_\_\_\_\_  
(Business Address) (Affix Corporate SEAL)  
BY \_\_\_\_\_  
Telephone Number: \_\_\_\_\_

CERTIFICATES AS TO CORPORATE PRINCIPAL

I, Krista Gania, certify that I am the Secretary  
Secretary of the corporation named as Principal in the within bond; that  
Sorris De Hoyus, who signed the said bond on behalf of the  
Principal was then Sorris De Hoyus of said corporation; and I  
know his signature, and his signature thereto is genuine; and that said  
bond was duly signed, sealed, and attested for and in behalf of said  
corporation by authority of its governing body.

D. G. Gania  
(TITLE) secretary  
DATE 8-18-17

\_\_\_\_\_  
(AFFIX CORPORATE SEAL)

Telephone Number: (956) 526-8419

The rate of premium on this bond is \$30 per thousand. Total  
amount of premium charge \$ 3,888.00  
(The above must be filled in by corporate surety.) (Power-of-Attorney of  
person signing for surety company must be attached.)

**POWER OF ATTORNEY of INSURORS INDEMNITY COMPANY  
Waco, Texas**

**KNOW ALL PERSONS BY THESE PRESENTS:**

**Number:** CNB-24777-00

That INSURORS INDEMNITY COMPANY, Waco, Texas, organized and existing under the laws of the State of Texas, and authorized and licensed to do business in the State of Texas and the United States of America, does hereby make, constitute and appoint

Omar Villarreal of the City of San Benito, State of TX

as Attorney in Fact, with full power and authority hereby conferred upon him to sign, execute, acknowledge and deliver for and on its behalf as Surety and as its act and deed, all of the following classes of document, to-wit:

Indemnity, Surety and Undertakings that may be desired by contract, or may be given in any action or proceeding in any court of law or equity; Indemnity in all cases where indemnity may be lawfully given and with full power and authority to execute consents and waivers to modify or change or extend any bond or document executed for this Company.

INSURORS INDEMNITY COMPANY

Attest: Tammy Tieperman  
Tammy Tieperman, Secretary

By: Dave E. Talbert  
Dave E. Talbert, President

State of Texas  
County of McLennan

On the 11<sup>th</sup> day of November, 2014, before me a Notary Public in the State of Texas, personally appeared Dave E. Talbert and Tammy Tieperman, who being by me duly sworn, acknowledged that they executed the above Power of Attorney in their capacities as President, and Corporate Secretary, respectively, of Insurors Indemnity Company, and acknowledged said Power of Attorney to be the voluntary act and deed of the Company.

Sherri Carnes  
Notary Public, State of Texas



Insurors Indemnity Company certifies that this Power of Attorney is granted under and by authority of the following resolutions of the Company adopted by the Board of Directors on November 11, 2014:

RESOLVED, that all bonds, undertakings, contracts or other obligations may be executed in the name of the Company by persons appointed as Attorney in Fact pursuant to a Power of Attorney issued in accordance with these Resolutions. Said Power of Attorney shall be executed in the name and on behalf of the Company either by the Chairman and CEO or the President, under their respective designation. The signature of such officer and the seal of the Company may be affixed by facsimile to any Power of Attorney, and, unless subsequently revoked and subject to any limitation set forth therein, any such Power of Attorney or certificate bearing such facsimile signature and seal shall be valid and binding upon the Company and any such power so executed and certified by facsimile signature and seal shall be valid and binding upon the Company with respect to any bond or undertaking to which it is validly attached.

RESOLVED, that Attorneys in Fact shall have the power and authority, subject to the terms and limitations of the Power of Attorney issued to them, to execute and deliver on behalf of the Company and to attach the seal of the Company to any and all bonds and undertakings, and any such instrument executed by such Attorneys in Fact shall be binding upon the Company as if signed by an Executive Officer and sealed and attested to by the Secretary or Assistant Secretary of the Company.

I, Tammy Tieperman, Secretary of Insurors Indemnity Company, do hereby certify that the foregoing is a true excerpt from the Resolutions of the said Company as adopted by its Board of Directors on November 11, 2014, and that this Resolution is in full force and effect. I certify that the foregoing Power of Attorney is in full force and effect and has not been revoked.

In Witness Whereof, I have set my hand and the seal of INSURORS INDEMNITY COMPANY on this 18th day of August, 2017

Tammy Tieperman  
Tammy Tieperman, Secretary

NOTE: IF YOU HAVE ANY QUESTION REGARDING THE VALIDITY OR WORDING OF THIS POWER OF ATTORNEY, PLEASE CALL 800 933 7444 OR WRITE TO US AT P. O. BOX 2683, WACO, TEXAS 76702-2683 OR EMAIL US AT CONFIRMATION@INSURORS.COM.



P&C 877 282 1625  
Bonds 800 933 7444

225 South Fifth Street  
PO Box 2683  
Waco, Texas 76702-2683

## IMPORTANT NOTICE - AVISO IMPORTANTE

To obtain information or make a complaint:

You may call Insurors Indemnity Company's toll-free telephone number for information or to make a complaint at:

1-800-933-7444

You may also write to Insurors Indemnity Company at:

P.O. Box 2683  
Waco, TX 76702-2683  
Or  
225 South Fifth Street  
Waco, TX 76701

You may contact the Texas Department of Insurance to obtain information on companies, coverages, rights or complaints at

1-800-252-3439

You may write the Texas Department of Insurance at:

Consumer Protection (111-1A)  
P.O. Box 149091  
Austin, TX 78714-9091  
Fax: 512-490-1007

Web: <http://www.tdi.texas.gov>

E-mail: [ConsumerProtection@tdi.texas.gov](mailto:ConsumerProtection@tdi.texas.gov)

### PREMIUM OR CLAIM DISPUTES:

Should you have a dispute concerning your premium or about a claim, you should contact the agent or the company first. If the dispute is not resolved, you may contact the Texas Department of Insurance.

### ATTACH THIS NOTICE TO YOUR POLICY:

This notice is for information only and does not become a part or condition of the attached document.

Para obtener informacion o para someter una queja:

Usted puede llamar al numero de telefono gratis de Insurors Indemnity Company's para informacion o para someter una queja al

1-800-933-7444

Usted tambien puede escribir a Insurors Indemnity Company:

P.O. Box 2683  
Waco, TX 76702-2683  
O  
225 South Fifth Street  
Waco, TX 76701

Puede comunicarse con el Departamento de Seguros de Texas para obtener informacion acerca de companias, coberturas, derechos o quejas al

1-800-252-3439

Puede escribir al Departamento de Seguros de Texas:

Consumer Protection (111-1A)  
P.O. Box 149091  
Austin, TX 78714-9091  
Fax: 512-490-1007

Web: <http://www.tdi.texas.gov>

E-mail: [ConsumerProtection@tdi.texas.gov](mailto:ConsumerProtection@tdi.texas.gov)

### DISPUTAS SOBRE PRIMAS O RECLAMOS:

Si tiene una disputa concemiente a su prima o a un reclamo, debe comunicarse con el agente o la compania primero. Si no se resuelve la disputa, puede entonces comunicarse con el departamento (TDI).

### UNA ESTE AVISO A SU POLIZA:

Este aviso es solo para proposito de informacion y no se convierte en parte o condicion del documento adjunto.

THE STATE OF TEXAS §  
  §  
COUNTY OF HIDALGO §

FILED
AT <u>12:00</u> O'CLOCK <u>P</u> M
SEP 26 2017
ARTURO GUAJARDO, JR. COUNTY CLERK HIDALGO COUNTY, TEXAS
BY: <u>NEC</u> DEPUTY

**CONSTRUCTION CONTRACT  
C-CAP-17-186-08-08**

This Agreement, entered into this **8th** day of **August, 2017** by and between Hidalgo County (hereinafter called the "OWNER," and, **FIVE STAR GALAXY CONSTRUCTION, LLC** (a Texas corporation), of County of Hidalgo, and State of Texas, hereinafter called "CONTRACTOR".

**WITNESSETH**

That for and in consideration of the payments and agreement hereinafter mentioned, to be made and performed by the OWNER, the CONTRACTOR hereby agrees with the OWNER to commence and complete the construction described as follows:

**PALM SUBDIVISION UNIT NO. 2**

Hereinafter called the project, for the sum of **One Hundred Twenty Nine Thousand Six Hundred Four Dollars and seventy Cents (\$129,604.70)** and all extra work in connection therewith, under the terms and stated in the General and Special Conditions of the Contract; and at his (its or their) own proper cost and expense to furnish all the materials, supplies, machinery, equipment, tools, superintendence, labor, insurance, and other accessories and services necessary to complete the said project in accordance with the conditions and prices stated in the Proposal, the General Conditions and Special Conditions printed or written explanatory matter thereof, the specifications and contract documents therefore as prepared by **Javier Hinojosa Engineering**, entitled the Architect/Engineer, and as enumerated in Paragraph 1.01.A.12 of the General Conditions, all of which are made a part hereof and collectively evidence and constitute the contract.

The CONTRACTOR hereby agrees to commence work under this contract on or after a date to be specified in written "Notice to Proceed" of the OWNER and to fully complete the project within **120 consecutive calendar days thereafter**. The CONTRACTOR further agrees to pay, as liquidated damages, the sum of **\$\_250.00** for each consecutive calendar day thereafter.

The OWNER agrees to pay the CONTRACTOR in current funds for the performance of the contract, subject to additions and deductions, as provided in the General Conditions of the contract, and to make payments on account thereof as provided in Paragraphs 14.02.C and 14.07.C of the General Conditions.



**HIDALGO COUNTY**  
(Including all funding sources, programs, and entities)  
**REQUEST FOR BIDS**  
Project Name

RFB No.: CAP-17-186-07-12-YSS

**RFB SUBMITTAL CHECK LIST**

All forms listed below must be included in the RFB response.

Indicate with a check mark (✓) the Forms completed and included in this response:

- Page 8 of Legal Notice
- Exhibit "B" Bid Page
- Exhibit "C" – Insurance Acknowledgement Forms
- Exhibit "D" -CIQ Form -Copy of County Clerk File Recording fee receipt (if applicable).
- Exhibit "E" Vendor Bidder Applications and IRS form W-9
- Exhibit "F" Certification Regarding Debarment
- SAMS.gov Registration Acknowledgement [www.sam.gov](http://www.sam.gov)
- Bid Bond
- One (1) Original, Three (3) Copies of Bid(s) (see number 2 of Legal Notice).

## **EXHIBIT "C"**

### **Insurance Requirements**

The Bidder awarded the contract shall furnish proof of insurance, which will also include any subcontractor that is subcontracted by the bidder in at least the following limits, to be in place prior to providing any services under this Contract and to continue at all times in force in effect during the term of this Contract:

1. A Five Hundred Thousand Dollar (\$500,000.00) Comprehensive General Liability insurance policy providing additional coverage to all underlying liabilities of County.
2. Automobile liability insurance policy with limits of at least Three Hundred Thousand Dollars (\$300,000.00) per person and Five Hundred Thousand Dollars (\$500,000.00) per occurrence. Coverage should include injury to or death of persons and property damage claims with limits up to Five Hundred Thousand (\$500,000.00) arising out of the services provided to County hereunder.
3. Uninsured/Underinsured motorist coverage in an amount equal to the bodily injury limits set forth immediately above;
4. Workers compensation insurance in amounts established by Texas law, unless the Bidder is specifically exempted from the Texas Workers Compensation Act, Texas Labor Code Chapter 401, et. seq.

Certificates of insurance naming County as an additional insured shall be submitted to County for approval prior to any services being performed by Contractor. Each policy of insurance required hereunder shall extend for a period equivalent to, or longer than the term of the Contract, and any insurer hereunder shall be required to give at least thirty (30) days written notice to the County prior to the cancellation of any such coverage on the termination date, or otherwise. This Contract shall be automatically suspended upon the cancellation, or other termination, of any required policy of insurance hereunder, and such suspension shall continue until evidence adequate replacement coverage is provided to County. If replacement coverage is not provided within thirty (30) days following suspension of the Contract, this Contract shall automatically terminate.

# Insurance Requirement Acknowledgment

I, Sorais De Hoyos, authorized representative for Five Star Galaxy Construction LLC  
Company/Vendor

hereby acknowledge receipt of the County's required insurance limits. Said requirements:

- will be acquired within 10 working days after notification from Purchasing Department of bid awarded by the Hidalgo County Commissioners= Court;
- will acquire additional amounts required to meet the County's requirements within 10 working days after notification from Purchasing Department of bid award by the Hidalgo County Commissioners= Court; currently carry the following:

Automobile Liability: \$ 500,000.00 General Liability: \$ 2,000,000.00

- have already been met, see attached copy of insurance certificate.

Sorais De Hoyos  
Authorized Representative

07/11/2017  
Date

## **Notice to Bidder:**

A certificate of insurance for the required insurance limits shall be provided to the Purchasing Department's Contract Managers in order to qualify for award of bid and to execute a contract between your Company and the County

Failure to provide Certificates of Insurance to the Purchasing Department's Contract Managers will cause the bid award to be rescinded and re-awarded to next lowest bidder. Certificates of Insurance will be monitored and verified on a **quarterly basis** to ensure coverage policy is in place. It is the Company's obligation to maintain the appropriate insurance coverage throughout the term of the contract.

**THIS FORM MUST ACCOMPANY BID PACKET**

## PROJECT REQUIREMENTS ACKNOWLEDGMENT

This is to certify that I, Sorais De Hoyos, possess all of the APPLICABLE:

1. Licenses: None
2. Bonds: Yes
3. Certificates: None
4. Permits: None
5. Other: None

necessary to carry out the required project. Furthermore, I am providing copies of the required documentation so that, if my company is awarded this bid, I may be eligible to enter into a contract with Hidalgo County and proceed to complete the project in a timely manner.

\* Any licenses, bonds, certificates, permits, etc. which are required must be presented as part of the bid packet in order to expedite the bid evaluation process. Failure to provide said documentation will result in the disqualification of your bid.

  
Authorized Signature

07/11/2017  
Date

Five Star Galaxy Construction LLC  
Company

4012 S Cesar Chavez Rd  
Address

San Juan, TX 78589  
City, State, Zip



# CERTIFICATE OF LIABILITY INSURANCE

DATE (MM/DD/YYYY)

08/10/17

THIS CERTIFICATE IS ISSUED AS A MATTER OF INFORMATION ONLY AND CONFERS NO RIGHTS UPON THE CERTIFICATE HOLDER. THIS CERTIFICATE DOES NOT AFFIRMATIVELY OR NEGATIVELY AMEND, EXTEND OR ALTER THE COVERAGE AFFORDED BY THE POLICIES BELOW. THIS CERTIFICATE OF INSURANCE DOES NOT CONSTITUTE A CONTRACT BETWEEN THE ISSUING INSURER(S), AUTHORIZED REPRESENTATIVE OR PRODUCER, AND THE CERTIFICATE HOLDER.

**IMPORTANT:** If the certificate holder is an **ADDITIONAL INSURED**, the policy(ies) must have **ADDITIONAL INSURED** provisions or be endorsed. If **SUBROGATION IS WAIVED**, subject to the terms and conditions of the policy, certain policies may require an endorsement. A statement on this certificate does not confer rights to the certificate holder in lieu of such endorsement(s).

<b>PRODUCER</b> SALAZAR INSURANCE AGENCY 6421 N 10th, Ste 160 Mc Allen, TX 78504	<b>CONTACT NAME:</b> HERLINDA D SALAZAR <b>PHONE (A/C, No, Ext):</b> (956)631-0004 <b>E-MAIL ADDRESS:</b> linda@salazarinsuranceagency.com	<b>FAX (A/C, No):</b> (956)630-3209
	<b>INSURER(S) AFFORDING COVERAGE</b>	
<b>INSURED</b> FIVE STAR GALAXY CONSTRUCTION 4012 SOUTH CESAR CHAVEZ RD SAN JUAN, TEXAS 78589	<b>INSURER A :</b> TEXAS MUTUAL INSURANCE COMPANY	
	<b>INSURER B :</b>	
	<b>INSURER C :</b>	
	<b>INSURER D :</b>	
	<b>INSURER E :</b>	
	<b>INSURER F :</b>	

**COVERAGES****CERTIFICATE NUMBER:****REVISION NUMBER:**

THIS IS TO CERTIFY THAT THE POLICIES OF INSURANCE LISTED BELOW HAVE BEEN ISSUED TO THE INSURED NAMED ABOVE FOR THE POLICY PERIOD INDICATED. NOTWITHSTANDING ANY REQUIREMENT, TERM OR CONDITION OF ANY CONTRACT OR OTHER DOCUMENT WITH RESPECT TO WHICH THIS CERTIFICATE MAY BE ISSUED OR MAY PERTAIN, THE INSURANCE AFFORDED BY THE POLICIES DESCRIBED HEREIN IS SUBJECT TO ALL THE TERMS, EXCLUSIONS AND CONDITIONS OF SUCH POLICIES. LIMITS SHOWN MAY HAVE BEEN REDUCED BY PAID CLAIMS.

INSR LTR	TYPE OF INSURANCE	ADDL SUBR INSD WVD	POLICY NUMBER	POLICY EFF (MM/DD/YYYY)	POLICY EXP (MM/DD/YYYY)	LIMITS
	<b>COMMERCIAL GENERAL LIABILITY</b> <input type="checkbox"/> CLAIMS-MADE <input type="checkbox"/> OCCUR GEN'L AGGREGATE LIMIT APPLIES PER: <input type="checkbox"/> POLICY <input type="checkbox"/> PRO-JECT <input type="checkbox"/> LOC OTHER:					EACH OCCURRENCE \$ DAMAGE TO RENTED PREMISES (Ea occurrence) \$ MED EXP (Any one person) \$ PERSONAL & ADV INJURY \$ GENERAL AGGREGATE \$ PRODUCTS - COMP/OP AGG \$
	<b>AUTOMOBILE LIABILITY</b> <input type="checkbox"/> ANY AUTO <input type="checkbox"/> OWNED AUTOS ONLY <input type="checkbox"/> HIRED AUTOS ONLY <input type="checkbox"/> SCHEDULED AUTOS <input type="checkbox"/> NON-OWNED AUTOS ONLY					COMBINED SINGLE LIMIT (Ea accident) \$ BODILY INJURY (Per person) \$ BODILY INJURY (Per accident) \$ PROPERTY DAMAGE (Per accident) \$
	<b>UMBRELLA LIAB</b> <input type="checkbox"/> OCCUR <b>EXCESS LIAB</b> <input type="checkbox"/> CLAIMS-MADE DED RETENTION \$					EACH OCCURRENCE \$ AGGREGATE \$
A	<b>WORKERS COMPENSATION AND EMPLOYERS' LIABILITY</b> <input type="checkbox"/> ANY PROPRIETOR/PARTNER/EXECUTIVE OFFICER/MEMBER EXCLUDED? (Mandatory in NH) If yes, describe under DESCRIPTION OF OPERATIONS below	Y/N <input type="checkbox"/> N/A	0001325484	05/19/17	05/19/18	<input checked="" type="checkbox"/> PER STATUTE <input type="checkbox"/> OTH-ER E.L. EACH ACCIDENT \$ 100,000 E.L. DISEASE - EA EMPLOYEE \$ 100,000 E.L. DISEASE - POLICY LIMIT \$ 500,000

DESCRIPTION OF OPERATIONS / LOCATIONS / VEHICLES (ACORD 101, Additional Remarks Schedule, may be attached if more space is required)

CONTRACT NO. C-CAP-17-186-08-08

**CERTIFICATE HOLDER****CANCELLATION**
 HIDALGO COUNTY  
 2812 S. HIGHWAY BUS. 281  
 EDINBURG TEXAS 78539

SHOULD ANY OF THE ABOVE DESCRIBED POLICIES BE CANCELLED BEFORE THE EXPIRATION DATE THEREOF, NOTICE WILL BE DELIVERED IN ACCORDANCE WITH THE POLICY PROVISIONS.

AUTHORIZED REPRESENTATIVE



# CERTIFICATE OF LIABILITY INSURANCE

DATE (MM/DD/YYYY)  
08/17/2017

THIS CERTIFICATE IS ISSUED AS A MATTER OF INFORMATION ONLY AND CONFERS NO RIGHTS UPON THE CERTIFICATE HOLDER. THIS CERTIFICATE DOES NOT AFFIRMATIVELY OR NEGATIVELY AMEND, EXTEND OR ALTER THE COVERAGE AFFORDED BY THE POLICIES BELOW. THIS CERTIFICATE OF INSURANCE DOES NOT CONSTITUTE A CONTRACT BETWEEN THE ISSUING INSURER(S), AUTHORIZED REPRESENTATIVE OR PRODUCER, AND THE CERTIFICATE HOLDER.

IMPORTANT: If the certificate holder is an ADDITIONAL INSURED, the policy(ies) must have ADDITIONAL INSURED provisions or be endorsed. If SUBROGATION IS WAIVED, subject to the terms and conditions of the policy, certain policies may require an endorsement. A statement on this certificate does not confer rights to the certificate holder in lieu of such endorsement(s).

<b>PRODUCER</b> Statewide Commercial Ins Brokers 2406 N Lake Avenue Altadena, CA 91001 Phone (877) 207-7900 Fax (626) 340-4807	<b>CONTACT NAME:</b> Customer Service <b>PHONE (A/C No, Ext):</b> (877) 207-7900 <b>E-MAIL ADDRESS:</b> mail@st8wide.com <b>FAX (A/C, No):</b> (626) 340-4807													
	<table border="1"> <tr> <th>INSURER(S) AFFORDING COVERAGE</th> <th>NAIC #</th> </tr> <tr> <td>INSURER A : Rockingham Casualty Company</td> <td></td> </tr> <tr> <td>INSURER B : Infinity County Mutual Insurance Company</td> <td></td> </tr> <tr> <td>INSURER C :</td> <td></td> </tr> <tr> <td>INSURER D :</td> <td></td> </tr> <tr> <td>INSURER E :</td> <td></td> </tr> <tr> <td>INSURER F :</td> <td></td> </tr> </table>	INSURER(S) AFFORDING COVERAGE	NAIC #	INSURER A : Rockingham Casualty Company		INSURER B : Infinity County Mutual Insurance Company		INSURER C :		INSURER D :		INSURER E :		INSURER F :
INSURER(S) AFFORDING COVERAGE	NAIC #													
INSURER A : Rockingham Casualty Company														
INSURER B : Infinity County Mutual Insurance Company														
INSURER C :														
INSURER D :														
INSURER E :														
INSURER F :														
<b>INSURED</b> Five Star Galaxy 4012 S. Cesar Chavez Rd. San Juan TX 78589														

**COVERAGES**      **CERTIFICATE NUMBER:**      **REVISION NUMBER:**

THIS IS TO CERTIFY THAT THE POLICIES OF INSURANCE LISTED BELOW HAVE BEEN ISSUED TO THE INSURED NAMED ABOVE FOR THE POLICY PERIOD INDICATED. NOTWITHSTANDING ANY REQUIREMENT, TERM OR CONDITION OF ANY CONTRACT OR OTHER DOCUMENT WITH RESPECT TO WHICH THIS CERTIFICATE MAY BE ISSUED OR MAY PERTAIN, THE INSURANCE AFFORDED BY THE POLICIES DESCRIBED HEREIN IS SUBJECT TO ALL THE TERMS, EXCLUSIONS AND CONDITIONS OF SUCH POLICIES. LIMITS SHOWN MAY HAVE BEEN REDUCED BY PAID CLAIMS.

INSR LTR	TYPE OF INSURANCE	ADDL BR INSR	WVD	POLICY NUMBER	POLICY EFF (MM/DD/YYYY)	POLICY EXP (MM/DD/YYYY)	LIMITS
A	<input checked="" type="checkbox"/> COMMERCIAL GENERAL LIABILITY <input type="checkbox"/> CLAIMS-MADE <input checked="" type="checkbox"/> OCCUR GEN'L AGGREGATE LIMIT APPLIES PER: <input checked="" type="checkbox"/> POLICY <input type="checkbox"/> PROJECT <input type="checkbox"/> LOC <input type="checkbox"/> OTHER			RTXA500475	07/18/2017	07/18/2018	EACH OCCURRENCE \$ 1,000,000 DAMAGE TO RENTED PREMISES (Ea occurrence) \$ 50,000 MED EXP (Any one person) \$ 5,000 PERSONAL & ADV INJURY \$ 1,000,000 GENERAL AGGREGATE \$ 2,000,000 PRODUCTS - COMP/OP AGG \$ 2,000,000 \$
B	<b>AUTOMOBILE LIABILITY</b> <input type="checkbox"/> ANY AUTO OWNED AUTOS ONLY <input type="checkbox"/> HIRED AUTOS ONLY <input checked="" type="checkbox"/> SCHEDULED AUTOS <input type="checkbox"/> NON-OWNED AUTOS ONLY			542-86002-1195-001	04/07/2017	04/07/2018	COMBINED SINGLE LIMIT (Ea accident) \$ 1,000,000 BODILY INJURY (Per person) \$ BODILY INJURY (Per accident) \$ PROPERTY DAMAGE (Per accident) \$ \$
	<input type="checkbox"/> UMBRELLA LIAB <input type="checkbox"/> OCCUR <input type="checkbox"/> EXCESS LIAB <input type="checkbox"/> CLAIMS-MADE <input type="checkbox"/> DED <input type="checkbox"/> RETENTION \$						EACH OCCURRENCE \$ AGGREGATE \$ \$
	<b>WORKERS COMPENSATION AND EMPLOYERS' LIABILITY</b> ANY PROPRIETOR/PARTNER/EXECUTIVE OFFICER/MEMBER EXCLUDED? (Mandatory in NH) If yes, describe under DESCRIPTION OF OPERATIONS below		Y/N	N/A			<input type="checkbox"/> PER STATUTE <input type="checkbox"/> OTHER E.L. EACH ACCIDENT \$ E.L. DISEASE - EA EMPLOYEE \$ E.L. DISEASE - POLICY LIMIT \$

DESCRIPTION OF OPERATIONS / LOCATIONS / VEHICLES (Attach ACORD 101, Additional Remarks Schedule, if more space is required)

Contract No. C-CAP-17-186-08-08

<b>CERTIFICATE HOLDER</b> Hidalgo County 2812 S Highway Bus. 281 Edinburg, Texas 78539	<b>CANCELLATION</b> SHOULD ANY OF THE ABOVE DESCRIBED POLICIES BE CANCELLED BEFORE THE EXPIRATION DATE THEREOF, NOTICE WILL BE DELIVERED IN ACCORDANCE WITH THE POLICY PROVISIONS. AUTHORIZED REPRESENTATIVE
---	--



# CERTIFICATE OF LIABILITY INSURANCE

DATE (MM/DD/YYYY)  
08/31/2017

**THIS CERTIFICATE IS ISSUED AS A MATTER OF INFORMATION ONLY AND CONFERS NO RIGHTS UPON THE CERTIFICATE HOLDER. THIS CERTIFICATE DOES NOT AFFIRMATIVELY OR NEGATIVELY AMEND, EXTEND OR ALTER THE COVERAGE AFFORDED BY THE POLICIES BELOW. THIS CERTIFICATE OF INSURANCE DOES NOT CONSTITUTE A CONTRACT BETWEEN THE ISSUING INSURER(S), AUTHORIZED REPRESENTATIVE OR PRODUCER, AND THE CERTIFICATE HOLDER.**

**IMPORTANT: If the certificate holder is an ADDITIONAL INSURED, the policy(ies) must be endorsed. If SUBROGATION IS WAIVED, subject to the terms and conditions of the policy, certain policies may require an endorsement. A statement on this certificate does not confer rights to the certificate holder in lieu of such endorsement(s).**

<b>PRODUCER</b> Statewide Commercial Insurance Brok 2406 N Lake Avenue Altadena, CA 91001 Phone (877) 207-7900 Fax (626) 340-4807		<b>CONTACT NAME:</b> Customer Service Department <b>PHONE (A/C, No, Ext):</b> (877) 207-7900 <b>E-MAIL ADDRESS:</b> mail@st8wide.com	<b>FAX (A/C, No):</b> (626) 744-9196
<b>INSURED</b> Five Star Galaxy 4012 S. Cesar Chavez Rd. San Juan TX 78589		<b>INSURER(S) AFFORDING COVERAGE</b>	
		<b>INSURER A:</b> Rockingham Casualty Company	<b>NAIC #</b>
		<b>INSURER B:</b> Infinity County Mutual Insurance Company	
		<b>INSURER C:</b> Commerce & Industry Ins Co	
		<b>INSURER D:</b>	
		<b>INSURER E:</b>	
		<b>INSURER F:</b>	

**COVERAGES**      **CERTIFICATE NUMBER: 1**      **REVISION NUMBER:**

THIS IS TO CERTIFY THAT THE POLICIES OF INSURANCE LISTED BELOW HAVE BEEN ISSUED TO THE INSURED NAMED ABOVE FOR THE POLICY PERIOD INDICATED. NOTWITHSTANDING ANY REQUIREMENT, TERM OR CONDITION OF ANY CONTRACT OR OTHER DOCUMENT WITH RESPECT TO WHICH THIS CERTIFICATE MAY BE ISSUED OR MAY PERTAIN, THE INSURANCE AFFORDED BY THE POLICIES DESCRIBED HEREIN IS SUBJECT TO ALL THE TERMS, EXCLUSIONS AND CONDITIONS OF SUCH POLICIES. LIMITS SHOWN MAY HAVE BEEN REDUCED BY PAID CLAIMS.

INSR LTR	TYPE OF INSURANCE	ADDSUBR INSR_WVD	POLICY NUMBER	POLICY EFF (MM/DD/YYYY)	POLICY EXP (MM/DD/YYYY)	LIMITS
A	<input checked="" type="checkbox"/> COMMERCIAL GENERAL LIABILITY <input type="checkbox"/> CLAIMS-MADE <input checked="" type="checkbox"/> OCCUR	Y Y	RTXA500475	07/18/2017	07/18/2018	EACH OCCURRENCE \$ 1,000,000.00
	<input type="checkbox"/>					DAMAGE TO RENTED PREMISES (Ea occurrence) \$ 50,000.00
	<input type="checkbox"/>					MED EXP (Any one person) \$ 5,000.00
	<input type="checkbox"/>					PERSONAL & ADV INJURY \$ 1,000,000.00
GEN'L AGGREGATE LIMIT APPLIES PER:						GENERAL AGGREGATE \$ 2,000,000.00
<input checked="" type="checkbox"/> POLICY <input type="checkbox"/> PROJECT <input type="checkbox"/> LOC						PRODUCTS - COMP/OP AGG \$ 2,000,000.00
<input type="checkbox"/> OTHER						\$
B	<b>AUTOMOBILE LIABILITY</b> <input type="checkbox"/> ANY AUTO <input type="checkbox"/> ALL OWNED AUTOS <input checked="" type="checkbox"/> HIRED AUTOS	Y Y	542-86002-1195-001	04/07/2017	04/07/2018	COMBINED SINGLE LIMIT (Ea accident) \$ 1,000,000.00
	<input checked="" type="checkbox"/> SCHEDULED AUTOS <input checked="" type="checkbox"/> NON-OWNED AUTOS					BODILY INJURY (Per person) \$
	<input type="checkbox"/>					BODILY INJURY (Per accident) \$
	<input type="checkbox"/>					PROPERTY DAMAGE (Per accident) \$
C	<input type="checkbox"/> UMBRELLA LIAB <input checked="" type="checkbox"/> EXCESS LIAB	Y Y	EBU 023511293	08/28/2017	08/28/2018	EACH OCCURRENCE \$ 1,000,000.00
	<input type="checkbox"/> DED <input type="checkbox"/> RETENTION \$					AGGREGATE \$ 1,000,000.00
	<input checked="" type="checkbox"/> OCCUR <input type="checkbox"/> CLAIMS-MADE					Prod/Comp Ops Aggre \$ 1,000,000.00
	<input type="checkbox"/>					PER STATUTE <input type="checkbox"/> OTHER \$
<b>WORKERS COMPENSATION AND EMPLOYERS' LIABILITY</b> ANY PROPRIETOR/PARTNER/EXECUTIVE OFFICER/MEMBER EXCLUDED? (Mandatory in NH) If yes, describe under DESCRIPTION OF OPERATIONS below						E.L. EACH ACCIDENT \$
Y / N						E.L. DISEASE - EA EMPLOYEE \$
N / A						E.L. DISEASE - POLICY LIMIT \$

**DESCRIPTION OF OPERATIONS / LOCATIONS / VEHICLES (Attach ACORD 101, Additional Remarks Schedule, if more space is required)**  
Certificate holder is named as additional insured.  
Contract C-CAP-17-186-08-08 - Palm Subdivision  
Vehicles: 2014 Ford F250 Super Duty Crew Pickup, VIN#:1FT7W2BTBEC223386  
2006 Chev 1500 Pickup Extended, VIN#:1GCEC19Z16Z272601  
2002 Dodg Ram Pickup 2500 4x2, VIN#: 3B7KC26ZX2M288322

<b>CERTIFICATE HOLDER</b>  HIDALGO COUNTY PRECINCT ONE 1902 Joe Stephens Ave., Ste.101 Weslaco, TX 78599	<b>CANCELLATION</b>  SHOULD ANY OF THE ABOVE DESCRIBED POLICIES BE CANCELLED BEFORE THE EXPIRATION DATE THEREOF, NOTICE WILL BE DELIVERED IN ACCORDANCE WITH THE POLICY PROVISIONS.  AUTHORIZED REPRESENTATIVE  Mayra Crisanty/IV
--	---



# CERTIFICATE OF LIABILITY INSURANCE

DATE (MM/DD/YYYY)  
09/14/2017

THIS CERTIFICATE IS ISSUED AS A MATTER OF INFORMATION ONLY AND CONFERS NO RIGHTS UPON THE CERTIFICATE HOLDER. THIS CERTIFICATE DOES NOT AFFIRMATIVELY OR NEGATIVELY AMEND, EXTEND OR ALTER THE COVERAGE AFFORDED BY THE POLICIES BELOW. THIS CERTIFICATE OF INSURANCE DOES NOT CONSTITUTE A CONTRACT BETWEEN THE ISSUING INSURER(S), AUTHORIZED REPRESENTATIVE OR PRODUCER, AND THE CERTIFICATE HOLDER.

**IMPORTANT:** If the certificate holder is an ADDITIONAL INSURED, the policy(ies) must have ADDITIONAL INSURED provisions or be endorsed. If SUBROGATION IS WAIVED, subject to the terms and conditions of the policy, certain policies may require an endorsement. A statement on this certificate does not confer rights to the certificate holder in lieu of such endorsement(s).

<b>PRODUCER</b> Statewide Commercial Ins Brokers 2406 N Lake Avenue Altadena, CA 91001 Phone (877) 207-7900 Fax (626) 340-4807	<b>CONTACT NAME:</b> Customer Service <b>PHONE (A/C, No, Ext):</b> (877) 207-7900 <b>E-MAIL ADDRESS:</b> mail@st8wide.com	<b>FAX (A/C, No):</b> (626) 340-4807
	<b>INSURER(S) AFFORDING COVERAGE</b>	
<b>INSURED</b> Five Star Galaxy 4012 S. Cesar Chavez Rd. San Juan TX 78589	<b>INSURER A:</b> Rockingham Casualty Company	
	<b>INSURER B:</b> Infinity County Mutual Insurance Company	
	<b>INSURER C:</b> Commerce & Industry Ins Co	
	<b>INSURER D:</b>	
	<b>INSURER E:</b>	
<b>INSURER F:</b>		<b>NAIC #</b>

**COVERAGES**                      **CERTIFICATE NUMBER:**                      **REVISION NUMBER:** 1

THIS IS TO CERTIFY THAT THE POLICIES OF INSURANCE LISTED BELOW HAVE BEEN ISSUED TO THE INSURED NAMED ABOVE FOR THE POLICY PERIOD INDICATED. NOTWITHSTANDING ANY REQUIREMENT, TERM OR CONDITION OF ANY CONTRACT OR OTHER DOCUMENT WITH RESPECT TO WHICH THIS CERTIFICATE MAY BE ISSUED OR MAY PERTAIN, THE INSURANCE AFFORDED BY THE POLICIES DESCRIBED HEREIN IS SUBJECT TO ALL THE TERMS, EXCLUSIONS AND CONDITIONS OF SUCH POLICIES. LIMITS SHOWN MAY HAVE BEEN REDUCED BY PAID CLAIMS.

INSR LTR	TYPE OF INSURANCE	ADDL SUBR INSR / WVD	POLICY NUMBER	POLICY EFF (MM/DD/YYYY)	POLICY EXP (MM/DD/YYYY)	LIMITS	
A	<input checked="" type="checkbox"/> COMMERCIAL GENERAL LIABILITY <input type="checkbox"/> CLAIMS-MADE <input checked="" type="checkbox"/> OCCUR  GEN'L AGGREGATE LIMIT APPLIES PER: <input checked="" type="checkbox"/> POLICY <input type="checkbox"/> PRO-JECT <input type="checkbox"/> LOC <input type="checkbox"/> OTHER	Y	Y	RTXA500475	07/18/2017	07/18/2018	EACH OCCURRENCE \$ 1,000,000 DAMAGE TO RENTED PREMISES (Ea occurrence) \$ 50,000 MED EXP (Any one person) \$ 5,000 PERSONAL & ADV INJURY \$ 1,000,000 GENERAL AGGREGATE \$ 2,000,000 PRODUCTS - COMP/OP AGG \$ 2,000,000 \$
	<b>AUTOMOBILE LIABILITY</b> <input type="checkbox"/> ANY AUTO <input checked="" type="checkbox"/> SCHEDULED AUTOS <input type="checkbox"/> OWNED AUTOS ONLY <input checked="" type="checkbox"/> NON-OWNED AUTOS ONLY <input checked="" type="checkbox"/> HIRED AUTOS ONLY <input type="checkbox"/>	Y	Y	542-86002-1195-001	04/07/2017	04/07/2018	COMBINED SINGLE LIMIT (Ea accident) \$ 1,000,000 BODILY INJURY (Per person) \$ BODILY INJURY (Per accident) \$ PROPERTY DAMAGE (Per accident) \$ Uninsured Motorist \$ 1,000,000
C	<input type="checkbox"/> UMBRELLA LIAB <input checked="" type="checkbox"/> OCCUR <input checked="" type="checkbox"/> EXCESS LIAB <input type="checkbox"/> CLAIMS-MADE <input type="checkbox"/> DED <input type="checkbox"/> RETENTION \$	Y	Y	EBU 023511293	08/28/2017	08/28/2018	EACH OCCURRENCE \$ 1,000,000 AGGREGATE \$ 1,000,000 Prod/Comp Ops Agg \$ 1,000,000
	<b>WORKERS COMPENSATION AND EMPLOYERS' LIABILITY</b> ANY PROPRIETOR/PARTNER/EXECUTIVE OFFICER/MEMBER EXCLUDED? <input type="checkbox"/> N/A (Mandatory In NH) If yes, describe under DESCRIPTION OF OPERATIONS below						<input type="checkbox"/> PER STATUTE <input type="checkbox"/> OTHER E.L. EACH ACCIDENT \$ E.L. DISEASE - EA EMPLOYEE \$ E.L. DISEASE - POLICY LIMIT \$

DESCRIPTION OF OPERATIONS / LOCATIONS / VEHICLES (Attach ACORD 101, Additional Remarks Schedule, if more space is required)

Certificate holder is named as additional insured.  
 Contract C-CAP-17-186-08-08 - Palm Subdivision  
 Vehicles: 2014 Ford F250 Super Duty Crew Pickup, VIN#: 1FT7W2BTBEC223386  
 2006 Chev 1500 Pickup Extended, VIN#: 1GCEC19Z16Z272601  
 2002 Dodg Ram Pickup 2500 4x2, VIN#: 3B7KC26ZX2M288322

**CERTIFICATE HOLDER****CANCELLATION**

HIDALGO COUNTY PRECINCT ONE  
 1902 Joe Stephens Ave., Ste. 101  
 Weslaco, TX 78599

SHOULD ANY OF THE ABOVE DESCRIBED POLICIES BE CANCELLED BEFORE THE EXPIRATION DATE THEREOF, NOTICE WILL BE DELIVERED IN ACCORDANCE WITH THE POLICY PROVISIONS.

AUTHORIZED REPRESENTATIVE



September 14, 2017

De Hoyos, Sorais Alma  
4012 Cesar Chavez Rd  
San Juan, TX 78589

**RE: POLICY NUMBER: 542-86002-1195-001**  
**INFINITY COUNTY MUTUAL INSURANCE COMPANY NAIC 13820**  
**AUTOMOBILE INSURANCE COVERAGE**

TO WHOM IT MAY CONCERN:

Please be advised that De Hoyos, Sorais Alma has/had coverage with our company under policy #542-86002-1195-001. The effective dates of the policy covering the vehicles are from 04/07/2017 to 04/07/2018 12:01AM CST. The current term of this policy is from 04/07/2017 to 04/07/2018. At this time our Infinity policy does not show any lapses in coverage.

The rated drivers listed on the policy are/were as follows:

De Hoyos, Sorais Alma DL# 09005224 Loera, Samuel DL# 19754597  
De Hoyos, Israel DL# 33397338

Liability Coverages: BI-1000000/1000000 PD-1000000 HABI- HAPD- NOBI- NOPD- RA-75/75  
UMBI-1000000/1000000

2014 Ford F250 Super Duty Crew 1FT7W2BTBEC223386 COL-1000 COM-1000

2006 Chev 1500 Pickup Extended 1GCEC19Z16Z272601 COL-1000 COM-1000 was added on 08/03/2017.

2002 Dodg Ram Pickup 2500 4x2 3B7KC26ZX2M288322 COL-1000 COM-1000 was added on 08/03/2017.

If you have any questions, please feel free to contact any of our Customer Service Consultants at 1-800-722-3391.

Sincerely,

Joy Lietch  
Manager, Specialty Auto

## **GENERAL CONDITIONS OF THE AGREEMENT**

### **1. GENERAL**

It is the intent of these instructions, plans and specifications to provide guidance for the construction of this project.

### **2. REGULATIONS AND DISCREPANCIES**

All applicable laws, ordinances, policy, rules, regulations and other directives of all authorities having jurisdiction over the projects shall apply to the contract throughout and will be deemed to be included in the contract the same as those written out in full. Discrepancies between regulations or conflicting parts of the Specifications shall be brought to the attention of an clarified by the Engineer before proceeding with any work. Proceeding with affected work without instructions from the Engineer can result in the Contractor being responsible for taking the necessary steps to insure the work conforms to the governing regulation.

### **3. ENGINEER**

Whenever the work "ENGINEER" is used in this contract with reference to the preparation of plans, specifications, and contract documents, it shall be understood as referring to the firm **Javier Hinojosa Engineering**.

### **4. INTERPRETATION OF PHRASES**

Whenever the words "Directed", "Required", "Permitted", "Designated", "Considered Necessary", "Prescribed", or words of like importance are used, it shall be understood that the direction, requirements, permission, order, designation or prescription, of the ENGINEER is intended and similarly, the words "Approval", "Acceptable", "Satisfactory", or words of like importance shall mean approved by or acceptable of satisfactory to the ENGINEER. The preceeding to the contrary notwithstanding, Engineer's approval or acceptance of the work shall by advisory to OWNER, and shall not bind the OWNER to accept or approve the same.

Whenever, in the specifications or drawings accompanying this agreement, the terms or description of various qualities relative to finish, workmanship, or other qualities of similar kind which cannot,, from their nature, be specifically and clearly described and specified, but are necessarily described in general terms, then, in all such cases, any question of the fulfillment of said specifications shall be decided by the ENGINEER, and said work shall be done in accordance with his interpretations of the meaning of the words, terms, or clauses defining the character of the work.

# Title 29 - LABOR

## Subtitle A - Office of the Secretary of Labor

### PART 3 - CONTRACTORS AND SUBCONTRACTORS ON PUBLIC BUILDING OR PUBLIC WORK FINANCED IN WHOLE OR IN PART BY LOANS OR GRANTS FROM THE UNITED STATES

- Sec.
- 3.1 Purpose and scope
  - 3.2 Definitions
  - 3.3 Weekly statement with respect to payment of wages
  - 3.4 Submission of weekly statements and the preservation and inspection of weekly payroll records.
  - 3.5 Payroll deductions permissible without application to or approval of the Secretary of Labor.
  - 3.6 Payroll deductions permissible with the approval of the Secretary of Labor.
  - 3.7 Applications for the approval of the Secretary of Labor
  - 3.8 Action by the Secretary of Labor upon applications.
  - 3.9 Prohibited payroll deductions.
  - 3.10 Methods of payment of wages.
  - 3.11 Regulations part of contract.

**AUTHORITY:** The provisions of this Part 3 issued under R.S. 16 1, sec. 2, 48 Stat. §48; Reorg. Plan No. 14 of 1950, 64 Stat. 1267, 5 U.S.C. Appendix; 5 U.S.C. 301; 40 U.S.C. 276c.

**SOURCE:** The provisions of this Part 3 appear at 29 F.R. 97, Jan. 4, 1964, unless otherwise noted.

#### Section 3.1 Purpose and Scope.

This part prescribes "anti-kickback" regulations under section 2 of the Act of June 13, 1934, as amended (40 U.S.C. 276c), popularly known as the Copeland Act. This part applies to any contract which is subject to Federal wage standards and which is for the construction, prosecution, completion, or repair of public buildings, public works or buildings or works financed in whole or in part by loans or grants from the United States. The part is intended to aid in the enforcement of the minimum wage provisions of the Davis-Bacon Act and the various statutes dealing with Federally assisted construction that contain similar minimum wage provisions, including those provisions which are not subject to Reorganization

Plan No. 14 (e.g., the College Housing Act of 1950, the Federal Water Pollution Control Act, and the Housing Act of 1959), and in the enforcement of the overtime provisions of the Contract Work Hours Standards Act whenever they are applicable to construction work. The part details the obligation of contractors and subcontractors relative to the weekly submission of statements regarding the wages paid on work covered thereby; sets forth the circumstances and procedures governing the making of payroll deductions from the wages of those employed on such work; and delineates the methods of payment permissible on such work.

#### Section 3.2 Definitions.

As used in the regulations in this part:

(a) The terms "building" or "work" generally include construction activity as distinguished from manufacturing, furnishing of materials, or servicing and maintenance work. The terms include, without limitation, buildings, structures, and improvements of all @s, such as bridges, dams, plants, highways, parkways, streets, subways, tunnels, sewers, mains, powerlines, pumping stations, railways, airports, terminals, docks, piers, wharves, ways, lighthouses, buoys, jetties, breakwaters, levees, and canals; dredging, shoring, scaffolding, drilling, blasting, excavating, clearing, and landscaping. Unless conducted in connection with and at the site of such a building or work as is described in the foregoing sentence, the manufacture or furnishing of materials, articles, supplies, or equipment (whether or not a Federal or State agency acquires title to such materials,

#### *Copeland Act Regulations*

articles, supplies, or equipment during the course of the manufacture or furnishing, or owns the materials from which they are manufactured or furnished) is not a "building" or "work" within the meaning of the regulations in this part.

(b) The terms construction," 4; prosecution," @'completion," or repair" mean all types of work done on a particular building or work at the site thereof, including, without limitation, altering, remodeling, painting and decorating, the transporting of materials and supplies to or from the building or work by the employees of the construction contractor or construction subcontractor, and the manufacturing or furnishing of materials, articles, supplies, or equipment on the site of the building or work, by persons employed at the site by the contractor or subcontractor.

(c) The terms "public building" or "public work" include building or work for whose construction, prosecution, completion, or repair, as defined above, a Federal agency is a contracting party, regardless of whether title thereof is in a Federal agency.

(d) The term "building or work financed in whole or in part by loans or grants from the United States" includes building or work for whose construction, prosecution, completion, or repair, as defined above, payment or part payment is made directive or indirectly from funds provided by loans or grants by a Federal agency. The term includes building or work for which the Federal assistance granted is in the form of loan guarantees or insurance.

(e) Every person paid by a contractor or subcontractor in any manner for his labor in the construction, prosecution, completion, or repair of a public building or public work or building or work financed in whole or in part by loans or grants from the United States is "employed" and receiving 44 wages," regardless of any contractual relationship alleged to exist between him and the real employer.

(f) The term "any affiliated person" includes a spouse, child, parent, or other close relative of the contractor or subcontractor; a partner or officer of the contractor or subcontractor; a corporation closely connected with the contractor or subcontractor as parent, subsidiary or otherwise, and an officer or agent of such corporation.

(g) The term "Federal agency" means the United States, the District of Columbia, and all executive departments, independent establishments, administrative agencies, and instrumentality's of the United States and of the District of Columbia, including corporations. all or substantially all of the stock of which is beneficially owned by the United States, by the District of Columbia, or any of the foregoing departments, establishments, agencies, and

(a) Each weekly statement required under §3.3 shall be delivered by the contractor or subcontractor, within seven days after the regular payment date of the payroll period, to a representative of a Federal or

instrumentality's.

(29 FR 97, Jan. 4, 1964, as amended at 33 FR 32575, Nov. 27, 1973)

### **Section 3.3 Weekly statement with respect to payment of wages.**

(a) As used in this section, the term "employee" shall not apply to persons in classifications higher than that of laborer or mechanic and those who are the immediate supervisors of such employees.

(b) Each contractor or subcontractor engaged in the construction, prosecution, completion, or repair of any public building or public work, or building or work financed in whole or in part by loans or grants from the United States, shall furnish each week a statement with respect to the wages paid each of its employees engaged on work covered by 29 CFR Parts 3 and 5 during the preceding weekly payroll period. This statement shall be executed by the contractor or subcontractor or by an authorized officer of employee of the contractor or subcontractor who supervises the payment of wages, and shall be on form @ 348, "Statement of Compliance," or on an identical form on the back of @ 347, "Payroll (For Contractors Optional Use)" or on any form with identical wording. Sample copies of @ 347 and @ 348 may be obtained from the Government contracting or sponsoring agency, and copies of these forms may be purchased at the Government Printing Office.

(c) The requirements of this section shall not apply to any contract of \$2,000 or less.

(d) Upon a written finding by the head of a Federal agency, the Secretary of Labor may provide reasonable limitations, variations, tolerances, and exemptions from the requirements of this section subject to such conditions as the Secretary of Labor may specify.  
(29 F.R. 95, Jan. 4, 19(A, as ==tied at 33 F.R. 10186, July 17,1968)

### *Copeland Act Regulations*

### **Section 3.4 Submission of weekly statements and the preservation and inspection of weekly payroll records.**

State agency in charge at the site of the building or work, or if there is no representative of a Federal or State agency at the site of the building or work, the statement shall be mailed by the contractor or

subcontractor, within such time, to a Federal or State agency contracting for or financing the building or work. After such examination and check as may be made, such statement, or a copy thereof, shall be kept available, or shall be transmitted together with a report of any violation, in accordance with applicable procedures prescribed by the United States Department of Labor.

(b) Each contractor or subcontractor shall preserve his weekly payroll records for a period of three years from date of completion of the contract. The payroll records shall set out accurately and completely the name and address of each laborer and mechanic, his correct classification, rate of pay, daily and weekly number of hours worked, deductions made, and actual wages paid. Such payroll records shall be made available at all times for inspection by the contracting officer or his authorized representative, and by authorized representatives of the Department of Labor.

### **Section 3.5 Payroll deductions permissible without application to or approval of the Secretary of Labor.**

Deductions made under the circumstances or in the situations described in the paragraphs of this section may be made without application to and approval of the Secretary of Labor:

(a) Any deduction made in compliance with the requirements of Federal, State, or local law, such as Federal or State withholding income taxes and Federal social security taxes.

(b) Any deduction of sums previously paid to the employee as a bona fide prepayment of wages when such prepayment is made without discount or interest. A "bona fide prepayment of wages" is considered to have been made only when cash or its equivalent has been advanced to the person employed in such manner as to give him complete freedom of disposition of the advanced funds.

(c) Any deduction of amounts required by court process to be paid to another, unless, the deduction is in favor of the contractor, subcontractor or any affiliated person, or when collusion or collaboration exists.

(d) Any deduction constituting a contribution on behalf of the person employed to funds established by the employer or representatives of employees, or both, for the purpose of providing either from principal or income, or both, medical or hospital care, pensions, or annuities on retirement, death benefits, compensation for injuries, illness, accidents, sickness,

(k) Any deduction for the cost of safety equipment of nominal value purchased by the

or disability, or for insurance to provide any of the foregoing, or unemployment benefits, vacation pay, savings accounts, or similar payments for the benefit of employees, their families and dependents: Provided, however, That the following standards are met: (1) The deduction is not otherwise prohibited by law; (2) it is either: (i) Voluntarily consented to by the employee in writing and in advance of the period in which the work is to be done and such consent is not a condition either for the obtaining of or for the continuation of employment, or (ii) provided for in a bona fide collective bargaining agreement between the contractor or subcontractor and representatives of its employees; (3) no profit or other benefit is otherwise obtained, directly or indirectly, by the contractor or subcontractor or any affiliated person in the form of commission, dividend, or otherwise; and (4) the deductions shall serve the convenience and interest of the employee. (e) Any deduction contributing toward the purchase of United States Defense Stamps and Bonds when voluntarily authorized by the employee.

(f) Any deduction requested by the employee to enable him to repay loans to or to purchase shares in credit unions organized and operated in accordance with Federal and State credit union statutes.

(g) Any deduction voluntarily authorized by the employee for the making of contributions to

#### *Copeland Act Regulations*

governmental or quasi-governmental agencies, such as the American Red Cross.

(h) Any deduction voluntarily authorized by the employee for the making of contributions to Community Chests, United Givers Funds, and similar charitable organizations.

(i) Any deductions to pay regular union initiation fees and membership dues, not including fines or special assessments: Provided, however, That a collective bargaining agreement between the contractor or subcontractor and representatives of its employees provides for such deductions and the deductions are not otherwise prohibited by law.

(j) Any deduction not more than for the "reasonable cost" of board, lodging, or other facilities meeting the requirements of section 3(m) of the Fair Labor Standards Act of 1938, as amended, and Part 531 of this title. When such a deduction is made the additional records required under §516.27(a) of this title shall be kept.

employee as his own prope@ for his personal protection in his work, such as safety shoes, safety

glasses, safety gloves, and hard hats, if such equipment is not required by law to be furnished by the employer, if such deduction is not violative of the Fair Labor Standards Act or prohibited by other law, if the cost on which the deduction is based does not exceed the actual cost to the employer where the equipment is purchased from him and does not include any direct or indirect monetary return to the employer where the equipment is purchased from a third person, and if the deduction is either (1) voluntarily consented to be the employee in writing and in advance of the period in which the work is to be done and such consent is not a condition either for the obtaining of employment or its continuance; or (2) provided for in a bona fide collective bargaining agreement between the contractor or subcontractor and representatives of its employees.

(36 F.R. 9770, May 28, 1971.)

### **Section 3.6 Payroll deductions permissible with the approval of the Secretary of Labor.**

Any contractor or subcontractor may apply to the Secretary of Labor for permission to make any

deduction not permitted under §3.5. The Secretary may grant permission whenever he finds that:

- (a) The contractor, subcontractor, or any affiliated person does not make a profit or benefit

directly or indirectly from the deduction either in the form of a commission, dividend, or otherwise;

- (b) The deduction is not otherwise prohibited by law;

- (c) The deduction is either (1) voluntarily consented to by the employee in writing and in advance of the period in which the work is to be done and such consent is not a condition either for the obtaining of employment or its continuance, or (2) provided for in a bona fide collective bargaining agreement between the contractor or subcontractor and representatives of its employees; and

- (d) The deduction serves the convenience and interest of the employee.

### **Section 3.7 Applications for the approval of the Secretary of Labor.**

Any application for the making of payroll deductions under §3.6 shall comply with the requirements prescribed in the following paragraphs of this section:

- (a) The application shall be in writing and shall be addressed to the Secretary of Labor.

- (b) The application need not identify the

contract or contracts under which the work in question is to be performed. Permission will be given for deductions on all current and future contracts of the applicant for a period of 1 year. A renewal of permission to make such payroll deduction will be granted upon the submission of an application which makes reference to the original application, recites the date of the Secretary of Labor's approval of such deductions, states affirmatively that there is continued compliance with the standards set forth in the provisions of §3.6, and specifies any conditions which have changed in regard to the payroll deductions.

(36 F.IL 9770, May 29, 1971.)

- (c) The application shall state affirmatively that there is compliance with the standards set forth in the provisions of §3.6. The affirmation shall be accompanied by a full statement of the facts indicating such compliance.

### *Copeland Act Regulations*

(d) The application shall include a description of the proposed deduction, the purpose to be served there by, and the classes of laborers or mechanics from whose wages the proposed deduction would be made.

(e) The application shall state the name and business of any third person to whom any funds obtained from the proposed deductions are to be transmitted and the affiliation of such person, if any, with the applicant. -

#### **Section 3.8 Action by the Secretary of Labor upon applications.**

The Secretary of Labor shall decide whether or not the requested deduction is permissible under provisions of §3.6; and shall notify the applicant in writing of his decision.

#### **Section 3.9 Prohibited payroll deductions.**

Deductions not elsewhere provided for by this part and which are not found to be permissible under §3.6 are prohibited.

#### **Section 3.10 Methods of payment of wages.**

The payment of wages shall be by cash, negotiable instruments payable on demand, or the additional forms of compensation for which deductions are permissible under this part. No other methods of payment shall be recognized on work subject to the Copeland Act.

#### **Section 3.11 Regulations part of contract.**

All contracts made with respect to the construction, prosecution, completion, or repair of any public building or public work or building or work financed in whole or in part by loans or grants from the United States covered by the regulations in this part shall expressly bind the contractor or subcontractor to comply with such of the regulations in this part as may be applicable. In this regard, see §5.5(a) of this subtitle.

**STANDARD  
GENERAL CONDITIONS  
OF THE  
CONSTRUCTION CONTRACT**

Prepared by

**ENGINEERS JOINT CONTRACT DOCUMENTS COMMITTEE**

and

Issued and Published Jointly By

**PROFESSIONAL ENGINEERS IN PRIVATE PRACTICE**  
*a practice division of the*  
**NATIONAL SOCIETY OF PROFESSIONAL ENGINEERS**

---

**AMERICAN CONSULTING ENGINEERS COUNCIL**

---

**AMERICAN SOCIETY OF CIVIL ENGINEERS**

This document has been approved and endorsed by

**The Associated General Contractors of America**

**Construction Specifications Institute**

Copyright ©1996

National Society of Professional Engineers  
1420 King Street, Alexandria, VA 22314

American Consulting Engineers Council  
1015 15th Street N.W., Washington, DC 20005

American Society of Civil Engineers  
345 East 47th Street, New York, NY 10017

**TABLE OF CONTENTS**

	<u>Page</u>
ARTICLE 1 - DEFINITIONS AND TERMINOLOGY .....	6
1.01 <i>Defined Terms</i> .....	6
1.02 <i>Terminology</i> .....	8
ARTICLE 2 - PRELIMINARY MATTERS .....	9
2.01 <i>Delivery of Bonds</i> .....	9
2.02 <i>Copies of Documents</i> .....	9
2.03 <i>Commencement of Contract Times; Notice to Proceed</i> .....	9
2.04 <i>Starting the Work</i> .....	9
2.05 <i>Before Starting Construction</i> .....	9
2.06 <i>Preconstruction Conference</i> .....	10
2.07 <i>Initial Acceptance of Schedules</i> .....	10
ARTICLE 3 - CONTRACT DOCUMENTS: INTENT, AMENDING, REUSE.....	10
3.01 <i>Intent</i> .....	10
3.02 <i>Reference Standards</i> .....	10
3.03 <i>Reporting and Resolving Discrepancies</i> .....	10
3.04 <i>Amending and Supplementing Contract Documents</i> .....	11
3.05 <i>Reuse of Documents</i> .....	11
ARTICLE 4 - AVAILABILITY OF LANDS; SUBSURFACE AND PHYSICAL CONDITIONS; REFERENCE POINTS.....	11
4.01 <i>Availability of Lands</i> .....	11
4.02 <i>Subsurface and Physical Conditions</i> .....	12
4.03 <i>Differing Subsurface or Physical Conditions</i> .....	12
4.04 <i>Underground Facilities</i> .....	13
4.05 <i>Reference Points</i> .....	13
4.06 <i>Hazardous Environmental Condition at Site</i> .....	14
ARTICLE 5 - BONDS AND INSURANCE.....	15
5.01 <i>Performance, Payment, and Other Bonds</i> .....	15
5.02 <i>Licensed Sureties and Insurers</i> .....	15
5.03 <i>Certificates of Insurance</i> .....	15
5.04 <i>CONTRACTOR's Liability Insurance</i> .....	15
5.05 <i>OWNER's Liability Insurance</i> .....	16
5.06 <i>Property Insurance</i> .....	16
5.07 <i>Waiver of Rights</i> .....	17
5.08 <i>Receipt and Application of Insurance Proceeds</i> .....	18
5.09 <i>Acceptance of Bonds and Insurance; Option to Replace</i> .....	18
5.10 <i>Partial Utilization, Acknowledgment of Property Insurer</i> .....	18
ARTICLE 6 - CONTRACTOR'S RESPONSIBILITIES .....	18
6.01 <i>Supervision and Superintendence</i> .....	18
6.02 <i>Labor; Working Hours</i> .....	19
6.03 <i>Services, Materials, and Equipment</i> .....	19
6.04 <i>Progress Schedule</i> .....	19
6.05 <i>Substitutes and "Or-Equals"</i> .....	19
6.06 <i>Concerning Subcontractors, Suppliers, and Others</i> .....	21

6.07 Patent Fees and Royalties .....	21
6.08 Permits .....	22
6.09 Laws and Regulations .....	22
6.10 Taxes .....	22
6.11 Use of Site and Other Areas .....	22
6.12 Record Documents .....	22
6.13 Safety and Protection .....	23
6.14 Safety Representative .....	23
6.15 Hazard Communication Programs .....	23
6.16 Emergencies .....	23
6.17 Shop Drawings and Samples .....	24
6.18 Continuing the Work .....	25
6.19 CONTRACTOR's General Warranty and Guarantee .....	25
6.20 Indemnification .....	25
ARTICLE 7 - OTHER WORK .....	26
7.01 Related Work at Site .....	26
7.02 Coordination .....	26
ARTICLE 8 - OWNER'S RESPONSIBILITIES .....	27
8.01 Communications to Contractor .....	27
8.02 Replacement of ENGINEER .....	27
8.03 Furnish Data .....	27
8.04 Pay Promptly When Due .....	27
8.05 Lands and Easements; Reports and Tests .....	27
8.06 Insurance .....	27
8.07 Change Orders .....	27
8.08 Inspections, Tests, and Approvals .....	27
8.09 Limitations on OWNER's Responsibilities .....	27
8.10 Undisclosed Hazardous Environmental Condition .....	27
8.11 Evidence of Financial Arrangements .....	27
ARTICLE 9 - ENGINEER'S STATUS DURING CONSTRUCTION .....	27
9.01 OWNER'S Representative .....	27
9.02 Visits to Site .....	28
9.03 Project Representative .....	28
9.04 Clarifications and Interpretations .....	28
9.05 Authorized Variations in Work .....	28
9.06 Rejecting Defective Work .....	29
9.07 Shop Drawings, Change Orders and Payments .....	29
9.08 Determinations for Unit Price Work .....	28
9.09 Decisions on Requirements of Contract Documents and Acceptability of Work .....	28
9.10 Limitations on ENGINEER's Authority and Responsibilities .....	28
ARTICLE 10 - CHANGES IN THE WORK; CLAIMS .....	29
10.01 Authorized Changes in the Work .....	29
10.02 Unauthorized Changes in the Work .....	29
10.03 Execution of Change Orders .....	30
10.04 Notification to Surety .....	30
10.05 Claims and Disputes .....	30
ARTICLE 11 - COST OF THE WORK; CASH ALLOWANCES; UNIT PRICE WORK .....	30
11.01 Cost of the Work .....	30

11.02 <i>Cash Allowances</i> .....	32
11.03 <i>Unit Price Work</i> .....	33
ARTICLE 12 - CHANGE OF CONTRACT PRICE; CHANGE OF CONTRACT TIMES.....	33
12.01 <i>Change of Contract Price</i> .....	33
12.02 <i>Change of Contract Times</i> .....	34
12.03 <i>Delays Beyond CONTRACTOR's Control</i> .....	34
12.04 <i>Delays Within CONTRACTOR's Control</i> .....	34
12.05 <i>Delays Beyond OWNER's and CONTRACTOR'S Control</i> .....	34
12.06 <i>Delay Damages</i> .....	34
ARTICLE 13 - TESTS AND INSPECTIONS; CORRECTION, REMOVAL OR ACCEPTANCE OF DEFECTIVE WORK.....	34
13.01 <i>Notice of Defects</i> .....	34
13.02 <i>Access to Work</i> .....	34
13.03 <i>Tests and Inspections</i> .....	35
13.04 <i>Uncovering Work</i> .....	35
13.05 <i>OWNER May Stop the Work</i> .....	35
13.06 <i>Correction or Removal of Defective Work</i> .....	36
13.07 <i>Correction Period</i> .....	36
13.08 <i>Acceptance of Defective Work</i> .....	36
13.09 <i>OWNER May Correct Defective Work</i> .....	36
ARTICLE 14 - PAYMENTS TO CONTRACTOR AND COMPLETION .....	37
14.01 <i>Schedule of Values</i> .....	37
14.02 <i>Progress Payments</i> .....	37
14.03 <i>CONTRACTOR's Warranty of Title</i> .....	38
14.04 <i>Substantial Completion</i> .....	39
14.05 <i>Partial Utilization</i> .....	39
14.06 <i>Final Inspection</i> .....	39
14.07 <i>Final Payment</i> .....	40
14.08 <i>Final Completion Delayed</i> .....	40
14.09 <i>Waiver of Claims</i> .....	41
ARTICLE 15 - SUSPENSION OF WORK AND TERMINATION.....	41
15.01 <i>OWNER May Suspend Work</i> .....	41
15.02 <i>OWNER May Terminate for Cause</i> .....	41
15.03 <i>OWNER May Terminate For Convenience</i> .....	41
15.04 <i>CONTRACTOR May Stop Work or Terminate</i> .....	42
ARTICLE 16 - DISPUTE RESOLUTION .....	42
16.01 <i>Methods and Procedures</i> .....	42
ARTICLE 17 - MISCELLANEOUS.....	43
17.01 <i>Giving Notice</i> .....	43
17.02 <i>Computation of Times</i> .....	43
17.03 <i>Cumulative Remedies</i> .....	43
17.04 <i>Survival of Obligations</i> .....	43
17.05 <i>Controlling Law</i> .....	43

## GENERAL CONDITIONS

### ARTICLE 1 - DEFINITIONS AND TERMINOLOGY

---

#### 1.01 *Defined Terms*

A. Wherever used in the Contract Documents and printed with initial or all capital letters, the terms listed below will have the meanings indicated which are applicable to both the singular and plural thereof.

1. *Addenda*--Written or graphic instruments issued prior to the opening of Bids which clarify, correct, or change the Bidding Requirements or the Contract Documents.

2. *Agreement*--The written instrument which is evidence of the agreement between OWNER and CONTRACTOR covering the Work.

3. *Application for Payment*--The form acceptable to ENGINEER which is to be used by CONTRACTOR during the course of the Work in requesting progress or final payments and which is to be accompanied by such supporting documentation as is required by the Contract Documents.

4. *Asbestos*--Any material that contains more than one percent asbestos and is friable or is releasing asbestos fibers into the air above current action levels established by the United States Occupational Safety and Health Administration.

5. *Bid*--The offer or proposal of a bidder submitted on the prescribed form setting forth the prices for the Work to be performed.

6. *Bidding Documents*--The Bidding Requirements and the proposed Contract Documents (including all Addenda issued prior to receipt of Bids).

7. *Bidding Requirements*--The Advertisement or Invitation to Bid, Instructions to Bidders, Bid security form, if any, and the Bid form with any supplements.

8. *Bonds*--Performance and payment bonds and other instruments of security.

9. *Change Order*--A document recommended by ENGINEER which is signed by CONTRACTOR and OWNER and authorizes an addition, deletion, or revision in the Work or an adjustment in the Contract Price or the

Contract Times, issued on or after the Effective Date of the Agreement.

10. *Claim*--A demand or assertion by OWNER or CONTRACTOR seeking an adjustment of Contract Price or Contract Times, or both, or other relief with respect to the terms of the Contract. A demand for money or services by a third party is not a Claim.

11. *Contract*--The entire and integrated written agreement between the OWNER and CONTRACTOR concerning the Work. The Contract supersedes prior negotiations, representations, or agreements, whether written or oral.

12. *Contract Documents*--The Contract Documents establish the rights and obligations of the parties and include the Agreement, Addenda (which pertain to the Contract Documents), CONTRACTOR's Bid (including documentation accompanying the Bid and any post Bid documentation submitted prior to the Notice of Award) when attached as an exhibit to the Agreement, the Notice to Proceed, the Bonds, these General Conditions, the Supplementary Conditions, the Specifications and the Drawings as the same are more specifically identified in the Agreement, together with all Written Amendments, Change Orders, Work Change Directives, Field Orders, and ENGINEER's written interpretations and clarifications issued on or after the Effective Date of the Agreement. Approved Shop Drawings and the reports and drawings of subsurface and physical conditions are not Contract Documents. Only printed or hard copies of the items listed in this paragraph are Contract Documents. Files in electronic media format of text, data, graphics, and the like that may be furnished by OWNER to CONTRACTOR are not Contract Documents.

13. *Contract Price*--The moneys payable by OWNER to CONTRACTOR for completion of the Work in accordance with the Contract Documents as stated in the Agreement (subject to the provisions of paragraph 11.03 in the case of Unit Price Work).

14. *Contract Times*--The number of days or the dates stated in the Agreement to: (i) achieve Substantial Completion; and (ii) complete the Work so that it is ready for final payment as evidenced by ENGINEER's written recommendation of final payment.

15. *CONTRACTOR*--The individual or entity with whom OWNER has entered into the Agreement.

16. *Cost of the Work*—See paragraph 11.01.A for definition.

17. *Drawings*—That part of the Contract Documents prepared or approved by ENGINEER which graphically shows the scope, extent, and character of the Work to be performed by CONTRACTOR. Shop Drawings and other CONTRACTOR submittals are not Drawings as so defined.

18. *Effective Date of the Agreement*—The date indicated in the Agreement on which it becomes effective, but if no such date is indicated, it means the date on which the Agreement is signed and delivered by the last of the two parties to sign and deliver.

19. *ENGINEER*—The individual or entity named as such in the Agreement.

20. *ENGINEER's Consultant*—An individual or entity having a contract with ENGINEER to furnish services as ENGINEER's independent professional associate or consultant with respect to the Project and who is identified as such in the Supplementary Conditions.

21. *Field Order*—A written order issued by ENGINEER which requires minor changes in the Work but which does not involve a change in the Contract Price or the Contract Times.

22. *General Requirements*—Sections of Division 1 of the Specifications. The General Requirements pertain to all sections of the Specifications.

23. *Hazardous Environmental Condition*—The presence at the Site of Asbestos, PCBs, Petroleum, Hazardous Waste, or Radioactive Material in such quantities or circumstances that may present a substantial danger to persons or property exposed thereto in connection with the Work.

24. *Hazardous Waste*—The term Hazardous Waste shall have the meaning provided in Section 1004 of the Solid Waste Disposal Act (42 USC Section 6903) as amended from time to time.

25. *Laws and Regulations; Laws or Regulations*—Any and all applicable laws, rules, regulations, ordinances, codes, and orders of any and all governmental bodies, agencies, authorities, and courts having jurisdiction.

26. *Liens*—Charges, security interests, or encumbrances upon Project funds, real property, or personal property.

27. *Milestone*—A principal event specified in the Contract Documents relating to an intermediate completion date or time prior to Substantial Completion of all the Work.

28. *Notice of Award*—The written notice by OWNER to the apparent successful bidder stating that upon timely compliance by the apparent successful bidder with the conditions precedent listed therein, OWNER will sign and deliver the Agreement.

29. *Notice to Proceed*—A written notice given by OWNER to CONTRACTOR fixing the date on which the Contract Times will commence to run and on which CONTRACTOR shall start to perform the Work under the Contract Documents.

30. *OWNER*—The individual, entity, public body, or authority with whom CONTRACTOR has entered into the Agreement and for whom the Work is to be performed.

31. *Partial Utilization*—Use by OWNER of a substantially completed part of the Work for the purpose for which it is intended (or a related purpose) prior to Substantial Completion of all the Work.

32. *PCBs*—Polychlorinated biphenyls.

33. *Petroleum*—Petroleum, including crude oil or any fraction thereof which is liquid at standard conditions of temperature and pressure (60 degrees Fahrenheit and 14.7 pounds per square inch absolute), such as oil, petroleum, fuel oil, oil sludge, oil refuse, gasoline, kerosene, and oil mixed with other non-Hazardous Waste and crude oils.

34. *Project*—The total construction of which the Work to be performed under the Contract Documents may be the whole, or a part as may be indicated elsewhere in the Contract Documents.

35. *Project Manual*—The bound documentary information prepared for bidding and constructing the Work. A listing of the contents of the Project Manual, which may be bound in one or more volumes, is contained in the table(s) of contents.

36. *Radioactive Material*--Source, special nuclear, or byproduct material as defined by the Atomic Energy Act of 1954 (42 USC Section 2011 et seq.) as amended from time to time.

37. *Resident Project Representative*--The authorized representative of ENGINEER who may be assigned to the Site or any part thereof.

38. *Samples*--Physical examples of materials, equipment, or workmanship that are representative of some portion of the Work and which establish the standards by which such portion of the Work will be judged.

39. *Shop Drawings*--All drawings, diagrams, illustrations, schedules, and other data or information which are specifically prepared or assembled by or for CONTRACTOR and submitted by CONTRACTOR to illustrate some portion of the Work.

40. *Site*--Lands or areas indicated in the Contract Documents as being furnished by OWNER upon which the Work is to be performed, including rights-of-way and easements for access thereto, and such other lands furnished by OWNER which are designated for the use of CONTRACTOR.

41. *Specifications*--That part of the Contract Documents consisting of written technical descriptions of materials, equipment, systems, standards, and workmanship as applied to the Work and certain administrative details applicable thereto.

42. *Subcontractor*--An individual or entity having a direct contract with CONTRACTOR or with any other Subcontractor for the performance of a part of the Work at the Site.

43. *Substantial Completion*--The time at which the Work (or a specified part thereof) has progressed to the point where, in the opinion of ENGINEER, the Work (or a specified part thereof) is sufficiently complete, in accordance with the Contract Documents, so that the Work (or a specified part thereof) can be utilized for the purposes for which it is intended. The terms "substantially complete" and "substantially completed" as applied to all or part of the Work refer to Substantial Completion thereof.

44. *Supplementary Conditions*--That part of the Contract Documents which amends or supplements these General Conditions.

45. *Supplier*--A manufacturer, fabricator, supplier, distributor, materialman, or vendor having a direct contract with CONTRACTOR or with any Subcontractor to furnish materials or equipment to be incorporated in the Work by CONTRACTOR or any Subcontractor.

46. *Underground Facilities*--All underground pipelines, conduits, ducts, cables, wires, manholes, vaults, tanks, tunnels, or other such facilities or attachments, and any encasements containing such facilities, including those that convey electricity, gases, steam, liquid petroleum products, telephone or other communications, cable television, water, wastewater, storm water, other liquids or chemicals, or traffic or other control systems.

47. *Unit Price Work*--Work to be paid for on the basis of unit prices.

48. *Work*--The entire completed construction or the various separately identifiable parts thereof required to be provided under the Contract Documents. Work includes and is the result of performing or providing all labor, services, and documentation necessary to produce such construction, and furnishing, installing, and incorporating all materials and equipment into such construction, all as required by the Contract Documents.

49. *Work Change Directive*--A written statement to CONTRACTOR issued on or after the Effective Date of the Agreement and signed by OWNER and recommended by ENGINEER ordering an addition, deletion, or revision in the Work, or responding to differing or unforeseen subsurface or physical conditions under which the Work is to be performed or to emergencies. A Work Change Directive will not change the Contract Price or the Contract Times but is evidence that the parties expect that the change ordered or documented by a Work Change Directive will be incorporated in a subsequently issued Change Order following negotiations by the parties as to its effect, if any, on the Contract Price or Contract Times.

50. *Written Amendment*--A written statement modifying the Contract Documents, signed by OWNER and CONTRACTOR on or after the Effective Date of the Agreement and normally dealing with the nonengineering or nontechnical rather than strictly construction-related aspects of the Contract Documents.

1.02 *Terminology*

A. *Intent of Certain Terms or Adjectives*

1. Whenever in the Contract Documents the terms "as allowed," "as approved," or terms of like effect or import are used, or the adjectives "reasonable," "suitable," "acceptable," "proper," "satisfactory," or adjectives of like effect or import are used to describe an action or determination of ENGINEER as to the Work, it is intended that such action or determination will be solely to evaluate, in general, the completed Work for compliance with the requirements of and information in the Contract Documents and conformance with the design concept of the completed Project as a functioning whole as shown or indicated in the Contract Documents (unless there is a specific statement indicating otherwise). The use of any such term or adjective shall not be effective to assign to ENGINEER any duty or authority to supervise or direct the performance of the Work or any duty or authority to undertake responsibility contrary to the provisions of paragraph 9.10 or any other provision of the Contract Documents.

B. *Day*

1. The word "day" shall constitute a calendar day of 24 hours measured from midnight to the next midnight.

C. *Defective*

1. The word "defective," when modifying the word "Work," refers to Work that is unsatisfactory, faulty, or deficient in that it does not conform to the Contract Documents or does not meet the requirements of any inspection, reference standard, test, or approval referred to in the Contract Documents, or has been damaged prior to ENGINEER's recommendation of final payment (unless responsibility for the protection thereof has been assumed by OWNER at Substantial Completion in accordance with paragraph 14.04 or 14.05).

D. *Furnish, Install, Perform, Provide*

1. The word "furnish," when used in connection with services, materials, or equipment, shall mean to supply and deliver said services, materials, or equipment to the Site (or some other

specified location) ready for use or installation and in usable or operable condition.

2. The word "install," when used in connection with services, materials, or equipment, shall mean to put into use or place in final position said services, materials, or equipment complete and ready for intended use.

3. The words "perform" or "provide," when used in connection with services, materials, or equipment, shall mean to furnish and install said services, materials, or equipment complete and ready for intended use.

4. When "furnish," "install," "perform," or "provide" is not used in connection with services, materials, or equipment in a context clearly requiring an obligation of CONTRACTOR, "provide" is implied.

E. Unless stated otherwise in the Contract Documents, words or phrases which have a well-known technical or construction industry or trade meaning are used in the Contract Documents in accordance with such recognized meaning.

ARTICLE 2 - PRELIMINARY MATTERS

---

2.01 *Delivery of Bonds*

A. When CONTRACTOR delivers the executed Agreements to OWNER, CONTRACTOR shall also deliver to OWNER such Bonds as CONTRACTOR may be required to furnish.

2.02\* *Copies of Documents*

A. OWNER shall furnish to CONTRACTOR up to ten copies of the Contract Documents. Additional copies will be furnished upon request at the cost of reproduction.

2.03 *Commencement of Contract Times; Notice to Proceed*

A. The Contract Times will commence to run on the thirtieth day after the Effective Date of the Agreement or, if a Notice to Proceed is given, on the day indicated in the Notice to Proceed. A Notice to Proceed may be given at any time within 30 days after the Effective Date of the Agreement. In no event will the Contract Times com-

mence to run later than the sixtieth day after the day of Bid opening or the thirtieth day after the Effective Date of the Agreement, whichever date is earlier.

#### 2.04 *Starting the Work*

A. CONTRACTOR shall start to perform the Work on the date when the Contract Times commence to run. No Work shall be done at the Site prior to the date on which the Contract Times commence to run.

\*See Supplementary Conditions

#### 2.05\* *Before Starting Construction*

A. *CONTRACTOR's Review of Contract Documents:* Before undertaking each part of the Work, CONTRACTOR shall carefully study and compare the Contract Documents and check and verify pertinent figures therein and all applicable field measurements. CONTRACTOR shall promptly report in writing to ENGINEER any conflict, error, ambiguity, or discrepancy which CONTRACTOR may discover and shall obtain a written interpretation or clarification from ENGINEER before proceeding with any Work affected thereby; however, CONTRACTOR shall not be liable to OWNER or ENGINEER for failure to report any conflict, error, ambiguity, or discrepancy in the Contract Documents unless CONTRACTOR knew or reasonably should have known thereof.

B. *Preliminary Schedules:* Within ten days after the Effective Date of the Agreement (unless otherwise specified in the General Requirements), CONTRACTOR shall submit to ENGINEER for its timely review:

1. a preliminary progress schedule indicating the times (numbers of days or dates) for starting and completing the various stages of the Work, including any Milestones specified in the Contract Documents;
2. a preliminary schedule of Shop Drawing and Sample submittals which will list each required submittal and the times for submitting, reviewing, and processing such submittal; and
3. a preliminary schedule of values for all of the Work which includes quantities and prices of items which when added together equal the Contract Price and subdivides the Work into

component parts in sufficient detail to serve as the basis for progress payments during performance of the Work. Such prices will include an appropriate amount of overhead and profit applicable to each item of Work.

\* C. *Evidence of Insurance:* Before any Work at the Site is started, CONTRACTOR and OWNER shall each deliver to the other, with copies to each additional insured identified in the Supplementary Conditions, certificates of insurance (and other evidence of insurance which either of them or any additional insured may reasonably request) which CONTRACTOR and OWNER respectively are required to purchase and maintain in accordance with Article 5.

#### 2.06 *Preconstruction Conference*

A. Within 20 days after the Contract Times start to run, but before any Work at the Site is started, a conference attended by CONTRACTOR, ENGINEER, and others as appropriate will be held to establish a working understanding among the parties as to the Work and to discuss the schedules referred to in paragraph 2.05.B, procedures for handling Shop Drawings and other submittals, processing Applications for Payment, and maintaining required records.

#### 2.07 *Initial Acceptance of Schedules*

A. Unless otherwise provided in the Contract Documents, at least ten days before submission of the first Application for Payment a conference attended by CONTRACTOR, ENGINEER, and others as appropriate will be held to review for acceptability to ENGINEER as provided below the schedules submitted in accordance with paragraph 2.05.B. CONTRACTOR shall have an additional ten days to make corrections and adjustments and to complete and resubmit the schedules. No progress payment shall be made to CONTRACTOR until acceptable schedules are submitted to ENGINEER.

1. The progress schedule will be acceptable to ENGINEER if it provides an orderly progression of the Work to completion within any specified Milestones and the Contract Times. Such acceptance will not impose on ENGINEER responsibility for the progress schedule, for sequencing, scheduling, or progress of the Work nor interfere with or relieve CONTRACTOR from CONTRACTOR's full responsibility therefor.

2. CONTRACTOR's schedule of Shop Drawing and Sample submittals will be acceptable to ENGINEER if it provides a workable arrangement for reviewing and processing the required submittals.

3. CONTRACTOR's schedule of values will be acceptable to ENGINEER as to form and substance if it provides a reasonable allocation of the Contract Price to component parts of the Work.

\*See Supplementary Conditions

### ARTICLE 3 - CONTRACT DOCUMENTS: INTENT, AMENDING, REUSE

#### 3.01\* *Intent*

A. The Contract Documents are complementary; what is called for by one is as binding as if called for by all.

B. It is the intent of the Contract Documents to describe a functionally complete Project (or part thereof) to be constructed in accordance with the Contract Documents. Any labor, documentation, services, materials, or equipment that may reasonably be inferred from the Contract Documents or from prevailing custom or trade usage as being required to produce the intended result will be provided whether or not specifically called for at no additional cost to OWNER.

C. Clarifications and interpretations of the Contract Documents shall be issued by ENGINEER as provided in Article 9.

#### 3.02 *Reference Standards*

##### A. *Standards, Specifications, Codes, Laws, and Regulations*

1. Reference to standards, specifications, manuals, or codes of any technical society, organization, or association, or to Laws or Regulations, whether such reference be specific or by implication, shall mean the standard, specification, manual, code, or Laws or Regulations in effect at the time of opening of Bids (or on the Effective Date of the Agreement if there were no Bids), except as may be otherwise specifically stated in the Contract Documents.

2. No provision of any such standard, specification, manual or code, or any instruction of a Supplier shall be effective to change the duties or responsibilities of OWNER, CONTRACTOR, or ENGINEER, or any of their subcontractors, consultants, agents, or employees from those set forth in the Contract Documents, nor shall any such provision or instruction be effective to assign to OWNER, ENGINEER, or any of ENGINEER's Consultants, agents, or employees any duty or authority to supervise or direct the performance of the Work or any duty or authority to undertake responsibility inconsistent with the provisions of the Contract Documents.

#### 3.03 *Reporting and Resolving Discrepancies*

##### A. *Reporting Discrepancies*

1. If, during the performance of the Work, CONTRACTOR discovers any conflict, error, ambiguity, or discrepancy within the Contract Documents or between the Contract Documents and any provision of any Law or Regulation applicable to the performance of the Work or of any standard, specification, manual or code, or of any instruction of any Supplier, CONTRACTOR shall report it to ENGINEER in writing at once. CONTRACTOR shall not proceed with the Work affected thereby (except in an emergency as required by paragraph 6.16.A) until an amendment or supplement to the Contract Documents has been issued by one of the methods indicated in paragraph 3.04; provided, however, that CONTRACTOR shall not be liable to OWNER or ENGINEER for failure to report any such conflict, error, ambiguity, or discrepancy unless CONTRACTOR knew or reasonably should have known thereof.

##### B. *Resolving Discrepancies*

1. Except as may be otherwise specifically stated in the Contract Documents, the provisions of the Contract Documents shall take precedence in resolving any conflict, error, ambiguity, or discrepancy between the provisions of the Contract Documents and:

a. the provisions of any standard, specification, manual, code, or instruction (whether or not specifically incorporated by reference in the Contract Documents); or

b. the provisions of any Laws or Regulations applicable to the performance of the Work (unless such an interpretation of the provisions of the Contract Documents would result in violation of such Law or Regulation).

### 3.04 *Amending and Supplementing Contract Documents*

A. The Contract Documents may be amended to provide for additions, deletions, and revisions in the Work or to modify the terms and conditions thereof in one or

\*See Supplementary Conditions

B. The requirements of the Contract Documents may be supplemented, and minor variations and deviations in the Work may be authorized, by one or more of the following ways: (i) a Field Order; (ii) ENGINEER's approval of a Shop Drawing or Sample; or (iii) ENGINEER's written interpretation or clarification.

### 3.05 *Reuse of Documents*

A. CONTRACTOR and any Subcontractor or Supplier or other individual or entity performing or furnishing any of the Work under a direct or indirect contract with OWNER: (i) shall not have or acquire any title to or ownership rights in any of the Drawings, Specifications, or other documents (or copies of any thereof) prepared by or bearing the seal of ENGINEER or ENGINEER's Consultant, including electronic media editions; and (ii) shall not reuse any of such Drawings, Specifications, other documents, or copies thereof on extensions of the Project or any other project without written consent of OWNER and ENGINEER and specific written verification or adaption by ENGINEER. This prohibition will survive final payment, completion, and acceptance of the Work, or termination or completion of the Contract. Nothing herein shall preclude CONTRACTOR from retaining copies of the Contract Documents for record purposes.

## ARTICLE 4 - AVAILABILITY OF LANDS; SUBSURFACE AND PHYSICAL CONDITIONS; REFERENCE POINTS

### 4.01 *Availability of Lands*

A. OWNER shall furnish the Site. OWNER shall notify CONTRACTOR of any encumbrances or

restrictions not of general application but specifically related to use of the Site with which CONTRACTOR must comply in performing the Work. OWNER will obtain in a timely manner and pay for easements for permanent structures or permanent changes in existing facilities. If CONTRACTOR and OWNER are unable to agree on entitlement to or on the amount or extent, if any, of any adjustment in the Contract Price or Contract Times, or both, as a result of any delay in OWNER's furnishing the Site, CONTRACTOR may make a Claim therefor as provided in paragraph 10.05.

B. Upon reasonable written request, OWNER shall furnish CONTRACTOR with a current statement of record legal title and legal description of the lands upon which the Work is to be performed and OWNER's interest therein as necessary for giving notice of or filing a mechanic's or construction lien against such lands in accordance with applicable Laws and Regulations.

C. CONTRACTOR shall provide for all additional lands and access thereto that may be required for temporary construction facilities or storage of materials and equipment.

### 4.02\* *Subsurface and Physical Conditions*

A.\* *Reports and Drawings:* The Supplementary Conditions identify:

1. those reports of explorations and tests of subsurface conditions at or contiguous to the Site that ENGINEER has used in preparing the Contract Documents; and
2. those drawings of physical conditions in or relating to existing surface or subsurface structures at or contiguous to the Site (except Underground Facilities) that ENGINEER has used in preparing the Contract Documents.

B. *Limited Reliance by CONTRACTOR on Technical Data Authorized:* CONTRACTOR may rely upon the general accuracy of the "technical data" contained in such reports and drawings, but such reports and drawings are not Contract Documents. Such "technical data" is identified in the Supplementary Conditions. Except for such reliance on such "technical data," CONTRACTOR may not rely upon or make any Claim against OWNER, ENGINEER, or any of ENGINEER's Consultants with respect to:

1. the completeness of such reports and drawings for CONTRACTOR's purposes, includ-

ing, but not limited to, any aspects of the means, methods, techniques, sequences, and procedures of construction to be employed by CONTRACTOR, and safety precautions and programs incident thereto; or

2. other data, interpretations, opinions, and information contained in such reports or shown or indicated in such drawings; or

3. any CONTRACTOR interpretation of or conclusion drawn from any "technical data" or any such other data, interpretations, opinions, or information.

\*See Supplementary Conditions

#### 4.03 Differing Subsurface or Physical Conditions

A. *Notice:* If CONTRACTOR believes that any subsurface or physical condition at or contiguous to the Site that is uncovered or revealed either:

1. is of such a nature as to establish that any "technical data" on which CONTRACTOR is entitled to rely as provided in paragraph 4.02 is materially inaccurate; or

2. is of such a nature as to require a change in the Contract Documents; or

3. differs materially from that shown or indicated in the Contract Documents; or

4. is of an unusual nature, and differs materially from conditions ordinarily encountered and generally recognized as inherent in work of the character provided for in the Contract Documents; then CONTRACTOR shall, promptly after becoming aware thereof and before further disturbing the subsurface or physical conditions or performing any Work in connection therewith (except in an emergency as required by paragraph 6.16.A), notify OWNER and ENGINEER in writing about such condition. CONTRACTOR shall not further disturb such condition or perform any Work in connection therewith (except as aforesaid) until receipt of written order to do so.

B. *ENGINEER's Review:* After receipt of written notice as required by paragraph 4.03.A, ENGINEER will promptly review the pertinent condition, determine the

necessity of OWNER's obtaining additional exploration or tests with respect thereto, and advise OWNER in writing (with a copy to CONTRACTOR) of ENGINEER's findings and conclusions.

#### C. Possible Price and Times Adjustments

1. The Contract Price or the Contract Times, or both, will be equitably adjusted to the extent that the existence of such differing subsurface or physical condition causes an increase or decrease in CONTRACTOR's cost of, or time required for, performance of the Work; subject, however, to the following:

a. such condition must meet any one or more of the categories described in paragraph 4.03.A; and

b. with respect to Work that is paid for on a Unit Price Basis, any adjustment in Contract Price will be subject to the provisions of paragraphs 9.08 and 11.03.

2. CONTRACTOR shall not be entitled to any adjustment in the Contract Price or Contract Times if:

a. CONTRACTOR knew of the existence of such conditions at the time CONTRACTOR made a final commitment to OWNER in respect of Contract Price and Contract Times by the submission of a Bid or becoming bound under a negotiated contract; or

b. the existence of such condition could reasonably have been discovered or revealed as a result of any examination, investigation, exploration, test, or study of the Site and contiguous areas required by the Bidding Requirements or Contract Documents to be conducted by or for CONTRACTOR prior to CONTRACTOR's making such final commitment; or

c. CONTRACTOR failed to give the written notice within the time and as required by paragraph 4.03.A.

3. If OWNER and CONTRACTOR are unable to agree on entitlement to or on the amount or extent, if any, of any adjustment in the Contract Price or Contract Times, or both, a Claim may be

made therefor as provided in paragraph 10.05. However, OWNER, ENGINEER, and ENGINEER's Consultants shall not be liable to CONTRACTOR for any claims, costs, losses, or damages (including but not limited to all fees and charges of engineers, architects, attorneys, and other professionals and all court or arbitration or other dispute resolution costs) sustained by CONTRACTOR on or in connection with any other project or anticipated project.

#### 4.04 *Underground Facilities*

A. *Shown or Indicated:* The information and data shown or indicated in the Contract Documents with respect to existing Underground Facilities at or contiguous to the Site is based on information and data furnished to OWNER or ENGINEER by the owners of such Underground Facilities, including OWNER, or by others. Unless it is otherwise expressly provided in the Supplementary Conditions:

1. OWNER and ENGINEER shall not be responsible for the accuracy or completeness of any such information or data; and

2. the cost of all of the following will be included in the Contract Price, and CONTRACTOR shall have full responsibility for:

a. reviewing and checking all such information and data,

b. locating all Underground Facilities shown or indicated in the Contract Documents,

c. coordination of the Work with the owners of such Underground Facilities, including OWNER, during construction, and

d. the safety and protection of all such Underground Facilities and repairing any damage thereto resulting from the Work.

#### B. *Not Shown or Indicated*

1. If an Underground Facility is uncovered or revealed at or contiguous to the Site which was not shown or indicated, or not shown or indicated with reasonable accuracy in the Contract Documents, CONTRACTOR shall, promptly after becoming aware thereof and before further disturbing conditions affected thereby or

performing any Work in connection therewith (except in an emergency as required by paragraph 6.16.A), identify the owner of such Underground Facility and give written notice to that owner and to OWNER and ENGINEER. ENGINEER will promptly review the Underground Facility and determine the extent, if any, to which a change is required in the Contract Documents to reflect and document the consequences of the existence or location of the Underground Facility. During such time, CONTRACTOR shall be responsible for the safety and protection of such Underground Facility.

2. If ENGINEER concludes that a change in the Contract Documents is required, a Work Change Directive or a Change Order will be issued to reflect and document such consequences. An equitable adjustment shall be made in the Contract Price of Contract Times, or both, to the extent that they are attributable to the existence or location of any Underground Facility that was not shown or indicated or not shown or indicated with reasonable accuracy in the Contract Documents and that CONTRACTOR did not know of and could not reasonably have been expected to be aware of or to have anticipated. If OWNER and CONTRACTOR are unable to agree on entitlement to or on the amount or extent, if any, of any such adjustment in Contract Price or Contract Times, OWNER or CONTRACTOR may make a Claim therefor as provided in paragraph 10.05.

#### 4.05\* *Reference Points*

A. OWNER shall provide engineering surveys to establish reference points for construction which in ENGINEER's judgment are necessary to enable CONTRACTOR to proceed with the Work. CONTRACTOR shall be responsible for laying out the Work, shall protect and preserve the established reference points and property monuments, and shall make no changes or relocations without the prior written approval of OWNER. CONTRACTOR shall report to ENGINEER whenever any reference point or property monument is lost or destroyed or requires relocation because of necessary changes in grades or locations, and shall be responsible for the accurate replacement or relocation of such reference points or property monuments by professionally qualified personnel.

#### 4.06 *Hazardous Environmental Condition at Site*

A. *Reports and Drawings*: Reference is made to the Supplementary Conditions for the identification of those reports and drawings relating to a Hazardous Environmental Condition identified at the Site, if any, that have been utilized by the ENGINEER in the preparation of the Contract Documents.

B. *Limited Reliance by CONTRACTOR on Technical Data Authorized*: CONTRACTOR may rely upon the general accuracy of the "technical data" contained in such reports and drawings, but such reports and drawings are not Contract Documents. Such "technical data" is identified in the Supplementary Conditions. Except for such reliance on such "technical data," CONTRACTOR may not rely upon or make any Claim against OWNER, ENGINEER or any of ENGINEER's Consultants with respect to:

1. the completeness of such reports and drawings for CONTRACTOR's purposes, including, but not limited to, any aspects of the means, methods, techniques, sequences and procedures of construction to be employed by CONTRACTOR and safety precautions and programs incident thereto; or

\*See Supplementary Conditions

2. other data, interpretations, opinions and information contained in such reports or shown or indicated in such drawings; or

3. any CONTRACTOR interpretation of or conclusion drawn from any "technical data" or any such other data, interpretations, opinions or information.

C. CONTRACTOR shall not be responsible for any Hazardous Environmental Condition uncovered or revealed at the Site which was not shown or indicated in Drawings or Specifications or identified in the Contract Documents to be within the scope of the Work. CONTRACTOR shall be responsible for a Hazardous Environmental Condition created with any materials brought to the Site by CONTRACTOR, Subcontractors, Suppliers, or anyone else for whom CONTRACTOR is responsible.

D. If CONTRACTOR encounters a Hazardous Environmental Condition or if CONTRACTOR or anyone for whom CONTRACTOR is responsible creates a Hazardous Environmental Condition, CONTRACTOR shall immediately: (i) secure or otherwise isolate such condition;

(ii) stop all Work in connection with such condition and in any area affected thereby (except in an emergency as required by paragraph 6.16); and (iii) notify OWNER and ENGINEER (and promptly thereafter confirm such notice in writing). OWNER shall promptly consult with ENGINEER concerning the necessity for OWNER to retain a qualified expert to evaluate such condition or take corrective action, if any.

E. CONTRACTOR shall not be required to resume Work in connection with such condition or in any affected area until after OWNER has obtained any required permits related thereto and delivered to CONTRACTOR written notice: (i) specifying that such condition and any affected area is or has been rendered safe for the resumption of Work; or (ii) specifying any special conditions under which such Work may be resumed safely. If OWNER and CONTRACTOR cannot agree as to entitlement to or on the amount or extent, if any, of any adjustment in Contract Price or Contract Times, or both, as a result of such Work stoppage or such special conditions under which Work is agreed to be resumed by CONTRACTOR, either party may make a Claim therefor as provided in paragraph 10.05.

F. If after receipt of such written notice CONTRACTOR does not agree to resume such Work based on a reasonable belief it is unsafe, or does not agree to resume such Work under such special conditions, then OWNER may order the portion of the Work that is in the area affected by such condition to be deleted from the Work. If OWNER and CONTRACTOR cannot agree as to entitlement to or on the amount or extent, if any, of an adjustment in Contract Price or Contract Times as a result of deleting such portion of the Work, then either party may make a Claim therefor as provided in paragraph 10.05.

OWNER may have such deleted portion of the Work performed by OWNER's own forces or others in accordance with Article 7.

G. To the fullest extent permitted by Laws and Regulations, OWNER shall indemnify and hold harmless CONTRACTOR, Subcontractors, ENGINEER, ENGINEER's Consultants and the officers, directors, partners, employees, agents, other consultants, and subcontractors of each and any of them from and against all claims, costs, losses, and damages (including but not limited to all fees and charges of engineers, architects, attorneys, and other professionals and all court or arbitration or other dispute resolution costs) arising out of or relating to a Hazardous Environmental Condition, provided that such Hazardous Environmental Condition: (i) was not shown or indicated in the Drawings or

Specifications or identified in the Contract Documents to be included within the scope of the Work, and (ii) was not created by CONTRACTOR or by anyone for whom CONTRACTOR is responsible. Nothing in this paragraph 4.06.E shall obligate OWNER to indemnify any individual or entity from and against the consequences of that individual's or entity's own negligence.

H. To the fullest extent permitted by Laws and Regulations, CONTRACTOR shall indemnify and hold harmless OWNER, ENGINEER, ENGINEER's Consultants, and the officers, directors, partners, employees, agents, other consultants, and subcontractors of each and any of them from and against all claims, costs, losses, and damages (including but not limited to all fees and charges of engineers, architects, attorneys, and other professionals and all court or arbitration or other dispute resolution costs) arising out of or relating to a Hazardous Environmental Condition created by CONTRACTOR or by anyone for whom CONTRACTOR is responsible. Nothing in this paragraph 4.06.F shall obligate CONTRACTOR to indemnify any individual or entity from and against the consequences of that individual's or entity's own negligence.

I. The provisions of paragraphs 4.02, 4.03, and 4.04 are not intended to apply to a Hazardous Environmental Condition uncovered or revealed at the Site.

\*See Supplementary Conditions

## ARTICLE 5 - BONDS AND INSURANCE

### 5.01\* *Performance, Payment, and Other Bonds*

A. CONTRACTOR shall furnish performance and payment Bonds, each in an amount at least equal to the Contract Price as security for the faithful performance and payment of all CONTRACTOR's obligations under the Contract Documents. These Bonds shall remain in effect at least until one year after the date when final payment becomes due, except as provided otherwise by Laws or Regulations or by the Contract Documents. CONTRACTOR shall also furnish such other Bonds as are required by the Contract Documents.

B.\* All Bonds shall be in the form prescribed by the Contract Documents except as provided otherwise by Laws or Regulations, and shall be executed by such sureties as are named in the current list of "Companies Holding Certificates of Authority as Acceptable Sureties on Federal Bonds and as Acceptable Reinsuring Compa-

nies" as published in Circular 570 (amended) by the Financial Management Service, Surety Bond Branch, U.S. Department of the Treasury. All Bonds signed by an agent must be accompanied by a certified copy of such agent's authority to act.

C. If the surety on any Bond furnished by CONTRACTOR is declared bankrupt or becomes insolvent or its right to do business is terminated in any state where any part of the Project is located or it ceases to meet the requirements of paragraph 5.01.B, CONTRACTOR shall within 20 days thereafter substitute another Bond and surety, both of which shall comply with the requirements of paragraphs 5.01.B and 5.02.

### 5.02 *Licensed Sureties and Insurers*

A. All Bonds and insurance required by the Contract Documents to be purchased and maintained by OWNER or CONTRACTOR shall be obtained from surety or insurance companies that are duly licensed or authorized in the jurisdiction in which the Project is located to issue Bonds or insurance policies for the limits and coverages so required. Such surety and insurance companies shall also meet such additional requirements and qualifications as may be provided in the Supplementary Conditions.

### 5.03 *Certificates of Insurance*

A. CONTRACTOR shall deliver to OWNER, with copies to each additional insured identified in the Supplementary Conditions, certificates of insurance (and other evidence of insurance requested by OWNER or any other additional insured) which CONTRACTOR is required to purchase and maintain. OWNER shall deliver to CONTRACTOR, with copies to each additional insured identified in the Supplementary Conditions, certificates of insurance (and other evidence of insurance requested by CONTRACTOR or any other additional insured) which OWNER is required to purchase and maintain.

### 5.04\* *CONTRACTOR's Liability Insurance*

A. CONTRACTOR shall purchase and maintain such liability and other insurance as is appropriate for the Work being performed and as will provide protection from claims set forth below which may arise out of or result from CONTRACTOR's performance of the Work and CONTRACTOR's other obligations under the Contract Documents, whether it is to be performed by CONTRACTOR, any Subcontractor or Supplier, or by anyone directly or indirectly employed by any of them to

perform any of the Work, or by anyone for whose acts any of them may be liable:

1. claims under workers' compensation, disability benefits, and other similar employee benefit acts;
2. claims for damages because of bodily injury, occupational sickness or disease, or death of CONTRACTOR's employees;
3. claims for damages because of bodily injury, sickness or disease, or death of any person other than CONTRACTOR's employees;
4. claims for damages insured by reasonably available personal injury liability coverage which are sustained: (i) by any person as a result of an offense directly or indirectly related to the employment of such person by CONTRACTOR, or (ii) by any other person for any other reason;
5. claims for damages, other than to the Work itself, because of injury to or destruction of tangible property wherever located, including loss of use resulting therefrom; and
6. claims for damages because of bodily injury or death of any person or property damage arising out of the ownership, maintenance or use of any motor vehicle.

B. The policies of insurance so required by this paragraph 5.04 to be purchased and maintained shall:

\*See Supplementary Conditions

1. with respect to insurance required by paragraphs 5.04.A.3 through 5.04.A.6 inclusive, include as additional insureds (subject to any customary exclusion in respect of professional liability) OWNER, ENGINEER, ENGINEER'S Consultants, and any other individuals or entities identified in the Supplementary Conditions, all of whom shall be listed as additional insureds, and include coverage for the respective officers, directors, partners, employees, agents, and other consultants and subcontractors of each and any of all such additional insureds, and the insurance afforded to these additional insureds shall provide primary coverage for all claims covered thereby;

2. include at least the specific coverages and be written for not less than the limits of liability provided in the Supplementary Conditions or required by Laws or Regulations, whichever is greater;

3. include completed operations insurance;

4. include contractual liability insurance covering CONTRACTOR's indemnity obligations under paragraphs 6.07, 6.11, and 6.20;

5. contain a provision or endorsement that the coverage afforded will not be canceled, materially changed or renewal refused until at least thirty days prior written notice has been given to OWNER and CONTRACTOR and to each other additional insured identified in the Supplementary Conditions to whom a certificate of insurance has been issued (and the certificates of insurance furnished by the CONTRACTOR pursuant to paragraph 5.03 will so provide);

6. remain in effect at least until final payment and at all times thereafter when CONTRACTOR may be correcting, removing, or replacing defective Work in accordance with paragraph 13.07; and

7. with respect to completed operations insurance, and any insurance coverage written on a claims-made basis, remain in effect for at least two years after final payment (and CONTRACTOR shall furnish OWNER and each other additional insured identified in the Supplementary Conditions, to whom a certificate of insurance has been issued, evidence satisfactory to OWNER and any such additional insured of continuation of such insurance at final payment and one year thereafter).

#### 5.05 *OWNER's Liability Insurance*

A.\* In addition to the insurance required to be provided by CONTRACTOR under paragraph 5.04, OWNER, at OWNER's option, may purchase and maintain at OWNER's expense OWNER's own liability insurance as will protect OWNER against claims which may arise from operations under the Contract Documents.

#### 5.06\* *Property Insurance*

A. Unless otherwise provided in the Supplementary Conditions, OWNER shall purchase and maintain property

insurance upon the Work at the Site in the amount of the full replacement cost thereof (subject to such deductible amounts as may be provided in the Supplementary Conditions or required by Laws and Regulations). This insurance shall:

1. include the interests of OWNER, CONTRACTOR, Subcontractors, ENGINEER, ENGINEER's Consultants, and any other individuals or entities identified in the Supplementary Conditions, and the officers, directors, partners, employees, agents, and other consultants and subcontractors of each and any of them, each of whom is deemed to have an insurable interest and shall be listed as an additional insured;

2. be written on a Builder's Risk "all-risk" or open peril or special causes of loss policy form that shall at least include insurance for physical loss or damage to the Work, temporary buildings, false work, and materials and equipment in transit, and shall insure against at least the following perils or causes of loss: fire, lightning, extended coverage, theft, vandalism and malicious mischief, earthquake, collapse, debris removal, demolition occasioned by enforcement of Laws and Regulations, water damage, and such other perils or causes of loss as may be specifically required by the Supplementary Conditions;

3. include expenses incurred in the repair or replacement of any insured property (including but not limited to fees and charges of engineers and architects);

\*See Supplementary Conditions

4. cover materials and equipment stored at the Site or at another location that was agreed to in writing by OWNER prior to being incorporated in the Work, provided that such materials and equipment have been included in an Application for Payment recommended by ENGINEER;

5. allow for partial utilization of the Work by OWNER;

6. include testing and startup; and

7. be maintained in effect until final payment is made unless otherwise agreed to in writing by OWNER, CONTRACTOR, and ENGINEER with

30 days written notice to each other additional insured to whom a certificate of insurance has been issued.

B.\* OWNER shall purchase and maintain such boiler and machinery insurance or additional property insurance as may be required by the Supplementary Conditions or Laws and Regulations which will include the interests of OWNER, CONTRACTOR, Subcontractors, ENGINEER, ENGINEER's Consultants, and any other individuals or entities identified in the Supplementary Conditions, each of whom is deemed to have an insurable interest and shall be listed as an insured or additional insured.

C.\* All the policies of insurance (and the certificates or other evidence thereof) required to be purchased and maintained in accordance with paragraph 5.06 will contain a provision or endorsement that the coverage afforded will not be canceled or materially changed or renewal refused until at least 30 days prior written notice has been given to OWNER and CONTRACTOR and to each other additional insured to whom a certificate of insurance has been issued and will contain waiver provisions in accordance with paragraph 5.07.

D.\* OWNER shall not be responsible for purchasing and maintaining any property insurance specified in this paragraph 5.06 to protect the interests of CONTRACTOR, Subcontractors, or others in the Work to the extent of any deductible amounts that are identified in the Supplementary Conditions. The risk of loss within such identified deductible amount will be borne by CONTRACTOR, Subcontractors, or others suffering any such loss, and if any of them wishes property insurance coverage within the limits of such amounts, each may purchase and maintain it at the purchaser's own expense.

E.\* If CONTRACTOR requests in writing that other special insurance be included in the property insurance policies provided under paragraph 5.06, OWNER shall, if possible, include such insurance, and the cost thereof will be charged to CONTRACTOR by appropriate Change Order or Written Amendment. Prior to commencement of the Work at the Site, OWNER shall in writing advise CONTRACTOR whether or not such other insurance has been procured by OWNER.

#### 5.07 *Waiver of Rights*

A.\* OWNER and CONTRACTOR intend that all policies purchased in accordance with paragraph 5.06 will protect OWNER, CONTRACTOR, Subcontractors, ENGINEER, ENGINEER's Consultants, and all other

individuals or entities identified in the Supplementary Conditions to be listed as insureds or additional insureds (and the officers, directors, partners, employees, agents, and other consultants and subcontractors of each and any of them) in such policies and will provide primary coverage for all losses and damages caused by the perils or causes of loss covered thereby. All such policies shall contain provisions to the effect that in the event of payment of any loss or damage the insurers will have no rights of recovery against any of the insureds or additional insureds thereunder. OWNER and CONTRACTOR waive all rights against each other and their respective officers, directors, partners, employees, agents, and other consultants and subcontractors of each and any of them for all losses and damages caused by, arising out of or resulting from any of the perils or causes of loss covered by such policies and any other property insurance applicable to the Work; and, in addition, waive all such rights against Subcontractors, ENGINEER, ENGINEER's Consultants, and all other individuals or entities identified in the Supplementary Conditions to be listed as insureds or additional insureds (and the officers, directors, partners, employees, agents, and other consultants and subcontractors of each and any of them) under such policies for losses and damages so caused.

None of the above waivers shall extend to the rights that any party making such waiver may have to the proceeds of insurance held by OWNER as trustee or otherwise payable under any policy so issued.

B. OWNER waives all rights against CONTRACTOR, Subcontractors, ENGINEER, ENGINEER's Consultants, and the officers, directors, partners, employees, agents, and other consultants and subcontractors of each and any of them for:

\*See Supplementary Conditions

1. loss due to business interruption, loss of use, or other consequential loss extending beyond direct physical loss or damage to OWNER's property or the Work caused by, arising out of, or resulting from fire or other peril whether or not insured by OWNER; and

2. loss or damage to the completed Project or part thereof caused by, arising out of, or resulting from fire or other insured peril or cause of loss covered by any property insurance maintained on the completed Project or part thereof by OWNER during partial utilization pursuant to

paragraph 14.05, after Substantial Completion pursuant to paragraph 14.04, or after final payment pursuant to paragraph 14.07.

C. Any insurance policy maintained by OWNER covering any loss, damage or consequential loss referred to in paragraph 5.07.B shall contain provisions to the effect that in the event of payment of any such loss, damage, or consequential loss, the insurers will have no rights of recovery against CONTRACTOR, Subcontractors, ENGINEER, or ENGINEER's Consultants and the officers, directors, partners, employees, agents, and other consultants and subcontractors of each and any of them.

#### 5.08\* *Receipt and Application of Insurance Proceeds*

A.\* Any insured loss under the policies of insurance required by paragraph 5.06 will be adjusted with OWNER and made payable to OWNER as fiduciary for the insureds, as their interests may appear, subject to the requirements of any applicable mortgage clause and of paragraph 5.08.B. OWNER shall deposit in a separate account any money so received and shall distribute it in accordance with such agreement as the parties in interest may reach. If no other special agreement is reached, the damaged Work shall be repaired or replaced, the moneys so received applied on account thereof, and the Work and the cost thereof covered by an appropriate Change Order or Written Amendment.

B.\* OWNER as fiduciary shall have power to adjust and settle any loss with the insurers unless one of the parties in interest shall object in writing within 15 days after the occurrence of loss to OWNER's exercise of this power. If such objection be made, OWNER as fiduciary shall make settlement with the insurers in accordance with such agreement as the parties in interest may reach. If no such agreement among the parties in interest is reached, OWNER as fiduciary shall adjust and settle the loss with the insurers and, if required in writing by any party in interest, OWNER as fiduciary shall give bond for the proper performance of such duties.

#### 5.09\* *Acceptance of Bonds and Insurance; Option to Replace*

A.\* If either OWNER or CONTRACTOR has any objection to the coverage afforded by or other provisions of the Bonds or insurance required to be purchased and maintained by the other party in accordance with Article 5 on the basis of non-conformance with the Contract Documents, the objecting party shall so notify the other party in writing within 10 days after receipt of the

certificates (or other evidence requested) required by paragraph 2.05.C. OWNER and CONTRACTOR shall each provide to the other such additional information in respect of insurance provided as the other may reasonably request. If either party does not purchase or maintain all of the Bonds and insurance required of such party by the Contract Documents, such party shall notify the other party in writing of such failure to purchase prior to the start of the Work, or of such failure to maintain prior to any change in the required coverage. Without prejudice to any other right or remedy, the other party may elect to obtain equivalent Bonds or insurance to protect such other party's interests at the expense of the party who was required to provide such coverage, and a Change Order shall be issued to adjust the Contract Price accordingly.

#### 5.10 *Partial Utilization, Acknowledgment of Property Insurer*

A. If OWNER finds it necessary to occupy or use a portion or portions of the Work prior to Substantial Completion of all the Work as provided in paragraph 14.05, no such use or occupancy shall commence before the insurers providing the property insurance pursuant to paragraph 5.06 have acknowledged notice thereof and in writing effected any changes in coverage necessitated thereby. The insurers providing the property insurance shall consent by endorsement on the policy or policies, but the property insurance shall not be canceled or permitted to lapse on account of any such partial use or occupancy.

### ARTICLE 6 - CONTRACTOR'S RESPONSIBILITIES

---

#### 6.01 *Supervision and Superintendence*

A. CONTRACTOR shall supervise, inspect, and direct the Work competently and efficiently, devoting such attention thereto and applying such skills and expertise as may be necessary to perform the Work in accordance with

\*See Supplementary Conditions

the Contract Documents. CONTRACTOR shall be solely responsible for the means, methods, techniques, sequences, and procedures of construction, but CONTRACTOR shall not be responsible for the negligence of OWNER or ENGINEER in the design or specification of a specific means, method, technique, sequence, or procedure of

construction which is shown or indicated in and expressly required by the Contract Documents. CONTRACTOR shall be responsible to see that the completed Work complies accurately with the Contract Documents.

B. At all times during the progress of the Work, CONTRACTOR shall assign a competent resident superintendent thereto who shall not be replaced without written notice to OWNER and ENGINEER except under extraordinary circumstances. The superintendent will be CONTRACTOR's representative at the Site and shall have authority to act on behalf of CONTRACTOR. All communications given to or received from the superintendent shall be binding on CONTRACTOR.

#### 6.02 *Labor; Working Hours*

A. CONTRACTOR shall provide competent, suitably qualified personnel to survey, lay out, and construct the

Work as required by the Contract Documents. CONTRACTOR shall at all times maintain good discipline and order at the Site.

B. Except as otherwise required for the safety or protection of persons or the Work or property at the Site or adjacent thereto, and except as otherwise stated in the Contract Documents, all Work at the Site shall be performed during regular working hours, and CONTRACTOR will not permit overtime work or the performance of Work on Saturday, Sunday, or any legal holiday without OWNER's written consent (which will not be unreasonably withheld) given after prior written notice to ENGINEER.

#### 6.03 *Services, Materials, and Equipment*

A. Unless otherwise specified in the General Requirements, CONTRACTOR shall provide and assume full responsibility for all services, materials, equipment, labor, transportation, construction equipment and machinery, tools, appliances, fuel, power, light, heat, telephone, water, sanitary facilities, temporary facilities, and all other facilities and incidentals necessary for the performance, testing, start-up, and completion of the Work.

B. All materials and equipment incorporated into the Work shall be as specified or, if not specified, shall be of good quality and new, except as otherwise provided in the Contract Documents. All warranties and guarantees specifically called for by the Specifications shall expressly

run to the benefit of OWNER. If required by ENGINEER, CONTRACTOR shall furnish satisfactory evidence (including reports of required tests) as to the source, kind, and quality of materials and equipment. All materials and equipment shall be stored, applied, installed, connected, erected, protected, used, cleaned, and conditioned in accordance with instructions of the applicable Supplier, except as otherwise may be provided in the Contract Documents.

#### 6.04 *Progress Schedule*

A. CONTRACTOR shall adhere to the progress schedule established in accordance with paragraph 2.07 as it may be adjusted from time to time as provided below.

1. CONTRACTOR shall submit to ENGINEER for acceptance (to the extent indicated in paragraph 2.07) proposed adjustments in the progress schedule that will not result in changing the Contract Times (or Milestones). Such adjustments will conform generally to the progress schedule then in effect and additionally will comply with any provisions of the General Requirements applicable thereto.

2. Proposed adjustments in the progress schedule that will change the Contract Times (or Milestones) shall be submitted in accordance with the requirements of Article 12. Such adjustments may only be made by a Change Order or Written Amendment in accordance with Article 12.

#### 6.05 *Substitutes and "Or-Equals"*

A. Whenever an item of material or equipment is specified or described in the Contract Documents by using the name of a proprietary item or the name of a particular Supplier, the specification or description is intended to establish the type, function, appearance, and quality required. Unless the specification or description contains or is followed by words reading that no like, equivalent, or "or-equal" item or no substitution is permitted, other items of material or equipment or material or equipment of other Suppliers may be submitted to ENGINEER for review under the circumstances described below.

1. *"Or-Equal" Items:* If in ENGINEER's sole discretion an item of material or equipment proposed by CONTRACTOR is functionally equal to that named and sufficiently similar so that no change in related Work will be required, it may be

considered by ENGINEER as an "or-equal" item, in which case review and approval of the proposed item may, in ENGINEER's sole discretion, be accomplished without compliance with some or all of the requirements for approval of proposed substitute items. For the purposes of this paragraph 6.05.A.1, a proposed item of material or equipment will be considered functionally equal to an item so named if:

a. in the exercise of reasonable judgment ENGINEER determines that: (i) it is at least equal in quality, durability, appearance, strength, and design characteristics; (ii) it will reliably perform at least equally well the function imposed by the design concept of the completed Project as a functioning whole, and;

b. CONTRACTOR certifies that: (i) there is no increase in cost to the OWNER; and (ii) it will conform substantially, even with deviations, to the detailed requirements of the item named in the Contract Documents.

#### 2. *Substitute Items*

a. If in ENGINEER's sole discretion an item of material or equipment proposed by CONTRACTOR does not qualify as an "or-equal" item under paragraph 6.05.A.1, it will be considered a proposed substitute item.

b. CONTRACTOR shall submit sufficient information as provided below to allow ENGINEER to determine that the item of material or equipment proposed is essentially equivalent to that named and an acceptable substitute therefor. Requests for review of proposed substitute items of material or equipment will not be accepted by ENGINEER from anyone other than CONTRACTOR.

c. The procedure for review by ENGINEER will be as set forth in paragraph 6.05.A.2.d, as supplemented in the General Requirements and as ENGINEER may decide is appropriate under the circumstances.

d. CONTRACTOR shall first make written application to ENGINEER for review of a proposed substitute item of material or equipment that CONTRACTOR seeks to furnish or use. The application shall certify

that the proposed substitute item will perform adequately the functions and achieve the results called for by the general design, be similar in substance to that specified, and be suited to the same use as that specified. The application will state the extent, if any, to which the use of the proposed substitute item will prejudice CONTRACTOR's achievement of Substantial Completion on time, whether or not use of the proposed substitute item in the Work will require a change in any of the Contract Documents (or in the provisions of any other direct contract with OWNER for work on the Project) to adapt the design to the proposed substitute item and whether or not incorporation or use of the proposed substitute item in connection with the Work is subject to payment of any license fee or royalty. All variations of the proposed substitute item from that specified will be identified in the application, and available engineering, sales, maintenance, repair, and replacement services will be indicated. The application will also contain an itemized estimate of all costs or credits that will result directly or indirectly from use of such substitute item, including costs of redesign and claims of other contractors affected by any resulting change, all of which will be considered by ENGINEER in evaluating the proposed substitute item. ENGINEER may require CONTRACTOR to furnish additional data about the proposed substitute item.

**B. *Substitute Construction Methods or Procedures:***

If a specific means, method, technique, sequence, or procedure of construction is shown or indicated in and expressly required by the Contract Documents, CONTRACTOR may furnish or utilize a substitute means, method, technique, sequence, or procedure of construction approved by ENGINEER. CONTRACTOR shall submit sufficient information to allow ENGINEER, in ENGINEER's sole discretion, to determine that the substitute proposed is equivalent to that expressly called for by the Contract Documents. The procedure for review by ENGINEER will be similar to that provided in subparagraph 6.05.A.2.

**C. *Engineer's Evaluation:*** ENGINEER will be allowed a reasonable time within which to evaluate each proposal or submittal made pursuant to paragraphs 6.05.A and 6.05.B. ENGINEER will be the sole judge of acceptability. No "or-equal" or substitute will be ordered, installed or utilized until ENGINEER's review is complete, which will be evidenced by either a Change Order for a

substitute or an approved Shop Drawing for an "or equal." ENGINEER will advise CONTRACTOR in writing of any negative determination.

**D. *Special Guarantee:*** OWNER may require CONTRACTOR to furnish at CONTRACTOR's expense a special performance guarantee or other surety with respect to any substitute.

**E. *ENGINEER's Cost Reimbursement:*** ENGINEER will record time required by ENGINEER and ENGINEER's Consultants in evaluating substitute proposed or submitted by CONTRACTOR pursuant to paragraphs 6.05.A.2 and 6.05.B and in making changes in the Contract Documents (or in the provisions of any other direct contract with OWNER for work on the Project) occasioned thereby. Whether or not ENGINEER approves a substitute item so proposed or submitted by CONTRACTOR, CONTRACTOR shall reimburse OWNER for the charges of ENGINEER and ENGINEER's Consultants for evaluating each such proposed substitute.

**F. *CONTRACTOR's Expense:*** CONTRACTOR shall provide all data in support of any proposed substitute or "or-equal" at CONTRACTOR's expense.

**6.06 *Concerning Subcontractors, Suppliers, and Others***

**A.** CONTRACTOR shall not employ any Subcontractor, Supplier, or other individual or entity (including those acceptable to OWNER as indicated in paragraph 6.06.B), whether initially or as a replacement, against whom OWNER may have reasonable objection. CONTRACTOR shall not be required to employ any Subcontractor, Supplier, or other individual or entity to furnish or perform any of the Work against whom CONTRACTOR has reasonable objection.

**B.** If the Supplementary Conditions require the identity of certain Subcontractors, Suppliers, or other individuals or entities to be submitted to OWNER in advance for acceptance by OWNER by a specified date prior to the Effective Date of the Agreement, and if CONTRACTOR has submitted a list thereof in accordance with the Supplementary Conditions, OWNER's acceptance (either in writing or by failing to make written objection thereto by the date indicated for acceptance or objection in the Bidding Documents or the Contract Documents) of any such Subcontractor, Supplier, or other individual or entity so identified may be revoked on the basis of reasonable objection after due investigation. CONTRACTOR shall submit an acceptable replacement

for the rejected Subcontractor, Supplier, or other individual or entity, and the Contract Price will be adjusted by the difference in the cost occasioned by such replacement, and an appropriate Change Order will be issued or Written Amendment signed. No acceptance by OWNER of any such Subcontractor, Supplier, or other individual or entity, whether initially or as a replacement, shall constitute a waiver of any right of OWNER or ENGINEER to reject defective Work.

C. CONTRACTOR shall be fully responsible to OWNER and ENGINEER for all acts and omissions of the Subcontractors, Suppliers, and other individuals or entities performing or furnishing any of the Work just as CONTRACTOR is responsible for CONTRACTOR's own acts and omissions. Nothing in the Contract Documents shall create for the benefit of any such Subcontractor, Supplier, or other individual or entity any contractual relationship between OWNER or ENGINEER and any such Subcontractor, Supplier or other individual or entity, nor shall it create any obligation on the part of OWNER or ENGINEER to pay or to see to the payment of any moneys due any such Subcontractor, Supplier, or other individual or entity except as may otherwise be required by Laws and Regulations.

D. CONTRACTOR shall be solely responsible for scheduling and coordinating the Work of Subcontractors, Suppliers, and other individuals or entities performing or furnishing any of the Work under a direct or indirect contract with CONTRACTOR.

E. CONTRACTOR shall require all Subcontractors, Suppliers, and such other individuals or entities performing or furnishing any of the Work to communicate with ENGINEER through CONTRACTOR.

F. The divisions and sections of the Specifications and the identifications of any Drawings shall not control CONTRACTOR in dividing the Work among Subcontractors or Suppliers or delineating the Work to be performed by any specific trade.

G. All Work performed for CONTRACTOR by a Subcontractor or Supplier will be pursuant to an appropriate agreement between CONTRACTOR and the Subcontractor or Supplier which specifically binds the Subcontractor or Supplier to the applicable terms and conditions of the Contract Documents for the benefit of OWNER and ENGINEER. Whenever any such agreement is with a Subcontractor or Supplier who is listed as an additional insured on the property insurance provided in paragraph 5.06, the agreement between the CONTRAC-

TOR and the Subcontractor or Supplier will contain provisions whereby the Subcontractor or Supplier waives all rights against OWNER, CONTRACTOR, ENGINEER, ENGINEER's Consultants, and all other individuals or entities identified in the Supplementary Conditions to be listed as insureds or additional insureds (and the officers, directors, partners, employees, agents, and other consultants and subcontractors of each and any of them) for all losses and damages caused by, arising out of, relating to, or resulting from any of the perils or causes of loss covered by such policies and any other property insurance applicable to the Work. If the insurers on any such policies require separate waiver forms to be signed by any Subcontractor or Supplier, CONTRACTOR will obtain the same.

#### 6.07 *Patent Fees and Royalties*

A. CONTRACTOR shall pay all license fees and royalties and assume all costs incident to the use in the performance of the Work or the incorporation in the Work of any invention, design, process, product, or device which is the subject of patent rights or copyrights held by others. If a particular invention, design, process, product, or device is specified in the Contract Documents for use in the performance of the Work and if to the actual knowledge of OWNER or ENGINEER its use is subject to patent rights or copyrights calling for the payment of any license fee or royalty to others, the existence of such rights shall be disclosed by OWNER in the Contract Documents. To the fullest extent permitted by Laws and Regulations, CONTRACTOR shall indemnify and hold harmless OWNER, ENGINEER, ENGINEER's Consultants, and the officers, directors, partners, employees or agents, and other consultants of each and any of them from and against all claims, costs, losses, and damages (including but not limited to all fees and charges of engineers, architects, attorneys, and other professionals and all court or arbitration or other dispute resolution costs) arising out of or relating to any infringement of patent rights or copyrights incident to the use in the performance of the Work or resulting from the incorporation in the Work of any invention, design, process, product, or device not specified in the Contract Documents.

#### 6.08 *Permits*

A. Unless otherwise provided in the Supplementary Conditions, CONTRACTOR shall obtain and pay for all construction permits and licenses. OWNER shall assist CONTRACTOR, when necessary, in obtaining such permits and licenses. CONTRACTOR shall pay all governmental charges and inspection fees necessary for

the prosecution of the Work which are applicable at the time of opening of Bids, or, if there are no Bids, on the Effective Date of the Agreement. CONTRACTOR shall pay all charges of utility owners for connections to the Work, and OWNER shall pay all charges of such utility owners for capital costs related thereto, such as plant investment fees.

#### 6.09 *Laws and Regulations*

A. CONTRACTOR shall give all notices and comply with all Laws and Regulations applicable to the performance of the Work. Except where otherwise expressly required by applicable Laws and Regulations, neither OWNER nor ENGINEER shall be responsible for monitoring CONTRACTOR's compliance with any Laws or Regulations.

B. If CONTRACTOR performs any Work knowing or having reason to know that it is contrary to Laws or Regulations, CONTRACTOR shall bear all claims, costs, losses, and damages (including but not limited to all fees and charges of engineers, architects, attorneys, and other professionals and all court or arbitration or other dispute resolution costs) arising out of or relating to such Work; however, it shall not be CONTRACTOR's primary responsibility to make certain that the Specifications and Drawings are in accordance with Laws and Regulations, but this shall not relieve CONTRACTOR of CONTRACTOR's obligations under paragraph 3.03.

C. Changes in Laws or Regulations not known at the time of opening of Bids (or, on the Effective Date of the Agreement if there were no Bids) having an effect on the cost or time of performance of the Work may be the subject of an adjustment in Contract Price or Contract Times. If OWNER and CONTRACTOR are unable to agree on entitlement to or on the amount or extent, if any, of any such adjustment, a Claim may be made therefor as provided in paragraph 10.05.

#### 6.10\* *Taxes*

A. CONTRACTOR shall pay all sales, consumer, use, and other similar taxes required to be paid by CONTRACTOR in accordance with the Laws and Regulations of the place of the Project which are applicable during the performance of the Work.

#### 6.11\* *Use of Site and Other Areas*

##### A.\* *Limitation on Use of Site and Other Areas*

1. CONTRACTOR shall confine construction equipment, the storage of materials and equipment, and the operations of workers to the Site and other areas permitted by Laws and Regulations,

\*See Supplementary Conditions

and shall not unreasonably encumber the Site and other areas with construction equipment or other materials or equipment. CONTRACTOR shall assume full responsibility for any damage to any such land or area, or to the owner or occupant thereof, or of any adjacent land or areas resulting from the performance of the Work.

2. Should any claim be made by any such owner or occupant because of the performance of the Work, CONTRACTOR shall promptly settle with such other party by negotiation or otherwise resolve the claim by arbitration or other dispute resolution proceeding or at law.

3. To the fullest extent permitted by Laws and Regulations, CONTRACTOR shall indemnify and hold harmless OWNER, ENGINEER, ENGINEER's Consultant, and the officers, directors, partners, employees, agents, and other consultants of each and any of them from and against all claims, costs, losses, and damages (including but not limited to all fees and charges of engineers, architects, attorneys, and other professionals and all court or arbitration or other dispute resolution costs) arising out of or relating to any claim or action, legal or equitable, brought by any such owner or occupant against OWNER, ENGINEER, or any other party indemnified hereunder to the extent caused by or based upon CONTRACTOR's performance of the Work.

B. *Removal of Debris During Performance of the Work:* During the progress of the Work CONTRACTOR shall keep the Site and other areas free from accumulations of waste materials, rubbish, and other debris. Removal and disposal of such waste materials, rubbish, and other debris shall conform to applicable Laws and Regulations.

C. *Cleaning*: Prior to Substantial Completion of the Work CONTRACTOR shall clean the Site and make it ready for utilization by OWNER. At the completion of the Work CONTRACTOR shall remove from the Site all tools, appliances, construction equipment and machinery, and surplus materials and shall restore to original condition all property not designated for alteration by the Contract Documents.

D. *Loading Structures*: CONTRACTOR shall not load nor permit any part of any structure to be loaded in any manner that will endanger the structure, nor shall CONTRACTOR subject any part of the Work or adjacent property to stresses or pressures that will endanger it.

#### 6.12 *Record Documents*

A. CONTRACTOR shall maintain in a safe place at the Site one record copy of all Drawings, Specifications, Addenda, Written Amendments, Change Orders, Work Change Directives, Field Orders, and written interpretations and clarifications in good order and annotated to show changes made during construction. These record documents together with all approved Samples and a counterpart of all approved Shop Drawings will be available to ENGINEER for reference. Upon completion of the Work, these record documents, Samples, and Shop Drawings will be delivered to ENGINEER for OWNER.

#### 6.13 *Safety and Protection*

A. CONTRACTOR shall be solely responsible for initiating, maintaining and supervising all safety precautions and programs in connection with the Work. CONTRACTOR shall take all necessary precautions for the safety of, and shall provide the necessary protection to prevent damage, injury or loss to:

1. all persons on the Site or who may be affected by the Work;
2. all the Work and materials and equipment to be incorporated therein, whether in storage on or off the Site; and
3. other property at the Site or adjacent thereto, including trees, shrubs, lawns, walks, pavements, roadways, structures, utilities, and Underground Facilities not designated for removal, relocation, or replacement in the course of construction.

B. CONTRACTOR shall comply with all applicable Laws and Regulations relating to the safety of persons or property, or to the protection of persons or property from damage, injury, or loss; and shall erect and maintain all necessary safeguards for such safety and protection. CONTRACTOR shall notify owners of adjacent property and of Underground Facilities and other utility owners when prosecution of the Work may affect them, and shall cooperate with them in the protection, removal, relocation, and replacement of their property. All damage, injury, or loss to any property referred to in paragraph 6.13.A.2 or 6.13.A.3 caused, directly or indirectly, in whole or in part, by CONTRACTOR, any Subcontractor, Supplier, or any other individual or entity directly or indirectly employed by any of them to perform any of the Work, or anyone for whose acts any of them may be liable, shall be remedied by CONTRACTOR (except damage or loss attributable to the fault of Drawings or Specifications or to the acts or omissions of OWNER or ENGINEER or ENGINEER's Consultant, or anyone employed by any of them, or anyone for whose acts any of them may be liable, and not attributable, directly or indirectly, in whole or in part, to the fault or negligence of CONTRACTOR or any Subcontractor, Supplier, or other individual or entity directly or indirectly employed by any of them). CONTRACTOR's duties and responsibilities for safety and for protection of the Work shall continue until such time as all the Work is completed and ENGINEER has issued a notice to OWNER and CONTRACTOR in accordance with paragraph 14.07.B that the Work is acceptable (except as otherwise expressly provided in connection with Substantial Completion).

#### 6.14 *Safety Representative*

A. CONTRACTOR shall designate a qualified and experienced safety representative at the Site whose duties and responsibilities shall be the prevention of accidents and the maintaining and supervising of safety precautions and programs.

#### 6.15 *Hazard Communication Programs*

A. CONTRACTOR shall be responsible for coordinating any exchange of material safety data sheets or other hazard communication information required to be made available to or exchanged between or among employers at the Site in accordance with Laws or Regulations.

#### 6.16 *Emergencies*

A. In emergencies affecting the safety or protection of persons or the Work or property at the Site or adjacent thereto, CONTRACTOR is obligated to act to prevent threatened damage, injury, or loss. CONTRACTOR shall give ENGINEER prompt written notice if CONTRACTOR believes that any significant changes in the Work or variations from the Contract Documents have been caused thereby or are required as a result thereof. If ENGINEER determines that a change in the Contract Documents is required because of the action taken by CONTRACTOR in response to such an emergency, a Work Change Directive or Change Order will be issued.

#### 6.17\* *Shop Drawings and Samples*

A.\* CONTRACTOR shall submit Shop Drawings to ENGINEER for review and approval in accordance with the acceptable schedule of Shop Drawings and Sample submittals. All submittals will be identified as ENGINEER may require and in the number of copies specified in the General Requirements. The data shown on the Shop Drawings will be complete with respect to quantities, dimensions, specified performance and design criteria, materials, and similar data to show ENGINEER the services, materials, and equipment CONTRACTOR proposes to provide and to enable ENGINEER to review the information for the limited purposes required by paragraph 6.17.E.

B.\* CONTRACTOR shall also submit six (6) Samples to ENGINEER for review and approval in accordance with the acceptable schedule of Shop Drawings and Sample submittals. Each Sample will be identified clearly as to material, Supplier, pertinent data such as catalog numbers, and the use for which intended and otherwise as ENGINEER may require to enable ENGINEER to review the submittal for the limited purposes required by paragraph 6.17.E. The numbers of each Sample to be submitted will be as specified in the Specifications.

C. Where a Shop Drawing or Sample is required by the Contract Documents or the schedule of Shop Drawings and Sample submittals acceptable to ENGINEER as required by paragraph 2.07, any related Work performed prior to ENGINEER's review and approval of the pertinent submittal will be at the sole expense and responsibility of CONTRACTOR.

#### D. *Submittal Procedures*

1. Before submitting each Shop Drawing or Sample, CONTRACTOR shall have determined and verified:

a. all field measurements, quantities, dimensions, specified performance criteria, installation requirements, materials, catalog numbers, and similar information with respect thereto;

b. all materials with respect to intended use, fabrication, shipping, handling, storage, assembly, and installation pertaining to the performance of the Work;

c. all information relative to means, methods, techniques, sequences, and procedures of construction and safety precautions and programs incident thereto; and

d. CONTRACTOR shall also have reviewed and coordinated each Shop Drawing or

\*See Supplementary Conditions

Sample with other Shop Drawings and Samples and with the requirements of the Work and the Contract Documents.

2. Each submittal shall bear a stamp or specific written indication that CONTRACTOR has satisfied CONTRACTOR's obligations under the Contract Documents with respect to CONTRACTOR's review and approval of that submittal.

3. At the time of each submittal, CONTRACTOR shall give ENGINEER specific written notice of such variations, if any, that the Shop Drawing or Sample submitted may have from the requirements of the Contract Documents, such notice to be in a written communication separate from the submittal; and, in addition, shall cause a specific notation to be made on each Shop Drawing and Sample submitted to ENGINEER for review and approval of each such variation.

#### E. *ENGINEER's Review*

1. ENGINEER will timely review and approve Shop Drawings and Samples in accordance with the schedule of Shop Drawings and Sample submittals acceptable to ENGINEER. ENGINEER's review and approval will be only to determine if the items covered by the submittals

will, after installation or incorporation in the Work, conform to the information given in the Contract Documents and be compatible with the design concept of the completed Project as a functioning whole as indicated by the Contract Documents.

2. ENGINEER's review and approval will not extend to means, methods, techniques, sequences, or procedures of construction (except where a particular means, method, technique, sequence, or procedure of construction is specifically and expressly called for by the Contract Documents) or to safety precautions or programs incident thereto. The review and approval of a separate item as such will not indicate approval of the assembly in which the item functions.

3. ENGINEER's review and approval of Shop Drawings or Samples shall not relieve CONTRACTOR from responsibility for any variation from the requirements of the Contract Documents unless CONTRACTOR has in writing called ENGINEER's attention to each such variation at the time of each submittal as required by paragraph 6.17.D.3 and ENGINEER has given written approval of each such variation by specific written notation thereof incorporated in or accompanying the Shop Drawing or Sample approval; nor will any approval by ENGINEER relieve CONTRACTOR from responsibility for complying with the requirements of paragraph 6.17.D.1.

#### F. *Resubmittal Procedures*

1. CONTRACTOR shall make corrections required by ENGINEER and shall return the required number of corrected copies of Shop Drawings and submit as required new Samples for review and approval. CONTRACTOR shall direct specific attention in writing to revisions other than the corrections called for by ENGINEER on previous submittals.

#### 6.18 *Continuing the Work*

A. CONTRACTOR shall carry on the Work and adhere to the progress schedule during all disputes or disagreements with OWNER. No Work shall be delayed or postponed pending resolution of any disputes or disagreements, except as permitted by paragraph 15.04 or as OWNER and CONTRACTOR may otherwise agree in writing.

#### 6.19 *CONTRACTOR's General Warranty and Guarantee*

A. CONTRACTOR warrants and guarantees to OWNER, ENGINEER, and ENGINEER's Consultants that all Work will be in accordance with the Contract Documents and will not be defective. CONTRACTOR's warranty and guarantee hereunder excludes defects or damage caused by:

1. abuse, modification, or improper maintenance or operation by persons other than CONTRACTOR, Subcontractors, Suppliers, or any other individual or entity for whom CONTRACTOR is responsible; or
2. normal wear and tear under normal usage.

B. CONTRACTOR's obligation to perform and complete the Work in accordance with the Contract Documents shall be absolute. None of the following will constitute an acceptance of Work that is not in accordance with the Contract Documents or a release of CONTRACTOR's obligation to perform the Work in accordance with the Contract Documents:

1. observations by ENGINEER;
2. recommendation by ENGINEER or payment by OWNER of any progress or final payment;
3. the issuance of a certificate of Substantial Completion by ENGINEER or any payment related thereto by OWNER;
4. use or occupancy of the Work or any part thereof by OWNER;
5. any acceptance by OWNER or any failure to do so;
6. any review and approval of a Shop Drawing or Sample submittal or the issuance of a notice of acceptability by ENGINEER;
7. any inspection, test, or approval by others; or
8. any correction of defective Work by OWNER.

6.20 *Indemnification*

A. To the fullest extent permitted by Laws and Regulations, CONTRACTOR shall indemnify and hold harmless OWNER, ENGINEER, ENGINEER's Consultants, and the officers, directors, partners, employees, agents, and other consultants and subcontractors of each and any of them from and against all claims, costs, losses, and damages (including but not limited to all fees and charges of engineers, architects, attorneys, and other professionals and all court or arbitration or other dispute resolution costs) arising out of or relating to the performance of the Work, provided that any such claim, cost, loss, or damage:

1. is attributable to bodily injury, sickness, disease, or death, or to injury to or destruction of tangible property (other than the Work itself), including the loss of use resulting therefrom; and

2. is caused in whole or in part by any negligent act or omission of CONTRACTOR, any Subcontractor, any Supplier, or any individual or entity directly or indirectly employed by any of them to perform any of the Work or anyone for whose acts any of them may be liable, regardless of whether or not caused in part by any negligence or omission of an individual or entity indemnified hereunder or whether liability is imposed upon such indemnified party by Laws and Regulations regardless of the negligence of any such individual or entity.

B. In any and all claims against OWNER or ENGINEER or any of their respective consultants, agents, officers, directors, partners, or employees by any employee (or the survivor or personal representative of such employee) of CONTRACTOR, any Subcontractor, any Supplier, or any individual or entity directly or indirectly employed by any of them to perform any of the Work, or anyone for whose acts any of them may be liable, the indemnification obligation under paragraph 6.20.A shall not be limited in any way by any limitation on the amount or type of damages, compensation, or benefits payable by or for CONTRACTOR or any such Subcontractor, Supplier, or other individual or entity under workers' compensation acts, disability benefit acts, or other employee benefit acts.

C. The indemnification obligations of CONTRACTOR under paragraph 6.20.A shall not extend to the liability of ENGINEER and ENGINEER's Consultants or to the officers, directors, partners, employees, agents, and

other consultants and subcontractors of each and any of them arising out of:

1. the preparation or approval of, or the failure to prepare or approve, maps, Drawings, opinions, reports, surveys, Change Orders, designs, or Specifications; or

2. giving directions or instructions, or failing to give them, if that is the primary cause of the injury or damage.

ARTICLE 7 - OTHER WORK

---

7.01 *Related Work at Site*

A. OWNER may perform other work related to the Project at the Site by OWNER's employees, or let other direct contracts therefor, or have other work performed by utility owners. If such other work is not noted in the Contract Documents, then:

1. written notice thereof will be given to CONTRACTOR prior to starting any such other work; and

2. if OWNER and CONTRACTOR are unable to agree on entitlement to or on the amount or extent, if any, of any adjustment in the Contract Price or Contract Times that should be allowed as a result of such other work, a Claim may be made therefor as provided in paragraph 10.05.

B. CONTRACTOR shall afford each other contractor who is a party to such a direct contract and each utility owner (and OWNER, if OWNER is performing the other work with OWNER's employees) proper and safe access to the Site and a reasonable opportunity for the introduction and storage of materials and equipment and the execution of such other work and shall properly coordinate the Work with theirs. Unless otherwise provided in the Contract Documents, CONTRACTOR shall do all cutting, fitting, and patching of the Work that may be required to properly connect or otherwise make its several parts come together and properly integrate with such other work. CONTRACTOR shall not endanger any work of others by cutting, excavating, or otherwise altering their work and will only cut or alter their work with the written consent of ENGINEER and the others whose work will be affected. The duties and responsibilities of CONTRACTOR under this paragraph are for the benefit of

such utility owners and other contractors to the extent that there are comparable provisions for the benefit of CONTRACTOR in said direct contracts between OWNER and such utility owners and other contractors.

C. If the proper execution or results of any part of CONTRACTOR's Work depends upon work performed by others under this Article 7, CONTRACTOR shall inspect such other work and promptly report to ENGINEER in writing any delays, defects, or deficiencies in such other work that render it unavailable or unsuitable for the proper execution and results of CONTRACTOR's Work. CONTRACTOR's failure to so report will constitute an acceptance of such other work as fit and proper for integration with CONTRACTOR's Work except for latent defects and deficiencies in such other work.

#### 7.02 *Coordination*

A. If OWNER intends to contract with others for the performance of other work on the Project at the Site, the following will be set forth in Supplementary Conditions:

1. the individual or entity who will have authority and responsibility for coordination of the activities among the various contractors will be identified;
2. the specific matters to be covered by such authority and responsibility will be itemized; and
3. the extent of such authority and responsibilities will be provided.

B. Unless otherwise provided in the Supplementary Conditions, OWNER shall have sole authority and responsibility for such coordination.

### ARTICLE 8 - OWNER'S RESPONSIBILITIES

---

#### 8.01 *Communications to Contractor*

A. Except as otherwise provided in these General Conditions, OWNER shall issue all communications to CONTRACTOR through ENGINEER.

#### 8.02 *Replacement of ENGINEER*

A. In case of termination of the employment of ENGINEER, OWNER shall appoint an engineer to whom CONTRACTOR makes no reasonable objection, whose status under the Contract Documents shall be that of the former ENGINEER.

#### 8.03 *Furnish Data*

A. OWNER shall promptly furnish the data required of OWNER under the Contract Documents.

#### 8.04 *Pay Promptly When Due*

A. OWNER shall make payments to CONTRACTOR promptly when they are due as provided in paragraphs 14.02.C and 14.07.C.

#### 8.05 *Lands and Easements; Reports and Tests*

A. OWNER's duties in respect of providing lands and easements and providing engineering surveys to establish reference points are set forth in paragraphs 4.01 and 4.05. Paragraph 4.02 refers to OWNER's identifying and making available to CONTRACTOR copies of reports of explorations and tests of subsurface conditions and drawings of physical conditions in or relating to existing surface or subsurface structures at or contiguous to the Site that have been utilized by ENGINEER in preparing the Contract Documents.

\*See Supplementary Conditions

#### 8.06\* *Insurance*

A.\* OWNER's responsibilities, if any, in respect to purchasing and maintaining liability and property insurance are set forth in Article 5.

#### 8.07 *Change Orders*

A. OWNER is obligated to execute Change Orders as indicated in paragraph 10.03.

#### 8.08 *Inspections, Tests, and Approvals*

A. OWNER's responsibility in respect to certain inspections, tests, and approvals is set forth in paragraph 13.03.B.

8.09 *Limitations on OWNER's Responsibilities*

A. The OWNER shall not supervise, direct, or have control or authority over, nor be responsible for, CONTRACTOR's means, methods, techniques, sequences, or procedures of construction, or the safety precautions and programs incident thereto, or for any failure of CONTRACTOR to comply with Laws and Regulations applicable to the performance of the Work. OWNER will not be responsible for CONTRACTOR's failure to perform the Work in accordance with the Contract Documents.

8.10 *Undisclosed Hazardous Environmental Condition*

A. OWNER's responsibility in respect to an undisclosed Hazardous Environmental Condition is set forth in paragraph 4.06.

8.11 *Evidence of Financial Arrangements*

A. If and to the extent OWNER has agreed to furnish CONTRACTOR reasonable evidence that financial arrangements have been made to satisfy OWNER's obligations under the Contract Documents, OWNER's responsibility in respect thereof will be as set forth in the Supplementary Conditions.

ARTICLE 9 - ENGINEER'S STATUS DURING CONSTRUCTION

---

9.01 *OWNER'S Representative*

A. ENGINEER will be OWNER's representative during the construction period. The duties and responsibilities and the limitations of authority of ENGINEER as OWNER's representative during construction are set forth in the Contract Documents and will not be changed without written consent of OWNER and ENGINEER.

9.02 *Visits to Site*

A. ENGINEER will make visits to the Site at intervals appropriate to the various stages of construction as ENGINEER deems necessary in order to observe as an experienced and qualified design professional the progress that has been made and the quality of the various aspects of CONTRACTOR's executed Work. Based on information obtained during such visits and

observations, ENGINEER, for the benefit of OWNER, will determine, in general, if the Work is proceeding in accordance with the Contract Documents. ENGINEER will not be required to make exhaustive or continuous inspections on the Site to check the quality or quantity of the Work. ENGINEER's efforts will be directed toward providing for OWNER a greater degree of confidence that the completed Work will conform generally to the Contract Documents. On the basis of such visits and observations, ENGINEER will keep OWNER informed of the progress of the Work and will endeavor to guard OWNER against defective Work.

B. ENGINEER's visits and observations are subject to all the limitations on ENGINEER's authority and responsibility set forth in paragraph 9.10, and particularly, but without limitation, during or as a result of ENGINEER's visits or observations of CONTRACTOR's Work ENGINEER will not supervise, direct, control, or have authority over or be responsible for CONTRACTOR's means, methods, techniques, sequences, or procedures of construction, or the safety precautions and programs incident thereto, or for any failure of CONTRACTOR to comply with Laws and Regulations applicable to the performance of the Work.

9.03\* *Project Representative*

A. If OWNER and ENGINEER agree, ENGINEER will furnish a Resident Project Representative to assist ENGINEER in providing more extensive observation of the Work. The responsibilities and authority and limitations thereon of any such Resident Project Representative and assistants will be as provided in paragraph 9.10 and in the Supplementary Conditions. If OWNER designates another representative or agent to represent OWNER at the Site who is not ENGINEER's Consultant, agent or employee,

\*See Supplementary Conditions

the responsibilities and authority and limitations thereon of such other individual or entity will be as provided in the Supplementary Conditions.

9.04 *Clarifications and Interpretations*

A. ENGINEER will issue with reasonable promptness such written clarifications or interpretations of the requirements of the Contract Documents as ENGINEER may determine necessary, which shall be consistent with the intent of and reasonably inferable from the Contract Documents.

ments. Such written clarifications and interpretations will be binding on OWNER and CONTRACTOR. If OWNER and CONTRACTOR are unable to agree on entitlement to or on the amount or extent, if any, of any adjustment in the Contract Price or Contract Times, or both, that should be allowed as a result of a written clarification or interpretation, a Claim may be made therefor as provided in paragraph 10.05.

9.05 *Authorized Variations in Work*

A. ENGINEER may authorize minor variations in the Work from the requirements of the Contract Documents which do not involve an adjustment in the Contract Price or the Contract Times and are compatible with the design concept of the completed Project as a functioning whole as indicated by the Contract Documents. These may be accomplished by a Field Order and will be binding on OWNER and also on CONTRACTOR, who shall perform the Work involved promptly. If OWNER and CONTRACTOR are unable to agree on entitlement to or on the amount or extent, if any, of any adjustment in the Contract Price or Contract Times, or both, as a result of a Field Order, a Claim may be made therefor as provided in paragraph 10.05.

9.06 *Rejecting Defective Work*

A. ENGINEER will have authority to disapprove or reject Work which ENGINEER believes to be defective, or that ENGINEER believes will not produce a completed Project that conforms to the Contract Documents or that will prejudice the integrity of the design concept of the completed Project as a functioning whole as indicated by the Contract Documents. ENGINEER will also have authority to require special inspection or testing of the Work as provided in paragraph 13.04, whether or not the Work is fabricated, installed, or completed.

9.07 *Shop Drawings, Change Orders and Payments*

A. In connection with ENGINEER's authority as to Shop Drawings and Samples, see paragraph 6.17.

B. In connection with ENGINEER's authority as to Change Orders, see Articles 10, 11, and 12.

C. In connection with ENGINEER's authority as to Applications for Payment, see Article 14.

9.08 *Determinations for Unit Price Work*

A. ENGINEER will determine the actual quantities and classifications of Unit Price Work performed by CONTRACTOR. ENGINEER will review with CONTRACTOR the ENGINEER's preliminary determinations on such matters before rendering a written decision thereon (by recommendation of an Application for Payment or otherwise). ENGINEER's written decision thereon will be final and binding (except as modified by ENGINEER to reflect changed factual conditions or more accurate data) upon OWNER and CONTRACTOR, subject to the provisions of paragraph 10.05.

9.09 *Decisions on Requirements of Contract Documents and Acceptability of Work*

A. ENGINEER will be the initial interpreter of the requirements of the Contract Documents and judge of the acceptability of the Work thereunder. Claims, disputes and other matters relating to the acceptability of the Work, the quantities and classifications of Unit Price Work, the interpretation of the requirements of the Contract Documents pertaining to the performance of the Work, and Claims seeking changes in the Contract Price or Contract Times will be referred initially to ENGINEER in writing, in accordance with the provisions of paragraph 10.05, with a request for a formal decision.

B. When functioning as interpreter and judge under this paragraph 9.09, ENGINEER will not show partiality to OWNER or CONTRACTOR and will not be liable in connection with any interpretation or decision rendered in good faith in such capacity. The rendering of a decision by ENGINEER pursuant to this paragraph 9.09 with respect to any such Claim, dispute, or other matter (except any which have been waived by the making or acceptance of final payment as provided in paragraph 14.07) will be a condition precedent to any exercise by OWNER or CONTRACTOR of such rights or remedies as either may otherwise have under the Contract Documents or by Laws or Regulations in respect of any such Claim, dispute, or other matter.

\*See Supplementary Conditions

9.10 *Limitations on ENGINEER's Authority and Responsibilities*

A. Neither ENGINEER's authority or responsibility under this Article 9 or under any other provision of the Contract Documents nor any decision made by ENGINEER in good faith either to exercise or not exercise such

authority or responsibility or the undertaking, exercise, or performance of any authority or responsibility by ENGINEER shall create, impose, or give rise to any duty in contract, tort, or otherwise owed by ENGINEER to CONTRACTOR, any Subcontractor, any Supplier, any other individual or entity, or to any surety for or employee or agent of any of them.

B. ENGINEER will not supervise, direct, control, or have authority over or be responsible for CONTRACTOR's means, methods, techniques, sequences, or procedures of construction, or the safety precautions and programs incident thereto, or for any failure of CONTRACTOR to comply with Laws and Regulations applicable to the performance of the Work. ENGINEER will not be responsible for CONTRACTOR's failure to perform the Work in accordance with the Contract Documents.

C. ENGINEER will not be responsible for the acts or omissions of CONTRACTOR or of any Subcontractor, any Supplier, or of any other individual or entity performing any of the Work.

D. ENGINEER's review of the final Application for Payment and accompanying documentation and all maintenance and operating instructions, schedules, guarantees, Bonds, certificates of inspection, tests and approvals, and other documentation required to be delivered by paragraph 14.07.A will only be to determine generally that their content complies with the requirements of, and in the case of certificates of inspections, tests, and approvals that the results certified indicate compliance with, the Contract Documents.

E. The limitations upon authority and responsibility set forth in this paragraph 9.10 shall also apply to ENGINEER's Consultants, Resident Project Representative, and assistants. See Article 18.

## ARTICLE 10 - CHANGES IN THE WORK; CLAIMS

---

### 10.01 *Authorized Changes in the Work*

A. Without invalidating the Agreement and without notice to any surety, OWNER may, at any time or from time to time, order additions, deletions, or revisions in the Work by a Written Amendment, a Change Order, or a Work Change Directive. Upon receipt of any such document, CONTRACTOR shall promptly proceed with the Work involved which will be performed under the

applicable conditions of the Contract Documents (except as otherwise specifically provided).

B. If OWNER and CONTRACTOR are unable to agree on entitlement to, or on the amount or extent, if any, of an adjustment in the Contract Price or Contract Times, or both, that should be allowed as a result of a Work Change Directive, a Claim may be made therefor as provided in paragraph 10.05.

### 10.02 *Unauthorized Changes in the Work*

A. CONTRACTOR shall not be entitled to an increase in the Contract Price or an extension of the Contract Times with respect to any work performed that is not required by the Contract Documents as amended, modified, or supplemented as provided in paragraph 3.04, except in the case of an emergency as provided in paragraph 6.16 or in the case of uncovering Work as provided in paragraph 13.04.B.

### 10.03 *Execution of Change Orders*

A. OWNER and CONTRACTOR shall execute appropriate Change Orders recommended by ENGINEER (or Written Amendments) covering:

1. changes in the Work which are: (i) ordered by OWNER pursuant to paragraph 10.01.A, (ii) required because of acceptance of defective Work under paragraph 13.08.A or OWNER's correction of defective Work under paragraph 13.09, or (iii) agreed to by the parties;

2. changes in the Contract Price or Contract Times which are agreed to by the parties, including any undisputed sum or amount of time for Work actually performed in accordance with a Work Change Directive; and

3. changes in the Contract Price or Contract Times which embody the substance of any written decision rendered by ENGINEER pursuant to paragraph 10.05; provided that, in lieu of executing any such Change Order, an appeal may be taken from any such decision in accordance with the provisions of the Contract Documents and applicable Laws and Regulations, but during any such appeal, CONTRACTOR shall carry on the Work and adhere to the progress schedule as provided in paragraph 6.18.A.

10.04 *Notification to Surety*

A. If notice of any change affecting the general scope of the Work or the provisions of the Contract Documents (including, but not limited to, Contract Price or Contract Times) is required by the provisions of any Bond to be given to a surety, the giving of any such notice will be CONTRACTOR's responsibility. The amount of each applicable Bond will be adjusted to reflect the effect of any such change.

10.05 *Claims and Disputes*

A. *Notice:* Written notice stating the general nature of each Claim, dispute, or other matter shall be delivered by the claimant to ENGINEER and the other party to the Contract promptly (but in no event later than 30 days) after the start of the event giving rise thereto. Notice of the amount or extent of the Claim, dispute, or other matter with supporting data shall be delivered to the ENGINEER and the other party to the Contract within 60 days after the start of such event (unless ENGINEER allows additional time for claimant to submit additional or more accurate data in support of such Claim, dispute, or other matter). A Claim for an adjustment in Contract Price shall be prepared in accordance with the provisions of paragraph 12.01.B. A Claim for an adjustment in Contract Time shall be prepared in accordance with the provisions of paragraph 12.02.B. Each Claim shall be accompanied by claimant's written statement that the adjustment claimed is the entire adjustment to which the claimant believes it is entitled as a result of said event. The opposing party shall submit any response to ENGINEER and the claimant within 30 days after receipt of the claimant's last submittal (unless ENGINEER allows additional time).

B. *ENGINEER's Decision:* ENGINEER will render a formal decision in writing within 30 days after receipt of the last submittal of the claimant or the last submittal of the opposing party, if any. ENGINEER's written decision on such Claim, dispute, or other matter will be final and binding upon OWNER and CONTRACTOR unless:

1. an appeal from ENGINEER's decision is taken within the time limits and in accordance with the dispute resolution procedures set forth in Article 16; or
2. if no such dispute resolution procedures have been set forth in Article 16, a written notice of intention to appeal from ENGINEER's written decision is delivered by OWNER or CONTRACTOR to the other and to ENGINEER within 30 days

after the date of such decision, and a formal proceeding is instituted by the appealing party in a forum of competent jurisdiction within 60 days after the date of such decision or within 60 days after Substantial Completion, whichever is later (unless otherwise agreed in writing by OWNER and CONTRACTOR), to exercise such rights or remedies as the appealing party may have with respect to such Claim, dispute, or other matter in accordance with applicable Laws and Regulations.

C. If ENGINEER does not render a formal decision in writing within the time stated in paragraph 10.05.B, a decision denying the Claim in its entirety shall be deemed to have been issued 31 days after receipt of the last submittal of the claimant or the last submittal of the opposing party, if any.

D. No Claim for an adjustment in Contract Price or Contract Times (or Milestones) will be valid if not submitted in accordance with this paragraph 10.05.

ARTICLE 11 - COST OF THE WORK; CASH ALLOWANCES; UNIT PRICE WORK

---

11.01 *Cost of the Work*

A. *Costs Included:* The term Cost of the Work means the sum of all costs necessarily incurred and paid by CONTRACTOR in the proper performance of the Work. When the value of any Work covered by a Change Order or when a Claim for an adjustment in Contract Price is determined on the basis of Cost of the Work, the costs to be reimbursed to CONTRACTOR will be only those additional or incremental costs required because of the change in the Work or because of the event giving rise to the Claim. Except as otherwise may be agreed to in writing by OWNER, such costs shall be in amounts no higher than those prevailing in the locality of the Project, shall include only the following items, and shall not include any of the costs itemized in paragraph 11.01.B.

1. Payroll costs for employees in the direct employ of CONTRACTOR in the performance of the Work under schedules of job classifications agreed upon by OWNER and CONTRACTOR. Such employees shall include without limitation superintendents, foremen, and other personnel employed full time at the Site. Payroll costs for employees not employed full time on the Work

shall be apportioned on the basis of their time spent on the Work. Payroll costs shall include, but not be limited to, salaries and wages plus the cost of fringe benefits, which shall include social security contributions, unemployment, excise, and payroll taxes, workers' compensation, health and retirement benefits, bonuses, sick leave, vacation and holiday pay applicable thereto. The expenses of performing Work outside of regular working hours, on Saturday, Sunday, or legal holidays, shall be included in the above to the extent authorized by OWNER.

2. Cost of all materials and equipment furnished and incorporated in the Work, including costs of transportation and storage thereof, and Suppliers' field services required in connection therewith. All cash discounts shall accrue to CONTRACTOR unless OWNER deposits funds with CONTRACTOR with which to make payments, in which case the cash discounts shall accrue to OWNER. All trade discounts, rebates and refunds and returns from sale of surplus materials and equipment shall accrue to OWNER, and CONTRACTOR shall make provisions so that they may be obtained.

3. Payments made by CONTRACTOR to Subcontractors for Work performed by Subcontractors. If required by OWNER, CONTRACTOR shall obtain competitive bids from subcontractors acceptable to OWNER and CONTRACTOR and shall deliver such bids to OWNER, who will then determine, with the advice of ENGINEER, which bids, if any, will be acceptable. If any subcontract provides that the Subcontractor is to be paid on the basis of Cost of the Work plus a fee, the Subcontractor's Cost of the Work and fee shall be determined in the same manner as CONTRACTOR's Cost of the Work and fee as provided in this paragraph 11.01.

4. Costs of special consultants (including but not limited to engineers, architects, testing laboratories, surveyors, attorneys, and accountants) employed for services specifically related to the Work.

5. Supplemental costs including the following:

a. The proportion of necessary transportation, travel, and subsistence expenses of

CONTRACTOR's employees incurred in discharge of duties connected with the Work.

b. Cost, including transportation and maintenance, of all materials, supplies, equipment, machinery, appliances, office, and temporary facilities at the Site, and hand tools not owned by the workers, which are consumed in the performance of the Work, and cost, less market value, of such items used but not consumed which remain the property of CONTRACTOR.

c. Rentals of all construction equipment and machinery, and the parts thereof whether rented from CONTRACTOR or others in accordance with rental agreements approved by OWNER with the advice of ENGINEER, and the costs of transportation, loading, unloading, assembly, dismantling, and removal thereof. All such costs shall be in accordance with the terms of said rental agreements. The rental of any such equipment, machinery, or parts shall cease when the use thereof is no longer necessary for the Work.

d. Sales, consumer, use, and other similar taxes related to the Work, and for which CONTRACTOR is liable, imposed by Laws and Regulations.

e. Deposits lost for causes other than negligence of CONTRACTOR, any Subcontractor, or anyone directly or indirectly employed by any of them or for whose acts any of them may be liable, and royalty payments and fees for permits and licenses.

f. Losses and damages (and related expenses) caused by damage to the Work, not compensated by insurance or otherwise, sustained by CONTRACTOR in connection with the performance of the Work (except losses and damages within the deductible amounts of property insurance established in accordance with paragraph 5.06.D), provided such losses and damages have resulted from causes other than the negligence of CONTRACTOR, any Subcontractor, or anyone directly or indirectly employed by any of them or for whose acts any of them may be liable. Such losses shall include settlements made with the written consent and approval of OWNER. No such losses, damages, and expenses shall be included in the Cost of the Work for the purpose of determining CONTRACTOR's fee.

g. The cost of utilities, fuel, and sanitary facilities at the Site.

h. Minor expenses such as telegrams, long distance telephone calls, telephone service at the Site, expressage, and similar petty cash items in connection with the Work.

i. When the Cost of the Work is used to determine the value of a Change Order or of a Claim, the cost of premiums for additional Bonds and insurance required because of the changes in the Work or caused by the event giving rise to the Claim.

j. When all the Work is performed on the basis of cost-plus, the costs of premiums for all Bonds and insurance CONTRACTOR is required by the Contract Documents to purchase and maintain.

B. *Costs Excluded:* The term Cost of the Work shall not include any of the following items:

1. Payroll costs and other compensation of CONTRACTOR's officers, executives, principals (of partnerships and sole proprietorships), general managers, engineers, architects, estimators, attorneys, auditors, accountants, purchasing and contracting agents, expeditors, timekeepers, clerks, and other personnel employed by CONTRACTOR, whether at the Site or in CONTRACTOR's principal or branch office for general administration of the Work and not specifically included in the agreed upon schedule of job classifications referred to in paragraph 11.01.A.1 or specifically covered by paragraph 11.01.A.4, all of which are to be considered administrative costs covered by the CONTRACTOR's fee.

2. Expenses of CONTRACTOR's principal and branch offices other than CONTRACTOR's office at the Site.

3. Any part of CONTRACTOR's capital expenses, including interest on CONTRACTOR's capital employed for the Work and charges against CONTRACTOR for delinquent payments.

4. Costs due to the negligence of CONTRACTOR, any Subcontractor, or anyone directly or indirectly employed by any of them or for whose acts any of them may be liable, including but not

limited to, the correction of defective Work, disposal of materials or equipment wrongly supplied, and making good any damage to property.

5. Other overhead or general expense costs of any kind and the costs of any item not specifically and expressly included in paragraphs 11.01.A and 11.01.B.

C. *CONTRACTOR's Fee:* When all the Work is performed on the basis of cost-plus, CONTRACTOR's fee shall be determined as set forth in the Agreement. When the value of any Work covered by a Change Order or when a Claim for an adjustment in Contract Price is determined on the basis of Cost of the Work, CONTRACTOR's fee shall be determined as set forth in paragraph 12.01.C.

D. *Documentation:* Whenever the Cost of the Work for any purpose is to be determined pursuant to paragraphs 11.01.A and 11.01.B, CONTRACTOR will establish and maintain records thereof in accordance with generally accepted accounting practices and submit in a form acceptable to ENGINEER an itemized cost breakdown together with supporting data.

#### 11.02 *Cash Allowances*

A. It is understood that CONTRACTOR has included in the Contract Price all allowances so named in the Contract Documents and shall cause the Work so covered to be performed for such sums as may be acceptable to OWNER and ENGINEER. CONTRACTOR agrees that:

1. the allowances include the cost to CONTRACTOR (less any applicable trade discounts) of materials and equipment required by the allowances to be delivered at the Site, and all applicable taxes; and

2. CONTRACTOR's costs for unloading and handling on the Site, labor, installation costs, overhead, profit, and other expenses contemplated for the allowances have been included in the Contract Price and not in the allowances, and no demand for additional payment on account of any of the foregoing will be valid.

B. Prior to final payment, an appropriate Change Order will be issued as recommended by ENGINEER to reflect actual amounts due CONTRACTOR on account of

Work covered by allowances, and the Contract Price shall be correspondingly adjusted.

#### 11.03 *Unit Price Work*

A. Where the Contract Documents provide that all or part of the Work is to be Unit Price Work, initially the Contract Price will be deemed to include for all Unit Price Work an amount equal to the sum of the unit price for each separately identified item of Unit Price Work times the estimated quantity of each item as indicated in the Agreement. The estimated quantities of items of Unit Price Work are not guaranteed and are solely for the purpose of comparison of Bids and determining an initial Contract Price. Determinations of the actual quantities and classifications of Unit Price Work performed by CONTRACTOR will be made by ENGINEER subject to the provisions of paragraph 9.08.

B. Each unit price will be deemed to include an amount considered by CONTRACTOR to be adequate to cover CONTRACTOR's overhead and profit for each separately identified item.

C. OWNER or CONTRACTOR may make a Claim for an adjustment in the Contract Price in accordance with paragraph 10.05 if:

1. the quantity of any item of Unit Price Work performed by CONTRACTOR differs materially and significantly from the estimated quantity of such item indicated in the Agreement; and

2. there is no corresponding adjustment with respect any other item of Work; and

3. if CONTRACTOR believes that CONTRACTOR is entitled to an increase in Contract Price as a result of having incurred additional expense or OWNER believes that OWNER is entitled to a decrease in Contract Price and the parties are unable to agree as to the amount of any such increase or decrease.

#### ARTICLE 12 - CHANGE OF CONTRACT PRICE; CHANGE OF CONTRACT TIMES

---

#### 12.01\* *Change of Contract Price*

A. The Contract Price may only be changed by a Change Order or by a Written Amendment. Any Claim for an adjustment in the Contract Price shall be based on written notice submitted by the party making the Claim to the ENGINEER and the other party to the Contract in accordance with the provisions of paragraph 10.05.

B.\* The value of any Work covered by a Change Order or of any Claim for an adjustment in the Contract Price will be determined as follows:

1. where the Work involved is covered by unit prices contained in the Contract Documents, by application of such unit prices to the quantities of the items involved (subject to the provisions of paragraph 11.03 ); or

2. where the Work involved is not covered by unit prices contained in the Contract Documents, by a mutually agreed lump sum (which may include an allowance for overhead and profit not necessarily in accordance with paragraph 12.01.C.2); or

3. where the Work involved is not covered by unit prices contained in the Contract Documents and agreement to a lump sum is not reached under paragraph 12.01.B.2, on the basis of the Cost of the Work (determined as provided in paragraph 11.01) plus a CONTRACTOR's fee for overhead and profit (determined as provided in paragraph 12.01.C).

C. *CONTRACTOR's Fee*: The CONTRACTOR's fee for overhead and profit shall be determined as follows:

1. a mutually acceptable fixed fee; or

2. if a fixed fee is not agreed upon, then a fee based on the following percentages of the various portions of the Cost of the Work:

- a. for costs incurred under paragraphs 11.01.A.1 and 11.01.A.2, the CONTRACTOR's fee shall be 15 percent;

b. for costs incurred under paragraph 11.01.A.3, the CONTRACTOR's fee shall be five percent;

c. where one or more tiers of subcontracts are on the basis of Cost of the Work plus a fee and no fixed fee is agreed upon, the intent of paragraph 12.01.C.2.a is that the Subcontractor who actually performs the Work, at whatever tier, will be paid a fee of 15 percent of the costs incurred by such Subcontractor under paragraphs 11.01.A.1 and 11.01.A.2 and that any higher tier Subcontractor and CONTRACTOR will each be paid a fee of five percent of the amount paid to the next lower tier Subcontractor;

\*See Supplementary Conditions

d. no fee shall be payable on the basis of costs itemized under paragraphs 11.01.A.4, 11.01.A.5, and 11.01.B;

e. the amount of credit to be allowed by CONTRACTOR to OWNER for any change which results in a net decrease in cost will be the amount of the actual net decrease in cost plus a deduction in CONTRACTOR's fee by an amount equal to five percent of such net decrease; and

f. when both additions and credits are involved in any one change, the adjustment in CONTRACTOR's fee shall be computed on the basis of the net change in accordance with paragraphs 12.01.C.2.a through 12.01.C.2.e, inclusive.

#### 12.02 *Change of Contract Times*

A. The Contract Times (or Milestones) may only be changed by a Change Order or by a Written Amendment. Any Claim for an adjustment in the Contract Times (or Milestones) shall be based on written notice submitted by the party making the claim to the ENGINEER and the other party to the Contract in accordance with the provisions of paragraph 10.05.

B. Any adjustment of the Contract Times (or Milestones) covered by a Change Order or of any Claim for an adjustment in the Contract Times (or Milestones)

will be determined in accordance with the provisions of this Article 12.

#### 12.03 *Delays Beyond CONTRACTOR's Control*

A. Where CONTRACTOR is prevented from completing any part of the Work within the Contract Times (or Milestones) due to delay beyond the control of CONTRACTOR, the Contract Times (or Milestones) will be extended in an amount equal to the time lost due to such delay if a Claim is made therefor as provided in paragraph 12.02.A. Delays beyond the control of CONTRACTOR shall include, but not be limited to, acts or neglect by OWNER, acts or neglect of utility owners or other contractors performing other work as contemplated by Article 7, fires, floods, epidemics, abnormal weather conditions, or acts of God.

#### 12.04 *Delays Within CONTRACTOR's Control*

A. The Contract Times (or Milestones) will not be extended due to delays within the control of CONTRACTOR. Delays attributable to and within the control of a Subcontractor or Supplier shall be deemed to be delays within the control of CONTRACTOR.

#### 12.05 *Delays Beyond OWNER's and CONTRACTOR's Control*

A. Where CONTRACTOR is prevented from completing any part of the Work within the Contract Times (or Milestones) due to delay beyond the control of both OWNER and CONTRACTOR, an extension of the Contract Times (or Milestones) in an amount equal to the time lost due to such delay shall be CONTRACTOR's sole and exclusive remedy for such delay.

#### 12.06 *Delay Damages*

A. In no event shall OWNER or ENGINEER be liable to CONTRACTOR, any Subcontractor, any Supplier, or any other person or organization, or to any surety for or employee or agent of any of them, for damages arising out of or resulting from:

1. delays caused by or within the control of CONTRACTOR; or

2. delays beyond the control of both OWNER and CONTRACTOR including but not limited to fires, floods, epidemics, abnormal weather conditions, acts of God, or acts or neglect by utility

owners or other contractors performing other work as contemplated by Article 7.

B. Nothing in this paragraph 12.06 bars a change in Contract Price pursuant to this Article 12 to compensate CONTRACTOR due to delay, interference, or disruption directly attributable to actions or inactions of OWNER or anyone for whom OWNER is responsible.

#### ARTICLE 13 - TESTS AND INSPECTIONS; CORRECTION, REMOVAL OR ACCEPTANCE OF DEFECTIVE WORK

---

##### 13.01 *Notice of Defects*

A. Prompt notice of all defective Work of which OWNER or ENGINEER has actual knowledge will be given to CONTRACTOR. All defective Work may be rejected, corrected, or accepted as provided in this Article 13.

##### 13.02\* *Access to Work*

A. OWNER, ENGINEER, ENGINEER's Consultants, other representatives and personnel of OWNER, independent testing laboratories, and governmental agencies with jurisdictional interests will have access to the Site and the Work at reasonable times for their observation, inspecting, and testing. CONTRACTOR shall provide them proper and safe conditions for such access and advise them of CONTRACTOR's Site safety procedures and programs so that they may comply therewith as applicable.

##### 13.03\* *Tests and Inspections*

A. CONTRACTOR shall give ENGINEER timely notice of readiness of the Work for all required inspections, tests, or approvals and shall cooperate with inspection and testing personnel to facilitate required inspections or tests.

B.\* OWNER shall employ and pay for the services of an independent testing laboratory to perform all inspections, tests, or approvals required by the Contract Documents except:

1. for inspections, tests, or approvals covered by paragraphs 13.03.C and 13.03.D below;

2. that costs incurred in connection with tests or inspections conducted pursuant to paragraph 13.04.B shall be paid as provided in said paragraph 13.04.B; and

3. as otherwise specifically provided in the Contract Documents.

C. If Laws or Regulations of any public body having jurisdiction require any Work (or part thereof) specifically to be inspected, tested, or approved by an employee or other representative of such public body, CONTRACTOR shall assume full responsibility for arranging and obtaining such inspections, tests, or approvals, pay all costs in connection therewith, and furnish ENGINEER the required certificates of inspection or approval.

D. CONTRACTOR shall be responsible for arranging and obtaining and shall pay all costs in connection with any inspections, tests, or approvals required for OWNER's and ENGINEER's acceptance of materials or equipment to be incorporated in the Work; or acceptance of materials, mix designs, or equipment submitted for approval prior to CONTRACTOR's purchase thereof for incorporation in the Work. Such inspections, tests, or approvals shall be performed by organizations acceptable to OWNER and ENGINEER.

E. If any Work (or the work of others) that is to be inspected, tested, or approved is covered by CONTRACTOR without written concurrence of ENGINEER, it must, if requested by ENGINEER, be uncovered for observation.

F. Uncovering Work as provided in paragraph 13.03.E shall be at CONTRACTOR's expense unless CONTRACTOR has given ENGINEER timely notice of CONTRACTOR's intention to cover the same and ENGINEER has not acted with reasonable promptness in response to such notice.

##### 13.04 *Uncovering Work*

A. If any Work is covered contrary to the written request of ENGINEER, it must, if requested by ENGINEER, be uncovered for ENGINEER's observation and replaced at CONTRACTOR's expense.

B. If ENGINEER considers it necessary or advisable that covered Work be observed by ENGINEER or inspected or tested by others, CONTRACTOR, at ENGINEER's request, shall uncover, expose, or otherwise make available for observation, inspection, or testing as ENGINEER may require, that portion of the Work in

question, furnishing all necessary labor, material, and equipment. If it is found that such Work is defective, CONTRACTOR shall pay all Claims, costs, losses, and damages (including but not limited to all fees and charges of engineers, architects, attorneys, and other professionals and all court or arbitration or other dispute resolution costs) arising out of or relating to such uncovering, exposure, observation, inspection, and testing, and of satisfactory replacement or reconstruction (including but not limited to all costs of repair or replacement of work of others); and OWNER shall be entitled to an appropriate decrease in the Contract Price. If the parties are unable to agree as to the amount thereof, OWNER may make a Claim therefor as provided in paragraph 10.05. If, however, such Work is not found to be defective, CONTRACTOR shall be allowed an increase in the Contract Price or an extension of the Contract Times (or Milestones), or both, directly attributable to such uncovering, exposure, observation, inspection, testing, replacement, and reconstruction. If the parties are unable to agree as to the amount or extent thereof, CONTRACTOR may make a Claim therefor as provided in paragraph 10.05.

\*See Supplementary Conditions

#### 13.05 *OWNER May Stop the Work*

A. If the Work is defective, or CONTRACTOR fails to supply sufficient skilled workers or suitable materials or equipment, or fails to perform the Work in such a way that the completed Work will conform to the Contract Documents, OWNER may order CONTRACTOR to stop the Work, or any portion thereof, until the cause for such order has been eliminated; however, this right of OWNER to stop the Work shall not give rise to any duty on the part of OWNER to exercise this right for the benefit of CONTRACTOR, any Subcontractor, any Supplier, any other individual or entity, or any surety for, or employee or agent of any of them.

#### 13.06 *Correction or Removal of Defective Work*

A. CONTRACTOR shall correct all defective Work, whether or not fabricated, installed, or completed, or, if the Work has been rejected by ENGINEER, remove it from the Project and replace it with Work that is not defective. CONTRACTOR shall pay all Claims, costs, losses, and damages (including but not limited to all fees and charges of engineers, architects, attorneys, and other professionals and all court or arbitration or other dispute resolution costs) arising out of or relating to such correction or removal (including but not limited to all costs of repair or replacement of work of others).

#### 13.07 *Correction Period*

A. If within one year after the date of Substantial Completion or such longer period of time as may be prescribed by Laws or Regulations or by the terms of any applicable special guarantee required by the Contract Documents, or by any specific provision of the Contract Documents, any Work is found to be defective, or if the repair of any damages to the land or areas made available for CONTRACTOR's use by OWNER or permitted by Laws and Regulations as contemplated in paragraph 6.11.A is found to be defective, CONTRACTOR shall promptly, without cost to OWNER and in accordance with OWNER's written instructions: (i) repair such defective land or areas, or (ii) correct such defective Work or, if the defective Work has been rejected by OWNER, remove it from the Project and replace it with Work that is not defective, and (iii) satisfactorily correct or repair or remove and replace any damage to other Work, to the work of others or other land or areas resulting therefrom. If CONTRACTOR does not promptly comply with the terms of such instructions, or in an emergency where delay would cause serious risk of loss or damage, OWNER may have the defective Work corrected or repaired or may have the rejected Work removed and replaced, and all Claims, costs, losses, and damages (including but not limited to all fees and charges of engineers, architects, attorneys, and other professionals and all court or arbitration or other dispute resolution costs) arising out of or relating to such correction or repair or such removal and replacement (including but not limited to all costs of repair or replacement of work of others) will be paid by CONTRACTOR.

B. In special circumstances where a particular item of equipment is placed in continuous service before Substantial Completion of all the Work, the correction period for that item may start to run from an earlier date if so provided in the Specifications or by Written Amendment.

C. Where defective Work (and damage to other Work resulting therefrom) has been corrected or removed and replaced under this paragraph 13.07, the correction period hereunder with respect to such Work will be extended for an additional period of one year after such correction or removal and replacement has been satisfactorily completed.

D. CONTRACTOR's obligations under this paragraph 13.07 are in addition to any other obligation or warranty. The provisions of this paragraph 13.07 shall not be construed as a substitute for or a waiver of the provisions of any applicable statute of limitation or repose.

#### 13.08 *Acceptance of Defective Work*

A. If, instead of requiring correction or removal and replacement of defective Work, OWNER (and, prior to ENGINEER's recommendation of final payment, ENGINEER) prefers to accept it, OWNER may do so. CONTRACTOR shall pay all Claims, costs, losses, and damages (including but not limited to all fees and charges of engineers, architects, attorneys, and other professionals and all court or arbitration or other dispute resolution costs) attributable to OWNER's evaluation of and determination to accept such defective Work (such costs to be approved by ENGINEER as to reasonableness) and the diminished value of the Work to the extent not otherwise paid by CONTRACTOR pursuant to this sentence. If any such acceptance occurs prior to ENGINEER's recommendation of final payment, a Change Order will be issued incorporating the necessary revisions in the Contract Documents with respect to the Work, and OWNER shall be entitled to an appropriate decrease in the Contract Price, reflecting the diminished value of Work so accepted. If the parties are unable to agree as to the amount thereof, OWNER may make a Claim therefor as provided in paragraph 10.05. If the acceptance occurs after such recommendation, an appropriate amount will be paid by CONTRACTOR to OWNER.

#### 13.09 *OWNER May Correct Defective Work*

A. If CONTRACTOR fails within a reasonable time after written notice from ENGINEER to correct defective Work or to remove and replace rejected Work as required by ENGINEER in accordance with paragraph 13.06.A, or if CONTRACTOR fails to perform the Work in accordance with the Contract Documents, or if CONTRACTOR fails to comply with any other provision of the Contract Documents, OWNER may, after seven days written notice

to CONTRACTOR, correct and remedy any such deficiency.

B. In exercising the rights and remedies under this paragraph, OWNER shall proceed expeditiously. In connection with such corrective and remedial action, OWNER may exclude CONTRACTOR from all or part of the Site, take possession of all or part of the Work and suspend CONTRACTOR's services related thereto, take possession of CONTRACTOR's tools, appliances, construction equipment and machinery at the Site, and incorporate in the Work all materials and equipment stored at the Site or for which OWNER has paid CONTRACTOR but which are stored elsewhere. CONTRACTOR shall allow OWNER, OWNER's representatives, agents and employees, OWNER's other contractors, and ENGINEER and ENGINEER's Consultants access to the Site to enable OWNER to exercise the rights and remedies under this paragraph.

C. All Claims, costs, losses, and damages (including but not limited to all fees and charges of engineers, architects, attorneys, and other professionals and all court or arbitration or other dispute resolution costs) incurred or sustained by OWNER in exercising the rights and remedies under this paragraph 13.09 will be charged against CONTRACTOR, and a Change Order will be issued incorporating the necessary revisions in the Contract Documents with respect to the Work; and OWNER shall be entitled to an appropriate decrease in the Contract Price. If the parties are unable to agree as to the amount of the adjustment, OWNER may make a Claim therefor as provided in paragraph 10.05. Such claims, costs, losses and damages will include but not be limited to all costs of repair, or replacement of work of others destroyed or damaged by correction, removal, or replacement of CONTRACTOR's defective Work.

D. CONTRACTOR shall not be allowed an extension of the Contract Times (or Milestones) because of any delay in the performance of the Work attributable to the exercise by OWNER of OWNER's rights and remedies under this paragraph 13.09.

ARTICLE 14 - PAYMENTS TO CONTRACTOR AND COMPLETION

---

14.01 *Schedule of Values*

A. The schedule of values established as provided in paragraph 2.07.A will serve as the basis for progress payments and will be incorporated into a form of Application for Payment acceptable to ENGINEER. Progress payments on account of Unit Price Work will be based on the number of units completed.

14.02 *Progress Payments*

A.\* *Applications for Payments*

1. At least 20 days before the date established for each progress payment (but not more often than once a month), CONTRACTOR shall submit to ENGINEER for review an Application for Payment filled out and signed by CONTRACTOR covering the Work completed as of the date of the Application and accompanied by such supporting documentation as is required by the Contract Documents. If payment is requested on the basis of materials and equipment not incorporated in the Work but delivered and suitably stored at the Site or at another location agreed to in writing, the Application for Payment shall also be accompanied by a bill of sale, invoice, or other documentation warranting that OWNER has received the materials and equipment free and clear of all Liens and evidence that the materials and equipment are covered by appropriate property insurance or other arrangements to protect OWNER's interest therein, all of which must be satisfactory to OWNER.

2. Beginning with the second Application for Payment, each Application shall include an affidavit of CONTRACTOR stating that all previous progress payments received on account of the Work have been applied on account to discharge CONTRACTOR's legitimate obligations associated with prior Applications for Payment.

3. The amount of retainage with respect to progress payments will be as stipulated in the Agreement.

\*See Supplementary Conditions

B. *Review of Applications*

1. ENGINEER will, within 10 days after receipt of each Application for Payment, either indicate in writing a recommendation of payment and present the Application to OWNER or return the Application to CONTRACTOR indicating in writing ENGINEER's reasons for refusing to recommend payment. In the latter case, CONTRACTOR may make the necessary corrections and resubmit the Application.

2. ENGINEER's recommendation of any payment requested in an Application for Payment will constitute a representation by ENGINEER to OWNER, based on ENGINEER's observations on the Site of the executed Work as an experienced and qualified design professional and on ENGINEER's review of the Application for Payment and the accompanying data and schedules, that to the best of ENGINEER's knowledge, information and belief:

a. the Work has progressed to the point indicated;

b. the quality of the Work is generally in accordance with the Contract Documents (subject to an evaluation of the Work as a functioning whole prior to or upon Substantial Completion, to the results of any subsequent tests called for in the Contract Documents, to a final determination of quantities and classifications for Unit Price Work under paragraph 9.08, and to any other qualifications stated in the recommendation); and

c. the conditions precedent to CONTRACTOR's being entitled to such payment appear to have been fulfilled in so far as it is ENGINEER's responsibility to observe the Work.

3. By recommending any such payment ENGINEER will not thereby be deemed to have represented that: (i) inspections made to check the quality or the quantity of the Work as it has been performed have been exhaustive, extended to every aspect of the Work in progress, or involved detailed inspections of the Work beyond the responsibilities specifically assigned to ENGINEER in the Contract Documents; or (ii) that there may not be other matters or issues between the parties

that might entitle CONTRACTOR to be paid additionally by OWNER or entitle OWNER to withhold payment to CONTRACTOR.

4. Neither ENGINEER's review of CONTRACTOR's Work for the purposes of recommending payments nor ENGINEER's recommendation of any payment, including final payment, will impose responsibility on ENGINEER to supervise, direct, or control the Work or for the means, methods, techniques, sequences, or procedures of construction, or the safety precautions and programs incident thereto, or for CONTRACTOR's failure to comply with Laws and Regulations applicable to CONTRACTOR's performance of the Work. Additionally, said review or recommendation will not impose responsibility on ENGINEER to make any examination to ascertain how or for what purposes CONTRACTOR has used the moneys paid on account of the Contract Price, or to determine that title to any of the Work, materials, or equipment has passed to OWNER free and clear of any Liens.

5. ENGINEER may refuse to recommend the whole or any part of any payment if, in ENGINEER's opinion, it would be incorrect to make the representations to OWNER referred to in paragraph 14.02.B.2. ENGINEER may also refuse to recommend any such payment or, because of subsequently discovered evidence or the results of subsequent inspections or tests, revise or revoke any such payment recommendation previously made, to such extent as may be necessary in ENGINEER's opinion to protect OWNER from loss because:

a. the Work is defective, or completed Work has been damaged, requiring correction or replacement;

b. the Contract Price has been reduced by Written Amendment or Change Orders;

c. OWNER has been required to correct defective Work or complete Work in accordance with paragraph 13.09; or

d. ENGINEER has actual knowledge of the occurrence of any of the events enumerated in paragraph 15.02.A.

#### C. *Payment Becomes Due*

1. Ten days after presentation of the Application for Payment to OWNER with ENGINEER's recommendation, the amount recommended will (subject to the provisions of paragraph 14.02.D) become due, and when due will be paid by OWNER to CONTRACTOR.

#### D. *Reduction in Payment*

1. OWNER may refuse to make payment of the full amount recommended by ENGINEER because:

a. claims have been made against OWNER on account of CONTRACTOR's performance or furnishing of the Work;

b. Liens have been filed in connection with the Work, except where CONTRACTOR has delivered a specific Bond satisfactory to OWNER to secure the satisfaction and discharge of such Liens;

c. there are other items entitling OWNER to a set-off against the amount recommended; or

d. OWNER has actual knowledge of the occurrence of any of the events enumerated in paragraphs 14.02.B.5.a through 14.02.B.5.c or paragraph 15.02.A.

2. If OWNER refuses to make payment of the full amount recommended by ENGINEER, OWNER must give CONTRACTOR immediate written notice (with a copy to ENGINEER) stating the reasons for such action and promptly pay CONTRACTOR any amount remaining after deduction of the amount so withheld. OWNER shall promptly pay CONTRACTOR the amount so withheld, or any adjustment thereto agreed to by OWNER and CONTRACTOR, when CONTRACTOR corrects to OWNER's satisfaction the reasons for such action.

3. If it is subsequently determined that OWNER's refusal of payment was not justified, the amount wrongfully withheld shall be treated as an amount due as determined by paragraph 14.02.C.1.

#### 14.03 *CONTRACTOR's Warranty of Title*

A. CONTRACTOR warrants and guarantees that title to all Work, materials, and equipment covered by any Application for Payment, whether incorporated in the Project or not, will pass to OWNER no later than the time of payment free and clear of all Liens.

#### 14.04 *Substantial Completion*

A. When CONTRACTOR considers the entire Work ready for its intended use CONTRACTOR shall notify OWNER and ENGINEER in writing that the entire Work is substantially complete (except for items specifically listed by CONTRACTOR as incomplete) and request that ENGINEER issue a certificate of Substantial Completion. Promptly thereafter, OWNER, CONTRACTOR, and ENGINEER shall make an inspection of the Work to determine the status of completion. If ENGINEER does not consider the Work substantially complete, ENGINEER will notify CONTRACTOR in writing giving the reasons therefor. If ENGINEER considers the Work substantially complete, ENGINEER will prepare and deliver to OWNER a tentative certificate of Substantial Completion which shall fix the date of Substantial Completion. There shall be attached to the certificate a tentative list of items to be completed or corrected before final payment. OWNER shall have seven days after receipt of the tentative certificate during which to make written objection to ENGINEER as to any provisions of the certificate or attached list. If, after considering such objections, ENGINEER concludes that the Work is not substantially complete, ENGINEER will within 14 days after submission of the tentative certificate to OWNER notify CONTRACTOR in writing, stating the reasons therefor. If, after consideration of OWNER's objections, ENGINEER considers the Work substantially complete, ENGINEER will within said 14 days execute and deliver to OWNER and CONTRACTOR a definitive certificate of Substantial Completion (with a revised tentative list of items to be completed or corrected) reflecting such changes from the tentative certificate as ENGINEER believes justified after consideration of any objections from OWNER. At the time of delivery of the tentative certificate of Substantial Completion ENGINEER will deliver to OWNER and CONTRACTOR a written recommendation as to division of responsibilities pending final payment between OWNER and CONTRACTOR with respect to security, operation, safety, and protection of the Work, maintenance, heat, utilities, insurance, and warranties and guarantees. Unless OWNER and CONTRACTOR agree otherwise in writing and so inform ENGINEER in writing prior to ENGINEER's issuing the definitive certificate of Substantial Completion,

ENGINEER's aforesaid recommendation will be binding on OWNER and CONTRACTOR until final payment.

B. OWNER shall have the right to exclude CONTRACTOR from the Site after the date of Substantial Completion, but OWNER shall allow CONTRACTOR reasonable access to complete or correct items on the tentative list.

#### 14.05 *Partial Utilization*

A. Use by OWNER at OWNER's option of any substantially completed part of the Work which has specifically been identified in the Contract Documents, or which OWNER, ENGINEER, and CONTRACTOR agree constitutes a separately functioning and usable part of the Work that can be used by OWNER for its intended purpose without significant interference with CONTRACTOR's performance of the remainder of the Work, may be accomplished prior to Substantial Completion of all the Work subject to the following conditions.

1. OWNER at any time may request CONTRACTOR in writing to permit OWNER to use any such part of the Work which OWNER believes to be ready for its intended use and substantially complete. If CONTRACTOR agrees that such part of the Work is substantially complete, CONTRACTOR will certify to OWNER and ENGINEER that such part of the Work is substantially complete and request ENGINEER to issue a certificate of Substantial Completion for that part of the Work. CONTRACTOR at any time may notify OWNER and ENGINEER in writing that CONTRACTOR considers any such part of the Work ready for its intended use and substantially complete and request ENGINEER to issue a certificate of Substantial Completion for that part of the Work. Within a reasonable time after either such request, OWNER, CONTRACTOR, and ENGINEER shall make an inspection of that part of the Work to determine its status of completion. If ENGINEER does not consider that part of the Work to be substantially complete, ENGINEER will notify OWNER and CONTRACTOR in writing giving the reasons therefor. If ENGINEER considers that part of the Work to be substantially complete, the provisions of paragraph 14.04 will apply with respect to certification of Substantial Completion of that part of the Work and the division of responsibility in respect thereof and access thereto.

2. No occupancy or separate operation of part of the Work may occur prior to compliance with the requirements of paragraph 5.10 regarding property insurance.

#### 14.06 *Final Inspection*

A. Upon written notice from CONTRACTOR that the entire Work or an agreed portion thereof is complete, ENGINEER will promptly make a final inspection with OWNER and CONTRACTOR and will notify CONTRACTOR in writing of all particulars in which this inspection reveals that the Work is incomplete or defective. CONTRACTOR shall immediately take such measures as are necessary to complete such Work or remedy such deficiencies.

#### 14.07 *Final Payment*

##### A. *Application for Payment*

1. After CONTRACTOR has, in the opinion of ENGINEER, satisfactorily completed all corrections identified during the final inspection and has delivered, in accordance with the Contract Documents, all maintenance and operating instructions, schedules, guarantees, Bonds, certificates or other evidence of insurance certificates of inspection, marked-up record documents (as provided in paragraph 6.12), and other documents, CONTRACTOR may make application for final payment following the procedure for progress payments.

2. The final Application for Payment shall be accompanied (except as previously delivered) by: (i) all documentation called for in the Contract Documents, including but not limited to the evidence of insurance required by subparagraph 5.04.B.7; (ii) consent of the surety, if any, to final payment; and (iii) complete and legally effective releases or waivers (satisfactory to OWNER) of all Lien rights arising out of or Liens filed in connection with the Work.

3. In lieu of the releases or waivers of Liens specified in paragraph 14.07.A.2 and as approved by OWNER, CONTRACTOR may furnish receipts or releases in full and an affidavit of CONTRACTOR that: (i) the releases and receipts include all labor, services, material, and equipment for which a Lien could be filed; and (ii) all payrolls, material and equipment bills, and other

indebtedness connected with the Work for which OWNER or OWNER's property might in any way be responsible have been paid or otherwise satisfied. If any Subcontractor or Supplier fails to furnish such a release or receipt in full, CONTRACTOR may furnish a Bond or other collateral satisfactory to OWNER to indemnify OWNER against any Lien.

##### B. *Review of Application and Acceptance*

1. If, on the basis of ENGINEER's observation of the Work during construction and final inspection, and ENGINEER's review of the final Application for Payment and accompanying documentation as required by the Contract Documents, ENGINEER is satisfied that the Work has been completed and CONTRACTOR's other obligations under the Contract Documents have been fulfilled, ENGINEER will, within ten days after receipt of the final Application for Payment, indicate in writing ENGINEER's recommendation of payment and present the Application for Payment to OWNER for payment. At the same time ENGINEER will also give written notice to OWNER and CONTRACTOR that the Work is acceptable subject to the provisions of paragraph 14.09. Otherwise, ENGINEER will return the Application for Payment to CONTRACTOR, indicating in writing the reasons for refusing to recommend final payment, in which case CONTRACTOR shall make the necessary corrections and resubmit the Application for Payment.

##### C. *Payment Becomes Due*

1. Thirty days after the presentation to OWNER of the Application for Payment and accompanying documentation, the amount recommended by ENGINEER will become due and, when due, will be paid by OWNER to CONTRACTOR.

#### 14.08 *Final Completion Delayed*

A. If, through no fault of CONTRACTOR, final completion of the Work is significantly delayed, and if ENGINEER so confirms, OWNER shall, upon receipt of CONTRACTOR's final Application for Payment and recommendation of ENGINEER, and without terminating the Agreement, make payment of the balance due for that portion of the Work fully completed and accepted. If the remaining balance to be held by OWNER for Work not

fully completed or corrected is less than the retainage stipulated in the Agreement, and if Bonds have been furnished as required in paragraph 5.01, the written consent of the surety to the payment of the balance due for that portion of the Work fully completed and accepted shall be submitted by CONTRACTOR to ENGINEER with the Application for such payment. Such payment shall be made under the terms and conditions governing final payment, except that it shall not constitute a waiver of Claims.

#### 14.09 *Waiver of Claims*

A. The making and acceptance of final payment will constitute:

1. a waiver of all Claims by OWNER against CONTRACTOR, except Claims arising from unsettled Liens, from defective Work appearing after final inspection pursuant to paragraph 14.06, from failure to comply with the Contract Documents or the terms of any special guarantees specified therein, or from CONTRACTOR's continuing obligations under the Contract Documents; and

2. a waiver of all Claims by CONTRACTOR against OWNER other than those previously made in writing which are still unsettled.

### ARTICLE 15 - SUSPENSION OF WORK AND TERMINATION

---

#### 15.01 *OWNER May Suspend Work*

A. At any time and without cause, OWNER may suspend the Work or any portion thereof for a period of not more than 90 consecutive days by notice in writing to CONTRACTOR and ENGINEER which will fix the date on which Work will be resumed. CONTRACTOR shall resume the Work on the date so fixed. CONTRACTOR shall be allowed an adjustment in the Contract Price or an extension of the Contract Times, or both, directly attributable to any such suspension if CONTRACTOR makes a Claim therefor as provided in paragraph 10.05.

#### 15.02 *OWNER May Terminate for Cause*

A. The occurrence of any one or more of the following events will justify termination for cause:

1. CONTRACTOR's persistent failure to perform the Work in accordance with the Contract Documents (including, but not limited to, failure to supply sufficient skilled workers or suitable materials or equipment or failure to adhere to the progress schedule established under paragraph 2.07 as adjusted from time to time pursuant to paragraph 6.04);

2. CONTRACTOR's disregard of Laws or Regulations of any public body having jurisdiction;

3. CONTRACTOR's disregard of the authority of ENGINEER; or

4. CONTRACTOR's violation in any substantial way of any provisions of the Contract Documents.

B. If one or more of the events identified in paragraph 15.02.A occur, OWNER may, after giving CONTRACTOR (and the surety, if any) seven days written notice, terminate the services of CONTRACTOR, exclude CONTRACTOR from the Site, and take possession of the Work and of all CONTRACTOR's tools, appliances, construction equipment, and machinery at the Site, and use the same to the full extent they could be used by CONTRACTOR (without liability to CONTRACTOR for trespass or conversion), incorporate in the Work all materials and equipment stored at the Site or for which OWNER has paid CONTRACTOR but which are stored elsewhere, and finish the Work as OWNER may deem expedient. In such case, CONTRACTOR shall not be entitled to receive any further payment until the Work is finished. If the unpaid balance of the Contract Price exceeds all claims, costs, losses, and damages (including but not limited to all fees and charges of engineers, architects, attorneys, and other professionals and all court or arbitration or other dispute resolution costs) sustained by OWNER arising out of or relating to completing the Work, such excess will be paid to CONTRACTOR. If such claims, costs, losses, and damages exceed such unpaid balance, CONTRACTOR shall pay the difference to OWNER. Such claims, costs, losses, and damages incurred by OWNER will be reviewed by ENGINEER as to their reasonableness and, when so approved by ENGINEER, incorporated in a Change Order. When exercising any rights or remedies under this paragraph OWNER shall not be required to obtain the lowest price for the Work performed.

C. Where CONTRACTOR's services have been so terminated by OWNER, the termination will not affect any rights or remedies of OWNER against CONTRACTOR then existing or which may thereafter accrue. Any retention or payment of moneys due CONTRACTOR by OWNER will not release CONTRACTOR from liability.

#### 15.03 *OWNER May Terminate For Convenience*

A. Upon seven days written notice to CONTRACTOR and ENGINEER, OWNER may, without cause and without prejudice to any other right or remedy of OWNER, elect to terminate the Contract. In such case, CONTRACTOR shall be paid (without duplication of any items):

1. for completed and acceptable Work executed in accordance with the Contract Documents prior to the effective date of termination, including fair and reasonable sums for overhead and profit on such Work;

2. for expenses sustained prior to the effective date of termination in performing services and furnishing labor, materials, or equipment as required by the Contract Documents in connection with uncompleted Work, plus fair and reasonable sums for overhead and profit on such expenses;

3. for all claims, costs, losses, and damages (including but not limited to all fees and charges of engineers, architects, attorneys, and other professionals and all court or arbitration or other dispute resolution costs) incurred in settlement of terminated contracts with Subcontractors, Suppliers, and others; and

4. for reasonable expenses directly attributable to termination.

B. CONTRACTOR shall not be paid on account of loss of anticipated profits or revenue or other economic loss arising out of or resulting from such termination.

#### 15.04 *CONTRACTOR May Stop Work or Terminate*

A. If, through no act or fault of CONTRACTOR, the Work is suspended for more than 90 consecutive days by OWNER or under an order of court or other public authority, or ENGINEER fails to act on any Application for Payment within 30 days after it is submitted, or OWNER fails for 30 days to pay CONTRACTOR any sum finally determined to be due, then CONTRACTOR may, upon

seven days written notice to OWNER and ENGINEER, and provided OWNER or ENGINEER do not remedy such suspension or failure within that time, terminate the Contract and recover from OWNER payment on the same terms as provided in paragraph 15.03. In lieu of terminating the Contract and without prejudice to any other right or remedy, if ENGINEER has failed to act on an Application for Payment within 30 days after it is submitted, or OWNER has failed for 30 days to pay CONTRACTOR any sum finally determined to be due, CONTRACTOR may, seven days after written notice to OWNER and ENGINEER, stop the Work until payment is made of all such amounts due CONTRACTOR, including interest thereon. The provisions of this paragraph 15.04 are not intended to preclude CONTRACTOR from making a Claim under paragraph 10.05 for an adjustment in Contract Price or Contract Times or otherwise for expenses or damage directly attributable to CONTRACTOR's stopping the Work as permitted by this paragraph.

#### ARTICLE 16 - DISPUTE RESOLUTION\*

##### 16.01 *Methods and Procedures*

A. Dispute resolution methods and procedures, if any, shall be as set forth in the Supplementary Conditions. If no method and procedure has been set forth, and subject to the provisions of paragraphs 9.09 and 10.05, OWNER and CONTRACTOR may exercise such rights or remedies as either may otherwise have under the Contract Documents or by Laws or Regulations in respect of any dispute.

#### ARTICLE 17 - MISCELLANEOUS\*

---

##### 17.01 *Giving Notice*

A. Whenever any provision of the Contract Documents requires the giving of written notice, it will be deemed to have been validly given if delivered in person to the individual or to a member of the firm or to an officer of the corporation for whom it is intended, or if delivered at or sent by registered or certified mail, postage prepaid, to the last business address known to the giver of the notice.

##### 17.02 *Computation of Times*

A. When any period of time is referred to in the Contract Documents by days, it will be computed to

exclude the first and include the last day of such period. If the last day of any such period falls on a Saturday or Sunday or on a day made a legal holiday by the law of the applicable jurisdiction, such day will be omitted from the computation.

17.03 *Cumulative Remedies*

A. The duties and obligations imposed by these General Conditions and the rights and remedies available hereunder to the parties hereto are in addition to, and are not to be construed in any way as a limitation of, any rights and remedies available to any or all of them which are otherwise imposed or available by Laws or Regulations, by special warranty or guarantee, or by other provisions of the Contract Documents, and the provisions of this paragraph will be as effective as if repeated specifically in the Contract Documents in connection with each particular duty, obligation, right, and remedy to which they apply.

17.04 *Survival of Obligations*

A. All representations, indemnifications, warranties, and guarantees made in, required by, or given in accordance with the Contract Documents, as well as all continuing obligations indicated in the Contract Documents, will survive final payment, completion, and acceptance of the Work or termination or completion of the Agreement.

17.05 *Controlling Law*

A. This Contract is to be governed by the law of the state in which the Project is located.

## SUPPLEMENTAL GENERAL CONDITIONS

These Supplementary Conditions amend or supplement the Standard General Conditions of the Construction Contract (No. 1910-8, 1996 Edition) and other provisions of the Contract Documents as indicated below. All provisions, which are not so amended or supplemental, remain in full force and effect.

The terms used in these Supplementary Conditions will have the meanings indicated in the General Conditions. Additional terms used in these Supplementary Conditions have the meanings indicated below, which are applicable to both the singular and plural thereof.

**SC-6.10** Delete paragraph 6.10 in its entirety and insert the following in its place:

*The owner qualifies for the state and local tax exemption in the purchase of certain materials and equipment the Contractor shall utilize the form provided herewith in exhibit "D".*

**SC-11.01** Delete paragraph 11.01 in its entirety.

**SC-11.02** Delete paragraph 11.02 in its entirety.

**SC-12.01B.25 & B.3.** Delete paragraph 12.01B.2 & B.3 in its entirety.

**SC-12.01.C.2** Delete paragraph 12.01.C.2 in its entirety.

**SC Article 14.02 C.1** Replace "**Ten days**" with "**Thirty days**" to read as follows: Thirty days after presentation of the Application for Payment to OWNER with ENGINEER'S recommendation, the amount recommended will (subject to the provisions of paragraph 14.02.D) become due, and when due will be paid by OWNER TO CONTRACTOR.

**SC Article 16** Add the following language at the end of the paragraph of Article 16:

*There are no dispute resolution methods and procedures set forth in the Supplemental Conditions:*

### GENERAL PREVAILING WAGE LEGAL REQUIREMENTS

The Contractor's attention is called to Texas Government Code Chapter 2258, which must be complied with attached herewith as Exhibit "C"

ITEM 247. Flexible Base

Flexible Base Type E will be composed of caliche (argillaceous Limestone, calcareous or calcareous clay particles) and may contain stone, conglomerate, gravel, sand or granular materials when these materials are in situ with the caliche.

Blended material for Flexible Base TY E GR 4

The Contractor may blend base material with another caliche source or with crushed concrete, meeting the requirements for TY "E" materials, provided a minimum of 50% caliche is used. The crushed concrete may contain sand or granular materials. Stabilizing additives will not be allowed in the raw crushed concrete base. Acceptance will be under the following conditions:

Condition One (1): When both components of the blend in their individual stockpiles meet all the physical requirements of this Item, then field blending will be allowed.

Condition Two (2): When only one component of the blend passes the physical requirements of this Item, the materials shall be blended through a plant for stockpile testing and approval.

Flexible Base (TY E GR 4) shall conform to the following requirements:

BEFORE LIME IS ADDED

Retained on Sq. Sieve	Percent Retained
2"	0
1/2"	20-60
No. 4	40-75
No. 40	70-90
Max. PI:	15
Max. Wet Ball PI:	15
Wet Ball Mill Max Amount:	50
Min. Comp. Strength PSI:	150 at 15 PSI lateral pressure
Triaxial Test	Tex-117-E

The Wet Ball Test (Tex-116-E) shall be run and the Plasticity Index of the material passing the No. 40 sieve shall be determined (Wet Ball PI).

After 1% lime (laboratory) is added to unlimed material

Max PI	12
Min. Comp. Strength PSI:	180 at 15 PSI Lateral Pressure
Triaxial Test (Lime Treated)	Tex-121-E

# **Technical Specifications**

## TECHNICAL SPECIFICATIONS

<u>ITEM</u>	<u>DESCRIPTION</u>
Item 247	Flexible Base
Item 341	Dense-Graded Hot-Mix Asphalt
Item 400	Excavation and Backfill for Structures
Item 402	Trench Excavation Protection
Item 464	Reinforced Concrete Pipe
Item 479	Adjusting Manholes and Inlets
Item 502	Barricades, Signs and Traffic Handling
Item 530	Driveways and Turnouts
Item 506	Temporary Erosion, Sedimentation and Environmental Controls

# Item 247

## Flexible Base



### 1. DESCRIPTION

Construct a foundation course composed of flexible base.

### 2. MATERIALS

Furnish uncontaminated materials of uniform quality that meet the requirements of the plans and specifications. Notify the Engineer of the proposed material sources and of changes to material sources. The Engineer may sample and test project materials at any time before compaction throughout the duration of the project to assure specification compliance. Use Tex-100-E material definitions.

- 2.1. **Aggregate.** Furnish aggregate of the type and grade shown on the plans and meeting the requirements of Table 1. Each source must meet Table 1 requirements for liquid limit, plasticity index, and wet ball mill for the grade specified. Do not use additives, such as but not limited to lime, cement, or fly ash to modify aggregates to meet the requirements of Table 1 unless shown on the plans.

Table 1  
Material Requirements

Property	Test Method	Grade 1-2	Grade 3	Grade 4 <sup>2</sup>	Grade 5
Master gradation sieve size (cumulative % retained)	Tex-110-E			As shown on the plans	
2-1/2"		0	0		0
1-3/4"		0-10	0-10		0-5
7/8"		10-35	-		10-35
3/8"		30-65	-		35-65
#4		45-75	45-75		45-75
#40	65-90	50-85	70-90		
Liquid Limit, % Max	Tex-104-E	40	40	As shown on the plans	35
Plasticity Index, Max <sup>1</sup>	Tex-106-E	10	12	As shown on the plans	10
Plasticity index, Min <sup>1</sup>		As shown on the plans	As shown on the plans	As shown on the plans	As shown on the plans
Wet ball mill, % Max	Tex-116-E	40	-	As shown on the plans	40
Wet ball mill, % Max increase passing the #40 sieve		20	-	As shown on the plans	20
Min compressive strength, psi	Tex-117-E			As shown on the plans	
lateral pressure 0 psi		35	-		-
lateral pressure 3 psi		-	-		90
lateral pressure 15 psi		175	-		175

- Determine plastic index in accordance with Tex-107-E (linear shrinkage) when liquid limit is unattainable as defined in Tex-104-E.
- Grade 4 may be further designated as Grade 4A, Grade 4B, etc.

- 2.1.1. **Material Tolerances.** The Engineer may accept material if no more than 1 of the 5 most recent gradation tests has an individual sieve outside the specified limits of the gradation.

When target grading is required by the plans, no single failing test may exceed the master grading by more than 5 percentage points on sieves No. 4 and larger or 3 percentage points on sieves smaller than No. 4.

The Engineer may accept material if no more than 1 of the 5 most recent plasticity index tests is outside the specified limit. No single failing test may exceed the allowable limit by more than 2 points.

- 2.1.2. **Material Types.** Do not use fillers or binders unless approved. Furnish the type specified on the plans in accordance with the following:
- 2.1.2.1. **Type A.** Crushed stone produced and graded from oversize quarried aggregate that originates from a single, naturally occurring source. Do not use gravel or multiple sources.
- 2.1.2.2. **Type B.** Crushed or uncrushed gravel. Blending of 2 or more sources is allowed.
- 2.1.2.3. **Type C.** Crushed gravel with a minimum of 60% of the particles retained on a No. 4 sieve with 2 or more crushed faces as determined by Tex-460-A, Part I. Blending of 2 or more sources is allowed.
- 2.1.2.4. **Type D.** Type A material or crushed concrete. Crushed concrete containing gravel will be considered Type D material. Crushed concrete must meet the requirements in Section 247.2.1.3.2., "Recycled Material (Including Crushed Concrete) Requirements," and be managed in a way to provide for uniform quality. The Engineer may require separate dedicated stockpiles in order to verify compliance.
- 2.1.2.5. **Type E.** Caliche, iron ore or as otherwise shown on the plans.
- 2.1.3. **Recycled Material.** Recycled asphalt pavement (RAP) and other recycled materials may be used when shown on the plans. Request approval to blend 2 or more sources of recycled materials.
- 2.1.3.1. **Limits on Percentage.** Do not exceed 20% RAP by weight, when RAP is allowed, unless otherwise shown on the plans. The percentage limitations for other recycled materials will be as shown on the plans.
- 2.1.3.2. **Recycled Material (Including Crushed Concrete) Requirements.**
- 2.1.3.2.1. **Contractor-Furnished Recycled Materials.** Provide recycled materials that have a maximum sulfate content of 3,000 ppm when tested in accordance with Tex-145-E. When the Contractor furnishes the recycled materials, including crushed concrete, the final product will be subject to the requirements of Table 1 for the grade specified. Certify compliance with DMS-11000, "Evaluating and Using Nonhazardous Recyclable Materials Guidelines," for Contractor furnished recycled materials. In addition, recycled materials must be free from reinforcing steel and other objectionable material and have at most 1.5% deleterious material when tested in accordance with Tex-413-A. For RAP, do not exceed a maximum percent loss from decantation of 5.0% when tested in accordance with Tex-406-A. Test RAP without removing the asphalt.
- 2.1.3.2.2. **Department-Furnished Required Recycled Materials.** When the Department furnishes and requires the use of recycled materials, unless otherwise shown on the plans:
- Department-required recycled material will not be subject to the requirements in Table 1,
  - Contractor-furnished materials are subject to the requirements in Table 1 and this Item,
  - the final product, blended, will be subject to the requirements in Table 1, and
  - for final product, unblended (100% Department-furnished required recycled material), the liquid limit, plasticity index, wet ball mill, and compressive strength is waived.
- Crush Department-furnished RAP so that 100% passes the 2 in. sieve. The Contractor is responsible for uniformly blending to meet the percentage required.
- 2.1.3.2.3. **Department-Furnished and Allowed Recycled Materials.** When the Department furnishes and allows the use of recycled materials or allows the Contractor to furnish recycled materials, the final blended product is subject to the requirements of Table 1 and the plans.
- 2.1.3.3. **Recycled Material Sources.** Department-owned recycled material is available to the Contractor only when shown on the plans. Return unused Department-owned recycled materials to the Department stockpile location designated by the Engineer unless otherwise shown on the plans.

The use of Contractor-owned recycled materials is allowed when shown on the plans. Contractor-owned surplus recycled materials remain the property of the Contractor. Remove Contractor-owned recycled materials from the project and dispose of them in accordance with federal, state, and local regulations before project acceptance. Do not intermingle Contractor-owned recycled material with Department-owned recycled material unless approved.

- 2.2. **Water.** Furnish water free of industrial wastes and other objectionable matter.
- 2.3. **Material Sources.** Expose the vertical faces of all strata of material proposed for use when non-commercial sources are used. Secure and process the material by successive vertical cuts extending through all exposed strata, when directed.

---

### 3. EQUIPMENT

Provide machinery, tools, and equipment necessary for proper execution of the work.

- 3.1. Provide rollers in accordance with Item 210, "Rolling." Provide proof rollers in accordance with Item 216, "Proof Rolling," when required.
- 3.2. When ride quality measurement is required, provide a high speed or lightweight inertial profiler certified at the Texas A&M Transportation Institute. Provide equipment certification documentation. Display a current decal on the equipment indicating the certification expiration date.

---

### 4. CONSTRUCTION

Construct each layer uniformly, free of loose or segregated areas, and with the required density and moisture content. Provide a smooth surface that conforms to the typical sections, lines, and grades shown on the plans or as directed.

Stockpile base material temporarily at an approved location before delivery to the roadway. Build stockpiles in layers no greater than 2 ft. thick. Stockpiles must have a total height between 10 and 16 ft. unless otherwise shown on the plans. After construction and acceptance of the stockpile, loading from the stockpile for delivery is allowed. Load by making successive vertical cuts through the entire depth of the stockpile.

Do not add or remove material from temporary stockpiles that require sampling and testing before delivery unless otherwise approved. Charges for additional sampling and testing required as a result of adding or removing material will be deducted from the Contractor's estimates.

Haul approved flexible base in clean trucks. Deliver the required quantity to each 100-ft. station or designated stockpile site as shown on the plans. Prepare stockpile sites as directed. When delivery is to the 100-ft. station, manipulate in accordance with the applicable Items.

- 4.1. **Preparation of Subgrade or Existing Base.** Remove or scarify existing asphalt concrete pavement in accordance with Item 105, "Removing Treated and Untreated Base and Asphalt Pavement," when shown on the plans or as directed. Shape the subgrade or existing base to conform to the typical sections shown on the plans or as directed.

When new base is required to be mixed with existing base, deliver, place, and spread the new flexible base in the required amount per station. Manipulate and thoroughly mix the new base with existing material to provide a uniform mixture to the specified depth before shaping.

Proof roll the roadbed in accordance with Item 216, "Proof Rolling," before pulverizing or scarifying when shown on the plans or directed. Correct soft spots as directed.

- 4.2. **Placing.** Spread and shape flexible base into a uniform layer with an approved spreader the same day as delivered unless otherwise approved. Construct layers to the thickness shown on the plans. Maintain the

shape of the course. Control dust by sprinkling, as directed. Correct or replace segregated areas as directed, at no additional expense to the Department.

Place successive base courses and finish courses using the same construction methods required for the first course.

- 4.3. **Compaction.** Compact using density control unless otherwise shown on the plans. Multiple lifts are permitted when shown on the plans or approved. Bring each layer to the moisture content directed. When necessary, sprinkle the material in accordance with Item 204, "Sprinkling."

Begin rolling longitudinally at the sides and proceed towards the center, overlapping on successive trips by at least 1/2 the width of the roller unit. Begin rolling at the low side and progress toward the high side on superelevated curves. Offset alternate trips of the roller. Operate rollers at a speed between 2 and 6 mph as directed.

Rework, recompact, and refinish material that fails to meet or that loses required moisture, density, stability, or finish requirements before the next course is placed or the project is accepted. Continue work until specification requirements are met. Perform the work at no additional expense to the Department.

Before final acceptance, the Engineer will select the locations of tests and measure the flexible base depth in accordance with Tex-140-E. Correct areas deficient by more than 1/2 in. in thickness by scarifying, adding material as required, reshaping, recompacting, and refinishing at the Contractor's expense.

- 4.3.1. **Ordinary Compaction.** Roll with approved compaction equipment as directed. Correct irregularities, depressions, and weak spots immediately by scarifying the areas affected, adding or removing approved material as required, reshaping, and recompacting.

- 4.3.2. **Density Control.** Compact to at least 100% of the maximum dry density determined by Tex-113-E, unless otherwise shown on the plans. Maintain moisture during compaction within  $\pm 2$  percentage points of the optimum moisture content as determined by Tex-113-E. Measure the moisture content of the material in accordance with Tex-115-E or Tex-103-E during compaction daily and report the results the same day to the Engineer, unless otherwise shown on the plans or directed. Do not achieve density by drying the material after compaction.

The Engineer will determine roadway density and moisture content of completed sections in accordance with Tex-115-E. The Engineer may accept the section if no more than 1 of the 5 most recent density tests is below the specified density and the failing test is no more than 3 pcf below the specified density.

- 4.4. **Finishing.** After completing compaction, clip, skin, or tight-blade the surface with a maintainer or subgrade trimmer to a depth of approximately 1/4 in. Remove loosened material and dispose of it at an approved location. Seal the clipped surface immediately by rolling with a pneumatic tire roller until a smooth surface is attained. Add small increments of water as needed during rolling. Shape and maintain the course and surface in conformity with the typical sections, lines, and grades as shown on the plans or as directed.

Correct grade deviations greater than 1/4 in. in 16 feet measured longitudinally or greater than 1/4 in. over the entire width of the cross-section in areas where surfacing is to be placed. Correct by loosening and adding, or removing material. Reshape and re-compact in accordance with Section 247.4.3., "Compaction."

- 4.5. **Curing.** Cure the finished section until the moisture content is at least 2 percentage points below optimum or as directed before applying the next successive course or prime coat.

- 4.6. **Ride Quality.** This section applies to the final travel lanes that receive a 1 or 2 course surface treatment for the final surface, unless otherwise shown on the plans. Measure ride quality of the base course after placement of the prime coat and before placement of the surface treatment, unless otherwise approved. Use a certified profiler operator from the Department's MPL. When requested, furnish the Engineer documentation for the person certified to operate the profiler.

Provide all profile measurements to the Engineer in electronic data files within 3 days after placement of the prime coat using the format specified in Tex-1001-S. The Engineer will use Department software to evaluate longitudinal profiles to determine areas requiring corrective action. Correct 0.1-mi.sections having an average international roughness index (IRI) value greater than 100.0 in. per mile to an IRI value of 100.0 in. per mile or less for each wheelpath, unless otherwise shown on the plans.

Re-profile and correct sections that fail to maintain ride quality until placement of the next course, as directed. Correct re-profiled sections until specification requirements are met, as approved. Perform this work at no additional expense to the Department.

---

## 5. MEASUREMENT

Flexible base will be measured as follows:

- **Flexible Base (Complete In Place).** The ton, square yard, or any cubic yard method.
- **Flexible Base (Roadway Delivery).** The ton or any cubic yard method.
- **Flexible Base (Stockpile Delivery).** The ton, cubic yard in vehicle, or cubic yard in stockpile.

Measurement by the cubic yard in final position and square yard is a plans quantity measurement. The quantity to be paid for is the quantity shown in the proposal unless modified by Article 9.2., "Plans Quantity Measurement." Additional measurements or calculations will be made if adjustments of quantities are required.

Measurement is further defined for payment as follows.

- 5.1. **Cubic Yard in Vehicle.** By the cubic yard in vehicles of uniform capacity at the point of delivery.
- 5.2. **Cubic Yard in Stockpile.** By the cubic yard in the final stockpile position by the method of average end areas.
- 5.3. **Cubic Yard in Final Position.** By the cubic yard in the completed and accepted final position. The volume of base course is computed in place by the method of average end areas between the original subgrade or existing base surfaces and the lines, grades, and slopes of the accepted base course as shown on the plans.
- 5.4. **Square Yard.** By the square yard of surface area in the completed and accepted final position. The surface area of the base course is based on the width of flexible base as shown on the plans.
- 5.5. **Ton.** By the ton of dry weight in vehicles as delivered. The dry weight is determined by deducting the weight of the moisture in the material at the time of weighing from the gross weight of the material. The Engineer will determine the moisture content in the material in accordance with Tex-103-E from samples taken at the time of weighing.

When material is measured in trucks, the weight of the material will be determined on certified scales, or the Contractor must provide a set of standard platform truck scales at a location approved by the Engineer. Scales must conform to the requirements of Item 520, "Weighing and Measuring Equipment."

---

## 6. PAYMENT

The work performed and materials furnished in accordance with this Item and measured as provided under "Measurement" will be paid for at the unit price bid for the types of work shown below. No additional payment will be made for thickness or width exceeding that shown on the typical section or provided on the plans for cubic yard in the final position or square yard measurement.

Sprinkling and rolling, except proof rolling, will not be paid for directly but will be subsidiary to this Item unless otherwise shown on the plans. When proof rolling is shown on the plans or directed, it will be paid for in accordance with Item 216, "Proof Rolling."

Where subgrade is constructed under this Contract, correction of soft spots in the subgrade will be at the Contractor's expense. Where subgrade is not constructed under this Contract, correction of soft spots in the subgrade will be paid in accordance with pertinent Items or Article 4.4., "Changes in the Work."

- 6.1. **Flexible Base (Complete In Place).** Payment will be made for the type and grade specified. For cubic yard measurement, "In Vehicle," "In Stockpile," or "In Final Position" will be specified. For square yard measurement, a depth will be specified. This price is full compensation for furnishing materials, temporary stockpiling, assistance provided in stockpile sampling and operations to level stockpiles for measurement, loading, hauling, delivery of materials, spreading, blading, mixing, shaping, placing, compacting, reworking, finishing, correcting locations where thickness is deficient, curing, furnishing scales and labor for weighing and measuring, and equipment, labor, tools, and incidentals.
- 6.2. **Flexible Base (Roadway Delivery).** Payment will be made for the type and grade specified. For cubic yard measurement, "In Vehicle," "In Stockpile," or "In Final Position" will be specified. The unit price bid will not include processing at the roadway. This price is full compensation for furnishing materials, temporary stockpiling, assistance provided in stockpile sampling and operations to level stockpiles for measurement, loading, hauling, delivery of materials, furnishing scales and labor for weighing and measuring, and equipment, labor, tools, and incidentals.
- 6.3. **Flexible Base (Stockpile Delivery).** Payment will be made for the type and grade specified. For cubic yard measurement, "In Vehicle" or "In Stockpile" will be specified. The unit price bid will not include processing at the roadway. This price is full compensation for furnishing and disposing of materials, preparing the stockpile area, temporary or permanent stockpiling, assistance provided in stockpile sampling and operations to level stockpiles for measurement, loading, hauling, delivery of materials to the stockpile, furnishing scales and labor for weighing and measuring, and equipment, labor, tools, and incidentals.

## Item 341

# Dense-Graded Hot-Mix Asphalt



### 1. DESCRIPTION

Construct a hot-mix asphalt (HMA) pavement layer composed of a compacted, dense-graded mixture of aggregate and asphalt binder mixed hot in a mixing plant. Pay adjustments will apply to HMA placed under this specification unless the HMA is deemed exempt in accordance with Section 341.4.9.4., "Exempt Production."

### 2. MATERIALS

Furnish uncontaminated materials of uniform quality that meet the requirements of the plans and specifications.

Notify the Engineer of all material sources and before changing any material source or formulation. The Engineer will verify that the specification requirements are met when the Contractor makes a source or formulation change, and may require a new laboratory mixture design, trial batch, or both. The Engineer may sample and test project materials at any time during the project to verify specification compliance in accordance with Item 6, "Control of Materials."

- 2.1. **Aggregate.** Furnish aggregates from sources that conform to the requirements shown in Table 1 and as specified in this Section. Aggregate requirements in this Section, including those shown in Table 1, may be modified or eliminated when shown on the plans. Additional aggregate requirements may be specified when shown on the plans. Provide aggregate stockpiles that meet the definitions in this Section for coarse, intermediate, or fine aggregate. Aggregate from reclaimed asphalt pavement (RAP) is not required to meet Table 1 requirements unless otherwise shown on the plans. Supply aggregates that meet the definitions in Tex-100-E for crushed gravel or crushed stone. The Engineer will designate the plant or the quarry as the sampling location. Provide samples from materials produced for the project. The Engineer will establish the Surface Aggregate Classification (SAC) and perform Los Angeles abrasion, magnesium sulfate soundness, and Micro-Deval tests. Perform all other aggregate quality tests listed in Table 1. Document all test results on the mixture design report. The Engineer may perform tests on independent or split samples to verify Contractor test results. Stockpile aggregates for each source and type separately. Determine aggregate gradations for mixture design and production testing based on the washed sieve analysis given in Tex-200-F, Part II.

- 2.1.1. **Coarse Aggregate.** Coarse aggregate stockpiles must have no more than 20% material passing the No. 8 sieve. Aggregates from sources listed in the Department's *Bituminous Rated Source Quality Catalog* (BRSQC) are preapproved for use. Use only the rated values for hot-mix listed in the BRSQC. Rated values for surface treatment (ST) do not apply to coarse aggregate sources used in hot-mix asphalt.

For sources not listed on the Department's BRSQC:

- build an individual stockpile for each material;
- request the Department test the stockpile for specification compliance; and
- once approved, do not add material to the stockpile unless otherwise approved.

Provide aggregate from non-listed sources only when tested by the Engineer and approved before use. Allow 30 calendar days for the Engineer to sample, test, and report results for non-listed sources.

Provide coarse aggregate with at least the minimum SAC shown on the plans. SAC requirements only apply to aggregates used on the surface of travel lanes. SAC requirements apply to aggregates used on surfaces

other than travel lanes when shown on the plans. The SAC for sources on the Department's *Aggregate Quality Monitoring Program (AQMP)* (Tex-499-A) is listed in the BRSQC.

- 2.1.1.1. **Blending Class A and Class B Aggregates.** Class B aggregate meeting all other requirements in Table 1 may be blended with a Class A aggregate to meet requirements for Class A materials. Ensure that at least 50% by weight, or volume if required, of the material retained on the No. 4 sieve comes from the Class A aggregate source when blending Class A and B aggregates to meet a Class A requirement. Blend by volume if the bulk specific gravities of the Class A and B aggregates differ by more than 0.300. Coarse aggregate from RAP and Recycled Asphalt Shingles (RAS) will be considered as Class B aggregate for blending purposes.

The Engineer may perform tests at any time during production, when the Contractor blends Class A and B aggregates to meet a Class A requirement, to ensure that at least 50% by weight, or volume if required, of the material retained on the No. 4 sieve comes from the Class A aggregate source. The Engineer will use the Department's mix design Excel template, when electing to verify conformance, to calculate the percent of Class A aggregate retained on the No. 4 sieve by inputting the bin percentages shown from readouts in the control room at the time of production and stockpile gradations measured at the time of production. The Engineer may determine the gradations based on either washed or dry sieve analysis from samples obtained from individual aggregate cold feed bins or aggregate stockpiles. The Engineer may perform spot checks using the gradations supplied by the Contractor on the mixture design report as an input for the Excel template; however, a failing spot check will require confirmation with a stockpile gradation determined by the Engineer.

- 2.1.1.2. **Micro-Deval Abrasion.** The Engineer will perform a minimum of one Micro-Deval abrasion test in accordance with Tex-461-A for each coarse aggregate source used in the mixture design that has a Rated Source Soundness Magnesium (RSSM) loss value greater than 15 as listed in the BRSQC. The Engineer will perform testing before the start of production and may perform additional testing at any time during production. The Engineer may obtain the coarse aggregate samples from each coarse aggregate source or may require the Contractor to obtain the samples. The Engineer may waive all Micro-Deval testing based on a satisfactory test history of the same aggregate source.

The Engineer will estimate the magnesium sulfate soundness loss for each coarse aggregate source, when tested, using the following formula:

$$Mg_{est.} = (RSSM)(MD_{act.}/RSMD)$$

where:

$Mg_{est.}$  = magnesium sulfate soundness loss

$MD_{act.}$  = actual Micro-Deval percent loss

$RSMD$  = Rated Source Micro-Deval

When the estimated magnesium sulfate soundness loss is greater than the maximum magnesium sulfate soundness loss specified, the coarse aggregate source will not be allowed for use unless otherwise approved. The Engineer will consult the Geotechnical, Soils, and Aggregates Branch of the Construction Division, and additional testing may be required before granting approval.

- 2.1.2. **Intermediate Aggregate.** Aggregates not meeting the definition of coarse or fine aggregate will be defined as intermediate aggregate. Supply intermediate aggregates, when used, that are free from organic impurities. The Engineer may test the intermediate aggregate in accordance with Tex-408-A to verify the material is free from organic impurities. Supply intermediate aggregate from coarse aggregate sources, when used, that meet the requirements shown in Table 1 unless otherwise approved.

Test the stockpile if 10% or more of the stockpile is retained on the No. 4 sieve, and verify that it meets the requirements in Table 1 for crushed face count (Tex-460-A) and flat and elongated particles (Tex-280-F).

- 2.1.3. **Fine Aggregate.** Fine aggregates consist of manufactured sands, screenings, and field sands. Fine aggregate stockpiles must meet the gradation requirements in Table 2. Supply fine aggregates that are free

from organic impurities. The Engineer may test the fine aggregate in accordance with Tex-408-A to verify the material is free from organic impurities. No more than 15% of the total aggregate may be field sand or other uncrushed fine aggregate. Use fine aggregate, with the exception of field sand, from coarse aggregate sources that meet the requirements shown in Table 1 unless otherwise approved.

Test the stockpile if 10% or more of the stockpile is retained on the No. 4 sieve and verify that it meets the requirements in Table 1 for crushed face count (Tex-460-A) and flat and elongated particles (Tex-280-F).

**Table 1**  
**Aggregate Quality Requirements**

Property	Test Method	Requirement
<b>Coarse Aggregate</b>		
SAC	Tex-499-A (AQMP)	As shown on the plans
Deleterious material, %, Max	Tex-217-F, Part I	1.5
Decantation, %, Max	Tex-217-F, Part II	1.5
Micro-Deval abrasion, %	Tex-461-A	Note <sup>1</sup>
Los Angeles abrasion, %, Max	Tex-410-A	40
Magnesium sulfate soundness, 5 cycles, %, Max	Tex-411-A	30
Crushed face count, <sup>2</sup> %, Min	Tex-460-A, Part I	85
Flat and elongated particles @ 5:1, %, Max	Tex-280-F	10
<b>Fine Aggregate</b>		
Linear shrinkage, %, Max	Tex-107-E	3
<b>Combined Aggregate<sup>3</sup></b>		
Sand equivalent, %, Min	Tex-203-F	45

1. Used to estimate the magnesium sulfate soundness loss in accordance with Section 341.2.1.1.2., "Micro-Deval Abrasion."
2. Only applies to crushed gravel.
3. Aggregates, without mineral filler, RAP, RAS, or additives, combined as used in the job-mix formula (JMF).

**Table 2**  
**Gradation Requirements for Fine Aggregate**

Sieve Size	% Passing by Weight or Volume
3/8"	100
#8	70-100
#200	0-30

- 2.2. **Mineral Filler.** Mineral filler consists of finely divided mineral matter such as agricultural lime, crusher fines, hydrated lime, or fly ash. Mineral filler is allowed unless otherwise shown on the plans. Use no more than 2% hydrated lime or fly ash unless otherwise shown on the plans. Use no more than 1% hydrated lime if a substitute binder is used unless otherwise shown on the plans or allowed. Test all mineral fillers except hydrated lime and fly ash in accordance with Tex-107-E to ensure specification compliance. The plans may require or disallow specific mineral fillers. Provide mineral filler, when used, that:

- is sufficiently dry, free-flowing, and free from clumps and foreign matter as determined by the Engineer;
- does not exceed 3% linear shrinkage when tested in accordance with Tex-107-E; and
- meets the gradation requirements in Table 3.

**Table 3**  
**Gradation Requirements for Mineral Filler**

Sieve Size	% Passing by Weight or Volume
#8	100
#200	55-100

- 2.3. **Baghouse Fines.** Fines collected by the baghouse or other dust-collecting equipment may be reintroduced into the mixing drum.
- 2.4. **Asphalt Binder.** Furnish the type and grade of performance-graded (PG) asphalt specified on the plans.

- 2.5. **Tack Coat.** Furnish CSS-1H, SS-1H, or a PG binder with a minimum high-temperature grade of PG 58 for tack coat binder in accordance with Item 300, "Asphalts, Oils, and Emulsions." Specialized or preferred tack coat materials may be allowed or required when shown on the plans. Do not dilute emulsified asphalts at the terminal, in the field, or at any other location before use.

The Engineer will obtain at least one sample of the tack coat binder per project in accordance with Tex-500-C, Part III, and test it to verify compliance with Item 300, "Asphalts, Oils, and Emulsions." The Engineer will obtain the sample from the asphalt distributor immediately before use.

- 2.6. **Additives.** Use the type and rate of additive specified when shown on the plans. Additives that facilitate mixing, compaction, or improve the quality of the mixture are allowed when approved. Provide the Engineer with documentation such as the bill of lading showing the quantity of additives used in the project unless otherwise directed.
- 2.6.1. **Lime and Liquid Antistripping Agent.** When lime or a liquid antistripping agent is used, add in accordance with Item 301, "Asphalt Antistripping Agents." Do not add lime directly into the mixing drum of any plant where lime is removed through the exhaust stream unless the plant has a baghouse or dust collection system that reintroduces the lime into the drum.
- 2.6.2. **Warm Mix Asphalt (WMA).** Warm Mix Asphalt (WMA) is defined as HMA that is produced within a target temperature discharge range of 215°F and 275°F using approved WMA additives or processes from the Department's MPL.

WMA is allowed for use on all projects and is required when shown on the plans. When WMA is required, the maximum placement or target discharge temperature for WMA will be set at a value below 275°F.

Department-approved WMA additives or processes may be used to facilitate mixing and compaction of HMA produced at target discharge temperatures above 275°F; however, such mixtures will not be defined as WMA.

- 2.7. **Recycled Materials.** Use of RAP and RAS is permitted unless otherwise shown on the plans. Do not exceed the maximum allowable percentages of RAP and RAS shown in Table 4. The allowable percentages shown in Table 4 may be decreased or increased when shown on the plans. Determine asphalt binder content and gradation of the RAP and RAS stockpiles for mixture design purposes in accordance with Tex-236-F. The Engineer may verify the asphalt binder content of the stockpiles at any time during production. Perform other tests on RAP and RAS when shown on the plans. Asphalt binder from RAP and RAS is designated as recycled asphalt binder. Calculate and ensure that the ratio of the recycled asphalt binder to total binder does not exceed the percentages shown in Table 5 during mixture design and HMA production when RAP or RAS is used. Use a separate cold feed bin for each stockpile of RAP and RAS during HMA production.

Surface, intermediate, and base mixes referenced in Tables 4 and 5 are defined as follows:

- **Surface.** The final HMA lift placed at or near the top of the pavement structure;
- **Intermediate.** Mixtures placed below an HMA surface mix and less than or equal to 8.0 in. from the riding surface; and
- **Base.** Mixtures placed greater than 8.0 in. from the riding surface.

- 2.7.1. **RAP.** RAP is salvaged, milled, pulverized, broken, or crushed asphalt pavement. Crush or break RAP so that 100% of the particles pass the 2 in. sieve. Fractionated RAP is defined as 2 or more RAP stockpiles, divided into coarse and fine fractions.

Use of Contractor-owned RAP including HMA plant waste is permitted unless otherwise shown on the plans. Department-owned RAP stockpiles are available for the Contractor's use when the stockpile locations are shown on the plans. If Department-owned RAP is available for the Contractor's use, the Contractor may use Contractor-owned fractionated RAP and replace it with an equal quantity of Department-owned RAP. This allowance does not apply to a Contractor using unfractionated RAP. Department-owned RAP generated through required work on the Contract is available for the Contractor's use when shown on the plans.

Perform any necessary tests to ensure Contractor- or Department-owned RAP is appropriate for use. The Department will not perform any tests or assume any liability for the quality of the Department-owned RAP unless otherwise shown on the plans. The Contractor will retain ownership of RAP generated on the project when shown on the plans.

The coarse RAP stockpile will contain only material retained by processing over a 3/8-in. or 1/2-in. screen unless otherwise approved. The fine RAP stockpile will contain only material passing the 3/8-in. or 1/2-in. screen unless otherwise approved. The Engineer may allow the Contractor to use an alternate to the 3/8-in. or 1/2-in. screen to fractionate the RAP. The maximum percentages of fractionated RAP may be comprised of coarse or fine fractionated RAP or the combination of both coarse and fine fractionated RAP.

Do not use Department- or Contractor-owned RAP contaminated with dirt or other objectionable materials. Do not use Department- or Contractor-owned RAP if the decantation value exceeds 5% and the plasticity index is greater than 8. Test the stockpiled RAP for decantation in accordance with Tex-406-A, Part I. Determine the plasticity index in accordance with Tex-106-E if the decantation value exceeds 5%. The decantation and plasticity index requirements do not apply to RAP samples with asphalt removed by extraction or ignition.

Do not intermingle Contractor-owned RAP stockpiles with Department-owned RAP stockpiles. Remove unused Contractor-owned RAP material from the project site upon completion of the project. Return unused Department-owned RAP to the designated stockpile location.

**Table 4**  
**Maximum Allowable Amounts of RAP<sup>1</sup>**

Maximum Allowable Fractionated RAP <sup>2</sup> (%)			Maximum Allowable Unfractionated RAP <sup>3</sup> (%)		
Surface	Intermediate	Base	Surface	Intermediate	Base
20.0	30.0	40.0	10.0	10.0	10.0

1. Must also meet the recycled binder to total binder ratio shown in Table 5.
2. Up to 5% RAS may be used separately or as a replacement for fractionated RAP.
3. Unfractionated RAP may not be combined with fractionated RAP or RAS.

#### 2.7.2.

**RAS.** Use of post-manufactured RAS or post-consumer RAS (tear-offs) is permitted unless otherwise shown on the plans. Up to 5% RAS may be used separately or as a replacement for fractionated RAP in accordance with Table 4 and Table 5. RAS is defined as processed asphalt shingle material from manufacturing of asphalt roofing shingles or from re-roofing residential structures. Post-manufactured RAS is processed manufacturer's shingle scrap by-product. Post-consumer RAS is processed shingle scrap removed from residential structures. Comply with all regulatory requirements stipulated for RAS by the TCEQ. RAS may be used separately or in conjunction with RAP.

Process the RAS by ambient grinding or granulating such that 100% of the particles pass the 3/8 in. sieve when tested in accordance with Tex-200-F, Part I. Perform a sieve analysis on processed RAS material before extraction (or ignition) of the asphalt binder.

Add sand meeting the requirements of Table 1 and Table 2 or fine RAP to RAS stockpiles if needed to keep the processed material workable. Any stockpile that contains RAS will be considered a RAS stockpile and be limited to no more than 5.0% of the HMA mixture in accordance with Table 4.

Certify compliance of the RAS with DMS-11000, "Evaluating and Using Nonhazardous Recyclable Materials Guidelines." Treat RAS as an established nonhazardous recyclable material if it has not come into contact with any hazardous materials. Use RAS from shingle sources on the Department's MPL. Remove substantially all materials before use that are not part of the shingle, such as wood, paper, metal, plastic, and felt paper. Determine the deleterious content of RAS material for mixture design purposes in accordance with Tex-217-F, Part III. Do not use RAS if deleterious materials are more than 0.5% of the stockpiled RAS unless otherwise approved. Submit a sample for approval before submitting the mixture design. The Department will perform the testing for deleterious material of RAS to determine specification compliance.

2.8. **Substitute Binders.** Unless otherwise shown on the plans, the Contractor may use a substitute PG binder listed in Table 5 instead of the PG binder originally specified, if the substitute PG binder and mixture made with the substitute PG binder meet the following:

- the substitute binder meets the specification requirements for the substitute binder grade in accordance with Section 300.2.10., "Performance-Graded Binders"; and
- the mixture has less than 10.0 mm of rutting on the Hamburg Wheel test (Tex-242-F) after the number of passes required for the originally specified binder. Use of substitute PG binders may only be allowed at the discretion of the Engineer if the Hamburg Wheel test results are between 10.0 mm and 12.5 mm.

**Table 5**  
**Allowable Substitute PG Binders and Maximum Recycled Binder Ratios**

Originally Specified PG Binder	Allowable Substitute PG Binder	Maximum Ratio of Recycled Binder <sup>1</sup> to Total Binder (%)		
		Surface	Intermediate	Base
<b>HMA</b>				
76-22 <sup>2</sup>	70-22 or 64-22	20.0	20.0	20.0
	70-28 or 64-28	30.0	35.0	40.0
70-22 <sup>2</sup>	64-22	20.0	20.0	20.0
	64-28 or 58-28	30.0	35.0	40.0
64-22 <sup>2</sup>	58-28	30.0	35.0	40.0
76-28 <sup>2</sup>	70-28 or 64-28	20.0	20.0	20.0
	64-34	30.0	35.0	40.0
70-28 <sup>2</sup>	64-28 or 58-28	20.0	20.0	20.0
	64-34 or 58-34	30.0	35.0	40.0
64-28 <sup>2</sup>	58-28	20.0	20.0	20.0
	58-34	30.0	35.0	40.0
<b>WMA<sup>3</sup></b>				
76-22 <sup>2</sup>	70-22 or 64-22	30.0	35.0	40.0
70-22 <sup>2</sup>	64-22 or 58-28	30.0	35.0	40.0
64-22 <sup>4</sup>	58-28	30.0	35.0	40.0
76-28 <sup>2</sup>	70-28 or 64-28	30.0	35.0	40.0
70-28 <sup>2</sup>	64-28 or 58-28	30.0	35.0	40.0
64-28 <sup>4</sup>	58-28	30.0	35.0	40.0

1. Combined recycled binder from RAP and RAS.
2. Use no more than 20.0% recycled binder when using this originally specified PG binder.
3. WMA as defined in Section 341.2.6.2., "Warm Mix Asphalt (WMA)."
4. When used with WMA, this originally specified PG binder is allowed for use at the maximum recycled binder ratios shown in this table.

### 3. EQUIPMENT

Provide required or necessary equipment in accordance with Item 320, "Equipment for Asphalt Concrete Pavement."

### 4. CONSTRUCTION

Produce, haul, place, and compact the specified paving mixture. In addition to tests required by the specification, Contractors may perform other QC tests as deemed necessary. At any time during the project, the Engineer may perform production and placement tests as deemed necessary in accordance with Item 5, "Control of the Work." Schedule and participate in a mandatory pre-paving meeting with the Engineer on or before the first day of paving unless otherwise shown on the plans.

- 4.1. **Certification.** Personnel certified by the Department-approved hot-mix asphalt certification program must conduct all mixture designs, sampling, and testing in accordance with Table 6. Supply the Engineer with a list of certified personnel and copies of their current certificates before beginning production and when personnel changes are made. Provide a mixture design developed and signed by a Level 2 certified specialist. Provide Level 1A certified specialists at the plant during production operations. Provide Level 1B certified specialists to conduct placement tests.

**Table 6**  
**Test Methods, Test Responsibility, and Minimum Certification Levels**

Test Description	Test Method	Contractor	Engineer	Level <sup>1</sup>
<b>1. Aggregate and Recycled Material Testing</b>				
Sampling	Tex-221-F	✓	✓	1A
Dry sieve	Tex-200-F, Part I	✓	✓	1A
Washed sieve	Tex-200-F, Part II	✓	✓	1A
Deleterious material	Tex-217-F, Parts I & III	✓	✓	1A
Decantation	Tex-217-F, Part II	✓	✓	1A
Los Angeles abrasion	Tex-410-A		✓	TxDOT
Magnesium sulfate soundness	Tex-411-A		✓	TxDOT
Micro-Deval abrasion	Tex-461-A		✓	2
Crushed face count	Tex-460-A	✓	✓	2
Flat and elongated particles	Tex-280-F	✓	✓	2
Linear shrinkage	Tex-107-E	✓	✓	2
Sand equivalent	Tex-203-F	✓	✓	2
Organic impurities	Tex-408-A	✓	✓	2
<b>2. Asphalt Binder &amp; Tack Coat Sampling</b>				
Asphalt binder sampling	Tex-500-C, Part II	✓	✓	1A/1B
Tack coat sampling	Tex-500-C, Part III	✓	✓	1A/1B
<b>3. Mix Design &amp; Verification</b>				
Design and JMF changes	Tex-204-F	✓	✓	2
Mixing	Tex-205-F	✓	✓	2
Molding (TGC)	Tex-206-F	✓	✓	1A
Molding (SGC)	Tex-241-F	✓	✓	1A
Laboratory-molded density	Tex-207-F	✓	✓	1A
VMA <sup>2</sup> (calculation only)	Tex-204-F	✓	✓	2
Rice gravity	Tex-227-F	✓	✓	1A
Ignition oven correction factors <sup>3</sup>	Tex-236-F	✓	✓	2
Indirect tensile strength	Tex-226-F	✓	✓	2
Hamburg Wheel test	Tex-242-F	✓	✓	2
Boil test	Tex-530-C	✓	✓	1A
<b>4. Production Testing</b>				
Selecting production random numbers	Tex-225-F, Part I		✓	1A
Mixture sampling	Tex-222-F	✓	✓	1A
Molding (TGC)	Tex-206-F	✓	✓	1A
Molding (SGC)	Tex-241-F	✓	✓	1A
Laboratory-molded density	Tex-207-F	✓	✓	1A
VMA <sup>2</sup> (calculation only)	Tex-204-F	✓	✓	1A
Rice gravity	Tex-227-F	✓	✓	1A
Gradation & asphalt binder content <sup>3</sup>	Tex-236-F	✓	✓	1A
Control charts	Tex-233-F	✓	✓	1A
Moisture content	Tex-212-F	✓	✓	1A
Hamburg Wheel test	Tex-242-F	✓	✓	2
Micro-Deval abrasion	Tex-461-A		✓	2
Boil test	Tex-530-C	✓	✓	1A
Abson recovery	Tex-211-F		✓	TxDOT
Overlay test	Tex-248-F		✓	TxDOT
Cantabro loss	Tex-245-F		✓	2
<b>5. Placement Testing</b>				
Selecting placement random numbers	Tex-225-F, Part II		✓	1A/1B
Trimming roadway cores	Tex-207-F	✓	✓	1A/1B
In-place air voids	Tex-207-F	✓	✓	1A/1B
Establish rolling pattern	Tex-207-F	✓		1B
Control charts	Tex-233-F	✓	✓	1A
Ride quality measurement	Tex-1001-S	✓	✓	Note <sup>4</sup>
Segregation (density profile)	Tex-207-F, Part V	✓	✓	1B
Longitudinal joint density	Tex-207-F, Part VII	✓	✓	1B
Thermal profile	Tex-244-F	✓	✓	1B

- Level 1A, 1B, and 2 are certification levels provided by the Hot Mix Asphalt Center certification program.
- Void in mineral aggregates.
- Refer to Section 341.4.9.2.3, "Production Testing," for exceptions to using an ignition oven.
- Profiler and operator are required to be certified at the Texas A&M Transportation Institute facility when Surface Test Type B is specified.

- 4.2. **Reporting and Responsibilities.** Use Department-provided Excel templates to record and calculate all test data, including mixture design, production and placement QC/QA, control charts, thermal profiles, segregation density profiles, and longitudinal joint density. Obtain the latest version of the Excel templates at <http://www.txdot.gov/inside-txdot/forms-publications/consultants-contractors/forms/site-manager.html> or from the Engineer. The Engineer and the Contractor will provide any available test results to the other party when requested. The maximum allowable time for the Contractor and Engineer to exchange test data is as given in Table 7 unless otherwise approved. The Engineer and the Contractor will immediately report to the other party any test result that requires suspension of production or placement, a payment penalty, or that fails to meet the specification requirements. Record and submit all test results and pertinent information on Department-provided Excel templates to the Engineer electronically by means of a portable USB flash drive, compact disc, or via email.

Subsequent sublots placed after test results are available to the Contractor, which require suspension of operations, may be considered unauthorized work. Unauthorized work will be accepted or rejected at the discretion of the Engineer in accordance with Article 5.3., "Conformity with Plans, Specifications, and Special Provisions."

**Table 7**  
**Reporting Schedule**

Description	Reported By	Reported To	To Be Reported Within
<b>Production Quality Control</b>			
Gradation <sup>1</sup>	Contractor	Engineer	1 working day of completion of the sublot
Asphalt binder content <sup>1</sup>			
Laboratory-molded density <sup>2</sup>			
Moisture content <sup>3</sup>			
Boil test <sup>3</sup>			
<b>Production Quality Assurance</b>			
Gradation <sup>3</sup>	Engineer	Contractor	1 working day of completion of the sublot
Asphalt binder content <sup>3</sup>			
Laboratory-molded density <sup>1</sup>			
Hamburg Wheel test <sup>2</sup>			
Boil test <sup>3</sup>			
Binder tests <sup>2</sup>			
<b>Placement Quality Control</b>			
In-place air voids <sup>2</sup>	Contractor	Engineer	1 working day of completion of the lot
Segregation <sup>1</sup>			
Longitudinal joint density <sup>1</sup>			
Thermal profile <sup>1</sup>			
<b>Placement Quality Assurance</b>			
In-place air voids <sup>1</sup>	Engineer	Contractor	1 working day of receipt of the trimmed cores for in-place air voids <sup>4</sup>
Segregation <sup>2</sup>			
Longitudinal joint density <sup>2</sup>			
Thermal profile <sup>2</sup>			
Aging ratio <sup>2</sup>			
Pay adjustment summary	Engineer	Contractor	2 working days of performing all required tests and receiving Contractor test data

1. These tests are required on every sublot.
2. Optional test. To be reported as soon as results become available.
3. To be performed at the frequency specified on the plans.
4. 2 days are allowed if cores cannot be dried to constant weight within 1 day.

The Engineer will use the Department-provided Excel template to calculate all pay adjustment factors for the lot. Sublot samples may be discarded after the Engineer and Contractor sign off on the pay adjustment summary documentation for the lot.

Use the procedures described in Tex-233-F to plot the results of all quality control (QC) and quality assurance (QA) testing. Update the control charts as soon as test results for each sublot become available. Make the control charts readily accessible at the field laboratory. The Engineer may suspend production for failure to update control charts.

- 4.3. **Quality Control Plan (QCP).** Develop and follow the QCP in detail. Obtain approval for changes to the QCP made during the project. The Engineer may suspend operations if the Contractor fails to comply with the QCP.

Submit a written QCP before the mandatory pre-paving meeting. Receive approval of the QCP before beginning production. Include the following items in the QCP:

- 4.3.1. **Project Personnel.** For project personnel, include:
- a list of individuals responsible for QC with authority to take corrective action;
  - current contact information for each individual listed; and
  - current copies of certification documents for individuals performing specified QC functions.
- 4.3.2. **Material Delivery and Storage.** For material delivery and storage, include:
- the sequence of material processing, delivery, and minimum quantities to assure continuous plant operations;
  - aggregate stockpiling procedures to avoid contamination and segregation;
  - frequency, type, and timing of aggregate stockpile testing to assure conformance of material requirements before mixture production; and
  - procedure for monitoring the quality and variability of asphalt binder.
- 4.3.3. **Production.** For production, include:
- loader operation procedures to avoid contamination in cold bins;
  - procedures for calibrating and controlling cold feeds;
  - procedures to eliminate debris or oversized material;
  - procedures for adding and verifying rates of each applicable mixture component (e.g., aggregate, asphalt binder, RAP, RAS, lime, liquid antistriper, WMA);
  - procedures for reporting job control test results; and
  - procedures to avoid segregation and drain-down in the silo.
- 4.3.4. **Loading and Transporting.** For loading and transporting, include:
- type and application method for release agents; and
  - truck loading procedures to avoid segregation.
- 4.3.5. **Placement and Compaction.** For placement and compaction, include:
- proposed agenda for mandatory pre-paving meeting, including date and location;
  - proposed paving plan (e.g., paving widths, joint offsets, and lift thicknesses);
  - type and application method for release agents in the paver and on rollers, shovels, lutes, and other utensils;
  - procedures for the transfer of mixture into the paver, while avoiding segregation and preventing material spillage;
  - process to balance production, delivery, paving, and compaction to achieve continuous placement operations and good ride quality;
  - paver operations (e.g., operation of wings, height of mixture in auger chamber) to avoid physical and thermal segregation and other surface irregularities; and
  - procedures to construct quality longitudinal and transverse joints.

4.4. **Mixture Design.**

- 4.4.1. **Design Requirements.** The Contractor may design the mixture using a Texas Gyrotory Compactor (TGC) or a Superpave Gyrotory Compactor (SGC) unless otherwise shown on the plans. Use the typical weight design example given in Tex-204-F, Part I, when using a TGC. Use the Superpave mixture design procedure given

in Tex-204-F, Part IV, when using a SGC. Design the mixture to meet the requirements listed in Tables 1, 2, 3, 4, 5, 8, 9, and 10.

- 4.4.1.1. **Target Laboratory-Molded Density When The TGC Is Used.** Design the mixture at a 96.5% target laboratory-molded density. Increase the target laboratory-molded density to 97.0% or 97.5% at the Contractor's discretion or when shown on the plans or specification.
- 4.4.1.2. **Design Number of Gyration (Ndesign) When The SGC Is Used.** Design the mixture at 50 gyrations (Ndesign). Use a target laboratory-molded density of 96.0% to design the mixture; however, adjustments can be made to the Ndesign value as noted in Table 9. The Ndesign level may be reduced to no less than 35 gyrations at the Contractor's discretion.

Use an approved laboratory from the Department's MPL to perform the Hamburg Wheel test, and provide results with the mixture design, or provide the laboratory mixture and request that the Department perform the Hamburg Wheel test. The Engineer will be allowed 10 working days to provide the Contractor with Hamburg Wheel test results on the laboratory mixture design.

The Engineer will provide the mixture design when shown on the plans. The Contractor may submit a new mixture design at any time during the project. The Engineer will verify and approve all mixture designs (JMF1) before the Contractor can begin production.

Provide the Engineer with a mixture design report using the Department-provided Excel template. Include the following items in the report:

- the combined aggregate gradation, source, specific gravity, and percent of each material used;
- asphalt binder content and aggregate gradation of RAP and RAS stockpiles;
- the target laboratory-molded density (or Ndesign level when using the SGC);
- results of all applicable tests;
- the mixing and molding temperatures;
- the signature of the Level 2 person or persons that performed the design;
- the date the mixture design was performed; and
- a unique identification number for the mixture design.

**Table 8**  
**Master Gradation Limits (% Passing by Weight or Volume) and VMA Requirements**

Sieve Size	A Coarse Base	B Fine Base	C Coarse Surface	D Fine Surface	F Fine Mixture
2"	100.0 <sup>1</sup>	—	—	—	—
1-1/2"	98.0–100.0	100.0 <sup>1</sup>	—	—	—
1"	78.0–94.0	98.0–100.0	100.0 <sup>1</sup>	—	—
3/4"	64.0–85.0	84.0–98.0	95.0–100.0	100.0 <sup>1</sup>	—
1/2"	50.0–70.0	—	—	98.0–100.0	100.0 <sup>1</sup>
3/8"	—	60.0–80.0	70.0–85.0	85.0–100.0	98.0–100.0
#4	30.0–50.0	40.0–60.0	43.0–63.0	50.0–70.0	70.0–90.0
#8	22.0–36.0	29.0–43.0	32.0–44.0	35.0–46.0	38.0–48.0
#30	8.0–23.0	13.0–28.0	14.0–28.0	15.0–29.0	12.0–27.0
#50	3.0–19.0	6.0–20.0	7.0–21.0	7.0–20.0	6.0–19.0
#200	2.0–7.0	2.0–7.0	2.0–7.0	2.0–7.0	2.0–7.0
<b>Design VMA, % Minimum</b>					
—	12.0	13.0	14.0	15.0	16.0
<b>Production (Plant-Produced) VMA, % Minimum</b>					
—	11.5	12.5	13.5	14.5	15.5

1. Defined as maximum sieve size. No tolerance allowed.

**Table 9  
Laboratory Mixture Design Properties**

Mixture Property	Test Method	Requirement
Target laboratory-molded density, % (TGC)	Tex-207-F	96.5 <sup>1</sup>
Design gyrations (N <sub>design</sub> for SGC)	Tex-241-F	50 <sup>2</sup>
Indirect tensile strength (dry), psi	Tex-226-F	85–200 <sup>3</sup>
Boil test <sup>4</sup>	Tex-530-C	–

- Increase to 97.0% or 97.5% at the Contractor's discretion or when shown on the plans or specification.
- Adjust within a range of 35–100 gyrations when shown on the plans or specification or when mutually agreed between the Engineer and Contractor.
- The Engineer may allow the IDT strength to exceed 200 psi if the corresponding Hamburg Wheel rut depth is greater than 3.0 mm and less than 12.5 mm.
- Used to establish baseline for comparison to production results. May be waived when approved.

**Table 10  
Hamburg Wheel Test Requirements**

High-Temperature Binder Grade	Test Method	Minimum # of Passes <sup>1</sup>
		@ 12.5 mm <sup>2</sup> Rut Depth, Tested @ 50°C
PG 64 or lower	Tex-242-F	10,000
PG 70		15,000
PG 76 or higher		20,000

- May be decreased or waived when shown on the plans.
- When the rut depth at the required minimum number of passes is less than 3 mm, the Engineer may require the Contractor to increase the target laboratory-molded density (TGC) by 0.5% to no more than 97.5% or lower the N<sub>design</sub> level (SGC) to no less than 35 gyrations.

4.4.2. **Job-Mix Formula Approval.** The job-mix formula (JMF) is the combined aggregate gradation, target laboratory-molded density (or N<sub>design</sub> level), and target asphalt percentage used to establish target values for hot-mix production. JMF1 is the original laboratory mixture design used to produce the trial batch. When WMA is used, JMF1 may be designed and submitted to the Engineer without including the WMA additive. When WMA is used, document the additive or process used and recommended rate on the JMF1 submittal. The Engineer and the Contractor will verify JMF1 based on plant-produced mixture from the trial batch unless otherwise approved. The Engineer may accept an existing mixture design previously used on a Department project and may waive the trial batch to verify JMF1. The Department may require the Contractor to reimburse the Department for verification tests if more than 2 trial batches per design are required.

4.4.2.1. **Contractor's Responsibilities.**

4.4.2.1.1. **Providing Gyrotory Compactor.** Use a TGC calibrated in accordance with Tex-914-K when electing or required to design the mixture in accordance with Tex-204-F, Part I, for molding production samples. Furnish an SGC calibrated in accordance with Tex-241-F when electing or required to design the mixture in accordance with Tex-204-F, Part IV, for molding production samples. Locate the SGC, if used, at the Engineer's field laboratory and make the SGC available to the Engineer for use in molding production samples.

4.4.2.1.2. **Gyrotory Compactor Correlation Factors.** Use Tex-206-F, Part II, to perform a gyrotory compactor correlation when the Engineer uses a different gyrotory compactor. Apply the correlation factor to all subsequent production test results.

4.4.2.1.3. **Submitting JMF1.** Furnish a mix design report (JMF1) with representative samples of all component materials and request approval to produce the trial batch. Provide approximately 10,000 g of the design mixture if opting to have the Department perform the Hamburg Wheel test on the laboratory mixture, and request that the Department perform the test.

4.4.2.1.4. **Supplying Aggregates.** Provide approximately 40 lb. of each aggregate stockpile unless otherwise directed.

- 4.4.2.1.5. **Supplying Asphalt.** Provide at least 1 gal. of the asphalt material and sufficient quantities of any additives proposed for use.
- 4.4.2.1.6. **Ignition Oven Correction Factors.** Determine the aggregate and asphalt correction factors from the ignition oven in accordance with Tex-236-F. Provide the Engineer with split samples of the mixtures before the trial batch production, including all additives (except water), and blank samples used to determine the correction factors for the ignition oven used for QA testing during production. Correction factors established from a previously approved mixture design may be used for the current mixture design if the mixture design and ignition oven are the same as previously used, unless otherwise directed.
- 4.4.2.1.7. **Boil Test.** Perform the test and retain the tested sample from Tex-530-C until completion of the project or as directed. Use this sample for comparison purposes during production. The Engineer may waive the requirement for the boil test.
- 4.4.2.1.8. **Trial Batch Production.** Provide a plant-produced trial batch upon receiving conditional approval of JMF1 and authorization to produce a trial batch, including the WMA additive or process if applicable, for verification testing of JMF1 and development of JMF2. Produce a trial batch mixture that meets the requirements in Table 4, Table 5, and Table 11. The Engineer may accept test results from recent production of the same mixture instead of a new trial batch.
- 4.4.2.1.9. **Trial Batch Production Equipment.** Use only equipment and materials proposed for use on the project to produce the trial batch.
- 4.4.2.1.10. **Trial Batch Quantity.** Produce enough quantity of the trial batch to ensure that the mixture meets the specification requirements.
- 4.4.2.1.11. **Number of Trial Batches.** Produce trial batches as necessary to obtain a mixture that meets the specification requirements.
- 4.4.2.1.12. **Trial Batch Sampling.** Obtain a representative sample of the trial batch and split it into 3 equal portions in accordance with Tex-222-F. Label these portions as "Contractor," "Engineer," and "Referee." Deliver samples to the appropriate laboratory as directed.
- 4.4.2.1.13. **Trial Batch Testing.** Test the trial batch to ensure the mixture produced using the proposed JMF1 meets the mixture requirements in Table 11. Ensure the trial batch mixture is also in compliance with the Hamburg Wheel requirement in Table 10. Use a Department-approved laboratory to perform the Hamburg Wheel test on the trial batch mixture or request that the Department perform the Hamburg Wheel test. The Engineer will be allowed 10 working days to provide the Contractor with Hamburg Wheel test results on the trial batch. Provide the Engineer with a copy of the trial batch test results.
- 4.4.2.1.14. **Development of JMF2.** Evaluate the trial batch test results after the Engineer grants full approval of JMF1 based on results from the trial batch, determine the optimum mixture proportions, and submit as JMF2. Adjust the asphalt binder content or gradation to achieve the specified target laboratory-molded density. The asphalt binder content established for JMF2 is not required to be within any tolerance of the optimum asphalt binder content established for JMF1; however, mixture produced using JMF2 must meet the voids in mineral aggregates (VMA) requirements for production shown in Table 8. If the optimum asphalt binder content for JMF2 is more than 0.5% lower than the optimum asphalt binder content for JMF1, the Engineer may perform or require the Contractor to perform Tex-226-F on Lot 1 production to confirm the indirect tensile strength does not exceed 200 psi. Verify that JMF2 meets the mixture requirements in Table 5.
- 4.4.2.1.15. **Mixture Production.** Use JMF2 to produce Lot 1 as described in Section 341.4.9.3.1.1., "Lot 1 Placement," after receiving approval for JMF2 and a passing result from the Department's or a Department-approved laboratory's Hamburg Wheel test on the trial batch. If desired, proceed to Lot 1 production, once JMF2 is approved, at the Contractor's risk without receiving the results from the Department's Hamburg Wheel test on the trial batch.

Notify the Engineer if electing to proceed without Hamburg Wheel test results from the trial batch. Note that the Engineer may require up to the entire subplot of any mixture failing the Hamburg Wheel test to be removed and replaced at the Contractor's expense.

4.4.2.1.16. **Development of JMF3.** Evaluate the test results from Lot 1, determine the optimum mixture proportions, and submit as JMF3 for use in Lot 2.

4.4.2.1.17. **JMF Adjustments.** If JMF adjustments are necessary to achieve the specified requirements, make the adjustments before beginning a new lot. The adjusted JMF must:

- be provided to the Engineer in writing before the start of a new lot;
- be numbered in sequence to the previous JMF;
- meet the mixture requirements in Table 4 and Table 5;
- meet the master gradation limits shown in Table 8; and
- be within the operational tolerances of JMF2 listed in Table 11.

4.4.2.1.18. **Requesting Referee Testing.** Use referee testing, if needed, in accordance with Section 341.4.9.1., "Referee Testing," to resolve testing differences with the Engineer.

**Table 11  
Operational Tolerances**

Description	Test Method	Allowable Difference Between Trial Batch and JMF1 Target	Allowable Difference from Current JMF Target	Allowable Difference between Contractor and Engineer <sup>1</sup>
Individual % retained for #8 sieve and larger	Tex-200-F or Tex-236-F	Must be Within Master Grading Limits in Table 8	±5.0 <sup>2,3</sup>	±5.0
Individual % retained for sieves smaller than #8 and larger than #200			±3.0 <sup>2,3</sup>	±3.0
% passing the #200 sieve			±2.0 <sup>2,3</sup>	±1.6
Asphalt binder content, %	Tex-236-F	±0.5	±0.3 <sup>3</sup>	±0.3
Laboratory-molded density, %	Tex-207-F	±1.0	±1.0	±1.0
In-place air voids, %		N/A	N/A	±1.0
Laboratory-molded bulk specific gravity		N/A	N/A	±0.020
VMA, %, min	Tex-204-F	Note <sup>4</sup>	Note <sup>4</sup>	N/A
Theoretical maximum specific (Rice) gravity	Tex-227-F	N/A	N/A	±0.020

1. Contractor may request referee testing only when values exceed these tolerances.
2. When within these tolerances, mixture production gradations may fall outside the master grading limits; however, the % passing the #200 will be considered out of tolerance when outside the master grading limits.
3. Only applies to mixture produced for Lot 1 and higher.
4. Test and verify that Table 8 requirements are met.

4.4.2.2. **Engineer's Responsibilities.**

4.4.2.2.1. **Gyratory Compactor.** For mixtures designed in accordance with Tex-204-F, Part I, the Engineer will use a Department TGC, calibrated in accordance with Tex-914-K, to mold samples for trial batch and production testing. The Engineer will make the Department TGC and the Department field laboratory available to the Contractor for molding verification samples, if requested by the Contractor.

For mixtures designed in accordance with Tex-204-F, Part IV, the Engineer will use a Department SGC, calibrated in accordance with Tex-241-F, to mold samples for laboratory mixture design verification. For molding trial batch and production specimens, the Engineer will use the Contractor-provided SGC at the field laboratory or provide and use a Department SGC at an alternate location. The Engineer will make the Contractor-provided SGC in the Department field laboratory available to the Contractor for molding verification samples.

4.4.2.2.2. **Conditional Approval of JMF1 and Authorizing Trial Batch.** The Engineer will review and verify conformance of the following information within 2 working days of receipt:

- the Contractor's mix design report (JMF1);
- the Contractor-provided Hamburg Wheel test results;

- all required materials including aggregates, asphalt, additives, and recycled materials; and
- the mixture specifications.

The Engineer will grant the Contractor conditional approval of JMF1 if the information provided on the paper copy of JMF1 indicates that the Contractor's mixture design meets the specifications. When the Contractor does not provide Hamburg Wheel test results with laboratory mixture design, 10 working days are allowed for conditional approval of JMF1. The Engineer will base full approval of JMF1 on the test results on mixture from the trial batch.

Unless waived, the Engineer will determine the Micro-Deval abrasion loss in accordance with Section 341.2.1.1.2., "Micro-Deval Abrasion." If the Engineer's test results are pending after 2 working days, conditional approval of JMF1 will still be granted within 2 working days of receiving JMF1. When the Engineer's test results become available, they will be used for specification compliance.

After conditionally approving JMF1, including either Contractor- or Department-supplied Hamburg Wheel test results, the Contractor is authorized to produce a trial batch.

- 4.4.2.2.3. **Hamburg Wheel Testing of JMF1.** If the Contractor requests the option to have the Department perform the Hamburg Wheel test on the laboratory mixture, the Engineer will mold samples in accordance with Tex-242-F to verify compliance with the Hamburg Wheel test requirement in Table 10.
- 4.4.2.2.4. **Ignition Oven Correction Factors.** The Engineer will use the split samples provided by the Contractor to determine the aggregate and asphalt correction factors for the ignition oven used for QA testing during production in accordance with Tex-236-F.
- 4.4.2.2.5. **Testing the Trial Batch.** Within 1 full working day, the Engineer will sample and test the trial batch to ensure that the mixture meets the requirements in Table 11. If the Contractor requests the option to have the Department perform the Hamburg Wheel test on the trial batch mixture, the Engineer will mold samples in accordance with Tex-242-F to verify compliance with the Hamburg Wheel test requirement in Table 10.
- The Engineer will have the option to perform the following tests on the trial batch:
- Tex-226-F, to verify that the indirect tensile strength meets the requirement shown in Table 9; and
  - Tex-530-C, to retain and use for comparison purposes during production.
- 4.4.2.2.6. **Full Approval of JMF1.** The Engineer will grant full approval of JMF1 and authorize the Contractor to proceed with developing JMF2 if the Engineer's results for the trial batch meet the requirements in Table 11. The Engineer will notify the Contractor that an additional trial batch is required if the trial batch does not meet these requirements.
- 4.4.2.2.7. **Approval of JMF2.** The Engineer will approve JMF2 within one working day if the mixture meets the requirements in Table 5 and the gradation meets the master grading limits shown in Table 8. The asphalt binder content established for JMF2 is not required to be within any tolerance of the optimum asphalt binder content established for JMF1; however, mixture produced using JMF2 must meet the VMA requirements shown in Table 8. If the optimum asphalt binder content for JMF2 is more than 0.5% lower than the optimum asphalt binder content for JMF1, the Engineer may perform or require the Contractor to perform Tex-226-F on Lot 1 production to confirm the indirect tensile strength does not exceed 200 psi.
- 4.4.2.2.8. **Approval of Lot 1 Production.** The Engineer will authorize the Contractor to proceed with Lot 1 production (using JMF2) as soon as a passing result is achieved from the Department's or a Department-approved laboratory's Hamburg Wheel test on the trial batch. The Contractor may proceed at its own risk with Lot 1 production without the results from the Hamburg Wheel test on the trial batch.

If the Department's or Department-approved laboratory's sample from the trial batch fails the Hamburg Wheel test, the Engineer will suspend production until further Hamburg Wheel tests meet the specified values. The Engineer may require up to the entire subplot of any mixture failing the Hamburg Wheel test be removed and replaced at the Contractor's expense.

4.4.2.2.9. **Approval of JMF3 and Subsequent JMF Changes.** JMF3 and subsequent JMF changes are approved if they meet the mixture requirements shown in Table 4, Table 5, and the master grading limits shown in Table 8, and are within the operational tolerances of JMF2 shown in Table 11.

4.5. **Production Operations.** Perform a new trial batch when the plant or plant location is changed. Take corrective action and receive approval to proceed after any production suspension for noncompliance to the specification. Submit a new mix design and perform a new trial batch when the asphalt binder content of:

- any RAP stockpile used in the mix is more than 0.5% higher than the value shown on the mixture design report; or
- RAS stockpile used in the mix is more than 2.0% higher than the value shown on the mixture design report.

4.5.1. **Storage and Heating of Materials.** Do not heat the asphalt binder above the temperatures specified in Item 300, "Asphalts, Oils, and Emulsions," or outside the manufacturer's recommended values. Provide the Engineer with daily records of asphalt binder and hot-mix asphalt discharge temperatures (in legible and discernible increments) in accordance with Item 320, "Equipment for Asphalt Concrete Pavement," unless otherwise directed. Do not store mixture for a period long enough to affect the quality of the mixture, nor in any case longer than 12 hr. unless otherwise approved.

4.5.2. **Mixing and Discharge of Materials.** Notify the Engineer of the target discharge temperature and produce the mixture within 25°F of the target. Monitor the temperature of the material in the truck before shipping to ensure that it does not exceed 350°F (or 275°F for WMA) and is not lower than 215°F. The Department will not pay for or allow placement of any mixture produced above 350°F.

Produce WMA within the target discharge temperature range of 215°F and 275°F when WMA is required. Take corrective action any time the discharge temperature of the WMA exceeds the target discharge range. The Engineer may suspend production operations if the Contractor's corrective action is not successful at controlling the production temperature within the target discharge range. Note that when WMA is produced, it may be necessary to adjust burners to ensure complete combustion such that no burner fuel residue remains in the mixture.

Control the mixing time and temperature so that substantially all moisture is removed from the mixture before discharging from the plant. Determine the moisture content, if requested, by oven-drying in accordance with Tex-212-F, Part II, and verify that the mixture contains no more than 0.2% of moisture by weight. Obtain the sample immediately after discharging the mixture into the truck, and perform the test promptly.

4.6. **Hauling Operations.** Clean all truck beds before use to ensure that mixture is not contaminated. Use a release agent shown on the Department's MPL to coat the inside bed of the truck when necessary.

Use equipment for hauling as defined in Section 341.4.7.3.3., "Hauling Equipment." Use other hauling equipment only when allowed.

4.7. **Placement Operations.** Collect haul tickets from each load of mixture delivered to the project and provide the Department's copy to the Engineer approximately every hour, or as directed. Use a hand-held thermal camera or infrared thermometer, when a thermal imaging system is not used, to measure and record the internal temperature of the mixture as discharged from the truck or Material Transfer Device (MTD) before or as the mix enters the paver and an approximate station number or GPS coordinates on each ticket. Calculate the daily yield and cumulative yield for the specified lift and provide to the Engineer at the end of paving operations for each day unless otherwise directed. The Engineer may suspend production if the Contractor fails to produce and provide haul tickets and yield calculations by the end of paving operations for each day.

Prepare the surface by removing raised pavement markers and objectionable material such as moisture, dirt, sand, leaves, and other loose impediments from the surface before placing mixture. Remove vegetation from pavement edges. Place the mixture to meet the typical section requirements and produce a smooth, finished surface with a uniform appearance and texture. Offset longitudinal joints of successive courses of hot-mix by at least 6 in. Place mixture so that longitudinal joints on the surface course coincide with lane lines, or as

directed. Ensure that all finished surfaces will drain properly. Place the mixture at the rate or thickness shown on the plans. The Engineer will use the guidelines in Table 12 to determine the compacted lift thickness of each layer when multiple lifts are required. The thickness determined is based on the rate of 110 lb./sq. yd. for each inch of pavement unless otherwise shown on the plans.

**Table 12**  
**Compacted Lift Thickness and Required Core Height**

Mixture Type	Compacted Lift Thickness Guidelines		Minimum Untrimmed Core Height (in.) Eligible for Testing
	Minimum (in.)	Maximum (in.)	
A	3.00	6.00	2.00
B	2.50	5.00	1.75
C	2.00	4.00	1.50
D	1.50	3.00	1.25
F	1.25	2.50	1.25

4.7.1. **Weather Conditions.**

4.7.1.1. **When Using a Thermal Imaging System.** The Contractor may pave any time the roadway is dry and the roadway surface temperature is at least 32°F; however, the Engineer may restrict the Contractor from paving surface mixtures if the ambient temperature is likely to drop below 32°F within 12 hr. of paving. Provide output data from the thermal imaging system to demonstrate to the Engineer that no recurring severe thermal segregation exists in accordance with Section 341.4.7.3.1.2., "Thermal Imaging System."

4.7.1.2. **When Not Using a Thermal Imaging System.** Place mixture when the roadway surface temperature is at or above the temperatures listed in Table 13 unless otherwise approved or as shown on the plans. Measure the roadway surface temperature with a hand-held thermal camera or infrared thermometer. The Engineer may allow mixture placement to begin before the roadway surface reaches the required temperature if conditions are such that the roadway surface will reach the required temperature within 2 hr. of beginning placement operations. Place mixtures only when weather conditions and moisture conditions of the roadway surface are suitable as determined by the Engineer. The Engineer may restrict the Contractor from paving if the ambient temperature is likely to drop below 32°F within 12 hr. of paving.

**Table 13**  
**Minimum Pavement Surface Temperatures**

Originally Specified High Temperature Binder Grade	Minimum Pavement Surface Temperatures (°F)	
	Subsurface Layers or Night Paving Operations	Surface Layers Placed in Daylight Operations
PG 64 or lower	45	50
PG 70	55 <sup>1</sup>	60 <sup>1</sup>
PG 76 or higher	60 <sup>1</sup>	60 <sup>1</sup>

1. Contractors may pave at temperatures 10°F lower than these values when utilizing a paving process including WMA or equipment that eliminates thermal segregation. In such cases, use a hand-held thermal camera operated in accordance with Tex-244-F to demonstrate to the satisfaction of the Engineer that the uncompacted mat has no more than 10°F of thermal segregation.

4.7.2. **Tack Coat.** Clean the surface before placing the tack coat. The Engineer will set the rate between 0.04 and 0.10 gal. of residual asphalt per square yard of surface area. Apply a uniform tack coat at the specified rate unless otherwise directed. Apply the tack coat in a uniform manner to avoid streaks and other irregular patterns. Apply a thin, uniform tack coat to all contact surfaces of curbs, structures, and all joints. Allow adequate time for emulsion to break completely before placing any material. Prevent splattering of tack coat when placed adjacent to curb, gutter, and structures. Roll the tack coat with a pneumatic-tire roller to remove streaks and other irregular patterns when directed.

4.7.3. **Lay-Down Operations.**

4.7.3.1. **Thermal Profile.** Use a hand-held thermal camera or a thermal imaging system to obtain a continuous thermal profile in accordance with Tex-244-F. Thermal profiles are not applicable in areas described in Section 341.4.9.3.1.4., "Miscellaneous Areas."

- 4.7.3.1.1. **Thermal Segregation.**
- 4.7.3.1.1.1. **Moderate.** Any areas that have a temperature differential greater than 25°F, but not exceeding 50°F, are deemed as having moderate thermal segregation.
- 4.7.3.1.1.2. **Severe.** Any areas that have a temperature differential greater than 50°F are deemed as having severe thermal segregation.
- 4.7.3.1.2. **Thermal Imaging System.** Review the output results when a thermal imaging system is used, and provide the automated report described in Tex-244-F to the Engineer daily unless otherwise directed. Modify the paving process as necessary to eliminate any recurring (moderate or severe) thermal segregation identified by the thermal imaging system. The Engineer may suspend paving operations if the Contractor cannot successfully modify the paving process to eliminate recurring severe thermal segregation. Density profiles are not required and not applicable when using a thermal imaging system. Provide the Engineer with electronic copies of all daily data files that can be used with the thermal imaging system software to generate temperature profile plots upon completion of the project or as requested by the Engineer.
- 4.7.3.1.3. **Thermal Camera.** Take immediate corrective action to eliminate recurring moderate thermal segregation when a hand-held thermal camera is used. Evaluate areas with moderate thermal segregation by performing density profiles in accordance with Section 341.4.9.3.3.2., "Segregation (Density Profile)." Provide the Engineer with the thermal profile of every subplot within one working day of the completion of each lot. Report the results of each thermal profile in accordance with Section 341.4.2., "Reporting and Responsibilities." The Engineer will use a hand-held thermal camera to obtain a thermal profile at least once per project. No production or placement bonus will be paid for any subplot that contains severe thermal segregation. Suspend operations and take immediate corrective action to eliminate severe thermal segregation unless otherwise directed. Resume operations when the Engineer determines that subsequent production will meet the requirements of this Section. Evaluate areas with severe thermal segregation by performing density profiles in accordance with Section 341.4.9.3.3.2., "Segregation (Density Profile)." Remove and replace the material in any areas that have both severe thermal segregation and a failing result for Segregation (Density Profile) unless otherwise directed. The subplot in question may receive a production and placement bonus if applicable when the defective material is successfully removed and replaced.
- 4.7.3.2. **Windrow Operations.** Operate windrow pickup equipment so that when hot-mix is placed in windrows, substantially all the mixture deposited on the roadbed is picked up and loaded into the paver.
- 4.7.3.3. **Hauling Equipment.** Use belly dumps, live bottom, or end dump trucks to haul and transfer mixture; however, with exception of paving miscellaneous areas, end dump trucks are only allowed when used in conjunction with an MTD with remixing capability or when a thermal imaging system is used unless otherwise allowed.
- 4.7.3.4. **Screed Heaters.** Turn off screed heaters to prevent overheating of the mat if the paver stops for more than 5 min. The Engineer may evaluate the suspect area in accordance with Section 341.4.9.3.3.4., "Recovered Asphalt Dynamic Shear Rheometer (DSR)," if the screed heater remains on for more than 5 min. while the paver is stopped.
- 4.8. **Compaction.** Compact the pavement uniformly to contain between 3.8% and 8.5% in-place air voids. Take immediate corrective action to bring the operation within 3.8% and 8.5% when the in-place air voids exceed the range of these tolerances. The Engineer will allow paving to resume when the proposed corrective action is likely to yield between 3.8% and 8.5% in-place air voids.

Obtain cores in areas placed under Exempt Production, as directed, at locations determined by the Engineer. The Engineer may test these cores and suspend operations or require removal and replacement if the in-place air voids are less than 2.7% or more than 9.9%. Areas defined in Section 341.4.9.3.1.4., "Miscellaneous Areas," are not subject to in-place air void determination.

Furnish the type, size, and number of rollers required for compaction as approved. Use a pneumatic-tire roller to seal the surface unless excessive pickup of fines occurs. Use additional rollers as required to

remove any roller marks. Use only water or an approved release agent on rollers, tamps, and other compaction equipment unless otherwise directed.

Use the control strip method shown in Tex-207-F, Part IV, on the first day of production to establish the rolling pattern that will produce the desired in-place air voids unless otherwise directed.

Use tamps to thoroughly compact the edges of the pavement along curbs, headers, and similar structures and in locations that will not allow thorough compaction with rollers. The Engineer may require rolling with a trench roller on widened areas, in trenches, and in other limited areas.

Complete all compaction operations before the pavement temperature drops below 160°F unless otherwise allowed. The Engineer may allow compaction with a light finish roller operated in static mode for pavement temperatures below 160°F.

Allow the compacted pavement to cool to 160°F or lower before opening to traffic unless otherwise directed. Sprinkle the finished mat with water or limewater, when directed, to expedite opening the roadway to traffic.

4.9. **Acceptance Plan.** Pay adjustments for the material will be in accordance with Section 341.6., "Payment."

Sample and test the hot-mix on a lot and subplot basis. Suspend production until test results or other information indicates to the satisfaction of the Engineer that the next material produced or placed will result in pay factors of at least 1.000, if the production pay factor given in Section 341.6.1., "Production Pay Adjustment Factors," for 2 consecutive lots or the placement pay factor given in Section 341.6.2., "Placement Pay Adjustment Factors," for 2 consecutive lots is below 1.000.

4.9.1. **Referee Testing.** The Construction Division is the referee laboratory. The Contractor may request referee testing if a "remove and replace" condition is determined based on the Engineer's test results, or if the differences between Contractor and Engineer test results exceed the maximum allowable difference shown in Table 11 and the differences cannot be resolved. The Contractor may also request referee testing if the Engineer's test results require suspension of production and the Contractor's test results are within specification limits. Make the request within 5 working days after receiving test results and cores from the Engineer. Referee tests will be performed only on the subplot in question and only for the particular tests in question. Allow 10 working days from the time the referee laboratory receives the samples for test results to be reported. The Department may require the Contractor to reimburse the Department for referee tests if more than 3 referee tests per project are required and the Engineer's test results are closer to the referee test results than the Contractor's test results.

The Construction Division will determine the laboratory-molded density based on the molded specific gravity and the maximum theoretical specific gravity of the referee sample. The in-place air voids will be determined based on the bulk specific gravity of the cores, as determined by the referee laboratory and the Engineer's average maximum theoretical specific gravity for the lot. With the exception of "remove and replace" conditions, referee test results are final and will establish pay adjustment factors for the subplot in question. The Contractor may decline referee testing and accept the Engineer's test results when the placement pay adjustment factor for any subplot results in a "remove and replace" condition. Placement sublots subject to be removed and replaced will be further evaluated in accordance with Section 341.6.2.2., "Placement Sublots Subject to Removal and Replacement."

4.9.2. **Production Acceptance.**

4.9.2.1. **Production Lot.** A production lot consists of 4 equal sublots. The default quantity for Lot 1 is 1,000 tons; however, when requested by the Contractor, the Engineer may increase the quantity for Lot 1 to no more than 4,000 tons. The Engineer will select subsequent lot sizes based on the anticipated daily production such that approximately 3 to 4 sublots are produced each day. The lot size will be between 1,000 tons and 4,000 tons. The Engineer may change the lot size before the Contractor begins any lot.

If the optimum asphalt binder content for JMF2 is more than 0.5% lower than the optimum asphalt binder content for JMF1, the Engineer may perform or require the Contractor to perform Tex-226-F on Lot 1 to

confirm the indirect tensile strength does not exceed 200 psi. Take corrective action to bring the mixture within specification compliance if the indirect tensile strength exceeds 200 psi unless otherwise directed.

4.9.2.1.1. **Incomplete Production Lots.** If a lot is begun but cannot be completed, such as on the last day of production or in other circumstances deemed appropriate, the Engineer may close the lot. Adjust the payment for the incomplete lot in accordance with Section 341.6.1., "Production Pay Adjustment Factors." Close all lots within 5 working days unless otherwise allowed.

4.9.2.2. **Production Sampling.**

4.9.2.2.1. **Mixture Sampling.** Obtain hot-mix samples from trucks at the plant in accordance with Tex-222-F. The sampler will split each sample into 3 equal portions in accordance with Tex-200-F and label these portions as "Contractor," "Engineer," and "Referee." The Engineer will perform or witness the sample splitting and take immediate possession of the samples labeled "Engineer" and "Referee." The Engineer will maintain the custody of the samples labeled "Engineer" and "Referee" until the Department's testing is completed.

4.9.2.2.1.1. **Random Sample.** At the beginning of the project, the Engineer will select random numbers for all production sublots. Determine sample locations in accordance with Tex-225-F. Take one sample for each subplot at the randomly selected location. The Engineer will perform or witness the sampling of production sublots.

4.9.2.2.1.2. **Blind Sample.** For one subplot per lot, the Engineer will obtain and test a "blind" sample instead of the random sample collected by the Contractor. Test either the "blind" or the random sample; however, referee testing (if applicable) will be based on a comparison of results from the "blind" sample. The location of the Engineer's "blind" sample will not be disclosed to the Contractor. The Engineer's "blind" sample may be randomly selected in accordance with Tex-225-F for any subplot or selected at the discretion of the Engineer. The Engineer will use the Contractor's split sample for sublots not sampled by the Engineer.

4.9.2.2.2. **Informational Cantabro and Overlay Testing.** When requested or shown on the plans, select one random subplot from Lot 2 or higher for Cantabro and Overlay testing during the first week of production. Obtain and provide the Engineer with approximately 90 lb. (40 kg) of mixture in sealed containers, boxes, or bags labeled with the Control-Section-Job (CSJ), mixture type, lot, and subplot number. The Engineer will ship the mixture to the Construction Division for Cantabro and Overlay testing. Results from these tests will not be used for specification compliance.

4.9.2.2.3. **Asphalt Binder Sampling.** Obtain a 1-qt. sample of the asphalt binder for each lot of mixture produced. Obtain the sample at approximately the same time the mixture random sample is obtained. Sample from a port located immediately upstream from the mixing drum or pug mill in accordance with Tex-500-C, Part II. Label the can with the corresponding lot and subplot numbers and deliver the sample to the Engineer. The Engineer may also obtain independent samples. If obtaining an independent asphalt binder sample, the Engineer will split a sample of the asphalt binder with the Contractor. The Engineer will test at least one asphalt binder sample per project to verify compliance with Item 300, "Asphalts, Oils, and Emulsions."

4.9.2.3. **Production Testing.** The Contractor and Engineer must perform production tests in accordance with Table 14. The Contractor has the option to verify the Engineer's test results on split samples provided by the Engineer. Determine compliance with operational tolerances listed in Table 11 for all sublots.

Take immediate corrective action if the Engineer's laboratory-molded density on any subplot is less than 95.0% or greater than 98.0% to bring the mixture within these tolerances. The Engineer may suspend operations if the Contractor's corrective actions do not produce acceptable results. The Engineer will allow production to resume when the proposed corrective action is likely to yield acceptable results.

The Engineer may allow alternate methods for determining the asphalt binder content and aggregate gradation if the aggregate mineralogy is such that Tex-236-F does not yield reliable results. Provide evidence that results from Tex-236-F are not reliable before requesting permission to use an alternate method unless otherwise directed. Use the applicable test procedure as directed if an alternate test method is allowed.

**Table 14**  
**Production and Placement Testing Frequency**

Description	Test Method	Minimum Contractor Testing Frequency	Minimum Engineer Testing Frequency
Individual % retained for #8 sieve and larger	Tex-200-F or Tex-236-F	1 per subplot	1 per 12 sublots <sup>1</sup>
Individual % retained for sieves smaller than #8 and larger than #200			
% passing the #200 sieve			
Laboratory-molded density	Tex-207-F	N/A	1 per subplot <sup>1</sup>
Laboratory-molded bulk specific gravity			
In-place air voids			
VMA	Tex-204-F	1 per subplot	1 per project
Segregation (density profile) <sup>2</sup>	Tex-207-F, Part V		
Longitudinal joint density	Tex-207-F, Part VII		
Moisture content	Tex-212-F, Part II	When directed	1 per project
Theoretical maximum specific (Rice) gravity	Tex-227-F	N/A	
Asphalt binder content	Tex-236-F	1 per subplot	
Hamburg Wheel test	Tex-242-F	N/A	
Recycled Asphalt Shingles (RAS) <sup>3</sup>	Tex-217-F, Part III	N/A	
Thermal profile <sup>2</sup>	Tex-244-F	1 per subplot	
Asphalt binder sampling and testing	Tex-500-C	1 per lot (sample only)	
Tack coat sampling and testing	Tex-500-C, Part III	N/A	
Boil test <sup>4</sup>	Tex-530-C	1 per lot	
Cantabro loss <sup>5</sup>	Tex-245-F	1 per project (sample only)	
Overlay test <sup>6</sup>	Tex-248-F		

1. For production defined in Section 341.4.9.4., "Exempt Production," the Engineer will test one per day if 100 tons or more are produced. For Exempt Production, no testing is required when less than 100 tons are produced.
2. Not required when a thermal imaging system is used.
3. Testing performed by the Construction Division or designated laboratory.
4. The Engineer may reduce or waive the sampling and testing requirements based on a satisfactory test history.
5. Testing performed by the Construction Division and for informational purposes only.

4.9.2.4. **Operational Tolerances.** Control the production process within the operational tolerances listed in Table 11. When production is suspended, the Engineer will allow production to resume when test results or other information indicates the next mixture produced will be within the operational tolerances.

4.9.2.4.1. **Gradation.** Suspend operation and take corrective action if any aggregate is retained on the maximum sieve size shown in Table 8. A subplot is defined as out of tolerance if either the Engineer's or the Contractor's test results are out of operational tolerance. Suspend production when test results for gradation exceed the operational tolerances for 3 consecutive sublots on the same sieve or 4 consecutive sublots on any sieve unless otherwise directed. The consecutive sublots may be from more than one lot.

4.9.2.4.2. **Asphalt Binder Content.** A subplot is defined as out of operational tolerance if either the Engineer's or the Contractor's test results exceed the values listed in Table 11. No production or placement bonus will be paid for any subplot that is out of operational tolerance for asphalt binder content. Suspend production and shipment of the mixture if the Engineer's or the Contractor's asphalt binder content deviates from the current JMF by more than 0.5% for any subplot.

4.9.2.4.3. **Void in Mineral Aggregates (VMA).** The Engineer will determine the VMA for every subplot. For sublots when the Engineer does not determine asphalt binder content, the Engineer will use the asphalt binder content results from QC testing performed by the Contractor to determine VMA.

Take immediate corrective action if the VMA value for any subplot is less than the minimum VMA requirement for production listed in Table 8. Suspend production and shipment of the mixture if the Engineer's VMA results on 2 consecutive sublots are below the minimum VMA requirement for production listed in Table 8. No production or placement bonus will be paid for any subplot that does not meet the minimum VMA requirement for production listed in Table 8 based on the Engineer's VMA determination.

Suspend production and shipment of the mixture if the Engineer's VMA result is more than 0.5% below the minimum VMA requirement for production listed in Table 8. In addition to suspending production, the Engineer may require removal and replacement or may allow the subplot to be left in place without payment.

- 4.9.2.4.4. **Hamburg Wheel Test.** The Engineer may perform a Hamburg Wheel test at any time during production, including when the boil test indicates a change in quality from the materials submitted for JMF1. In addition to testing production samples, the Engineer may obtain cores and perform Hamburg Wheel tests on any areas of the roadway where rutting is observed. Suspend production until further Hamburg Wheel tests meet the specified values when the production or core samples fail the Hamburg Wheel test criteria in Table 10. Core samples, if taken, will be obtained from the center of the finished mat or other areas excluding the vehicle wheel paths. The Engineer may require up to the entire subplot of any mixture failing the Hamburg Wheel test to be removed and replaced at the Contractor's expense.

If the Department's or Department approved laboratory's Hamburg Wheel test results in a "remove and replace" condition, the Contractor may request that the Department confirm the results by re-testing the failing material. The Construction Division will perform the Hamburg Wheel tests and determine the final disposition of the material in question based on the Department's test results.

- 4.9.2.5. **Individual Loads of Hot-Mix.** The Engineer can reject individual truckloads of hot-mix. When a load of hot-mix is rejected for reasons other than temperature, contamination, or excessive uncoated particles, the Contractor may request that the rejected load be tested. Make this request within 4 hr. of rejection. The Engineer will sample and test the mixture. If test results are within the operational tolerances shown in Table 11, payment will be made for the load. If test results are not within operational tolerances, no payment will be made for the load.

4.9.3. **Placement Acceptance.**

- 4.9.3.1. **Placement Lot.** A placement lot consists of 4 placement sublots. A placement subplot consists of the area placed during a production subplot.

- 4.9.3.1.1. **Lot 1 Placement.** Placement bonuses for Lot 1 will be in accordance with Section 341.6.2., "Placement Pay Adjustment Factors"; however, no placement penalty will be assessed for any subplot placed in Lot 1 when the in-place air voids are greater than or equal to 2.7% and less than or equal to 9.9%. Remove and replace any subplot with in-place air voids less than 2.7% or greater than 9.9%.

- 4.9.3.1.2. **Incomplete Placement Lots.** An incomplete placement lot consists of the area placed as described in Section 341.4.9.2.1.1., "Incomplete Production Lots," excluding areas defined in Section 341.4.9.3.1.4., "Miscellaneous Areas." Placement sampling is required if the random sample plan for production resulted in a sample being obtained from an incomplete production subplot.

- 4.9.3.1.3. **Shoulders, Ramps, Etc.** Shoulders, ramps, intersections, acceleration lanes, deceleration lanes, and turn lanes are subject to in-place air void determination and pay adjustments unless designated on the plans as not eligible for in-place air void determination. Intersections may be considered miscellaneous areas when determined by the Engineer.

- 4.9.3.1.4. **Miscellaneous Areas.** Miscellaneous areas include areas that typically involve significant handwork or discontinuous paving operations, such as temporary detours, driveways, mailbox turnouts, crossovers, gores, spot level-up areas, and other similar areas. Temporary detours are subject to in-place air void determination when shown on the plans. Miscellaneous areas also include level-ups and thin overlays when the layer thickness specified on the plans is less than the minimum untrimmed core height eligible for testing shown in Table 12. The specified layer thickness is based on the rate of 110 lb./sq. yd. for each inch of pavement unless another rate is shown on the plans. When "level up" is listed as part of the item bid description code, a pay adjustment factor of 1.000 will be assigned for all placement sublots as described in Section 341.6, "Payment." Miscellaneous areas are not eligible for random placement sampling locations. Compact miscellaneous areas in accordance with Section 341.4.8., "Compaction." Miscellaneous areas are not subject to in-place air void determination, thermal profiles testing, segregation (density profiles), or longitudinal joint density evaluations.

## 4.9.3.2.

**Placement Sampling.** The Engineer will select random numbers for all placement sublots at the beginning of the project. The Engineer will provide the Contractor with the placement random numbers immediately after the subplot is completed. Mark the roadway location at the completion of each subplot and record the station number. Determine one random sample location for each placement subplot in accordance with Tex-225-F. Adjust the random sample location by no more than necessary to achieve a 2-ft. clearance if the location is within 2 ft. of a joint or pavement edge.

Shoulders, ramps, intersections, acceleration lanes, deceleration lanes, and turn lanes are always eligible for selection as a random sample location; however, if a random sample location falls on one of these areas and the area is designated on the plans as not subject to in-place air void determination, cores will not be taken for the subplot and a 1.000 pay factor will be assigned to that subplot.

Provide the equipment and means to obtain and trim roadway cores on site. On-site is defined as in close proximity to where the cores are taken. Obtain the cores within one working day of the time the placement subplot is completed unless otherwise approved. Obtain two 6-in. diameter cores side-by-side from within 1 ft. of the random location provided for the placement subplot. For Type D and Type F mixtures, 4-in. diameter cores are allowed. Mark the cores for identification, measure and record the untrimmed core height, and provide the information to the Engineer. The Engineer will witness the coring operation and measurement of the core thickness. Visually inspect each core and verify that the current paving layer is bonded to the underlying layer. Take corrective action if an adequate bond does not exist between the current and underlying layer to ensure that an adequate bond will be achieved during subsequent placement operations.

Trim the cores immediately after obtaining the cores from the roadway in accordance with Tex-207-F if the core heights meet the minimum untrimmed value listed in Table 12. Trim the cores on site in the presence of the Engineer. Use a permanent marker or paint pen to record the lot and subplot numbers on each core as well as the designation as Core A or B. The Engineer may require additional information to be marked on the core and may choose to sign or initial the core. The Engineer will take custody of the cores immediately after they are trimmed and will retain custody of the cores until the Department's testing is completed. Before turning the trimmed cores over to the Engineer, the Contractor may wrap the trimmed cores or secure them in a manner that will reduce the risk of possible damage occurring during transport by the Engineer. After testing, the Engineer will return the cores to the Contractor.

The Engineer may have the cores transported back to the Department's laboratory at the HMA plant via the Contractor's haul truck or other designated vehicle. In such cases where the cores will be out of the Engineer's possession during transport, the Engineer will use Department-provided security bags and the Roadway Core Custody protocol located at <http://www.txdot.gov/business/specifications.htm> to provide a secure means and process that protects the integrity of the cores during transport.

Decide whether to include the pair of cores in the air void determination for that subplot if the core height before trimming is less than the minimum untrimmed value shown in Table 12. Trim the cores as described above before delivering to the Engineer if electing to have the cores included in the air void determination. Deliver untrimmed cores to the Engineer and inform the Engineer of the decision to not have the cores included in air void determination if electing to not have the cores included in air void determination. The placement pay factor for the subplot will be 1.000 if cores will not be included in air void determination.

Instead of the Contractor trimming the cores on site immediately after coring, the Engineer and the Contractor may mutually agree to have the trimming operations performed at an alternate location such as a field laboratory or other similar location. In such cases, the Engineer will take possession of the cores immediately after they are obtained from the roadway and will retain custody of the cores until testing is completed. Either the Department or Contractor representative may perform trimming of the cores. The Engineer will witness all trimming operations in cases where the Contractor representative performs the trimming operation.

Dry the core holes and tack the sides and bottom immediately after obtaining the cores. Fill the hole with the same type of mixture and properly compact the mixture. Repair core holes with other methods when approved.

4.9.3.3. **Placement Testing.** Perform placement tests in accordance with Table 14. After the Engineer returns the cores, the Contractor may test the cores to verify the Engineer's test results for in-place air voids. The allowable differences between the Contractor's and Engineer's test results are listed in Table 11.

4.9.3.3.1. **In-Place Air Voids.** The Engineer will measure in-place air voids in accordance with Tex-207-F and Tex-227-F. Before drying to a constant weight, cores may be pre-dried using a Corelok or similar vacuum device to remove excess moisture. The Engineer will average the values obtained for all sublots in the production lot to determine the theoretical maximum specific gravity. The Engineer will use the average air void content for in-place air voids.

The Engineer will use the vacuum method to seal the core if required by Tex-207-F. The Engineer will use the test results from the unsealed core to determine the placement pay adjustment factor if the sealed core yields a higher specific gravity than the unsealed core. After determining the in-place air void content, the Engineer will return the cores and provide test results to the Contractor.

4.9.3.3.2. **Segregation (Density Profile).** Test for segregation using density profiles in accordance with Tex-207-F, Part V. Density profiles are not required and are not applicable when using a thermal imaging system. Density profiles are not applicable in areas described in Section 341.4.9.3.1.4., "Miscellaneous Areas."

Perform a density profile every time the paver stops for more than 60 sec. on areas that are identified by either the Contractor or the Engineer as having thermal segregation and on any visibly segregated areas unless otherwise approved. Perform a minimum of one profile per subplot if the paver does not stop for more than 60 sec. and there are no visibly segregated areas or areas that are identified as having thermal segregation.

Provide the Engineer with the density profile of every subplot in the lot within one working day of the completion of each lot. Report the results of each density profile in accordance with Section 341.4.2., "Reporting and Responsibilities."

The density profile is considered failing if it exceeds the tolerances in Table 15. No production or placement bonus will be paid for any subplot that contains a failing density profile. When a hand-held thermal camera is used instead of a thermal imaging system, the Engineer will measure the density profile at least once per project. The Engineer's density profile results will be used when available. The Engineer may require the Contractor to remove and replace the area in question if the area fails the density profile and has surface irregularities as defined in Section 341.4.9.3.3.5., "Irregularities." The subplot in question may receive a production and placement bonus if applicable when the defective material is successfully removed and replaced.

Investigate density profile failures and take corrective actions during production and placement to eliminate the segregation. Suspend production if 2 consecutive density profiles fail unless otherwise approved. Resume production after the Engineer approves changes to production or placement methods.

**Table 15**  
**Segregation (Density Profile) Acceptance Criteria**

Mixture Type	Maximum Allowable Density Range (Highest to Lowest)	Maximum Allowable Density Range (Average to Lowest)
Type A & Type B	8.0 pcf	5.0 pcf
Type C, Type D & Type F	6.0 pcf	3.0 pcf

4.9.3.3.3. **Longitudinal Joint Density.**

4.9.3.3.3.1. **Informational Tests.** Perform joint density evaluations while establishing the rolling pattern and verify that the joint density is no more than 3.0 pcf below the density taken at or near the center of the mat. Adjust the rolling pattern, if needed, to achieve the desired joint density. Perform additional joint density evaluations, at least once per subplot, unless otherwise directed.

4.9.3.3.2. **Record Tests.** Perform a joint density evaluation for each subplot at each pavement edge that is or will become a longitudinal joint. Joint density evaluations are not applicable in areas described in Section 341.4.9.3.1.4., "Miscellaneous Areas." Determine the joint density in accordance with Tex-207-F, Part VII. Record the joint density information and submit results on Department forms to the Engineer. The evaluation is considered failing if the joint density is more than 3.0 pcf below the density taken at the core random sample location and the correlated joint density is less than 90.0%. The Engineer will make independent joint density verification at least once per project and may make independent joint density verifications at the random sample locations. The Engineer's joint density test results will be used when available.

Provide the Engineer with the joint density of every subplot in the lot within one working day of the completion of each lot. Report the results of each joint density in accordance with Section 341.4.2., "Reporting and Responsibilities."

Investigate joint density failures and take corrective actions during production and placement to improve the joint density. Suspend production if the evaluations on 2 consecutive sublots fail unless otherwise approved. Resume production after the Engineer approves changes to production or placement methods.

4.9.3.3.4. **Recovered Asphalt Dynamic Shear Rheometer (DSR).** The Engineer may take production samples or cores from suspect areas of the project to determine recovered asphalt properties. Asphalt binders with an aging ratio greater than 3.5 do not meet the requirements for recovered asphalt properties and may be deemed defective when tested and evaluated by the Construction Division. The aging ratio is the DSR value of the extracted binder divided by the DSR value of the original unaged binder. Obtain DSR values in accordance with AASHTO T 315 at the specified high temperature performance grade of the asphalt. The Engineer may require removal and replacement of the defective material at the Contractor's expense. The asphalt binder will be recovered for testing from production samples or cores in accordance with Tex-211-F.

4.9.3.3.5. **Irregularities.** Identify and correct irregularities including segregation, rutting, raveling, flushing, fat spots, mat slippage, irregular color, irregular texture, roller marks, tears, gouges, streaks, uncoated aggregate particles, or broken aggregate particles. The Engineer may also identify irregularities, and in such cases, the Engineer will promptly notify the Contractor. If the Engineer determines that the irregularity will adversely affect pavement performance, the Engineer may require the Contractor to remove and replace (at the Contractor's expense) areas of the pavement that contain irregularities and areas where the mixture does not bond to the existing pavement.

If irregularities are detected, the Engineer may require the Contractor to immediately suspend operations or may allow the Contractor to continue operations for no more than one day while the Contractor is taking appropriate corrective action.

4.9.4. **Exempt Production.** The Engineer may deem the mixture as exempt production for the following conditions:

- anticipated daily production is less than 1,000 tons;
- total production for the project is less than 5,000 tons;
- when mutually agreed between the Engineer and the Contractor; or
- when shown on the plans.

For exempt production, the Contractor is relieved of all production and placement sampling and testing requirements, and the production and placement pay factors are 1.000. All other specification requirements apply, and the Engineer will perform acceptance tests for production and placement listed in Table 14 when 100 tons or more per day are produced.

For exempt production:

- produce, haul, place, and compact the mixture in compliance with the specification and as directed;
- control mixture production to yield a laboratory-molded density that is within  $\pm 1.0\%$  of the target laboratory-molded density as tested by the Engineer;
- compact the mixture in accordance with Section 341.4.8., "Compaction"; and

- when a thermal imaging system is not used, the Engineer may perform segregation (density profiles) and thermal profiles in accordance with the specification.

4.9.5. **Ride Quality.** Measure ride quality in accordance with Item 585, "Ride Quality for Pavement Surfaces," unless otherwise shown on the plans.

---

## 5. MEASUREMENT

Hot mix will be measured by the ton of composite hot-mix, which includes asphalt, aggregate, and additives. Measure the weight on scales in accordance with Item 520, "Weighing and Measuring Equipment."

---

## 6. PAYMENT

The work performed and materials furnished in accordance with this Item and measured as provided under Section 341.5., "Measurement," will be paid for at the unit bid price for "Dense Graded Hot-Mix Asphalt" of the mixture type, SAC, and binder specified. These prices are full compensation for surface preparation, materials including tack coat, placement, equipment, labor, tools, and incidentals.

Pay adjustments for bonuses and penalties will be applied as determined in this Item; however, a pay adjustment factor of 1.000 will be assigned for all placement sublots for "level ups" only when "level up" is listed as part of the item bid description code. A pay adjustment factor of 1.000 will be assigned to all production and placement sublots when "exempt" is listed as part of the item bid description code.

Payment for each subplot, including applicable pay adjustment bonuses, will only be paid for sublots when the Contractor supplies the Engineer with the required documentation for production and placement QC/QA, thermal profiles, segregation density profiles, and longitudinal joint densities in accordance with Section 341.4.2., "Reporting and Responsibilities." When a thermal imaging system is used, documentation is not required for thermal profiles or segregation density profiles on individual sublots; however, the thermal imaging system automated reports described in Tex-244-F are required.

Trial batches will not be paid for unless they are included in pavement work approved by the Department.

Pay adjustment for ride quality will be determined in accordance with Item 585, "Ride Quality for Pavement Surfaces."

6.1. **Production Pay Adjustment Factors.** The production pay adjustment factor is based on the laboratory-molded density using the Engineer's test results. A pay adjustment factor will be determined from Table 16 for each subplot using the deviation from the target laboratory-molded density defined in Table 9. The production pay adjustment factor for completed lots will be the average of the pay adjustment factors for the 4 sublots sampled within that lot.

**Table 16**  
**Production Pay Adjustment Factors for Laboratory-Molded Density<sup>1</sup>**

<b>Absolute Deviation from Target Laboratory-Molded Density</b>	<b>Production Pay Adjustment Factor (Target Laboratory-Molded Density)</b>
0.0	1.050
0.1	1.050
0.2	1.050
0.3	1.044
0.4	1.038
0.5	1.031
0.6	1.025
0.7	1.019
0.8	1.013
0.9	1.006
1.0	1.000
1.1	0.965
1.2	0.930
1.3	0.895
1.4	0.860
1.5	0.825
1.6	0.790
1.7	0.755
1.8	0.720
> 1.8	Remove and replace

1. If the Engineer's laboratory-molded density on any subplot is less than 95.0% or greater than 98.0%, take immediate corrective action to bring the mixture within these tolerances. The Engineer may suspend operations if the Contractor's corrective actions do not produce acceptable results. The Engineer will allow production to resume when the proposed corrective action is likely to yield acceptable results.

- 6.1.1. **Payment for Incomplete Production Lots.** Production pay adjustments for incomplete lots, described under Section 341.4.9.2.1.1., "Incomplete Production Lots," will be calculated using the average production pay factors from all sublots sampled. A production pay factor of 1.000 will be assigned to any lot when the random sampling plan did not result in collection of any samples.
- 6.1.2. **Production Sublots Subject to Removal and Replacement.** If after referee testing, the laboratory-molded density for any subplot results in a "remove and replace" condition as listed in Table 16, the Engineer may require removal and replacement or may allow the subplot to be left in place without payment. The Engineer may also accept the subplot in accordance with Section 5.3.1., "Acceptance of Defective or Unauthorized Work." Replacement material meeting the requirements of this Item will be paid for in accordance with this Section.
- 6.2. **Placement Pay Adjustment Factors.** The placement pay adjustment factor is based on in-place air voids using the Engineer's test results. A pay adjustment factor will be determined from Table 17 for each subplot that requires in-place air void measurement. A placement pay adjustment factor of 1.000 will be assigned to the entire subplot when the random sample location falls in an area designated on the plans as not subject to in-place air void determination. A placement pay adjustment factor of 1.000 will be assigned to quantities placed in areas described in Section 341.4.9.3.1.4., "Miscellaneous Areas." The placement pay adjustment factor for completed lots will be the average of the placement pay adjustment factors for up to 4 sublots within that lot.

**Table 17**  
**Placement Pay Adjustment Factors for In-Place Air Voids**

In-Place Air Voids	Placement Pay Adjustment Factor	In-Place Air Voids	Placement Pay Adjustment Factor
< 2.7	Remove and Replace	6.4	1.042
2.7	0.710	6.5	1.040
2.8	0.740	6.6	1.038
2.9	0.770	6.7	1.036
3.0	0.800	6.8	1.034
3.1	0.830	6.9	1.032
3.2	0.860	7.0	1.030
3.3	0.890	7.1	1.028
3.4	0.920	7.2	1.026
3.5	0.950	7.3	1.024
3.6	0.980	7.4	1.022
3.7	0.998	7.5	1.020
3.8	1.002	7.6	1.018
3.9	1.006	7.7	1.016
4.0	1.010	7.8	1.014
4.1	1.014	7.9	1.012
4.2	1.018	8.0	1.010
4.3	1.022	8.1	1.008
4.4	1.026	8.2	1.006
4.5	1.030	8.3	1.004
4.6	1.034	8.4	1.002
4.7	1.038	8.5	1.000
4.8	1.042	8.6	0.998
4.9	1.046	8.7	0.996
5.0	1.050	8.8	0.994
5.1	1.050	8.9	0.992
5.2	1.050	9.0	0.990
5.3	1.050	9.1	0.960
5.4	1.050	9.2	0.930
5.5	1.050	9.3	0.900
5.6	1.050	9.4	0.870
5.7	1.050	9.5	0.840
5.8	1.050	9.6	0.810
5.9	1.050	9.7	0.780
6.0	1.050	9.8	0.750
6.1	1.048	9.9	0.720
6.2	1.046	> 9.9	Remove and Replace
6.3	1.044		

- 6.2.1. **Payment for Incomplete Placement Lots.** Pay adjustments for incomplete placement lots described under Section 341.4.9.3.1.2., "Incomplete Placement Lots," will be calculated using the average of the placement pay factors from all sublots sampled and sublots where the random location falls in an area designated on the plans as not eligible for in-place air void determination. A placement pay adjustment factor of 1.000 will be assigned to any lot when the random sampling plan did not result in collection of any samples.
- 6.2.2. **Placement Sublots Subject to Removal and Replacement.** If after referee testing, the placement pay adjustment factor for any sublot results in a "remove and replace" condition as listed in Table 17, the Engineer will choose the location of 2 cores to be taken within 3 ft. of the original failing core location. The Contractor will obtain the cores in the presence of the Engineer. The Engineer will take immediate possession of the untrimmed cores and submit the untrimmed cores to the Construction Division, where they will be trimmed if necessary and tested for bulk specific gravity within 10 working days of receipt.

The average bulk specific gravity of the cores will be divided by the Engineer's average maximum theoretical specific gravity for that lot to determine the new pay adjustment factor of the sublot in question. If the new pay adjustment factor is 0.700 or greater, the new pay adjustment factor will apply to that sublot. If the new pay adjustment factor is less than 0.700, no payment will be made for the sublot. Remove and replace the

failing subplot, or the Engineer may allow the subplot to be left in place without payment. The Engineer may also accept the subplot in accordance with Section 5.3.1., "Acceptance of Defective or Unauthorized Work." Replacement material meeting the requirements of this Item will be paid for in accordance with this Section.

- 6.3. **Total Adjusted Pay Calculation.** Total adjusted pay (TAP) will be based on the applicable pay adjustment factors for production and placement for each lot.

$$TAP = (A+B)/2$$

where:

*A* = Bid price × production lot quantity × average pay adjustment factor for the production lot

*B* = Bid price × placement lot quantity × average pay adjustment factor for the placement lot + (bid price × quantity placed in miscellaneous areas × 1.000)

*Production lot quantity* = Quantity actually placed - quantity left in place without payment

*Placement lot quantity* = Quantity actually placed - quantity left in place without payment - quantity placed in miscellaneous areas

## Item 400

### Excavation and Backfill for Structures



#### 1. DESCRIPTION

Excavate for placement and construction of structures and backfill structures. Cut and restore pavement.

#### 2. MATERIALS

Use materials that meet the requirements of the following Items.

- Item 401, "Flowable Backfill"
- Item 421, "Hydraulic Cement Concrete"
- DMS-4600, "Hydraulic Cement"

#### 3. CONSTRUCTION

##### 3.1. Excavation.

- 3.1.1. **General.** Excavate to the lines and grades shown on the plans or as directed. Provide slopes, benching, sheeting, bracing, pumping, and bailing as necessary to maintain the stability and safety of excavations up to 5 ft. deep. Excavation protection for excavations deeper than 5 ft. are governed by Item 402, "Trench Excavation Protection," and Item 403, "Temporary Special Shoring." Use satisfactory excavated material as backfill or as embankment fill in accordance with Item 132, "Embankment." Dispose of material not incorporated into the final project off the right of way in accordance with federal, state, and local regulations.

Keep any topsoil that has been removed separate, and replace it, as nearly as feasible, in its original position when excavating for installation of structures across private property or beyond the limits of the embankment. Restore the area to an acceptable condition.

Excavate drilled shafts in accordance with Item 416, "Drilled Shaft Foundations."

- 3.1.1.1. **Obstructions.** Remove obstructions to the proposed construction, including trees and other vegetation, debris, and structures, over the width of the excavation to a depth of 1 ft. below the bottom of excavation. Remove as required to clear the new structure and plug in an approved manner if abandoned storm drains, sewers, or other drainage systems are encountered. Restore the bottom of the excavation to grade by backfilling after removing obstructions in accordance with this Item. Dispose of surplus materials in accordance with federal, state, and local regulations.

- 3.1.1.2. **Excavation in Streets.** Cut pavement and base to neat lines when structures are installed in streets, highways, or other paved areas. Restore pavement structure after completion of excavation and backfilling.

Maintain and control traffic in accordance with the approved traffic control plan and the TMUTCD.

- 3.1.1.3. **Utilities.** Comply with the requirements of Article 7.19., "Responsibility for Damage Claims." Conduct work with minimum disturbance of existing utilities, and coordinate work in or near utilities with the utility owners. Inform utility owners before work begins, allowing them enough time to identify, locate, reroute, or make other adjustments to utility lines.

Avoid cutting or damaging underground utility lines that are to remain in place. Promptly notify the utility company if damage occurs. Provide temporary flumes across the excavation while open if an active sanitary

sewer line is damaged during excavation, and restore the lines when backfilling has progressed to the original bedding lines of the cut sewer.

- 3.1.1.4. **De-Watering.** Construct or place structures in the presence of water only if approved. Place precast members, pipe, and concrete only on a dry, firm surface. Remove water by bailing, pumping, well-point installation, deep wells, underdrains, or other approved method.

Remove standing water in a manner that does not allow water movement through or alongside concrete being placed if structures are approved for placement in the presence of water. Pump or bail only from a suitable sump separated from the concrete work while placing structural concrete or for a period of at least 36 hr. thereafter. Pump or bail during placement of seal concrete only to the extent necessary to maintain a static head of water within the cofferdam. Pump or bail to de-water inside a sealed cofferdam only after the seal has aged at least 36 hr.

Place a stabilizing material in the bottom of the excavation if the bottom of an excavation cannot be de-watered to the point the subgrade is free of mud or it is difficult to keep reinforcing steel clean. Use flexible base, cement-stabilized base or backfill, lean concrete, or other approved stabilizing material. Provide concrete with at least 275 lb. of cement per cubic yard, if lean concrete is used, and place to a minimum depth of 3 in. Stabilizing material placed for the convenience of the Contractor will be at the Contractor's expense.

- 3.1.2. **Bridge Foundations and Retaining Walls.** Do not disturb material below the bottom of footing grade. Do not backfill to compensate for excavation that has extended below grade. Fill the area with concrete at the time the footing is placed if excavation occurs below the proposed footing grade. Additional concrete placed will be at the Contractor's expense.

Take core samples to determine the character of the supporting materials if requested. Provide an intact sample adequate to judge the character of the founding material. Take these cores when the excavation is close to completion. Cores should be approximately 5 ft. deeper than the proposed founding grade.

Remove loose material if the founding stratum is rock or another hard material, and clean and cut it to a firm surface that is level, stepped, or serrated, as directed. Clean out soft seams, and fill with concrete at the time the footing is placed.

Place the foundation once the Engineer has inspected the excavation and authorized changes have been made to provide a uniform bearing condition if the material at the footing grade of a retaining wall, bridge bent, or pier is a mixture of compressible and incompressible material.

- 3.1.3. **Cofferdams.** The term "cofferdam" designates any temporary or removable structure constructed to hold surrounding earth, water, or both out of the excavation whether the structure is formed of soil, timber, steel, concrete, or a combination of these. Use pumping wells or well points for de-watering cofferdams if required.

Submit details and design calculations for sheet-pile or other types of cofferdams requiring structural members bearing the seal of a licensed professional engineer for review before constructing the cofferdam. The Department reserves the right to reject designs. Design structural systems to comply with the AASHTO *Standard Specifications for Highway Bridges* or AASHTO LRFD *Bridge Design Specifications*. Interior dimensions of cofferdams must provide enough clearance for the construction, inspection, and removal of required forms and, if necessary, enough room to allow pumping outside the forms. Extend sheet-pile cofferdams well below the bottom of the footings, and make concrete seals as well braced and watertight as practicable.

Use Class E concrete for foundation seals unless otherwise specified. Place concrete foundation seals in accordance with Item 420, "Concrete Substructures." Seals placed for the convenience of the Contractor will be at the Contractor's expense.

Make the excavation deep enough to allow for swelling of the material at the base of the excavation during pile-driving operations when the Engineer judges it to be impractical to de-water inside a cofferdam and a

concrete seal is to be placed around piling driven within the cofferdam. Remove swelling material to the bottom of the seal grade after driving the piling. Remove the foundation material to exact footing grades where it is possible to de-water inside the cofferdam without placing a seal after driving piling. Do not backfill a foundation to compensate for excavation that has been extended below grade; fill such areas below grade with concrete at the time the seals or footings are placed.

Remove cofferdams after completing the substructure without disturbing or damaging the structure unless otherwise provided.

- 3.1.4. **Culverts and Storm Drains.** When the design requires special bedding conditions for culverts or storm drains, an excavation diagram will be shown on the plans. Do not exceed these limits of excavation.

Construct pipe structures in an open cut with vertical sides extending to a point 1 ft. above the pipe unless otherwise shown on the plans. When site conditions or the plans do not prohibit sloping the cut, the excavation may be stepped or laid back to a stable slope beginning 1 ft. above the pipe. Maintain the stability of the excavation throughout the construction period.

Construct the embankment for pipe to be installed in fill above natural ground to an elevation at least 1 ft. above the top of the pipe, and then excavate for the pipe.

- 3.1.4.1. **Unstable Material.** Remove the material to a depth of no more than 2 ft. below the grade of the structure when unstable soil is encountered at established footing grade, unless the Engineer authorizes additional depth. Replace soil removed with stable material in uniform layers no greater than 8 in. deep (loose measurement). Each layer must have enough moisture to be compacted by rolling or tamping as required to provide a stable foundation for the structure.

Use special materials such as flexible base, cement-stabilized base, cement-stabilized backfill, or other approved material when it is not feasible to construct a stable foundation as outlined above.

- 3.1.4.2. **Incompressible Material.** Remove the incompressible material to 6 in. below the footing grade, backfill with an approved compressible material, and compact in accordance with Section 400.3.3., "Backfill," if rock, part rock, or other incompressible material is encountered at established footing grade while placing prefabricated elements.

- 3.2. **Shaping and Bedding.** Place at least 2 in. of fine granular material for precast box sections on the base of the excavation before placing the box sections. Use bedding as shown in Figure 1 for pipe installations. Use Class C bedding unless otherwise shown on the plans. The Engineer may require the use of a template to secure reasonably accurate shaping of the foundation material. Undercut the excavation at least 4 in. where cement-stabilized backfill is indicated on the plans and backfill with stabilized material to support the pipe or box at the required grade.

$B_c$  - Outside diameter or horizontal dimension  
 $D$  - Inside diameter of pipe  
 $d$  - Min. bedding material below pipe

D	d
$\leq 27"$	3"
30" to 60"	4"
$\geq 66"$	6"

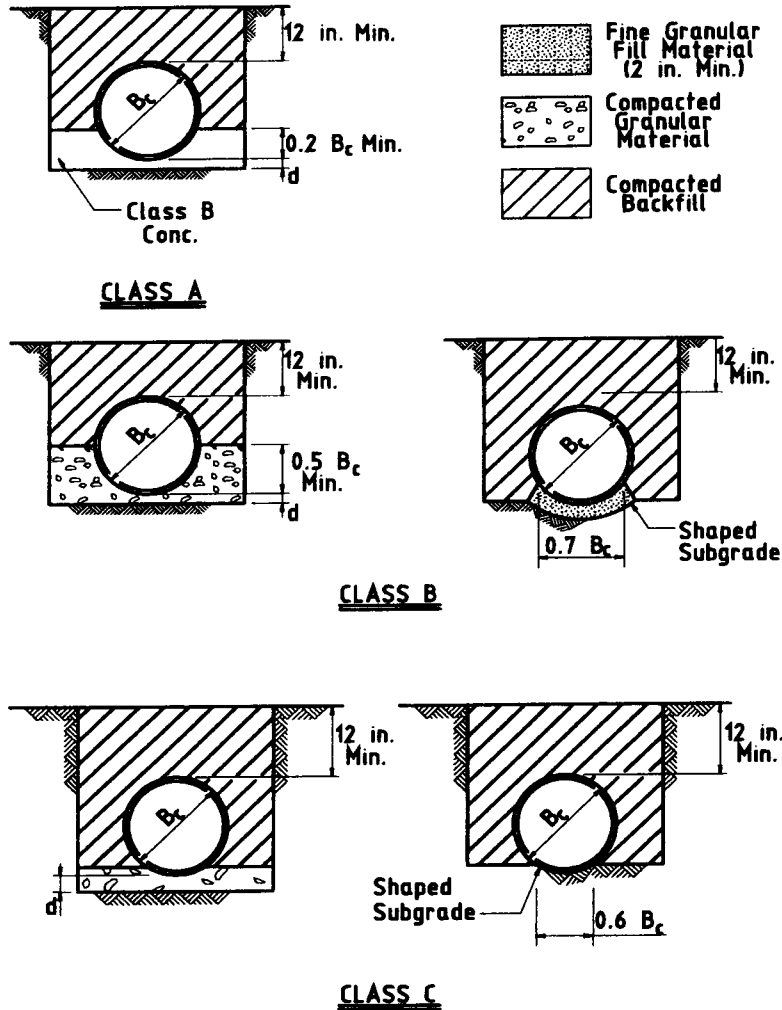

Figure 1  
 Bedding Diagrams

3.3. **Backfill.**

3.3.1. **General.** Backfill the excavation after placement of the permanent structure as soon as practical. Use backfill free from stones large enough to interfere with compaction; large or frozen lumps that will not break down readily under compaction; and wood or other extraneous material. Obtain backfill material from excavation or from other sources.

Place backfill in layers no greater than 10 in. deep (loose measurement) in areas not supporting a completed roadbed, retaining wall, or embankment. Place backfill in uniform layers no greater than 8 in. deep (loose measurement) in areas supporting a portion of a roadbed, retaining wall, or embankment. Compact each layer to meet the density requirements of the roadbed, retaining wall, embankment material, or as shown on the plans.

Bring each layer of backfill material to the moisture content needed to obtain the required density. Use mechanical tamps or rammers to compact the backfill. Rollers may be used to compact backfill if feasible.

Cohesionless materials may be used for backfilling. Use cohesionless materials that conform to the requirements of Table 1.

**Table 1**  
**Cohesionless Material Gradation Limits**

Sieve Size	Percent Retained
3"	0
#10	See Note <sup>1</sup>
#200	90-100

- No. 10 sieve requirements are 0 to 30% retained when used as aggregate for cement-stabilized backfill.

Compact cohesionless materials using vibratory equipment, water-ponding, or a combination of both.

### 3.3.2.

**Bridge Foundations, Retaining Walls, Manholes/Inlets, and Box Culverts.** Place backfill against the structure only after the concrete has reached the design strength required in Item 421, "Hydraulic Cement Concrete."

Backfill retaining walls with material meeting the requirements of Item 423, "Retaining Walls." Backfill around bridge foundations, manholes/inlets and culverts using material with particles no more than 4 in. in greatest dimension and a gradation that permits thorough compaction. Use rock or gravel mixed with soil if the percentage of fines is enough to fill all voids and ensure a uniform and thoroughly compacted mass of proper density.

Use mechanical tamps and rammers to avoid damage to the structure where backfill material is being placed too close to the structure to permit compaction with blading and rolling equipment.

Avoid wedging action of backfill against structures. Step or serrate slopes bounding the excavation to prevent such action. Place backfill uniformly around bridge foundations. Place backfill equally and in uniform layers along both sides of manholes/inlets and culverts.

The Engineer may require backfilling of structures excavated into hard, erosion-resistant material, and subject to erosive forces, with stone or lean concrete.

Box culverts may be opened to traffic as soon as enough backfill and embankment has been placed over the top to protect culverts against damage from heavy construction equipment. Repair damage to culvert caused by construction traffic at no additional expense to the Department.

### 3.3.3.

**Pipe.** Bring backfill material to the proper moisture condition after installing bedding and pipe as required and place it equally along both sides of the pipe in uniform layers no greater than 8 in. deep (loose measurement). Compact each lift mechanically. Thoroughly compact materials placed under the haunches of the pipe to prevent damage or displacement of the pipe. Place backfill in this manner to the top-of-pipe elevation. Place and compact backfill above the top of the pipe in accordance with Section 400.3.3.1., "General."

The Engineer may reject backfill material containing more than 20% by weight of material retained on a 3 in. sieve with large lumps not easily broken down or that cannot be spread in loose layers. Material excavated by a trenching machine will generally meet the requirements of this Section as long as large stones are not present.

Place and compact additional material where pipe extends beyond the toe of slope of the embankment and the depth of cover provided by backfill to the original ground level is less than the minimum required by the specifications for the type of pipe involved until the minimum cover has been provided.

used. When plans provide the option of cast-in-place or precast boxes, measurement will be based on the cast-in-place option.

Where excavation in addition to that allowed for the footings is required for other portions of the structure, measurement for the additional excavation will be limited laterally by vertical planes 1 ft. beyond the face of the member and parallel to it, and vertically to a depth of 1 ft. below the bottom of the member.

- 4.1.1.4. **Excavation near Roadways and Channels.** At structure sites other than culverts and pipe excavations, the measurement of structural excavation will include only material below or outside the limits of the completed road or channel excavation. Roadway and channel excavation will be paid under Item 110, "Excavation." For culverts except side road and private entrance culverts, excavation within the limits of the structure and below or outside the limits of the completed roadway excavation will be measured as structural excavation.
- 4.1.2. **Falsework.** No measurement will be made for excavation necessary for placing forms or falsework that exceeds the limits given in Section 400.4.1.1., "Boundaries of Measurement."
- 4.1.3. **Swelling.** Measurement will not include materials removed below footing grades to compensate for anticipated swelling due to pile-driving, nor will it include material required to be removed due to swelling beyond the specified limits during pile-driving operations.
- 4.1.4. **Cave-Ins.** Measurement will not include additional volume caused by slips, slides, cave-ins, silting, or fill material resulting from the action of the elements or the Contractor's operation.
- 4.1.5. **Undercut.** Where rock or other incompressible or unstable material is undercut to provide a suitable foundation for pipe or box sections, such material below grade directed to be removed will be measured for payment.
- 4.1.6. **Grade Change.** Additional measurement will be made of the volume of excavation involved in the lowering or raising of the elevation of a footing, foundation, or structure unit, when such grade change is authorized.
- 4.2. **Cement-Stabilized Backfill.** Cement-stabilized backfill will be measured by the cubic yard as shown on the plans.
- 4.3. **Cutting and Restoring Pavement.** Cutting and restoring pavement will be measured by the square yard as shown on the plans. Excavation below pavement or base will be measured as structural excavation of the pertinent type.

---

## 5. PAYMENT

- 5.1. **Structural Excavation.** Unless specified as a pay item, structural excavation and backfill performed, and material furnished in accordance with this Item will not be paid for directly but are subsidiary to pertinent Items.

When structural excavation is specified as a pay item, the excavation and backfill work performed, and materials furnished will be paid for at the unit price bid for "Structural Excavation," "Structural Excavation (Box)," "Structural Excavation (Pipe)," and "Structural Excavation (Bridge)." This price includes concrete to compensate for excavation that has extended below grade for bridge foundations and retaining walls, and backfilling and compacting areas that were removed as part of structural excavation.

Cofferdams or other measures necessary for supporting excavations less than 5 ft. deep will not be measured or paid for directly but will be subsidiary to the Contract.

Foundation seal concrete for cofferdams, when required, will be paid for as provided in the pertinent Items. If no direct method of payment is provided in the Contract, the work will be measured and paid for in accordance with Article 9.7., "Payment for Extra Work and Force Account Method." Seal placed for the convenience of the Contractor will not be paid for.

Unless otherwise provided, stone or lean concrete backfill around structures as provided for in Section 400.3.3.2., "Bridge Foundations, Retaining Walls, Manholes/Inlets, and Box Culverts," will be measured and paid for as extra work in accordance with Article 9.7., "Payment for Extra Work and Force Account Method."

When structural excavation is specified as a pay item, a partial payment of 50% of the bid price will be made for structural excavation completed to the satisfaction of the Engineer but not backfilled. The remaining amount will be paid upon completion of backfilling. When the Contractor elects to excavate beyond plan requirements, no measurement will be made of the additional volume.

- 5.2. **Removal and Replacement of Unsuitable or Incompressible Material.** Removal and replacement of material will be paid for if directed. Removal and replacement of material or placement of special material made necessary by the softening of founding material due to the Contractor's sequence of work or operation, will be at the Contractor's expense. Special material used or additional excavation made for the Contractor's convenience will not be paid for.

- 5.2.1. **Structural Excavation as a Pay Item.** Where special materials are not required or specified, payment for the removal and replacement of unstable or incompressible material will be made at a price equal to 200% of the unit price bid per cubic yard for Structural Excavation. When the Contractor elects to remove and replace material deeper than directed, no measurement will be made on that portion below the directed elevation. This price is full compensation for removing the unstable or incompressible material; furnishing, hauling, placing, and compacting suitable replacement material; and equipment, labor, tools, and incidentals.

When the plans specify or when directed, the use of special materials such as flexible base, cement-stabilized base, cement-stabilized backfill, or other special material, payment for excavation below footing grades will be made at the unit price bid for Structural Excavation. Payment for furnishing, hauling, placing, and compacting the flexible base, cement-stabilized base, cement-stabilized backfill, or other special materials will be made at the unit price bid for these items in the Contract, or, if the required material is not a bid item, in accordance with Article 9.7., "Payment for Extra Work and Force Account Method."

- 5.2.2. **Structural Excavation Not a Pay Item.** Where special materials for backfill are not required or specified, payment for the authorized removal and replacement of unstable or incompressible material will be measured and paid for at \$15 per cubic yard of material removed. This price is full compensation for removing the unstable or incompressible material; furnishing, hauling, placing, and compacting suitable replacement material; and equipment, labor, tools, and incidentals.

When the plans specify or when directed, the use of special materials such as flexible base, cement-stabilized base, cement-stabilized backfill, or other special material, excavation below the footing grades will be paid for at \$10 per cubic yard. Payment for furnishing, hauling, placing, and compacting the flexible base, cement-stabilized base, cement-stabilized backfill, or other special materials will be made at the unit price bid for these items, or, if the required material is not a bid item, in accordance with Article 9.7., "Payment for Extra Work and Force Account Method."

- 5.3. **Lowering of a Structure Foundation.** If the Engineer requires a structure foundation to be lowered to an elevation below the grade shown on the plans, overexcavation will be paid in accordance with Table 2.

**Table 2**  
**Payment for Required Overexcavation**

Variance of Revised Footing Grade from Plan Grade	Payment Terms	Variance of Revised Footing Grade from Plan Grade
	"Structural Excavation" is a Bid Item	"Structural Excavation" is not a Bid Item
Up to and including 5 ft.	Unit price equal to 115% of unit price bid for "Structural Excavation"	\$10 per cubic yard
Over 5 ft. up to 10 ft.	Unit price equal to 125% of unit price bid for "Structural Excavation"	\$12 per cubic yard
Over 10 ft.	In accordance with Article 9.7., "Payment for Extra Work and Force Account Method."	

- 5.4. **Cement-Stabilized Backfill.** Cement-stabilized backfill will be paid for at the unit price bid for "Cement-Stabilized Backfill."
- 5.5. **Cutting and Restoring Pavement.** Cutting and restoring pavement will be paid for at the unit price bid for "Cutting and Restoring Pavement" of the type specified.

Work done to repair damage to base or pavement incurred outside the limits shown on the plans, or the limits authorized, will not be measured for payment.

The unit prices bid are full compensation for excavation including removing obstructions and plugging drainage systems; bedding and backfilling including placing, sprinkling and compaction of material; soundings; cleaning and filling seams; constructing and removing cofferdams; de-watering, sheeting, or bracing excavations up to and including 5 ft. deep; pumps; drills; explosives; disposition of surplus material; cutting pavement and base to neat lines; and materials, hauling, equipment, labor, tools, and incidentals.

Flowable backfill will be paid for as provided in Item 401, "Flowable Backfill." Protection methods for open excavations deeper than 5 ft. will be measured and paid for as required under Item 402, "Trench Excavation Protection," or Item 403, "Temporary Special Shoring."

---

**Item 402****Trench Excavation Protection**

---

**1. DESCRIPTION**

Furnish and place excavation protection for trenches 5 ft. or greater in depth.

---

**2. CONSTRUCTION**

Provide vertical or sloped cuts, benches, shields, support systems, or other systems providing the necessary protection in accordance with OSHA Standards and Interpretations, 29 CFR 1926, Subpart P, "Excavations."

---

**3. MEASUREMENT**

This Item will be measured by the foot along the long axis of the trench where the depth of trench exceeds 5 ft. This measurement includes all required trench protection, including trench ends.

---

**4. PAYMENT**

The work performed and materials furnished in accordance with this Item and measured as provided under "Measurement" will be paid for at the unit price bid for "Trench Excavation Protection." This price is full compensation for excavation and backfill required for excavation protection; furnishing, placing, and removing shoring, sheeting, or bracing; de-watering or diversion of water; jacking and jack removal; and equipment, labor, materials, tools, and incidentals.

# Item 464

## Reinforced Concrete Pipe



### 1. DESCRIPTION

Furnish and install reinforced concrete pipe, materials for precast concrete pipe culverts, or precast concrete storm drain mains, laterals, stubs, and inlet leads.

### 2. MATERIALS

- 2.1. **Fabrication.** Fabrication plants must be approved by the Construction Division in accordance with DMS-7310, "Reinforced Concrete Pipe and Machine-Made Precast Concrete Box Culvert Fabrication and Plant Qualification," before furnishing precast reinforced concrete pipe for Department projects. The Department's MPL has a list of approved reinforced concrete pipe plants.

Furnish material and fabricate reinforced concrete pipe in accordance with DMS-7310, "Reinforced Concrete Pipe and Machine-Made Precast Concrete Box Culvert Fabrication and Plant Qualification."

- 2.2. **Design.**

- 2.2.1. **General.** The class and D-load equivalents are shown in Table 1. Furnish arch pipe in accordance with ASTM C506 and the dimensions shown in Table 2. Furnish horizontal elliptical pipe in accordance with ASTM C507 and the dimensions shown in Table 3. For arch pipe and horizontal elliptical pipe the minimum height of cover required is 1 ft.

**Table 1**  
**Circular Pipe**  
**ASTM C76 & ASTM C655**

Class	D-Load
I	800
II	1,000
III	1,350
IV	2,000
V	3,000

**Table 2**  
**Arch Pipe**

Design Size	Equivalent Diameter (in.)	Rise (in.)	Span (in.)
1	18	13-1/2	22
2	21	15-1/2	26
3	24	18	28-1/2
4	30	22-1/2	36-1/4
5	36	26-5/8	43-3/4
6	42	31-5/16	51-1/8
7	48	36	58-1/2
8	54	40	65
9	60	45	73
10	72	54	88

**Table 3**  
**Horizontal Elliptical Pipe**

Design Size	Equivalent Diameter (in.)	Rise (in.)	Span (in.)
1	18	14	23
2	24	19	30
3	27	22	34
4	30	24	38
5	33	27	42
6	36	29	45
7	39	32	49
8	42	34	53
9	48	38	60
10	54	43	68

- 2.2.2. **Jacking, Boring, or Tunneling.** Design pipe for jacking, boring, or tunneling considering the specific installation conditions such as the soil conditions, installation methods, anticipated deflection angles, and jacking stresses. Provide design notes and drawings signed and sealed by a Texas licensed professional engineer when requested.
- 2.3. **Marking.** Furnish each section of reinforced concrete pipe marked with the following information specified in DMS-7310, "Reinforced Concrete Pipe and Machine-Made Precast Concrete Box Culvert Fabrication and Plant Qualification."
- class or D-load of pipe,
  - ASTM designation,
  - date of manufacture,
  - pipe size,
  - name or trademark of fabricator and plant location,
  - designated fabricator's approval stamp,
  - pipe to be used for jacking and boring (when applicable), and
  - designation "SR" for pipe meeting sulfate-resistant concrete plan requirements (when applicable).
- Clearly mark 1 end of each section during the process of manufacture or immediately thereafter for pipe with elliptical reinforcement. Mark the pipe on the inside and outside of opposite walls to show the location of the top or bottom of the pipe as it should be installed unless the external shape of the pipe is such that the correct position of the top and bottom is obvious. Mark the pipe section by indenting or painting with waterproof paint.
- 2.4. **Inspection.** Provide access for inspection of the finished pipe at the project site before and during installation.
- 2.5. **Causes for Rejection.** Individual section of pipe may be rejected for any of the conditions stated in the Annex of DMS-7310, "Reinforced Concrete Pipe and Machine-Made Precast Concrete Box Culvert Fabrication and Plant Qualification."
- 2.6. **Repairs.** Make repairs if necessary as stated in the Annex of DMS-7310, "Reinforced Concrete Pipe and Machine-Made Precast Concrete Box Culvert Fabrication and Plant Qualification."
- 2.7. **Jointing Materials.** Use any of the following materials for the making of joints unless otherwise shown on the plans. Furnish a manufacturer's certificate of compliance for all jointing materials except mortar.
- 2.7.1. **Mortar.** Provide mortar for joints that meets the requirements of Section 464.3.3., "Jointing."
- 2.7.2. **Cold-Applied, Plastic Asphalt Sewer Joint Compound.** Provide a material that consists of natural or processed asphalt base, suitable volatile solvents, and inert filler. Ensure the consistency is such that the ends of the pipe can be coated with a layer of the compound up to 1/2 in. thick by means of a trowel. Provide

a joint compound that cures to a firm, stiff plastic condition after application. Provide a material of a uniform mixture. Stir any small separation found in the container into a uniform mix before using.

Provide a material that meets the requirements of Table 4 when tested in accordance with Tex-526-C.

**Table 4**  
**Cold-Applied, Plastic Asphalt Sewer Joint Compound Material Requirements**

Composition	Analysis
Asphalt base, 100%-% volatiles-% ash, % by weight	28-45
Volatiles, 212°F evaporation, 24 hr., % by weight	10-26
Mineral matter, determined as ash, % by weight	30-55
Consistency, cone penetration, 150 g, 5 sec., 77°F	150-275

- 2.7.3. **Rubber Gaskets.** Provide gaskets that conform to ASTM C1619 Class A or C. Meet the requirements of ASTM C443 for design of the pipe joints and permissible variations in dimensions.
- 2.7.4. **Pre-Formed Flexible Joint Sealants.** Pre-formed flexible joint sealants may be used for sealing joints of tongue-and-groove concrete pipe. Provide flexible joint sealants that meet the requirements of ASTM C990. Use flexible joint sealants that do not depend on oxidizing, evaporating, or chemical action for its adhesive or cohesive strength. Supply in extruded rope form of suitable cross-section. Provide a size of the pre-formed flexible joint sealant in accordance with the manufacturer's recommendations and large enough to properly seal the joint. Protect flexible joint sealants with a suitable wrapper able to maintain the integrity of the jointing material when the wrapper is removed.

### 3. CONSTRUCTION

- 3.1. **Excavation, Shaping, Bedding, and Backfill.** Excavate, shape, bed, and backfill in accordance with Item 400, "Excavation and Backfill for Structures," except where jacking, boring, or tunneling methods are permitted. Jack, bore, or tunnel the pipe in accordance with Item 476, "Jacking, Boring, or Tunneling Pipe or Box." Immediate backfilling is permitted if joints consist of materials other than mortar. Take special precautions in placing and compacting the backfill to avoid any movement of the pipe or damage to the joints. Do not use heavy earth-moving equipment to haul over the structure until a minimum of 4 ft. of permanent or temporary compacted fill has been placed over the structure unless otherwise shown on the plans or permitted in writing. Remove and replace pipe damaged by the Contractor at no expense to the Department.
- 3.2. **Laying Pipe.** Start the laying of pipe on the bedding at the outlet end with the spigot or tongue end pointing downstream, and proceed toward the inlet end with the abutting sections properly matched, true to the established lines and grades unless otherwise authorized. Fit, match, and lay the pipe to form a smooth, uniform conduit. Cut cross trenches in the foundation to allow the barrel of the pipe to rest firmly upon the bedding where bell-and-spigot pipe is used. Cut cross trenches no more than 2 in. larger than the bell ends of the pipe. Lower sections of pipe into the trench without damaging the pipe or disturbing the bedding and the sides of the trench. Carefully clean the ends of the pipe before the pipe is placed. Prevent the earth or bedding material from entering the pipe as it is laid. Lay the pipe in the trench, when elliptical pipe with circular reinforcing or circular pipe with elliptical reinforcing is used, so the markings for the top or bottom are not more than 5° from the vertical plane through the longitudinal axis of the pipe. Remove and re-lay, without extra compensation, pipe that is not in alignment or shows excessive settlement after laying.

Lay multiple lines of reinforced concrete pipe with the centerlines of the individual barrels parallel. Use the clear distances between outer surfaces of adjacent pipes shown in Table 5 unless otherwise shown on the plans. Use the equivalent diameter from Table 2 or Table 3 for arch pipe or horizontal elliptical pipe to determine the clear distance requirement in Table 5.

**Table 5**  
**Minimum Clear Distance between Pipes**

Equivalent Diameter	Min Clear Distance
18 in.	9 in.
24 in.	11 in.
30 in.	1 ft. 1 in.
36 in.	1 ft. 3 in.
42 in.	1 ft. 5 in.
48 in.	1 ft. 7 in.
54 in.	1 ft. 11 in.
60 to 84 in.	2 ft.

3.3. **Jointing.** Make available an appropriate rolling device similar to an automobile mechanic's "creeper" for conveyance through small-size pipe structures.

3.3.1. **Joints Sealed with Hydraulic Cement Mortar.** Use Type S mortar meeting the requirements of ASTM C270. Clean and wet the pipe ends before making the joint. Plaster the lower half of the bell or groove and the upper half of the tongue or spigot with mortar. Pack mortar into the joint from both inside and outside the pipe after the pipes are tightly jointed. Finish the inside smooth and flush with adjacent joints of pipe. Form a bead of semicircular cross-section over tongue-and-groove joints outside the pipe, extending at least 1 in. on each side of the joint. Form the mortar for bell-and-spigot joints to a 45° fillet between the outer edge of the bell and the spigot. Cure mortar joints by keeping the joints wet for at least 48 hr. or until the backfill has been completed, whichever comes first. Place fill or backfill once the mortar jointing material has cured for at least 6 hr. Conduct jointing only when the atmospheric temperature is above 40°F. Protect mortared joints against freezing by backfilling or other approved methods for at least 24 hr.

Driveway culverts do not require mortar banding on the outside of the pipe.

Furnish pipes, with approval, that are large enough for a person to enter with the groove between 1/2 in. and 3/4 in. longer than the tongue. Such pipe may be laid and backfilled without mortar joints. Clean the space on the interior of the pipe between the end of the tongue and the groove of all foreign material, thoroughly wet and fill with mortar around the entire circumference of the pipe, and finish flush after the backfilling has been completed.

3.3.2. **Joints Using Cold-Applied, Plastic Asphalt Sewer Joint Compound.** Ensure both ends of the pipes are clean and dry. Trowel or otherwise place a 1/2-in. thick layer of the compound in the groove end of the pipe covering at least 2/3 of the joint face around the entire circumference. Shove home the tongue end of the next pipe with enough pressure to make a tight joint. Remove any excess mastic projecting into the pipe after the joint is made. Backfill after the joint has been inspected and approved.

3.3.3. **Joints Using Rubber Gaskets.** Make the joint assembly according to the recommendations of the gasket manufacturer. Make joints watertight when using rubber gaskets. Backfill after the joint has been inspected and approved.

3.3.4. **Joints Using Pre-Formed Flexible Joint Sealants.** Install pre-formed flexible joint sealants in accordance with the manufacturer's recommendations. Place the joint sealer so no dirt or other deleterious materials come in contact with the joint sealing material. Pull or push home the pipe with enough force to properly seal the joint. Remove any joint material pushed out into the interior of the pipe that would tend to obstruct the flow. Store pre-formed flexible joint sealants in an area warmed naturally or artificially to above 70°F in an approved manner when the atmospheric temperature is below 60°F. Apply flexible joint sealants to pipe joints immediately before placing pipe in trench, and connect pipe to previously laid pipe. Backfill after the joint has been inspected and approved.

3.4. **Connections and Stub Ends.** Make connections of concrete pipe to existing pipes, pipe storm drains, or storm drain appurtenances as shown on the plans.

Mortar or concrete the bottom of existing structures if necessary to eliminate any drainage pockets created by the connections. Repair any damage to the existing structure resulting from making the connections.

Make connections between concrete pipe and corrugated metal pipe with a suitable concrete collar and a minimum thickness of 4 in. unless otherwise shown on the plans.

Finish stub ends for connections to future work not shown on the plans by installing watertight plugs into the free end of the pipe.

Fill lift holes with concrete, mortar, or precast concrete plugs after the pipe is in place.

---

**4. MEASUREMENT**

This Item will be measured by the foot. Measurement will be made between the ends of the pipe barrel along the flow line, not including safety end treatments. Safety end treatments will be measured in accordance with Item 467, "Safety End Treatment." Pipe that will be jacked, bored, or tunneled will be measured in accordance with Item 476, "Jacking, Boring, or Tunneling Pipe or Box." Measurement of spurs, branches, or new connecting pipe will be made from the intersection of the flow line with the outside surface of the pipe into which it connects. Where inlets, headwalls, catch basins, manholes, junction chambers, or other structures are included in lines of pipe, the length of pipe tying into the structure wall will be included for measurement, but no other portion of the structure length or width will be included.

For multiple pipes, the measured length will be the sum of the lengths of the barrels.

This is a plans quantity measurement Item. The quantity to be paid is the quantity shown in the proposal unless modified by Article 9.2., "Plans Quantity Measurement." Additional measurements or calculations will be made if adjustments of quantities are required.

---

**5. PAYMENT**

The work performed and materials furnished in accordance with this Item and measured as provided under "Measurement" will be paid for at the unit price bid for "Reinforced Concrete Pipe," "Reinforced Concrete Pipe (Arch)," or "Reinforced Concrete Pipe (Elliptical)" of the size and D-load specified or of the size and class specified. This price is full compensation for constructing, furnishing, transporting, placing, and joining pipes; shaping the bed; cutting pipes on skew or slope; connecting to new or existing structures; breaking back, removing, and disposing of portions of the existing structure; replacing portions of the existing structure; cutting pipe ends on skew or slope; and equipment, labor, tools, and incidentals.

Protection methods for excavations greater than 5 ft. deep will be measured and paid for as required under Item 402, "Trench Excavation Protection," or Item 403, "Temporary Special Shoring." Excavation, shaping, bedding, and backfill will be paid for in accordance with Item 400, "Excavation and Backfill for Structures." When jacking, boring, or tunneling is used at the Contractor's option, payment will be made under this Item. When jacking, boring or tunneling is required, payment will be made under Item 476, "Jacking, Boring or Tunneling Pipe or Box."

## Item 479

# Adjusting Manholes and Inlets



### 1. DESCRIPTION

Adjust or cap existing manholes or inlets. Drainage junction boxes will be classified as manholes.

### 2. MATERIALS

Reuse removed manhole and inlet rings, plates, grates, and covers if they are in good condition as determined by the Engineer. Provide additional materials in accordance with Item 465, "Junction Boxes, Manholes, and Inlets," at no cost to the Department. Use single- or multiple-piece prefabricated metal, polymer, plastic, or rubber extension rings for the adjustment of manholes as approved. Limit the height of flexible extension rings to 3 in. Provide concrete that meets Item 421, "Hydraulic Cement Concrete."

Ensure frames and grates, or rings and covers, above grade are of single-piece cast iron manufactured in compliance with Item 471, "Frames, Grates, Rings, and Covers." Provide steel riser material compliant with ASTM A36. Provide steel adjustable risers that include a stainless steel adjustable stud with positive lock that adjusts the diameter  $\pm 3/8$  in. Provide steel risers that include a minimum of 3 allen head set screws that lock the riser to the manhole or catch basin frame. Ensure seating surfaces are flat and true and provide a non-rocking seating surface.

### 3. CONSTRUCTION

Perform all work in accordance with Item 465, "Junction Boxes, Manholes, and Inlets." Excavate and backfill in accordance with Item 400, "Excavation and Backfill for Structures." Carefully remove manhole and inlet rings, covers, plates, and grates to be reused. Clean mortar and grease from the contact areas of all reused items. Dispose of unused removed material as directed. Use construction methods described in Section 479.3.1., "Lowering the Top of a Manhole or Inlet," and Section 479.3.2., "Raising the Top of a Manhole or Inlet," unless otherwise shown on the plans.

- 3.1. **Lowering the Top of a Manhole or Inlet.** Remove a sufficient depth of brick courses or concrete to permit reconstruction on a batter not exceeding 1 in. horizontal to 2 in. vertical. Clean the mortar from the top course of brick where brickwork is present. Rebuild the manhole or inlet to the original top dimensions or to the dimensions shown on the plans. Install the manhole or inlet ring and the cover, plate, or grate to conform to the proposed new surface contour.
- 3.2. **Raising the Top of a Manhole or Inlet.** Clean the top surface of brick or concrete. Construct to the proper new elevation using new rubber extension rings, concrete rings, or Class A concrete. Provide rubber manhole and catch basin risers of minimum 80% by weight recycled rubber and minimum 10% by volume recycled RFL coated fiber. Provide rubber manhole and catch basin adjustment risers that are of uniform quality, free from cracks, holes, and any other surface defects. Construction must be suitable for AASHTO H20 live loads. Load certifications for materials will be made available upon request. Install the manhole or inlet ring and the cover, plate, or grate to conform to the proposed new surface contour. Install prefabricated extension rings in accordance with manufacturer's instructions.
- 3.3. **Capping an Inlet or Manhole.** Remove the inlet or manhole to a minimum of 1 ft. below subgrade elevation or as indicated on the plans. Cap as shown on the plans.

### 4. MEASUREMENT

Adjusted or capped manholes or inlets will be measured as each manhole or inlet adjusted.

---

**5. PAYMENT**

The work performed and materials furnished in accordance with this Item and measured as provided under "Measurement" will be paid for at the unit price bid for "Adjusting Manholes," "Adjusting Inlets," or "Adjusting Manholes and Inlets." This price is full compensation for materials, including backfill as required, and for excavation, tools, equipment, labor, and incidentals.

## Item 502

# Barricades, Signs, and Traffic Handling



### 1. DESCRIPTION

Provide, install, move, replace, maintain, clean, and remove all barricades, signs, cones, lights, and other traffic control devices used for traffic handling as indicated on the plans and as directed.

### 2. CONSTRUCTION

Implement the traffic control plan (TCP) shown on the plans.

Provide traffic control devices that conform to details shown on the plans, the TMUTCD, and the *Compliant Work Zone Traffic Control Device List (CWZTCDL)* maintained by the Traffic Operations Division. In cases of disagreement between these two documents, the CWZTCDL governs over the plans and the TMUTCD governs over both the CWZTCDL and the plans.

Before beginning work, designate in writing, a Contractor's Responsible Person (CRP) and an alternate to be the representative of the Contractor who is responsible for taking or directing corrective measures regarding the TCP. The CRP or designated alternate must be accessible by phone 24 hr. per day and able to respond when notified. The CRP and designated alternate must comply with the requirements of Section 502.2.5., "Training."

Install traffic control devices straight and plumb. Make changes to the TCP only as approved. Minor adjustments to meet field conditions are allowed.

Submit Contractor-proposed TCP changes, signed and sealed by a licensed professional engineer, for approval. The Engineer may develop, sign, and seal Contractor-proposed changes. Changes must conform to guidelines established in the TMUTCD using approved products from the CWZTCDL.

Use fluorescent prismatic reflective sheeting, meeting the requirements of DMS-8300 Type BFL or CFL, for all signs and traffic control devices that have an orange background and a black non-reflective legend on all work zones. Manufacture all signs with a white background and black non-reflective legend using High Specific Intensity sheeting meeting the requirements of DMS-8300 Type A. Orange and white sheeting used on channelizing devices must be manufactured using High Specific Intensity sheeting meeting the requirements of DMS-8300 Type A.

At no time will the Contractor mix Type BFL or CFL fluorescent orange sheeting with orange Type A High Specific Intensity sheeting on the same project. White Engineering Grade (Type A) will not be mixed with white High Specific Intensity (Type A) sheeting.

Maintain traffic control devices by taking corrective action when notified. Corrective actions include, but are not limited to, cleaning, replacing, straightening, covering, and removing devices. Maintain the devices such that they are properly positioned and spaced, legible, and have retroreflective characteristics that meet requirements day or night and in all weather conditions.

- 2.1. **Flaggers.** Designate in writing, a flagging instructor who will serve as a flagging supervisor and is responsible for training and assuring that all flaggers are qualified to perform flagging duties.

Comply with the requirements of Section 502.2.5., "Training." Provide a list of flaggers certified to perform flagging duties.

Flaggers must be courteous and able to effectively communicate with the public. When directing traffic, flaggers must dress appropriately, wear high-visibility safety apparel, use flags, signs, stop-slow paddles, and other hand-signaling devices, and follow the flagging procedures set forth in the TMUTCD.

- 2.2. **Law Enforcement.** Uniformed officers providing work zone traffic services must be trained for the service they perform. Comply with Section 502.2.5., "Training."
- 2.3. **Removal.** Remove all barricades, signs, cones, lights, and other traffic control devices used for work zone traffic handling upon completion of work as shown on the plans or as directed.
- 2.4. **Training.** Workers involved with TCP must be trained using Department-approved training as shown on the plans. Provide a copy of the certification of completion to the Engineer.

---

### 3. MEASUREMENT

Barricades, Signs, and Traffic Handling will be measured by the month. Law enforcement officer and patrol vehicle will be measured by the hour.

---

### 4. PAYMENT

The work performed and materials furnished in accordance with this Item and measured as provided under "Measurement" will be paid for at the unit price bid for "Barricades, Signs, and Traffic Handling." This price is full compensation for installation, maintenance, adjustments, replacements, removal, materials, equipment, labor, tools, and incidentals.

When the plans establish pay items for particular work in the TCP, that work will be measured and paid under pertinent Items.

- 4.1. **Initiation of Payment.** Payment for this Item will begin on the first estimate after barricades, signs, and traffic handling devices have been installed in accordance with the TCP and construction has begun.
- 4.2. **Paid Months.** Monthly payment will be made each succeeding month for this Item provided the barricades, signs, and traffic handling devices have been installed and maintained in accordance with the TCP until the Contract amount has been paid.  
  
If, within the time frame established by the Engineer, the Contractor fails to provide or properly maintain signs and barricades in compliance with the Contract requirements, as determined by the Engineer, the Contractor will be considered in noncompliance with this Item. No payment will be made for the months in question, and the total final payment quantity will be reduced by the number of months the Contractor was in noncompliance.
- 4.3. **Maximum Total Payment Before Acceptance.** The total payment for this Item will not exceed 10% of the total Contract amount before final acceptance in accordance with Article 5.12., "Final Acceptance." The remaining balance will be paid in accordance with Section 502.4.5., "Balance Due."
- 4.4. **Total Payment Quantity.** The quantity paid under this Item will not exceed the total quantity shown on the plans except as modified by change order and as adjusted by Section 502.4.2., "Paid Months." An overrun of the plans quantity for this Item will not be allowed for approving designs; testing; material shortages; closed construction seasons; curing periods; establishment, performance, test, and maintenance periods; failure to complete the work in the number of months allotted; nor delays caused directly or indirectly by requirements of the Contract.
- 4.5. **Balance Due.** The remaining unpaid months of barricades less non-compliance months will be paid on final acceptance of the project, if all work is complete and accepted in accordance with Article 5.12., "Final Acceptance."

4.6.

**Law Enforcement.** The work performed and materials furnished in accordance with this Item and measured as provided under "Measurement," will be paid for at the unit price bid for "Uniformed Police Officer." This price is full compensation for furnishing all labor, materials, supplies, equipment, patrol vehicle, fees, and incidentals necessary to complete the work as directed.

## Item 530

# Intersections, Driveways, and Turnouts



### 1. DESCRIPTION

Construct and pave intersections, driveways, and turnouts. Pave existing intersections, driveways, and turnouts.

Intersections are considered to be areas off the travel lanes and shoulders of the Contract highway on the intersecting highway on the state system. The intersecting on-system highway work will be paid for under this Item only when shown on the plans.

Driveways are defined as private (residential or commercial) and public (county road and city street) access areas off the travel lanes and shoulders.

Turnouts include but are not limited to mailbox and litter barrel widenings.

### 2. MATERIALS

Furnish materials that meet the following:

- Item 247, "Flexible Base"
- Item 260, "Lime Treatment (Road-Mixed)"
- Item 263, "Lime Treatment (Plant-Mixed)"
- Item 275, "Cement Treatment (Road-Mixed)"
- Item 276, "Cement Treatment (Plant-Mixed)"
- Item 292, "Asphalt Treatment (Plant-Mixed)"
- Item 316, "Seal Coat"
- Item 330, "Limestone Rock Asphalt Pavement"
- Item 334, "Hot-Mix Cold-Laid Asphalt Concrete Pavement"
- Item 340, "Dense-Graded Hot-Mix Asphalt (Small Quantity)"
- Item 360, "Concrete Pavement"
- Item 421, "Hydraulic Cement Concrete"
- Item 440, "Reinforcement for Concrete"

### 3. CONSTRUCTION

Construct and pave intersections, driveways, and turnouts, and pave existing intersections, driveways, and turnouts as shown on the plans or as directed. Place materials in accordance with construction Articles of pertinent Items. Provide uninterrupted access to adjacent property unless otherwise directed. Ensure that abrupt elevation changes in driveway or turnout areas that serve as sidewalks do not exceed 1/4 in. and that the sidewalk area cross slope does not exceed 2%. Ready-mix concrete and hand finishing will be permitted when concrete pavement is specified unless otherwise shown on the plans for intersections.

### 4. MEASUREMENT

This Item will be measured by the square yard of the final pavement surface.

---

**5. PAYMENT**

The work performed and materials furnished in accordance with this Item and measured as provided under "Measurement" will be paid for at the unit price bid for "Intersections," "Driveways," "Turnouts," "Intersections, Driveways, and Turnouts," or "Driveways and Turnouts" of the surface specified.

This price is full compensation for furnishing and operating equipment; excavation and embankment; base and pavement materials; and labor, materials, tools and incidentals. Drainage structures will be measured and paid for in accordance with the pertinent bid items.

## Item 506

# Temporary Erosion, Sedimentation, and Environmental Controls



### 1. DESCRIPTION

Install, maintain, and remove erosion, sedimentation, and environmental control measures to prevent or reduce the discharge of pollutants in accordance with the Storm Water Pollution Prevention Plan (SWP3) on the plans and the Texas Pollutant Discharge Elimination System (TPDES) General Permit TXR150000. Control measures are defined as Best Management Practices used to prevent or reduce the discharge of pollutants. Control measures include, but are not limited to, rock filter dams, temporary pipe slope drains, temporary paved flumes, construction exits, earthwork for erosion control, pipe, construction perimeter fence, sandbags, temporary sediment control fence, biodegradable erosion control logs, vertical tracking, temporary or permanent seeding, and other measures. Erosion and sediment control devices must be selected from the *Erosion Control Approved Products* or *Sediment Control Approved Products* lists. Perform work in a manner to prevent degradation of receiving waters, facilitate project construction, and comply with applicable federal, state, and local regulations. Ensure the installation and maintenance of control measures is performed in accordance with the manufacturer's or designer's specifications.

Provide the Contractor Certification of Compliance before performing SWP3 or soil disturbing activities. By signing the Contractor Certification of Compliance, the Contractor certifies they have read and understand the requirements applicable to this project pertaining to the SWP3, the plans, and the TPDES General Permit TXR150000. The Contractor is responsible for any penalties associated with non-performance of installation or maintenance activities required for compliance. Ensure the most current version of the certificate is executed for this project.

### 2. MATERIALS

Furnish materials in accordance with the following:

- Item 161, "Compost"
- Item 432, "Riprap"
- Item 556, "Pipe Underdrains"

#### 2.1. Rock Filter Dams.

2.1.1. **Aggregate.** Furnish aggregate with approved hardness, durability, cleanliness, and resistance to crumbling, flaking, and eroding. Provide the following:

- Types 1, 2, and 4 Rock Filter Dams. Use 3 to 6 in. aggregate.
- Type 3 Rock Filter Dams. Use 4 to 8 in. aggregate.

2.1.2. **Wire.** Provide minimum 20 gauge galvanized wire for the steel wire mesh and tie wires for Types 2 and 3 rock filter dams. Type 4 dams require:

- a double-twisted, hexagonal weave with a nominal mesh opening of 2-1/2 × 3-1/4 in.;
- minimum 0.0866 in. steel wire for netting;
- minimum 0.1063 in. steel wire for selvages and corners; and
- minimum 0.0866 in. for binding or tie wire.

2.1.3. **Sandbag Material.** Furnish sandbags meeting Section 506.2.8., "Sandbags," except that any gradation of aggregate may be used to fill the sandbags.

- 2.2. **Temporary Pipe Slope Drains.** Provide corrugated metal pipe, polyvinyl chloride (PVC) pipe, flexible tubing, watertight connection bands, grommet materials, prefabricated fittings, and flared entrance sections that conform to the plans. Recycled and other materials meeting these requirements are allowed if approved.
- Furnish concrete in accordance with Item 432, "Riprap."
- 2.3. **Temporary Paved Flumes.** Furnish asphalt concrete, hydraulic cement concrete, or other comparable non-erodible material that conforms to the plans. Provide rock or rubble with a minimum diameter of 6 in. and a maximum volume of 1/2 cu. ft. for the construction of energy dissipaters.
- 2.4. **Construction Exits.** Provide materials that meet the details shown on the plans and this Section.
- 2.4.1. **Rock Construction Exit.** Provide crushed aggregate for long- and short-term construction exits. Furnish aggregates that are clean, hard, durable, and free from adherent coatings such as salt, alkali, dirt, clay, loam, shale, soft or flaky materials, and organic and injurious matter. Use 4- to 8-in. aggregate for Type 1. Use 2- to 4-in. aggregate for Type 3.
- 2.4.2. **Timber Construction Exit.** Furnish No. 2 quality or better railroad ties and timbers for long-term construction exits, free of large and loose knots and treated to control rot. Fasten timbers with nuts and bolts or lag bolts, of at least 1/2 in. diameter, unless otherwise shown on the plans or allowed. Provide plywood or pressed wafer board at least 1/2 in. thick for short-term exits.
- 2.4.3. **Foundation Course.** Provide a foundation course consisting of flexible base, bituminous concrete, hydraulic cement concrete, or other materials as shown on the plans or directed.
- 2.5. **Embankment for Erosion Control.** Provide rock, loam, clay, topsoil, or other earth materials that will form a stable embankment to meet the intended use.
- 2.6. **Pipe.** Provide pipe outlet material in accordance with Item 556, "Pipe Underdrains," and details shown on the plans.
- 2.7. **Construction Perimeter Fence.**
- 2.7.1. **Posts.** Provide essentially straight wood or steel posts that are at least 60 in. long. Furnish soft wood posts with a minimum diameter of 3 in., or use nominal 2 × 4 in. boards. Furnish hardwood posts with a minimum cross-section of 1-1/2 × 1-1/5 in. Furnish T- or L-shaped steel posts with a minimum weight of 0.5 lb. per foot.
- 2.7.2. **Fence.** Provide orange construction fencing as approved.
- 2.7.3. **Fence Wire.** Provide 11 gauge or larger galvanized smooth or twisted wire. Provide 16 gauge or larger tie wire.
- 2.7.4. **Flagging.** Provide brightly-colored flagging that is fade-resistant and at least 3/4 in. wide to provide maximum visibility both day and night.
- 2.7.5. **Staples.** Provide staples with a crown at least 1/2 in. wide and legs at least 1/2 in. long.
- 2.7.6. **Used Materials.** Previously used materials meeting the applicable requirements may be used if approved.
- 2.8. **Sandbags.** Provide sandbag material of polypropylene, polyethylene, or polyamide woven fabric with a minimum unit weight of 4 oz. per square yard, a Mullen burst-strength exceeding 300 psi, and an ultraviolet stability exceeding 70%.

Use natural coarse sand or manufactured sand meeting the gradation given in Table 1 to fill sandbags. Filled sandbags must be 24 to 30 in. long, 16 to 18 in. wide, and 6 to 8 in. thick.

**Table 1**  
**Sand Gradation**

Sieve Size	Retained (% by Weight)
#4	Maximum 3%
#100	Minimum 80%
#200	Minimum 95%

Aggregate may be used instead of sand for situations where sandbags are not adjacent to traffic. The aggregate size must not exceed 3/8 in.

- 2.9. **Temporary Sediment Control Fence.** Provide a net-reinforced fence using woven geo-textile fabric. Logos visible to the traveling public will not be allowed.
- 2.9.1. **Fabric.** Provide fabric materials in accordance with DMS-6230, "Temporary Sediment Control Fence Fabric."
- 2.9.2. **Posts.** Provide essentially straight wood or steel posts with a minimum length of 48 in., unless otherwise shown on the plans. Furnish soft wood posts at least 3 in. in diameter, or use nominal 2 x 4 in. boards. Furnish hardwood posts with a minimum cross-section of 1-1/2 x 1-1/2 in. Furnish T- or L-shaped steel posts with a minimum weight of 1.3 lb. per foot.
- 2.9.3. **Net Reinforcement.** Provide net reinforcement of at least 12-1/2 gauge galvanized welded wire mesh, with a maximum opening size of 2 x 4 in., at least 24 in. wide, unless otherwise shown on the plans.
- 2.9.4. **Staples.** Provide staples with a crown at least 3/4 in. wide and legs 1/2 in. long.
- 2.9.5. **Used Materials.** Use recycled material meeting the applicable requirements if approved.
- 2.10. **Biodegradable Erosion Control Logs.**
- 2.10.1. **Core Material.** Furnish core material that is biodegradable or recyclable. Use compost, mulch, aspen excelsior wood fibers, chipped site vegetation, agricultural rice or wheat straw, coconut fiber, 100% recyclable fibers, or any other acceptable material unless specifically called out on the plans. Permit no more than 5% of the material to escape from the containment mesh. Furnish compost meeting the requirements of Item 161, "Compost."
- 2.10.2. **Containment Mesh.** Furnish containment mesh that is 100% biodegradable, photodegradable, or recyclable such as burlap, twine, UV photodegradable plastic, polyester, or any other acceptable material.
- Furnish biodegradable or photodegradable containment mesh when log will remain in place as part of a vegetative system.
- Furnish recyclable containment mesh for temporary installations.
- 2.10.3. **Size.** Furnish biodegradable erosion control logs with diameters shown on the plans or as directed. Stuff containment mesh densely so logs do not deform.

---

### 3. **QUALIFICATIONS, TRAINING, AND EMPLOYEE REQUIREMENTS**

- 3.1. **Contractor Responsible Person Environmental (CRPE) Qualifications and Responsibilities.** Provide and designate in writing at the preconstruction conference a CRPE and alternate CRPE who have overall responsibility for the storm water management program. The CRPE will implement storm water and erosion control practices; will oversee and observe storm water control measure monitoring and management; will monitor the project site daily and produce daily monitoring reports as long as there are BMPs in place or soil disturbing activities are evident to ensure compliance with the SWP3 and TPDES General Permit TXR150000. During time suspensions when work is not occurring or on contract non-work days, daily inspections are not required unless a rain event has occurred. The CRPE will provide recommendations on

how to improve the effectiveness of control measures. Attend the Department's preconstruction conference for the project. Ensure training is completed as identified in Section 506.3.3., "Training," by all applicable personnel before employees work on the project. Document and submit a list, signed by the CRPE, of all applicable Contractor and subcontractor employees who have completed the training. Include the employee's name, the training course name, and date the employee completed the training. Provide the most current list at the preconstruction conference or before SWP3 or soil disturbing activities. Update the list as needed and provide the updated list when updated.

3.2. **Contractor Superintendent Qualifications and Responsibilities.** Provide a superintendent that is competent, has experience with and knowledge of storm water management, and is knowledgeable of the requirements and the conditions of the TPDES General Permit TXR150000. The superintendent will manage and oversee the day to day operations and activities at the project site; work with the CRPE to provide effective storm water management at the project site; represent and act on behalf of the Contractor; and attend the Department's preconstruction conference for the project.

3.3. **Training.** All Contractor and subcontractor employees involved in soil disturbing activities, small or large structures and, SWP3 (storm water control measures, soil retention blankets, seeding, sodding, etc.) activities must complete the following training before performing soil disturbing or SWP3 activities on the project. Training is provided by the Department at no cost to the Contractor and is valid for 3 yr. from the date of completion. The Engineer may require training at a frequency less than 3 yr. based on environmental needs.

- "Environmental Management System: Awareness Training for the Contractor (English and Spanish) (Approximate running time 20 min.)"
- "Storm Water: Environmental Requirements During Construction (English and Spanish) (Approximate running time 20 min.)"

The CRPE, alternate CRPE, Contractor's superintendent, and Contractor and subcontractor lead personnel involved in soil disturbing or SWP3 activities must enroll and complete the training listed below and provide the Certification of Completion before performing soil disturbing or SWP3 activities on the project. Training is provided by a third party and is valid for 3 yr. from the date shown on the Certificate of Completion. Coordinate enrollment through the third party and pay associated fees for the following training:

- "Revegetation During Construction,"
- "Construction General Permit Compliance," and
- "Construction Stage Gate Checklist (CSGC)."

Training may take place at a location at the discretion of the Contractor. Training and associated fees will not be measured or paid for directly but are considered subsidiary to this Item.

---

## 4. CONSTRUCTION

4.1. **Contractor Responsibilities.** Implement the SWP3 for the project site in accordance with the plans and specifications, TPDES General Permit TXR150000, and as directed. Coordinate storm water management with all other work on the project. Develop and implement an SWP3 for project-specific material supply plants within and outside of the Department's right of way in accordance with the specific or general storm water permit requirements. Prevent water pollution from storm water associated with construction activity from entering any surface water or private property on or adjacent to the project site.

4.2. **Implementation.** The CRPE, or alternate CRPE, must be accessible by phone and able to respond to project-related storm water management or other environmental emergencies 24 hr. per day.

4.2.1. **Commencement.** Implement the SWP3 as shown and as directed. Contractor-proposed recommendations for changes will be allowed as approved. Conform to the established guidelines in the TPDES General Permit TXR150000 to make changes. Do not implement changes until approval has been received and changes have been incorporated into the plans. Minor adjustments to meet field conditions are allowed and will be recorded in the SWP3.

- 4.2.2. **Phasing.** Implement control measures before the commencement of activities that result in soil disturbance. Phase and minimize the soil disturbance to the areas shown on the plans. Coordinate temporary control measures with permanent control measures and all other work activities on the project to assure economical, effective, safe, and continuous water pollution prevention. Provide control measures that are appropriate to the construction means, methods, and sequencing allowed by the Contract. Exercise precaution throughout the life of the project to prevent pollution of ground waters and surface waters. Schedule and perform clearing and grubbing operations so that stabilization measures will follow immediately thereafter if project conditions permit. Bring all grading sections to final grade as soon as possible and implement temporary and permanent control measures at the earliest time possible. Implement temporary control measures when required by the TPDES General Permit TXR150000 or otherwise necessitated by project conditions.

Do not prolong final grading and shaping. Preserve vegetation where possible throughout the project, and minimize clearing, grubbing, and excavation within stream banks, bed, and approach sections.

4.3. **General.**

- 4.3.1. **Temporary Alterations or Control Measure Removal.** Altering or removal of control measures is allowed when control measures are restored within the same working day.

- 4.3.2. **Stabilization.** Initiate stabilization for disturbed areas no more than 14 days after the construction activities in that portion of the site have temporarily or permanently ceased. Establish a uniform vegetative cover or use another stabilization practice in accordance with the TPDES General Permit TXR150000.

- 4.3.3. **Finished Work.** Remove and dispose of all temporary control measures upon acceptance of vegetative cover or other stabilization practice unless otherwise directed. Complete soil disturbing activities and establish a uniform perennial vegetative cover. A project will not be considered for acceptance until a vegetative cover of 70% density of existing adjacent undisturbed areas is obtained or equivalent permanent stabilization is obtained in accordance with the TPDES General Permit TXR150000. An exception will be allowed in arid areas as defined in the TPDES General Permit TXR150000.

- 4.3.4. **Restricted Activities and Required Precautions.** Do not discharge onto the ground or surface waters any pollutants such as chemicals, raw sewage, fuels, lubricants, coolants, hydraulic fluids, bitumens, or any other petroleum product. Operate and maintain equipment on-site to prevent actual or potential water pollution. Manage, control, and dispose of litter on-site such that no adverse impacts to water quality occur. Prevent dust from creating a potential or actual unsafe condition, public nuisance, or condition endangering the value, utility, or appearance of any property. Wash out concrete trucks only as described in the TPDES General Permit TXR150000. Use appropriate controls to minimize the offsite transport of suspended sediments and other pollutants if it is necessary to pump or channel standing water (i.e., dewatering). Prevent discharges that would contribute to a violation of Edwards Aquifer Rules, water quality standards, the impairment of a listed water body, or other state or federal law.

- 4.4. **Installation, Maintenance, and Removal Work.** Perform work in accordance with the SWP3, according to manufacturers' guidelines, and in accordance with the TPDES General Permit TXR150000. Install and maintain the integrity of temporary erosion and sedimentation control devices to accumulate silt and debris until soil disturbing activities are completed and permanent erosion control features are in place or the disturbed area has been adequately stabilized as approved.

The Department will inspect and document the condition of the control measures at the frequency shown on the plans and will provide the Construction SWP3 Field Inspection and Maintenance Reports to the Contractor. Make corrections as soon as possible before the next anticipated rain event or within 7 calendar days after being able to enter the worksite for each control measure. The only acceptable reason for not accomplishing the corrections with the time frame specified is when site conditions are "Too Wet to Work." Take immediate action if a correction is deemed critical as directed. When corrections are not made within the established time frame, all work will cease on the project and time charges will continue while the control measures are brought into compliance. Commence work once the Engineer reviews and documents the project is in compliance. Commencing work does not release the Contractor of the liability for noncompliance of the SWP3, plans, or TPDES General Permit TXR150000.

The Engineer may limit the disturbed area if the Contractor cannot control soil erosion and sedimentation resulting from the Contractor's operations. Implement additional controls as directed.

Remove devices upon approval or as directed. Finish-grade and dress the area upon removal. Stabilize disturbed areas in accordance with the permit, and as shown on the plans or directed. Materials removed are considered consumed by the project. Retain ownership of stockpiled material and remove it from the project when new installations or replacements are no longer required.

- 4.4.1. **Rock Filter Dams for Erosion Control.** Remove trees, brush, stumps, and other objectionable material that may interfere with the construction of rock filter dams. Place sandbags as a foundation when required or at the Contractor's option.

Place the aggregate to the lines, height, and slopes specified, without undue voids for Types 1, 2, 3, and 5. Place the aggregate on the mesh and then fold the mesh at the upstream side over the aggregate and secure it to itself on the downstream side with wire ties, or hog rings for Types 2 and 3, or as directed. Place rock filter dams perpendicular to the flow of the stream or channel unless otherwise directed. Construct filter dams according to the following criteria unless otherwise shown on the plans:

- 4.4.1.1. **Type 1 (Non-Reinforced).**

- **Height.** At least 18 in. measured vertically from existing ground to top of filter dam.
- **Top Width.** At least 2 ft.
- **Slopes.** No steeper than 2:1.

- 4.4.1.2. **Type 2 (Reinforced).**

- **Height.** At least 18 in. measured vertically from existing ground to top of filter dam.
- **Top Width.** At least 2 ft.
- **Slopes.** No steeper than 2:1.

- 4.4.1.3. **Type 3 (Reinforced).**

- **Height.** At least 36 in. measured vertically from existing ground to top of filter dam.
- **Top Width.** At least 2 ft.
- **Slopes.** No steeper than 2:1.

- 4.4.1.4. **Type 4 (Sack Gabions).** Unfold sack gabions and smooth out kinks and bends. Connect the sides by lacing in a single loop-double loop pattern on 4- to 5-in. spacing for vertical filling. Pull the end lacing rod at one end until tight, wrap around the end, and twist 4 times. Fill with stone at the filling end, pull the rod tight, cut the wire with approximately 6 in. remaining, and twist wires 4 times.

Place the sack flat in a filling trough, fill with stone, connect sides, and secure ends as described above for horizontal filling.

Lift and place without damaging the gabion. Shape sack gabions to existing contours.

- 4.4.1.5. **Type 5.** Provide rock filter dams as shown on the plans.

- 4.4.2. **Temporary Pipe Slope Drains.** Install pipe with a slope as shown on the plans or as directed. Construct embankment for the drainage system in 8-in. lifts to the required elevations. Hand-tamp the soil around and under the entrance section to the top of the embankment as shown on the plans or as directed. Form the top of the embankment or earth dike over the pipe slope drain at least 1 ft. higher than the top of the inlet pipe at all points. Secure the pipe with hold-downs or hold-down grommets spaced a maximum of 10 ft. on center. Construct the energy dissipaters or sediment traps as shown on the plans or as directed. Construct the sediment trap using concrete or rubble riprap in accordance with Item 432, "Riprap," when designated on the plans.

- 4.4.3. **Temporary Paved Flumes.** Construct paved flumes as shown on the plans or as directed. Provide excavation and embankment (including compaction of the subgrade) of material to the dimensions shown on the plans unless otherwise indicated. Install a rock or rubble riprap energy dissipater, constructed from the materials specified above, to a minimum depth of 9 in. at the flume outlet to the limits shown on the plans or as directed.
- 4.4.4. **Construction Exits.** Prevent traffic from crossing or exiting the construction site or moving directly onto a public roadway, alley, sidewalk, parking area, or other right of way areas other than at the location of construction exits when tracking conditions exist. Construct exits for either long- or short-term use.
- 4.4.4.1. **Long-Term.** Place the exit over a foundation course as required. Grade the foundation course or compacted subgrade to direct runoff from the construction exits to a sediment trap as shown on the plans or as directed. Construct exits with a width of at least 14 ft. for one-way and 20 ft. for two-way traffic for the full width of the exit, or as directed.
- 4.4.4.1.1. **Type 1.** Construct to a depth of at least 8 in. using crushed aggregate as shown on the plans or as directed.
- 4.4.4.1.2. **Type 2.** Construct using railroad ties and timbers as shown on the plans or as directed.
- 4.4.4.2. **Short-Term.**
- 4.4.4.2.1. **Type 3.** Construct using crushed aggregate, plywood, or wafer board. This type of exit may be used for daily operations where long-term exits are not practical.
- 4.4.4.2.2. **Type 4.** Construct as shown on the plans or as directed.
- 4.4.5. **Earthwork for Erosion Control.** Perform excavation and embankment operations to minimize erosion and to remove collected sediments from other erosion control devices.
- 4.4.5.1. **Excavation and Embankment for Erosion Control Features.** Place earth dikes, swales, or combinations of both along the low crown of daily lift placement, or as directed, to prevent runoff spillover. Place swales and dikes at other locations as shown on the plans or as directed to prevent runoff spillover or to divert runoff. Construct cuts with the low end blocked with undisturbed earth to prevent erosion of hillsides. Construct sediment traps at drainage structures in conjunction with other erosion control measures as shown on the plans or as directed.
- Create a sediment basin, where required, providing 3,600 cu. ft. of storage per acre drained, or equivalent control measures for drainage locations that serve an area with 10 or more disturbed acres at one time, not including offsite areas.
- 4.4.5.2. **Excavation of Sediment and Debris.** Remove sediment and debris when accumulation affects the performance of the devices, after a rain, and when directed.
- 4.4.6. **Construction Perimeter Fence.** Construct, align, and locate fencing as shown on the plans or as directed.
- 4.4.6.1. **Installation of Posts.** Embed posts 18 in. deep or adequately anchor in rock, with a spacing of 8 to 10 ft.
- 4.4.6.2. **Wire Attachment.** Attach the top wire to the posts at least 3 ft. from the ground. Attach the lower wire midway between the ground and the top wire.
- 4.4.6.3. **Flag Attachment.** Attach flagging to both wire strands midway between each post. Use flagging at least 18 in. long. Tie flagging to the wire using a square knot.
- 4.4.7. **Sandbags for Erosion Control.** Construct a berm or dam of sandbags that will intercept sediment-laden storm water runoff from disturbed areas, create a retention pond, detain sediment, and release water in sheet flow. Fill each bag with sand so that at least the top 6 in. of the bag is unfilled to allow for proper tying of the

open end. Place the sandbags with their tied ends in the same direction. Offset subsequent rows of sandbags 1/2 the length of the preceding row. Place a single layer of sandbags downstream as a secondary debris trap. Place additional sandbags as necessary or as directed for supplementary support to berms or dams of sandbags or earth.

4.4.8. **Temporary Sediment-Control Fence.** Provide temporary sediment-control fence near the downstream perimeter of a disturbed area to intercept sediment from sheet flow. Incorporate the fence into erosion-control measures used to control sediment in areas of higher flow. Install the fence as shown on the plans, as specified in this Section, or as directed.

4.4.8.1. **Installation of Posts.** Embed posts at least 18 in. deep, or adequately anchor, if in rock, with a spacing of 6 to 8 ft. and install on a slight angle toward the runoff source.

4.4.8.2. **Fabric Anchoring.** Dig trenches along the uphill side of the fence to anchor 6 to 8 in. of fabric. Provide a minimum trench cross-section of 6 × 6 in. Place the fabric against the side of the trench and align approximately 2 in. of fabric along the bottom in the upstream direction. Backfill the trench, then hand-tamp.

4.4.8.3. **Fabric and Net Reinforcement Attachment.** Attach the reinforcement to wooden posts with staples, or to steel posts with T-clips, in at least 4 places equally spaced unless otherwise shown on the plans. Sewn vertical pockets may be used to attach reinforcement to end posts. Fasten the fabric to the top strand of reinforcement by hog rings or cord every 15 in. or less.

4.4.8.4. **Fabric and Net Splices.** Locate splices at a fence post with a minimum lap of 6 in. attached in at least 6 places equally spaced unless otherwise shown on the plans. Do not locate splices in concentrated flow areas.

Requirements for installation of used temporary sediment-control fence include the following:

- fabric with minimal or no visible signs of biodegradation (weak fibers),
- fabric without excessive patching (more than 1 patch every 15 to 20 ft.),
- posts without bends, and
- backing without holes.

4.4.9. **Biodegradable Erosion Control Logs.** Install biodegradable erosion control logs near the downstream perimeter of a disturbed area to intercept sediment from sheet flow. Incorporate the biodegradable erosion control logs into the erosion measures used to control sediment in areas of higher flow. Install, align, and locate the biodegradable erosion control logs as specified below, as shown on the plans, or as directed.

Secure biodegradable erosion control logs in a method adequate to prevent displacement as a result of normal rain events, prevent damage to the logs, and as approved, such that flow is not allowed under the logs. Temporarily removing and replacing biodegradable erosion logs as to facilitate daily work is allowed at the Contractor's expense.

4.4.10. **Vertical Tracking.** Perform vertical tracking on slopes to temporarily stabilize soil. Provide equipment with a track undercarriage capable of producing a linear soil impression measuring a minimum of 12 in. long × 2 to 4 in. wide × 1/2 to 2 in. deep. Do not exceed 12 in. between track impressions. Install continuous linear track impressions where the 12 in. length impressions are perpendicular to the slope. Vertical tracking is required on projects where soil disturbing activities have occurred unless otherwise approved.

4.5. **Monitoring and Documentation.** Monitor the control measures on a daily basis as long as there are BMPs in place and/or soil disturbing activities are evident to ensure compliance with the SWP3 and TPDES General Permit TXR150000. During time suspensions when work is not occurring or contract non-work days, daily inspections are not required unless a rain event has occurred. Monitoring will consist of, but is not limited to, observing, inspecting, and documenting site locations with control measures and discharge points to provide maintenance and inspection of controls as described in the SWP3. Keep written records of daily monitoring. Document in the daily monitoring report the control measure condition, the date of inspection, required corrective actions, responsible person for making the corrections, and the date corrective actions

were completed. Maintain records of all monitoring reports at the project site or at an approved place. Provide copies within 7 days. Together, the CRPE and an Engineer's representative will complete the Construction Stage Gate Checklist on a periodic basis as directed.

---

## 5. MEASUREMENT

- 5.1. **Rock Filter Dams.** Installation or removal of rock filter dams will be measured by the foot or by the cubic yard. The measured volume will include sandbags, when used.
- 5.1.1. **Linear Measurement.** When rock filter dams are measured by the foot, measurement will be along the centerline of the top of the dam.
- 5.1.2. **Volume Measurement.** When rock filter dams are measured by the cubic yard, measurement will be based on the volume of rock computed by the method of average end areas.
- 5.1.2.1. **Installation.** Measurement will be made in final position.
- 5.1.2.2. **Removal.** Measurement will be made at the point of removal.
- 5.2. **Temporary Pipe Slope Drains.** Temporary pipe slope drains will be measured by the foot.
- 5.3. **Temporary Paved Flumes.** Temporary paved flumes will be measured by the square yard of surface area. The measured area will include the energy dissipater at the flume outlet.
- 5.4. **Construction Exits.** Construction exits will be measured by the square yard of surface area.
- 5.5. **Earthwork for Erosion and Sediment Control.**
- 5.5.1. **Equipment and Labor Measurement.** Equipment and labor used will be measured by the actual number of hours the equipment is operated and the labor is engaged in the work.
- 5.5.2. **Volume Measurement.**
- 5.5.2.1. **In Place.**
- 5.5.2.1.1. **Excavation.** Excavation will be measured by the cubic yard in its original position and the volume computed by the method of average end areas.
- 5.5.2.1.2. **Embankment.** Embankment will be measured by the cubic yard in its final position by the method of average end areas. The volume of embankment will be determined between:
- the original ground surfaces or the surface upon that the embankment is to be constructed for the feature and
  - the lines, grades and slopes of the accepted embankment for the feature.
- 5.5.2.2. **In Vehicles.** Excavation and embankment quantities will be combined and paid for under "Earthwork (Erosion and Sediment Control, In Vehicle)." Excavation will be measured by the cubic yard in vehicles at the point of removal. Embankment will be measured by the cubic yard in vehicles measured at the point of delivery. Shrinkage or swelling factors will not be considered in determining the calculated quantities.
- 5.6. **Construction Perimeter Fence.** Construction perimeter fence will be measured by the foot.
- 5.7. **Sandbags for Erosion Control.** Sandbags will be measured as each sandbag or by the foot along the top of sandbag berms or dams.

- 5.8. **Temporary Sediment-Control Fence.** Installation or removal of temporary sediment-control fence will be measured by the foot.
- 5.9. **Biodegradable Erosion Control Logs.** Installation or removal of biodegradable erosion control logs will be measured by the foot along the centerline of the top of the control logs.
- 5.10. **Vertical Tracking.** Vertical tracking will not be measured or paid for directly but is considered subsidiary to this Item.

---

## 6. PAYMENT

The following will not be paid for directly but are subsidiary to pertinent Items:

- erosion-control measures for Contractor project-specific locations (PSLs) inside and outside the right of way (such as construction and haul roads, field offices, equipment and supply areas, plants, and material sources);
- removal of litter, unless a separate pay item is shown on the plans;
- repair to devices and features damaged by Contractor operations;
- added measures and maintenance needed due to negligence, carelessness, lack of maintenance, and failure to install permanent controls;
- removal and reinstallation of devices and features needed for the convenience of the Contractor;
- finish grading and dressing upon removal of the device; and
- minor adjustments including but not limited to plumbing posts, reattaching fabric, minor grading to maintain slopes on an erosion embankment feature, or moving small numbers of sandbags.

Stabilization of disturbed areas will be paid for under pertinent Items except vertical tacking which is subsidiary.

Furnishing and installing pipe for outfalls associated with sediment traps and ponds will not be paid for directly but is subsidiary to the excavation and embankment under this Item.

- 6.1. **Rock Filter Dams.** The work performed and materials furnished in accordance with this Item and measured as provided under "Measurement" will be paid for at the unit price bid as follows:
- 6.1.1. **Installation.** Installation will be paid for as "Rock Filter Dams (Install)" of the type specified. This price is full compensation for furnishing and operating equipment, finish backfill and grading, lacing, proper disposal, labor, materials, tools, and incidentals.
- 6.1.2. **Removal.** Removal will be paid for as "Rock Filter Dams (Remove)." This price is full compensation for furnishing and operating equipment, proper disposal, labor, materials, tools, and incidentals.

When the Engineer directs that the rock filter dam installation or portions thereof be replaced, payment will be made at the unit price bid for "Rock Filter Dams (Remove)" and for "Rock Filter Dams (Install)" of the type specified. This price is full compensation for furnishing and operating equipment, finish backfill and grading, lacing, proper disposal, labor, materials, tools, and incidentals.

- 6.2. **Temporary Pipe Slope Drains.** The work performed and materials furnished in accordance with this Item and measured as provided under "Measurement" will be paid for at the unit price bid for "Temporary Pipe Slope Drains" of the size specified. This price is full compensation for furnishing materials, removal and disposal, furnishing and operating equipment, labor, tools, and incidentals.

Removal of temporary pipe slope drains will not be paid for directly but is subsidiary to the installation Item. When the Engineer directs that the pipe slope drain installation or portions thereof be replaced, payment will be made at the unit price bid for "Temporary Pipe Slope Drains" of the size specified, which is full compensation for the removal and reinstallation of the pipe drain.

Earthwork required for the pipe slope drain installation, including construction of the sediment trap, will be measured and paid for under "Earthwork for Erosion and Sediment Control."

Riprap concrete or stone, when used as an energy dissipater or as a stabilized sediment trap, will be measured and paid for in accordance with Item 432, "Riprap."

- 6.3. **Temporary Paved Flumes.** The work performed and materials furnished in accordance with this Item and measured as provided under "Measurement" will be paid for at the unit price bid for "Temporary Paved Flume (Install)" or "Temporary Paved Flume (Remove)." This price is full compensation for furnishing and placing materials, removal and disposal, equipment, labor, tools, and incidentals.

When the Engineer directs that the paved flume installation or portions thereof be replaced, payment will be made at the unit prices bid for "Temporary Paved Flume (Remove)" and "Temporary Paved Flume (Install)." These prices are full compensation for the removal and replacement of the paved flume and for equipment, labor, tools, and incidentals.

Earthwork required for the paved flume installation, including construction of a sediment trap, will be measured and paid for under "Earthwork for Erosion and Sediment Control."

- 6.4. **Construction Exits.** Contractor-required construction exits from off right of way locations or on-right of way PSLs will not be paid for directly but are subsidiary to pertinent Items.

The work performed and materials furnished in accordance with this Item and measured as provided under "Measurement" for construction exits needed on right of way access to work areas required by the Department will be paid for at the unit price bid for "Construction Exits (Install)" of the type specified or "Construction Exits (Remove)." This price is full compensation for furnishing and placing materials, excavating, removal and disposal, cleaning vehicles, labor, tools, and incidentals.

When the Engineer directs that a construction exit or portion thereof be removed and replaced, payment will be made at the unit prices bid for "Construction Exit (Remove)" and "Construction Exit (Install)" of the type specified. These prices are full compensation for the removal and replacement of the construction exit and for equipment, labor, tools, and incidentals.

Construction of sediment traps used in conjunction with the construction exit will be measured and paid for under "Earthwork for Erosion and Sediment Control."

- 6.5. **Earthwork for Erosion and Sediment Control.**

- 6.5.1. **Initial Earthwork for Erosion and Sediment Control.** The work performed and materials furnished in accordance with this Item and measured as provided under "Measurement" will be paid for at the unit price bid for "Excavation (Erosion and Sediment Control, In Place)," "Embankment (Erosion and Sediment Control, In Place)," "Excavation (Erosion and Sediment Control, In Vehicle)," "Embankment (Erosion and Sediment Control, In Vehicle)," or "Earthwork (Erosion and Sediment Control, In Vehicle)."

This price is full compensation for excavation and embankment including hauling, disposal of material not used elsewhere on the project; embankments including furnishing material from approved sources and construction of erosion-control features; and equipment, labor, tools, and incidentals.

Sprinkling and rolling required by this Item will not be paid for directly but will be subsidiary to this Item.

- 6.5.2. **Maintenance Earthwork for Erosion and Sediment Control for Cleaning and Restoring Control Measures.** The work performed and materials furnished in accordance with this Item and measured as provided under "Measurement" will be paid under a Contractor Force Account Item from invoice provided to the Engineer.

This price is full compensation for excavation, embankment, and re-grading including removal of accumulated sediment in various erosion control installations as directed, hauling, and disposal of material not used elsewhere on the project; excavation for construction of erosion-control features; embankments including furnishing material from approved sources and construction of erosion-control features; and equipment, labor, tools, and incidentals.

Earthwork needed to remove and obliterate erosion-control features will not be paid for directly but is subsidiary to pertinent Items unless otherwise shown on the plans.

Sprinkling and rolling required by this Item will not be paid for directly but will be subsidiary to this Item.

- 6.6. **Construction Perimeter Fence.** The work performed and materials furnished in accordance with this Item and measured as provided under "Measurement" will be paid for at the unit price bid for "Construction Perimeter Fence." This price is full compensation for furnishing and placing the fence; digging, fence posts, wire, and flagging; removal and disposal; and materials, equipment, labor, tools, and incidentals.

Removal of construction perimeter fence will not be paid for directly but is subsidiary to the installation Item. When the Engineer directs that the perimeter fence installation or portions thereof be removed and replaced, payment will be made at the unit price bid for "Construction Perimeter Fence," which is full compensation for the removal and reinstallation of the construction perimeter fence.

- 6.7. **Sandbags for Erosion Control.** Sandbags will be paid for at the unit price bid for "Sandbags for Erosion Control" (of the height specified when measurement is by the foot). This price is full compensation for materials, placing sandbags, removal and disposal, equipment, labor, tools, and incidentals.

Removal of sandbags will not be paid for directly but is subsidiary to the installation Item. When the Engineer directs that the sandbag installation or portions thereof be replaced, payment will be made at the unit price bid for "Sandbags for Erosion Control," which is full compensation for the reinstallation of the sandbags.

- 6.8. **Temporary Sediment-Control Fence.** The work performed and materials furnished in accordance with this Item and measured as provided under "Measurement" will be paid for at the unit price bid as follows:

- 6.8.1. **Installation.** Installation will be paid for as "Temporary Sediment-Control Fence (Install)." This price is full compensation for furnishing and operating equipment finish backfill and grading, lacing, proper disposal, labor, materials, tools, and incidentals.

- 6.8.2. **Removal.** Removal will be paid for as "Temporary Sediment-Control Fence (Remove)." This price is full compensation for furnishing and operating equipment, proper disposal, labor, materials, tools, and incidentals.

- 6.9. **Biodegradable Erosion Control Logs.** The work performed and materials furnished in accordance with this Item and measured as provided under "Measurement" will be paid for at the unit price bid as follows:

- 6.9.1. **Installation.** Installation will be paid for as "Biodegradable Erosion Control Logs (Install)" of the size specified. This price is full compensation for furnishing and operating equipment finish backfill and grading, staking, proper disposal, labor, materials, tools, and incidentals.

- 6.9.2. **Removal.** Removal will be paid for as "Biodegradable Erosion Control Logs (Remove)." This price is full compensation for furnishing and operating equipment, proper disposal, labor, materials, tools, and incidentals.

- 6.10. **Vertical Tracking.** Vertical tracking will not be measured or paid for directly but is considered subsidiary to this Item.



**GENERAL NOTES AND  
STANDARD SPECIFICATIONS**

- 3.3.4. **Cement-Stabilized Backfill.** Backfill the excavation to the elevations shown with cement-stabilized backfill when shown on the plans. Use cement-stabilized backfill that contains aggregate conforming to the gradation limits shown in Table 1, water, and a minimum of 7% hydraulic cement based on the dry weight of the aggregate, in accordance with Tex-120-E.

Place cement-stabilized backfill equally along the sides of structures to prevent strain on or displacement of the structure. Fill voids when placing cement-stabilized backfill. Use hand-operated tampers if necessary to fill voids.

- 3.3.5. **Flowable Backfill.** Backfill the excavation with flowable backfill to the elevations indicated when shown on the plans. Prevent the structure from being displaced during the placement of the flowable fill, and prevent flowable fill from entering manholes/inlets and culverts, and drainage structures.

---

#### 4. MEASUREMENT

This is a plans quantity measurement item. The quantity to be paid is the quantity shown in the proposal, unless modified by Article 9.2., "Plans Quantity Measurement." Additional measurements or calculations will be made if adjustments of quantities are required.

- 4.1. **Structural Excavation.** Unless shown on the plans as a pay item, structural excavation quantities shown are for information purposes only.

When structural excavation is specified as a pay item, structural excavation for pipe headwalls, inlets, manholes, culvert or storm drain extensions less than 15 ft. long, bridge abutments, retaining walls, and side road and private entrance pipe culverts will not be measured. No allowance will be made for variance from plans quantity incurred by an alternate bid.

When specified as a pay item, structural excavation will be measured by the cubic yard as computed by the average end areas method. Excavation diagrams on the plans take precedence over the provisions of this Article.

- 4.1.1. **Boundaries of Measurement.**

- 4.1.1.1. **Pipe.**

- 4.1.1.1.1. **Pipe up to 42 inches.** For pipe up to 42 in. nominal or equivalent diameter, no material outside of vertical planes 1 ft. beyond and parallel to the horizontal projection of the outside surfaces of the pipe will be included.

- 4.1.1.1.2. **Pipe Larger than 42 inches.** For pipes larger than 42 in. nominal or equivalent diameter, no material outside of vertical planes located 2 ft. beyond and parallel to the horizontal projection of the outside surfaces of the pipe will be included.

Quantities for excavation in fill above natural ground include 1 ft. above the top of the pipe regardless of the height of completed fill. Excavation for pipe will be measured between the extreme ends of the completed structure including end appurtenances as shown on the plans and from centerline to centerline of inlets, manholes, etc.

- 4.1.1.2. **Structural Plate Structures.** No material outside of vertical planes 3 ft. beyond and parallel to the horizontal projection of the outside surfaces of the structure will be included. When the quality of the existing soil or embankment is less than that of the proposed backfill material, the limits of measurement will be extended to vertical planes located 1/2 of the span beyond the horizontal projection of the outside surfaces of the structure.

- 4.1.1.3. **Footings, Walls, Boxes, and Other Excavation.** No material outside of vertical planes 1 ft. beyond and parallel to the edges of the footings or outside walls will be included whether or not a cofferdam or shoring is

ITEM 247. Flexible Base

Flexible Base Type E will be composed of caliche (argillaceous Limestone, calcareous or calcareous clay particles) and may contain stone, conglomerate, gravel, sand or granular materials when these materials are in situ with the caliche.

Blended material for Flexible Base TY E GR 4

The Contractor may blend base material with another caliche source or with crushed concrete, meeting the requirements for TY "E" materials, provided a minimum of 50% caliche is used. The crushed concrete may contain sand or granular materials. Stabilizing additives will not be allowed in the raw crushed concrete base. Acceptance will be under the following conditions:

Condition One (1): When both components of the blend in their individual stockpiles meet all the physical requirements of this Item, then field blending will be allowed.

Condition Two (2): When only one component of the blend passes the physical requirements of this Item, the materials shall be blended through a plant for stockpile testing and approval.

Flexible Base (TY E GR 4) shall conform to the following requirements:

BEFORE LIME IS ADDED

Retained on Sq. Sieve	Percent Retained
2"	0
1/2"	20-60
No. 4	40-75
No. 40	70-90
Max. PI:	15
Max. Wet Ball PI:	15
Wet Ball Mill Max Amount:	50
Min. Comp. Strength PSI:	150 at 15 PSI lateral pressure
Triaxial Test	Tex-117-E

The Wet Ball Test (Tex-116-E) shall be run and the Plasticity Index of the material passing the No. 40 sieve shall be determined (Wet Ball PI).

After 1% lime (laboratory) is added to unlimed material

Max PI	12
Min. Comp. Strength PSI:	180 at 15 PSI Lateral Pressure
Triaxial Test (Lime Treated)	Tex-121-E

# GOVERNING SPECIFICATIONS AND SPECIAL PROVISIONS

All specifications and special provisions applicable to this project are identified as follows:

**STANDARD SPECIFICATIONS:** Adopted by the Texas Department of Transportation, June 1, 2004. Standard Specifications are incorporated into the contract by reference.

*Example:*

ITEM 247	FLEXIBLE BASE (204)
ITEM 502	BARRICADES, SIGNS AND TRAFFIC HANDLING
ITEM 530	DRIVEWAYS AND TURNOUTS
ITEM 5010	CONSTRUCTION EXITS

**SPECIAL PROVISIONS:** Special Provisions will govern and take precedence over the Specifications enumerated hereon wherever in conflict therewith. (Enclosed herewith)

**General:** The above listed specifications items are those under which payment is to be made. These, together with such other pertinent items, if any, as may be referred to in the above-listed specification items, and including the special provisions listed above, constitute the complete specifications for this project.

All item numbers noted in these plans are the same as those referenced in the Texas Department of Transportation 2004 Standard Specifications for Construction and Maintenance of Highways, Streets, and Bridges book (June 1, 2004)

**Certification  
Regarding Debarment, Suspension and Ineligibility**

As is required by the Federal Regulations Implementing Executive Order 12549, Debarment and Suspension, 45 CFR Part 76, Government-wide Debarment and Suspension, the applicant certifies, to the best of his or her knowledge and belief, that both it and its principals:

- a. Are not presently debarred, suspended, proposed for debarment, declared ineligible, or voluntarily excluded from participation in this transaction by any federal department or agency;
- b. Have not within a three-year period preceding this bid proposal and/or application been convicted of or had a civil judgment rendered against them for commission of fraud or a criminal offense in connection with obtaining, attempting to obtain, or performing a public (federal, state, or local) transaction or contract under a public transaction, violation of federal or state antitrust statutes or commission of embezzlement, theft, forgery, bribery, falsification or destruction of records, making false statements, or receiving stolen property;
- c. Are not presently indicted for or otherwise criminally or civilly charged by a government entity with commission of any of the offenses enumerated herein; and
- d. Have not within a three-year period preceding this bid proposal and/or application had one or more public transactions terminated for cause or default.

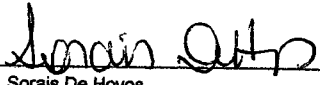
Signature:   
Print Name: Sorais De Hoyos  
Title: Managing Member  
Telephone Number: (956) 212-8226  
Date: 07 / 11 / 2017

If the bidder is unable to certify to all of the statements in this Certification, such bidder should attach an explanation to this proposal.

## Request for Taxpayer Identification Number and Certification

**Give Form to the  
requester. Do not  
send to the IRS.**

Print or type See Specific Instructions on page 2.	1 Name (as shown on your income tax return). Name is required on this line; do not leave this line blank. <b>Five Star Galaxy Construction LLC</b>		
	2 Business name/disregarded entity name, if different from above		
	3 Check appropriate box for federal tax classification; check only one of the following seven boxes: <input type="checkbox"/> Individual/sole proprietor or single-member LLC <input checked="" type="checkbox"/> Limited liability company. Enter the tax classification (C=C corporation, S=S corporation, P=partnership) ▶ <b>C</b> <small>Note. For a single-member LLC that is disregarded, do not check LLC; check the appropriate box in the line above for the tax classification of the single-member owner.</small> <input type="checkbox"/> Other (see instructions) ▶		4 Exemptions (codes apply only to certain entities, not individuals; see instructions on page 3): Exempt payee code (if any) _____ Exemption from FATCA reporting code (if any) _____ <small>(Applies to accounts maintained outside the U.S.)</small>
	5 Address (number, street, and apt. or suite no.) <b>4012 S Cesar Chavez Rd</b>		Requester's name and address (optional)
	6 City, state, and ZIP code <b>San Juan, TX 78589</b>		
	7 List account number(s) here (optional)		

### Part I Taxpayer Identification Number (TIN)

Enter your TIN in the appropriate box. The TIN provided must match the name given on line 1 to avoid backup withholding. For individuals, this is generally your social security number (SSN). However, for a resident alien, sole proprietor, or disregarded entity, see the Part I instructions on page 3. For other entities, it is your employer identification number (EIN). If you do not have a number, see *How to get a TIN* on page 3.

**Note.** If the account is in more than one name, see the instructions for line 1 and the chart on page 4 for guidelines on whose number to enter.

<b>Social security number</b>										
OR										
<b>Employer identification number</b>										
4	7		-	3	5	5	1	0	9	2

### Part II Certification

Under penalties of perjury, I certify that:

1. The number shown on this form is my correct taxpayer identification number (or I am waiting for a number to be issued to me); and
2. I am not subject to backup withholding because: (a) I am exempt from backup withholding, or (b) I have not been notified by the Internal Revenue Service (IRS) that I am subject to backup withholding as a result of a failure to report all interest or dividends, or (c) the IRS has notified me that I am no longer subject to backup withholding; and
3. I am a U.S. citizen or other U.S. person (defined below); and
4. The FATCA code(s) entered on this form (if any) indicating that I am exempt from FATCA reporting is correct.

**Certification instructions.** You must cross out item 2 above if you have been notified by the IRS that you are currently subject to backup withholding because you have failed to report all interest and dividends on your tax return. For real estate transactions, item 2 does not apply. For mortgage interest paid, acquisition or abandonment of secured property, cancellation of debt, contributions to an individual retirement arrangement (IRA), and generally, payments other than interest and dividends, you are not required to sign the certification, but you must provide your correct TIN. See the instructions on page 3.

<b>Sign Here</b>	Signature of U.S. person ▶ <i>Sorais De Hoyos</i>	Date ▶ 05/22/2017
------------------	---	-------------------

### General Instructions

Section references are to the Internal Revenue Code unless otherwise noted.

**Future developments.** Information about developments affecting Form W-9 (such as legislation enacted after we release it) is at [www.irs.gov/fw9](http://www.irs.gov/fw9).

#### Purpose of Form

An individual or entity (Form W-9 requester) who is required to file an information return with the IRS must obtain your correct taxpayer identification number (TIN) which may be your social security number (SSN), individual taxpayer identification number (ITIN), adoption taxpayer identification number (ATIN), or employer identification number (EIN), to report on an information return the amount paid to you, or other amount reportable on an information return. Examples of information returns include, but are not limited to, the following:

- Form 1099-INT (interest earned or paid)
- Form 1099-DIV (dividends, including those from stocks or mutual funds)
- Form 1099-MISC (various types of income, prizes, awards, or gross proceeds)
- Form 1099-B (stock or mutual fund sales and certain other transactions by brokers)
- Form 1099-S (proceeds from real estate transactions)
- Form 1099-K (merchant card and third party network transactions)

- Form 1098 (home mortgage interest), 1098-E (student loan interest), 1098-T (tuition)
- Form 1099-C (canceled debt)
- Form 1099-A (acquisition or abandonment of secured property)

Use Form W-9 only if you are a U.S. person (including a resident alien), to provide your correct TIN.

*If you do not return Form W-9 to the requester with a TIN, you might be subject to backup withholding. See What is backup withholding? on page 2.*

By signing the filled-out form, you:

1. Certify that the TIN you are giving is correct (or you are waiting for a number to be issued),
2. Certify that you are not subject to backup withholding, or
3. Claim exemption from backup withholding if you are a U.S. exempt payee. If applicable, you are also certifying that as a U.S. person, your allocable share of any partnership income from a U.S. trade or business is not subject to the withholding tax on foreign partners' share of effectively connected income, and
4. Certify that FATCA code(s) entered on this form (if any) indicating that you are exempt from the FATCA reporting, is correct. See *What is FATCA reporting?* on page 2 for further information.

- The U.S. grantor or other owner of a grantor trust and not the trust, and
- The U.S. trust (other than a grantor trust) and not the beneficiaries of the trust.

**Foreign person.** If you are a foreign person, do not use Form W-9. Instead, use the appropriate Form W-8 (see Publication 515, Withholding of Tax on Nonresident Aliens and Foreign Entities).

**Nonresident alien who becomes a resident alien.**

Generally, only a nonresident alien individual may use the terms of a tax treaty to reduce or eliminate U.S. tax on certain types of income. However, most tax treaties contain a provision known as a "saving clause." Exceptions specified in the saving clause may permit an exemption from tax to continue for certain types of income even after the recipient has otherwise become a U.S. resident alien for tax purposes.

If you are a U.S. resident alien who is relying on an exception contained in the saving clause of a tax treaty to claim an exemption from U.S. tax on certain types of income, you must attach a statement to Form W-9 that specifies the following five items:

1. The treaty country. Generally, this must be the same treaty under which you claimed exemption from tax as a nonresident alien.
2. The treaty article addressing the income.
3. The article number (or location) in the tax treaty that contains the saving clause and its exceptions.
4. The type and amount of income that qualifies for the exemption from tax.
5. Sufficient facts to justify the exemption from tax under the terms of the treaty article.

**Example.** Article 20 of the U.S.-China income tax treaty allows an exemption from tax for scholarship income received by a Chinese student temporarily present in the United States. Under U.S. law, this student will become a resident alien for tax purposes if his or her stay in the United States exceeds 5 calendar years. However, paragraph 2 of the first Protocol to the U.S.-China treaty (dated April 30, 1984) allows the provisions of Article 20 to continue to apply even after the Chinese student becomes a resident alien of the United States. A Chinese student who qualifies for this exception (under paragraph 2 of the first protocol) and is relying on this exception to claim an exemption from tax on his or her scholarship or fellowship income would attach to Form W-9 a statement that includes the information described above to support that exemption.

If you are a nonresident alien or a foreign entity not subject to backup withholding, give the requester the appropriate completed Form W-8.

**What is backup withholding?** Persons making certain payments to you must under certain conditions withhold and pay to the IRS 28% of such payments (after December 31, 2002). This is called "backup withholding." Payments that may be subject to backup withholding include interest, dividends, broker and barter exchange transactions, rents, royalties, nonemployee pay, and certain payments from fishing boat operators. Real estate transactions are not subject to backup withholding.

You will not be subject to backup withholding on payments you receive if you give the requester your correct TIN, make the proper certifications, and report all your taxable interest and dividends on your tax return.

**Payments you receive will be subject to backup withholding if:**

1. You do not furnish your TIN to the requester,
2. You do not certify your TIN when required (see the Part II instructions on page 4 for details),

3. The IRS tells the requester that you furnished an incorrect TIN,

4. The IRS tells you that you are subject to backup withholding because you did not report all your interest and dividends on your tax return (for reportable interest and dividends only), or

5. You do not certify to the requester that you are not subject to backup withholding under 4 above (for reportable interest and dividend accounts opened after 1983 only).

Certain payees and payments are exempt from backup withholding. See the instructions below and the separate Instructions for the Requester of Form W-9.

Also see *Special rules regarding partnerships* on page 1.

## Penalties

**Failure to furnish TIN.** If you fail to furnish your correct TIN to a requester, you are subject to a penalty of \$50 for each such failure unless your failure is due to reasonable cause and not to willful neglect.

**Civil penalty for false information with respect to withholding.** If you make a false statement with no reasonable basis that results in no backup withholding, you are subject to a \$500 penalty.

**Criminal penalty for falsifying information.** Willfully falsifying certifications or affirmations may subject you to criminal penalties including fines and/or imprisonment.

**Misuse of TINs.** If the requester discloses or uses TINs in violation of federal law, the requester may be subject to civil and criminal penalties.

## Specific Instructions

### Name

If you are an individual, you must generally enter the name shown on your income tax return. However, if you have changed your last name, for instance, due to marriage without informing the Social Security Administration of the name change, enter your first name, the last name shown on your social security card, and your new last name.

If the account is in joint names, list first, and then circle, the name of the person or entity whose number you entered in Part I of the form.

**Sole proprietor.** Enter your individual name as shown on your income tax return on the "Name" line. You may enter your business, trade, or "doing business as (DBA)" name on the "Business name" line.

**Limited liability company (LLC).** If you are a single-member LLC (including a foreign LLC with a domestic owner) that is disregarded as an entity separate from its owner under Treasury regulations section 301.7701-3, enter the owner's name on the "Name" line. Enter the LLC's name on the "Business name" line. Check the appropriate box for your filing status (sole proprietor, corporation, etc.), then check the box for "Other" and enter "LLC" in the space provided.

**Other entities.** Enter your business name as shown on required federal tax documents on the "Name" line. This name should match the name shown on the charter or other legal document creating the entity. You may enter any business, trade, or DBA name on the "Business name" line.

**Note.** You are requested to check the appropriate box for your status (individual/sole proprietor, corporation, etc.).

## Exempt From Backup Withholding

If you are exempt, enter your name as described above and check the appropriate box for your status, then check the "Exempt from backup withholding" box in the line following the business name, sign and date the form.

Generally, individuals (including sole proprietors) are not exempt from backup withholding. Corporations are exempt from backup withholding for certain payments, such as interest and dividends.

**Note.** If you are exempt from backup withholding, you should still complete this form to avoid possible erroneous backup withholding.

**Exempt payees.** Backup withholding is not required on any payments made to the following payees:

1. An organization exempt from tax under section 501(a), any IRA, or a custodial account under section 403(b)(7) if the account satisfies the requirements of section 401(f)(2),
  2. The United States or any of its agencies or instrumentalities,
  3. A state, the District of Columbia, a possession of the United States, or any of their political subdivisions or instrumentalities,
  4. A foreign government or any of its political subdivisions, agencies, or instrumentalities, or
  5. An international organization or any of its agencies or instrumentalities.
- Other payees that may be exempt from backup withholding include:
6. A corporation,
  7. A foreign central bank of issue,
  8. A dealer in securities or commodities required to register in the United States, the District of Columbia, or a possession of the United States,
  9. A futures commission merchant registered with the Commodity Futures Trading Commission,
  10. A real estate investment trust,
  11. An entity registered at all times during the tax year under the Investment Company Act of 1940,
  12. A common trust fund operated by a bank under section 584(a),
  13. A financial institution,
  14. A middleman known in the investment community as a nominee or custodian, or
  15. A trust exempt from tax under section 664 or described in section 4947.

The chart below shows types of payments that may be exempt from backup withholding. The chart applies to the exempt recipients listed above, 1 through 15.

IF the payment is for . . .	THEN the payment is exempt for . . .
Interest and dividend payments	All exempt recipients except for 9
Broker transactions	Exempt recipients 1 through 13. Also, a person registered under the Investment Advisers Act of 1940 who regularly acts as a broker
Barter exchange transactions and patronage dividends	Exempt recipients 1 through 5
Payments over \$600 required to be reported and direct sales over \$5,000 <sup>1</sup>	Generally, exempt recipients 1 through 7 <sup>2</sup>

<sup>1</sup> See Form 1099-MISC, Miscellaneous Income, and its instructions.

<sup>2</sup> However, the following payments made to a corporation (including gross proceeds paid to an attorney under section 6045(f), even if the attorney is a corporation) and reportable on Form 1099-MISC are not exempt from backup withholding: medical and health care payments, attorneys' fees; and payments for services paid by a federal executive agency.

## Part I. Taxpayer Identification Number (TIN)

**Enter your TIN in the appropriate box.** If you are a resident alien and you do not have and are not eligible to get an SSN, your TIN is your IRS individual taxpayer identification number (ITIN). Enter it in the social security number box. If you do not have an ITIN, see *How to get a TIN* below.

If you are a sole proprietor and you have an EIN, you may enter either your SSN or EIN. However, the IRS prefers that you use your SSN.

If you are a single-owner LLC that is disregarded as an entity separate from its owner (see *Limited liability company (LLC)* on page 2), enter your SSN (or EIN, if you have one). If the LLC is a corporation, partnership, etc., enter the entity's EIN.

**Note.** See the chart on page 4 for further clarification of name and TIN combinations.

**How to get a TIN.** If you do not have a TIN, apply for one immediately. To apply for an SSN, get Form SS-5, Application for a Social Security Card, from your local Social Security Administration office or get this form online at [www.socialsecurity.gov](http://www.socialsecurity.gov). You may also get this form by calling 1-800-772-1213. Use Form W-7, Application for IRS Individual Taxpayer Identification Number, to apply for an ITIN, or Form SS-4, Application for Employer Identification Number, to apply for an EIN. You can apply for an EIN online by accessing the IRS website at [www.irs.gov/businesses](http://www.irs.gov/businesses) and clicking on Employer ID Numbers under Related Topics. You can get Forms W-7 and SS-4 from the IRS by visiting [www.irs.gov](http://www.irs.gov) or by calling 1-800-TAX-FORM (1-800-829-3676).

If you are asked to complete Form W-9 but do not have a TIN, write "Applied For" in the space for the TIN, sign and date the form, and give it to the requester. For interest and dividend payments, and certain payments made with respect to readily tradable instruments, generally you will have 60 days to get a TIN and give it to the requester before you are subject to backup withholding on payments. The 60-day rule does not apply to other types of payments. You will be subject to backup withholding on all such payments until you provide your TIN to the requester.

**Note.** Writing "Applied For" means that you have already applied for a TIN or that you intend to apply for one soon.

**Caution:** A disregarded domestic entity that has a foreign owner must use the appropriate Form W-8.

## Part II. Certification

To establish to the withholding agent that you are a U.S. person, or resident alien, sign Form W-9. You may be requested to sign by the withholding agent even if items 1, 4, and 5 below indicate otherwise.

For a joint account, only the person whose TIN is shown in Part I should sign (when required). Exempt recipients, see *Exempt From Backup Withholding* on page 2.

**Signature requirements.** Complete the certification as indicated in 1 through 5 below.

**1. Interest, dividend, and barter exchange accounts opened before 1984 and broker accounts considered active during 1983.** You must give your correct TIN, but you do not have to sign the certification.

**2. Interest, dividend, broker, and barter exchange accounts opened after 1983 and broker accounts considered inactive during 1983.** You must sign the certification or backup withholding will apply. If you are subject to backup withholding and you are merely providing your correct TIN to the requester, you must cross out item 2 in the certification before signing the form.

**3. Real estate transactions.** You must sign the certification. You may cross out item 2 of the certification.

**4. Other payments.** You must give your correct TIN, but you do not have to sign the certification unless you have been notified that you have previously given an incorrect TIN. "Other payments" include payments made in the course of the requester's trade or business for rents, royalties, goods (other than bills for merchandise), medical and health care services (including payments to corporations), payments to a nonemployee for services, payments to certain fishing boat crew members and fishermen, and gross proceeds paid to attorneys (including payments to corporations).

**5. Mortgage interest paid by you, acquisition or abandonment of secured property, cancellation of debt, qualified tuition program payments (under section 529), IRA, Coverdell ESA, Archer MSA or HSA contributions or distributions, and pension distributions.** You must give your correct TIN, but you do not have to sign the certification.

## What Name and Number To Give the Requester

For this type of account:	Give name and SSN of:
1. Individual	The individual
2. Two or more individuals (joint account)	The actual owner of the account or, if combined funds, the first individual on the account <sup>1</sup>
3. Custodian account of a minor (Uniform Gift to Minors Act)	The minor <sup>2</sup>
4. a. The usual revocable savings trust (grantor is also trustee)	The grantor-trustee <sup>1</sup>
b. So-called trust account that is not a legal or valid trust under state law	The actual owner <sup>1</sup>
5. Sole proprietorship or single-owner LLC	The owner <sup>3</sup>
For this type of account:	Give name and EIN of:
6. Sole proprietorship or single-owner LLC	The owner <sup>3</sup>
7. A valid trust, estate, or pension trust	Legal entity <sup>4</sup>
8. Corporate or LLC electing corporate status on Form 8832	The corporation
9. Association, club, religious, charitable, educational, or other tax-exempt organization	The organization
10. Partnership or multi-member LLC	The partnership
11. A broker or registered nominee	The broker or nominee
12. Account with the Department of Agriculture in the name of a public entity (such as a state or local government, school district, or prison) that receives agricultural program payments	The public entity

<sup>1</sup> List first and circle the name of the person whose number you furnish. If only one person on a joint account has an SSN, that person's number must be furnished.

<sup>2</sup> Circle the minor's name and furnish the minor's SSN.

<sup>3</sup> You must show your individual name and you may also enter your business or "DBA" name on the second name line. You may use either your SSN or EIN (if you have one). If you are a sole proprietor, IRS encourages you to use your SSN.

<sup>4</sup> List first and circle the name of the legal trust, estate, or pension trust. (Do not furnish the TIN of the personal representative or trustee unless the legal entity itself is not designated in the account title.) Also see *Special rules regarding partnerships* on page 1.

**Note.** If no name is circled when more than one name is listed, the number will be considered to be that of the first name listed.

## Privacy Act Notice

Section 6109 of the Internal Revenue Code requires you to provide your correct TIN to persons who must file information returns with the IRS to report interest, dividends, and certain other income paid to you, mortgage interest you paid, the acquisition or abandonment of secured property, cancellation of debt, or contributions you made to an IRA, or Archer MSA or HSA. The IRS uses the numbers for identification purposes and to help verify the accuracy of your tax return. The IRS may also provide this information to the Department of Justice for civil and criminal litigation, and to cities, states, the District of Columbia, and U.S. possessions to carry out their tax laws. We may also disclose this information to other countries under a tax treaty, to federal and state agencies to enforce federal nontax criminal laws, or to federal law enforcement and intelligence agencies to combat terrorism.

You must provide your TIN whether or not you are required to file a tax return. Payers must generally withhold 28% of taxable interest, dividend, and certain other payments to a payee who does not give a TIN to a payer. Certain penalties may also apply.

EXHIBIT E

HIDALGO COUNTY  
PURCHASING DEPARTMENT  
Bidder/Vendor Application

Complete in print or type. Please return this application to the Hidalgo County Purchasing Department  
thru Facsimile: (956) 318-2629 or (956) 292-7612  
in person or regular mail to: 2812 S. Business Hwy. 281 , Edinburg, Texas 78539  
or e-mail: purchasing@co.hidalgo.tx.us

Company Name: Five Star Galaxy Construction LLC		Telephone No. ( 956 ) 212-8226
dba Name:		
Legal Name: Five Star Galaxy Construction LLC		
Mailing Address:	Fax No. ( 956 ) 800-4551	
Physical Address: 4012 S Cesar Chavez Rd		
City, State, Zip: San Juan, TX 78589	Tax I.D. No. 47-3551092	
Remit to Address: 4012 S Cesar Chavez Rd	City, State, Zip San Juan, TX 78589	
E-Mail Address: Hugo@fivestargalaxyconstruction.com		
Representative(s) Name(s) & Title(s) Sorais De Hoyos/Owner		
Type of Organization (check one): <input type="checkbox"/> Individual <input type="checkbox"/> Partnership <input type="checkbox"/> Corporation <input type="checkbox"/> Non-Profit <input checked="" type="checkbox"/> LLC <input type="checkbox"/> Sole Proprietor <input type="checkbox"/> Other, Specify _____		
State Identification No. _____ (Please attached completed W-9 form with this application) Federal Identification No. or (if individual) SS No. _____		
State of Incorporation: _____ Date: _____ Other: _____		
Type of Business (check one): <input type="checkbox"/> Manufacturer <input type="checkbox"/> Wholesaler <input type="checkbox"/> Retailer <input type="checkbox"/> Broker <input type="checkbox"/> Distributor <input type="checkbox"/> Service Organization <input checked="" type="checkbox"/> Other, Specify Construction		
Name & Title of Person(s) Authorized to Sign Bids, Proposals, and/or Contracts: Sorais De Hoyos/Owner		
Small and/or Disadvantaged Business Information (check application criteria)		
Small Business: _____ Disadvantaged Business (At Least 51% Ownership)		
<input type="checkbox"/> Less than 125,000 annual gross receipt	<input type="checkbox"/> Black American	<input type="checkbox"/> Native American
<input type="checkbox"/> Less than 250,000 annual gross receipt	<input checked="" type="checkbox"/> Hispanic American	<input checked="" type="checkbox"/> Women
<input checked="" type="checkbox"/> Less than 499,000 annual gross receipt	<input type="checkbox"/> Asian Pacific American	<input type="checkbox"/> Other
<input type="checkbox"/> More than 500,000 annual gross receipt		
Have you been certified as a HUB or an MBE/WBE source?: <input type="checkbox"/> Yes <input checked="" type="checkbox"/> No		
Indicate Certification No.(s): _____ or are Certificate(s) attached?: <input type="checkbox"/> Yes <input type="checkbox"/> No		
What type of product(s) is/are solicited by your company?: Sitework and Paving Services		
Would you like to be provided with specifications for procurements of such products?: <input type="checkbox"/> Yes <input checked="" type="checkbox"/> No		
To Be Completed by the County: Rec'd by (Purchasing): _____ Date Rec'd by (Purchasing): _____		
Date Forwarded Information to Auditor's Office: _____ Entry Date: _____ Vendor No.: _____		

**HISTORICALLY UNDERUTILIZED BUSINESS (HUB) DECLARATION**

The primary objective of the Hidalgo County HUB Program is to ensure Historically Underutilized Businesses receive a fair and equal opportunity for participation in the County's procurement process. This fact holds true for Services (Professional & Non-Professional), Commodities, and Construction contracts and any subcontracts thereto. The program strongly encourages Prime Contractors to provide subcontracting opportunities to Certified Hub Contractors/Vendors. Our goal for HUB contractor/vendor participation, as well as HUB subcontractor participation is 30%. To be considered as a "Certified HUB Contractor/Vendor" the contractor/vendor must have been certified by, and hold a current and valid certification with any of the three agencies listed below.

Have you been Certified as a HUB or an MBE/WBE source?:  Yes  No

If yes, by whom?:  Texas Building & Procurement Commission  Other \_\_\_\_\_

Indicate Certification No(s): \_\_\_\_\_ or Are Certificate(s) Attached?:  Yes  No

---

**LIST OF CERTIFIED HUB SUBCONTRACTORS**

(Attach additional pages if necessary)

What percentage of the Bid, RFP, or RFQ is to be subcontracted with Certified HUB sources?: \_\_\_\_\_%  
(List HUB Subcontractor information below).

HUB Subcontractor Name: \_\_\_\_\_ HUB Status: \_\_\_\_\_  
Certifying Agency (Check all applicable):  Texas Building & Procurement Commission  Other \_\_\_\_\_  
Address: \_\_\_\_\_ City: \_\_\_\_\_ State: \_\_\_\_\_ Zip: \_\_\_\_\_  
Contact Person: \_\_\_\_\_ Title: \_\_\_\_\_ Phone No.: ( ) \_\_\_\_\_  
Subcontract Amount: \$ \_\_\_\_\_ Description of Work to be Performed: \_\_\_\_\_

---

HUB Subcontractor Name: \_\_\_\_\_ HUB Status: \_\_\_\_\_  
Certifying Agency (Check all applicable):  Texas Building & Procurement Commission  Other \_\_\_\_\_  
Address: \_\_\_\_\_ City: \_\_\_\_\_ State: \_\_\_\_\_ Zip: \_\_\_\_\_  
Contact Person: \_\_\_\_\_ Title: \_\_\_\_\_ Phone No.: ( ) \_\_\_\_\_  
Subcontract Amount: \$ \_\_\_\_\_ Description of Work to be Performed: \_\_\_\_\_

---

HUB Subcontractor Name: \_\_\_\_\_ HUB Status: \_\_\_\_\_  
Certifying Agency (Check all applicable):  Texas Building & Procurement Commission  Other \_\_\_\_\_  
Address: \_\_\_\_\_ City: \_\_\_\_\_ State: \_\_\_\_\_ Zip: \_\_\_\_\_  
Contact Person: \_\_\_\_\_ Title: \_\_\_\_\_ Phone No.: ( ) \_\_\_\_\_  
Subcontract Amount: \$ \_\_\_\_\_ Description of Work to be Performed: \_\_\_\_\_

---

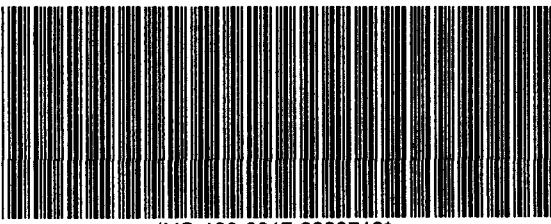

\*VG-120-2017-2839719\*

Hidalgo County  
Arturo Guajardo Jr.  
County Clerk  
Edinburg, Texas 78540

Document No: 2839719

Billable Pages: 1

Recorded On: August 11, 2017 04:10 PM

Number of Pages: 2

\*\*\*\*\*Examined and Charged as Follows\*\*\*\*\*

Total Recording: \$ 36.00

\*\*\*\*\*THIS PAGE IS PART OF THE DOCUMENT\*\*\*\*\*

Any provision herein which restricts the Sale, Rental, or use of the described REAL PROPERTY because of color or race is invalid and unenforceable under federal law.

**File Information:**

Document No: 2839719  
Receipt No: 20170811000362  
Recorded On: August 11, 2017 04:10 PM  
Deputy Clerk: Mary Lou Cantu  
Station: CH-1-CC-K15

**Record and Return To:**

Five Star Galaxy Construction LLC  
4012 SouthCesar Chavez Rd  
San Juan TX 78589

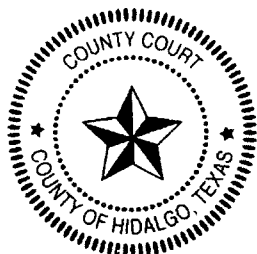

STATE OF TEXAS  
COUNTY OF HIDALGO

I hereby certify that this Instrument was FILED in the File Number sequence on the date/time printed hereon, and was duly RECORDED in the Official Records of Hidalgo County, Texas.

Arturo Guajardo Jr.  
County Clerk  
Hidalgo County, Texas

# CONFLICT OF INTEREST QUESTIONNAIRE

For vendor doing business with local governmental entity

## FORM CIQ

**This questionnaire reflects changes made to the law by H.B. 23, 84th Leg., Regular Session.**

This questionnaire is being filed in accordance with Chapter 176, Local Government Code, by a vendor who has a business relationship as defined by Section 176.001(1-a) with a local governmental entity and the vendor meets requirements under Section 176.006(a).

By law this questionnaire must be filed with the records administrator of the local governmental entity not later than the 7th business day after the date the vendor becomes aware of facts that require the statement to be filed. See Section 176.006(a-1), Local Government Code.

A vendor commits an offense if the vendor knowingly violates Section 176.006, Local Government Code. An offense under this section is a misdemeanor.

OFFICE USE ONLY
Date Received

**1 Name of vendor who has a business relationship with local governmental entity.**

FIVE STAR GALAXY CONSTRUCTION, LLC.

**2**  Check this box if you are filing an update to a previously filed questionnaire. (The law requires that you file an updated completed questionnaire with the appropriate filing authority not later than the 7th business day after the date on which you became aware that the originally filed questionnaire was incomplete or inaccurate.)

**3 Name of local government officer about whom the information is being disclosed.**

N/A

\_\_\_\_\_  
Name of Officer

**4 Describe each employment or other business relationship with the local government officer, or a family member of the officer, as described by Section 176.003(a)(2)(A). Also describe any family relationship with the local government officer. Complete subparts A and B for each employment or business relationship described. Attach additional pages to this Form CIQ as necessary.**

A. Is the local government officer or a family member of the officer receiving or likely to receive taxable income, other than investment income, from the vendor?

Yes  No

B. Is the vendor receiving or likely to receive taxable income, other than investment income, from or at the direction of the local government officer or a family member of the officer AND the taxable income is not received from the local governmental entity?

Yes  No

**5 Describe each employment or business relationship that the vendor named in Section 1 maintains with a corporation or other business entity with respect to which the local government officer serves as an officer or director, or holds an ownership interest of one percent or more.**

NONE

**6**  Check this box if the vendor has given the local government officer or a family member of the officer one or more gifts as described in Section 176.003(a)(2)(B), excluding gifts described in Section 176.003(a-1).

**7**

Sorais De Hoyos  
Signature of vendor doing business with the governmental entity

August 11, 2017  
Date

# CERTIFICATE OF INTERESTED PARTIES

FORM 1295

1 of 1

Complete Nos. 1 - 4 and 6 if there are interested parties.  
 Complete Nos. 1, 2, 3, 5, and 6 if there are no interested parties.

## OFFICE USE ONLY CERTIFICATION OF FILING

Certificate Number:  
 2017-256153

Date Filed:  
 09/01/2017

Date Acknowledged:  
 09/21/2017

**1 Name of business entity filing form, and the city, state and country of the business entity's place of business.**

Five Star Galaxy Construction, LLC  
 San Juan, TX United States

**2 Name of governmental entity or state agency that is a party to the contract for which the form is being filed.**

Hidalgo County Precinct 1

**3 Provide the identification number used by the governmental entity or state agency to track or identify the contract, and provide a description of the services, goods, or other property to be provided under the contract.**

C-CAP-17-186-08-08  
 Paving improvements

4	Name of Interested Party	City, State, Country (place of business)	Nature of interest (check applicable)	
			Controlling	Intermediary

**5 Check only if there is NO Interested Party.**

**6 AFFIDAVIT**

I swear, or affirm, under penalty of perjury, that the above disclosure is true and correct.

\_\_\_\_\_  
 Signature of authorized agent of contracting business entity

AFFIX NOTARY STAMP / SEAL ABOVE

Sworn to and subscribed before me, by the said \_\_\_\_\_, this the \_\_\_\_\_ day of \_\_\_\_\_, 20\_\_\_\_\_, to certify which, witness my hand and seal of office.

\_\_\_\_\_  
 Signature of officer administering oath

\_\_\_\_\_  
 Printed name of officer administering oath

\_\_\_\_\_  
 Title of officer administering oath

# CERTIFICATE OF INTERESTED PARTIES

FORM 1295

1 of 1

Complete Nos. 1 - 4 and 6 if there are interested parties.  
Complete Nos. 1, 2, 3, 5, and 6 if there are no interested parties.

## OFFICE USE ONLY CERTIFICATION OF FILING

1 Name of business entity filing form, and the city, state and country of the business entity's place of business.  
Five Star Galaxy Construction, LLC  
San Juan, TX United States

Certificate Number:  
2017-256153

Date Filed:  
09/01/2017

2 Name of governmental entity or state agency that is a party to the contract for which the form is being filed.  
Hidalgo County Precinct 1

Date Acknowledged:

3 Provide the identification number used by the governmental entity or state agency to track or identify the contract, and provide a description of the services, goods, or other property to be provided under the contract.  
C-CAP-17-186-08-08  
Paving improvements

4	Name of Interested Party	City, State, Country (place of business)	Nature of interest (check applicable)	
			Controlling	Intermediary
	Sorais De Hoyos	San Juan TX. United States	✓	

5 Check only if there is NO interested Party.

### 6 AFFIDAVIT

I swear, or affirm, under penalty of perjury, that the above disclosure is true and correct.



Sorais De Hoyos  
Signature of authorized agent of contracting business entity

AFFIX NOTARY STAMP / SEAL ABOVE

Sworn to and subscribed before me, by the said Sorais De Hoyos, this the 1<sup>st</sup> day of September, 20 17, to certify which, witness my hand and seal of office.

Krista Garcia Krista Garcia Notary  
Signature of officer administering oath Printed name of officer administering oath Title of officer administering oath

## **CONFLICT OF INTEREST QUESTIONNAIRE**

### **For vendor doing business with local governmental entity**

A complete copy of Chapter 176 of the Local Government Code may be found at <http://www.statutes.legis.state.tx.us/Docs/LG/htm/LG.176.htm>. For easy reference, below are some of the sections cited on this form.

**Local Government Code § 176.001(1-a):** "Business relationship" means a connection between two or more parties based on commercial activity of one of the parties. The term does not include a connection based on:

- (A) a transaction that is subject to rate or fee regulation by a federal, state, or local governmental entity or an agency of a federal, state, or local governmental entity;
- (B) a transaction conducted at a price and subject to terms available to the public; or
- (C) a purchase or lease of goods or services from a person that is chartered by a state or federal agency and that is subject to regular examination by, and reporting to, that agency.

**Local Government Code § 176.003(a)(2)(A) and (B):**

(a) A local government officer shall file a conflicts disclosure statement with respect to a vendor if:

\*\*\*

(2) the vendor:

(A) has an employment or other business relationship with the local government officer or a family member of the officer that results in the officer or family member receiving taxable income, other than investment income, that exceeds \$2,500 during the 12-month period preceding the date that the officer becomes aware that

(i) a contract between the local governmental entity and vendor has been executed;

or

(ii) the local governmental entity is considering entering into a contract with the vendor;

(B) has given to the local government officer or a family member of the officer one or more gifts that have an aggregate value of more than \$100 in the 12-month period preceding the date the officer becomes aware that:

(i) a contract between the local governmental entity and vendor has been executed; or

(ii) the local governmental entity is considering entering into a contract with the vendor.

**Local Government Code § 176.006(a) and (a-1)**

(a) A vendor shall file a completed conflict of interest questionnaire if the vendor has a business relationship with a local governmental entity and:

(1) has an employment or other business relationship with a local government officer of that local governmental entity, or a family member of the officer, described by Section 176.003(a)(2)(A);

(2) has given a local government officer of that local governmental entity, or a family member of the officer, one or more gifts with the aggregate value specified by Section 176.003(a)(2)(B), excluding any gift described by Section 176.003(a-1); or

(3) has a family relationship with a local government officer of that local governmental entity.

(a-1) The completed conflict of interest questionnaire must be filed with the appropriate records administrator not later than the seventh business day after the later of:

(1) the date that the vendor:

(A) begins discussions or negotiations to enter into a contract with the local governmental entity; or

(B) submits to the local governmental entity an application, response to a request for proposals or bids, correspondence, or another writing related to a potential contract with the local governmental entity; or

(2) the date the vendor becomes aware:

(A) of an employment or other business relationship with a local government officer, or a family member of the officer, described by Subsection (a);

(B) that the vendor has given one or more gifts described by Subsection (a); or

(C) of a family relationship with a local government officer.

**SALES TAX AND LOCAL SALES TAX  
EXEMPTION CERTIFICATE FOR CONTRACTORS**

This Contract is to be performed for an exempt organization as defined by Article 20.04 (H) (4) of the Texas Limited Sales, Excise, and Use Tax Act and the undersigned hereby claims an exemption from payment of taxes under Chapter 20, title 122A, revised hereby claims an exemption from payment of taxes under Chapter 20, title 122A, revised civil statues of Texas, and Article 1066 ©, entitle Local Sales and Use Tax, revised civil statues of Texas.

The Contractor performing this Contract may purchase, rent, or lease all materials, supplies, equipment used for consumed in the performance of this Contract by issuing to his retailer an exemption certificate in lieu of the tax, said exemption certificate complying with State Comptroller's Ruling No 95-9.07. Any such exemption certificate issue by the Contractor in lieu of the tax shall be subject to the provisions of the State Comptroller's Ruling No. 95.0.09 as amended to be effective October 2, 1968.

EXECUTED this the 11<sup>th</sup> day of July, 2017.

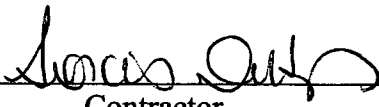
  
Contractor

# Registration Complete for Five Star Galaxy Construction LLC / 080689663

notification@sam.gov

Mon 5/29/2017 9:07 PM

To: Hugo Dehoyos <hugo@fivestargalaxyconstruction.com>;

*This email was sent by an automated administrator. Please do not reply to this message.*

Dear Sorais De Hoyos,

Congratulations! You have successfully completed the registration process for Five Star Galaxy Construction LLC / 080689663 in the U.S. federal government's System for Award Management (SAM).

What happens next?

Your SAM registration will go through an external validation process with the Internal Revenue Service (if applicable) and the Defense Logistics Agency's Commercial and Government Entity (CAGE) Code system.

You will receive another e-mail from SAM.gov once your IRS and/or CAGE validations are complete, which can take up to 10 business days. Until then, you will not be eligible for contracts, assistance awards, or to do business with the Federal government, as determined by your Entity's profile.

Please note:

-- If your registration fails the IRS validation step, you will receive an email from SAM.gov with information on next steps needed from you to complete validation.

-- If you receive a supplemental email from an "@dla.mil" address regarding issues with your entity and CAGE Code, be sure to follow their instructions critical to passing CAGE validation. CAGE will contact your entity's Government Business Point of Contact as listed in your registration.

Checking the Status of your SAM Registration

You may check on the status of your registration at any time by logging into [www.sam.gov](http://www.sam.gov) and clicking on your Entity Record page. In addition, be sure to check your spam email folder for any communications from SAM, IRS and/or DLA related to your entity's registration. Remember CAGE will contact your Government Business POC and not your SAM Entity Administrator.

Additional questions?

If you have not received another email from SAM.gov and it has been more than 10 business days, you may contact the Federal Service Desk (FSD):

-- Submit a question FSD explaining your issue and an agent will respond by email, during normal business hours - Monday through Friday, 8 a.m. to 8 p.m. ET.

-- Phone toll-free: U.S. callers, 866-606-8220; international callers, 334-206-7828; U.S. military, via DSN: 866-606-8220.

Thank you,

The System for Award Management (SAM) Administrator

<https://www.sam.gov/portal/public/SAM>

OTHER RELEVANT INFORMATION related to your registration:

What is a CAGE Code?

Learn more about CAGE Codes and how they are assigned here:

[https://www.fsd.gov/app/answers/detail/a\\_id/186/kw/cage](https://www.fsd.gov/app/answers/detail/a_id/186/kw/cage)

What is CAGE validation?

When you submit your registration in SAM, it is forwarded to CAGE for additional review and validation. If the data you submitted passes all CAGE edits, the registration will be processed automatically and returned to SAM with minimal processing time. This occurs for the majority of

<https://outlook.office.com/owa/?realm=k12.wv.us&path=/mail/search>

GOVERNMENT CODE

CHAPTER 2258. PREVAILING WAGE RATES

SUBCHAPTER A. GENERAL PROVISIONS

§Sec. 2258.001. DEFINITIONS. In this chapter:

(1) "Locality in which the work is performed" means:

(A) for a contract for a public work awarded by the state, the political subdivision of the state in which the public work is located:

(i) which may include a county, municipality, county and municipality, or district, except as provided by Subparagraph (ii); and

(ii) which, in a municipality with a population of 500,000 or more, may only include the geographic limits of the municipality; or

(B) for a contract for a public work awarded by a political subdivision of the state, the geographical limits of the political subdivision.

(2) "Public body" means a public body awarding a contract for a public work on behalf of the state or a political subdivision of the state.

(3) "Worker" includes a laborer or mechanic.

Added by Acts 1995, 74th Leg., ch. 76, Sec. 5.49(a), eff. Sept. 1, 1995. Amended by Acts 2001, 77th Leg., ch. 1422, Sec. 14.04, eff. Sept. 1, 2001.

§Sec. 2258.002. APPLICABILITY OF CHAPTER TO PUBLIC WORKS. (a) This chapter applies only to the construction of a public work, including a building, highway, road, excavation, and repair work or other project development or improvement, paid for in whole or in part from public funds, without regard to whether the work is done under public supervision or direction.

(b) This chapter does not apply to work done directly by a public utility company under an order of a public authority.

Added by Acts 1995, 74th Leg., ch. 76, Sec. 5.49(a), eff. Sept. 1, 1995.

§Sec. 2258.003. LIABILITY. An officer, agent, or employee of a public body is not liable in a civil action for any act or omission implementing or enforcing this chapter unless the action was made in bad faith.

Added by Acts 1995, 74th Leg., ch. 76, Sec. 5.49(a), eff. Sept. 1, 1995.

SUBCHAPTER B. PAYMENT OF PREVAILING WAGE RATES

§Sec. 2258.021. RIGHT TO BE PAID PREVAILING WAGE RATES. (a) A worker employed on a public work by or on behalf of the state or a political subdivision of the state shall be paid:

(1) not less than the general prevailing rate of per diem wages for work of a similar

character in the locality in which the work is performed; and

(2) not less than the general prevailing rate of per diem wages for legal holiday and overtime work.

(b) Subsection (a) does not apply to maintenance work.

(c) A worker is employed on a public work for the purposes of this section if the worker is employed by a contractor or subcontractor in the execution of a contract for the public work with the state, a political subdivision of the state, or any officer or public body of the state or a political subdivision of the state.

Added by Acts 1995, 74th Leg., ch. 76, Sec. 5.49(a), eff. Sept. 1, 1995. Amended by Acts 1997, 75th Leg., ch. 165, Sec. 18.01, eff. Sept. 1, 1997.

#### §Sec. 2258.022. DETERMINATION OF PREVAILING WAGE RATES.

(a) For a contract for a public work awarded by a political subdivision of the state, the public body shall determine the general prevailing rate of per diem wages in the locality in which the public work is to be performed for each craft or type of worker needed to execute the contract and the prevailing rate for legal holiday and overtime work by:

(1) conducting a survey of the wages received by classes of workers employed on projects of a character similar to the contract work in the political subdivision of the state in which the public work is to be performed; or

(2) using the prevailing wage rate as determined by the United States Department of Labor in accordance with the Davis-Bacon Act (40 U.S.C. Section 276a et seq.), and its subsequent amendments.

(b) This subsection applies only to a public work located in a county bordering the United Mexican States or in a county adjacent to a county bordering the United Mexican States. For a contract for a public work awarded by the state, the public body shall determine the general prevailing rate of per diem wages in the locality in which the public work is to be performed for each craft or type of worker needed to execute the contract and the prevailing rate for legal holiday and overtime work as follows. The public body shall conduct a survey of the wages received by classes of workers employed on projects of a character similar to the contract work both statewide and in the political subdivision of the state in which the public work is to be performed. The public body shall also consider the prevailing wage rate as determined by the United States Department of Labor in accordance with the Davis-Bacon Act (40 U.S.C. Section 276a et seq.), and its subsequent amendments, but only if the survey used to determine that rate was conducted within a three-year period preceding the date the public body calls for bids for the public work. The public body shall determine the general prevailing rate of per diem wages in the locality based on the higher of:

(1) the rate determined from the survey conducted in the political subdivision;

(2) the arithmetic mean between the rate determined from the survey conducted in the political subdivision and the rate determined from the statewide survey; and

(3) if applicable, the arithmetic mean between the rate determined from the survey conducted in the political subdivision and the rate determined by the United States Department of Labor.

(c) The public body shall determine the general prevailing rate of per diem wages as a sum certain, expressed in dollars and cents.

(d) A public body shall specify in the call for bids for the contract and in the contract itself the wage rates determined under this section.

(e) The public body's determination of the general prevailing rate of per diem wages is final.

Added by Acts 1995, 74th Leg., ch. 76, Sec. 5.49(a), eff. Sept. 1, 1995. Amended by Acts 1997, 75th Leg., ch. 165, Sec. 18.02, eff. Sept. 1, 1997; Acts 2001, 77th Leg., ch. 1422, Sec. 14.05, eff. Sept. 1, 2001.

Amended by: Acts 2007, 80th Leg., R.S., Ch. 728, Sec. 1, eff. September 1, 2007.

**§Sec. 2258.023. PREVAILING WAGE RATES TO BE PAID BY CONTRACTOR AND SUBCONTRACTOR; PENALTY.**

(a) The contractor who is awarded a contract by a public body or a subcontractor of the contractor shall pay not less than the rates determined under Section 2258.022 to a worker employed by it in the execution of the contract.

(b) A contractor or subcontractor who violates this section shall pay to the state or a political subdivision of the state on whose behalf the contract is made, \$60 for each worker employed for each calendar day or part of the day that the worker is paid less than the wage rates stipulated in the contract. A public body awarding a contract shall specify this penalty in the contract.

(c) A contractor or subcontractor does not violate this section if a public body awarding a contract does not determine the prevailing wage rates and specify the rates in the contract as provided by Section 2258.022.

(d) The public body shall use any money collected under this section to offset the costs incurred in the administration of this chapter.

(e) A municipality is entitled to collect a penalty under this section only if the municipality has a population of more than 10,000.

Added by Acts 1995, 74th Leg., ch. 76, Sec. 5.49(a), eff. Sept. 1, 1995.

**§Sec. 2258.024. RECORDS.**

(a) A contractor and subcontractor shall keep a record showing:

- (1) the name and occupation of each worker employed by the contractor or subcontractor in the construction of the public work; and
- (2) the actual per diem wages paid to each worker.

(b) The record shall be open at all reasonable hours to inspection by the officers and agents of the public body.

Added by Acts 1995, 74th Leg., ch. 76, Sec. 5.49(a), eff. Sept. 1, 1995.

**§Sec. 2258.025. PAYMENT GREATER THAN PREVAILING RATE NOT PROHIBITED.** This chapter does not prohibit the payment to a worker employed on a public work an amount greater than the general prevailing rate of per diem wages.

Added by Acts 1995, 74th Leg., ch. 76, Sec. 5.49(a), eff. Sept. 1, 1995.

§Sec. 2258.026. RELIANCE ON CERTIFICATE OF SUBCONTRACTOR. A contractor is entitled to rely on a certificate by a subcontractor regarding the payment of all sums due those working for the subcontractor until the contrary has been determined.

Added by Acts 1995, 74th Leg., ch. 76, Sec. 5.49(a), eff. Sept. 1, 1995.

#### SUBCHAPTER C. ENFORCEMENT; CIVIL AND CRIMINAL PENALTIES

§Sec. 2258.051. DUTY OF PUBLIC BODY TO HEAR COMPLAINTS AND WITHHOLD PAYMENT. A public body awarding a contract, and an agent or officer of the public body, shall:

(1) take cognizance of complaints of all violations of this chapter committed in the execution of the contract; and

(2) withhold money forfeited or required to be withheld under this chapter from the payments to the contractor under the contract, except that the public body may not withhold money from other than the final payment without a determination by the public body that there is good cause to believe that the contractor has violated this chapter.

Added by Acts 1995, 74th Leg., ch. 76, Sec. 5.49(a), eff. Sept. 1, 1995.

§Sec. 2258.052. COMPLAINT; INITIAL DETERMINATION.

(a) On receipt of information, including a complaint by a worker, concerning an alleged violation of Section 2258.023 by a contractor or subcontractor, a public body shall make an initial determination as to whether good cause exists to believe that the violation occurred.

(b) A public body must make its determination under Subsection (a) before the 31st day after the date the public body receives the information.

(c) A public body shall notify in writing the contractor or subcontractor and any affected worker of its initial determination.

(d) A public body shall retain any amount due under the contract pending a final determination of the violation.

Added by Acts 1995, 74th Leg., ch. 76, Sec. 5.49(a), eff. Sept. 1, 1995.

§Sec. 2258.053. ARBITRATION REQUIRED FOR UNRESOLVED ISSUE.

(a) An issue relating to an alleged violation of Section 2258.023, including a penalty owed to a public body or an affected worker, shall be submitted to binding arbitration in accordance with the Texas General Arbitration Act (Article 224 et seq., Revised Statutes) if the contractor or subcontractor and any affected worker do not resolve the issue by agreement before the 15th day after the date the public body makes its initial determination under Section 2258.052.

(b) If the persons required to arbitrate under this section do not agree on an arbitrator before the 11th day after the date that arbitration is required under Subsection (a), a district court shall appoint an arbitrator on the petition of any of the persons.

(c) A public body is not a party in the arbitration.

Added by Acts 1995, 74th Leg., ch. 76, Sec. 5.49(a), eff. Sept. 1, 1995.

§Sec. 2258.054. ARBITRATION AWARD; COSTS. (a) If an arbitrator determines that Section 2258.023 has been violated, the arbitrator shall assess and award against the contractor or subcontractor:

- (1) penalties as provided by Section 2258.023 and this section; and
- (2) all amounts owed to the affected worker.

(b) An arbitrator shall assess and award all reasonable costs, including the arbitrator's fee, against the party who does not prevail. Costs may be assessed against the worker only if the arbitrator finds that the claim is frivolous. If the arbitrator does not find that the claim is frivolous and does not make an award to the worker, costs are shared equally by the parties.

Added by Acts 1995, 74th Leg., ch. 76, Sec. 5.49(a), eff. Sept. 1, 1995.

§Sec. 2258.055. ARBITRATION DECISION AND AWARD FINAL. The decision and award of the arbitrator is final and binding on all parties and may be enforced in any court of competent jurisdiction.

Added by Acts 1995, 74th Leg., ch. 76, Sec. 5.49(a), eff. Sept. 1, 1995.

§Sec. 2258.056. PAYMENT BY PUBLIC BODY TO WORKER; ACTION TO RECOVER PAYMENT.

(a) A public body shall use any amounts retained under this chapter to pay the worker the difference between the amount the worker received in wages for labor on the public work at the rate paid by the contractor or subcontractor and the amount the worker would have received at the general prevailing wage rate as provided in the arbitrator's award.

(b) The public body may adopt rules, orders, or ordinances relating to the manner in which a reimbursement is made.

(c) If the amounts retained by a public body under this chapter are not sufficient for the public body to pay the worker the full amount owed, the worker has a right of action against the contractor or subcontractor and the surety of the contractor or subcontractor to recover the amount owed, reasonable attorney's fees, and court costs.

Added by Acts 1995, 74th Leg., ch. 76, Sec. 5.49(a), eff. Sept. 1, 1995.

§Sec. 2258.057. WITHHOLDING BY CONTRACTOR.

(a) A contractor may withhold from a subcontractor sufficient money to cover an amount withheld from the contractor by a public body because the subcontractor violated this chapter.

(b) If the contractor has made a payment to the subcontractor, the contractor may withhold money from any future payments owed to the subcontractor or sue the subcontractor or the subcontractor's surety for the amount withheld from the contractor by a public body because of the subcontractor's violation.

Added by Acts 1995, 74th Leg., ch. 76, Sec. 5.49(a), eff. Sept. 1, 1995.

§Sec. 2258.058. CRIMINAL OFFENSE.

(a) An officer, agent, or representative of the state or of a political subdivision of the state commits an offense if the person wilfully violates or does not comply with a provision of this chapter.

(b) A contractor or subcontractor of a public work under this chapter, or an agent or representative of the contractor or subcontractor, commits an offense if the person violates Section 2258.024.

(c) An offense under this section is punishable by:

- (1) a fine not to exceed \$500;
- (2) confinement in jail for a term not to exceed six months; or
- (3) both a fine and confinement.

Added by Acts 1995, 74th Leg., ch. 76, Sec. 5.49(a), eff. Sept. 1, 1995.

General Decision Number: TX170008 01/06/2017 TX8

Superseded General Decision Number: TX20160008

State: Texas

Construction Types: Heavy and Highway

Counties: Cameron, Hidalgo and Webb Counties in Texas.

HEAVY & HIGHWAY CONSTRUCTION PROJECTS

Note: Under Executive Order (EO) 13658, an hourly minimum wage of \$10.20 for calendar year 2017 applies to all contracts subject to the Davis-Bacon Act for which the contract is awarded (and any solicitation was issued) on or after January 1, 2015. If this contract is covered by the EO, the contractor must pay all workers in any classification listed on this wage determination at least \$10.20 per hour (or the applicable wage rate listed on this wage determination, if it is higher) for all hours spent performing on the contract in calendar year 2017. The EO minimum wage rate will be adjusted annually. Additional information on contractor requirements and worker protections under the EO is available at [www.dol.gov/whd/govcontracts](http://www.dol.gov/whd/govcontracts).

Modification Number	Publication Date
0	01/06/2017

\* SUTX2011-003 08/02/2011

	Rates	Fringes
CEMENT MASON/CONCRETE FINISHER (Paving & Structures)...	\$ 12.46	
FORM BUILDER/FORM SETTER (Structures).....	\$ 12.30	
FORM SETTER (Paving & Curb).....	\$ 12.16	
LABORER		
Asphalt Raker.....	\$ 10.61	
Flagger.....	\$ 9.10	
Laborer, Common.....	\$ 9.86	
Laborer, Utility.....	\$ 11.53	
Pipelayer.....	\$ 11.87	
Work Zone Barricade Servicer.....	\$ 12.88	
POWER EQUIPMENT OPERATOR:		
Asphalt Distributor.....	\$ 13.48	
Asphalt Paving Machine.....	\$ 12.25	
Broom or Sweeper.....	\$ 10.33	
Crane, Lattice Boom 80 Tons or Less.....	\$ 14.39	
Crawler Tractor.....	\$ 16.63	
Excavator, 50,000 lbs or		

less.....	\$ 12.56
Excavator, over 50,000 lbs..	\$ 15.23
Foundation Drill, Truck Mounted.....	\$ 16.86
Front End Loader Operator, Over 3 CY.....	\$ 13.69
Front End Loader, 3 CY or less.....	\$ 13.49
Loader/Backhoe.....	\$ 12.77
Mechanic.....	\$ 15.47
Milling Machine.....	\$ 14.64
Motor Grader Operator, Rough.....	\$ 14.62
Motor Grader, Fine Grade....	\$ 16.52
Scraper.....	\$ 11.07
 Servicer.....	\$ 12.34
 Steel Worker (Reinforcing).....	\$ 14.07
 TRUCK DRIVER	
Lowboy-Float.....	\$ 13.63
Single Axle.....	\$ 10.82
Single or Tandem Axle Dump..	\$ 14.53
Tandem Axle Tractor with Semi Trailer.....	\$ 12.12
 WELDER.....	\$ 14.02

-----

WELDERS - Receive rate prescribed for craft performing operation to which welding is incidental.

=====

Note: Executive Order (EO) 13706, Establishing Paid Sick Leave for Federal Contractors applies to all contracts subject to the Davis-Bacon Act for which the contract is awarded (and any solicitation was issued) on or after January 1, 2017. If this contract is covered by the EO, the contractor must provide employees with 1 hour of paid sick leave for every 30 hours they work, up to 56 hours of paid sick leave each year. Employees must be permitted to use paid sick leave for their own illness, injury or other health-related needs, including preventive care; to assist a family member (or person who is like family to the employee) who is ill, injured, or has other health-related needs, including preventive care; or for reasons resulting from, or to assist a family member (or person who is like family to the employee) who is a victim of, domestic violence, sexual assault, or stalking. Additional information on contractor requirements and worker protections under the EO is available at [www.dol.gov/whd/govcontracts](http://www.dol.gov/whd/govcontracts).

Unlisted classifications needed for work not included within the scope of the classifications listed may be added after award only as provided in the labor standards contract clauses (29CFR 5.5 (a) (1) (ii)).

-----

The body of each wage determination lists the classification and wage rates that have been found to be prevailing for the cited type(s) of construction in the area covered by the wage determination. The classifications are listed in alphabetical order of "identifiers" that indicate whether the particular rate is a union rate (current union negotiated rate for local), a survey rate (weighted average rate) or a union average rate (weighted union average rate).

#### Union Rate Identifiers

A four letter classification abbreviation identifier enclosed in dotted lines beginning with characters other than "SU" or "UAVG" denotes that the union classification and rate were prevailing for that classification in the survey. Example: PLUM0198-005 07/01/2014. PLUM is an abbreviation identifier of the union which prevailed in the survey for this classification, which in this example would be Plumbers. 0198 indicates the local union number or district council number where applicable, i.e., Plumbers Local 0198. The next number, 005 in the example, is an internal number used in processing the wage determination. 07/01/2014 is the effective date of the most current negotiated rate, which in this example is July 1, 2014.

Union prevailing wage rates are updated to reflect all rate changes in the collective bargaining agreement (CBA) governing this classification and rate.

#### Survey Rate Identifiers

Classifications listed under the "SU" identifier indicate that no one rate prevailed for this classification in the survey and the published rate is derived by computing a weighted average rate based on all the rates reported in the survey for that classification. As this weighted average rate includes all rates reported in the survey, it may include both union and non-union rates. Example: SULA2012-007 5/13/2014. SU indicates the rates are survey rates based on a weighted average calculation of rates and are not majority rates. LA indicates the State of Louisiana. 2012 is the year of survey on which these classifications and rates are based. The next number, 007 in the example, is an internal number used in producing the wage determination. 5/13/2014 indicates the survey completion date for the classifications and rates under that identifier.

Survey wage rates are not updated and remain in effect until a new survey is conducted.

#### Union Average Rate Identifiers

Classification(s) listed under the UAVG identifier indicate that no single majority rate prevailed for those classifications; however, 100% of the data reported for the classifications was union data. EXAMPLE: UAVG-OH-0010 08/29/2014. UAVG indicates that the rate is a weighted union average rate. OH indicates the state. The next number, 0010 in the example, is an internal number used in producing the wage

determination. 08/29/2014 indicates the survey completion date for the classifications and rates under that identifier.

A UAVG rate will be updated once a year, usually in January of each year, to reflect a weighted average of the current negotiated/CBA rate of the union locals from which the rate is based.

---

WAGE DETERMINATION APPEALS PROCESS

1.) Has there been an initial decision in the matter? This can be:

- \* an existing published wage determination
- \* a survey underlying a wage determination
- \* a Wage and Hour Division letter setting forth a position on a wage determination matter
- \* a conformance (additional classification and rate) ruling

On survey related matters, initial contact, including requests for summaries of surveys, should be with the Wage and Hour Regional Office for the area in which the survey was conducted because those Regional Offices have responsibility for the Davis-Bacon survey program. If the response from this initial contact is not satisfactory, then the process described in 2.) and 3.) should be followed.

With regard to any other matter not yet ripe for the formal process described here, initial contact should be with the Branch of Construction Wage Determinations. Write to:

Branch of Construction Wage Determinations  
Wage and Hour Division  
U.S. Department of Labor  
200 Constitution Avenue, N.W.  
Washington, DC 20210

2.) If the answer to the question in 1.) is yes, then an interested party (those affected by the action) can request review and reconsideration from the Wage and Hour Administrator (See 29 CFR Part 1.8 and 29 CFR Part 7). Write to:

Wage and Hour Administrator  
U.S. Department of Labor  
200 Constitution Avenue, N.W.  
Washington, DC 20210

The request should be accompanied by a full statement of the interested party's position and by any information (wage payment data, project description, area practice material, etc.) that the requestor considers relevant to the issue.

3.) If the decision of the Administrator is not favorable, an interested party may appeal directly to the Administrative Review Board (formerly the Wage Appeals Board). Write to:

Administrative Review Board  
U.S. Department of Labor  
200 Constitution Avenue, N.W.  
Washington, DC 20210

4.) All decisions by the Administrative Review Board are final.

=====  
END OF GENERAL DECISION



U.S. Department of Housing  
and Urban Development

Labor Relations Desk Guide  
LR01.DG

# DAVIS-BACON

## LABOR STANDARDS

*A Contractor's Guide  
to Prevailing Wage Requirements  
for Federally-Assisted Construction Projects*



*January 2012  
Previous versions obsolete*



---

## INTRODUCTION

This Guide has been prepared for you as a contractor performing work on construction projects that are assisted by the Department of Housing and Urban Development and subject to Davis-Bacon prevailing wage requirements. This Guide does not address contractor requirements involved in direct Federal contracting where HUD or another Federal agency enters into a procurement contract. In this latter case, the Federal Acquisition Regulations (FAR) are applicable. While the guidance contained in this Guide is generally applicable to any Davis-Bacon covered project, specific questions pertaining to direct Federal contracts should be addressed to the Contracting Officer who signed the contract for the Federal agency.

Our objective here is to provide you with a guide which is simple and non-bureaucratic yet comprehensive and which will help you better understand and comply with Davis-Bacon labor standards. HUD's Office of Labor Relations worked closely with the Department of Labor's Wage and Hour Division to make sure that the labor standards provisions in your contract and the specifics of complying with them represent the latest information. It is the Department of Labor which has general administrative oversight of all Federal contracting agencies, such as HUD, which administer the day-to-day responsibilities of enforcing Davis-Bacon provisions in construction contracts they either fund or assist in funding.

There are three chapters in this Guide. The first chapter offers a brief description of the laws and regulations associated with Federal labor standards administration and enforcement and discusses both what's in your contract that requires Davis-Bacon compliance and your responsibilities. The second chapter deals with labor standards and payroll reporting requirements. The third chapter discusses what can happen in the event there is a dispute about the wage rates that should be (or have been) paid and any back wages that may be due.

Finally, not all HUD construction projects are covered by Davis-Bacon wage rates. For the purpose of this Guide, we are assuming that a determination has already been made that Davis-Bacon wage rates are applicable. Should you wish assistance in determining whether Davis-Bacon wage rates apply to a particular project or if you need other related technical assistance, please consult with the HUD Labor Relations Field staff for your area. If you don't know which staff to contact, a list of Labor Relations field offices and their geographic areas and telephone numbers can be found on HUD's Home Page at the address below.

**Visit the Office of Labor Relations on-line:**

**<http://www.hud.gov/offices/olr>**

Obtain additional copies of this Guide and other publications at our website or by telephone from HUD's Customer Service Center at (800)767-7468.



---

## TABLE OF CONTENTS

INTRODUCTION .....	i
<b>CHAPTER 1        LAWS, REGULATIONS, CONTRACTS                          AND RESPONSIBILITIES .....</b>	<b>1-1</b>
<b>1-1    DAVIS-BACON AND OTHER LABOR LAWS .....</b>	<b>1-1</b>
a. The Davis-Bacon Act (DBA) .....	1-1
b. The Contract Work Hours and Safety Standards Act (CWHSSA) .....	1-1
c. The Copeland Act (Anti-Kickback Act) .....	1-2
d. The Fair Labor Standards Act (FLSA) .....	1-2
<b>1-2    DAVIS-BACON REGULATIONS .....</b>	<b>1-2</b>
<b>1-3    CONSTRUCTION CONTRACT PROVISIONS .....</b>	<b>1-2</b>
<b>1-4    RESPONSIBILITY OF THE PRINCIPAL CONTRACTOR .....</b>	<b>1-3</b>
<b>1-5    RESPONSIBILITY OF THE CONTRACT ADMINISTRATOR .....</b>	<b>1-4</b>
 <b>CHAPTER 2        HOW TO COMPLY WITH LABOR STANDARDS                          AND PAYROLL REPORTING REQUIREMENTS .....</b>	 <b>2-1</b>
<b>SECTION - I THE BASICS</b>	
<b>2-1    THE WAGE DECISION .....</b>	<b>2-1</b>
a. The work classifications and wage rates .....	2-1
b. Posting the wage decision .....	2-2
<b>2-2    ADDITIONAL "TRADE" CLASSIFICATIONS AND WAGE RATES .....</b>	<b>2-2</b>
a. Additional classification rules .....	2-2
b. Making the request .....	2-3
c. HUD review .....	2-3
d. DOL decision .....	2-3
<b>2-3    CERTIFIED PAYROLL REPORTS .....</b>	<b>2-4</b>
a. Payroll formats .....	2-4
b. Payroll certifications .....	2-4
c. "No work" payrolls .....	2-4
d. Payroll review and submission .....	2-5
e. Payroll retention .....	2-5
f. Payroll inspection .....	2-5
<b>2-4    DAVIS-BACON DEFINITIONS .....</b>	<b>2-5</b>
a. Laborer or mechanic .....	2-5
b. Employee .....	2-6
c. Apprentices and trainees .....	2-6
d. Prevailing wages or wage rates .....	2-7
e. Fringe benefits .....	2-7
f. Overtime .....	2-7
g. Deductions .....	2-8
h. Proper designation of trade .....	2-8
i. Site of work .....	2-8

---

## SECTION - II REPORTING REQUIREMENT

<b>2-5</b>	<b>COMPLETING A PAYROLL REPORT</b> .....	2-9
	a. Project and contractor/subcontractor information.....	2-9
	b. Employee information.....	2-9
	c. Work classification.....	2-9
	d. Hours worked .....	2-10
	e. Rate of pay .....	2-10
	f. Gross wages earned .....	2-10
	g. Deductions .....	2-11
	h. Net pay.....	2-11
	i. Statement of compliance.....	2-11
	j. Signature.....	2-11

## SECTION III - PAYROLL REVIEWS AND CORRECTIONS

<b>2-6</b>	<b>COMPLIANCE REVIEWS</b> .....	2-12
	a. On-site interviews.....	2-12
	b. Project payroll reviews .....	2-12
<b>2-7</b>	<b>TYPICAL PAYROLL ERRORS AND REQUIRED CORRECTIONS</b> .....	2-12
	a. Inadequate payroll information .....	2-12
	b. Missing identification numbers .....	2-12
	c. Incomplete payrolls .....	2-13
	d. Classifications .....	2-13
	e. Wage Rates.....	2-13
	f. Apprentices and trainees.....	2-13
	g. Overtime.....	2-13
	h. Computations .....	2-13
	i. Deductions .....	2-13
	j. Fringe benefits.....	2-14
	k. Signature .....	2-14
	l. On-site interview comparisons .....	2-14
	m. Correction certified payroll.....	2-14
<b>2-8</b>	<b>RESTITUTION FOR UNDERPAYMENT OF WAGES</b> .....	2-14
	a. Notification.....	2-14
	b. Computing wage restitution.....	2-15
	c. Correction certified payrolls.....	2-15
	d. Review of correction CPR .....	2-15
	e. Unfound workers .....	2-15

---

<b>CHAPTER 3</b>	<b>LABOR STANDARDS DISPUTES, ADMINISTRATIVE REVIEWS, WITHHOLDING, DEPOSITS AND ESCROW ACCOUNTS, AND SANCTIONS .....</b>	<b>3-1</b>
<b>3-1</b>	<b>INTRODUCTION .....</b>	<b>3-1</b>
<b>3-2</b>	<b>ADMINISTRATIVE REVIEW ON LABOR STANDARDS DISPUTES .....</b>	<b>3-1</b>
	a. Additional classifications and wage rates .....	3-1
	b. Findings of underpayment .....	3-2
<b>3-3</b>	<b>WITHHOLDING .....</b>	<b>3-2</b>
<b>3-4</b>	<b>DEPOSITS AND ESCROWS .....</b>	<b>3-3</b>
<b>3-5</b>	<b>ADMINISTRATIVE SANCTIONS .....</b>	<b>3-4</b>
	a. DOL debarment .....	3-4
	b. HUD sanctions .....	3-4
<b>3-6</b>	<b>FALSIFICATION OF CERTIFIED PAYROLL REPORTS .....</b>	<b>3-5</b>

**APPENDICIES**

<b>ACRONYMS AND SYMBOLS .....</b>	<b>A-1</b>
<b>DAVIS-BACON - RELATED WEB SITES* .....</b>	<b>A-2</b>
<b>HUD-4720, Project Wage Rate Sheet .....</b>	<b>A-3</b>
<b>WH-347, Payroll Form/Statement of Compliance .....</b>	<b>A-4</b>

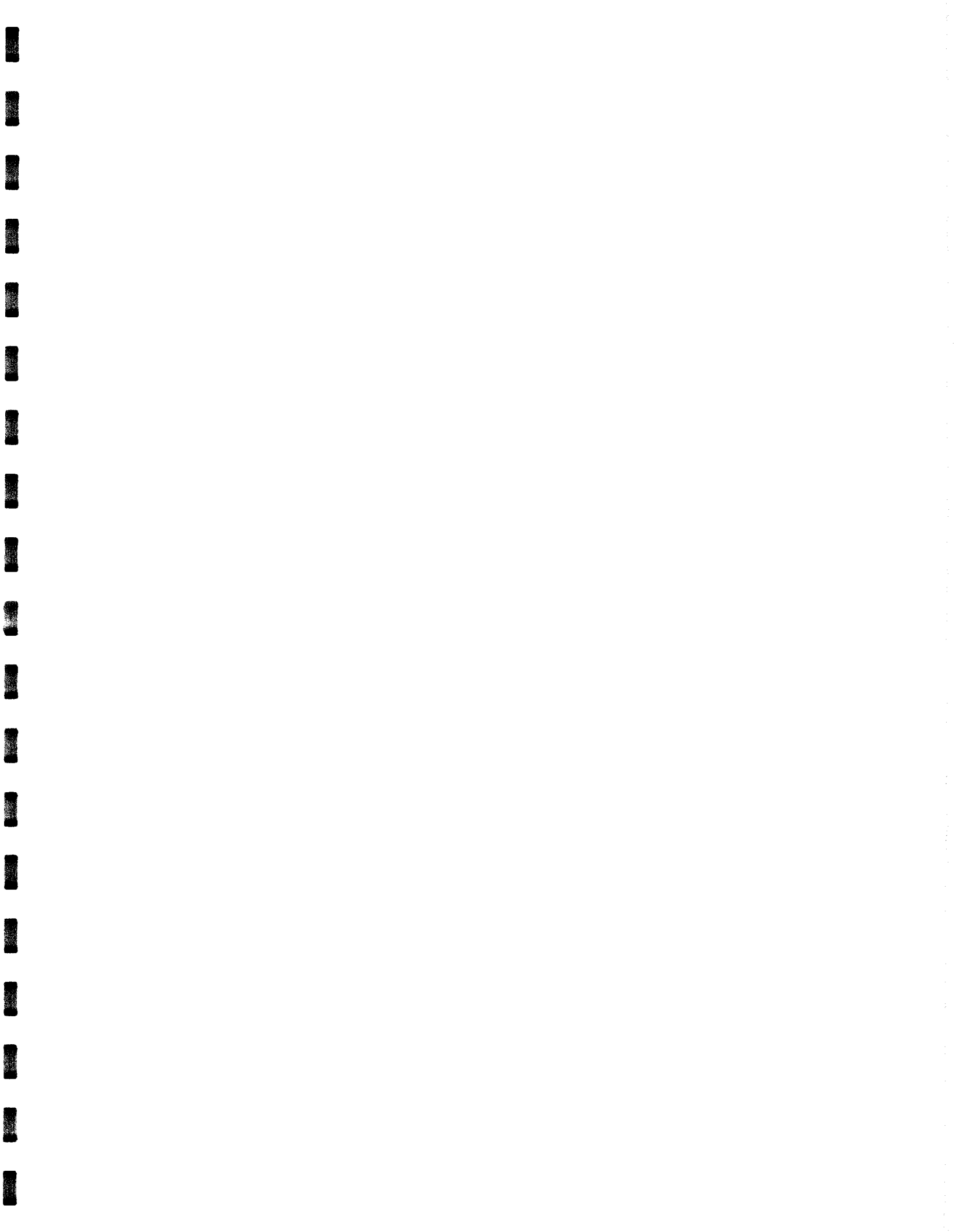

---

## CHAPTER 1      LAWS, REGULATIONS, CONTRACTS AND RESPONSIBILITIES

The following paragraphs describe what the labor standards laws and regulations actually say and what they mean to you on HUD projects:

### 1-1      DAVIS-BACON AND OTHER LABOR LAWS.

- a. **The Davis-Bacon Act (DBA).** The Davis-Bacon Act requires the payment of prevailing wage rates (which are determined by the U.S. Department of Labor) to all laborers and mechanics on Federal government and District of Columbia construction projects in excess of \$2,000. Construction includes alteration and/or repair, including painting and decorating, of public buildings or public works.

Most HUD construction work is not covered by the DBA itself since HUD seldom contracts directly for construction services. Most often, if Davis-Bacon wage rates apply to a HUD project it is because of a labor provision contained in one of HUD's "Related Acts" such as the U. S. Housing Act of 1937, the National Housing Act, the Housing and Community Development Act of 1974, the National Affordable Housing Act of 1990, and the Native American Housing Assistance and Self-Determination Act of 1996. The Related Acts are often referred to as the Davis-Bacon and Related Acts or DBRA.

- b. **The Contract Work Hours and Safety Standards Act (CWHSSA).** CWHSSA requires time and one-half pay for overtime (O/T) hours (over 40 in any workweek) worked on the covered project. The CWHSSA applies to both direct Federal contracts and to indirect Federally-assisted contracts **except** where the assistance is solely in the nature of a loan guarantee or insurance. CWHSSA violations carry a liquidated damages penalty (\$10/day per violation). Intentional violations of CWHSSA standards can be considered for Federal criminal prosecution.

CWHSSA does not apply to prime contracts of \$100,000 or less. In addition, some HUD projects are not covered by CWHSSA because some HUD programs only provide loan guarantees or insurance. CWHSSA also does not apply to construction or rehabilitation contracts that are not subject to Federal prevailing wage rates (e.g., Davis-Bacon wage rates, or HUD-determined rates for operation of public housing and Indian block grant-assisted housing). However, even though CWHSSA overtime pay is not required, Fair Labor Standards Act (FLSA) overtime pay is probably still applicable. (See also Labor Relations Letter SL-95-01, CWHSSA Coverage threshold for overtime and health and safety provision, available on-line at the HUD Labor Relations Library at: [www.hud.gov/offices/olr/library.cfm](http://www.hud.gov/offices/olr/library.cfm))

- 
- c. **The Copeland Act (Anti-Kickback Act).** The Copeland Act makes it a Federal crime for anyone to require any laborer or mechanic (employed on a Federal or Federally-assisted project) to kickback (i.e., give up or pay back) any part of their wages. The Copeland Act requires every employer (contractors and subcontractors) to submit weekly certified payroll reports (CPRs) and regulates permissible payroll deductions.
  - d. **The Fair Labor Standards Act (FLSA).** The FLSA contains Federal minimum wage rates, overtime (O/T), and child labor requirements. These requirements generally apply to any labor performed. The DOL has the authority to administer and enforce FLSA. HUD will refer to the DOL any possible FLSA violations that are found on HUD projects.

## 1-2 **DAVIS-BACON REGULATIONS.**

The Department of Labor (DOL) has published rules and instructions concerning Davis-Bacon and other labor laws in the Code of Federal Regulations (CFR). These regulations can be found in ***Title 29 CFR Parts 1, 3, 5, 6 and 7.*** Part 1 explains how the DOL establishes and publishes DBA wage determinations (aka wage decisions) and provides instructions on how to use the determinations. Part 3 describes Copeland Act requirements for payroll deductions and the submission of weekly certified payroll reports. Part 5 covers the labor standards provisions that are in your contract relating to Davis-Bacon Act wage rates and the responsibilities of contractors and contracting agencies to administer and enforce the provisions. Part 6 provides for administrative proceedings enforcing Federal labor standards on construction and service contracts. Last, Part 7 sets parameters for practice before the Administrative Review Board. These regulations are used as the basis for administering and enforcing the laws.

DOL Regulations are available on-line on the World Wide Web:  
[http://www.dol.gov/dol/allcfr/Title\\_29.htm](http://www.dol.gov/dol/allcfr/Title_29.htm)

## 1-3 **CONSTRUCTION CONTRACT PROVISIONS**

Each contract subject to Davis-Bacon labor standards requirements must contain labor standards clauses and a Davis-Bacon wage decision. These documents are normally bound into the contract specifications.

- a. The labor standards clauses. The labor standards clauses describe the responsibilities of the contractor concerning Davis-Bacon wages and obligate the contractor to comply with the labor requirements. The labor standards clauses also provide for remedies in the event of violations, including withholding from payments due to the contractor to ensure the payment of wages or liquidated damages which may be found due. These contract clauses enable the contract administrator to enforce the Federal labor standards applicable to the project. HUD has standard forms that contain contract clauses. For example, the HUD-2554, Supplementary Conditions to the Contract for Construction, which is issued primarily for FHA multifamily housing and other construction projects

---

administered by HUD; the HUD-4010, Federal Labor Standards Provisions, which is used for CDBG and HOME projects, and the HUD-5370, General Conditions of the Contract for Construction or the HUD-5370-EZ (construction contracts ≤\$100,000) which are used for Public and Indian Housing projects.

HUD program labor standards forms are available on-line at:  
[www.hud.gov/offices/adm/hudclips/index.cfm](http://www.hud.gov/offices/adm/hudclips/index.cfm)

- b. Davis-Bacon Wage Decisions. The Davis-Bacon wage decision (or wage determination) is a listing of various construction work classifications, such as Carpenter, Electrician, Plumber and Laborer, and the minimum wage rates (and fringe benefits, where prevailing) that people performing work in those classifications must be paid.

Davis-Bacon wage decisions are established by the DOL for various types of construction (e.g., residential, heavy, highway) and apply to specific geographic areas, usually a county or group of counties. Wage decisions are modified from time to time to keep them current. In most cases, when the contract is awarded or when construction begins, the wage decision is “locked-in” and no future modifications are applicable to the contract or project involved.

All current Davis-Bacon wage decisions can be accessed on-line at no cost at:  
<http://www.wdol.gov>

#### 1-4 RESPONSIBILITY OF THE PRINCIPAL CONTRACTOR

The principal contractor (also referred to as the *prime or general contractor*) is responsible for the full compliance of all employers (the contractor, subcontractors and any lower-tier subcontractors) with the labor standards provisions applicable to the project. Because of the contractual relationship between a prime contractor and his/her subcontractors, subcontractors generally should communicate with the contract administrator only through the prime contractor. (See Contract Administrator, below.)

To make this Guide easier to understand, the term “prime contractor” will mean the principal contractor; “subcontractor” will mean all subcontractors including lower-tier subcontractors; and the term “employer” will mean all contractors as a group, including the prime contractor and any subcontractors and lower-tier subcontractors.

---

## 1-5 RESPONSIBILITY OF THE CONTRACT ADMINISTRATOR.

The *contract administrator* is responsible for the proper administration and enforcement of the Federal labor standards provisions on contracts covered by Davis-Bacon requirements. We use this term to represent the person (or persons) who will provide labor standards advice and support to you and other project principals (e.g., the owner, sponsor, architect), including providing the proper Davis-Bacon wage decision (see 2-1, *The Wage Decision*) and ensuring that the wage decision and contract clauses are incorporated into the contract for construction. The contract administrator also monitors labor standards compliance (see 2-6, *Compliance Reviews*) by conducting interviews with construction workers at the job site and reviewing payroll reports, and oversees any enforcement actions that may be required.

The contract administrator could be an employee or agent of HUD, or of a city or county or public housing agency. For HUD projects administered directly by HUD staff, usually FHA-insured multifamily projects, the contract administrator will be the HUD Labor Relations field staff. But many HUD-assisted projects are administered by local contracting agencies such as Public Housing Agencies (PHAs), Indian tribes and tribally-designated housing entities (TDHEs), and States, cities and counties under HUD's Community Development Block Grant (CDBG) and HOME programs. In these cases, the contract administrator will likely be local agency staff. In either case, the guidance for you remains essentially the same.

The DOL also has a role in monitoring Davis-Bacon administration and enforcement. In addition, DOL has independent authority to conduct investigations. A DOL investigator or other DOL representative may visit Davis-Bacon construction sites to interview construction workers or review payroll information.

---

## CHAPTER 2      HOW TO COMPLY WITH LABOR STANDARDS AND PAYROLL REPORTING REQUIREMENTS

**WHERE TO START?**      Now that you know you're on a Davis-Bacon project and you know some of the legal and practical implications, what's next?

### SECTION I - THE BASICS

#### 2-1      **THE WAGE DECISION.**

Davis-Bacon labor standards stipulate the wage payment requirements for Carpenters, Electricians, Plumbers, Roofers, Laborers, and other construction work classifications that may be needed for the project. The Davis-Bacon wage decision that applies to the project contains a schedule of work classifications and wage rates that must be followed. If you don't have it already (and by now you should), you'll want to get a copy of the applicable Davis-Bacon wage decision.

Remember, the wage decision is contained in the contract specifications along with the labor standards clauses. See 1-3, Construction Contract Provisions.

- a. **The work classifications and wage rates.** A Davis-Bacon wage decision is simply a listing of different work classifications and the minimum wage rates that must be paid to anyone performing work in those classifications. You'll want to make sure that the work classification(s) you need are contained in the wage decision and make certain you know exactly what wage rate(s) you will need to pay. Some wage decisions cover several counties and/or types of construction work (for example, residential and commercial work) and can be lengthy and difficult to read. Contact the contract administrator (HUD Labor Relations field staff or local agency staff) if you have any trouble reading the wage decision or finding the work classification(s) you need.

To make reading lengthy wage decisions easier for you, the contract administrator may prepare a Project Wage Rate Sheet (HUD-4720). This Sheet is a one-page transcript that will show only the classifications and wage rates for a particular project. A blank copy of a Project Wage Rate Sheet is provided for you in the appendix. Also, a fillable version of this form is available on-line at HUDClips (see web address in the Appendix). Contact the contract administrator monitoring your project for assistance with a Project Wage Rate Sheet.

- 
- b. **Posting the wage decision.** If you are the prime contractor, you will be responsible for posting a copy of the wage decision (or the Project Wage Rate Sheet) and a copy of the DOL Davis-Bacon poster titled Employee Rights under the Davis-Bacon Act (Form WH-1321) at the job site in a place that is easily accessible to all of the construction workers employed at the project and where the wage decision and poster won't be destroyed by wind or rain, etc. The Employee Rights under the Davis-Bacon Act poster is available in English and Spanish on-line at HUDClips (see address in the Appendix).

The Employee Rights under the Davis-Bacon Act poster (WH-1321) replaces the Notice to all Employees. The new poster is available in English and Spanish on-line at HUDClips (see address in the Appendix).

## 2-2 **ADDITIONAL "TRADE" CLASSIFICATIONS AND WAGE RATES.**

What if the work classification you need isn't on the wage decision? If the work classification(s) that you need doesn't appear on the wage decision, you will need to request an additional classification and wage rate. This process is usually very simple and you'll want to start the request right away. Basically, you identify the classification you need and recommend a wage rate for DOL to approve for the project. There are a few rules about additional classifications; you'll find these rules in the DOL regulations, Part 5, and in the labor clauses in your contract. The rules are summarized for you here:

- a. **Additional classification rules.** Additional classifications and wage rates can be approved if:
1. The requested classification is used by construction contractors in the area of the project. (The area is usually defined as the county where the project is located).
  2. The work that will be performed by the requested classification is not already performed by another classification that is already on the wage decision. (In other words, if there already is an Electrician classification and wage rate on the wage decision you can't request another Electrician classification and rate.)
  3. The proposed wage rate for the requested classification "fits" with the other wage rates already on the wage decision. (For example, the wage rate proposed for a trade classification such as Electrician must be at least as much as the lowest wage rate for other trade classifications already contained in the wage decision.) And,
  4. The workers that will be employed in the added classification (if it is known who the workers are/will be), or the workers' representatives, must agree with the proposed wage rate.

---

b. **Making the request.** A request for additional classification and wage rate must be made in writing through the contract administrator. (If the contract administrator is a local agency, the agency will send the request to the HUD Labor Relations staff.) If you are a subcontractor, your request should also go through the prime contractor. All you need to do is identify the work classification that is missing and recommend a wage rate (usually the rate that employer is already paying to the employees performing the work) for that classification. You may also need to describe the work that the new classification will perform.

c. **HUD review.** The HUD Labor Relations field staff will review the requested classification and wage rate to determine whether the request meets the DOL rules outlined in paragraph 2-2(a), above. If additional information or clarification is needed, the staff will contact the prime contractor (or contract administrator for local agency projects) for more information, etc. If the Labor Relations review finds that the request meets the rules, the staff will give preliminary approval on the request and refer it to the DOL for final approval. The staff will send to you a copy of the preliminary approval/referral letter to the DOL.

If the HUD Labor Relations staff doesn't think the request meets the rules and if agreement can't be reached on the proper classification or wage rate for the work described, the HUD Labor Relations staff will not approve the request. In this case, the staff will send your request to the DOL with an explanation why HUD believes that the request shouldn't be approved. The DOL still has final decision authority. You will receive a copy of the disapproval/referral letter to the DOL.

d. **DOL decision.** The DOL will respond to HUD Labor Relations in writing about the additional classification and wage rate request. HUD Labor Relations will notify you of the DOL decision in writing. If the DOL approves the request, the prime contractor must post the approval notice on the job site with the wage decision.

If the DOL does not approve the request, you will be notified about what classification and wage rate should be used for the work in question. You will also receive instructions about how to ask for DOL reconsideration if you still want to try to get your recommendation approved.

It's always a good idea to talk to the contract administrator before submitting an additional classification and wage rate request. The contract administrator can offer suggestions and advice that may save you time and increase the likelihood that DOL will approve your request. Usually, the contract administrator can give you an idea about what the DOL will finally decide.

---

## 2-3 CERTIFIED PAYROLL REPORTS.

You'll need to submit a weekly certified payroll report (CPR) beginning with the first week that your company works on the project and for every week afterward until your firm has completed its work. It's always a good idea to number the payroll reports beginning with #1 and to clearly mark your last payroll for the project "Final."

- a. **Payroll formats.** The easiest form to use is DOL's WH-347, Payroll. A sample copy of the WH-347 is included in the back of this Guide. You may access a fillable version of the WH-347 on-line at HUDClips (see web address in the Appendix). Also, the contract administrator can provide a few copies of the WH-347 that you can reproduce.

You are not required to use Payroll form WH-347. You are welcome to use any other type of payroll, such as computerized formats, as long as it contains all of the information that is required on the WH-347.

- b. **Payroll certifications.** The weekly payrolls are called certified because each payroll is signed and contains language certifying that the information is true and correct. The payroll certification language is on the reverse side of the WH-347. If you are using another type of payroll format you may attach the certification from the back of the WH-347, or any other format which contains the same certification language on the WH-347 (reverse).

DOL's website has Payroll Instructions and the Payroll form WH-347 in a "fillable" PDF format at this address:  
[www.dol.gov/whd/forms/wh347.pdf](http://www.dol.gov/whd/forms/wh347.pdf)

- c. **"No work" payrolls.** "No work" payrolls may be submitted whenever there is a temporary break in your work on the project, for example, if your firm is not needed on the project right now but you will be returning to the job in a couple of weeks. (See tip box, for "no work" payroll exemption!) However, if you know that your firm will not be working on the project for an extended period of time, you may wish to send a short note to the contract administrator to let them know about the break in work and to give an approximate date when your firm will return to the project. If you number payrolls consecutively or if you send a note, you do not need to send "no work" payrolls.

If you number your payroll reports consecutively, you do not need to submit "no work" payrolls!

- 
- d. **Payroll review and submission.** The prime contractor should review each subcontractor's payroll reports for compliance prior to submitting the reports to the contract administrator. Remember, the prime contractor is responsible for the full compliance of all subcontractors on the contract and will be held accountable for any wage restitution that may be found due to any laborer or mechanic that is underpaid and for any liquidated damages that may be assessed for overtime violations. All of the payroll reports for any project must be submitted to the contract administrator through the prime contractor.

An alert prime contractor that reviews subcontractor payroll submissions can detect any misunderstandings early, prevent costly underpayments and protect itself from financial loss should underpayments occur.

- e. **Payroll retention.** Every contractor (including every subcontractor) must keep a complete set of their own payrolls and other basic records such as employee addresses and full SSNs, time cards, tax records, evidence of fringe benefit payments, for a Davis-Bacon project for at least 3 years after the project is completed. The prime contractor must keep a complete set of all of the payrolls for every contractor (including subcontractors) for at least 3 years after completion of the project.
- f. **Payroll inspection.** In addition to submitting payrolls to the contract administrator, every contractor (including subcontractors) must make their own copy of the payrolls and other basic records available for review or copying to any authorized representative from HUD or from DOL.

## 2-4 **DAVIS-BACON DEFINITIONS.**

Before we discuss how to complete the weekly payroll forms, we need to review a couple of definitions. These definitions can help you understand what will be required of you:

- a. **Laborer or mechanic.** "Laborers" and "mechanics" mean anyone who is performing construction work on the project, including trade journeymen (carpenters, plumbers, sheet metal workers, etc.), apprentices, and trainees and, for CWHSSA purposes, watchmen and guards. "Laborers" and "mechanics" are the two groups of workers that must be paid not less than Davis-Bacon wage rates.
1. **Working foremen.** Foremen or supervisors that regularly spend more than 20% of their time performing construction work and do not meet the exclusions in paragraph 2 below are covered "laborers" and "mechanics" for labor standards purposes for the time spent performing construction work.
  2. **Exclusions.** People whose duties are primarily administrative, executive or clerical are not laborers or mechanics. Examples include superintendents, office staff, timekeepers, messengers, etc. (Contact the contract administrator if you have any questions about whether a particular employee is excluded.)

- 
- b. **Employee.** Every person who performs the work of a laborer or mechanic is “employed” regardless of any contractual relationship which may be alleged to exist between a contractor or subcontractor and such person. This means that even if there is a contract between a contractor and a worker, the contractor must make sure that the worker is paid at least as much as the wage rate on the wage decision for the classification of work they perform. Note that there are no exceptions to the prevailing wage requirements for relatives or for self-employed laborers and mechanics.

For more information about working subcontractors, ask the contract administrator or your HUD Labor Relations Field Staff for a copy of Labor Relations Letter LR-96-01, Labor standards compliance requirements for self-employed laborers and mechanics. Labor Relations Letters and other helpful Labor Relations publications are available at HUD’s Labor Relations web site (see the list of web site addresses in the Appendix).

- c. **Apprentices and trainees.** The only workers who can be paid less than the wage rate on the wage decision for their work classification are “apprentices” and “trainees” registered in approved apprenticeship or training programs. Approved programs are those which have been registered with the DOL or a DOL-recognized State Apprenticeship Council (SAC). Apprentices and trainees are paid wage rates in accordance with the wage schedule in the approved program.

Most often, the apprentice/trainee wage rate is expressed as a series of percentages tied to the amount of time spent in the program. For example, 0-6 months: 65%; 6 months - 1 year: 70%; etc. The percentage is applied to the journeyman’s wage rate. On Davis-Bacon projects, the percentage must be applied to the journeyman’s wage rate on the applicable wage decision for that craft.

1. **Probationary apprentice.** A “probationary apprentice” can be paid as an apprentice (less than the rate on the wage decision) if the DOL or SAC has certified that the person is eligible for probationary employment as an apprentice.
2. **Pre-apprentice.** A “pre-apprentice”, that is, someone who is not registered in a program and who hasn’t been DOL- or SAC-certified for probationary apprenticeship is not considered to be an “apprentice” and must be paid the full journeyman’s rate on the wage decision for the classification of work they perform.
3. **Ratio of apprentices and trainees to journeymen.** The maximum number of apprentices or trainees that you can use on the job site cannot exceed the ratio of apprentices or trainees to journeymen allowed in the approved program.

---

d. **Prevailing wages or wage rates.** Prevailing wage rates are the wage rates listed on the wage decision for the project. The wage decision will list a minimum basic hourly rate of pay for each work classification. Some wage decisions include fringe benefits which are usually listed as an hourly fringe rate. If the wage decision includes a fringe benefit rate for a classification, you will need to add the fringe benefit rate to the basic hourly rate unless you provide bona fide fringe benefits for your employees.

1. **Piece-work.** Some employees are hired on a piece-work basis, that is, the employee's earnings are determined by a factor of work produced. For example, a Drywall Hanger's earnings may be calculated based upon the square feet of sheetrock actually hung, a Painter's earnings may be based upon the number of units painted. Employers may calculate weekly earnings based upon piece rates provided the weekly earnings are sufficient to satisfy the wage rate requirement based upon actual hours, including any overtime, worked. Accurate time records must be maintained for any piece-work employees. If the weekly piece rate earnings are not sufficient, the employer must recompute weekly earnings based upon the actual hours worked and the rate on the wage decision for the work classification(s) involved.

e. **Fringe benefits** Fringe benefits can include health insurance premiums, retirement contributions, life insurance, vacation and other paid leave as well as some contributions to training funds. Fringe benefits do not include employer payments or contributions required by other Federal, State or local laws, such as the employer's contribution to Social Security or some disability insurance payments.

Note that the total hourly wage rate paid to any laborer or mechanic (basic wage or basic wage plus fringe benefits) may be no less than the total wage rate (basic wage or basic wage plus fringe benefits) on the wage decision for their craft. If the value of the fringe benefit(s) you provide is less than the fringe benefit rate on the wage decision, you will need to add the balance of the wage decision fringe benefit rate to the basic rate paid to the employee. For example, if the wage decision requires \$10/hour basic rate plus \$5/hour fringe benefits, you must pay no less than that total (\$15/hour) in the basic rate or basic rate plus whatever fringe benefit you may provide. You can meet this obligation in several ways: you could pay the base wage and fringe benefits as stated in the wage decision, or you could pay \$15 in base wage with no fringe benefits, or you could pay \$12 basic plus \$3 fringe benefits. You can also off-set the amount of the base wage if you pay more in fringe benefits such as by paying or \$9 basic plus \$6 fringe benefits; as long as you meet the total amount. The amount of the base wage that you may off-set with fringe benefits is limited by certain IRS and FLSA requirements.

f. **Overtime.** Overtime hours are defined as all hours worked on the contract in excess of 40 hours in any work week. Overtime hours must be paid at no less than one and one-half times the regular rate of basic pay plus the straight-time rate of any required fringe benefits.

- 
- g. **Deductions.** You may make payroll deductions as permitted by DOL Regulations 29 CFR Part 3. These regulations prohibit the employer from requiring employees to “kick-back” (i.e., give up) any of their earnings. Allowable deductions which do not require prior DOL permission include employee obligations for income taxes, Social Security payments, insurance premiums, retirement, savings accounts, and any other legally-permissible deduction authorized by the employee. Deductions may also be made for payments on judgments and other financial obligations legally imposed against the employee.

Referring, again, to our example above where the wage decision requiring a \$15 total wage obligation (\$10 basic wage plus \$5 fringe benefits) was met by paying \$9 base wage plus \$6 fringe benefits: Note that overtime rates must be based on one and one-half times the basic rate as stated on the wage decision. In the above example, the employer must pay for overtime: \$15/hr (\$9 basic + \$6 fringe) plus \$5 (one-half of \$10, the wage decision basic rate) for a total of \$20 per hour.

- h. **Proper designation of trade.** You must select a work classification on the wage decision for each worker based on the actual type of work he/she performed and you must pay each worker no less than the wage rate on the wage decision for that classification regardless of their level of skill. In other words, if someone is performing carpentry work on the project, they must be paid no less than the wage rate on the wage decision for Carpenters even if they aren't considered by you to be fully trained as a Carpenter. Remember, the only people who can be paid less than the rate for their craft are apprentices and trainees registered in approved programs.
1. **Split-classification.** If you have employees that perform work in more than one trade during a work week, you can pay the wage rates specified for each classification in which work was performed only if you maintain accurate time records showing the amount of time spent in each classification of work. If you do not maintain accurate time records, you must pay these employees the highest wage rate of all of the classifications of work performed.
- i. **Site of work.** The “site of work” is where the Davis-Bacon wage rates apply. Usually, this means the boundaries of the project. “Site of work” can also include other adjacent or virtually adjacent property used by a contractor or subcontractor in the construction of the project, like a fabrication site that is dedicated exclusively, or nearly so, to the project.

---

## SECTION II - REPORTING REQUIREMENTS

### 2-5 COMPLETING A PAYROLL REPORT.

What information has to be reported on the payroll form? The weekly payroll form doesn't ask for any information that you don't already need to keep for wage payment and tax purposes. For example, you need to know each employee's name; his or her work classification (who is working for you and what do they do?), the hours worked during the week, his or her rate of pay, the gross amount earned (how much did they earn?), the amounts of any deductions for taxes, etc., and the net amount paid (how much should the paycheck be made out for?). No more information than you need to know in order to manage your work crew and make certain they are paid properly. And, certainly, no more information than you need to keep for IRS, Social Security and other tax and employment purposes.

For many contractors, the Weekly Certified Payroll is the only Davis-Bacon paperwork you need to submit!

You are required to submit certified payrolls to illustrate and document that you have complied with the prevailing wage requirements. The purpose of the contract administrator's review of your payrolls is to verify your compliance. Clearer and complete payroll reports will permit the contract administrator to complete reviews of your payroll reports quickly.

- a. **Project and contractor/subcontractor information.** Each payroll must identify the contractor or subcontractor's name and address, the project name and number, and the week ending date. Indicate the week dates in the spaces provided. Numbering payrolls is optional but strongly recommended.
- b. **Employee information.** Effective January 18, 2009, payrolls shall not report employee addresses or full Social Security Numbers (SSNs). Instead, the first payroll on which each employee appears shall include the employee's name and an individually identifying number, usually the last 4 digits of the employee's SSN. Afterward, the identifying number does not need to be reported unless it is necessary to distinguish between employees, e.g., if two employees have the same name.

Employers (prime contractors and subcontractors) must maintain the current address and full SSN for each employee and must provide this information upon request to the contracting agency or other authorized representative responsible for federal labor standards compliance monitoring. Prime contractors may require a subcontractor(s) to provide this information for the prime contractor's records. DOL has modified form WH-347, Payroll, to accommodate these reporting requirements.

- c. **Work classification.** Each employee must be classified in accordance with the wage decision based on the type of work they actually perform.

- 
1. **Apprentices or trainees.** The first payroll on which any apprentice or trainee appears must be accompanied by a copy of that apprentice's or trainee's registration in a registered or approved program. A copy of the portions of the registered or approved program pertaining to the wage rates and ratios shall also accompany the first payroll on which the first apprentice or trainee appears.
  2. **Split classifications.** For an employee that worked in a split classification, make a separate entry for each classification of work performed distributing the hours of work to each classification, accordingly, and reflecting the rate of pay and gross earnings for each classification. Deductions and net pay may be based upon the total gross amount earned for all classifications.
- d. **Hours worked.** The payroll should show ONLY the regular and overtime hours worked on this project. Show both the daily and total weekly hours for each employee. If an employee performs work at job sites other than the project for which the payroll is prepared, those "other job" hours should not be reported on the payroll. In these cases, you should list the employee's name, classification, hours for this project only, the rate of pay and gross earnings for this project, and the gross earned for all projects. Deductions and net pay may be based upon the employee's total earnings (for all projects) for the week.
- e. **Rate of pay.** Show the basic hourly rate of pay for each employee for this project. If the wage decision includes a fringe benefit and you do not participate in approved fringe benefit programs, add the fringe benefit rate to the basic hourly rate of pay. Also list the overtime rate if overtime hours were worked.
1. **Piece-work.** For any piece-work employees, the employer must compute an effective hourly rate for each employee each week based upon the employee's piece-work earnings for that week. To compute the effective hourly rate, divide the piece-work earnings by the total number of hours worked, including consideration for any overtime hours.

The effective hourly rate must be reflected on the certified payroll and this hourly rate may be no less than the wage rate (including fringe benefits, if any) on the wage decision for the classification of work performed. It does not matter that the effective hourly rate changes from week-to-week, only that the rate is no less than the rate on the wage decision for the classification of work performed.

Remember, the overtime rate is computed at one and one-half times the basic rate of pay plus any fringe benefits. For example, if the wage decision requires \$10/hour basic plus \$5/hour fringe benefits, the overtime rate would be:  $(\$10 \times 1 \frac{1}{2}) + \$5 = \$20/\text{hour}$ .

- f. **Gross wages earned.** Show the gross amount of wages earned for work performed on this project. Note: For employees with work hours and earnings on other projects, you may show gross wages for this project over gross earnings all projects (for example, \$425.40/\$764.85) and base deductions and net pay on the "all projects" earnings.

- 
- g. **Deductions.** Show the amounts of any deductions from the gross earnings. "Other" deductions should be identified (for example, Savings Account or Loan Repayment). Any voluntary deduction (that is, not required by law or by an order of a proper authority) must be authorized in writing by the employee or provided for in a collective bargaining (union) agreement. A short note signed by the employee is all that is needed and should accompany the first payroll on which the other deduction appears.

Only one employee authorization is needed for recurring (e.g., weekly) other deductions. Written employee authorization is not required for income tax and Social Security deductions.

- h. **Net pay.** Show the net amount of wages paid.
- i. **Statement of compliance.** The Statement of Compliance is the certification. It is located on the reverse side of a standard payroll form (WH-347). Be sure to complete the identifying information at the top, particularly if you are attaching the Statement of Compliance to an alternate payroll form such as a computer payroll. Also, you must check either 4(a) or 4(b) if the wage decision contains a fringe benefit. Checking 4(a) indicates that you are paying required fringe benefits to approved plans or programs; and 4(b) indicates that you are paying any required fringe benefit amounts directly to the employee by adding the fringe benefit rate to the basic hourly rate of pay. If you are paying a portion of the required fringe benefit to programs and the balance directly to the employee, explain those differences in box 4(c).

Only one Statement of Compliance is required for each employer's weekly payroll no matter how many pages are needed to report the employee data.

- j. **Signature.** Make sure the payroll is signed with an original signature in ink. The payroll must be signed by a principal of the firm (owner or officer such as the president, treasurer or payroll administrator) or by an authorized agent (a person authorized by a principal in writing to sign the payroll reports). Signature authorization (for persons other than a principal) should be submitted with the first payroll signed by such an agent. Signatures in pencil; signature stamps; xerox, pdf and other facsimiles are not acceptable.

---

## SECTION III - PAYROLL REVIEWS AND CORRECTIONS

### 2-6 COMPLIANCE REVIEWS.

The contract administrator or other inspector may visit the project site and interview some of the workers concerning their employment on the project. The DOL may also independently conduct its own reviews (see 1-5). In addition, the contract administrator will periodically review payrolls and related submissions, comparing the interview information to the payrolls, to ensure that the labor standards requirements have been met. You will be notified by the contract administrator if these reviews find any discrepancies or errors. You will be given instructions about what steps must be taken to correct any problems.

- a. **On-site interviews.** Every employer (contractor, subcontractor, etc.) must make their employees available for interview at the job site with the contract administrator or other agency representative, or HUD or DOL representative. The interviews are confidential and the employee will be asked about the kind of work they perform and their rate of pay. Every effort will be made to ensure that these interviews cause as little disruption as possible to the on-going work. The interviewer will record the interview information, usually on a form HUD-11, Record of Employee Interview, and forward the interviews to the contract administrator.
- b. **Project payroll reviews.** The contract administrator will compare the information on the interview forms to the corresponding payrolls to ensure that the workers are properly listed on the payrolls for the days and hours worked on the job site, work classification and rate of pay. The contract administrator will also review the payroll submissions to make certain that the payrolls are complete and signed; that employees are paid no less than the wage rate for the work classification shown; apprentice and trainee certifications are submitted (where needed); employee or other authorizations for other deductions are submitted (where needed); etc.

### 2-7 TYPICAL PAYROLL ERRORS AND REQUIRED CORRECTIONS.

The following paragraphs describe common payroll errors and the corrective steps you must take.

- a. **Inadequate payroll information.** If an alternate payroll format used by an employer (such as some computer payrolls) is inadequate, e.g., does not contain all of the necessary information that would be on the optional form WH-347, the employer will be asked to resubmit the payrolls on an acceptable form.
- b. **Missing identification numbers.** If the first payroll on which an employee appears does not contain the employee's individually identifying number, the employer will be asked to supply the missing information. This information can be reported on the next payroll submitted by the employer if the employer is still working on the project. Otherwise, the employer will be asked to submit a correction certified payroll.

- 
- c. **Incomplete payrolls.** If the information on the payroll is not complete, for example, if work classifications or rates of pay are missing, the employer will be asked to send a correction certified payroll.
- d. **Classifications.** If the payrolls show work classifications that do not appear on the wage decision, the employer will be asked to reclassify the employees in accordance with the wage decision or the employer may request an additional classification and wage rate (see 2-2). If reclassification results in underpayment (i.e., the wage rate reported on the payroll is less than the rate required for the new classification), the employer will be asked to pay wage restitution to all affected reclassified employees. (see 2-8 for instructions about wage restitution.)
- e. **Wage rates.** If the wage rates on the payroll are less than the wage rates on the wage decision for the work classifications reported, the employer will be asked to pay wage restitution to all affected employees.
- f. **Apprentices and trainees.** If a copy of the employee's registration or the approved program ratio and wage schedule are not submitted with the first payroll on which an apprentice or trainee appears, the employer will be asked to submit a copy of each apprentice's or trainee's registration and/or the approved program ratio and wage schedule. If the ratio of apprentices or trainees to journeymen on the payroll is greater than the ratio in the approved program, the employer will be asked to pay wage restitution to any excess apprentices or trainees. Also, any apprentice or trainee that is not registered in an approved program must receive the journeyman's wage rate for the classification of work they performed.
- g. **Overtime.** If the employees did not receive at least time and one-half for any overtime hours worked on the project, the following will occur:
1. If the project is subject to CWHSSA overtime requirements, the employer will be asked to pay wage restitution for all overtime hours worked on the project. The employer may also be liable to the United States for liquidated damages computed at \$10 per day per violation. Or,
  2. If the project is not subject to CWHSSA, the employer will be notified of the possible FLSA overtime violations. Also, the contract administrator may refer the matter to the DOL for further review.
- h. **Computations.** If the payroll computations (hours worked times rate of pay) or extensions (deductions, net pay) show frequent errors, the employer will be asked to take greater care. Wage restitution may be required if underpayments resulted from the errors.
- i. **Deductions.** If there are any "Other" deductions that are not identified, or if employee authorization isn't provided, or if there is any unusual (very high, or large number) deduction activity, the employer will be asked to identify the deductions, provide employee authorization or explain unusual deductions, as necessary.

---

HUD does not enforce or attempt to provide advice on employer obligations to make deductions from employee earnings for taxes or Social Security. However, HUD may refer to the IRS or other responsible agency copies of certified payroll reports that show wages paid in gross amounts (i.e., without tax deduction) for its review and appropriate action.

- j. **Fringe benefits.** If the wage decision contains fringe benefits but the payroll does not indicate how fringe benefits were paid [neither 4(a) nor 4(b) is marked on the Statement of Compliance], the employer may be asked to submit correction certified payrolls and will be required to pay wage restitution if underpayments occurred. However, if the basic hourly rates for the employees are at least as much as the total wage rate on the wage decision (basic hourly rate plus the fringe benefit rate), no correction is necessary.
- k. **Signature.** If the payroll Statement of Compliance is not signed or is missing, the employer will be asked to submit a signed Statement of Compliance for each payroll affected. If the Statement of Compliance is signed by a person who is not a principle of the firm and that person has not been authorized by principle to sign, the employer will be asked to provide an authorization or to resubmit the Statement(s) of Compliance bearing the signature of a principle or other authorized signatory.
- l. **On-site interview comparisons.** If the comparison of on-site interviews to the payrolls indicates any discrepancies (for example, the employee does not appear on the payroll for the date of the interview), the employer will be asked to submit a correction certified payroll report.
- m. **Correction certified payroll.** Any and all changes to data on a submitted payroll report must be reported on a certified correction payroll. In no case will a payroll report be returned to the prime contractor or employer for revision.

## 2-8 **RESTITUTION FOR UNDERPAYMENT OF WAGES.**

Where underpayments of wages have occurred, the employer will be required to pay wage restitution to the affected employees. Wage restitution must be paid promptly in the full amounts due, less permissible and authorized deductions. All wages paid to laborers and mechanics for work performed on the project, including wage restitution, must be reported on a certified payroll report.

- a. **Notification** to the Employer/Prime contractor. The contract administrator will notify the employer and/or prime contractor in writing of any underpayments that are found during payroll or other reviews. The contract administrator will describe the underpayments and provide instructions for computing and documenting the restitution to be paid. The employer/prime contractor is allowed 30 days to correct the underpayments. Note that the prime contractor is responsible to the contract administrator for ensuring that restitution is paid. If the employer is a subcontractor, the subcontractor will usually make the computations and restitution payments and furnish the required documentation through the prime contractor.

---

The contract administrator may communicate directly with a subcontractor when the underpayments are plainly evident and the subcontractor is cooperative. It is best to work through the prime contractor when the issues are complex, when there are significant underpayments and/or the subcontractor is not cooperative. In all cases, the subcontractor must ensure that the prime contractor receives a copy of the required corrective documentation.

- b. **Computing wage restitution.** Wage restitution is simply the difference between the wage rate paid to each affected employee and the wage rate required on the wage decision for all hours worked where underpayments occurred. The difference in the wage rates is called the adjustment rate. The adjustment rate times the number of hours involved equals the gross amount of restitution due. You may also compute wage restitution by calculating the total amount of Davis-Bacon wages earned and subtracting the total amount of wages paid. The difference is the amount of back wages due.
- c. **Correction certified payrolls.** The employer will be required to report the restitution paid on a correction certified payroll. The correction payroll will reflect the period of time for which restitution is due (for example, Payrolls #1 through #6; or a beginning date and ending date). The correction payroll will list each employee to whom restitution is due and their work classification; the total number of work hours involved (daily hours are usually not applicable for wage restitution); the adjustment wage rate (the difference between the required wage rate and the wage rate paid); the gross amount of restitution due; deductions and the net amount actually paid. A properly signed Statement of Compliance must accompany the correction payroll.

HUD no longer requires the signature of the employee on the correction payroll to evidence employee receipt of restitution payment. In addition, except in the most extraordinary cases, HUD no longer requires employers to submit copies of restitution checks (certified, cashiers, canceled or other), or employee-signed receipts or waivers.

- d. **Review of correction CPR.** The contract administrator will review the correction certified payroll to ensure that full restitution was paid. The prime contractor shall be notified in writing of any discrepancies and will be required to make additional payments, if needed, documented on a correction certified payroll within 30 days.
- e. **Unfound workers.** Sometimes, wage restitution cannot be paid to an affected employee because, for example, the employee has moved and can't be located. After wage restitution has been paid to all of the workers who could be located, the employer must submit a list of any workers who could not be found and paid (i.e., unfound workers) providing their names, Social Security Numbers, last known addresses and the gross amount due. In such cases, at the end of the project the prime contractor will be required

---

to place in a deposit or escrow account an amount equal to the total gross amount of restitution that could not be paid because the employee(s) could not be located. The contract administrator will continue attempts to locate the unfound workers for 3 years after the completion of the project. After 3 years, any amount remaining in the account for unfound workers will be credited and/or forwarded by the contract administrator to HUD.

---

## CHAPTER 3      LABOR STANDARDS DISPUTES, ADMINISTRATIVE REVIEWS, WITHHOLDING, DEPOSITS AND ESCROW ACCOUNTS, AND SANCTIONS

### WHAT HAPPENS WHEN THINGS GO WRONG?

#### 3-1      INTRODUCTION.

Even in the best of circumstances, things can go wrong. In a Davis-Bacon context, "things going wrong" usually means there's a difference of opinion or a dispute about whether and to what extent underpayments have occurred. These disputes are usually between the contract administrator and one or more employers (the prime contractor and/or a subcontractor). The dispute may involve something simple such as an additional classification request that is pending before the DOL; or something as significant as investigative findings following a complaint of underpayment. This chapter discusses some of what you may expect and what you can do to make your views known and to lessen any delays in resolving the problem or issue.

#### 3-2      ADMINISTRATIVE REVIEW ON LABOR STANDARDS DISPUTES.

As mentioned in the Introduction above, a dispute about labor standards and compliance can arise for a number of reasons. The labor standards clauses in your contract and DOL regulations provide for administrative review of issues where there is a difference of views between the contract administrator and any employer. The most common circumstances include:

- a. Additional classifications and wage rates. Additional classification and wage rate requests are sometimes denied by the DOL. An employer that is dissatisfied with the denial can request reconsideration by the DOL Wage and Hour Administrator. The employer may continue to pay the wage rate, as requested, until a final decision is rendered on the matter. When the final decision is known, the employer will be required to pay any additional wages that may be necessary to satisfy the wage rate that is established.
  1. Reconsideration. The DOL normally identifies the reasons for denial in its response to the request. Any interested person (for example, the contract administrator, employer, representatives of the employees) may request reconsideration of the decision on the additional classification request. The request for reconsideration must be made in writing and must thoroughly address the denial reasons identified by the DOL. Employer requests for reconsideration should be made through the contract administrator but may be made directly to the DOL. (See 2-2(d), and also DOL Regulations 29 CFR 1.8.) All requests initiated by or made through the contract administrator or HUD must be submitted through the HUD Headquarters Office of Labor Relations.

- 
2. **Administrative Review Board.** Any interested party may request a review of the Administrator's decision on reconsideration by the DOL's Administrative Review Board. DOL regulations 29 CFR Part 7 explain the procedures for such reviews. (See also 29 CFR 1.9.)

- b. **Findings of underpayment.** Compliance reviews and other follow-up enforcement actions may result in findings of underpayment. The primary goal in every case and at every step in this process is to reach agreements about who may have been underpaid and how much wage restitution may be due and, of course, to promptly deliver restitution to any underpaid workers. The contract administrator will usually work informally with you to reach such agreements. You will have an opportunity to provide additional information to the contract administrator that may explain apparent inconsistencies and/or resolve the discrepancies.

If informal exchanges do not result in agreement, the final determination and schedule of back wages due will be presented to you in writing and you will be permitted 30 days in which to correct the underpayment(s) or to request a hearing on the matter before the DOL. The request for hearing must be made in writing through the contract administrator and must explain what findings are in dispute and the reasons. In such cases, HUD is required to submit a report to DOL for review and further consideration. All requests for DOL hearing must be submitted through the HUD Headquarters Office of Labor Relations.

1. **DOL review.** The DOL will review the contract administrator's report and the arguments against the findings presented in the hearing request. The DOL may affirm or modify the findings based upon the materials presented. You will be notified in writing by the DOL of the results of its review. If DOL concludes that violations have occurred, you will be given an opportunity to correct any underpayments or to request a hearing before a DOL Administrative Law Judge (ALJ). (See DOL Regulations 29 CFR 5.11 (b) and 29 CFR Part 6, Rules of Practice for Administrative Proceedings.)
2. **Administrative Review Board.** Contractors and/or subcontractors may request a review by the Administrative Review Board of the decision(s) rendered by the DOL ALJ in the administrative hearing process. See DOL regulations 29 CFR Part 7 for more information about this proceeding.

### 3-3 **WITHHOLDING.**

The contract administrator shall cause withholding from payments due to the prime contractor to ensure the payment of wages which are believed to be due and unpaid, for example, if wage underpayments or other violations are not corrected within 30 days after written notification to the prime contractor. DOL may also direct the withholding of contract payments for alleged wage underpayments. Withholding is considered to be serious and is not taken unless warranted. If withholding is deemed necessary, you will be notified in writing. Only the amounts needed to meet the contractor's (and/or subcontractors') liability shall be withheld.

---

### 3-4 DEPOSITS AND ESCROWS.

In every case, we attempt to complete compliance actions and resolve any disputes before the project is completed and final payments are made. Sometimes, corrective actions or disputes continue after completion and provisions must be made to ensure that funds are available to pay any wage restitution that is ultimately found due. In these cases, we allow projects to proceed to final closing and final payments provided the prime contractor deposits an amount equal to the potential liability for wage restitution and liquidated damages, if necessary, in a special account. The deposit or escrow account is controlled by the contract administrator. When a final decision is rendered, the contract administrator makes disbursements from the account in accordance with the decision. Deposit/escrow accounts are established for one or more of the following reasons:

Remember, the prime contractor is responsible and will be held liable for any wage restitution that is due to any worker employed in the construction of the project, including workers employed by subcontractors and any lower-tier subcontractors. See 1-4, Responsibility of the Principal Contractor, and 2-8, Restitution for Underpayment of Wages.

- a. **Where the parties have agreed to amounts of wage restitution that are due** but the employer hasn't furnished evidence yet that all of the underpaid workers have received their back wages, e.g., some of the workers have moved and could not be located. The amount of the deposit is equal to the total gross amount of restitution due to workers lacking payment evidence. As these workers are paid and proper documentation is provided to the contract administrator, amounts corresponding to the documented payments are returned to the depositor. Amounts for any workers who cannot be located are held in the deposit/escrow account for three years and disposed as described in 2-8(f) of this Guide.
- b. **Where underpayments are suspected or alleged and an investigation has not yet been completed.** The deposit is equal to the amount of wage restitution and any liquidated damages, if applicable, that are estimated to be due. If the final determination of wages due is less than the amount estimated and placed in the escrow account, the escrow will be reduced to the final amount and the difference will be returned to the depositor.

If the parties agree to the investigative findings, the amounts due to the workers will be paid by the employer. As these workers are paid and proper documentation is provided to the contract administrator, the gross amounts corresponding to the documented payments are returned to the depositor.

1. If the employer is unable to make the payments to the workers, e.g., lacks the funds necessary, the contract administrator may make disbursements directly to the workers in the net amounts calculated by the employer. The amounts withheld from the workers for tax deduction will be returned to the employer as payments to workers are made. The employer shall be responsible for reporting and transmitting withholdings to the appropriate agencies.

- 
2. If the employer is not cooperating in the resolution, the contract administrator shall make disbursements to the workers in accordance with the schedule of wages due. Amounts for unfound workers will be retained as described above (See 2-8(f) and 3-4(a)).

If the parties do not agree and an administrative hearing is requested, the escrow will be maintained as explained in 3-4(c), below.

Remember, if you have any questions or need assistance concerning labor standards requirements help is always available. Contact the contract administrator for the project you're working on or the HUD Field Labor Relations staff in your area.

- c. **Where the parties are waiting for the outcome of an administrative hearing** that has been or will be requested contesting a final determination of wages due. The deposit shall be equal to the amount of wage restitution and liquidated damages, if applicable, that have been determined due. Once a final decision is rendered, disbursements from the escrow account are made in accordance with the decision.

### 3-5 **ADMINISTRATIVE SANCTIONS.**

Contractors and/or subcontractors that violate the labor standards provisions may face administrative sanctions imposed by HUD and/or DOL.

- a. **DOL debarment.** Contractors and/or subcontractors that are found by the Secretary of Labor to be in aggravated or willful violation of the labor standards provisions of the Davis-Bacon and Related Acts (DBRA) will be ineligible (debarred) to participate in any DBRA or Davis-Bacon Act contracts for up to 3 years. Debarment includes the contractor or subcontractor and any firm, corporation, partnership or association in which the contractor or subcontractor has a substantial interest. Debarment proceedings can be recommended by the contract administrator or can be initiated by the DOL. Debarment proceedings are described in DOL regulations 29 CFR 5.12.
- b. **HUD sanctions.** HUD sanctions may include Limited Denials of Participation (LDPs), debarments and suspensions.
  1. **Limited Denial of Participation.** HUD may issue to the employer a limited denial of participation (LDP) which prohibits the employer from further participation in HUD programs for a period up to one year. The LDP is usually effective for the HUD program in which the violation occurred and for the geographic jurisdiction of the issuing HUD Office. HUD regulations concerning LDP's are found at 24 CFR 24.700-24.714.

- 
2. **Debarment and suspensions.** In certain circumstances, HUD may initiate its own debarment or suspension proceedings against a contractor and/or subcontractor in connection with improper actions regarding Davis-Bacon obligations. For example, HUD may initiate debarment where a contractor has been convicted for making false statements (such as false statements on certified payrolls or other prevailing wage certifications) or may initiate suspension where a contractor has been indicted for making false statements. HUD regulations concerning debarment and suspension are found at 24 CFR Part 24.

**3-6 FALSIFICATION OF CERTIFIED PAYROLL REPORTS.**

Contractors and/or subcontractors that are found to have willfully falsified payroll reports (Statements of Compliance), including correction certified payroll reports, may be subject to civil or criminal prosecution. Penalties may be imposed of \$1,000 and/or one year in prison for each false statement (see Section 1001 of Title 18 and Section 231 of Title 31 of the United States Code).

Remember, if you have any questions or need assistance concerning labor standards requirements help is always available. Contact the contract administrator for the project you're working on or the HUD Field Labor Relations staff in your area.

---

## ACRONYMS AND SYMBOLS

<b>CDBG -</b>	<b>Community Development Block Grant</b>
<b>CFR -</b>	<b>Code of Federal Regulations</b>
<b>CPR -</b>	<b>Certified Payroll Report</b>
<b>CWHSSA -</b>	<b>Contract Work Hours and Safety Standards Act</b>
<b>DBA -</b>	<b>Davis-Bacon Act</b>
<b>DBRA -</b>	<b>Davis-Bacon and Related Acts</b>
<b>DOL -</b>	<b>Department of Labor</b>
<b>FHA -</b>	<b>Federal Housing Administration</b>
<b>FLSA -</b>	<b>Fair Labor Standards Act</b>
<b>HUD -</b>	<b>Housing and Urban Development (Department of)</b>
<b>IHA -</b>	<b>Indian Housing Authority</b>
<b>LCA -</b>	<b>Local Contracting Agency</b>
<b>LDP -</b>	<b>Limited Denial of Participation</b>
<b>O/T -</b>	<b>Overtime</b>
<b>PHA -</b>	<b>Public Housing Agency</b>
<b>S/T -</b>	<b>Straight-time</b>
<b>SAC -</b>	<b>State Apprenticeship Council/Agency</b>
<b>TDHE -</b>	<b>Tribally-Designated Housing Entity</b>
<b>§ -</b>	<b>Section</b>
<b>¶ -</b>	<b>Paragraph</b>

---

## DAVIS-BACON - RELATED WEB SITES\*

HUD Office of Labor Relations:  
[www.hud.gov/offices/olr](http://www.hud.gov/offices/olr)

HUD Regulations:  
<http://www.gpo.gov/fdsys/browse/collectionCfr.action?collectionCode=CFR>

HUDClips (HUD Forms and Publications):  
[www.hud.gov/offices/adm/hudclips/index.cfm](http://www.hud.gov/offices/adm/hudclips/index.cfm)

DOL Davis-Bacon and Related Acts Homepage:  
<http://www.dol.gov/whd/contracts/dbra.htm>

DOL Regulations:  
<http://www.gpo.gov/fdsys/browse/collectionCfr.action?collectionCode=CFR>

Davis-Bacon Wage Decisions:  
[www.wdol.gov](http://www.wdol.gov)

DOL Forms:  
[www.dol.gov/whd/programs/dbra/forms.htm](http://www.dol.gov/whd/programs/dbra/forms.htm)

**\*Web addresses active as of January 2012**

<b>Project Wage Rate Sheet</b>			U.S. Department of Housing and Urban Development Office of Labor Relations			
Project Name:			Wage Decision Number/Modification Number:			
Project Number:			Project County:			
Work Classification	Basic Hourly Rate (BHR)	Fringe Benefits	Total Hourly Wage Rate	Laborers Fringe Benefits		\$
				Group #	BHR	
Bricklayers			\$			Total Wage
Carpenters			\$			\$
Cement Masons			\$			\$
Drywall Hangers			\$			\$
Electricians			\$			\$
Iron Workers			\$			\$
Painters			\$	Operators Fringe Benefits:		\$
Plumbers			\$	Group #	BHR	Total Wage
Roofers			\$			\$
Sheet Metal Workers			\$			\$
Soft Floor Workers			\$			\$
Tapers			\$			\$
Tile Setters			\$	Truck Drivers Fringe Benefits:		\$
Other Classifications				Group #	BHR	Total Wage
			\$			
			\$			
			\$			
<b>Additional Classifications (HUD Form 4230-A)</b>						
Work Classification	Basic Hourly Rate (BHR)	Fringe Benefits	Total Hourly Wage Rate	Date of HUD Submission to DOL		Date of DOL Approval
			\$			
			\$			
			\$			





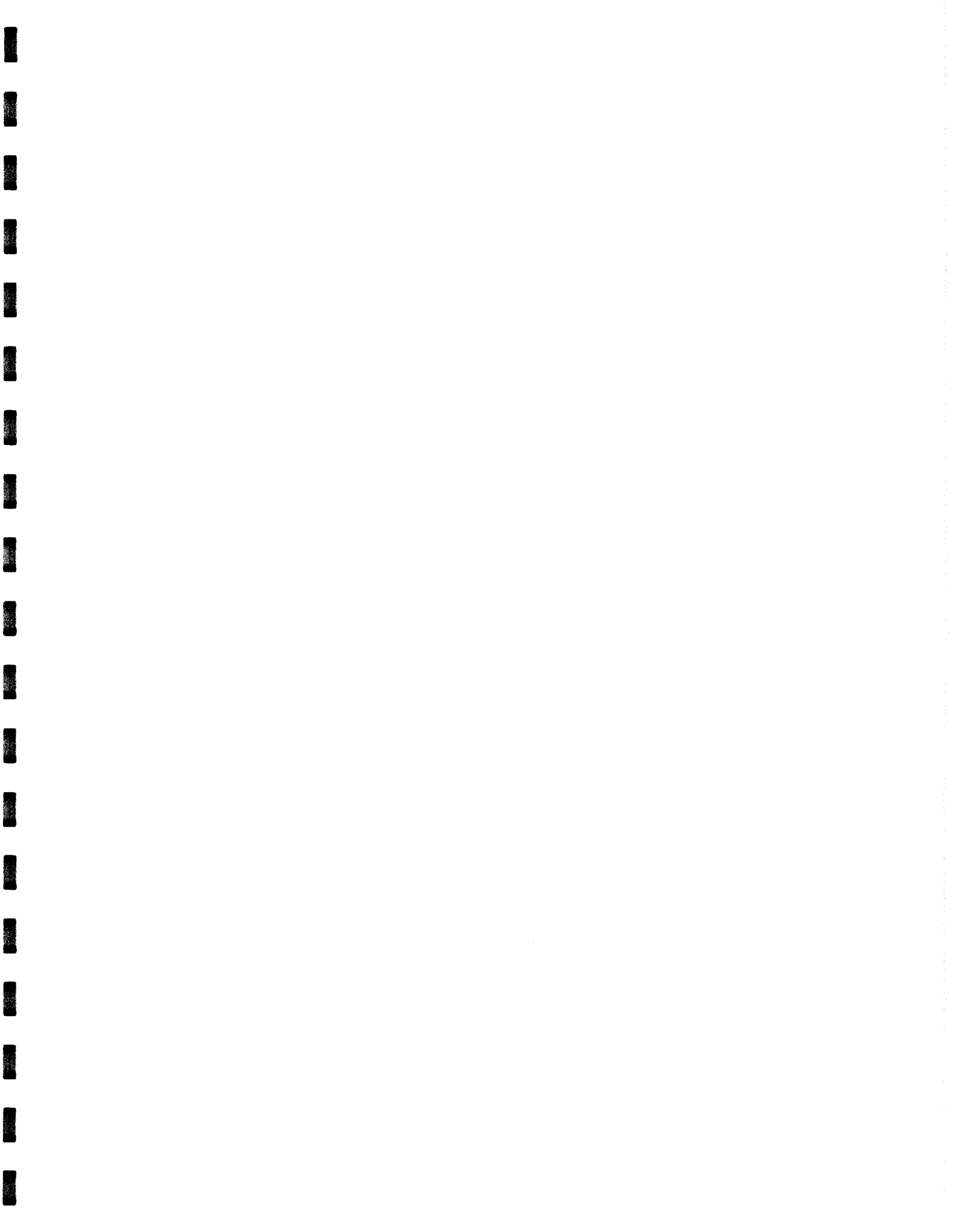

U.S. Department of Housing and Urban Development  
Office of Departmental Operations and Coordination  
Washington, DC 20410

Email: [www.OfficeofLaborRelations@hud.gov](mailto:www.OfficeofLaborRelations@hud.gov)

**Labor Relations Desk Guide**  
**LR01.DG**



Border Colonia Access Program  
Checklist for Documentation Required for Road Construction

Contractor: \_\_\_\_\_  
 Contract Amount: \_\_\_\_\_  
 Project/Precinct: \_\_\_\_\_  
 Owner's Contract No.: \_\_\_\_\_

Item	Required Documents	Submitted & Reviewed	Approved	Comments:
1	Approval to Bid (Purchasing)			
2	Contract - Signed and Executed			
3	Gen. Liability Insurance - (Expiration Date)			
4	Automobile Liab. Insurance - (Expiration Date)			
5	Worker's Comp. & Empl. Liab. (Expiration Date)			
6	Notice to Proceed			
7	Material Sample & Testing Table Sent to Auditor's Office			
8	Application and Certification of Payment (A)			
9	Schedule of Values a/k/a 1257/1258			
10	Estimate Quantity Update Worksheet			
11	List of Suppliers and Sub-contractors			
12	Partial Waiver of Liens (Sub-contractors/suppliers)			
13	TxDot Form 252 Contract Time Statement			
14	Payroll Report w/signed Wage Form			
15	Change Order (Requires TxDot Concurrence)			
16	Punch List			
17	Certificate of Construction Completion			
18	Approval by Commissioner's Court			
19	Contractor's Affidavit of Release (Waiver) of Liens (with power of attorney)(B)			
20	Affidavit of Payment of Debts & Claims-lien bond & indemnity bonds(w/power of attorney)(B)			
21	Consent of Surety to Final Payment(with power of attorney)(B)			
22	Final Blue Prints			

## CHANGE ORDER NUMBER ONE(1)

Project: \_\_\_\_\_

DATE OF ISSUANCE: \_\_\_\_\_ EFFECTIVE DATE: \_\_\_\_\_

OWNER: \_\_\_\_\_  
 OWNER'S CONTRACT NO: \_\_\_\_\_

CONTRACTOR: \_\_\_\_\_ ENGINEER: \_\_\_\_\_  
 \_\_\_\_\_  
 \_\_\_\_\_

You are directed to make the following changes in the Contract Documents.

Description: 1.  
 2.  
 3.  
 4.  
 5.  
 6.

Reason for Change Order: 1.  
 2.  
 3.  
 4.  
 5.  
 6.

Attachments:

CHANGE IN CONTRACT PRICE:		CHANGE IN CONTRACT TIME:	
Original Contract Price		Original Contract Time for	
\$ 0.00		Substantial Completion:	0 <small>calendar days or dates</small>
Net Changes from previous Change Order		Net Change from previous Change Orders	0 <small>calendar days</small>
\$ 0.00		Contract Time prior to this Change Order	
Contract Price prior to this Change Order		Substantial Completion:	0 <small>calendar days or dates</small>
\$ 0.00		Net Increase(decrease) of this Change Order	0 <small>calendar days</small>
Net Increase(decrease) of this Change Order		Contract Time with all approved Change Orders	
\$ 0.00		Substantial Completion:	0 <small>calendar days or dates</small>
Contract Price with all approved Change Orders	Net % increase(decrease) from original contract price. #DIV/O! %		
\$ 0.00			

**RECOMMENDED:**  
 By: \_\_\_\_\_  
Engineer (Authorized Signature)

**APPROVED:**  
 By: \_\_\_\_\_  
Owner (Authorized Signature)

**ACCEPTED:**  
 By: \_\_\_\_\_  
Contractor (Authorized Signature)

Date: \_\_\_\_\_

Date: \_\_\_\_\_

Date: \_\_\_\_\_

**Exhibit E-B**

APPLICATION FOR PAYMENT NO.

To: \_\_\_\_\_ (OWNER)
From: \_\_\_\_\_ (CONTRACTOR)
Contract: \_\_\_\_\_
Project: \_\_\_\_\_
Owner's Contract No. \_\_\_\_\_ Engineer's Project No. \_\_\_\_\_
For Work accomplished through the date of: \_\_\_\_\_

- 1. Original Contract Price: \_\_\_\_\_
2. Net change by Change Order and Written Agreements(+or-): \_\_\_\_\_
3. Current Contract Price (1 plus 2): \_\_\_\_\_
4. Total completed and stored to date: \_\_\_\_\_
5. Retainage (per Agreement): \_\_\_\_\_
10% of completed Work: \_\_\_\_\_
of stored material \_\_\_\_\_
Total Retainage: \_\_\_\_\_
6. Total completed and stored to date less retainage (4 minus 5) \_\_\_\_\_
7. Less previous Application for Payments: \_\_\_\_\_
8. AMOUNT DUE THIS APPLICATION (6 MINUS 7) \_\_\_\_\_

Accompanying Documentation:

CONTRACTOR'S Certification:

The undersigned CONTRACTOR certifies that (1) all previous progress payments received from OWNER on account of Work done under the Contract referred to above have been applied on account to discharge CONTRACTOR'S legitimate obligations incurred in connection with Work covered by prior Applications for Payment numbered 1 through 2 inclusive: (2) title of all Work, materials and equipment incorporated in said Work or otherwise listed in or covered by this Application for Payment will pass to OWNER at time of payment free and clear of all Liens, security interests and encumbrances (except such as are covered by a Bond acceptable to OWNER indemnifying OWNER against any such Lien, security interest or encumbrance); and (3) all Work covered by this Application for Payments is in accordance with the Contract Documents and not defective.

Date \_\_\_\_\_

\_\_\_\_\_  
CONTRACTOR

State of \_\_\_\_\_

County of \_\_\_\_\_

Subscribed and sworn to before me this \_\_\_\_\_

day of \_\_\_\_\_

By: \_\_\_\_\_

\_\_\_\_\_  
Notary Public

My Commission expires: \_\_\_\_\_

Payment of the above AMOUNT DUE THIS APPLICATION is recommended.

Date \_\_\_\_\_

\_\_\_\_\_  
ENGINEER

By: \_\_\_\_\_

**Estimate Quantity Update Worksheet**

Date: \_\_\_\_\_  
 Contractor: \_\_\_\_\_  
 Control: \_\_\_\_\_  
 Project No.: \_\_\_\_\_  
 County: \_\_\_\_\_  
 Est. No.: 1  
 Work Type: Paving & Drainage  
 Limits: \_\_\_\_\_  
 From: \_\_\_\_\_  
 To: \_\_\_\_\_  
 Date Began: ?  
 Contract Time: 120  
 Time Charged: 90  
 % Time Used: 75.00%  
 #DIV/0!  
 Work Done this Mo.: \_\_\_\_\_  
 % Complete: \_\_\_\_\_

ITEM NO.	DESCRIPTION	UNIT	PROJECT QTY	Unit Price	Project Amount	FIRST MONTH			SECOND MONTH			THIRD MONTH		
						MONTHLY QUANTITY	QTY to Date	Item Cost (Monthly)	MONTHLY QUANTITY	QTY to Date	Item Cost (Monthly)	MONTHLY QUANTITY	QTY to Date	Item Cost (Monthly)
<b>(901) ADMINISTRATIVE</b>														
<b>(902) PRELIMINARY ENGINEERING</b>														
<b>(903) CONSTRUCTION ENGINEERING</b>														
<b>(904) RIGHT-OF-WAY</b>														
<b>(905) ROADWAY CONSTRUCTION</b>														
100	PREP ROW	Sia	1,100	\$1,800.00	\$1,980.00	1,000	1,000	\$0.00	0	0	\$0.00	0	0	0.00
110	BACKFILL (TY A)	Sia	1,000	\$600.00	\$600.00	0	0	\$0.00	0	0	\$0.00	0	0	0.00
247	FLEX BASE (RDWY DEL)(TY D GR 6 CL 4)	CY	76,000	\$28.00	\$2,128.00	0	0	\$0.00	0	0	\$0.00	0	0	0.00
260	LIME (TY A SLURRY) OR (TY B)	TON	1036.000	\$2.00	\$2,072.00	0	0	\$0.00	0	0	\$0.00	0	0	0.00
260	LIME TREAT SUBGR (DC)(12")	SY	0.000	\$6,000.00	\$0.00	0	0	\$0.00	0	0	\$0.00	0	0	0.00
262	LIME (TY A SLURRY) OR (TY B)	TON	7,800	\$3,000.00	\$23,400.00	0	0	\$0.00	0	0	\$0.00	0	0	0.00
262	LIME TRT FOR BS CRS (NEW/EXT BS)(DC)(6")	SY	1277.800	\$6.00	\$7,666.80	0	0	\$0.00	0	0	\$0.00	0	0	0.00
310	ASPH MATRL (MC-30)	GAL	246.7	\$6.00	\$1,480.20	0	0	\$0.00	0	0	\$0.00	0	0	0.00
500	MOBILIZATION	LS	1,000	\$3,000.00	\$3,000.00	0	0	\$0.00	0	0	\$0.00	0	0	0.00
502	BARRICADES, SIGNS, AND TRAF HANDLE	MO	1,000	\$1,000.00	\$1,000.00	0	0	\$0.00	0	0	\$0.00	0	0	0.00
529	CONC CURB AND GUTTER (TY A)(BARRIER)	LF	600,000	\$7.50	\$4,500.00	0	0	\$0.00	0	0	\$0.00	0	0	0.00
644	SMALL RDS SGN ASSM (TY A)	EA	2,000	\$300.00	\$600.00	0	0	\$0.00	0	0	\$0.00	0	0	0.00
644	DEL ASM TY A (D-SY)	EA	2,000	\$500.00	\$1,000.00	0	0	\$0.00	0	0	\$0.00	0	0	0.00
658	REFL PAV MKR TY I (Y)(SLD)(4")	LF	4,000,000	\$100.00	\$400,000.00	0	0	\$0.00	0	0	\$0.00	0	0	0.00
666	REFL PAV MKR TY I (Y)(BRK)(4")	LF	400,000	\$0.25	\$100,000.00	0	0	\$0.00	0	0	\$0.00	0	0	0.00
672	RAIS PAV MKR CL B (REFL)(TY II-A-A)	EA	140,000	\$0.25	\$35,000.00	0	0	\$0.00	0	0	\$0.00	0	0	0.00
3146	HOT MIX (TY D)	TON	24,000	\$3.50	\$84,000.00	0	0	\$0.00	0	0	\$0.00	0	0	0.00
5249	TEMP SEDMT CONT FENCE	LF	105.5	\$34.00	\$3,587.00	0	0	\$0.00	0	0	\$0.00	0	0	0.00
<b>(906) DRAINAGE</b>														
464	RC PIPE (CL III)(18")	LF	404,000	\$25.00	\$10,100.00	0	0	\$0.00	0	0	\$0.00	0	0	0.00
464	RC PIPE (CL III)(24")	LF	120,000	\$30.00	\$3,600.00	0	0	\$0.00	0	0	\$0.00	0	0	0.00
465	INLET (COMPL)(TY A)	EA	2,000	\$2,000.00	\$4,000.00	0	0	\$0.00	0	0	\$0.00	0	0	0.00
465	INLET (COMPL)(TY C)	EA	2,000	\$1,500.00	\$3,000.00	0	0	\$0.00	0	0	\$0.00	0	0	0.00
465	MANH (COMPL)(TY M)	EA	1,000	\$2,000.00	\$2,000.00	0	0	\$0.00	0	0	\$0.00	0	0	0.00
465	INLET EXT.	EA	2,000	\$700.00	\$1,400.00	0	0	\$0.00	0	0	\$0.00	0	0	0.00
467	SET (TY II)(18")(RCP)(1.6)	EA	4,000	\$550.00	\$2,200.00	0	0	\$0.00	0	0	\$0.00	0	0	0.00
467	SET (TY II)(24")(RCP)(1.6)	EA	1,000	\$650.00	\$650.00	0	0	\$0.00	0	0	\$0.00	0	0	0.00

Monthly Totals:	\$0.00	\$0.00	\$0.00
ADMINISTRATIVE (901)			
PRELIMINARY ENGINEERING (902)			
CONSTRUCTION ENGINEERING (903)			
RIGHT-OF-WAY (904)			
Roadway (905):	\$0.00	\$0.00	\$0.00
Drainage (906):	\$0.00	\$0.00	\$0.00

Total to Date  
 Roadway (905): \$0.00  
 Drainage (906): \$0.00  
 Total \$0.00

Prepared and Checked By: \_\_\_\_\_  
 Signature: \_\_\_\_\_  
 Printed Name: \_\_\_\_\_  
 Date: \_\_\_\_\_









**PARTIAL/FINAL WAIVER OF LIEN**

THE STATE OF TEXAS

COUNTY OF \_\_\_\_\_

The undersigned contracted with \_\_\_\_\_  
\_\_\_\_\_ to furnish \_\_\_\_\_  
in connection with certain improvements to real property located in \_\_\_\_\_  
County, Texas, and owned by \_\_\_\_\_  
Which improvements are described as follows:

\_\_\_\_\_  
\_\_\_\_\_  
\_\_\_\_\_

In consideration of Pay Estimate No \_\_\_\_\_ in the amount of \_\_\_\_\_  
\_\_\_\_\_ DOLLAR(\$ \_\_\_\_\_) and other good and  
valuable consideration, the receipt and sufficiency of which is hereby acknowledged and  
confessed, the undersigned does hereby waive and release any mechanic's lien or materialmen's  
lien or claims of lien that the undersigned has or hereafter has on the above mentioned real  
property on account of any labor performed or materials furnished or to be furnished or labor  
performed and materials furnished by the undersigned pursuant to the above-mentioned contract  
or any constitutional lien that the undersigned may have.

Undersigned hereby guarantees that all bids for labor performed and/or materials furnished in the  
erection and construction of such improvements on the Property have been fully paid and  
satisfied and Undersigned does further guarantee that if for any reason a lien or liens are filed for  
material or labor against said Property arising out of any bills for material or labor in connection  
with the erection or construction of said improvements thereon, Undersigned will obtain a  
settlement of such lien or liens and a proper release thereof shall be obtained.

\_\_\_\_\_  
CONTRACTOR

BY: \_\_\_\_\_  
TITLE

SWORN TO AND SUBSCRIBED BEFORE ME, on this the \_\_\_\_\_ day of \_\_\_\_\_, 20\_\_ to  
certify which witness my hand and seal of office.

\_\_\_\_\_  
NOTARY PUBLIC in and for the State of Texas  
My Commission Expires: \_\_\_\_\_

**CONTRACTOR'S AFFIDAVIT OF  
PAYMENTS OF DEBTS AND CLAIMS**

<b>PROJECT:</b> <b>OWNER:</b> <b>CONTRACTOR:</b> <b>ENGINEER:</b>	<b>PROJECT NO.</b>
--	--------------------

The Contractor in accordance with the Contract Documents, hereby certifies that, except as listed below, all obligations for all materials and equipment furnished, for all work labor, and services performed, and for all known indebtedness and claims against the Contractor for damages arising in any manner in connection with the performance of the Contract referenced above for which the Owner or his property might in any way be held responsible have been paid in full or have otherwise been satisfied in full.

**EXCEPTIONS:** (If none, write "NONE". The Contractor shall furnish a bond acceptable to the Owner for each exception.)

**CONTRACTOR**

By

Title

Subscribed and sworn to before me this

day of

Notary Public:

My Commission Expires:

**Prevailing Wage Rates  
Certification Statement**

Date \_\_\_\_\_

Project Name \_\_\_\_\_

CSJ# \_\_\_\_\_

Contractor \_\_\_\_\_

Application# \_\_\_\_\_

I, \_\_\_\_\_ do hereby state:  
(Name of Project Director)

1. That a payroll (form WH-347 or similar form) was submitted for contract work Performed for the period covered by the attached application.
2. That a statement of compliance(form WH-347 or similar form) was submitted with the payroll.
3. The certified payroll complies with the classifications and minimum wage rates Stipulated in the contract.
4. That a minimum of one interview was conducted with laborers using Form HUD-11 or similar.

\_\_\_\_\_  
Signature



(b) WHERE FRINGE BENEFITS ARE PAID IN CASH

- Each laborer or mechanic listed in the above referenced payroll has been paid, as indicated on the payroll, an amount not less than the sum of the applicable basic hourly wage rate plus the amount of the required fringe benefits as listed in the contract, except as noted in Section 4(c) below.

(c) EXCEPTIONS

EXCEPTION (CRAFT) EXPLANATION

Date \_\_\_\_\_

I, \_\_\_\_\_ (Name of Signatory Party) \_\_\_\_\_ (Title)

do hereby state:

(1) That I pay or supervise the payment of the persons employed by \_\_\_\_\_

(Contractor or Subcontractor) \_\_\_\_\_ on the \_\_\_\_\_

(Building or Work) \_\_\_\_\_; that during the payroll period commencing on the \_\_\_\_\_

\_\_\_\_\_ day of \_\_\_\_\_, and ending the \_\_\_\_\_ day of \_\_\_\_\_,

all persons employed on said project have been paid the full weekly wages earned, that no rebates have

been or will be made either directly or indirectly to or on behalf of said \_\_\_\_\_

\_\_\_\_\_ (Contractor or Subcontractor) \_\_\_\_\_ from the full

weekly wages earned by any person and that no deductions have been made either directly or indirectly

from the full wages earned by any person, other than permissible deductions as defined in Regulations, Part

3 (29 CFR Subtitle A), issued by the Secretary of Labor under the Copeland Act, as amended (46 Stat. 948,

63 Stat. 108, 72 Stat. 987; 76 Stat. 357; 40 U.S.C. 276c), and described below:

\_\_\_\_\_

\_\_\_\_\_

\_\_\_\_\_

\_\_\_\_\_

\_\_\_\_\_

\_\_\_\_\_

\_\_\_\_\_

\_\_\_\_\_

\_\_\_\_\_

REMARKS:

(2) That any payrolls otherwise under this contract required to be submitted for the above period are correct and complete; that the wage rates for laborers or mechanics contained therein are not less than the applicable wage rates contained in any wage determination incorporated into the contract; that the classifications set forth therein for each laborer or mechanic conform with the work he performed.

(3) That any apprentices employed in the above period are duly registered in a bona fide apprenticeship program registered with a State apprenticeship agency recognized by the Bureau of Apprenticeship and Training, United States Department of Labor, or if no such recognized agency exists in a State, are registered with the Bureau of Apprenticeship and Training, United States Department of Labor.

(4) That: (e) WHERE FRINGE BENEFITS ARE PAID TO APPROVED PLANS, FUNDS, OR PROGRAMS

- In addition to the basic hourly wage rates paid to each laborer or mechanic listed in the above referenced payroll, payments of fringe benefits as listed in the contract have been or will be made to appropriate programs for the benefit of such employees, except as noted in Section 4(c) below.

NAME AND TITLE SIGNATURE

THE WILLFUL FALSIFICATION OF ANY OF THE ABOVE STATEMENTS MAY SUBJECT THE CONTRACTOR OR SUBCONTRACTOR TO CIVIL OR CRIMINAL PROSECUTION. SEE SECTION 1001 OF TITLE 18 AND SECTION 231 OF TITLE 31 OF THE UNITED STATES CODE.

**CERTIFICATE OF CONSTRUCTION COMPETION**

THIS IS TO CERTIFY THAT ON \_\_\_\_\_ DAY OF \_\_\_\_\_ A FINAL INSPECTION was made of the project herein described.

CONTRACT

CONTRACT DATE: \_\_\_\_\_  
 OWNER: \_\_\_\_\_  
 CONSTRUCTION CONTRACTOR: \_\_\_\_\_  
 OF THE CITY OF \_\_\_\_\_ STATE OF \_\_\_\_\_

PROJECT DESCRIPTION

CONSTRUCTION OF \_\_\_\_\_

CONTRACT NO: \_\_\_\_\_  
 Located in or near the City/Precinct Of \_\_\_\_\_

THIS IS TO CERTIFY”

1. That the work has been completed in accordance with the plans and specifications and all addenda, change orders, supplemental agreements thereto, and with the following exceptions:  
 \_\_\_\_\_
2. That the sum of \_\_\_\_\_, deducted from the final payment of the Contractor is a fair and equitable settlement for the foregoing except work.
3. That the contractor has presented a “Certificate of Release” starting under oath, that all claims arising out of the performance of work have been fulfilled, and the Owner is released from all claims arising under or by virtue of said contract.
4. That the CONTRACTOR has presented in behalf of itself and its sureties, satisfactory evidence that it is bound to repair, replace, and make good any faulty workmanship and/or materials discovered in the work within a period of one year from this date, as provided in said contract.
5. Amount of Original Contract \_\_\_\_\_  
 Present Amount of Contract \_\_\_\_\_  
 Total Amount of earned to Date \_\_\_\_\_  
 Less: previous payments \_\_\_\_\_  
 Balance \_\_\_\_\_  
 Authorized deductions \_\_\_\_\_  
 AMOUNTY OF FINAL PAYMENT \_\_\_\_\_

6. That the final payment in the amount of \_\_\_\_\_  
\_\_\_\_\_ is now due and payable.

\_\_\_\_\_  
Engineer's Signature

**CONCURRED BY:**

\_\_\_\_\_  
Contractor's Name

By: \_\_\_\_\_

Title: \_\_\_\_\_

**CONCURRED BY:**

\_\_\_\_\_  
City/Precinct

By: \_\_\_\_\_

Title: \_\_\_\_\_

**CONTRACTOR'S AFFIDAVIT OF RELEASE OF LIENS**

<b>PROJECT:</b> <b>OWNER:</b> <b>CONTRACTOR:</b> <b>ENGINEER:</b>	<b>PROJECT NO.</b>
--	--------------------

The Contractor, in accordance with the Contract Documents, and in consideration for the full and final payment to the Contractor for all services in connection with the project, does hereby waive and release any and all liens, or any and all claims to liens which the Contractor may have on or affecting the project as a result of its contract(s) for the Project or for performing labor and/or furnishing materials in any way connected with the construction of any aspect of the project. The Contractor further certifies and warrants that all subcontractors of labor and/or materials for the Project, except as listed below, have been paid in full for all labor and/or materials supplied to, for through or at the direct or indirect request of the Contractor prior to, through and including the date of this affidavit.

**EXCEPTIONS:** (If none, write "NONE". The Contractor shall furnish a bond acceptable to the Owner for each exception.)

**CONTRACTOR**

By \_\_\_\_\_

Title \_\_\_\_\_

Subscribed and sworn to before me this \_\_\_\_\_ day of \_\_\_\_\_

Notary Public: \_\_\_\_\_

My Commission Expires: \_\_\_\_\_

**SCHEDULE OF VALUES**

**PALM SUBDIVISION UNIT NO. 2 CONTRACT NO.: C-CAP-17-186-08-08**

Item Code		Item Description	Unit	3C1080834	Orange Drive (N - S)	Palm Subd. Unit No. 2	Orange Drive (E - W)	3C1080834
100		Preparing ROW	STA					
247		8" Flex Base (Compl In Place) (TY E, GR4)	SY	7.96	6.05	14.01	\$120.00	\$1,681.20
251		Reworking BS Matl. (DC)(TY D 6")	SY	3,093	1883	4976.00	\$5.00	\$24,880.00
310		ASPH Matrl (MC-30)	GAL	3,093	1883	4976.00	\$2.00	\$9,952.00
340		D-GR HMA(SQ) TY-D SAC-B PG 64-22 (1 1/2")	SY	619	377	996.00	\$8.00	\$7,968.00
502		Barricades, Signs and Traffic Handling	MO	2,682	1614	4296.00	\$8.50	\$36,516.00
530		Turnouts (ASPH-CONC-PAV)(PB-2)	SY	2.0	2.0	4.00	\$500.00	\$2,000.00
530		Driveway (ASPH-CON-PAV)(PB-1)	SY	30	30	60.00	\$27.00	\$1,620.00
530		Driveway (Concrete 3000 PSI)	SY	108	31	139.00	\$27.00	\$3,753.00
		<b>PAVING SUBTOTAL</b>		522	31	563.00	\$36.50	\$20,184.50
<b>DRAINAGE</b>								
464		15" HPP Culvert Pipe	LF	588	60	648.00	\$25.00	\$16,200.00
464		18" RC Culvert Pipe	LF	0	70	70.00	\$35.00	\$2,450.00
464		Safety End Treatment (18")	EA	0	2	2.00	\$800.00	\$1,600.00
506		Temporary Sediment Control Fence	LF	140	20	160.00	\$3.00	\$480.00
506		Temporary Sediment Control Fence (Remove)	LF	140	20	160.00	\$2.00	\$320.00
		<b>DRAINAGE SUBTOTAL</b>						
		<b>TOTAL ESTIMATE</b>		<b>\$89,534.20</b>	<b>\$36,020.50</b>			<b>\$129,604.70</b>





Contractor Name \_\_\_\_\_  
 Starting Date \_\_\_\_\_  
 Project Ending Date \_\_\_\_\_  
 Engineers / County Project Description \_\_\_\_\_

Application No. \_\_\_\_\_  
 Application Date \_\_\_\_\_  
 Period To: \_\_\_\_\_  
 Engineers / County Project No. \_\_\_\_\_

No.	Item Code	Description	Unit	Original Schedule Value		Revised Rates	Value		First Month		Second Month		Third Month		Balance To Finish		
				Quan	Dollars		Quan	Dollars	Monthly Quan	QTY to Date	Item Cost (Monthly)	Monthly Quan	QTY to Date	Item Cost (Monthly)	Monthly Quan	QTY to Date	Item Cost (Monthly)
<b>(905) ROADWAY</b>																	
1	100	Preparation of Right-of-Way	Sq	0.0	-	-	0.0	-	0	0	0	0	-	-	-	0.0	0.0
2	152	6" road Grader Work(Dens Cont.) Subgrade	S.Y.	0.0	-	-	0.0	-	0	0	0	0	-	-	-	0.0	0.0
3	247	6" FL BS(Compl in Plac)	S.Y.	0.0	-	-	0.0	-	0	0	0	0	-	-	-	0.0	0.0
4	310	Asph. Matr. (MC-30)	Gal	0.0	-	-	0.0	-	0	0	0	0	-	-	-	0.0	0.0
5	340	Asph. Conc. T y D	S.Y.	0.0	-	-	0.0	-	0	0	0	0	-	-	-	0.0	0.0
6	500	Mobilization	L.S.	0.0	-	-	0.0	-	0	0	0	0	-	-	-	0.0	0.0
7	502	Barricades, Signs and Traffic Handling	Mo	0.0	-	-	0.0	-	0	0	0	0	-	-	-	0.0	0.0
8	530	Turnouts	Ea	0.0	-	-	0.0	-	0	0	0	0	-	-	-	0.0	0.0
9	5249	Tem Sedmt Cont Fence (Installed)	L.F.	0.0	-	-	0.0	-	0	0	0	0	-	-	-	0.0	0.0
10	5249	Tem Sedmt Cont Fence Handling (Removed)	L.F.	0.0	-	-	0.0	-	0	0	0	0	-	-	-	0.0	0.0
<b>Total Roadway</b>																	
<b>(905) DRAINAGE</b>																	
11	530	Drwy's (Asph Conc Pav)(PRB)	S.Y.	0.0	-	-	0.0	-	0	0	0	0	-	-	-	0.0	0.0
12	247	Drwy's Flexible Base	S.Y.	0.0	-	-	0.0	-	0	0	0	0	-	-	-	0.0	0.0
13	556	8" Storm Drain	L.F.	0.0	-	-	0.0	-	0	0	0	0	-	-	-	0.0	0.0
14	556	18" RCP Storm Drain	L.F.	0.0	-	-	0.0	-	0	0	0	0	-	-	-	0.0	0.0
15	465	Ty 'A' Inlets	Ea.	0.0	-	-	0.0	-	0	0	0	0	-	-	-	0.0	0.0
16	465	Concrete Manhole	Ea.	0.0	-	-	0.0	-	0	0	0	0	-	-	-	0.0	0.0
17	5249	15" R.C.P.	L.F.	0.0	-	-	0.0	-	0	0	0	0	-	-	-	0.0	0.0
18		Ty 'A' Inlets	Ea.	0.0	-	-	0.0	-	0	0	0	0	-	-	-	0.0	0.0
19		Manhole	Ea	0.0	-	-	0.0	-	0	0	0	0	-	-	-	0.0	0.0
20		6.0" Valley Gutter	L.F.	0.0	-	-	0.0	-	0	0	0	0	-	-	-	0.0	0.0
<b>Total Drainage</b>																	
<b>TOTAL BASE AMOUNTS:</b>																	

Print Name \_\_\_\_\_ Date \_\_\_\_\_

Signature \_\_\_\_\_

EXHIBIT "G"  
APPENDICES

## APPENDIX A

During the performance of this contract, the contractor, for itself, its assignees, and successors in interest (hereinafter referred to as the "contractor") agrees as follows:

1. **Compliance with Regulations:** The contractor (hereinafter includes consultants) will comply with the Acts and the Regulations relative to Nondiscrimination in Federally-assisted programs of the U.S. Department of Transportation, the Federal Highway Administration, as they may be amended from time to time, which are herein incorporated by reference and made a part of this contract.
2. **Nondiscrimination:** The contractor, with regard to the work performed by it during the contract, will not discriminate on the grounds of race, color, or national origin in the selection and retention of subcontractors, including procurements of materials and leases of equipment. The contractor will not participate directly or indirectly in the discrimination prohibited by the Acts and the Regulations, including employment practices when the contract covers any activity, project, or program set forth in Appendix B of 49 CFR Part 21.
3. **Solicitations for Subcontracts, Including Procurements of Materials and Equipment:** In all solicitations, either by competitive bidding, or negotiation made by the contractor for work to be performed under a subcontract, including procurements of materials, or leases of equipment, each potential subcontractor or supplier will be notified by the contractor of the contractor's obligations under this contract and the Acts and the Regulations relative to Nondiscrimination on the grounds of race, color, or national origin.
4. **Information and Reports:** The contractor will provide all information and reports required by the Acts, the Regulations, and directives issued pursuant thereto and will permit access to its books, records, accounts, other sources of information, and its facilities as may be determined by the Recipient or the Federal Highway Administration to be pertinent to ascertain compliance with such Acts, Regulations, and instructions. Where any information required of a contractor is in the exclusive possession of another who fails or refuses to furnish the information, the contractor will so certify to the Recipient or the Federal Highway Administration, as appropriate, and will set forth what efforts it has made to obtain the information.
5. **Sanctions for Noncompliance:** In the event of a contractor's noncompliance with the Nondiscrimination provisions of this contract, the Recipient will impose such contract sanctions as it or the Federal Highway Administration may determine to be appropriate, including, but not limited to:
  - a. withholding payments to the contractor under the contract until the contractor complies; and/or
  - b. cancelling, terminating, or suspending contract, in whole or in part.
6. **Incorporation of Provisions:** The contractor will include the provisions of paragraphs one through six in every subcontract, including procurements of materials and leases of equipment, unless exempt by the Acts, the Regulations and directives issued pursuant thereto. The contractor will take action with respect to any subcontract or procurement as the Recipient or the Federal Highway Administration may direct as a means of enforcing such provisions including sanctions for noncompliance. Provided, that if the contractor becomes involved in, or is threatened with litigation by a subcontractor, or supplier because of such direction, the contractor may request the Recipient to enter into any litigation to protect the interests of the Recipient. In addition, the contractor may request the United States to enter into the litigation to protect the interests of the United States.

## APPENDIX B

### CLAUSES FOR DEEDS TRANSFERRING UNITED STATES PROPERTY

The following clauses will be included in deeds effecting or recording the transfer of real property, structures, or improvements thereon, or granting interest therein from the United States pursuant to the provisions of Assurance 4:

NOW, THEREFORE, the U.S. Department of Transportation as authorized by law and upon the condition that the **COUNTY OF HIDALGO** will accept title to the lands and maintain the project constructed thereon in accordance with all applicable federal statutes, the Regulations for the Administration of all Department of Transportation programs, and the policies and procedures prescribed by the Federal Highway Administration of the U.S. Department of Transportation in accordance and in compliance with all requirements imposed by Title 49, Code of Federal Regulations, U.S. Department of Transportation, Subtitle A, Office of the Secretary, Part 21, Nondiscrimination in Federally-assisted programs of the U.S. Department of Transportation pertaining to and effectuating the provisions of Title VI of the Civil Rights Act of 1964 (78 Stat. 252; 42 U.S.C. § 2000d to 2000d-4), does hereby remise, release, quitclaim and convey unto the **COUNTY OF HIDALGO** all the right, title and interest of the U.S. Department of Transportation in and to said lands described in Exhibit 1 attached hereto and made a part hereof.

#### (HABENDUM CLAUSE)

TO HAVE AND TO HOLD said lands and interests therein unto **COUNTY OF HIDALGO** and its successors forever, subject, however, to the covenants, conditions, restrictions and reservations herein contained as follows, which will remain in effect for the period during which the real property or structures are used for a purpose for which Federal financial assistance is extended or for another purpose involving the provision of similar services or benefits and will be binding on the **COUNTY OF HIDALGO**, its successors and assigns.

The **COUNTY OF HIDALGO**, in consideration of the conveyance of said lands and interests in lands, does hereby covenant and agree as a covenant running with the land for itself, its successors and assigns, that (1) no person will on the grounds of race, color, or national origin, be excluded from participation in, be denied the benefits of, or be otherwise subjected to discrimination with regard to any facility located wholly or in part on, over, or under such lands hereby conveyed [,] [and]\* (2) that the **COUNTY OF HIDALGO** will use the lands and interests in lands and interests in lands so conveyed, in compliance with all requirements imposed by or pursuant to Title 49, Code of Federal Regulations, U.S. Department of Transportation, Subtitle A, Office of the Secretary, Part 21, Nondiscrimination in Federally-assisted programs of the U.S. Department of Transportation, Effectuation of Title VI of the Civil Rights Act of 1964, and as said Regulations and Acts may be amended[, and(3) that in the event of breach of any of the above-mentioned nondiscrimination conditions, the Department will have a right to enter or re-enter said lands and facilities on said land, and that above described land and facilities will thereon revert to and vest in and become the absolute property of the U.S. Department of Transportation and its assigns as such interest existed prior to this instruction].\*

(\*Reverted clause and related language to be used only when it is determined that such a clause is necessary in order to make clear the purpose of Title VI.)

## APPENDIX C

### CLAUSES FOR TRANSFER OF REAL PROPERTY ACQUIRED OR IMPROVED UNDER THE ACTIVITY, FACILITY, OR PROGRAM

The following clauses will be included in deeds, licenses, leases, permits, or similar instruments entered into by the **COUNTY OF HIDALGO** pursuant to the provisions of Assurance 7(a):

- A. The (grantee, lessee, permittee, etc. as appropriate) for himself/herself, his/her heirs, personal representatives, successors in interest, and assigns, as a part of the consideration hereof, does hereby covenant and agree [in the case of deeds and leases add "as a covenant running with the land"] that:
1. In the event facilities are constructed, maintained, or otherwise operated on the property described in this (deed, license, lease, permit, etc.) for a purpose for which a U.S. Department of Transportation activity, facility, or program is extended or for another purpose involving the provision of similar services or benefits, the (grantee, licensee, lessee, permitted, etc.) will maintain and operate such facilities and services in compliance with all requirements imposed by the Acts and Regulations (as may be amended) such that no person on the grounds of race, color, or national origin, will be excluded from participation in, denied the benefits of, or be otherwise subjected to discrimination in the use of said facilities.
- B. With respect to licenses, leases, permits, etc., in the event of breach of any of the above Nondiscrimination covenants, **COUNTY OF HIDALGO** will have the right to terminate the (lease, license, permit, etc.) and to enter, re-enter, and repossess said lands and facilities thereon, and hold the same as if the (lease, license, permit, etc.) had never been made or issued.\*
- C. With respect to a deed, in the event of breach of any of the above Nondiscrimination covenants, the **COUNTY OF HIDALGO** will have the right to enter or re-enter the lands and facilities thereon, and the above described lands and facilities will there upon revert to and vest in and become the absolute property of the **COUNTY OF HIDALGO** and its assigns.\*

(\*Reverted clause and related language to be used only when it is determined that such a clause is necessary in order to make clear the purpose of Title VI.)

## APPENDIX D

### CLAUSES FOR CONSTRUCTION/USE/ACCESS TO REAL PROPERTY ACQUIRED UNDER THE ACTIVITY, FACILITY OR PROGRAM

The following clauses will be included in deeds, licenses, permits, or similar instruments/agreements entered into by **COUNTY OF HIDALGO** pursuant to the provisions of Assurance 7(b):

- A. The (grantee, licensee, permittee, etc., as appropriate) for himself/herself, his/her heirs, personal representatives, successors in interest, and assigns, as a part of the consideration hereof, does hereby covenant and agree (in the case of deeds and leases add, "as a covenant running with the land") that (1) no person on the ground of race, color, or national origin, will be excluded from participation in, denied the benefits of, or be otherwise subjected to discrimination in the use of said facilities, (2) that in the construction of any improvements on, over, or under such land, and the furnishing of services thereon, no person on the ground of race, color, or national origin, will be excluded from participation in, denied the benefits of, or otherwise be subjected to discrimination, (3) that the (grantee, licensee, lessee, permittee, etc.) will use the premises in compliance with all other requirements imposed by or pursuant to the Acts and Regulations, as amended, set forth in this Assurance.
- B. With respect to (licenses, leases, permits, etc.), in the event of breach of any of the above Nondiscrimination covenants, **COUNTY OF HIDALGO** will have the right to terminate the (license, permit, etc., as appropriate) and to enter or re-enter and repossess said land and the facilities thereon, and hold the same as if said (license, permit, etc., as appropriate) had never been made or issued.\*
- C. With respect to deeds, in the event of breach of any of the above Nondiscrimination covenants, **COUNTY OF HIDALGO** will there upon revert to and vest in and become the absolute property of **COUNTY OF HIDALGO** and its assigns.\*

(\*Reverted clause and related language to be used only when it is determined that such a clause is necessary in order to make clear the purpose of Title VI.)

## APPENDIX E

During the performance of this contract, the contractor, for itself, its assignees, and successors in interest (hereinafter referred to as the "contractor") agrees to comply with the following nondiscrimination statutes and authorities; including but not limited to:

### **Pertinent Nondiscrimination Authorities:**

- Title VI of the Civil Rights Act of 1964 (42 U.S.C. § 2000d et seq., 78 stat. 252), (prohibits discrimination on the basis of race, color, national origin); and 49CFR Part 21.
- The Uniform Relocation Assistance and Real Property Acquisition Policies Act of 1970, (42U.S.C. § 4601), (prohibits unfair treatment of persons displaced or whose property has been acquired because of Federal or Federal-aid programs and projects);
- Federal-Aid Highway Act of 1973, (23U.S.C. § 324et seq.), (prohibits discrimination on the basis of sex);
- Section 504 of the Rehabilitation Act of 1973, (29U.S.C. § 794 et seq.), as amended, (prohibits discrimination on the basis of disability); and 49CFR Part 27;
- The Age Discrimination Act of 1975, as amended, (42U.S.C. § 6101 et seq.), (prohibits discrimination on the basis of age);
- Airport and Airway Improvement Act of 1982, (49U.S.C. § 4 71, Section 4 7123), as amended, (prohibits discrimination based on race, creed, color, national origin, or sex);
- The Civil Rights Restoration Act of 1987, (PL 100-209), (Broadened the scope, coverage and applicability of Title VI of the Civil Rights Act of 1964, The Age Discrimination Act of 1975 and Section 504 of the Rehabilitation Act of 1973, by expanding the definition of the terms "programs or activities" to include all of the programs or activities of the Federal-aid recipients, sub recipients and contractors, whether such programs or activities are Federally funded or not);
- Titles II and III of the Americans with Disabilities Act, which prohibit discrimination on the basis of disability in the operation of public entities, public and private transportation systems, places of public accommodation, and certain testing entities (42 U.S.C. §§ 12131-12189) as implemented by Department of Transportation regulations at 49C.F.R. parts 37 and 38;
- The Federal Aviation Administration's Nondiscrimination statute (49U.S.C. § 47123) (prohibits discrimination on the basis of race, color, national origin, and sex);
- Executive Order 12898, Federal Actions to Address Environmental Justice in Minority Populations and Low-Income Populations, which ensures discrimination against minority populations by discouraging programs, policies, and activities with disproportionately high and adverse human health or environmental effects on minority and low-income populations;
- Executive Order 13166, Improving Access to Services for Persons with Limited English Proficiency, and resulting agency guidance, national origin discrimination includes discrimination because of limited English proficiency (LEP). To ensure compliance with Title VI, you must take reasonable steps to ensure that LEP persons have meaningful access to your programs (70 Fed. Reg. at 74087 to 74100);
- Title IX of the Education Amendments of 1972, as amended, which prohibits you from discriminating because of sex in education programs or activities (20 U .S.C. 1681 et seq).

## **CONSTRUCTION IDENTIFICATION SIGN:**

Size, 4' - 0" X 8' - 0"

Letters to be brown with beige background

Construction Identification Signs To Be Erected Prior To Beginning of Actual Construction

Wood for Signs Shall Be  $\frac{3}{4}$ " Waterproofing Resin Bonded Exterior Grade Plywood (Douglas Fir Plywood Association of Equal)

Payment for Furnishing, Erecting, Maintenance and Removing Construction Identification Signs Will Not Be made Directly. Such Costs Shall be Included in the Overall Bid Submitted.

To Be Erected as Indicated on title Sheet.

Precinct Logo



# Your Tax Dollars at Work Hidalgo County Pct 3

Joe M. Flores, Commissioner  
Border Colonia Access Program

In Partnership with Texas Department of Transportation

## **Palm Subdivision Unit No. 2**

Hidalgo County Commissioner's Court

Ramon Garcia	-	County Judge
David L. Fuentes	-	Commissioner Pct #1
Eduardo "Eddie" Cantu	-	Commissioner Pct #2
Joe M. Flores	-	Commissioner Pct #3
Joseph Palacios	-	Commissioner Pct #4

Project Contractor: Five Star Galaxy Construction, LLC

Project Engineer: Javier Hinojosa Engineering

IN WITNESS WHEREOF, the parties to these present have executed this contract in six (6) counterparts, each of which shall be deemed an original, in year and day first above mentioned.

APPROVED BY COMMISSIONERS COURT ON, **August 8, 2017.**

CONTRACTOR: *Sorais De Hoyos*  
Print Name & Title: Sorais De Hoyos, Managing Member  
Name of Firm: Five Star Galaxy Construction, LLC  
Address: 4012 S. Cesar Chavez Road  
San Juan, Texas 78589  
Fed I.D. #/SS #: 47-3551092

STATE OF TEXAS  
COUNTY OF HIDALGO

This instrument was acknowledged before me on this the 11<sup>th</sup> day of Aug,  
2017, by Sorais De Hoyos, Managing Member of and on behalf of Five Star Galaxy Construction, LLC.  
(Name) (Title) (A corporation)

*Krista Garcia*  
Notary Public-Signature

APPROVED AS TO FORM:



BY: *A. Th*  
Assistant D.A.

DATE: 9-15-2017

ATTEST:

COUNTY OF HIDALGO:

*Arturo Guajardo*  
Arturo Guajardo, County Clerk

*Ramon Garcia*  
Ramon Garcia, County Judge

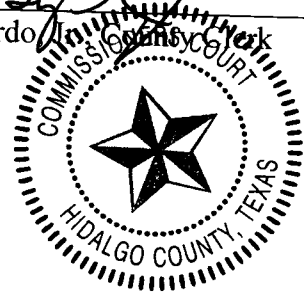

APPROVED BY  
COMMISSIONERS' COURT  
ON: 9/26/17 *JK*