

A. Hidalgo County

1. **AI-88417** A. Requesting approval of the following Change Order in connection with the construction of the Hidalgo County Courthouse from the contracted vendor, Morganti Texas, Inc.;

<u>Description</u>	<u>Total Amount</u>
Change Order MTI - 86 Installation of fire smoke dampers	(not to exceed) \$105,997.00

B. Requesting authority for County Judge and/or Valde Guerra, Executive Officer to sign required documents.

(Audio Reference 1h:32m 12s)

On motion by COMMISSIONER PCT. 2, EDUARDO "EDDIE" CANTU, seconded by COMMISSIONER PCT. 1, DAVID FUENTES, the Court made a UNANIMOUS vote of approval on agenda items 23.A.1.A and 23.A.1.B.

Vote: 5 - 0 -Unanimously

Attachments:

1295

1295

MTI-86

**CHANGE
ORDER**

**OWNER
ARCHITECT
CONTRACTOR**

Karina Esparza

E-signed 2023-01-20 11:44AM CST

karina.esparza@co.hidalgo.tx.us



X
X
X

PROJECT: Hidalgo County Courthouse
Project 1830.007

CONTRACTORS CHANGE ORDER #: MTI 86
DATE: November 10th, 2022
CONTRACT DATE: March 27th, 2018

To County of Hidalgo, Texas:

This Change Order MTI-86 is entered into by and between Owner and Contractor for the purpose of commencing with the Price for additional services as listed below. All items will be fully funded based on the prices below.

The workorder is changed as follows per approved estimate for additional scope:

			RFI 638 and 638.1 Added Smoke Dampers-5	88,356

Total Amount for Change Order

\$ 88,356

Not valid until signed by the Owner and Contractor.

The original (GMP Contract)	\$ 515,065
Early Site/Foundation/Underground Utility Package (GMP AMENDMENT NO.1)	\$ 8,950,855
The 50% CD 100% Structural GMP Package (GMP AMENDMENT NO.2)	\$ 118,410,191
Amendment 3 GMP 100% CD	\$ 4,195,867
Net change by previously authorized Change Orders - Original	\$ 2,482,986
GMP Contract will be Increased by this Change Order in the amount of	\$88,356
Transfer from Original Scope to Added Scope	(\$ 772,726.12)
Transfer from Original Scope to Design Contingency	\$0
Transfer from Original Scope to Design Contingency	(\$ 75,454)
Transfer from Original Scope to Design Contingency Allowance Balance	(\$ 136,648)
Contract GMP including this Change Order, previously approve Change Orders and Amendments	\$ 133,658,491.88
Added Scope Amendment for CPR 14	\$ 10,481,134
Added Scope Amendment for CPR 57.2	\$ 3,565,310
Added Scope Net change by previously authorized Change Orders	\$ 957,401
The (GMP Contract) will be Increased by this Change Order in the amount of	\$0.00
Transfer from Original Scope to Added Scope	\$ 772,726.12
Transfer from Original Scope to Design Contingency	0
Transfer from Original Scope to Design Contingency	\$ 75,454
Transfer from Original Scope to Design Contingency Allowance Balance	\$136,648
Added Scope Value including this Change Order & GMP Amendments will be	\$ 15,988,673.12
Total Contract GMP	\$ 149,647,165.00
The Contract Time for this Change Order will be increased by	

The Original date of Substantial Completion	February 28, 2021
The Current Date of Substantial Completion	August 27th, 2022

PROJECT: Hidalgo County Courthouse
Project 1830.007

CONTRACTORS CHANGE ORDER #: MTI-86
DATE: November 10th, 2022
CONTRACT DATE: March 27th, 2018

Signature Page:

**This additional scope will increase the contract duration by 42 Days.
Change Order Request came after August 27th, 2022 substantial completion date.
New Substantial completion date to be determined upon approval.**

Contractor:

Morganti Texas, Inc.
10590 West Office Dr. Ste 150
Houston, Tx 77042

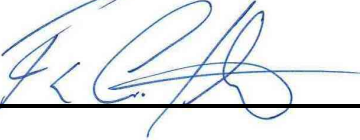

Architect:

HDR Architecture, Inc.
8750 N. Central Expressway
Dallas, Texas 75231

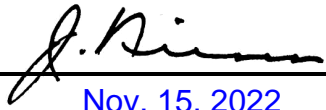

_____ Nov. 15, 2022

Owner:

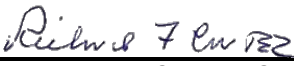
County of Hidalgo, Texas
2812 S. Business 281
Edinburg, TX 78539

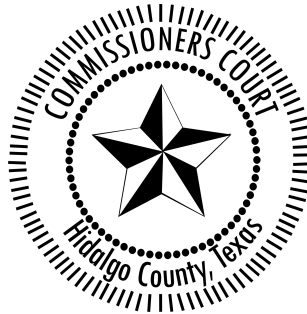

Richard F. Cortez, County Judge





Arturo Guajardo, Jr., County Clerk

EXECUTED as of the day and year first written above.

APPROVED BY COMMISSIONERS' COURT ON NOVEMBER 15, 2022.

Agenda Item No. 88417

Executive Office: 
MS

VENDOR:
MORGANTI TEXAS, INC.

COUNTY:
COUNTY OF HIDALGO

Frank Gotham (Jan 19, 2022 11:06 CST)
Frank Gotham, Regional Director of Operations

Hon. Richard F. Cortez, County Judge

ATTEST:



Arturo Guajardo, Jr., County Clerk

ATTACHMENTS:
Change Order Documents

SUPPLEMENTAL SIGNATURES:

ARCHITECT:
HDR ARCHITECTURE, INC.

John Niesen, Architect

November 10, 2022

Jacobs

RFI 638 and 638.1 Added Smoke Dampers-5

Dear Mr. Garcia,

Listed below is the additional scope of work along with associated labor and materials to complete the work.

Description	Amount
This proposal is for the installation of fire smoke dampers. This includes labor and materials.	\$ 82,176.57
<hr/>	
Clarifications:	Sub-Total \$ 82,177
Refer to Sheet: N/A	Bond \$ 822
	Builder's Risk \$ 255
	CCIP \$ 1,372
	SDI \$ 1,266
	Permit
	Fee \$ 2,465
	Sales Tax
	Total \$ 88,356

**This additional scope will increase the contract duration by 42 Days.
 Change Order Request came after August 27th, 2022 substantial completion date.
 New Substantial completion date to be determined upon approval.**

This proposal will expire 15 days from date of original submission.
 Any delay in approval will result in project delays & additional costs.

Sincerely,

Frank Gotham

By signing this proposal, I agree to the change in scope and contract amount.

By: _____ Date: _____

Jacobs

BASE BID TABULATION

PROJECT: Hidalgo County Courthouse

Run:

Spec	Description	Opt.	Sub/Notes	
010000	General Conditions		General Conditions	\$ 50,427.00
010000	Pre Construction Services			\$ -
010001	General Requirements			\$ -
400005	BUILDING PERMIT CITY OF EDINBURG	1	1=Reqd 2=Exclude	\$ -
TOTAL GEN CONDITIONS				\$ 50,427.00
020000	EXISTING CONDITIONS/GENERAL REQUIREMENTS/DEMO			
029999	MONUMENT SALVAGE ALLOWANCE		w/ ESP	\$ -
029999	CAST STONE MASONRY			\$ -
029999	Man/ Material hoist		MTI	\$ -
029999	Daily Clean		MTI	\$ -
029999	Dust Control		MTI	\$ -
029999	TEMP PROTECTION (MOVE FALL PROTECTION)		MTI	\$ -
029999	SITE MAINTENANCE & SAFETY		MTI	\$ -
TOTAL EXISTING CONDITIONS				\$ -
090000	FINISHES			
092300	GYPSUM PLASTER		Marek	\$ 660.00
099123	PAINTING		Paint X-Perts	\$ 369.60
TOTAL FINISHES				\$ 1,029.60
210000	FIRE SUPPPRESSION			
211000	FIRE Suppression SYSTEMS		Fire Systems of TX	\$ 463.97
TOTAL FIRE SUPPRESSION				\$ 463.97
230000	HVAC			
232113	FIRE DAMPERS		Victoria Air Con	\$ 19,389.00
TOTAL HVAC				\$ 19,389.00
260000	ELECTRICAL			
260000	ELECTRICAL PACKAGE 2		w/ 260010	\$ 4,574.00
TOTAL ELECTRICAL				\$ 4,574.00
280000	SAFETY AND SECURITY			
283100	FIRE ALARM SYSTEM		Telepro	\$ 4,951.00
283100	FIRE ALARM SYSTEM		Telepro	\$ 1,342.00
TOTAL SAFETY AND SECURITY				\$ 6,293.00
TOTAL				\$ 82,176.57



200 S. Ben Jordan
P.O. Box 3882
Victoria, TX 77901
(361) 578-5241 Fax
576-0811

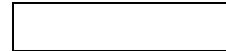

Date: 11/2/2022

Attn: **Macon Macicek**

Re: **44275 Hidalgo County Courthouse – Clean Agent Change**

COR-0059 rev3

Ladies & Gentlemen:

We have reviewed the requirements of the above referenced documents as they pertain to our contract. In compliance with the terms of our subcontract agreement, we agree to perform the changed work: \$19,389.00.

15 Calendar days from the date of this letter our price will expire.

Included in our price is the following: Provide and install smoke dampers and communication wiring pursuant to the attached breakdowns.

The current lead time for the fire smoke dampers is 6 weeks and subject to change without notice.

57 days extension of contract time is required for damper procurement (6 weeks) and installation 15 days.

- Standard conditions on page two of this form apply.
- Excludes any work not specifically listed in the attached breakdown
- Excludes repair or replacement of “in place” work damaged during the execution of this change
- Excludes cutting, patching and framing of sheetrock or ceiling systems
- Excludes 120 volt wiring

Please respond to the above referenced Change Order Request number when responding to this

Quotation.

Respectfully Submitted,

Ken Hasbrouck
Sr. Project Manager

cc: John Hickman-VAC

STANDARD CONDITIONS:

1. The payment requested in this change estimate does not include any amounts for changes in sequence of work, delays, disruptions, or impact costs due to the accumulative effect of this change with other changes or any other reason and our rights are expressly reserved to make claim for any and all of these related items or costs prior to final payment upon this contract.
2. The work presented in this proposal is consistent with Victoria Air Conditioning, LTD's base contract scope of work. Any terms conditions, exclusions and clarifications of the base scope of work. Any terms conditions, exclusions and clarifications of the base estimate cost detail.
3. Changes proceeded upon by Victoria Air Conditioning, LTD's at the direction of General Contractor, Construction Manager or the Owner shall be immediately billable to 50% on commencement of the work.
4. Progress payments delayed for work contained in this proposal, caused through no fault of Victoria Air Conditioning, LTD's, or may cause suspension of the work.
5. This proposal is predicated on the logical implementation of the added work into the Project Construction Schedule. Unless designated otherwise, this proposal is based on installation performance at an optimum, productive and uninterrupted manner.
6. We do NOT include in this change estimate any costs for removing, replacing or alteration to NON-mechanical/electrical work required of other trades unless specifically designated in the change estimate cost detail. We reserve the right to reassess the impact of any NON- mechanical/electrical drawing revisions or supplement should the effects thereof not be reflected on a future mechanical/electrical drawing or specification revision, or change request presentation.
7. We do not include in this change estimate any costs for work mandated by construction procedures implemented by other trades unless specifically designated in the change estimate cost detail.
8. In the advent that this change delays the completion and acceptance of the Project, associated delay, cost, inclusive of extended overhead costs, Retention finance costs, etc., are specifically NOT included in this change estimate proposal.
9. Should the words 'engineering' appear in this proposal, Victoria Air Conditioning, LTD specifically excludes any and all liabilities, including adequacy of design or time impacts, related thereto, unless specifically designated otherwise in the same contract AND the change estimate cost details.
10. This estimate excludes all costs related to Asbestos Abatement, Asbestos Safety Apparatus and Procedures, or Hazardous Substance Abatement unless specifically designated in the change estimate details.

Victoria Air Conditioning, Ltd. is not responsible for the consequences of design defects in and may not warranty the accuracy, adequacy, sufficiency, or suitability of the plans, specifications, or other design documents provided to Victoria Air Conditioning, Ltd. by a person other than the Victoria Air Conditioning, Ltd.'s agents, contractors, fabricators, or suppliers, or its consultants, of any tier.

Time and Material (T&M) Hourly Rates:			T&M Vendor & Sub Mark Up Rates:	
Crew Size-worker	REG	OT	Value	%
T&M 1w Crew	\$144.00	\$216.00	Less than \$10K	30%
T&M 2w Crew	\$216.00	\$324.00	Less than \$100K-\$10k	25%
T&M 3w Crew	\$288.00	\$432.00	Over \$100K	20%

COST ANALYSIS WORKSHEET

Project Name and No. Hidalgo County Courthouse 44275 **Date:** 11/2/2022

CHANGE DESCRIPTION VAC COR-059r3 Add Smoke Dampers at Duct Serving 2A-142 for Clean Agent Add

MATERIAL and EQUIPMENT					AMOUNT
A. PLUMBING/PIPING EQUIPMENT					
B. HVAC EQUIPMENT					\$3,941.40
C. SHEET METAL MATERIAL					\$0.00
D. PLUMBING/PIPING MATERIAL					\$0.00
E. MISCELLANEOUS MATERIALS (A, B, C, D)	\$3,941.40	X	15.00%	=	\$591.21
F. SALES TAX ON MATERIALS (A, B, C, D, E)	8.25%	X	0.00%	=	\$0.00

Review Contract to Confirm if Sales Tax is Required. New Construction-This line N/A on Remodel Project

LABOR (includes burden)					
G. TECHNICIAN	12.00	HRS X \$	85.00	=	\$1,020.00
H. PIPEFITTER	0.00	HRS X \$	44.57	=	\$0.00
I. DUCT	66.51	HRS X \$	45.60	=	\$3,032.86
J. LABOR	0.00	HRS X \$	24.42	=	\$0.00
K. CREW FOREMAN/SUPERINTENDENT	7.00	HRS X \$	65.00	=	\$455.00

MISCELLANEOUS					
L. FUEL COST					
M. RENTALS					
N. FREIGHT/DRAYAGE					\$0.00
O. O&M MANUALS/AS-BUILT DRAWINGS (A, B)	0.00	X	2.00%	=	\$0.00
P. WARRANTY RESERVE (A, B, C, D)	3,941.40	X	5.00%	=	\$197.07
Q. IDENTIFICATION & PAINTING					\$33.00
R. DRAFTING	0.00	HRS X \$	95.00	=	\$0.00
S. TESTING (G, H, I, J)	4,052.86	X	6.00%	=	\$243.17
T. STORAGE COSTS					
U. DIRECT PROJECT MANAGEMENT COSTS					\$1,200.00
V.					
W.					\$0.00
X.					\$0.00
Victoria Air Conditioning Subtotal					\$10,713.71
Bond for VAC subtotal	\$10,713.71	X	0.00%	=	\$0.00
Liability/Umbrella Insurance	\$10,713.71	X	0.00%	=	\$0.00
Overhead & Profit	\$10,713.71	X	10.00%	=	\$1,071.37
VICTORIA AIR CONDITIONING TOTAL					\$11,785.08

SUBCONTRACT WORK

1. Insulation	\$	2,135.00				
2. JCI	\$	4,440.00				
3. PHI	\$					
Subtotal Subcontract					\$6,575.00	
Bond for Subcontract subtotals	6,575.00	X	0.00%	=	\$0.00	
Liability/Umbrella Insurance	6,575.00	X	0.00%	=	\$0.00	
Overhead & Profit	6,575.00	X	5.00%	=	\$328.75	
PROJECT CHANGE TOTAL					\$18,689	
Sales Tax on Project for Remodel/Additions	8.25%	\$18,688.83	X	0.00%	=	\$0.00

This Sales Tax Line N/A on New Construction

TOTAL CHANGE ORDER PRICE IF ACCEPTED WITHOUT NEGOTIATION	\$18,689
Negotiation Time Fee per HR	\$350.00
2 HRS	\$700.00
TOTAL CHANGE ORDER PRICE	\$19,389

TIME: This C.P. will require 15 additional working days to the contract and the affected milestones.

ATTACHMENT "E"

Labor Code 401
Sheet Metal Ductwork

Total Mat Cost **\$ 3,941.40**

Total Labor Hrs **66.51**

QTY	Size	Discription	Unit	MTL Unit	MTL Ext	Material Cost		LBR Ext
						Code	LBR Unit	
3	all	Demo Insulation	ea	\$ -	\$ -		2.210	6.630
2	all	Cut / Prep duct	ea	\$ -	\$ -		2.210	4.420
3	all	Install Smoke Dampers	ea	\$ 1,183.75	\$ 3,551.25	435	5.700	17.100
1	24 x 24	Sheetrock access door	ea	\$ 390.15	\$ 390.15	445	3.900	3.900
1.00	all	Re-inspect area prior to revision 2	ea				4.000	4.000
36.05		O/T correction 50 hr week	hr	\$ -	\$ -		0.110	3.966
36.05		unload/material handling/mob	hr	\$ -	\$ -		0.250	9.013
36.05		Congested Area/out of sequence	hr	\$ -	\$ -		0.200	7.210
36.05		Dilution of Supervision	hr	\$ -	\$ -		0.110	3.966
36.05		Covid Labor Impact	hr	\$ -	\$ -		0.175	6.309
				\$ -	\$ -		-	-



PO BOX 2020 MISSION, TX 78573 PH:(956)519-7872 FX: (956)519-9851

www.insul-nation.com

CHANGE PROPOSAL

Name: Victoria Air Conditioning, LTD

Date: 04/06/2022

PROJECT: 44275 HCCH Smoke Damper Add

ITEM	DESCRIPTION	AMOUNT	
1	Smoke Damper Add	548.05	
	<ul style="list-style-type: none"> • (1) 42x12 • (2) 14" supply duct round @278.20 each 	628.73	
	Includes new ductwrap rolls, Aluminum Tape & Mastic		
	Labor & Insurances	763.60	
		SUBTOTAL	1,940.38
		PROFIT	194.04
		TOTAL	\$2,134.42
Thank You For Your Business! God Bless			

BID DATE: 11/01/22

REVISION: No Plans and Specs Provided

TO: Victoria AC - Ken

LAST ADDENDUM: NA

PROJECT: Hidalgo County Change Order RFI # 638

Proposal

We are pleased to provide pricing for the JOHNSON CONTROLS BAS EQUIPMENT for the above referenced project.



DESCRIPTION: JOHNSON CONTROLS METASYS BUILDING AUTOMATION SYSTEM ADDITION/EXPANSION:

- Metasys Facility Management System Summary: Hidalgo County Courthouse
 - Technician Time to transfer and wire CRAC systems Qty(2) to Clean Agent system
 - Upgrade dynamics graphics package to reflect change order as described
 - Standard one-year warranty
- Install Labor-\$2,220.00, Material- \$420.00 Tech Labor: \$1,800.00

NOTES / EXCLUSIONS:

- Any Existing mechanical work and/or Mechanical Dampers are **excluded**
- Smoke Detectors are **excluded** on this proposal, to be provided by others
- Fire and Smoke Dampers and Actuators are **excluded** to be provided by others
- Fire Alarm interlocks are **excluded** (by FA)
- Fire Fighters Control Panel **excluded**
- Line voltage power to any equipment and/ or Security Systems & Components **excluded**
- Lighting Systems & components are **excluded**
- Any Items, or work not specifically listed or described above, is to be **excluded** from this proposal.
- Test & balance is **excluded and/or** provided by others

Base Price (No Taxes included on this proposal) ----- \$ 4,440.00

Price good for 30 days from quote date.

Clean Agent ADD

VAC Scope of Work

	Location	Scope
	2A-143 – CRAC 2-1 and CRAC 2-2	JCI Shutdown Control wiring installation from CRAC to Clean Agent Shutdown Relay
	2A-143 S/A Duct	Cut S/A duct and install Smoke Dampers (Damper 120 volt by others)
	2A-143 R/A Duct	Remove R/A Grille, Remove Balance Damper and Install Smoke Damper
		Damper Wiring and Control By Others
	2A-143	Re-insulate S/A and R/A Duct
		All 120 volt wiring excluded

MAN. CLOSET /
STOR

12X12 D
800 CFM

CRAC-2-1

MDF

Smoke Damper and
Ceiling Access Door

2A-143

PER RFI 140
2A-141

18ø33

24

TOD=12'-0"
BOD=10'-6"

9'-0"

STAF
LACTAT

TOD=11'-10"
BOD=10'-8"

Smoke Damper

CRAC-2-2

12X12 D
800 CFM

6ø A
50 CFM

9'-0"

RH

Remove BD and
Install Smoke Damper

42X12 J
1600 CFM

42x12

TOD=12'-10"
BOD=10'-8"

EXH DUCT UNDER
RA DUCT

D=10'-4"
D=9'-6"

50x26 48

50x26 56

50x26 56

OFF-6

SUBMITTAL PACKAGE

Smoke Dampers

Model: SD60 - Galvanized Steel Airfoil Blade

ID#	Qty	Width (A)	Height (B)	Diameter (D)	Size	Frame	Actuator Type	Assembly Temp	Velocity (FPM)	Static Pressure (in. w.g.)
SD60-1	2			14	Deduct 1/4	CR STYLE	120 VOLT W/SWITCH	250 DEGREE	2000 FPM	4 INCHES
SD60-2	1	42	12		Deduct 1/4	A STYLE	120 VOLT W/SWITCH	250 DEGREE	2000 FPM	4 INCHES

Note:

- Quantities and Sizes listed are for submittal purposes only, to be verified prior to order.
- Submittal information is deemed correct at time of printing, however in the interest of product improvement Ruskin reserves the right to make changes without notice.

SD60

Galvanized Steel Airfoil Blade
UL555S Leakage Class 1



CONSTRUCTION

PERFORMANCE RATINGS

Frame	5" x 16 gauge galvanized, single piece, hat-shaped channel
Blades	One-piece airfoil, nominal 6" wide galvanized steel
Bearings	Stainless Steel Sleeve Type
Jamb Seals	Stainless steel, flexible metal compression type
Blade Seals	Silicone Edge Seal
Frame Style	CR STYLE
Blade Action	OPPOSED
Linkage Matl	STANDARD
Fail Position	CLOSE
Wiring Connection	STANDARD
Damper Interface	NA
Side Plate	NO
Slv/Tran	SLEEVE
Slv/Tran Mat	GALVANIZED
Hole Pattern	NO HOLES

Velocity	2000 FPM
Static Pressure	4 INCHES
Assembly Temperature	250 DEGREE
Airflow	Both Directions
CSFM Listing	3230-0245:0131
Canadian Listing	S112

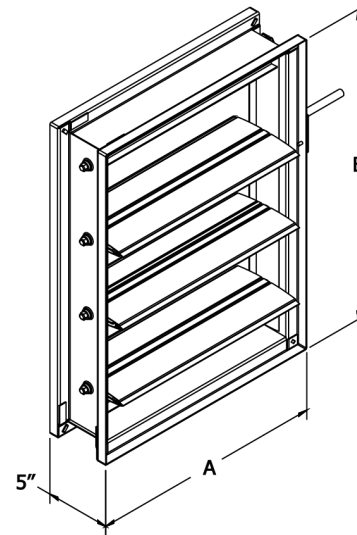

ACTUATOR DETAILS

Actuator Type	120 VOLT W/SWITCH
Fail Position	CLOSE
Installation	OUT



SCHEDULE

ID#	Qty	Dimensions (Inches)		Blade Action	Sections		Actuator		Actuator			Sleeve	
		Diameter	Size		Wide	High	Type	Model	Fail Pos	Installation	Qty	Length (L)	Gauge
SD60-1	2	14	Deduct 1/4	OPPOSED	1	1	120 VOLT W/SWITCH	FSLF120S	CLOSE	OUT	1	16	20 Gauge

SD60

Galvanized Steel Airfoil Blade
UL555S Leakage Class 1



CONSTRUCTION

Frame	5" x 16 gauge galvanized, single piece, hat-shaped channel
Blades	One-piece airfoil, nominal 6" wide galvanized steel
Bearings	Stainless Steel Sleeve Type
Jamb Seals	Stainless steel, flexible metal compression type
Blade Seals	Silicone Edge Seal
Frame Style	A STYLE
Blade Action	OPPOSED
Linkage Matl	STANDARD
Fail Position	CLOSE
Wiring Connection	STANDARD
Damper Interface	NA
Side Plate	YES
Hole Pattern	NO HOLES

PERFORMANCE RATINGS

Velocity	2000 FPM
Static Pressure	4 INCHES
Assembly Temperature	250 DEGREE
Airflow	Both Directions
CSFM Listing	3230-0245:0131
Canadian Listing	S112

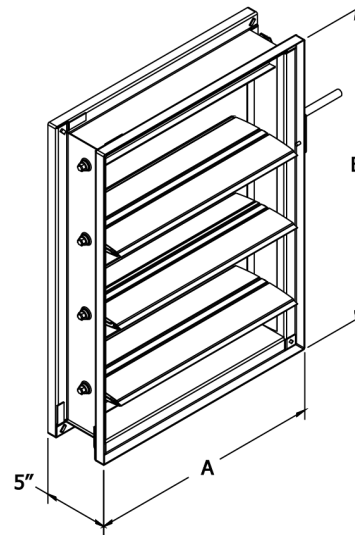

ACTUATOR DETAILS

Actuator Type	120 VOLT W/SWITCH
Fail Position	CLOSE
Installation	OUT



SCHEDULE

ID#	Qty	Dimensions (Inches)			Blade Action	Sections		Actuator		Actuator		
		Width (A)	Height (B)	Size		Wide	High	Type	Model	Fail Pos	Installation	Qty
SD60-2	1	42	12	Deduct 1/4	OPPOSED	1	1	120 VOLT W/SWITCH	FSNF120S	CLOSE	OUT	1

Norma Salinas

From: Macon Macicek
Sent: Monday, October 3, 2022 9:15 AM
To: Norma Salinas
Subject: FW: 44275 RE: HCCH - RFI 638, 638.1 and 638.2 Added Smoke Dampers-4
Attachments: image006.jpg

Use this email as backup for quick ship add.



www.morganti.com



MACON MACICEK

SENIOR PROJECT MANAGER

DIRECT: +1.281.661.4487
MAIN: +1.281.448.1015
CELL: +1.832.654.3285
EMAIL: mmacicek@morganti.com

MORGANTI TEXAS, INC.
10590 West Office Drive, Suite 150
Houston, Texas 77042

CT • NY • FL • TX • INT'L

AFFIRMATIVE ACTION/EQUAL OPPORTUNITY EMPLOYER

From: Macon Macicek
Sent: Friday, September 30, 2022 4:09 PM
To: Garcia, Oscar <Oscar.Garcia@jacobs.com>
Cc: Pete Peters <ppeters@morganti.com>
Subject: FW: 44275 RE: HCCH - RFI 638, 638.1 and 638.2 Added Smoke Dampers-4

Does the owner want to expedite these dampers? This is a cost that is associated with RFI 638, 638.1 and 638.2 that will be submitted to Jacobs for approval as a design add.



www.morganti.com



MACON MACICEK

SENIOR PROJECT MANAGER

DIRECT: +1.281.661.4487
MAIN: +1.281.448.1015
CELL: +1.832.654.3285
EMAIL: mmacicek@morganti.com

MORGANTI TEXAS, INC.
10590 West Office Drive, Suite 150
Houston, Texas 77042

CT • NY • FL • TX • INT'L

AFFIRMATIVE ACTION/EQUAL OPPORTUNITY EMPLOYER

|

From: Ken Hasbrouck <KenHasbrouck@victoriaair.com>
Sent: Friday, September 30, 2022 2:26 PM
To: Pete Peters <ppeters@morganti.com>; Macon Macicek <mmacicek@morganti.com>
Cc: Frank Gotham <fgotham@morganti.com>; Gilbert Flores <Gilbertflores@victoriaair.com>; John Hickman <JohnHickman@victoriaair.com>; Daniel Gutierrez <dgutierrez@morganti.com>; Dustin Enderle <denderle@morganti.com>; Fontunato Garcia <fgarcia@morganti.com>; Ken Hasbrouck <KenHasbrouck@victoriaair.com>
Subject: RE: 44275 RE: HCCH - RFI 638, 638.1 and 638.2 Added Smoke Dampers-4

Macon,

The factory has a quick ship option on the dampers that “should” get the dampers to the site within 15 days of release. The cost is an additional \$1,242.00.

They do not guarantee the time frame but historically are within a couple of days of the 15 days. The normal lead time is 5 to 6 weeks – also not guaranteed.

Ken Hasbrouck
Sr. Project Manager
Victoria Air Conditioning, LTD.
(956) 341-4471 Cell
(361) 578-1929 Fax
kenhasbrouck@victoriaair.com

From: Pete Peters <ppeters@morganti.com>
Sent: Friday, September 30, 2022 2:05 PM
To: Ken Hasbrouck <KenHasbrouck@victoriaair.com>; Macon Macicek <mmacicek@morganti.com>; Stewart Gregorie <stewart.gregorie@metroelectric-rgv.com>
Cc: Frank Gotham <fgotham@morganti.com>; Gilbert Flores <Gilbertflores@victoriaair.com>; John Hickman <JohnHickman@victoriaair.com>; daniel.alvarez@jci.com; Daniel Gutierrez <dgutierrez@morganti.com>; Dustin Enderle <denderle@morganti.com>; Fontunato Garcia <fgarcia@morganti.com>
Subject: 44275 RE: HCCH - RFI 638, 638.1 and 638.2 Added Smoke Dampers-4

CAUTION: External Email.

Macon,

Deadline is yesterday.



www.morganti.com



PETE PETERS
GENERAL SUPERINTENDENT

CELL: 607-279-1566
EMAIL: ppeters@morganti.com

10590 Westoffice Drive, Suite 150
Houston, Texas 77042

CT • NY • FL • TX • INT'L

AFFIRMATIVE ACTION/EQUAL OPPORTUNITY EMPLOYER

company accepts no liability for any damage caused by any virus transmitted by this email.'



Project Name Hidalgo County Courthouse
Project Number 1253NW
Address 100 N Closner Blvd
City Edinburg

Subcontractor Fire Systems of Texas, LLC.
Phone # 956-391-1191

Change Date 9/29/2022
Change Number CO19
Change Reference 0
Change Description Connecting Damper wires provided by other to the relay contacts in the suppression control panel and reprogramming panel for damper activations upon alarm.

Labor Totals	
Base Labor Cost	\$ -
Fringe Benefits	\$ -
Taxes & Insurance	\$ -
Labor Total	\$ -

Material Totals	
Base Material Costs	\$ 354.75
Sales Tax	\$ -
Delivery	\$ 31.89
Material Total	\$ 386.64

Change Totals	
Labor Total	\$ -
Material Total	\$ 386.64
Subtotal	\$ 386.64

Overhead	10%	\$ 38.66
Profit	10%	\$ 38.66
Change Total		\$ 463.97

Quantity	Units	Size	Material Group	Description	Unit Material	Extended Material	Labor Hours	Total Hours	Unit Labor	Extended Labor	Unit Equipment	Extended Equipment	Extended Total
1			Labor	Connecting Damper	\$ 354.75	\$ 354.75		0	\$ -	\$ -	\$ -	\$ -	\$ 354.75
Subtotal													\$ 354.75

Project Name	Hidalgo County Courthouse
CO Number	CO19



March 2, 2022

ROBERT GONZALEZ
MORGANTI TEXAS, INC
10590 WESTOFFICE DR, STE 150
HOUSTON, TX 77042

Re: HIDALGO CTY NEW COURTHOUSE
Bid # Q04025

CHANGE ORDER FOR RFI #638

Dear ROBERT:

Thank you for the opportunity to submit the following proposal for the above referenced project.

Scope of Work:

FIRE ALARM SYSTEM — RFI #638

- PROVIDE AND INSTALL (3) FIRE ALARM RELAY MODULES FOR CLEAN AGENT MECH INTEGRATION
- INCLUDES CABLE, PROGRAMMING, AND TESTING

Total Price \$1,342.00

EXCLUDING THE FOLLOWING:

1. ELECTRICAL WORK, BACK BOXES, CONDUIT OR MOLDING, CONDUIT BETWEEN FIRE WALLS OR BUILDINGS, AND SLEEVES
2. ANY ADDITIONAL WORK NOT INCLUDED; IF REQUIRED BY CONTRACTOR.
3. ANY CHANGES THAT ARE MADE BY AHJ ABOVE AND BEYOND STATE NFPA CODES.
4. ANY PAINTING TO BE COMPLETED BY OTHERS.

PRICES ARE FIRM FOR 30 DAYS FROM QUOTE, WITH EXCEPTION OF COPPER AND OTHER VOLATILE COMMODITIES

* * *

I hope you find this proposal complete and to your satisfaction.

Sincerely,

Daniel Backhaus
Sr. Project Estimator

**HIDALGO COUNTY NEW COURTHOUSE
CHANGE ORDER FOR RFI #638.1 - MDF 2A-143**

QTY	DESCRIPTION	PART NO.	MANUFACTURER	UNIT PRICE	TOTAL PRICE
3	SUPER DUCT DETECTOR	SIGA-SD	EST	\$ 368.00	\$ 1,104.00
3	REMOTE TEST/RESET STATION	SD-TRK	EST	\$ 83.00	\$ 249.00
3	SAMPLE TUBES	SD-T78	EST	\$ 23.00	\$ 69.00
3	CONTROL RELAY MODULE	SIGA-CR	EST	\$ 137.00	\$ 411.00
3	SINGLE MONITOR MODULE	SIGA-CT1	EST	\$ 99.00	\$ 297.00
1	18-2 fplp -- Plenum-rated -- (from Data Optics)	8704	COMTRAN	\$ 453.00	\$ 453.00
1	18-4 fplp -- Plenum-rated -- (from Data Optics)	8705	COMTRAN	\$ 618.00	\$ 618.00
				MATERIALS SUBTOTAL	\$ 3,201.00
1	WIRING FOR DEVICES			\$ 850.00	\$ 850.00
1	DEVICE INSTALLATION			\$ 550.00	\$ 550.00
1	TESTING			\$ 150.00	\$ 150.00
1	PROGRAMMING			\$ 100.00	\$ 100.00
1	DESIGN WORK			\$ 100.00	\$ 100.00
				MATERIALS SUBTOTAL	\$ 1,750.00
				GRAND TOTAL	\$ 4,951.00



Hidalgo County Courthouse - Change Order Request

ATTN: Mr. Macon Macicek

DATE: October 12, 2022

Subject: Change Order Request

Work to be included is as follows:

- **RFI #638.1 Remove and reinstall ceiling and provide opening as needed for new smoke dampers for MDF room 2A-143**

Material:	
• N/A	
Sales Tax (8.25%)	N/A
Freight/Delivery	N/A
Equipment Rental / Gas & Oil	
Total Material/Equipment	
Labor	
Labor	\$440.00
Labor Foreman	\$160.00
Total Direct Labor	\$600.00
Subtotal	\$600.00
OH&P (10%)	\$60.00
Total Price of Change Proposal	\$660.00

Please contact me if you have any questions.

Sincerely,

Alejandro Rebeles

Project Manager/ Estimator

PAINT X PERTS COMMERCIAL COATINGS, LLC.

3210 Saturn St. Edinburg, Texas 78542

PHONE: (956) 560 2013

TO: Morgantti

Date : 11/09/2022

Contact Norma Salinas

Project: Hidalgo Court House

CHANGE ORDER # 11092022-1

RE: RFI 638 &638.1

Items	Work Description	Amount	Total
1	icnludes any tape and float involved in cutting or patching for the isntalation of fire dampers at rooms 2A 146 & 2A 143 primer & Paint as needed paint acces panel If added to matched ceiling		
	Material Amount	\$ 80,00	
	Labor Based On 8 hrs @ \$32.00	\$ 256,00	
	OH&P 10%	\$ 33,60	
			\$369,60
			\$ -
	SUBTOTAL		\$ 369,60
	TAX	8,25%	\$ -
	TOTAL		\$ 369,60

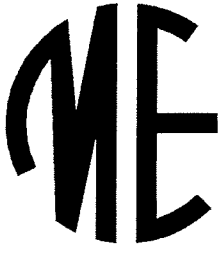

METRO ELECTRIC, INC.

TECL #17140

Main Office

1901 Industrial Dr.
McAllen, TX 78504
956.686.2323

Branch Office

5255 Commercial Dr.
Brownsville, TX 78523
956.831.7801

www.metroelectric-rgv.com

January 28, 2022

Morganti Texas, Inc.
112 E. Cano St.
Edinburg, TX 78539

Attention: Mr. Robert Gonzalez

Reference: Hidalgo County Courthouse
Metro CPR 105
Miscellaneous Changes

Gentlemen,

We submit the add sum for the scope of work detailed below in the amount of:

Four Thousand Five Hundred Seventy Four Dollars (\$4,574.00)

- Reinstall light fixtures in room 3C-022.
- Relocate three receptacles and one data outlet in room 3C-023. **Complete**
- Relocate one lighting control switch, one receptacle, and one exit light for relocated door 1C-131 MTI CPR 41.
- Add two Chief DB boxes to replace boxes not relocated by CPR 39.1.
- Add junction boxes for fire alarm modules for clean agent system. **Levels 1-4 Complete**
- Boxes and power for fire alarm relays at smoke dampers room 2A-143 (RFI 638)

We will proceed with this work upon receipt of your written change order.

Sincerely,
Metro Electric, Inc.

Stewart P. Gregorie

Stewart P. Gregorie
Sr. Project Manager

Cc: Andrew Munoz
Alejandra Icazbalceta
Job File 3419

Metro Electric, Inc., TECL #17140

Regulated by The Texas Department of Licensing and Regulation, P.O. Box 12157, Austin, Texas 78711, +1 (800)
803-9202, +1 (512) 463-6599;

website: <https://www.license.state.tx.us/complaints>.

Change Price Request Cost Analysis

PROJECT: Hidalgo County Courthouse
 CONTRACTOR: Morganti Texas, Inc.

DESCRIPTION OF CHANGE: Miscellaneous Changes

Metro Electric, Inc. CPR #105

Description	Quan. Reqd.	Material Cost	Unit	Material Total	Labor	Total
Reinstall light fixtures 3C-022	1.00			\$ -	\$ 321.82	
Relocate Power and Data 3C-023				\$ -	\$ -	
Old Work Box	4.00	\$ 5.99	E	\$ 23.96	\$ 72.41	
12-2 MC Cable	60.00	\$ 1,196.00	M	\$ 71.76	\$ 99.95	
MC /Connectors	6.00	\$ 116.86	C	\$ 7.01	\$ 43.45	
3/4 Flex Conduit	15.00	\$ 352.89	C	\$ 52.93	\$ 40.73	
3/4 Flex Connector	2.00	\$ 266.95	C	\$ 5.34	\$ 13.68	
3/4 Bushing	2.00	\$ 32.68	C	\$ 0.65	\$ 4.83	
Blank Plate	4.00	\$ 33.36	C	\$ 1.33	\$ 19.31	
Madison Strap	6.00	\$ 115.30	C	\$ 6.92	\$ 48.27	
Remove-Reinstall Receptacles	3.00			\$ -	\$ 54.31	
CPR 41 Relocate Devices for Door				\$ -	\$ -	
Old Work Box	2.00	\$ 5.99	E	\$ 11.98	\$ 36.20	
12-2 MC Cable	20.00	\$ 1,196.00	M	\$ 23.92	\$ 33.32	
MC /Connectors	2.00	\$ 116.86	C	\$ 2.34	\$ 14.48	
Remove-Reinstall Receptacles	1.00			\$ -	\$ 18.10	
Remove-Reinstall Lighting Control	1.00			\$ -	\$ 18.10	
Remove-Reinstall Exit Light	1.00			\$ -	\$ 40.23	
Two DB Boxes				\$ -	\$ -	
Chief PAC526PC	2.00	\$ 207.20	E	\$ 414.40	\$ 321.82	
Freight	1.00	\$ 69.57	E	\$ 69.57		
Telepro Fire Alarm for Clean Agent & RFI 638				\$ -	\$ -	
4 Sq Box	19.00	\$ 654.54	C	\$ 124.36	\$ 343.95	
4 Sq Extension Ring	3.00	\$ 854.03	C	\$ 25.62	\$ 22.93	
4 Sq Blank	19.00	\$ 130.07	C	\$ 24.71	\$ 91.72	
3/4 EMT	130.00	\$ 148.50	C	\$ 193.05	\$ 418.37	
3/4 EMT Connector	46.00	\$ 103.02	C	\$ 47.39	\$ 185.05	
3/4 Bushing	8.00	\$ 32.68	C	\$ 2.61	\$ 19.31	
3/4 Strap	16.00	\$ 156.00	C	\$ 24.96	\$ 241.37	
3/16 Toggle Bolt	48.00	\$ 50.00	C	\$ 24.00	\$ 386.18	
#12 THHN Sol Cu	120.00	\$ 339.79	M	\$ 40.78	\$ 48.27	
Subtotals				\$ 1,199.60	\$ 2,958.14	
Sales Tax				\$ -		
Subtotal w/ Tax				\$ 1,199.60		

Bond	\$ -
Subtotal (Material and Labor)	\$ 4,157.74
Plus 0.00 % of (Material and Labor)	\$ -
Subtotal (Material, Labor and Overhead)	\$ 4,157.74
Plus 10.00 OVERHEAD & PROFIT	\$ 415.77
Total (Material, Labor, Overhead, and Profit)	\$ 4,574











MTI-086-RFI 638 638.1 638.2 Added Smoke Dampers-5 - HDR (1)

Final Audit Report

2023-01-20

Created:	2023-01-17
By:	Jireh Lira (jireh.lcabello@co.hidalgo.tx.us)
Status:	Signed
Transaction ID:	CBJCHBCAABAAicps404PDsmXrT4UMMwyVNYwHIqTx5G2

"MTI-086-RFI 638 638.1 638.2 Added Smoke Dampers-5 - HDR (1)" History

-  Document created by Jireh Lira (jireh.lcabello@co.hidalgo.tx.us)
2023-01-17 - 7:47:00 PM GMT
-  Document emailed to fgotham@morganti.com for signature
2023-01-17 - 7:49:58 PM GMT
-  Email viewed by fgotham@morganti.com
2023-01-18 - 5:19:11 AM GMT
-  Signer fgotham@morganti.com entered name at signing as Frank Gotham
2023-01-18 - 5:06:19 PM GMT
-  Document e-signed by Frank Gotham (fgotham@morganti.com)
Signature Date: 2023-01-18 - 5:06:21 PM GMT - Time Source: server
-  Document emailed to john.niesen@hdrinc.com for signature
2023-01-18 - 5:06:25 PM GMT
-  Email viewed by john.niesen@hdrinc.com
2023-01-18 - 5:18:17 PM GMT
-  Signer john.niesen@hdrinc.com entered name at signing as J. Niesen
2023-01-19 - 3:59:22 PM GMT
-  Document e-signed by J. Niesen (john.niesen@hdrinc.com)
Signature Date: 2023-01-19 - 3:59:24 PM GMT - Time Source: server
-  Document emailed to Monica Salinas (monica.salinas@co.hidalgo.tx.us) for approval
2023-01-19 - 3:59:28 PM GMT



 Email viewed by Monica Salinas (monica.salinas@co.hidalgo.tx.us)

2023-01-19 - 4:50:12 PM GMT

 Document approved by Monica Salinas (monica.salinas@co.hidalgo.tx.us)

Approval Date: 2023-01-19 - 4:52:04 PM GMT - Time Source: server

 Document emailed to countyjudge@co.hidalgo.tx.us for signature

2023-01-19 - 4:52:08 PM GMT

 Email viewed by countyjudge@co.hidalgo.tx.us

2023-01-19 - 5:00:34 PM GMT

 Signer countyjudge@co.hidalgo.tx.us entered name at signing as Richard F Cortez

2023-01-20 - 4:12:28 PM GMT

 Document e-signed by Richard F Cortez (countyjudge@co.hidalgo.tx.us)

Signature Date: 2023-01-20 - 4:12:30 PM GMT - Time Source: server

 Document emailed to Karina Esparza (karina.esparza@co.hidalgo.tx.us) for approval

2023-01-20 - 4:12:37 PM GMT

 Email viewed by Karina Esparza (karina.esparza@co.hidalgo.tx.us)

2023-01-20 - 4:12:44 PM GMT

 Document approved by Karina Esparza (karina.esparza@co.hidalgo.tx.us)

Approval Date: 2023-01-20 - 5:44:45 PM GMT - Time Source: server

 Document emailed to arturo.guajardo@co.hidalgo.tx.us for signature

2023-01-20 - 5:44:49 PM GMT

 Email viewed by arturo.guajardo@co.hidalgo.tx.us

2023-01-20 - 5:49:00 PM GMT

 Signer arturo.guajardo@co.hidalgo.tx.us entered name at signing as Arturo Guajardo Jr.

2023-01-20 - 5:50:01 PM GMT

 Document e-signed by Arturo Guajardo Jr. (arturo.guajardo@co.hidalgo.tx.us)

Signature Date: 2023-01-20 - 5:50:03 PM GMT - Time Source: server

 Document emailed to Karina Esparza (karina.esparza@co.hidalgo.tx.us) for approval

2023-01-20 - 5:50:08 PM GMT

 Email viewed by Karina Esparza (karina.esparza@co.hidalgo.tx.us)

2023-01-20 - 5:50:13 PM GMT

 Document approved by Karina Esparza (karina.esparza@co.hidalgo.tx.us)

Approval Date: 2023-01-20 - 7:13:21 PM GMT - Time Source: server



✔ Agreement completed.

2023-01-20 - 7:13:21 PM GMT

