



**CITY OF HUBER HEIGHTS
STATE OF OHIO
City Council Meeting
Special Session
December 15, 2022
7:30 P.M.**

City Hall - Council Chambers - 6131 Taylorsville Road

1. **Call The Meeting To Order - Mayor Jeff Gore**
2. **Invocation** - Pastor Randy Griffith Of The Free Methodist Church At 6875 Old Troy Pike, Huber Heights, Ohio
3. **Pledge Of Allegiance**
4. **Roll Call**
5. **Approval Of Minutes**
 - A. City Council Meeting Minutes - November 28, 2022
6. **Special Presentations/Announcements**
7. **Citizens Comments**
8. **Citizens Registered to Speak on Agenda Items**
9. **City Manager Report**

10. **Pending Business**

- A. An Ordinance Increasing The Water Rates In Section 934.02 Of The Codified Ordinances Of Huber Heights.
(first reading)
- B. An Ordinance For Making Appropriations For Expenses Of The City Of Huber Heights, Ohio For The Period Beginning January 1, 2023 And Ending December 31, 2023.
(third reading)

11. **New Business**

CITY COUNCIL

Anthony Rodgers, Clerk of Council

- A. A Motion To Reappoint Scott Davidson To The Board Of Zoning Appeals For A Term Ending January 31, 2028.
- B. A Motion To Designate Nancy Byrge As The City Representative And Don Webb As The Alternate City Representative To The Miami Valley Regional Planning Commission (MVRPC) And To Designate Russ Bergman As The City Representative And Bryan Chodkowski As The Alternate City Representative To The Miami Valley Regional Planning Commission (MVRPC) Technical Advisory Committee For 2023.
- C. A Motion To Designate Anita Kitchen And Richard Shaw As City Representatives And Glenn Otto As The Alternate City Representative To The First Suburbs Consortium For 2023.
- D. A Resolution Authorizing The City Of Huber Heights To Renew An Agreement With Pickrel, Schaeffer And Ebeling For Legal Services As Law Director For The City Of Huber Heights, Ohio For The Time Period Of January 1, 2023 Through December 31, 2023.
(first reading)

ADMINISTRATION

Bryan Chodkowski, Interim City Manager

- E. A Resolution To Increase The Not To Exceed Amount For Joint Venture For Marketing Services For The Kroger Aquatic Center In Calendar Year 2022.
(first reading)

- F. An Ordinance Providing For The Continuation Of An Existing .25 Percent Levy On Income Effective January 1, 2025 And Expiring December 31, 2034, And To Submit This Ordinance To The Electorate For Approval Or Rejection And Contingent Upon Such Election Approval, Amend Section 192.012(B) Of Chapter 192, Income Tax, Of Title 9, Taxation Part I, Administration To Reflect The Tax Continuation.
(first reading)
- G. A Resolution Specifying May 2, 2023 As The Date For Submitting To The Electorate Of The City Of Huber Heights A Proposal To Provide For The Continuation Of An Existing .25% Levy On Income Effective January 1, 2025 And Expiring December 31, 2034 And Directing The Board Of Elections Of Montgomery County And Miami County, Ohio To Place The Issue On The Ballot.
(first reading)
- H. A Resolution Modifying Community Reinvestment Area #5 By Reducing The Boundaries Thereof.
(first reading)
- I. A Resolution Providing For The Second And Final Amendment Of Community Reinvestment Area #7.
(first reading)
- J. A Resolution Authorizing A Moral Claim For Tire Damage.
(first reading)
- K. A Resolution Amending And/Or Establishing The City Of Huber Heights Organizational Chart And Authorizing The New Personnel Staffing Levels As Detailed Below.
(first reading)
- L. A Resolution Authorizing The City Manager To Enter A Real Estate Exchange Agreement With Wright Way Ohio, LLC.
(first reading)
- M. An Ordinance Authorizing A One-Time Transfer Of Monies From The General Fund To Document An Advance Previously Made To The Community Development Block Grant Fund And Declaring An Emergency.
(first reading)
- N. An Ordinance Authorizing Advances And Transfers Between Various Funds Of The City Of Huber Heights, Ohio And Amending Ordinance No. 2021-O-2511 By Making Supplemental Appropriations For Expenses Of The City Of Huber Heights, Ohio For The Period Beginning January 1, 2022 And Ending December 31, 2022.
(first reading)
- O. A Resolution Authorizing The City Manager To Enter Into An Agreement With Patterson Pope To Purchase New Lockers And Benches For Both Locker Rooms In The Huber Heights Police Division And Waiving The Competitive Bidding And Request For Proposals Requirements.
(first reading)

- P. A Resolution Authorizing The City Manager To Award Purchase Of A Fire Division Fire Engine With Sutphen Corporation Waiving The Competitive Bidding Requirements.
(first reading)

- Q. A Resolution Accepting Certain Streets And Public Improvements For The Oaks Subdivision.
(first reading)

- R. A Resolution Accepting Certain Streets And Public Improvements For The Carriage Trails Subdivision.
(first reading)

- S. A Resolution Authorizing The City Manager To Enter Into A Contract For Fishburg Road/Endicott Road Storm Culvert Replacement Project And Waiving The Formal Bidding Requirements.
(first reading)

- T. A Resolution Declaring Certain City Property As No Longer Required For Municipal Purposes As Surplus And Authorizing Disposal Of Said Property.
(first reading)

12. **City Official Reports and Comments**

13. **Executive Session**

14. **Adjournment**

AI-8823

Minutes A.

City Council Special Meeting

Meeting Date: 12/15/2022

Approval of Minutes - 11/28/22

Submitted By: Anthony Rodgers

Department: City Council

Council Committee Review?: None

Date(s) of Committee Review: N/A

Audio-Visual Needs: None

Emergency Legislation?: No

Motion/Ordinance/ N/A

Resolution No.:

Agenda Item Description or Legislation Title

City Council Meeting Minutes - November 28, 2022

Purpose and Background

Approval of the minutes from the November 28, 2022 City Council Meeting.

Fiscal Impact

Source of Funds: N/A

Cost: N/A

Recurring Cost? (Yes/No): N/A

Funds Available in Current Budget? (Yes/No): N/A

Financial Implications:

There are no financial implications to this agenda item.

Attachments

Minutes

1. Call The Meeting To Order - Mayor Jeff Gore

The Huber Heights City Council met in a Regular Session on November 28, 2022.
Mayor Jeff Gore called the meeting to order at 6:30 p.m.

2. Invocation - Pastor John Gakwaya Of The Compassion Free Methodist Church At 6875 Old Troy Pike, Huber Heights, Ohio

3. Flag Ceremony - Wayne High School Junior ROTC Honor Guard

4. Pledge Of Allegiance

5. Roll Call

Present: Richard Shaw, Kathleen Baker, Nancy Byrge, Glenn Otto, Ed Lyons, Anita Kitchen, Don Webb, Jeff Gore

Absent: Mark Campbell

Mayor Gore said Mr. Campbell sent an email asking for his absence to be excused.

Mrs. Byrge moved to approve Mr. Campbell's absence; Ms. Baker seconded the motion. On a call of the vote, Ms. Baker, Mrs. Byrge, Mr. Otto, Mr. Lyons, Mrs. Kitchen, Mr. Webb, and Mr. Shaw voted yea; none voted nay. The motion passes 7-0.

6. Approval Of Minutes

- A. City Council Meeting Minutes - November 14, 2022

7. Special Presentations/Announcements

There were no Special Presentations or Announcements.

8. Citizens Comments

Mr. Jeff Morford said he is a Miami County/Bethel Township resident. He discussed the pending annexation. He said the citizens of Bethel Township do not want the development or the annexation and development in Huber Heights. He said New Carlisle voted against an annexation request. He suggested the Huber Heights City Council propose legislation that would mandate future annexation requests, if accepted by Huber Heights, be put on the ballot as a final safeguard. He said, this way, the Huber Heights citizens' vote would be a reflection as to what the community wants and how they want their community perceived by their neighbors. He said Councilmembers may be voting with what are good business practices, but maybe the citizens have a different idea as to the direction of the City.

9. Citizens Registered to Speak on Agenda Items

Mr. Rodgers said he has one citizen registered to speak on Item 12-A.

10. City Manager Report

Interim City Manager Bryan Chodkowski said representatives of the Huber Heights Senior Center met with representatives from LWC, the architectural firm engaged to help the City design the new civic center. He said with regard to design, City Staff notified Council at the last Council Work Session that numerous bids were received for design services for the new Public Works Division building. He said based on review of those proposals, both the City Engineer and the Public Works Manager would like to interview a few of those firms based on the review of the information that was presented prior to making a final recommendation to Council. He said this Saturday is the annual Christmas Concert and Tree Lighting at the Eichelberger Amphitheater. He said the event will begin at 5:00 p.m. and includes free hot chocolate, goodies, wagon rides, and photo opportunities with Santa. He said the Dayton Scottish Dancers will also be in attendance as well as the Rushmore Elementary School and the First Christian Church Children's Choirs.

Mrs. Byrge asked Mr. Chodkowski if it is possible for Council to get a copy of what LWC presented to the Huber Heights Senior Center.

Mr. Chodkowski said he could follow up with LWC to get that information. He said the floor plan and the layout the representatives have seen is not significantly dissimilar to the one provided to Council before he and the Clerk of Council met with LWC.

11. Pending Business

- A. An Ordinance For Making Appropriations For Expenses Of The City Of Huber Heights, Ohio For The Period Beginning January 1, 2023 And Ending December 31, 2023.
(second reading)

Mr. Chodkowski said the Finance Director has requested that this item be moved to a third reading so final adjustments can be made with respect to fund balances and any last minute expenses identified by City Staff prior to the actual adoption of the legislation.

Mayor Gore said the Council Work Session recommendation was to pass this item to a third reading.

Mr. Lyons said at the last Council Work Session, Mr. Chodkowski talked about the water study and the recommendation to put \$4 million in the budget for consecutive years. He said Mr. Chodkowski stated he would bring this matter back to Council early next year, and several Councilmembers voiced their recommendation that this item be brought back sooner as opposed to later. He asked, with the 2023 City Budget coming up for a vote next month, if Mr. Chodkowski anticipates making a recommendation to increase that amount at the next Council Work Session.

Mr. Chodkowski said he recalled as part of that discussion, his recommendation to Council was to allow City Staff time to put together a more structured presentation on the recommendation on how such funds would be made available based on the information and the limited amount of time to respond to that information and its relation to the budget. He said that is what he recalls his comments being. He said he does not recall there being a definitive direction from the majority of members of Council to make any changes to the budget. He said that is why the budget as presented tonight for the second reading and to be presented for the third reading, unless directed otherwise tonight, would include the original \$1.3 million budgeted for the Water Main Replacement Program. He said any subsequent changes to that budget amount could be made by Council following presentations later based on the information City Staff would bring forward.

Mr. Lyons said that is what he wanted to know. He said sooner rather than later was the directive that was put out, but there were no dates or months. He said he just

wanted to clarify.

Mr. Chodkowski said one of the authors of the study will present the findings of the study in greater detail than City Staff's initial summary and in a more concise manner than the report itself at the February 23, 2023 Council Work Session.

Mr. Lyons said he was looking specifically at whether there was going to be a recommendation for the budget for that line item and the answer is no.

Mr. Otto said he would like to see a number closer to that \$4 million before he can support this legislation. He said it is urgent and important to the City, and he believes the money can be found. He said the City finds money for other things and he thinks money can be found for this expenditure.

Mrs. Kitchen said she seconded what Mr. Otto said, and she will not be in support of it unless more money is put into the Water Fund.

Mayor Gore said this item will be moved to a third reading.

12. New Business

ADMINISTRATION

Bryan Chodkowski, Interim City Manager

- A. A Resolution Establishing And/Or Amending The City Of Huber Heights Organizational Chart And Authorizing The New Personnel Staffing Levels As Detailed Below.
(first reading)

Mr. Chodkowski said as Council was briefed at the Council Work Session, this item provides for the various staffing positions within the organization and the number of those positions.

Ms. Baker moved to adopt; Mrs. Byrge seconded the motion.

Mr. Vince King said this legislation takes the Park Manager position down to a Park Technician position. He asked what that change will do for the community, the City, the parks, and the programs since the establishment of that position and the citizens' recommendation in the Parks Master Plan to have someone dedicated and focused on the parks. He said this change seems like a complete 180. He said this change is taking a position that is dedicated to focusing on the parks and making sure the parks have the amenities and repairs needed. He asked Council if they are truly in support of this change and will someone be focused on those things in the future. He said the community needs to have a voice in this decision as well. He said he wants to make sure the City is moving forward and lives up to the slogan, "Come Grow With Us".

Mr. Otto said he had similar thoughts when looked over everything. He said he agrees the City made a move to bolster the park system by having a Parks Manager and hoped it would lead to an actual Parks Department due to the size of the City. He said Huber Heights is one of the largest cities, and other cities have full-time Parks and Recreation Departments. He said he is curious how the City got to this point.

Mayor Gore said what he heard in Mr. Chodkowski's discussion of this item in the Council Work Session was a move to efficiency. He said he is frustrated this conversation did not come up at the actual Council Work Session where Council talks about these things instead of getting to the meeting and now having all of this discussion. He said no one said anything at the Council Work Session. He said he will allow Mr. Chodkowski to address the reasoning and why the recommendation is being made from a staff level.

Mr. Chodkowski read the email that he sent to Council on November 18, 2022, to explain why the recommendation is being made. In summary, he said operational efforts need to expand beyond activation of updated or new recreational spaces to

include general asset oversight and management. He said this position is reflective of more time spent in the field addressing asset maintenance and management issues to protect the City's investments. He said operational efficiency is also a key reason for the relocation of this position. He said the Parks Division has no maintenance equipment or staffing of its own, relying on the Public Works Division. He said this condition has created situations where the work needs of the park conflict with the work of the Public Works Division. He said locating this position under the Public Works Division should substantially reduce these conflicts and increase efficiency. He said the YMCA is planning to increase its programming outreach in 2023 to a number of City facilities including the Huber Heights Senior Center, the Huber Heights Community Center, and the Eichelberger Amphitheater. He said the functions of the Park Manager position such as programming and facility reservations are not internally necessarily moving forward.

Mr. Shaw said there was no conversation at the Council Work Session, and that was an opportunity for him to review and further sleep on this matter. He said he has a secondary issue with the Tax Division as well. He said he made it clear the Tax Division needs help. He said it would be his request to further this conversation so as to push this discussion off to the next Council Work Session for additional conversation and discussion on the merits that have been presented.

Mr. Lyons said he had time to think and digest this matter. He said he does find it a little hard to understand moving the Parks Manager underneath the Public Works Director. He said that is moving another layer of decision-making over the parks. He said it would be more efficient to keep it separate and have the decisions made, and then the City Manager has to decide if that should happen and then put it on the schedule for the Public Works Division. He said the organizational chart shows a Parks Technician, and then the Public Works Manager can say no and it is dead there. He said on a separate subject, the organizational chart does not have numbers on each individual position, but down at the bottom of the organizational chart are the total number of positions broken down. He said the Fire Division has 63 full-time positions. He asked how many positions are firefighter/paramedic non-supervisory positions.

Mr. Chodkowski said he did not know and that is why the Fire Chief was in attendance at the Council Work Session, so in the event that question was asked, the appropriate person was there to answer that question.

Mr. Rodgers said it is in the legislation itself above the Table Of Organization.

Mr. Webb said simply the Parks Manager had to go back to the Public Works Manager every time he needed something. He said it is not a step backward, but a more efficient utilization, and he explained his position.

Mrs. Byrge said it is up to department heads to define the manpower requirements are and not up to Council. She said what would help clear this matter up for everyone, was if Mr. Chodkowski could reaffirm the commitment to the direction the parks have been going in up to this point and where he plans for it to go in the future, regardless of how he has realigned the City Staff.

Mr. Chodkowski said the goal is to go forward, not backward, and to protect the City's assets. He said in order to do that, City Staff needs to make sure that all of the resources in manpower and equipment are being aligned accordingly. He discussed the plan for City Staff and resources in depth. He said he does not want this effort to be a failure, and he is recommending this change based on his 25 years of experience. He said what Council does tonight has an ability to affect 200 plus positions that are just as meaningful and important. Mr. Chodkowski explained to Mr. King that there is a time and a place for all of the conversations and these are all conversations City Staff plan to have, but things have to happen in a certain order by the nature of how this business works. He said this legislation is the first domino that has to fall in a series of other actions.

Mayor Gore said there is a first and second on the motion to adopt and also a recommendation from Mr. Shaw to move this item to a second reading. He explained the options.

Mr. Otto said he supports the recommendation to move this item to a second reading for more discussion.

Mrs. Byrge asked how Council can make an assessment of how moving that position title from one place to another is going to impact how the position operates.

Mayor Gore interrupted and said the time for discussion was over unless this item is moved to a second reading. He instructed Mr. Rodgers to call the vote.

On a call of the vote, Mrs. Byrge, Mr. Webb, Mr. Shaw, and Ms. Baker voted yea; Mr. Otto, Mr. Lyons, and Mrs. Kitchen voted nay. The motion fails 4-3.

B. A Resolution Establishing And/Or Amending The Salary Ranges And Wage Levels For Employees Of The City Of Huber Heights, Ohio.
(first reading)

Mr. Chodkowski said for the various positions within the City's Table Of Organization, this legislation sets the salary ranges for those positions. He asked that Council act on this item tonight and adopt the measure.

Mr. Rodgers said this legislation does list the salary ranges by position title. He said the Parks Technician position would be on this legislation. He said it could be passed to another reading and if something is brought back that relates to Item 12-A, this legislation could be amended to reflect whatever changes are made to the organizational chart.

Mr. Chodkowski said there are other provisions within this legislation that matter. He said since this legislation is effectively talking about one position he is aware of, the implication is that this legislation is more important with regard to all of the remaining positions. He asked that Council adopt this legislation tonight. He said with the failure of the previous legislation, none of the position titles are changing. He said he would remind Council that this legislation and the legislation prior are not just about positions, but are also about people. He said it is important Council is very conscientious about what they say with respect to positions and people in the public forum. He asked that those of Council with concerns utilize the ability to communicate with his office in advance of the public forum so he can address all of the questions and concerns as thoroughly as he can in the most appropriate venue before they are back in Council Chambers where they have to be thoughtful about their comments and thoughtful about statements on not just the positions within the Table Of Organizations but about the employees. He said with respect to those comments, he asked the Council to adopt this legislation in consideration to all employees in those positions.

Mayor Gore said this issue has been addressed before about Councilmembers coming to City Council Meetings not prepared at the Council Work Session to address the items that are on the agenda. He said there are situations where Council comes to Council Work Sessions and no one says anything and they do not have discussions. He said Mr. Chodkowski sent out an email well in advance of a week regarding this matter, and then tonight he heard, "I did not have time." He said that was the point of the Council Work Session.

Mr. Otto said the Council Work Session is where information is presented to Council, and he does not always like to make snap decisions. He said he likes to chew on things a little bit and that is why Council does not make decisions on the night the information is received. He said Council has adjusted time frames and processes over the years. He said there used to be two readings for resolutions and multiple readings on ordinances and that has been changed all around, so now Council is looking at passing resolutions on the first reading after a Council Work Session. He said a Council Work Session is where Council receives the information to do its due diligence and to research and chew on and think about what they are voting on before coming back to vote on it. He said he will not say he is unprepared at all.

Mayor Gore said Mr. Chodkowski sent an email on November 18, 2022. He said he knows each and every one of Council communicates with Mr. Chodkowski regularly,

he knows each and every one meets with him individually and sometimes collectively. He said waiting until the night of the meeting to have discussions where there is so much concern that would determine the outcome of the vote based on the people in the organization, he certainly can see, feel, and understand the frustration. He said whenever anyone needs anything else, they never care to reach out to Mr. Chodkowski to send him an email, give him a call, meet him for lunch, or meet him in his office. He said on this item, no one said a word.

Mr. Shaw said he would request this item be passed on to a second reading to allow Council more time for discussion at the Council Work Session in hopes of bringing back a companion piece to meet with this item.

Mrs. Byrge said she fails to see the objective. She asked how it would change?

Mayor Gore said there was a vote based on the organizational chart, and that motion failed. He said Council needs to determine if there is an objection to Mr. Shaw wanting to move Item 12-B to a second reading.

Mrs. Byrge asked Mr. Chodkowski if this item moves to a second reading if Mr. Chodkowski would please be prepared to discuss at the next Council Work Session the ramifications of these two issues not passing before the end of the year. She said obviously, there are people on this dais who do not understand how the process works and want to play games.

Mayor Gore said Council is not going to go there and he asked if there was an objection to Mr. Shaw's motion to move to another reading.

Mrs. Byrge said she had no objection.

Mr. Otto said he has no objections. He asked Mr. Rodgers if Item 12-B passing creates any issue for him.

Mr. Rodgers said the salary range would not be defined for the Parks Manager because it is listed on the current legislation as a Parks Technician. He said there would be the option to possibly make an amendment to that legislation or there could be some cleanup that could be done at a later date.

Mr. Shaw asked Mr. Rodgers if this item were to pass with the previous item failing, if that would be his only concern.

Mr. Rodgers said it is defined in the legislation as a position that does not exist.

Mr. Shaw asked if there would be an appropriate time tonight to amend this legislation to maintain the Parks Manager in the legislation instead of the Parks Technician and then this legislation can always be brought back up at a later date, so that way the salary ranges that are set forth by other employees still move forward.

Mayor Gore said he would assume the legislation can be amended.

Mr. Shaw said if that is the case, he withdraws his request and he said Council should move on this item tonight. He said the complete Table Of Organization can be discussed at the next Council Work Session. He suggested amending the legislation to read Parks Manager instead of Parks Technician.

Mr. Rodgers said right now in the legislation the Parks Technician is listed under the Department of Public Services. He said he did not know where it was listed before. He discussed position control numbers and salary ranges. He said to change to Park Manager, it would have to be with the current pay grade, position control number, and in the appropriate place in the legislation. He said without having the previous legislation in front of him, he did not know what those numbers were to make an amendment unless the Law Director would think it appropriate to give general guidance to make that switch as an amendment and to switch those two items in the legislation.

Mr. Montgomery said the most prudent way to go would be to amend the legislation with specific information and that way it is consistent with the legislation itself as to

the category, pay grade, and appropriate title. He said that is not to say Council could not make a motion to approve with appropriate cleanup language. He said it could probably be worded in such a way to approve subject to or contingent upon.

Mayor Gore said he recommends giving Mr. Chodkowski and Mr. Rodgers the opportunity to clean up the language and bring it back to the Council Work Session. He asked Mr. Chodkowski what effect it would have if it does not pass until December.

He said this legislation provides for appropriate wage increases for employees. He said there may be some issues processing and making sure those employees eligible for increases get those increases in a timely manner.

Ms. Baker suggested to Mayor Gore that the Law Director and Clerk of Council take a ten-minute recess to work on the language.

Mr. Lyons asked if this legislation would take effect immediately and if employees would be paid immediately and changes would be made tomorrow.

Mr. Chodkowski said the compensation schedule takes effect on December 18, 2022, so technically, the legislation would go into effect when it is adopted. He said the legislation triggers the compensation. He said if Council waits to adopt it on December 12, 2022, he cannot guarantee that gives the Finance Department adequate time with its other responsibilities to put together all the necessary information and accommodate all the appropriate wage changes within the appropriate amount of time.

Mr. Lyons asked what compensation is being talked about?

Mr. Chodkowski explained the non-collective bargaining and collective bargaining employees receive annual increases. He said all non-union employees would receive a 2.75 percent rate increase starting on the pay period beginning December 18, 2022.

Mr. Lyons confirmed with Mr. Chodkowski that the contract begins on December 18, 2022, not January 1, 2023.

Mr. Chodkowski said it starts for the pay period that ends under the first portion of the new contract. He said the pay period ends in January of 2023. He said if it starts on the December 18, 2022 and ends in January, 2023, that is why it applies to that pay period.

Mr. Lyons said if Parks Technician is pulled out of the legislation, there should be enough votes to pass this item tonight.

Mr. Montgomery posed a draft motion for Council's consideration and he read it out loud.

Mr. Shaw made a motion to amend the legislation with the proposed language; Ms. Baker seconded the motion.

Mr. Webb said since Council did not approve the organizational chart, Council should not be amending a position that does not exist. He said he does not see any harm in leaving in the Parks Technician position.

Mr. Chodkowski described the situation to Council. He said he would have to assume the Finance Department has the ability and capability if it needs to retroactively or immediately address a wage issue for one position within the organization, it has the ability to do so within a six-day period. He explained the measures that would need to be taken at the next City Council Meeting if this legislation were passed tonight.

Mr. Shaw withdrew his motion; Ms. Baker withdrew her second to the motion.

Ms. Baker moved to adopt legislation as presented; Mrs. Kitchen seconded the motion. On a call of the vote, Mr. Otto, Mr. Lyons, Mrs. Kitchen, Mr. Webb, Mr. Shaw, Ms. Baker, and Mrs. Byrge voted yea; none voted nay. The motion passes 7-0.

- C. A Resolution Repealing Section 8.1 Of Article 8 – Employee Benefits Of The City’s Employee Personnel Manual For City Of Huber Heights Employees And Adopting A New Section 8.1 To The City Of Huber Heights Employee Personnel Manual.
(first reading)

Mr. Chodkowski said this legislation provides for an adjustment of the City's health insurance benefits for employees, specifically regarding the insurance opt-out provision for spouses.

Mayor Gore said the Council Work Session recommendation was to adopt this item.

Mr. Shaw moved to adopt; Mr. Webb seconded the motion. On a call of the vote, Mr. Lyons, Mrs. Kitchen, Mr. Webb, Mr. Shaw, Ms. Baker, Mrs. Byrge, and Mr. Otto voted yea; none voted nay. The motion passes 7-0.

- D. A Resolution Authorizing Certain Actions Made To Amend All Of The Current Collective Bargaining Agreements And The City Of Huber Heights Employee Personnel Manual To Recognize Christmas Eve As A Full Day City Paid Holiday For All Employees.
(first reading)

Mr. Chodkowski said this resolution is brought forth to provide for the full holiday of Christmas Eve for City employees.

Mayor Gore said the Council Work Session recommendation was to adopt this item.

Mrs. Byrge moved to adopt; Mr. Shaw seconded the motion.

Mr. Webb thanked the City Manager and said this holiday was an excellent suggestion and a benefit for the employees.

On a call of the vote, Mrs. Kitchen, Mr. Webb, Mr. Shaw, Ms. Baker, Mrs. Byrge, Mr. Otto, and Mr. Lyons voted yea; none voted nay. The motion passes 7-0.

- E. A Resolution Authorizing The City Manager To Negotiate And Enter Into A Second Lease Agreement With Columbia Building Company Regarding The Huber Heights Tax Division Office.
(first reading)

Mr. Chodkowski said this lease allows the Tax Division to stay at the current location at the Huber Centre, but provides the flexibility to vacate the premises in the future once rehabilitating and relocating various operations is complete.

Mr. Webb moved to adopt; Mrs. Kitchen seconded the motion. On a call of the vote, Mr. Webb, Mr. Shaw, Ms. Baker, Mrs. Byrge, Mr. Otto, Mr. Lyons, and Mrs. Kitchen voted yea; none voted nay. The motion passes 7-0.

- F. A Resolution Declaring Certain Property Eligible For Alternative Special Assessment Under Section 176.05 Of The Huber Heights Codified Ordinances And Authorizing The Director Of Finance To Assess The Property.
(first reading)

Mr. Chodkowski said this legislation is brought forth to accommodate a utility connection under various City codes.

Mayor Gore said the Council Work Session recommendation was to adopt this item.

Mrs. Byrge moved to adopt; Mr. Otto seconded the motion. On a call of the vote, Mr. Shaw, Ms. Baker, Mrs. Byrge, Mr. Otto, Mr. Lyons, Mrs. Kitchen, and Mr. Webb voted yea; none voted nay. The motion passes 7-0.

- G. An Ordinance Directing The Board Of Elections Of Montgomery County And Miami County To Place On The Ballot Of The Next Election The Question Of Whether The City Of Huber Heights Should Effect A Governmental Natural Gas Aggregation Program With Opt-Out Provisions Pursuant To Section 4929.26 Of The Ohio Revised Code.

(first reading)

Mr. Chodkowski said this ordinance brings forth the measure of natural gas aggregation to the ballot in May, 2023.

Mayor Gore said the Council Work Session recommendation was to waive the second reading and to adopt this item.

Ms. Baker moved to waive the second reading; Mrs. Byrge seconded the motion. On a call of the vote, Ms. Baker, Mrs. Byrge, Mr. Otto, Mr. Lyons, Mrs. Kitchen, Mr. Webb, and Mr. Shaw voted yea; none voted nay. The motion passes 7-0.

Mr. Lyons moved to adopt; Mrs. Kitchen seconded the motion.

Mrs. Kitchen said social media has been lighting up about how Council is trying to control everything. She encouraged residents to vote when this item is on the ballot and make their wishes known.

On a call of the vote, Mrs. Byrge, Mr. Otto, Mr. Lyons, Mrs. Kitchen, Mr. Webb, Mr. Shaw, and Ms. Baker voted yea; none voted nay. The motion passes 7-0.

- H. A Resolution Authorizing The City Manager To Enter Into A Contract With Woolpert For Professional Services For The Comprehensive Facilities Maintenance Plan Project.
(first reading)

Mr. Chodkowski said this is an opportunity to put together a plan to make sure the City is maintaining the assets created. He asked that this item be adopted tonight so City Staff can engage Woolpert to create this plan.

Mayor Gore said the Council Work Session recommendation was to adopt this item.

Mr. Webb moved to adopt; Ms. Baker seconded the motion. On a call of the vote, Mr. Otto, Mr. Lyons, Mrs. Kitchen, Mr. Webb, Mr. Shaw, Ms. Baker, and Mrs. Byrge voted yea; none voted nay. The motion passes 7-0.

- I. A Resolution Authorizing The City Manager To Enter Into Contract For The Mardi Gras Area Water Main Replacement Project.
(first reading)

Mr. Chodkowski said this resolution allows the City to make certain improvements in the Mardi Gras Drive area to replace old and outdated water main and to improve the utility conditions for residents in that area.

Mayor Gore said the Council Work Session recommendation was to adopt this item.

Mrs. Byrge moved to adopt; Mr. Shaw seconded the motion. On a call of the vote, Mr. Lyons, Mrs. Kitchen, Mr. Webb, Mr. Shaw, Ms. Baker, Mrs. Byrge, and Mr. Otto voted yea; none voted nay. The motion passes 7-0.

- J. A Resolution Authorizing The City Manager To Solicit Requests For Proposals From Qualified Consulting Firms To Provide Engineering Design For The Installation Of New Well No. 7 At The Rip Rap Road Water Treatment Plant.
(first reading)

Mr. Chodkowski said this legislation will allow City Staff the ability to begin designing the new well so when the property acquisition is complete, construction can begin sooner rather than later.

Mayor Gore said the Council Work Session recommendation was to adopt this item.

Mr. Shaw moved to adopt; Ms. Baker seconded the motion. On a call of the vote, Mrs. Kitchen, Mr. Webb, Mr. Shaw, Ms. Baker, Mrs. Byrge, Mr. Otto, and Mr. Lyons voted yea; none voted nay. The motion passes 7-0.

13. City Official Reports and Comments

Mr. Lyons said regarding the ordinance passed tonight dealing with the election ballot for natural gas aggregation, he wants to remind everyone in the City that it is the perfect legislation. He said even though it deals with City-wide aggregation in a program, it gives every resident the opportunity to opt out per the City's legislation and per state law. He said if someone does not like the program, the ability is there to opt out and choose a provider.

Mayor Gore said when you look at the success of the energy aggregation legislation passed six or seven years ago, the residents saved hundreds of thousands if not millions of dollars. He said residents were upset when the program ended and everyone saw what AES was charging with the regular rates. He said it only makes sense to give the residents who want that opportunity, the opportunity to at least have a say and a vote.

Mr. Shaw said Mr. Otto has been in communication with some opportunities from the National League of Cities Conference. He said he will hopefully be having a conversation with the City Manager later this week to discuss some of the items he brought back as well involving infrastructure so it is his hope Council sees those funds for water projects in the upcoming budget. He said it is his understanding that the Miami County Commissioners will be taking up the writ of mandamus on the annexation. He said it is his hope that he will be attending that meeting as well. He said he hopes Council sees the Table Of Organization for discussion at the next Council Work Session. He said he hopes everyone enjoys the Christmas Concert. He said the City has done a great job for many years with the Christmas Concert.

14. Executive Session

There was no need for an Executive Session.

15. Adjournment

Mayor Gore adjourned the Regular Session City Council Meeting at 7:52 p.m.

Clerk of Council

Date

Mayor

Date

AI-8865

**New Business A.
City Manager**

City Council Special Meeting

Meeting Date: 12/15/2022

Water Rate Ordinance

Submitted By: Jim Bell

Department: Finance

Division: Accounting

Council Committee Review?: Council
Work
Session

Date(s) of Committee Review: 12/06/2022

Audio-Visual Needs: None **Emergency Legislation?:** No

**Motion/Ordinance/
Resolution No.:**

Agenda Item Description or Legislation Title

An Ordinance Increasing The Water Rates In Section 934.02 Of The Codified Ordinances Of Huber Heights.
(first reading)

Purpose and Background

Following discussion at the City Council Work Session on December 6, 2022, City Council instructed City Staff to prepare legislation to increase the water rates by 7.5%, beginning with the February 1, 2023 billings, to collect an estimated \$500,000 to use for engineering and design of a total of \$4 million of water main replacement to begin in 2023. The increase would raise the water portion of an average monthly utility bill by \$2.66. City Staff recommend the second reading be waived and this legislation be adopted at the December 15, 2022 City Council Meeting so that the rate increase will be effective beginning February 1, 2023.

Fiscal Impact

Source of Funds: N/A

Cost: N/A

Recurring Cost? (Yes/No): N/A

Funds Available in Current Budget? (Yes/No): N/A

Financial Implications:

Attachments

Ordinance

CITY OF HUBER HEIGHTS
STATE OF OHIO

ORDINANCE NO. 2022-O-

INCREASING THE WATER RATES IN SECTION 934.02 OF THE CODIFIED ORDINANCES OF HUBER HEIGHTS.

WHEREAS, Section 934.02 of the Codified Ordinances of the City of Huber Heights sets forth the water distribution rates for all municipal water customers; and

WHEREAS, Council has determined it is necessary to increase the water distribution rates across the board effective in February 2023 by seven and one-half percent (7.5%).

NOW, THEREFORE, BE IT ORDAINED by the City Council of Huber Heights, Ohio that:

Section 1. Effective with the first billing in February 2023, Section 934.02(a), (b) and (c) of Chapter 934 Rates and Fees for Water Distribution of Title Three, Public Utilities, of Part Nine Streets and Public Services, of the Codified Ordinances of the City of Huber Heights is hereby amended to read as follows:

934.02 WATER DISTRIBUTION RATES.

(a) Except as provided elsewhere in this section, water rates for all customers, including customers that reside within the City limits that are in the Huber East Water District System shall be as follows.

- (1) The billing period shall be monthly and include estimated or actual readings.
- (2) The water rates to be charged shall be based on the volume of water consumption and the size of the water meter(s) servicing a property as follows:

Effective with the first billing in April 2022:	Effective with the first billing in April 2022:
Consumption Volume	Rate Per 100 Cubic Feet
0 to 1500 cubic feet	\$2.5758
Over 1500 cubic feet	2.1779

Effective with the first billing in February 2023:	Effective with the first billing in February 2023:
Consumption Volume	Rate Per 100 Cubic Feet
0 to 1500 cubic feet	\$2.7690
Over 1500 cubic feet	2.3412

(3) Monthly service charges for water distribution services shall be based on the size of the largest meter servicing a property as follows:

Effective with the first billing in April 2022:	Effective with the first billing in April 2022:	Effective with the first billing in April 2022:
Meter Size	Residential User Service Charge	Commercial User Service Charge
5/8"	\$14.87	\$14.87
1"	36.76	36.76
1 1/2"	73.28	78.20
2"	117.05	124.88
3"	219.23	233.87
4"	370.32	395.12

Effective with the first billing in February 2023:	Effective with the first billing in February 2023:	Effective with the first billing in February 2023:
Meter Size	Residential User Service Charge	Commercial User Service Charge
5/8"	\$15.99	\$15.99
1"	39.52	39.52
1 1/2"	78.78	84.07
2"	125.83	134.25
3"	235.67	251.41
4"	398.09	424.75

Monthly service charges for water distribution for meter sizes not enumerated above shall be determined by the City Engineer in proportion to the rates for meter sizes listed above. The Citizens Water and Sewer Advisory Board shall hear appeals concerning service charge determinations by the City Engineer and provide a recommendation of final action to the City Council. The City Council shall make the final decision regarding any appeal concerning service charge determinations by the City Engineer.

(b) Except as otherwise provided in this section, Huber East Water District customers located outside of the City limits shall pay rates according to the following schedule:

(1) Monthly service charge based on meter size.

Effective with the first billing in April 2022:	Effective with the first billing in April, 2022:
Meter Size	Service Charge
5/8"	\$22.01
1"	52.87
1 1/2"	104.30
2"	165.98
3"	309.98

Effective with the first billing in February 2023:	Effective with the first billing in February 2023:
Meter Size	Service Charge
5/8"	\$23.66
1"	56.84
1 1/2"	112.12
2"	178.43
3"	333.23

(2) Volume charge based on the volume of consumption per cubic feet.

Effective with the first billing in April 2022:	Effective with the first billing in April 2022:
Consumption Volume	Rate Per 100 Cubic Feet
0 to 1500 cubic feet	\$5.9690
Over 1500 cubic feet	5.1536

Effective with the first billing in February 2023:	Effective with the first billing in February 2023:
Consumption Volume	Rate Per 100 Cubic Feet
0 to 1500 cubic feet	\$6.4167
Over 1500 cubic feet	5.5401

(c) Water Rates for Commercial/Industrial Customers not Within the City Limits.

(1) Commercial/Industrial Water District customers located outside of the City limits shall pay rates according to the following schedule:

A. Monthly service charge based on meter size.

Effective with the first billing in April 2022:	Effective with the first billing in April 2022:
Meter Size	Service Charge
5/8"	\$26.43
1"	63.46
1 1/2"	133.57
2"	212.54
3"	396.90

Effective with the first billing in February 2023:	Effective with the first billing in February 2023:
Meter Size	Service Charge
5/8"	\$28.41
1"	68.22
1 1/2"	143.59
2"	228.48
3"	426.67

B. Volume charge based on the volume of consumption per cubic feet.

Effective with the first billing in April 2022:	Effective with the first billing in April 2022:
Consumption Volume	Rate Per 100 Cubic Feet
0 to 1500 cubic feet	\$7.1625
Over 1500 cubic feet	6.2017

Effective with the first billing in February 2023:	Effective with the first billing in February 2023:
Consumption Volume	Rate Per 100 Cubic Feet
0 to 1500 cubic feet	\$7.6997
Over 1500 cubic feet	6.6668

(d) Customer Equivalents. When the City agrees to provide service to apartment buildings, condominiums, townhouses, mobile home parks and office buildings to which water is furnished through a single meter, for the purpose of distribution to several customers, such billings shall be determined on the following bases:

(1) The amounts of each such billing shall be determined on the basis of the "customer equivalents" provided by the meter employed. Such customer equivalents shall be determined by comparing the size of the meter in cross-section area with the cross-section area of the five-eighths inches meter, which is the size of meter most typically installed on a service line which serves a single-family dwelling or single professional or business office. Such relationship is as follows:

Meter Size	Customer Equivalent
5/8"	1 Customer Equivalent
1"	2.5 Customer Equivalent
1 1/2"	5 Customer Equivalent
2"	8 Customer Equivalent
3"	15 Customer Equivalent
4"	40 Customer Equivalent

(2) To determine the amount of any billing for water service pursuant to such special arrangement:

A. The total consumption through the meter during the billing period will be divided by the customer equivalent for the meter included:

B. The applicable usage rates contained in this chapter will then be applied to the quotient to determine the charge per customer equivalent; and

C. Such charge per equivalent will then be multiplied by the customer equivalent for that meter, the product of such multiplication plus the customer charge producing the total bill as to that meter for that billing period.

Section 2. Nothing herein shall affect the annual cost of living increase based on the Consumer Price Index pursuant to Ordinance No. 2018-O-2343.

Section 3. It is hereby found and determined that all formal actions of this Council concerning and relating to the passage of this Ordinance were adopted in an open meeting of this Council and that all deliberations of this Council and of any of its Committees that resulted in such formal action were in meetings open to the public and in compliance with all legal requirements including Section 121.22 of the Ohio Revised Code.

Section 4. This Ordinance shall go into effect upon its passage as provided by law and the Charter of the City of Huber Heights.

Passed by Council on the _____ day of _____, 2022;
_____ Yeas; _____ Nays.

Effective Date:

AUTHENTICATION:

Clerk of Council

Mayor

Date

Date

AI-8867

New Business B.
Finance

City Council Special Meeting

Meeting Date: 12/15/2022

2023 City Budget

Submitted By: Jim Bell

Department: Finance

Division: Accounting

Council Committee Review?: Council Work Session

Date(s) of Committee Review: 10/18/2022, 11/07/2022, 11/22/2022, 12/6/2022

Audio-Visual Needs: None **Emergency Legislation?:** No

**Motion/Ordinance/
Resolution No.:**

Agenda Item Description or Legislation Title

An Ordinance For Making Appropriations For Expenses Of The City Of Huber Heights, Ohio For The Period Beginning January 1, 2023 And Ending December 31, 2023.
(third reading)

Purpose and Background

The final draft of the 2023 City Budget is included (see attached). The 2023 City Budget for the Local Street Operating Fund is balanced. The General Fund, Police Fund, Fire Fund, and Parks and Recreation Fund are structurally balanced (current carryover fund balances cover any excess spending in 2023). The final draft of the 2023 City Budget totals \$110,501,537 for all funds. The 2023 General Fund Budget totals \$18,720,488.

The proposed 2023 City Budget Ordinance is attached along with a proposed amended 2023 City Budget Ordinance (see attached) as well as the 2023 Expenditure Budget summary and history of expenses for each fund. Also attached are the detailed revenue estimates for 2022 and 2023, in addition to actual revenues for previous years for each fund.

Changes to the 2023 Budget from the first reading to the final reading are as follows:

Revenues increased \$3,962,115

Expenses increased \$6,504,225

The City Council will need to amend the 2023 City Budget Ordinance from the first reading with the proposed amended 2023 City Budget Ordinance prior to adoption of the 2023 City Budget Ordinance.

Fiscal Impact

Source of Funds: N/A

Cost: N/A

Recurring Cost? (Yes/No): N/A

Funds Available in Current Budget? (Yes/No): N/A

Financial Implications:

There is no fiscal impact on the current budget since this is the proposed 2022 Budget.

Attachments

2023 Revenue Budget Estimates
2023 Expense Budget Summary
Ordinance
Ordinance - Amended

ESTIMATED REVENUE BUDGET WORKSHEET
CITY OF HUBER HEIGHTS

	2018 Actual Revenue	2019 Actual Revenue	2020 Actual Revenue	2021 Actual Revenue	2022 Estimated Revenue	2023 Estimated Revenue	\$ incr / (decr) 2023-2022	% incr / (decr) 2023-2022	
GENERAL FUND									
101.000.4100	CITY INCOME TAX	\$6,501,639	\$7,178,812	\$7,075,647	\$8,020,578	\$7,794,532	\$8,922,091	1,127,559	14.47%
101.000.4201	REAL PROPERTY TAX	\$796,572	\$834,841	\$830,077	\$956,837	\$1,081,304	\$1,076,516	(4,788)	-0.44%
101.000.4202	TANGIBLE PROPERTY TAX	\$0	\$0	\$0	\$7	\$0	\$0	-	---
101.000.4203	PUBLIC UTILITY PROPERTY TAX	\$21,935	\$23,238	\$24,977	\$25,409	\$25,500	\$25,500	-	0.00%
101.000.4204	TRAILER TAX	\$0	\$0	\$0	\$0	\$0	\$0	-	---
101.000.4209	PAYMENT IN LIEU OF TAXES	\$0	\$0	\$0	\$0	\$0	\$0	-	---
101.000.4211	HOTEL/MOTEL TAX	\$177,427	\$223,628	\$120,009	\$200,111	\$175,000	\$265,000	90,000	51.43%
101.000.4240	CRA SERVICE PAYMENT - WATERSTONE	\$0	\$51,617	\$187,666	\$187,666	\$187,666	\$187,666	-	0.00%
101.000.4241	CRA SERVICE PAYMENT - DANBURY	\$0	\$0	\$84,036	\$136,220	\$136,220	\$149,476	13,256	9.73%
101.000.4242	CRA SERVICE PAYMENT - PARKVIEW	\$0	\$0	\$0	\$0	\$0	\$92,500	92,500	---
101.000.4243	CRA SERVICE PAYMENT - REDWOOD	\$0	\$0	\$0	\$0	\$0	\$93,333	93,333	---
	CRA SERVICE PAYMENT - DANBURY II	\$0	\$0	\$0	\$0	\$0	\$0	-	---
101.000.4301	LOCAL GOVERNMENT-STATE	\$0	\$66,914	\$147,108	\$183,044	\$168,000	\$245,645	77,645	46.22%
101.000.4305	HOMESTEAD (ROLLBACK)	\$125,153	\$125,195	\$124,904	\$141,111	\$118,659	\$139,700	21,041	17.73%
101.000.4306	10M EXEMPT TAX	\$0	\$0	\$0	\$0	\$0	\$0	-	---
101.000.4307	UTILITY DEREG REIMBURSEMENT	\$0	\$0	\$0	\$0	\$0	\$0	-	---
101.000.4308	LIQUOR PERMITS	\$39,456	\$38,581	\$7,505	\$31,796	\$25,000	\$31,796	6,796	27.18%
101.000.4309	OTHER LICENSE/FEES	\$600	\$0	\$150	\$0	\$500	\$500	-	0.00%
101.000.4311	LOCAL GOVERNMENT-COUNTY	\$440,284	\$458,360	\$457,956	\$516,163	\$475,000	\$653,504	178,504	37.58%
101.000.4314	CIGARETTE TAX	\$1,291	\$1,304	\$487	\$907	\$1,300	\$950	(350)	-26.92%
101.000.4315	ESTATE TAX	\$10	\$17	\$0	\$0	\$0	\$0	-	---
101.000.4321	FEDERAL GRANTS	\$0	\$0	\$0	\$0	\$0	\$0	-	---
101.000.4322	STATE GRANTS	\$0	\$0	\$0	\$0	\$0	\$0	-	---
101.000.4323	COUNTY GRANTS	\$0	\$0	\$0	\$0	\$0	\$0	-	---
101.000.4325	RZEDB INTEREST REBATE	\$124,997	\$118,879	\$112,598	\$105,566	\$100,000	\$89,351	(10,649)	-10.65%
101.000.4326	LOCAL GRANTS	\$0	\$0	\$0	\$0	\$0	\$0	-	---
101.000.4327	MONT. COUNTY LAND BANK GRANT	\$0	\$0	\$0	\$0	\$0	\$0	-	---
101.000.4401	WEED ASSESSMENTS	\$44,286	\$21,335	\$43,693	\$19,263	\$25,000	\$30,000	5,000	20.00%
101.000.4402	PROPERTY MAINTENANCE ASSESSMENTS	\$0	\$0	\$1,594	\$0	\$1,200	\$500	(700)	-58.33%
101.000.4491	OTHER ASSESSMENTS	\$29,101	\$16,787	\$11,224	\$14,180	\$15,000	\$20,000	5,000	33.33%
101.000.4501	DISPATCH FEES	\$370,900	\$381,192	\$389,665	\$399,406	\$409,392	\$419,627	10,235	2.50%
101.000.4502	EMS FEES	\$1,239,273	\$1,369,122	\$1,366,027	\$1,561,242	\$1,400,000	\$1,650,000	250,000	17.86%
101.000.4503	C & DD TIPPING FEE	\$0	\$0	\$0	\$0	\$0	\$0	-	---
101.000.4504	FIRE INSPECTION PERMITS	\$125	\$25	\$25	\$200	\$200	\$250	50	25.00%
101.000.4505	FALSE ALARM FEES	\$9,275	\$0	\$0	\$0	\$0	\$0	-	---
101.000.4506	CPR CLASS FEES	\$2,287	\$2,125	\$673	\$1,605	\$2,000	\$2,000	-	0.00%
101.000.4508	NEIGHBORHOOD WATCH SIGN FEE	\$35	\$0	\$0	\$0	\$35	\$0	(35)	-100.00%
101.000.4509	CIVIL WEDDING FEES	\$1,550	\$1,500	\$900	\$962	\$1,000	\$800	(200)	-20.00%
101.000.4513	RENTAL FEES	\$41,912	\$30,166	\$29,106	\$30,652	\$29,106	\$32,000	2,894	9.94%
101.000.4590	CONTRACT INSPECTION FEES	\$9,899	\$13,957	\$5,586	\$1,859	\$7,000	\$9,000	2,000	28.57%
101.000.4601	ORDINANCE FINES	\$37,779	\$36,997	\$29,142	\$32,787	\$37,000	\$37,000	-	0.00%
101.000.4611	CABLE FRANCHISE FEES	\$464,617	\$468,961	\$479,960	\$476,243	\$480,000	\$480,000	-	0.00%
101.000.4612	DOG LICENSES	\$7,263	\$7,660	\$9,233	\$7,101	\$8,500	\$7,500	(1,000)	-11.76%
101.000.4621	ZONING FEES	\$95,121	\$99,745	\$69,229	\$90,295	\$85,000	\$85,000	-	0.00%
101.000.4622	GRADING PERMITS	\$4,267	\$6,837	\$1,646	\$3,005	\$2,500	\$3,500	1,000	40.00%
101.000.4701	INTEREST INCOME	\$481,583	\$711,702	\$533,679	\$296,452	\$207,516	\$712,000	504,484	243.11%
101.000.4820	CITY ANNIVERSARY ITEMS	\$0	\$0	\$0	\$0	\$0	\$0	-	---
101.000.4830	COMMISSIONS	\$0	\$0	\$0	\$0	\$0	\$0	-	---
101.000.4880	LAND REUTILIZATION	\$0	\$0	\$0	\$0	\$0	\$0	-	---
101.000.4881	HUMANITARIAN RELIEF FUND	\$0	\$7,180	\$0	\$0	\$0	\$0	-	---
101.000.4882	MILITARY HONOR BANNER PROGRAM	\$0	\$1,320	\$1,980	\$2,475	\$2,500	\$1,000	(1,500)	-60.00%
101.000.4883	VETERANS MEMORIAL PROJECT	\$0	\$8,272	\$0	\$5,000	\$5,000	\$0	(5,000)	-100.00%
101.000.4890	AUCTION PROCEEDS (moved to 4909 and 4910)	\$38,610	\$14,754	\$0	\$0	\$0	\$0	-	---

ESTIMATED REVENUE BUDGET WORKSHEET
CITY OF HUBER HEIGHTS

		2018	2019	2020	2021	2022	2023	\$	%
		Actual	Actual	Actual	Actual	Estimated	Estimated	incr / (decr)	incr / (decr)
		Revenue	Revenue	Revenue	Revenue	Revenue	Revenue	2023-2022	2023-2022
101.000.4891	REFUNDS	\$79,572	\$37,788	\$882,232	\$23,575	\$25,000	\$25,000	-	0.00%
101.000.4892	REIMBURSEMENTS	\$2,829	\$2,503	\$3,218	\$1,947	\$3,000	\$3,000	-	0.00%
101.000.4893	DONATIONS	\$11,002	\$5,000	\$0	\$2,350	\$5,000	\$5,000	-	0.00%
101.000.4894	COURT REIMBURSEMENTS	\$83,404	\$44,266	\$84,000	\$71,400	\$85,680	\$89,142	3,462	4.04%
101.000.4898	UNCLAIMED MONEY	\$298	\$655	\$0	\$0	\$500	\$500	-	0.00%
101.000.4899	MISCELLANEOUS REVENUE	\$3,120	\$2,112	\$1,397	\$716	\$2,000	\$2,000	-	0.00%
101.000.4906	LEASE PROCEEDS	\$0	\$0	\$2,038,012	\$0	\$0	\$0	-	---
101.000.4909	SALE OF FIXED ASSETS - CAPITAL	\$1,265,943	\$0	\$8,030	\$13,698	\$20,000	\$20,000	-	0.00%
101.000.4910	SALE OF FIXED ASSETS - NON-CAPITAL	\$0	\$0	\$376	\$3,362	\$5,000	\$5,000	-	0.00%
101.000.4912	OP TRANS FROM SPECIAL REVENUE	\$0	\$0	\$1,706	\$0	\$0	\$0.00	-	---
101.000.4913	OP TRANS FROM DEBT SERVICE	\$0	\$0	\$0	\$0	\$0	\$0	-	---
101.000.4914	OP TRANS FROM CAPITAL PROJECTS	\$0	\$0	\$0	\$0	\$0	\$0	-	---
101.000.4915	OP TRANS FROM ENTERPRISE FUNDS	\$0	\$0	\$0	\$0	\$0	\$0	-	---
101.000.4921	ADVANCES FROM GENERAL FUND	\$0	\$0	\$0	\$0	\$0	\$0	-	---
101.000.4922	ADVANCES FROM SPECIAL REVENUE	\$250,000	\$0	\$0	\$0	\$17,000	\$1,400,000	1,383,000	8135.29%
101.000.4923	ADVANCES FROM DEBT SERVICE	\$0	\$0	\$0	\$0	\$0	\$0	-	---
101.000.4924	ADVANCES FROM CAPITAL PROJECTS	\$0	\$153,750	\$2,633,250	\$0	\$20,000	\$20,000	-	0.00%
101.000.4925	ADVANCES FROM ENTERPRISE FUNDS	\$0	\$0	\$0	\$0	\$0	\$0	-	---
101.000.4926	ADVANCES FROM INTERNAL SERVICE	\$0	\$0	\$0	\$0	\$0	\$0	-	---
101.000.4927	ADVANCES FROM TRUSTS	\$0	\$0	\$0	\$0	\$0	\$0	-	---
101.000.4928	ADVANCES FROM AGENCY	\$0	\$0	\$0	\$0	\$0	\$0	-	---
101.330.4513	RENTAL FEES	\$25	\$1,655	\$0	\$1,900	\$3,000	\$3,000	-	0.00%
101.330.4514	FARMERS MARKET FEES	\$0	\$0	\$2,230	\$3,735	\$5,500	\$5,700	200	3.64%
101.330.4893	DONATIONS	\$900	\$2,350	\$3,500	\$8,425	\$6,000	\$6,000	-	0.00%
101.700.4911	OP TRANS FROM GENERAL FUND - TRANS	\$0	\$0	\$0	\$0	\$0	\$0	-	---
TOTAL FUND 101		\$12,804,338	\$12,571,104	\$17,804,433	\$13,579,250	\$13,204,310	\$17,048,047	3,843,737	29.11%
MOTOR VEHICLE									
202.000.4313	VEHICLE LICENSE TAX	\$276,805	\$279,898	\$301,358	\$346,330	\$332,247	\$346,330	14,083	4.24%
202.000.4321	FEDERAL GRANTS	\$0	\$0	\$0	\$0	\$0	\$0	-	---
202.000.4701	INTEREST INCOME	\$3,517	\$5,490	\$4,891	\$2,594	\$2,400	\$3,139	739	30.79%
202.000.4891	REFUNDS	\$1,197	\$1,516	\$3,000	\$47	\$1,000	\$1,000	-	0.00%
202.000.4892	REIMBURSEMENTS	\$161	\$738	\$429	\$175	\$150	\$150	-	0.00%
202.000.4899	MISCELLANEOUS REVENUE	\$0	\$0	\$0	\$0	\$0	\$0	-	---
202.000.4911	OP TRANS FROM GENERAL FUND	\$0	\$0	\$0	\$0	\$0	\$0	-	---
202.000.4912	OP TRANS FROM SPECIAL REVENUE	\$0	\$0	\$0	\$0	\$0	\$0	-	---
TOTAL FUND 202		\$281,680	\$287,642	\$309,678	\$349,145	\$335,797	\$350,619	14,822	4.41%

ESTIMATED REVENUE BUDGET WORKSHEET
CITY OF HUBER HEIGHTS

	2018 Actual Revenue	2019 Actual Revenue	2020 Actual Revenue	2021 Actual Revenue	2022 Estimated Revenue	2023 Estimated Revenue	\$ incr / (decr) 2023-2022	% incr / (decr) 2023-2022	
GASOLINE TAX									
203.000.4302	GASOLINE TAX	\$1,304,359	\$1,615,490	\$2,011,747	\$2,148,864	\$2,260,198	\$2,155,864	(104,334)	-4.62%
203.000.4303	MUNICIPAL CENTS PER GALLON	\$0	\$0	\$0	\$0	\$0	\$0	-	---
203.000.4321	FEDERAL GRANTS	\$0	\$0	\$0	\$0	\$0	\$0	-	---
203.000.4322	STATE GRANTS	\$0	\$0	\$40,000	\$0	\$0	\$0	-	---
203.000.4411	SIDEWALK ASSESSMENTS	\$494	\$364	\$475	\$353	\$365	\$365	-	0.00%
203.000.4421	STREET ASSESSMENTS	\$3,131	\$2,398	\$3,025	\$2,335	\$2,400	\$2,400	-	0.00%
203.000.4701	INTEREST INCOME	\$19,938	\$23,506	\$27,247	\$5,475	\$7,800	\$8,400	600	7.69%
203.000.4890	AUCTION PROCEEDS	\$0	\$0	\$0	\$0	\$0	\$0	-	---
203.000.4891	REFUNDS	\$3,306	\$4,215	\$8,480	\$126	\$3,500	\$3,500	-	0.00%
203.000.4892	REIMBURSEMENTS	\$872	\$2,169	\$599	\$485	\$500	\$500	-	0.00%
203.000.4899	MISCELLANEOUS REVENUE	\$4,553	\$1,329	\$1,442	\$2,943	\$2,000	\$2,000	-	0.00%
203.000.4909	SALE OF FIXED ASSETS	\$0	\$0	\$0	\$0	\$0	\$0	-	---
203.000.4914	OP TRANS FROM CAPITAL PROJECTS	\$0	\$0	\$0	\$0	\$0	\$0	-	---
203.000.4912	OP TRANS FROM SPECIAL REVENUE - TR	\$0	\$0	\$317	\$0	\$0	\$0	-	---
203.000.4922	ADVANCES FROM SPECIAL REVENUE						\$1,440,725	1,440,725	---
203.000.4924	ADVANCES FROM CAPITAL PROJECTS	\$748,973	\$1,039,144	\$848,851	\$487,175	\$526,832	\$504,484	(22,348)	-4.24%
TOTAL FUND 203		\$2,085,627	\$2,688,614	\$2,942,182	\$2,647,757	\$2,803,595	\$4,118,238	1,314,643	46.89%
LIGHTING DISTRICT									
207.000.4323	COUNTY GRANTS	\$0	\$0	\$0	\$0	\$0	\$0	-	---
207.000.4431	LIGHTING ASSESSMENTS	\$329,941	\$330,039	\$329,447	\$327,617	\$330,000	\$335,000	5,000	1.52%
207.000.4891	REFUNDS	\$140	\$123	\$315	\$4	\$100	\$100	-	0.00%
207.000.4892	REIMBURSEMENTS	\$6	\$24	\$11	\$25	\$8	\$25	17	212.50%
TOTAL FUND 207		\$330,088	\$330,187	\$329,772	\$327,646	\$330,108	\$335,125	5,017	1.52%
POLICE									
209.000.4100	CITY INCOME TAX	\$5,512,632	\$6,084,083	\$6,000,671	\$6,805,879	\$6,610,339	\$7,570,860	960,521	14.53%
209.000.4201	REAL PROPERTY TAX	\$931,327	\$979,061	\$963,422	\$968,144	\$1,120,787	\$1,124,917	4,130	0.37%
209.000.4202	TANGIBLE PROPERTY TAX	\$0	\$0	\$0	\$26	\$0	\$0	-	---
209.000.4203	PUBLIC UTILITY PROPERTY TAX	\$80,531	\$85,441	\$91,852	\$93,461	\$94,000	\$102,000	8,000	8.51%
209.000.4204	TRAILER TAX	\$0	\$0	\$0	\$0	\$0	\$0	-	---
209.000.4305	HOMESTEAD (ROLLBACK)	\$140,507	\$140,516	\$139,516	\$133,654	\$138,500	\$134,000	(4,500)	-3.25%
209.000.4306	10M EXEMPT TAX	\$0	\$0	\$0	\$0	\$0	\$0	-	---
209.000.4307	UTILITY DEREG REIMBURSEMENT	\$0	\$0	\$0	\$0	\$0	\$0	-	---
209.000.4321	FEDERAL GRANTS	\$0	\$2,833	\$6,722	\$4,433	\$3,000	\$3,000	-	0.00%
209.000.4322	STATE GRANTS	\$0	\$0	\$0	\$0	\$0	\$0	-	---
209.000.4323	COUNTY GRANTS	\$0	\$0	\$0	\$0	\$0	\$0	-	---
209.000.4324	PRIVATE GRANTS	\$0	\$0	\$0	\$0	\$0	\$0	-	---
209.000.4512	ACTIVITY FEES	\$0	\$0	\$0	\$0	\$0	\$0	-	---
209.000.4599	OTHER CHARGES FOR SERVICES	\$0	\$0	\$0	\$0	\$0	\$0	-	---
209.000.4701	INTEREST INCOME	\$196	\$141	\$98	\$121	\$100	\$150	50	50.00%
209.000.4890	AUCTION PROCEEDS	\$0	\$0	\$0	\$0	\$0	\$0	-	---
209.000.4891	REFUNDS	\$70,563	\$88,391	\$147,983	\$17,077	\$50,000	\$50,000	-	0.00%
209.000.4892	REIMBURSEMENTS	\$35,498	\$123,483	\$153,066	\$117,067	\$90,000	\$150,000	60,000	66.67%
209.000.4893	DONATIONS	\$0	\$0	\$0	\$0	\$0	\$0	-	---
209.000.4895	SECURITY REIMBURSEMENTS	\$8,875	\$3,747	\$6,884	\$742	\$5,000	\$6,000	1,000	20.00%
209.000.4899	MISCELLANEOUS REVENUE	\$424	\$378	\$256	\$351	\$400	\$400	-	0.00%
209.000.4906	LEASE PROCEEDS	\$172,435	\$0	\$0	\$0	\$0	\$0	-	---
209.000.4909	SALE OF FIXED ASSETS	\$0	\$0	\$0	\$0	\$0	\$0	-	---
209.000.4911	OP TRANS FROM GENERAL FUND	\$800,000	\$500,000	\$700,000	\$0	\$769,000	\$0	(769,000)	-100.00%
209.000.4912	OP TRANS FROM SPECIAL REVENUE	\$0	\$0	\$627,605	\$0	\$0	\$10,000	10,000	---
209.000.4914	OP TRANS FROM CAPITAL PROJECTS	\$0	\$0	\$0	\$0	\$0	\$0	-	---
TOTAL FUND 209		\$7,752,987	\$8,008,073	\$8,838,074	\$8,140,956	\$8,881,126	\$9,151,327	270,201	3.04%

ESTIMATED REVENUE BUDGET WORKSHEET
CITY OF HUBER HEIGHTS

		2018 Actual Revenue	2019 Actual Revenue	2020 Actual Revenue	2021 Actual Revenue	2022 Estimated Revenue	2023 Estimated Revenue	\$ incr / (decr) 2023-2022	% incr / (decr) 2023-2022
FIRE									
210.000.4100	CITY INCOME TAX	\$2,087,724	\$2,301,837	\$2,272,802	\$2,581,429	\$2,503,718	\$2,871,581	367,863	14.69%
210.000.4201	REAL PROPERTY TAX	\$794,388	\$834,433	\$821,414	\$825,465	\$949,695	\$952,826	3,131	0.33%
210.000.4202	TANGIBLE PROPERTY TAX	\$0	\$0	\$0	\$20	\$0	\$0	-	---
210.000.4203	PUBLIC UTILITY PROPERTY TAX	\$62,814	\$66,644	\$71,644	\$72,900	\$73,500	\$77,000	3,500	4.76%
210.000.4204	TRAILER TAX	\$0	\$0	\$0	\$0	\$0	\$0	-	---
210.000.4305	HOMESTEAD (ROLLBACK)	\$120,589	\$120,597	\$119,738	\$114,707	\$119,500	\$119,500	-	0.00%
210.000.4306	10M EXEMPT TAX	\$0	\$0	\$0	\$0	\$0	\$0	-	---
210.000.4307	UTILITY DEREG REIMBURSEMENT	\$0	\$0	\$0	\$0	\$0	\$0	-	---
210.000.4321	FEDERAL GRANTS	\$0	\$0	\$0	\$0	\$0	\$273,547	273,547	---
210.000.4322	STATE GRANTS	\$0	\$0	\$0	\$2,747	\$0	\$2,500	2,500	---
210.000.4324	PRIVATE GRANTS	\$0	\$0	\$0	\$0	\$0	\$0	-	---
210.000.4330	COVID-19	\$0	\$0	\$34,322	\$0	\$0	\$0	-	---
210.000.4513	RENTAL FEES	\$1,644	\$1,644	\$1,644	\$1,644	\$1,644	\$1,644	-	0.00%
210.000.4701	INTEREST INCOME	\$27	\$54	\$37	\$46	\$37	\$37	-	0.00%
210.000.4890	AUCTION PROCEEDS	\$0	\$0	\$0	\$0	\$0	\$0	-	---
210.000.4891	REFUNDS	\$62,909	\$69,496	\$138,496	\$10,459	\$60,000	\$20,000	(40,000)	-66.67%
210.000.4892	REIMBURSEMENTS	\$4,815	\$3,404	\$6,567	\$3,893	\$5,000	\$5,000	-	0.00%
210.000.4893	DONATIONS	\$0	\$1,750	\$3,850	\$100	\$5,000	\$5,000	-	0.00%
210.000.4895	SECURITY REIMBURSEMENTS	\$0	\$0	\$0	\$0	\$0	\$0	-	---
210.000.4899	MISCELLANEOUS REVENUE	\$0	\$0	\$0	\$66	\$0	\$0	-	---
210.000.4906	LEASE PROCEEDS	\$0	\$0	\$0	\$0	\$0	\$0	-	---
210.000.4909	SALE OF FIXED ASSETS	\$0	\$0	\$0	\$0	\$0	\$0	-	---
210.000.4911	OP TRANS FROM GENERAL FUND	\$4,069,882	\$3,800,000	\$4,550,000	\$3,500,000	\$4,950,000	\$4,675,000	(275,000)	-5.56%
210.000.4912	OP TRANS FROM SPECIAL REVENUE	\$41,289	\$17,245	\$1,458,404	\$75,043	\$0	\$56,500	56,500	---
210.000.4914	OP TRANS FROM CAPITAL PROJECTS	\$0	\$0	\$0	\$0	\$0	\$0	-	---
210.000.4924	ADVANCES FROM CAPITAL PROJECTS	\$0	\$0	\$0	\$0	\$0	\$0	-	---
TOTAL FUND 210		\$7,246,081	\$7,217,103	\$9,478,918	\$7,188,520	\$8,668,094	\$9,060,135	392,041	4.52%
DRUG ENFORCEMENT									
211.000.4321	FEDERAL GRANTS	\$0	\$0	\$0	\$0	\$0	\$0	-	---
211.000.4601	ORDINANCE FINES	\$0	\$0	\$0	\$0	\$0	\$0	-	---
211.000.4602	FEDERAL FORFEITURES	\$0	\$0	\$0	\$0	\$0	\$0	-	---
211.000.4603	STATE FORFEITURES	\$0	\$0	\$0	\$0	\$0	\$0	-	---
211.000.4604	DRUG FINES	\$780	\$1,109	\$2,033	\$1,366	\$1,500	\$1,500	-	0.00%
211.000.4890	AUCTION PROCEEDS	\$0	\$0	\$0	\$0	\$0	\$0	-	---
211.000.4892	REIMBURSEMENTS	\$0	\$0	\$0	\$2,001	\$0	\$0	-	---
211.000.4909	SALE OF FIXED ASSETS	\$0	\$0	\$0	\$0	\$0	\$0	-	---
TOTAL FUND 211		\$780	\$1,109	\$2,033	\$3,367	\$1,500	\$1,500	-	0.00%

ESTIMATED REVENUE BUDGET WORKSHEET
CITY OF HUBER HEIGHTS

		2018 Actual Revenue	2019 Actual Revenue	2020 Actual Revenue	2021 Actual Revenue	2022 Estimated Revenue	2023 Estimated Revenue	\$ incr / (decr) 2023-2022	% incr / (decr) 2023-2022
LAW ENFORCEMENT									
212.000.4321	FEDERAL GRANTS	\$0	\$0	\$0	\$0	\$0	\$0	-	---
212.000.4322	STATE GRANTS	\$0	\$0	\$0	\$0	\$0	\$0	-	---
212.000.4601	ORDINANCE FINES	\$1,053	\$1,138	\$3,235	\$3,444	\$3,000	\$3,000	-	0.00%
212.000.4602	FEDERAL FORFEITURES	\$0	\$0	\$0	\$0	\$0	\$0	-	---
212.000.4603	STATE FORFEITURES	\$560	\$14,438	\$67,020	\$15,335	\$15,000	\$15,000	-	0.00%
212.000.4605	PARKING FINES	\$495	\$2,815	\$1,140	\$1,190	\$1,100	\$1,100	-	0.00%
212.000.4890	AUCTION PROCEEDS	\$11,706	\$1,182	\$0	\$0	\$0	\$0	-	---
212.000.4891	REFUNDS	\$0	\$0	\$0	\$0	\$0	\$0	-	---
212.000.4892	REIMBURSEMENTS	\$2,251	\$245	\$39	\$31	\$1,000	\$1,000	-	0.00%
212.000.4893	DONATIONS	\$0	\$0	\$0	\$0	\$0	\$0	-	---
212.000.4899	MISCELLANEOUS REVENUE	\$35	\$140	\$0	\$105	\$100	\$100	-	0.00%
212.000.4909	SALE OF FIXED ASSETS - CAPITAL	\$0	\$0	\$0	\$0	\$0	\$0	-	---
212.000.4910	SALE OF FIXED ASSETS - NON-CAPITAL	\$0	\$0	\$220	\$450	\$2,000	\$500	(1,500)	-75.00%
TOTAL FUND 212		\$16,100	\$19,958	\$71,653	\$20,555	\$22,200	\$20,700	(1,500)	-6.76%
STATE HIGHWAY MAINTENANCE									
214.000.4302	GASOLINE TAX	\$105,759	\$130,986	\$163,115	\$174,232	\$183,259	\$174,232	(9,027)	-4.93%
214.000.4303	MUNICIPAL CENTS PER GALLON	\$0	\$0	\$0	\$0	\$0	\$0	-	---
214.000.4313	VEHICLE LICENSE TAX	\$22,444	\$22,694	\$24,434	\$28,081	\$26,939	\$28,081	1,142	4.24%
214.000.4411	SIDEWALK ASSESSMENTS	\$479	\$484	\$479	\$486	\$485	\$485	-	0.00%
214.000.4421	STREET ASSESSMENTS	\$3,060	\$3,063	\$3,060	\$3,127	\$3,127	\$3,060	(67)	-2.14%
214.000.4701	INTEREST INCOME	\$2,893	\$2,797	\$2,412	\$500	\$780	\$780	-	0.00%
214.000.4891	REFUNDS	\$0	\$0	\$0	\$0	\$0	\$0	-	---
214.000.4892	REIMBURSEMENTS	\$0	\$0	\$0	\$6	\$0	\$0	-	---
214.000.4906	LEASE PROCEEDS	\$0	\$0	\$961,988	\$0	\$0	\$0	-	---
214.000.4924	ADVANCES FROM CAPITAL PROJECTS	\$0	\$0	\$0	\$0	\$0	\$0	-	---
TOTAL FUND 214		\$134,634	\$160,023	\$1,155,488	\$206,432	\$214,590	\$206,638	(7,952)	-3.71%
COUNTY PERMISSIVE TAX									
216.000.4313	VEHICLE LICENSE TAX	\$92,694	\$92,573	\$91,285	\$97,698	\$101,491	\$97,698	(3,793)	-3.74%
216.000.4912	OP TRANS FROM SPECIAL REVENUE	\$0	\$0	\$0	\$0	\$0	\$0	-	---
216.000.4914	OP TRANS FROM CAPITAL PROJECTS	\$0	\$0	\$0	\$0	\$0	\$0	-	---
TOTAL FUND 216		\$92,694	\$92,573	\$91,285	\$97,698	\$101,491	\$97,698	(3,793)	-3.74%
CITY PERMISSIVE TAX									
217.000.4313	VEHICLE LICENSE TAX	\$245,997	\$255,091	\$262,720	\$287,565	\$300,132	\$305,049	4,917	1.64%
TOTAL FUND 217		\$245,997	\$255,091	\$262,720	\$287,565	\$300,132	\$305,049	4,917	1.64%

ESTIMATED REVENUE BUDGET WORKSHEET
CITY OF HUBER HEIGHTS

		2018 Actual Revenue	2019 Actual Revenue	2020 Actual Revenue	2021 Actual Revenue	2022 Estimated Revenue	2023 Estimated Revenue	\$ incr / (decr) 2023-2022	% incr / (decr) 2023-2022
BYRNE MEMORIAL GRANT									
238.000.4321	FEDERAL GRANTS	\$0	\$0	\$0	\$0	\$0	\$0	-	---
238.000.4701	INTEREST INCOME	\$0	\$1	\$0	\$0	\$0	\$0	-	---
238.000.4911	OP TRANS FROM GENERAL FUND	\$0	\$0	\$0	\$0	\$0	\$0	-	---
238.000.4921	ADVANCES FROM GENERAL FUND	\$0	\$0	\$0	\$0	\$0	\$0	-	---
TOTAL FUND 238		\$0	\$1	\$0	\$0	\$0	\$0	-	---
Highway Safety Grant (Not-used)									
239.000.4321		\$0	\$0	\$0	\$0	\$0	\$0	-	---
239.000.4921		\$0	\$0	\$0	\$0	\$0	\$0	-	---
TOTAL FUND 239		\$0	\$0	\$0	\$0	\$0	\$0	-	---
Mont Co TIF MPITIE Fund									
240.000.4201	REAL PROPERTY TAX	\$0	\$0	\$0	\$0	\$0	\$0	-	---
240.000.4220	PILT MONT CTY TIF	\$1,428,294	\$1,845,413	\$1,872,542	\$1,965,850	\$2,005,167	\$2,528,597	523,430	26.10%
240.000.4305	HOMESTEAD (ROLLBACK)	\$154	\$151	\$151	\$133	\$0	\$135	135	---
240.000.4912	OP TRANS FROM SPECIAL REVENUE	\$0	\$0	\$0	\$2,305,892	\$0	\$0	-	---
240.000.4914	OP TRANS FROM CAPITAL PROJECTS	\$0	\$0	\$0	\$0	\$0	\$0	-	---
240.000.4922	ADVANCES FROM SPECIAL REVENUE	\$146,000	\$145,450	\$145,425	\$145,425	\$145,425	\$0	(145,425)	-100.00%
240.000.4924	ADVANCES FROM CAPITAL PROJECTS	\$0	\$0	\$0	\$0	\$0	\$0	-	---
TOTAL FUND 240		\$1,574,448	\$1,991,015	\$2,018,117	\$4,417,299	\$2,150,592	\$2,528,732	378,140	17.58%
FIREFIGHTERS ASSISTANCE GRANT									
241.000.4321	FEDERAL GRANTS	\$0	\$0	\$0	\$0	\$0	\$0	-	---
241.000.4701	INTEREST INCOME	\$0	\$0	\$0	\$0	\$0	\$0	-	---
241.000.4911	OP TRANS FROM GENERAL FUND	\$0	\$0	\$0	\$0	\$0	\$0	-	---
241.000.4912	OP TRANS FROM SPECIAL REVENUE	\$0	\$0	\$0	\$0	\$0	\$0	-	---
241.000.4914	OP TRANS FROM CAPITAL PROJECTS	\$0	\$0	\$0	\$0	\$0	\$0	-	---
241.000.4921	ADVANCES FROM GENERAL FUND	\$0	\$0	\$0	\$0	\$0	\$0	-	---
241.000.4922	ADVANCES FROM SPECIAL REVENUE	\$0	\$0	\$0	\$0	\$0	\$0	-	---
TOTAL FUND 241		\$0	\$0	\$0	\$0	\$0	\$0	-	---
LAW ENFORCEMENT ASSISTANCE									
242.000.4322	STATE GRANTS	\$16,400	\$0	\$0	\$0	\$0	\$0	-	---
242.000.4891	REFUNDS	\$0	\$0	\$0	\$0	\$0	\$0	-	---
TOTAL FUND 242		\$16,400	\$0	\$0	\$0	\$0	\$0	-	---

ESTIMATED REVENUE BUDGET WORKSHEET
CITY OF HUBER HEIGHTS

		2018 Actual Revenue	2019 Actual Revenue	2020 Actual Revenue	2021 Actual Revenue	2022 Estimated Revenue	2023 Estimated Revenue	\$ incr / (decr) 2023-2022	% incr / (decr) 2023-2022
MIAMI CO. TIF - Non-DEC									
243.000.4225	MIAMI CO. TIF, SECT 1, A29	\$0	\$0	\$0	\$8,803	\$8,803	\$28,249	19,446	220.90%
243.000.4226	MIAMI CO. TIF, SECT 2, P48	\$21,112	\$141,024	\$495,258	\$641,334	\$705,467	\$846,561	141,094	20.00%
243.000.4227	MIAMI CO. TIF, SECT 3,	\$0	\$0	\$0	\$0	\$0	\$0	-	---
243.000.4305	HOMESTEAD (ROLLBACK)	\$105,832	\$120,188	\$155,272	\$169,917	\$186,909	\$195,000	8,091	4.33%
243.000.4921	ADVANCES FROM GENERAL FUND	\$0	\$0	\$0	\$0	\$0	\$0	-	---
243.000.4922	ADVANCES FROM SPECIAL REVENUE	\$0	\$0	\$141,500	\$135,149	\$139,814	\$142,014	2,200	1.57%
243.000.4925	ADVANCES FROM ENTERPRISE	\$0	\$0	\$141,500	\$135,149	\$0	\$0	-	---
TOTAL FUND 243		\$126,944	\$261,212	\$933,529	\$1,090,352	\$1,040,993	\$1,211,824	170,831	16.41%
MIAMI CO. TIF - DEC Only									
244.000.4225	MIAMI CO. TIF, SECT 1, A29	\$0	\$0	\$0	\$0	\$0	\$0	-	---
244.000.4226	MIAMI CO. TIF, SECT 2, P48	\$901,693	\$928,320	\$932,354	\$925,928	\$925,928	\$925,928	-	0.00%
244.000.4227	MIAMI CO. TIF, SECT 3,	\$0	\$0	\$0	\$0	\$0	\$0	-	---
244.000.4305	HOMESTEAD (ROLLBACK)	\$0	\$0	\$0	\$0	\$0	\$0	-	---
244.000.4921	ADVANCES FROM GENERAL FUND	\$0	\$0	\$0	\$0	\$0	\$0	-	---
244.000.4922	ADVANCES FROM SPECIAL REVENUE	\$0	\$0	\$0	\$0	\$0	\$0	-	---
244.000.4925	ADVANCES FROM ENTERPRISE	\$0	\$0	\$0	\$0	\$0	\$0	-	---
TOTAL FUND 244		\$901,693	\$928,320	\$932,354	\$925,928	\$925,928	\$925,928	-	0.00%
MIAMI CO. WEST TIF (TRIMBLE)									
245.000.4228	PILT MIAMI COUNTY WEST TIF	\$139,839	\$139,210	\$140,460	\$139,020	\$139,210	\$159,041	19,831	14.25%
245.000.4305	HOMESTEAD (ROLLBACK)	\$0	\$0	\$0	\$0	\$0	\$0	-	---
245.000.4912	OP TRANS FROM SPECIAL REVENUE	\$0	\$0	\$0	\$276,300	\$0	\$0	-	---
245.000.4921	ADVANCES FROM GENERAL FUND	\$0	\$0	\$0	\$0	\$0	\$0	-	---
245.000.4922	ADVANCES FROM SPECIAL REVENUE	\$0	\$0	\$0	\$0	\$0	\$0	-	---
245.000.4925	ADVANCES FROM ENTERPRISE	\$0	\$0	\$0	\$0	\$0	\$0	-	---
TOTAL FUND 245		\$139,839	\$139,210	\$140,460	\$415,320	\$139,210	\$159,041	19,831	14.25%
MONT. CO. CENTRAL TIF (FAMILY DOLLAR)									
246.000.4221	PILT MONT. COUNTY CENTRAL TIF	\$0	\$0	\$10,953	\$52,288	\$11,611	\$25,200	13,589	117.04%
246.000.4305	HOMESTEAD (ROLLBACK)	\$0	\$0	\$0	\$0	\$0	\$0	-	---
246.000.4921	ADVANCES FROM GENERAL FUND	\$0	\$0	\$0	\$0	\$0	\$0	-	---
246.000.4922	ADVANCES FROM SPECIAL REVENUE	\$0	\$0	\$0	\$0	\$0	\$0	-	---
246.000.4925	ADVANCES FROM ENTERPRISE	\$0	\$0	\$0	\$0	\$0	\$0	-	---
TOTAL FUND 246		\$0	\$0	\$10,953	\$52,288	\$11,611	\$25,200	13,589	117.04%
MONT. CO. SOUTH TIF (ALCORE)									
247.000.4222	PILT MONT. COUNTY SOUTH TIF	\$564,734	\$155,895	\$153,598	\$147,831	\$147,831	\$150,541	2,710	1.83%
247.000.4305	HOMESTEAD (ROLLBACK)	\$0	\$0	\$0	\$0	\$0	\$0	-	---
247.000.4912	OP TRANS FROM SPECIAL REVENUE	\$0	\$0	\$0	\$123,000	\$0	\$0	-	---
247.000.4921	ADVANCES FROM GENERAL FUND	\$0	\$0	\$0	\$0	\$0	\$0	-	---
247.000.4922	ADVANCES FROM SPECIAL REVENUE	\$0	\$0	\$0	\$0	\$0	\$0	-	---
247.000.4925	ADVANCES FROM ENTERPRISE	\$0	\$0	\$0	\$0	\$0	\$0	-	---
TOTAL FUND 247		\$564,734	\$155,895	\$153,598	\$270,831	\$147,831	\$150,541	2,710	1.83%
MIAMI CO. NORTH FIREHOUSE TIF									
248.000.4229	PILT MIAMI COUNTY NORTH FIRE TIF	\$61,233	\$61,156	\$60,130	\$59,551	\$60,130	\$60,600	470	0.78%
248.000.4305	HOMESTEAD (ROLLBACK)	\$0	\$0	\$0	\$0	\$0	\$0	-	---
248.000.4921	ADVANCES FROM GENERAL FUND	\$0	\$0	\$0	\$0	\$0	\$0	-	---
248.000.4922	ADVANCES FROM SPECIAL REVENUE	\$0	\$0	\$0	\$0	\$0	\$0	-	---
248.000.4925	ADVANCES FROM ENTERPRISE	\$0	\$0	\$0	\$0	\$0	\$0	-	---
TOTAL FUND 248		\$61,233	\$61,156	\$60,130	\$59,551	\$60,130	\$60,600	470	0.78%

ESTIMATED REVENUE BUDGET WORKSHEET
CITY OF HUBER HEIGHTS

		2018	2019	2020	2021	2022	2023	\$	%
		Actual	Actual	Actual	Actual	Estimated	Estimated	incr / (decr)	incr / (decr)
		Revenue	Revenue	Revenue	Revenue	Revenue	Revenue	2023-2022	2023-2022
MONT. CO. LEXINGTON PLACE TIF									
249.000.4223	PILT MONT. CO. LEXINGTON PLACE TIF	\$0	\$0	\$0	\$215,991	\$230,000	\$223,615	(6,385)	-2.78%
249.000.4305	HOMESTEAD (ROLLBACK)	\$0	\$0	\$0	\$21,837	\$22,000	\$24,000	2,000	9.09%
		\$0	\$0	\$0	\$0	\$0	\$0	-	---
TOTAL FUND 249		\$0	\$0	\$0	\$237,829	\$252,000	\$247,615	(4,385)	-1.74%
ENTERPRISE ZONE ADMIN									
250.000.4629	ADMINISTRATIVE FEES	\$0	\$0	\$0	\$0	\$0	\$0	-	---
TOTAL FUND 250		\$0	\$0	\$0	\$0	\$0	\$0	-	---
FEDERAL GRANTS FEMA									
251.000.4321	FEDERAL GRANTS FEMA	\$41,289	\$17,245	\$44,911	\$75,043	\$0	\$56,500	56,500	---
TOTAL FUND 251		\$41,289	\$17,245	\$44,911	\$75,043	\$0	\$56,500	56,500	---
ONEOHIO OPIOID SETTLEMENT									
280.000.4322	STATE GRANTS	\$0	\$0	\$0	\$0	\$0	\$10,825	10,825	---
280.000.4701	INTEREST INCOME	\$0	\$0	\$0	\$0	\$0	\$0	-	---
TOTAL FUND 280		\$0	\$0	\$0	\$0	\$0	\$10,825	10,825	---
CORONAVIRUS RELIEF									
290.000.4321	FEDERAL GRANTS	\$0	\$0	\$2,233,905	\$0	\$0	\$0	-	---
290.000.4701	INTEREST INCOME	\$0	\$0	\$102	\$0	\$0	\$0	-	---
TOTAL FUND 290		\$0	\$0	\$2,234,007	\$0	\$0	\$0	-	---
AMERICAN RESCUE PLAN ACT									
291.000.4321	FEDERAL GRANTS	\$0	\$0	\$0	\$1,998,336	\$1,998,336	\$0	(1,998,336)	-100.00%
		\$0	\$0	\$0	\$0	\$0	\$0	-	---
TOTAL FUND 291		\$0	\$0	\$0	\$1,998,336	\$1,998,336	\$0	(1,998,336)	-100.00%
SHUTTERED VENUE OPERATORS GRANT									
292.000.4321	FEDERAL GRANTS	\$0	\$0	\$0	\$5,770,054	\$0	\$0	-	---
		\$0	\$0	\$0	\$0	\$0	\$0	-	---
TOTAL FUND 292		\$0	\$0	\$0	\$5,770,054	\$0	\$0	-	---

ESTIMATED REVENUE BUDGET WORKSHEET
CITY OF HUBER HEIGHTS

		2018 Actual Revenue	2019 Actual Revenue	2020 Actual Revenue	2021 Actual Revenue	2022 Estimated Revenue	2023 Estimated Revenue	\$ incr / (decr) 2023-2022	% incr / (decr) 2023-2022
SPECIAL ASSESSMENT BOND RETIRE									
305.000.4411	SIDEWALK ASSESSMENTS	\$568	\$568	\$568	\$545	\$545	\$0	(545)	-100.00%
305.000.4421	STREET ASSESSMENTS	\$701,967	\$736,712	\$789,075	\$940,762	\$940,000	\$990,000	50,000	5.32%
305.000.4441	WATER & SEWER ASSESSMENTS	\$12,103	\$20,157	\$18,867	\$18,064	\$18,000	\$18,000	-	0.00%
305.000.4522	TAP-IN FEES	\$0	\$0	\$0	\$0	\$0	\$0	-	---
305.000.4701	INTEREST INCOME	\$0	\$0	\$0	\$0	\$0	\$0	-	---
305.000.4891	REFUNDS	\$2,290	\$0	\$0	\$0	\$0	\$0	-	---
305.000.4892	REIMBURSEMENTS	\$0	\$0	\$0	\$0	\$0	\$0	-	---
305.000.4899	MISCELLANEOUS REVENUE	\$0	\$0	\$0	\$0	\$0	\$0	-	---
305.000.4901	GO BOND PROCEEDS	\$0	\$0	\$0	\$0	\$0	\$0	-	---
305.000.4902	REVENUE BOND PROCEEDS	\$0	\$0	\$0	\$0	\$0	\$0	-	---
305.000.4903	NOTE PROCEEDS	\$0	\$0	\$0	\$0	\$0	\$0	-	---
305.000.4904	ACCRUED INTEREST	\$0	\$0	\$0	\$0	\$0	\$0	-	---
305.000.4905	PREMIUM OF BOND SALES	\$0	\$0	\$0	\$0	\$0	\$0	-	---
305.000.4907	CAPITALIZED INTEREST	\$0	\$0	\$0	\$0	\$0	\$0	-	---
305.000.4908	LOAN PROCEEDS	\$0	\$0	\$0	\$71,790	\$0	\$0	-	---
305.000.4911	OP TRANS FROM GENERAL FUND	\$0	\$0	\$0	\$0	\$0	\$0	-	---
305.000.4912	OP TRANS FROM SPECIAL REVENUE	\$277,100	\$292,000	\$252,540	\$202,000	\$91,000	\$81,000	(10,000)	-10.99%
305.000.4913	OP TRANS FROM DEBT SERVICE	\$0	\$0	\$0	\$0	\$0	\$0	-	---
305.000.4914	OP TRANS FROM CAPITAL PROJECTS	\$0	\$0	\$0	\$0	\$0	\$0	-	---
305.000.4915	OP TRANS FROM ENTERPRISE FUNDS	\$28,000	\$26,000	\$10,000	\$18,800	\$0	\$0	-	---
305.000.4916	OP TRANS FROM INTERNAL SERVICE	\$0	\$0	\$0	\$0	\$0	\$0	-	---
305.000.4917	OP TRANS FROM TRUSTS	\$0	\$0	\$0	\$0	\$0	\$0	-	---
305.000.4918	OP TRANS FROM AGENCY	\$0	\$0	\$0	\$0	\$0	\$0	-	---
305.000.4922	ADVANCE FROM SPECIAL REVENUE	\$158,200	\$147,600	\$141,805	\$244,930	\$249,460	\$142,030	(107,430)	-43.07%
305.000.4925	ADVANCE FROM ENTERPRISE	\$158,300	\$147,600	\$145,800	\$148,350	\$109,470	\$134,530	25,060	22.89%
TOTAL FUND 305		\$1,338,528	\$1,370,637	\$1,358,655	\$1,645,241	\$1,408,475	\$1,365,560	(42,915)	-3.05%

ESTIMATED REVENUE BUDGET WORKSHEET
CITY OF HUBER HEIGHTS

	2018 Actual Revenue	2019 Actual Revenue	2020 Actual Revenue	2021 Actual Revenue	2022 Estimated Revenue	2023 Estimated Revenue	\$ incr / (decr) 2023-2022	% incr / (decr) 2023-2022	
GENERAL OBLIGATION BOND RETIRE									
308.000.4201	REAL PROPERTY TAX	\$0	\$0	\$0	\$0	\$0	\$0	-	---
308.000.4202	TANGIBLE PROPERTY TAX	\$0	\$0	\$0	\$0	\$0	\$0	-	---
308.000.4203	PUBLIC UTILITY PROPERTY TAX	\$0	\$0	\$0	\$0	\$0	\$0	-	---
308.000.4204	TRAILER TAX	\$0	\$0	\$0	\$0	\$0	\$0	-	---
308.000.4305	HOMESTEAD (ROLLBACK)	\$0	\$0	\$0	\$0	\$0	\$0	-	---
308.000.4306	10M EXEMPT TAX	\$0	\$0	\$0	\$0	\$0	\$0	-	---
308.000.4421	STREET ASSESSMENTS	\$0	\$0	\$0	\$0	\$0	\$0	-	---
308.000.4513	RENTAL FEES	\$107,616	\$135,936	\$0	\$0	\$0	\$0	-	---
308.000.4701	INTEREST INCOME	\$0	\$0	\$0	\$0	\$0	\$0	-	---
308.000.4890	AUCTION PROCEEDS	\$0	\$0	\$0	\$0	\$0	\$0	-	---
308.000.4891	REFUNDS	\$960	\$0	\$0	\$1,500	\$0	\$0	-	---
308.000.4892	REIMBURSEMENTS	\$0	\$0	\$0	\$0	\$0	\$0	-	---
308.000.4893	DONATIONS	\$0	\$0	\$0	\$0	\$0	\$0	-	---
308.000.4899	MISCELLANEOUS REVENUE	\$0	\$0	\$0	\$0	\$0	\$0	-	---
308.000.4901	GO BOND PROCEEDS	\$0	\$0	\$0	\$6,075,000	\$0	\$0	-	---
308.000.4903	NOTE PROCEEDS	\$0	\$0	\$0	\$0	\$0	\$0	-	---
308.000.4904	ACCRUED INTEREST	\$0	\$0	\$0	\$0	\$0	\$0	-	---
308.000.4905	PREMIUM OF BOND SALES	\$0	\$0	\$1,891	\$1,000,378	\$0	\$0	-	---
308.000.4907	CAPITALIZED INTEREST	\$0	\$0	\$0	\$0	\$0	\$0	-	---
308.000.4911	OP TRANS FROM GENERAL FUND	\$32,000	\$0	\$51,000	\$271,702	\$323,887	\$323,886	(1)	0.00%
308.000.4912	OP TRANS FROM SPECIAL REVENUE	\$2,364,275	\$2,237,195	\$2,329,500	\$2,605,328	\$2,469,264	\$2,452,864	(16,400)	-0.66%
308.000.4913	OP TRANS FROM DEBT SERVICE	\$0	\$0	\$0	\$0	\$0	\$0	-	---
308.000.4914	OP TRANS FROM CAPITAL PROJECTS	\$172,644	\$0	\$0	\$0	\$0	\$0	-	---
308.000.4915	OP TRANS FROM ENTERPRISE FUNDS	\$75,000	\$67,000	\$78,000	\$74,000	\$73,000	\$75,400	2,400	3.29%
TOTAL FUND 308		\$2,752,495	\$2,440,131	\$2,460,391	\$10,027,908	\$2,866,151	\$2,852,150	(14,001)	-0.49%

ESTIMATED REVENUE BUDGET WORKSHEET
CITY OF HUBER HEIGHTS

	2018 Actual Revenue	2019 Actual Revenue	2020 Actual Revenue	2021 Actual Revenue	2022 Estimated Revenue	2023 Estimated Revenue	\$ incr / (decr) 2023-2022	% incr / (decr) 2023-2022	
CAPITAL IMPROVEMENTS									
406.000.4213	9-1-1 WIRELESS FEES	\$199,392	\$243,054	\$204,502	\$199,759	\$180,000	\$200,000	20,000	11.11%
406.000.4312	PERMISSIVE TAX-COUNTY	\$180,000	\$98,125	\$0	\$0	\$0	\$0	-	---
406.000.4321	FEDERAL GRANTS	\$0	\$0	\$0	\$0	\$0	\$0	-	---
406.000.4322	STATE GRANTS	\$340,606	\$611,047	\$53,138	\$0	\$0	\$0	-	---
406.000.4323	COUNTY GRANTS	\$82,564	\$0	\$0	\$107,508	\$0	\$78,800	78,800	---
406.000.4411	SIDEWALK ASSESSMENTS	\$132,187	\$130,000	\$121,327	\$131,322	\$130,000	\$130,000	-	0.00%
406.000.4421	STREET ASSESSMENTS	\$0	\$0	\$0	\$0	\$0	\$0	-	---
406.000.4441	WATER & SEWER ASSESSMENTS	\$10,176	\$10,176	\$10,204	\$10,231	\$10,176	\$10,231	55	0.54%
406.000.4513	RENTAL FEES	\$0	\$0	\$0	\$0	\$0	\$0	-	---
406.000.4701	INTEREST INCOME	\$0	\$0	\$0	\$0	\$0	\$0	-	---
406.000.4890	AUCTION PROCEEDS	\$0	\$0	\$0	\$0	\$0	\$0	-	---
406.000.4891	REFUNDS	\$277	\$0	\$2,535	\$63	\$0	\$0	-	---
406.000.4892	REIMBURSEMENTS	\$12,494	\$0	\$78	\$86	\$0	\$0	-	---
406.000.4893	DONATIONS	\$0	\$0	\$0	\$0	\$0	\$0	-	---
406.000.4899	MISCELLANEOUS REVENUE	\$0	\$75,000	\$0	\$0	\$75,000	\$0	(75,000)	-100.00%
406.000.4901	GO BOND PROCEEDS	\$0	\$0	\$0	\$8,110,000	\$0	\$0	-	---
406.000.4903	NOTE PROCEEDS	\$7,900,000	\$0	\$0	\$0	\$0	\$0	-	---
406.000.4905	PREMIUM OF BOND SALES	\$0	\$0	\$0	\$920,093	\$0	\$0	-	---
406.000.4906	LEASE PROCEEDS	\$0	\$0	\$0	\$0	\$0	\$0	-	---
406.000.4907	CAPITALIZED INTEREST	\$0	\$0	\$0	\$0	\$0	\$0	-	---
406.000.4908	SIB LOAN PROCEEDS	\$0	\$0	\$0	\$0	\$0	\$0	-	---
406.000.4909	SALE OF FIXED ASSETS	\$0	\$0	\$0	\$0	\$0	\$0	-	---
406.000.4911	OP TRANS FROM GENERAL FUND	\$45,590	\$45,590	\$45,590	\$45,590	\$45,590	\$95,590	50,000	109.67%
406.000.4912	OP TRANS FROM SPECIAL REVENUE	\$1,470,210	\$1,178,265	\$1,314,910	\$1,197,133	\$791,785	\$2,271,485	1,479,700	186.88%
406.000.4914	OP TRANS FROM CAPITAL PROJECTS	\$0	\$0	\$0	\$0	\$0	\$0	-	---
406.000.4915	OP TRANS FROM ENTERPRISE FUNDS	\$421,493	\$361,655	\$0	\$0	\$0	\$0	-	---
406.000.4921	ADVANCES FROM GENERAL FUND	\$0	\$0	\$1,000,000	\$0	\$0	\$1,550,000	1,550,000	---
406.000.4922	ADVANCES FROM SPECIAL REVENUE	\$563,507	\$0	\$116,000	\$0	\$0	\$0	-	---
406.000.4924	ADVANCES FROM CAPITAL PROJECTS	\$332	\$0	\$0	\$0	\$0	\$0	-	---
TOTAL FUND 406		\$11,358,827	\$2,752,912	\$2,868,284	\$10,721,785	\$1,232,551	\$4,336,106	3,103,555	251.80%
TED - TRANSFORMATIVE ECONOMIC DEVELOPMENT									
410.000.4323	COUNTY GRANTS	\$0	\$0	\$0	\$0	\$0	\$0	-	---
410.000.4513	RENTAL FEES	\$0	\$0	\$67,242	\$233,992	\$200,000	\$200,000	-	0.00%
410.000.4891	REFUNDS	\$0	\$0	\$0	\$0	\$0	\$0	-	---
410.000.4892	REIMBURSEMENTS	\$0	\$0	\$128,656	\$285	\$0	\$0	-	---
410.000.4903	NOTE PROCEEDS	\$0	\$3,750,000	\$11,555,000	\$11,555,000	\$11,974,500	\$8,224,500	(3,750,000)	-31.32%
410.000.4905	PREMIUM OF BOND SALES	\$0	\$0	\$31,172	\$109,145	\$0	\$0	-	---
410.000.4909	SALE OF FIXED ASSETS	\$0	\$189,383	\$300,000	\$600,000	\$3,753,000	\$3,753,000	-	0.00%
410.000.4911	OP TRANS FROM GENERAL FUND	\$0	\$1,265,943	\$0	\$0	\$0	\$0	-	---
410.000.4912	OP TRANS FROM SPECIAL REVENUE	\$0	\$0	\$0	\$0	\$107,000	\$0	(107,000)	-100.00%
410.000.4921	ADVANCES FROM GENERAL FUND	\$0	\$0	\$2,602,000	\$0	\$0	\$0	-	---
TOTAL FUND 410		\$0	\$5,205,326	\$14,684,069	\$12,498,422	\$16,034,500	\$12,177,500	(3,857,000)	-24.05%
419.000.4312		\$0	\$0	\$0	\$0	\$0	\$0	-	---
419.000.4911		\$0	\$0	\$0	\$0	\$0	\$0	-	---
419.000.4914		\$0	\$0	\$0	\$0	\$0	\$0	-	---
419.000.4921		\$0	\$0	\$0	\$0	\$0	\$0	-	---
TOTAL FUND 419		\$0	\$0	\$0	\$0	\$0	\$0	-	---

ESTIMATED REVENUE BUDGET WORKSHEET
CITY OF HUBER HEIGHTS

	2018 Actual Revenue	2019 Actual Revenue	2020 Actual Revenue	2021 Actual Revenue	2022 Estimated Revenue	2023 Estimated Revenue	\$ incr / (decr) 2023-2022	% incr / (decr) 2023-2022	
ISSUE 2									
421.000.4312	PERMISSIVE TAX-COUNTY	\$0	\$0	\$0	\$0	\$0	\$0	-	---
421.000.4321	FEDERAL GRANTS	\$0	\$0	\$0	\$0	\$0	\$0	-	---
421.000.4322	STATE GRANTS	\$199,903	\$0	\$0	\$250,000	\$0	\$0	-	---
421.000.4323	COUNTY GRANTS	\$0	\$0	\$0	\$0	\$0	\$0	-	---
421.000.4411	SIDEWALK ASSESSMENTS	\$0	\$0	\$0	\$0	\$0	\$0	-	---
421.000.4421	STREET ASSESSMENTS	\$0	\$0	\$0	\$0	\$0	\$0	-	---
421.000.4701	INTEREST INCOME	\$0	\$0	\$0	\$0	\$0	\$0	-	---
421.000.4890	AUCTION PROCEEDS	\$0	\$0	\$0	\$0	\$0	\$0	-	---
421.000.4891	REFUNDS	\$0	\$0	\$0	\$0	\$0	\$0	-	---
421.000.4892	REIMBURSEMENTS	\$0	\$0	\$0	\$0	\$0	\$0	-	---
421.000.4893	DONATIONS	\$0	\$0	\$0	\$0	\$0	\$0	-	---
421.000.4899	MISCELLANEOUS REVENUE	\$0	\$0	\$0	\$0	\$0	\$0	-	---
421.000.4901	GO BOND PROCEEDS	\$0	\$0	\$0	\$0	\$0	\$0	-	---
421.000.4903	NOTE PROCEEDS	\$0	\$0	\$0	\$0	\$0	\$0	-	---
421.000.4908	LOAN PROCEEDS	\$0	\$0	\$0	\$0	\$0	\$0	-	---
421.000.4911	OP TRANS FROM GENERAL FUND	\$0	\$0	\$0	\$0	\$0	\$0	-	---
421.000.4912	OP TRANS FROM SPECIAL REVENUE	\$0	\$0	\$400,000	\$0	\$0	\$0	-	---
421.000.4914	OP TRANS FROM CAPITAL PROJECTS	\$0	\$0	\$0	\$0	\$0	\$0	-	---
421.000.4915	OP TRANS FROM ENTERPRISE FUNDS	\$0	\$0	\$0	\$0	\$0	\$0	-	---
421.000.4921	ADVANCES FROM GENERAL FUND	\$0	\$0	\$0	\$0	\$0	\$0	-	---
421.000.4922	ADVANCES FROM SPECIAL REVENUE	\$0	\$0	\$500,000	\$0	\$0	\$0	-	---
421.000.4924	ADVANCES FROM CAPITAL PROJECTS	\$0	\$0	\$0	\$0	\$0	\$0	-	---
TOTAL FUND 421		\$199,903	\$0	\$900,000	\$250,000	\$0	\$0	-	---
ED/GE CAPITAL IMPROVEMENT									
427.000.4321	FEDERAL GRANTS	\$0	\$0	\$0	\$0	\$0	\$0	-	---
427.000.4322	STATE GRANTS	\$0	\$0	\$0	\$0	\$0	\$0	-	---
427.000.4323	COUNTY GRANTS	\$0	\$153,750	\$31,250	\$0	\$20,000	\$20,000	-	0.00%
427.000.4421	STREET ASSESSMENTS	\$0	\$0	\$0	\$0	\$0	\$0	-	---
427.000.4701	INTEREST INCOME	\$0	\$0	\$0	\$0	\$0	\$0	-	---
427.000.4892	REIMBURSEMENTS	\$0	\$0	\$0	\$0	\$0	\$0	-	---
427.000.4893	DONATIONS	\$0	\$0	\$0	\$0	\$0	\$0	-	---
427.000.4899	MISCELLANEOUS REVENUE	\$0	\$0	\$0	\$0	\$0	\$0	-	---
427.000.4903	NOTE PROCEEDS	\$0	\$0	\$0	\$0	\$0	\$0	-	---
427.000.4905	PREMIUM OF BOND SALES	\$0	\$0	\$0	\$0	\$0	\$0	-	---
427.000.4909	SALE OF FIXED ASSETS	\$0	\$0	\$0	\$0	\$0	\$0	-	---
427.000.4911	OP TRANS FROM GENERAL FUND	\$0	\$0	\$0	\$0	\$0	\$0	-	---
427.000.4912	OP TRANS FROM SPECIAL REVENUE	\$0	\$0	\$0	\$0	\$0	\$0	-	---
427.000.4914	OP TRANS FROM CAPITAL PROJECTS	\$0	\$0	\$0	\$0	\$0	\$0	-	---
427.000.4921	ADVANCES FROM GENERAL FUND	\$80,000	\$0	\$0	\$0	\$0	\$0	-	---
TOTAL FUND 427		\$80,000	\$153,750	\$31,250	\$0	\$20,000	\$20,000	-	0.00%

ESTIMATED REVENUE BUDGET WORKSHEET
CITY OF HUBER HEIGHTS

		2018	2019	2020	2021	2022	2023	\$	%
		Actual	Actual	Actual	Actual	Estimated	Estimated	incr / (decr)	incr / (decr)
		Revenue	Revenue	Revenue	Revenue	Revenue	Revenue	2023-2022	2023-2022
FIRE CAPITAL/EQUIPMENT									
431.000.4100	CITY INCOME TAX	\$364,388	\$402,740	\$396,589	\$448,891	\$436,882	\$499,346	62,464	14.30%
431.000.4101	CITY INCOME TAX - FIRE STATION	\$0	\$0	\$0	\$0	\$0	\$0	-	---
431.000.4322	STATE GRANTS	\$0	\$0	\$3,448	\$0	\$0	\$0	-	---
431.000.4701	INTEREST INCOME	\$5	\$9	\$6	\$10	\$6	\$6	-	0.00%
431.000.4891	REFUNDS	\$4	\$0	\$0	\$46	\$46	\$46	-	0.00%
431.000.4892	REIMBURSEMENTS	\$0	\$0	\$0	\$0	\$0	\$0	-	---
431.000.4893	DONATIONS	\$0	\$0	\$0	\$0	\$0	\$0	-	---
431.000.4901	GO BOND PROCEEDS	\$0	\$0	\$0	\$0	\$0	\$2,054,500	2,054,500	---
431.000.4903	NOTE PROCEEDS	\$0	\$0	\$0	\$0	\$0	\$0	-	---
431.000.4905	PREMIUM OF BOND SALES	\$0	\$0	\$0	\$0	\$0	\$0	-	---
431.000.4906	LEASE PROCEEDS	\$0	\$0	\$0	\$615,864	\$265,000	\$1,765,000	1,500,000	566.04%
431.000.4909	SALE OF FIXED ASSETS	\$0	\$4,500	\$0	\$0	\$0	\$0	-	---
431.000.4912	OP TRANS FROM SPECIAL REVENUE	\$0	\$60,000	\$60,000	\$65,900	\$59,550	\$44,460	(15,090)	-25.34%
431.000.4914	OP TRANS FROM CAPITAL PROJECTS	\$0	\$0	\$0	\$205,543	\$15,386	\$0	(15,386)	-100.00%
431.000.4922	ADVANCES FROM SPECIAL REVENUE	\$0	\$0	\$0	\$0	\$0	\$0	-	---
431.000.4924	ADVANCES FROM CAPITAL PROJECTS	\$16,141	\$216,846	\$0	\$0	\$0	\$0	-	---
TOTAL FUND 431		\$380,537	\$684,095	\$460,043	\$1,336,254	\$776,870	\$4,363,358	3,586,488	461.66%
LOCAL STREET CAPITAL IMPROVEME									
433.000.4100	CITY INCOME TAX	\$1,610,805	\$1,778,698	\$1,753,316	\$1,987,148	\$1,931,453	\$2,210,504	279,051	14.45%
433.000.4321	FEDERAL GRANTS	\$0	\$0	\$0	\$0	\$0	\$0	-	---
433.000.4323	COUNTY GRANTS	\$0	\$70,000	\$0	\$0	\$0	\$0	-	---
433.000.4701	INTEREST INCOME	\$20	\$41	\$29	\$35	\$25	\$70	45	180.00%
433.000.4892	REIMBURSEMENTS	\$0	\$0	\$0	\$0	\$0	\$0	-	---
433.000.4891	REFUNDS	\$7	\$4,507	\$0	\$207	\$207	\$207	-	0.00%
433.000.4899	MISCELLANEOUS REVENUE	\$0	\$0	\$0	\$0	\$0	\$0	-	---
433.000.4901	GO BOND PROCEEDS	\$0	\$0	\$0	\$0	\$0	\$0	-	---
433.000.4911	OP TRANS FROM GENERAL FUND	\$0	\$0	\$0	\$0	\$0	\$0	-	---
433.000.4912	OP TRANS FROM SPECIAL REVENUE	\$0	\$0	\$0	\$0	\$0	\$250,000	250,000	---
433.000.4914	OP TRANS FROM CAPITAL PROJECTS	\$0	\$0	\$0	\$0	\$0	\$0	-	---
433.000.4924	ADVANCES FROM CAPITAL PROJECTS	\$199,903	\$0	\$0	\$0	\$0	\$0	-	---
TOTAL FUND 433		\$1,810,735	\$1,853,246	\$1,753,344	\$1,987,390	\$1,931,685	\$2,460,781	529,096	27.39%
FEDERAL EQUITY SHARING									
434.000.4321	FEDERAL GRANTS	\$0	\$0	\$0	\$0	\$0	\$0	-	---
434.000.4602	FEDERAL FORFEITURES	\$16,074	\$73,588	\$25,059	\$16,798	\$20,000	\$30,000	10,000	50.00%
434.000.4701	INTEREST INCOME	\$597	\$1,485	\$1,537	\$755	\$800	\$1,200	400	50.00%
434.000.4909	SALE OF FIXED ASSETS	\$0	\$0	\$0	\$0	\$0	\$0	-	---
TOTAL FUND 434		\$16,671	\$75,073	\$26,596	\$17,554	\$20,800	\$31,200	10,400	50.00%
LOCAL LAW ENF BLK GRANT									
435.000.4321	FEDERAL GRANTS	\$0	\$0	\$0	\$0	\$0	\$0	-	---
435.000.4323	COUNTY GRANTS	\$0	\$0	\$0	\$0	\$0	\$0	-	---
435.000.4701	INTEREST INCOME	\$0	\$0	\$0	\$0	\$0	\$0	-	---
435.000.4912	OP TRANS FROM SPECIAL REVENUE	\$0	\$0	\$0	\$0	\$0	\$0	-	---
435.000.4914	OP TRANS FROM CAPITAL PROJECTS	\$0	\$0	\$0	\$0	\$0	\$0	-	---
TOTAL FUND 435		\$0	\$0	\$0	\$0	\$0	\$0	-	---

ESTIMATED REVENUE BUDGET WORKSHEET
CITY OF HUBER HEIGHTS

	2018 Actual Revenue	2019 Actual Revenue	2020 Actual Revenue	2021 Actual Revenue	2022 Estimated Revenue	2023 Estimated Revenue	\$ incr / (decr) 2023-2022	% incr / (decr) 2023-2022
ASSISTANCE TO FF GRANT								
436.000.4321	FEDERAL GRANTS	\$0	\$216,846	\$0	\$205,543	\$15,386	\$0	(15,386) -100.00%
436.000.4911	OP TRANS FROM GENERAL FUND	\$0	\$0	\$0	\$0	\$0	\$0	- ---
436.000.4914	OP TRANS FROM CAPITAL PROJECTS	\$21,684	\$0	\$0	\$0	\$0	\$0	- ---
436.000.4921	ADVANCES FROM GENERAL FUND	\$0	\$0	\$0	\$0	\$0	\$0	- ---
436.000.4924	ADVANCES FROM CAPITAL PROJECTS	\$216,846	\$0	\$0	\$0	\$0	\$0	- ---
TOTAL FUND 436		\$238,530	\$216,846	\$0	\$205,543	\$15,386	\$0	(15,386) -100.00%
ENERGY CONSERV GRANT								
437.000.4321	FEDERAL GRANTS	\$0	\$0	\$0	\$0	\$0	\$0	- ---
437.000.4701	INTEREST INCOME	\$25	\$36	\$26	\$1	\$20	\$0	(20) -100.00%
437.000.4891	REFUNDS	\$0	\$0	\$0	\$0	\$0	\$0	- ---
TOTAL FUND 437		\$25	\$36	\$26	\$1	\$20	\$0	(20) -100.00%
PAE ACQUISITION								
450.000.4701	INTEREST INCOME	\$0	\$0	\$0	\$0	\$0	\$0	- ---
450.000.4901	GO BOND PROCEEDS	\$0	\$0	\$0	\$0	\$0	\$0	- ---
450.000.4903	NOTE PROCEEDS	\$0	\$0	\$0	\$0	\$0	\$0	- ---
TOTAL FUND 450		\$0	\$0	\$0	\$0	\$0	\$0	- ---
CARRIAGE TRAILS INFRASTRUCTURE								
454.000.4701	INTEREST INCOME	\$9	\$21	\$7	\$0	\$10	\$0	(10) -100.00%
454.000.4891	REFUNDS	\$0	\$0	\$0	\$0	\$0	\$0	- ---
454.000.4899	MISCELLANEOUS REVENUE	\$0	\$0	\$0	\$0	\$0	\$0	- ---
454.000.4901	GO BOND PROCEEDS	\$0	\$0	\$0	\$0	\$0	\$0	- ---
454.000.4903	NOTE PROCEEDS	\$0	\$0	\$0	\$0	\$0	\$0	- ---
454.000.4905	PREMIUM OF BOND SALES	\$0	\$0	\$0	\$0	\$0	\$0	- ---
454.000.4908	SIB LOAN PROCEEDS	\$0	\$1,039,144	\$693,851	\$121,175	\$500,000	\$500,000	- 0.00%
454.000.4909	SALE OF FIXED ASSETS	\$0	\$0	\$0	\$0	\$0	\$0	- ---
454.000.4912	OP TRANSFER FROM SPECIAL REVENUE	\$0	\$0	\$0	\$200,000	\$0	\$0	- ---
454.000.4913	OP TRANSFER FROM DEBT SERVICE	\$0	\$0	\$0	\$0	\$0	\$0	- ---
454.000.4922	ADVANCES FROM SPECIAL REVENUE	\$0	\$2,381,000	\$640,000	\$0	\$0	\$0	- ---
454.000.4925	ADVANCES FROM ENTERPRISE FUNDS	\$0	\$0	\$0	\$0	\$0	\$0	- ---
TOTAL FUND 454		\$9	\$3,420,165	\$1,333,858	\$321,175	\$500,010	\$500,000	(10) 0.00%

ESTIMATED REVENUE BUDGET WORKSHEET
CITY OF HUBER HEIGHTS

	2018 Actual Revenue	2019 Actual Revenue	2020 Actual Revenue	2021 Actual Revenue	2022 Estimated Revenue	2023 Estimated Revenue	\$ incr / (decr) 2023-2022	% incr / (decr) 2023-2022
WATER FUND								
501.000.4322	STATE GRANTS	\$0	\$0	\$0	\$0	\$0	-	---
501.000.4441	WATER & SEWER ASSESSMENTS	\$3,337	\$2,009	\$7,475	\$2,988	\$2,700	\$7,820	5,120 189.63%
501.000.4513	RENTAL FEES	\$5,895	\$5,265	\$3,721	\$4,940	\$5,915	\$5,915	- 0.00%
501.000.4520	WATER CHARGES	\$4,441,432	\$5,244,777	\$6,027,331	\$6,161,560	\$6,399,791	\$7,354,119	954,328 14.91%
501.000.4522	TAP-IN FEES	\$170,400	\$166,500	\$183,400	\$217,150	\$180,000	\$150,000	(30,000) -16.67%
501.000.4523	CONTRIBUTIONS IN CAPITAL	\$0	\$0	\$0	\$0	\$0	\$0	- ---
501.000.4590	CONTRACT INSPECTION FEES	\$47,159	\$74,892	\$37,610	\$9,874	\$35,000	\$50,000	15,000 42.86%
501.000.4599	OTHER CHARGES FOR SERVICES	\$95,936	\$103,904	\$77,964	\$71,624	\$75,000	\$75,000	- 0.00%
501.000.4701	INTEREST INCOME	\$68,195	\$71,472	\$60,341	\$34,850	\$30,000	\$43,562	13,562 45.21%
501.000.4890	AUCTION PROCEEDS	\$0	\$77	\$0	\$0	\$0	\$0	- ---
501.000.4891	REFUNDS	-\$20,022	-\$2,991	\$35,618	\$14,540	\$8,000	\$15,000	7,000 87.50%
501.000.4892	REIMBURSEMENTS	\$11,773	\$26,802	\$3,128	\$4,606	\$8,000	\$4,000	(4,000) -50.00%
501.000.4893	DONATIONS	\$0	\$0	\$0	\$0	\$0	\$0	- ---
501.000.4899	MISCELLANEOUS REVENUE	\$0	\$261	\$0	\$0	\$200	\$0	(200) -100.00%
501.000.4908	LOAN PROCEEDS	\$2,255,292	\$7,442,653	\$5,242,291	\$0	\$2,450,000	\$2,000,000	(450,000) -18.37%
501.000.4909	SALE OF FIXED ASSETS - CAPITAL	\$0	\$122,460	\$82,609	\$172,875	\$0	\$0	- ---
501.000.4910	SALE OF FIXED ASSETS - NON-CAPITAL	\$0	\$0	\$0	\$0	\$0	\$0	- ---
501.000.4915	OP TRANS FROM ENTERPRISE FUNDS	\$0	\$0	\$0	\$0	\$0	\$0	- ---
501.000.4924	ADVANCES FROM CAPITAL PROJECTS	\$0	\$0	\$0	\$0	\$0	\$0	- ---
501.000.4925	ADVANCES FROM ENTERPRISE FUNDS	\$0	\$0	\$0	\$0	\$0	\$0	- ---
TOTAL FUND 501		\$7,079,396	\$13,258,080	\$11,761,487	\$6,695,007	\$9,194,606	\$9,705,416	510,810 5.56%
WATER CONSTRUCTION FUND								
502.000.4322	STATE GRANTS	\$0	\$0	\$0	\$0	\$0	\$0	- ---
502.000.4701	INTEREST INCOME	\$0	\$0	\$0	\$0	\$0	\$0	- ---
502.000.4891	REFUNDS	\$0	\$0	\$0	\$0	\$0	\$0	- ---
502.000.4901	GO BOND PROCEEDS	\$0	\$0	\$0	\$0	\$0	\$0	- ---
502.000.4902	REVENUE BOND PROCEEDS	\$0	\$0	\$0	\$0	\$0	\$0	- ---
502.000.4903	NOTE PROCEEDS	\$0	\$0	\$0	\$0	\$0	\$0	- ---
502.000.4905	PREMIUM OF BOND SALES	\$0	\$0	\$0	\$0	\$0	\$0	- ---
502.000.4907	CAPITALIZED INTEREST	\$0	\$0	\$0	\$0	\$0	\$0	- ---
502.000.4911	OP TRANS FROM GENERAL FUND	\$0	\$0	\$0	\$0	\$0	\$0	- ---
502.000.4914	OP TRANS FROM CAPITAL PROJECTS	\$0	\$0	\$0	\$0	\$0	\$0	- ---
502.000.4915	OP TRANS FROM ENTERPRISE FUNDS	\$0	\$0	\$0	\$0	\$0	\$0	- ---
TOTAL FUND 502		\$0	\$0	\$0	\$0	\$0	\$0	- ---
WATER R & I FUND								
503.000.4322	STATE GRANTS	\$0	\$0	\$0	\$0	\$0	\$0	- ---
503.000.4701	INTEREST INCOME	\$6,413	\$9,077	\$6,711	\$3,410	\$5,500	\$0	(5,500) -100.00%
503.000.4892	REIMBURSEMENTS	\$0	\$0	\$0	\$0	\$0	\$0	- ---
503.000.4911	OP TRANS FROM GENERAL FUND	\$0	\$0	\$0	\$0	\$0	\$0	- ---
503.000.4915	OP TRANS FROM ENTERPRISE FUNDS	\$72,000	\$72,000	\$72,000	\$62,000	\$0	\$0	- ---
TOTAL FUND 503		\$78,413	\$81,077	\$78,711	\$65,410	\$5,500	\$0	(5,500) -100.00%

ESTIMATED REVENUE BUDGET WORKSHEET
CITY OF HUBER HEIGHTS

	2018 Actual Revenue	2019 Actual Revenue	2020 Actual Revenue	2021 Actual Revenue	2022 Estimated Revenue	2023 Estimated Revenue	\$ incr / (decr) 2023-2022	% incr / (decr) 2023-2022
WATER UTILITY RESERVE								
504.000.4321	FEDERAL GRANTS	\$0	\$0	\$0	\$0	\$0	-	---
504.000.4322	STATE GRANTS	\$0	\$0	\$250,000	\$0	\$200,000	\$500,000	300,000 150.00%
504.000.4441	WATER & SEWER ASSESSMENTS	\$0	\$0	\$0	\$0	\$0	\$0	-
504.000.4701	INTEREST INCOME	\$30,801	\$51,110	\$27,338	\$9,549	\$18,000	\$0	(18,000) -100.00%
504.000.4899	MISCELLANEOUS REVENUE	\$0	\$0	\$0	\$0	\$0	\$0	-
504.000.4901	GO BOND PROCEEDS	\$0	\$0	\$0	\$0	\$0	\$0	-
504.000.4909	SALE OF FIXED ASSETS	\$0	\$0	\$0	\$0	\$0	\$0	-
504.000.4911	OP TRANS FROM GENERAL FUND	\$0	\$0	\$0	\$0	\$0	\$0	-
504.000.4912	OP TRANS FROM SPECIAL REVENUE	\$0	\$0	\$0	\$120,000	\$3,876,672	\$3,892,628	15,956 0.41%
504.000.4915	OP TRANS FROM ENTERPRISE FUNDS	\$2,894,272	\$7,614,189	\$5,103,733	\$930,310	\$4,642,167	\$1,708,600	(2,933,567) -63.19%
504.000.4921	ADVANCES FROM GENERAL FUND	\$0	\$0	\$0	\$0	\$0	\$2,700,000	2,700,000
504.000.4925	ADVANCES FROM ENTERPRISE FUNDS	\$0	\$0	\$0	\$0	\$0	\$0	-
TOTAL FUND 504		\$2,925,073	\$7,665,300	\$5,381,071	\$1,059,860	\$8,736,839	\$8,801,228	64,389 0.74%
WATER BOND SERVICE								
505.000.4701	INTEREST INCOME	\$1,950	\$2,816	\$429	\$81	\$1,700	\$750	(950) -55.88%
505.000.4891	REFUNDS	\$0	\$0	\$0	\$0	\$0	\$0	-
505.000.4901	GO BOND PROCEEDS	\$0	\$0	\$0	\$0	\$0	\$0	-
505.000.4902	REVENUE BOND PROCEEDS	\$0	\$0	\$0	\$12,875,101	\$0	\$0	-
505.000.4904	ACCRUED INTEREST	\$0	\$0	\$0	\$0	\$0	\$0	-
505.000.4905	PREMIUM OF BOND SALES	\$0	\$0	\$0	\$0	\$0	\$0	-
505.000.4911	OP TRANS FROM GENERAL FUND	\$0	\$0	\$0	\$0	\$0	\$0	-
505.000.4913	OP TRANS FROM DEBT SERVICE	\$0	\$0	\$0	\$0	\$0	\$0	-
505.000.4915	OP TRANS FROM ENTERPRISE FUNDS	\$1,751,074	\$1,750,598	\$1,782,953	\$1,753,481	\$1,315,000	\$1,225,000	(90,000) -6.84%
TOTAL FUND 505		\$1,753,024	\$1,753,414	\$1,783,382	\$14,628,662	\$1,316,700	\$1,225,750	(90,950) -6.91%
WATER BOND RESERVE								
506.000.4701	INTEREST INCOME	\$3,074	\$4,743	\$945	\$129	\$900	\$1,125	225 25.00%
506.000.4901	GO BOND PROCEEDS	\$0	\$0	\$0	\$0	\$0	\$0	-
TOTAL FUND 506		\$3,074	\$4,743	\$945	\$129	\$900	\$1,125	225 25.00%
SEWER FUND								
551.000.4441	WATER & SEWER ASSESSMENTS	\$34,228	\$33,310	\$33,376	\$36,815	\$35,000	\$35,000	- 0.00%
551.000.4521	SEWER CHARGES	\$3,933,379	\$4,083,975	\$4,074,076	\$4,092,671	\$3,985,000	\$4,119,079	134,079 3.36%
551.000.4522	TAP-IN FEES	\$99,650	\$100,350	\$109,750	\$124,113	\$115,000	\$90,000	(25,000) -21.74%
551.000.4523	CONTRIBUTIONS IN CAPITAL	\$0	\$0	\$0	\$0	\$0	\$0	-
551.000.4590	CONTRACT INSPECTION FEES	\$48,239	\$72,354	\$45,022	\$10,969	\$40,000	\$50,000	10,000 25.00%
551.000.4599	OTHER CHARGES FOR SERVICES	(\$6,841)	(\$14,444)	(\$13,029)	(\$10,252)	\$0	\$0	-
551.000.4701	INTEREST INCOME	\$123,405	\$161,808	\$176,238	\$79,318	\$75,000	\$118,977	43,977 58.64%
551.000.4890	AUCTION PROCEEDS	\$0	\$0	\$0	\$0	\$0	\$0	-
551.000.4891	REFUNDS	\$4,548	\$6,179	\$10,256	\$146	\$5,000	\$5,000	- 0.00%
551.000.4892	REIMBURSEMENTS/ I & I FUNDS FROM TCA	\$4,351	\$9,472	\$5,814	\$4,225	\$3,500	\$0	(3,500) -100.00%
551.000.4893	DONATIONS	\$0	\$0	\$0	\$0	\$0	\$0	-
551.000.4899	MISCELLANEOUS REVENUE	\$0	\$0	\$0	\$890	\$0	\$0	-
551.000.4909	SALE OF FIXED ASSETS - CAPITAL	\$0	\$0	\$0	\$0	\$0	\$0	-
551.000.4910	SALE OF FIXED ASSETS - NON-CAPITAL	\$0	\$0	\$0	\$0	\$0	\$0	-
551.000.4912	OP TRANS FROM SPECIAL REVENUE	\$0	\$0	\$0	\$0	\$0	\$0	-
551.000.4924	ADVANCES FROM CAPITAL PROJECTS	\$0	\$0	\$0	\$0	\$0	\$0	-
TOTAL FUND 551		\$4,240,960	\$4,453,004	\$4,441,502	\$4,338,896	\$4,258,500	\$4,418,056	159,556 3.75%

ESTIMATED REVENUE BUDGET WORKSHEET
CITY OF HUBER HEIGHTS

		2018	2019	2020	2021	2022	2023	\$	%
		Actual	Actual	Actual	Actual	Estimated	Estimated	incr / (decr)	incr / (decr)
		Revenue	Revenue	Revenue	Revenue	Revenue	Revenue	2023-2022	2023-2022
SEWER ACQ/CAPITAL									
552.000.4321	FEDERAL GRANTS	\$0	\$0	\$0	\$0	\$0	\$0	-	---
552.000.4701	INTEREST INCOME	\$7,098	\$17,203	\$5,771	\$5,144	\$5,000	\$7,717	2,717	54.34%
552.000.4892	REIMBURSEMENTS/ I & I FUNDS FROM TCA	\$0	\$0	\$0	\$0	\$0	\$0	-	---
552.000.4899	MISCELLANEOUS REVENUE	\$0	\$0	\$0	\$0	\$0	\$0	-	---
552.000.4903	NOTE PROCEEDS	\$0	\$0	\$0	\$0	\$0	\$0	-	---
552.000.4911	OP TRANS FROM GENERAL FUND	\$0	\$0	\$0	\$0	\$0	\$0	-	---
552.000.4915	OP TRANS FROM ENTERPRISE FUNDS	\$282,500	\$959,000	\$644,834	\$530,834	\$4,382,167	\$382,167	(4,000,000)	-91.28%
552.000.4921	ADVANCES FROM GENERAL FUND	\$0	\$0	\$0	\$0	\$0	\$0	-	---
552.000.4925	ADVANCES FROM ENTERPRISE FUNDS	\$0	\$0	\$0	\$0	\$0	\$0	-	---
TOTAL FUND 552		\$289,598	\$976,203	\$650,605	\$535,978	\$4,387,167	\$389,884	(3,997,283)	-91.11%
STORM WATER MANAGEMENT									
571.000.4323	COUNTY GRANTS	\$0	\$0	\$0	\$0	\$0	\$0	-	---
571.000.4442	COUNTY STORM WATER ASSESSMENTS	\$3,823	\$2,094	\$3,643	\$5,017	\$3,000	\$5,117	2,117	70.57%
571.000.4491	OTHER ASSESSMENTS	\$0	\$0	\$0	\$0	\$0	\$0	-	---
571.000.4530	STORMWATER CHARGES	\$593,006	\$600,610	\$599,201	\$612,491	\$615,000	\$1,076,250	461,250	75.00%
571.000.4590	CONTRACT INSPECTION FEES	\$51,298	\$48,124	\$48,729	\$10,716	\$35,000	\$35,000	-	0.00%
571.000.4701	INTEREST INCOME	\$0	\$0	\$0	\$0	\$0	\$0	-	---
571.000.4890	AUCTION PROCEEDS	\$0	\$0	\$0	\$0	\$0	\$0	-	---
571.000.4891	REFUNDS	\$2,815	\$3,198	\$5,955	\$90	\$2,500	\$2,500	-	0.00%
571.000.4892	REIMBURSEMENTS	\$4,530	\$4,552	\$2,476	\$251	\$2,000	\$2,000	-	0.00%
571.000.4906	LEASE PROCEEDS	\$0	\$0	\$0	\$0	\$0	\$0	-	---
571.000.4909	SALE OF CAPITAL ASSETS - CAPITAL	\$0	\$0	\$0	\$0	\$0	\$0	-	---
571.000.4910	SALE OF CAPITAL ASSETS - NON-CAPITAL	\$0	\$0	\$0	\$0	\$0	\$0	-	---
571.000.4911	OP TRANS FROM GENERAL FUND	\$0	\$0	\$0	\$0	\$0	\$0	-	---
571.000.4912	OP TRANS FROM SPECIAL REVENUE	\$0	\$0	\$0	\$0	\$0	\$0	-	---
571.000.4914	OP TRANS FROM CAPITAL PROJECTS	\$0	\$0	\$0	\$0	\$0	\$0	-	---
571.000.4921	ADVANCES FROM GENERAL FUND	\$0	\$0	\$0	\$0	\$0	\$0	-	---
571.000.4924	ADVANCES FROM CAPITAL PROJECTS	\$0	\$0	\$0	\$0	\$0	\$0	-	---
TOTAL FUND 571		\$655,472	\$658,578	\$660,005	\$628,564	\$657,500	\$1,120,867	463,367	70.47%
RECREATION ACTIVITY CENTER									
590.000.4830	COMMISSIONS	\$0	\$0	\$0	\$0	\$0	\$0	-	---
590.000.4840	MARKETING REVENUE	\$0	\$0	\$0	\$0	\$0	\$0	-	---
590.000.4893	DONATIONS	\$0	\$0	\$0	\$0	\$0	\$0	-	---
590.000.4899	MISCELLANEOUS REVENUE	\$0	\$0	\$0	\$0	\$0	\$0	-	---
590.000.4911	OP TRANS FROM GENERAL FUND	\$0	\$0	\$0	\$0	\$0	\$0	-	---
590.000.4921	ADVANCES FROM GENERAL FUND	\$0	\$0	\$0	\$0	\$0	\$0	-	---
TOTAL FUND 590		\$0	\$0	\$0	\$0	\$0	\$0	-	---
FIRE INSURANCE									
723.000.4896	ESCROW/DEPOSITS	\$0	\$44,000	\$0	\$16,080	\$0	\$0	-	---
TOTAL FUND 723		\$0	\$44,000	\$0	\$16,080	\$0	\$0	-	---
UNCLAIMED MONEY									
732.000.4898	UNCLAIMED MONEY	\$3,434	\$2,378	\$0	\$0	\$0	\$0	-	---
732.000.4917	OP TRANS FROM TRUSTS	\$0	\$0	\$0	\$0	\$0	\$0	-	---
TOTAL FUND 732		\$3,434.32	\$2,378.40	\$0.00	\$0.00	\$0.00	\$0.00	-	---
PRC-DC AGENCY									
801.000.4321	FEDERAL GRANTS	\$0	\$0	\$0	\$0	\$0	\$0	-	---
801.000.4899	MISCELLANEOUS REVENUE	\$0	\$0	\$0	\$0	\$0	\$0	-	---
801.000.4921	ADVANCES FROM GENERAL FUND	\$0	\$0	\$0	\$0	\$0	\$0	-	---
TOTAL FUND 801		\$0	\$0	\$0	\$0	\$0	\$0	-	---
CASH SURETY									
802.000.4896	ESCROW/DEPOSITS	\$299,000	\$306,500	\$130,500	\$267,776	\$225,000	\$300,000	75,000	33.33%

ESTIMATED REVENUE BUDGET WORKSHEET
CITY OF HUBER HEIGHTS

	2018 Actual Revenue	2019 Actual Revenue	2020 Actual Revenue	2021 Actual Revenue	2022 Estimated Revenue	2023 Estimated Revenue	\$ incr / (decr) 2023-2022	% incr / (decr) 2023-2022
TOTAL FUND 802	\$299,000	\$306,500	\$130,500	\$267,776	\$225,000	\$300,000	75,000	33.33%
TOTAL ALL FUNDS	\$73,788,296	\$86,783,471	\$101,661,713	\$124,391,422	\$98,711,416	\$105,807,506	7,096,090	7.19%

CITY OF HUBER HEIGHTS
YTD for Period Ending: October 31, 2022

	2018 ACTUAL	2019 ACTUAL	2020 ACTUAL	2021 ACTUAL	2022 ORIGINAL BUDGET	2022 REVISED BUDGET 10/31/2022	2022 EXPENDED 10/31/2022	2023 CITY MGR'S REQUEST	%Chg Revised
GENERAL FUND (101)	11,098,155	11,952,959	16,804,881	11,695,148	13,233,500	15,928,455	11,399,650	18,720,488	17.53
MOTOR VEHICLE (202)	246,138	247,780	253,997	272,403	286,419	286,419	234,818	324,339	13.24
GASOLINE TAX (203)	1,948,519	3,734,254	3,476,026	2,139,234	2,416,046	2,546,046	2,267,687	1,853,521	(27.20)
LIGHTING DISTRICT (207)	311,300	318,386	317,210	375,931	389,900	389,900	286,008	374,300	(4.00)
POLICE (209)	7,964,539	8,191,865	8,232,879	8,247,799	9,059,140	9,290,640	7,277,902	9,955,680	7.16
FIRE (210)	7,502,904	7,642,510	7,658,111	8,056,130	8,665,350	8,935,250	7,129,007	9,724,200	8.83
DRUG ENFORCEMENT (211)	0	9,232	0	2,001	4,608	4,608	0	5,349	16.08
LAW ENFORCEMENT (212)	44,399	10,147	19,686	56,257	53,921	53,921	29,267	30,505	(43.43)
STATE HIGHWAY MAINTENANCE (214)	30,971	329,806	1,195,228	208,336	120,750	120,750	33,154	279,950	131.84
COUNTY PERMISSIVE TAX (216)	85,100	79,000	70,000	72,000	0	0	0	0	--
CITY PERMISSIVE TAX (217)	192,000	195,000	199,145	130,000	91,000	91,000	91,000	406,000	346.15
PARKS & RECREATION (218)	1,710,925	1,417,261	1,765,446	3,226,135	2,068,429	2,263,429	1,635,425	4,970,464	119.60
NATUREWORKS (219)	0	0	0	0	0	0	0	0	--
COMMUNITY DEVELOPMENT BLOCK GRANT (222)	0	0	0	0	124,000	124,000	88,660	0	(100.00)
LOCAL STREET OPERATING (226)	2,393,302	2,140,456	1,916,077	2,085,631	2,901,536	3,016,536	2,315,142	2,732,386	(9.42)
BYRNE MEMORIAL GRANT (238)	0	0	0	0	36	36	0	36	0.00
MONTGOMERY COUNTY TIF (240)	1,982,562	1,491,079	1,920,802	2,651,803	2,196,875	2,196,875	2,192,626	5,070,950	130.83
FIREFIGHTERS ASSISTANCE GRANT (241)	0	0	0	0	0	0	0	0	--
LAW ENFORCEMENT ASSISTANCE GRANT (242)	20,273	6,383	0	1,106	164	24,490	24,490	135	(99.45)
MIAMI COUNTY TIF (243)	1,111,580	950,235	904,890	668,409	539,362	544,549	544,548	546,389	0.34
MIAMI COUNTY TIF DEC (244)	901,693	928,320	932,354	925,928	924,202	924,202	924,202	912,975	(1.21)
MIAMI COUNTY WEST TIF (245)	276,880	71,868	131,978	147,752	139,500	139,623	139,622	137,250	(1.70)
MONTGOMERY COUNTY CENTRAL TIF (246)	0	0	122	10,000	50,000	50,000	49,377	29,700	(40.60)
MONTGOMERY COUNTY SOUTH TIF (247)	119,728	496,371	147,036	40,047	119,000	119,000	117,247	155,000	30.25
MIAMI COUNTY NORTH FIREHOUSE TIF (248)	823	60,821	60,847	66,522	60,550	60,550	60,395	45,460	(24.92)
MONTGOMERY COUNTY LEXINGTON PLACE TIF (249)	0	0	0	162,410	204,000	494,000	493,329	224,000	(54.66)
ENTERPRISE ZONE (250)	0	0	0	0	0	0	0	0	--
FEMA (251)	41,289	17,245	44,911	75,043	0	0	0	56,500	--
ONEOHIO OPIOID SETTLEMENT (280)	0	0	0	0	0	0	0	15,000	--
CORONAVIRUS RELIEF (290)	0	0	2,234,007	0	0	0	0	0	--
AMERICAN RESCUE PLAN ACT (291)	0	0	0	120,000	3,876,672	3,876,672	0	3,892,628	0.41
SHUTTERED VENUE OPERATING GRANT (292)	0	0	0	5,770,054	0	0	0	0	--
SPECIAL ASSESSMENT BOND (305)	7,596,606	1,308,564	1,255,814	1,314,662	1,252,400	1,252,400	273,798	1,209,000	(3.47)
GENERAL OBLIGATION BOND (308)	4,662,855	2,488,615	2,477,227	9,849,994	2,866,000	2,866,000	594,385	2,854,000	(0.42)
CAPITAL IMPROVEMENTS (406)	11,018,370	2,930,329	3,103,141	9,737,286	1,526,460	4,230,913	1,312,086	4,999,700	18.17
TRANSFORMATIVE ECON. DEV. (410)	0	3,948,784	14,948,155	12,063,276	12,084,000	12,169,829	4,059,073	11,533,000	(5.23)
ISSUE 2 (421)	199,903	0	900,333	250,000	0	0	0	0	0.00

CITY OF HUBER HEIGHTS
YTD for Period Ending: October 31, 2022

	2018 ACTUAL	2019 ACTUAL	2020 ACTUAL	2021 ACTUAL	2022 ORIGINAL BUDGET	2022 REVISED BUDGET 10/31/2022	2022 EXPENDED 10/31/2022	2023 CITY MGR'S REQUEST	%Chg Revised
CAPITAL EQUIPMENT (424)	0	0	0	0	0	0	0	0	--
ED/GE CAPITAL IMPROVEMENT (427)	80,000	228,750	31,250	0	20,000	20,000	0	20,000	0.00
FIRE CAPITAL/EQUIPMENT (431)	865,769	431,006	958,941	1,127,918	2,039,100	2,111,290	1,766,255	3,546,200	67.96
LOCAL STREET CAPITAL IMPROVEMENT (433)	1,649,468	1,671,153	1,581,870	1,568,043	1,582,000	1,742,000	1,735,826	2,037,000	16.93
FEDERAL EQUITY SHARING PROGRAM (434)	27,007	9,913	18,094	71,251	52,908	52,908	22,917	66,538	25.76
LOCAL LAW ENFORCEMENT BLOCK GRANT (435)	0	0	0	0	0	0	0	0	--
FIREFIGHTERS ASSISTANCE GRANT (436)	255,002	216,846	0	205,543	15,386	15,386	15,356	0	(100.00)
ENERGY CONSERVATION GRANT (437)	0	0	0	0	1,809	1,809	0	1,809	0.00
PUBLIC ACCESS EASEMENT ACQUISITION (450)	0	0	0	0	0	0	0	0	--
CARRIAGE TRAILS INFRASTRUCTURE (454)	0	3,420,144	1,333,851	321,175	526,832	526,832	22,348	504,484	(4.24)
WATER FUND (501)	7,795,303	12,734,499	10,480,355	8,192,686	11,076,376	11,771,376	8,255,772	8,883,442	(24.53)
WATER CONSTRUCTION FUND (502)	0	0	0	0	0	0	0	0	--
WATER R & I FUND (503)	12,500	18,098	19,809	63,769	534,900	534,900	534,900	0	(100.00)
WATER UTILITY RESERVE (504)	3,483,051	12,507,621	139,984	1,308,941	7,642,167	7,687,167	5,579,925	6,508,600	(15.33)
WATER BOND SERVICE (505)	1,761,085	1,772,798	1,793,878	14,684,509	1,210,400	1,210,400	5,000	1,230,500	1.66
WATER BOND RESERVE (506)	0	0	0	0	0	0	0	0	--
SEWER FUND (551)	3,192,885	3,877,243	3,761,232	4,610,272	8,861,292	8,861,292	3,544,342	4,602,547	(48.06)
SEWER ACQUISITION (552)	386,366	911,125	688,631	594,068	4,382,167	4,382,167	4,326,841	382,167	(91.28)
STORM WATER MANAGEMENT (571)	759,272	749,211	554,015	560,010	718,991	718,991	438,824	1,326,010	84.43
RECREATION ACTIVITY CENTER (590)	0	0	0	0	0	0	0	0	--
FIRE INSURANCE (723)	0	0	44,000	16,080	3,151	40,694	40,693	0	(100.00)
UNCLAIMED MONIES (732)	1,833	655	0	0	18,383	18,383	831	33,335	81.34
PRC-DC AGENCY (801)	0	0	0	0	0	0	0	0	--
CASH SURETY (802)	232,500	344,000	131,556	140,400	225,000	225,000	164,022	300,000	33.33
TOTALS:	81,962,854	89,860,330	92,507,767	113,885,964	104,164,682	111,920,688	70,026,750	110,501,537	(1.27)

CITY OF HUBER HEIGHTS

STATE OF OHIO

ORDINANCE NO. 2022-O-

FOR MAKING APPROPRIATIONS FOR EXPENSES OF THE CITY OF HUBER HEIGHTS, OHIO FOR THE PERIOD BEGINNING JANUARY 1, 2023 AND ENDING DECEMBER 31, 2023.

NOW, THEREFORE, BE IT ORDAINED by the City Council of the City of Huber Heights, Ohio that:

To provide for the current expenses and other expenditures of the City of Huber Heights for the fiscal year ending December 31, 2023, the following sums be and are hereby appropriated from the monies in the Treasury of the City of Huber Heights and from the sum certified by the County Auditor to be received from taxation and from other sources.

Section 1. That there be appropriated from the 101 - General Fund:

a)	Dispatch:		
	Personnel	1,496,900	
	Operations and Capital	56,095	
	TOTAL		1,552,995
b)	Lighting:		
	Operations and Capital	43,000	
	TOTAL		43,000
c)	Economic Development:		
	Personnel	226,800	
	Operations and Capital	311,850	
	TOTAL		538,650
d)	Planning & Development:		
	Personnel	630,200	
	Operations and Capital	90,830	
	TOTAL		721,030
e)	Engineering:		
	Personnel	0	
	Operations and Capital	0	
	TOTAL		0
f)	Community Services:		
	Personnel	0	
	Operations and Capital	67,500	
	TOTAL		67,500
g)	Central Services:		
	Personnel	0	
	Operations and Capital	698,911	
	TOTAL		698,911

h)	Mayor:		
	Personnel	14,200	
	Operations and Capital	22,000	
	TOTAL		<u>36,200</u>
i)	Council:		
	Personnel	257,700	
	Operations and Capital	99,500	
	TOTAL		<u>357,200</u>
j)	Management:		
	Personnel	300,900	
	Operations and Capital	24,070	
	TOTAL		<u>324,970</u>
k)	Accounting:		
	Personnel	396,400	
	Operations and Capital	196,835	
	TOTAL		<u>593,235</u>
l)	Taxation:		
	Personnel	649,900	
	Operations and Capital	236,655	
	TOTAL		<u>886,555</u>
m)	Legal:		
	Operations and Capital	385,000	
	TOTAL		<u>385,000</u>
n)	Information Technology:		
	Personnel	201,700	
	Operations and Capital	294,719	
	TOTAL		<u>496,419</u>
o)	Human Resources:		
	Personnel	303,800	
	Operations and Capital	459,900	
	TOTAL		<u>763,700</u>
p)	Buildings and Grounds		
	Personnel	0	
	Operations and Capital	237,000	
	TOTAL		<u>237,000</u>
q)	Court:		
	Personnel	50,600	
	Operations and Capital	21,547	
	TOTAL		<u>72,147</u>
r)	Non-Departmental		
	Debt Service	201,500	
	Transfers	6,494,476	
	Advances	1,550,000	
	TOTAL		<u>8,245,976</u>
	GENERAL FUND TOTAL		<u><u>16,020,488</u></u>

Section 2. That there be appropriated from the 202 - Motor Vehicle Fund:

a)	Streets		
	Personnel	221,400	
	Operations and Capital	62,579	
	TOTAL		<u>283,979</u>
b)	Non-Departmental		
	Debt Service	0	
	Transfers	0	
	Advances	40,360	
	TOTAL		<u>40,360</u>
	MOTOR VEHICLE FUND TOTAL		<u><u>324,339</u></u>

Section 3. That there be appropriated from the 203 - Gasoline Tax Fund:

a)	Engineering		
	Operations and Capital	50,000	
	TOTAL		<u>50,000</u>
b)	Streets		
	Personnel	616,100	
	Operations and Capital	887,907	
	TOTAL		<u>1,504,007</u>
c)	Non-Departmental		
	Debt	0	
	Transfers	150,000	
	Advances	149,514	
	TOTAL		<u>299,514</u>
	GASOLINE TAX FUND TOTAL		<u><u>1,853,521</u></u>

Section 4. That there be appropriated from the 207 - Lighting District Fund:

	Personnel	26,300	
	Operations and Capital	348,000	
	LIGHTING DISTRICT FUND TOTAL		<u><u>374,300</u></u>

Section 5. That there be appropriated from the 209 -Police Fund:

a)	Police		
	Personnel	8,866,700	
	Operations and Capital	760,860	
	TOTAL		<u>9,627,560</u>
b)	Management		
	Personnel	24,200	
	Operations and Capital	0	
	TOTAL		<u>24,200</u>

c)	Non-Departmental	
	Debt Service	269,000
	Transfers	34,920
	Advances	0
	TOTAL	<u>303,920</u>
	POLICE FUND TOTAL	<u><u>9,955,680</u></u>

Section 6. That there be appropriated from the 210 - Fire Fund:

a)	Fire	
	Personnel	8,823,500
	Operations and Capital	868,740
	TOTAL	<u>9,692,240</u>
b)	Management	
	Personnel	24,200
	Operations and Capital	0
	TOTAL	<u>24,200</u>
c)	Non-Departmental	
	Debt Service	0
	Transfers	7,760
	Advances	0
	TOTAL	<u>7,760</u>
	FIRE FUND TOTAL	<u><u>9,724,200</u></u>

Section 7. That there be appropriated from the 211 - Drug Enforcement Fund:

	Operations and Capital	<u>5,349</u>
	DRUG ENFORCEMENT FUND TOTAL	<u><u>5,349</u></u>

Section 8. That there be appropriated from the 212 - Law Enforcement Fund:

	Operations and Capital	<u>30,505</u>
	LAW ENFORCEMENT FUND TOTAL	<u><u>30,505</u></u>

Section 9. That there be appropriated from the 214 - State Highway Maintenance Fund:

a)	Operations and Capital	<u>49,750</u>
	TOTAL	49,750
b)	Non-Departmental	
	Debt Service	75,500
	Transfers	154,700
	Advance	0
	TOTAL	<u>230,200</u>
	STATE HIGHWAY MNT FUND TOTAL	<u><u>279,950</u></u>

Section 10. That there be appropriated from the 216 - County Permissive Fund:

Transfers	0
Advances	0
COUNTY PERMISSIVE FUND TOTAL	0

Section 11. That there be appropriated from the 217 - City Permissive Fund:

Transfers	406,000
Advances	0
CITY PERMISSIVE FUND TOTAL	406,000

Section 12. That there be appropriated from the 218 - Parks & Recreation Fund:

a) Senior Center:	
Personnel	35,500
Operations and Capital	30,910
TOTAL	66,410
b) Park & Recreation:	
Personnel	300,900
Operations and Capital	2,181,259
TOTAL	2,482,159
c) Aquatic Center:	
Operations and Capital	497,045
TOTAL	497,045
d) Music Center:	
Personnel	34,000
Operations and Capital	490,850
TOTAL	524,850
e) Non-Departmental	
Debt Service	0
Transfers	0
Advances	1,400,000
TOTAL	1,400,000
PARKS & RECREATION FUND TOTAL	4,970,464

Section 13. That there be appropriated from the 222 - CDBG Fund:

a) Capital	
Operations and Capital	0
TOTAL	0
b) Non-Departmental	
Transfers	0
Advances	0
TOTAL	0
CDBG FUND TOTAL	0

Section 14. That there be appropriated from the 226 - Local Street Operating Fund:

a)	Streets		
	Personnel	1,623,400	
	Operations and Capital	<u>358,786</u>	
	TOTAL	1,982,186	
b)	Police		
	Personnel	<u>0</u>	
	TOTAL	0	
c)	Engineering:		
	Personnel	<u>153,600</u>	
	TOTAL	153,600	
d)	Management:		
	Personnel	<u>49,700</u>	
	TOTAL	49,700	
e)	Finance:		
	Personnel	58,100	
	Operations and Capital	<u>20,300</u>	
	TOTAL	78,400	
f)	Tax:		
	Personnel	<u>189,000</u>	
	TOTAL	189,000	
g)	Information Technology:		
	Personnel	<u>40,600</u>	
	TOTAL	40,600	
h)	Non-Departmental		
	Debt Service	136,000	
	Transfers	8,730	
	Advances	<u>94,170</u>	
	TOTAL	238,900	
	LOCAL STREET OPER. FUND TOTAL	<u><u>2,732,386</u></u>	

Section 15. That there be appropriated from the 238 - Byrne Memorial Grant Fund:

	Operations and Capital	<u>36</u>	
	BYRNE MEM. GRANT FUND TOTAL	<u><u>36</u></u>	

Section 16. That there be appropriated from the 240 – Montgomery County TIF Fund:

a) Finance:		
Operations and Capital		1,060,000
TOTAL		<u>1,060,000</u>
b) Non-Departmental		
Debt Service:		0
Transfers:		2,570,225
Advances:		<u>1,440,725</u>
TOTAL		<u>4,010,950</u>
MONTGOMERY CO. TIF FUND TOTAL		<u><u>5,070,950</u></u>

Section 17. That there be appropriated from the 242 - Law Enforcement Assistance Grant Fund:

Operations and Capital		135
Transfers		<u>0</u>
LAW ENF. ASST. GRANT FUND TOTAL		<u><u>135</u></u>

Section 18. That there be appropriated from the 243 – Miami County TIF Fund:

a) Finance:		
Operations and Capital		31,300
TOTAL		<u>31,300</u>
b) Non-Departmental		
Transfers:		515,089
Advances:		<u>0</u>
TOTAL		<u>515,089</u>
MIAMI CO. TIF FUND TOTAL		<u><u>546,389</u></u>

Section 19. That there be appropriated from the 244 – Miami County TIF (DEC) Fund:

a) Finance:		
Operations and Capital		0
TOTAL		<u>0</u>
b) Non-Departmental		
Transfers:		912,975
Advances:		<u>0</u>
TOTAL		<u>912,975</u>
MIAMI CO. TIF (DEC) FUND TOTAL		<u><u>912,975</u></u>

Section 20. That there be appropriated from the 245 – Miami County West TIF Fund:

a) Finance:		
Operations and Capital		2,300
TOTAL		<u>2,300</u>
b) Non-Departmental		
Transfers:		134,950
Advances:		<u>0</u>
TOTAL		<u>134,950</u>
MIAMI CO. WEST TIF FUND TOTAL		<u><u>137,250</u></u>

Section 21. That there be appropriated from the 246 – Montgomery County Central TIF Fund:

a) Finance:		
Operations and Capital		9,700
TOTAL		<u>9,700</u>
b) Non-Departmental		
Transfers:		20,000
Advances:		<u>0</u>
TOTAL		<u>20,000</u>
MONT CO. CENTRAL TIF FUND TOTAL		<u><u>29,700</u></u>

Section 22. That there be appropriated from the 247 – Montgomery County South TIF Fund:

a) Finance:		
Operations and Capital		35,000
TOTAL		<u>35,000</u>
b) Non-Departmental		
Transfers:		120,000
Advances:		<u>0</u>
TOTAL		<u>120,000</u>
MONT CO. SOUTH TIF FUND TOTAL		<u><u>155,000</u></u>

Section 23. That there be appropriated from the 248 – Miami County North Firehouse TIF Fund:

a) Finance:		
Operations and Capital		1,000
TOTAL		<u>1,000</u>
b) Non-Departmental		
Transfers:		44,460
Advances:		<u>0</u>
TOTAL		<u>44,460</u>
MIAMI CO. NORTH TIF FUND TOTAL		<u><u>45,460</u></u>

Section 24. That there be appropriated from the 249 – Montgomery County Lexington Place TIF Fund:

a)	Finance:		
	Operations and Capital		204,000
	TOTAL		<u>204,000</u>
b)	Non-Departmental		
	Transfers:		20,000
	Advances:		<u>0</u>
	TOTAL		<u>20,000</u>
	MONT CO. LEX. PL TIF FUND TOTAL		<u><u>224,000</u></u>

Section 25. That there be appropriated from the 251 – FEMA Fund:

a)	Finance:		
	Operations and Capital		0
	TOTAL		<u>0</u>
b)	Non-Departmental		
	Transfers:		56,500
	Advances:		<u>0</u>
	TOTAL		<u>56,500</u>
	FEMA FUND TOTAL		<u><u>56,500</u></u>

Section 26. That there be appropriated from the 280 – OneOhio Opioid Settlement Fund:

a)	Finance:		
	Operations and Capital		5,000
	TOTAL		<u>5,000</u>
b)	Non-Departmental		
	Transfers:		10,000
	Advances:		<u>0</u>
	TOTAL		<u>10,000</u>
	ONEOHIO OPIOID FUND TOTAL		<u><u>15,000</u></u>

Section 27. That there be appropriated from the 291 – American Rescue Plan Act Fund:

a)	Finance:		
	Operations and Capital		0
	TOTAL		<u>0</u>
b)	Non-Departmental		
	Transfers:		3,892,628
	Advances:		<u>0</u>
	TOTAL		<u>3,892,628</u>
	ARPA FUND TOTAL		<u><u>3,892,628</u></u>

Section 28. That there be appropriated from the 305 - Special Assessment Bond Retirement Fund:

a) Finance:		
Operations and Capital		70,000
TOTAL		<u>70,000</u>
b) Non-Departmental		
Debt Service		1,139,000
TOTAL		<u>1,139,000</u>
S.A. BOND RETIREMT FUND TOTAL		<u><u>1,209,000</u></u>

Section 29. That there be appropriated from the 308 - Bond Retirement Fund:

a) Finance:		
Operations and Capital		1,000
TOTAL		<u>1,000</u>
b) Non-Departmental		
Debt Service		2,853,000
TOTAL		<u>2,853,000</u>
G.O. BOND RETIREMT FUND TOTAL		<u><u>2,854,000</u></u>

Section 30. That there be appropriated from the 406 - Capital Improvement Fund:

a) Dispatch		
Personnel		130,800
TOTAL		<u>130,800</u>
b) Finance:		
Personnel		21,100
TOTAL		<u>21,100</u>
c) Capital		
Operations and Capital		4,329,500
TOTAL		<u>4,329,500</u>
d) Non-Departmental		
Debt Service		518,300
Transfers		0
Advances		0
TOTAL		<u>518,300</u>
CAPITAL IMPROVEMENT FUND TOTAL		<u><u>4,999,700</u></u>

Section 31. That there be appropriated from the 410 - Transformative Economic Development Fund:

a)	Economic Development:	
	Operations and Capital	291,000
	TOTAL	<u>291,000</u>
b)	Non-Departmental	
	Debt	11,242,000
	Transfers	<u>0</u>
	TOTAL	<u>11,242,000</u>
	T.E.D. FUND TOTAL	<u><u>11,533,000</u></u>

Section 32. That there be appropriated from the 421 - Issue 2 Fund:

a)	Capital	
	Operations and Capital	0
	TOTAL	<u>0</u>
b)	Non-Departmental	
	Transfers	0
	Advances	<u>0</u>
	TOTAL	<u>0</u>
	ISSUE 2 FUND TOTAL	<u><u>0</u></u>

Section 33. That there be appropriated from the 427 - ED/GE Capital Improvement Fund:

a)	Capital	
	Operations and Capital	0
	TOTAL	<u>0</u>
b)	Non-Departmental	
	Transfers	0
	Advances	<u>20,000</u>
	TOTAL	<u>20,000</u>
	ED/GE CAPITAL IMPR. FUND TOTAL	<u><u>20,000</u></u>

Section 34. That there be appropriated from the 431 - Fire Capital/Equipment Fund:

a)	Fire:	
	Operations and Capital	1,186,000
	TOTAL	<u>1,186,000</u>
b)	Finance:	
	Operations and Capital	3,700
	TOTAL	<u>3,700</u>
c)	Non-Departmental	
	Debt Service	2,356,500
	Transfers	<u>0</u>
	TOTAL	<u>2,356,500</u>
	FIRE CAPITAL/EQUIP. FUND TOTAL	<u><u>3,546,200</u></u>

Section 35. That there be appropriated from the 433 - Local Street Capital Fund:

a)	Street Capital:	
	Operations and Capital	2,020,000
	TOTAL	<u>2,020,000</u>
b)	Finance:	
	Operations and Capital	17,000
	TOTAL	<u>17,000</u>
c)	Non-Departmental	
	Advances	0
	TOTAL	<u>0</u>
	LOCAL STREET CAPITAL FUND TOTAL	<u><u>2,037,000</u></u>

Section 36. That there be appropriated from the 434 - Federal Equity Sharing Program Fund:

	Operations and Capital	<u>66,538</u>
	FEDERAL EQUITY FUND TOTAL	<u><u>66,538</u></u>

Section 37. That there be appropriated from the 436 - Firefighter's Assistance Grant Fund:

a)	Fire:	
	Operations and Capital	0
	TOTAL	<u>0</u>
b)	Non-Departmental	
	Transfers	0
	Advances	0
	TOTAL	<u>0</u>
	FF ASST. GRANT FUND TOTAL	<u><u>0</u></u>

Section 38. That there be appropriated from the 437 - Energy Conservation Grant Fund:

	Operations and Capital	<u>1,809</u>
	ENERGY CONS. GRANT FUND TOTAL	<u><u>1,809</u></u>

Section 39. That there be appropriated from the 454 - Carriage Trails Infrastructure Fund:

a)	Capital	
	Operations and Capital	0
	TOTAL	<u>0</u>
b)	Non-Departmental	
	Debt Service	0
	Advances	504,484
	TOTAL	<u>504,484</u>
	CARRIAGE TRAILS INFR. FUND TOTAL	<u><u>504,484</u></u>

Section 40. That there be appropriated from the 501 - Water Fund:

a)	Engineering:		
	Personnel		214,700
	Operations and Capital		4,009,861
	TOTAL		<u>4,224,561</u>
b)	Fire:		
	Personnel		34,000
	TOTAL		<u>34,000</u>
c)	Management:		
	Personnel		74,400
	TOTAL		<u>74,400</u>
d)	Finance:		
	Personnel		176,100
	Operations and Capital		27,471
	TOTAL		<u>203,571</u>
e)	Information Technology:		
	Personnel		80,900
	TOTAL		<u>80,900</u>
f)	Non-Departmental		
	Debt Service		1,305,500
	Transfers		2,433,600
	Advances		26,910
	TOTAL		<u>3,766,010</u>
	WATER FUND TOTAL		<u><u>8,383,442</u></u>

Section 41. That there be appropriated from the 503 - Renewal & Improvement Fund:

a)	Capital		
	Operations and Capital		0
	TOTAL		<u>0</u>
b)	Non-Departmental		
	Transfers		0
	TOTAL		<u>0</u>
	WATER R&I FUND TOTAL		<u><u>0</u></u>

Section 42. That there be appropriated from the 504 - Water Utility Reserve Fund:

a)	Capital		
	Operations and Capital		3,308,600
	TOTAL		<u>3,308,600</u>
b)	Non-Departmental		
	Debt Service		0
	Advances		0
	TOTAL		<u>0</u>
	WATER UTILITY RES. FUND TOTAL		<u><u>3,308,600</u></u>

Section 43. That there be appropriated from the 505 - Water Bond Service Fund:

a)	Capital	
	Operations and Capital	5,000
	TOTAL	<u>5,000</u>
b)	Non-Departmental	
	Debt Service	1,225,500
	Transfers	0
	TOTAL	<u>1,225,500</u>
	WATER BOND SERVICE FUND TOTAL	<u><u>1,230,500</u></u>

Section 44. That there be appropriated from the 551 - Sewer Fund:

a)	Engineering:	
	Personnel	214,700
	Operations and Capital	3,487,620
	TOTAL	<u>3,702,320</u>
b)	Management:	
	Personnel	74,400
	TOTAL	<u>74,400</u>
c)	Finance:	
	Personnel	176,100
	Operations and Capital	21,000
	TOTAL	<u>197,100</u>
d)	Information Technology:	
	Personnel	80,900
	TOTAL	<u>80,900</u>
e)	Non-Departmental	
	Debt Service	23,000
	Transfers	457,567
	Advances	67,260
	TOTAL	<u>547,827</u>
	SEWER FUND TOTAL	<u><u>4,602,547</u></u>

Section 45. That there be appropriated from the 552 - Sewer Acquisition/Capital Fund:

	Operations and Capital	382,167
	SEWER ACQ./CAPITAL FUND TOTAL	<u><u>382,167</u></u>

Section 46. That there be appropriated from the 571 - Storm Water Management Fund:

a)	Engineering:		
	Personnel	65,400	
	Operations and Capital	0	
	TOTAL		<u>65,400</u>
b)	Streets:		
	Personnel	312,600	
	Operations and Capital	468,150	
	TOTAL		<u>780,750</u>
c)	Management:		
	Personnel	36,900	
	TOTAL		<u>36,900</u>
d)	Finance:		
	Operations and Capital	0	
	TOTAL		<u>0</u>
e)	Capital:		
	Operations and Capital	378,600	
	TOTAL		<u>378,600</u>
f)	Non-Departmental:		
	Debt	24,000	
	Transfers	0	
	Advances	40,360	
	TOTAL		<u>64,360</u>
	STORM WATER FUND TOTAL		<u><u>1,326,010</u></u>

Section 47. That there be appropriated from the 723 - Fire Insurance Fund:

a)	Capital		
	Operations and Capital	0	
	TOTAL		<u>0</u>
b)	Non-Departmental		
	Transfers	0	
	Advances	0	
	TOTAL		<u>0</u>
	FIRE INSURANCE FUND TOTAL		<u><u>0</u></u>

Section 48. That there be appropriated from the 732 - Unclaimed Money Fund:

Operations and Capital	33,335
UNCLAIMED MONEY FUND TOTAL	<u>33,335</u>

Section 49. That there be appropriated from the 802 - Cash Surety Fund:

Operations and Capital	300,000
CASH SURETY FUND TOTAL	<u>300,000</u>

The Total of All Appropriations Shall Be: **104,101,537**

Section 50. The Director of Finance shall have authority to move money from one account number to another within any fund/department/expense classification (such as personnel, operations and capital, debt, transfers, or advances) without need of additional legislation.

Section 51. The Director of Finance is hereby authorized to draw checks on the City Treasury for payment from any of the foregoing appropriations upon receiving certificates and invoices therefore, approved by authorized officers of the City; provided that no checks shall be drawn or paid for salaries, wages, or other payments except as shall be authorized in accordance with law or ordinance.

Section 52. It is hereby found and determined that all formal actions of this Council concerning and relating to the passage of this Ordinance were adopted in an open meeting of this Council and that all deliberations of this Council and of any of its Committees that resulted in such formal action were in meetings open to the public and in compliance with all legal requirements including Section 121.22 of the Ohio Revised Code.

Section 53. This Ordinance shall go into effect upon its passage as provided by law and the Charter of the City of Huber Heights.

Passed by Council on the _____ day of _____, 2022;
_____Yeas; _____Nays.

Effective Date:

AUTHENTICATION:

Clerk of Council

Mayor

Date

Date

CITY OF HUBER HEIGHTS

STATE OF OHIO

ORDINANCE NO. 2022-O-

FOR MAKING APPROPRIATIONS FOR EXPENSES OF THE CITY OF HUBER HEIGHTS, OHIO FOR THE PERIOD BEGINNING JANUARY 1, 2023 AND ENDING DECEMBER 31, 2023.

NOW, THEREFORE, BE IT ORDAINED by the City Council of the City of Huber Heights, Ohio that:

To provide for the current expenses and other expenditures of the City of Huber Heights for the fiscal year ending December 31, 2023, the following sums be and are hereby appropriated from the monies in the Treasury of the City of Huber Heights and from the sum certified by the County Auditor to be received from taxation and from other sources.

Section 1. That there be appropriated from the 101 - General Fund:

a)	Dispatch:		
	Personnel	1,496,900	
	Operations and Capital	56,095	
	TOTAL		1,552,995
b)	Lighting:		
	Operations and Capital	43,000	
	TOTAL		43,000
c)	Economic Development:		
	Personnel	226,800	
	Operations and Capital	311,850	
	TOTAL		538,650
d)	Planning & Development:		
	Personnel	630,200	
	Operations and Capital	90,830	
	TOTAL		721,030
e)	Engineering:		
	Personnel	0	
	Operations and Capital	0	
	TOTAL		0
f)	Community Services:		
	Personnel	0	
	Operations and Capital	67,500	
	TOTAL		67,500
g)	Central Services:		
	Personnel	0	
	Operations and Capital	698,911	
	TOTAL		698,911

h)	Mayor:		
	Personnel	14,200	
	Operations and Capital	22,000	
	TOTAL		<u>36,200</u>
i)	Council:		
	Personnel	257,700	
	Operations and Capital	99,500	
	TOTAL		<u>357,200</u>
j)	Management:		
	Personnel	300,900	
	Operations and Capital	24,070	
	TOTAL		<u>324,970</u>
k)	Accounting:		
	Personnel	396,400	
	Operations and Capital	196,835	
	TOTAL		<u>593,235</u>
l)	Taxation:		
	Personnel	649,900	
	Operations and Capital	236,655	
	TOTAL		<u>886,555</u>
m)	Legal:		
	Operations and Capital	385,000	
	TOTAL		<u>385,000</u>
n)	Information Technology:		
	Personnel	201,700	
	Operations and Capital	294,719	
	TOTAL		<u>496,419</u>
o)	Human Resources:		
	Personnel	303,800	
	Operations and Capital	459,900	
	TOTAL		<u>763,700</u>
p)	Buildings and Grounds		
	Personnel	0	
	Operations and Capital	237,000	
	TOTAL		<u>237,000</u>
q)	Court:		
	Personnel	50,600	
	Operations and Capital	21,547	
	TOTAL		<u>72,147</u>
r)	Non-Departmental		
	Debt Service	201,500	
	Transfers	6,494,476	
	Advances	4,250,000	
	TOTAL		<u>10,945,976</u>
	GENERAL FUND TOTAL		<u><u>18,720,488</u></u>

Section 2. That there be appropriated from the 202 - Motor Vehicle Fund:

a)	Streets		
	Personnel	221,400	
	Operations and Capital	62,579	
	TOTAL		<u>283,979</u>
b)	Non-Departmental		
	Debt Service	0	
	Transfers	0	
	Advances	40,360	
	TOTAL		<u>40,360</u>
	MOTOR VEHICLE FUND TOTAL		<u><u>324,339</u></u>

Section 3. That there be appropriated from the 203 - Gasoline Tax Fund:

a)	Engineering		
	Operations and Capital	50,000	
	TOTAL		<u>50,000</u>
b)	Streets		
	Personnel	616,100	
	Operations and Capital	887,907	
	TOTAL		<u>1,504,007</u>
c)	Non-Departmental		
	Debt	0	
	Transfers	150,000	
	Advances	149,514	
	TOTAL		<u>299,514</u>
	GASOLINE TAX FUND TOTAL		<u><u>1,853,521</u></u>

Section 4. That there be appropriated from the 207 - Lighting District Fund:

	Personnel	26,300	
	Operations and Capital	348,000	
	LIGHTING DISTRICT FUND TOTAL		<u><u>374,300</u></u>

Section 5. That there be appropriated from the 209 -Police Fund:

a)	Police		
	Personnel	8,866,700	
	Operations and Capital	760,860	
	TOTAL		<u>9,627,560</u>
b)	Management		
	Personnel	24,200	
	Operations and Capital	0	
	TOTAL		<u>24,200</u>

c)	Non-Departmental	
	Debt Service	269,000
	Transfers	34,920
	Advances	0
	TOTAL	<u>303,920</u>
	POLICE FUND TOTAL	<u><u>9,955,680</u></u>

Section 6. That there be appropriated from the 210 - Fire Fund:

a)	Fire	
	Personnel	8,823,500
	Operations and Capital	868,740
	TOTAL	<u>9,692,240</u>
b)	Management	
	Personnel	24,200
	Operations and Capital	0
	TOTAL	<u>24,200</u>
c)	Non-Departmental	
	Debt Service	0
	Transfers	7,760
	Advances	0
	TOTAL	<u>7,760</u>
	FIRE FUND TOTAL	<u><u>9,724,200</u></u>

Section 7. That there be appropriated from the 211 - Drug Enforcement Fund:

	Operations and Capital	<u>5,349</u>
	DRUG ENFORCEMENT FUND TOTAL	<u><u>5,349</u></u>

Section 8. That there be appropriated from the 212 - Law Enforcement Fund:

	Operations and Capital	<u>30,505</u>
	LAW ENFORCEMENT FUND TOTAL	<u><u>30,505</u></u>

Section 9. That there be appropriated from the 214 - State Highway Maintenance Fund:

a)	Operations and Capital	<u>49,750</u>
	TOTAL	49,750
b)	Non-Departmental	
	Debt Service	75,500
	Transfers	154,700
	Advance	0
	TOTAL	<u>230,200</u>
	STATE HIGHWAY MNT FUND TOTAL	<u><u>279,950</u></u>

Section 10. That there be appropriated from the 216 - County Permissive Fund:

Transfers	0
Advances	0
COUNTY PERMISSIVE FUND TOTAL	0

Section 11. That there be appropriated from the 217 - City Permissive Fund:

Transfers	406,000
Advances	0
CITY PERMISSIVE FUND TOTAL	406,000

Section 12. That there be appropriated from the 218 - Parks & Recreation Fund:

a) Senior Center:	
Personnel	35,500
Operations and Capital	30,910
TOTAL	66,410
b) Park & Recreation:	
Personnel	300,900
Operations and Capital	2,181,259
TOTAL	2,482,159
c) Aquatic Center:	
Operations and Capital	497,045
TOTAL	497,045
d) Music Center:	
Personnel	34,000
Operations and Capital	490,850
TOTAL	524,850
e) Non-Departmental	
Debt Service	0
Transfers	0
Advances	1,400,000
TOTAL	1,400,000
PARKS & RECREATION FUND TOTAL	4,970,464

Section 13. That there be appropriated from the 222 - CDBG Fund:

a) Capital	
Operations and Capital	0
TOTAL	0
b) Non-Departmental	
Transfers	0
Advances	0
TOTAL	0
CDBG FUND TOTAL	0

Section 14. That there be appropriated from the 226 - Local Street Operating Fund:

a)	Streets		
	Personnel	1,623,400	
	Operations and Capital	<u>358,786</u>	
	TOTAL	1,982,186	
b)	Police		
	Personnel	<u>0</u>	
	TOTAL	0	
c)	Engineering:		
	Personnel	<u>153,600</u>	
	TOTAL	153,600	
d)	Management:		
	Personnel	<u>49,700</u>	
	TOTAL	49,700	
e)	Finance:		
	Personnel	58,100	
	Operations and Capital	<u>20,300</u>	
	TOTAL	78,400	
f)	Tax:		
	Personnel	<u>189,000</u>	
	TOTAL	189,000	
g)	Information Technology:		
	Personnel	<u>40,600</u>	
	TOTAL	40,600	
h)	Non-Departmental		
	Debt Service	136,000	
	Transfers	8,730	
	Advances	<u>94,170</u>	
	TOTAL	238,900	
	LOCAL STREET OPER. FUND TOTAL	<u><u>2,732,386</u></u>	

Section 15. That there be appropriated from the 238 - Byrne Memorial Grant Fund:

	Operations and Capital	<u>36</u>	
	BYRNE MEM. GRANT FUND TOTAL	<u><u>36</u></u>	

Section 16. That there be appropriated from the 240 - Montgomery County TIF Fund:

a)	Finance:		
	Operations and Capital	<u>1,060,000</u>	
	TOTAL	1,060,000	

b) Non-Departmental	
Debt Service:	0
Transfers:	2,570,225
Advances:	<u>1,440,725</u>
TOTAL	<u>4,010,950</u>

MONTGOMERY CO. TIF FUND TOTAL 5,070,950

Section 17. That there be appropriated from the 242 - Law Enforcement Assistance Grant Fund:

Operations and Capital	135
Transfers	<u>0</u>

LAW ENF. ASST. GRANT FUND TOTAL 135

Section 18. That there be appropriated from the 243 - Miami County TIF Fund:

a) Finance:	
Operations and Capital	<u>31,300</u>
TOTAL	31,300

b) Non-Departmental	
Transfers:	515,089
Advances:	<u>0</u>
TOTAL	<u>515,089</u>

MIAMI CO. TIF FUND TOTAL 546,389

Section 19. That there be appropriated from the 244 - Miami County TIF (DEC) Fund:

a) Finance:	
Operations and Capital	<u>0</u>
TOTAL	0

b) Non-Departmental	
Transfers:	912,975
Advances:	<u>0</u>
TOTAL	<u>912,975</u>

MIAMI CO. TIF (DEC) FUND TOTAL 912,975

Section 20. That there be appropriated from the 245 - Miami County West TIF Fund:

a) Finance:	
Operations and Capital	<u>2,300</u>
TOTAL	2,300

b) Non-Departmental	
Transfers:	134,950
Advances:	<u>0</u>
TOTAL	<u>134,950</u>

MIAMI CO. WEST TIF FUND TOTAL 137,250

Section 21. That there be appropriated from the 246 – Montgomery County Central TIF Fund:

a) Finance:		
Operations and Capital		9,700
TOTAL		<u>9,700</u>
b) Non-Departmental		
Transfers:		20,000
Advances:		<u>0</u>
TOTAL		<u>20,000</u>
MONT CO. CENTRAL TIF FUND TOTAL		<u><u>29,700</u></u>

Section 22. That there be appropriated from the 247 – Montgomery County South TIF Fund:

a) Finance:		
Operations and Capital		35,000
TOTAL		<u>35,000</u>
b) Non-Departmental		
Transfers:		120,000
Advances:		<u>0</u>
TOTAL		<u>120,000</u>
MONT CO. SOUTH TIF FUND TOTAL		<u><u>155,000</u></u>

Section 23. That there be appropriated from the 248 – Miami County North Firehouse TIF Fund:

a) Finance:		
Operations and Capital		1,000
TOTAL		<u>1,000</u>
b) Non-Departmental		
Transfers:		44,460
Advances:		<u>0</u>
TOTAL		<u>44,460</u>
MIAMI CO. NORTH TIF FUND TOTAL		<u><u>45,460</u></u>

Section 24. That there be appropriated from the 249 – Montgomery County Lexington Place TIF Fund:

a) Finance:		
Operations and Capital		204,000
TOTAL		<u>204,000</u>
b) Non-Departmental		
Transfers:		20,000
Advances:		<u>0</u>
TOTAL		<u>20,000</u>
MONT CO. LEX. PL TIF FUND TOTAL		<u><u>224,000</u></u>

Section 25. That there be appropriated from the 251 – FEMA Fund:

a)	Finance:		
	Operations and Capital		0
	TOTAL		0
b)	Non-Departmental		
	Transfers:	56,500	
	Advances:	0	
	TOTAL		56,500
	FEMA FUND TOTAL		56,500

Section 26. That there be appropriated from the 280 - OneOhio Opioid Settlement Fund:

a)	Finance:		
	Operations and Capital	5,000	
	TOTAL		5,000
b)	Non-Departmental		
	Transfers:	10,000	
	Advances:	0	
	TOTAL		10,000
	ONEOHIO OPIOID FUND TOTAL		15,000

Section 27. That there be appropriated from the 291 - American Rescue Plan Act Fund:

a)	Finance:		
	Operations and Capital	0	
	TOTAL		0
b)	Non-Departmental		
	Transfers:	3,892,628	
	Advances:	0	
	TOTAL		3,892,628
	ARPA FUND TOTAL		3,892,628

Section 28. That there be appropriated from the 305 - Special Assessment Bond Retirement Fund:

a)	Finance:		
	Operations and Capital	70,000	
	TOTAL		70,000
b)	Non-Departmental		
	Debt Service	1,139,000	
	TOTAL		1,139,000
	S.A. BOND RETIREMT FUND TOTAL		1,209,000

Section 29. That there be appropriated from the 308 - Bond Retirement Fund:

a)	Finance:		
	Operations and Capital		1,000
	TOTAL		<u>1,000</u>
b)	Non-Departmental		
	Debt Service		2,853,000
	TOTAL		<u>2,853,000</u>
	G.O. BOND RETIREMT FUND TOTAL		<u><u>2,854,000</u></u>

Section 30. That there be appropriated from the 406 - Capital Improvement Fund:

a)	Dispatch		
	Personnel		130,800
	TOTAL		<u>130,800</u>
b)	Finance:		
	Personnel		21,100
	TOTAL		<u>21,100</u>
c)	Capital		
	Operations and Capital		4,329,500
	TOTAL		<u>4,329,500</u>
d)	Non-Departmental		
	Debt Service		518,300
	Transfers		0
	Advances		0
	TOTAL		<u>518,300</u>
	CAPITAL IMPROVEMENT FUND TOTAL		<u><u>4,999,700</u></u>

Section 31. That there be appropriated from the 410 - Transformative Economic Development Fund:

a)	Economic Development:		
	Operations and Capital		291,000
	TOTAL		<u>291,000</u>
b)	Non-Departmental		
	Debt		11,242,000
	Transfers		0
	TOTAL		<u>11,242,000</u>
	T.E.D. FUND TOTAL		<u><u>11,533,000</u></u>

Section 32. That there be appropriated from the 421 - Issue 2 Fund:

a)	Capital	
	Operations and Capital	0
	TOTAL	0
b)	Non-Departmental	
	Transfers	0
	Advances	0
	TOTAL	0
	ISSUE 2 FUND TOTAL	0

Section 33. That there be appropriated from the 427 - ED/GE Capital Improvement Fund:

a)	Capital	
	Operations and Capital	0
	TOTAL	0
b)	Non-Departmental	
	Transfers	0
	Advances	20,000
	TOTAL	20,000
	ED/GE CAPITAL IMPR. FUND TOTAL	20,000

Section 34. That there be appropriated from the 431 - Fire Capital/Equipment Fund:

a)	Fire:	
	Operations and Capital	1,186,000
	TOTAL	1,186,000
b)	Finance:	
	Operations and Capital	3,700
	TOTAL	3,700
c)	Non-Departmental	
	Debt Service	2,356,500
	Transfers	0
	TOTAL	2,356,500
	FIRE CAPITAL/EQUIP. FUND TOTAL	3,546,200

Section 35. That there be appropriated from the 433 - Local Street Capital Fund:

a)	Street Capital:	
	Operations and Capital	2,020,000
	TOTAL	2,020,000
b)	Finance:	
	Operations and Capital	17,000
	TOTAL	17,000

c) Non-Departmental		
Advances		0
TOTAL		<u>0</u>
LOCAL STREET CAPITAL FUND TOTAL		<u><u>2,037,000</u></u>

Section 36. That there be appropriated from the 434 - Federal Equity Sharing Program Fund:

Operations and Capital		66,538
FEDERAL EQUITY FUND TOTAL		<u><u>66,538</u></u>

Section 37. That there be appropriated from the 436 - Firefighter's Assistance Grant Fund:

a) Fire:		
Operations and Capital		0
TOTAL		<u>0</u>
b) Non-Departmental		
Transfers		0
Advances		<u>0</u>
TOTAL		<u>0</u>
FF ASST. GRANT FUND TOTAL		<u><u>0</u></u>

Section 38. That there be appropriated from the 437 - Energy Conservation Grant Fund:

Operations and Capital		1,809
ENERGY CONS. GRANT FUND TOTAL		<u><u>1,809</u></u>

Section 39. That there be appropriated from the 454 - Carriage Trails Infrastructure Fund:

a) Capital		
Operations and Capital		0
TOTAL		<u>0</u>
b) Non-Departmental		
Debt Service		0
Advances		<u>504,484</u>
TOTAL		<u>504,484</u>
CARRIAGE TRAILS INFR. FUND TOTAL		<u><u>504,484</u></u>

Section 40. That there be appropriated from the 501 - Water Fund:

a) Engineering:		
Personnel		214,700
Operations and Capital		<u>4,009,861</u>
TOTAL		4,224,561

b)	Fire:		
	Personnel		34,000
	TOTAL		<u>34,000</u>
c)	Management:		
	Personnel		74,400
	TOTAL		<u>74,400</u>
d)	Finance:		
	Personnel	176,100	
	Operations and Capital	27,471	
	TOTAL		<u>203,571</u>
e)	Information Technology:		
	Personnel		80,900
	TOTAL		<u>80,900</u>
f)	Non-Departmental		
	Debt Service	1,305,500	
	Transfers	2,933,600	
	Advances	26,910	
	TOTAL		<u>4,266,010</u>
	WATER FUND TOTAL		<u><u>8,883,442</u></u>

Section 41. That there be appropriated from the 503 - Renewal & Improvement Fund:

a)	Capital		
	Operations and Capital		0
	TOTAL		<u>0</u>
b)	Non-Departmental		
	Transfers		0
	TOTAL		<u>0</u>
	WATER R&I FUND TOTAL		<u><u>0</u></u>

Section 42. That there be appropriated from the 504 - Water Utility Reserve Fund:

a)	Capital		
	Operations and Capital	6,508,600	
	TOTAL		<u>6,508,600</u>
b)	Non-Departmental		
	Debt Service	0	
	Advances	0	
	TOTAL		<u>0</u>
	WATER UTILITY RES. FUND TOTAL		<u><u>6,508,600</u></u>

Section 43. That there be appropriated from the 505 - Water Bond Service Fund:

a) Capital		
Operations and Capital		5,000
TOTAL		<u>5,000</u>
b) Non-Departmental		
Debt Service	1,225,500	
Transfers		<u>0</u>
TOTAL		<u>1,225,500</u>
WATER BOND SERVICE FUND TOTAL		<u><u>1,230,500</u></u>

Section 44. That there be appropriated from the 551 - Sewer Fund:

a) Engineering:		
Personnel	214,700	
Operations and Capital		<u>3,487,620</u>
TOTAL		<u>3,702,320</u>
b) Management:		
Personnel		<u>74,400</u>
TOTAL		<u>74,400</u>
c) Finance:		
Personnel	176,100	
Operations and Capital		<u>21,000</u>
TOTAL		<u>197,100</u>
d) Information Technology:		
Personnel		<u>80,900</u>
TOTAL		<u>80,900</u>
e) Non-Departmental		
Debt Service	23,000	
Transfers	457,567	
Advances		<u>67,260</u>
TOTAL		<u>547,827</u>
SEWER FUND TOTAL		<u><u>4,602,547</u></u>

Section 45. That there be appropriated from the 552 - Sewer Acquisition/Capital Fund:

Operations and Capital		<u>382,167</u>
SEWER ACQ./CAPITAL FUND TOTAL		<u><u>382,167</u></u>

Section 46. That there be appropriated from the 571 - Storm Water Management Fund:

a) Engineering:		
Personnel	65,400	
Operations and Capital		<u>0</u>
TOTAL		<u>65,400</u>

b)	Streets:		
	Personnel		312,600
	Operations and Capital		468,150
	TOTAL		<u>780,750</u>
c)	Management:		
	Personnel		36,900
	TOTAL		<u>36,900</u>
d)	Finance:		
	Operations and Capital		0
	TOTAL		<u>0</u>
e)	Capital:		
	Operations and Capital		378,600
	TOTAL		<u>378,600</u>
f)	Non-Departmental:		
	Debt		24,000
	Transfers		0
	Advances		40,360
	TOTAL		<u>64,360</u>
	STORM WATER FUND TOTAL		<u><u>1,326,010</u></u>

Section 47. That there be appropriated from the 723 - Fire Insurance Fund:

a)	Capital		
	Operations and Capital		0
	TOTAL		<u>0</u>
b)	Non-Departmental		
	Transfers		0
	Advances		0
	TOTAL		<u>0</u>
	FIRE INSURANCE FUND TOTAL		<u><u>0</u></u>

Section 48. That there be appropriated from the 732 - Unclaimed Money Fund:

	Operations and Capital		33,335
	UNCLAIMED MONEY FUND TOTAL		<u><u>33,335</u></u>

Section 49. That there be appropriated from the 802 - Cash Surety Fund:

	Operations and Capital		300,000
	CASH SURETY FUND TOTAL		<u><u>300,000</u></u>

The Total of All Appropriations Shall Be: **110,501,537**

Section 50. The Director of Finance shall have authority to move money from one account number to another within any fund/department/expense classification (such as personnel, operations and capital, debt, transfers, or advances) without need of additional legislation.

Section 51. The Director of Finance is hereby authorized to draw checks on the City Treasury for payment from any of the foregoing appropriations upon receiving certificates and invoices therefore, approved by authorized officers of the City; provided that no checks shall be drawn or paid for salaries, wages, or other payments except as shall be authorized in accordance with law or ordinance.

Section 52. It is hereby found and determined that all formal actions of this Council concerning and relating to the passage of this Ordinance were adopted in an open meeting of this Council and that all deliberations of this Council and of any of its Committees that resulted in such formal action were in meetings open to the public and in compliance with all legal requirements including Section 121.22 of the Ohio Revised Code.

Section 53. This Ordinance shall go into effect upon its passage as provided by law and the Charter of the City of Huber Heights.

Passed by Council on the _____ day of _____, 2022;
_____Yeas; _____Nays.

Effective Date:

AUTHENTICATION:

Clerk of Council

Mayor

Date

Date

AI-8858

**New Business A.
City Council**

City Council Special Meeting

Meeting Date: 12/15/2022

Board of Zoning Appeals Reappointment - S. Davidson

Submitted By: Anthony Rodgers

Department: City Council

Council Committee Review?: Council Work Session

Date(s) of Committee Review: 12/06/2022

Audio-Visual Needs: None **Emergency Legislation?:** No

**Motion/Ordinance/
Resolution No.:**

Agenda Item Description or Legislation Title

A Motion To Reappoint Scott Davidson To The Board Of Zoning Appeals For A Term Ending January 31, 2028.

Purpose and Background

City Staff recommend the reappointment of Scott Davidson to the Board of Zoning Appeals for a term ending January 31, 2028. The current term expires on January 31, 2023.

An updated background check was not needed for Mr. Davidson due to the recent nature of his initial appointment.

Fiscal Impact

Source of Funds: N/A

Cost: N/A

Recurring Cost? (Yes/No): N/A

Funds Available in Current Budget? (Yes/No): N/A

Financial Implications:

Attachments

No file(s) attached.

AI-8857

**New Business B.
City Council**

City Council Special Meeting

Meeting Date: 12/15/2022

2023 MVRPC Appointments

Submitted By: Anthony Rodgers

Department: City Council

Council Committee Review?: Council Work Session

Date(s) of Committee Review: 12/06/2022

Audio-Visual Needs: None **Emergency Legislation?:** No

**Motion/Ordinance/
Resolution No.:**

Agenda Item Description or Legislation Title

A Motion To Designate Nancy Byrge As The City Representative And Don Webb As The Alternate City Representative To The Miami Valley Regional Planning Commission (MVRPC) And To Designate Russ Bergman As The City Representative And Bryan Chodkowski As The Alternate City Representative To The Miami Valley Regional Planning Commission (MVRPC) Technical Advisory Committee For 2023.

Purpose and Background

Each year, City Council must make appointments for City representatives to the Miami Valley Regional Planning Commission (MVRPC). City Council appoints one representative and one alternate representative from members of Council to the MVRPC. City Council also appoints City Engineer Russ Bergman as a representative and another City Staff as an alternate representative to the MVRPC TEC Advisory Committee.

Fiscal Impact

Source of Funds: N/A

Cost: N/A

Recurring Cost? (Yes/No): N/A

Funds Available in Current Budget? (Yes/No): N/A

Financial Implications:

Attachments

No file(s) attached.

AI-8868

New Business C.
City Council

City Council Special Meeting

Meeting Date: 12/15/2022

2023 First Suburbs Consortium Appointments

Submitted By: Anthony Rodgers

Department: City Council

Council Committee Review?: Council Work Session

Date(s) of Committee Review: 12/06/2022

Audio-Visual Needs: None **Emergency Legislation?:** No

**Motion/Ordinance/
Resolution No.:**

Agenda Item Description or Legislation Title

A Motion To Designate Anita Kitchen And Richard Shaw As City Representatives And Glenn Otto As The Alternate City Representative To The First Suburbs Consortium For 2023.

Purpose and Background

Each year, City Council must make appointments for City representatives to the First Suburbs Consortium. City Council appoints two representatives and one alternate representative from the members of Council to the First Suburbs Consortium.

Fiscal Impact

Source of Funds: N/A

Cost: N/A

Recurring Cost? (Yes/No): N/A

Funds Available in Current Budget? (Yes/No): N/A

Financial Implications:

Attachments

No file(s) attached.

AI-8856

**New Business D.
City Council**

City Council Special Meeting

Meeting Date: 12/15/2022

2023 Law Director Contract

Submitted By: Anthony Rodgers

Department: City Council

Council Committee Review?: Council Work Session
Date(s) of Committee Review: 12/06/2022

Audio-Visual Needs: None
Emergency Legislation?: No

**Motion/Ordinance/
Resolution No.:**

Agenda Item Description or Legislation Title

A Resolution Authorizing The City Of Huber Heights To Renew An Agreement With Pickrel, Schaeffer And Ebeling For Legal Services As Law Director For The City Of Huber Heights, Ohio For The Time Period Of January 1, 2023 Through December 31, 2023.
(first reading)

Purpose and Background

This agenda item is the contract renewal for the City Law Director, with David Montgomery replacing Gerald McDonald. The current contract terminates on December 31, 2022. The 2023 proposed contract retains the rates and terms of the current 2022 contract for prosecutor services and the 2023 proposed contract retains the same terms and rates for other legal services.

Fiscal Impact

Source of Funds: N/A

Cost: N/A

Recurring Cost? (Yes/No): N/A

Funds Available in Current Budget? (Yes/No): N/A

Financial Implications:

Attachments

Resolution

Exhibit A

CITY OF HUBER HEIGHTS
STATE OF OHIO

RESOLUTION NO. 2022-R-

AUTHORIZING THE CITY OF HUBER HEIGHTS TO RENEW AN AGREEMENT WITH PICKREL, SCHAEFFER AND EBELING FOR LEGAL SERVICES AS LAW DIRECTOR FOR THE CITY OF HUBER HEIGHTS, OHIO FOR THE TIME PERIOD OF JANUARY 1, 2023 THROUGH DECEMBER 31, 2023.

WHEREAS, the law firm of Pickrel, Schaeffer and Ebeling has been serving as law director for the City of Huber Heights since October 31, 2003; and

WHEREAS, Council desires to renew the relationship for an additional year.

NOW, THEREFORE, BE IT RESOLVED by the City Council of Huber Heights, Ohio that:

Section 1. By an affirmative vote of City Council, the Mayor is directed to execute on behalf of the City of Huber Heights a contract substantially upon the same provisions contained in the attached as set forth in Exhibit A appointing Pickrel, Schaeffer and Ebeling as legal counsel for the City and designating David Montgomery as Law Director for the period of January 1, 2023 through December 31, 2023.

Section 2. It is hereby found and determined that all formal actions of this Council concerning and relating to the passage of this Resolution were adopted in an open meeting of this Council and that all deliberations of this Council and of any of its Committees that resulted in such formal action were in meetings open to the public and in compliance with all legal requirements including Section 121.22 of the Ohio Revised Code.

Section 3. This Resolution shall go into effect upon its passage as provided by law and the Charter of the City of Huber Heights.

Passed by Council on the _____ day of _____, 2022;
_____ Yeas; _____ Nays.

Effective Date:

AUTHENTICATION:

Clerk of Council

Mayor

Date

Date

EXHIBIT A
LAW DIRECTOR CONTRACT

This Contract is entered into this ____ day of December, 2022, by and between the City of Huber Heights, OHIO, an Ohio municipal corporation ("HUBER HEIGHTS"), 6131 Taylorsville Road, Huber Heights, Ohio 45424, and PICKREL, SCHAEFFER & EBELING CO., L.P.A. ("PSE"), 2700 Stratacache Tower, Dayton, Ohio 45423.

WHEREAS, the law firm of Pickrel, Schaeffer and Ebeling ("PSE") has been serving as the Law Director for the City of Huber Heights since October 31, 2003; and

WHEREAS, the Law Director shall serve as the chief legal advisor to Council, the City Manager, and all City departments, divisions, offices and other agencies, boards or commissions; and

WHEREAS, the City Council wishes to renew the contract with the law firm of PSE as the Law Director to represent the City in all legal proceedings and to perform any other duties prescribed in the City Charter;

NOW THEREFORE, for valuable consideration, receipt of which is hereby acknowledged, and for the mutual covenants herein below set forth, the parties agree as follows:

1. PSE shall provide all legal services at the rates set forth in Addendum A.
2. PSE shall designate DAVID MONTGOMERY as the City Attorney/Law Director for the City of Huber Heights, Ohio and DAVID MONTGOMERY shall act in that capacity for and on behalf of HUBER HEIGHTS.
3. It is understood by the parties hereto that legal services provided by PSE, may be accomplished through an individual attorney or attorneys or paralegals and staff other than the designated City Attorney/Law Director. The decision to use attorneys or other staff at PSE to provide legal services shall be made by the City Attorney/Law Director. It is understood that in making this decision the attorney or other staff providing such legal services to HUBER HEIGHTS will be under the supervision of the City Attorney/Law Director, and the City Attorney/Law Director shall advise the City Council and the City Manager of the fact that another attorney has been assigned the particular project. It is anticipated that the City shall have direct access to other attorney and staff at PSE, as agreed to by the City and Law Director.
4. No legal services shall be performed by PSE for HUBER HEIGHTS except as authorized by the City Charter and City Council, or as requested by the City Manager and Senior City Administrators. The City Council shall be responsible for the administration and management of the Law Director. The primary contact shall be through the City Council. The City Council shall be consulted on all administrative matters involving the Law Director. Conflicts of interest shall be resolved between PSE and Council.
5. The term of this Contract shall commence on January 1, 2023 and shall run through December 31, 2023. This Contract may be renewed by the mutual agreement of HUBER

HEIGHTS and PSE for additional one-year periods, commencing January 1, through December 31, of each subsequent year. The term of this Contract and the renewal of this Contract are subject to the rights of terminations set forth in paragraph 6. The billing rates set forth in the PSE Response may be renegotiated at the time of each renewal.

6. This Contract may be terminated by HUBER HEIGHTS at any time for any reason by giving thirty (30) days prior written notice to PSE of its intent to terminate. In terminating this Contract, the City may require that PSE continue to provide legal services for a period greater than thirty (30) days as determined in the sole discretion of HUBER HEIGHTS for the billing rate set forth in Addendum A. Notwithstanding the right of termination by HUBER HEIGHTS as herein set forth, PSE upon receipt of notice of termination shall continue to provide appropriate legal services to HUBER HEIGHTS as required by those ethical standards applicable to practicing lawyers in the State of Ohio. PSE shall have the same right of termination, as HUBER HEIGHTS except PSE shall give HUBER HEIGHTS sixty (60) day prior written notice of its intent to terminate.

7. In addition to the duties as Law Director, PSE shall provide legal representation to City by representing the City in all prosecutions under City ordinances and State statutes in Miami County Municipal Court. PSE shall provide such service and devote such time as is necessary in order to represent the City effectively on: all Huber Heights ordinance violations filed in Miami County Municipal Court, District Court; preliminary hearings/prosecution of Ohio Revised Code ordinances occurring in the City that are heard in Miami County Municipal Court; and driver license suspension hearings for Huber Heights citizen heard in Miami County Municipal Court. PSE shall also provide, upon request, reasonable reports from time to time as to the number and type of cases handled, attorneys involved, number of cases tried as opposed to those disposed of by agreement, etc., as may be reasonably requested by the City. The cost for such criminal prosecution services shall not exceed \$4,500 annually. This not to exceed amount does not include costs for preparing legal briefs and preparation for appellate arguments on cases that may be appealed to the Court of Appeals or to the Supreme Court. Katrina Wahl and Matthew Sorg shall retain the designation as "City Prosecutors" on behalf of the Law Firm and shall be the primary contacts with the City's Police Division. The Law Firm may have other attorneys provide services from time to time. PSE shall give HUBER HEIGHTS thirty (30) day prior written notice of its intent to designate a new City Attorney/Law Director or City Prosecutor.

8. All notices, requests, demands and other communications hereunder shall be in writing and shall be deemed to have been given when delivered personally or when deposited in the United States mail, certified and with proper postage prepaid and return receipt requested, addressed as follows:

AS TO PSE:
Gerald McDonald
Pickrel Schaeffer & Ebeling
2700 Stratacache Tower
Dayton, Ohio 45423

AS TO HUBER HEIGHTS:
Mayor Jeff Gore
City Council
City of Huber Heights
6131 Taylorsville Road
Huber Heights, Ohio 45424

IN WITNESS WHEREOF, the parties set their hands hereto on the day and date first written above.

WITNESSES:

City of Huber Heights, Ohio

Name

Jeff Gore, Mayor

Printed Name

Pickrel, Schaeffer & Ebeling, LPA

Name

Michael Sandner, President

Printed Name

Addendum A
To Law Director Contract 2023

All services rendered by PSE lawyers shall be at the rate of \$175.00 per hour.
Paralegal Fees shall be at the rate of \$95.00 per hour.

AI-8831

New Business E.
City Manager

City Council Special Meeting

Meeting Date: 12/15/2022

Increase Not To Exceed Amount - Joint Venture

Submitted By: Jim Bell

Department: Finance

Division: Accounting

Council Committee Review?: Council
Work
Session

Date(s) of Committee Review: 12/06/2022

Audio-Visual Needs: None

Emergency Legislation?: No

**Motion/Ordinance/
Resolution No.:**

Agenda Item Description or Legislation Title

A Resolution To Increase The Not To Exceed Amount For Joint Venture For Marketing Services For The Kroger Aquatic Center In Calendar Year 2022.
(first reading)

Purpose and Background

City Staff requested additional marketing services be provided by Joint Venture for the Kroger Aquatic Center in 2022. These additional services exceeded the vendor limit of \$25,000 per year by \$3,017. City Staff request that City Council approve the additional spending with this vendor to a total amount of \$28,017 for services provided in 2022.

Fiscal Impact

Source of Funds: Parks & Recreation Fund

Cost: \$3,017

Recurring Cost? (Yes/No): No

Funds Available in Current Budget? (Yes/No): Yes

Financial Implications:

Attachments

Resolution

CITY OF HUBER HEIGHTS
STATE OF OHIO

RESOLUTION NO. 2022-R-

TO INCREASE THE NOT TO EXCEED AMOUNT FOR JOINT VENTURE FOR MARKETING SERVICES FOR THE KROGER AQUATIC CENTER IN CALENDAR YEAR 2022.

WHEREAS, Joint Venture has previously provided marketing services for the Kroger Aquatic Center for the City of Huber Heights; and

WHEREAS, Joint Venture provided additional marketing services for the Kroger Aquatic Center in 2022; and

WHEREAS, the City Charter requires that City Council approve all work performed by a single vendor in excess of \$25,000.00 in any given year.

NOW, THEREFORE, BE IT RESOLVED by the City Council of Huber Heights, Ohio that:

Section 1. The Interim City Manager is hereby authorized to increase the not to exceed amount for Joint Venture to a new total of \$28,017.00 to cover all additional expenses throughout Calendar Year 2022 as needed.

Section 2. It is hereby found and determined that all formal actions of this Council concerning and relating to the passage of this Resolution were adopted in an open meeting of this Council and that all deliberations of this Council and of any of its Committees that resulted in such formal action were in meetings open to the public and in compliance with all legal requirements including Section 121.22 of the Ohio Revised Code.

Section 3. This Resolution shall go into effect upon its passage as provided by law and the Charter of the City of Huber Heights.

Passed by Council on the _____ day of _____, 2022;
_____ Yeas; _____ Nays.

Effective Date:

AUTHENTICATION:

Clerk of Council

Mayor

Date

Date

AI-8854

**New Business F.
City Manager**

City Council Special Meeting

Meeting Date: 12/15/2022

City Renewal Levy - Ballot Measure - Ordinance

Submitted By: Bryan Chodkowski

Department: City Manager

Council Committee Review?: Council Work Session
Date(s) of Committee Review: 12/06/2022

Audio-Visual Needs: None
Emergency Legislation?:

**Motion/Ordinance/
Resolution No.:**

Agenda Item Description or Legislation Title

An Ordinance Providing For The Continuation Of An Existing .25 Percent Levy On Income Effective January 1, 2025 And Expiring December 31, 2034, And To Submit This Ordinance To The Electorate For Approval Or Rejection And Contingent Upon Such Election Approval, Amend Section 192.012(B) Of Chapter 192, Income Tax, Of Title 9, Taxation Part I, Administration To Reflect The Tax Continuation. (first reading)

Purpose and Background

Pursuant to the wishes of Council, this legislation will authorize the placement of a renewal of the 0.25% income tax for public safety service, which expires on December 31, 2024, before the electorate at the May 2, 2023 primary election. This ordinance authorizes the continuation of the current levy, 0.25% for a period of 10 years, at the same rate of 0.25% for an additional 10-year period.

To meet Board of Election timelines, it is recommended that Council waive the period between first and second readings, and adopt this non-emergency legislation on December 12, 2022. Adoption under these conditions will still provide for the 30-day referendum period.

Fiscal Impact

Source of Funds: N/A

Cost: N/A

Recurring Cost? (Yes/No): N/A

Funds Available in Current Budget? (Yes/No): N/A

Financial Implications:

Attachments

Ordinance

CITY OF HUBER HEIGHTS
STATE OF OHIO

ORDINANCE NO. 2022-O-

PROVIDING FOR THE CONTINUATION OF AN EXISTING .25 PERCENT LEVY ON INCOME EFFECTIVE JANUARY 1, 2025 AND EXPIRING DECEMBER 31, 2034, AND TO SUBMIT THIS ORDINANCE TO THE ELECTORATE FOR APPROVAL OR REJECTION AND CONTINGENT UPON SUCH ELECTION APPROVAL, AMEND SECTION 192.012(B) OF CHAPTER 192, INCOME TAX, OF TITLE 9, TAXATION PART I, ADMINISTRATION TO REFLECT THE TAX CONTINUATION.

WHEREAS, at the general election on November 4, 2014, a majority of the electors of the City of Huber Heights voted to approve a .25% levy on income, effective January 1, 2015, for a 10-year period expiring December 31, 2024, in order to provide for police and fire public safety and support, which did not tax social security benefits, pensions, interest payments, inheritance and other items excluded by the city income tax ordinance; and

WHEREAS, after deliberation the Council of the City of Huber Heights seeks to continue the existing .25% income tax rate of income tax beyond December 31, 2024, for an additional ten years; and

WHEREAS, pursuant to section 10.04 of the Charter of the City of Huber Heights, Ohio, and the Ohio Revised Code, City Council must submit this issue to the electorate of the City for approval or rejection.

NOW, THEREFORE, BE IT ORDAINED by the City Council of Huber Heights, Ohio that:

Section 1. Subject to approval of the electors of the City of Huber Heights Ohio, a continuation of an existing .25% levy on income to provide for police and fire public safety and support, which shall not tax social security benefits, pensions, interest payments, inheritance and other items excluded by the City income tax ordinance effective January 1, 2025 and expiring December 31, 2034 is adopted

Section 2. The proposed continuation in the rate of income tax shall be submitted by ballot to the electorate of the City for approval or rejection, on May 2, 2023, the date of the primary election.

Section 3. If a majority of the electors voting thereon approve the proposed continuation in the rate of income tax, the income tax levy shall be so continued effective January 1, 2025, through December 31, 2034.

Section 4. Contingent upon such election approval, Section 192.012(B) of Chapter 192 Income Tax, of Title 9, Taxation Part 1, Administration of the Ordinances of the City of Huber Heights, Ohio shall be amended by adding the following language at the end of Section 192.012 (B):

“Beginning January 1, 2025, the income tax of .25% shall remain in effect for ten years to provide for police and fire public safety and support, as approved by the voters on May 2, 2023.

Section 5. The levy of the annual income tax continuation is made in accordance with Chapter 718 of the Ohio Revised Code, the same being incorporated herein, and pursuant to said Chapter 718, the annual tax continuation authorized herein shall be levied on the income of every person residing in or earning or receiving income in the City of Huber Heights and shall be measured by municipal taxable income and shall be subject to the credit for taxes paid to other municipalities as is provided in Section 192.081 of the Huber Heights Codified Ordinances.

Section 6. The Clerk of Council is directed to certify a copy of this Ordinance to the Board of Elections of Montgomery County and Miami County and to take all steps necessary to place this issue on the ballot.

Section 7. It is hereby found and determined that all formal actions of this Council concerning and relating to the passage of this Ordinance were adopted in an open meeting of this Council and that all deliberations of this Council and of any of its Committees that resulted in such formal action were taken in meetings open to the public and in conformance with all legal requirements including Section 121.22 of the Ohio Revised Code.

Section 8. This Ordinance shall go into effect upon its passage as provided by law and the Charter of the City of Huber Heights.

Passed by Council on the ____ day of _____, 2022;
______ Yeas; _____ Nays.

Effective Date:

AUTHENTICATION:

Clerk of Council

Mayor

Date

Date

AI-8855

New Business G.
City Manager

City Council Special Meeting

Meeting Date: 12/15/2022

City Renewal Levy - Ballot Measure - Resolution

Submitted By: Bryan Chodkowski

Department: City Manager

Council Committee Review?: Council Work Session
Date(s) of Committee Review: 12/06/2022

Audio-Visual Needs: None
Emergency Legislation?: No

**Motion/Ordinance/
Resolution No.:**

Agenda Item Description or Legislation Title

A Resolution Specifying May 2, 2023 As The Date For Submitting To The Electorate Of The City Of Huber Heights A Proposal To Provide For The Continuation Of An Existing .25% Levy On Income Effective January 1, 2025 And Expiring December 31, 2034 And Directing The Board Of Elections Of Montgomery County And Miami County, Ohio To Place The Issue On The Ballot.
(first reading)

Purpose and Background

This legislation directs the Boards of Elections to place the renewal of the 0.25% income tax to fund public safety services expiring December 31, 2024 on the May 2, 2023 primary ballot for consideration by the electorate.

Fiscal Impact

Source of Funds: N/A

Cost: N/A

Recurring Cost? (Yes/No): N/A

Funds Available in Current Budget? (Yes/No): N/A

Financial Implications:

Attachments

Resolution

CITY OF HUBER HEIGHTS
STATE OF OHIO

RESOLUTION NO. 2022-R-

SPECIFYING MAY 2, 2023 AS THE DATE FOR SUBMITTING TO THE ELECTORATE OF THE CITY OF HUBER HEIGHTS A PROPOSAL TO PROVIDE FOR THE CONTINUATION OF AN EXISTING .25% LEVY ON INCOME EFFECTIVE JANUARY 1, 2025, AND EXPIRING DECEMBER 31, 2034 AND DIRECTING THE BOARD OF ELECTIONS OF MONTGOMERY COUNTY AND MIAMI COUNTY, OHIO TO PLACE THE ISSUE ON THE BALLOT.

WHEREAS, Ordinance No. 2022-O _____, passed concurrently with the adoption of this Resolution provides for submitting to the electorate of the City of Huber Heights a proposal to continue the existing .25% levy on income, effective January 1, 2025; and

WHEREAS, Huber Heights Charter and Section 718.04 of the Ohio Revised Code requires that any income tax in excess of 1% shall not be levied without first having been approved by a majority of the electors voting on the issue.

NOW, THEREFORE, BE IT RESOLVED by the City Council of Huber Heights, Ohio that:

Section 1. May 2, 2023 is specified as the date of the election to be held to submit to the electors of the City of Huber Heights for their approval Ordinance No. 2022-O-_____ which provides for the continuation of an existing .25% levy on income, effective January 1, 2025 for a 10-year period expiring December 31, 2034 in order to provide for police and fire public safety and support, which will not tax social security benefits, pensions, interest payments, inheritance and other items excluded by the city income tax ordinance.

Section 2. The Clerk of Council is directed to certify a copy of this Resolution to the Board of Elections of Montgomery County and Miami County, Ohio, together with a copy of said Ordinance 2022-O-_____ and to take all steps necessary to place this issue on the ballot.

Section 3. The Board of Elections of Montgomery County and Miami County, Ohio, are directed to place on the ballot, in the election to be held on May 2, 2023 for submission to the electorate of the City of Huber Heights, the question of whether Ordinance No 2022-O-_____ shall be approved. The form of the ballot to be cast at such election shall read substantially as follows, subject to any required changes by the Secretary of State or Board of Elections:

Shall the Ordinance providing for the continuation of an existing .25% levy on income effective January 1, 2025, and expiring December 31, 2034, to provide for police and fire public safety and support be passed?

FOR THE INCOME TAX _____

AGAINST THE INCOME TAX _____

Section 4. It is hereby found and determined that all formal actions of this Council concerning and relating to the passage of this Resolution were adopted in an open meeting of this Council and that all deliberations of this Council and of any of its Committees that resulted in such formal action were taken in meetings open to the public and in conformance with all legal requirements including Section 121.22 of the Ohio Revised Code.

Section 5. This Resolution shall go into effect upon its passage as provided by law and the Charter of the City of Huber Heights.

Passed by Council on the ____ day of _____, 2022;
____ Yea; _____ Nays.

Effective Date:

AUTHENTICATION

Clerk of Council

Mayor

Date

Date

AI-8861

**New Business H.
City Manager**

City Council Special Meeting

Meeting Date: 12/15/2022

CRA #5 - Amendment

Submitted By: Bryan Chodkowski

Department: Economic Development

Council Committee Review?: Council Work Session
Date(s) of Committee Review: 12/06/2022

Audio-Visual Needs: None
Emergency Legislation?: No

**Motion/Ordinance/
Resolution No.:**

Agenda Item Description or Legislation Title

A Resolution Modifying Community Reinvestment Area #5 By Reducing The Boundaries Thereof.
(first reading)

Purpose and Background

This legislation modifies CRA District #5 by removing three (3) properties from the district. These parcels will be added to CRA District #7 under companion legislation.

Fiscal Impact

Source of Funds: N/A

Cost: N/A

Recurring Cost? (Yes/No): N/A

Funds Available in Current Budget? (Yes/No): N/A

Financial Implications:

Attachments

Resolution

Exhibit A

Exhibit B

CITY OF HUBER HEIGHTS
STATE OF OHIO

RESOLUTION NO. 2022-R-

MODIFYING COMMUNITY REINVESTMENT AREA #5 BY REDUCING THE BOUNDARIES THEREOF.

WHEREAS, Community Reinvestment Area (CRA) #5 was created on September 14, 1992 by Resolution No. 92-R-1139 which included a definition of the area encompassed by CRA #5; and

WHEREAS, CRA #5 was modified on September 28, 1993 via Resolution No. 93-R-1319; and

WHEREAS, the first amendment of CRA #5 occurred on June 26, 1995 via Resolution No. 95-R-1653; and

WHEREAS, a second amendment of CRA #5 occurred on September 28, 2015 via Resolution No. 2015-R-6232; and

WHEREAS, pursuant to Ohio Revised Code Section 3735.661(b) a modification of the CRA district that removes area from or decreases the geographic size of a community reinvestment area is not considered an amendment of the CRA; and

WHEREAS, the City wishes to modify CRA #5 in furtherance of its economic development and growth strategies to create a favorable environment with respect to the construction of new residential, commercial, and industrial facilities as well as the rehabilitation and expansion of existing residential, commercial, and industrial facilities.

NOW, THEREFORE, BE IT RESOLVED by the City Council of Huber Heights, Ohio, that:

Section 1. After due deliberation and consideration by Council for the City of Huber Heights, it is determined that the interests of the City are best served by the modification of CRA #5. CRA #5 shall now encompass those parcels as are referenced in the list attached hereto as Exhibit A which is incorporated herein and graphically represented as attached hereto as Exhibit B which is incorporated herein. This modification is in accordance with Ohio Revised Code Section 3735.661. The City Manager is hereby authorized to take whatever action is necessary to implement this legislation.

Section 2. Except as amended hereby, all other provisions of Resolution No. 92-R-1139 as amended and modified shall remain in full force and effect.

Section 3. A copy of this Resolution will be forwarded to the Miami and Montgomery County Auditors and the Director of the Ohio Development Services Agency by the City Manager for information and reference.

Section 4. It is hereby found and determined that all formal actions of this Council concerning and relating to the passage of this Resolution were adopted in an open meeting of this Council and that all deliberations of this Council and of any of its Committees that resulted in such formal action were in meetings open to the public and in compliance with all legal requirements including Section 121.22 of the Ohio Revised Code.

Section 5. This Resolution shall go into effect upon its passage as provided by law and the Charter of the City of Huber Heights.

Passed by Council on the _____ day of _____, 2022.
_____ Yeas; _____ Nays

Effective Date:

AUTHENTICATION:

Clerk of Council

Mayor

Date

Date

Exhibit A

PARCEL NUMBER	PARCEL LOCATION	ZONING CLASS	PROPOSED CHANGE
P70 03910 0055	8625 BRANDT PIKE	PM	CRA 5 to CRA 7
P70 03910 0056	8625 BRANDT PIKE	PM	CRA 5 to CRA 7
P70 03910 0061	7251 SHULL RD	PM	CRA 5 to CRA 7

Exhibit B

Proposed CRA 5 to CRA 7
Exist CRA Number
5

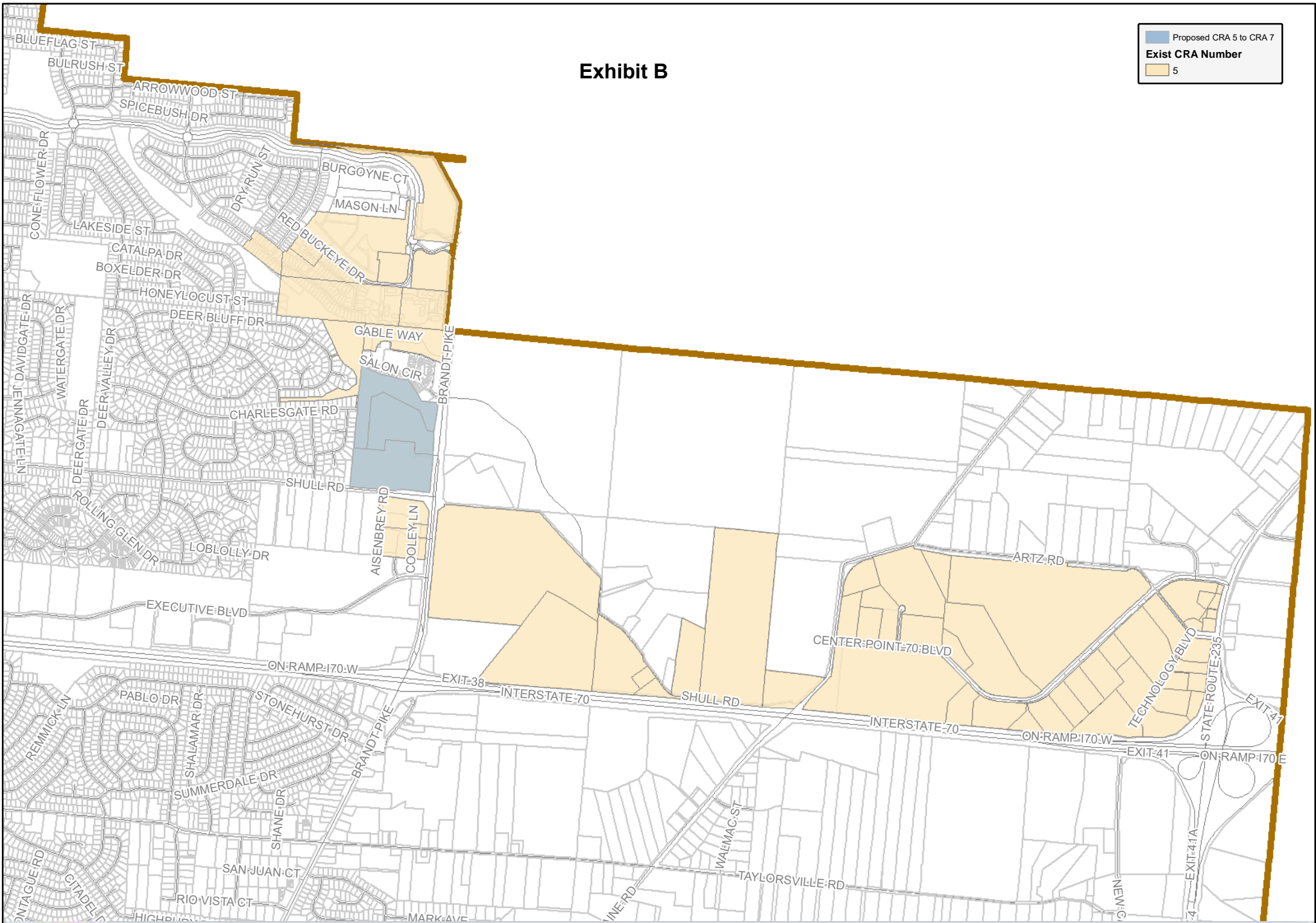

CITY OF HUBER HEIGHTS, OHIO



Date: 11/30/2022

AI-8862

**New Business I.
City Manager**

City Council Special Meeting

Meeting Date: 12/15/2022

CRA #7 - Amendment

Submitted By: Bryan Chodkowski

Department: Economic Development

Council Committee Review?: Council Work Session
Date(s) of Committee Review: 12/06/2022

Audio-Visual Needs: None
Emergency Legislation?: No

**Motion/Ordinance/
Resolution No.:**

Agenda Item Description or Legislation Title

A Resolution Providing For The Second And Final Amendment Of Community Reinvestment Area #7.
(first reading)

Purpose and Background

This second and final amendment to Community Reinvestment Area (CRA) #7 has been submitted for Council action in support of current and future economic development efforts. These efforts include the application of the CRA #7 to certain parcels as a condition of closing under approved development agreements (Homestead and Horizon Line) as well as parcels likely to be developed or in need of redevelopment in the future. Parcels determined as likely for development or redevelopment were based on previous inquires to the Department of Economic Development and by City Planner Aaron Sorrell.

Fiscal Impact

Source of Funds: N/A

Cost: N/A

Recurring Cost? (Yes/No): N/A

Funds Available in Current Budget? (Yes/No): N/A

Financial Implications:

Attachments

Resolution

Exhibit A

Exhibit B

CITY OF HUBER HEIGHTS
STATE OF OHIO

RESOLUTION NO. 2022-R-

PROVIDING FOR THE SECOND AND FINAL AMENDMENT OF COMMUNITY REINVESTMENT AREA #7.

WHEREAS, Community Reinvestment Area (CRA) #7 was created on June 20, 1994 by Resolution No. 94-R-1453 which included a definition of the area encompassed by CRA #7; and

WHEREAS, the first amendment of CRA #7 occurred on September 27, 2010 via Resolution No. 2010-R-5333; and

WHEREAS, CRA #7 was modified on June 8, 2015 via Resolution No. 2015-R-6195 and again on September 13, 2021 via Resolution No. 2021-R-7036 and neither of which constitute an amendment to the CRA under Ohio Revised Code Section 3735.661; and

WHEREAS, the City wishes to exercise the second amendment of CRA #7 in furtherance of its economic development and growth strategies to create a favorable environment with respect to the construction of new residential, commercial, and industrial facilities as well as the rehabilitation and expansion of existing residential, commercial, and industrial facilities.

NOW, THEREFORE, BE IT RESOLVED by the City Council of Huber Heights, Ohio, that:

Section 1. After due deliberation and consideration by Council for the City of Huber Heights, it is determined that the interests of the City are best served by exercising the second amendment of CRA #7. CRA #7 shall now encompass those parcels as are referenced in the list attached hereto as Exhibit A which are incorporated herein and graphically represented as attached hereto as Exhibit B which is incorporated herein. This second amendment is in accordance with Ohio Revised Code Section 3735.661. The City Manager is hereby authorized to take whatever action is necessary to implement this legislation.

Section 2: Resolution No. 94-R-1453, Section 3 is further amended to include the following provision after Section 3(c):

To grant any tax exemption for commercial or industrial structures under the foregoing paragraphs (b) or (c), the City and the owner of the property to be exempted must enter into an agreement. For purposes of Ohio Revised Code Section 3735.66 and this resolution, a structure composed of more than two residential units is classified as commercial property. The percentage of improvement exempted shall be the percentage set forth in the agreement if the structure or remodeling is to be used for commercial or industrial purposes or 100% if the structure or remodeling is to be used for residential purposes. The Housing Officer may require a pre-application for any exemption to ensure compatibility with neighborhood plans, to ensure the maintenance of existing streetscape lines, style, scale setbacks and landscaping features compatible with nearby properties and to coordinate the tax exemptions with other tax exemptions that apply to the property. The tax exemptions granted pursuant to this Resolution are subject and subordinate to tax exemptions granted pursuant to Ohio Revised Code Section 5709.40 or 5709.41 unless a different priority is designated by the Housing Officer in that officer's approval of a pre-application or final application for a tax exemption under this Resolution. Nothing in this Section shall be construed to require the City to approve a pre-application for any property or enter into an abatement agreement and grant the tax exemption provided hereunder for commercial and industrial property.

Section 3. Except as amended hereby, all other provisions of Resolution No. 94-R-1453 as previously amended and modified shall remain in full force and effect.

Section 4. A copy of this Resolution will be forwarded to the Miami and Montgomery County Auditors and the Director of the Ohio Development Services Agency by the City Manager for information and reference.

Section 5. It is hereby found and determined that all formal actions of this Council concerning and relating to the passage of this Resolution were adopted in an open meeting of this Council and that all deliberations of this Council and of any of its Committees that resulted in such formal action were in meetings open to the public and in compliance with all legal requirements including Section 121.22 of the Ohio Revised Code.

Section 6. This Resolution shall go into effect upon its passage as provided by law and the Charter of the City of Huber Heights.

Passed by Council on the ____ day of _____, 2022.
_____ Yeas; _____ Nays.

Effective Date:

AUTHENTICATION:

Clerk of Council

Mayor

Date

Date

Exhibit A

PARCEL NUMBER	PARCEL LOCATION	ZONING CLASS	PROPOSED CHANGE
P70 01919 0074	HILLTOP APTS/CONDOS	R-6	Add to CRA 7
P70 00405 0001	HILLTOP APTS/CONDOS	R-6	Add to CRA 7
P70 01921 0059	HILLTOP APTS/CONDOS	R-6	Add to CRA 7
P70 01920 0107	HILLTOP APTS/CONDOS	R-6	Add to CRA 7
P70 01920 0105	HILLTOP APTS/CONDOS	R-6	Add to CRA 7
P70 01920 0104	HILLTOP APTS/CONDOS	R-6	Add to CRA 7
P70 01921 0060	HILLTOP APTS/CONDOS	R-6	Add to CRA 7
P70 01920 0108	HILLTOP APTS/CONDOS	R-6	Add to CRA 7
P70 01919 0073	HILLTOP APTS/CONDOS	R-6	Add to CRA 7
P70 01920 0106	HILLTOP APTS/CONDOS	R-6	Add to CRA 7
P70 01919 0072	HILLTOP APTS/CONDOS	R-6	Add to CRA 7
P70 01919 0071	HILLTOP APTS/CONDOS	R-6	Add to CRA 7
P70 50206 0078	HILLTOP APTS/CONDOS	R-6	Add to CRA 7
P70 01920 0109	HILLTOP APTS/CONDOS	R-6	Add to CRA 7
P70 01920 0010	5970 CORBY WAY	R-6	Add to CRA 7
P70 01920 0012	5981 CORBY WAY	R-6	Add to CRA 7
P70 01920 0011	5978 CORBY WAY	R-6	Add to CRA 7
P70 01919 0041	7568 DALMATIAN DR	R-6	Add to CRA 7
P70 01919 0047	7622 DALMATIAN DR	R-6	Add to CRA 7
P70 01919 0045	7604 DALMATIAN DR	R-6	Add to CRA 7
P70 01919 0050	7641 DALMATIAN DR	R-6	Add to CRA 7
P70 01919 0053	7609 DALMATIAN DR	R-6	Add to CRA 7
P70 01919 0039	7550 DALMATIAN DR	R-6	Add to CRA 7
P70 01919 0044	7596 DALMATIAN DR	R-6	Add to CRA 7
P70 01919 0051	7633 DALMATIAN DR	R-6	Add to CRA 7
P70 01919 0055	7593 DALMATIAN DR	R-6	Add to CRA 7
P70 01919 0042	7578 DALMATIAN DR	R-6	Add to CRA 7
P70 01919 0056	7585 DALMATIAN DR	R-6	Add to CRA 7
P70 01919 0046	7614 DALMATIAN DR	R-6	Add to CRA 7
P70 01919 0054	7605 DALMATIAN DR	R-6	Add to CRA 7
P70 01919 0057	7569 DALMATIAN DR	R-6	Add to CRA 7
P70 01919 0048	7632 DALMATIAN DR	R-6	Add to CRA 7
P70 01919 0052	7623 DALMATIAN DR	R-6	Add to CRA 7
P70 01919 0049	7651 DALMATIAN DR	R-6	Add to CRA 7
P70 01919 0058	7553 DALMATIAN DR	R-6	Add to CRA 7
P70 01919 0043	7586 DALMATIAN DR	R-6	Add to CRA 7
P70 01919 0040	7560 DALMATIAN DR	R-6	Add to CRA 7
P70 01920 0037	8124 MOUNT CHARLES DR	R-6	Add to CRA 7
P70 01920 0038	8132 MOUNT CHARLES DR	R-6	Add to CRA 7
P70 01920 0039	8140 MOUNT CHARLES DR	R-6	Add to CRA 7
P70 01920 0044	8180 MOUNT CHARLES DR	R-6	Add to CRA 7
P70 01920 0043	8172 MOUNT CHARLES DR	R-6	Add to CRA 7
P70 01920 0034	8104 MOUNT CHARLES DR	R-6	Add to CRA 7
P70 01920 0045	8188 MOUNT CHARLES DR	R-6	Add to CRA 7
P70 01920 0046	8208 MOUNT CHARLES DR	R-6	Add to CRA 7
P70 01920 0035	8108 MOUNT CHARLES DR	R-6	Add to CRA 7
P70 01921 0053	8135 MOUNT CHARLES DR	R-6	Add to CRA 7
P70 01921 0051	8149 MOUNT CHARLES DR	R-6	Add to CRA 7
P70 01920 0041	8156 MOUNT CHARLES DR	R-6	Add to CRA 7
P70 01920 0027	8233 MOUNT CHARLES DR	R-6	Add to CRA 7
P70 01920 0023	8265 MOUNT CHARLES DR	R-6	Add to CRA 7
P70 01921 0050	8159 MOUNT CHARLES DR	R-6	Add to CRA 7
P70 01920 0047	8216 MOUNT CHARLES DR	R-6	Add to CRA 7
P70 01920 0029	8217 MOUNT CHARLES DR	R-6	Add to CRA 7
P70 01921 0054	8127 MOUNT CHARLES DR	R-6	Add to CRA 7
P70 01920 0030	8207 MOUNT CHARLES DR	R-6	Add to CRA 7
P70 01921 0056	8109 MOUNT CHARLES DR	R-6	Add to CRA 7
P70 01920 0036	8116 MOUNT CHARLES DR	R-6	Add to CRA 7
P70 01920 0040	8150 MOUNT CHARLES DR	R-6	Add to CRA 7
P70 01920 0028	8223 MOUNT CHARLES DR	R-6	Add to CRA 7

P70 01921 0055	8115 MOUNT CHARLES DR	R-6	Add to CRA 7
P70 01920 0025	8249 MOUNT CHARLES DR	R-6	Add to CRA 7
P70 01920 0042	8164 MOUNT CHARLES DR	R-6	Add to CRA 7
P70 01920 0024	8257 MOUNT CHARLES DR	R-6	Add to CRA 7
P70 01920 0026	8241 MOUNT CHARLES DR	R-6	Add to CRA 7
P70 01920 0048	8224 MOUNT CHARLES DR	R-6	Add to CRA 7
P70 01920 0031	8199 MOUNT CHARLES DR	R-6	Add to CRA 7
P70 01921 0052	8143 MOUNT CHARLES DR	R-6	Add to CRA 7
P70 00404 0001	7659 MOUNT HOOD DR	R-6	Add to CRA 7
P70 00404 0002	7759 MOUNT HOOD DR	R-6	Add to CRA 7
P70 01919 0060	7724 MOUNT HOOD DR	R-6	Add to CRA 7
P70 01919 0064	7810 MOUNT HOOD DR	R-6	Add to CRA 7
P70 01919 0061	7728 MOUNT HOOD DR	R-6	Add to CRA 7
P70 01920 0067	8119 MOUNT HOOD DR	R-6	Add to CRA 7
P70 01919 0069	8030 MOUNT HOOD DR	R-6	Add to CRA 7
P70 01920 0074	8179 MOUNT HOOD DR	R-6	Add to CRA 7
P70 01919 0063	7736 MOUNT HOOD DR	R-6	Add to CRA 7
P70 01920 0002	8070 MOUNT HOOD DR	R-6	Add to CRA 7
P70 01919 0066	7830 MOUNT HOOD DR	R-6	Add to CRA 7
P70 01920 0019	8186 MOUNT HOOD DR	R-6	Add to CRA 7
P70 01920 0017	8170 MOUNT HOOD DR	R-6	Add to CRA 7
P70 01920 0009	8128 MOUNT HOOD DR	R-6	Add to CRA 7
P70 01919 0002	7654 MOUNT HOOD DR	R-6	Add to CRA 7
P70 01920 0013	8138 MOUNT HOOD DR	R-6	Add to CRA 7
P70 01920 0022	8210 MOUNT HOOD DR	R-6	Add to CRA 7
P70 01920 0007	8110 MOUNT HOOD DR	R-6	Add to CRA 7
P70 01920 0069	8135 MOUNT HOOD DR	R-6	Add to CRA 7
P70 01920 0021	8202 MOUNT HOOD DR	R-6	Add to CRA 7
P70 01920 0015	8156 MOUNT HOOD DR	R-6	Add to CRA 7
P70 01920 0018	8178 MOUNT HOOD DR	R-6	Add to CRA 7
P70 01920 0068	8127 MOUNT HOOD DR	R-6	Add to CRA 7
P70 01921 0061	8038 MOUNT HOOD DR	R-6	Add to CRA 7
P70 50206 0048	7631 MOUNT HOOD DR	R-6	Add to CRA 7
P70 50007 0032	7626 MOUNT HOOD DR	R-6	Add to CRA 7
P70 50206 0069	7521 MOUNT HOOD DR	R-6	Add to CRA 7
P70 50206 0062	7571 MOUNT HOOD DR	R-6	Add to CRA 7
P70 50206 0021	7541 MOUNT HOOD DR	R-6	Add to CRA 7
P70 50007 0001	7554 MOUNT HOOD DR	R-6	Add to CRA 7
P70 50007 0008	7570 MOUNT HOOD DR	R-6	Add to CRA 7
P70 50206 0076	7505 MOUNT HOOD DR	R-6	Add to CRA 7
P70 01919 0067	7920 MOUNT HOOD DR	R-6	Add to CRA 7
P70 01919 0070	7646 MOUNT HOOD DR	R-6	Add to CRA 7
P70 01920 0066	8124 MOUNT HOOD DR	R-6	Add to CRA 7
P70 01920 0073	8169 MOUNT HOOD DR	R-6	Add to CRA 7
P70 01920 0065	8101 MOUNT HOOD DR	R-6	Add to CRA 7
P70 01920 0072	8163 MOUNT HOOD DR	R-6	Add to CRA 7
P70 01920 0064	8095 MOUNT HOOD DR	R-6	Add to CRA 7
P70 01920 0008	8120 MOUNT HOOD DR	R-6	Add to CRA 7
P70 01920 0003	8078 MOUNT HOOD DR	R-6	Add to CRA 7
P70 01920 0016	8162 MOUNT HOOD DR	R-6	Add to CRA 7
P70 01919 0062	7732 MOUNT HOOD DR	R-6	Add to CRA 7
P70 01920 0020	8194 MOUNT HOOD DR	R-6	Add to CRA 7
P70 01920 0006	8102 MOUNT HOOD DR	R-6	Add to CRA 7
P70 01921 0003	8054 MOUNT HOOD DR	R-6	Add to CRA 7
P70 01919 0068	8020 MOUNT HOOD DR	R-6	Add to CRA 7
P70 01920 0005	8094 MOUNT HOOD DR	R-6	Add to CRA 7
P70 01920 0004	8086 MOUNT HOOD DR	R-6	Add to CRA 7
P70 01920 0014	8146 MOUNT HOOD DR	R-6	Add to CRA 7
P70 01921 0002	8046 MOUNT HOOD DR	R-6	Add to CRA 7
P70 50206 0065	7525 MOUNT HOOD DR	R-6	Add to CRA 7
P70 50206 0040	7621 MOUNT HOOD DR	R-6	Add to CRA 7

P70 50206 0041	7623 MOUNT HOOD DR	R-6	Add to CRA 7
P70 50206 0059	7569 MOUNT HOOD DR	R-6	Add to CRA 7
P70 50206 0056	7563 MOUNT HOOD DR	R-6	Add to CRA 7
P70 50206 0058	7567 MOUNT HOOD DR	R-6	Add to CRA 7
P70 50206 0053	7587 MOUNT HOOD DR	R-6	Add to CRA 7
P70 50206 0052	7585 MOUNT HOOD DR	R-6	Add to CRA 7
P70 50206 0034	7607 MOUNT HOOD DR	R-6	Add to CRA 7
P70 50206 0031	7601 MOUNT HOOD DR	R-6	Add to CRA 7
P70 50206 0077	7609 MOUNT HOOD DR	R-6	Add to CRA 7
P70 50206 0032	7603 MOUNT HOOD DR	R-6	Add to CRA 7
P70 50007 0038	7634 MOUNT HOOD DR	R-6	Add to CRA 7
P70 01920 0075	8185 MOUNT HOOD DR	R-6	Add to CRA 7
P70 50007 0010	7570 MOUNT HOOD DR	R-6	Add to CRA 7
P70 50206 0055	7591 MOUNT HOOD DR	R-6	Add to CRA 7
P70 50206 0019	7541 MOUNT HOOD DR	R-6	Add to CRA 7
P70 50206 0060	7571 MOUNT HOOD DR	R-6	Add to CRA 7
P70 50206 0061	7573 MOUNT HOOD DR	R-6	Add to CRA 7
P70 50206 0047	7637 MOUNT HOOD DR	R-6	Add to CRA 7
P70 50206 0026	7557 MOUNT HOOD DR	R-6	Add to CRA 7
P70 50206 0018	7539 MOUNT HOOD DR	R-6	Add to CRA 7
P70 50206 0067	7521 MOUNT HOOD DR	R-6	Add to CRA 7
P70 50206 0037	7615 MOUNT HOOD DR	R-6	Add to CRA 7
P70 50206 0075	7503 MOUNT HOOD DR	R-6	Add to CRA 7
P70 50007 0004	7556 MOUNT HOOD DR	R-6	Add to CRA 7
P70 50007 0019	7590 MOUNT HOOD DR	R-6	Add to CRA 7
P70 50206 0015	7533 MOUNT HOOD DR	R-6	Add to CRA 7
P70 50007 0028	7610 MOUNT HOOD DR	R-6	Add to CRA 7
P70 50007 0002	7552 MOUNT HOOD DR	R-6	Add to CRA 7
P70 50206 0054	7589 MOUNT HOOD DR	R-6	Add to CRA 7
P70 50206 0064	7527 MOUNT HOOD DR	R-6	Add to CRA 7
P70 50206 0022	7549 MOUNT HOOD DR	R-6	Add to CRA 7
P70 50007 0041	7640 MOUNT HOOD DR	R-6	Add to CRA 7
P70 50206 0024	7553 MOUNT HOOD DR	R-6	Add to CRA 7
P70 50007 0013	7576 MOUNT HOOD DR	R-6	Add to CRA 7
P70 50007 0003	7554 MOUNT HOOD DR	R-6	Add to CRA 7
P70 50007 0035	7626 MOUNT HOOD DR	R-6	Add to CRA 7
P70 50007 0016	7584 MOUNT HOOD DR	R-6	Add to CRA 7
P70 50007 0039	7636 MOUNT HOOD DR	R-6	Add to CRA 7
P70 50007 0034	7624 MOUNT HOOD DR	R-6	Add to CRA 7
P70 50206 0027	7559 MOUNT HOOD DR	R-6	Add to CRA 7
P70 50206 0044	7631 MOUNT HOOD DR	R-6	Add to CRA 7
P70 50007 0026	7606 MOUNT HOOD DR	R-6	Add to CRA 7
P70 50007 0042	7642 MOUNT HOOD DR	R-6	Add to CRA 7
P70 50007 0030	7616 MOUNT HOOD DR	R-6	Add to CRA 7
P70 01921 0001	8038 MOUNT HOOD DR	R-6	Add to CRA 7
P70 50206 0057	7565 MOUNT HOOD DR	R-6	Add to CRA 7
P70 01920 0001	8062 MOUNT HOOD DR	R-6	Add to CRA 7
P70 50206 0051	7583 MOUNT HOOD DR	R-6	Add to CRA 7
P70 01919 0065	7820 MOUNT HOOD DR	R-6	Add to CRA 7
P70 50206 0023	7551 MOUNT HOOD DR	R-6	Add to CRA 7
P70 01919 0059	7720 MOUNT HOOD DR	R-6	Add to CRA 7
P70 01919 0001	7650 MOUNT HOOD DR	R-6	Add to CRA 7
P70 50206 0036	7613 MOUNT HOOD DR	R-6	Add to CRA 7
P70 50206 0033	7605 MOUNT HOOD DR	R-6	Add to CRA 7
P70 50206 0050	7581 MOUNT HOOD DR	R-6	Add to CRA 7
P70 50206 0016	7535 MOUNT HOOD DR	R-6	Add to CRA 7
P70 50007 0018	7588 MOUNT HOOD DR	R-6	Add to CRA 7
P70 50206 0020	7543 MOUNT HOOD DR	R-6	Add to CRA 7
P70 50206 0071	7511 MOUNT HOOD DR	R-6	Add to CRA 7
P70 50007 0012	7574 MOUNT HOOD DR	R-6	Add to CRA 7
P70 50206 0066	7523 MOUNT HOOD DR	R-6	Add to CRA 7

P70 50007 0014	7578 MOUNT HOOD DR	R-6	Add to CRA 7
P70 50007 0029	7614 MOUNT HOOD DR	R-6	Add to CRA 7
P70 50007 0040	7638 MOUNT HOOD DR	R-6	Add to CRA 7
P70 50007 0024	7602 MOUNT HOOD DR	R-6	Add to CRA 7
P70 50007 0006	7560 MOUNT HOOD DR	R-6	Add to CRA 7
P70 50007 0020	7592 MOUNT HOOD DR	R-6	Add to CRA 7
P70 50007 0033	7622 MOUNT HOOD DR	R-6	Add to CRA 7
P70 50206 0028	7595 MOUNT HOOD DR	R-6	Add to CRA 7
P70 50206 0073	7507 MOUNT HOOD DR	R-6	Add to CRA 7
P70 50206 0049	7579 MOUNT HOOD DR	R-6	Add to CRA 7
P70 50206 0017	7537 MOUNT HOOD DR	R-6	Add to CRA 7
P70 50206 0074	7505 MOUNT HOOD DR	R-6	Add to CRA 7
P70 50206 0025	7555 MOUNT HOOD DR	R-6	Add to CRA 7
P70 50206 0045	7633 MOUNT HOOD DR	R-6	Add to CRA 7
P70 50007 0025	7604 MOUNT HOOD DR	R-6	Add to CRA 7
P70 50007 0009	7568 MOUNT HOOD DR	R-6	Add to CRA 7
P70 50007 0036	7630 MOUNT HOOD DR	R-6	Add to CRA 7
P70 50206 0063	7529 MOUNT HOOD DR	R-6	Add to CRA 7
P70 50007 0031	7618 MOUNT HOOD DR	R-6	Add to CRA 7
P70 50206 0042	7627 MOUNT HOOD DR	R-6	Add to CRA 7
P70 50206 0030	7599 MOUNT HOOD DR	R-6	Add to CRA 7
P70 50206 0046	7635 MOUNT HOOD DR	R-6	Add to CRA 7
P70 50206 0072	7509 MOUNT HOOD DR	R-6	Add to CRA 7
P70 50206 0035	7611 MOUNT HOOD DR	R-6	Add to CRA 7
P70 50007 0015	7582 MOUNT HOOD DR	R-6	Add to CRA 7
P70 50206 0070	7513 MOUNT HOOD DR	R-6	Add to CRA 7
P70 50206 0029	7597 MOUNT HOOD DR	R-6	Add to CRA 7
P70 50206 0068	7519 MOUNT HOOD DR	R-6	Add to CRA 7
P70 50206 0039	7619 MOUNT HOOD DR	R-6	Add to CRA 7
P70 50206 0043	7624 MOUNT HOOD DR	R-6	Add to CRA 7
P70 50007 0037	7632 MOUNT HOOD DR	R-6	Add to CRA 7
P70 50007 0007	7562 MOUNT HOOD DR	R-6	Add to CRA 7
P70 50007 0017	7586 MOUNT HOOD DR	R-6	Add to CRA 7
P70 50007 0005	7558 MOUNT HOOD DR	R-6	Add to CRA 7
P70 50007 0011	7572 MOUNT HOOD DR	R-6	Add to CRA 7
P70 50007 0023	7600 MOUNT HOOD DR	R-6	Add to CRA 7
P70 50206 0038	7617 MOUNT HOOD DR	R-6	Add to CRA 7
P70 50007 0021	7594 MOUNT HOOD DR	R-6	Add to CRA 7
P70 50007 0027	7608 MOUNT HOOD DR	R-6	Add to CRA 7
P70 01920 0076	8195 MOUNT HOOD DR	R-6	Add to CRA 7
P70 01920 0071	8155 MOUNT HOOD DR	R-6	Add to CRA 7
P70 01920 0070	8147 MOUNT HOOD DR	R-6	Add to CRA 7
P70 50007 0022	7598 MOUNT HOOD DR	R-6	Add to CRA 7
P70 50007 0043	MOUNT HOOD DR	R-6	Add to CRA 7
P70 01921 0034	8231 MOUNT MANSFIELD DR	R-6	Add to CRA 7
P70 01921 0040	8177 MOUNT MANSFIELD DR	R-6	Add to CRA 7
P70 01921 0049	8196 MOUNT MANSFIELD DR	R-6	Add to CRA 7
P70 01921 0039	8185 MOUNT MANSFIELD DR	R-6	Add to CRA 7
P70 01921 0038	8199 MOUNT MANSFIELD DR	R-6	Add to CRA 7
P70 01921 0037	8207 MOUNT MANSFIELD DR	R-6	Add to CRA 7
P70 01921 0047	8178 MOUNT MANSFIELD DR	R-6	Add to CRA 7
P70 01921 0043	8161 MOUNT MANSFIELD DR	R-6	Add to CRA 7
P70 01921 0035	8223 MOUNT MANSFIELD DR	R-6	Add to CRA 7
P70 01921 0042	8165 MOUNT MANSFIELD DR	R-6	Add to CRA 7
P70 01921 0045	8127 MOUNT MANSFIELD DR	R-6	Add to CRA 7
P70 01921 0046	8170 MOUNT MANSFIELD DR	R-6	Add to CRA 7
P70 01921 0041	8169 MOUNT MANSFIELD DR	R-6	Add to CRA 7
P70 01921 0048	8188 MOUNT MANSFIELD DR	R-6	Add to CRA 7
P70 01921 0044	8152 MOUNT MANSFIELD DR	R-6	Add to CRA 7
P70 01921 0036	8215 MOUNT MANSFIELD DR	R-6	Add to CRA 7
P70 01921 0027	8200 MOUNT MCKINLEY DR	R-6	Add to CRA 7

P70 01921 0031	8254 MOUNT MCKINLEY DR	R-6	Add to CRA 7
P70 01921 0014	8175 MOUNT MCKINLEY DR	R-6	Add to CRA 7
P70 01921 0022	8158 MOUNT MCKINLEY DR	R-6	Add to CRA 7
P70 01921 0015	8167 MOUNT MCKINLEY DR	R-6	Add to CRA 7
P70 01921 0011	8217 MOUNT MCKINLEY DR	R-6	Add to CRA 7
P70 01921 0006	8247 MOUNT MCKINLEY DR	R-6	Add to CRA 7
P70 01920 0032	8285 MOUNT MCKINLEY DR	R-6	Add to CRA 7
P70 01921 0057	8211 MOUNT MCKINLEY DR	R-6	Add to CRA 7
P70 01921 0058	8131 MOUNT MCKINLEY DR	R-6	Add to CRA 7
P70 01921 0009	8225 MOUNT MCKINLEY DR	R-6	Add to CRA 7
P70 01920 0033	8277 MOUNT MCKINLEY DR	R-6	Add to CRA 7
P70 01921 0025	8184 MOUNT MCKINLEY DR	R-6	Add to CRA 7
P70 01921 0029	8238 MOUNT MCKINLEY DR	R-6	Add to CRA 7
P70 01921 0012	8211 MOUNT MCKINLEY DR	R-6	Add to CRA 7
P70 01921 0007	8239 MOUNT MCKINLEY DR	R-6	Add to CRA 7
P70 01921 0028	8230 MOUNT MCKINLEY DR	R-6	Add to CRA 7
P70 01921 0017	8149 MOUNT MCKINLEY DR	R-6	Add to CRA 7
P70 01921 0024	8176 MOUNT MCKINLEY DR	R-6	Add to CRA 7
P70 01921 0004	8265 MOUNT MCKINLEY DR	R-6	Add to CRA 7
P70 01921 0021	8148 MOUNT MCKINLEY DR	R-6	Add to CRA 7
P70 01921 0008	8229 MOUNT MCKINLEY DR	R-6	Add to CRA 7
P70 01921 0016	8155 MOUNT MCKINLEY DR	R-6	Add to CRA 7
P70 01921 0030	8248 MOUNT MCKINLEY DR	R-6	Add to CRA 7
P70 01921 0013	8205 MOUNT MCKINLEY DR	R-6	Add to CRA 7
P70 01921 0033	8274 MOUNT MCKINLEY DR	R-6	Add to CRA 7
P70 01921 0026	8192 MOUNT MCKINLEY DR	R-6	Add to CRA 7
P70 01921 0020	8140 MOUNT MCKINLEY DR	R-6	Add to CRA 7
P70 01921 0005	8257 MOUNT MCKINLEY DR	R-6	Add to CRA 7
P70 01921 0023	8166 MOUNT MCKINLEY DR	R-6	Add to CRA 7
P70 01921 0018	8139 MOUNT MCKINLEY DR	R-6	Add to CRA 7
P70 01921 0010	8221 MOUNT MCKINLEY DR	R-6	Add to CRA 7
P70 01921 0032	8266 MOUNT MCKINLEY DR	R-6	Add to CRA 7
P70 01921 0019	8131 MOUNT MCKINLEY DR	R-6	Add to CRA 7
P70 50105 0027	7539 MOUNT RAINIER DR	R-6	Add to CRA 7
P70 50105 0037	7509 MOUNT RAINIER DR	R-6	Add to CRA 7
P70 50105 0036	7521 MOUNT RAINIER DR	R-6	Add to CRA 7
P70 50105 0001	7506 MOUNT RAINIER DR	R-6	Add to CRA 7
P70 50105 0044	MOUNT RAINIER DR	R-6	Add to CRA 7
P70 50105 0012	7524 MOUNT RAINIER DR	R-6	Add to CRA 7
P70 50105 0003	7504 MOUNT RAINIER DR	R-6	Add to CRA 7
P70 50105 0011	7522 MOUNT RAINIER DR	R-6	Add to CRA 7
P70 50105 0024	7543 MOUNT RAINIER DR	R-6	Add to CRA 7
P70 50105 0010	7520 MOUNT RAINIER DR	R-6	Add to CRA 7
P70 50105 0019	7540 MOUNT RAINIER DR	R-6	Add to CRA 7
P70 50105 0014	7528 MOUNT RAINIER DR	R-6	Add to CRA 7
P70 50105 0023	7545 MOUNT RAINIER DR	R-6	Add to CRA 7
P70 50105 0034	7521 MOUNT RAINIER DR	R-6	Add to CRA 7
P70 50105 0033	7523 MOUNT RAINIER DR	R-6	Add to CRA 7
P70 50105 0020	7542 MOUNT RAINIER DR	R-6	Add to CRA 7
P70 50105 0039	7509 MOUNT RAINIER DR	R-6	Add to CRA 7
P70 50105 0041	7505 MOUNT RAINIER DR	R-6	Add to CRA 7
P70 50105 0022	7547 MOUNT RAINIER DR	R-6	Add to CRA 7
P70 50105 0031	7527 MOUNT RAINIER DR	R-6	Add to CRA 7
P70 50105 0040	7507 MOUNT RAINIER DR	R-6	Add to CRA 7
P70 50105 0035	7519 MOUNT RAINIER DR	R-6	Add to CRA 7
P70 50105 0008	7516 MOUNT RAINIER DR	R-6	Add to CRA 7
P70 50105 0042	7503 MOUNT RAINIER DR	R-6	Add to CRA 7
P70 50105 0029	7531 MOUNT RAINIER DR	R-6	Add to CRA 7
P70 50105 0032	7525 MOUNT RAINIER DR	R-6	Add to CRA 7
P70 50105 0028	7535 MOUNT RAINIER DR	R-6	Add to CRA 7
P70 50105 0026	7539 MOUNT RAINIER DR	R-6	Add to CRA 7

P70 50105 0043	7501 MOUNT RAINER DR	R-6	Add to CRA 7
P70 50105 0005	7508 MOUNT RAINER DR	R-6	Add to CRA 7
P70 50105 0017	7536 MOUNT RAINER DR	R-6	Add to CRA 7
P70 50105 0025	7441 MOUNT RAINER DR	R-6	Add to CRA 7
P70 50105 0016	7534 MOUNT RAINER DR	R-6	Add to CRA 7
P70 50105 0004	7506 MOUNT RAINER DR	R-6	Add to CRA 7
P70 50105 0006	7510 MOUNT RAINER DR	R-6	Add to CRA 7
P70 50105 0015	7532 MOUNT RAINER DR	R-6	Add to CRA 7
P70 50105 0009	7518 MOUNT RAINER DR	R-6	Add to CRA 7
P70 50105 0013	7526 MOUNT RAINER DR	R-6	Add to CRA 7
P70 50105 0021	7544 MOUNT RAINER DR	R-6	Add to CRA 7
P70 50105 0038	7511 MOUNT RAINER DR	R-6	Add to CRA 7
P70 50105 0007	7512 MOUNT RAINER DR	R-6	Add to CRA 7
P70 50105 0018	7538 MOUNT RAINER DR	R-6	Add to CRA 7
P70 50105 0002	7502 MOUNT RAINER DR	R-6	Add to CRA 7
P70 50105 0030	7529 MOUNT RAINER DR	R-6	Add to CRA 7
P70 01920 0102	8139 MOUNT SNOW DR	R-6	Add to CRA 7
P70 01920 0088	8100 MOUNT SNOW DR	R-6	Add to CRA 7
P70 01920 0087	8106 MOUNT SNOW DR	R-6	Add to CRA 7
P70 01920 0083	8142 MOUNT SNOW DR	R-6	Add to CRA 7
P70 01920 0086	8118 MOUNT SNOW DR	R-6	Add to CRA 7
P70 01920 0097	8181 MOUNT SNOW DR	R-6	Add to CRA 7
P70 01920 0085	8124 MOUNT SNOW DR	R-6	Add to CRA 7
P70 01920 0099	8165 MOUNT SNOW DR	R-6	Add to CRA 7
P70 01920 0082	8150 MOUNT SNOW DR	R-6	Add to CRA 7
P70 01920 0100	8157 MOUNT SNOW DR	R-6	Add to CRA 7
P70 01920 0078	8180 MOUNT SNOW DR	R-6	Add to CRA 7
P70 01920 0103	8133 MOUNT SNOW DR	R-6	Add to CRA 7
P70 01920 0081	8158 MOUNT SNOW DR	R-6	Add to CRA 7
P70 01920 0101	8151 MOUNT SNOW DR	R-6	Add to CRA 7
P70 01920 0084	8132 MOUNT SNOW DR	R-6	Add to CRA 7
P70 01920 0098	8171 MOUNT SNOW DR	R-6	Add to CRA 7
P70 01920 0080	8164 MOUNT SNOW DR	R-6	Add to CRA 7
P70 01920 0079	8172 MOUNT SNOW DR	R-6	Add to CRA 7
P70 01920 0054	8173 MOUNT WASHINGTON DR	R-6	Add to CRA 7
P70 01920 0062	8109 MOUNT WASHINGTON DR	R-6	Add to CRA 7
P70 01920 0061	8117 MOUNT WASHINGTON DR	R-6	Add to CRA 7
P70 01920 0063	8101 MOUNT WASHINGTON DR	R-6	Add to CRA 7
P70 01920 0056	8157 MOUNT WASHINGTON DR	R-6	Add to CRA 7
P70 01920 0091	8139 MOUNT WASHINGTON DR	R-6	Add to CRA 7
P70 01920 0077	8206 MOUNT WASHINGTON DR	R-6	Add to CRA 7
P70 01920 0096	8190 MOUNT WASHINGTON DR	R-6	Add to CRA 7
P70 01920 0059	8135 MOUNT WASHINGTON DR	R-6	Add to CRA 7
P70 01920 0089	8120 MOUNT WASHINGTON DR	R-6	Add to CRA 7
P70 01920 0060	8125 MOUNT WASHINGTON DR	R-6	Add to CRA 7
P70 01920 0094	8158 MOUNT WASHINGTON DR	R-6	Add to CRA 7
P70 01920 0057	8149 MOUNT WASHINGTON DR	R-6	Add to CRA 7
P70 01920 0092	8142 MOUNT WASHINGTON DR	R-6	Add to CRA 7
P70 01920 0095	8166 MOUNT WASHINGTON DR	R-6	Add to CRA 7
P70 01920 0050	8205 MOUNT WASHINGTON DR	R-6	Add to CRA 7
P70 01920 0053	8181 MOUNT WASHINGTON DR	R-6	Add to CRA 7
P70 01920 0058	8141 MOUNT WASHINGTON DR	R-6	Add to CRA 7
P70 01920 0055	8167 MOUNT WASHINGTON DR	R-6	Add to CRA 7
P70 01920 0093	8150 MOUNT WASHINGTON DR	R-6	Add to CRA 7
P70 01920 0049	8209 MOUNT WASHINGTON DR	R-6	Add to CRA 7
P70 01920 0090	8134 MOUNT WASHINGTON DR	R-6	Add to CRA 7
P70 01920 0052	8189 MOUNT WASHINGTON DR	R-6	Add to CRA 7
P70 01920 0051	8197 MOUNT WASHINGTON DR	R-6	Add to CRA 7
P70 00812 0001	7530 MOUNT WHITNEY ST	R-6	Add to CRA 7
P70 01919 0003	7500 POMERANIAN DR	R-6	Add to CRA 7
P70 01919 0030	7631 POMERANIAN DR	R-6	Add to CRA 7

P70 01919 0032	7615 POMERANIAN DR	R-6	Add to CRA 7
P70 01919 0029	7639 POMERANIAN DR	R-6	Add to CRA 7
P70 01919 0035	7589 POMERANIAN DR	R-6	Add to CRA 7
P70 01919 0020	7640 POMERANIAN DR	R-6	Add to CRA 7
P70 01919 0031	7621 POMERANIAN DR	R-6	Add to CRA 7
P70 01919 0023	7666 POMERANIAN DR	R-6	Add to CRA 7
P70 01919 0036	7579 POMERANIAN DR	R-6	Add to CRA 7
P70 01919 0025	7684 POMERANIAN DR	R-6	Add to CRA 7
P70 01919 0010	7556 POMERANIAN DR	R-6	Add to CRA 7
P70 01919 0007	7532 POMERANIAN DR	R-6	Add to CRA 7
P70 01919 0028	7649 POMERANIAN DR	R-6	Add to CRA 7
P70 01919 0021	7648 POMERANIAN DR	R-6	Add to CRA 7
P70 01919 0009	7548 POMERANIAN DR	R-6	Add to CRA 7
P70 01919 0012	7572 POMERANIAN DR	R-6	Add to CRA 7
P70 01919 0033	7605 POMERANIAN DR	R-6	Add to CRA 7
P70 01919 0022	7658 POMERANIAN DR	R-6	Add to CRA 7
P70 01919 0015	7596 POMERANIAN DR	R-6	Add to CRA 7
P70 01919 0018	7622 POMERANIAN DR	R-6	Add to CRA 7
P70 01919 0006	7524 POMERANIAN DR	R-6	Add to CRA 7
P70 01919 0034	7597 POMERANIAN DR	R-6	Add to CRA 7
P70 01919 0038	7531 POMERANIAN DR	R-6	Add to CRA 7
P70 01919 0004	7508 POMERANIAN DR	R-6	Add to CRA 7
P70 01919 0026	7675 POMERANIAN DR	R-6	Add to CRA 7
P70 01919 0011	7564 POMERANIAN DR	R-6	Add to CRA 7
P70 01919 0017	7612 POMERANIAN DR	R-6	Add to CRA 7
P70 01919 0016	7604 POMERANIAN DR	R-6	Add to CRA 7
P70 01919 0019	7630 POMERANIAN DR	R-6	Add to CRA 7
P70 01919 0037	7539 POMERANIAN DR	R-6	Add to CRA 7
P70 01919 0013	7580 POMERANIAN DR	R-6	Add to CRA 7
P70 01919 0008	7540 POMERANIAN DR	R-6	Add to CRA 7
P70 01919 0027	7665 POMERANIAN DR	R-6	Add to CRA 7
P70 01919 0024	7676 POMERANIAN DR	R-6	Add to CRA 7
P70 01919 0014	7588 POMERANIAN DR	R-6	Add to CRA 7
P70 01919 0005	7516 POMERANIAN DR	R-6	Add to CRA 7
P70 50206 0001	5857 TAYLORSVILLE RD	R-6	Add to CRA 7
P70 50206 0007	5853 TAYLORSVILLE RD	R-6	Add to CRA 7
P70 50206 0002	5851 TAYLORSVILLE RD	R-6	Add to CRA 7
P70 50206 0012	5879 TAYLORSVILLE RD	R-6	Add to CRA 7
P70 50206 0013	5875 TAYLORSVILLE RD	R-6	Add to CRA 7
P70 50206 0008	5877 TAYLORSVILLE RD	R-6	Add to CRA 7
P70 50206 0010	5867 TAYLORSVILLE RD	R-6	Add to CRA 7
P70 50206 0003	5855 TAYLORSVILLE RD	R-6	Add to CRA 7
P70 50206 0014	5873 TAYLORSVILLE RD	R-6	Add to CRA 7
P70 50206 0009	5869 TAYLORSVILLE RD	R-6	Add to CRA 7
P70 50206 0004	5859 TAYLORSVILLE RD	R-6	Add to CRA 7
P70 50206 0011	5871 TAYLORSVILLE RD	R-6	Add to CRA 7
P70 50206 0005	5863 TAYLORSVILLE RD	R-6	Add to CRA 7
P70 50206 0006	5861 TAYLORSVILLE RD	R-6	Add to CRA 7
P70 04005 0006	6025 TAYLORSVILLE RD	R-4	Add to CRA 7
P70 04005 0023	6109 TAYLORSVILLE RD	PP	Add to CRA 7
P70 04005 0127	6111 TAYLORSVILLE RD	PP	Add to CRA 7
P70 04005 0024	6121 TAYLORSVILLE RD	PP	Add to CRA 7
P70 04005 0130	7325 OLD TROY PIKE	PC	Add to CRA 7
P70 04005 0131	7345 OLD TROY PIKE	PC	Add to CRA 7
P70 04005 0009	7477 OLD TROY PIKE	PC	Add to CRA 7
P70 01122 0001	5376 TAYLORSVILLE RD	PC	Add to CRA 7
P70 04003 0145	HILLTOP APTS/CONDOS	R-6	Add to CRA 7
P70 04003 0147	4792 FISHBURG RD	R-4	Add to CRA 7
P70 04003 0062	4788 FISHBURG RD	R-4	Add to CRA 7
P70 04003 0149	4788 FISHBURG RD	R-4	Add to CRA 7
P70 04003 0008	4752 FISHBURG RD	B-1	Add to CRA 7

P70 04003 0118	4750 FISHBURG RD	B-1	Add to CRA 7
P70 04003 0011	4850 FISHBURG RD	R-4	Add to CRA 7
P70 04003 0104	4704 FISHBURG RD	B-1	Add to CRA 7
P70 04003 0109	4782 FISHBURG RD	B-1	Add to CRA 7
P70 04003 0123	4882 FISHBURG RD	R-4	Add to CRA 7
P70 04003 0113	4792 FISHBURG RD	R-4	Add to CRA 7
P70 04003 0010	4840 FISHBURG RD	R-4	Add to CRA 7
P70 04003 0013	4882 FISHBURG RD	R-4	Add to CRA 7
P70 04003 0154	4830 FISHBURG RD	R-4	Add to CRA 7
P70 04003 0122	4882 FISHBURG RD	R-4	Add to CRA 7
P70 04003 0012	4866 FISHBURG RD	R-4	Add to CRA 7
P70 04003 0061	4876 FISHBURG RD	R-4	Add to CRA 7
P70 02021 0009	5985 FOX TRACE CT	R-4	Add to CRA 7
P70 02021 0010	5995 FOX TRACE CT	R-4	Add to CRA 7
P70 02021 0006	5955 FOX TRACE CT	R-4	Add to CRA 7
P70 02021 0001	5990 FOX TRACE CT	R-4	Add to CRA 7
P70 02021 0008	5975 FOX TRACE CT	R-4	Add to CRA 7
P70 02021 0003	5970 FOX TRACE CT	R-4	Add to CRA 7
P70 02021 0005	5950 FOX TRACE CT	R-4	Add to CRA 7
P70 02021 0007	5965 FOX TRACE CT	R-4	Add to CRA 7
P70 02021 0004	5960 FOX TRACE CT	R-4	Add to CRA 7
P70 02021 0002	5980 FOX TRACE CT	R-4	Add to CRA 7
P70 04003 0015	4743 PENNSWOOD DR	R-6	Add to CRA 7
P70 51323 0030	BIRD DOG CT	R-5	Add to CRA 7
P70 51323 0110	4217 BIRD DOG CT	R-5	Add to CRA 7
P70 51323 0029	4229 BIRD DOG CT	R-5	Add to CRA 7
P70 51323 0109	4215 BIRD DOG CT	R-5	Add to CRA 7
P70 51323 0111	BIRD DOG CT	R-5	Add to CRA 7
P70 51323 0028	4227 BIRD DOG CT	R-5	Add to CRA 7
P70 51323 0024	BIRD DOG CT	R-5	Add to CRA 7
P70 51323 0020	4181 BIRD DOG CT	R-5	Add to CRA 7
P70 51323 0025	4203 BIRD DOG CT	R-5	Add to CRA 7
P70 51323 0027	BIRD DOG CT	R-5	Add to CRA 7
P70 51323 0023	4193 BIRD DOG CT	R-5	Add to CRA 7
P70 51323 0021	BIRD DOG CT	R-5	Add to CRA 7
P70 51323 0022	4191 BIRD DOG CT	R-5	Add to CRA 7
P70 51323 0019	4179 BIRD DOG CT	R-5	Add to CRA 7
P70 51323 0026	4205 BIRD DOG CT	R-5	Add to CRA 7
P70 51323 0038	4200 BIRD DOG CT	R-5	Add to CRA 7
P70 51323 0040	4210 BIRD DOG CT	R-5	Add to CRA 7
P70 51323 0043	4174 BIRD DOG CT	R-5	Add to CRA 7
P70 51323 0042	BIRD DOG CT	R-5	Add to CRA 7
P70 51323 0048	BIRD DOG CT	R-5	Add to CRA 7
P70 51323 0045	BIRD DOG CT	R-5	Add to CRA 7
P70 51323 0037	4198 BIRD DOG CT	R-5	Add to CRA 7
P70 51323 0039	BIRD DOG CT	R-5	Add to CRA 7
P70 51323 0041	4212 BIRD DOG CT	R-5	Add to CRA 7
P70 51323 0044	4176 BIRD DOG CT	R-5	Add to CRA 7
P70 51323 0046	4186 BIRD DOG CT	R-5	Add to CRA 7
P70 51323 0047	4188 BIRD DOG CT	R-5	Add to CRA 7
P70 51323 0034	4224 BIRD DOG CT	R-5	Add to CRA 7
P70 51323 0036	BIRD DOG CT	R-5	Add to CRA 7
P70 51323 0035	4222 BIRD DOG CT	R-5	Add to CRA 7
P70 51323 0032	4234 BIRD DOG CT	R-5	Add to CRA 7
P70 51323 0033	BIRD DOG CT	R-5	Add to CRA 7
P70 51323 0031	4232 BIRD DOG CT	R-5	Add to CRA 7
P70 00418 0003	5297 COCO DR	R-5	Add to CRA 7
P70 00418 0009	5256 COCO DR	R-5	Add to CRA 7
P70 00418 0004	5296 COCO DR	R-5	Add to CRA 7
P70 00418 0014	5287 COCO DR	R-5	Add to CRA 7
P70 00418 0005	5288 COCO DR	R-5	Add to CRA 7

P70 00418 0016	5257 COCO DR	R-5	Add to CRA 7
P70 00418 0015	5255 COCO DR	R-5	Add to CRA 7
P70 50424 0010	5273 COCO DR	R-5	Add to CRA 7
P70 50424 0008	5263 COCO DR	R-5	Add to CRA 7
P70 50424 0009	5271 COCO DR	R-5	Add to CRA 7
P70 50424 0024	5281 COCO DR	R-5	Add to CRA 7
P70 50424 0011	5279 COCO DR	R-5	Add to CRA 7
P70 50424 0012	5281 COCO DR	R-5	Add to CRA 7
P70 50424 0023	5279 COCO DR	R-5	Add to CRA 7
P70 50424 0019	5261 COCO DR	R-5	Add to CRA 7
P70 50424 0022	5273 COCO DR	R-5	Add to CRA 7
P70 50424 0020	5263 COCO DR	R-5	Add to CRA 7
P70 50424 0021	5271 COCO DR	R-5	Add to CRA 7
P70 50424 0007	5261 COCO DR	R-5	Add to CRA 7
P70 50424 0005	5266 COCO DR	R-5	Add to CRA 7
P70 50424 0018	5264 COCO DR	R-5	Add to CRA 7
P70 50424 0001	5282 COCO DR	R-5	Add to CRA 7
P70 50424 0002	5280 COCO DR	R-5	Add to CRA 7
P70 50424 0004	5272 COCO DR	R-5	Add to CRA 7
P70 50424 0014	5280 COCO DR	R-5	Add to CRA 7
P70 50424 0017	5266 COCO DR	R-5	Add to CRA 7
P70 50424 0003	5274 COCO DR	R-5	Add to CRA 7
P70 50424 0015	5274 COCO DR	R-5	Add to CRA 7
P70 50424 0016	5272 COCO DR	R-5	Add to CRA 7
P70 50424 0013	5282 COCO DR	R-5	Add to CRA 7
P70 50424 0006	5264 COCO DR	R-5	Add to CRA 7
P70 04003 0116	5245 OLD TROY PIKE	A	Add to CRA 7
P70 04003 0044	5191 OLD TROY PIKE	A	Add to CRA 7
P70 51323 0086	4185 PHEASANT CT	R-5	Add to CRA 7
P70 51323 0049	4173 PHEASANT CT	R-5	Add to CRA 7
P70 51323 0051	PHEASANT CT	R-5	Add to CRA 7
P70 51323 0089	4199 PHEASANT CT	R-5	Add to CRA 7
P70 51323 0050	4175 PHEASANT CT	R-5	Add to CRA 7
P70 51323 0087	PHEASANT CT	R-5	Add to CRA 7
P70 51323 0120	PHEASANT CT	R-5	Add to CRA 7
P70 51323 0118	4209 PHEASANT CT	R-5	Add to CRA 7
P70 51323 0088	4197 PHEASANT CT	R-5	Add to CRA 7
P70 51323 0090	PHEASANT CT	R-5	Add to CRA 7
P70 51323 0119	4211 PHEASANT CT	R-5	Add to CRA 7
P70 51323 0085	4187 PHEASANT CT	R-5	Add to CRA 7
P70 51323 0077	4221 PHEASANT CT	R-5	Add to CRA 7
P70 51323 0070	4176 PHEASANT CT	R-5	Add to CRA 7
P70 51323 0072	PHEASANT CT	R-5	Add to CRA 7
P70 51323 0067	4188 PHEASANT CT	R-5	Add to CRA 7
P70 51323 0068	4190 PHEASANT CT	R-5	Add to CRA 7
P70 51323 0073	4214 PHEASANT CT	R-5	Add to CRA 7
P70 51323 0076	4219 PHEASANT CT	R-5	Add to CRA 7
P70 51323 0078	PHEASANT CT	R-5	Add to CRA 7
P70 51323 0069	PHEASANT CT	R-5	Add to CRA 7
P70 51323 0083	4166 PHEASANT CT	R-5	Add to CRA 7
P70 51323 0074	4212 PHEASANT CT	R-5	Add to CRA 7
P70 51323 0075	PHEASANT CT	R-5	Add to CRA 7
P70 51323 0082	4164 PHEASANT CT	R-5	Add to CRA 7
P70 51323 0084	PHEASANT CT	R-5	Add to CRA 7
P70 51323 0117	PHEASANT CT	R-5	Add to CRA 7
P70 51323 0116	4202 PHEASANT CT	R-5	Add to CRA 7
P70 51323 0115	4200 PHEASANT CT	R-5	Add to CRA 7
P70 51323 0071	4178 PHEASANT CT	R-5	Add to CRA 7
P70 04003 0051	4280 POWELL RD	R-1	Add to CRA 7
P70 04003 0053	4286 POWELL RD	R-1	Add to CRA 7
P70 04007 0003	POWELL RD	R-1	Add to CRA 7

P70 04003 0050	4290 POWELL RD	PP	Add to CRA 7
P70 04003 0052	4344 POWELL RD	R-1	Add to CRA 7
P70 04003 0059	4286 POWELL RD	R-1	Add to CRA 7
P70 04003 0055	4290 POWELL RD	R-1	Add to CRA 7
P70 04003 0054	4328 POWELL RD	R-1	Add to CRA 7
P70 04003 0231	4370 POWELL RD	R-4	Add to CRA 7
P70 04003 0056	4366 POWELL RD	R-1	Add to CRA 7
P70 04003 0156	4316 POWELL RD	R-1	Add to CRA 7
P70 04003 0043	4316 POWELL RD	R-1	Add to CRA 7
P70 04003 0081	4400 POWELL RD	R-4	Add to CRA 7
P70 04003 0233	4410 POWELL RD	PP	Add to CRA 7
P70 04003 0110	4400 POWELL RD	PP	Add to CRA 7
P70 51323 0121	VITEK DR	R-5	Add to CRA 7
P70 04003 0167	VITEK DR	R-5	Add to CRA 7
P70 00418 0002	4269 VITEK DR	R-5	Add to CRA 7
P70 00418 0001	4279 VITEK DR	R-5	Add to CRA 7
P70 51323 0079	4071 VITEK DR	R-5	Add to CRA 7
P70 51323 0080	4069 VITEK DR	R-5	Add to CRA 7
P70 51323 0081	VITEK DR	R-5	Add to CRA 7
P70 51323 0095	4095 VITEK DR	R-5	Add to CRA 7
P70 51323 0096	VITEK DR	R-5	Add to CRA 7
P70 51323 0092	4083 VITEK DR	R-5	Add to CRA 7
P70 51323 0093	VITEK DR	R-5	Add to CRA 7
P70 51323 0098	4107 VITEK DR	R-5	Add to CRA 7
P70 51323 0099	VITEK DR	R-5	Add to CRA 7
P70 51323 0094	4093 VITEK DR	R-5	Add to CRA 7
P70 51323 0091	4081 VITEK DR	R-5	Add to CRA 7
P70 51323 0097	4105 VITEK DR	R-5	Add to CRA 7
P70 51323 0104	4131 VITEK DR	R-5	Add to CRA 7
P70 51323 0101	4117 VITEK DR	R-5	Add to CRA 7
P70 51323 0107	4141 VITEK DR	R-5	Add to CRA 7
P70 51323 0108	VITEK DR	R-5	Add to CRA 7
P70 51323 0102	VITEK DR	R-5	Add to CRA 7
P70 51323 0106	4143 VITEK DR	R-5	Add to CRA 7
P70 51323 0105	VITEK DR	R-5	Add to CRA 7
P70 51323 0100	4119 VITEK DR	R-5	Add to CRA 7
P70 51323 0103	4129 VITEK DR	R-5	Add to CRA 7
P70 51323 0053	4215 VITEK DR	R-5	Add to CRA 7
P70 51323 0123	4179 VITEK DR	R-5	Add to CRA 7
P70 51323 0062	4203 VITEK DR	R-5	Add to CRA 7
P70 51323 0058	4189 VITEK DR	R-5	Add to CRA 7
P70 51323 0052	4213 VITEK DR	R-5	Add to CRA 7
P70 51323 0054	VITEK DR	R-5	Add to CRA 7
P70 51323 0061	4201 VITEK DR	R-5	Add to CRA 7
P70 51323 0059	4191 VITEK DR	R-5	Add to CRA 7
P70 51323 0060	VITEK DR	R-5	Add to CRA 7
P70 51323 0124	VITEK DR	R-5	Add to CRA 7
P70 51323 0063	VITEK DR	R-5	Add to CRA 7
P70 51323 0122	4177 VITEK DR	R-5	Add to CRA 7
P70 51323 0066	VITEK DR	R-5	Add to CRA 7
P70 51323 0065	4239 VITEK DR	R-5	Add to CRA 7
P70 51323 0055	4225 VITEK DR	R-5	Add to CRA 7
P70 51323 0057	VITEK DR	R-5	Add to CRA 7
P70 51323 0112	4251 VITEK DR	R-5	Add to CRA 7
P70 51323 0114	VITEK DR	R-5	Add to CRA 7
P70 51323 0056	4227 VITEK DR	R-5	Add to CRA 7
P70 51323 0113	4249 VITEK DR	R-5	Add to CRA 7
P70 51323 0064	4237 VITEK DR	R-5	Add to CRA 7
P70 51323 0013	4196 VITEK DR	R-5	Add to CRA 7
P70 51323 0007	4220 VITEK DR	R-5	Add to CRA 7
P70 51323 0005	4210 VITEK DR	R-5	Add to CRA 7

P70 51323 0016	4184 VITEK DR	R-5	Add to CRA 7
P70 51323 0014	4198 VITEK DR	R-5	Add to CRA 7
P70 51323 0006	VITEK DR	R-5	Add to CRA 7
P70 51323 0015	VITEK DR	R-5	Add to CRA 7
P70 51323 0004	4208 VITEK DR	R-5	Add to CRA 7
P70 51323 0017	4186 VITEK DR	R-5	Add to CRA 7
P70 51323 0018	VITEK DR	R-5	Add to CRA 7
P70 51323 0008	4222 VITEK DR	R-5	Add to CRA 7
P70 51323 0009	VITEK DR	R-5	Add to CRA 7
P70 51323 0010	4234 VITEK DR	R-5	Add to CRA 7
P70 51323 0002	4244 VITEK DR	R-5	Add to CRA 7
P70 51323 0001	4246 VITEK DR	R-5	Add to CRA 7
P70 51323 0003	VITEK DR	R-5	Add to CRA 7
P70 51323 0012	VITEK DR	R-5	Add to CRA 7
P70 51323 0011	4232 VITEK DR	R-5	Add to CRA 7
P70 51431 0041	8839 LYON ST	PM	Add to CRA 7
P70 51431 0026	8836 LYON ST	PM	Add to CRA 7
P70 51431 0025	8838 LYON ST	PM	Add to CRA 7
P70 51431 0028	8832 LYON ST	PM	Add to CRA 7
P70 51431 0029	LYON ST	PM	Add to CRA 7
P70 51431 0038	8833 LYON ST	PM	Add to CRA 7
P70 51431 0040	8837 LYON ST	PM	Add to CRA 7
P70 51431 0039	8835 LYON ST	PM	Add to CRA 7
P70 51431 0037	8841 LYON ST	PM	Add to CRA 7
P70 51431 0027	8834 LYON ST	PM	Add to CRA 7
P70 51431 0042	LYON ST	PM	Add to CRA 7
P70 00320 0012	MONTE CARLO WAY	PM	Add to CRA 7
P70 00320 0018	MONTE CARLO WAY	PM	Add to CRA 7
P70 00320 0020	MONTE CARLO WAY	PM	Add to CRA 7
P70 51431 0035	6988 MONTE CARLO WAY	PM	Add to CRA 7
P70 51431 0033	6996 MONTE CARLO WAY	PM	Add to CRA 7
P70 51431 0032	6998 MONTE CARLO WAY	PM	Add to CRA 7
P70 51431 0034	6990 MONTE CARLO WAY	PM	Add to CRA 7
P70 51431 0031	6994 MONTE CARLO WAY	PM	Add to CRA 7
P70 51431 0030	6992 MONTE CARLO WAY	PM	Add to CRA 7
P70 51431 0036	MONTE CARLO WAY	PM	Add to CRA 7
P70 00320 0001	7002 SALON CIR	PM	Add to CRA 7
P70 00320 0011	SALON CIR	PM	Add to CRA 7
P70 00320 0010	SALON CIR	PM	Add to CRA 7
P70 00320 0016	SALON CIR	PM	Add to CRA 7
P70 00320 0019	SALON CIR	PM	Add to CRA 7
P70 00320 0014	SALON CIR	PM	Add to CRA 7
P70 00320 0017	SALON CIR	PM	Add to CRA 7
P70 51431 0011	6993 SALON CIR	PM	Add to CRA 7
P70 51431 0013	6991 SALON CIR	PM	Add to CRA 7
P70 51431 0003	8823 SALON CIR	PM	Add to CRA 7
P70 51431 0014	6989 SALON CIR	PM	Add to CRA 7
P70 51431 0009	8837 SALON CIR	PM	Add to CRA 7
P70 51431 0008	8835 SALON CIR	PM	Add to CRA 7
P70 51431 0012	6995 SALON CIR	PM	Add to CRA 7
P70 51442 0006	6950 SALON CIR	PM	Add to CRA 7
P70 51442 0004	6958 SALON CIR	PM	Add to CRA 7
P70 51442 0001	6962 SALON CIR	PM	Add to CRA 7
P70 51431 0023	6986 SALON CIR	PM	Add to CRA 7
P70 51442 0002	6966 SALON CIR	PM	Add to CRA 7
P70 51431 0018	6990 SALON CIR	PM	Add to CRA 7
P70 51431 0010	SALON CIR	PM	Add to CRA 7
P70 51431 0007	8833 SALON CIR	PM	Add to CRA 7
P70 51431 0022	6996 SALON CIR	PM	Add to CRA 7
P70 51431 0046	6978 SALON CIR	PM	Add to CRA 7
P70 51431 0006	8831 SALON CIR	PM	Add to CRA 7

P70 51431 0044	6970 SALON CIR	PM	Add to CRA 7
P70 51431 0019	6998 SALON CIR	PM	Add to CRA 7
P70 51431 0017	7000 SALON CIR	PM	Add to CRA 7
P70 51431 0043	6976 SALON CIR	PM	Add to CRA 7
P70 51431 0002	8825 SALON CIR	PM	Add to CRA 7
P70 51431 0020	6994 SALON CIR	PM	Add to CRA 7
P70 51431 0001	8827 SALON CIR	PM	Add to CRA 7
P70 51442 0007	SALON CIR	PM	Add to CRA 7
P70 51431 0016	6988 SALON CIR	PM	Add to CRA 7
P70 51431 0004	8821 SALON CIR	PM	Add to CRA 7
P70 51442 0005	SALON CIR	PM	Add to CRA 7
P70 51431 0015	SALON CIR	PM	Add to CRA 7
P70 51431 0024	SALON CIR	PM	Add to CRA 7
P70 51431 0047	SALON CIR	PM	Add to CRA 7
P70 51431 0005	SALON CIR	PM	Add to CRA 7
P70 51442 0003	6958 SALON CIR	PM	Add to CRA 7
P70 51431 0045	6976 SALON CIR	PM	Add to CRA 7
P70 51431 0021	6992 SALON CIR	PM	Add to CRA 7
P70 03910 0005	7125 EXECUTIVE BLVD	PEP	Add to CRA 7
P70 01820 0004	EXECUTIVE BLVD	PEP	Add to CRA 7
P70 01820 0003	EXECUTIVE BLVD	PEP	Add to CRA 7
P70 03910 0015	7070 SHULL RD	R-2	Add to CRA 7
P70 03910 0042	7230 SHULL RD	A	Add to CRA 7
P70 03910 0017	7130 SHULL RD	A	Add to CRA 7
P70 03910 0004	7190 SHULL RD	A	Add to CRA 7
P70 03910 0044	7240 SHULL RD	A	Add to CRA 7
P70 03910 0026	7000 SHULL RD	A	Add to CRA 7
P70 03910 0016	7110 SHULL RD	A	Add to CRA 7
P70 03910 0025	7050 SHULL RD	A	Add to CRA 7
P70 03910 0014	7000 SHULL RD	A	Add to CRA 7
P70 03910 0012	8245 BRANDT PIKE	PEP	Add to CRA 7
P70 03910 0031	8001 BRANDT PIKE	B-3	Add to CRA 7
P70 03910 0063	EXECUTIVE BLVD	PEP	Add to CRA 7
P70 03910 0062	EXECUTIVE BLVD	PEP	Add to CRA 7
P70 01820 0009	6800 EXECUTIVE BLVD	PEP	Add to CRA 7
P70 01820 0008	6800 EXECUTIVE BLVD	PEP	Add to CRA 7
P70 01820 0007	6800 EXECUTIVE BLVD	PEP	Add to CRA 7
P70 01820 0005	7150 EXECUTIVE BLVD	PEP	Add to CRA 7
P70 01820 0010	6800 EXECUTIVE BLVD	PEP	Add to CRA 7
P70 01820 0012	7050 EXECUTIVE BLVD	PM	Add to CRA 7
P70 01820 0014	7000 EXECUTIVE BLVD	PM	Add to CRA 7
P70 01820 0013	6900 EXECUTIVE BLVD	PEP	Add to CRA 7
P70 03909 0001	7789 BRANDT PIKE	PC	Add to CRA 7
P70 03909 0155	7901 BRANDT PIKE	B-3	Add to CRA 7
P70 03909 0156	7911 BRANDT PIKE	B-3	Add to CRA 7
P70 03909 0157	7907 BRANDT PIKE	B-3	Add to CRA 7
P70 03909 0123	7889 BRANDT PIKE	B-3	Add to CRA 7
P70 02005 0002	7213 TAYLORSVILLE RD	B-3	Add to CRA 7
P70 02005 0004	7227 TAYLORSVILLE RD	B-3	Add to CRA 7
P70 02005 0001	7211 TAYLORSVILLE RD	B-1	Add to CRA 7
P70 51101 0009	7229 TAYLORSVILLE RD	B-3	Add to CRA 7
P70 51101 0005	7231 TAYLORSVILLE RD	B-3	Add to CRA 7
P70 51101 0007	7231 TAYLORSVILLE RD	B-3	Add to CRA 7
P70 51101 0014	7229 TAYLORSVILLE RD	B-3	Add to CRA 7
P70 51101 0011	7229 TAYLORSVILLE RD	B-3	Add to CRA 7
P70 51101 0008	7229 TAYLORSVILLE RD	B-3	Add to CRA 7
P70 51101 0001	7231 TAYLORSVILLE RD	B-3	Add to CRA 7
P70 51101 0012	7229 TAYLORSVILLE RD	B-3	Add to CRA 7
P70 51101 0004	7231 TAYLORSVILLE RD	B-3	Add to CRA 7
P70 51101 0010	7229 TAYLORSVILLE RD	B-3	Add to CRA 7
P70 51101 0003	7231 TAYLORSVILLE RD	B-3	Add to CRA 7

P70 51101 0006	7231 TAYLORSVILLE RD	B-3	Add to CRA 7
P70 51101 0013	7229 TAYLORSVILLE RD	B-3	Add to CRA 7
P70 51101 0015	7231 TAYLORSVILLE RD	B-3	Add to CRA 7
P70 51101 0002	7231 TAYLORSVILLE RD	B-3	Add to CRA 7
P70 03909 0061	7101 TAYLORSVILLE RD	PC	Add to CRA 7
P70 03909 0143	7201 TAYLORSVILLE RD	B-1	Add to CRA 7
P70 03909 0136	7213 TAYLORSVILLE RD	PC	Add to CRA 7
P70 03909 0004	7217 TAYLORSVILLE RD	B-1	Add to CRA 7
P70 01003 0013	7200 TAYLORSVILLE RD	PC	Add to CRA 7
P70 03909 0182	7508 BRANDT PIKE	B-1	Add to CRA 7
P70 03909 0016	7405 TAYLORSVILLE RD	B-1	Add to CRA 7
P70 03909 0015	7373 TAYLORSVILLE RD	R-4	Add to CRA 7
P70 03909 0110	BRANDT PIKE	B-1	Add to CRA 7
P70 01017 0001	7480 BRANDT PIKE	B-1	Add to CRA 7
P70 03909 0012	7480 BRANDT PIKE	B-1	Add to CRA 7
P70 01017 0002	7460 BRANDT PIKE	B-1	Add to CRA 7
P70 03909 0013	7320 TAYLORSVILLE RD	B-2	Add to CRA 7
P70 03909 0018	7450 TAYLORSVILLE RD	A	Add to CRA 7
P70 03909 0019	7450 TAYLORSVILLE RD	A	Add to CRA 7
P70 03909 0017	7450 TAYLORSVILLE RD	PP	Add to CRA 7
P70 03909 0014	7340 TAYLORSVILLE RD	B-2	Add to CRA 7
P70 03909 0088	7450 TAYLORSVILLE RD	PP	Add to CRA 7
P70 03909 0108	7950 TAYLORSVILLE RD	A	Add to CRA 7
P70 03909 0114	7650 TAYLORSVILLE RD	R-2	Add to CRA 7
P70 03909 0112	7780 TAYLORSVILLE RD	A	Add to CRA 7
P70 03909 0106	TAYLORSVILLE RD	A	Add to CRA 7
P70 03909 0023	7570 TAYLORSVILLE RD	A	Add to CRA 7
P70 03909 0084	7570 TAYLORSVILLE RD	A	Add to CRA 7
P70 03909 0072	7570 TAYLORSVILLE RD	A	Add to CRA 7
P70 03909 0032	7950 TAYLORSVILLE RD	A	Add to CRA 7
P70 03909 0073	7688 TAYLORSVILLE RD	R-2	Add to CRA 7
P70 03909 0033	7730 TAYLORSVILLE RD	PP	Add to CRA 7
P70 03909 0107	TAYLORSVILLE RD	A	Add to CRA 7
P70 03909 0122	7550 TAYLORSVILLE RD	A	Add to CRA 7
P70 03909 0034	7570 TAYLORSVILLE RD	A	Add to CRA 7
P70 02114 0002	7754 BRANDT PIKE	PC	Add to CRA 7
P70 02114 0001	7680 BRANDT PIKE	PC	Add to CRA 7
P70 02114 0003	7730 BRANDT PIKE	PC	Add to CRA 7
P70 02114 0004	7670 BRANDT PIKE	PC	Add to CRA 7
P70 02114 0005	BRANDT PIKE	PC	Add to CRA 7
P70 03909 0002	7700 BRANDT PIKE	PC	Add to CRA 7
P70 03909 0113	7888 BRANDT PIKE	B-3	Add to CRA 7
P70 03909 0148	7800 BRANDT PIKE	B-3	Add to CRA 7
P70 03909 0059	7820 CEDAR HILL DR	A	Add to CRA 7
P70 03909 0085	7860 CEDAR HILL DR	PC	Add to CRA 7
P70 03909 0060	7840 CEDAR HILL DR	A	Add to CRA 7
P70 03909 0056	7860 CEDAR HILL DR	PC	Add to CRA 7
P70 03909 0026	7900 CEDAR HILL DR	B-3	Add to CRA 7
P70 03909 0029	CEDAR HILL DR	PC	Add to CRA 7
P70 03909 0069	7860 CEDAR HILL DR	PC	Add to CRA 7
P70 03909 0099	7888 CEDAR HILL DR	B-3	Add to CRA 7
P70 03909 0027	7880 CEDAR HILL DR	PC	Add to CRA 7
P70 03909 0070	7860 CEDAR HILL DR	PC	Add to CRA 7
P70 03909 0028	CEDAR HILL DR	PC	Add to CRA 7
P70 03909 0053	7447 TAYLORSVILLE RD	A	Add to CRA 7
P70 02208 0001	7505 TAYLORSVILLE RD	PP	Add to CRA 7
P70 03909 0049	7625 TAYLORSVILLE RD	R-1	Add to CRA 7
P70 03909 0121	7575 TAYLORSVILLE RD	R-1	Add to CRA 7
P70 03909 0030	7677 TAYLORSVILLE RD	R-1	Add to CRA 7
P70 03909 0111	7835 TAYLORSVILLE RD	R-2	Add to CRA 7
P70 03909 0051	7575 TAYLORSVILLE RD	R-1	Add to CRA 7

P70 03909 0031	7835 TAYLORSVILLE RD	A	Add to CRA 7
P70 03909 0058	7459 TAYLORSVILLE RD	A	Add to CRA 7
P70 03909 0119	7835 TAYLORSVILLE RD	R-2	Add to CRA 7
P70 03909 0048	7801 TAYLORSVILLE RD	R-1	Add to CRA 7
P70 03909 0055	7447 TAYLORSVILLE RD	A	Add to CRA 7
P70 03909 0074	7735 TAYLORSVILLE RD	R-1	Add to CRA 7
P70 03909 0118	7777 TAYLORSVILLE RD	R-1	Add to CRA 7
P70 00311 0001	HILLTOP APTS/CONDOS	R-6	Add to CRA 7
P70 50704 0021	6807 BARBARA DR	R-6	Add to CRA 7
P70 50704 0030	6851 BARBARA DR	R-6	Add to CRA 7
P70 50704 0029	6851 BARBARA DR	R-6	Add to CRA 7
P70 50704 0007	6851 BARBARA DR	R-6	Add to CRA 7
P70 50704 0018	6851 BARBARA DR	R-6	Add to CRA 7
P70 50704 0027	6851 BARBARA DR	R-6	Add to CRA 7
P70 50704 0033	6851 BARBARA DR	R-6	Add to CRA 7
P70 50704 0025	6851 BARBARA DR	R-6	Add to CRA 7
P70 50704 0026	6851 BARBARA DR	R-6	Add to CRA 7
P70 50704 0031	6851 BARBARA DR	R-6	Add to CRA 7
P70 50704 0039	6851 BARBARA DR	R-6	Add to CRA 7
P70 50704 0011	6851 BARBARA DR	R-6	Add to CRA 7
P70 50704 0008	6851 BARBARA DR	R-6	Add to CRA 7
P70 50704 0019	6851 BARBARA DR	R-6	Add to CRA 7
P70 50704 0001	6851 BARBARA DR	R-6	Add to CRA 7
P70 50704 0013	6851 BARBARA DR	R-6	Add to CRA 7
P70 50704 0016	6851 BARBARA DR	R-6	Add to CRA 7
P70 50704 0036	6851 BARBARA DR	R-6	Add to CRA 7
P70 50704 0010	6851 BARBARA DR	R-6	Add to CRA 7
P70 50704 0005	6851 BARBARA DR	R-6	Add to CRA 7
P70 50704 0006	6851 BARBARA DR	R-6	Add to CRA 7
P70 50704 0012	6851 BARBARA DR	R-6	Add to CRA 7
P70 50704 0004	6851 BARBARA DR	R-6	Add to CRA 7
P70 50704 0002	6851 BARBARA DR	R-6	Add to CRA 7
P70 50704 0035	6851 BARBARA DR	R-6	Add to CRA 7
P70 50704 0003	6851 BARBARA DR	R-6	Add to CRA 7
P70 50704 0020	6851 BARBARA DR	R-6	Add to CRA 7
P70 50704 0034	6851 BARBARA DR	R-6	Add to CRA 7
P70 50704 0023	6851 BARBARA DR	R-6	Add to CRA 7
P70 50704 0014	6851 BARBARA DR	R-6	Add to CRA 7
P70 50704 0038	6851 BARBARA DR	R-6	Add to CRA 7
P70 50704 0022	6851 BARBARA DR	R-6	Add to CRA 7
P70 50704 0037	6851 BARBARA DR	R-6	Add to CRA 7
P70 50704 0028	6851 BARBARA DR	R-6	Add to CRA 7
P70 50704 0024	6851 BARBARA DR	R-6	Add to CRA 7
P70 50704 0017	6851 BARBARA DR	R-6	Add to CRA 7
P70 50704 0015	6851 BARBARA DR	R-6	Add to CRA 7
P70 50704 0032	6851 BARBARA DR	R-6	Add to CRA 7
P70 50704 0009	6777 BARBARA DR	R-6	Add to CRA 7
P70 50704 0053	BARBARA DR	R-6	Add to CRA 7
P70 02010 0007	6805 BRANDT PIKE	R-6	Add to CRA 7
P70 50704 0051	6973 BRANDT PIKE	R-6	Add to CRA 7
P70 50704 0042	6961 BRANDT PIKE	R-6	Add to CRA 7
P70 50704 0041	6957 BRANDT PIKE	R-6	Add to CRA 7
P70 50704 0052	6975 BRANDT PIKE	R-6	Add to CRA 7
P70 50704 0043	6959 BRANDT PIKE	R-6	Add to CRA 7
P70 50704 0049	6971 BRANDT PIKE	R-6	Add to CRA 7
P70 50704 0046	6851 BRANDT PIKE	R-6	Add to CRA 7
P70 50704 0050	6851 BRANDT PIKE	R-6	Add to CRA 7
P70 50704 0048	6851 BRANDT PIKE	R-6	Add to CRA 7
P70 50704 0047	6851 BRANDT PIKE	R-6	Add to CRA 7
P70 50704 0045	6851 BRANDT PIKE	R-6	Add to CRA 7
P70 50704 0044	6851 BRANDT PIKE	R-6	Add to CRA 7

P70 50704 0040	6851 BRANDT PIKE	R-6	Add to CRA 7
P70 02010 0001	6002 LEYDEN LN	R-6	Add to CRA 7
P70 02010 0003	5602 LEYDEN LN	R-6	Add to CRA 7
P70 02010 0002	5806 LEYDEN LN	R-6	Add to CRA 7
P70 02010 0005	5402 LEYDEN LN	R-6	Add to CRA 7
P70 02010 0006	5200 LEYDEN LN	R-6	Add to CRA 7
P70 02010 0004	LEYDEN LN	R-6	Add to CRA 7
P70 00605 0001	6951 MAROSE DR	R-6	Add to CRA 7
P70 02011 0001	6797 BRANDT PIKE	R-6	Add to CRA 7
P70 02011 0003	5313 LEYDEN LN	R-6	Add to CRA 7
P70 50909 0003	5513 LEYDEN LN	R-6	Add to CRA 7
P70 50909 0020	5905 LEYDEN LN	R-6	Add to CRA 7
P70 50909 0026	6109 LEYDEN LN	R-6	Add to CRA 7
P70 50909 0005	5509 LEYDEN LN	R-6	Add to CRA 7
P70 50909 0004	5507 LEYDEN LN	R-6	Add to CRA 7
P70 50909 0002	5503 LEYDEN LN	R-6	Add to CRA 7
P70 50909 0019	5905 LEYDEN LN	R-6	Add to CRA 7
P70 50909 0008	5515 LEYDEN LN	R-6	Add to CRA 7
P70 02011 0002	5101 LEYDEN LN	R-6	Add to CRA 7
P70 50909 0011	5703 LEYDEN LN	R-6	Add to CRA 7
P70 50909 0015	5711 LEYDEN LN	R-6	Add to CRA 7
P70 50909 0028	6109 LEYDEN LN	R-6	Add to CRA 7
P70 50909 0022	5911 LEYDEN LN	R-6	Add to CRA 7
P70 50909 0013	5707 LEYDEN LN	R-6	Add to CRA 7
P70 50909 0027	6107 LEYDEN LN	R-6	Add to CRA 7
P70 50909 0025	6103 LEYDEN LN	R-6	Add to CRA 7
P70 50909 0001	5501 LEYDEN LN	R-6	Add to CRA 7
P70 50909 0018	5903 LEYDEN LN	R-6	Add to CRA 7
P70 50909 0024	6101 LEYDEN LN	R-6	Add to CRA 7
P70 50909 0010	5701 LEYDEN LN	R-6	Add to CRA 7
P70 50909 0007	5513 LEYDEN LN	R-6	Add to CRA 7
P70 50909 0014	5709 LEYDEN LN	R-6	Add to CRA 7
P70 50909 0017	5901 LEYDEN LN	R-6	Add to CRA 7
P70 50909 0006	5511 LEYDEN LN	R-6	Add to CRA 7
P70 50909 0029	6111 LEYDEN LN	R-6	Add to CRA 7
P70 50909 0012	5705 LEYDEN LN	R-6	Add to CRA 7
P70 50909 0021	5909 LEYDEN LN	R-6	Add to CRA 7
P70 50909 0023	LEYDEN LN	R-6	Add to CRA 7
P70 50909 0030	LEYDEN LN	R-6	Add to CRA 7
P70 50909 0016	LEYDEN LN	R-6	Add to CRA 7
P70 50909 0009	LEYDEN LN	R-6	Add to CRA 7
P70 03912 0134	6500 BRANDT PIKE	PC	Add to CRA 7
P70 03912 0061	6441 CHAMBERSBURG RD	B-1	Add to CRA 7
P70 03912 0022	6488 CHAMBERSBURG RD	B-1	Add to CRA 7
P70 03912 0015	6460 CHAMBERSBURG RD	PC	Add to CRA 7
P70 03908 0030	6500 CHAMBERSBURG RD	R-1	Add to CRA 7
P70 03912 0058	6430 CHAMBERSBURG RD	B-1	Add to CRA 7
P70 03912 0081	6418 CHAMBERSBURG RD	B-1	Add to CRA 7
P70 03912 0080	6422 CHAMBERSBURG RD	B-2	Add to CRA 7
P70 03912 0109	6428 CHAMBERSBURG RD	PP	Add to CRA 7
P70 00205 0016	6000 CHANNING WAY CT	R-5	Add to CRA 7
P70 02004 0006	KITTYHAWK COMMONS BLVD	PC	Add to CRA 7
P70 02004 0004	KITTYHAWK COMMONS BLVD	PC	Add to CRA 7
P70 00205 0002	KITTYHAWK COMMONS BLVD	PC	Add to CRA 7
P70 02004 0006	KITTYHAWK COMMONS BLVD	PC	Add to CRA 7
P70 02004 0005	KITTYHAWK COMMONS BLVD	PC	Add to CRA 7
P70 02004 0003	6373 KITTYHAWK COMMONS BLVD	PC	Add to CRA 7
P70 02004 0002	6371 KITTYHAWK COMMONS BLVD	PC	Add to CRA 7
	KITTYHAWK COMMONS BLVD	PR	Add to CRA 7
	KITTYHAWK COMMONS BLVD	PR	Add to CRA 7
	KITTYHAWK COMMONS BLVD	PR	Add to CRA 7

P70 02015 0008	6495 BRANDT PIKE	PC	Add to CRA 7
P70 03912 0141	6243 BRANDT PIKE	PM	Add to CRA 7
P70 03912 0043	FISHBURG RD	PP	Add to CRA 7
P70 03912 0017	FISHBURG RD	B-3	Add to CRA 7
P70 03912 0040	FISHBURG RD	PP	Add to CRA 7
P70 01418 0001	5367 FISHBURG RD	PP	Add to CRA 7
P70 03912 0045	FISHBURG RD	PP	Add to CRA 7
P70 03912 0018	FISHBURG RD	PP	Add to CRA 7
P70 03912 0089	5425 FISHBURG RD	PP	Add to CRA 7
P70 03912 0131	6251 MIAMI VALLEY WAY	PM	Add to CRA 7
P70 03912 0139	MIAMI VALLEY WAY	PM	Add to CRA 7
P70 03912 0140	MIAMI VALLEY WAY	PM	Add to CRA 7
P70 03912 0138	MIAMI VALLEY WAY	PM	Add to CRA 7
P70 00205 0012	5805 FISHBURG RD	R-1	Add to CRA 7
P70 02020 0004	5801 FISHBURG RD	PC	Add to CRA 7
P70 00205 0013	5861 FISHBURG RD	R-1	Add to CRA 7
P70 00205 0014	5875 FISHBURG RD	R-1	Add to CRA 7
P70 01808 0003	5101 BELLE RIDGE DR	PR	Add to CRA 7
P70 01808 0029	5281 BELLEFONTAINE RD	PC	Add to CRA 7
P70 01808 0022	BELLEFONTAINE RD	B-1	Add to CRA 7
P70 01808 0096	5188 BRANDT PIKE	B-1	Add to CRA 7
P70 01212 0009	4962 LEEPER ST	PR	Add to CRA 7
P70 01212 0002	4977 LEEPER ST	PR	Add to CRA 7
P70 01212 0010	4976 LEEPER ST	PR	Add to CRA 7
P70 01212 0005	4921 LEEPER ST	PR	Add to CRA 7
P70 01212 0001	4991 LEEPER ST	PR	Add to CRA 7
P70 01212 0006	4920 LEEPER ST	PR	Add to CRA 7
P70 01212 0004	4949 LEEPER ST	PR	Add to CRA 7
P70 01212 0007	4934 LEEPER ST	PR	Add to CRA 7
P70 01212 0008	4948 LEEPER ST	PR	Add to CRA 7
P70 01212 0003	4963 LEEPER ST	PR	Add to CRA 7
P70 03911 0020	5282 BELLEFONTAINE RD	PP	Add to CRA 7
P70 02107 0046	BRENTWOOD DR	PM	Add to CRA 7
P70 02107 0045	BRENTWOOD DR	PM	Add to CRA 7
P70 02113 0028	HEATHER WAY	PM	Add to CRA 7
P70 02107 0044	BELLEFONTAINE RD	PM	Add to CRA 7
P70 03911 0025	BELLEFONTAINE RD	B-1	Add to CRA 7
P70 02107 0043	BELLEFONTAINE RD	PM	Add to CRA 7
P70 03911 0023	5048 BELLEFONTAINE RD	B-1	Add to CRA 7
P70 03912 0079	5363 TILBURY RD	PP	Add to CRA 7
P70 03912 0078	5363 TILBURY RD	PP	Add to CRA 7
P70 03910 0055	8625 BRANDT PIKE	PM	CRA 5 to CRA 7
P70 03910 0056	8625 BRANDT PIKE	PM	CRA 5 to CRA 7
P70 03910 0061	7251 SHULL RD	PM	CRA 5 to CRA 7



- Existing CRA 7
- Proposed CRA 7 Areas
- Proposed CRA 5 to CRA 7

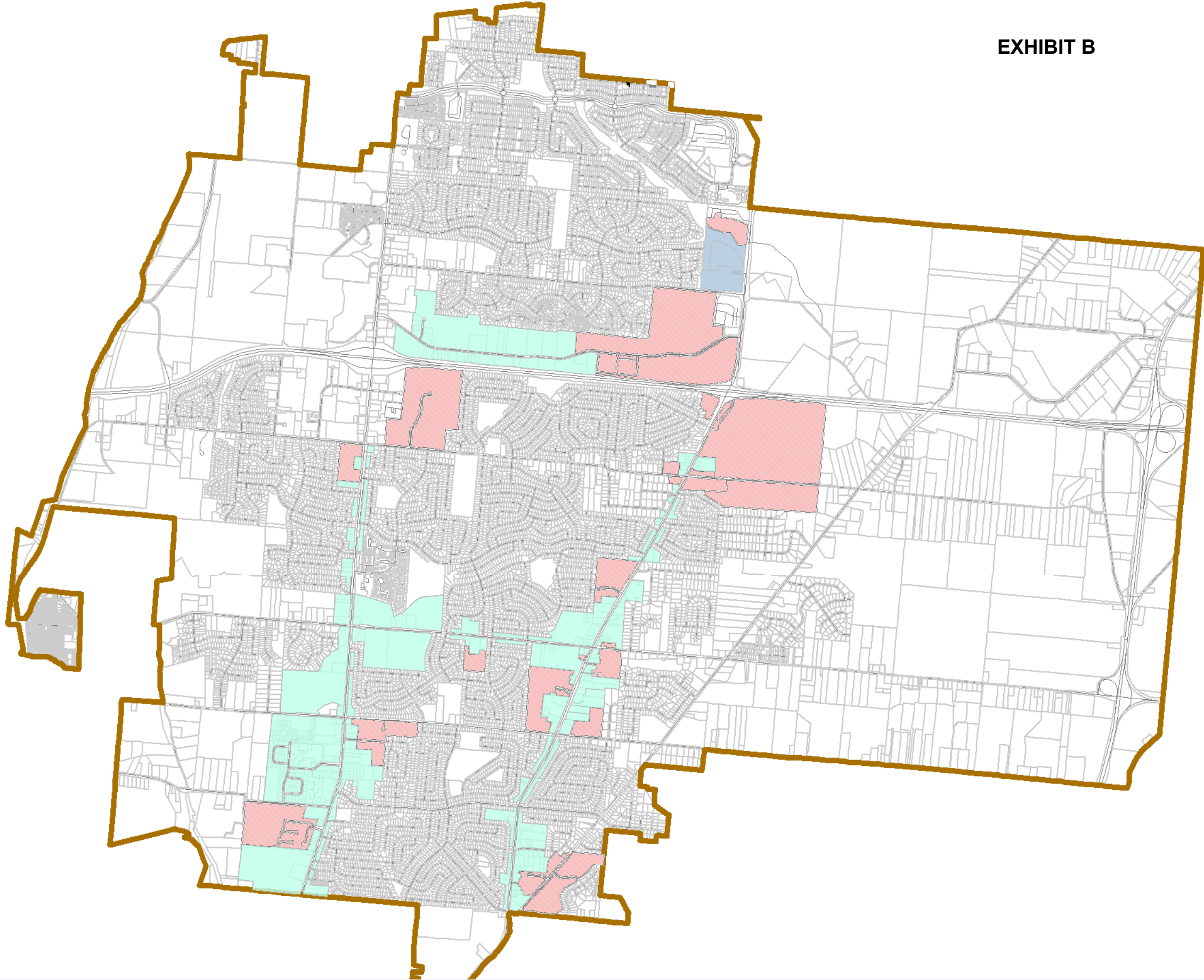

AI-8864

New Business J.
City Manager

City Council Special Meeting

Meeting Date: 12/15/2022

Moral Obligation Claim - Police Division

Submitted By: Jim Bell

Department: Finance

Division: Accounting

Council Committee Review?: Council Work Session

Date(s) of Committee Review: 12/06/2022

Audio-Visual Needs: None

Emergency Legislation?: No

**Motion/Ordinance/
Resolution No.:**

Agenda Item Description or Legislation Title

A Resolution Authorizing A Moral Claim For Tire Damage.
(first reading)

Purpose and Background

The Huber Heights Police Division was assisting Riverside Police Department, who was engaged in a pursuit of a stolen vehicle north on State Route 4, into the City's jurisdiction. A Huber Heights officer set up, with stop sticks, on State Route 4 at Chambersburg Road. The Huber Heights officer observed what he thought to be the suspect vehicle, approaching in the left lane. The Huber Heights officer pulled his stop sticks onto the roadway flattening three of the four tires on the truck. As the vehicle passed by, the Huber Heights officer realized the vehicle he spiked was not the suspect vehicle. The Huber Heights officer made contact with the driver/owner of the truck and took photographs of the damaged tires. The truck was identified as a 1998 Chevrolet Silverado.

City Staff request City Council approval of a moral obligation to reimburse the owner of the truck the cost for replacement of all four tires, since all four tires will need to be replaced.

The replacement cost for the tires has been quoted at \$1,027.66. A quote was received from Dayton Tire Sales, 3091 South Dixie Drive, Dayton, Ohio.

Fiscal Impact

Source of Funds: Police Fund

Cost: \$1,027.66

Recurring Cost? (Yes/No): No

Funds Available in Current Budget? (Yes/No): Yes

Financial Implications:

Attachments

Resolution

CITY OF HUBER HEIGHTS
STATE OF OHIO

RESOLUTION NO. 2022-R-

AUTHORIZING A MORAL CLAIM FOR TIRE DAMAGE.

WHEREAS, Huber Heights Police Division was assisting the Riverside Police Department, who was engaged in a pursuit of a stolen vehicle north on State Route 4 into Huber Heights; and

WHEREAS, a Huber Heights officer set up with stop sticks on State Route 4 at Chambersburg Road and observed what he thought to be the suspect vehicle approaching in the left lane; and

WHEREAS, the Huber Heights officer pulled his stop sticks onto the roadway flattening three of the four tires on the truck, but as the vehicle passed by it was realized the vehicle was not the suspect vehicle; and

WHEREAS, the Huber Heights officer made contact with the driver/owner of the truck, a 1998 Chevrolet Silverado, and took photographs of the damaged tires.

NOW, THEREFORE, BE IT RESOLVED by the City Council of Huber Heights, Ohio that:

Section 1. The City Manager is hereby authorized to make payment of \$1,027.66 to the driver/owner of the truck as identified by Huber Heights Police Division to cover the cost of replacement of all four tires in exchange for a release by the driver/owner.

Section 2. It is hereby found and determined that all formal actions of this Council concerning and relating to the passage of this Resolution were adopted in an open meeting of this Council and that all deliberations of this Council and of any of its Committees that resulted in such formal action were in meetings open to the public and in compliance with all legal requirements including Section 121.22 of the Ohio Revised Code.

Section 3. This Resolution shall go into effect upon its passage as provided by law and the Charter of the City of Huber Heights.

Passed by Council on the _____ day of _____, 2022;
_____ Yeas; _____ Nays.

Effective Date:

AUTHENTICATION:

Clerk of Council

Mayor

Date

Date

AI-8863

**New Business K.
Human Resources**

City Council Special Meeting

Meeting Date: 12/15/2022

City Staffing Levels/Table of Organization

Submitted By: Katie Knisley

Department: Human Resources

Council Committee Review?: Council Work Session
Date(s) of Committee Review: 11/22/2022; 12/06/2022

Audio-Visual Needs: None
Emergency Legislation?: No

**Motion/Ordinance/
Resolution No.:**

Agenda Item Description or Legislation Title

A Resolution Amending And/Or Establishing The City Of Huber Heights Organizational Chart And Authorizing The New Personnel Staffing Levels As Detailed Below.
(first reading)

Purpose and Background

This agenda item is for approval of legislation regarding the personnel staffing levels for all department/divisions within the City of Huber Heights to include amendments to those staffing levels and the Table Of Organization.

Fiscal Impact

Source of Funds: N/A

Cost: N/A

Recurring Cost? (Yes/No): N/A

Funds Available in Current Budget? (Yes/No): N/A

Financial Implications:

Attachments

Resolution

Table of Organization

CITY OF HUBER HEIGHTS
STATE OF OHIO

RESOLUTION NO. 2022-R-

AMENDING AND/OR ESTABLISHING THE CITY OF HUBER HEIGHTS ORGANIZATIONAL CHART AND AUTHORIZING THE NEW PERSONNEL STAFFING LEVELS AS DETAILED BELOW.

WHEREAS, the citizens of Huber Heights require the efficient and effective delivery of municipal services.

NOW, THEREFORE, BE IT RESOLVED by the City Council of Huber Heights, Ohio that:

Section 1. The attached organizational chart, personnel staffing levels, and position control numbers as established hereafter is hereby adopted and effective December 18, 2022.

Section 2. The authorized personnel staffing levels for the Clerk of Council are as follows.

<u>City Council</u>	<u>No.</u>	<u>Position Control No.</u>	<u>Pay Grade</u>
Clerk of Council	1	504-101-2-2-01-F	50
Deputy Clerk of Council	1	504-202-1-2-01-F	25
Public Records Technician	1	504-213-1-2-01-P/H	20

Section 3. The authorized personnel staffing levels for the City Manager's Office are as follows:

<u>City Manager's Office</u>	<u>No.</u>	<u>Position Control No.</u>	<u>Pay Grade</u>
City Manager	1	505-100-2-2-01-F	per contract
Assistant City Manager/Director of Public Services	1	505-117-2-2-01-F	75
Assistant to City Manager	1	505-618-2-2-01-F	40
Administrative Assistant III	1	505-209-2-2-01-F	25
Community Engagement Specialist	1	505-615-2-1-01-F	40

Section 4. The authorized personnel staffing levels for the Department of Public Safety are as follows:

<u>Department of Public Safety</u>	<u>No.</u>	<u>Position Control No.</u>	<u>Pay Grade</u>
Director of Public Safety	1	505-116-2-2-01-F	75

Division of Fire

Fire Chief	1	102-401-2-2-01-F	70
Medical Director/Wellness Coordinator	1	102-406-2-2-01-F	60
Battalion Chief	4	102-403-1-1-01-- 04F	PS
Captain	2	102-402-1-1-01—02F	PS
Fire Lieutenant	10	102-404-1-1-01--10-F	Contract
Firefighter/Paramedic	42	102-405-1-1-01—42-F	Contract
Administrative Assistant III	2	102-200-1-2-01--02-F	25
Administrative Assistant I	1	102-200-1-2-01-P/H	10
Fire Inspector	1	102-501-1-2-01-F	30
Fire Inspector	3	102-501-1-2-01- 03-P/H	30
Fire-Prevention Manager/Plans Review	1	102-502-1-2-01-P/H	50
Fire Fleet/Facility Mgt. Clerk	1	102-503-1-2-01-P/H	10
Auxiliary \$1.00 per year	30	102-411-3-0-01--30-V	V
Chaplains – Fire	2	102-601-3-0-01--02-V	V
Medical Advisor	1	102-604-3-0-01-V	V

Division of Police

Police Chief	1	101-406-2-2-01-F	70
--------------	---	------------------	----

Police Lieutenant	3	101-408-1-1-01--03-F	Contract
Police Sergeant	8	101-409-1-1-01--08-F	Contract
Police Officer	43	101-410-1-1-01--43-F	Contract
Administrative Assistant III	1	101-200-1-2-01-F	25
Administrative Assistant II	1	101-213-1-1-01-F	20
Police Accreditation Technician	1	101-515-1-1-01-F	30
Police Records Clerks	2	101-204-1-1-01--02-F	Contract
Police Evidence/Fleet Mgt. Clerk	2	101-205-1-2-02-P/H	20
Communications/Records Manager	1	101-611-2-1-01-F	45
Communications/Records Supervisor	1	101-613-1-1-01-F	35
Communications Officer	14	111-502-1-1-01-14-F	Contract
Chaplain – Police	3	101-601-3-0-01—03-V	V

Division of Code Enforcement

Code Enforcement Manager	1	310-621-2-1-01-F	45
Code Enforcement Officer II	1	310-513-1-1-01-01-F	35
Code Enforcement Officer I	4	310-513-1-2-01-04-P/H	20
Seasonal Laborer	2	310-305-1-2-01-02-S	S

Section 5. The authorized personnel staffing levels for the Department of Information Technology are as follows:

<u>Department of Information Technology</u>		<u>Position Control No.</u>	<u>Pay Grade</u>
Information Technology Director	1	509-105-2-2-01-F	60
Information Technology Systems Analyst	2	509-609-1-2-02-F	45
Information Technology Systems Analyst	1	509-609-1-2-01-P/H	45
GIS Technician	1	509-510-1-1-01-F	35

Section 6. The authorized personnel staffing levels for the Department of Finance are as follows:

<u>Department of Finance</u>	<u>No.</u>	<u>Position Control No.</u>	<u>Pay Grade</u>
Director of Finance	1	506-102-2-2-01-F	65
<u>Division of Accounting</u>			
Deputy Director of Finance	1	506-602-2-2-01-F	50
Accounting Generalist	2	506-603-2-2-02-F	40
Accounts Payable Technician	1	506-504-1-1-01-F	25
Payroll Technician	1	506-505-1-1-01-F	30
Account Technician	1	506-206-1-1-01 F	25
<u>Division of Taxation</u>			
Tax Administrator	1	507-104-2-2-01-F	50
Assistant Tax Administrator	1	507-612-2-2-01-F	45
Tax Analyst	2	507-506-1-1-01--02-F	30
Tax Technician	6	507-507-1-1-01 -06-F	20
Administrative Assistant I	3	507-212-1-2-01- 03P/H	10

Section 7. The authorized personnel staffing levels for the Department of Public Services are as follows:

<u>Department of Public Services</u>	<u>No.</u>	<u>Position Control No.</u>	<u>Pay Grade</u>
Director of Public Services	1	505-114-2-2-01-F	75
<u>Division of Engineering</u>			
City Engineer	1	320-106-2-2-01-F	65
Assistant City Engineer	1	320-119-2-2-01-F	55
Civil Engineer	1	320-605-2-2-01-01-F	50
Engineering Technician	2	320-509-1-1- 02-F	35
Administrative Assistant III	1	320-200-1-2-01-F	25

Division of Public Works

Public Works Manager	1	401-108-2-2-01-F	60
Public Works Supervisor	2	401-109-1-1-02-F	50
Parks Technician	1	401-618-1-1-01-F	40
Public Works Crew Leader	2	401-302-1-1-02-F	Contract
Vehicle & Equipment Mechanic	3	401-300-1-1-03-F	Contract
Maintenance Technician	20	401-301-1-1-20-F	Contract
Administrative Assistant III	1	401-200-1-2-01-F	25
Custodian	1	401-305-1-2-01-F	10
Custodian	1	401-305-1-2-01-P/H	10

Section 8. The authorized personnel staffing levels for the Department of Economic Development are as follows:

<u>Department of Economic Development</u>	<u>No.</u>	<u>Position Control No.</u>	<u>Pay Grade</u>
Economic Development Director	1	305-111-2-2-01-F	60
Economic Development Coordinator	1	305-614-2-1-01-F	40

Section 9. The authorized personnel staffing levels for the Department of Planning and Zoning are as follows:

<u>Department of Planning & Community Dev.</u>	<u>No.</u>	<u>Position Control No.</u>	<u>Pay Grade</u>
Planning & Community Dev. Director	1	310-121-2-2-01-F	60
City Planner	1	310-118-2-2-01-F	55
Administrative Assistant III	1	310-200-1-2-01-F	25
Administrative Assistant I	1	310-207-1-1-01-F	10
Administrative Assistant I	1	310-207-1-2-01-P/H	10

Section 10. The authorized personnel staffing levels for the Department of Human Resources are as follows:

<u>Department of Human Resources</u>	<u>No.</u>	<u>Position Control No.</u>	<u>Pay Grade</u>
Human Resources Director	1	510-120-2-2-01-F	60
Human Resources Specialist	1	510-617-1-1-01-F	40
Human Resources Assistant	1	510-514-1-2-01-P/H	30

Section 11. The authorized personnel staffing levels for the Department of Parks and Recreation Facilities are as follows:

<u>Department of Parks and Recreation Facilities</u>	<u>No.</u>	<u>Position Control No.</u>	<u>Pay Grade</u>
Senior Center Program Coordinator	1	215-110-2 -2 -01-P/H	25
Seasonal Laborer – Music Center	125	219-306-1-2-01--125-S	S
Seasonal Laborer	4	216-303-1-2-01--04-S	S

Section 12. Council further ratifies and affirms any and all previous legislation of Council that established, abolished or altered the functions and structures of any administrative department.

Section 13. It is hereby found and determined that all formal actions of this Council concerning and relating to the passage of this Resolution were adopted in an open meeting of this Council and that all deliberations of this Council and of any of its Committees that resulted in such formal action were in meetings open to the public and in compliance with all legal requirements including Section 121.22 of the Ohio Revised Code.

Section 14. This Resolution shall go into effect upon its passage as provided by law and the Charter of the City of Huber Heights.

Section 15. Position Control Number Explanation:

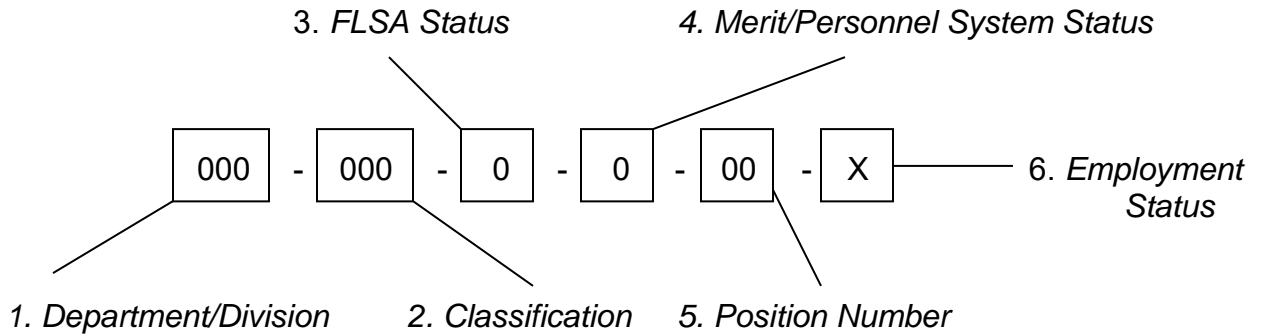

1. Department/Division: Number represents Fund Number in General Ledger:

- | | | | |
|------------------------|-----------------------|------------------|-----------|
| 101-Police | 305-Economic Dev. | 401-Public Works | 507-Tax |
| 102-Fire | 310 Planning & Zoning | 505-City Mgr. | 509-I. T. |
| 215-Senior Center | 320-Engineering | 506-Accounting | 510-H.R |
| 219 Parks & Recreation | | | |

2. Classification: Number for classification or rank to which position is assigned, divided into defined series as shown below:

- | | | |
|--------------------|------------------|------------------|
| 100-Administrative | 300-Labor | 500-Technical |
| 200-Clerical | 400-Sworn Safety | 600-Professional |

3. FLSA Status:

- 01-Non-exempt from minimum wage/overtime rules of FLSA (hourly)
- 02-Exempt from minimum wage/overtime rules of FLSA (salaried)
- 03-Unpaid Volunteer

4. Merit & Personnel System Status:

- 01-Position is in Non-exempt service of city per Section 8.02 of Charter
- 02-Position is in Exempt service of city per Section 8.02 of Charter

5. Position Number:

Unique two-digit number for each employment position authorized by this Resolution.

6. Employment Status:

- F-Full-time Position
- P-Part-time Position
- H-Hourly Position
- T-Temporary (created for specific time)
- S-Seasonal Position
- V-Volunteer Position

Passed by Council on the _____ day of _____, 2022;
 _____ Yeas; _____ Nays.

Effective Date:

AUTHENTICATION:

 Clerk of Council

 Mayor

 Date

 Date

AI-8817

**New Business L.
Economic Development**

City Council Special Meeting

Meeting Date: 12/15/2022

Real Estate Exchange - Wright Way Ohio, LLC

Submitted By: Bryan Chodkowski

Department: Economic Development

Council Committee Review?: Council Work Session
Date(s) of Committee Review: 12/06/2022

Audio-Visual Needs: None
Emergency Legislation?:

**Motion/Ordinance/
Resolution No.:**

Agenda Item Description or Legislation Title

A Resolution Authorizing The City Manager To Enter A Real Estate Exchange Agreement With Wright Way Ohio, LLC.
(first reading)

Purpose and Background

Wright Way Ohio, LLC owns approximately 33 acres of land abutting I-70 behind Cedar Hill Furniture store and would like to exchange this acreage for the City's 67 acres behind Camping World on Old Troy Pike. Wright Way desires this land exchange in furtherance of an interest to develop a Yogi Bear/Jellystone-type campground.

Fiscal Impact

Source of Funds: N/A

Cost: N/A

Recurring Cost? (Yes/No): N/A

Funds Available in Current Budget? (Yes/No): N/A

Financial Implications:

Attachments

Resolution

Exhibit A

Exhibit A - Exhibit A

Exhibit A - Exhibit B

CITY OF HUBER HEIGHTS
STATE OF OHIO

RESOLUTION NO. 2022-R-

AUTHORIZING THE CITY MANAGER TO ENTER A REAL ESTATE EXCHANGE AGREEMENT WITH WRIGHT WAY OHIO, LLC.

WHEREAS, Wright Way Ohio, LLC (“Wright Way”) is the owner of certain parcels of property addressed as 7880 Cedar Hill Drive totaling approximately 33.64 acres; and

WHEREAS, the City of Huber Heights (“City”) is the owner of a certain parcel of property addressed as 8101 Old Troy Pike totaling approximately 67.39 acres; and

WHEREAS, Wright Way wishes to develop a campground within the City and desires to be in immediate proximity to the retailer Camping World; and

WHEREAS, the City desires to control real estate in immediate proximity to Interstate 70.

NOW, THEREFORE, BE IT RESOLVED by the City Council of Huber Heights, Ohio that:

Section 1. The City Manager is hereby authorized to execute a real estate exchange agreement with Wright Way Ohio, LLC, a copy of which is attached hereto as Exhibit A as if incorporated herein.

Section 2. It is hereby found and determined that all formal actions of this Council concerning and relating to the passage of this Resolution were adopted in an open meeting of this Council and that all deliberations of this Council and of any of its Committees that resulted in such formal action were in meetings open to the public and in compliance with all legal requirements including Section 121.22 of the Ohio Revised Code.

Section 3. This Resolution shall go into effect upon its passage as provided by law and the Charter of the City of Huber Heights.

Passed by Council on the _____ day of _____, 2022;
_____ Yeas; _____ Nays.

Effective Date:

AUTHENTICATION:

Clerk of Council

Mayor

Date

Date

REAL ESTATE EXCHANGE AGREEMENT

This Real Estate Exchange Agreement (“Agreement”) is made and entered into as of the date signed by the last party to execute this Agreement (the ‘Effective Date’), by and between **CITY OF HUBER HEIGHTS**, an Ohio municipal corporation (“City”) and **WRIGHT WAY OHIO, LLC** (“Wright Way”).

WHEREAS, Wright Way is the owner of certain properties at 7880 Cedar Hill Dr. with Parcel Numbers: P70 03909 0028 and P70 03909 0027 (the “Wright Way Parcels”) being approximately 33.64 total acres which is located generally near the South East quadrant of Brandt Pike and I 70 which is legally described on Exhibit A attached hereto and incorporated herein by reference; and

WHEREAS, City is the owner of certain property at 8101 Old Troy Pike, Parcel Number: P70 02025 0012 the (“City Parcel”) being approximately 67.39 acres which is located generally behind the existing Camping World facility which is legally described on Exhibit B attached hereto and incorporated herein by reference; and

WHEREAS, each party has an interest in acquiring the other parties’ parcel(s) and are looking via a real estate exchange pursuant to the terms and conditions of this Agreement; and

WHEREAS, Wright Way would use the City Parcel as a campground facility; and

WHEREAS, City would use/or transfer the Wright Way Parcels for a use other than as a campground facility;

WHEREAS, City Council has authorized the execution of this Agreement and transfer of land in Resolution _____ passed _____.

NOW, THEREFORE, in consideration of the mutual covenants and agreements herein contained and for other good and valuable consideration, the receipt and adequacy of which are hereby acknowledged, the City and Wright Way agree as follows.

1. Conveyance of City Parcel. Subject to the following and the other terms provisions, covenants and conditions set forth herein, the City hereby agrees to convey the City Parcel to Wright Way, and Wright Way hereby agrees to acquire the City Parcel from the City:

(a) Consideration for the City Parcel. As consideration for the City’s conveyance of the City Parcel to Wright Way, Wright Way shall transfer the Wright Way Parcels to the City in accordance with this Agreement and shall fully and faithfully perform all of its other duties and obligations on its part to be performed under this Agreement.

(b) Title to City Parcel. At the Closing, (as defined herein) the City shall transfer to Wright

Way, by limited warranty deed, fee simple title to the City Parcel, subject to (i) legal highways, (ii) the liens of real estate taxes and assessments which are not yet due and payable; and (iii) covenants, restrictions, conditions and easements of record.

(c) Inspection Period; Contingencies for City Parcel. Within ten (10) days after the Effective Date, City shall deliver or cause to be delivered to the Wright Way any and all documentation and materials not previously delivered to the Wright Way relating to the condition of the City Parcel as may be in the City's possession or under its control.

(d) Inspections. Wright Way shall have the period from the Effective Date until that date which is forty-five (45) days after the Effective Date (the "Inspection Period") to conduct any and all inspections, investigations and verifications regarding the property to be acquired as it deems necessary, including title searches, in its sole discretion. If Wright Way desires to obtain a title commitment and/or title insurance it shall do so at its sole cost and expense.

(e) Access. City hereby gives to Wright Way and its agents, employees, contractors and representatives a continual right of access to the City Parcel during the term of this Agreement at reasonable times for the purposes of conducting tests, inspections, and/or studies to formulate plans and determine the suitability of the property for such Wright Way's intended use of the Property. Wright Way shall defend, indemnify and save harmless the City from any and all claims, losses, damages and expenses arising from the entry onto the City Parcel by the Wright Way, or its agents, employees, contractors and representatives.

2. Conveyance of Wright Way Parcels. Subject to the following and the other terms provisions, covenants and conditions set forth herein, Wright Way hereby agrees to convey the Wright Way Parcels to the City, and the City hereby agrees to acquire the Wright Way Parcels from Wright Way.

(a) Consideration for the Wright Way Parcels. As consideration for the Wright Way's conveyance of the Wright Way Parcels to the City, Wright Way shall transfer the Wright Way Parcels to the City in accordance with this Agreement and shall fully and faithfully perform all of its other duties and obligations on its part to be performed under this Agreement.

(b) Title to Wright Way Parcels. At the Wright Way Parcels Closing, (as defined herein) Wright Way shall transfer to the City, by limited warranty deed, fee simple title to the Wright Way Parcels, subject to (i) legal highways, (ii) the liens of real estate taxes and assessments which are not yet due and payable; and (iii) covenants, restrictions, conditions and easements of record.

(c) Inspection Period; Contingencies for City Parcel. Within ten (10) days after the Effective Date, Wright Way shall deliver or cause to be delivered to the City any and all documentation and materials not previously delivered to the City relating to the condition of the Wright Way Parcels as may be in Wright Ways' possession or under its control.

(d) Inspections. The City shall have the period from the Effective Date until that date which is forty-five (45) days after the Effective Date (the “Inspection Period”) to conduct any and all inspections, investigations and verifications regarding the property to be acquired as it deems necessary, in its sole discretion. Prior to the end of the Inspection Period the City shall obtain a title commitment from a title company of City’s choosing at City’s sole cost and expense.

(e) Access. Wright Way hereby gives to City and its agents, employees, contractors and representatives a continual right of access to the Wright Way Parcels during the term of this Agreement at reasonable times for the purposes of conducting tests, inspections, and/or studies to formulate plans and determine the suitability of the property for such the City’s intended use of the Property.

3. Termination. Each Party shall have the right to terminate this Agreement for any reason or for no reason by delivering written notice thereof to the other Party on or before the expiration of the Inspection Period, and upon any such termination, neither Party shall have any further liabilities, rights, or obligations hereunder except those which expressly survive the termination of this Agreement. If a Party fails to deliver a written notice of termination to the other Party on or before the expiration of the Inspection Period, such Party shall be deemed to have elected not to terminate this Agreement.

4. Closing. Provided that this Agreement has not been terminated and all conditions precedent to the closing of the City Parcel and Wright Way Parcels set forth herein have been satisfied or waived, the Closing shall take place within 30 days after the end of the Inspection Period in Montgomery County Ohio.

5. Zoning/Development for City Parcel.

a. The City Parcel is currently zoned PC Planned Commercial. Wright Way will submit to the City for approval a preliminary plan and detailed development plan. Wright Way Ohio intends to make the City Parcel a first-class campground facility that can be utilized by the citizens of Huber Heights as a green space amenity and to promote the businesses surrounding the campground for families traveling to events both in and around the community. The parties agree that the plans attached hereto as Exhibit C will be considered the preliminary sketch plan for the City Parcel. The City shall cooperate with Wright Way in obtaining approval of zoning plans, prior to the end of the Inspection Period, however, such cooperation by the City under this Agreement shall not be construed or interpreted as a guaranty, waiver or avoidance of any City or other governmental process or approval ordinarily required with respect to the ownership, possession, zoning, development or construction on the City Parcel.

b. Other than structures generally provided with a campground, the City shall provide in the deed to Wright Way that the City Parcel shall remain perpetually free of commercial and residential buildings and structures. Said Restrictive Covenant

shall run with the land. Such Restrictive Covenant shall only apply to commercial and residential buildings and structures or other such amenities generally associated with a campground, all of which may be located on the land. The intent of this Restrictive Covenant is to protect the open area.

- c. With respect to the development of the City Parcel by Wright Way, city will cooperate with approval for signage locations for directing campers to the facility at appropriate locations within the city as permitted under the City sign ordinances. To the extent permitted by applicable law, City will provide a 50% tax abatement for the first 5 years to offset construction costs and initial advertisement costs.

6. Proration of Real Estate Taxes; Closing Costs. Each party will pay with respect to each parties own parcel: (a) all real estate taxes and assessments, including any penalties and interest, which became due and payable prior to the closing, (b) a pro rata share, calculated as of the closing date in the manner set forth below, of the taxes and assessments becoming due and payable after the closing, and (c) the amount of any agricultural tax savings accrued as of the closing date which would be subject to recoupment if the Property were converted to a non-agricultural use (if any). The tax proration shall be made in accordance the "long proration" method in which the share is based upon the taxes and assessments which are a lien for the year of closing. All prorations shall be based on the most recent available tax rates, assessments and valuations. Except as otherwise expressly stated in this Agreement, each party will pay its own costs related to inspections, any title insurance search commitment and policy premium, recording fee for recording of the deed to the parcel it is obtaining. The parties shall equally share the customary closing costs charged by the title company that handles the closing (if any).

7. Additional Encumbrances. Each Party shall not further encumber, or permit to be encumbered, its respective property for the period from the Effective Date through the closing date for such Property without the other Party's prior written approval, which may be withheld in such other Party's sole and absolute discretion.

8. Representations and Warranties. Each Party represents and warrants as follows:

(a) Said party owns good and marketable fee simple title to its respective parcel and, by and through the undersigned has the authority to execute this Agreement and to transfer good and marketable fee simple title to its respective parcel according to this Agreement and free and clear of any leases, occupants and/or tenants.

(b) There is no action, suit, proceeding, attachments, assignments for the benefit of creditors or voluntary or involuntary proceedings in bankruptcy, or investigation pending or threatened before any agency, court of governmental authority which relates to a party's parcel (including, without limitation, any condemnation proceeding), nor does a party know or have reasonable grounds to know of any basis for any such action, suit, proceeding or investigation.

(c) To the best of the party's knowledge and belief, no portion of its respective parcel being conveyed is located within a defined wetland.

(d) To the best of the party's knowledge and belief, no Hazardous Substance has been generated, treated, stored, disposed of, released, generated or otherwise deposited in or located on said party's parcel. And, neither party, nor, to the best of said party's knowledge and belief, any of its respective predecessors-in-title have violated or received any notice of violation of any law relating to the health, safety or environment. The warranties and representations as set forth in this Section, shall survive the Closings.

9. Entire Agreement. This Agreement and its exhibits constitute the entire agreement of the parties and no other statement or representation shall be considered a part of this Agreement, or binding upon the parties, unless the same shall be contained herein. Any reference to a period of days shall be deemed to be calendar days, unless otherwise expressly stated.

10. Notices. Any notice, request, demand, instruction or communication hereunder shall be in writing and shall be deemed to have been duly given: (i) three (3) business days after deposit in registered or certified U.S. mail, postage fully prepaid, (ii) one (1) day after deposit with a recognized overnight delivery service such as Federal Express, or (iii) immediately upon facsimile transmittal, addressed as follows:

as to the City:

City of Huber Heights, Ohio
6131 Taylorsville Road
Huber Heights, Ohio 45424
Attention: City Manager
Telephone: (937) 233-1423
Facsimile: (937) 233-1272

With a duplicate to:

City of Huber Heights-Law Department
2700 Stratacache Tower
Pickrel Schaeffer & Ebeling
Dayton, Ohio 45423
Attention: Law Director
Telephone: (937) 223-1130

As to Wright Way:

Wright Way Ohio, LLC
P.O. Box 832
Fairborn OH 45324

With a duplicate to:

The addresses for the purpose of this paragraph may be changed by giving notice as provided herein. Notice shall also be deemed to have been given upon receipt of actual knowledge by any means of the information contained in said notice.

11. Time. Time is of the essence of this Agreement. Notwithstanding any provision in this Agreement to the contrary, if the period of time for the giving of any notice or approval, or for the taking of any action, should expire on a day which is not a “business day”, then the time for giving such notice or approval, or for taking such action, will be extended to the next succeeding business day.

12. Brokers. The parties hereby warrant to the other that no real estate agents have been hired or consulted for this Property.

13. Governing Law and Interpretation. The validity, meaning and effect of this Agreement shall be determined in accordance with the laws of the State of Ohio.

14. Counterparts. This Agreement may be executed in two or more counterparts, each of which shall be deemed an original, but all of which together shall constitute one and the same instrument.

15. Captions. The captions in this Agreement are inserted for convenience of reference only and in no way define, describe or limit the scope or intent of this Agreement of any of the provisions thereof.

16. Binding Effect. This Agreement shall be binding upon and shall inure to the benefit of the parties hereto and their respective successors and assigns.

17. Waiver. The failure by any party to exercise any of its rights hereunder or to enforce any of the terms or conditions of this Agreement on any occasion shall not constitute or be deemed a waiver of that party's rights thereafter to exercise any rights hereunder or to enforce each and every term and condition of this Agreement.

18. Cooperation. The Parties agree to execute and deliver such additional documents and to perform such additional acts as may become reasonably necessary to effectuate the intent of this Agreement.

19. Signatures. The parties acknowledge that signatures on this Agreement of the parties may be delivered by facsimile in lieu of an original signature, and the parties agree to treat such signatures as original signatures and shall be bound thereby.

20. Assignment: Neither party may assign its rights under this Agreement without the others consent.

21. No Third Party Beneficiaries. None of the terms, conditions or covenants in this Agreement shall give or allow any claim, benefit, or right of action by any third person not a party hereto. Any person other than the City or the Wright Way receiving services or benefits under this Agreement shall be only an incidental beneficiary.

22. Definitions For purposes of this Agreement, “Environmental Laws” means and includes the Comprehensive Environmental Response and Liability Act (“CERLA” or the Federal Superfund Act) as amended by the Superfund Amendments and Reauthorization Act of 1986 (“SARA”) 42 U.S.C. Sections 9601-9675; the Federal Resource Conservation and Recovery Act of 1976 (“RCRA”); the Clean Water Act, 33 U.S.C., Section 1321, et seq.; the Clean Air Act. 42 U.S.C., Section 7401, et seq. all as the same may be from time to time amended and any other federal, state county, municipal, local or other statute, law, ordinance or regulation which may

relate to or deal with the environment or human health, safety or welfare, including, without limitation, all regulations promulgated by a regulatory body pursuant to any such statute, law or ordinance. "Hazardous Substances" shall mean and refer to the following: petroleum products and fractions thereof, asbestos, asbestos containing materials, urea formaldehyde, polychlorinated biphenyls, radioactive materials and all other dangerous, toxic or hazardous pollutants, contaminants, chemicals, materials, substances and wastes listed or identified in, or regulated by, any federal, state/commonwealth, county, municipal, local and other statutes, laws, ordinances and regulations which relate to or deal with human health or the environment, all as may be amended from time to time.

CITY OF HUBER HEIGHTS

an Ohio municipal corporation

Bryan Chodkowski
Interim City Manager

Date: _____ 2022

WRIGHT WAY OHIO, LLC

Date: _____ 2022



Land Exchange Agreement - Exhibit A



1 inch = 376 feet

Date: 11/22/2022





Sources: Esri, Airbus DS, USGS, NGA, NASA, CGIAR, N Robinson, NCEAS, NLS, OS, NMA, Geodatastyrelsen, Rijkswaterstaat, GSA, Geoland, FEMA, Intermap and the GIS user community



Land Exchange Agreement - Exhibit B



1 inch = 752 feet

Date: 11/22/2022

AI-8853

New Business M.
Finance

City Council Special Meeting

Meeting Date: 12/15/2022

Advances/Transfers - Finance Department

Submitted By: Jim Bell

Department: Finance **Division:** Accounting

Council Committee Review?: Council Work Session

Date(s) of Committee Review: 12/06/2022

Audio-Visual Needs: None **Emergency Legislation?:** Yes

**Motion/Ordinance/
Resolution No.:**

Agenda Item Description or Legislation Title

An Ordinance Authorizing A One-Time Transfer Of Monies From The General Fund To Document An Advance Previously Made To The Community Development Block Grant Fund And Declaring An Emergency.
(first reading)

Purpose and Background

An advance was made from the General Fund to the Community Development Block Grant (CDBG) Fund for a blighted property project. The advance for this project was \$16,999.41 in anticipation of the receipt of grant dollars which were never received. The Director of Finance recommends that the original advance of \$16,999.41 be now classified as a transfer from the General Fund to the CDBG Fund. This legislation, if approved, will make that correction so that those monies will not be expected to be returned to the General Fund. In order for this transaction to be reconciled by the end of 2022, the Director of Finance requests that the second reading of the legislation be waived and that this legislation be adopted as emergency legislation at the December 12, 2022 City Council Meeting.

Fiscal Impact

Source of Funds: N/A

Cost: N/A

Recurring Cost? (Yes/No): N/A

Funds Available in Current Budget? (Yes/No): N/A

Financial Implications:

Attachments

Ordinance

CITY OF HUBER HEIGHTS
STATE OF OHIO

ORDINANCE NO. 2022-O-

AUTHORIZING A ONE-TIME TRANSFER OF MONIES FROM THE GENERAL FUND TO DOCUMENT AN ADVANCE PREVIOUSLY MADE TO THE COMMUNITY DEVELOPMENT BLOCK GRANT FUND AND DECLARING AN EMERGENCY.

WHEREAS, the auditing firm of Plattenburg & Associates requires documentation of previously made advances to be authorized as transfers; and

WHEREAS, this Ordinance serves to satisfy the auditors' requirements.

NOW, THEREFORE, BE IT ORDAINED by the City Council of Huber Heights, Ohio that:

Section 1. The Director of Finance is authorized to document the previous advance listed below as a transfer as follows:

General Fund (101) to Community Development Block Grant Fund (222) - \$16,999.41

Section 2. It is hereby found and determined that all formal actions of this Council concerning and relating to the passage of this Ordinance were adopted in an open meeting of this Council and that all deliberations of this Council and of any of its Committees that resulted in such formal action were in meetings open to the public and in compliance with all legal requirements including Section 121.22 of the Ohio Revised Code.

Section 3. This Ordinance is declared to be an emergency measure necessary for the immediate preservation of the public peace, health, safety, or welfare of the inhabitants of the City, and for the further reason of the need to immediately provide for improved organizational structures in the City; therefore, this Ordinance shall take full force and effect immediately upon its adoption by Council.

Passed by Council on the _____ day of _____, 2022;
_____ Yeas; _____ Nays.

Effective Date:

AUTHENTICATION:

Clerk of Council

Mayor

Date

Date

AI-8866

New Business N.
Finance

City Council Special Meeting

Meeting Date: 12/15/2022

Supplemental Appropriations

Submitted By: Jim Bell

Department: Finance **Division:** Accounting

Council Committee Review?: Council Work Session

Date(s) of Committee Review: 12/06/2022

Audio-Visual Needs: None **Emergency Legislation?:** No

**Motion/Ordinance/
Resolution No.:**

Agenda Item Description or Legislation Title

An Ordinance Authorizing Advances And Transfers Between Various Funds Of The City Of Huber Heights, Ohio And Amending Ordinance No. 2021-O-2511 By Making Supplemental Appropriations For Expenses Of The City Of Huber Heights, Ohio For The Period Beginning January 1, 2022 And Ending December 31, 2022.
(first reading)

Purpose and Background

The supplemental appropriations are for the following purposes:

- \$56,461.40 transfer from FEMA Fund to Fire Fund for federal funds to be received in reimbursement of Fire overtime for deployment for Kentucky flooding and Hurricane Ian.
- \$1,000,000 return of advance back to the General Fund for the initial funding of the Veterans Memorial construction project, prior to receipt of the bond proceeds.
- \$116,000 to cover the differences in Aquatic Center revenues and expenses.
- \$50,000 reduction in operating expenses in the Parks Division.
- \$66,000 reduction in operating expenses of the Rose Music Center.
- \$50,000 for repair/replacement costs of traffic control box at intersection of SR202 and Longford.
- \$30,000 for purchase of land to build a City road.
- \$30,000 for purchase of land for economic development purposes.

Fiscal Impact

Source of Funds: Various Funds

Cost: \$80,000

Recurring Cost? (Yes/No): No

Funds Available in Current Budget? (Yes/No): Yes

Financial Implications:

The return of Advance from Capital Improvement Fund to General Fund is revenue that was received from a bond issuance. The transfer from the FEMA Fund to Fire Fund is for federal funds that are anticipated to be received in December. These two costs are net neutral for fiscal impact to the budget.

Attachments

Ordinance

CITY OF HUBER HEIGHTS
STATE OF OHIO

ORDINANCE NO. 2022-O-

AUTHORIZING ADVANCES AND TRANSFERS BETWEEN VARIOUS FUNDS OF THE CITY OF HUBER HEIGHTS, OHIO AND AMENDING ORDINANCE NO. 2021-O-2511 BY MAKING SUPPLEMENTAL APPROPRIATIONS FOR EXPENSES OF THE CITY OF HUBER HEIGHTS, OHIO FOR THE PERIOD BEGINNING JANUARY 1, 2022 AND ENDING DECEMBER 31, 2022.

WHEREAS, supplemental appropriations for expenses of the City of Huber Heights must be made for appropriations of funds for various 2022 operating and project funding.

NOW, THEREFORE, BE IT ORDAINED by the City Council of Huber Heights, Ohio that:

Section 1. Authorization is hereby given to advance and transfer certain monies up to amounts not exceeding those shown and for the purposes cited in Exhibit A, and such authorization applies to any and all such advances and transfers necessary and effected after January 1, 2022.

Section 2. Ordinance No. 2021-O-2511 is hereby amended as shown in Exhibit B of this Ordinance.

Section 3. It is hereby found and determined that all formal actions of this Council concerning and relating to the passage of this Ordinance were adopted in an open meeting of this Council and that all deliberations of this Council and of any of its Committees that resulted in such formal action were in meetings open to the public and in compliance with all legal requirements including Section 121.22 of the Ohio Revised Code.

Section 4. This Ordinance shall go into effect upon its passage as provided by law and the Charter of the City of Huber Heights.

Passed by Council on the _____ day of _____, 2022;
_____ Yeas; _____ Nays.

Effective Date:

AUTHENTICATION:

Clerk of Council

Mayor

Date

Date

EXHIBIT A

Transfer:

<u>Amount</u>	<u>Fund From</u>	<u>Fund To</u>	<u>Purpose</u>
\$56,461.40	251 FEMA	210 Fire	Reimburse Fire O.T. for Ky flooding and Hurricane Ian
\$30,000.00	203 Gas Tax	406 Cap Imp	Purchase land to construct new road

Advance:

<u>Amount</u>	<u>Fund From</u>	<u>Fund To</u>	<u>Purpose</u>
\$1,000,000.00	406 Capital Imp	101 General	Return advance for Veterans Memorial initial funding

EXHIBIT B

AMENDING ORDINANCE NO. 2021-O-2511 BY MAKING APPROPRIATIONS FOR EXPENSES OF THE CITY OF HUBER HEIGHTS, OHIO FOR THE PERIOD BEGINNING JANUARY 1, 2022 AND ENDING DECEMBER 31, 2022.

- 1) Section 3 of Ordinance No. 2021-O-2511 is hereby amended to reflect an increase in the appropriations of the 203 Gasoline Tax Fund, as follows:
 - a. Subsection c) Non-Departmental, Transfers of \$30,000.00.
- 2) Section 12 of Ordinance No. 2021-O-2511 is hereby amended to reflect changes in the appropriations of the 218 Parks & Recreation Fund, as follows:
 - a. Subsection b) Parks & Recreation, Operations and Capital decrease of \$50,000.00
 - b. Subsection c) Aquatic Center, Operations and Capital increase of \$116,000.00
 - c. Subsection d) Music Center, Operations and Capital decrease of \$66,000.00.
- 3) Section 15 of Ordinance No. 2021-O-2511 is hereby amended to reflect an increase in the appropriations of the 226 Local Street Operating Fund, as follows:
 - a. Subsection a) Streets, Operations and Capital of \$50,000.00
- 4) Section 30 of Ordinance No. 2021-O-2511 is hereby amended to reflect an increase in the appropriations of the 406 Capital Improvement Fund, as follows:
 - a. Subsection c) Capital, Operations and Capital of \$30,000.00.
 - b. Subsection d) Non-Departmental, Advances of \$1,000,000.00
- 5) Section 31 of Ordinance No. 2021-O-2511 is hereby amended to reflect changes in the appropriations of the 410 Transformative Economic Development Fund, as follows:
 - a. Subsection a) Economic Development, Operations and Capital increase of \$30,000.00.
 - b. Subsection b) Non-Departmental, Debt decrease of \$30,000.00
- 6) Section 50 of Ordinance No. 2021-O-2511 is hereby added to reflect an increase in the appropriations of the 251 FEMA Fund, as follows:
 - a. Subsection a) Non-Departmental, Transfers of \$56,461.40.

Gasoline Tax Fund	\$30,000.00
Parks & Recreation Fund	\$0.00
Local Street Operating Fund	\$50,000.00
Capital Improvements Fund	\$1,000,000.00
Transformative Econ. Dev. Fund	\$0.00
FEMA Fund	\$56,461.40

AI-8847

New Business O.
Police

City Council Special Meeting

Meeting Date: 12/15/2022

Equipment Purchase Agreement - Patterson Pope - Police Division

Submitted By: Maria Beisel

Department: Police **Division:** Police

Council Committee Review?: Council **Date(s) of Committee Review:** 12/06/2022
Work
Session

Audio-Visual Needs: None **Emergency Legislation?:** No

**Motion/Ordinance/
Resolution No.:**

Agenda Item Description or Legislation Title

A Resolution Authorizing The City Manager To Enter Into An Agreement With Patterson Pope To Purchase New Lockers And Benches For Both Locker Rooms In The Huber Heights Police Division And Waiving The Competitive Bidding And Request For Proposals Requirements.
(first reading)

Purpose and Background

The current lockers and benches are original to the Police Division building from 1992 and have rusted beyond repair. A cooperative purchasing contract is available for new Spacesaver Technology equipped lockers. Additionally, a local resident has offered a \$100,000 donation toward the cost of the project.

Fiscal Impact

Source of Funds: Police Fund/Donation

Cost: \$160,000

Recurring Cost? (Yes/No): No

Funds Available in Current Budget? (Yes/No): Yes

Financial Implications:

N/A

Attachments

State Bid

Electric Quote

Resolution



STATE OF OHIO EXTENSION & PRICE LIST UPDATE

CONTRACT:	800859 - Moveable Shelf Filing Systems
EFFECTIVE DATE:	7/1/2022 – 6/30/2024
SPACESAVER ASSIGNED NUMBER:	4122
PRODUCTS:	Spacesaver manufactured product (excludes ActivRAC Stainless Steel)
AC/END USER PRICE LIST:	Per Contract Price List available in Configura Surcharge line does not apply (incorporated in list price)
AC DISCOUNT	Standard Commercial (effective 10/25/2021)
END USER DISCOUNT:	Available via End User Quote in Configura refer to page 2 for discount table
AUTHORIZED USERS:	Available to all state agencies, state institutions of higher education and political subdivisions properly registered as members of the Cooperative Purchasing Program of the Department of Administration Services, as applicable.
COMPETITORS:	Aurora, Tab, Tenssco
FREIGHT CHARGES:	End User: Included in end user discount. Area Contractor: Arranges the carrier and pays freight bill
INSTALLATION:	Quoted per project
INVOICING & PURCHASE ORDER:	Purchase Order issued to & invoiced by the Area Contractor
WEBSITE:	Link to Contract Details

- ✓ Select the Ohio, State of option under the State/Local Government radio button in Configura. This will auto-fill the Spacesaver Assigned Contract Number (SSC# 4122) utilized for tracking sales. Contract compliance is crucial for remaining in good standing with our contract partners.
- ✓ End User Purchase Order is required with order submittal.



Proposal

Quote #: Q-51140-1
 Drawing Ver: 336236 1A
 Date: 9/14/2022
 Expires On: 12/13/2022

Patterson Pope

Remit To:
 10321 S. Medallion Dr.
 Cincinnati, OH 45241
 Phone: (704) 523-4400
 Fax: (704) 523-4499

Install To
 Anthony Ashley
 Uber Heights Police Department
 6121 Taylorsville Road
 Huber Heights, OH 45424
 (937) 237-3590
 tashley@hhoh.org

Bill To
 , 45424

SALESPERSON	EMAIL	DELIVERY METHOD	PAYMENT METHOD
Gordon Kwiecinski	gkwiecinski@pattersonpoppe.com		Net 10

We are pleased to propose the following per Ohio STS 800859. Project pricing is "Turn Key" and includes material, freight, removal of existing and installation of all new materials. HHPD would be responsible for bringing electrical to locations as outlined below and final electrical hook-up.

Group Name	Description	Net Total
Spacesaver Free Style Lockers	Total of 63 lockers per Project Plan #336236 1A, September 14, 2022 as follows: 55 Lockers in the Men's Locker Room and 8 Lockers in the Women's Locker Room Each locker will have a full width shelf across the top with an integrated hanger shelf, vented vest rack in the top of the bottom drawer, sloped tops across all units and corners. Each locker will have two duplex receptacles above the top shelf in each locker. One with two grounded outlets and the second configured for USB plug-ins. Outlets are "daisy chained" via connections that are concealed within the sloped tops. Power in feed cables are designated by "EDS" on the project plan HHPD would drop power to these locations and be responsible for final electrical hook up. All internal wiring is included in our pricing. (See attached Tech Data Sheet for additional information.)	\$104,078.44
Spacesaver Free Style Lockers USB Ports	63 USB Ports as described above.	\$7,297.00
Locker Room Benches	9 72" Benches as illustrated on Project Plan 336236,	\$5,791.00
Installation & Services	To include the following: <ul style="list-style-type: none"> • Removal of Existing Lockers according to agreed upon schedule. • Receiving and inspection at our local distribution company • Delivery to HHPD in phases • Installation of new lockers in phases • Trash removal and clean-up • User orientation • All work to be performed during normal working hours 	\$29,993.00

Sub Total:	\$147,159.44
Estimated Total Tax:	
Grand Total:	\$147,159.44

Important Proposal Notes

Applicable sales tax and final shipping charges will be added to the invoice if not indicated above.

Patterson Pope requires a purchase order (or signed quote) for each individual accepted quote.



Proposal

Quote #: Q-51140-1
Drawing Ver: 336236 1A
Date: 9/14/2022
Expires On: 12/13/2022

Patterson Pope

Remit To:
10321 S. Medallion Dr.
Cincinnati, OH 45241
Phone: (704) 523-4400
Fax: (704) 523-4499

Please provide sign off on final drawing(s). Indicate color choices on your PO.

Patterson Pope offers custom manufactured solutions to fit your unique space. For this reason no product can be ordered until a representative from Patterson Pope is able to field verify all dimensions.

Signature below indicates acceptance of this proposal and of the attached terms and conditions.

Signature: _____ **Effective Date:** ____/____/____
Name (Print): _____ **Title:** _____

Please sign and email to Gordon Kwiecinski at gkwiecinski@pattersonpope.com.
THANK YOU FOR YOUR BUSINESS!

Patterson Pope Terms and Conditions The following terms and conditions shall apply to any Deliverables (defined herein) provided by Patterson Pope, Inc. ("Company") to Client.

1. **Acceptance and Agreement:** The provisions on the pricing page, the purchase order and these Terms and Conditions (collectively, the "Agreement") constitute the entire agreement between Company and Client and supersede all other communications between the parties, whether written or oral, regarding the products and services described in this Agreement ("Deliverables"). The terms of this Agreement are expressly limited to those provided herein, and no purported modification, addition, or waiver of the provisions hereof shall be binding on Company for any purposes unless contained in writing, signed by an authorized representative of Company. The provisions hereof shall be deemed to have been accepted by Client's acceptance of all or any part of the Deliverables. All orders or any changes to such orders shall be subject to acceptance by Company. Change orders requested after receipt of Client purchase order may also incur additional charges. If, for any reason, Client cancels the order, any cancellation, restocking and handling charges will be invoiced. Future purchase orders (or similar engagement documents) and associated pricing pages may reference these Terms and Conditions, and by such reference, these Terms and Conditions shall be incorporated therein.

2. **Payment and Pricing:** Pricing quoted on the pricing page supersedes all previously quoted prices and is good for 60 days from the date of this Agreement. The pricing page may or may not include applicable sales or other taxes required by law; such taxes will be billed to Client and are Client's sole responsibility. This system has been custom designed and will be specially manufactured for your unique requirements. A non-refundable down payment of 40% is due upon order, 30% is due at the time of shipment and 30% is due at the time of completion. Client shall have no authority to assert any offsets or discounts against any payment due, except as expressly agreed to by Company in the pricing page or other signed writing. Client represents and warrants to Company that it is solvent at the time this Agreement is made. Client hereby grants a security interest in the product Deliverables to secure payment to Company and consents to Company filing a financing statement to perfect such security.

3. **Space Requirements:** This system has been specially designed to meet Client's specific requirements; as such, most of the equipment is manufactured on a "per job" basis. Client shall allow Company's representative(s) reasonable access to Client's facilities to confirm whether the space where the Deliverables will be installed matches Client's representations. In the event that the space cannot be field verified before the Deliverables must be ordered and the actual space does not match what had been previously represented, Client is responsible for any delays and additional costs incurred to reconfigure the Deliverables to fit actual space (i.e. extra material, labor, and freight). Notwithstanding any field verification by Company, it is Client's responsibility to be certain the space is suitable for the installation of this equipment (i.e. adequate fire protection and floor load capacity).

4. **Acceptance:** Client shall accept the Deliverables which conform to the requirements of specifications under this Agreement. All claims for errors, shortages, or damage ("Non-conformance") must be made in writing to the respective Account Representative within ten (10) days of Client's receipt of any Deliverables, and Company shall have a reasonable period of time, based on the severity and complexity of the Non-conformance, to correct the Non-conformance. If Client uses the Deliverables before acceptance or fails to promptly notify Company of any Non-conformance then the Deliverables shall be considered accepted by the Client.

5. **Freight and Shipping:** Freight and shipping terms are detailed on the pricing page. In the event that Client or one of its agents refuses delivery for whatever reason on or after the estimated delivery date, Client will be responsible for the payments in accordance to Section 2 and the pricing page in addition to any supplemental storage charges incurred by Company as a result of the delay *unless* the delay is caused by Company, one of its manufacturers, freight carriers, subcontractors, and/or any other agent acting on Company's behalf.

6. **Limited Warranty:** Company warrants its installation services under the Agreement shall be performed with reasonable care in a diligent and competent manner. Company's sole obligation under this warranty shall be to correct any Non-conformance, provided that Client gives Company written notice within ten (10) days after installation is completed. Company does not warrant and is not responsible for any product Deliverables or third party services. Client agrees to look to the third party manufacturer or vendor (and not Company) with respect to all claims regarding such third party products or services as its sole and exclusive remedy. *This section is Company's only warranty concerning the product and service Deliverables, and is made expressly in lieu of, and to disclaim, all other warranties and representations, express or implied, including any implied warranties of merchantability, non-infringement, or fitness for a particular purpose, or otherwise.*

7. **Limitation of Remedy and Liability:** *The maximum liability of Company and Company's principals, directors, officers, agents, employees, personnel, affiliates and their partners shall be the fees Company actually receives under the Agreement for the portion of work giving rise to the liability. In no event shall any of the above be liable to Client or any third party for any indirect, special, incidental, consequential, exemplary or punitive damages of any kind whatsoever in connection with the agreement, including but not limited to lost profits, loss of business opportunity, lost savings, and loss of business information.* Client will bear the risk of loss or damage to, or theft of, any Deliverables once delivery has been made to the Client. Any action against Company must be brought within twelve (12) months after the cause of action arises. Neither party shall be liable for any delays or failures in performance due to circumstances beyond its reasonable control, including but not limited to, strikes, riot, war, fire, flood, storm, explosion, accident, or other acts of God. This contract shall be construed in accordance with the laws of the State of North Carolina (without regard to its choice of law provisions). Claims arising out of or requiring the interpretation of this Agreement shall be brought and litigated exclusively in courts located

within Mecklenburg County, North Carolina, or if a federal court, the court whose district includes Mecklenburg County, North Carolina. This Agreement may not be assigned without prior written consent; provided, however, Company may assign this Agreement in whole or in part, without the Client's consent, in connection with a merger, acquisition, corporate reorganization, or sale of substantially all of the Company's assets, and Client agrees that Company shall be released from any further obligations under this Agreement upon such assignment.

Patterson Pope, Inc.

Date

CLIENT

Date

(This Agreement may be signed in counterparts and by facsimile or electronic signature by an authorized representative.)

Purchase Order # _____

SPACE MADE SIMPLE

AREA 5
6 LOCKERS

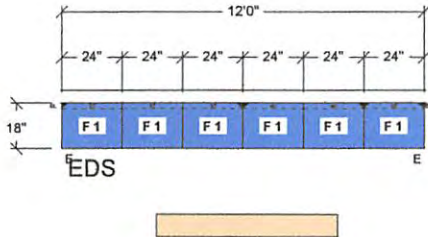

WOMEN'S AREA 1
6 LOCKERS
(TAG 1-6)

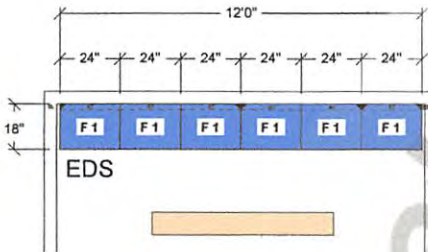

WOMEN'S AREA 2
2 LOCKERS
(TAG 7-8)

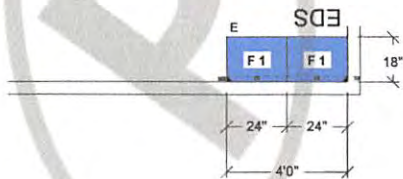

Project Name: LOCKER ROOM RENOVATION

Salesperson:
KWIECINSKI, GORDON

Scale
1/4" = 1'

Rev level:

Project #:
336236 1A
Drawn by:
K. KELLY
Date Printed:
09/14/2022

APPROVAL
This drawing Approved By:

Dated: _____

**AREA 4
17 LOCKERS
(TAG 32-49)**

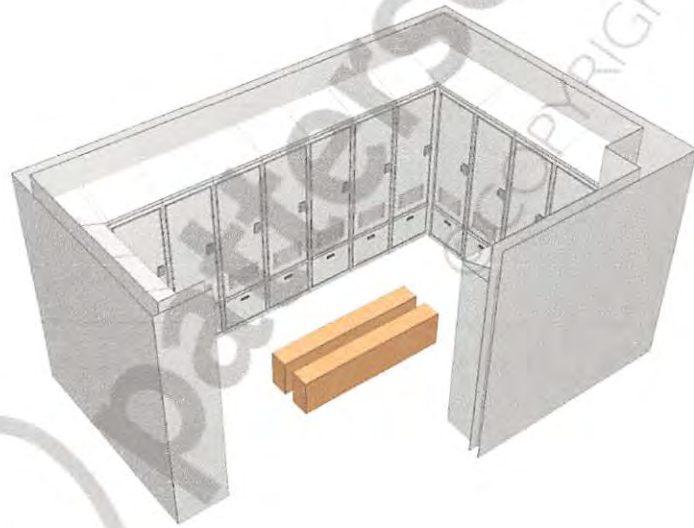
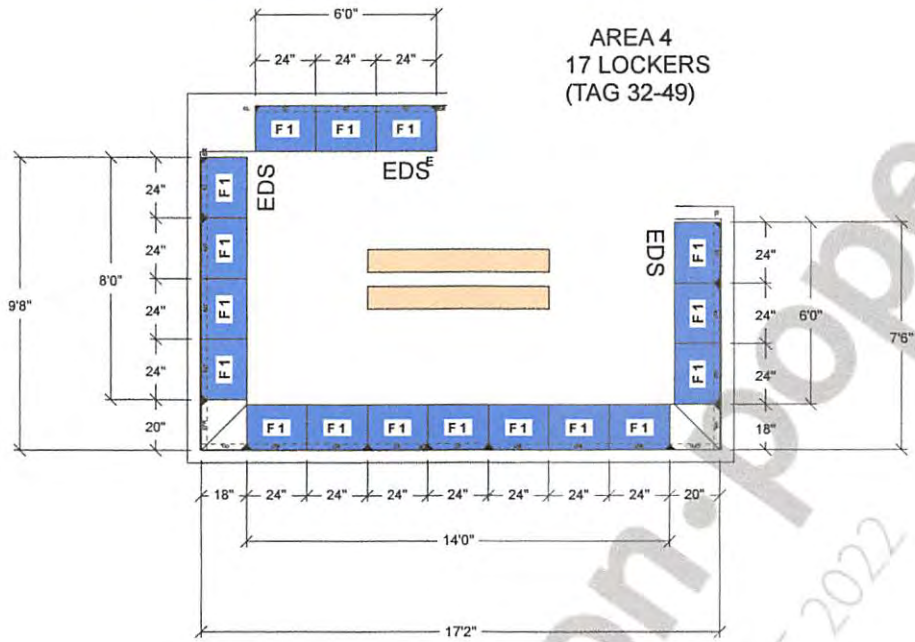

24"W x 18"D x 84"H (92"H TOTAL)

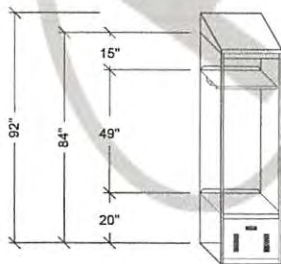

F1

- FEATURING:**
- BODY ARMOR DRYING RACK
 - USB/POWER PLUGS

Phase of Power Feeds: Single Three

Power feed length: 24" 72" 144"

Required Watts per duplex:

Duplex receptacles per locker: One Two

Circuits per feed:

Lockers per circuit:

**Consult local building electrical codes for deviation from National Electrical Codes (NEC).
Please contact your local building authority on applicable building codes.**



Project Name: LOCKER ROOM RENOVATION

Salesperson:
KWIECINSKI, GORDON

Scale
1/4" = 1'

Rev level:

Project #:
336236 1A
Drawn by:
K. KELLY
Date Printed:
09/14/2022

APPROVAL
This drawing Approved By:

Dated: _____

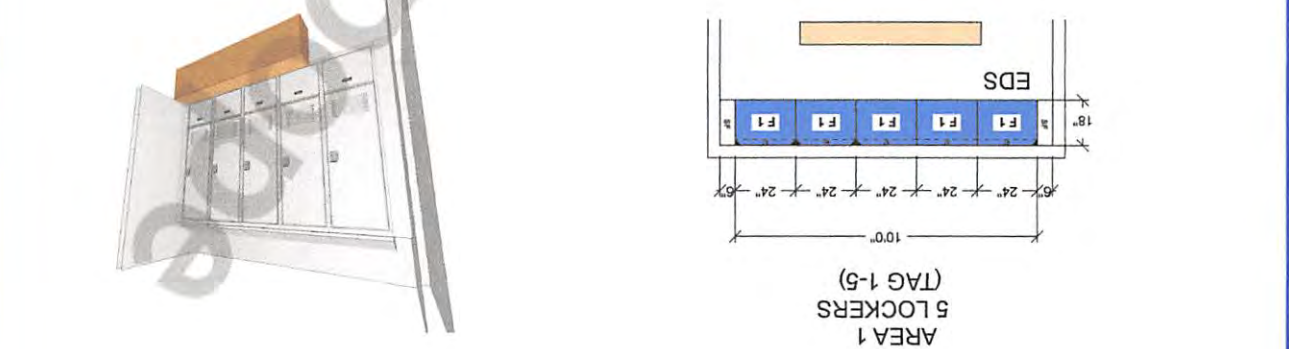
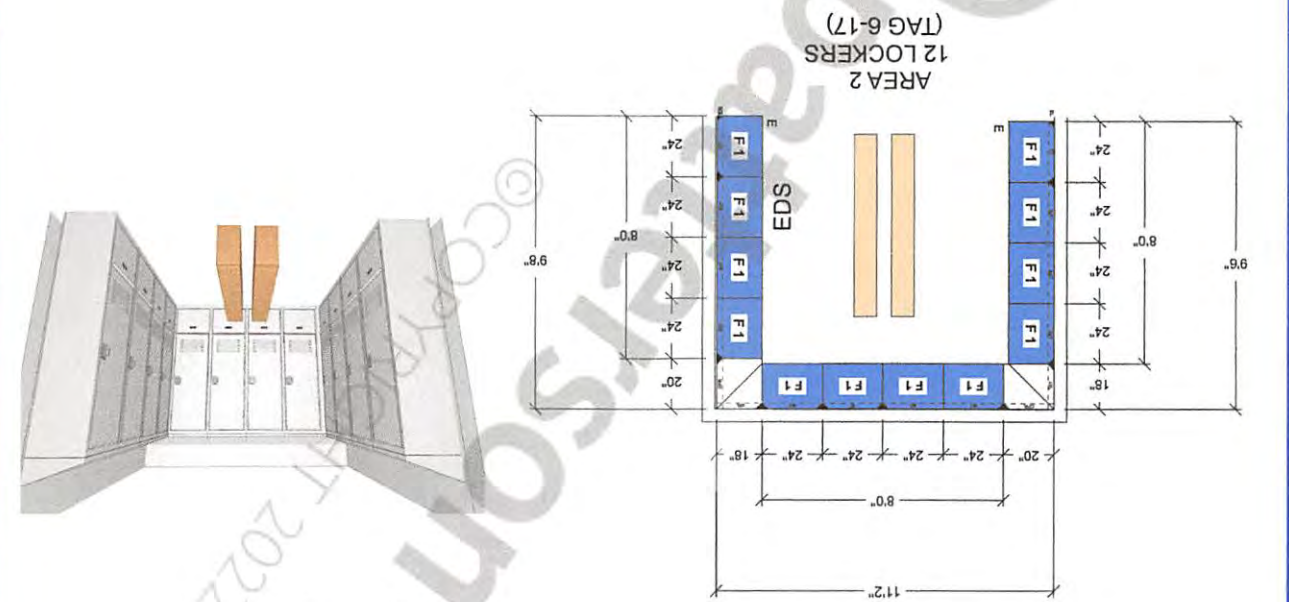
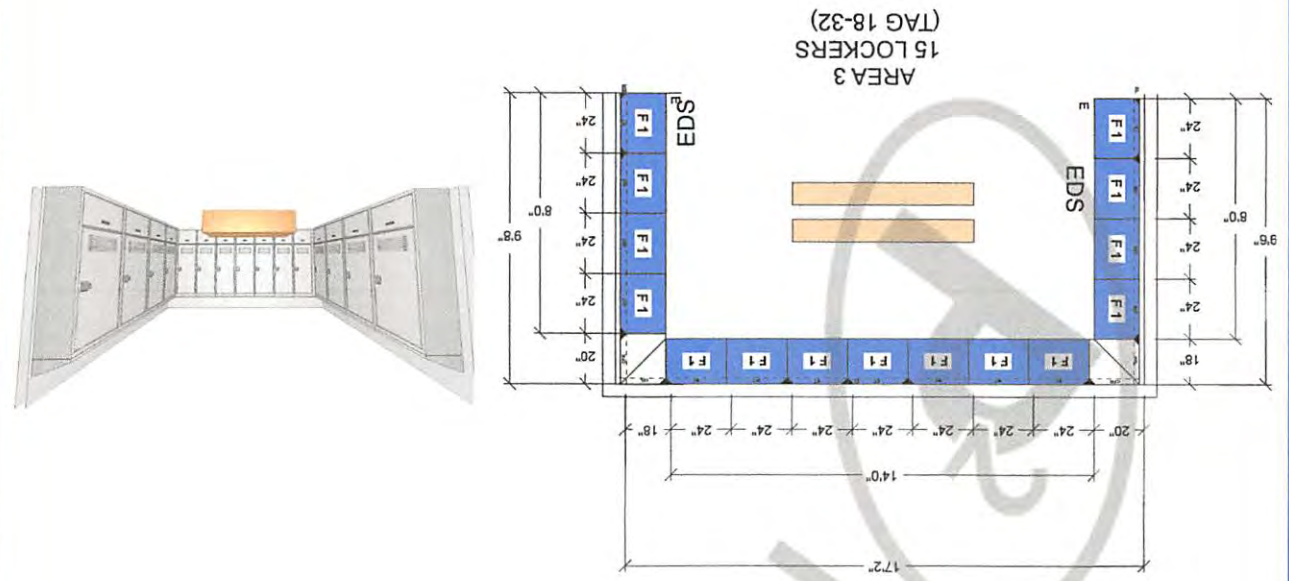

COPYRIGHT © 2020 SPACESAVER CORPORATION. ALL RIGHTS RESERVED.

STATEMENT OF WARRANTY

Weapons Rack, Firearms Storage, and Lockers

Spacesaver has an emphasis on customer satisfaction and continuous improvement. The statement of warranty is our continued commitment that Spacesaver is dedicated to serving our customers.

LIFETIME LIMITED WARRANTY

Subject to the conditions stated below, Spacesaver Corporation ("Spacesaver") warrants to the original purchaser exclusively that the cabinets ("structural frames") manufactured by it will be free from defects in materials and workmanship for the lifetime of the structural frames. For the purposes of this warranty, structural frames shall be deemed to exclude all moving parts (doors, slides, hinges, and lock mechanism), removable accessories, vinyl coating, electronics and refrigeration equipment.

1-YEAR LIMITED WARRANTY

Spacesaver also warrants that all refrigeration units, shall be free from defects in materials and workmanship for one (1) year from the date of the customer's written acceptance of installation. During the 1-year warranty period, all parts are included at no cost for 1 years. Labor is included at no cost during the first year of the 1-year warranty period. After the first year of the 1-year warranty, all labor will be charged at the current rate.

5-YEAR LIMITED WARRANTY

Spacesaver also warrants that all equipment, other than structural frames and refrigeration units, shall be free from defects in materials and workmanship for five (5) years from the date of the customer's written acceptance of installation. During the 5-year warranty period, all parts are included at no cost for 5 years. Labor is included at no cost during the first year of the 5-year warranty period. After the first year of the 5-year warranty, all labor will be charged at the current rate.

Spacesaver also warrants that all electronics associated with a ControlLoc™ Technology installation, shall be free from defects in materials and workmanship for five (5) years from the date of the customer's written acceptance of installation or 30 days after shipment. Limited warranty specific to ControlLoc electronics is conditioned upon the end user "activating" their warranty at www.spacesaver.com. During the 5-year warranty period, all parts are included at no cost for 5 years. Labor is included at no cost during the first year of the 5-year warranty period. After the first year of the 5-year warranty, all labor will be charged at the current rate.

If any warranted equipment shall be proved to Spacesaver's satisfaction to be defective, such equipment shall be repaired or replaced at the option of Spacesaver. All warranty service for any equipment manufactured by Spacesaver must be performed by an authorized Spacesaver factory representative. This warranty shall be void if any portion of the purchase price shall be due but unpaid in accordance with the terms pursuant to which the equipment was sold. This warranty shall not apply to equipment repaired by any party other than an authorized Spacesaver factory representative or to defects or damage caused by (a) acts of God or other circumstances beyond Spacesaver's control, (b) improper installation (unless installation was by authorized factory installer), (c) improper environmental conditions, (d) improper operation, maintenance or storage, or (e) other than normal use or service. **EXCEPT FOR THE EXPRESS WARRANTIES SET FORTH ABOVE, SPACESAVER MAKES NO WARRANTIES, IMPLIED OR OTHERWISE, AND SPACESAVER SPECIFICALLY DISCLAIMS ANY IMPLIED WARRANTY OF MERCHANTABILITY OR FITNESS FOR A PARTICULAR PURPOSE.**

LIMITATION OF LIABILITY

Repair or replacement of any defective equipment, or refund of the purchase price paid by the customer in the event Spacesaver determines such equipment cannot be repaired or replaced, shall be the customer's exclusive remedy for breach of the warranty for product defects, however caused, and in no case shall Spacesaver be liable for incidental, consequential, special or other damages, or loss of profits or revenues whether as a result of breach of contract or warranty, Spacesaver's negligence, or otherwise. Spacesaver shall have no liability for any advice or assistance rendered by any party outside the scope of Spacesaver's written specifications for the manufacture, operation or maintenance of the warranted equipment.



PLANNING GUIDE

FreeStyle® Personal Storage Locker Electrical Distribution System (EDS)

The purpose of this document is to provide some general guidance with reference to the electrical distribution systems (EDS) being offered with the FreeStyle (PSL) product line.

IMPORTANT: It is recommended that the customer consult with a qualified electrician in their final layout of circuits that feed the electrical distribution systems. Branch-circuit requirements must comply with National Electric Codes (NEC), and other local building requirements.

Note: The electrical distribution system covered in this guide is for typical North American application. Other international applications should be reviewed by local jurisdiction.

ELECTRICAL COMPONENTS

There are a few different components used for providing power to and between FreeStyle lockers:

Duplex Receptacles

- Typically one duplex receptacle is used per locker, but a two duplex receptacle is available.
- Each duplex receptacle is pre-configured to connect to one of six circuits (plug-and-play). The circuit number that the receptacle connects to is thermally imprinted on the face of each receptacle.
- Two versions of duplex receptacles available;
 - Standard or Ground Fault Interruptible (GFI). (GFI version is only available via pick-list.)

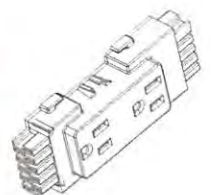

Distribution Blocks

- The receptacles connect to the distribution blocks.
- The distribution blocks hold the receptacles in place. They are mounted to the top of a locker.
- Two receptacles housed per block. Full distribution block feeds two lockers.
- Two versions of blocks:
 - FULL (two receptacles) or HALF (one receptacle)

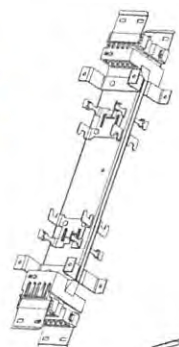

Jumpers

- Jumpers (Plug-to-Plug) provide connection between distribution blocks.
- They have plugs on two ends.
- Available in lengths: 12", 18", 24", 36", 49", 61", 72", 84", 96", 120"

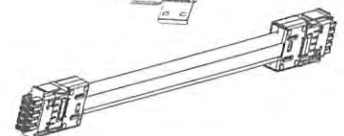

Power Feeds

- Power Feed cables provide input power to the distribution system.
- Typically, they can connect to any distribution block in the system.
- They have single plug on one end and connection wires (“pig tails”) at the other.
- Pig-tails are for connection to customer feed, typically a junction box provided by the customer (feed).
- Available in lengths: 24”, 72”, 144”
- One (1) Power Feed can typically support a total of six (6), twenty (20) amp branch-circuits.

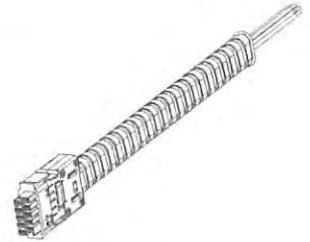

SITE CONSIDERATIONS

It is important to gather basic information from the project site in order to provide the best possible electrical distribution solution to the customer. The minimum information is to find out the amps or watts required per locker.

Spacesaver recommends asking the project architect, if possible, and remain conservative in terms of providing enough power to each locker.

Different electrical gadgets require differing amounts of power. This information is typically found on the devices themselves.

Examples may include:

- Cell-phone charger = 0.15 Amps (Watts = 16.5)
- Laptop charger = 2.4 Amps (max when powering and charging laptop; Watts = 264)
- Hair Dryer = 16 Amps (1800 Watts)

For Example: A twenty (20) amp branch circuit on a 120 volt system can support approximately 2400 Watts. That’s 150 cell-phone chargers, or a couple of hair-dryers.

A conversation with the architect or the owner about the load in each locker is imperative!

Additional information to gather about the project might include:

- Planned location of various junction boxes providing power to the locker runs.
- Are there sloped tops involved? (Sloped tops are recommended to cover the EDS)
 - Will power enter into the sloped tops from the wall, or from the ceiling, or from the end-panels? (See FreeStyle Sloped Top Planning guide for additional information on sloped tops.)
- Will the end user require Ground Fault Circuit Interrupter (GFCI) in this project? If they do here are two options:
 - Utilize Spacesaver offered GFCI duplex receptacles; plan locker layout as you would with standard outlets, then utilize the Configura Picklist to replace standard duplex receptacles with GFCI receptacles.

- If architect/contractor specifies using a GFCI circuit breaker at the power distribution panel then you have to make some adjustments to your electrical layout planning. In this situation contact you Spacesaver Customer Support representative to review electrical options.

CONFIGURA

The Configura software is the tool to be used to draw and price the basic Electrical Distribution Systems (EDS) for projects. It is required that the user complete all locker runs/configurations before applying the electrical distribution system to their project.

This section will explain the information that must be collected to complete the “E-Spec” in Configura. For information on how to use EDS in Configura please refer to the Configura user guide. The E-Spec dialogue box can be found below.

E-Spec

Phase of Power Feeds: Single Three

Power feed length: 24" 72" 144"

Required Watts per duplex:

Duplex receptacles per locker: One Two

Circuits per feed:

Lockers per circuit:

Consult local building electrical codes for deviation from National Electrical Codes (NEC).
Please contact your local building authority on applicable building codes.

Accept Settings / Enable Electrical Configuration Cancel

Phase of Power Feeds

This selection influences the number of circuits available per distribution system. The options are “Single” phase or “Three” phase.

- With “single”-phase wiring, up to four (4) circuits can be supported per EDS;
- With “three”-phase wiring, up to six (6) circuits can be supported per EDS.

This may be a conversation worth having with the architect or owner early in the project. Especially if there will be a LARGE number of lockers (>40) required per run. It may be in the customer’s best interest to provide “three” phase power, were they may have been only planning “single” phase power.

Power Feed Length

One (1) power feed (PF) cable is provided with each locker run. The PF cables come in three lengths (24", 72" and 144"). Select the desired length using the radio buttons in the e-spec dialogue box.

Knowledge of where and how the power will be fed into the locker runs will be helpful in determining what length cable to request.

NOTE: Should the customer wish to feed through the "top" of a sloped top cover, Spacesaver has a cut-out template and a cover (PSLELEPFAC) available for this approach. Cover would need to be selected from pick-list.

Watts per Duplex

The watts entered in this field will be used to calculate the lockers per circuit. There is no default, you are required to enter a value between 90-2,400.

Duplex Receptacles per Locker

The watts entered in this field will be used to calculate the lockers per circuit. There is no default, you are required to enter a value between 90-2,400.

Circuits per Feed

The EDS provides for a maximum of 6 circuits per feed, or one circuit per "pig-tail." A "feed" initiates at a circuit breaker in the customer's electrical distribution box, so up to six (6) circuits can be used to feed a run of lockers.

This field will auto populate a value based on the phase of power feed selected. Single phase will result in 4 circuits per feed. Three phase will result in 6 circuits per feed.

Lockers per Circuit

The load information from the customer (amps or watts per locker) is used to determine the number of lockers per circuit. This field in Configura will be auto populated using information entered in the Watts per Duplex field and the Duplex Receptacles per Locker field. The following equation illustrates the number of lockers that can be served per circuit

$$\text{Lockers per circuit} = \frac{(2400 \div \text{duplex per locker})}{\text{Watts per duplex}}$$



Bonham Electric Inc.

Since 1959

Proposal

3521 Wrightway Rd
Dayton, OH 45424
Ph: 937-233-7662
Fax: 937-237-0300
www.jeffbonhamelectric.com

To:	Lt. Tony Ashley	From:	Shawn McDonald JT Mandich
Organization:	HHPD	Date:	9-26-22
Address:	6121 Taylorsville Rd, Huber Heights, OH 45424		
Phone / Fax:	937-237-3590	Quotation:	4050
Total Pages:	1		
Job Name:	Locker Room Drops	Email:	tashley@hhoh.org
Job Location:		Mobile:	

Thank you for allowing Bonham Electric to provide an estimate for your project.

Scope of Work:

- Install (3) ¾" home run conduits from existing electrical room through ceiling to designated locations in locker area.
- Install (12) 120V 20A circuits through new conduits to designated locations to feed new lockers.
- Install (12) cut in boxes with stainless steel plates at designated locations for locker feeds.
- Install (12) MC drops from new conduit runs to new cut in boxes for locker feeds.
- Terminate all and test.

I. Notes:

- A. Quote is based on the work being performed during first shift business hours.
- B. Quote is budgetary based on preliminary specs for locker receptacles.
- C. No permits or inspections are included in this quote.
- D. Engineered / stamped drawings are not included in this quote.

Thank You for your consideration, we greatly appreciate your business. *Shawn McDonald*

Warranty - New Construction

Limited only to materials and labor supplied and installed for one (1) year.

Bonham Electric Terms and Conditions: I hereby agree to pay in full upon completion. Projects lasting over 30 days will be billed out in monthly installments. In the event of default or non-payment, customer agrees to pay all legal fees, service charges, and court costs in full. Quote good for 30 days. All overdue invoices will be assessed a 3% service charge per month.

Should this transaction be governed by the Home Solicitation Sales Act the following conditions apply: I hereby agree to pay in full upon completion. In the event of default or non-payment, customer agrees to pay all legal fees, service charges, and court costs in full. Quote good for 30 days. All overdue invoices will be assessed a 3% service charge per month.

Signed:

Date:

Total:

\$10,964.00

CITY OF HUBER HEIGHTS
STATE OF OHIO

RESOLUTION NO. 2022-R-

AUTHORIZING THE CITY MANAGER TO ENTER INTO AN AGREEMENT WITH PATTERSON POPE TO PURCHASE NEW LOCKERS AND BENCHES FOR BOTH LOCKER ROOMS IN THE HUBER HEIGHTS POLICE DIVISION AND WAIVING THE COMPETITIVE BIDDING AND REQUEST FOR PROPOSALS REQUIREMENTS.

WHEREAS, there is a need to upgrade the lockers for both male and female officers of the Huber Heights Police Division and the current lockers are thirty years old, rusted and in disrepair; and

WHEREAS, purchases greater than \$25,000 require authorization by the City Council; and

WHEREAS, a local business donor has affirmed a \$100,000 donation toward the project; and

WHEREAS, a State Bid contract is available from vendor Patterson Pope for new Spacesaver Technology lockers inclusive of hanger shelf, vented vest rack, drawer and grounded power receptacles suitable for the technology needs of officer equipment.

NOW, THEREFORE, BE IT RESOLVED by the City Council of Huber Heights, Ohio that:

Section 1. The City Manager is hereby authorized to purchase lockers and benches from Patterson Pope, a State of Ohio Cooperative Purchasing vendor and Council approves the budget and expenditure of money for such purpose at a cost not to exceed \$160,000.00.

Section 2. Consistent with provisions of the City Charter of Huber Heights and the Huber Heights Codified Ordinances Section 171.12 (a)(1), the competitive bidding requirements are hereby waived.

Section 3. It is hereby found and determined that all formal actions of this Council concerning and relating to the passage of this Resolution were adopted in an open meeting of this Council and that all deliberations of this Council and of any of its Committees that resulted in such formal action were in meetings open to the public and in compliance with all legal requirements including Section 121.22 of the Ohio Revised Code.

Section 4. This Resolution shall go into effect upon its passage as provided by law and the Charter of the City of Huber Heights.

Passed by Council on the _____ day of _____, 2022;
_____ Yeas; _____ Nays.

Effective Date:

AUTHENTICATION:

Clerk of Council

Mayor

Date

Date

AI-8848

New Business P.

City Council Special Meeting

Fire

Meeting Date: 12/15/2022

Apparatus Purchase - Fire Division

Submitted By: Keith Knisley

Department: Fire

Council Committee Review?: Council Work Session **Date(s) of Committee Review:** 12/06/2022

Audio-Visual Needs: None **Emergency Legislation?:** No

**Motion/Ordinance/
Resolution No.:**

Agenda Item Description or Legislation Title

A Resolution Authorizing The City Manager To Award Purchase Of A Fire Division Fire Engine With Sutphen Corporation Waiving The Competitive Bidding Requirements.
(first reading)

Purpose and Background

The Fire Division is requesting the purchase of a new fire engine. The replacement of this fire engine has been a planned replacement, having been part of the Fire Division's Capital Improvement Plan and is included in the 2023 budget. This vehicle will be placed into a front-line status allowing the 1997 KME fire engine (Engine 24) to be removed from inventory, and a 2006 Sutphen fire engine to move to a reserve/backup role.

The purchase of this new fire engine would be completed using the City's already established Sourcewell Purchasing Cooperative account to award the purchase contract to Sutphen Fire Apparatus. Sutphen, a family-owned Ohio-based company, has been a provider of fire apparatus to the Huber Heights Fire Division since 2006. The purchase and delivery of this Sutphen Fire Engine will provide a standardized platform encompassing the many components and functions as well as general capabilities and functions of operations to all Fire Division fire engines.

Due to current supply chain conditions and raw material cost increases as well as pending annual pricing increases, City Staff are asking City Council to pass the resolution and waive the competitive bidding requirement for Sutphen Fire Apparatus to supply the Fire Division with a fire engine for a cost to not exceed \$752,000 to facilitate the purchase prior to January 6, 2023. Understanding imminent price increases are set to go into effect on December 15, 2022, Sutphen has agreed to hold the current purchase price until 1/6/2023, so long as this resolution is passed prior to December 15, 2022. If the resolution is not passed prior to December 15, 2022 and the purchase agreement is not completed on or before January 6, 2023, the City Manager will be authorized to agree to payment up to \$802,000.

Fiscal Impact

Source of Funds: Fire Capital Fund

Cost: \$752,000

Recurring Cost? (Yes/No): No

Funds Available in Current Budget? (Yes/No): Yes

Financial Implications:

Attachments

Drawing
Proposal
Resolution

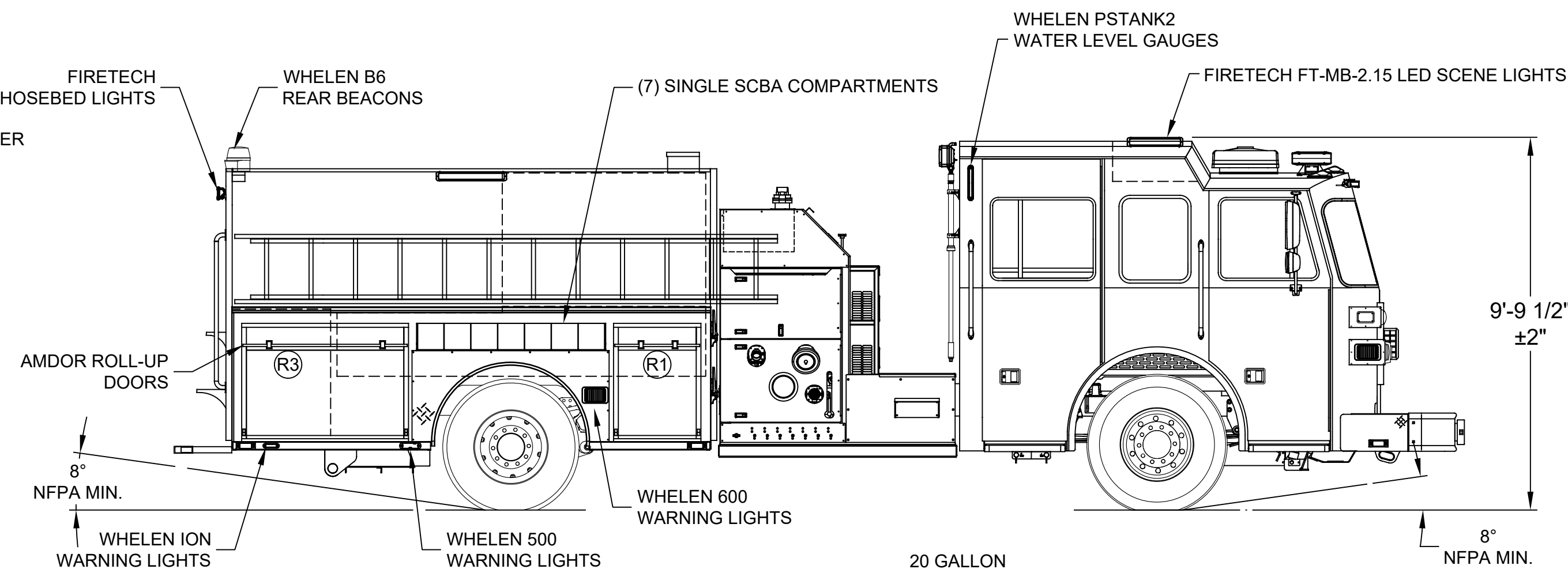
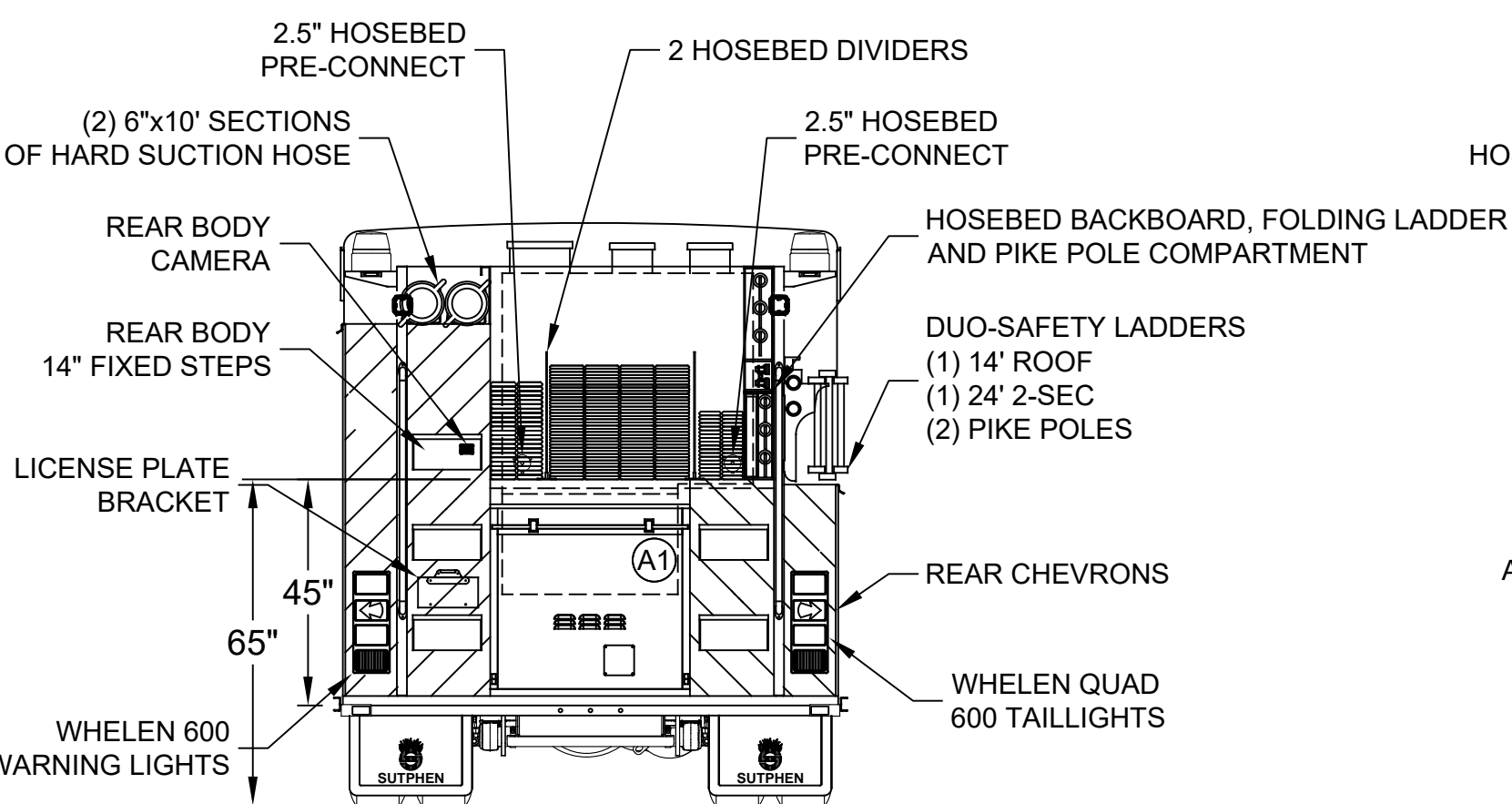

LEFT SIDE COMPARTMENTS				
COMPT	DOORS	OPENING DIMENSIONS	INSIDE DIMENSIONS	VOLUME
L1	ROLL-UP	25.5" w X 61.4" h	31.1" w X 72" h X 27.3" d	35.4 CU. FT.
L2	ROLL-UP	57.5" w X 32.2" h	61.6" w X 42.8" h X 27.3" d	41.6 CU. FT.
L3	ROLL-UP	50.5" w X 61.4" h	53.4" w X 72" h X 27.3" d	60.8 CU. FT.

RIGHT SIDE COMPARTMENTS				
COMPT	DOORS	OPENING DIMENSIONS	INSIDE DIMENSIONS	VOLUME
R1	ROLL-UP	25.5" w X 29.4" h	31.1" w X 40" h X 27.3" d	28.3 CU. FT.
R2	DROP DOWN	57.0" w X 7.3" h	59" w X 8.5" h X 28.5" d	8.2 CU. FT.
R3	ROLL-UP	50.5" w X 29.4" h	53.4" w X 40" h X 27.3" d	48.6 CU. FT.

REAR STEP COMPARTMENT				
COMPT	DOORS	OPENING DIMENSIONS	INSIDE DIMENSIONS	VOLUME
A1	ROLL-UP	37.5" w X 30.8" h	40" w X 40" h X 31" d	28.7 CU. FT.
TOTAL:				228.1 CU.FT.

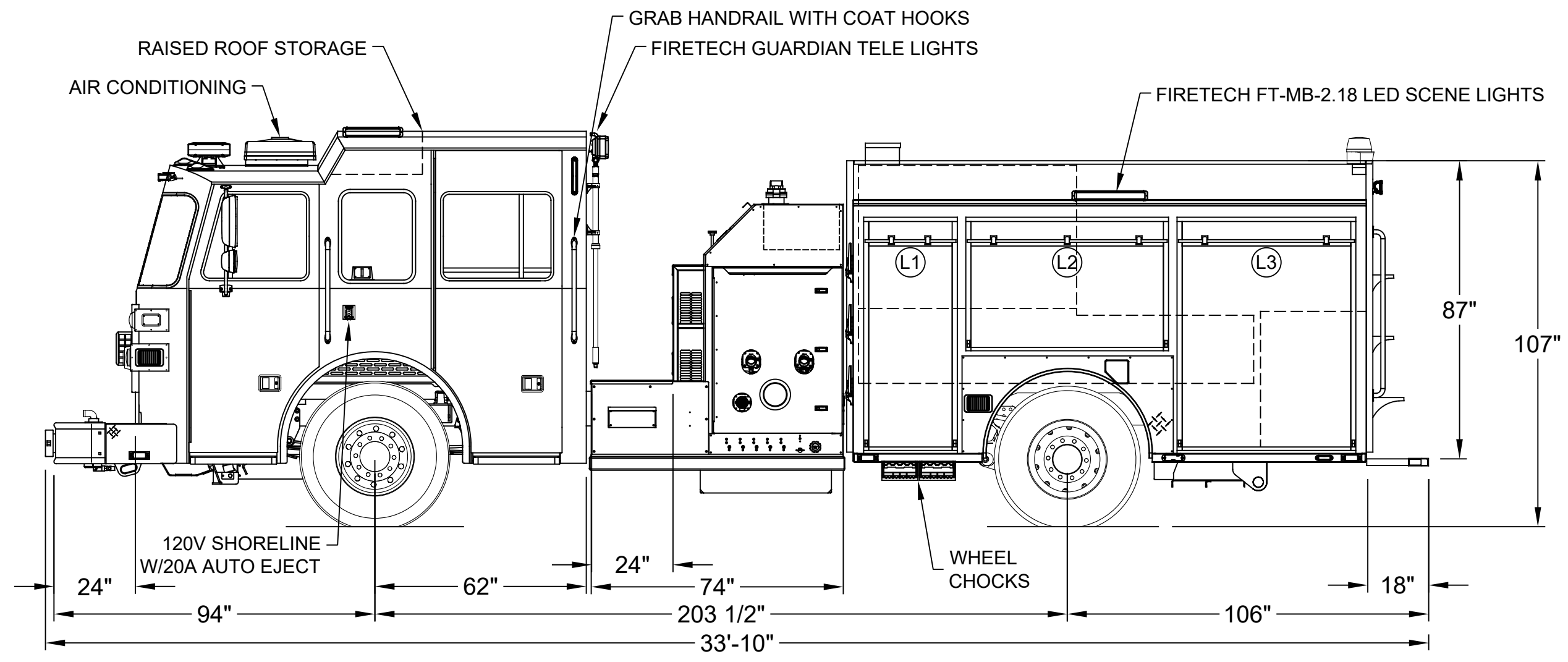
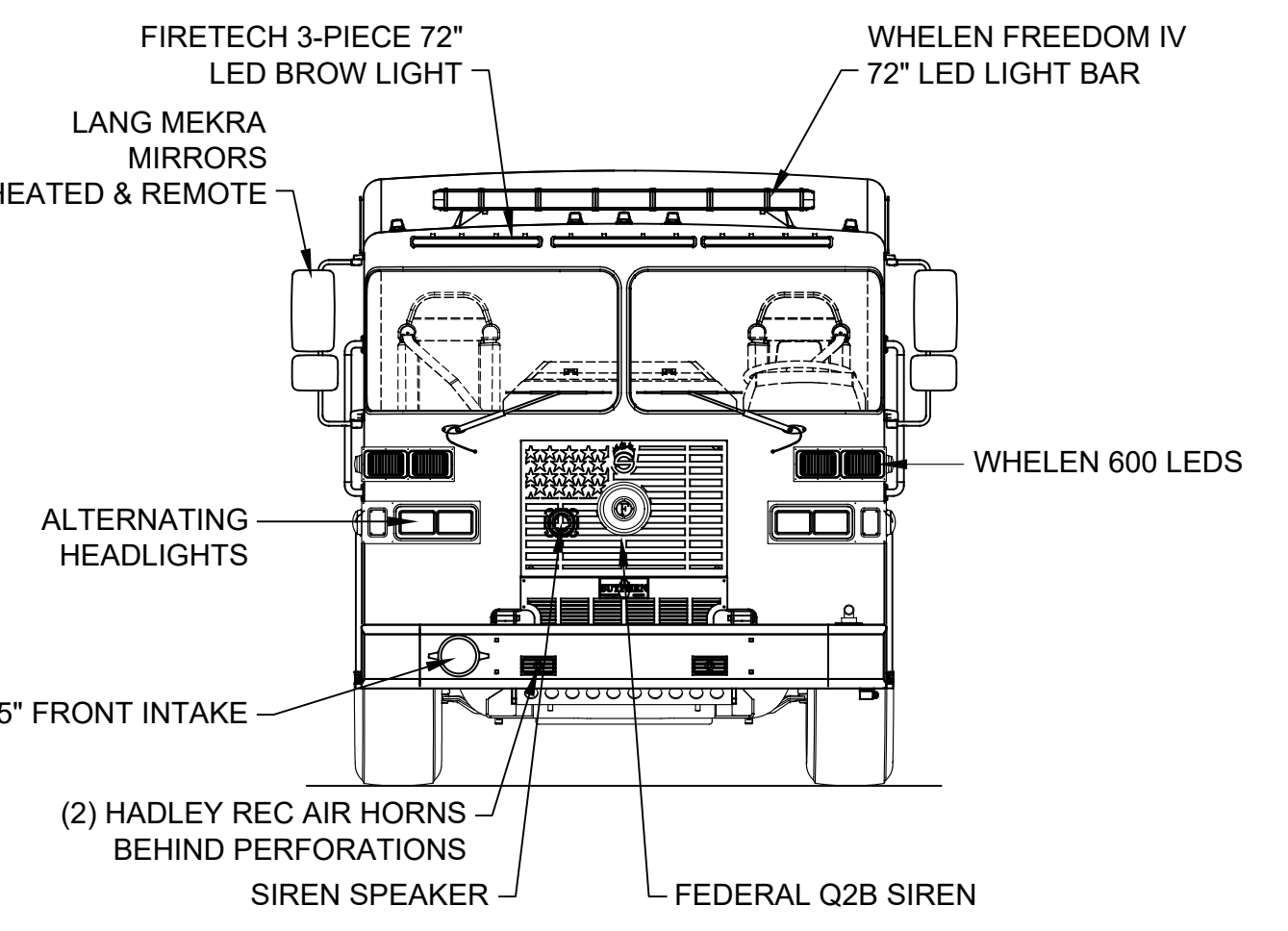
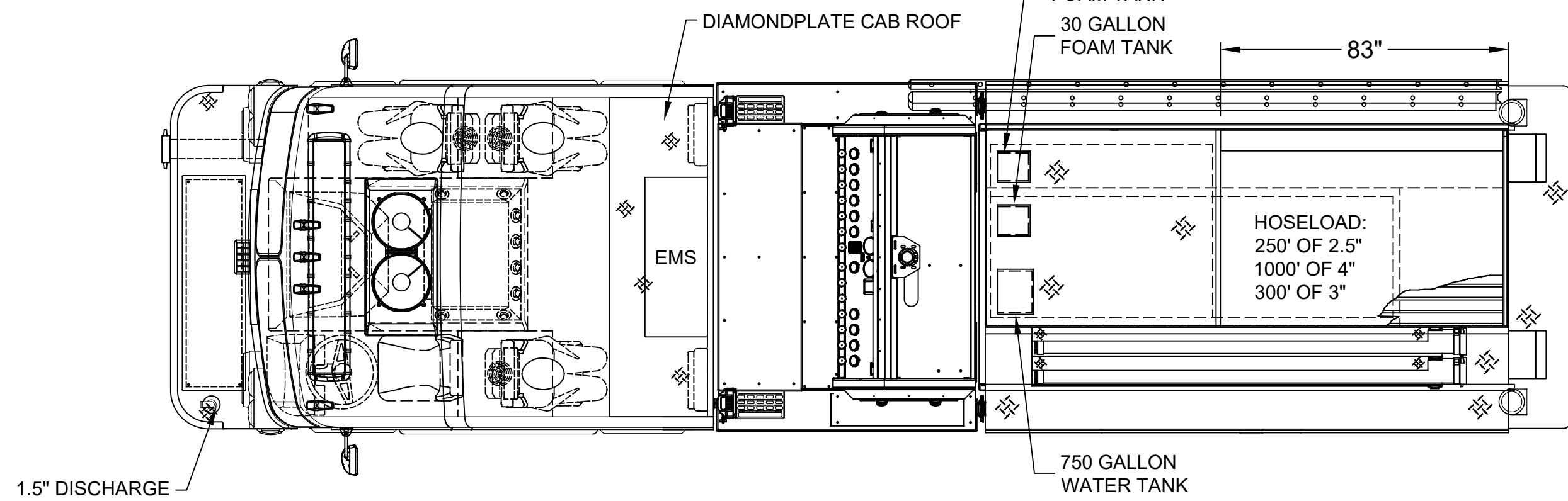

DIMENSIONS SHOWN ON THIS DRAWING ARE APPROXIMATE AND ARE SUBJECT TO MINOR DEVIATIONS DURING CONSTRUCTION.
 IN THE EVENT OF A DISCREPANCY BETWEEN THE SUTPHEN SPECIFICATIONS AND DRAWING, THE SUTPHEN SPECIFICATIONS SHALL PREVAIL.
 DRAWING IS FOR REFERENCE ONLY. SOME ITEMS PROPOSED MAY NOT BE SHOWN OR NOTED.

CUSTOMER APPROVAL

NAME: _____
 TITLE: _____
 DATE: _____

REV.	DESCRIPTION	BY	DATE

DATE: 11/23/2022
 DRAWN BY: J.HOWELL
 REVIEWER: K.EXEL
 APPROVER: D.NAYLOR
 MFG. FACILITY: DUBLIN

SUTPHEN
 HUBER HEIGHTS FIRE DEPARTMENT
 HUBER HEIGHTS, OH
 CUSTOM PUMPER - S1
 DWG. NO.: HUBER HEIGHTS, OH (2022 S1).DWG



SUTPHEN

PROPOSAL

TO THE:

Huber Heights Fire Department
Attn: Battalion Chief Mike Muhl
7008 Brandt Pike
Huber Heights, Ohio 45424

DATE: November 14, 2022

We hereby propose and agree to furnish the following firefighting equipment upon your acceptance of this proposal:

One (1) Sutphen Heavy Duty Custom pumper. Complete and Delivered for the

Total Sum of\$751,893.53

The unit shall be manufactured completely in accordance to the following proposal and delivered in approximately **28-30 months** from the date of the contract signing or purchase order, subject to delays from all causes beyond our control.

This proposal shall be valid for **thirty (30)** days. If the contract or purchase order is not received within this proposed duration, we reserve the right to extend, withdraw, or modify our proposal, including pricing, delivery times, and prepayment discounts as applicable.

Respectfully submitted,
Fredrick C. Hageman III
Heritage Fire Equipment
Authorized Representative for Sutphen Corporation
615-588-3815



SUTPHEN CORPORATION

6450 Eiterman Road | Dublin, OH 43016 | 1-800-848-5860

CITY OF HUBER HEIGHTS
STATE OF OHIO

RESOLUTION NO. 2022-R-

AUTHORIZING THE CITY MANAGER TO AWARD PURCHASE OF A FIRE DIVISION FIRE ENGINE WITH SUTPHEN CORPORATION WAIVING THE COMPETITIVE BIDDING REQUIREMENTS.

WHEREAS, the maintenance, repair and general upkeep of the Fire Division's Fire Apparatus fleet is necessary for the immediate preservation of the public peace, health, safety and welfare; and

WHEREAS, pricing for Sutphen Fire Apparatus has met all requirements of the Fire Division and is available through the Sourcewell purchasing cooperative Contract No. 022818-SUT; and

WHEREAS, as a recognized vendor with the Sourcewell purchasing cooperative, a bidding process has already been conducted and we are assured that pricing is as competitive of a price as is practical.

NOW, THEREFORE, BE IT RESOLVED by the City Council of Huber Heights, Ohio that:

Section 1. The City Manager is hereby authorized to contract with Sutphen Fire Apparatus for the purchase of a Fire Division fire engine not to exceed a cost of \$752,000.00 after January 1, 2023. Due to planned pricing increases, if the City fails to enter into a purchase agreement on or before January 6, 2023, the City Manager is authorized to pay up to \$802,000.00 for purchase of the fire engine.

Section 2. Consistent with the provisions of the City Charter and the Huber Heights Codified Ordinances, the competitive bidding requirements are hereby waived.

Section 3. It is hereby found and determined that all formal actions of this Council concerning and relating to the passage of this Resolution were adopted in an open meeting of this Council and that all deliberations of this Council and of any of its Committees that resulted in such formal action were in meetings open to the public and in compliance with all legal requirements including Section 121.22 of the Ohio Revised Code.

Section 4. This Resolution shall go into effect upon its passage as provided by law and the Charter of the City of Huber Heights.

Passed by Council on the _____ day of _____, 2022;
_____ Yeas; _____ Nays.

Effective Date:

AUTHENTICATION:

Clerk of Council

Mayor

Date

Date

AI-8849

**New Business Q.
Engineering**

City Council Special Meeting

Meeting Date: 12/15/2022

The Oaks Subdivision - Street Dedications

Submitted By: Stephanie Wunderlich

Department: Engineering **Division:** Engineering

Council Committee Review?: Council **Date(s) of Committee Review:** 12/06/2022
Work
Session

Audio-Visual Needs: None **Emergency Legislation?:** No

**Motion/Ordinance/
Resolution No.:**

Agenda Item Description or Legislation Title

A Resolution Accepting Certain Streets And Public Improvements For The Oaks Subdivision.
(first reading)

Purpose and Background

The City has approved the improvements for all streets in Section 9 of The Oaks subdivision. This section includes a portion of Silver Oak Way and Burr Oak Drive.

Fiscal Impact

Source of Funds: N/A

Cost: N/A

Recurring Cost? (Yes/No): N/A

Funds Available in Current Budget? (Yes/No): N/A

Financial Implications:

Attachments

Resolution

Exhibit A

CITY OF HUBER HEIGHTS
STATE OF OHIO

RESOLUTION NO. 2022-R-

ACCEPTING CERTAIN STREETS AND PUBLIC IMPROVEMENTS FOR THE OAKS
SUBDIVISION.

WHEREAS, the citizens of Huber Heights require the orderly and efficient establishment of
public improvements; and

WHEREAS, the City has approved the improvements for The Oaks Subdivision.

NOW, THEREFORE, BE IT RESOLVED by the City Council of Huber Heights, Ohio that:

Section 1. The public improvements and dedicated right-of-way in The Oaks Subdivision
include the following attached hereto as Exhibit A and are hereby accepted and approved:

All streets in Section 9:

Silver Oak Way from Fishburg Road to 4155 Silver Oak Way
Burr Oak Drive from Silver Oak Way to 3044 Burr Oak Drive

Section 2. It is hereby found and determined that all formal actions of this Council
concerning and relating to the passage of this Resolution were adopted in an open meeting of this
Council and all deliberations of this Council and any of its Committees that resulted in such a
formal action were in meetings open to the public and in compliance with all legal requirements
including Section 121.22 of the Ohio Revised Code.

Section 3. This Resolution shall go into effect upon its passage as provided by law and the
Charter of the City of Huber Heights.

Passed by Council on the _____ day of _____, 2022;
_____ Yeas; _____ Nays.

Effective Date:

AUTHENTICATION:

Clerk of Council

Mayor

Date

Date

EXHIBIT A



CHANNING
WAY

CHANNING

-  Streets To Be Dedicated
-  Dedicated Huber Streets
-  Private Streets



The Oaks of Huber Heights
Section 9

AI-8850

**New Business R.
Engineering**

City Council Special Meeting

Meeting Date: 12/15/2022

Carriage Trails Subdivision - Street Dedications

Submitted By: Stephanie Wunderlich

Department: Engineering **Division:** Engineering

Council Committee Review?: Council **Date(s) of Committee Review:** 12/06/2022
Work
Session

Audio-Visual Needs: None **Emergency Legislation?:** No

**Motion/Ordinance/
Resolution No.:**

Agenda Item Description or Legislation Title

A Resolution Accepting Certain Streets And Public Improvements For The Carriage Trails Subdivision.
(first reading)

Purpose and Background

The City has approved the improvements for the Carriage Trails Subdivision. The following are the streets that are hereby accepted and approved: Snowdrop Court, Lakeside Street from White Ash Drive to Honeylocust Street, White Ash Drive from Lakeside Street to the older Huber Subdivision, Boxelder Drive from White Ash Drive to Honeylocust Street, Blue Ash Drive from Forestedge Street to Red Buckeye Drive, Forestedge Street from 4141 to 4192, Cherry Birch Drive from 8136 to the end of the cul-de-sac, Arbor Drive, Lupine Way, Vervain Way, and Trillium Way.

Fiscal Impact

Source of Funds: N/A

Cost: N/A

Recurring Cost? (Yes/No): N/A

Funds Available in Current Budget? (Yes/No): N/A

Financial Implications:

Attachments

Carriage Trails - Street Dedication Plan 2022
Resolution

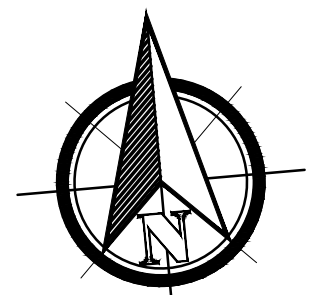

GRAPHIC SCALE

300 150 0 300

(IN FEET)
1 inch = 300 ft.

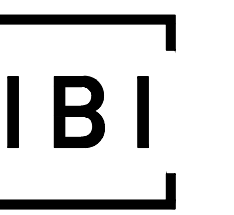

DEFINING THE CITIES
OF TOMORROW

23 Triangle Park Drive, Suite 2300
Cincinnati, OH 45246
Contact: Jeff Koehn
513-942-3141 ext. 232
Fax: 513-881-2263
www.ibigroup.com

SUBMISSION:

REVISION:

12/13/09	REVISED LAYOUT PER KEN
3/16/10	REVISED LAYOUT PER KEN
6/2/10	REVISED LAYOUT PER KEN
7/28/10	REVISED LAYOUT PER KEN
8/2/10	REVISED LAYOUT PER KEN
1/11/12	REVISED LAYOUT PER KEN
1/25/13	REVISED LAYOUT PER KEN
8/7/13	REVISED LAYOUT PER KEN
9/29/13	REVISED LAYOUT PER KEN
2/25/14	REVISED LAYOUT PER KEN
9/02/14	REVISED LAYOUT PER KEN
10/14/14	REVISED LAYOUT PER KEN
1/22/15	REVISED LAYOUT PER KEN
1/29/15	REVISED LAYOUT PER BILL
3/09/15	REVISED LAYOUT PER KEN
4/08/15	REVISED LAYOUT PER KEN
4/23/15	REVISED LAYOUT PER KEN
8/05/15	REVISED LAYOUT PER KEN
7/18/16	REVISED LAYOUT PER KEN
7/28/17	REVISED LAYOUT PER KEN
7/31/17	REVISED LAYOUT PER KEN
8/21/17	REVISED LAYOUT PER KEN
8/23/17	REVISED LAYOUT PER KEN
7/12/18	REVISED LAYOUT PER KEN
8/08/19	REVISED LAYOUT PER KEN
8/13/19	REVISED LAYOUT PER KEN
7/31/20	REVISED LAYOUT PER KEN
4/21/21	REVISED LAYOUT PER KEN
1/25/22	REVISED LAYOUT PER KEN
7/22/22	REVISED LAYOUT PER KEN
8/1/22	REVISED LAYOUT PER KEN
11/2/22	REVISED LAYOUT PER KEN

STAMP:

NOT FOR CONSTRUCTION

HUBER HEIGHTS, OHIO

CARRIAGE TRAILS

PRELIMINARY PLAN

DESIGN	DRAFT	CHECK
JBK	EFR	JBK

ME NO.: 09-048

DATE: NOVEMBER, 2022

SCALE:

HORIZONTAL: 1" = 300'

VERTICAL: N/A

SHEET TITLE:

MASTER PAVING PLAN

SHEET NO.: 1/1

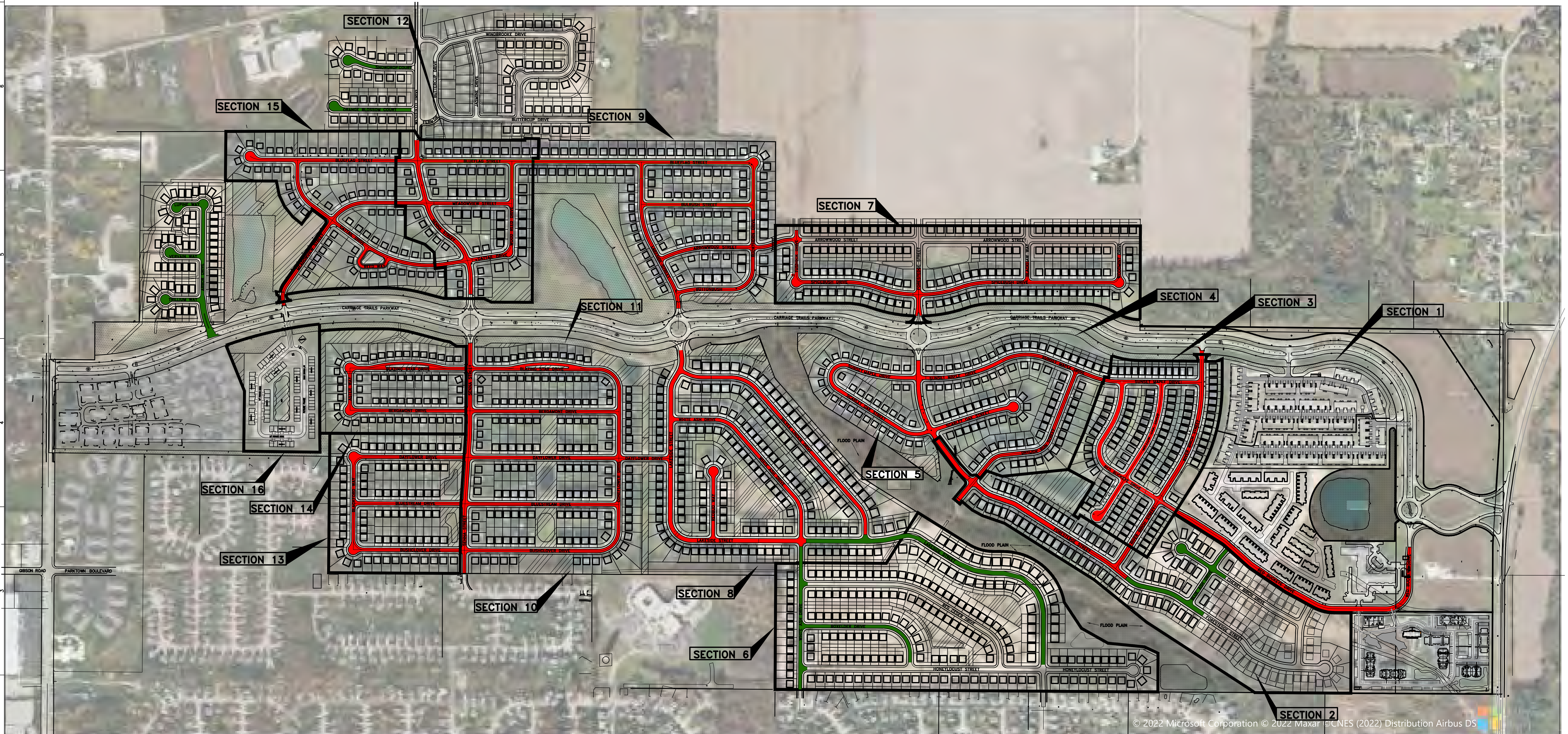

© 2022 Microsoft Corporation © 2022 Maxar ©CNES (2022) Distribution Airbus DS

- = PROPOSED FINAL PAVEMENT, 6.057 ACRES (263,838.56 SQ FT)
- = COMPLETED FINAL PAVEMENT, 31.341 ACRES (1,364,520 SQ FT)

CITY OF HUBER HEIGHTS
STATE OF OHIO

RESOLUTION NO. 2022-R-

ACCEPTING CERTAIN STREETS AND PUBLIC IMPROVEMENTS FOR THE CARRIAGE TRAILS SUBDIVISION.

WHEREAS, the citizens of Huber Heights require the orderly and efficient establishment of public improvements; and

WHEREAS, the City has approved the improvements for the Carriage Trails Subdivision.

NOW, THEREFORE, BE IT RESOLVED by the City Council of Huber Heights, Ohio that:

Section 1. The public improvements and dedicated right-of-way in the Carriage Trails Subdivision include the following and are hereby accepted and approved:

Snowdrop Court
Lakeside Street from White Ash Drive to Honeylocust Street
White Ash Drive from Lakeside Street to the older Huber Subdivision
Boxelder Drive from White Ash Drive to Honeylocust Street
Blue Ash Drive from Forestedge Street to Red Buckeye Drive
Forestedge Street from 4141 to 4192
Cherry Birch Drive from 8136 to the end of the cul-de-sac
Arbor Drive
Lupine Way
Vervain Way
Trillium Way

Section 2. It is hereby found and determined that all formal actions of this Council concerning and relating to the passage of this Resolution were adopted in an open meeting of this Council and all deliberations of this Council and any of its Committees that resulted in such a formal action were in meetings open to the public and in compliance with all legal requirements including Section 121.22 of the Ohio Revised Code.

Section 3. This Resolution shall go into effect upon its passage as provided by law and the Charter of the City of Huber Heights.

Passed by Council on the _____ day of _____, 2022;
_____ Yeas; _____ Nays.

Effective Date:

AUTHENTICATION:

Clerk of Council

Mayor

Date

Date

AI-8851

**New Business S.
Engineering**

City Council Special Meeting

Meeting Date: 12/15/2022

Fishburg Road/Endicott Road Storm Culvert Replacement - Award Contract

Submitted By: Hanane Eisentraut

Department: Engineering **Division:** Engineering

Council Committee Review?: Council **Date(s) of Committee Review:** 12/06/2022
Work
Session

Audio-Visual Needs: None **Emergency Legislation?:** No

**Motion/Ordinance/
Resolution No.:**

Agenda Item Description or Legislation Title

A Resolution Authorizing The City Manager To Enter Into A Contract For Fishburg Road/Endicott Road Storm Culvert Replacement Project And Waiving The Formal Bidding Requirements.
(first reading)

Purpose and Background

Two quotes were received for the Fishburg Road/Endicott Road Storm Culvert Replacement project from C.G. Construction at a cost of \$31,675 and from T.C. Holzen at a cost of \$55,600. A third contractor that was contacted did not provide any estimate. This legislation will authorize the City Manager to enter into a contract for the replacement of the 24" culvert at Fishburg Road/Endicott Road and to waive the formal bidding requirements. The Storm Sewer Fund will be utilized for the construction of this project.

Fiscal Impact

Source of Funds: Storm Sewer Fund

Cost: \$40,000

Recurring Cost? (Yes/No): No

Funds Available in Current Budget? (Yes/No): Yes

Financial Implications:

Attachments

Map

Resolution



**STORM
PIPE
LOCATION**



1 in = 400 ft

City of Huber Heights

Date: 11/28/2022



CITY OF HUBER HEIGHTS
STATE OF OHIO

RESOLUTION NO. 2022-R-

AUTHORIZING THE CITY MANAGER TO ENTER INTO A CONTRACT FOR FISHBURG ROAD/ENDICOTT ROAD STORM CULVERT REPLACEMENT PROJECT AND WAIVING THE FORMAL BIDDING REQUIREMENTS.

WHEREAS, the cost of the project will be in excess of \$25,000; and

WHEREAS, City Council may waive the competitive bidding procedures whenever it deems to be in the best interest of the City to do so as defined in Section 171.12 of the Codified Ordinances of Huber Heights.

NOW, THEREFORE, BE IT RESOLVED by the City Council of Huber Heights, Ohio that:

Section 1. The City Manager is hereby authorized to contract with C G Construction & Utilities, Inc. for Fishburg Road/Endicott Road Storm Culvert Replacement project at a cost not to exceed \$40,000.00.

Section 2. Consistent with the provisions of the City Charter and the Huber Heights Codified Ordinances, the competitive bidding requirements are hereby waived.

Section 3. It is hereby found and determined that all formal actions of this Council concerning and relating to the passage of this Resolution were adopted in an open meeting of this Council and that all deliberations of this Council and of any of its Committees that resulted in such formal action were in meetings open to the public and in compliance with all legal requirements including Section 121.22 of the Ohio Revised Code.

Section 4. This Resolution shall go into effect upon its passage as provided by law and the Charter of the City of Huber Heights.

Passed by Council on the _____ day of _____, 2022;
_____ Yeas; _____ Nays.

Effective Date:

AUTHENTICATION:

Clerk of Council

Mayor

Date

Date

AI-8852

**New Business T.
Engineering**

City Council Special Meeting

Meeting Date: 12/15/2022

Disposal of Surplus Property - Engineering Division

Submitted By: Stephanie Wunderlich

Department: Engineering **Division:** Engineering

Council Committee Review?: Council **Date(s) of Committee Review:** 12/06/2022
Work
Session

Audio-Visual Needs: None **Emergency Legislation?:** No

**Motion/Ordinance/
Resolution No.:**

Agenda Item Description or Legislation Title

A Resolution Declaring Certain City Property As No Longer Required For Municipal Purposes As Surplus And Authorizing Disposal Of Said Property.
(first reading)

Purpose and Background

The following vehicles are no longer needed for municipal purposes by the Engineering Division and are ready for disposal through auction:

- (1) 2011 Ford F150 pickup truck, VIN #1FTFX1EF6BKD72118, Inventory Tag Number E-7
- (1) 2009 Chevy Impala VIN #2G1WS57M091298778

Fiscal Impact

Source of Funds: N/A

Cost: N/A

Recurring Cost? (Yes/No): N/A

Funds Available in Current Budget? (Yes/No): N/A

Financial Implications:

Attachments

Resolution

CITY OF HUBER HEIGHTS
STATE OF OHIO

RESOLUTION NO. 2022-R-

DECLARING CERTAIN CITY PROPERTY AS NO LONGER REQUIRED FOR MUNICIPAL PURPOSES AS SURPLUS AND AUTHORIZING DISPOSAL OF SAID PROPERTY.

WHEREAS, the City of Huber Heights is in possession of one (1) 2011 Ford F150 pickup truck, VIN #1FTFX1EF6BKD72118, Inventory Tag Number E-7 and one (1) 2009 Chevy Impala VIN #2G1WS57M091298778; and

WHEREAS, the property is no longer required for municipal purposes.

NOW, THEREFORE, BE IT RESOLVED by the City Council of Huber Heights, Ohio that:

Section 1. Consistent with provisions of the Ohio Revised Code, Section 721.15 and applicable City Codified Ordinances and purchasing procedures, the following equipment is declared surplus, no longer required for municipal purposes, and authorization is hereby provided to dispose of the property consistent with the provisions of the Huber Heights Codified Ordinances.

Item

2011 Ford F150	VIN #1FTFX1EF6BKD72118
2009 Chevy Impala	VIN #2G1WS57M091298778

Section 2. It is hereby found and determined that all formal actions of this Council concerning and relating to the passage of this Resolution were adopted in an open meeting of this Council and that all deliberations of this Council and of any of its Committees that resulted in such formal action were in meetings open to the public and in compliance with all legal requirements including Section 121.22 of the Ohio Revised Code.

Section 3. This Resolution shall go into effect upon its passage as provided by law and the Charter of the City of Huber Heights.

Passed by Council on the _____ day of _____, 2022;
_____ Yeas; _____ Nays.

Effective Date:

AUTHENTICATION:

Clerk of Council

Mayor

Date

Date