

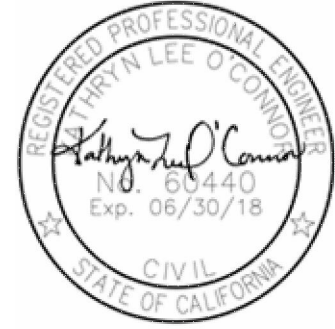

HUNSAKER & ASSOCIATES IRVINE, INC.



PLANNING
ENGINEERING
SURVEYING
GOVERNMENT RELATIONS

IRVINE
LOS ANGELES
PALM DESERT
RIVERSIDE
SAN DIEGO

Sewer System Hydraulic Analysis

Date: September 6, 2016

For: City of La Habra
Department of Public Works
Sewer and Water Division
La Habra, CA

By: Katie O'Connor, P.E.
Hunsaker & Associates Irvine, Inc.

Project: **Rancho La Habra Tentative Tract 17845**

Hunsaker & Associates Irvine, Inc. (H&A) is pleased to submit the Sewer System Hydraulic Analysis for Tract 17845. This analysis has been prepared to describe the proposed sewer system for the aforementioned residential development project in the City of La Habra. The project lies within the jurisdiction of the City of La Habra and the Orange County Sanitation District and their standards have been used for this report. Hydraulic models were prepared using Bentley Systems modeling software to model the peak flows the proposed sewer systems would experience.

THE PROPOSED SEWER COLLECTION SYSTEM FOR TRACT 17845 MEETS THE DESIGN STANDARDS SPECIFIED BY THE CITY OF LA HABRA AND THE ORANGE COUNTY SANITATION DISTRICT. Sewer design is based on the City of La Habra and Orange County Sanitation District requirements for capacity, depth of flow, and velocity. Slopes of proposed pipes will meet the minimum required slopes or follow proposed street grades. This evaluation is based on existing and known conditions and should be re-evaluated if these conditions change or new information becomes available. Any interpretation of the information presented in this report should be referred to H&A to ensure the integrity of the results.

Project Location

The Tentative Tract 17845 is located between Beach Boulevard and Idaho Street, south of Imperial Highway, in the City of La Habra. The proposed tract is located on the existing Westridge Golf Course. The general project location is shown on exhibit entitled, "Vicinity Map – Figure 1."

Summary of Findings

1. The development will include 7.3 acres of multifamily development, 20,000 square feet of retail development (or 49 multifamily units) on 2.4 acres, 51.8 acres of single family development, 89.1 acres of open space. 0.4 acres of recreation areas, and a community center to be located at the existing clubhouse. Existing Tract 15030 and Tract 15031 will join the proposed system and sewer service to the existing homes will not be interrupted.
2. The proposed project has four points of connection into existing sewer systems. The project will join existing OCSD sewer trunk lines in Beach Boulevard and Imperial Highway, as well as the City of La Habra sewer main in Idaho Street.



PRINCIPALS:

DAVID FRATTONE
FRED GRAYLEE
BRADLEY HAY
PAUL HUDDLESTON
KAMAL KARAM
DOUGLAS STALEY
KRIS WEBER
JOSEPH E. WIGHTMAN

FOUNDING PARTNERS:

RICHARD HUNSAKER
TOM R. MCGANNON
JOHN A. MICHLER
DOUGLAS G. SNYDER

Three Hughes
Irvine, California
92618-2021
(949) 583-1010 PH
(949) 583-0759 FX
www.hunsaker.com



There are two proposed connections to the existing line in Beach Boulevard. A proposed 8-inch sewer main will join the existing 39-inch trunk line near the intersection of Beach Boulevard and Hillsborough Park Apartment Homes (1501 Beach Blvd.) The second 8-inch sewer connection in Beach Boulevard will occur north of Hillsborough Park Apartment Homes and south of Westridge Plaza. The proposed connections will occur at existing manholes.

A proposed connection in Imperial Highway would be near the intersection of Imperial Highway and La Habra Hills Drive. The proposed 10-inch sewer main in La Habra Hills Drive would join a proposed manhole in the 36-inch OCSD trunk line. This proposed manhole will not be constructed within 200 feet of any existing manholes.

The proposed project would also join the existing 8-inch sewer line in Idaho Street, which is operated by the City of La Habra. This system joins the OCSD trunk line in Imperial Highway by routing through Rain Tree Drive, Lemon Tree Drive, Olive Tree Drive, and by traversing through a commercial lot on the north west end of Olive Tree Drive.

3. The proposed sewer system schematic is shown on the attached "Sewer System Model - Figure 2." The exhibit identifies points of sewer connection, sewer reaches, proposed and existing sewer mains.
4. Ruby Davila, OCSD Planning Division, has stated, via email (see attached), that there is sufficient capacity in the existing system for the proposed development. OCSD determined that the collection system has the capacity to accept flows from the proposed project by analyzing projected peak wet weather flows using a 10-year storm event, while also considering infiltration and inflow.
5. The proposed onsite sewer collection system consists of 8 and 10-inch diameter mains to be constructed at slopes of 0.40 percent or greater. Due to the preliminary design of the project, proposed street grades were used to approximate sewer main slopes and may need to be revised once a final design of the project is complete.
6. The total estimated sanitary sewer flows for the existing developments and the proposed Tract 17845 were based upon the Orange County Sanitation District design criteria. Orange County Sanitation District defines single family residential projects as low density developments. The sanitary sewer flows include the estimated existing and future wastewater flows from the drainage area based upon the proposed land uses.

Using the low density designation, the existing 8-inch pipes in Olive Tree Drive and in the commercial center between the west end of Olive Tree Drive and Imperial Highway have the highest percentage full once the proposed development is added. These two pipes are designated as pipes "A" and "B" in Figure 2. These existing pipes were constructed at a slope of 0.32% and will be 47% full during peak flow events once the proposed development is added into the system.

In areas with a limited number of homes (dead-end streets and cul de sacs) draining into the system, there may not be enough homes to generate the flow required to obtain a velocity of 2 feet per second. Sewer mains are by and large designed to follow street grades or minimum required slopes. It is



Sewer System Hydraulic Analysis, con't.
September 6, 2016
Page 3

generally understood that end of line runs would not produce flow velocities of 2 feet per second.

7. The sewer system for Tract 17845 was designed to meet all of the design criteria contained within the City of La Habra standards and the Orange County Sanitation District design criteria.
8. In order to calculate the pipe sizes and capacity of the proposed sewer system for Tract 17845, we have prepared a hydraulic model using Bentley FlowMaster V8i. The summary of outputs from the model runs is included in the Appendix of this report.

We sincerely trust these calculations will provide sufficient evidence that the proposed sewer system is adequate for the proposed Tract 17845. Please contact me at (949) 458-5437 or John Gass at 949-768-2579 if you have any questions.

KLO:tl
Enclosures
W.O. 0252-93X
(f:\wo\252\93X D01-klo.doc)
F:\0766\Engineering\SY_Sewer&WaterCalcs\SewerCalcs\SS_REPORT_letterhead_klo
stamped.doc

This page intentionally left blank.

PLOTTED BY: katieo DATE: Aug. 31, 2016 TIME: 12:21 PM F:\0766\Engineering\SY_Sewer & Water Calcs\Sewer Calcs\OVERALL_SS_EXHIBIT_1a habra hills dr connection.dwg

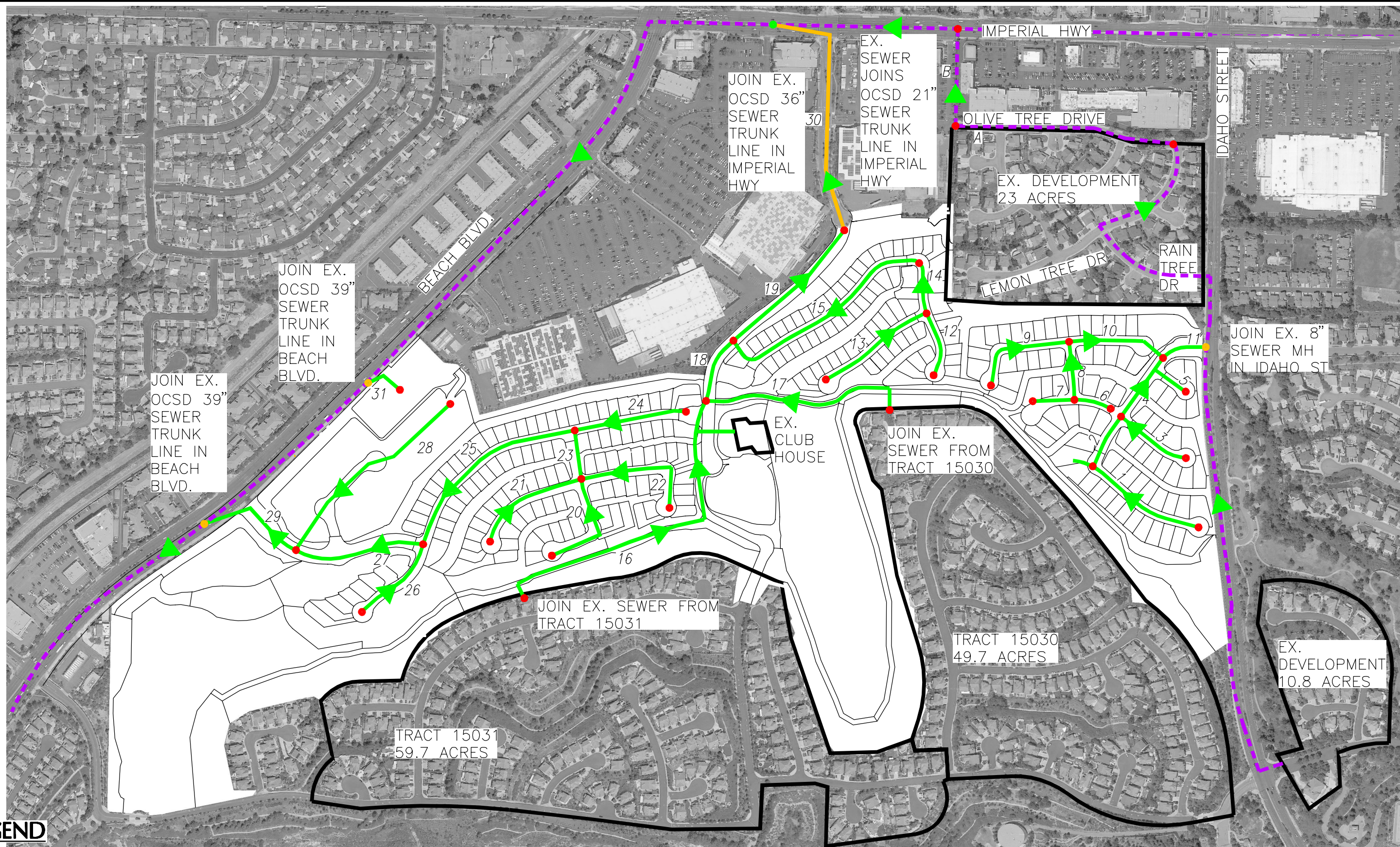

LEGEND

- FLOW ARROW
- EXISTING SEWER LINE
- PROPOSED 10" SEWER LINE & PIPE NUMBER
- PROPOSED 8" SEWER LINE & PIPE NUMBER
- REACH DIVIDING POINT
- NEW PROPOSED MANHOLE IN OCSD TRUNK LINE
- EXISTING MANHOLE TO JOIN

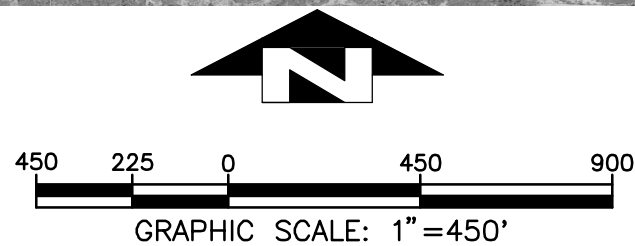

PREPARED BY:
HUNSAKER & ASSOCIATES
 IRVINE, INC.
 PLANNING ■ ENGINEERING ■ SURVEYING
 Three Hughes • Irvine, CA 92618 • PH: (949)583-1010 • FX: (949)583-0759

CITY OF LA HABRA
 TENTATIVE TRACT NO. 17845
ONSITE SEWER SYSTEM MODEL
 JOB NO. 0252-93X | DATE: 1 SEPT 2016

FIGURE
2

This page intentionally left blank.

TRACT 17845
SEWER DEMAND CALCULATIONS

ADD COEFF. (GPD/ACRE) PEAKING FACTOR 2.5
 LOW DENSITY 1488
 MED. DENSITY 3451
 HIGH DENSITY 7516

EAST SEWER DESIGN CALCULATIONS (JOIN IN IDAHO ST)

REACH	AREA (acres)	LAND USE DENSITY	AVG. DAILY FLOW COEFF. (GPD/acres)	AVERAGE DAILY FLOW (GPD)	AVERAGE DAILY FLOW (cfs)	PEAKING FACTOR	PEAK FLOW (cfs)	DIAMETER (inches)	SLOPE (ft/ft)
1	5.5	LOW DENSITY	1488	8184	0.01	2.5	0.03	8	0.01
2	5.5	LOW DENSITY	1488	8184	0.01	2.5	0.03	8	0.08
3	3.1	LOW DENSITY	1488	4613	0.01	2.5	0.02	8	0.01
4	8.6	LOW DENSITY	1488	12797	0.02	2.5	0.05	8	0.04
5	1.7	LOW DENSITY	1488	2530	0.00	2.5	0.01	8	0.04
6	1.5	LOW DENSITY	1488	2232	0.00	2.5	0.01	8	0.08
7	2	LOW DENSITY	1488	2976	0.00	2.5	0.01	8	0.01
8	3.5	LOW DENSITY	1488	5208	0.01	2.5	0.02	8	0.08
9	3.8	LOW DENSITY	1488	5654	0.01	2.5	0.02	8	0.01
10	10.1	LOW DENSITY	1488	15029	0.02	2.5	0.06	8	0.01
11 (JOIN IDAHO ST)	20.4	LOW DENSITY	1488	30355	0.05	2.5	0.12	8	0.004
8" SS IN RAIN TREE	31.2	LOW DENSITY	1488	46426	0.07	2.5	0.18	8	0.01
8" SS JOINS IMPERIAL TRUNK LINE	54.2	LOW DENSITY	1488	80650	0.13	2.5	0.31	8	0.0032

SMALL LOT/TREVINO AREA SEWER DESIGN CALCULATIONS (JOIN IN IMPERIAL HWY & BEACH)

REACH	AREA (acres)	LAND USE DENSITY	AVG. DAILY FLOW COEFF. (GPD/acres)	TOTAL AVERAGE DAILY FLOW (GPD)	AVERAGE DAILY FLOW (cfs)	PEAKING FACTOR	PEAK FLOW (cfs)	DIAMETER (inches)	SLOPE (ft/ft)
12	1.7	LOW DENSITY	1488	2530	0.00	2.5	0.01	8	0.1
13	3	LOW DENSITY	1488	4464	0.01	2.5	0.02	8	0.01
14	5.6	LOW DENSITY	1488	8785	0.01	2.5	0.03	8	0.05
	0.2	COMMERCIAL	2262						
15 (JOIN IN TREVINO)	11.2	LOW DENSITY	1488	17118	0.03	2.5	0.07	8	0.01
	0.2	COMMERCIAL	2262						
16 (TR15031)	59.7	LOW DENSITY	1488	88834	0.14	2.5	0.34	8	0.005
17 (TR 15030)	49.7	LOW DENSITY	1488	73954	0.11	2.5	0.29	8	0.01
18	109.4	LOW DENSITY	1488	163918	0.25	2.5	0.64	8	0.04
	0.5	COMMERCIAL	2262						
19	120.6	LOW DENSITY	1488	181036	0.28	2.5	0.70	8	0.06
	0.7	COMMERCIAL	2262						
20	1.8	LOW DENSITY	1488	2678	0.004	2.5	0.01	8	0.03
21	4	LOW DENSITY	1488	5952	0.01	2.5	0.02	8	0.01
22	3.4	LOW DENSITY	1488	5059	0.01	2.5	0.02	8	0.02
23	9.2	LOW DENSITY	1488	13690	0.02	2.5	0.05	8	0.05
24	3	LOW DENSITY	1488	4464	0.01	2.5	0.02	8	0.03
25	12.2	LOW DENSITY	1488	18606	0.03	2.5	0.07	8	0.01
	0.2	COMMERCIAL	2262						
26	2.3	LOW DENSITY	1488	3422	0.01	2.5	0.01	8	0.10
27	14.5	LOW DENSITY	1488	22028	0.03	2.5	0.09	8	0.05
	0.2	COMMERCIAL	2262						
28	7.3	HIGH DENSITY	7516	54867	0.09	2.5	0.21	8	0.01
29 (JOIN IN BEACH)	14.5	LOW DENSITY	1488	76895	0.12	2.5	0.30	8	0.02
	7.3	HIGH DENSITY	7516						
	0.2	COMMERCIAL	2262						
30 (JOIN IN IMPERIAL HWY)	120.6	LOW DENSITY	1488	181036	0.28	2.5	0.70	10	0.005
	0.7	COMMERCIAL	2262						
31 (JOIN IN BEACH)	2.4	COMMERCIAL OR HIGH DENSITY	7516	18038	0.03	2.5	0.07	8	0.01

EXISTING SEWER FLOW CALCULATIONS

TRACT	AREA (acres)	LAND DENSITY	AVG. DAILY FLOW COEFF. (GPD/acres)	AVERAGE DAILY FLOW (GPD)	AVERAGE DAILY FLOW (cfs)	PEAKING FACTOR	PEAK FLOW (cfs)
15030	49.7	LOW DENSITY	1488	73954	0.11	2.5	0.29
15031	59.7	LOW DENSITY	1488	88834	0.14	2.5	0.34
CLUB HOUSE	0.5	COMMERCIAL	2262	1131	0.002	2.5	0.004
EAST OF IDAHO ST	10.8	LOW DENSITY	1488	16070	0.02	2.5	0.06

WESTRIDGE – Tract 17845

Proposed Onsite Sewer System

FlowMaster Calculations

Project Description

Worksheet: Circular Pipe - 1
 Flow Element: Circular Pipe
 Friction Method: Manning Formula
 Solve For: Normal Depth

Input Data

Roughness Coefficient 0.013
 Channel Slope 0.0100 ft/ft
 Diameter 8 in
 Discharge 0.0300 ft³/s

Results

Normal Depth 0.87 in
 Flow Area 0.02 ft²
 Wetted Perimeter 0.45 ft
 Top Width 0.41 ft
 Critical Depth 0.08 ft
 Percent Full 10.90 %
 Critical Slope 0.00740 ft/ft
 Velocity 1.46 ft/s
 Velocity Head 0.03 ft
 Specific Energy 0.11 ft
 Froude Number 1.16
 Maximum Discharge 1.30 ft³/s
 Discharge Full 1.21 ft³/s
 Slope Full 0.00001 ft/ft
 Flow Type SuperCritical

Project Description

Worksheet: Circular Pipe - 2
 Flow Element: Circular Pipe
 Friction Method: Manning Formula
 Solve For: Normal Depth

Input Data

Roughness Coefficient 0.013
 Channel Slope 0.0800 ft/ft
 Diameter 8 in
 Discharge 0.0300 ft³/s

Results

Normal Depth 0.53 in
 Flow Area 0.01 ft²
 Wetted Perimeter 0.35 ft
 Top Width 0.33 ft
 Critical Depth 0.08 ft
 Percent Full 6.70 %
 Critical Slope 0.00728 ft/ft
 Velocity 3.00 ft/s
 Velocity Head 0.14 ft
 Specific Energy 0.18 ft
 Froude Number 3.05
 Maximum Discharge 3.68 ft³/s
 Discharge Full 3.42 ft³/s
 Slope Full 0.00001 ft/ft
 Flow Type SuperCritical

WESTRIDGE – Tract 17845

Proposed Onsite Sewer System

FlowMaster Calculations

Project Description	
Worksheet:	Circular Pipe - 3
Flow Element:	Circular Pipe
Friction Method:	Manning Formula
Solve For:	Normal Depth

Input Data	
Roughness Coefficient	0.013
Channel Slope	0.0100 ft/ft
Diameter	8 in
Discharge	0.0200 ft ³ /s

Results	
Normal Depth	0.72 in
Flow Area	0.02 ft ²
Wetted Perimeter	0.41 ft
Top Width	0.38 ft
Critical Depth	0.06 ft
Percent Full	9.00 %
Critical Slope	0.00765 ft/ft
Velocity	1.30 ft/s
Velocity Head	0.03 ft
Specific Energy	0.09 ft
Froude Number	1.13
Maximum Discharge	1.30 ft ³ /s
Discharge Full	1.21 ft ³ /s
Slope Full	0.00000 ft/ft
Flow Type	SuperCritical

Project Description	
Worksheet:	Circular Pipe - 4
Flow Element:	Circular Pipe
Friction Method:	Manning Formula
Solve For:	Normal Depth

Input Data	
Roughness Coefficient	0.013
Channel Slope	0.0400 ft/ft
Diameter	8 in
Discharge	0.0500 ft ³ /s

Results	
Normal Depth	0.80 in
Flow Area	0.02 ft ²
Wetted Perimeter	0.43 ft
Top Width	0.40 ft
Critical Depth	0.10 ft
Percent Full	10.00 %
Critical Slope	0.00694 ft/ft
Velocity	2.77 ft/s
Velocity Head	0.12 ft
Specific Energy	0.19 ft
Froude Number	2.30
Maximum Discharge	2.60 ft ³ /s
Discharge Full	2.42 ft ³ /s
Slope Full	0.00002 ft/ft
Flow Type	SuperCritical

WESTRIDGE – Tract 17845

Proposed Onsite Sewer System

FlowMaster Calculations

Project Description	
Worksheet:	Circular Pipe - 5
Flow Element:	Circular Pipe
Friction Method:	Manning Formula
Solve For:	Normal Depth

Input Data	
Roughness Coefficient	0.013
Channel Slope	0.0400 ft/ft
Diameter	8 in
Discharge	0.0100 ft ³ /s

Results	
Normal Depth	0.38 in
Flow Area	0.01 ft ²
Wetted Perimeter	0.29 ft
Top Width	0.28 ft
Critical Depth	0.04 ft
Percent Full	4.70 %
Critical Slope	0.00828 ft/ft
Velocity	1.69 ft/s
Velocity Head	0.04 ft
Specific Energy	0.08 ft
Froude Number	2.05
Maximum Discharge	2.60 ft ³ /s
Discharge Full	2.42 ft ³ /s
Slope Full	0.00000 ft/ft
Flow Type	SuperCritical

Project Description	
Worksheet:	Circular Pipe - 6
Flow Element:	Circular Pipe
Friction Method:	Manning Formula
Solve For:	Normal Depth

Input Data	
Roughness Coefficient	0.013
Channel Slope	0.0800 ft/ft
Diameter	8 in
Discharge	0.0100 ft ³ /s

Results	
Normal Depth	0.32 in
Flow Area	0.00 ft ²
Wetted Perimeter	0.27 ft
Top Width	0.26 ft
Critical Depth	0.04 ft
Percent Full	4.00 %
Critical Slope	0.00830 ft/ft
Velocity	2.16 ft/s
Velocity Head	0.07 ft
Specific Energy	0.10 ft
Froude Number	2.85
Maximum Discharge	3.68 ft ³ /s
Discharge Full	3.42 ft ³ /s
Slope Full	0.00000 ft/ft
Flow Type	SuperCritical

WESTRIDGE – Tract 17845

Proposed Onsite Sewer System

FlowMaster Calculations

Project Description	
Worksheet:	Circular Pipe - 7
Flow Element:	Circular Pipe
Friction Method:	Manning Formula
Solve For:	Normal Depth

Input Data	
Roughness Coefficient	0.013
Channel Slope	0.0100 ft/ft
Diameter	8 in
Discharge	0.0100 ft ³ /s

Results	
Normal Depth	0.52 in
Flow Area	0.01 ft ²
Wetted Perimeter	0.34 ft
Top Width	0.33 ft
Critical Depth	0.04 ft
Percent Full	6.50 %
Critical Slope	0.00848 ft/ft
Velocity	1.04 ft/s
Velocity Head	0.02 ft
Specific Energy	0.06 ft
Froude Number	1.08
Maximum Discharge	1.30 ft ³ /s
Discharge Full	1.21 ft ³ /s
Slope Full	0.00000 ft/ft
Flow Type	SuperCritical

Project Description	
Worksheet:	Circular Pipe - 8
Flow Element:	Circular Pipe
Friction Method:	Manning Formula
Solve For:	Normal Depth

Input Data	
Roughness Coefficient	0.013
Channel Slope	0.0800 ft/ft
Diameter	8 in
Discharge	0.0200 ft ³ /s

Results	
Normal Depth	0.44 in
Flow Area	0.01 ft ²
Wetted Perimeter	0.32 ft
Top Width	0.30 ft
Critical Depth	0.06 ft
Percent Full	5.50 %
Critical Slope	0.00769 ft/ft
Velocity	2.66 ft/s
Velocity Head	0.11 ft
Specific Energy	0.15 ft
Froude Number	2.99
Maximum Discharge	3.68 ft ³ /s
Discharge Full	3.42 ft ³ /s
Slope Full	0.00000 ft/ft
Flow Type	SuperCritical

WESTRIDGE – Tract 17845

Proposed Onsite Sewer System

FlowMaster Calculations

Project Description	
Worksheet:	Circular Pipe - 9
Flow Element:	Circular Pipe
Friction Method:	Manning Formula
Solve For:	Normal Depth

Input Data	
Roughness Coefficient	0.013
Channel Slope	0.0100 ft/ft
Diameter	8 in
Discharge	0.0200 ft ³ /s

Results	
Normal Depth	0.72 in
Flow Area	0.02 ft ²
Wetted Perimeter	0.41 ft
Top Width	0.38 ft
Critical Depth	0.06 ft
Percent Full	9.00 %
Critical Slope	0.00765 ft/ft
Velocity	1.30 ft/s
Velocity Head	0.03 ft
Specific Energy	0.09 ft
Froude Number	1.13
Maximum Discharge	1.30 ft ³ /s
Discharge Full	1.21 ft ³ /s
Slope Full	0.00000 ft/ft
Flow Type	SuperCritical

Project Description	
Worksheet:	Circular Pipe - 10
Flow Element:	Circular Pipe
Friction Method:	Manning Formula
Solve For:	Normal Depth

Input Data	
Roughness Coefficient	0.013
Channel Slope	0.0100 ft/ft
Diameter	8 in
Discharge	0.0600 ft ³ /s

Results	
Normal Depth	1.21 in
Flow Area	0.03 ft ²
Wetted Perimeter	0.53 ft
Top Width	0.48 ft
Critical Depth	0.11 ft
Percent Full	15.20 %
Critical Slope	0.00680 ft/ft
Velocity	1.80 ft/s
Velocity Head	0.05 ft
Specific Energy	0.15 ft
Froude Number	1.20
Maximum Discharge	1.30 ft ³ /s
Discharge Full	1.21 ft ³ /s
Slope Full	0.00002 ft/ft
Flow Type	SuperCritical

WESTRIDGE – Tract 17845

Proposed Onsite Sewer System

FlowMaster Calculations

Project Description	
Worksheet:	Circular Pipe - 11
Flow Element:	Circular Pipe
Friction Method:	Manning Formula
Solve For:	Normal Depth

Input Data	
Roughness Coefficient	0.013
Channel Slope	0.0040 ft/ft
Diameter	8 in
Discharge	0.1200 ft ³ /s

Results	
Normal Depth	2.14 in
Flow Area	0.08 ft ²
Wetted Perimeter	0.73 ft
Top Width	0.59 ft
Critical Depth	0.16 ft
Percent Full	26.80 %
Critical Slope	0.00652 ft/ft
Velocity	1.60 ft/s
Velocity Head	0.04 ft
Specific Energy	0.22 ft
Froude Number	0.79
Maximum Discharge	0.82 ft ³ /s
Discharge Full	0.76 ft ³ /s
Slope Full	0.00010 ft/ft
Flow Type	SubCritical

Project Description	
Worksheet:	Circular Pipe - 12
Flow Element:	Circular Pipe
Friction Method:	Manning Formula
Solve For:	Normal Depth

Input Data	
Roughness Coefficient	0.013
Channel Slope	0.1000 ft/ft
Diameter	8 in
Discharge	0.0100 ft ³ /s

Results	
Normal Depth	0.30 in
Flow Area	0.00 ft ²
Wetted Perimeter	0.26 ft
Top Width	0.25 ft
Critical Depth	0.04 ft
Percent Full	3.80 %
Critical Slope	0.00833 ft/ft
Velocity	2.33 ft/s
Velocity Head	0.08 ft
Specific Energy	0.11 ft
Froude Number	3.17
Maximum Discharge	4.11 ft ³ /s
Discharge Full	3.82 ft ³ /s
Slope Full	0.00000 ft/ft
Flow Type	SuperCritical

WESTRIDGE – Tract 17845

Proposed Onsite Sewer System

FlowMaster Calculations

Project Description	
Worksheet:	Circular Pipe - 13
Flow Element:	Circular Pipe
Friction Method:	Manning Formula
Solve For:	Normal Depth

Input Data	
Roughness Coefficient	0.013
Channel Slope	0.0100 ft/ft
Diameter	8 in
Discharge	0.0200 ft ³ /s

Results	
Normal Depth	0.72 in
Flow Area	0.02 ft ²
Wetted Perimeter	0.41 ft
Top Width	0.38 ft
Critical Depth	0.06 ft
Percent Full	9.00 %
Critical Slope	0.00765 ft/ft
Velocity	1.30 ft/s
Velocity Head	0.03 ft
Specific Energy	0.09 ft
Froude Number	1.13
Maximum Discharge	1.30 ft ³ /s
Discharge Full	1.21 ft ³ /s
Slope Full	0.00000 ft/ft
Flow Type	SuperCritical

Project Description	
Worksheet:	Circular Pipe - 14
Flow Element:	Circular Pipe
Friction Method:	Manning Formula
Solve For:	Normal Depth

Input Data	
Roughness Coefficient	0.013
Channel Slope	0.0500 ft/ft
Diameter	8 in
Discharge	0.0300 ft ³ /s

Results	
Normal Depth	0.60 in
Flow Area	0.01 ft ²
Wetted Perimeter	0.37 ft
Top Width	0.35 ft
Critical Depth	0.08 ft
Percent Full	7.40 %
Critical Slope	0.00729 ft/ft
Velocity	2.55 ft/s
Velocity Head	0.10 ft
Specific Energy	0.15 ft
Froude Number	2.45
Maximum Discharge	2.91 ft ³ /s
Discharge Full	2.70 ft ³ /s
Slope Full	0.00001 ft/ft
Flow Type	SuperCritical

WESTRIDGE – Tract 17845

Proposed Onsite Sewer System

FlowMaster Calculations

Project Description	
Worksheet:	Circular Pipe - 15
Flow Element:	Circular Pipe
Friction Method:	Manning Formula
Solve For:	Normal Depth

Input Data	
Roughness Coefficient	0.013
Channel Slope	0.0100 ft/ft
Diameter	8 in
Discharge	0.0700 ft ³ /s

Results	
Normal Depth	1.31 in
Flow Area	0.04 ft ²
Wetted Perimeter	0.55 ft
Top Width	0.49 ft
Critical Depth	0.12 ft
Percent Full	16.30 %
Critical Slope	0.00682 ft/ft
Velocity	1.88 ft/s
Velocity Head	0.06 ft
Specific Energy	0.16 ft
Froude Number	1.21
Maximum Discharge	1.30 ft ³ /s
Discharge Full	1.21 ft ³ /s
Slope Full	0.00003 ft/ft
Flow Type	SuperCritical

Project Description	
Worksheet:	Circular Pipe - 16
Flow Element:	Circular Pipe
Friction Method:	Manning Formula
Solve For:	Normal Depth

Input Data	
Roughness Coefficient	0.013
Channel Slope	0.0050 ft/ft
Diameter	8 in
Discharge	0.3400 ft ³ /s

Results	
Normal Depth	3.51 in
Flow Area	0.15 ft ²
Wetted Perimeter	0.96 ft
Top Width	0.66 ft
Critical Depth	0.27 ft
Percent Full	43.80 %
Critical Slope	0.00660 ft/ft
Velocity	2.31 ft/s
Velocity Head	0.08 ft
Specific Energy	0.38 ft
Froude Number	0.86
Maximum Discharge	0.92 ft ³ /s
Discharge Full	0.85 ft ³ /s
Slope Full	0.00079 ft/ft
Flow Type	SubCritical

WESTRIDGE – Tract 17845

Proposed Onsite Sewer System

FlowMaster Calculations

Project Description	
Worksheet:	Circular Pipe - 17
Flow Element:	Circular Pipe
Friction Method:	Manning Formula
Solve For:	Normal Depth

Input Data	
Roughness Coefficient	0.013
Channel Slope	0.0240 ft/ft
Diameter	8 in
Discharge	0.2900 ft ³ /s

Results	
Normal Depth	2.13 in
Flow Area	0.07 ft ²
Wetted Perimeter	0.72 ft
Top Width	0.59 ft
Critical Depth	0.25 ft
Percent Full	26.60 %
Critical Slope	0.00651 ft/ft
Velocity	3.89 ft/s
Velocity Head	0.24 ft
Specific Energy	0.41 ft
Froude Number	1.93
Maximum Discharge	2.01 ft ³ /s
Discharge Full	1.87 ft ³ /s
Slope Full	0.00058 ft/ft
Flow Type	SuperCritical

Project Description	
Worksheet:	Circular Pipe - 18
Flow Element:	Circular Pipe
Friction Method:	Manning Formula
Solve For:	Normal Depth

Input Data	
Roughness Coefficient	0.013
Channel Slope	0.0400 ft/ft
Diameter	8 in
Discharge	0.6400 ft ³ /s

Results	
Normal Depth	2.81 in
Flow Area	0.11 ft ²
Wetted Perimeter	0.85 ft
Top Width	0.64 ft
Critical Depth	0.38 ft
Percent Full	35.20 %
Critical Slope	0.00749 ft/ft
Velocity	5.84 ft/s
Velocity Head	0.53 ft
Specific Energy	0.76 ft
Froude Number	2.48
Maximum Discharge	2.60 ft ³ /s
Discharge Full	2.42 ft ³ /s
Slope Full	0.00281 ft/ft
Flow Type	SuperCritical

WESTRIDGE – Tract 17845

Proposed Onsite Sewer System

FlowMaster Calculations

Project Description	
Worksheet:	Circular Pipe - 19
Flow Element:	Circular Pipe
Friction Method:	Manning Formula
Solve For:	Normal Depth

Input Data	
Roughness Coefficient	0.013
Channel Slope	0.0600 ft/ft
Diameter	8 in
Discharge	0.7000 ft ³ /s

Results	
Normal Depth	2.65 in
Flow Area	0.10 ft ²
Wetted Perimeter	0.82 ft
Top Width	0.63 ft
Critical Depth	0.39 ft
Percent Full	33.10 %
Critical Slope	0.00773 ft/ft
Velocity	6.94 ft/s
Velocity Head	0.75 ft
Specific Energy	0.97 ft
Froude Number	3.05
Maximum Discharge	3.18 ft ³ /s
Discharge Full	2.96 ft ³ /s
Slope Full	0.00336 ft/ft
Flow Type	SuperCritical

Project Description	
Worksheet:	Circular Pipe - 20
Flow Element:	Circular Pipe
Friction Method:	Manning Formula
Solve For:	Normal Depth

Input Data	
Roughness Coefficient	0.013
Channel Slope	0.0300 ft/ft
Diameter	8 in
Discharge	0.0100 ft ³ /s

Results	
Normal Depth	0.40 in
Flow Area	0.01 ft ²
Wetted Perimeter	0.30 ft
Top Width	0.29 ft
Critical Depth	0.05 ft
Percent Full	5.00 %
Critical Slope	0.00820 ft/ft
Velocity	1.54 ft/s
Velocity Head	0.04 ft
Specific Energy	0.07 ft
Froude Number	1.81
Maximum Discharge	2.25 ft ³ /s
Discharge Full	2.09 ft ³ /s
Slope Full	0.00000 ft/ft
Flow Type	SuperCritical

WESTRIDGE – Tract 17845

Proposed Onsite Sewer System

FlowMaster Calculations

Project Description	
Worksheet:	Circular Pipe - 21
Flow Element:	Circular Pipe
Friction Method:	Manning Formula
Solve For:	Normal Depth

Input Data	
Roughness Coefficient	0.013
Channel Slope	0.0100 ft/ft
Diameter	8 in
Discharge	0.0200 ft ³ /s

Results	
Normal Depth	0.72 in
Flow Area	0.02 ft ²
Wetted Perimeter	0.41 ft
Top Width	0.38 ft
Critical Depth	0.06 ft
Percent Full	9.00 %
Critical Slope	0.00765 ft/ft
Velocity	1.30 ft/s
Velocity Head	0.03 ft
Specific Energy	0.09 ft
Froude Number	1.13
Maximum Discharge	1.30 ft ³ /s
Discharge Full	1.21 ft ³ /s
Slope Full	0.00000 ft/ft
Flow Type	SuperCritical

Project Description	
Worksheet:	Circular Pipe - 22
Flow Element:	Circular Pipe
Friction Method:	Manning Formula
Solve For:	Normal Depth

Input Data	
Roughness Coefficient	0.013
Channel Slope	0.0200 ft/ft
Diameter	8 in
Discharge	0.0200 ft ³ /s

Results	
Normal Depth	0.61 in
Flow Area	0.01 ft ²
Wetted Perimeter	0.37 ft
Top Width	0.35 ft
Critical Depth	0.06 ft
Percent Full	7.60 %
Critical Slope	0.00763 ft/ft
Velocity	1.64 ft/s
Velocity Head	0.04 ft
Specific Energy	0.09 ft
Froude Number	1.56
Maximum Discharge	1.84 ft ³ /s
Discharge Full	1.71 ft ³ /s
Slope Full	0.00000 ft/ft
Flow Type	SuperCritical

WESTRIDGE – Tract 17845

Proposed Onsite Sewer System

FlowMaster Calculations

Project Description	
Worksheet:	Circular Pipe - 23
Flow Element:	Circular Pipe
Friction Method:	Manning Formula
Solve For:	Normal Depth

Input Data	
Roughness Coefficient	0.013
Channel Slope	0.0500 ft/ft
Diameter	8 in
Discharge	0.0500 ft ³ /s

Results	
Normal Depth	0.76 in
Flow Area	0.02 ft ²
Wetted Perimeter	0.42 ft
Top Width	0.39 ft
Critical Depth	0.10 ft
Percent Full	9.50 %
Critical Slope	0.00690 ft/ft
Velocity	2.99 ft/s
Velocity Head	0.14 ft
Specific Energy	0.20 ft
Froude Number	2.54
Maximum Discharge	2.91 ft ³ /s
Discharge Full	2.70 ft ³ /s
Slope Full	0.00002 ft/ft
Flow Type	SuperCritical

Project Description	
Worksheet:	Circular Pipe - 24
Flow Element:	Circular Pipe
Friction Method:	Manning Formula
Solve For:	Normal Depth

Input Data	
Roughness Coefficient	0.013
Channel Slope	0.0300 ft/ft
Diameter	8 in
Discharge	0.0200 ft ³ /s

Results	
Normal Depth	0.56 in
Flow Area	0.01 ft ²
Wetted Perimeter	0.36 ft
Top Width	0.34 ft
Critical Depth	0.06 ft
Percent Full	6.90 %
Critical Slope	0.00763 ft/ft
Velocity	1.89 ft/s
Velocity Head	0.06 ft
Specific Energy	0.10 ft
Froude Number	1.88
Maximum Discharge	2.25 ft ³ /s
Discharge Full	2.09 ft ³ /s
Slope Full	0.00000 ft/ft
Flow Type	SuperCritical

WESTRIDGE – Tract 17845

Proposed Onsite Sewer System

FlowMaster Calculations

Project Description	
Worksheet:	Circular Pipe - 25
Flow Element:	Circular Pipe
Friction Method:	Manning Formula
Solve For:	Normal Depth

Input Data	
Roughness Coefficient	0.013
Channel Slope	0.0100 ft/ft
Diameter	8 in
Discharge	0.0700 ft ³ /s

Results	
Normal Depth	1.31 in
Flow Area	0.04 ft ²
Wetted Perimeter	0.55 ft
Top Width	0.49 ft
Critical Depth	0.12 ft
Percent Full	16.30 %
Critical Slope	0.00682 ft/ft
Velocity	1.88 ft/s
Velocity Head	0.06 ft
Specific Energy	0.16 ft
Froude Number	1.21
Maximum Discharge	1.30 ft ³ /s
Discharge Full	1.21 ft ³ /s
Slope Full	0.00003 ft/ft
Flow Type	SuperCritical

Project Description	
Worksheet:	Circular Pipe - 26
Flow Element:	Circular Pipe
Friction Method:	Manning Formula
Solve For:	Normal Depth

Input Data	
Roughness Coefficient	0.013
Channel Slope	0.1000 ft/ft
Diameter	8 in
Discharge	0.0100 ft ³ /s

Results	
Normal Depth	0.30 in
Flow Area	0.00 ft ²
Wetted Perimeter	0.26 ft
Top Width	0.25 ft
Critical Depth	0.04 ft
Percent Full	3.80 %
Critical Slope	0.00833 ft/ft
Velocity	2.33 ft/s
Velocity Head	0.08 ft
Specific Energy	0.11 ft
Froude Number	3.17
Maximum Discharge	4.11 ft ³ /s
Discharge Full	3.82 ft ³ /s
Slope Full	0.00000 ft/ft
Flow Type	SuperCritical

WESTRIDGE – Tract 17845

Proposed Onsite Sewer System

FlowMaster Calculations

Project Description

Worksheet: Circular Pipe - 27
 Flow Element: Circular Pipe
 Friction Method: Manning Formula
 Solve For: Normal Depth

Input Data

Roughness Coefficient 0.013
 Channel Slope 0.0500 ft/ft
 Diameter 8 in
 Discharge 0.0900 ft³/s

Results

Normal Depth 1.00 in
 Flow Area 0.03 ft²
 Wetted Perimeter 0.48 ft
 Top Width 0.44 ft
 Critical Depth 0.14 ft
 Percent Full 12.50 %
 Critical Slope 0.00658 ft/ft
 Velocity 3.58 ft/s
 Velocity Head 0.20 ft
 Specific Energy 0.28 ft
 Froude Number 2.64
 Maximum Discharge 2.91 ft³/s
 Discharge Full 2.70 ft³/s
 Slope Full 0.00006 ft/ft
 Flow Type SuperCritical

Project Description

Worksheet: Circular Pipe - 28
 Flow Element: Circular Pipe
 Friction Method: Manning Formula
 Solve For: Normal Depth

Input Data

Roughness Coefficient 0.013
 Channel Slope 0.0100 ft/ft
 Diameter 8 in
 Discharge 0.2100 ft³/s

Results

Normal Depth 2.26 in
 Flow Area 0.08 ft²
 Wetted Perimeter 0.75 ft
 Top Width 0.60 ft
 Critical Depth 0.21 ft
 Percent Full 28.20 %
 Critical Slope 0.00646 ft/ft
 Velocity 2.60 ft/s
 Velocity Head 0.10 ft
 Specific Energy 0.29 ft
 Froude Number 1.25
 Maximum Discharge 1.30 ft³/s
 Discharge Full 1.21 ft³/s
 Slope Full 0.00030 ft/ft
 Flow Type SuperCritical

WESTRIDGE – Tract 17845

Proposed Onsite Sewer System

FlowMaster Calculations

Project Description

Worksheet: Circular Pipe - 29
 Flow Element: Circular Pipe
 Friction Method: Manning Formula
 Solve For: Normal Depth

Input Data

Roughness Coefficient 0.013
 Channel Slope 0.0100 ft/ft
 Diameter 8 in
 Discharge 0.3000 ft³/s

Results

Normal Depth 2.72 in
 Flow Area 0.10 ft²
 Wetted Perimeter 0.83 ft
 Top Width 0.63 ft
 Critical Depth 0.25 ft
 Percent Full 34.0 %
 Critical Slope 0.00653 ft/ft
 Velocity 2.87 ft/s
 Velocity Head 0.13 ft
 Specific Energy 0.35 ft
 Froude Number 1.24
 Maximum Discharge 1.30 ft³/s
 Discharge Full 1.21 ft³/s
 Slope Full 0.00062 ft/ft
 Flow Type SuperCritical

Project Description

Worksheet: Circular Pipe - 30
 Flow Element: Circular Pipe
 Friction Method: Manning Formula
 Solve For: Normal Depth

Input Data

Roughness Coefficient 0.013
 Channel Slope 0.0050 ft/ft
 Diameter 10 in
 Discharge 0.7000 ft³/s

Results

Normal Depth 4.71 in
 Flow Area 0.25 ft²
 Wetted Perimeter 1.26 ft
 Top Width 0.83 ft
 Critical Depth 0.37 ft
 Percent Full 47.10 %
 Critical Slope 0.00626 ft/ft
 Velocity 2.77 ft/s
 Velocity Head 0.12 ft
 Specific Energy 0.51 ft
 Froude Number 0.89
 Maximum Discharge 1.67 ft³/s
 Discharge Full 1.55 ft³/s
 Slope Full 0.00102 ft/ft
 Flow Type SubCritical

WESTRIDGE – Tract 17845

Proposed Onsite Sewer System

FlowMaster Calculations

Project Description

Worksheet:	Circular Pipe - 31
Flow Element:	Circular Pipe
Friction Method:	Manning Formula
Solve For:	Normal Depth

Input Data

Roughness Coefficient	0.013
Channel Slope	0.0100 ft/ft
Diameter	8 in
Discharge	0.0700 cfs

Results

Normal Depth	1.31 in
Flow Area	0.04 ft ²
Wetted Perimeter	0.55 ft
Top Width	0.49 ft
Critical Depth	0.12 ft
Percent Full	16.3%
Critical Slope	0.00682 ft/ft
Velocity	1.88 ft/s
Velocity Head	0.06 ft
Specific Energy	0.16 ft
Froude Number	1.21
Maximum Discharge	1.30 cfs
Discharge Full	1.21 cfs
Slope Full	0.00003 ft/ft
Flow Type	SuperCritical

WESTRIDGE – Tract 17845

Proposed Onsite Sewer System

FlowMaster Calculations

Project Description

Worksheet: EXISTING 8"
OLIVE TREE/
JOINS IMP HWY

Flow Element: Circular Pipe

Friction Method: Manning Formula

Solve For: Normal Depth

Input Data

Roughness Coefficient 0.013

Channel Slope 0.0032 ft/ft

Diameter 8 in

Discharge 0.3100 ft³/s

Results

Normal Depth 3.78 in

Flow Area 0.16 ft²

Wetted Perimeter 1.01 ft

Top Width 0.67 ft

Critical Depth 0.26 ft

Percent Full 47.20 %

Critical Slope 0.00655 ft/ft

Velocity 1.91 ft/s

Velocity Head 0.06 ft

Specific Energy 0.37 ft

Froude Number 0.68

Maximum Discharge 0.74 ft³/s

Discharge Full 0.68 ft³/s

Slope Full 0.00066 ft/ft

Flow Type SubCritical

Project Description

Worksheet: EXISTING 8" IN
RAIN TREE

Flow Element: Circular Pipe

Friction Method: Manning Formula

Solve For: Normal Depth

Input Data

Roughness Coefficient 0.013

Channel Slope 0.0100 ft/ft

Diameter 8 in

Discharge 0.1800 ft³/s

Results

Normal Depth 2.09 in

Flow Area 0.07 ft²

Wetted Perimeter 0.71 ft

Top Width 0.59 ft

Critical Depth 0.19 ft

Percent Full 26.10 %

Critical Slope 0.00644 ft/ft

Velocity 2.49 ft/s

Velocity Head 0.10 ft

Specific Energy 0.27 ft

Froude Number 1.25

Maximum Discharge 1.30 ft³/s

Discharge Full 1.21 ft³/s

Slope Full 0.00022 ft/ft

Flow Type SuperCritical

Katie OConnor

From: Davila, Rudy <RDavila@OCSD.COM>
Sent: Monday, January 04, 2016 11:23 AM
To: Katie OConnor
Cc: Davila, Rudy
Subject: RE: Tract 17845 Sewer System Hydraulic Analysis : submitted July 30, 2015
Attachments: Design and Construction Reqts For Sanitary Sewers -2014 Nov.pdf; Fees 2015-16.pdf

Katie

The Orange County Sanitation District (OCSD) has reviewed your Sewer System Hydraulic Analysis and follow up email to determine if OCSD has capacity for your project's projected peak flow contribution to the OCSD collection system. To make this determination, we looked at a peak wet weather scenario using a 10-year storm event and also considered infiltration and inflow. It was determined the OCSD collection system has the capacity to receive your project's flows however modifications may need to be planned for the proposed points of connection; refer to images below.

Tract 17845 Reach 29:



NEW CONNECTIONS WITHIN TWO HUNDRED FEET OF AN EXISTING OCSD MH MUST CONNECT TO SAME OCSD MH.

REACH 29

Tract 17845 Reach 30:



A trunk connection permit is required for direct connections to OCSD trunk manholes; connections to OCSD regional sewers are only permitted through manholes. Please submit plans to me for review/comments/approval. Note that no new connections are permitted within two hundred feet of an existing OCSD manhole. Only a city or sanitary district may apply for a trunk connection permit since the agency agrees to own, operate, and maintain the lateral connecting to the OCSD manhole. We will require a profile view of the proposed connection. The proposed soffit (top) of the connecting pipe should match the soffit of the trunk sewer and the slope of the proposed connection shall not be greater than 10%. Please include a manhole detail, plan view and to scale, showing the proposed connection to the OCSD manhole. The detail should show the existing and proposed manhole channels, the shelf area, and the invert elevations.

Once we receive your plans, we can expand on our requirements. The OCSD design guidelines book is attached for your reference/use. I also included the current rate table for Capital Facilities Capacity Charges and inspection fees to estimate the OCSD fees/charges for this development. Let me know if you have any questions.

Regards,



Rudy Davila

Orange County Sanitation District

Planning | Engineer

Office: 714.593.7348 | www.ocsewers.com



From: Katie OConnor [mailto:KOConnor@hunsaker.com]

Sent: Tuesday, November 17, 2015 9:36 AM

To: Davila, Rudy <RDavila@OCSD.COM>

Subject: Tract 17845 Sewer System Hydraulic Analysis : submitted July 30, 2015

Rudy,

I got your voice mail message on Oct 29, 2015. I have returned your call and left voice mail messages several times since then. We seem to have different schedules, so I thought I would answer your questions via email in hopes that we can get through the plan check comments this way. The questions that you left on my voice mail on October 29, 2015 are listed below with my responses.

Question/Comment 1) There does not seem to be a table summary of the flow that goes into the existing system at each connection point.

H&A Response: *There is a table in the report entitled "Tract 17845 Sewer Demand Calculations" (located on page 6.) This table shows each reach and how the demands were calculated for each reach, based on average*

daily flow coefficients and tributary acreage. A peaking factor of 2.5 is applied to each average daily flow and the peaked flow is used in the hydraulic analysis. There are three connection points to the existing system. Two of the connection points join directly into an OCSD trunk line and the third joins into a City of La Habra sewer main. Below is a summary of the flows into the existing system.

CONNECTION LOCATION SYSTEM	PIPE NUMBER	PEAKED FLOW ADDED TO EXISTING
<i>BEACH BLVD (OCSD Trunk) CFS</i>	29	0.32
<i>IMPERIAL HWY (OCSD Trunk) CFS</i>	30	0.70
<i>IDAHO (City of La Habra sewer)</i>	11	0.12 CFS

Question/Comment 2) Is the peaking factor of 2.5 considered in the input data for the calculations?

H&A Response: *Yes, all flows are peaked.*

Question/Comment 3) Finding #6 states that OCSD defines single family residential projects as low density developments. This is not necessarily the case but is probably alright for this project.

H&A Response: *A combination of low density and high density flows were used for the proposed development. In areas where single family residential homes are proposed, a low density land use with a average daily flow coefficient of 1488 gpd/acre is applied. In areas where multi-family homes are proposed, a high density land use with an average daily flow coefficient of 7516 gpd/acre is applied. Please see the table in the report entitled “Tract 17845 Sewer Demand Calculations” (located on page 6) for the land use density designated for each reach of pipe.*

Please let me know if there are any additional questions that I can answer for you.

Sincerely,

Katie O'Connor, P.E.

Hunsaker & Associates

Three Hughes Irvine, CA 92618

Office: (949) 458-5437

DESIGN and CONSTRUCTION REQUIREMENTS for SANITARY SEWERS

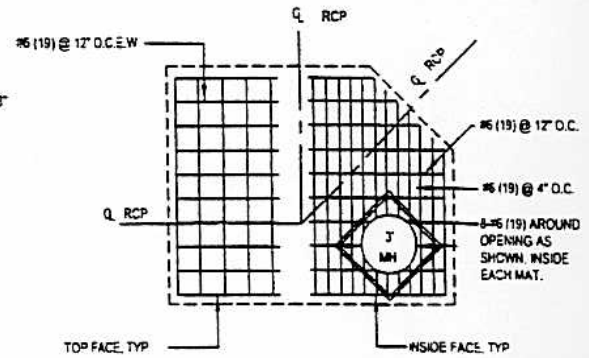
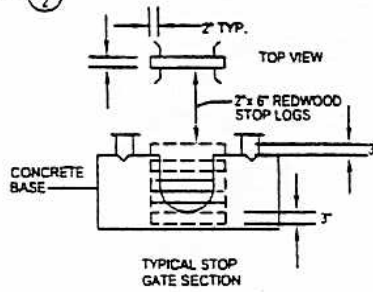
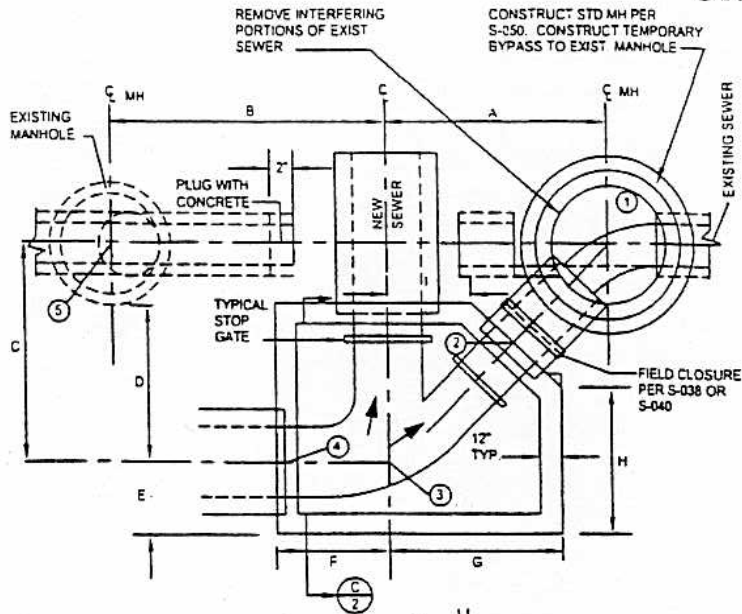

SECTION D
NTS
TOP SLAB ONLY

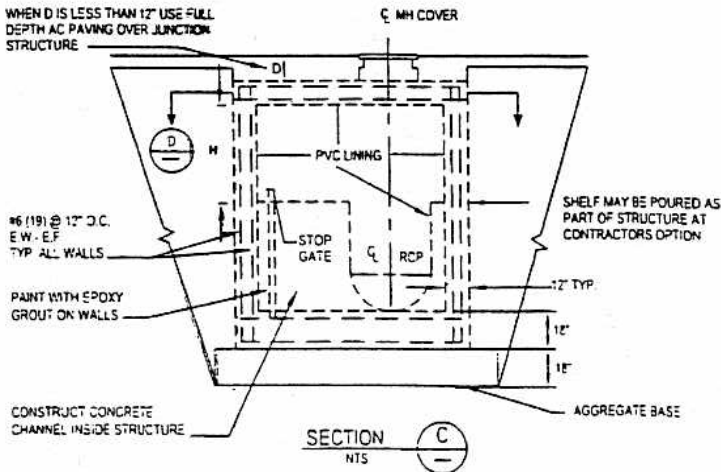

SECTION C
NTS



**Orange County Sanitation District
California**

12 SANITARY SEWERS – DESIGN AND CONSTRUCTION REQUIREMENTS

Table of Contents

12	SANITARY SEWERS – DESIGN AND CONSTRUCTION REQUIREMENTS.....	12-i
12.0	HISTORY OF CHANGE.....	12-1
12.1	DEFINITIONS	12-2
12.2	INSTRUCTIONS TO DEVELOPERS, ENGINEERS, AND HOMEOWNERS.....	12-3
12.2.1	AUTHORITY	12-3
12.2.2	LOCAL SEWAGE AGENCY.....	12-3
12.2.3	ANNEXATIONS.....	12-3
12.2.4	PERMITS.....	12-3
12.2.5	PLAN CHECKING, APPROVALS AND FEES.....	12-4
12.2.6	INDEMNITY BOND	12-4
12.2.7	EASEMENTS AND RIGHT-OF-WAY.....	12-4
12.3	INSTRUCTION TO DESIGNERS	12-5
12.3.1	GENERAL	12-5
12.3.2	PLANS	12-5
12.3.3	DESIGN	12-6
12.4	CONSTRUCTION	12-14
12.4.1	SURVEYS	12-14
12.4.2	WORK INCLUDED	12-15
12.4.3	SCHEDULE	12-15
12.4.4	NOTICE	12-15
12.4.5	PERMITS.....	12-15
12.4.6	STOP ORDERS	12-16
12.4.7	CHANNEL OF COMMUNICATION.....	12-16
12.4.8	CONTRACTORS LICENSE.....	12-17
12.4.9	INSURANCE.....	12-17
12.4.10	LEGAL RELATIONS AND RESPONSIBILITY	12-17
12.4.11	FOUNDATIONS OR UNSUITABLE MATERIAL	12-17
12.4.12	OVEREXCAVATION	12-17
12.4.13	ODOR CONTROL.....	12-18
12.4.14	TEMPORARY HANDLING OF SEWAGE FLOW	12-19
12.4.15	DEWATERING.....	12-24
12.4.16	TRENCH WIDTH	12-24
12.4.17	TRENCH BACKFILL	12-24
12.4.18	HOUSE LATERALS	12-25
12.4.19	MANHOLES	12-26
12.4.20	PRESSURE SEWERS	12-28
12.5	MATERIALS.....	12-29
12.5.1	GENERAL	12-29
12.5.2	VITRIFIED CLAY PIPE	12-29
12.5.3	REINFORCED CONCRETE PIPE	12-35

12.5.4	DUCTILE IRON PIPE	12-39
12.5.5	PRECAST MANHOLES	12-40
12.5.6	GRADE RINGS.....	12-41
12.5.7	MANHOLE FRAME AND COVER.....	12-41
12.5.8	EPOXY RESIN.....	12-41
12.5.9	PORTLAND CEMENT CONCRETE.....	12-42
12.6	TESTING	12-42
12.6.1	GRAVITY SEWERS	12-42
12.6.2	PRESSURE SEWERS	12-45
12.6.3	MANHOLES	12-46
12.7	SAFETY	12-46
12.7.1	EXCAVATIONS	12-46
12.7.2	CONFINED SPACE OPERATION.....	12-46
12.7.3	TRAFFIC CONTROL	12-47
12.8	REFERENCES - STANDARD DRAWINGS.....	12-47

12.0 HISTORY OF CHANGE

Revision and Version	Author	Date	Change
D1	WC	June 2001	Updated the 1992 Edition of the Standard and included it in the Guidelines book.
E	PM	Jan 2003	Updated manhole requirements
F	C.Winsor	Mar 2006	Expanded the CCTV requirements; Updated the list of OCSD Standard Drawings referenced herein
F.1	M.Taylor	May 2007	Updated thrust resistance and manhole frame and cover requirements.
F.2	J.Shubik	Aug 2009	Corrected the list of referenced standards drawings. Updated insurance requirements.
G	M.Taylor	Aug 2010	Updated manhole requirements.
H	M.Taylor	Jan 2012	Added requirements for odor control and temporary handling of sewage. Made other minor edits.
I	D.Philips	Sept 2012	Clarified siphon criteria and vinyl plastic liner language.
J	D. Philips	Feb 2014	Added fPVC and HDPE to pressure sewers. Deleted PE wrap for DIP. Added anodic protection etc. to buried DIP and epoxy; color coat for exposed.

WC:js
Chap12-Sanitary Sewers-Design-n-Construction Reqtcs

12.1 DEFINITIONS

District – Orange County Sanitation District (OCSD).

Engineer – The Director of Engineering of the Orange County Sanitation District or duly authorized agent of the Director of Engineering.

Design Engineer - A private Professional Engineer hired by the Owner or Developer for the design of the proposed Work.

Inspector – Inspector, in these requirements, shall only mean a duly authorized representative of the Orange County Sanitation District.

Owner or Developer – The applicant requesting the installation or construction of sanitary sewers for the integration with the collecting sewer system of the District.

Contractor – The persons, firm or corporation entering into contract with the Owner or Developer for the performance of Work required under said contract, the District ordinances and these requirements.

Work – All the work specified in the standard requirements, plans and standard drawings necessary to complete the construction of sanitary sewers.

Approved Plans – Construction plans as specified herein approved by the Orange County Sanitation District attested to by the Engineer's signature.

Approved Equal – A material or product that exceed or is equivalent to, in the opinion of the Engineer, in all respects, that which is specified herein.

Plans – That part of the Approved Plans and specifications which consist of the plans, profiles, typical cross-sections and working drawings or exact reproductions thereof which show the location, character, dimensions and details of the Work to be done.

Standard Drawings - That part of these requirements titled, "Standard Drawings".

State Specification - The Standard Specifications, State of California, Department of Transportation (Caltrans), latest edition.

Master Specifications - The Master Specifications, Orange County Sanitation District, latest edition.

ASTM - The American Society for Testing Materials. All references to the specifications of the ASTM are understood to refer to the current editions as revised and/or amended at the date of construction.

Drafting Manual - The Drafting Manual for Environmental Management Agency, Design Division and Traffic Engineering of the County of Orange, December, 1984.

Construction Manual – The Construction Safety Manual of the County Sanitation District, September, 1983.

OSHA - Code of Federal Regulations, Title 29, Part 1910, U.S. OSHA, and State of California, Code of Regulations, Title 8, Construction Safety Orders.

Clean Sand - Wherever the term “clean sand” is used in these requirements, it shall be defined as a soil having sand equivalent of 70 as determined in accordance with California Department of Transportation, Test No. “California 217”.

Final Acceptance – The formal action by the District accepting the Work as fully completed, in accordance with these requirements.

12.2 INSTRUCTIONS TO DEVELOPERS, ENGINEERS, AND HOMEOWNERS

12.2.1 AUTHORITY

The authority for the Work is the District’s Engineering Design Guidelines, Master Specifications and Standard Drawings, latest editions. This booklet excerpts from those documents and does not supersede same.

Prior to the preparation of any plans, specifications or descriptions, the Developer (or the Developer’s engineer) shall meet with the staff to determine the extent of the District’s requirements for providing service to the development by the District.

12.2.2 LOCAL SEWAGE AGENCY

If the local sewage agency is not the District, construction and design shall be in accordance with applicable local codes and standards, except that the connection to District’s trunk system shall be in accordance with this Book.

12.2.3 ANNEXATIONS

The Developer (or the engineer for the Developer) shall pick up instructions for Annexation to Orange County Sanitation District. Contact the Engineering Department, Planning Division, to verify if your property is in the District.

12.2.4 PERMITS

No work shall be started until the Contractor has obtained all necessary permits. The Contractor shall obtain all permits and give all notices necessary and incidental to the due and lawful prosecution of the work, and to the preservation of the public health and safety. The District will issue a permit for the Work to be done in conjunction with District

facilities. The Contractor shall obtain and pay for all permits required by other agencies having jurisdiction over the Work.

12.2.5 PLAN CHECKING, APPROVALS AND FEES

Prior to the construction of any facilities for the District (or facilities to become the property of the District), construction drawings for the subject Work shall be subject to approval by the Engineer, and shall be stamped and signed by the Design Engineer preparing the Plans.

Approval by the Engineer on drawings for facilities to become the property of the District shall apply only to general design concepts with respect to the District's master planned capacity, maintenance procedures, and quality of materials. This will signify approval for a permit for construction, but will not guarantee the absence of errors and omissions.

When plan checking by the District is necessary, a plan check deposit fee of \$100 per sheet of plans with a minimum cost of \$250 shall be deposited with the District.

After approval of the plans and prior to the beginning of construction, a deposit equal to six (6) percent of the construction costs (less the cost of the plan checking fee on deposit) of the sewer facilities as estimated by the District shall be made to the District. At the completion of the Work, actual costs incurred by the Districts in plan checking and inspection shall be computed, at which time the Developer may be required to pay additional monies if necessary.

12.2.6 INDEMNITY BOND

If sewer facilities are to be constructed in a right-of-way under the jurisdiction of an agency requiring the District to sign the application for the encroachment permit, the applicant shall furnish the District with an indemnity bond satisfactory to the District prior to execution of the application.

12.2.7 EASEMENTS AND RIGHT-OF-WAY

Permanent easements, where absolutely necessary, shall be a minimum of 30 feet in width and shall be shown on the plans. Temporary easements for construction only shall be shown on the plans including date of termination.

Where applicable, permanent easements shall be recorded on the tract map, and granted to the Orange County Sanitation District. When applicable, separate easement documents for both permanent and temporary easements shall be prepared (on standard OCSD title sheets and Standard Plan and Profile sheets) and presented to the District for acceptance and recording.

The District may accept sewers on private streets upon granting of an easement to the District when a road (20-foot wide minimum) is provided for access to manholes and sewer line.

If a flush truck cannot drive the entire length of a sewer and is able to turn around, the District will not accept the sewer easement.

12.3 INSTRUCTION TO DESIGNERS

12.3.1 GENERAL

All Work shall be delineated in accordance with the standards, exhibits and requirements of the Drafting Manual.

12.3.2 PLANS

1 COVER SHEET

The cover sheet shall be the Orange County Sanitation District standard sheet. A standard blank cover sheet will be provided upon request by the District, and include at a minimum the following:

- As a minimum, the cover sheet will delineate:
 - Vicinity Map (General Orange County/L.A. area)
 - Location Map and Sheet Index Map (Specific location)
 - Name of project including contract number, title and district number
 - Approval blocks for signature of all agencies required, in addition to the signature block of the Design Engineer preparing the plans and the Engineer's approval block.
- General notes which describe Work to be done in summary terms.
- In lieu of that shown (and when applicable), a separate survey control sheet shall be prepared delineating horizontal and vertical survey control, bench marks, abbreviations, legend delineations and other applicable data which may be included thereon.

2 PLAN AND PROFILE

- All Work shall be shown and delineated in accordance with the applicable portions District's CAD Manual.
 - Scale shall be 1" = 40' (horizontal), and 1" = 4' (vertical). Any other scale should receive pre-approval from the Engineer.

- Construction notes and numbers shall not be used and all applicable notes of construction shall be called out.

- Typical section, hydraulic data, and benchmark data shall be shown.

- Soil boring information shall be shown on each sheet (if applicable) and shall include the date taken and the firm presenting the soil information.
- Utility locations shall be shown as accurately as possible in both plan and profile in accordance with standard practice for underground utility plans delineations.

3 DETAILS

Applicable detail sheets shall be prepared and should show all necessary details for construction survey controls.

4 SIZE OF PLANS

All plans shall be 22 x 36 inches in size.

5 FINAL APPROVAL

The plans shall be signed by a Civil Engineer Registered in the State of California, under whose jurisdiction the plans were prepared. When final approval for a permit is issued by the District, the Engineer's signature will be shown.

12.3.3 DESIGN

1 CRITERIA FOR AVERAGE DAILY FLOW CALCULATIONS

<u>Land Use</u>	<u>Coefficient GPD Per Acre</u>
Low Density Residential	1488
Medium Density Residential	3451
High Density Residential	7516
Commercial Area	2262
Industrial Area	3167
Open Space	129

2 PEAK FLOW

Average daily flow times two (2) equals peak flow. For a 8-inch pipe use multiplication factor of 2.5. Do not use pipe less than 8 inches in diameter.

3 VELOCITY

Velocity shall not be less than 2 ft /sec. Unless otherwise approved by the Engineer. Maximum slope should not exceed 10 percent.

4 REQUIREMENTS FOR DEPTH OF FLOW (D) VERSUS DIAMETER OF PIPE (D) IN SEWER PIPE.

<u>Diameter of Pipe (d)</u>	<u>Max D/d</u>
8 inches – 18 inches	0.50
21 inches – 60 inches	0.75
Over 60 inches	0.75

5 DEPTH OF COVER

Minimum depth of cover over mainline sewers shall be 7 feet. Unless otherwise approved, depth of laterals at property line shall be a minimum of 5 feet.

6 MANHOLE CRITERIA

Manhole locations:

- At changes of slope
- At changes of direction
- At junction of laterals
- At changes of pipe size
- At termination of sewers
- At special locations as designated by the Engineer
- At changes in type of pipe material, i.e., V.C.P. to D.I.

Maximum distance between manholes:

<u>Pipe Size</u>	
8 inches – 12 inches	400 feet
15 inches – 18 inches	500 feet
18 inches and over	600 feet unless otherwise approved by the Engineer

7 SIPHON CRITERIA

- Siphons should be avoided where possible.
- Where practical, dual siphons are preferred to allow isolation of one for maintenance and inspection.
- Siphons should be designed for a minimum velocity of 3 feet per second at design average flows, except that for cleaning purposes siphons shall have a minimum internal diameter of 8-inches.
- Siphons should be designed so that the daily dry weather half hour peak flow shall provide a minimum velocity of 4 feet per second. That is, under average conditions at least once per day the flow should be at or above 4 feet per second for at least 30 minutes.
- Siphons should be designed so that peak wet weather flow produces no more than 2-feet of surcharge (above the soffit of the pipe) in the upstream siphon structure (or any other manhole).
- For corrosion reasons, plastic pipe (pressure rated HDPE or PVC) is preferred for siphons and air lines. If VCP is used it shall be concrete encased.
- Siphons shall not have sharp horizontal angles or changes of grade.
- The invert of the downstream manhole should be at least 0.1-feet lower than the invert of the upstream manhole.
- The maximum angle of the downstream (rising) leg approaching the outlet junction structure should be no more than 15 degrees from horizontal. The maximum angle of the upstream leg should be no more than 30 degrees from horizontal.
- Siphons shall have a junction structure at each end. Rectangular junction structures are preferred over circular structures where there are more than one siphon pipe connected to the structure.
- Where used, multiple, reduced sized siphons shall be based upon a detailed engineering flow analysis. Flow analysis shall consider present and future low, average, and high flows. Particular attention should be paid to average diurnal flow conditions.
- Dual (or multiple) siphons should be designed so that normal flow can be diverted to either barrel so that the other barrel can be cleaned. To reduce maintenance requirements, isolation of siphon pipes should be done using stop plates (or logs), not gates. Junction structures and stop plates should be designed so that plates can be moved to isolate or open siphons without a confined space entry.
- Where multiple siphons are used the inverts should be at the same elevation, and the isolation stop plates should be provided that can be used as overflow weirs between the siphon pipes
- Siphons should have an adequately sized air jumper line between junction structures, which shall be a minimum of 6-inch diameter for cleaning and maintenance. Dual air lines are not required. Provide the design basis including calculations in the design report.
- Air jumper systems should have a mechanism for removing condensate. Condensate removal shall be sized based on an engineered calculation of

condensate production, and OCSD experience, and should be designed to provide long service in corrosive conditions. Design shall specify minimum slope for drainage. Where practical, overhead air jumpers that are self draining to the manholes are preferred.

- Siphons and air balance lines shall be designed to accommodate OCSD’s cleaning methods, including rodding, jetting, and tire cleaning. Locate manholes so that they are accessible, and to minimize traffic control setup. Adequate space shall be provided for equipment setup and vehicle parking, including a buffer for safety. Provide utility truck parking area on the downstream side of the upstream manhole.
- Air jumpers should have a headloss of less than 0.10-inches of water column (0.0036 psi) across the system at maximum airflow. The following method for estimating the maximum airflow (Q_{air}) is suggested (from Project 2-68 PDR TM-1, Dudek & Associates, 2006):
 - Assume $d/D = 0.3$ (because maximum airflow occurs at $d/D = 0.3$).
 - Assume a Reduction Factor (RF) = 0.5 to relate air velocity (V_{air}) to sewage velocity (V_{ww}).
 - If replacing an existing air jumper, RF may be modified based on field measurements of Q_{air} , d/D and Q_{ww} , but never to be below 0.25 or above 0.8 (except where mechanical ventilation affects airflow).
 - $Q_{air} = (RF)(\text{HeadspaceArea})(V_{ww})$.
- Identify all siphon pipe inverts on the plans. Accurately specify actual internal diameters (ID) for all designed pipelines in the construction drawings. If more than one pipe material is allowed in the design, show both actual IDs. The nominal size of the pipe is not sufficient.
- Specify procedures for pressure testing of siphons and air jumpers.
- Specify CCTV of siphons and jumpers for acceptance.

Note: OCSD typically cleans jumpers and smaller (<21-inch) siphons with a jetter, and larger siphons with tires. OCSD’s largest tire is 48 inches, which OCSD uses to clean the largest (96-inch) siphons. (OCSD cleans with a tire by parking a large utility truck with a winch and pulley system at the upstream manhole and allows the flow to push the tire downstream against the resistance of the cable.) Cleaning lengths are limited to about 1100 feet for tire cleaning, and a little less than 900 feet for jet cleaning. Cleaning lengths include upstream manhole depth as well as sewer length. (Information current as of 2012 equipment; consult with Collections Maintenance for updated requirements.)

8 RADIUS OF CURVATURE

Normally, the District insists upon straight sections between manholes; however, when specifically approved by the Engineer, minimum radius of curvature for V.C.P. sewers shall be:

Pipe Size

8 – 12 inch

250 feet

15 – 18 inch	350 feet
21 – 27 inch	400 feet
30 – 39 inch	450 feet
Over 39 inch	500 feet

Lesser radius of curvature may be permitted by the Engineer in special cases. Vertical curves shall not be allowed.

9 SHOP DRAWINGS

Shop drawings for all fabricated materials or equipment incorporated in the Work shall be submitted for approval by the Engineer. The Contractor shall obtain and check the shop drawings and other pertinent data for conformance with all requirements of the drawings and specifications. After completion of such checking and verification, the Contractor shall submit four copies of the shop drawings and pertinent data to the District. It shall be in such detail as the Engineer may require for information as to the design, installation and operation of such items and their compliance with the Plans and Specifications.

10 CRITERIA FOR THE SEPARATION OF WATER MAINS AND SANITARY SEWERS

Basic Separation Requirements

Water mains and sewers should be separated as far as is reasonable in both the horizontal and vertical directions with sewers always lower than water mains.

Parallel Construction: The horizontal distance between pressure water mains and sewers shall be at least 10 feet.

Perpendicular Construction (crossing): Pressure water mains shall be at least three feet above sanitary sewers where these lines must cross.

Exceptions to Basic Requirements

Certain local conditions of topography, available space, etc. may create a situation where there is no alternative but to install water mains or sewer lines at less than the required separation. In such cases, more rigid construction requirements shall be met as specified in section entitled "Construction" herein, subject to the special provisions and restrictions given in the following paragraphs under "Special Construction Requirements".

The basic requirements apply to sewers of 24 inches in diameter or less. Larger sewers may create special hazards because of flow volumes and type of joints used. Each installation of sewer larger than 24 inches in diameter shall be reviewed in advance to determine if the separation and protection provided to nearby water mains is adequate.

Special Construction Requirements

The special construction requirements necessary for sewers or water mains where the minimum required separation cannot be maintained are given in Exhibit No. 1 below. There are three situations encountered in the field:

Case 1 – New Sewer – Existing water main

Case 2 – New water main – Existing sewer

Case 3 – New water main and new sewer

For Case 1 and 3 the special construction requirements apply to the sewer. For Case 2 the special requirements may apply to either or both the water main and sewer.

The special construction requirements shall apply to house laterals that cross above a pressure water main but not to those house laterals that cross below a pressure water main.

The special construction requirements given are for the normal conditions found with sewage collection lines and water distribution mains. More stringent requirements may be necessary for special circumstances such as water mains buried deeper than normal, unstable soil conditions, high ground water, etc. These situations shall be reviewed with the Health Department in advance.

The special provisions and restrictions given in the following paragraphs under “Special Provisions and Restrictions” shall be followed.

Special Provisions and Restrictions

- Sewer force mains shall not be permitted to be constructed over water mains. Force mains constructed parallel to water mains shall have the required separation as given in the previous paragraphs under “Basic Separation Requirements” regardless of construction. When sewer force mains must cross under water mains, special approval by the Engineer shall be obtained in advance.
- Construction of any sanitary sewers within 25-foot horizontal distance of low head water mains shall be reviewed and approved by the Engineer in advance. (Low-head water mains are defined in the California State Health Department Policy as any water main which has less than 5 psi at any time at any point in the main).
- Where a sewer must cross over a water main, it should cross at a 90-degree angle if possible and the length of sewer pipe shall be centered on the water main so the sewer joints are the maximum distance from the water main.

- In pressure testing new water mains and/or sewers, special attention should be given to those areas where the lines are in close proximity.

**EXHIBIT NO. 1 TO
REQUIRED SEPARATION BETWEEN WATER MAINS AND SANITARY SEWERS**

**SPECIAL CONSTRUCTION REQUIREMENTS
Where Required Separation Cannot Be Maintained**

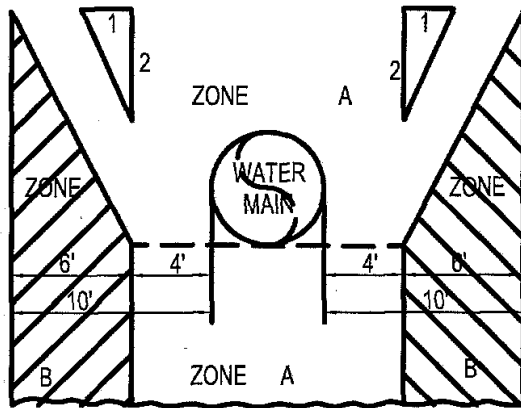

PARALLEL CONSTRUCTION
not to scale

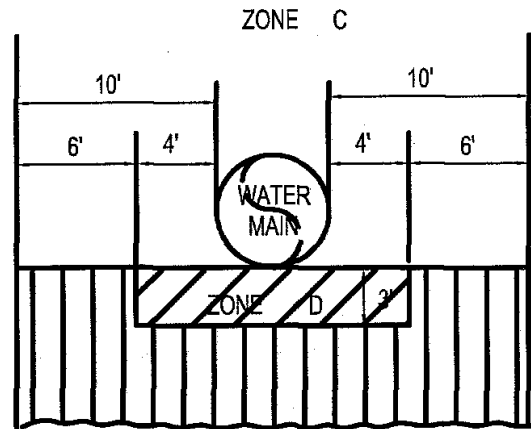

PERPENDICULAR CONSTRUCTION
not to scale

Notes: Dimensions are from outside of water main to outside of sewer. Compression and mechanical joints and reinforced concrete encasement are as defined at the end of this section.

CASE 1 AND 3: NEW SEWER BEING INSTALLED

ZONE

- A. Sewer lines will not be permitted in this zone without special permission from the Department of Health.
- B. Extra-strength vitrified clay pipe with compression joints; or concrete collars around the joints, which collars shall have a minimum distance along the pipe of six inches on either side of the joint; or rubber gasket reinforced concrete pipe meeting OCSD Standards; or rubber gasketed SDR 26 ASTM D3034 rubber gasketed PVC sewer pipe;.
- C. or D. AWWA C110 Pressure Class 100 or thicker ductile iron pipe, with a lining and coating of high build epoxy meeting OCSD Standards, and approved mechanical joints; jointed or

fusion welded AWWA C900 or C905 Pressure Class 100 or thicker PVC pipe; or any sewer pipe within a continuous steel casing, which casing shall have a thickness of not less than one-fourth inch and with all voids between sewer pipe and casing pressure grouted with one sack slurry.

CASE 2: NEW WATER MAIN BEING INSTALLED – EXISTING SEWER

If an existing sewer is located within Zone A, B, C or D of a proposed water main, the following special requirements shall apply:

ZONE

- A. No water mains shall be constructed without special permission from the Department of Health.
- B. If the sewer does not meet the Zone B requirements given above the water main shall be of AWWA C110 Pressure Class 150 or thicker ductile iron pipe, AWWA C900 Pressure Class 150 or thicker PVC pipe, or equivalent.
- C. No water mains shall be constructed without special permission from the Department of Health. If permission is granted, the sewer shall be encased with reinforced concrete and the water main shall meet the requirements of Zone B above.
- D. The water main shall meet the requirements of Zone B above and the existing sewer shall be encased with reinforced concrete.

DEFINITIONS:

1. Compression joints are rubber ring or gasket joints.
2. Mechanical joints are bolted joints.
3. Acceptable reinforced concrete encasement is as follows (not to scale):

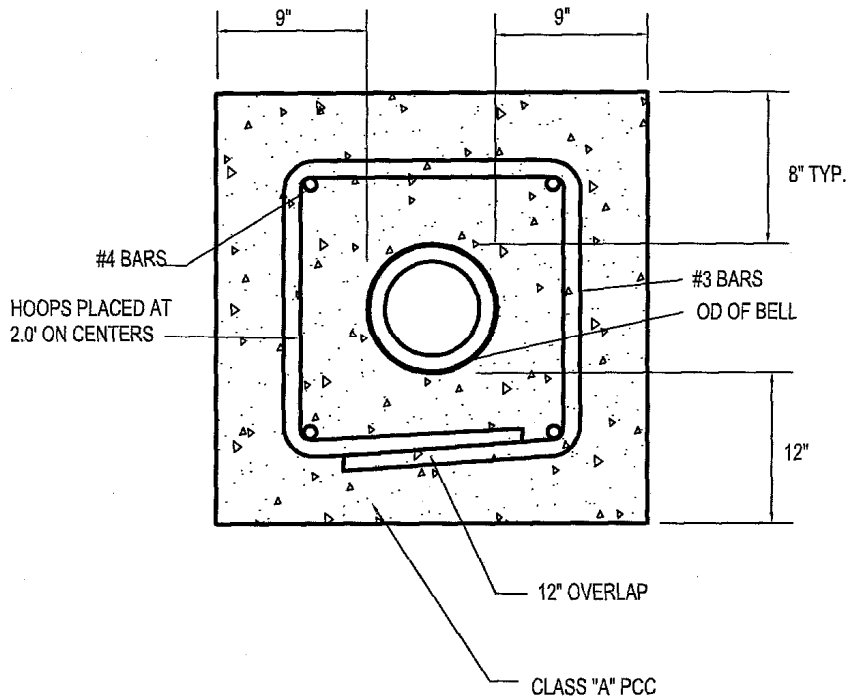

12.4 CONSTRUCTION

12.4.1 SURVEYS

All surveys shall be done by a licensed land surveyor or civil engineer as required by the State of California and shall be completed and shown on the plans in accordance with the Manual of Practice for Surveys latest edition.

Surveyors Cut Sheets: No work shall commence prior to the preparation of the sewer cut sheets and duplicate copies supplied to the Inspector. The cut sheets shall be prepared only by a Land Surveyor Licensed or Civil Engineer Registered in the State of California. The cut sheets shall include the location of wyes, house laterals at the property line and manhole rim elevations by sewer stationing. House lateral stakes shall be marked to indicate cut, sewer stationing and lot number.

12.4.2 WORK INCLUDED

Principal items of Work for the construction of sewer mains and laterals shall include, but not be limited to, the following:

- Traffic Control
- Clearing and grubbing or pavement removal
- Odor control and temporary handling of sewage
- Trenching and shoring
- Pipe bedding
- Pipe laying
- Construction of structures
- Placing and compacting of backfill
- Balling and cleaning of sewer
- Air testing of sewer
- Paving or grading over trench
- Raising manhole covers to grade
- Final inspection.

12.4.3 SCHEDULE

The Contractor shall submit a schedule to the Engineer outlining his proposed construction operation. Whenever the Contractor varies the period during which work is carried on each day, the Contractor shall give due notice to the Engineer so that proper inspection may be provided. At such time as the Contractor's work on the sewer becomes less than a full day's activity, it shall be the Contractor's responsibility to notify the Inspector, on a daily basis, of the Work requiring inspection. Any Work done in the absence of the Inspector shall be subject to rejection. Inspections shall not be scheduled on Fridays without prior permission by the District.

12.4.4 NOTICE

Notice shall be given to the Engineer at least two working days in advance of commencement of work.

12.4.5 PERMITS

The Owner (s), Developer, or their Contractor shall secure all excavation permits and all licenses required for the Work. Copies shall be recorded with the District prior to commencement of work.

Special attention is called to the District's connection charges and it shall be the Owner's responsibility to ascertain these charges and pay for such prior to any connections to the District sewerage facilities, including lateral connections at property lines.

12.4.6 STOP ORDERS

If the Contractor (for the Owners or Developer) fails to prosecute the work, or any separate part thereof in accordance with the notes, details, plans, or the applicable portions of these specifications, or the permit requirements therefore, the District may, without prejudice to any other right or remedy, serve written notice upon the Contractor and the sureties of the intention to terminate all work by the Contractor. The said notice will contain the reasons for such intention to terminate all work by the Contractor and, unless, within 10 days after the service of such notice, such violations cease, and satisfactory arrangements for the corrections thereof are complete, the final termination notice shall be issued.

In the event of any such termination, the District shall immediately serve written notice thereof upon the surety and Contractor. The surety shall then have the right to take over and perform the Contract provided, however, that, if the surety within 15 days after the serving of a notice of termination does not give the District written notice of its intention to take over and perform the work, or does not commence performance thereof within 30 days from the date of serving said notice, the District may take over the work and prosecute the same to completion by Contract or by any other method it may deem advisable for the account and at the expense of the Contractor and the sureties, who shall then be liable to the District for any excess cost or other damage occasioned the District thereby. In such event, the District may, without liability for so doing, take possession of and utilize in completing the work such materials, appliances, plants, and other property belonging to the Contractor that may be on the work site and be necessary therefore. For any portion of such work that the District elects to complete by furnishing its own employees, materials, tools, and equipment, the District shall be compensated for such in accordance with the schedule of compensation for force account work.

12.4.7 CHANNEL OF COMMUNICATION

Any notice required or given under the contract shall be in writing, be dated, and signed by the party giving such notice or his duly authorized representative, and be served as follows:

- If to the District: by personal delivery or by deposit in the United States mail.
- If to the Contractor: by personal delivery to the Contractor or to his authorized representative at the site of the project or by deposit in the United States Mail.
- If to the Surety or any other person: by personal delivery to said Surety or other person or by deposit in the United States mail.

All mailed notices shall be in sealed envelopes, shall be sent by certified mail with postage prepaid, and shall be addressed to the addresses indicated in the Contract Documents, or such substitute addresses which a party designates in writing and serves as set forth herein.

12.4.8 CONTRACTORS LICENSE

All work shall be performed by a contractor licensed in the State of California with the designation of Class A or C-42.

12.4.9 INSURANCE

Prior to commencement of subject work, the Contractor, in addition to other requirements with respect to insurance, shall provide the District with a Certificate of Insurance in the amount of \$1,000,000 General Liability policy. A Certificate of Insurance shall be presented to the District before inspection is scheduled and performed. If the permit connection is for an agency or a City, the District shall be added to their policy as an additional insured endorsement. Higher insurance requirements may be required depending on the scope of work and will be determined by the District when the permit is issued.

12.4.10 LEGAL RELATIONS AND RESPONSIBILITY

The Contractor shall keep himself fully informed of all laws, ordinances and regulations which in any manner affect those engaged or employed in the Work, or the materials used in the Work, or which in any way effect the conduct of the Work and of all such orders and decrees of bodies or tribunals having any jurisdiction or authority over the same. If any discrepancy or inconsistency is discovered in the plans, drawings, specifications or other documents in relation to any such law, ordinance, regulation, order of decree, the Contractor shall forthwith report the same to the District in writing. The Contractor shall at the time observe and comply with and shall cause all of his agents and employees to observe and comply with all such existing and future laws, ordinances, resolutions, regulations, orders and decrees and shall protect and indemnify the District and the Board of Directors, and all of its and their officers and agents, against any claim or liability arising from or based on the violation of any such law, ordinance, regulation, order or decree, whether by himself or his employees.

12.4.11 FOUNDATIONS OR UNSUITABLE MATERIAL

If excessively wet, soft, spongy, unstable or similarly unsuitable material is encountered at the surface upon which the bedding material is to be placed, the unsuitable material shall be removed to a depth as determined in the field by the Engineer and replaced with 3/4-inch maximum crushed base rock.

12.4.12 OVEREXCAVATION

All overexcavation as determined by the Engineer shall be rectified by the placement of 3/4-inch maximum crushed rock base to the springline of the pipe.

12.4.13 ODOR CONTROL

1 GENERAL

Work Description

When the Work of the project includes opening live sewer lines, the Contractor shall adhere to the following odor control requirements.

The Contractor shall furnish all labor, materials, and equipment required, and shall carry out effective measures wherever and as often as necessary to prevent the discharge of a nuisance odor in keeping with the District's goal of no odor complaints. During construction, the Contractor shall notify the Engineer and the Inspector at least forty-eight (48) hours in advance when potential odor-causing activities are scheduled for construction.

Contractor Submittals

The Contractor shall develop and submit to the Engineer, for review, an Odor Control / Monitoring Plan (OCMP). The OCMP shall be developed and submitted to the Engineer a minimum of twenty one (21) days prior to any construction activity that may potentially release nuisance odors. The OCMP shall contain the following:

- Site locations of all potential odor-causing activities within the Work area
- Scheduled construction date(s)
- Expected construction duration(s)
- List of potential receptors and distances to those receptors
- Proposed locations of odor monitors
- Plan for odor monitoring using the gas monitors
- Catalog cuts for gas monitors
- Operation and maintenance procedures to prevent odors
- Mitigation measures
- Emergency contact numbers
- Emergency equipment.

2 PRODUCTS

The Contractor shall obtain fully functioning and calibrated hydrogen sulfide gas analyzers to measure hydrogen sulfide emission concentrations from potential odor areas during construction.

Hydrogen Sulfide Gas Monitors

The Contractor shall provide a minimum of two (2) low range hydrogen sulfide monitors to measure and record concentrations from 0.01 to 2.0 ppmv and include the ability to print out results in graphic formats. The preferred equipment shall be Low Range OdaLog Loggers as manufactured by App-Tek International Pty. Ltd., Jerome Meter as manufactured by Arizona instruments, or equal.

Field Olfactometer

The Contractor shall provide one field olfactometer to determine the overall odor of all emissions. The Nasal Ranger by St. Croix Sensory shall be the preferred instrument with the standard dial which provides dilutions of 2, 4, 7, 15, 30, and 60 D/T, or equal.

Gravel Bags

The Contractor shall provide gravel bags to hold the rubber sheeting in place.

3 EXECUTION

Odor control measures shall be implemented during all activities that include, but are not limited to: opening of the collection system facilities (i.e., pipes, structures), demolition, tie-ins, sewage bypassing, and dewatering.

The Contractor shall seal all structures properly to eliminate the potential for release of nuisance odors.

The Contractor shall stop all work that creates a complaint, and mitigate the cause to the satisfaction of OCSD prior to resuming work.

12.4.14 TEMPORARY HANDLING OF SEWAGE FLOW

1 GENERAL

Work Description

The Contractor shall be responsible for the temporary handling of sewage throughout the construction of this project. This includes field verification of flows; design, installation and operation of a temporary pumped bypass system; and a Spill Prevention, Control and Countermeasure Plan (SPCCP), including a

Contingency Plan detailing actions to be taken in the event of a sewage spill. All spills shall be contained and returned to the sewer system.

The Contractor may use flow through piping (in-line bypass) installed in the manhole as a bypass solution. In-line bypasses shall be as large as possible and verified continuously to be free flowing.

Aboveground by-pass sewage pumping is permitted upon approval by the Engineer and in accordance with the requirements of this specification section. If aboveground bypass is required, a single aboveground HDPE bypass pipeline and system shall be provided with pumps, piping and vehicle crossing ramps as specified herein. All aboveground sewage bypassing systems shall be sealed to eliminate the potential for release of nuisance odors.

The Contractor shall be responsible for all aspects of the mobilization, set-up, operation, testing, management, 24-hour trained personnel for monitoring and operation, pressure testing, spill containment at all points of suction, discharge, and ramp crossing connections, spill management including clean up, replacement of damaged property and fines.

Contractor Liability

The Contractor shall be responsible for the continuity of sanitary sewer service to each facility connected to the sewers during the execution of the Work to be performed. In the event that sewage backup occurs and enters dwellings or other structures due in any part to a failure of the bypass piping system, the Contractor shall be responsible for cleanup, repair, property damage costs, fines imposed by jurisdictional authorities, and all claims arising therefrom. All spills shall be contained and returned to the sewer system.

In the event the Regional Water Quality Control Board levies a fine on the District because of a sewage spill caused by the Contractor (directly or indirectly) due to lack of attention to procedures or other negligence, the Contractor shall be held responsible and liable for reimbursing OCSD for the entire amount of each fine imposed.

Contractor Submittals

Unless otherwise indicated, the following shall be submitted to the Engineer, for each in-line bypass or aboveground bypass installation, fifteen (15) days after receiving the Notice to Proceed, as specified herein:

- Plans showing proposed temporary handling of sewage flow procedures, routing and protection of bypass lines, containment areas, equipment location, schematic of pump set-up and discharge, and proposed sequencing.

- Shop drawings for the sewage bypass pipe material and fittings pipe repair kits and procedures, spill recovery mats, and video camera.
- Complete bypass pump system details, field verified and certified characteristic curves, documentation on electrical systems, controls, and instrumentation.
- Flow calculations for sizing pumps and piping, signed and stamped by an engineer Registered in the State of California.
- Spill Prevention, Control, and Countermeasure Plan as described herein, including a Contingency Plan containing actions to be taken in the event of a sewage spill.
- For all aboveground bypasses, the Contractor shall provide a map of the construction site indicating locations of the following:
 - 1) All storm drains in the area
 - 2) Sewer manholes in the area
 - 3) Bypass equipment
 - 4) Staging area / construction area.

2 PRODUCTS

Pumping Equipment

Pumps shall be engine-driven, variable-speed, self-priming non-clog sewage pumps. The Contractor shall use pumps of sufficient capacity to meet maximum flow within the pipe to prevent spills. All pumps shall be capable of cycling from 0 gpm to the required pump capacity.

The Contractor shall perform flow monitoring to verify sewage flows for pump sizing. All pumps considered for this bypass Work shall be capable of passing 3-inch sized solids.

Standby pumping equipment shall be at the site and connected to the system continuously during pumping to provide 100 percent standby pumping capacity. The Contractor shall provide sufficient manpower to continuously monitor and service the pumping equipment on a 24-hour basis while in operation, to activate standby equipment, and clean pumps due to ragging, if necessary. The Contractor-provided bypass system manpower shall be trained in pump operation and maintenance and be fully capable of operating all aspects of the bypass system.

Pumps shall be capable of running twenty four (24) hours per day as required to complete the Work.

All pumps and standby pumps shall be engine-driven and shall be critically-silenced for sound control in accordance with the applicable city's noise provisions.

The Contractor shall be responsible for traffic barricades and temporary chain-link fencing around bypass pumps. Sound attenuating acoustic blankets shall be installed on temporary chain-link fencing to provide an additional level of sound dampening over the critically-silenced pump enclosures.

Bypass Piping

Aboveground bypass piping shall consist of one temporary aboveground HDPE pipeline, DR17 minimum. Pipe shall be sized to handle maximum flow within the pipe.

The HDPE pipe shall be laid above ground and shall be provided with manufactured road crossings at each road or driveway. A ramp bypass shall be prefabricated for each size of ramp provided to allow removal and cleaning of the bypass ramp in the event of blockage. One spare road crossing of each size shall be stored on the project site for quick replacement of duty crossing if needed.

Manhole Level Sensors with Alarm

Each bypass suction wetwell or manhole shall be fitted with a liquid level sensor connected to an audible alarm and light. Level shall be set to indicate a pumping failure as early as possible.

Rubber Matting for Blocking of Storm Drain Inlets

Rubber matting shall be premium grade neoprene sheet, 1/8-inch thick minimum, 48 inches wide; 60 to 70 durometer.

3 EXECUTION

Spill Prevention, Control and Countermeasure Plan (SPCCP)

The Contractor shall prepare a Spill Prevention, Control, and Countermeasure Plan (SPCCP). The Plan shall include preventative measures to be taken to prevent a wastewater spill, and also actions to be taken in the event of an accidental wastewater spill. Maximum importance shall be placed on protecting spilled wastewater from reaching storm drains. The SPCCP shall contain any calculations required for sizing equipment. The Contractor shall submit for the Engineer's acceptance all duty and emergency equipment for containment,

cleanup, and repair of any spill. Specifics for each bypass installation shall include, but not be limited to, the following, as applicable:

- Pipe repair kits
- Spare inflatable pipe plugs
- Spare pipe sections, and other relevant equipment
- Spare valves
- Spare vehicle ramps
- Standby pumping truck(s)
- Secondary containment around duty and standby pump installations.

The SPCCP shall also contain the names and telephone numbers of at least three (3) Contractor's staff members on who can be contacted 24 hours per day by phone and brought on-site at any time to address on-site emergencies.

Vacuum Tanker Trucks

The Contractor shall provide reservation of two vacuum-capable tanker trucks and personnel. Such equipment shall be available to the project for on-site response within 30 minutes upon receiving a notice over 24 hours per day for the duration of the field work.

Protection of Storm Drains

The Contractor shall protect storm drains during construction. In the event of a spill, no sewage shall be allowed to flow into any storm drain. The storm drain inlets shall be blocked with rubber matting and sand bags. Rubber matting shall overlap storm drain inlets by a minimum of 24 inches on all sides. For inlets located in traffic areas, the grating may be removed, wrapped with rubber sheeting, and reinstalled to provide a barrier to the inlet.

Spill Report

In the event of a sewage spill(s), the Contractor shall obtain from the Engineer the up-to-date OCSD Collection System Problem Report form, fill it out and submit it with the associated photos to the Engineer for each spill.

Contact

In the event of a sewage spill(s), the Contractor shall immediately notify District's Plant 1 Control Center and provide the following preliminary information:

- Date and time of the spill
- Location of the spill
- Volume of the spill
- Did the spill enter the storm drain.

12.4.15 *DEWATERING*

The Contractor shall provide and maintain at all times during construction ample means and devices with which to promptly remove and properly dispose of all water from any source entering excavations or others parts of the Work.

No concrete footings or floors shall be laid in water nor shall water be allowed to rise over them until the concrete or mortar has set at least 8 hours. Water shall not be allowed to rise against unshored walls. There shall be dewatering operations continuously to protect the jobsite.

12.4.16 *TRENCH WIDTH*

Sewer trenches shall be excavated in such a manner as to produce a trench no less than 12 inches and not more than 16 inches in width over the largest outside diameter of pipe. Trench width shall be measured at a point 6 inches above top of pipe.

Where trench width exceeds the maximum specified above, overwidth bedding details shall be required.

All trenches shall be in compliance with the minimum requirements of OSHA at all times.

12.4.17 *TRENCH BACKFILL*

1 GENERAL

All trenches shall be backfilled after pipes, fittings and appurtenances have been installed. Native backfill material shall be free from all pavements, wood trash, rocks larger than 6 inches in any dimension, or other deleterious material. Imported backfill shall be free from organic or peat soils in addition to the above requirements. Trench shall be compacted to a minimum relative density of 90 percent as determined by Cal Trans Test No. "California 216 F" or Cal Trans 231. Note that the top 18 inches of trench compaction shall be compacted to 95-percent relative density. Requirements of the local agency having jurisdiction in public rights-of-way shall take precedence in all cases.

2 PUBLIC STREETS

Backfill and compaction in public streets, above the pipe zone, shall be in accordance with the requirements of the local agency having jurisdiction.

3 PRIVATE STREETS

Material shall be as specified above. The trench shall be compacted to within 18 inches of the pavement base in lifts not to exceed 12 inches. Consolidation may only be used in cases where the soil is sufficiently granular in nature to be self-

draining. Compaction within the 18 inches of the pavement base shall be compacted in lifts not to exceed 6 inches. Consolidation methods of compaction shall not be used in this zone. The trench shall be compacted to a minimum relative density of 90 percent. Compaction tests shall be taken at depths and locations as directed by the Inspector. The Developer or Contractor shall provide compaction testing by a certified testing laboratory approved by the Engineer.

4 NON-PAVED AREAS

Material shall be as specified above. Backfill from the pipe zone to the natural ground surface shall be compacted in lifts not to exceed 18 inches and to a minimum relative density of 90 percent. The Contractor shall dispose of excess material, off-site, in a legal manner.

12.4.18 HOUSE LATERALS

1 GENERAL

The Contractor shall install house laterals and wye or tee branch fittings of the size and location as indicated on the Plans. The Contractor shall not proceed with placement of the house laterals until such time as the surveyor has staked the laterals at sewer center and property lines.

No bends greater than one-eighth shall be used in the construction of house laterals within public right-of-way. Laterals shall be joined to wye branch fittings at the sewer main by the use of eighth bends positioned to obtain the desired lateral slope. All fittings or laterals that are to be left unconnected shall be plugged with a vitrified clay or neoprene stopper as specified herein.

2 DEPTH AND SLOPE OF LATERALS

Minimum cover over house laterals at the property line shall be 5 feet. Slope of house laterals shall be 1/4 inch per foot (0.02 ft/ft) minimum. In cases where property grades relative to the sewer are critical, the Engineer may approve a lesser slope.

3 LOCATION MARKING

The ends of all house laterals shall be marked as follows:

- In cases where laterals are to be connected to the dwelling unit during the same phase of construction, and where curb improvements are included, the Contractor shall mark each house lateral by chiseling the letter "S" 1-1/2 inches high on the top of the curb.

- In cases where laterals are not to be connected to the dwelling unit, the Contractor shall place a 2 x 4 treated redwood stake extending vertically from the end of the lateral to within 3 feet of finish grade. In addition, where curbs are to be constructed, the Contractor shall chisel the letter "S" on the top of the curb.

12.4.19 MANHOLES

1 GENERAL

Sewer manholes shall be constructed in accordance with the Standard Drawings and at the locations shown on the Plans. The manholes shall be constructed of precast concrete manhole units in accordance with the section entitled "Precast Manholes" herein and the related Standard Drawings. Manholes shall be built without steps. Manholes on piping over 12-inch nominal size shall be lined with PVC.

2 ON NEW SEWERS

The manhole base shall be poured in place against wood or sandbag forms with 650-WC-4000 Portland cement concrete. All wood forms shall be removed prior to slurry placement. The manhole stubs and sewer main shall be set before the concrete is placed and shall be rechecked for alignment and grade before the concrete has set. The various inlets and outlets to the manhole shall be located as indicated on the plans and as detailed in the Standard Drawings. All transitions shall be smooth and of the proper radius to give an uninterrupted transition of flow. The radius shall be not less than the inlet pipe radius. The concrete shall have a slump not greater than 3 inches. The concrete base may be shaped with a wood float and shall receive a hard steel trowel finish prior to the concrete setting. In the event additional mortar is required after initial set has taken place, the surface to receive the mortar shall be primed, and the mortar mixed with an approved adhesive in the amounts and proportions as recommended by the manufacturer and as directed by the Inspector in order to secure as chip-proof a result as possible. The bases shall be set a minimum of 12 hours before the manhole construction is continued. In certain critical situations, the time of setting may be reduced upon approval of the Engineer.

Manhole shafts shall be joined with a 1-1/2-inch square bead of plastic sealing compound in the joint groove toward the outside of the manhole and on the shoulder immediately above the first bead. The joint to the base shall have a third bead placed at the inward corner of the groove. Grade rings shall be joined with a minimum thickness of 1/2 inch of cement mortar to form a watertight and smooth joint. Any infiltration of ground water shall be stopped by a repair approved by the Engineer.

Whenever new manholes are constructed in unpaved areas, the manhole cover shall be set 18 inches above finish grade, or as directed by the Inspector.

In all cases during construction, the Contractor shall place 1/2-inch plywood inserts on the manhole shelf to prevent debris from entering the sewer in the event the manhole protection cover is disturbed.

3 ON EXISTING SEWERS

While excavating in the vicinity of the existing sewer, Contractor shall use extreme care to prevent damage to the sewer pipe. The base shall be poured in place against wood or sandbag forms with Class "A" 650-WC-4000 Portland cement concrete. Manhole stubs shall be provided on both sides of the main and shall be rechecked for alignment and grade before concrete has set. All wood shall be removed prior to placement of slurry. Manhole stubs shall be plugged with factory plugs, or brick and mortar for pipe over 21 inches, prior to connecting the incoming sewer. This plug shall not be removed until the offsite Work has been completed and the sewer cleaned, and with the approval of the Inspector.

Pipe saw cutting shall take place only under inspection by the District and only after the manhole and onsite sewer have been completed and cleaned. Sewer main sizes 12 inches and larger shall be sawcut to remove the top portion of the pipe. Care shall be taken to prevent cuttings from entering the existing sewer. The Contractor shall be required to have the sewer trunk balled and cleaned by an experienced sewer maintenance contractor if, in the opinion of the Inspector, excessive amount of cutting or debris has entered the sewer. Upon refusal of the Contractor to clean the District line immediately, the District staff will clean the line and the Contractor shall pay all expenses incurred by the District. All equipment and materials shall be securely fastened by a rope at all times while in a manhole.

After cut out, all rough edges shall be worked to produce a true and neat opening. The edges of the pipe shall then be filled and smoothed with mortar. The surface to receive mortar shall be primed and the mortar mixed with an approved adhesive in the amounts as recommended by the manufacturer and as directed by the Inspector. For PVC-lined manholes, weld the manhole liner to the PVC pipe liner.

The bases shall be set a minimum of 12 hours before the manhole shafting is set. In certain critical situations where traffic is a problem in the opinion of the Inspector, the time of setting may be reduced to 6 hours provided a 2-percent mix of calcium chloride is added to the concrete.

Manhole shafting shall be as specified under the section entitled "On New Sewers" herein.

Whenever new manholes are constructed in unpaved areas, the manhole cover shall be set 18 inches above finish grade or as directed by the Inspector.

Whenever grading or paving operations follow pipe removal, the Contractor shall place 1/2-inch plywood inserts on the manhole shelf to prevent debris from entering the sewer in the event the manhole protective cover is disturbed.

12.4.20 PRESSURE SEWERS

1 GENERAL

All pressure sewers shall be ductile iron pipe, HDPE, or fusible PVC, unless otherwise agreed to by OCSD in writing.

Ductile iron pipe shall be in accordance with the section entitled "Ductile Iron Pipe" herein. Installation shall be in accordance with the latest edition of the Ductile Iron Pipe Research Association's (DIPRA) *Thrust Restraint Design for Ductile Iron Pipe*, AWWA Manual M41 *Ductile Iron Pipe and Fittings*, and District's Master Specifications.

HDPE shall be AWWA C906 with a minimum DR of 17.

Fusible PVC shall be AWWA C900 or C905 by Underground Solution Incorporated, or equal, with a pressure rating acceptable to OCSD.

2 TRENCHING AND BEDDING

Trenches shall be even and straight so that the pipe is centered. Trench width shall not exceed 24 inches plus the nominal pipe size. Rock or unyielding subgrade shall be removed to 12 inches below the pipe bottom. Bedding material shall be clean sand in dry soil conditions and, for DI and HDPE pipe, 3/4 -inch crushed base rock in wet soil conditions, placed a minimum of 6 inches below the pipe's bottom and to 6 inches above top of pipe. For fPVC pipe, the bedding shall be clean sand surrounded by geofabric. The bedding shall be even so that the pipe is uniformly supported over the entire length of the pipe. At each joint, the bedding shall be recessed in such a manner as to relieve the joint of the pipe of all loads. Backfill and compaction shall be as specified in the section entitled "Trench Backfill" herein.

3 VALVES

The Engineer will determine if and where valves are required; and, if required, the Engineer will specify the type thereof.

4 THRUST RESISTANCE

Thrust resistance shall be provided at all changes in pipe direction. Thrust resistance shall be designed in accordance with the latest DIPRA specifications and installed per manufacturer's instructions. All thrust restraint shall be corrosion-resistant in accordance with the latest DIPRA specifications.

Thrust resistance shall be achieved by one of the two following methods:

- Restrained joints shall be the preferred method of thrust restraint. Restrained joints shall be designed appropriately for the pipe size,

internal pressure, depth of cover, soil characteristics, and potential pipe encasement specific to each site, in accordance with the most recent edition of DIPRA's Thrust Restraint Design for Ductile Iron Pipe.

- Thrust blocks shall be permitted only upon approval by the Engineer based on consideration of available space and adjacent facilities. Thrust block size shall be restricted to the minimum required size in accordance with the most recent edition of DIPRA specifications. Thrust blocks shall be constructed of reinforced Class "A" concrete placed against undisturbed soil. Bearing surface against undisturbed soil for 4-inch and 6-inch pipe shall have a minimum area of 3 square feet, or as shown on the Plans.

12.5 MATERIALS

12.5.1 GENERAL

All materials not conforming to the requirements specified herein shall be considered defective and all such materials, whether in place or not, shall be rejected and shall be removed immediately from the site of the work unless otherwise permitted by the Engineer. No rejected material, the defects of which have been subsequently corrected, shall be used until approved in writing by the Engineer.

12.5.2 VITRIFIED CLAY PIPE

1 GENERAL

All vitrified clay pipe and fittings shall be of one class designated extra strength, of the best quality, vitrified, homogenous in structure, thoroughly burned throughout their entire thickness, impervious to moisture, sound and free from cracks, checks, blisters, broken extremities or other imperfections, and shall give a metallic ring when struck with a hammer. Pipe shall be bell and spigot pipe or other approved joining method unless otherwise specified. All pipe and special fittings manufacture shall comply with the applicable sections of the OCSD Master Specifications.

2 IN-PLANT TESTING

Testing shall be in accordance with the applicable section of the OCSD Master Specifications. In lieu of the tests being witnessed by a certified testing laboratory approved by the Engineer for pipe sizes 15 inches and smaller, the Contractor may furnish the Districts a letter from the manufacturer stating that all prescribed tests have been made and the pipe meets all requirements of the Master Specification.

In pipe sizes greater than 15-inch diameter, a certified testing laboratory approved by the Engineer shall be employed by the Contractor for specified testing.

3 CAUSE FOR REJECTION

The following imperfections in a pipe or special fitting shall be considered injurious and cause for rejection without consideration of the test results submitted as specified above:

Cracked Pipe

A single crack in the barrel of the pipe, extending through the entire thickness, regardless of the length of such crack; a single crack which extends through one-fifth of the barrel thickness and is over 3-inch long; any surface fire crack which is more than 1/32-inch wide at its widest point.

Surface Imperfections

Surface imperfections such as lumps, blisters, pits or flakes on the interior surface of a pipe or fitting.

Socket Out-of-Round

Bore or socket of the pipe that varies from a true circle more than 3 percent of its nominal diameter.

Straight Pipe Fitting

The pipe fitting designated to be straight, but deviates from a straight line more than 1/8-inch per lineal foot. The deviation shall be measured from a straight edge at a point midway between the ends of the pipe.

Broken Pipe

A joint of pipe with a piece broken from either the socket or spigot end.

Foreign Matter Fused to the Pipe

Pipe joints that have tramp clays, grog or other foreign matter fused permanently to the exterior or interior surface of the pipe or fittings.

General Soundness of Pipe and Joints

The pipe that does not give a metallic ring when struck with a hammer where joint of pipe is placed in a vertical position.

4 JOINTS

All vitrified clay pipe and fittings shall be furnished with bell and spigot Type G compression joint or where plain end pipe is to be used Type C joint. For pipe sizes of 12 inches and smaller, Type D joint may be used.

Type "C" Joints (Mortar Sealed Rubber Sleeve Couplings for Plain End Clay Pipe)

Each coupling shall consist of a circular rubber sleeve, two stainless steel compressing bands, and optional pre-fabricated housing to form the required mortar seal of the coupling.

Each coupling shall bear the manufacturer's brand name or trademark.

The housing to form the mortar seal shall be shaped to provide the minimum thickness of mortar cover over the coupling and specified in the following table.

Pipe Diameter		Thickness	
(inch)	(mm)	(inch)	(mm)
4	(102)	3 / 4	(19)
6	(152)	3 / 4	(19)
8	(203)	1	(25)
10	(254)	1	(25)
12	(305)	1-1 / 2	(38)

(larger sizes as specified on the Plans)

The circular rubber sleeve shall have a projecting rib to act as a cushion between the abutting ends of the pipes or fittings. The sleeve shall be made of virgin rubber compounded with suitable antioxidants formulated so as to resist acids, alkalies, solvents, and greases encountered in domestic or industrial waste sewage.

When tested in accordance with ASTM D 412, the material shall have a tensile strength of not less than 1200 tested psi and in elongation of not less than 400 percent. When tested in accordance with ASTM D 395, Method B, the material shall have a compression set at constant deflection of not more than 35 percent of the original deflection. The tensile strength and percentage of elongation shall be reduced not more than 25 percent and the compression set increased not more than 5 percent when subject to the accelerated aging test in ASTM D 572 for 24 hours.

The stainless steel compressing bands and tightening devices shall be fabricated from ASTM Type 300 stainless steel and shall be capable of producing 35 percent compression in the sleeve when tightened in place on the joint. Mortar consisting of one part Portland Cement and three parts sand shall be used for

sealing in the rubber sleeve coupling. Water shall be added to the mortar mixture to produce a workable grout mortar.

The assembled pipe joints, without mortar cover shall be tested in the laboratory and shall not leak when subject to an internal hydrostatic pressure of 10 psi for a period of 5 minutes or when the joint is deflected 2 degrees during the test.

Type “D” Joints (Rubber Sleeve Coupling) with Shear Ring for Plain End Clay Pipe)

The coupling shall consist of a circular rubber sleeve of natural or synthetic rubber or rubber-like material, two stainless steel bands with suitable tightening devices and corrosion resistant shear ring. The sleeve shall be resistant to chemicals and bacteria, and the joint shall meet all the requirements of ASTM C 425, except that the bands shall be made of stainless steel only.

Type “G” Joints (Polyurethane)

General:

The type “G” Joint shall consist of polyurethane elastomer sealing components, one bonded to the outside of the spigot and the other bonded to the inside of the socket. The sealing components shall be shaped, sized, bonded, and cured to uniform hardness so as to form a tight seal of the joint when assembled. The sealing components shall resist attack by bacteria and chemicals or combinations of chemicals normally present in domestic or industrial sewage.

The configuration of the jointing system determines the necessary physical properties of the polyurethane joint material. The columns of values in the table below represent properties of polyurethanes which, in conjunction with specific joint configurations, will provide acceptable jointing systems.

Polyurethane Sealing Components:

The polyurethane sealing components material shall comply with the requirements described in this subsection. The number of samples to be tested shall be designated by the Engineer.

Prior to testing, polyurethane test specimens shall be conditioned in a mechanical convection oven for 7 days at 110 + 5 degrees F (43 + 3 degrees C and cooled in a desiccator for 3 hours at 75 + 5 degrees F (24 + 3 degrees C).

Polyurethane material is acceptable for a jointing system when properties are in conformance with either column of values listed in the following table:

Property	Values		Test Method and Conditions
Tensile strength, psi (kPa) min.	350 (240)	600 (4140)	ASTM D 412 DIE C, 75 ± 5 F (24 ± 3 C)
Elongation, % min.	70	70	(Same as above)
Compression set, percent Max.	3	3	ASTM D 395, Method B, 24 hours, 75 ± 5 F (24 ± 3 C)
Shore durometer	Not less than value designated for the joint design by the manufacturer		ASTM D 2240, Type A, 5-second reading, 32 to 80 F (0 to 27 C)
Water Absorption, percent max. (Wt gain)	3.5	3.5	ASTM D 570, after immersion for 28 days at 75 ± 5 F (24 ± 3 C)
Volatile loss, percent max. (Weight loss)	1	1	After 28 days in mechanical convection oven at 150 ± 3 F (66 ± 2 C)
Adhesive strength, psi (kPa) min.			
Original	350 (240)	350 (2410)	Before immersion in accordance with Note 1
Final	250 (1720)	250 (1720)	After immersion in water at 75 ± 5 F (24 ± 3 C) in accordance with Note 1
Chemical resistance (see Notes 2 & 4)			
Weight changes, percent max.	1.5	1.5	After exposure to each of the chemical environments for 112 days as described in Notes 2 & 4
Tensile strength,	260 (1790)	450 (3100)	

Property	Values		Test Method and Conditions
Psi (kPa) min.			
Shore durometer, Change max.	± 15	± 15	
Compression set, percent max.	5	5	
Bacteriological resistance (see Notes 3 and 4)			
Weight change	2	2	After exposure to bacteriological environment for 112 days as described in Notes 3 & 4
Tensile strength, psi (kPa) min.	290 (2000)	500 (3450)	
Shore durometer			
Before reconditioning, Loss max.	15	15	
After reconditioning, Change max.	5	5	
Compression set			
Before reconditioning, percent max.	3	3	
After reconditioning, percent max.	3	3	

NOTES:

1. Adhesion test specimens shall be clay blocks 1/2-inch (13-mm) thick and 1-inch (25-mm) square of the same composition of materials and fired at same vitrifying temperatures as sewer pipe.

The clay block shall be placed flat in the center of a mold 7-inch (178-mm) long, 1-inch (25-mm) wide, and 1/2-inch (13-mm) deep. The edges of the clay block at right angles to the longitudinal axis of the form shall be coated with the adhesive and the form on each side of the block shall be filled to a depth of approximately 1/4-inch (6-mm) with the sealing component compound. Curing of this test specimen shall simulate the curing process at the pipe manufacturing plant.

At the end of the immersion period, samples shall be removed, surface dried, and immediately pulled in tension at the rate of 20 inches (508 mm) per minute to determine the final tensile strength of the bonded interfaces. The specimens retained for controls shall be pulled at the same time to determine the original tensile strength of the bonded interface.

2. Exposure environments for chemical resistance tests are as follows:

<u>Chemical</u>	<u>% Concentration</u>
Sulfuric Acid	20*
Ammonium Hydroxide	5*
Sodium Hydroxide	5* (Buffered to pH 10 with Sodium bicarbonate)
Ferric Chloride	1*
Nitric Acid	1

*Volumetric % of concentrated C.P. grade reagents

At the end of the exposure period, specimens shall be reconditioned before testing by the same method described above for conditioning.

3. The bacteriological resistance immersion test solution shall be prepared with a 5-day BOD of not less than 700 ppm maintained under anaerobic conditions at 75 + 5 degrees F (24 + 3 degrees C) for the duration of the test. At the end of the exposure period, test specimens shall be washed and then reconditioned before testing by the same method described above for reconditioning.

4. During the 112-day exposure period interim tests shall be performed at 28-day intervals and if failure occurs, testing shall be terminated and the sample shall be considered as failing the entire test.

12.5.3 REINFORCED CONCRETE PIPE

All reinforced concrete pipe to be installed is to be identified by the internal diameter in inches, type and strength and designation.

1 GENERAL

Pipe shall be manufactured only in presence of the Inspector. No material shall be used in the manufacture of the pipe other than cement, sand, rock, water, and reinforcing steel (also hard drawn wire if non-cylinder prestressed pipe is to be furnished), except as otherwise indicated on the Plans, in the Project Specifications, or permitted in writing by the Engineer. The materials used shall conform to the provisions of the various sections of the State Specifications which set the requirements for such materials.

Before starting manufacture of pipe, the Contractor shall submit to the Engineer, for his review, detailed shop drawings of the pipe, joints, reinforcement cage assemblies, pipe specials, and the pipe laying diagrams. If non-cylinder prestressed pipe is to be furnished, the Contractor shall also submit to the Engineer, for his review, complete design calculations for each size and D-load to be furnished under this alternative.

The laying diagram shall show the location, length, design designation, and number designation of each pipe section and pipe special to be furnished and installed. Also, station and elevation of pipe invert at all changes in grade, all data on curves and bends for both horizontal and vertical alignment shall be shown. Sockets and spigots shall be free from any deleterious substances or condition that might prevent a satisfactory mortar bond at the joints.

2 VINYL PLASTIC LINER

Vinyl plastic liner shall be white in color and be cast into all pipe at the time of manufacture in accordance with the Standard Specifications for Public Works Construction (Greenbook) specifications for vinyl plastic liner. Unless otherwise directed, the pipe shall be fully lined (360-degrees), unless otherwise noted.

3 MATERIALS

Except when otherwise permitted by the Engineer, no materials shall be used in manufacturing of the pipe other than water, Type II Portland cement as specified in ASTM C 150, mineral aggregates and low alkali steel conforming to ASTM C 76, and for noncylinder prestressed pipe, prestressing wire conforming to ASTM A 648 in sizes No. 8, No. 6, 1 /4 inch, and 5 /16 inch.

The aggregates shall be so graded, proportioned, and thoroughly mixed in a batch mixer to produce a homogeneous concrete mixture of such quality that the pipe will conform to the test and design requirements of that specified.

A set of at least four standard test cylinders shall be taken from each day's pour of the mixed concrete for pipe. Test cylinders shall be made in conformance with ASTM C 31. The curing of the test cylinders shall be in conformity with the curing of the pipe.

All test cylinders shall be tested in conformance with ASTM C 39 by an approved testing laboratory at the expense of the manufacturer, unless the manufacturer has approved testing facilities at the site of the work. In such event, the test shall be made by and at the expense of the manufacturer in the presence of the Engineer, or the certified test reports may be submitted by the manufacturer.

4 SIZES AND DIMENSIONAL TOLERANCES

Pipe shall have a minimum nominal length of 8 feet, except as otherwise specified or required for special purposes such as curves or closures. Unless

otherwise provided on the Plans or in the project Specifications, the maximum nominal length of pipe permitted shall be 20 feet.

Pipe shall be round and true and shall have smooth and dense finished surfaces. The internal diameter of any portion of each piece of pipe shall not vary more than + 1 percent, but in no case shall exceed 3 / 8 inch, from the nominal diameter. The wall thickness shall not be less than that shown in the design by more than 5 percent, but in no case shall exceed 3/16 inch. A wall thickness more than that required in the design shall not be cause for rejection, as long as the reinforcement is properly placed.

Reinforcement steel shall be accurately placed in the concrete wall of the pipe. The placement of all steel shall not vary from the position in the pipe wall shown on the drawings by more than + 1 / 4 inch from the nominal shown on the drawings. In no case shall the cover over any reinforcement be less than 1 inch.

Variations in laying lengths of two opposite sides of pipe shall not be more than 1/8 inch per foot of diameter with a maximum of 3/8 inch in any length of pipe except where beveled pipe is used. The underrun in length of a section of pipe shall not be more than 1/8 inch per foot with a maximum of 1/2 inch in any length of pipe.

5 REINFORCEMENT

The reinforcement shall be fabricated as a rigid cage of bars or wire. Transverse reinforcement shall be fabricated either as complete hoops, welded or lapped, or as a continuous helix. If the transverse reinforcement is formed as a cylinder or elliptical helix, both ends of the cage shall be finished off as a complete hoop. Elliptical cages may be wound on an elliptical drum or deformed from a circular cage to the required elliptical dimensions. The location of the minor axis of elliptical reinforcement shall be clearly indicated. A letter "T" shall be painted or stamped on the inside of the pipe to indicate the minor axis so that the pipe can be laid with the minor axis vertical.

Splices shall be either welded or lapped and tightly wired. Either lap or butt welds may be used, but the weld shall develop the full strength of the bar and, when required by the Engineer, the Contractor shall submit for testing, samples of welds proposed for use. The lap of unwelded splices shall extend 30 diameters when bars or rods are being used for reinforcement and 40 diameters when wire is being used.

Suitable devices shall be used to hold the cage of reinforcement in its elliptical or circular shape and to maintain the cage in place within the forms during the placing and consolidating of the concrete. Supports between the reinforcement and the forms that are to be exposed in the finished pipe shall be made of stainless steel.

Longitudinal reinforcement shall be in sufficient amount to provide a rigid cage of reinforcement. Where the pipe design is shown on the Plan, the type, the extent, and positioning of the longitudinal steel indicated shall be considered a minimum

requirement. Whether pipe details are shown on the Plans or not, the Contractor shall be responsible for providing enough longitudinal steel to provide a cage sufficiently rigid to retain its shape and position in the forms during the manufacturing process.

Each pipe shall have a minimum longitudinal reinforcement equivalent to 1/2-inch diameter steel rods at a maximum spacing of 18 inches center to center. Also, such reinforcement shall provide at least a ratio of 0.0020 reinforcement area to gross concrete area (cross-section). Where the pipe joint construction requires the use of a bell, the minimum specified number of bars shall be continued into the bell. Where two cages are used, the longitudinal reinforcement shall be divided approximately equally between the two cages, and only the longitudinal bars on the outer cage need to extend into the bell.

The reinforcing steel shall be placed in the wall of the pipe in such a manner that the end hoops of the transverse reinforcement and the ends of the longitudinal reinforcement shall not be more than 1 inch + 1/4 inch from the extreme end concrete faces of the pipe.

6 NON-CYLINDER PRESTRESSED PIPE

Where very high D-loads are required, as an alternate to bar-reinforced concrete pipe, the Contractor may furnish non-cylinder prestressed concrete pipe. Non-cylinder prestressed pipe shall be designed for the specified D-loads. No prestressed pipe shall be provided without the approval of the Engineer.

Non-cylinder prestressed pipe shall contain a reinforcement cage with sufficient hoops or coils to provide a rigid cage for proper positioning of the longitudinals and joint rings, but the area of circumferential steel shall not be less than 0.002 times the cross-sectional area of the pipe wall, and spacing of circumferential hoops or coils shall not exceed 12 inches.

Longitudinal reinforcement for non-cylinder prestressed pipe shall comply with the longitudinal requirements for bar-reinforced concrete pipe.

Centerline spacing of prestress wires shall not exceed 1-1/2 inches and shall provide a minimum clear space of 3/16 inch between adjacent coils.

7 JOINTS

The ends of the pipe shall be so formed that, when the pipes are laid together and the joints cemented, they shall make a continuous and uniform line of pipe with a smooth and regular interior surface.

The Contractor shall have the option of furnishing one of two types of joints: (1) the lock joints, (2) a concrete bell and the spigot type where a gasket shall be confined in a contained groove. Each joint shall contain a neoprene ring gasket that shall be the sole element depended upon for water-tightness of the joint. The gasket shall be of circular cross section unless otherwise approved by the

Engineer. The length and cross-sectional diameter of the gasket, the annular space provided for the gasket, and all other joint details shall be such as to produced a watertight joint that will not leak when pulled 1 inch from normal closure for full circumference. The slope of the longitudinal gasket contact surfaces of the joint with respect to the longitudinal axis of the pipe shall not exceed 2 degrees.

Where double mitered pipe joint sections are used to deflect the pipe through an angle as indicated on the Plans, the section shall be completely plant manufactured and not constructed in the field.

The Contractor shall submit shop drawings to the Engineer showing the details of the pipe joints the Contractor proposes to use. No pipe shall be manufactured until such shop drawings have been reviewed and approved by the Engineer. Such review by the Engineer shall in no way relieve the Contractor from the leakage or infiltration tolerances as specified herein. Failure of the longitudinal concrete surfaces of a joint to meet the dimensional tolerances shown on the Plans and/or the shop drawings shall be cause for rejection.

When lock joint is used, all exposed steel in the joint ring shall be coated with one coat of alkyd rust inhibitive primer. Acceptable products are Amercoat No. 25 primer, Protexzol 178 quick-drying red primer, or equal.

8 RUBBER GASKETS

Gaskets for Concrete Pipe: Unless otherwise specified, gaskets shall be manufactured from a synthetic elastomer conforming to SSPWC section 208-3.

The Contractor shall submit for review details of the shape and size of the gaskets the Contractor proposes to furnish. The Contractor shall also submit test reports showing the physical properties of the materials used in the manufacture of the gaskets, and demonstrating compliance with the specifications.

12.5.4 DUCTILE IRON PIPE

1 GENERAL

All ductile iron pipe shall conform to the requirements of AWWA C151/and shall be fusion bonded epoxy lined. Buried pipe shall be provided with anodic protection, joint bonding, and test stations. Exposed pipe shall be coated with a two-part amine cured epoxy, minimum 10 mils dry film thickness, topped with a polyurethane color coat, gray in color. Buried pipe shall be minimum Class 150 pressure class. Exposed pipe shall be minimum Class 53 thickness class.

2 JOINTS

Joint types shall be as follows:

Buried Pipe

- Use restrained joints where thrust restraint is needed rather than thrust blocks.
- Rubber gasket slip-on shall conform to AWWA C111/A21.11.
- Mechanical joint fittings shall be in accordance with AWWA C111/A21.11.
- Flexible couplings, where called for on the plans, shall be cast or ductile iron sleeve type as manufactured by Smith-Blair or approved equal.
- .

Above Grade Pipe

Flange fittings shall conform to ANSI B16.1. Bolts shall conform to ANSI B16.1, except that flanges shall have Type 316 stainless steel bolts and nuts except in air-conditioned spaces.

12.5.5 PRECAST MANHOLES

1 GENERAL

All precast manhole shafting, cones and flat tops shall be free from cracks, chips, surface imperfections and shall be capable of producing a watertight unit. Manhole shafting shall not be installed with steps.

2 UNLINED MANHOLES

Precast manholes shall conform to size, shape, form, and details shown on the Standard Drawings. Concrete for precast units shall be Class "D" concrete. The precast shafting and cones shall meet the strength requirements for ASTM C478 "Standard Specification for Precast Reinforced Concrete Manhole Sections". Design and manufacturing shall be based on H-20 loading.

3 LINED MANHOLES

Manholes designated as "lined" shall be lined with P.V.C. cast in place liner. All materials and installation shall be in accordance with the notes and details shown on Standard Drawing S-050.

12.5.6 GRADE RINGS

Grade rings shall be the size and quantity as indicated in the Standard Drawings. Grade rings shall be free from cracks, chips or excessive roughness as determined by the Inspector.

Individual concrete grade rings for extensions shall be a maximum of 6 inches high and shall be approved by the Engineer before installation. Total height of stacked grade rings shall be limited to a maximum of 12 inches.

12.5.7 MANHOLE FRAME AND COVER

Manhole frame and cover sets shall be of the types and size indicated in the Standard Drawings unless otherwise indicated on the Plans. Standard manhole frame and cover shall be Model No. A-1254-6 for 24-inch diameter or A-1251-6 for 36-inch diameter as manufactured by Alhambra Foundry Co., or approved equal.

Manhole frame and cover sets installed in an intersection shall be bolted, Model No. A-1251B-6 as manufactured by Alhambra Foundry Co., Ltd., or approved equal.

All manhole frame and cover sets shall have the facility identification on the underside of lid and on frame. All castings shall comply with ASTM A48 "Standard Specification for Gray Iron Castings", Class 35 B cast iron.

Castings for frame and cover sets shall be designed for H-20 loadings. Before leaving the foundry, all castings shall be thoroughly cleaned and subjected to a hammer inspection, after which they shall be painted with a 60-mil minimum thickness of coal-tar epoxy. Covers shall have reinforced gussets on the underside.

Each cover shall be ground or otherwise finished so that it will fit in its frame without rocking. Frames and covers shall be match-marked in sets before shipping to site.

New manholes shall be built with covers set at 12 to 16 inches from the top of the cone.

12.5.8 EPOXY RESIN

All saddle connections and approved repair work to District sewer mains shall be accomplished with one of the following epoxy resins:

EPIBOND 157 as manufactured by Furane Plastics Incorporated, 5121 San Fernando Road West, Los Angeles, Ca;

WR633 A & B as manufactured by Wyndham Chemicals Incorporated, 10640 South Painter Avenue, Santa Fe Springs, Ca;

EPON 828 as manufactured by the Shell Chemical Corporation.

The epoxy resin shall be used in strict accordance with the manufacturer's specifications.

12.5.9 PORTLAND CEMENT CONCRETE

1 GENERAL

All Portland cement concrete shall conform to the requirements of ASTM C150 and shall be Type II, III or V.

2 TYPES

- Type II Standard ASTM Designation 15.
- Type III High Early Strength Type.
- Type V Sulfate Resistant Cement Type.

3 CLASS OF CONCRETE

	A	B	C	D
Compressive strength at 28 days (psi)	3500	3250	2500	4500
Cement Factor-Minimum (Sacks/cu. Yd.)	6.0	5.5	4.5	7.0
Water Cement Ratio-Max. (gallons/sacks)	6.0	6.5	7.0	5.6

4 ADMIXTURES

No admixtures shall be used without written consent of the Engineer. Calcium Chloride, if approved, shall be used to a maximum dosage of 2 pounds per 100 lbs.

12.6 TESTING

12.6.1 GRAVITY SEWERS

1 AIR TESTING

All sewers shall be air-tested. Testing shall take place only after certification that the compaction requirements and sewer cleaning requirements have been met.

Any recompaction over the sewer or repair of the sewer shall invalidate previous testing in the section of pipe involved.

Each section of pipe between two successive manholes shall be tested by plugging all pipe outlets with suitable test plugs. Air shall be slowly added until the internal pressure is raised to 4.0 psig. The compressor used to add air shall have a pressure relief valve set at 5 psig to assure that at no time the pressure becomes greater than 5 psig. The internal pressure of 4 psig shall be maintained for at least three minutes to allow air temperature to stabilize. After the three minute stabilization period, the air supply shall be disconnected and the pressure allowed to decrease to 3.5 psig. The time required for the air pressure to drop from 3.5 psig to 2.5 psig shall be measured and compared to the times shown below:

Pipe Size (Inch)	Time In (Minute)
8	4
10	5
12	6
15	7
18	9
21	10
24	11
Over 24	See State Specifications

If the pressure drop from 3.5 psig to 2.5 psig occurs in less time than the above values, the test shall be deemed failed and the pipe shall be repaired and, if necessary, replaced or relaid until the joints and the pipe hold air under this test.

2 CLOSED CIRCUIT TELEVISION (CCTV) VIDEO INSPECTION

The Design Engineer working for the District or consulting engineer under contract with the District for performing the design of a new or refurbished District gravity sewer is responsible for scheduling a closed circuit television (CCTV) video inspection of the appropriate existing District gravity sewer serving the sewer shed for which a new or refurbished gravity sewer will serve during the preliminary design phase or early in the final design phase of the work. The Design Engineer or consulting engineer will thoroughly research and identify all local and District trunk sewers to properly establish the sewer shed boundaries for any given job or portion of the District sewerage system.

All District local, sub-trunk and trunk sewers involved with existing sewage flow to be conveyed by the new sewer or refurbished sewer under the design job will be CCTV video inspected as part of the design. The Design Engineer or consulting engineer will collect or identify all appropriate pages or plans of the actual District

“record drawing” or “as-built” plans representing all sections of existing sewer pipelines to be CCTV video inspected.

The Design Engineer or consulting engineer shall give the District staff person responsible for coordinating the design work a minimum of fourteen (14) calendar days advance notification for the DISTRICT to properly schedule the desired CCTV video inspection. The DISTRICT O&M Department will physically arrange for and oversee one of the DISTRICT contracted CCTV video inspection crews to do the work of performing the CCTV video inspection inside of the appropriately identified DISTRICT gravity sewers. The DISTRICT will complete the CCTV video inspection in accordance with the latest DISTRICT and NASSCO Pipeline Assessment and Certification Program (PACP) standards. The DISTRICT will share the results of the CCTV video inspection with the Design Engineer or consulting engineer by means of either electronic data or physical submission which may include a DVD disk, a Compact (CD) disk, or a VHS video tape and an accompanying written report.

The Design Engineer or the consulting engineer will verify that the CCTV video inspection performed by the DISTRICT adequately identifies the appropriate NASSCO PCAP requirements for pipeline deficiencies in the existing DISTRICT sewer pipeline which has been identified by the Design Engineer or the consulting engineer. In addition, the Design Engineer or the consulting engineer shall properly identify by reviewing the CCTV video inspection media and accompanying report all incoming connections, house or business laterals, or other local or DISTRICT sewer connections, all manholes, and any junction or diversion structures in any section of the existing DISTRICT pipeline shown in the CCTV video inspection media. The Design Engineer or consulting engineer shall be responsible for documenting the condition assessment and location of all pipeline sections, connections and structures associated with the identified existing DISTRICT sewers and properly use that information in the design of any new or refurbished DISTRICT sewer.

The Contractor is responsible for scheduling a closed circuit television (CCTV) video inspection with the DISTRICT for all sections of sanitary sewer pipe installed by the Contractor on the job after the pipe has been installed, backfilled and compacted to grade, tested for leakage, manholes raised to grade, and cleaned, but prior to the final resurfacing of the street or surface directly over the pipe.

The pipe shall be CCTV video inspected involving a CCTV video process by a DISTRICT contracted CCTV video inspection crew (not by the Contractor), subject to a seven (7) calendar day minimum advance notification to the DISTRICT by the Contractor such that the pipe is or will be ready for CCTV video inspection on the scheduled advance date. The Contractor must have properly installed, prepared, tested and cleaned the pipe in accordance with DISTRICT standards. The Contractor must allow the DISTRICT contracted CCTV video inspection crew and equipment proper access to each manhole on the job to do the video inspection. The DISTRICT will complete the CCTV video inspection in accordance with the latest DISTRICT and NASSCO Pipeline Assessment and Certification Program (PACP) standards. The DISTRICT will share the results of

the CCTV video inspection with the Contractor by means of either electronic data or physical submission which may include a DVD disk, a Compact (CD) disk, or a VHS video tape and an accompanying written report.

The Contractor and/or the DISTRICT will verify that the pipe installation by the Contractor meets NASSCO PCAP requirements and is acceptable to the DISTRICT. Should the CCTV video inspection indicate any faulty or unacceptable (to the DISTRICT) pipe installation, the Contractor shall make the necessary repairs or replacements satisfactory to the DISTRICT at the Contractor's expense by a method acceptable to the DISTRICT/Engineer. Repaired or replaced pipe and/or pipe segments shall be retested and cleaned by the Contractor, and be re-inspected by the DISTRICT provided CCTV video inspection crew, to the same standards that are required from before, but only after the Contractor has satisfied the DISTRICT that the pipe is ready for inspection and the date for re-inspection has been scheduled by the Contractor by a seven (7) day minimum advance notification to the DISTRICT.

All costs for scheduling, preparing for inspection, testing, retesting, installing, reinstalling, repairing, cleaning, re-cleaning or other administrative costs, delays or activities by the Contractor relating to the pipe shall be provided for and paid by the Contractor at no additional cost to the DISTRICT, until final acceptance of the pipe by the DISTRICT is achieved.

12.6.2 PRESSURE SEWERS

All pressure sewers and piping shall be hydrostatically tested. Testing shall take place only after approved thrust blocks and tie downs have been placed and a minimum of three feet of backfill compacted over the pipe.

Test shall be conducted by adding water to the pipe slowly venting all air. After the pipe is filled with water, more water shall be added by means of a hand pump or suitable means to a pressure of 1.5 times the manufacturer's rated pressure of the pipe. The test pressure shall be maintained for a period of two hours at which time the test plug shall be removed and the pipe again filled with water. The amount of water added to the system after testing shall be measured and compared with the recommended allowable leakage per 1000 feet of pipe as shown in the Ductile Iron Pipe Research Association's (DIPRA) *Installation guide for Ductile Iron Pipe* and AWWA Manual M41 *Ductile Iron Pipe and Fittings*.

If the leakage is in excess of the allowable quantity indicated above, the pipe shall be repaired and, if necessary, replaced or relaid and retested.

12.6.3 MANHOLES

All manholes on new sewers shall be vacuum-tested per ASTM C1244 "Standard Test Method for Concrete Manholes by the Negative Air Pressure (Vacuum) Test Prior to Backfill". Manholes shall be watertight. All leaks shall be repaired as determined by the Engineer.

The manhole, if pressure tested, shall be filled with water to an elevation one foot below the start of the cone section, but to a maximum depth of 20 feet. The water shall stand in the manhole for a minimum of one hour to allow the concrete to reach maximum absorption. After one hour, the Contractor shall refill the manhole to the original depth and the drop in water surface shall be recorded after a period of two minutes for each foot of water depth. The maximum allowable drop in water surface for the period of testing shall be 1/2-inch for each 15 minutes of testing. Repairs shall be made as directed by the Engineer whenever leakage exceeds the limits indicated above. All infiltration shall be stopped prior to vacuum or pressure testing. All joints shall be exposed prior to testing. PVC joints shall be welded post testing, probed with a putty knife, and spark tested by the Contractor in the presence of the Engineer.

12.7 SAFETY

12.7.1 EXCAVATIONS

The Contractor shall comply with all safety ordinances and orders and shall be solely responsible for the safety conditions of the Work.

The Contractors shall submit a detail showing the design or shoring; bracing sloping or other provisions to be made for worker protection from the hazards of caving ground during the excavation of any trench 5 feet or more in depth.

The plan submitted shall be stamped and signed by a Civil or Structural Engineer Registered in the State of California to certify that the plan complies with all OSHA.

The Inspector will not inspect trenches which do not conform to OSHA trench safety standards.

12.7.2 CONFINED SPACE OPERATION

No entry into District's facilities shall take place without first checking for unsafe atmosphere conditions and, if found safe, entry shall be made only with the use of adequate air blowers and safety harnesses attended by a minimum of two men outside the facility. Proper air monitoring shall be in use at all time to monitor for L.E.L., H2S and oxygen deficiency before and during performance of work.

12.7.3 TRAFFIC CONTROL

Prior to undertaking the work, traffic control plans shall be submitted to the Agency having jurisdiction of the street for approval. A copy of the plans, the approved permit, and requirement therefore shall be provided to the Engineer.

In no case shall the traffic control be less than that required by the latest WATCH Manual.

12.8 REFERENCES - STANDARD DRAWINGS

Comply with the OCSD Standard Drawings referenced below:

<u>Number</u>	<u>Description</u>
S-010	Pipe Installation and Pavement Replacement
S-011	Pipe Zone Detail for VCP Sewers in Overwidth Trench
S-012	Pipe Zone Detail for RCP Sewers in Overwidth Trench
S-015	Installation – Water Valve, Survey Monument or Sewer Cleanout Frame
S-020	Pipe Support Beam Across Trenches
S-021	Pipe Support Wall Across Trenches
S-022	Sewer House Lateral at Utility Intersections
S-023	Anchor Block Detail
S-030	VCP Installation in Casing Pipe
S-031	Flush Bell RCP Installation in Casing Pipe
S-038	Field Closure for RCP, Cases 1 and 2
S-040	Field Closure for VCP
S-042	Joints on RCP
S-043	Bell Ring Insert
S-044	Bell Ring Insert with PVC Plate Liner
S-045	Un-Lined Manhole for Sewers
S-049	New PVC-Lined Manhole Over Existing Sewer, Sheets 1, 2, 3
S-050	New PVC-Lined Manhole for New Sewers, Sheets 1, 2, 3
S-051	Drop Manhole Connection to Standard Manhole
S-052	48-in Manhole Frame and Cover with Concentric 24-in Cover
S-053	Standard Manhole Frame and Cover
S-054	Bolted Manhole Frame and Cover
S-055	Manhole Adjustment to Grade
S-056	Gas Flap Installation for PVC-Lined or Unlined Manholes, Sheets 1, 2, 3
S-057	Core Drilled Stub at Existing Manhole, Detail, Sheets 1 and 2
S-060	Diversion Structure with Stop Gate, Sheets 1, 2
S-065	Liner – PVC
S-070	Saddle Connection, Revenue Area Seven Only
S-071	Cut-in-Wye Connection, Unincorporated Area Only
S-072	House Lateral Connection, Typical
S-073	Clean Out In Roadway Detail
S-100	Concrete Encasement of Pipe

Check with the Standards Custodian in the OCSD Engineering Dept. regarding any Standards Drawing updates and/or additional Standards Drawings that may have been developed since the publication of this Guidelines Chapter and may be required for the project.

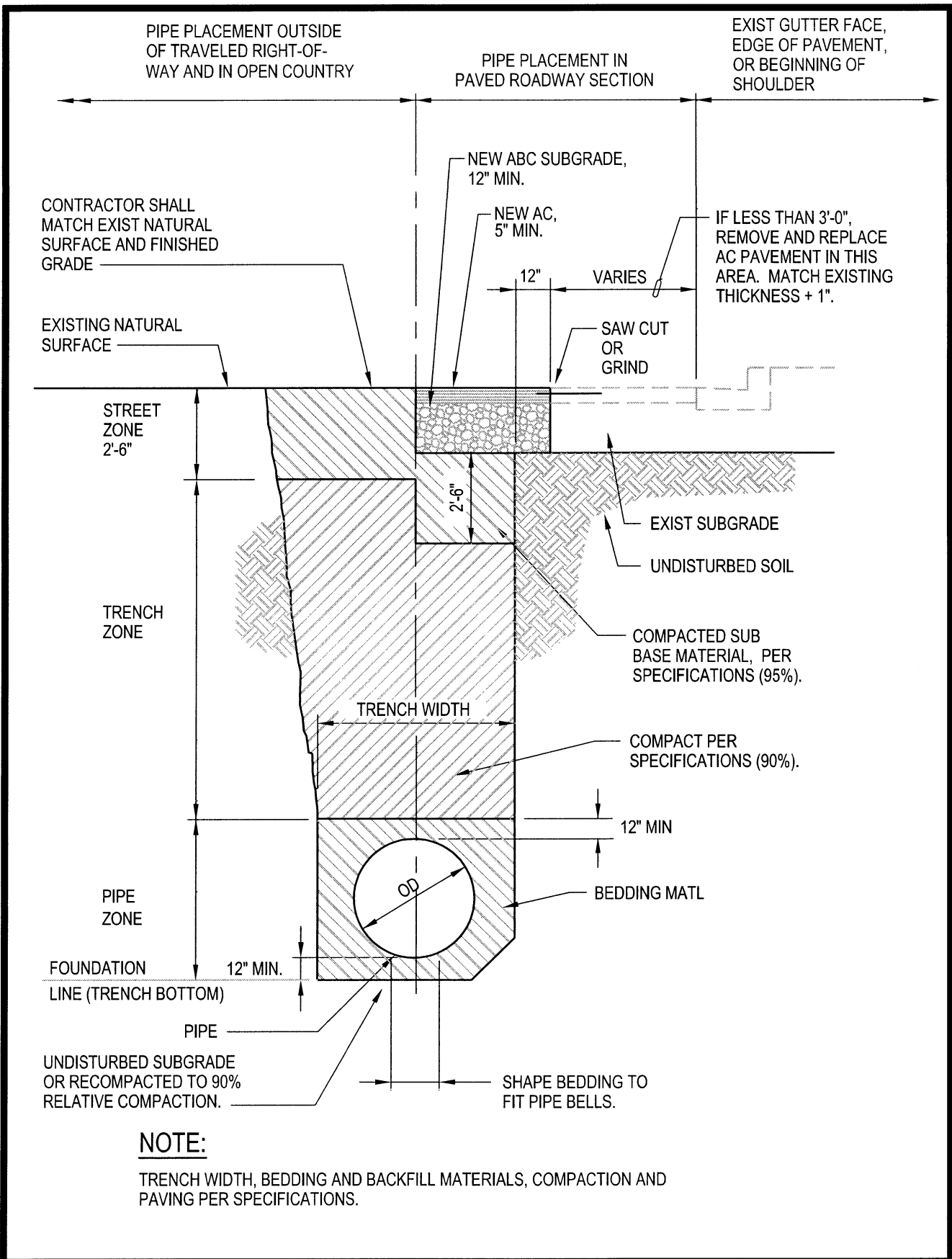

NOTE:

TRENCH WIDTH, BEDDING AND BACKFILL MATERIALS, COMPACTION AND PAVING PER SPECIFICATIONS.

			ORANGE COUNTY SANITATION DISTRICT ORANGE COUNTY, CALIFORNIA	PIPE INSTALLATION AND PAVEMENT REPLACEMENT	NO SCALE
			APPROVED BY: <i>[Signature]</i> 06/20/07		STANDARD DWG.
NO.	APPROVED	DATE	DIRECTOR OF ENGINEERING	DATE	S-010

010

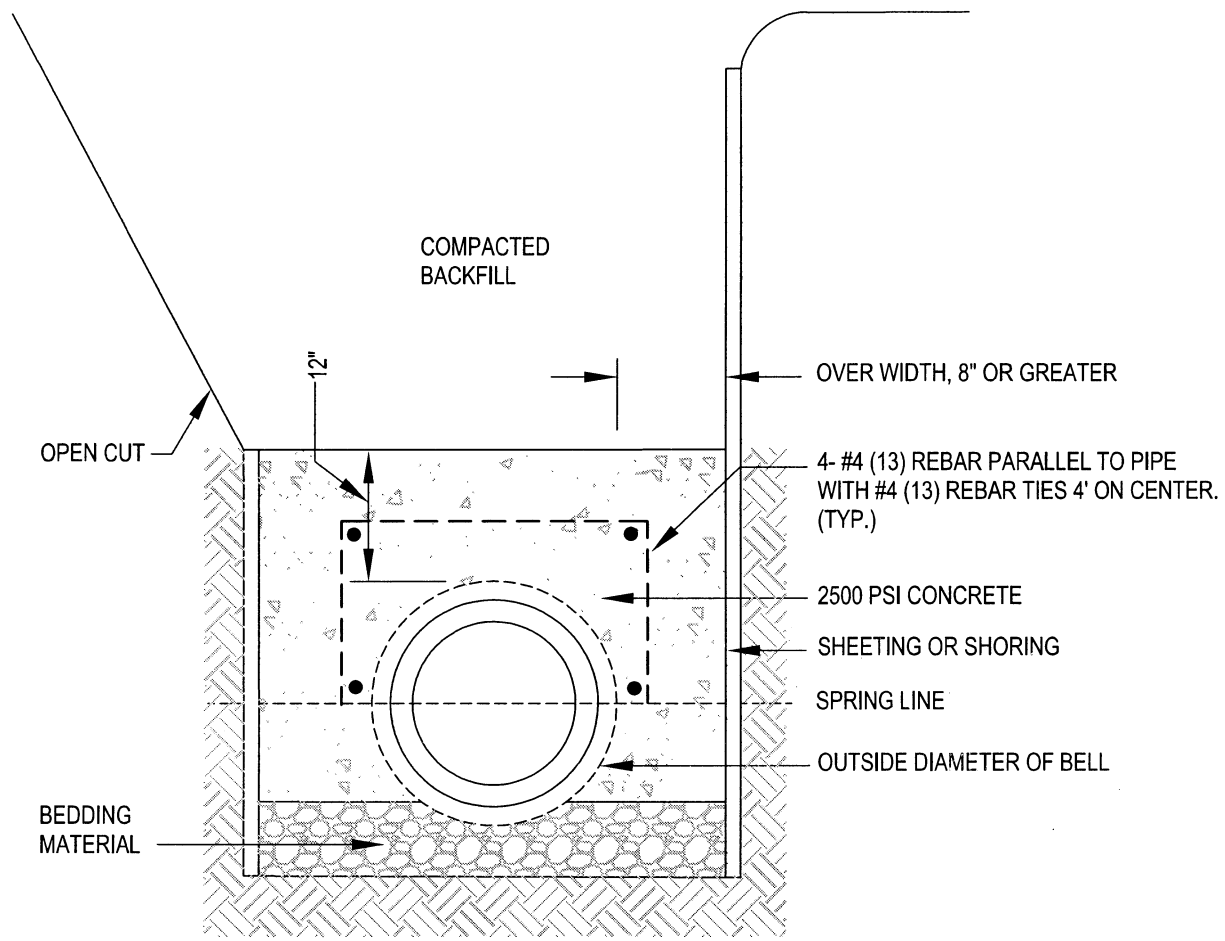

NOTES:

1. () DENOTES METRIC SYSTEM
2. THIS DETAIL APPLIES WHEN NOT OTHERWISE SPECIFIED OR SHOWN ON THE PLANS.
3. SOIL VOIDS CREATED BY SHORING SHALL BE BACKFILLED AND COMPACTED PER SPECIFICATION SECTION 02200.

011

			ORANGE COUNTY SANITATION DISTRICT ORANGE COUNTY, CALIFORNIA	PIPE ZONE DETAIL FOR VCP SEWERS IN OVERWIDTH TRENCH	NO SCALE
			APPROVED BY <i>[Signature]</i> 05/20/07		STANDARD DWG.
NO.	APPROVED	DATE	DIRECTOR OF ENGINEERING		S-011

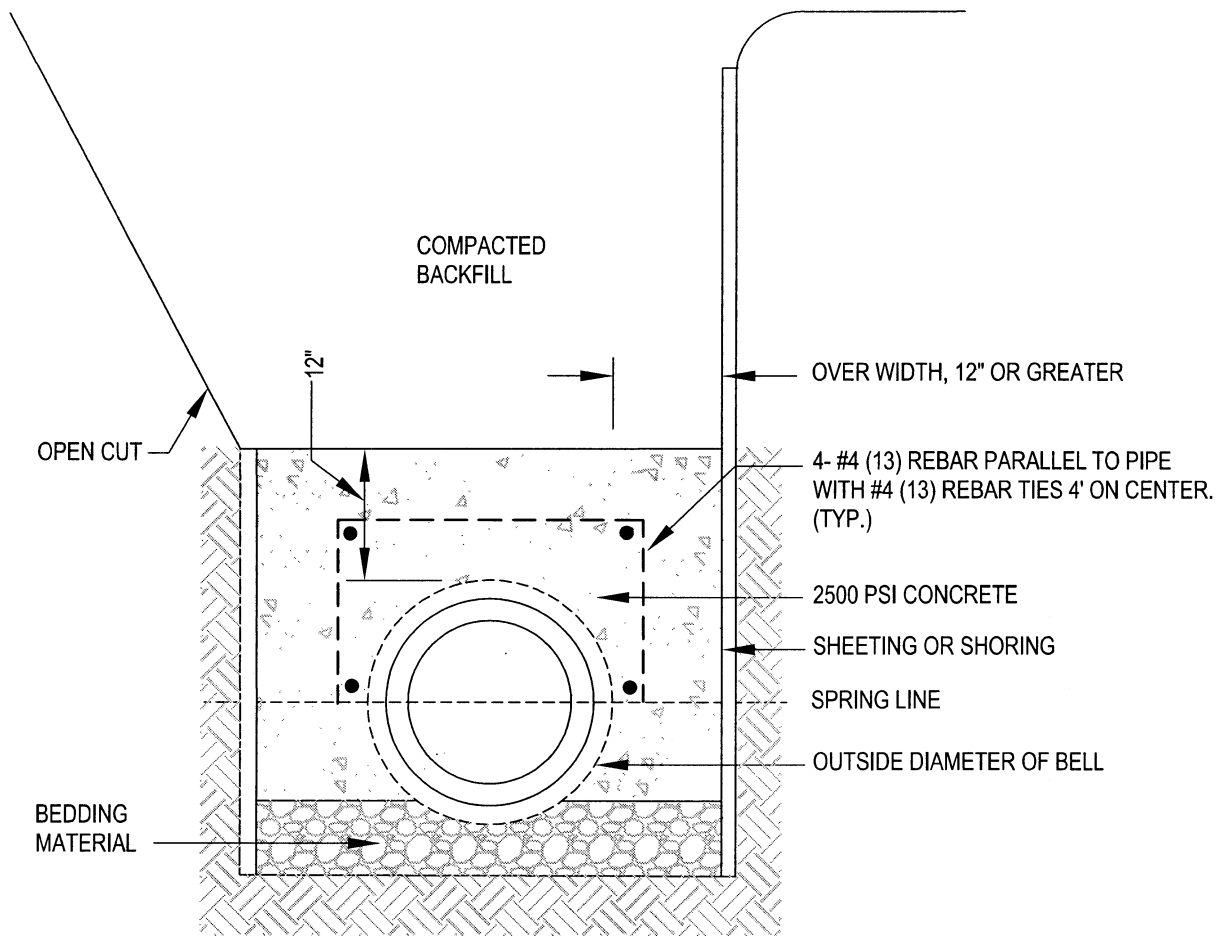

NOTES:

- 1. () DENOTES METRIC SYSTEM
- 2. THIS DETAIL APPLIES WHEN NOT OTHERWISE SPECIFIED OR SHOWN ON THE PLANS.
- 3. SOIL VOIDS CREATED BY SHORING SHALL BE BACKFILLED AND COMPACTED PER SPECIFICATION SECTION 02200.

			ORANGE COUNTY SANITATION DISTRICT ORANGE COUNTY, CALIFORNIA		PIPE ZONE DETAIL FOR RCP SEWERS IN OVERWIDTH TRENCH		NO SCALE	
			APPROVED BY <i>A. Heber</i> 06/20/07				STANDARD DWG.	
NO.	APPROVED	DATE	DIRECTOR OF ENGINEERING		DATE		S-012	

012

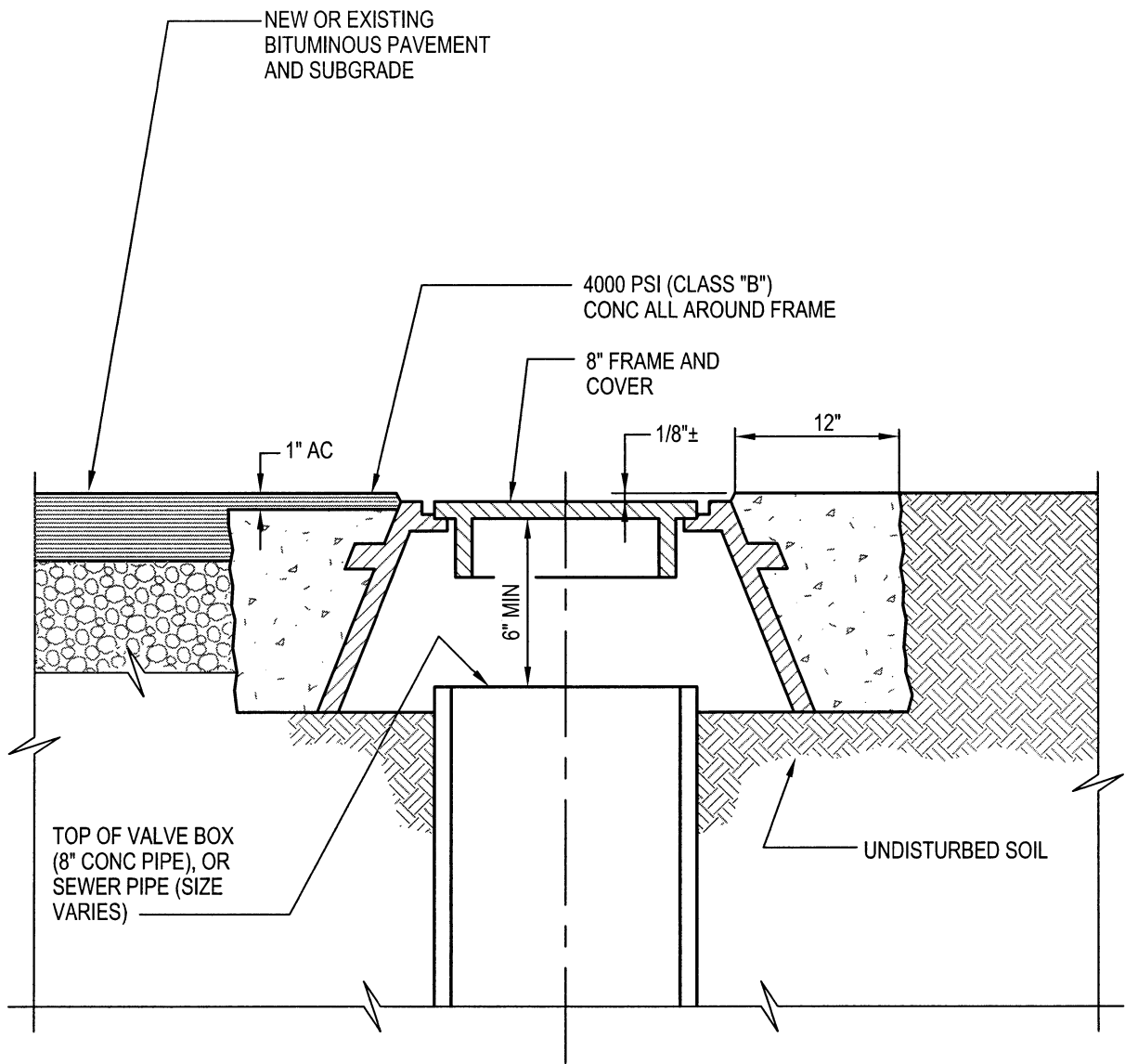

015

NO.	APPROVED	DATE

ORANGE COUNTY SANITATION DISTRICT
ORANGE COUNTY, CALIFORNIA

APPROVED BY *[Signature]* 06/20/07

DIRECTOR OF ENGINEERING DATE

VALVE BOX, SURVEY MONUMENT,
OR SEWER CLEAN OUT COVER
AND FRAME INSTALLATION

NO SCALE
STANDARD DWG.
S-015

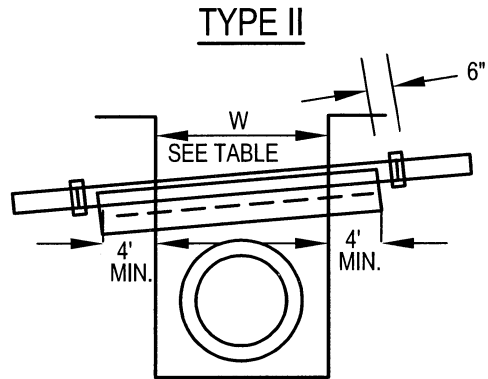
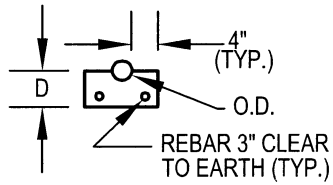
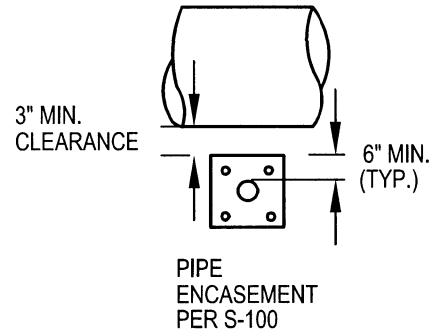
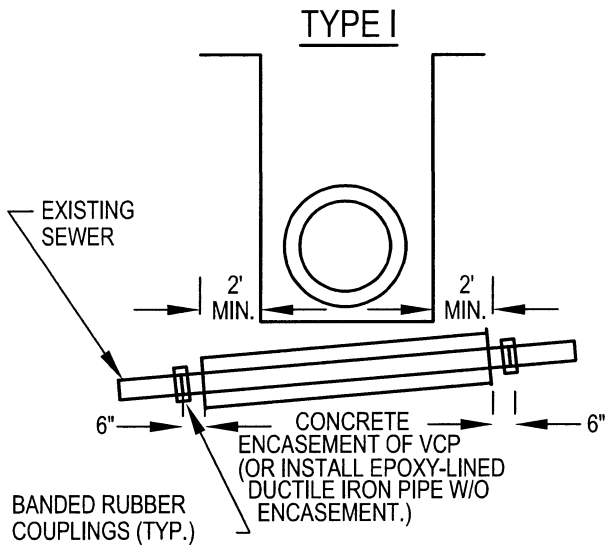

W	DEPTH OF COVER			
	0' TO 8'		8' TO 16'	
	D	BAR #	D	BAR #
3'	12"	4(13)	12"	4(13)
4'	12"	4(13)	12"	5(16)
5'	12"	4(13)	16"	5(16)
6'	12"	5(16)	16"	5(16)
7'	12"	5(16)	16"	6(19)
8'	12"	5(16)	16"	6(19)
9'	12"	6(19)	16"	8(25)
10'	12"	6(19)	16"	8(25)

BEAM THICKNESS FOR TYPE II
BAR SIZE FOR TYPE I AND TYPE II

NOTE:

() DENOTES METRIC SYSTEM.

020

			ORANGE COUNTY SANITATION DISTRICT ORANGE COUNTY, CALIFORNIA		PIPE SUPPORT BEAM ACROSS TRENCHES		NO SCALE	
			APPROVED BY <i>H. Verbay</i> 06/20/07				STANDARD DWG.	
NO.	APPROVED	DATE	DIRECTOR OF ENGINEERING				S-020	

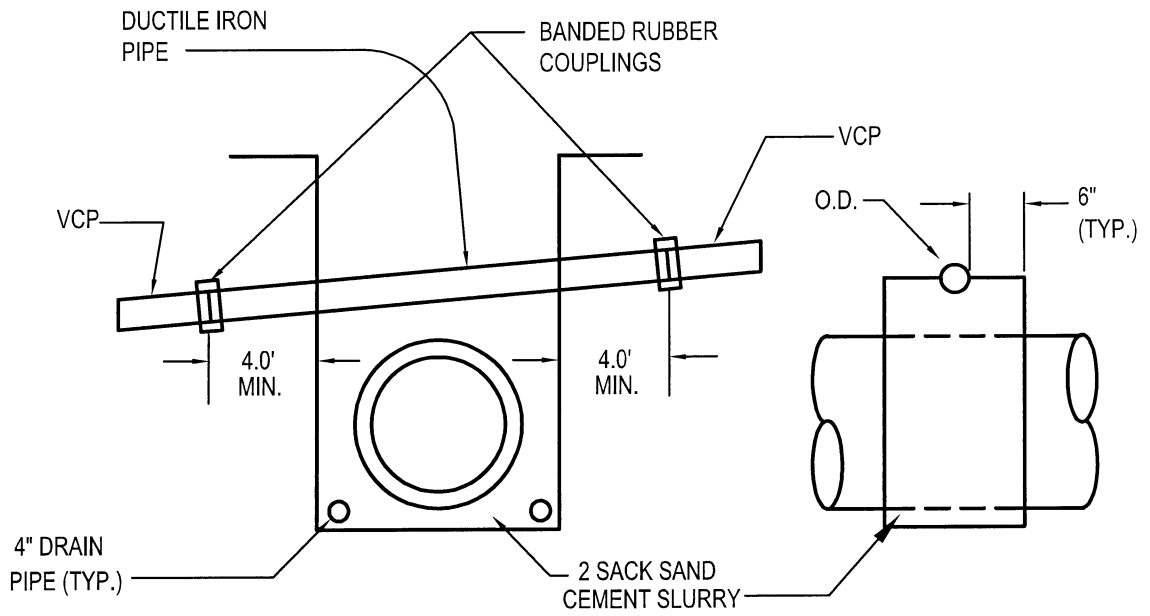

NOTE:

THIS DETAIL MAY BE USED ONLY WITH PRIOR APPROVAL OF THE DISTRICT ENGINEER.

021

			ORANGE COUNTY SANITATION DISTRICT ORANGE COUNTY, CALIFORNIA	PIPE SUPPORT WALL ACROSS TRENCHES	NO SCALE
			APPROVED BY <i>Herb</i> 6-21-07		STANDARD DWG.
NO.	APPROVED	DATE	DIRECTOR OF ENGINEERING	DATE	S-021

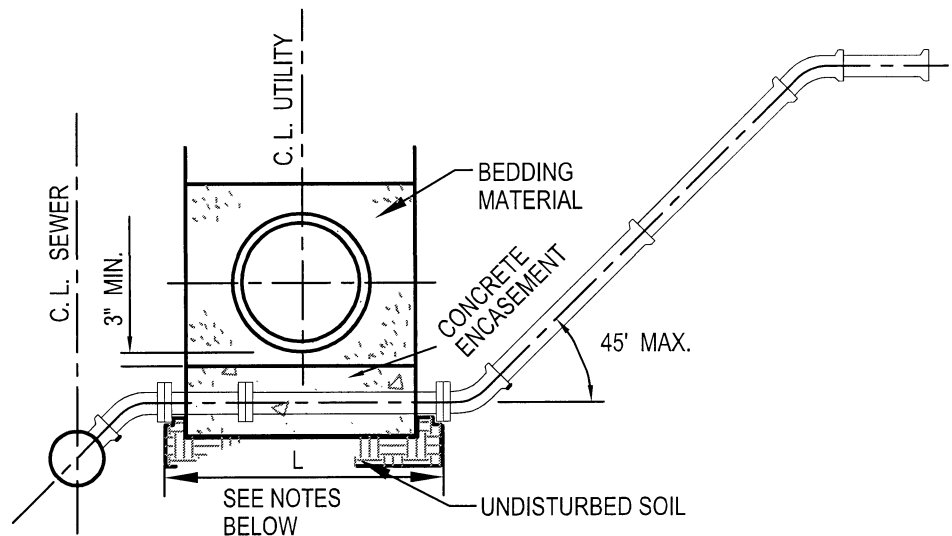

TYPE I

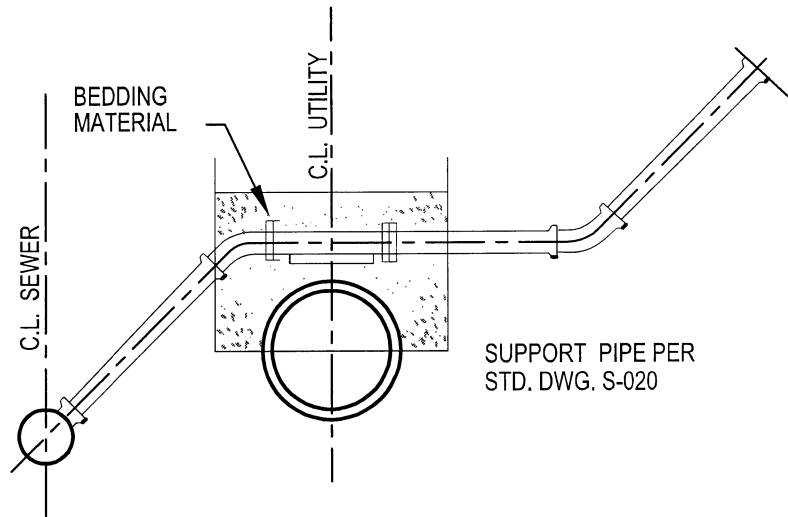

TYPE II

NOTES:

1. ANY OTHER PROPOSED DESIGN SHALL HAVE THE DISTRICT ENGINEER'S APPROVAL PRIOR TO THE START OF CONSTRUCTION.
2. MINIMUM SLOPE FOR SEWER LATERAL SHALL BE 1/4" PER FOOT.
3. L= WIDTH OF STORM DRAIN TRENCH PLUS EXTENSION AT BOTH SIDES TO FIRST PIPE JOINT AT OR BEYOND TRENCH.
4. LATERALS SHALL HAVE A MINIMUM OF 5' OF COVER AT THE PROPERTY LINE.
5. ALL ENCASED SEWER PIPE SHALL BE DUCTILE IRON WITH BANDED RUBBER COUPLINGS.
6. ALL ENCASEMENTS SHALL BE CLASS 'A' CONCRETE.

022

			ORANGE COUNTY SANITATION DISTRICT ORANGE COUNTY, CALIFORNIA	SEWER HOUSE LATERAL AT UTILITY INTERSECTIONS	NO SCALE
			APPROVED BY <i>Montez</i> 6-21-07 DIRECTOR OF ENGINEERING		STANDARD DWG. S-022
NO.	APPROVED	DATE			

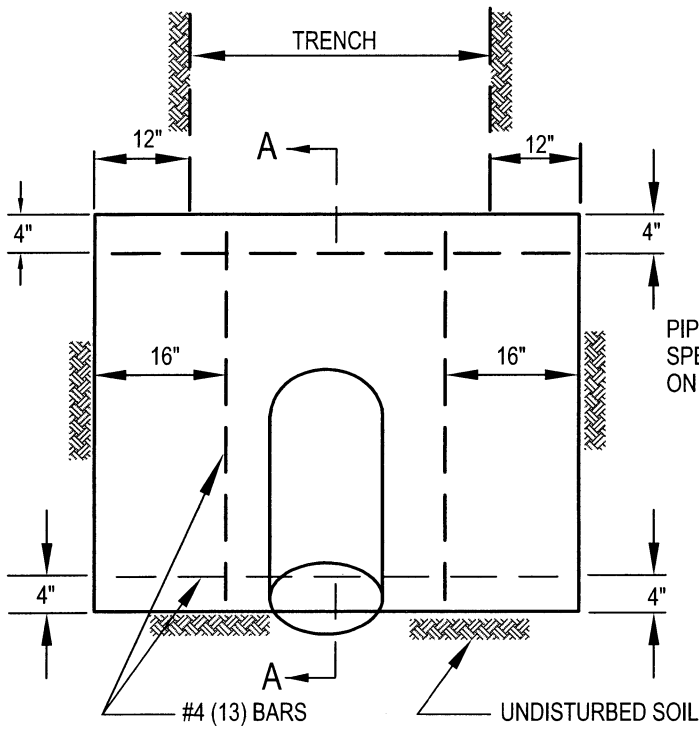

ELEVATION

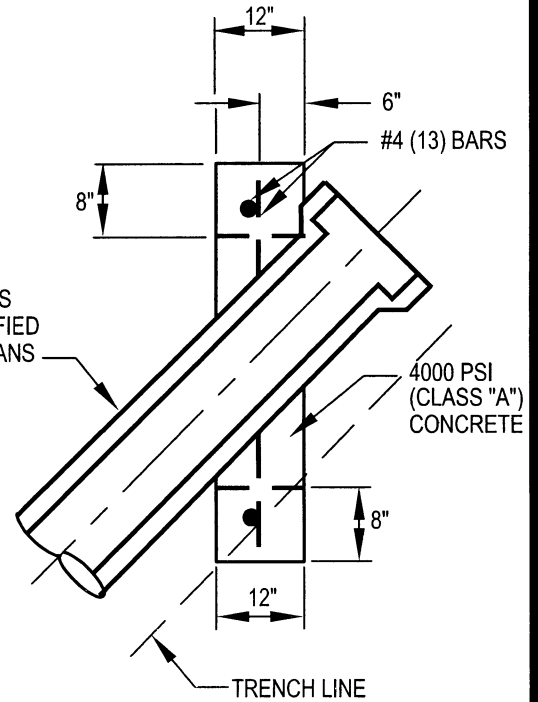

SECTION A-A

NOTES:

1. PIPE ANCHOR BLOCKS SHALL BE INSTALLED ON ALL SEWERS WHERE THE SLOPE EXCEEDS 30%.
2. SPACING SHALL BE 100' ON CENTER WHERE SLOPES ARE 30% TO 50%, 75' ON CENTER WHERE SLOPES ARE 51% TO 70% AND 50' ON CENTER WHERE SLOPES ARE 71% AND GREATER.

() DENOTES METRIC SYSTEM.

023

			ORANGE COUNTY SANITATION DISTRICT ORANGE COUNTY, CALIFORNIA	ANCHOR BLOCK DETAIL	NO SCALE
			APPROVED BY <i>[Signature]</i> DIRECTOR OF ENGINEERING		STANDARD DWG. S-023
NO.	APPROVED	DATE			

GROUT CONNECTION HOLES SPACED 8' ON CENTER IN EACH ROW & STAGGERED 4' SO AS TO OCCUR ON ALTERNATE SIDES OF CROWN.

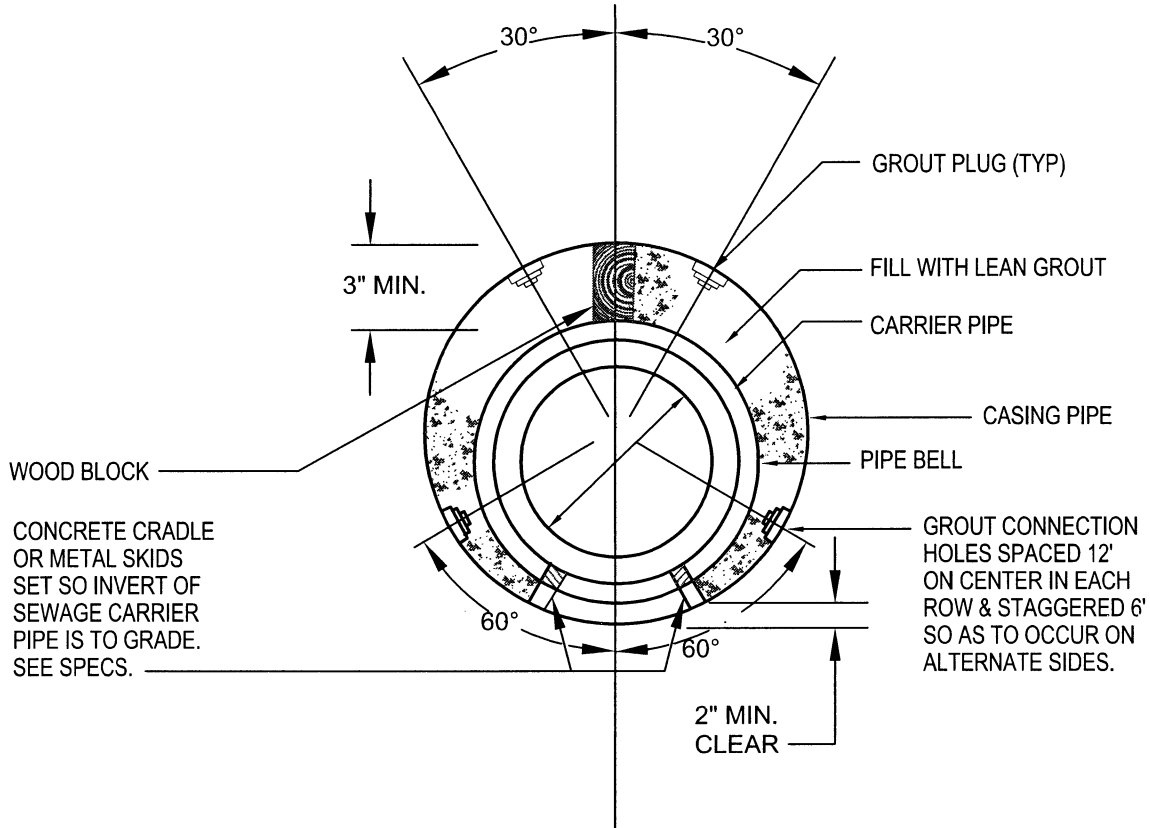

NOTES:

1. ALL STEEL CASING PIPE FIELD JOINTS SHALL BE WELDED FULL CIRCUMFERENCE.
2. PERIPHERY OF CASING TO BE PRESSURE GROUTED.
3. CARRIER PIPE SHALL BE AIR TESTED PRIOR TO FILLING CASING WITH GROUT.
4. THE ELEVATIONS AND SLOPE OF THE CARRIER PIPE SHALL BE SURVEYED AND APPROVED BY THE ENGINEER PRIOR TO FILLING CASING.

030

			ORANGE COUNTY SANITATION DISTRICT ORANGE COUNTY, CALIFORNIA	VCP INSTALLATION	NO SCALE
			APPROVED BY <i>A. H. H.</i> 06/23/07	IN	STANDARD DWG.
			DIRECTOR OF ENGINEERING	CASING PIPE	S-030
NO.	APPROVED	DATE			

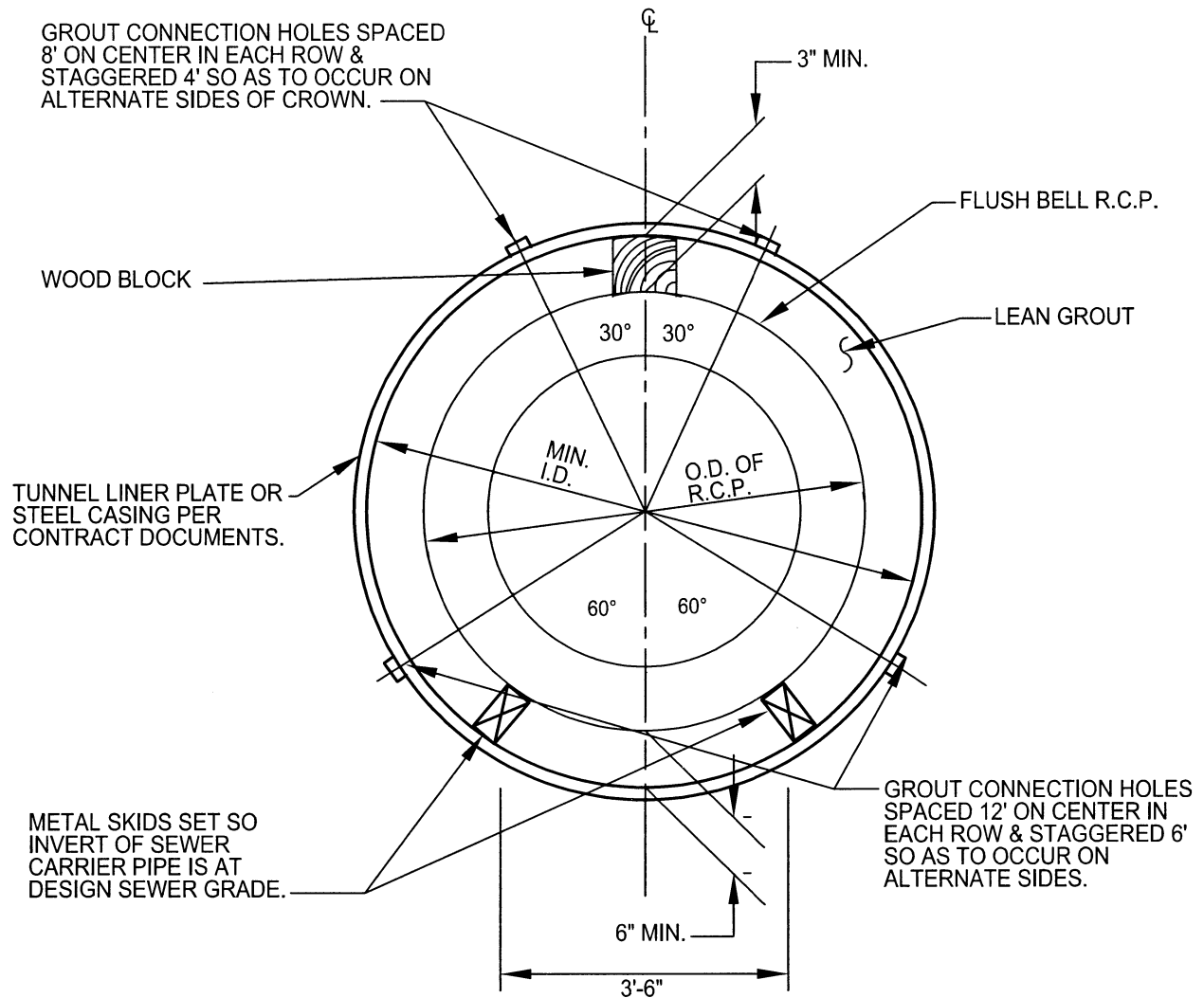

NOTES:

1. ALL STEEL CASING PIPE FIELD JOINTS SHALL BE WELDED FULL CIRCUMFERENCE.
2. PERIPHERY OF CASING TO BE PRESSURE GROUTED.
3. CARRIER PIPE SHALL BE AIR TESTED PRIOR TO FILLING CASING WITH GROUT.
4. THE ELEVATIONS AND SLOPE OF THE CARRIER PIPE SHALL BE SURVEYED AND APPROVED BY THE ENGINEER PRIOR TO FILLING CASING.
5. THE ELEVATIONS AND SLOPE OF THE CARRIER PIPE SHALL BE SURVEYED AND APPROVED BY THE ENGINEER PRIOR TO FILLING CASING.

031

			ORANGE COUNTY SANITATION DISTRICT ORANGE COUNTY, CALIFORNIA	FLUSH BELL PIPE INSTALLATION IN CASING PIPE	NO SCALE
			APPROVED BY <i>Heb</i> 06/20/07 DIRECTOR OF ENGINEERING		STANDARD DWG. S-031
NO.	APPROVED	DATE			

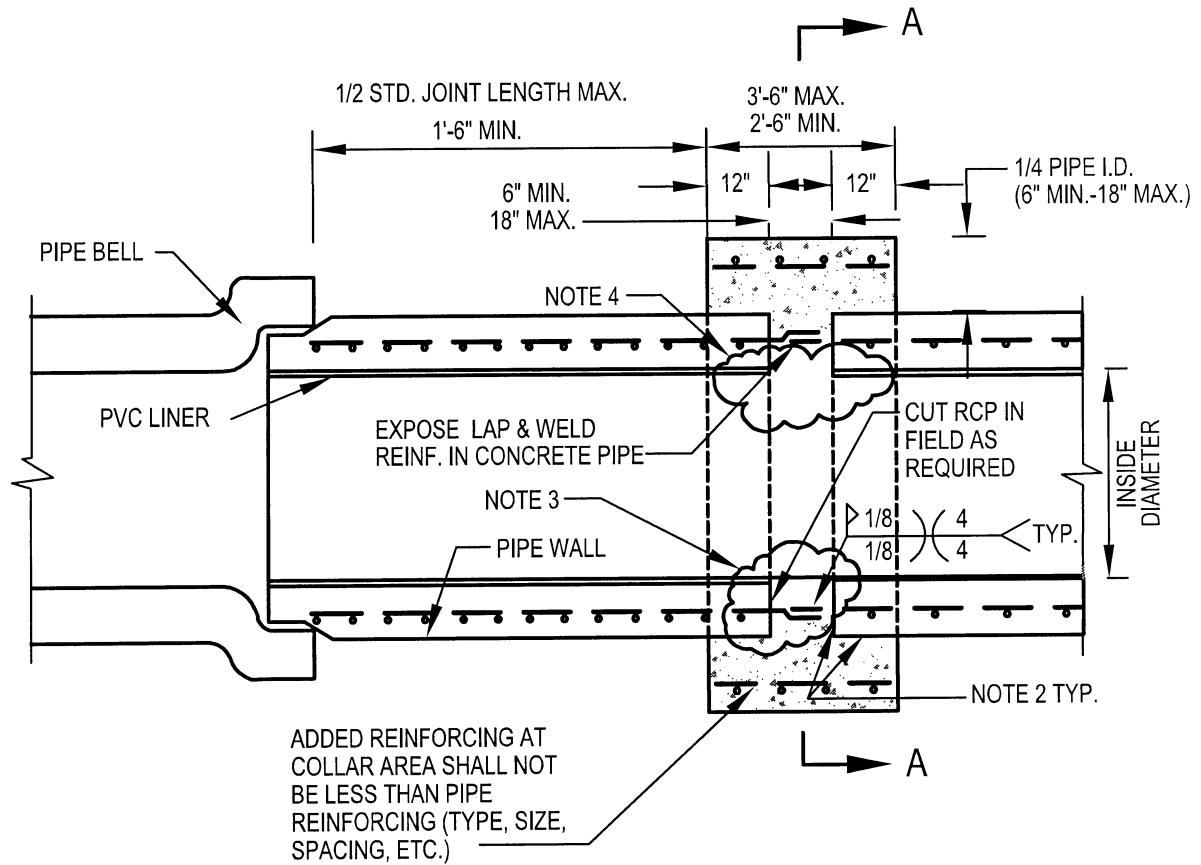

ADDED REINFORCING AT COLLAR AREA SHALL NOT BE LESS THAN PIPE REINFORCING (TYPE, SIZE, SPACING, ETC.)

NOTES:

1. FIELD CLOSURE SHALL BE USED ONLY WHEN NECESSARY AND WHEN APPROVED BY THE ENGINEER. PIPE BEDDING SHALL BE USED AT FIELD CLOSURE. THE SAME TYPE AND DEPTH OF BEDDING USED UNDER THE PIPE SHALL BE USED UNDER THE FIELD CLOSURE. LOCATION OF FIELD CLOSURE SHALL BE SUBJECT TO THE ENGINEERS APPROVAL.
2. SANDBLAST AROUND PIPE AND PIPE ENDS, APPLY BONDING AGENT PER MANUFACTURERS INSTRUCTIONS PRIOR TO CONCRETE ENCASEMENT.
3. CUT REBAR IN FIELD AS REQUIRED. CIRCULAR AND LONGITUDINAL STEEL IN CLOSURE AREA SHALL BE SAVED OR REPLACED PER MANUFACTURER DATA SHEET.
4. PVC LINER SPLICE SHALL HAVE TEES EMBEDDED, HEAT FUSED TO EXISTING LINERS WITH ADDITIONAL 1" OFFSET JOINT STRIPS WELDED EACH SIDE.
5. USE STANDARD HOOKS AT CORNERS (TYP.)
6. PLACE CONCRETE FULL LENGTH BOTTOM OF PIPE FOR CLOSURE AND SYNTHETIC SPONGE RUBBER EXPANSION JOINT MATERIAL BETWEEN PAD AND EXISTING PIPE ENDS. (CASE 2 ONLY)

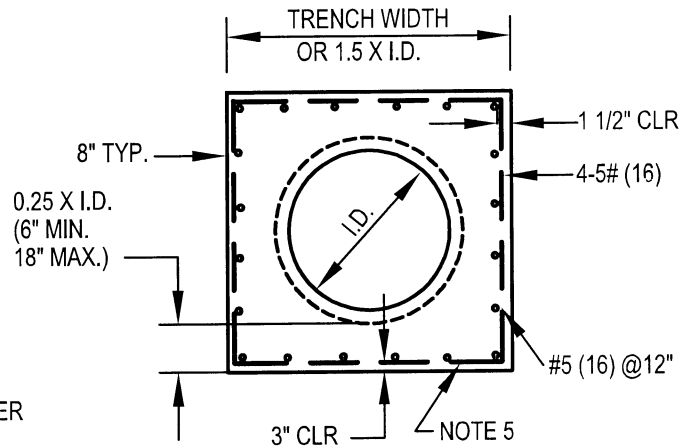

SECTION A-A

() DENOTES METRIC SYSTEM

NO.	APPROVED	DATE

ORANGE COUNTY SANITATION DISTRICT
ORANGE COUNTY, CALIFORNIA

APPROVED BY: *[Signature]* 6-21-07
DIRECTOR OF ENGINEERING DATE

FIELD CLOSURE
FOR R.C.P.
CASES 1 & 2

NO SCALE
STANDARD DWG.
S-038

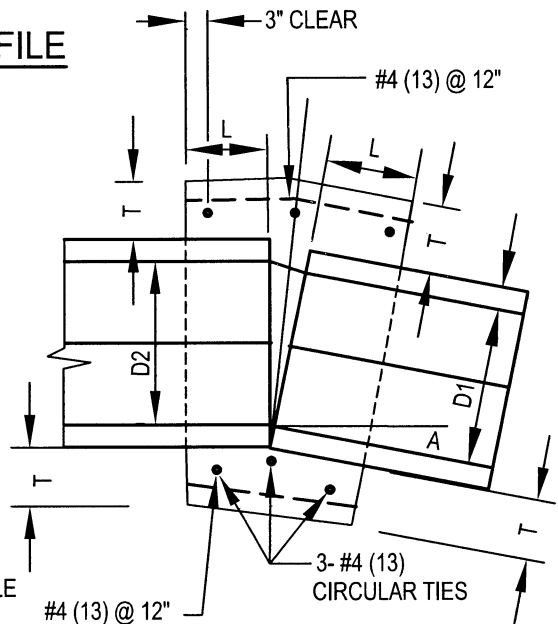
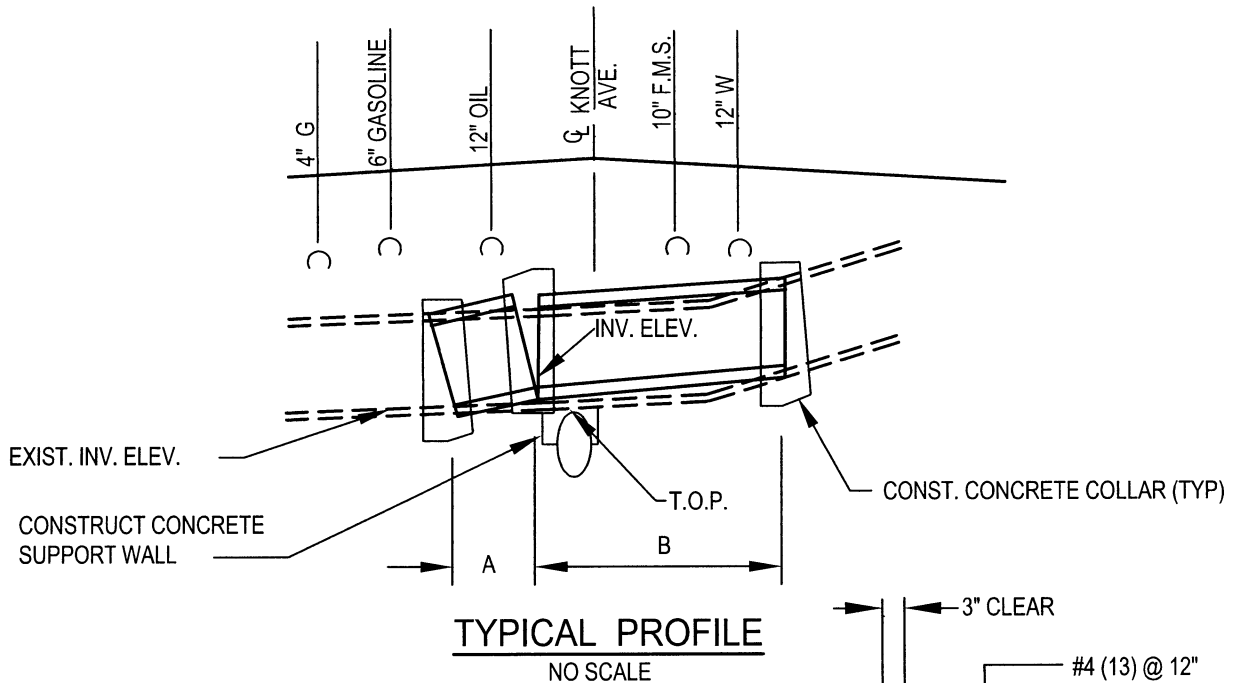

NOTES:

1. A CONCRETE COLLAR IS REQUIRED WHERE THE CHANGE IN GRADE EXCEEDS 0.10 FEET PER FOOT.
2. WHERE PIPES OF DIFFERENT DIAMETERS ARE JOINED WITH A CONCRETE COLLAR. L AND T SHALL BE THOSE OF THE LARGER PIPE D=D1 OR D2, WHICHEVER IS GREATER.
3. FOR PIPE SIZE NOT LISTED USE NEXT SIZE LARGER.
4. OMIT REINFORCING ON PIPES 24" AND LESS IN DIAMETER AND ON ALL PIPES WHERE ANGLE CHANGE IS LESS THAN 0.10 FEET PER FOOT.
5. WHERE REINFORCING IS REQUIRED THE DIAMETER OF THE CIRCLE TIES SHALL BE $D + (2 \times \text{WALL THICKNESS}) + 8$.
6. WHEN D1 IS EQUAL TO OR LESS THAN D2, JOIN INVERTS AND WHEN D1 IS GREATER THAN D2, JOIN SOFFITS.
7. NOT TO BE USED FOR A SIZE CHANGE ON THE MAINLINE.
8. USE 4000 PSI (CLASS "A") CONCRETE.
9. DIMENSIONS A,B, ELEVATIONS AND SLOPES (S=0....) SHALL BE SHOWN ON THE PLANS.
10. THE INSIDE OF THE FIELD CLOSURE SHALL BE BARREL FORMED UTILIZING T-LOCK PVC AND ANGLE TURNBACKS AT EDGES, CAULK EDGES OF PVC.

() DENOTES METRIC SYSTEM

TYPICAL CONCRETE COLLAR

NO SCALE

D	L	T
12"	12"	4"
18"	12"	5"
24"	12"	6"
36"	18"	8"
42"	18"	9"

NO.	APPROVED	DATE

ORANGE COUNTY SANITATION DISTRICT
ORANGE COUNTY, CALIFORNIA
APPROVED BY *A. Lopez* 06/20/07
DIRECTOR OF ENGINEERING DATE

FIELD CLOSURE
FOR VCP

NO SCALE
STANDARD DWG.
S-040

040

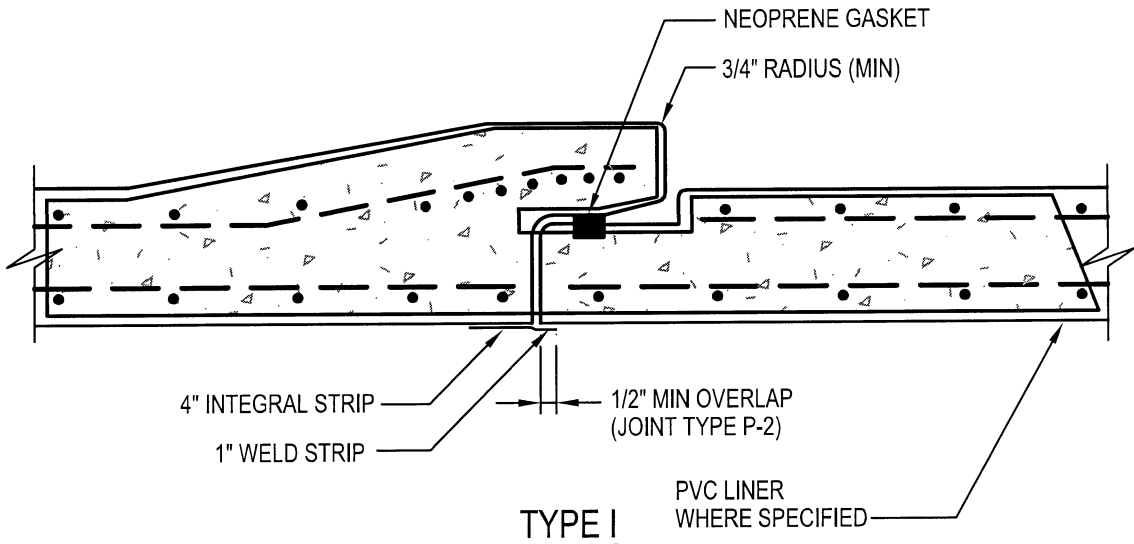

TYPE I

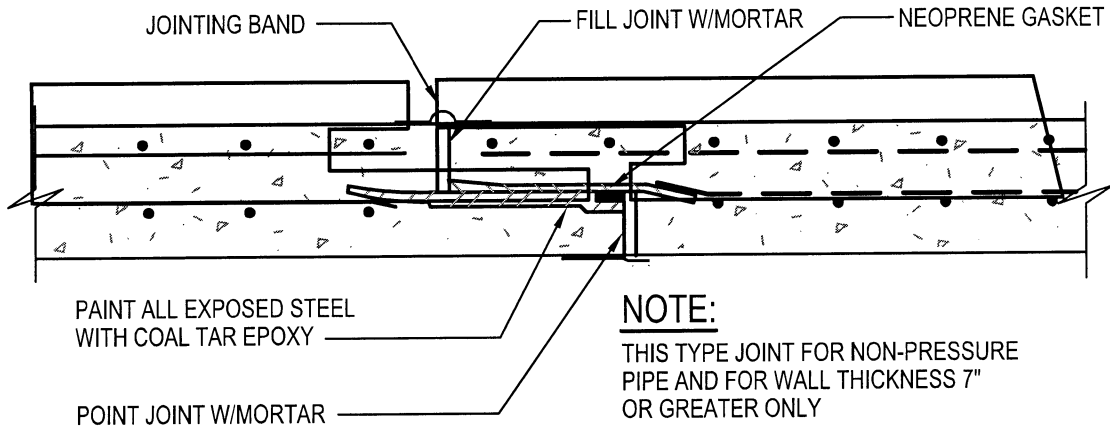

NOTE:
 THIS TYPE JOINT FOR NON-PRESSURE PIPE AND FOR WALL THICKNESS 7" OR GREATER ONLY

TYPE II

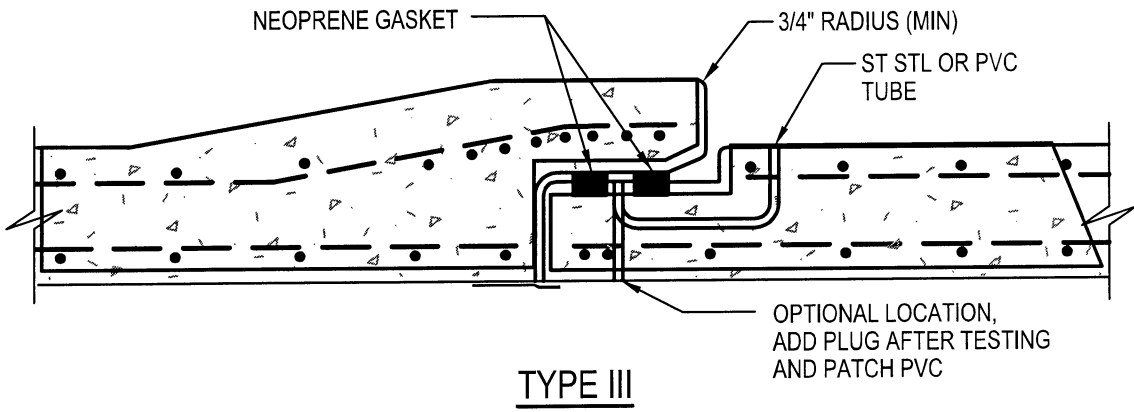

TYPE III

LINER JOINT TYPE P-2 SHOWN. FOR ALTERNATE TYPE P-1, PROVIDE 4" JOINT STRIP WITH WELD STRIP EACH SIDE. SEE SPECIFICATIONS FOR DESCRIPTION OF JOINT TYPES.

042

			ORANGE COUNTY SANITATION DISTRICT ORANGE COUNTY, CALIFORNIA	JOINTS ON R.C.P.	NO SCALE
			APPROVED BY <i>A. Healy</i> 6-21-07 DIRECTOR OF ENGINEERING		STANDARD DWG.
NO.	APPROVED	DATE			S-042

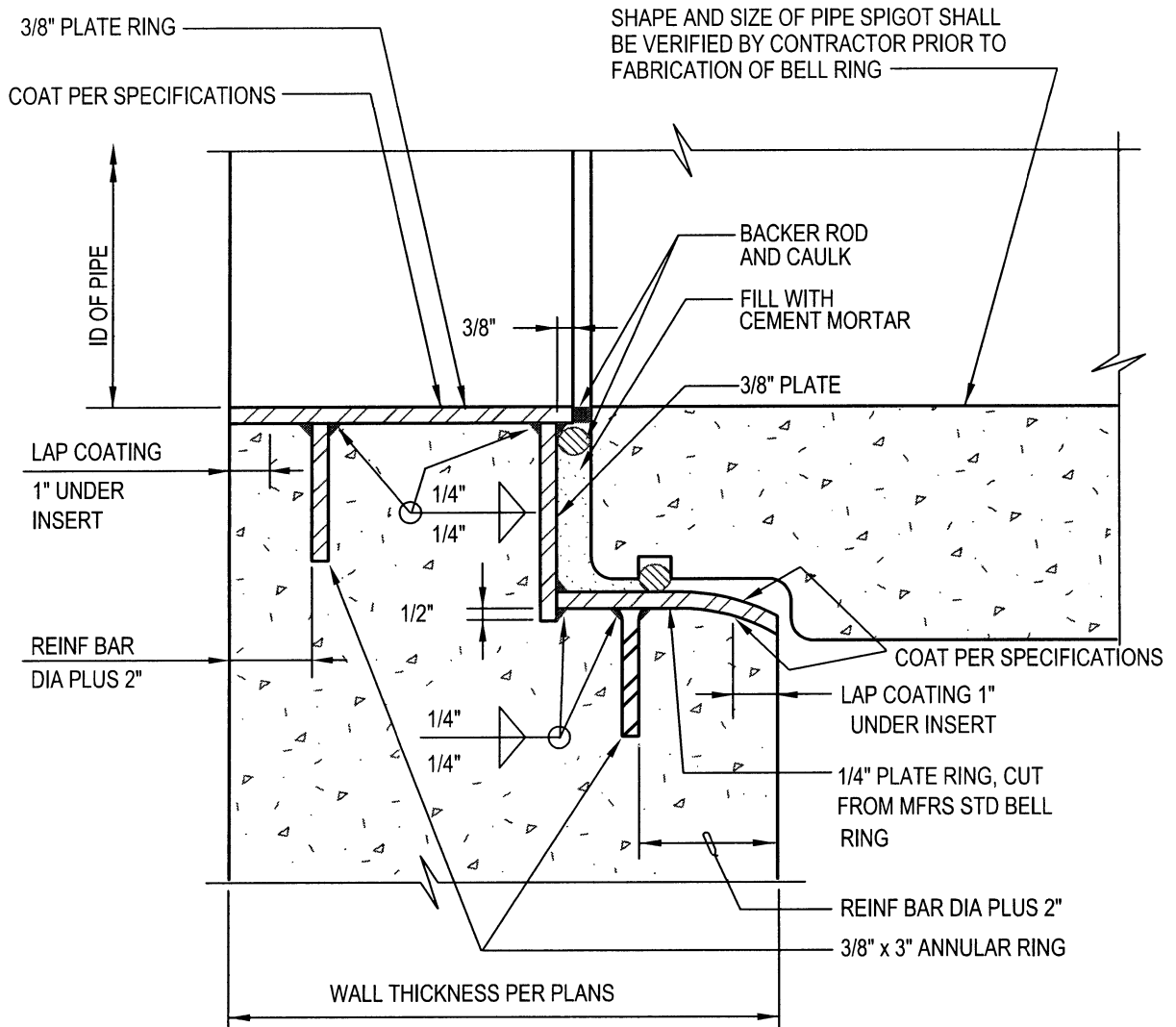

NOTES:

1. WELD ALL CUT REINFORCING BARS TO ANNULAR RING FOR PIPES GREATER THAN 48" DIAMETER. USE LOW HYDROGEN WELDING ER 70XX.
2. GRIND SMOOTH ALL METAL EDGES IN AREAS TO BE COATED AND ALL SURFACES IN PIPE SEATING AREA.
3. RING SHALL HAVE SPIDER BRACING INSTALLED AT POINT OF MANUFACTURE TO MAINTAIN ROUNDNESS.
4. ALL WELDS SHALL BE DYE TESTED PRIOR TO SHIPMENT.

NO.	APPROVED	DATE

ORANGE COUNTY SANITATION DISTRICT
 ORANGE COUNTY, CALIFORNIA
 APPROVED BY *A. Weber* 06/20/07
 DIRECTOR OF ENGINEERING DATE

BELL - RING
 INSERT

NO SCALE
 STANDARD DWG.
 S-043

043

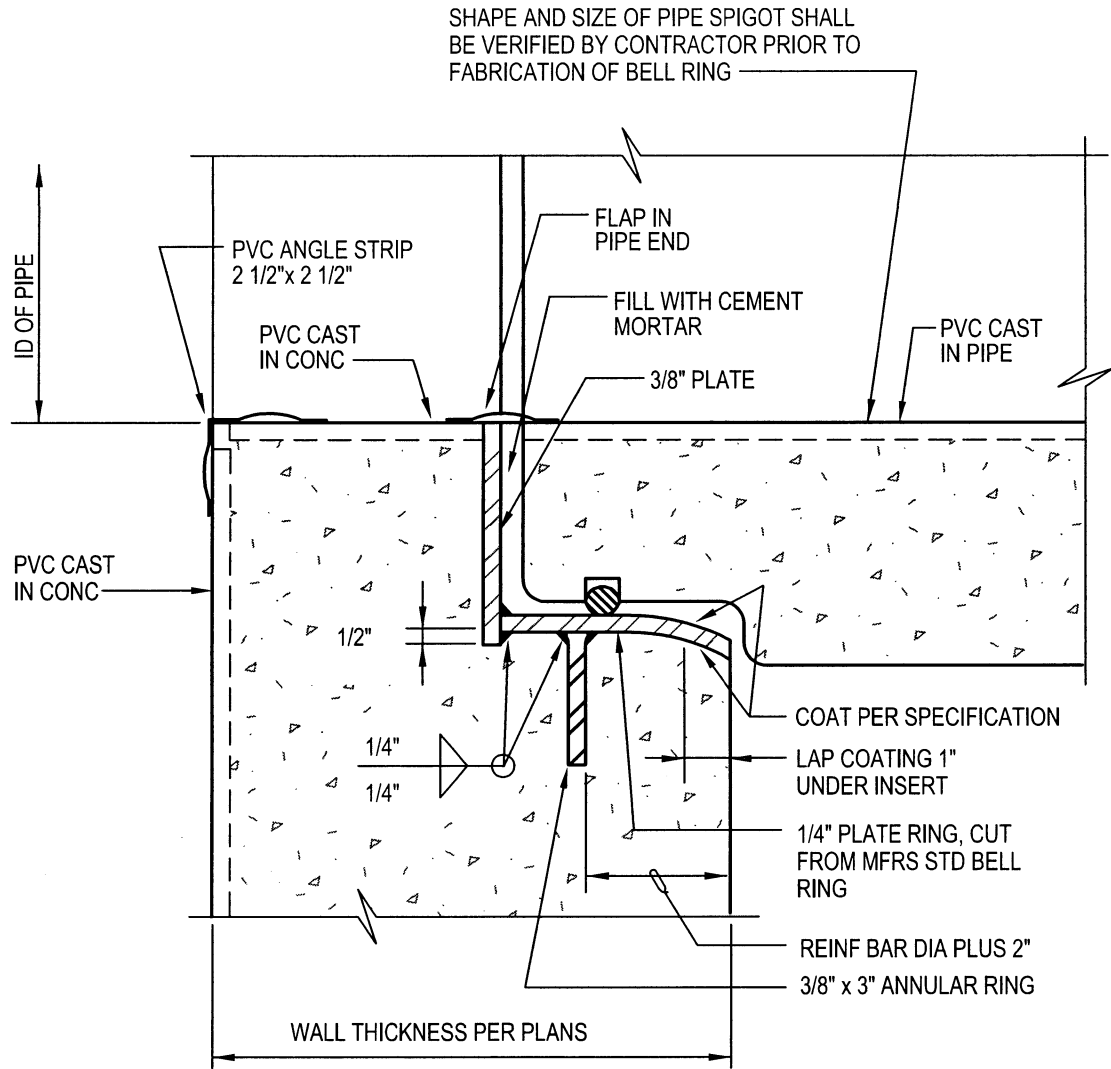

NOTES:

1. WELD ALL CUT REINFORCING BARS TO ANNULAR RING FOR PIPES GREATER THAN 48" DIAMETER. USE LOW HYDROGEN WELDING ER 70XX.
2. GRIND SMOOTH ALL METAL EDGES IN AREAS TO BE COATED AND ALL SURFACES IN PIPE SEATING AREA.
3. RING SHALL HAVE SPIDER BRACING INSTALLED AT POINT OF MANUFACTURE TO MAINTAIN ROUNDNESS.
4. ALL WELDS SHALL BE DYE TESTED PRIOR TO SHIPMENT.

			ORANGE COUNTY SANITATION DISTRICT ORANGE COUNTY, CALIFORNIA	BELL-RING INSERT	NO SCALE
			APPROVED BY <i>A. Herbay</i> 06/20/07	WITH PVC PLATE LINER	STANDARD DWG.
NO.	APPROVED	DATE	DIRECTOR OF ENGINEERING		S-044

044

FRAME AND COVER
PER DWG. S-053

3/4" TO 1"
A.C. PAVING

CLASS "B"
CONCRETE COLLAR

1/2" MORTAR
JOINT (TYP)

FACTORY
PLUG

BRICK & MORTAR PLUG

8"
MIN.

3"
MIN.

I.D.

18" MIN.
24" MAX.

26" OR 38"

12"

12"

12" MIN.
24" MAX.

C

A

B

PIPE SIZE	A	B	C	D
8"-10"	48"	6"	24"	24"
12"-21"	60"	8"	36"	24"
OVER 21" PIPE SEE OCSD STD. S-050				

NOTES:

1. NO STEPS ARE ALLOWED IN ANY MANHOLE. ALL SHAFTS AND CONES SHALL BE PRECAST. ECCENTRIC CONE SHALL BE SET WITH STRAIGHT SIDE ON THE DOWNSTREAM SIDE OF THE MANHOLE. SHAFT AND CONE MAY BE REINFORCED OR NON-REINFORCED.
2. MANHOLE BASE SHALL BE POURED WITH CLASS "A" CONCRETE.
3. SIDES OF BASE SHALL BE EITHER FORMED OR POURED AGAINST VERTICAL SMOOTH EARTH
4. CROWN OF LATERAL SHALL MATCH CROWN OF MAIN.
5. MANHOLE PLACED IN UNPAVED AREAS SHALL HAVE THEIR FRAMES AND COVERS SET 18" ABOVE FINISHED GRADE.
6. WHEN THE DEPTH OF MANHOLE EXCEEDS 15' FROM THE TOP OF PIPE TO FINISHED GRADE . THE MANHOLE SHAFT SHALL BE INCREASED TO A DIAMETER OF 60".

045

NO.	APPROVED	DATE
	REVISD	2/10/00

ORANGE COUNTY SANITATION DISTRICT
ORANGE COUNTY, CALIFORNIA

APPROVED BY
A. Hervey 6-21-07
DIRECTOR OF ENGINEERING DATE

UN - LINED
MANHOLE
FOR SEWERS

NO SCALE
STANDARD DWG.
S-045

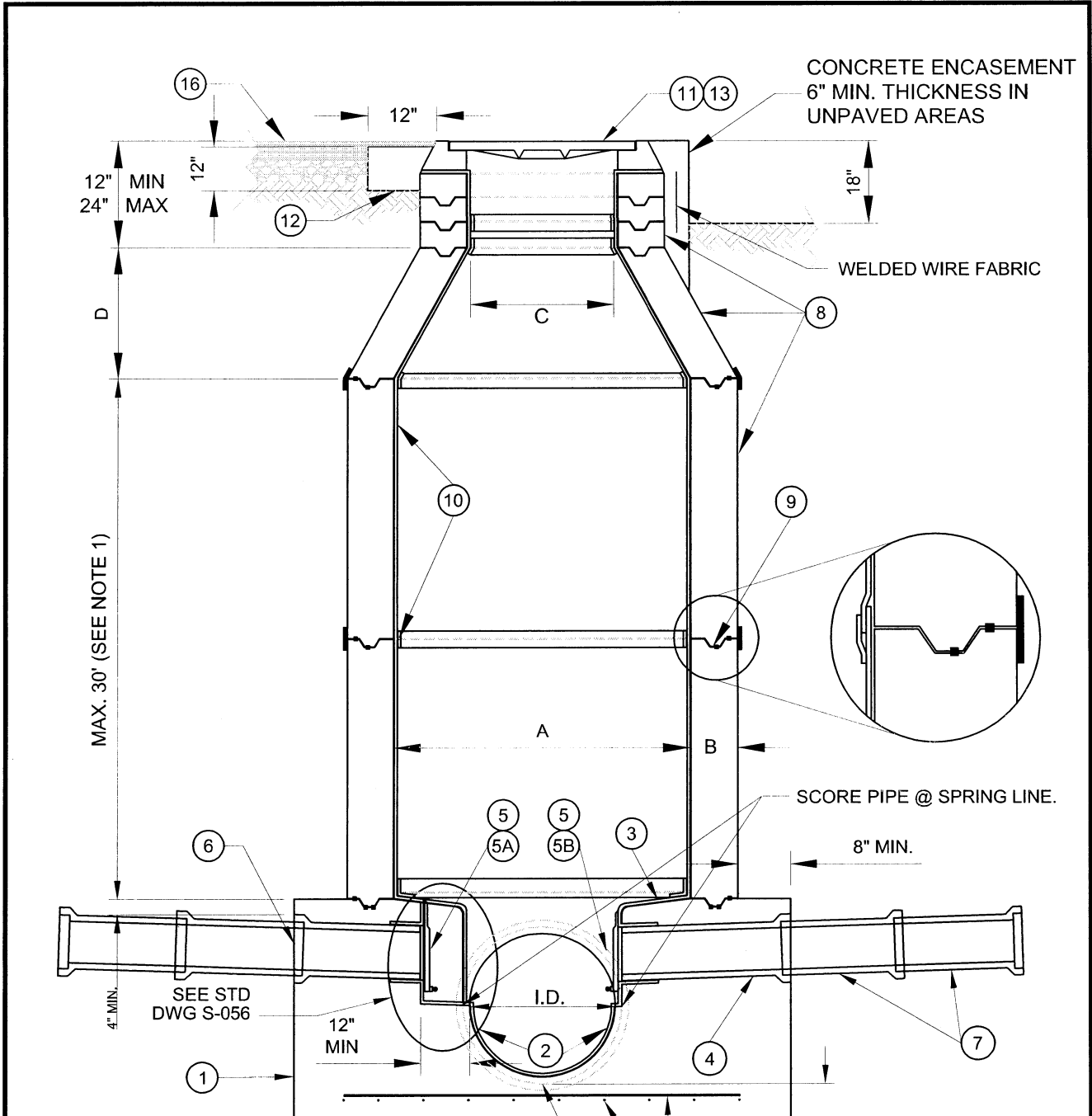

- NOTE:
1. MANHOLE DEPTH GREATER THAN 30', DIMENSION 'A' PER PLANS. SEE PLANS FOR PIPE SIZES OVER 54".
 2. MANHOLE BEDDING SHALL BE MIN. 12" ROCK BEDDING OR APPROVED EQUAL.

PIPE SIZE (I.D.)	A	B	C	D
8"-24"	60"	6"	36"	24"
27"-36"	72"	7"	36"	32"
39"-54"	84"	8"	36"	48"

ELEVATION VIEW A-A
NTS

2	MST	5/07
1	MST	2/07
NO.	APPROVED	DATE

ORANGE COUNTY SANITATION DISTRICT
ORANGE COUNTY, CALIFORNIA
APPROVED BY
Henry 6/20/07
DIRECTOR OF ENGINEERING DATE

NEW PVC LINED
MANHOLE OVER
EXISTING SEWER

1 OF 3
STANDARD DWG.
S-049

049

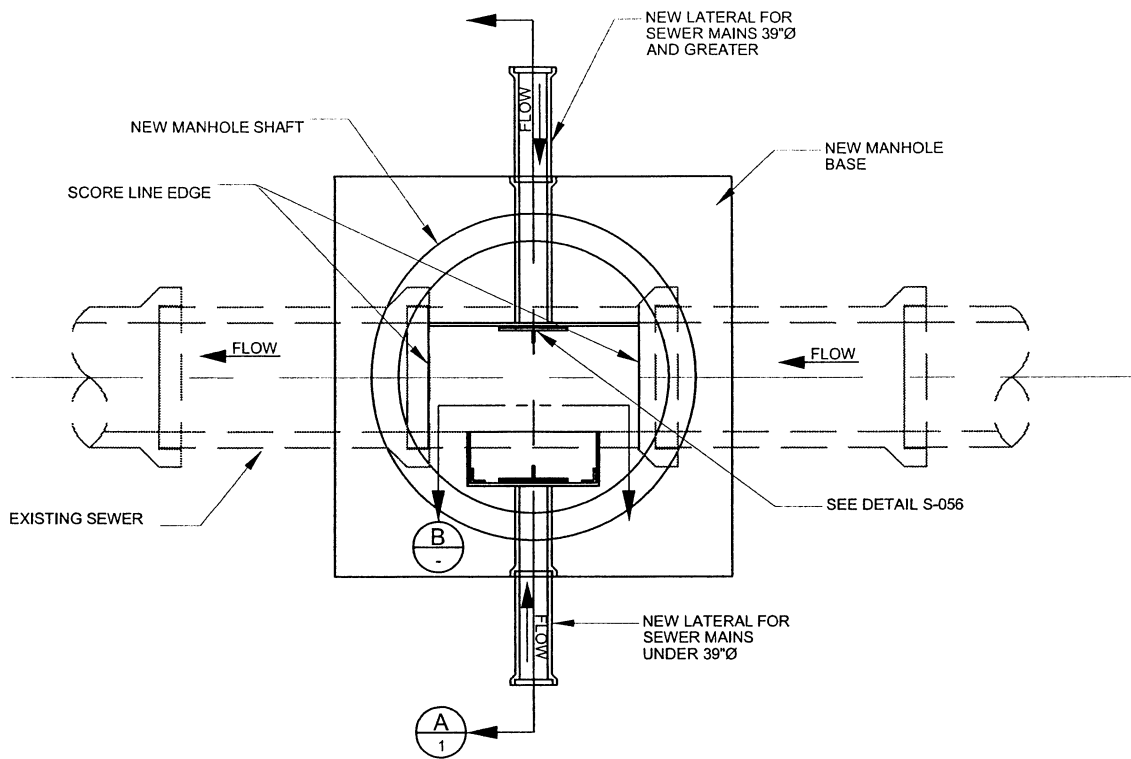

PLAN VIEW
NTS

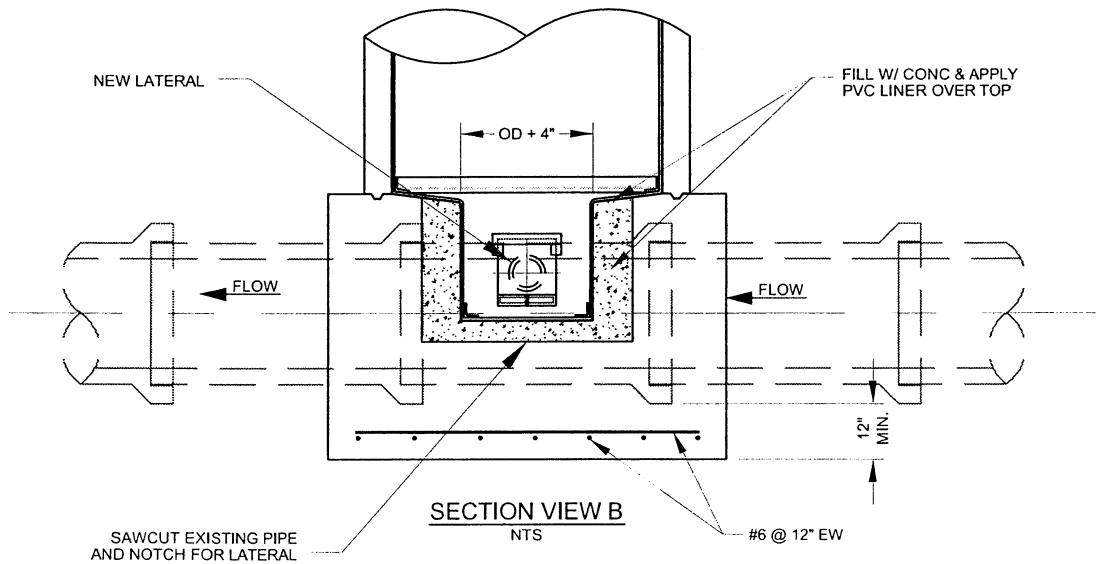

049

NO.	APPROVED	DATE
1	MST	2/07

ORANGE COUNTY SANITATION DISTRICT
ORANGE COUNTY, CALIFORNIA

APPROVED: *Herbay* 06/20/07
DIRECTOR OF ENGINEERING DATE

**NEW PVC LINED
MANHOLE OVER
EXISTING SEWER**

2 OF 3
STANDARD DWG.
S-049

NOTES:

- ① MANHOLES SHALL HAVE 4000 # (CLASS "A"), CONCRETE BASES WITH #6 (19 MM) BARS @ 12" E.W. SIDES OF BASE SHALL BE FORMED BY EITHER WOOD FORMS OR SANDBAGS. BASE MAY BE EITHER CIRCULAR OR RECTANGULAR. IF CIRCULAR, THE AREA SHALL BE EQUAL TO THE AREA OF THE SQUARE BASE. ALL CONCRETE AND MORTAR SHALL USE CLASS II/IV CEMENT.
- ② CONTRACTOR TO SCORE EXISTING MAIN LINE SEWER AT SPRING LINE BEFORE POURING BASE. REMOVAL OF UPPER PART OF EXISTING SEWER SHALL BE DONE AFTER CONCRETE BASE HAS CURED FOR A MINIMUM OF 48 HOURS.
- ③ MANHOLE SHELVES SHALL BE SLOPED 1/4" PER FOOT TO CHANNEL AND COVERED WITH PVC LINER WITH LOCKING EXTENSIONS. THE PVC LINER SHALL BE APPLIED BY MEANS OF AN EPOXY-TYPE MASTIC. INSTALL NON-SKID SURFACE ON PVC LINER OVER THE COMPLETE MANHOLE SHELF ON BOTH SIDES OF MAIN CHANNEL PER THE SPECIFICATION OR APPROVED LINER MANUFACTURER RECOMMENDATIONS. A PVC ANGLE STRIP SHALL BE USED FOR THE TRANSITION BETWEEN HORIZONTAL SHELF AND VERTICAL CHANNEL.
- ④ INSTALL AT LEAST TWO LATERAL INLET PIPES IN THE MANHOLE BASE AS SHOWN. IF NOT SHOWN, LATERAL PIPING SHALL BE 8" VCP AT 90° TO THE MAIN CHANNEL AND SLOPED AT 1/4" PER FOOT FROM THE OUTSIDE OF THE MANHOLE BASE TO THE CHANNEL. WHERE THE CHANNEL ANGLES MORE THAN 45° TOWARD A SIDE, THAT SIDE LATERAL IS NOT REQUIRED.
- ⑤ THE SOFFIT OF ALL LATERAL PIPES SHALL BE AT THE SAME ELEVATION AS THE MAIN PIPE SOFFIT. ALL LATERAL INLETS 12" DIAMETER AND SMALLER SHALL HAVE PVC WELDED GAS FLAPS INSTALLED SIMILAR TO DRAWING S-056, UNLESS OTHERWISE NOTED BY THE ENGINEER. PVC LINER SHALL BE PLACED THROUGHOUT THE CHANNEL AND PVC TURN BACK ON VCP OR OTHER PIPE SHALL BE A MINIMUM OF 6".
- ⑤A FOR MANHOLE BASES WHERE MAIN SEWER PIPE IS LESS THAN 39" IN DIAMETER, THE LATERALS SHALL BE RECESSED 12 INCHES MINIMUM FROM MAIN LINE CHANNEL WITH A TROUGH IN THE BENCH SLOPING TO THE MAIN CHANNEL.
- ⑤B FOR MANHOLE BASES WHERE MAIN SEWER PIPE IS 39" AND GREATER IN DIAMETER, THE END OF THE LATERAL IS FLUSH WITH THE CHANNEL.
- ⑥ ALL UNUSED CONNECTIONS SHALL HAVE A FACTORY MADE VCP PLUG INSTALLED IN THE BELL END OF THE PIPE WITH RESTRAINT SUFFICIENT TO WITHSTAND LEAKAGE TESTING. PIPE OVER 21" SHALL USE A BRICK AND MORTAR PLUG.
- ⑦ EACH MAIN LINE OR LATERAL CONNECTION TO THE MANHOLE BASE SHALL HAVE TWO EACH, TWO FOOT JOINTS.
- ⑧ MANHOLE SECTIONS AND GRADE RINGS SHALL BE REINFORCED, MADE FROM CLASS II/IV CEMENT AND CAST WITH PVC LINER PLATE ON INSIDE. ECCENTRIC CONE SHALL BE SET WITH STRAIGHT SIDE ON DOWNSTREAM SIDE OF MANHOLE. ECCENTRIC REINFORCED CONCRETE FLAT TOPS MAY BE USED WHEN APPROVED BY THE ENGINEER.
- ⑨ THE KEYLOCK JOINT BETWEEN MANHOLE SECTIONS SHALL BE SEALED WITH TWO 1½-INCH SQUARE BEADS OF RAM-NEK BY HENRY COMPANY, KENT-SEAL BY HAMILTON KENT, OR APPROVED EQUAL. THE MASTIC BEADS SHALL BE PLACED ON THE OUTSIDE SHOULDER OF AND IN THE GROOVE. APPLY A 6" MINIMUM WIDTH OUTSIDE JOINT WRAP, RUB'R-NEK BY HENRY COMPANY, SEAL WRAP BY SEALING SYSTEMS, INC., OR EQUAL, TO ALL SHAFT JOINTS. GRADE RING JOINTS SHALL BE MORTAR.
- ⑩ INSTALLATION OF PVC LINER PLATE SHALL CONFORM TO THE REQUIREMENTS OF SECTION 06620 OF THE SPECIFICATIONS. USE WELDING STRIPS AT PVC JOINTS, A PREFORMED CORNER WELDING STRIP AT THE BASE JOINT AND A CONTINUOUS PREFORMED CORNER AT THE TOP GRADE RING AND FRAME JOINT TO THE SECOND GRADE RING.
- ⑪ INSTALL FRAME AND COVER PER STANDARD DRAWING S-055. ADJUSTMENT SHALL OCCUR USING MORTAR BETWEEN FIRST AND SECOND GRADE RINGS. THE FRAME SHALL COMPLETELY BEAR ON PVC. CAULK THE JOINT BETWEEN THE FRAME AND THE PREFORMED PVC CORNER AT THE TOP GRADE RING WITH SIKAFLEX 1A OR EQUAL.
- ⑫ PLACE CONCRETE COLLAR IN PAVED AREAS AS SHOWN AFTER PLACEMENT OF ASPHALT. SEE DRAWING S-055. MANHOLES PLACED IN UNPAVED AREAS SHALL HAVE THE COVERS PLACED 18" ABOVE FINISHED GRADE.
- ⑬ MANHOLES IN INTERSECTIONS SHALL HAVE BOLTED COVERS.
- ⑭ VACUUM TESTING SHALL BE PERFORMED PER ASTM C-1244 UNLESS NOTED OTHERWISE.
- ⑮ MANHOLES SHALL BE BACKFILLED WITH 1 1/2 SACK SAND/CEMENT SLURRY TO STREET ZONE OR AS REQUIRED BY LOCAL AGENCY.
- ⑯ IN PAVED AREAS, PAVEMENT AND BASE COURSE SHALL BE REPLACED IN KIND.

049

			ORANGE COUNTY SANITATION DISTRICT ORANGE COUNTY, CALIFORNIA	NEW PVC LINED MANHOLE OVER EXISTING SEWER	3 OF 3
2	MST	5/07	APPROVED BY		STANDARD DWG.
1	MST	2/07	<i>[Signature]</i> 06/20/07		S-049
NO.	APPROVED	DATE	DIRECTOR OF ENGINEERING	DATE	

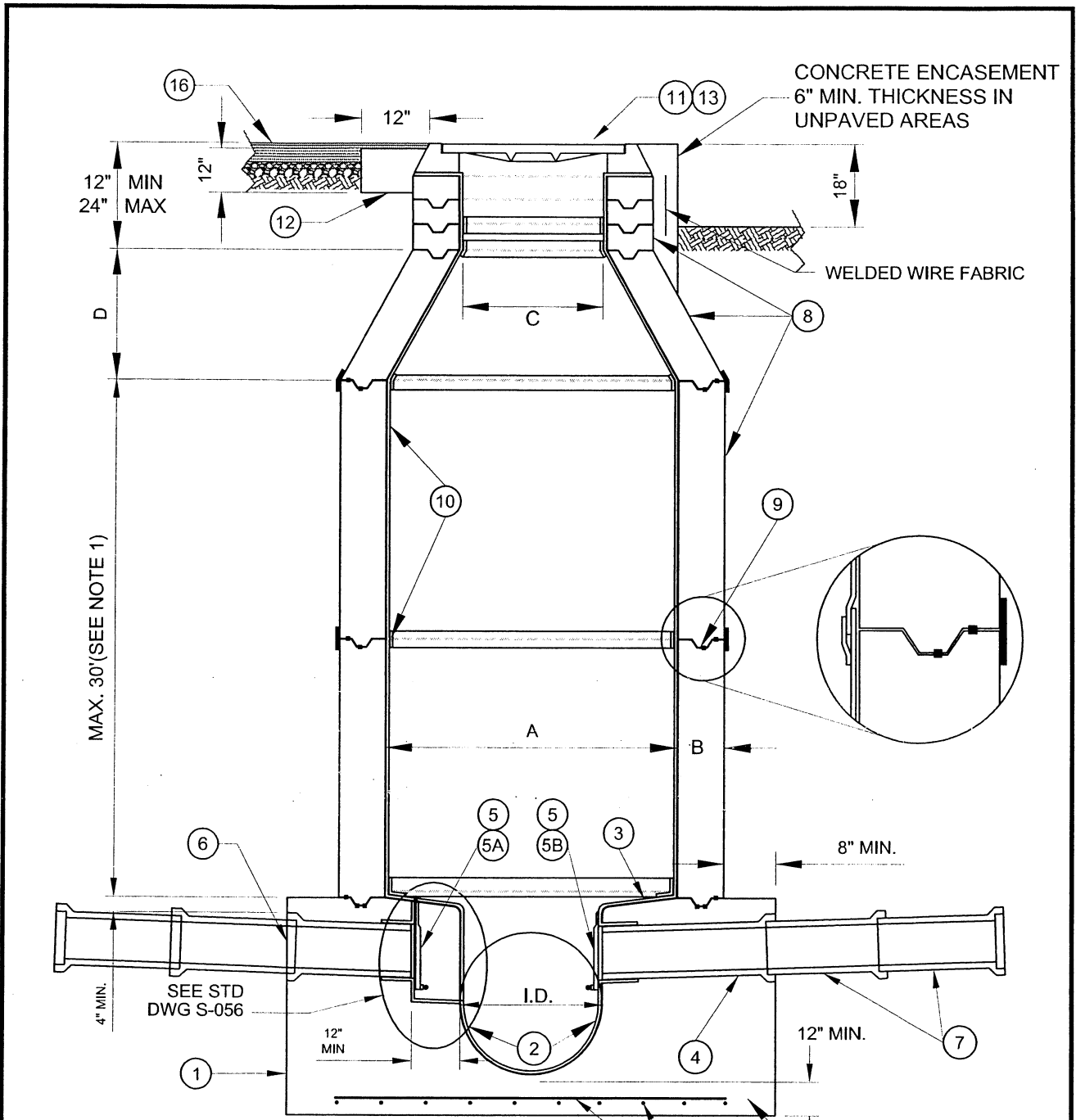

- NOTE:
1. MANHOLE DEPTH GREATER THAN 30', DIMENSION 'A' PER PLANS. SEE PLANS FOR PIPE SIZES OVER 54".
 2. MANHOLE BEDDING SHALL BE THE SAME THICKNESS AND CLASS AS THE PIPE BEDDING.

PIPE SIZE (I.D.)	A	B	C	D
8"-24"	60"	6"	36"	24"
27"-36"	72"	7"	36"	32"
39"-54"	84"	8"	36"	48"

ELEVATION VIEW A-A
NTS

050

NO.	APPROVED	DATE
1	MST	2/07

ORANGE COUNTY SANITATION DISTRICT
ORANGE COUNTY, CALIFORNIA

APPROVED BY
A. Serbay 06/20/07
DIRECTOR OF ENGINEERING

NEW PVC LINED
MANHOLE FOR
NEW SEWERS

1 OF 3
STANDARD DWG.
S-050

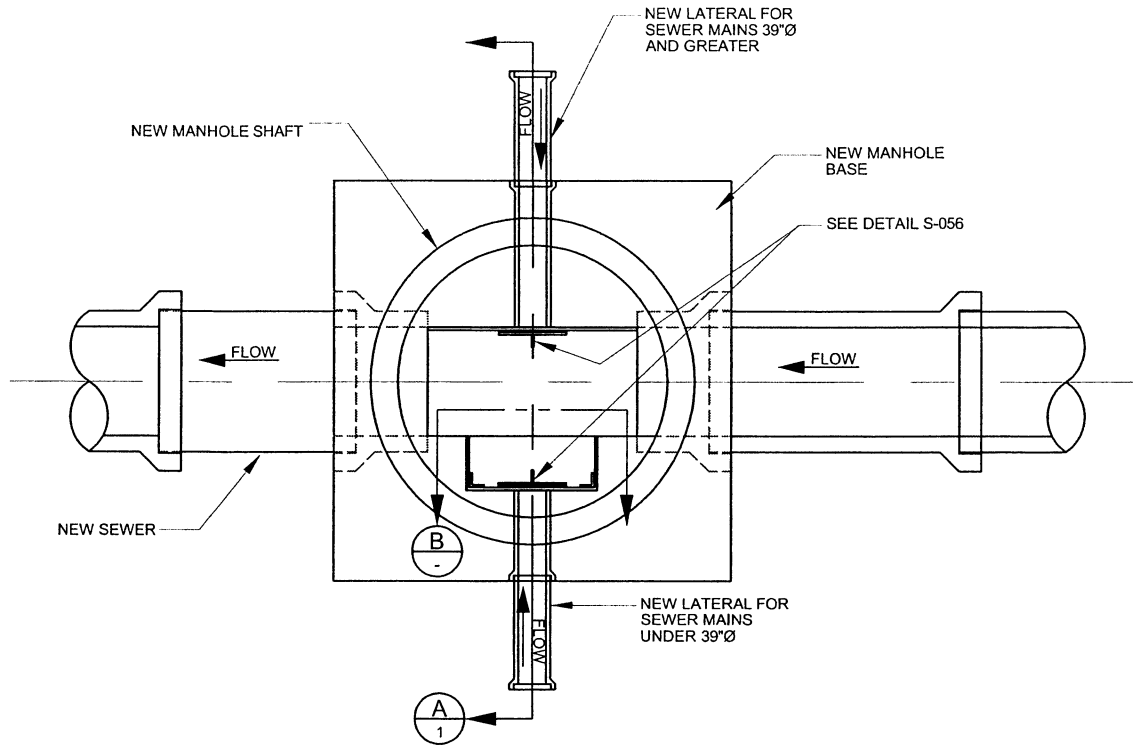

PLAN VIEW
NTS

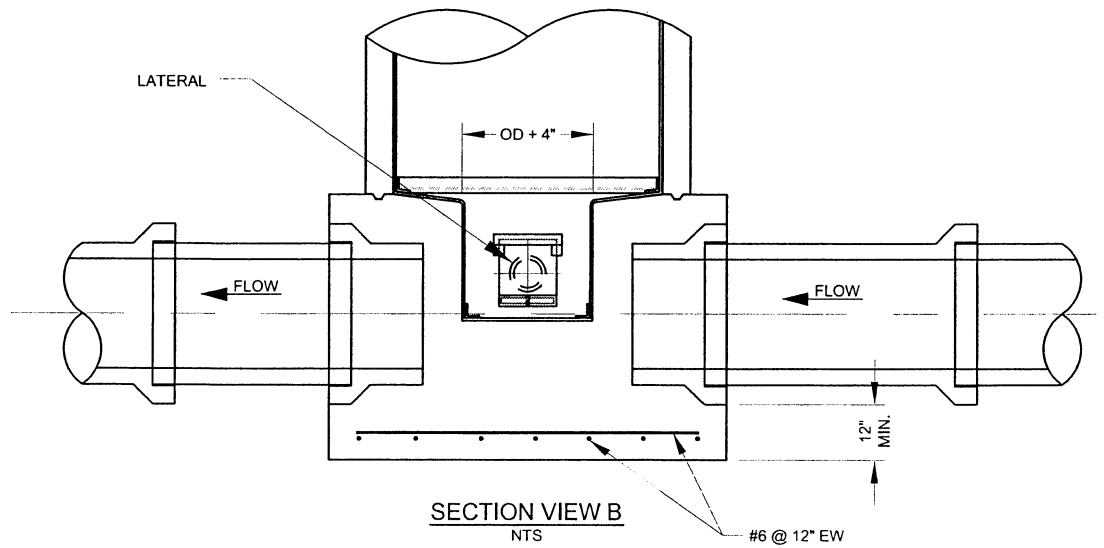

SECTION VIEW B
NTS

050

NO.	APPROVED	DATE
1	MST	2/07

ORANGE COUNTY SANITATION DISTRICT
ORANGE COUNTY, CALIFORNIA

APPROVED BY

A. Sabay 06/20/07
DIRECTOR OF ENGINEERING DATE

NEW PVC LINED
MANHOLE FOR
NEW SEWER

2 OF 3

STANDARD DWG.

S-050

NOTES:

- ① MANHOLES SHALL HAVE 4000 # (CLASS "A"), CONCRETE BASES WITH #6 (19 MM) BARS @ 12" E.W. SIDES OF BASE SHALL BE FORMED BY EITHER WOOD FORMS OR SANDBAGS. BASE MAY BE EITHER CIRCULAR OR RECTANGULAR. IF CIRCULAR, THE AREA SHALL BE EQUAL TO THE AREA OF THE SQUARE BASE. ALL CONCRETE AND MORTAR SHALL USE CLASS II/V CEMENT.
- ② THE COMPLETE CONCRETE CHANNEL SHALL BE CONSTRUCTED WITH FORMS AND PVC LINED. WHERE PVC LINED RCP IS USED, THE CHANNEL LINING IS TO BE INSTALLED TO THE SAME DEPTH AS THE RCP LINING. WHEN APPROVED BY THE ENGINEER, THE NEW OR EXISTING MAIN LINE MAY BE USED FOR THE CHANNEL. PIPE ABOVE SPRING LINE SHALL BE REMOVED BY SAW CUTTING. THE REMOVED SECTION LENGTH SHALL BE EQUAL TO THE MANHOLE SHAFT INSIDE DIAMETER.
- ③ MANHOLE SHELVES SHALL BE SLOPED 1/4" PER FOOT TO CHANNEL AND COVERED WITH PVC LINER WITH LOCKING EXTENSIONS. THE PVC LINER SHALL BE APPLIED BY MEANS OF AN EPOXY-TYPE MASTIC. INSTALL NON-SKID SURFACE ON PVC LINER OVER THE COMPLETE MANHOLE SHELF ON BOTH SIDES OF MAIN CHANNEL PER THE SPECIFICATION OR APPROVED LINER MANUFACTURER RECOMMENDATIONS. A PVC ANGLE STRIP SHALL BE USED FOR THE TRANSITION BETWEEN HORIZONTAL SHELF AND VERTICAL CHANNEL.
- ④ INSTALL AT LEAST TWO LATERAL INLET PIPES IN THE MANHOLE BASE AS SHOWN. IF NOT SHOWN, LATERAL PIPING SHALL BE 8" VCP AT 90° TO THE MAIN CHANNEL AND SLOPED AT 1/4" PER FOOT FROM THE OUTSIDE OF THE MANHOLE BASE TO THE CHANNEL. WHERE THE CHANNEL ANGLES MORE THAN 45° TOWARD A SIDE, THAT SIDE LATERAL IS NOT REQUIRED.
- ⑤ THE SOFFIT OF ALL LATERAL PIPES SHALL BE AT THE SAME ELEVATION AS THE MAIN PIPE SOFFIT. ALL LATERAL INLETS 12" DIAMETER AND SMALLER SHALL HAVE PVC WELDED GAS FLAPS INSTALLED SIMILAR TO DRAWING S-056, UNLESS OTHERWISE NOTED BY THE ENGINEER. PVC LINER SHALL BE PLACED THROUGHOUT THE CHANNEL AND PVC TURN BACK ON VCP OR OTHER PIPE SHALL BE A MINIMUM OF 6".
- ⑤A FOR MANHOLE BASES WHERE MAIN SEWER PIPE IS LESS THAN 39" IN DIAMETER, THE LATERALS SHALL BE RECESSED 12 INCHES MINIMUM FROM MAIN LINE CHANNEL WITH A TROUGH IN THE BENCH SLOPING TO THE MAIN CHANNEL.
- ⑤B FOR MANHOLE BASES WHERE MAIN SEWER PIPE IS 39" AND GREATER IN DIAMETER, THE END OF THE LATERAL IS FLUSH WITH THE CHANNEL.
- ⑥ ALL UNUSED CONNECTIONS SHALL HAVE A FACTORY MADE VCP PLUG INSTALLED IN THE BELL END OF THE PIPE WITH RESTRAINT SUFFICIENT TO WITHSTAND LEAKAGE TESTING. PIPE OVER 21" SHALL USE A BRICK AND MORTAR PLUG.
- ⑦ EACH MAIN LINE OR LATERAL CONNECTION TO THE MANHOLE BASE SHALL HAVE TWO EACH, TWO FOOT JOINTS.
- ⑧ MANHOLE SECTIONS AND GRADE RINGS SHALL BE REINFORCED, MADE FROM CLASS II/V CEMENT AND CAST WITH PVC LINER PLATE ON INSIDE. ECCENTRIC CONE SHALL BE SET WITH STRAIGHT SIDE ON DOWNSTREAM SIDE OF MANHOLE. ECCENTRIC REINFORCED CONCRETE FLAT TOPS MAY BE USED WHEN APPROVED BY THE ENGINEER.
- ⑨ THE KEYLOCK JOINT BETWEEN MANHOLE SECTIONS SHALL BE SEALED WITH TWO 1¼-INCH SQUARE BEADS OF RAM-NEK BY HENRY COMPANY, KENT-SEAL BY HAMILTON KENT, OR APPROVED EQUAL. THE MASTIC BEADS SHALL BE PLACED ON THE OUTSIDE SHOULDER OF AND IN THE GROOVE. APPLY A 6" MINIMUM WIDTH OUTSIDE JOINT WRAP, RUB'R-NEK BY HENRY COMPANY, SEAL WRAP BY SEALING SYSTEMS, INC., OR EQUAL, TO ALL SHAFT JOINTS. GRADE RING JOINTS SHALL BE MORTAR.
- ⑩ INSTALLATION OF PVC LINER PLATE SHALL CONFORM TO THE REQUIREMENTS OF SECTION 06620 OF THE SPECIFICATIONS. USE WELDING STRIPS AT PVC JOINTS, A PREFORMED CORNER WELDING STRIP AT THE BASE JOINT AND A CONTINUOUS PREFORMED CORNER AT THE TOP GRADE RING AND FRAME JOINT TO THE SECOND GRADE RING.
- ⑪ INSTALL FRAME AND COVER PER STANDARD DRAWING S-055. ADJUSTMENT SHALL OCCUR USING MORTAR BETWEEN FIRST AND SECOND GRADE RINGS. THE FRAME SHALL COMPLETELY BEAR ON PVC. CAULK THE JOINT BETWEEN THE FRAME AND THE PREFORMED PVC CORNER AT THE TOP GRADE RING WITH SIKAFLEX 1A OR EQUAL.
- ⑫ PLACE CONCRETE COLLAR IN PAVED AREAS AS SHOWN AFTER PLACEMENT OF ASPHALT. SEE DRAWING S-055. MANHOLES PLACED IN UNPAVED AREAS SHALL HAVE THE COVERS PLACED 18" ABOVE FINISHED GRADE.
- ⑬ MANHOLES IN INTERSECTIONS SHALL HAVE BOLTED COVERS.
- ⑭ VACUUM TESTING SHALL BE PERFORMED PER ASTM C-1244 UNLESS NOTED OTHERWISE.
- ⑮ MANHOLES SHALL BE BACKFILLED WITH 1 1/2 SACK SAND/CEMENT SLURRY TO STREET ZONE OR AS REQUIRED BY LOCAL AGENCY.
- ⑯ IN PAVED AREAS, PAVEMENT AND BASE COURSE SHALL BE REPLACED IN KIND.

050

			ORANGE COUNTY SANITATION DISTRICT ORANGE COUNTY, CALIFORNIA	NEW PVC LINED MANHOLE FOR NEW SEWERS	3 OF 3
			APPROVED BY <i>[Signature]</i>		STANDARD DWG.
1	MST	2/07	<i>[Signature]</i>		S-050
NO.	APPROVED	DATE	DIRECTOR OF ENGINEERING	DATE	

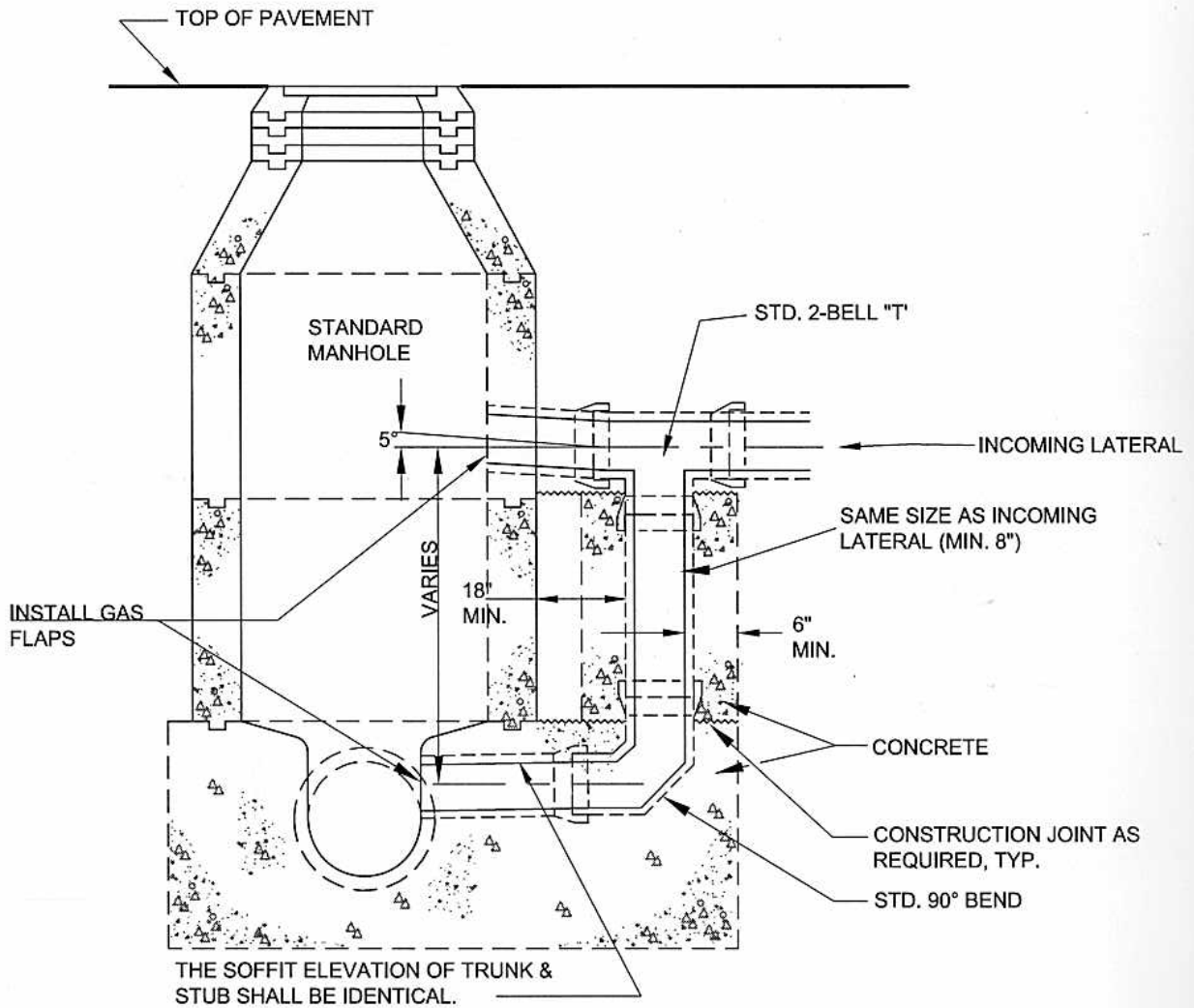

NOTES:

1. SEE DETAIL S-050 FOR STANDARD MANHOLE.
2. CONCRETE FOR DROP SECTIONS SHALL BE FORMED.
3. ALL MANHOLE PENETRATIONS SHALL BE MADE BY CORE DRILLING. INTERIOR COATING SHALL BE REPAIRED. PVC LINER SHALL BE REPAIRED WITH 6" TURN BACK AT ALL PENETRATIONS. GAS FLAPS SHALL BE INSTALLED AT ALL PENETRATIONS 12" OR SMALLER (SEE STD. DRAWING S-056).
4. DROP MANHOLE CONNECTION SHALL BE USED ONLY WHERE SLOPE OF LATERAL INCOMING TO MAIN SEWER WOULD EXCEED 10% AND ONLY WITH APPROVAL OF THE ENGINEER.

051

			ORANGE COUNTY SANITATION DISTRICT ORANGE COUNTY, CALIFORNIA	DROP MANHOLE CONNECTION TO STANDARD MANHOLE	NO SCALE
			APPROVED BY <i>James Huber</i>		STANDARD DWG.
1	AN	4/12	<i>James Huber</i> DIRECTOR OF ENGINEERING	10-04-2012	S-051
1	CFW	6/06			
NO.	APPROVED	DATE			

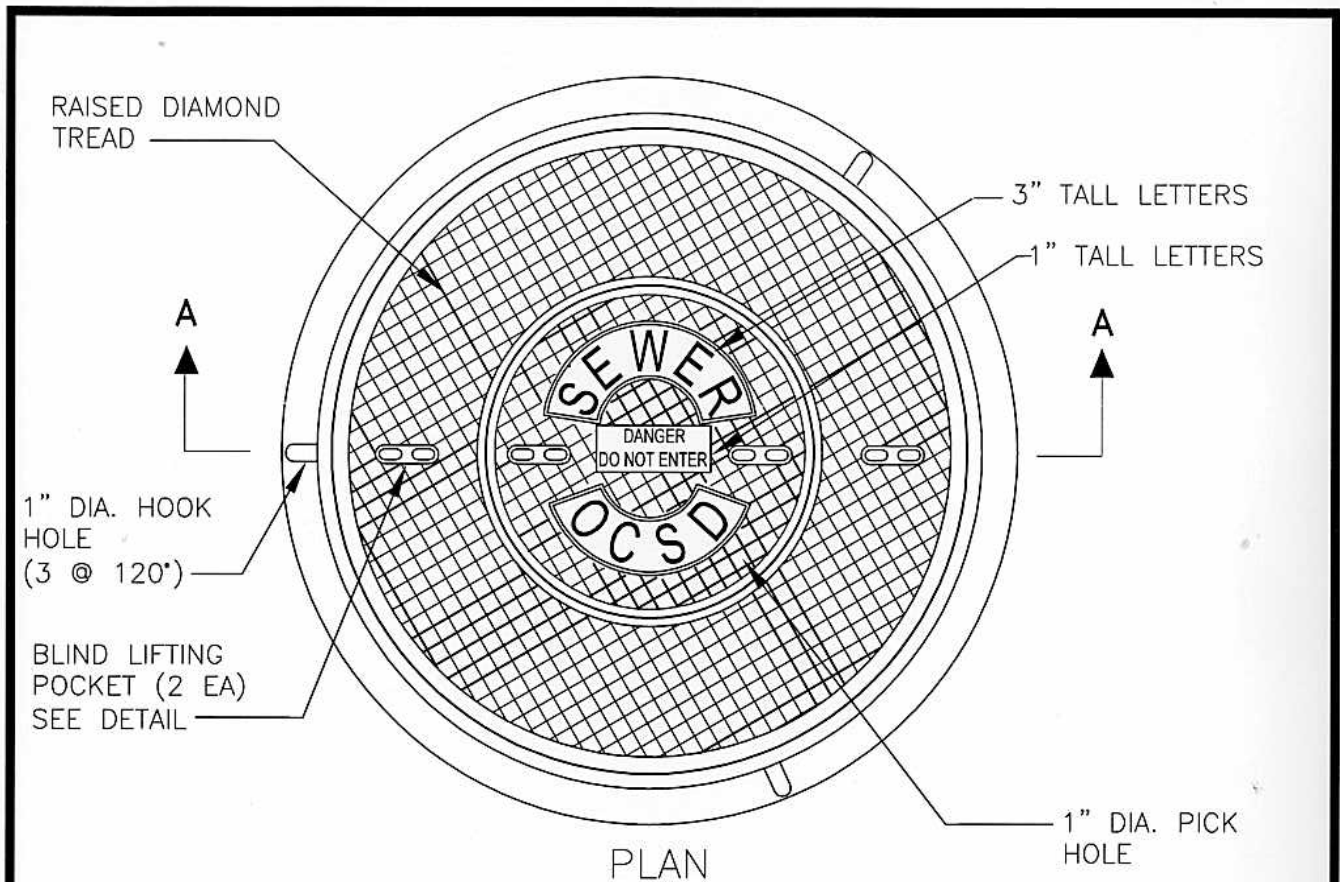

PLAN

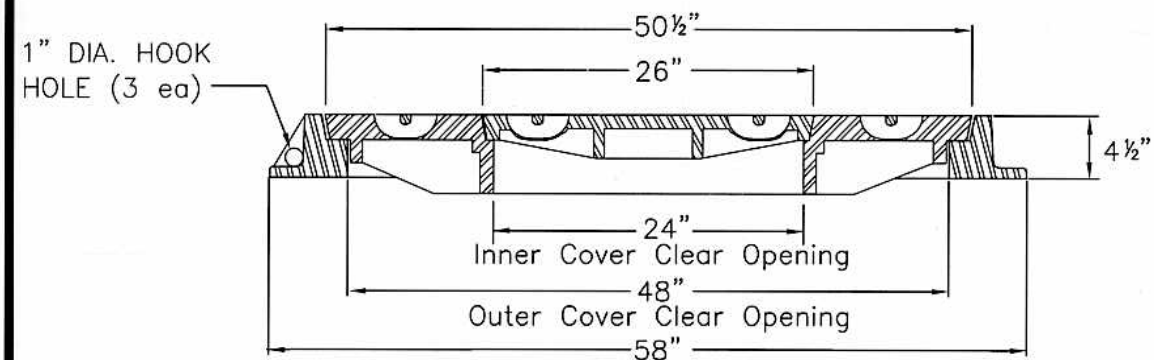

Overall Diameter
SECTION A-A

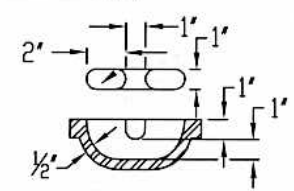

BLIND LIFTING POCKET DETAIL

NOTE:

1. COVERS SHALL BE TRAFFIC GRADE.
2. ALL CASTINGS SHALL BE COMPLETELY PAINTED WITH 6 MILS. BITUMINOUS PAINT AND LETTERED "MADE IN COUNTRY OF ORIGIN", MARKED WITH MANUFACTURER'S IDENTIFICATION "HEAT NO. _____", "ASTM A-48", AND "CLASS 35B IRON" ON UNDERSIDE OF COVER. WEIGHT OF INNER 24" COVER SHALL BE 190 LBS. MIN., WEIGHT OF OUTER 48" COVER SHALL BE 600 LBS. MIN. AND WEIGHT OF FRAME SHALL BE 600 LBS. MIN. ACTUAL WEIGHTS SHALL BE +/- 5 PERCENT OF THE MINIMUM.
3. THIS DRAWING FOR UNBOLTED 48" MANHOLE COVERS WITH CONCENTRIC 24" COVER ONLY.
4. PROVIDE 6" RIM IF REQUIRED FOR ADJUSTMENT TO GRADE.
5. THE GAP BETWEEN THE COVER AND THE RING SHALL BE APPROXIMATELY 1/8" AROUND THE ENTIRE CIRCUMFERENCE AND SHALL NOT BE GREATER THAN 1/4" WHEN THE COVER IS SLID TO ONE SIDE.

058

		ORANGE COUNTY SANITATION DISTRICT ORANGE COUNTY, CALIFORNIA		48" MANHOLE FRAME AND COVER WITH CONCENTRIC 24" COVER		NO SCALE	
		APPROVED BY <i>James Holby</i> 05-16-2011				STANDARD DWG. S-052	
NO.	APPROVED	DATE	DIRECTOR OF ENGINEERING	DATE			

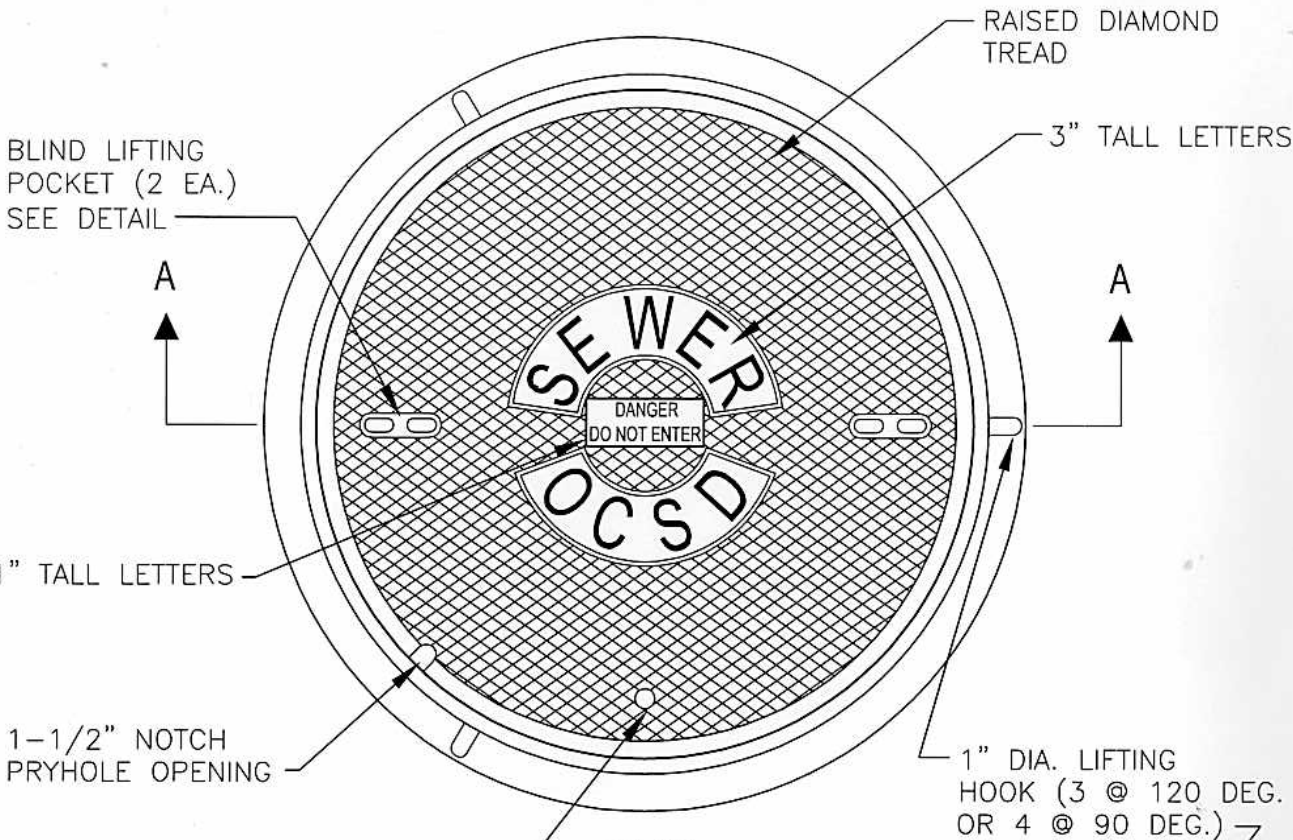

PLAN

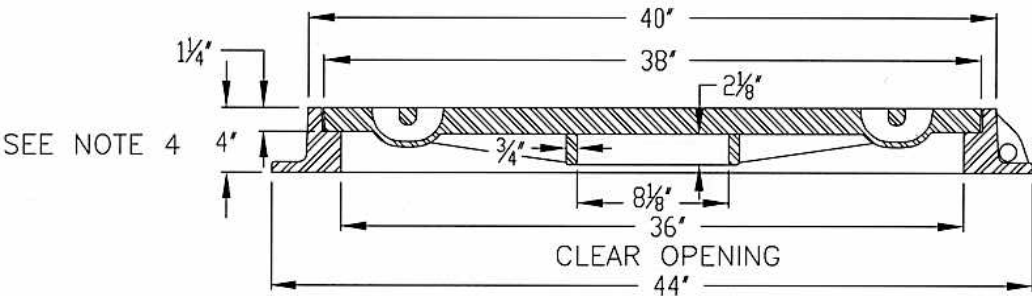

SECTION A-A

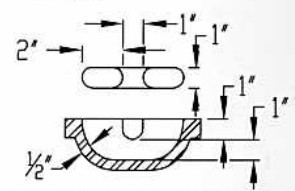

BLIND LIFTING POCKET DETAIL

NOTE:

1. COVERS SHALL BE TRAFFIC GRADE.
2. ALL CASTINGS SHALL BE COMPLETELY PAINTED WITH 6 MILS. BITUMINOUS PAINT AND LETTERED "MADE IN COUNTRY OF ORIGIN", MARKED WITH MANUFACTURER'S IDENTIFICATION "HEAT NO. _____", "ASTM A-48", AND "CLASS 35B IRON" ON UNDERSIDE OF COVER. WEIGHT OF COVER SHALL BE 325 LBS. MIN., WEIGHT OF FRAME SHALL BE 270 LBS. MIN. ACTUAL WEIGHTS SHALL BE +/- 5 PERCENT OF THE MINIMUM.
3. THIS DRAWING FOR UNBOLTED "STANDARD" MANHOLE COVERS ONLY. BOLTED COVERS, SHOWN ON A SEPARATE DRAWING, SHALL BE INSTALLED AT ALL INTERSECTIONS.
4. PROVIDE 6" RIM IF REQUIRED FOR ADJUSTMENT TO GRADE.
5. THE GAP BETWEEN THE COVER AND THE RING SHALL BE APPROXIMATELY 1/8" AROUND THE ENTIRE CIRCUMFERENCE AND SHALL NOT BE GREATER THAN 1/4" WHEN THE COVER IS SLID TO ONE SIDE.

053_2

			ORANGE COUNTY SANITATION DISTRICT ORANGE COUNTY, CALIFORNIA	STANDARD MANHOLE FRAME AND COVER	NO SCALE
3	MST	8/10	APPROVED BY <i>James Herberg</i> 05-10-2011 DIRECTOR OF ENGINEERING		STANDARD DWG.
2	MST	11/07			
1	MST	2/07			
NO.	APPROVED	DATE			S-053

ALIGNMENT MARKS
(BOLTED COVERS ONLY)

RAISED DIAMOND
TREAD

3" TALL LETTERS

1" TALL LETTERS

A

A

BLIND LIFTING
POCKET (2 EA)
SEE DETAIL

BOLTED COVER
8 PLACES (TYP.)

SEWER
DANGER
DO NOT ENTER
OCSD

1" DIA. LIFTING
HOOK (3 @ 120 DEG.
OR 4 @ 90 DEG.)

1/2" X 1 1/2" TYPE 316 S.S.
HEX HEAD MB. USE WITH
1/8" X 1" RUBBER GASKET
GLUED TO FRAME

PLAN

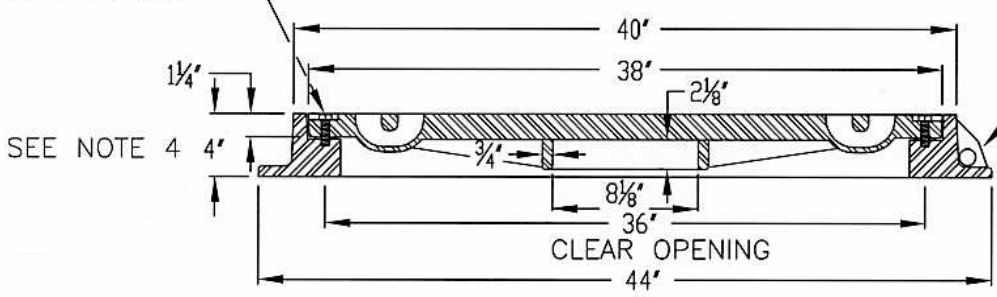

SECTION A-A

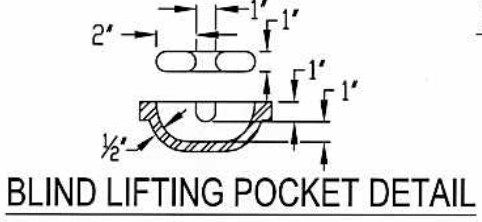

BLIND LIFTING POCKET DETAIL

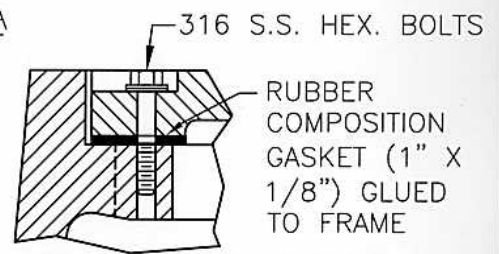

BOLTING/Self-SEAL DETAIL

NOTE:

1. COVERS SHALL BE TRAFFIC GRADE.
2. ALL CASTINGS SHALL BE COMPLETELY PAINTED WITH 6 MILS. BITUMINOUS PAINT AND LETTERED "MADE IN COUNTRY OF ORIGIN", MARKED WITH MANUFACTURER'S IDENTIFICATION "HEAT NO. ____", "ASTM A-48", AND "CLASS 35B IRON" ON UNDERSIDE OF COVER. WEIGHT OF COVER SHALL BE 325 LBS. MIN., WEIGHT OF FRAME SHALL BE 270 LBS. MIN. ACTUAL WEIGHTS SHALL BE +/- 5 PERCENT OF THE MINIMUM.
3. BOLTED COVERS SHALL BE INSTALLED AT ALL INTERSECTIONS.
4. PROVIDE 6" RIM IF REQUIRED FOR ADJUSTMENT TO GRADE.
5. THE GAP BETWEEN THE COVER AND THE RING SHALL BE APPROXIMATELY 1/8" AROUND THE ENTIRE CIRCUMFERENCE AND SHALL NOT BE GREATER THAN 1/4" WHEN THE COVER IS SLID TO ONE SIDE.

3	MST	8/10
2	MST	11/07
1	MST	2/07
NO.	APPROVED	DATE

ORANGE COUNTY SANITATION DISTRICT
ORANGE COUNTY, CALIFORNIA
APPROVED BY
James H. ... 05-16-2011
DIRECTOR OF ENGINEERING DATE

BOLTED MANHOLE
FRAME AND COVER

NO SCALE
STANDARD DWG.
S-054

054

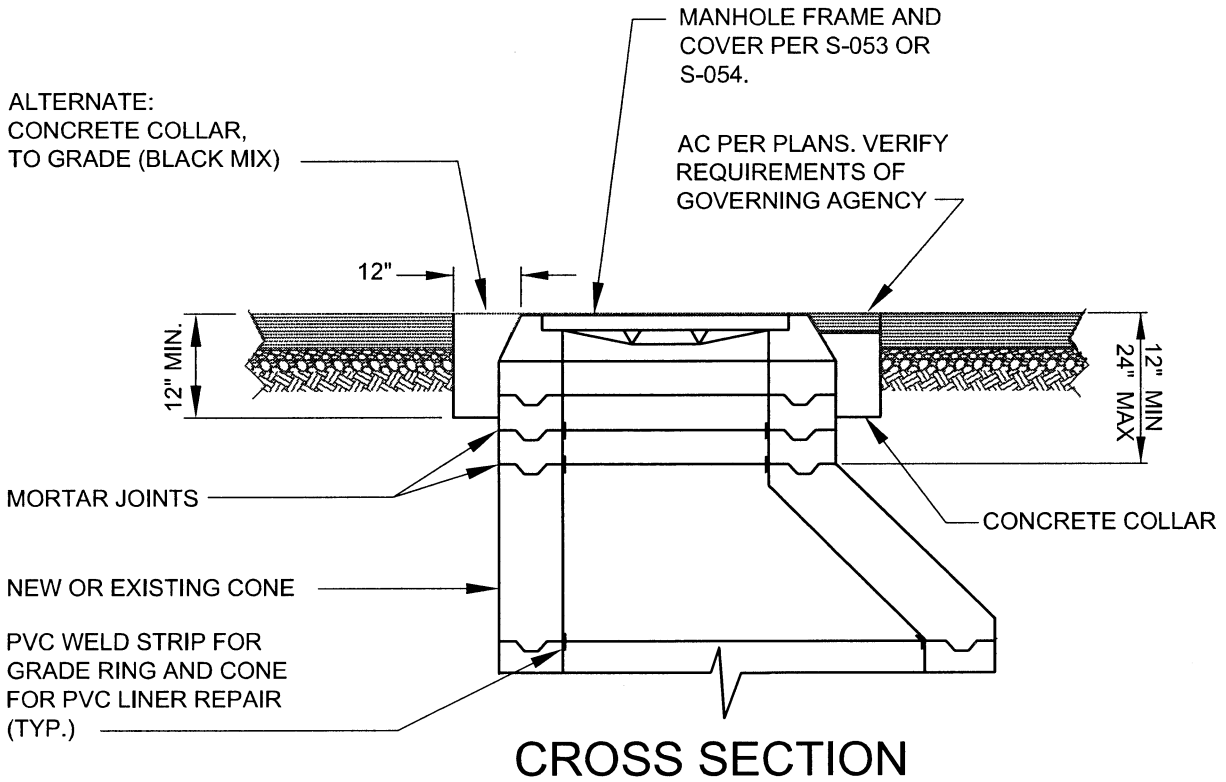

CROSS SECTION

NOTES:

1. Neatly remove pavement and aggregate base as necessary to make adjustment.
2. Make final adjustments at the mortar joint between the first and second grade rings. Set flush with pavement to one-eighth inch high.
3. At existing manholes, add or remove grade rings, repair PVC or sprayed liner, and test liner for pinholes as approved by the Engineer. Adjust height at manhole riser sections if the total height of grade rings would exceed 24 inches.
4. Backfill flush with surface or below pavement surface as required by governing agency with 3250 psi (Class B) quick-setting concrete to form collar. Exposed concrete shall be black in color.
5. Fill area above below-grade collar with AC wearing surface to match adjacent AC.
6. Where odor conditions exist or where designated, seal manhole rim and holes with duct-seal mastic. Re-seal if existing manhole cover was sealed.

			ORANGE COUNTY SANITATION DISTRICT ORANGE COUNTY, CALIFORNIA	MANHOLE ADJUSTMENT TO GRADE	NO SCALE
			APPROVED BY <i>Ala Bay</i> 06/24/07 DIRECTOR OF ENGINEERING		STANDARD DWG. S-055
NO.	APPROVED	DATE			

055

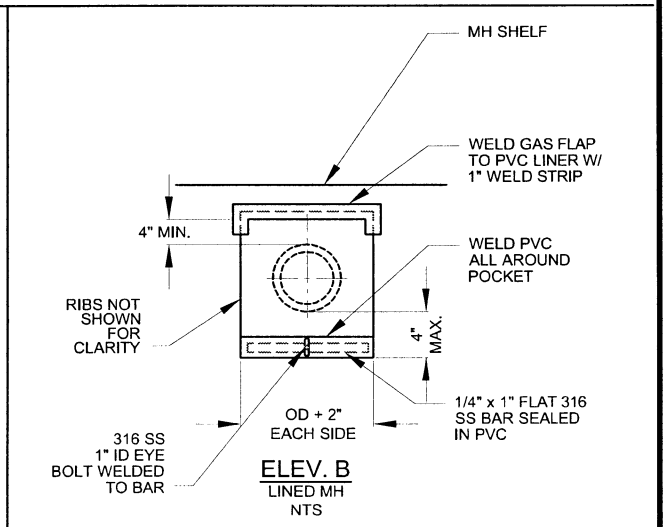
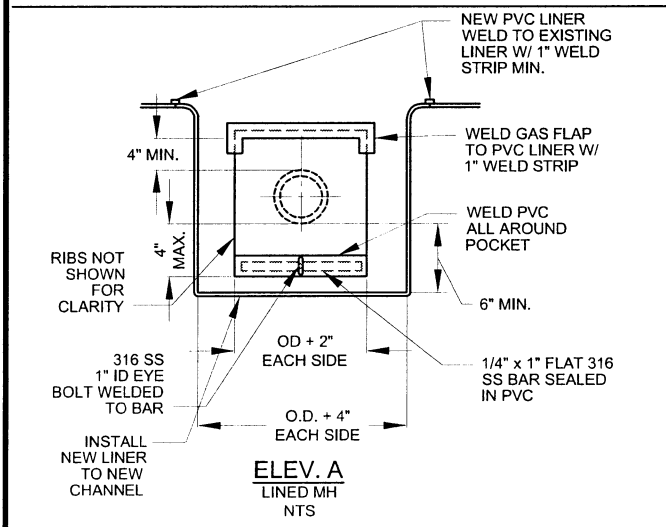
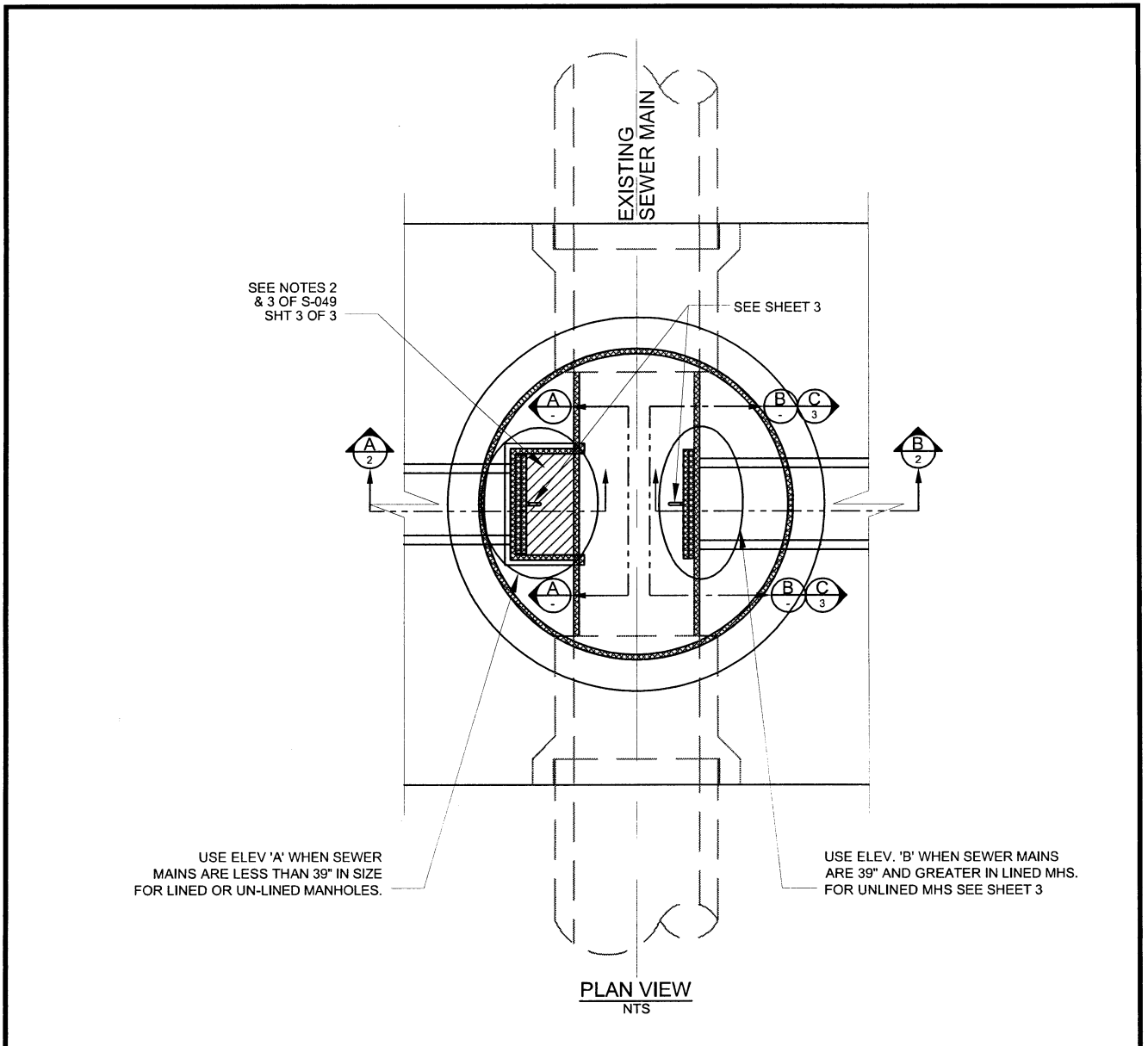

056

NO.	APPROVED	DATE
1	MST	2/07

ORANGE COUNTY SANITATION DISTRICT
ORANGE COUNTY, CALIFORNIA

APPROVED BY: *[Signature]* 06/20/07
DIRECTOR OF ENGINEERING DATE

**GAS FLAP INSTALLATION
FOR PVC LINED OR UNLINED
MANHOLES**

1 OF 3
STANDARD DWG.
S-056

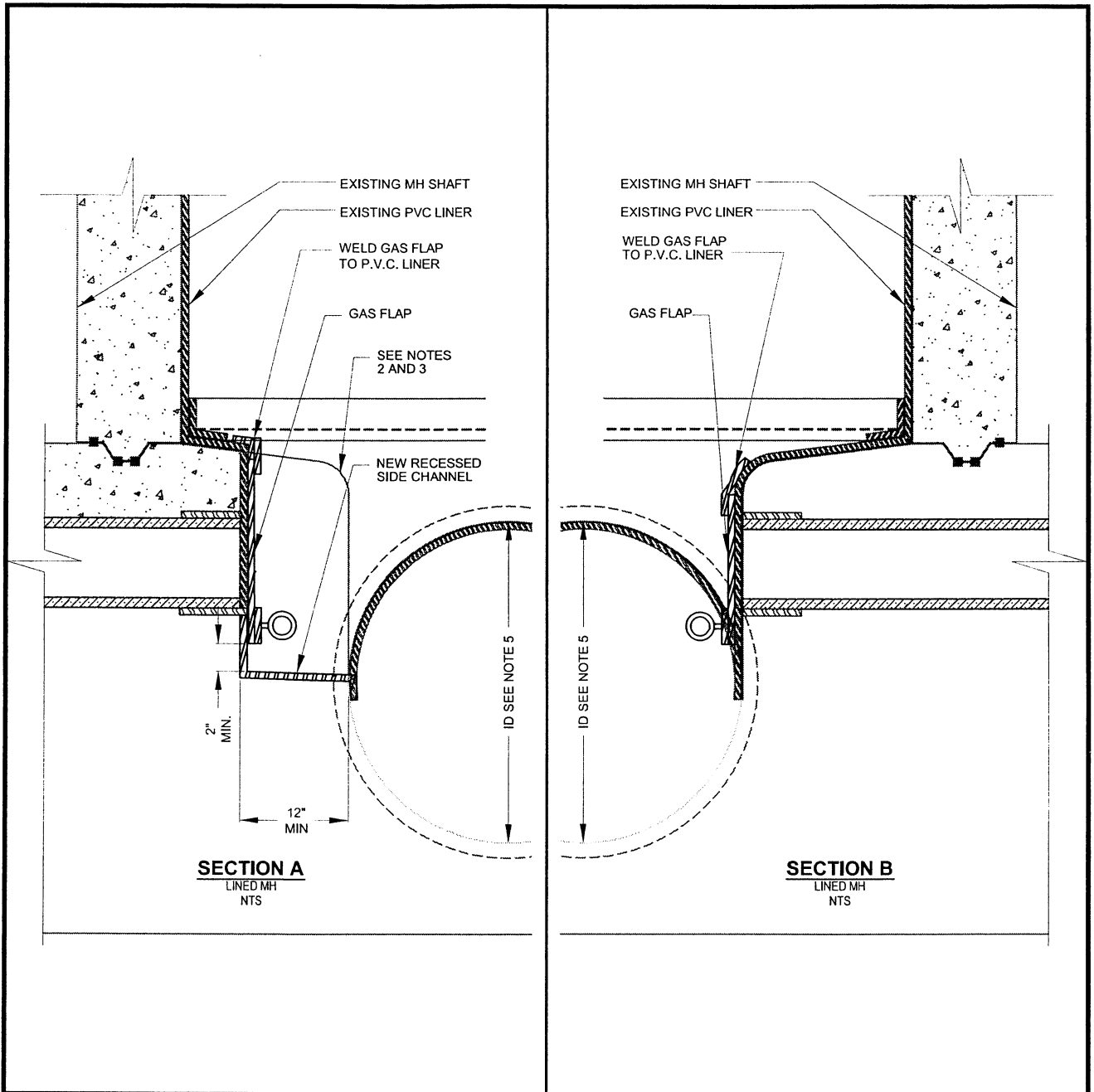

NOTE:

1. CORE DRILL EXISTING MH BASE A MIN. OF 2 INCHES LARGER THAN OUTSIDE DIAMETER (OD) OF NEW VCP STUB AND DRY PACK W/ CONCRETE GROUT AROUND OUTSIDE OF NEW VCP STUB AS SHOWN.
2. REMOVE EXISTING PVC LINER OVER EXISTING MH SHELF. JACK HAMMER OR REMOVE PORTIONS OF EXISTING CONCRETE BASE TO FORM NEW RECESSED CHANNEL A MIN. OF 2 INCHES IN WIDTH (ON EACH SIDE) BEYOND EDGE OF NEW GAS FLAP; OR FOR NEW VCP STUBS 15 INCHES OR GREATER IN DIAMETER, REMOVE A MIN. 4 INCHES IN WIDTH (ON EACH SIDE) GREATER THAN OD OF NEW VCP STUB. PATCH BOTTOM AND SIDES OF RECESSED CHANNEL W/ CONCRETE OR GROUT TO MAKE A SMOOTH TRANSITION ON SIDES AND BOTTOM OF CHANNEL.
3. INSTALL NEW MASTIC APPLIED AND MECHANICALLY ANCHORED PVC LINER IN RECESSED CHANNEL AREA OVER FRESHLY CURED CONCRETE AND IN ALL OTHER AREAS WHERE EXISTING PVC LINER WAS REMOVED. PVC WELD STRIPS SHALL BE USED TO PATCH ALL PVC JOINTS.
4. PROVIDE PVC GAS FLAP ON ALL LATERAL PIPES 12 INCHES IN DIA. AND LESS UNLESS OTHERWISE SPECIFIED.
5. WHEN TRUNK LINE PIPE IS EQUAL TO OR GREATER THAN 39 INCHES IN DIAMETER, LATERAL PIPE SHALL EXTEND TO VERTICAL FACE OF MAIN CHANNEL WITHOUT HAVING A RECESSED SIDE CHANNEL.

056

NO.	APPROVED	DATE
1	MST	2/07

ORANGE COUNTY SANITATION DISTRICT
ORANGE COUNTY, CALIFORNIA

APPROVED BY: *Herbert* 06/20/07
DIRECTOR OF ENGINEERING DATE

**GAS FLAP INSTALLATION
FOR PVC LINED OR UNLINED
MANHOLES**

2 OF 3
STANDARD DWG.
S-056

PLACE RIBBED PVC SHEET GAS FLAP ON OUTSIDE OF LATERAL OPENING

PVC RIBS NOT SHOWN FOR CLARITY

316 SS 1" ID EYE BOLTS WELDED TO SS BAR SEE DETAIL 2

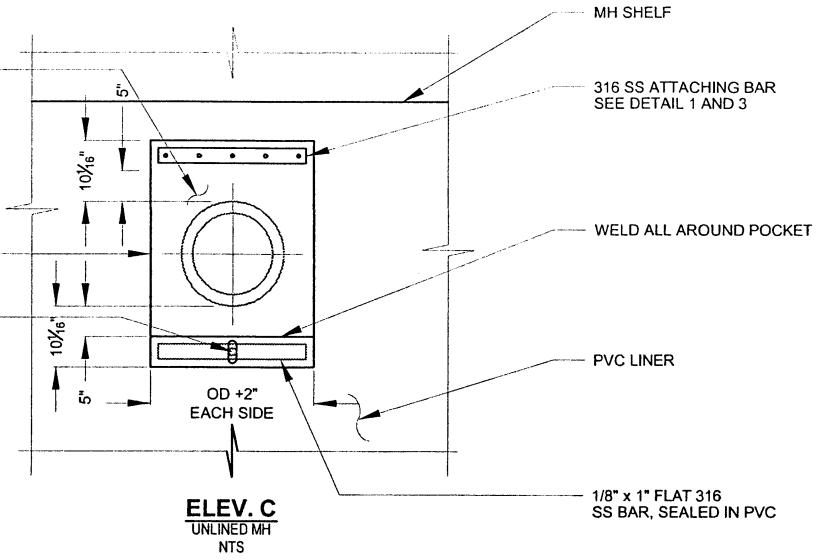

ELEV. C
UNLINED MH
NTS

NOTES:

1. FOR INSTALLATION AT EXISTING MH., SEE STD DWG. S-057
2. FOR MANHOLES WITHOUT PVC LINER, ATTACH GAS FLAP W/ 1/4" x 1" 316 SS FLAT BAR. DRILL HOLES 1/2" FROM EACH END AND ONE IN THE CENTER. (A = 3" OR LESS) SPACE OTHER HOLES 3" OR LESS
3. PROVIDE GAS FLAP FOR ALL LATERALS 12" AND LESS, UNLESS OTHERWISE SPECIFIED.

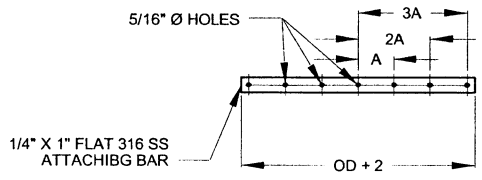

DETAIL 3
ATTACHING BAR SEE NOTE 2

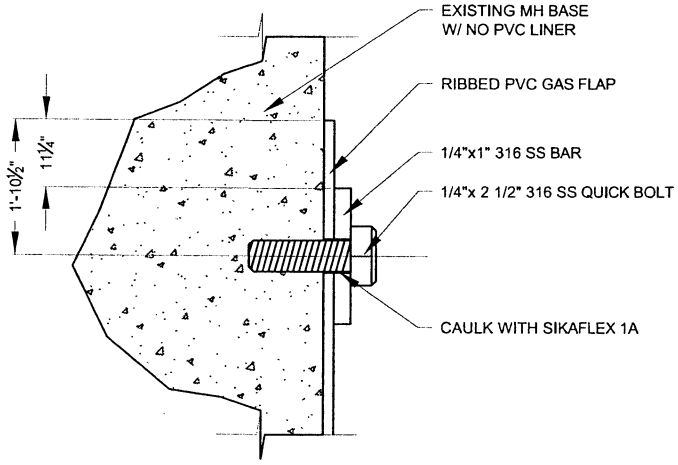

DETAIL 1
NTS

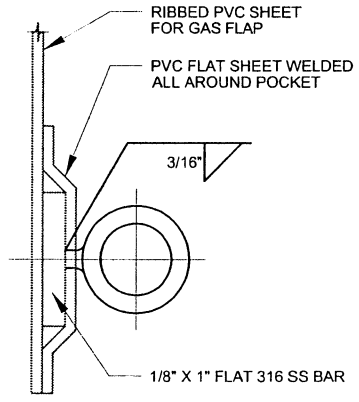

DETAIL 2
NTS

056

			ORANGE COUNTY SANITATION DISTRICT ORANGE COUNTY, CALIFORNIA	GAS FLAP INSTALLATION FOR UNPVC LINED OR UNLINED MANHOLES	3 OF 3
			APPROVED BY <i>[Signature]</i> DIRECTOR OF ENGINEERING		STANDARD DWG. S-056
NO.	APPROVED	DATE			
1	MST	2/07			

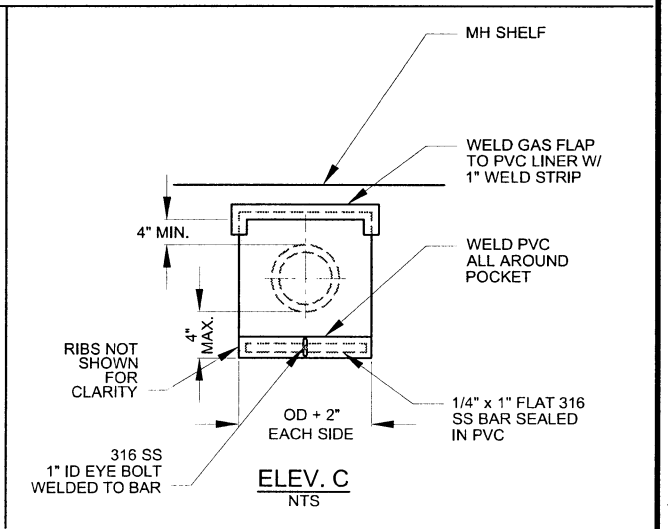
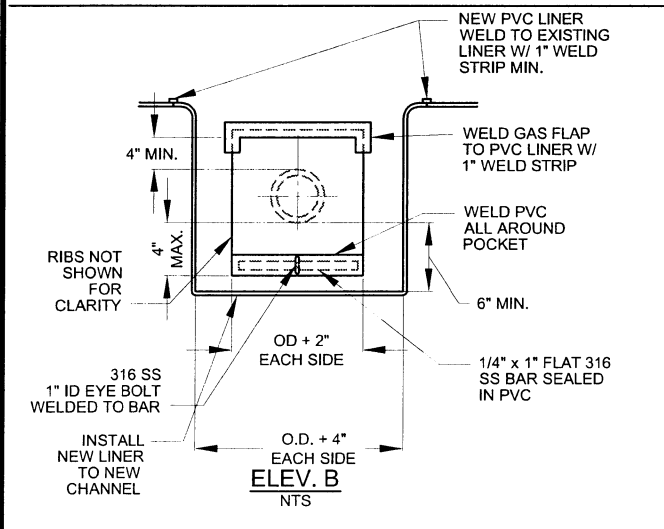
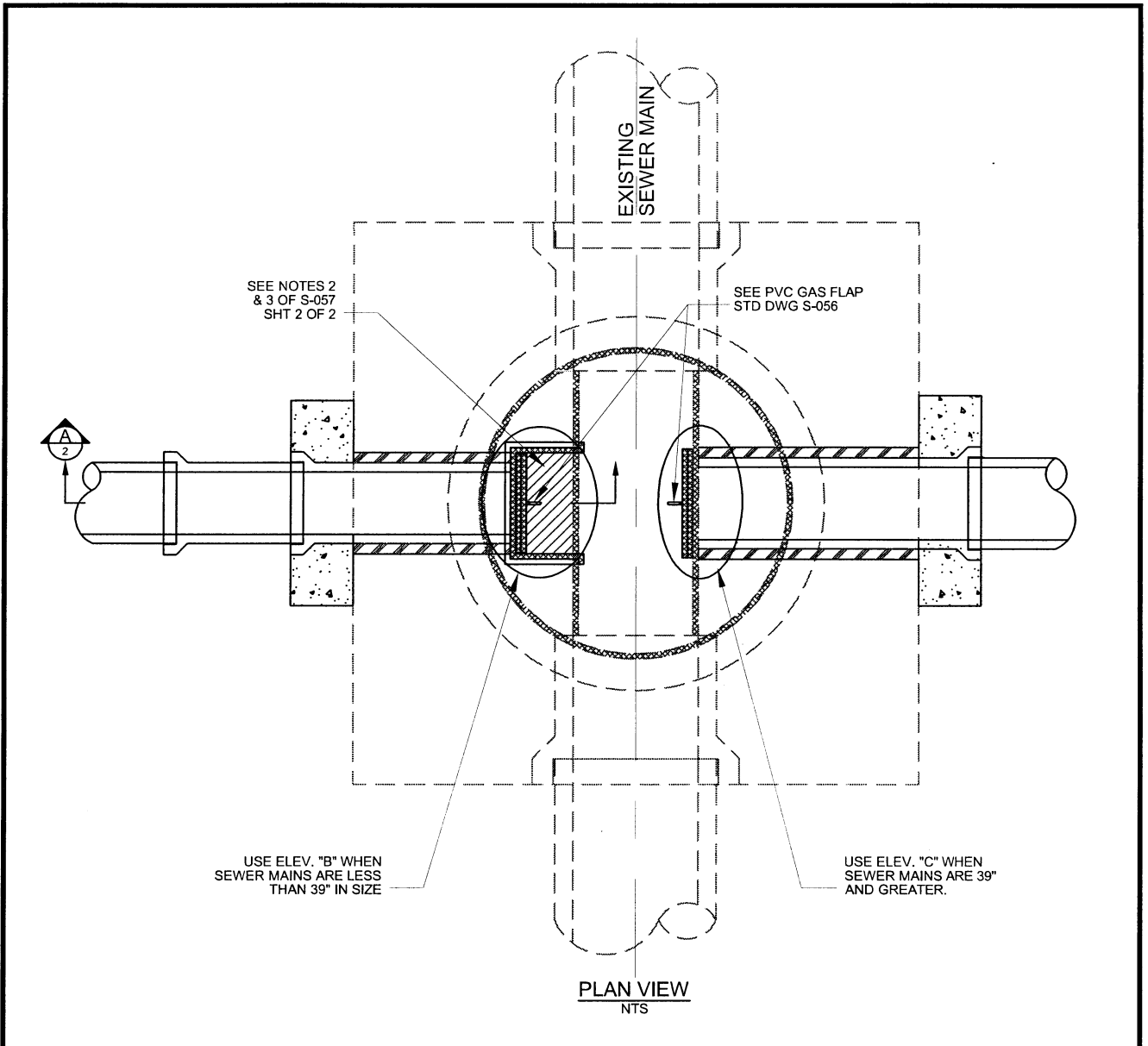

057

NO.	APPROVED	DATE
1	MST	2/07

ORANGE COUNTY SANITATION DISTRICT
ORANGE COUNTY, CALIFORNIA
APPROVED BY: *[Signature]* 02/20/07
DIRECTOR OF ENGINEERING DATE

CORE DRILLED STUB AT
EXISTING MANHOLE
DETAIL

1 OF 2
STANDARD DWG.
S-057

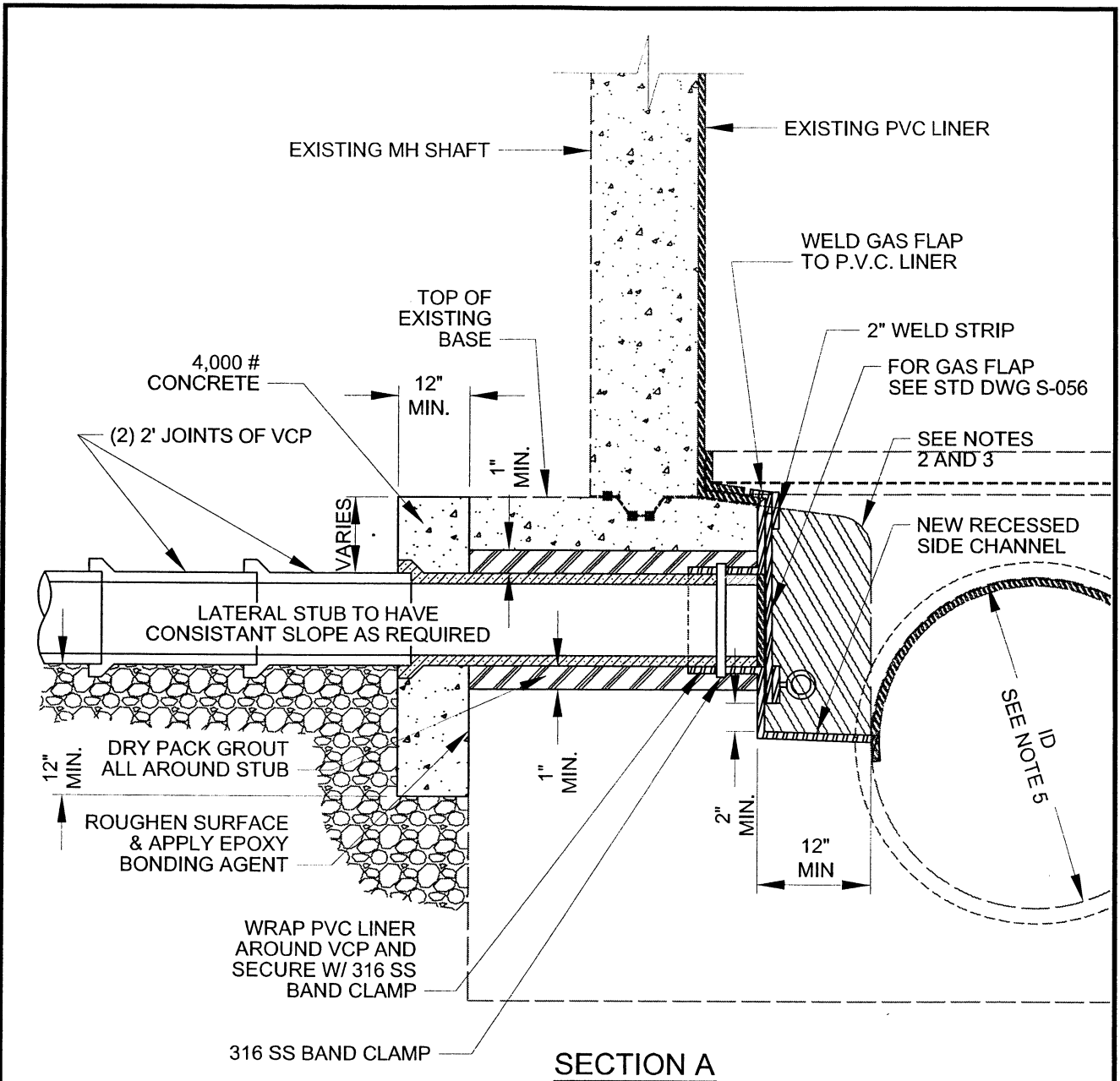

NOTE:

1. CORE DRILL EXISTING MH BASE A MIN. OF 2 INCHES LARGER THAN OUTSIDE DIAMETER (OD) OF NEW VCP STUB AND DRY PACK W/ CONCRETE GROUT AROUND OUTSIDE OF NEW VCP STUB AS SHOWN.
2. REMOVE EXISTING PVC LINER OVER EXISTING MH SHELF. JACK HAMMER OR REMOVE PORTIONS OF EXISTING CONCRETE BASE TO FORM NEW RECESSED CHANNEL A MIN. OF 2 INCHES IN WIDTH (ON EACH SIDE) BEYOND EDGE OF NEW GAS FLAP; OR FOR NEW VCP STUBS 15 INCHES OR GREATER IN DIAMETER, REMOVE A MIN. 4 INCHES IN WIDTH (ON EACH SIDE) GREATER THAN OD OF NEW VCP STUB. PATCH BOTTOM AND SIDES OF RECESSED CHANNEL W/ CONCRETE OR GROUT TO MAKE A SMOOTH TRANSITION ON SIDES AND BOTTOM OF CHANNEL.
3. INSTALL NEW MASTIC APPLIED AND MECHANICALLY ANCHORED PVC LINER IN RECESSED CHANNEL AREA OVER FRESHLY CURED CONCRETE AND IN ALL OTHER AREAS WHERE EXISTING PVC LINER WAS REMOVED. PVC WELD STRIPS SHALL BE USED TO PATCH ALL PVC JOINTS.
4. PROVIDE FLAT SHEET PVC GAS FLAP ON ALL LATERAL PIPES 12 INCHES IN DIA. AND LESS UNLESS OTHERWISE SPECIFIED. SEE STANDARD DRAWING S-056.
5. WHEN TRUNK LINE PIPE IS EQUAL TO OR GREATER THAN 39 INCHES IN DIAMETER, LATERAL PIPE SHALL EXTEND TO VERTICAL FACE OF MAIN CHANNEL WITHOUT HAVING A RECESSED SIDE CHANNEL.

057

			ORANGE COUNTY SANITATION DISTRICT ORANGE COUNTY, CALIFORNIA	CORE DRILLED STUB AT EXISTING MANHOLE DETAIL	2 OF 2
			APPROVED BY <i>Habay</i> 06/20/07 DIRECTOR OF ENGINEERING		STANDARD DWG. S-057
1	MST	2/07			
NO.	APPROVED	DATE			

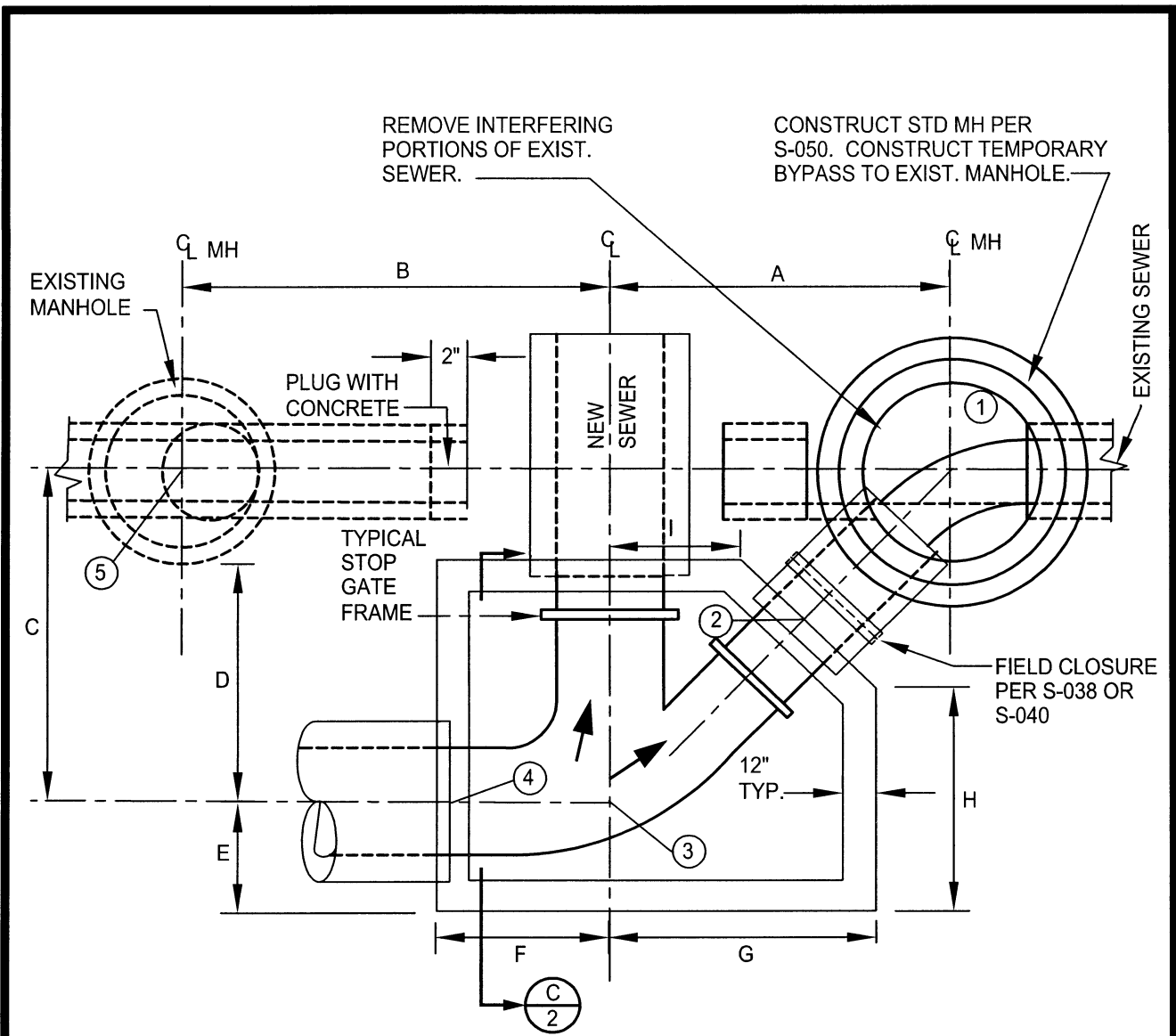

NOTES:

1. DIMENSIONS A,B,C,D,E,F,G,H, AND I SHALL BE AS SHOWN ON THE PLANS.
2. ELEVATIONS ① ② ③ ④ AND ⑤ SHALL BE AS SHOWN ON PLANS.
3. TYPICAL STOP GATE SHALL BE INCLUDED IN ALL DIVERSION STRUCTURE INSTALLATIONS.
4. FOR SECTIONS, SEE S-060 SHT. 2/2.

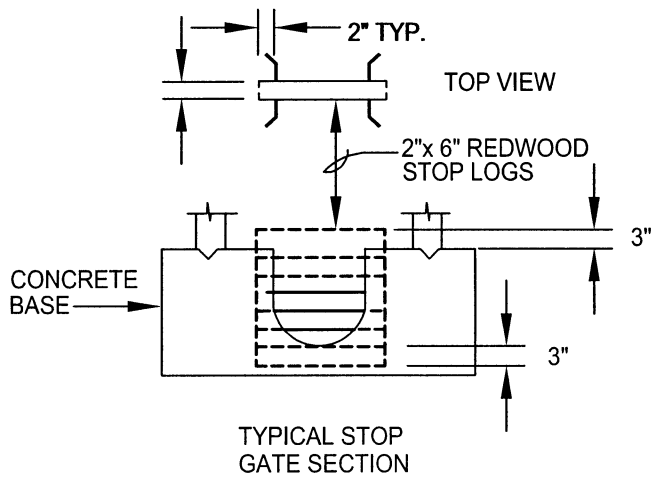

060.1

NO.	APPROVED	DATE

ORANGE COUNTY SANITATION DISTRICT
ORANGE COUNTY, CALIFORNIA
APPROVED BY: *[Signature]* 06/20/07
DIRECTOR OF ENGINEERING DATE

DIVERSION STRUCTURE
WITH STOP GATE
SHEET 1 OF 2

NO SCALE
STANDARD DWG.
S-060

WHEN D IS LESS THAN 12" USE FULL DEPTH AC PAVING OVER JUNCTION STRUCTURE

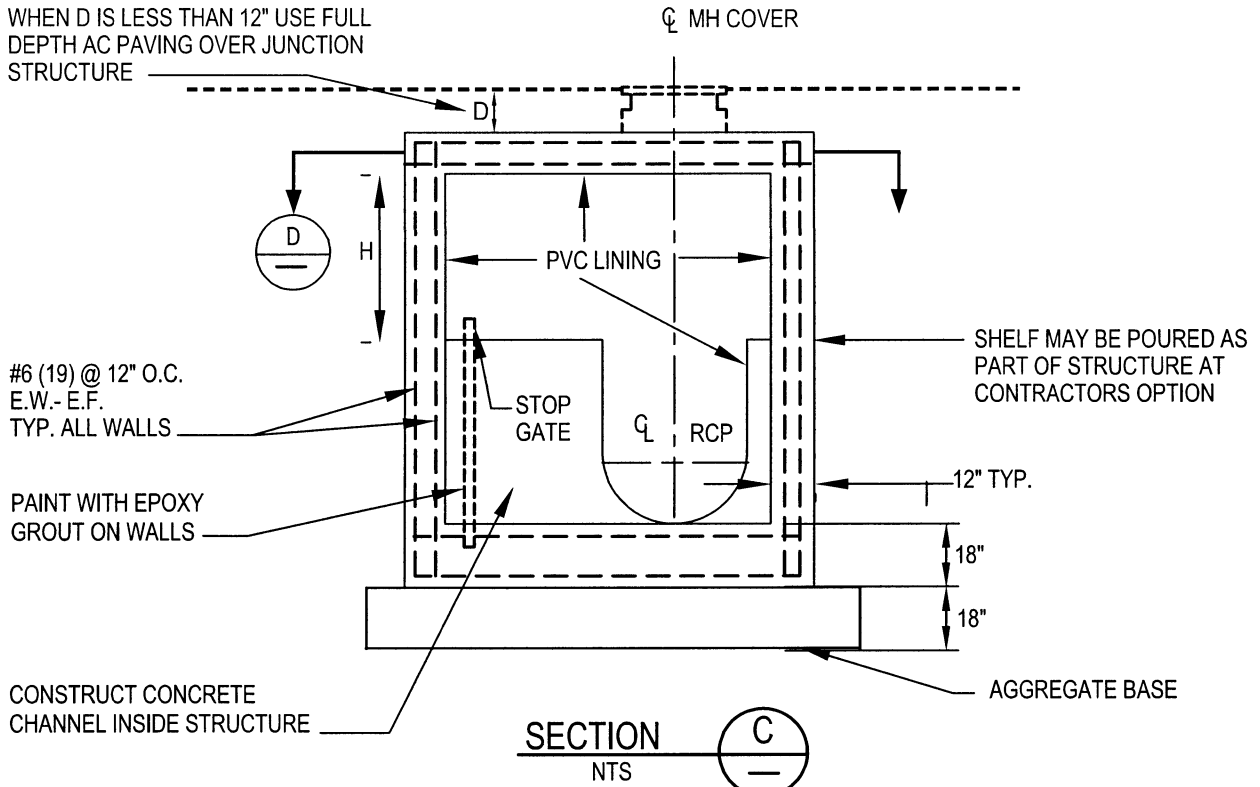

SECTION C
NTS

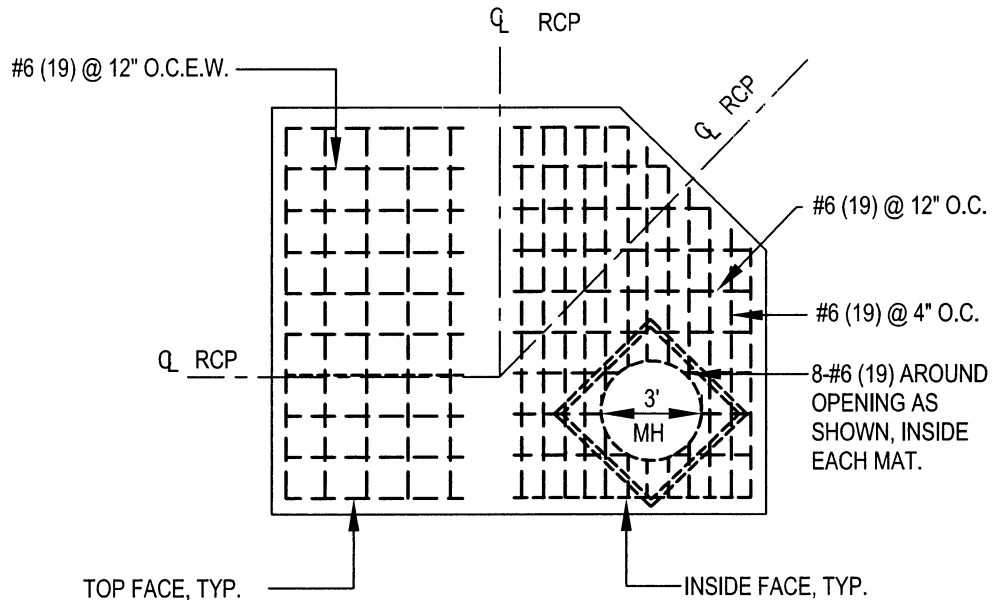

SECTION D
NTS

TOP SLAB ONLY

() DENOTES METRIC SYSTEM

NOTES:

1. ALL CONCRETE SHALL BE 4000 PSI (CLASS "A").
2. REINFORCING STEEL SHALL CONFORM TO ALL REQUIREMENTS OF THE STANDARD SPECIFICATIONS.
3. HEIGHT H SHALL NOT BE LESS THAN 7'-0" UNLESS OTHERWISE APPROVED BY THE ENGINEER.

060-2

NO.	APPROVED	DATE

ORANGE COUNTY SANITATION DISTRICT
ORANGE COUNTY, CALIFORNIA

APPROVED BY
A. Henry 06/20/07
DIRECTOR OF ENGINEERING

DIVERSION STRUCTURE
WITH STOP GATE
SHEET 2 OF 2

NO SCALE
STANDARD DWG.
S-060

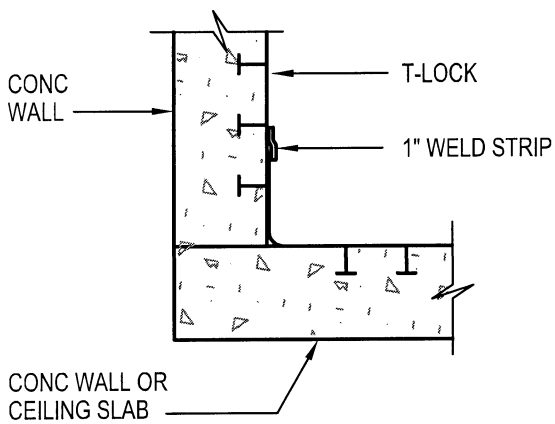

CORNER

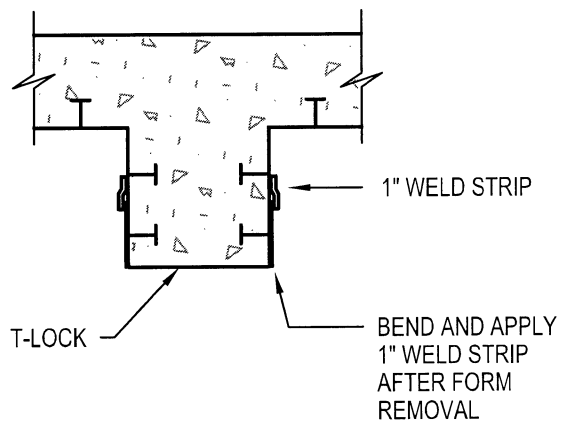

BEAM

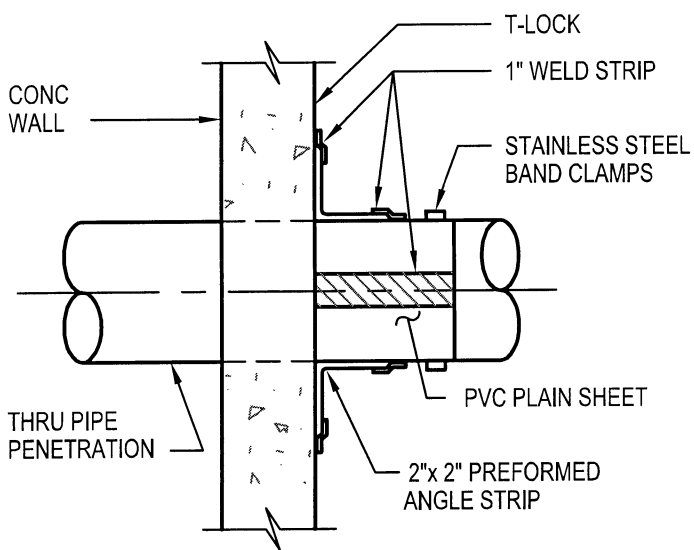

PIPE PENETRATION

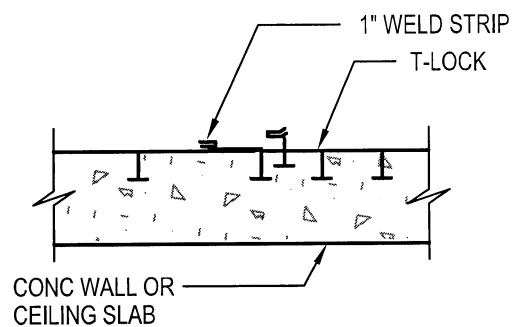

SPLICE

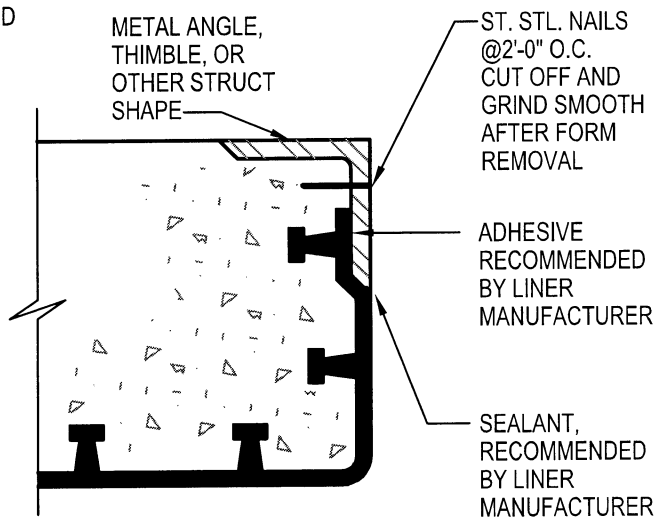

METAL EMBED

NOTES:

1. AT BUTT JOINTS, INSTALL 1" WELD STRIP ON FRONT AND BACK.
2. LINER RIBS SHALL BE ORIENTED VERTICALLY ON VERTICAL SURFACES.

065

NO.	APPROVED	DATE

ORANGE COUNTY SANITATION DISTRICT
ORANGE COUNTY, CALIFORNIA

APPROVED BY *Alabo* 6-21-07
DIRECTOR OF ENGINEERING DATE

LINER-PVC

NO SCALE
STANDARD DWG.
S-065

THE BELL ON THE COLLAR TEE SADDLE SHALL NOT BE ENCASED IN CONCRETE. TAP SHALL BE MADE AT THE APPROXIMATE CENTERLINE OF THE JOINT. ENCASE 12" EACH SIDE OF OPENING.

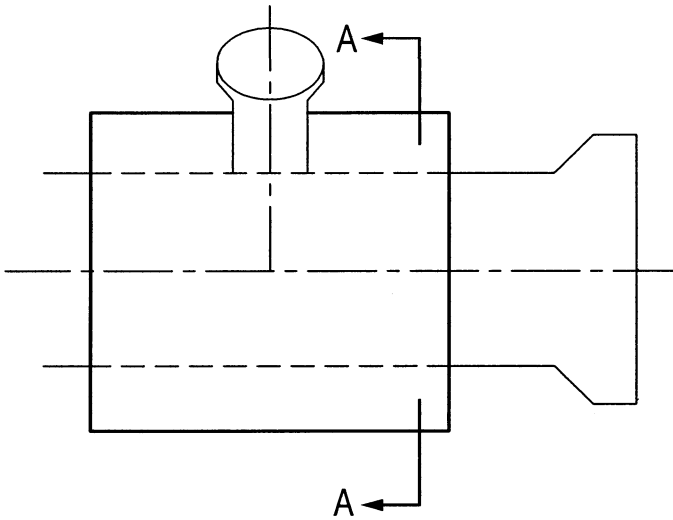

ELEVATION

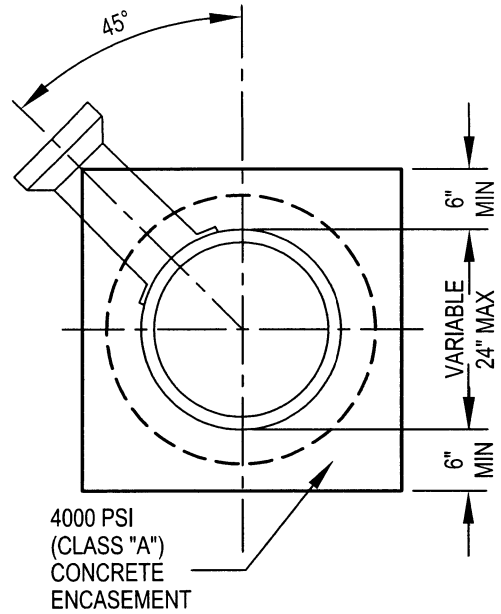

SECTION A-A

NOTE:

SADDLE CONNECTIONS SHALL NOT BE MADE TO SEWERS LARGER THAN 8" I.D. AND WILL BE ALLOWED ONLY IN ORANGE COUNTY SANITATION DISTRICT REVENUE AREA NO. 7.

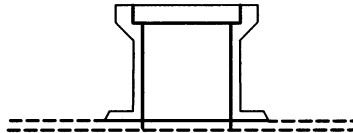

COLLAR TEE SADDLE

(AS PROVIDED BY MANUFACTURER)

NOTES:

1. THE CONTRACTOR SHALL SECURE THE COLLAR TEE SADDLE TO THE SEWER WITH AN EPOXY RESIN PROVIDED BY THE PIPE MANUFACTURER.
2. THE CONTRACTOR SHALL ENCASE THE SADDLE CONNECTION WITH 4000 PSI (CLASS "A") CONCRETE AFTER THE CONNECTION IS INSPECTED BY THE ENGINEER.
3. THE CONTRACTOR SHALL KEEP ALL CLAY CHIPS, DIRT, EPOXY, MORTAR AND CONCRETE OUT OF THE SEWER SADDLE, AND PERFORM A CLEANING AND BALLING OF THE SEWER.
4. THE CONTRACTOR SHALL REPAIR OR REPLACE ANY DAMAGED PIPE AS DIRECTED BY THE ENGINEER.
5. SADDLE CONNECTIONS TO SEWERS 8" IN DIAMETER SHALL BE DONE BY CORE DRILL.

NO.	APPROVED	DATE	ORANGE COUNTY SANITATION DISTRICT ORANGE COUNTY, CALIFORNIA	SADDLE CONNECTION, REVENUE AREA SEVEN ONLY	NO SCALE
			APPROVED BY <i>[Signature]</i> 06/20/07 DIRECTOR OF ENGINEERING		STANDARD DWG. S-070

070

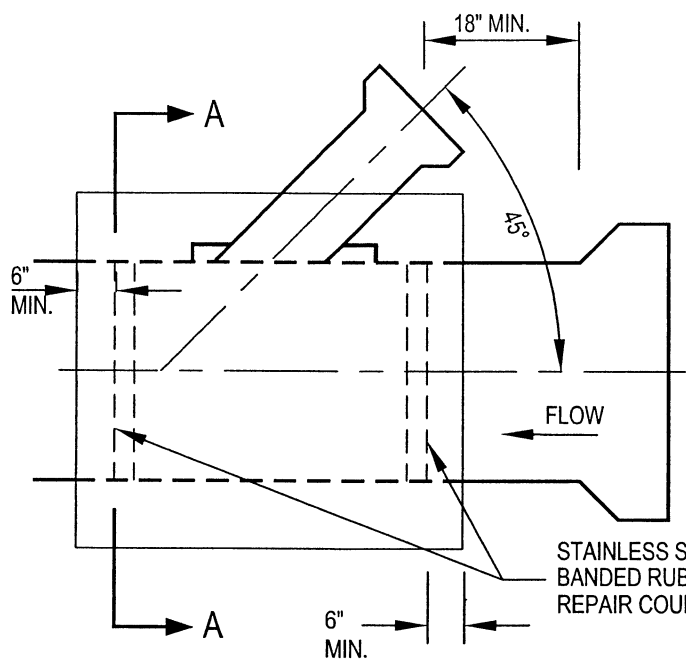

ELEVATION

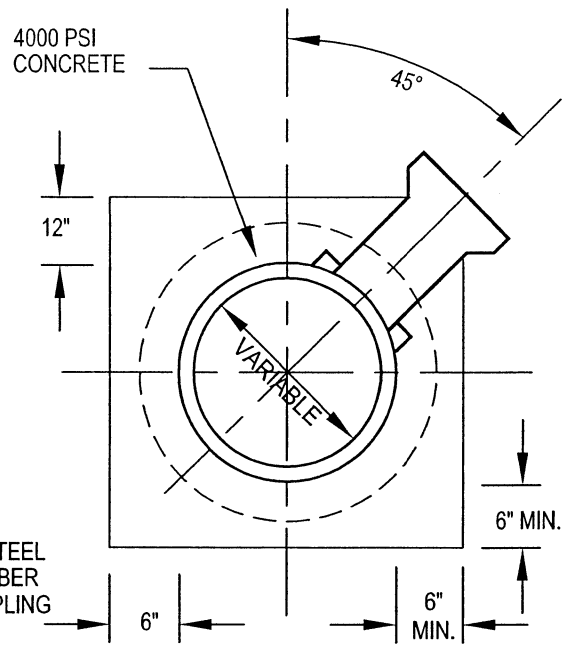

SECTION A-A

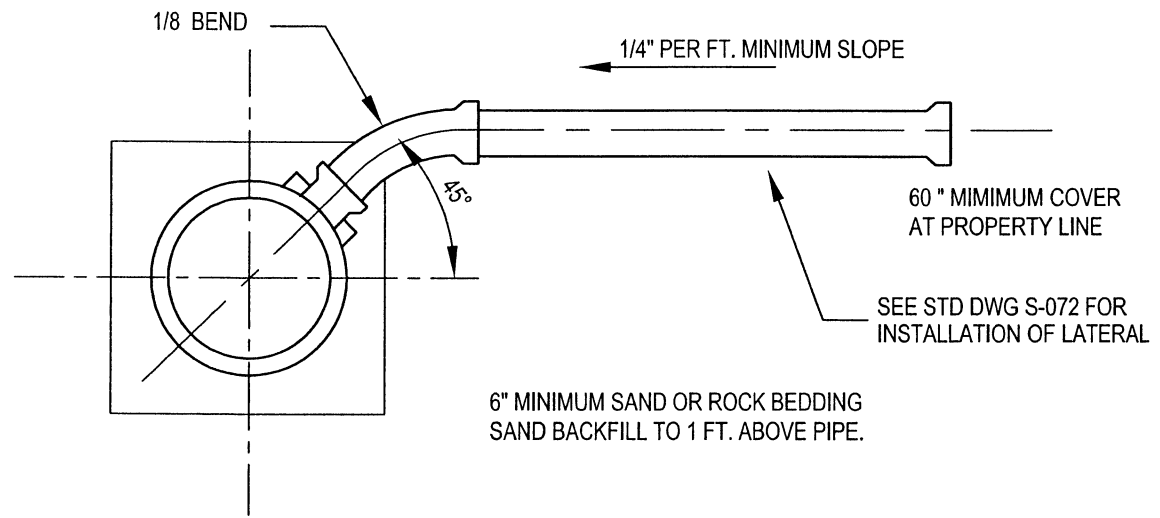

NOTES:

1. CONTRACTOR SHALL SECURE THE WYE COLLAR SADDLE CONNECTION TO THE SEWER PIPE BY CORE DRILLING FOLLOWED BY EPOXY RESIN ADHESIVE PROVIDED BY PIPE MANUFACTURER.
2. CONTRACTOR SHALL ENCASE THE SADDLE CONNECTION WITH 4000 PSI CONCRETE AFTER THE CONNECTION IS INSPECTED BY THE ENGINEER.
3. CONTRACTOR SHALL REPAIR OR REPLACE ANY DAMAGED PIPE AS DIRECTED BY ENGINEER.

			ORANGE COUNTY SANITATION DISTRICT ORANGE COUNTY, CALIFORNIA	CUT IN WYE CONNECTION UNINCORPORATED AREA ONLY	NO SCALE
			APPROVED BY <i>[Signature]</i> 06/20/07		STANDARD DWG.
071	1	CFW	6/06	DIRECTOR OF ENGINEERING	S-071
	NO.	APPROVED	DATE		

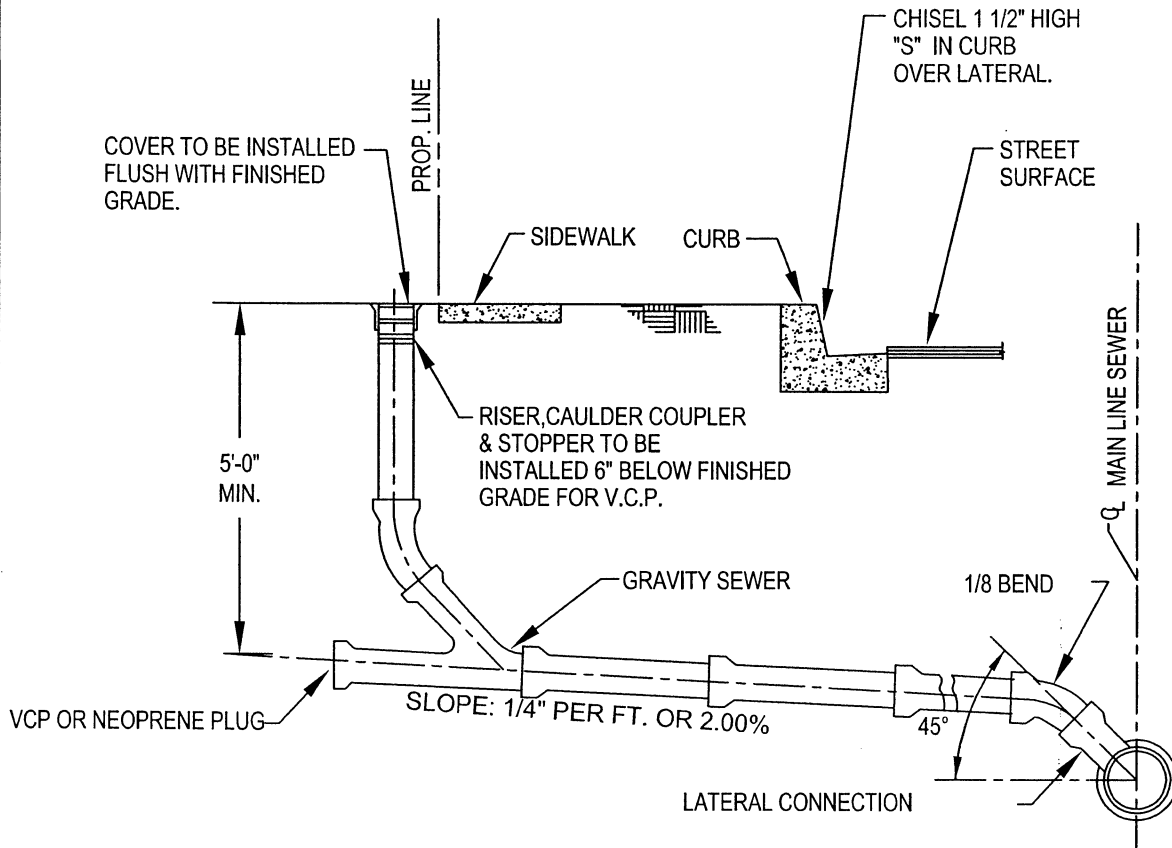

NOTES:

1. FOR SLOPE LESS THAN 1/4" PER FOOT, APPROVAL IS REQUIRED BY ENGINEER.
2. THE LATERAL SHALL BE BEDDED THE SAME AS THE MAINLINE SEWER.
3. FOR SEWER CLEANOUT RISER, USE PIPE OF THE SAME DIAMETER AND MATERIAL USED IN THE ADJOINING SEWER LINE.
4. SINGLE FAMILY RESIDENCES SHALL HAVE 4" DIAMETER VITRIFIED CLAY PIPE (VCP) SEWER LATERALS. ALL OTHERS SHALL BE 6" OR GREATER.
5. WHERE DIRECTED BY THE ENGINEER, THE CLEANOUT SHALL BE INSTALLED ON THE PUBLIC PROPERTY SIDE OF THE PROPERTY LINE WITHIN A 12" X 12" X 6" DEEP CONCRETE BOX.

072

			ORANGE COUNTY SANITATION DISTRICT ORANGE COUNTY, CALIFORNIA	HOUSE LATERAL CONNECTION, TYPICAL	NO SCALE
			APPROVED BY <i>James H. [Signature]</i> 06/20/07 DIRECTOR OF ENGINEERING		STANDARD DWG. S-072
1	CFW	6/06			
NO.	APPROVED	DATE			

LAMPHOLE COVER AND FRAME
FOR SEWER LINE INSPECTION AND EXAMINATION

PLATE NUMBER	CLEAR OPENING	OVERALL BASE	HEIGHT FRAME	APPROX. WEIGHT
M-1240	110 10	15	12	

PAINTED: BITUMINOUS PAINT

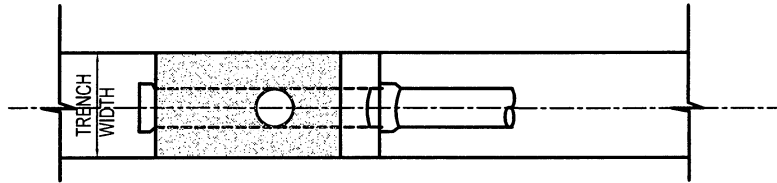
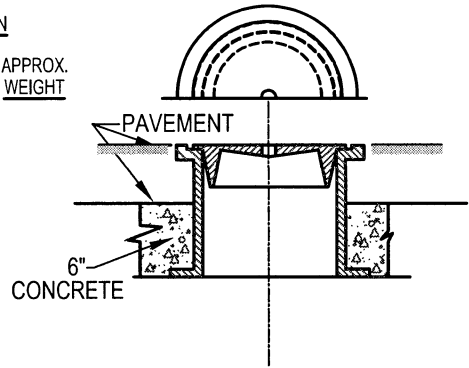

SECTION A-A

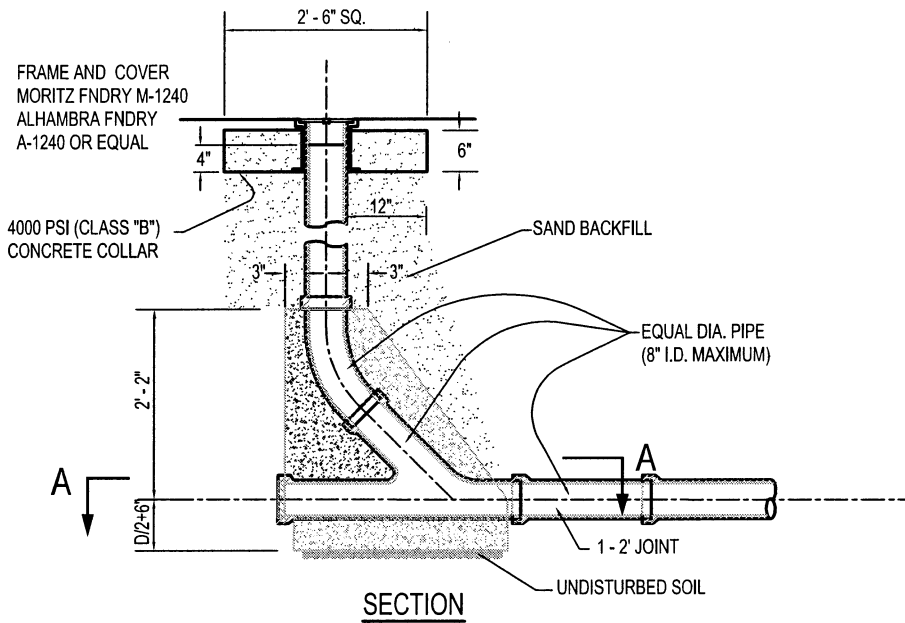

SECTION

NOTES:

1. CLEAN OUTS IN PUBLIC RIGHT OF WAY APPROVED FOR USE IN UNINCORPORATED AREAS ONLY. PERMISSION TO CONSTRUCT CLEAN OUTS MUST BE OBTAINED FROM THE ENGINEER IN EACH CASE.

073

			ORANGE COUNTY SANITATION DISTRICT ORANGE COUNTY, CALIFORNIA	CLEAN OUT DETAIL IN ROADWAY	NO SCALE
			APPROVED BY <i>[Signature]</i> 06/20/07		STANDARD DWG. S-073
NO.	APPROVED	DATE	DIRECTOR OF ENGINEERING	DATE	

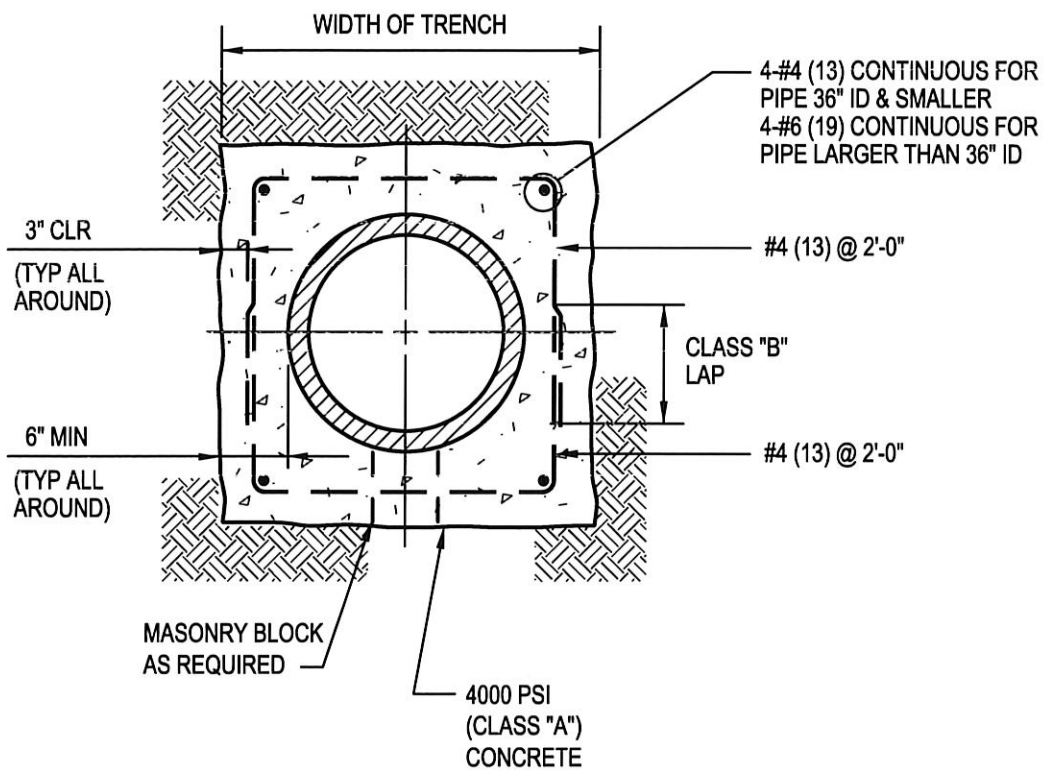

() DENOTES METRIC SYSTEM

			ORANGE COUNTY SANITATION DISTRICT ORANGE COUNTY, CALIFORNIA	CONCRETE ENCASEMENT OF PIPE	NO SCALE
			APPROVED BY <i>[Signature]</i> DIRECTOR OF ENGINEERING		STANDARD DWG. S-100
NO.	APPROVED	DATE	<i>[Signature]</i> 10/31/14	DATE	

100

This page intentionally left blank.