

**CITY OF LA HABRA  
PUBLIC WORKS DEPARTMENT  
ENGINEERING DIVISION**



110 E. LA HABRA BOULEVARD  
LA HABRA, CA 90631  
(562) 383-4151

**SPECIFICATIONS FOR  
ANNUAL ARTERIAL STREET REHABILITATION FY 19-20  
CITY PROJECT NO. 5-R-19**

CITY MANAGER		JIM SADRO
	<u>LA HABRA CITY COUNCIL</u>	
MAYOR		JOSE MEDRANO
MAYOR PRO TEM		JAMES GOMEZ
COUNCIL MEMBER		STEVE SIMONIAN
COUNCIL MEMBER		ROSE ESPINOZA
COUNCIL MEMBER		VACANT

BID OPENING: Wednesday, March 2, 2022 at 3:00 PM

PLANS AND SPECIFICATIONS:  
PICKED UP: \$20.00  
MAILED: \$25.00

**CITY OF LA HABRA  
PUBLIC WORKS DEPARTMENT  
ENGINEERING DIVISION**



110 E. LA HABRA BOULEVARD  
LA HABRA, CA 90631  
(562) 383-4151

**SPECIFICATIONS FOR  
ANNUAL ARTERIAL STREET REHABILITATION FY 19-20  
CITY PROJECT NO. 5-R-19**

**APPROVED BY:**

  
\_\_\_\_\_  
**ALBERT MENDOZA, P.E.  
DEPUTY DIRECTOR OF PUBLIC WORKS/CITY ENGINEER**

## TABLE OF CONTENTS

<u>NOTICE INVITING BIDS</u>	A-1
<u>INSTRUCTION TO BIDDERS</u>	B-1
<u>SPECIAL PROVISIONS</u>	C-1
SECTION 1. DEFINITION OF TERMS	C-2
SECTION 2. REQUIREMENTS AND CONDITIONS	C-3
SECTION 3. SCOPE OF WORK	C-7
SECTION 4. CONTROL OF THE WORK	C-8
SECTION 5. CONTROL OF MATERIAL	C-12
SECTION 6. LEGAL RELATIONS AND RESPONSIBILITIES	C-14
SECTION 7. PROSECUTION AND PROGRESS	C-22
SECTION 8. PAYMENTS	C-23
SECTION 9. WORK SCHEDULES	C-24
SECTION 10. CITY REQUIREMENTS	C-24
SECTION 11. CONSTRUCTION DETAILS	C-26
SECTION 12. BID ITEMS FOR ANNUAL ARTERIAL STREET REHABILITATION FY 19-20	C-35
<u>PROPOSAL</u>	D-1
PROPOSAL	D-2
BIDDER'S INFORMATION	D-5
EXHIBIT A, BID SCHEDULE 1	D-6
ACKNOWLEDGEMENT OF ADDENDA RECEIVED	D-9
REFERENCES	D-10
DBE BIDDER'S LIST	D-12
VIOLATIONS OF FEDERAL, STATE, OR LOCAL LAWS	D-13
DISQUALIFICATION OR DEBARMENT	D-14
LIST OF SUBCONTRACTORS	D-15
BID SECURITY FORM	D-16
BID BOND	D-17
NON-COLLUSION AFFIDAVIT	D-18
WORKER'S COMPENSATION CERTIFICATE	D-19
PUBLIC CONTRACT CODE SECTION 10285.1 STATEMENT	D-20
PUBLIC CONTRACT CODE SECTION 10162 QUESTIONNAIRE	D-21
PUBLIC CONTRACT CODE SECTION 10232 STATEMENT	D-22
<u>SAMPLE AGREEMENT</u>	E-1
ARTICLE I	E-2
ARTICLE II	E-2
ARTICLE III	E-3
ARTICLE IV	E-5
ARTICLE V	E-10
ARTICLE VI	E-12
FAITHFUL PERFORMANCE BOND	E-17
PAYMENT BOND	E-19
CERTIFICATION OF COMPLIANCE	E-21

APPENDIX "A", PROJECT LOCATION LIST  
APPENDIX "B", STANDARD PLANS  
APPENDIX "C", STREET CROSS SECTION DETAILS  
APPENDIX "D", SPEED LUMP DETAIL

**SECTION A**  
**NOTICE INVITING BIDS**

---

---

CITY OF LA HABRA

NOTICE INVITING BIDS

NOTICE IS HEREBY GIVEN that sealed bids will be received by the City Clerk of the City of La Habra, California for furnishing all labor, services, materials, tools, equipment, supplies, transportation, utilities and all other items and facilities necessary therefor as provided in the Contract Documents for the: **ANNUAL ARTERIAL STREET REHABILITATION FY 19-20, , CITY PROJECT NO. 5-R-19** in strict compliance with the specifications, plans and contract documents on file at the Office of the City Clerk of the City of La Habra.

DATE OF OPENING BIDS: Bids will be received at the Office of the City Clerk of the City of La Habra until **3:00 P.M. on Wednesday, March 2, 2022**, at which time and place the bids will be publicly opened and read aloud. Bids shall be submitted in sealed envelopes marked on the outside: **“ANNUAL ARTERIAL STREET REHABILITATION FY 19-20, CITY PROJECT NO. 5-R-19. DO NOT OPEN WITH REGULAR MAIL.”**

LOCATION OF WORK: The work to be constructed hereunder is shown attached as **APPENDIX “A”**

Typical work to be done is illustrated on the attached **APPENDIX “C”**

DESCRIPTION OF WORK: The work comprises the furnishing of all materials, equipment, tools, labor and incidentals as required by the Plans, Specifications and Contract Documents for the above stated project. The general items of work to be performed hereunder consist of but not be limited to **Mobilization/Demobilization; Traffic Control, Safety and Cleanup; Construction Staking and Monument Perpetuation; Storm Water Best Management Practices (BMPs); Crack Sealing; Unclassified Excavation and Disposal, Construct Rubberized AC pavement Overlay, Cold mill and Dispose of Existing Asphalt; Remove and Dispose of Existing Asphalt; Remove Existing and Construct Speed Lumps; Sawcut, Remove, and Construct Concrete Sidewalk; Sawcut, Remove, and Construct Concrete Curb and Gutter, Cross Gutters, Spandrels, and Driveways over CMB with AC Slot Trench; Sawcut and Remove Sidewalk and Ramp and Construct Curb Ramp with Detectable Warning Surface; Traffic Striping, Crosswalks, Curb Painting, Markings, and Raised Pavement Markers; Traffic Signal Loop Detectors; Adjust to Grade Water Valves, Manhole Covers; Traffic Signal Pull boxes, and Water Meter Boxes; Coordinate with Utilities for Adjust to Grade by Others; Grind Tree Roots; and all incidental work so indicated on the specifications, and required for the proposed improvements.**

CONTRACTOR’S LICENSE: The City of La Habra has determined that a Class **“A”** Contractor’s License is required for this project.

COMPLETION OF WORK: All work shall be completed within fifty (50) working days from the start date specified in the Notice To Proceed.

**AWARD OF CONTRACT:** The City of La Habra reserves the right, after opening the bids, to reject any or all bids, waive any informality or irregularity in such bids, or to award to the lowest responsible bidder and reject all other bids.

**PROPOSAL GUARANTEE AND BONDS:** Each bid must be accompanied by a certified cashier's check or by a corporate surety bond on the form furnished by the City of La Habra, as guarantee that the bidder will, if an award is made to him in accordance with the terms of his bid, promptly secure Worker's Compensation Insurance and Liability Insurance, execute the contract in the required form and furnish satisfactory bonds for the faithful performance of the contract and for the payment of claims of materialmen and workers thereunder. Said check or bidder's bond shall be in an amount of not less than ten percent (10%) of the amount of the bid. The Faithful Performance Bond shall be not less than one hundred percent (100%) of the total amount of the bid price named in the contract. The Payment Bond shall be not less than one hundred percent (100%) of the total amount of the bid price named in the contract. The City of La Habra reserves the right to reject any bond if, in the opinion of the Engineer, the Surety's acknowledgment is not in the form included in the contract documents or in another form substantially as prescribed by law.

**PREVAILING RATES OF WAGES:** Pursuant to the provisions of Section 1773 of the Labor Code of the State of California, the Director of Industrial Relations has ascertained the general prevailing rate of wages and employer payments for health and welfare, vacation, pension and similar purposes applicable to the work to be done. A copy of said wage rates is available on-line at:

<https://www.dir.ca.gov/dlsr/DPreWageDetermination.htm>

The Contractor and all subcontractors are responsible to pay the prevailing rates of wages that are specified within ten (10) calendar days before the bid open day and shall post a copy of said wage rates at the project site. The statutory provisions for penalties for failure to pay prevailing wages will be enforced (Labor Code §1775) and the statutory provisions for failure to comply with the States' wage and hour laws will be enforced (Labor Code §1813).

**DEBARMENT:** No Contractor or Subcontractor may be awarded as a contractor on a bid proposal if they have been Debarred by the State pursuant to Labor Code Sections 1777.1 and 1777.7 and Public Contracts Code Section 6109.

**APPRENTICE:** The Contractor shall comply with all laws, rules, regulations, and all the requirements of the Labor Code including, but not limited to, Section 1776, 1777.5, and 1777.6 of the California Labor Code.

**CONTRACT DOCUMENTS:** The Contract Documents shall consist of the following: Notice Inviting Bids; Instructions to Bidders; Proposal; Bidder's Information; Bid Schedule; Acknowledgement of Addenda Received; References; DBE Bidder's List; Violations of Federal, State, or Local Laws; Disqualification or Debarment; List of Subcontractors; Bid Security Form; Bid Bond; Non-Collusion Affidavit; Worker's Compensation Certificate; Public Contract Code Section 10285.1 Statement; Public Contract Code Section 10162 Questionnaire; Public Contract

Code Section 10232 Statement; Agreement; Faithful Performance Bond; Payment Bond; Certification of Compliance; Special Provisions; Drawings; and the Standard Specifications for Public Works Construction, latest edition and supplements thereto, made a part by reference, together with all additions, deletions, modifications or interpretations of any of said documents, all of which are hereby made a part of this Notice Inviting Bids.

Specifications are available for inspection, without charge, at the Office of the City Engineer of the City of La Habra.

Complete sets of said plans, specifications, and bid documents may be purchased at twenty dollars (\$20.00) per set and are obtainable from the City Engineer of the City of La Habra, 110 E. La Habra Blvd, La Habra, California. An additional five dollars (\$5.00) shall be charged for requests by mail. No refund shall be made for sets of said plans, specifications, and bid documents returned.

**ADDRESS AND MARKING OF PROPOSAL:** The envelope enclosing the proposal shall be sealed and addressed to the City Clerk and hand delivered to the City Clerk at the Civic Center, 110 E. La Habra Blvd (Administration Department), or mailed to City Clerk, Civic Center, 110 E. La Habra Blvd, La Habra, California 90631. The envelope shall be plainly marked in the upper left-hand corner with the name and address of the bidder and shall bear the words "Proposal For" followed by the title of the specifications for the work, and the date and hour of opening bids. The certified or cashier's check, money order, or bidder's bond shall be enclosed in the same envelope with the proposal.

**DEPARTMENT OF INDUSTRIAL RELATIONS (DIR) REQUIREMENT:** No Contractor or Subcontractor may be listed on a bid proposal for a public works project unless registered with the Department of Industrial Relations (DIR) pursuant to Labor Code 1725.5 and Senate Bill 854. Payroll documents for the contractor and subcontractors should be submitted and registered on time with the DIR.

**Under California Labor Code Section 1771.1, in order to be awarded and to perform work on public works projects, prime contractors and subcontractors must possess and maintain registration with the Department of Industrial Relations (DIR) at <https://www.dir.ca.gov/public-works/contractor-registration.html>. This is a separate requirement from the Contractors State License Board (CSLB) licensing requirement. See the Special Provisions for additional details.**

**SUBMISSION OF QUESTIONS:**

- Questions received after Wednesday, February 17, 3:00 pm may not be considered.
- Questions or clarifications deemed by the City to be material change will be answered via issuance of an addendum and posted to the City's online bidding service, CIPlist.com.
- Only questions answered by formal written addenda shall be binding. Oral and other interpretations or clarifications shall be without legal effect. It is the Bidder's responsibility to be informed of any issued addenda and to include all such information in its Bid.
- Any questions regarding this solicitation shall be submitted electronically to Kahono Oei at [koei@lahabraca.gov](mailto:koei@lahabraca.gov) or [jvaldez@lahabraca.gov](mailto:jvaldez@lahabraca.gov)

**BID SCHEDULE:**

Bid Advertisement .....Monday, February 7, 2022  
Requests for Information .....due by Tuesday February 17, 3:00 pm  
Response to Requested for Information.....Thursday February 23, 3:00 pm  
Bid Opening .....due by Wednesday, March 2, 2022, 3:00 pm

**SECTION B**  
**INSTRUCTIONS TO BIDDERS**

CITY OF LA HABRA

INSTRUCTIONS TO BIDDERS

The following instructions and conditions apply to the attached bid and the bidder acknowledges the acceptance thereof by signing and filing said bid.

Each bidder shall state whether he is an individual, firm or corporation; if firm, give name of each member; if a corporation, give name of president, secretary, treasurer and manager.

Proposals shall be submitted to the City of La Habra on forms prepared and furnished in the bid documents, or as provided by the Engineering Office of the City of La Habra. When presented, they must be completely made out in the manner and form indicated therein, showing the proposed prices clearly and legibly and must be properly signed by the bidder. Proposals presented otherwise may be rejected.

Each proposal so submitted, together with the required proposal guarantee hereinafter prescribed, shall be presented under sealed cover and must be filed prior to the time and place designated in the Notice Inviting Bids. A proposal so presented, however, may be withdrawn by the bidder provided the request therefor is made in writing, is signed by the bidder or his authorized representative and is filed prior to the time fixed for the opening of bids. The withdrawal of a bid proposal does not prejudice the right of the bidder to file a new bid.

All proposals submitted as hereinabove prescribed will be publicly opened and read at the time and place indicated in the Notice Inviting Bids.

Bids are required for the entire work. The amount of the bid for comparison purposes will be the total of all items.

The bidder shall set forth for each item of work, in words and in clearly legible figures, a unit price and an amount for the item in the respective space provided for this purpose. In the case of unit price items, the amount set forth under the "AMOUNT" column shall be the extension of the unit price bid on the basis of the estimated quantity for the item. In case of discrepancy between the words and figures, the words shall prevail.

In case of discrepancy between the "Unit Price" and the "Amount" set forth for the item, the Unit Price shall prevail. However, if the amount set forth as a Unit Price is ambiguous, unintelligible or uncertain for any cause or is omitted or in the case where the Unit Price is the same amount as the entry in the "AMOUNT" column for the item, the "AMOUNT" price shall prevail in accordance with the following:

- (1) As to lump sum items, the amount set forth in the "AMOUNT" column shall be the unit price.
- (2) As to unit price items, the amount set forth in the "AMOUNT" column shall be divided by the estimated quantity for the item and the price thus obtained shall be the unit price.

In case of discrepancy between the sum of the individual "AMOUNT" prices, and the Total Bid Price, the sum of the individual "AMOUNT" prices will prevail.

Bidders must satisfy themselves by personal examination of the location of the proposed work and by personal examination of the proposed contract documents as to the actual conditions and the requirements of this work and shall not at any time after submission of the bid dispute, complain or assert that there was any misunderstanding in regard to the nature or the amount of work to be done unless a written change in these specifications or contract or written clarification thereof has been issued by the City of La Habra.

Each bid must be in a sealed envelope which is to be clearly marked so as to identify it as a bid (such as "Sealed Bid - do not open with regular mail"), giving the number and name of the project or specification and the name of the bidder. These instructions are particularly necessary if your bid is transmitted by mail. Failure to identify the project or to address it to the City Clerk, Civic Center, 110 E. La Habra Blvd, La Habra, California 90631, Attention City Clerk, will result in the opening of the envelopes with the regular mail and may thereby void the bid.

The City Council will award the contract to the lowest responsible bidder, however, said Council reserves the right to reject any or all bids, to waive any informality in the bids received and, if necessary, to take said bids under advisement for a period not to exceed sixty (60) days including lead-time.

All proposal requirements and conditions as set forth in the Standard Specifications shall apply hereto.

APPROXIMATE ESTIMATE: The quantities shown in the proposal form and in the estimate included in the bid documents shall be considered as approximate only, being listed therein for the purpose of serving as a general indication of the amount of work or materials to be performed or furnished as a basis for the comparison of bids. The Council does not guarantee nor agree, either expressly or by implication, that the actual amounts required will correspond therewith, but reserves the right to increase or decrease the amount of any item, portion of work to be performed or material to be furnished, or to omit any such item or portion, in accordance with the provisions relative thereto set forth in the bid documents or Standard Specifications under which the work is to be constructed, without in any way invalidating the contract should such increase, decrease or omission be deemed necessary or expedient. The City of La Habra reserves the right to increase or decrease the amount of any item as necessary due to budgetary requirements.

DISADVANTAGED BUSINESS ENTERPRISE (DBE) REQUIREMENTS: The City of La Habra requires that Disadvantaged Business Enterprises (DBEs) have the opportunity to participate in public works projects. To assist the City of La Habra in establishing future Annual Anticipated DBE Participation Level (AADPL), all contractors are required to submit a list of all subcontractors and suppliers, whether DBE or not, contacted during preparation of the bid.

**SECTION C**

**SPECIAL PROVISIONS**

## SPECIAL PROVISIONS

### SECTION 1. DEFINITION OF TERMS

CITY: The City of La Habra

CITY COUNCIL: The City Council of the City of La Habra.

ENGINEER: Any reference to the "Engineer" in the specifications shall be construed to mean the City Engineer of the City of La Habra or his authorized agents.

BIDDER: Any individual, firm or corporation submitting a bid to furnish the materials and equipment and perform the work herein specified, properly made out on the form furnished by the City Engineer, duly executed by the bidder and enclosed within a sealed envelope directed to the City Clerk, Civic Center, 110 E. La Habra Blvd., La Habra, California 90631.

BID FORMS: The blank forms prepared by the City of La Habra on which the bidder must submit the bid.

CONTRACTOR: The bidder whose bid is accepted and to whom the contract is awarded.

CONTRACT: The Specifications, Special Provisions, the notice inviting bids, the bid and addenda of the Contract, and the agreement entered into pursuant thereto shall constitute the Contract between the City of La Habra and the Contractor.

LABORATORY: The designated laboratory authorized by the Engineer to test materials and work involved in the contract.

THE WORK: All the work required to be performed under the contract.

GENERAL CONSTRUCTION TERMS: Unless otherwise specifically defined herein or unless the content requires a different meaning, all words, terms and phrases having a well-known or technical meaning shall be so construed.

USE OF PRONOUNS: Words used herein in the masculine gender include the feminine and neuter and vice versa; the singular number includes the plural and the plural the singular. The word "person" includes a corporation, association or partnership.

SECTION: The part into which these Special Provisions are divided. Each section is designated by a whole number preceding its title.

ARTICLES: The parts into which sections are divided. Each article is designated by a number preceding its title, the first two figures to the right of the decimal point being the number of the article and the figures or figure to the left of the decimal point being the number of the section of which such article is a part. Thus: Article 11.05 indicates Article 5 of Section 11.

SUBDIVISIONS: The parts into which articles are divided. Each subdivision is designated by a number preceding its title, the figure or figures to the right of the article number being the number of the subdivision. Thus: Subdivision 11.05.2 indicates Subdivision 2 of Article 5 of Section 11.

STANDARD SPECIFICATIONS: The document entitled "Standard Specifications for Public Works Construction", latest edition and supplements thereto, are hereinafter referred to as the Standard Specifications.

Other terms appearing in the Standard Specifications shall have the intent and meaning specified in Section 1 "General" of the Standard Specifications.

In case of conflict between the Standard Specifications and these Special Provisions, these Special Provisions shall take precedence over and be used in lieu of such conflicting portions of the Standard Specifications.

## SECTION 2. REQUIREMENTS AND CONDITIONS

ARTICLE 2.01: EXAMINATION OF PLANS, SPECIFICATIONS, SPECIAL PROVISIONS, AND WORKSITE: Bidders must satisfy themselves by personal examination of the proposed work site and by such other means as they may prefer as to the actual conditions and requirements of the work. Bidders shall not at any time after submission of the bid, dispute, complain or assert that there was any misunderstanding in regard to the nature or amount of work to be done.

The CITY, in accordance with Title VI of the Civil Rights Act of 1964 (78 Stat 252) and the Regulations of the Department of Commerce (15 C.F.C., Part 8), issued pursuant to such Act, hereby notifies all bidders that it will affirmatively insure that the contract entered into pursuant to this advertisement will be awarded to the lowest responsible bidder without discrimination of the grounds of race, color or national origin.

ARTICLE 2.02 BID FORMS: All bids submitted shall be made on the blank forms provided with the bid documents. Bids submitted on forms other than those provided with the bid documents shall be rejected. All bids shall give the price bid both in writing and figures and shall be signed by the bidder with his address. Bids shall be enclosed in a sealed envelope directed to the City Clerk, Civic Center, 110 E. La Habra Blvd, La Habra, California 90631.

ARTICLE 2.03 IRREGULAR BIDS: Bids may be rejected if they show any alterations of form, additions not called for, conditional bids, incomplete bids, erasures or irregularities of any kind.

ARTICLE 2.04 DISQUALIFICATION OF BIDDERS: The CITY COUNCIL may reject any and all bids should it deem this for the public good and the bid of any party who has been delinquent or unfaithful in any former contract with the CITY, and may reject all bids other than the lowest bid of any responsible bidder and may award the contract for said work or improvement to the lowest responsible bidder at the prices named in his bid.

ARTICLE 2.05 MATERIAL GUARANTEE: Before any bid is accepted, the bidder may be required to furnish a complete statement of the origin, composition and manufacture of any or all

materials to be used in the construction of the work, together with samples which may be subjected to the tests provided for in these Specifications or in the Special Provisions to determine their quality and fitness for the work.

ARTICLE 2.06 BONDS: In lieu of Section 1-7.2 "Contract Bonds" of the Standard Specifications, the Contractor, simultaneously with the execution of the Agreement, shall furnish a surety bond in an amount equal to one hundred (100) percent of the contract price as security for the faithful performance of the contract and a separate surety bond in an amount equal to one hundred (100) percent of the contract price as security for the payment of all persons performing labor and furnishing materials in connection with the contract. Said bonds shall be secured from a Surety Company satisfactory to the CITY.

ARTICLE 2.07 BID GUARANTEE:

Subdivision 2.07.1: All bids shall be presented under sealed cover and shall be accompanied by cash, cashier's check, certified check or bidder's bond made payable to the City of La Habra for an amount equal to at least ten percent (10%) of the amount of said bid. No bid will be considered unless such cash, cashier's check, certified check or bidder's bond is enclosed therewith.

Subdivision 2.07.2: Return of Bid Guarantee: The bid guarantee of the bidder or bidders who are being considered for the award of Contract shall be held until the execution of said contract, and shall thereupon be returned to the bidder. Bid guarantee of other bidders will be returned to such bidders upon award of the Contract.

ARTICLE 2.08 AWARD OF CONTRACT: The award of contract, if it be awarded, will be within sixty (60) days of the opening of bids.

ARTICLE 2.09 EXECUTION OF CONTRACT: The contract, construction schedule, and bonds shall be executed and filed by the successful bidder with the City Clerk of the City of La Habra not later than ten (10) days after the award of contract.

All bidders may submit with their bids a sworn statement of their financial responsibility, technical ability and experience. Such sworn statement may be required to be furnished before award is made to any particular bidder.

The CITY COUNCIL may, upon the refusal or failure of successful lowest responsible bidder to accept the contract, award it to the second lowest responsible bidder. If the legislative body awards the contract to the second lowest bidder, the amount of the lowest bidder's security shall be applied by the CITY to the difference between the low bid and the second lowest bid; and the surplus, if any, shall be returned to the lowest bidder if cash or a check is used, or to the surety company if bidder's bond is used.

ARTICLE 2.10 BEGINNING OF WORK: The Contractor shall begin work from the start date specified in the Notice To Proceed.

**ARTICLE 2.11 PLANS AND SPECIFICATIONS:** Specifications and bid documents are on file at the Office of the City Engineer, Civic Center, 110 E. La Habra Blvd., La Habra, California. Copies may be purchased from the City Engineer for a fee of twenty dollars (\$20.00) for each set of specifications and accompanying drawings. An additional fee of five dollars (\$5.00) shall be charged for requests made by mail. No refunds shall be made for sets of said plans, specifications and bid documents returned. A digital copy of said Contract Documents (saved in PDF format) are available free of charge posted at the following website:

<http://www.ciplist.com/>

**ARTICLE 2.12 CONTRACT DOCUMENTS:** The Contract Documents shall consist of the following: Notice Inviting Bids; Instructions to Bidders; Proposal; Bidder's Information; Bid Schedule; Acknowledgement of Addenda Received; References; DBE Bidder's List; Violations of Federal, State, or Local Laws; Disqualification or Debarment; List of Subcontractors; Bid Security Form; Bid Bond; Non-Collusion Affidavit; Worker's Compensation Certificate; Public Contract Code Section 10285.1 Statement; Public Contract Code Section 10162 Questionnaire; Public Contract Code Section 10232 Statement; Agreement; Faithful Performance Bond; Payment Bond; Certification of Compliance; Special Provisions; Drawings; and the Standard Specifications for Public Works Construction, latest edition and supplements thereto, together with all additions, deletions, modifications, appendices and all addenda as prepared prior to the date of the bid opening setting forth any modifications or interpretations of any said documents are hereby incorporated in and made a part of the Contract Documents.

All Contract Documents are complementary, and what is called for in any one shall be as binding as if called for in all. The intention of the documents is to require a complete and finished piece of work. The Contractor, at his sole cost and expense, shall perform all labor and services and shall furnish all materials, tools, equipment and facilities necessary for the proper execution of the work, with the exception of such items as may be definitely stipulated in the Specifications or on the Plans to be furnished by the CITY. Anything shown on the Plans and not in the Specifications, or in the Specifications and not in the Plans, shall be performed by the Contractor as though shown on both the Plans and Specifications.

Documents which shall be signed and returned to the CITY with Bid Proposal are:

Proposal; Bidder's Information; Bid Schedule; Acknowledgement of Addenda Received; References; DBE Bidder's List; Violations of Federal, State or Local Laws; Disqualification or Debarment; List of Subcontractors; Bid Security Form; Bid Bond; Non-Collusion Affidavit(s) (Principal and Subcontractor); Worker's Compensation Certificate; Public Contract Code Section 10285.1 Statement; Public Contract Code Section 10162 Questionnaire; and Public Contract Code Section 10232 Statement.

Documents which are to be signed and returned to the CITY by the winning bidder are:

Agreement; Faithful Performance Bond; Payment Bond; Certification of Compliance; Liability Insurance; and Workers Compensation Insurance.

Subdivision 2.12.1 Precedence Of Contract Documents: If there is a conflict between Contract Documents, the order of precedence shall be as follows:

1. Contract
2. Specifications
3. Plans

Within the Specifications, the order of precedence is as follows:

1. Change Orders
2. Addenda
3. Permits from other agencies/Supplemental Agreements
4. Special Provisions
5. Instructions to Bidders
6. Notice Inviting Bids
7. Referenced Standard Drawings
8. Referenced Standard Specifications

With reference to Plans, the order of precedence is as follows:

1. Change Order drawings govern over Addenda and Contract drawings.
2. Addenda drawings govern over contract drawings.
3. Contract drawings govern over shop drawings and Standard drawings.
4. Detail drawings govern over general drawings.
5. Figures govern over scaled dimensions.

ARTICLE 2.13 AUTHORITY OF THE ENGINEER: The Engineer shall have the authority to direct as may be necessary to ensure that the work is in strict compliance with the Contract Documents; determine the quantity, quality and soundness of the work; determine if material and equipment being used is satisfactory; interpret the requirements of the contract; and, make decisions regarding the progress and execution of the work. However, neither the Engineer nor any representative of the Engineer shall have the authority to authorize extra work without prior approval by the CITY COUNCIL. Should any discrepancy appear or any misunderstanding arise as to the importance of anything contained in the Specifications or Plans, the matter shall be referred to the Engineer, who shall decide the same in accordance with the true intent and meaning as construed by him. Any difference or conflicts which may arise between the Contractor and any other contractor also under the contract administration of the Engineer shall be arbitrated by the Engineer.

ARTICLE 2.14 ACCESS TO WORK: The Engineer, his agents and duly authorized representatives of the CITY shall at all times and for any purpose, have access to the work and the premises used by the Contractor and the Contractor shall provide safe and proper facilities therefor.

ARTICLE 2.15 LEGAL ADDRESS OF THE CONTRACTOR: The address given in the Proposal is hereby designated as the place to which all notices, letters and other communications to the Contractor shall be mailed or delivered. The mailing or delivering to the above-named place of

any notice, letter or other communication to the Contractor, shall be deemed sufficient service thereof upon the Contractor. The date of said service shall be the date of such mailing or delivery. Such address may be changed at any time by a written notice signed by the Contractor and delivered to the Engineer.

ARTICLE 2.16 CONTRACTOR'S RESPONSIBILITIES: The Contractor shall be responsible for the safe, efficient and adequate use of equipment during the progress of the work so as to secure the safety of the workers and others. The Contractor is also responsible for the quality of work required and the stipulated rate of progress. It shall be the Contractor's responsibility to perform the work strictly in accordance with the Specifications and Plans or in accordance with modifications as may be made by the Engineer in the form of addendum or written change orders. The presence of the Public Works Inspector does not relieve the Contractor of his obligation to comply with the requirements of the Plans, Specifications and Contract Documents.

The Contractor shall assume the defense of and indemnify and save harmless the CITY and its officers and agents from all claims of any kind arising from his own negligence or that of his agents in the performance of the Contract.

The Contractor shall be responsible for the custody of any material furnished him for the care of all work until its completion and final acceptance. He shall, at his own expense, replace damaged or lost material and repair damaged parts of the work, regardless of cause, or the same may be done at the Contractor's expense by the CITY.

During the progress of the work the Contractor shall keep the worksite in a neat and clean condition and free from any unsightly accumulation of rubbish. If stockpiling is necessary, the material shall be removed or disposed of weekly. He shall remove from the vicinity of the completed work all plant, building, rubbish, unused materials, concrete forms and equipment belonging to him or used under his direction during construction. In the event of his failure to do so, the same may be removed by the CITY at the Contractor's expense.

All operations of the Contractor shall be conducted in such a manner as to avoid unnecessary dust. To this end, the Contractor shall provide equipment, materials, water, and labor to keep all parts of the work adequately sprinkled and dust free as determined by the Engineer. Full compensation for dust control measures and conforming with the provisions of this Section shall be included in the prices paid for the various contract items of work listed in the Bid Schedule, and no additional compensation will be allowed therefor.

### SECTION 3. SCOPE OF WORK

ARTICLE 3.01 WORK TO BE DONE: The Contractor shall for the price bid furnish all the necessary labor, materials, equipment, methods, processes, implements, tools, and machinery except as otherwise specified to perform the required work in a thorough and workmanlike manner in accordance with the plans and specifications, and to the satisfaction of the Engineer.

The general items of work to be performed hereunder consist of but not be limited to

**Mobilization/Demobilization; Traffic Control, Safety and Cleanup; Construction Staking and Monument Perpetuation; Storm Water Best Management Practices (BMPs); Crack Sealing; Unclassified Excavation and Disposal, Construct Rubberized AC pavement Overlay, Cold mill and Dispose of Existing Asphalt; Remove and Dispose of Existing Asphalt; Remove Existing and Construct Speed Lumps; Sawcut, Remove, and Construct Concrete Sidewalk; Sawcut, Remove, and Construct Concrete Curb and Gutter, Cross Gutters, Spandrels, and Driveways over CMB with AC Slot Trench; Sawcut and Remove Sidewalk and Ramp and Construct Curb Ramp with Detectable Warning Surface; Traffic Striping, Crosswalks, Curb Painting, Markings, and Raised Pavement Markers; Traffic Signal Loop Detectors; Adjust to Grade Water Valves, Manhole Covers; Traffic Signal Pull boxes, and Water Meter Boxes; Coordinate with Utilities for Adjust to Grade by Others; Grind Tree Roots; and all incidental work so indicated on the specifications, and required for the proposed improvements.**

ARTICLE 3.02 FINAL CLEANING UP: Before acceptance of the work and final payment therefor, the Contractor shall clean the work and all ground occupied by him in connection with the work, of all rubbish, excess materials, equipment and forms. All parts of the work shall be left in a neat and presentable condition.

ARTICLE 3.03 REPAIRS AND REPLACEMENTS: All damage done to existing facilities and improvements by the Contractor shall be repaired by him to the satisfaction of the Engineer. Where sidewalks, curbs or gutters are to be repaired, the repairs shall be made by removing and replacing the entire section back to the nearest scoring lines and not by refinishing the damaged portion.

#### SECTION 4. CONTROL OF THE WORK

ARTICLE 4.01 COORDINATION OF PLANS, SPECIFICATIONS AND SPECIAL PROVISIONS: These specifications, drawings, special provisions and all supplementary documents are essential parts of the contract. A requirement occurring in one is as binding as though occurring in all. The drawings and specifications are intended to be cooperative and to describe and provide for the workmanlike completion of proposed improvements. Refer to Subdivision 2.12.1 for precedence of Contract Documents.

ARTICLE 4.02 SPECIFICATIONS AND DRAWINGS: The Contractor shall keep at the work site a copy of the Specifications and Plans at all times and provide the Engineer access thereto.

The Contractor shall check all dimensions and quantities on the drawings or schedules herein contained or given to him by the Engineer, and shall notify the Engineer of errors therein which may be discovered by examining and checking the drawing. He shall not take advantage of any error or omission in these specifications, drawings or schedules, but should such error or omission be discovered, the Contractor shall notify the Engineer and the Contractor shall carry out the Engineer's instructions, as if originally specified.

ARTICLE 4.03 SUPERVISION BY THE CONTRACTOR: The Contractor shall give his personal superintendence to the work, using all his skills and attention in directing the performance of the work or he shall provide a competent, full-time superintendent or foreman with the authority to act on his behalf and whom shall be present to direct the work on the project at all times during its progress. All directions given to the Contractor's superintendent or other authorized supervisory employee shall be as binding as if delivered to the Contractor personally.

ARTICLE 4.04 LABOR: Any overseer, superintendent, laborer or other person employed by the Contractor who shall perform his work in a manner contrary to the specifications shall be discharged immediately and such person shall not again be employed on the project.

ARTICLE 4.05 LINES AND GRADES: The Contractor will set all lines and grades in accordance with the plans and all work done shall conform thereto. The Contractor shall dig all stake holes necessary to give lines and grades. The Contractor shall preserve all stakes set for lines, grades or measurements of the work in their proper places until authorized to remove them by the Engineer. Any expense incurred in replacing stakes which the Contractor or his subordinates may have failed to preserve shall be borne by the Contractor. Unless otherwise noted, the grade between two grade points shall be a straight line between such two points.

ARTICLE 4.06 INSPECTION: The Contractor shall notify the Engineer at least 48 hours in advance of starting or resuming work so that the Engineer can arrange for an assistant engineer or inspector to be present. Failure to give such notice shall be cause for rejection of such work. The Contractor shall furnish the engineers and inspectors reasonable facilities for obtaining such information as may be necessary to give them full information at all times respecting the progress and manner of doing the work and the character of the materials.

Subdivision 4.06.1 Special Inspection Fees: If the Contractor elects to work under this contract more than 8 hours per day and 40 hours per week; or Saturday, Sunday, overtime, or CITY Holidays, the Contractor shall arrange with the Engineer for the required inspection service and pay the special inspections fees which will be charged at the following rates:

Monday through Friday	\$105.00 / hour
Saturday, Sunday, overtime and Holidays	\$140.00 / hour

ARTICLE 4.07 DEFECTIVE WORK OR MATERIALS: Inspection of the work shall not relieve the Contractor of his obligation to fulfill his duty as herein prescribed. Defective work shall be made good by the Contractor. Unsuitable work and materials may be rejected notwithstanding that such work and materials were previously inspected by the Engineer and accepted or estimated for payment. If the work, or any part thereof, is determined to be defective at any time before final acceptance of the work, the Contractor shall forthwith make good such defect without additional compensation in a manner satisfactory to the Engineer.

If materials furnished and brought upon the job site by the Contractor for use in the work, or selected for the same by him shall be condemned by the Engineer as unsuitable or not in conformity with the Specifications, the Contractor shall forthwith discard such materials and remove them to a satisfactory distance from the vicinity of the work.

If the Contractor fails or neglects to make ordered repairs to defective work, or to remove rejected materials from the work site within 10 days after notification by the Engineer, the Engineer acting on behalf of the CITY may make the ordered repairs or remove the condemned materials and deduct the cost thereof from monies due to the Contractor.

ARTICLE 4.08 EQUIPMENT AND PLANT: Equipment not suitable to produce the quality of work required will not be permitted to operate on the project.

Plants, tools and equipment shall be designed and constructed in accordance with general practice for such equipment and shall be of sufficient capacity and of such character to insure the production of sufficient material to take the work to completion within the scheduled time frame. The Contractor shall provide adequate and suitable equipment and plants to meet the above requirements and when ordered by the Engineer shall remove unsuitable equipment from the worksite and discontinue receiving materials from unsatisfactory plants.

ARTICLE 4.09 ADDITIONS OR OMISSIONS OF WORK, LABOR OR MATERIALS:

Subdivision 4.09.1: Additions: The Contractor shall make additional excavations, furnish and place additional imported borrow, plant-mixed surfacing, concrete or do other additional work or furnish other additional materials where the necessity for or the extent of such work or materials does not appear and cannot with reasonable diligence, cost and certainty, be determined in advance or will only be disclosed by the doing of the work or in any contingency which reasonable care and consideration could not be foreseen. Such additional work or materials shall be specified in writing by the Engineer, subject to approval of the CITY COUNCIL, and shall be paid for at the unit prices set for in the contract.

Subdivision 4.09.2: Omissions: The Contractor shall omit any portion of the work, labor or materials required to be done or furnished under the plans and the specifications when the necessity for the omission of said work, labor or materials does not appear and cannot with reasonable certainty, diligence and cost be ascertained in advance or will only be disclosed by the doing of the work or in any contingency which reasonable care and consideration could be foreseen; which said omission of work, labor or materials shall be specified and required in writing by the Engineer, subject to the approval of the CITY COUNCIL, and shall be deducted from the contract price at the unit prices therefore set forth in said contract. Where the contract price is a lump sum, then the cost of the amount deducted shall be proportion of said lump sum such as the quantity of work, labor or materials omitted bears to the quantity upon which said lump sum is based.

Subdivision 4.09.3: Mark-Ups For Extra Work: The Contractor shall use the specified mark ups for all approved extra work:

For General Contractor's work, 15% mark-up for materials and equipment; and 20% mark-up for labor.

For Subcontracted work, 10% mark-up for the first \$5,000; and 5% mark-up for costs in excess of \$5,000.

Subdivision 4.09.4: Tool and Equipment Rental: The rates to be used in determining equipment rental costs shall be as listed in the Caltrans "Labor Surcharge and Equipment Rental Rates" publication in effect at the time of bid.

ARTICLE 4.10 FINAL INSPECTION: The Engineer will not make the final inspection until the work provided and contemplated by the contract has been completed and the final clean-up performed.

ARTICLE 4.11 CONTRACTOR REPORTING REQUIREMENTS: The following items shall be required as a part of Contractor payment requests. Incomplete submittal or omission of any of the following requirements shall be cause for rejection and return of payment requests to the Contractor for correction. All items shall be complete and current to the satisfaction of the Engineer. The Contractor shall provide all information for his own firm as well as each and every subcontractor. Payment requests shall include at least the following items:

- Breakdown of each pay item showing locations and quantities of work requested for payment.
- Certification that the as-built records are current and documented in writing.
- Submission of DBE information including DBE amounts completed to date, DBE providers, Monthly DBE Trucking Utilization Report, and certification that the Contractor is meeting DBE contractual requirements.
- Certified Payroll Reports.
- Updated work schedule.
- All change order requests complete to date, including all Force Account cost supporting documentation.
- Copies of all SWPPP and other Best Management Practices reports, and certification that BMP's are current and implemented.
- Copies of test results (if testing is required of Contractor).
- Survey records, maps, cut sheets, calculations, and other data.
- Subcontractor Change Requests and subcontractor data.
- Other forms or reports as may be required by contract.

ARTICLE 4.12 PENALTIES: Notwithstanding penalty provisions elsewhere in these specifications, the CITY may impose financial penalties in the case of the Contractor not fulfilling his contractual obligations. These obligations include, but are not limited to, performing work within the time limits of the contract; public notification; implementation of Best Management Practices, SWPPP, and other management plans; maintaining records; notification of the Engineer; traffic control; safety; controlling the work area; maintaining a competent supervisor on site at all times while performing work; surveying; testing; updating of schedules; and other such contractual obligations. The Contractor shall be responsible for all obligations and penalties applied to subcontractors as if he himself were performing the work.

The amount of penalty shall be equal to the daily liquidated damages, prorated for each 15 minute period, or portion of 15 minutes, of contract violation. Each violation shall be additive if multiple violations occur during the same time period.

ARTICLE 4.13 CLEANUP, TRAFFIC CONTROL, SAFETY: The Contractor shall maintain complete liability and responsibility for implementing project site cleanliness, traffic control, and safety at all times. If, in the opinion of the Engineer or his designated representative, there is a condition warranting corrective action by the Contractor, the Contractor will be advised and requested to correct the condition to the satisfaction of the Engineer. This requirement in no way absolves the Contractor of any obligation or duty to provide for the safety of persons and property at all times, nor does it impose any obligation or duty on the Engineer to provide any such services or advisement.

The Contractor's supervisor will not leave the project site until he has personally inspected and verified that all cleanliness, traffic control, and safety conditions are in a suitable condition, and has informed the Engineer that he has performed such an inspection. Likewise, no work may commence at the beginning of the work day until all cleanliness, traffic control, and safety measures and procedures have been reviewed, discussed, and implemented by the supervisor with all of the Contractor's and subcontractor's forces.

In the event that the Contractor does not immediately respond to the Engineer's request for corrective action, and the situation presents a hazard to persons and/or property, the Engineer may cause the work to be corrected by others. Likewise, in the event that the Contractor is not on site, cannot immediately respond, or is otherwise unavailable, the Engineer may cause the work to be corrected by others. If corrective work is performed by others, then the Contractor may be charged for all of the costs, including overhead and indirect costs, required to correct the work. Inspector's costs shall be per Article 4.06 INSPECTION. Engineer's costs shall be 1.5 times the noted Inspector's rate. In addition, the Engineer may impose additional penalties as provided for elsewhere in these specifications.

Full compensation for conforming to the requirements in this article shall be considered as included in the prices bid for the various contract items of work involved and no additional compensation will be allowed therefor.

ARTICLE 4.14 REMOVAL OF PERSONNEL: The Engineer reserves the right to direct the Contractor to remove any specified personnel from the project at any time without reason. If directed, the Contractor shall immediately remove such personnel from the project site, and replace such with another competent person. This requirement shall apply to subcontractor personnel as if they were the Contractor's personnel. Violation shall be subject to penalties as noted elsewhere in these specifications.

## SECTION 5. CONTROL OF MATERIAL

ARTICLE 5.01 DRAWINGS AND INFORMATION REQUIRED OF CONTRACTOR: The Contractor shall before proceeding with the fabrication or erection of structures or appurtenances if called for under the contract and required in its erection thereof, furnish the Engineer with the

information regarding same and shall submit to the Engineer for approval drawings, specifications, lists and graphs as required under these specifications. Said drawings, specifications, lists and graphs shall become the property of the CITY. In the event that the Engineer shall find that the drawings, specifications, lists and graphs as submitted by the Contractor, are in accordance with acceptable practice and meet the requirements of these specifications, the Engineer will return one (1) set of drawings and lists with his approval within 10 days after their receipt at the Engineer's office; otherwise, said drawings will be returned to the Contractor within the said 10 day period with a statement of the points wherein they have been found unsatisfactory, in which case, the Contractor at his own expense, shall proceed at once to revise said drawings and lists until they shall be found satisfactory by the Engineer and are approved by him. No fabrication shall be done prior to approval of drawings and lists. The Contractor shall have no claim for damages or extension of time on account of any delay due to revision of drawings as found necessary by the Engineer in order to fulfill the requirements of these specifications; but, regardless of such delays, the Contractor shall be liable to the CITY as provided in the specifications for any failure to complete the work as required by the terms of the contract. Revisions shown on shop drawings shall be considered as changes necessary to meet the requirements of specifications and shall not be taken as the basis of claims for extra work.

The approval of all drawings by the Engineer shall apply to general design only and shall in no way relieve the Contractor from responsibility for errors or omissions contained therein; nor shall said approval operate to waive or modify any provisions or requirement contained in these specifications.

ARTICLE 5.02 SAMPLES AND TESTS: All tests of materials furnished by the Contractor shall be made by a laboratory authorized by the Engineer to make the tests and work involved in the contract. The expense of such tests shall be included in the prices bid for the work.

Tests shall be made in accordance with commonly recognized standards of national organizations and such special methods and tests as are described in the Standard Specifications.

No material shall be used until it has been approved by the Engineer. Samples will be secured and tested whenever necessary to determine the quality of materials.

Whenever reference is made in these specifications to standard tests or requirements of the American Society for Testing Materials, the reference shall be construed to mean the standards that are in effect at the date of these specifications.

ARTICLE 5.03 STORAGE OF MATERIALS: Materials shall be so stored as to insure the preservation of their quality and fitness for the work. When considered necessary by the Engineer, they shall be placed on wooden platforms or other hard, clean surfaces and not on the ground. They shall be placed under cover when so directed. Stored materials shall be so located as to facilitate prompt inspection.

ARTICLE 5.04 SUBSTITUTION OF EQUIVALENTS: On demand of the CITY COUNCIL, the Bidder shall, at his own expense, furnish information or data concerning the article, equipment, material or process offered by him as an equivalent to that specified; and, if the CITY COUNCIL

shall so require, the Bidder, at his own expense, shall have the article, equipment, materials or process tested to its quality, strength, physical, chemical or other characteristics, its durability, finish, efficiency or service by a reputable testing engineer or laboratory satisfactory to the CITY COUNCIL.

## SECTION 6. LEGAL RELATIONS AND RESPONSIBILITIES

### ARTICLE 6.01 LAWS TO BE OBSERVED AND DISPUTE RESOLUTION:

Subdivision 6.01.1 Laws and Regulations: The Contractor shall keep himself fully informed of all Federal and State laws, County and CITY ordinances and regulations which, in any manner, affect those engaged or employed on the work, the materials used in the work or the conduct of the work. If any discrepancy or inconsistency should be discovered in this contract or in the Plans or Specifications herein referred to, in relation to any such law, ordinance or regulation, the Contractor shall forthwith report the same in writing to the Engineer. The Contractor shall, at all times, observe and comply with and shall cause all his agents and employees to observe and comply with all such applicable laws, ordinances and regulations in effect or which may become effective before completion of this contract. He shall protect and indemnify the CITY and its officers and agents against any claim or liability arising from or based on the violations of any such laws, ordinances or regulations whether by himself or by his employees or his subcontractors or their employees.

Except as otherwise explicitly provided in these specifications, all permits and licenses necessary to the prosecution of the work shall be secured by the Contractor at his own expense and he shall pay all taxes properly assessed against his equipment or property used or required in connection with the work.

All state laws, all county and CITY ordinances and regulations now imposed by competent authority and relating to any materials required to be furnished under these specifications and work required to be done hereunder, shall be deemed to be and hereby are made controlling and part of these specifications.

Subdivision 6.01.2 General: The Contractor shall keep himself fully informed of all existing state and national laws and municipal ordinances and regulations which in any manner affect those engaged or employed in the work, or the materials used in the work or which in any way affect the conduct of the work and of all such orders and decrees of bodies or tribunals having any jurisdiction or authority over the same.

Subdivision 6.01.3 Eight-Hour Law: Eight (8) hours labor constitutes a legal day's work. The Contractor shall forfeit as a penalty twenty-five dollars (\$25.00) for each workman employed in the execution of the contract by the Contractor or any subcontractor under him for each calendar day during which such workman is required or permitted to work more than eight (8) hours in any one calendar day and forty (40) hours in any one calendar week in violation of the provisions of the Labor Code and in particular, Section 1810 to Section 1815 thereof inclusive except that work performed by employees of Contractors in excess of eight (8) hours per day and forty (40) hours

during any one week, shall be compensated at not less than one and one-half (1 ½) times the basic rate of pay as provided in Section 1815.

Subdivision 6.01.4 Prevailing Rate of Per Diem Wages: Pursuant to the provisions of Section 1773 of the Labor Code of the State of California, the Director of Industrial Relations has ascertained the general prevailing rate of wages and employer payments for health and welfare, vacation, pension and similar purposes applicable to the work to be done.

The Contractor shall comply with Labor Code Section 1775. In accordance with said section, the Contractor shall forfeit as a penalty to the CITY fifty dollars (\$50.00) for each calendar day, or portion thereof, for each workman paid less than the stipulated prevailing rates for such work or craft in which such workman is employed for any work done under the contract by him or by any subcontractor under him in violation of the provisions of the Labor Code and in particular Labor Code Sections 1770 to 1780, inclusive. In addition to said penalty and pursuant to said Section 1775, the difference between such stipulated prevailing wage rates and the amount paid to each workman for each calendar day or portion thereof for which each workman was paid less than the stipulated prevailing wage rate shall be paid to each workman by the Contractor.

Subdivision 6.01.5 Certified Payroll: Pursuant to Section 1776 of the Labor Code, the Contractor and/or subcontractors shall submit weekly to the CITY for each week in which any contract work is performed a certified copy of all payroll records. Should the Contractor fail to provide such payroll certificates, the CITY may withhold one thousand dollars (\$1,000) for each weekly payroll certificate not received from payment due.

Subdivision 6.01.6 Governing Law, Venue, Dispute Resolution and Attorneys' Fees: This Agreement will be governed by and construed in accordance with laws of the State of California. Specifically, Government Code Section 9204 (A summary of which is set forth in Subdivision 6.01.7). If any disputed portion of the claim is not resolved with the procedure set forth in Subdivision 6.01.7 herein, prior to commencing suit in a court of competent jurisdiction, any unresolved portion of any controversy, dispute or claim arising out of the Agreement will first be submitted to an alternative dispute resolution process as set forth in Subdivision 6.01.8 herein. Any action at law or in equity brought by either of the parties hereto for the purpose of enforcing a right or rights provided for by this Agreement will be tried in a court of competent jurisdiction in the County of Orange, State of California. In the event either party hereto will bring suit to enforce any term of this Agreement or to recover any damages for and on account of the breach of any term or condition of this Agreement, it is mutually agreed that the prevailing party in such action will recover all costs thereof, including reasonable attorneys' fees, to be set by the court in such action.

Subdivision 6.01.7 Summary of Government Code Section 9204: A "claim" is a separate demand on the CITY by a Contractor on a public works project and sent by registered mail or certified mail with return receipt requested, for one or more of the following:

- A time extension, including relief from penalties for delay;
- Payment by the CITY of money damages under the terms of the contract;
- Payment of an amount that is disputed by the CITY.

Initial Review. The claim must be supported by appropriate documentation. The CITY has forty-five (45) days within which to review the claim and provide the Contractor with a written statement identifying the disputed and undisputed portions of the claim. If the CITY does not issue a written statement, the claim is deemed rejected in its entirety. The CITY will pay any undisputed portion of the claim within sixty (60) days of issuing the statement.

Meet & Confer. If the Contractor disputes the CITY's written response, or if the CITY does not issue one, the Contractor may request in writing an informal conference to meet and confer for possible settlement of the claim. The CITY will schedule the meet and confer conference within thirty (30) days of this request and provide a written statement identifying the remaining disputed and undisputed portions of the claim within ten (10) business days of the meet and confer. The CITY will pay the undisputed portion within sixty (60) days of issuing this statement.

Mediation. With respect to any disputed portion remaining after the meet and confer, the CITY and Contractor must submit the matter to nonbinding mediation, agree to a mediator within ten (10) business days after issuing the written statement, and share mediation costs equally. If mediation is unsuccessful, then the terms of the public works agreement and applicable law will govern resolution of the dispute.

Miscellaneous Provisions. Amounts not paid by the CITY in a timely manner bear interest at 7% per annum. Subcontractors may submit claims via this procedure through the general contractor. The CITY and Contractor may waive the requirement to mediate, but cannot otherwise waive these claim procedures.

Subdivision 6.01.8 Alternative Dispute Resolution: In the event that there is any controversy, dispute or claim arising out of or relating to this Agreement, which have not been resolved pursuant to the process summarized in Subdivision 6.01.7 herein, the parties hereto will consult and negotiate with each other and, recognizing their mutual interest, attempt to reach a solution satisfactory to both parties. If they do not reach settlement within a period of sixty (60) days, the matter will be submitted to nonbinding arbitration ("Process") by written notice from either party to the other. The parties will meet and confer in good faith and select an arbitrator that is agreeable to both sides. The Process will be completed no later than one hundred twenty (120) days ("Process Period") after tender of the aforementioned written notice, unless the Parties mutually agree to an extension of the Process Period. If the matter is not successfully resolved by the Process, within the Process Period, the parties are free to commence litigation in a court of competent jurisdiction as defined in Subdivision 6.01.6 herein. Any litigation commenced without both parties' consent prior to the end of the Process Period, will be subject to a stay until the end of the Process Period. The Parties further agree to equally bear the cost of the Process.

ARTICLE 6.02 PERMITS AND LICENSES: The Contractor shall procure all permits and licenses, pay all charges and fees, and give all notice necessary and incident to the due and lawful prosecution of the work. No fee is charged for an Encroachment Permit issued by the CITY for a Public Works Project. The Contractor and his subcontractors shall obtain a CITY Business License.

Full compensation for conforming to the requirements in this article shall be considered as included in the price bid for the various contract items of work involved and no additional compensation will be allowed therefor.

ARTICLE 6.03 PATENTS: The Contractor shall assume all costs arising from use of patented materials, equipment, devices or processes used on or incorporated in the work and agrees to indemnify and save harmless the CITY, the CITY COUNCIL, the City Engineer and their fully authorized representatives from all suits of law or actions of every nature for, or on account of, the use of any patented materials, equipment, devices or processes.

ARTICLE 6.04 PRESERVATION OF PROPERTY: The Contractor shall conduct the operations in a careful and prudent manner to avoid damage to adjacent property.

The Contractor shall preserve and protect all on-site and roadside trees from injury. All trees useful for shade or other purposes shall be cared for by the Contractor and no trees within the limits of project site shall be cut or removed unless indicated on the plans.

All fences along the line of the improvement shall be protected by the Contractor; if they are injured or destroyed they shall be restored to a condition as good as when he entered upon the work. It is required that the Contractor replace in kind or reimburse the owners thereof for all fences, shrubs, buildings and other improvements damaged or removed by the construction operations not shown on the plans.

The Contractor shall preserve and protect from damage to all buildings, pole lines, pipe lines and all direction, warning and mileage signs and any other structures which have been placed within the limits of the project site.

Full compensation for conforming to the requirements in this article shall be considered as included in the price bid for the various contract items of work involved and no additional compensation will be allowed therefor.

ARTICLE 6.05 PRESERVATION OF MONUMENTS: The Contractor shall not disturb any monuments, stakes or sign posts found on the line of the improvement until authorized by the Engineer. The Contractor shall bear the expense of resetting any monument, stakes or sign posts which may be disturbed without authorization from the Engineer. After construction and prior to final acceptance, the Contractor's land surveyor or qualified Civil Engineer shall re-survey all field monuments and centerline ties within the construction zone, prepare tie sheets and Corner Record sheets, and file them with the City Engineer for review. After review by the City Engineer, the land surveyor shall file the Corner Records with the Orange County Land Surveyors Office as required by law, and file certified copies of the Corner Records with the City Engineer. Project retention will not be released until all records are recorded with the County Land Surveyor Office.

ARTICLE 6.06 RESPONSIBILITY FOR DAMAGE: During the progress of the work, the CITY will not be answerable or accountable, in any manner, for any loss or damage that may happen to the work or any part thereof; or for injury to any person or persons, either workmen or the public, or for damage to adjoining property from any cause which might have been prevented by the

Contractor or his workmen or any one employed by him, against all of which injuries or damages to persons and property the Contractor having control over such work must properly guard. The Contractor shall be responsible for any damage to any person or property resulting from defects or obstructions or from any causes whatsoever during the progress of the work, or at any time before its completion and final acceptance and shall indemnify and save harmless the CITY and/or its officers and/or its employees from all suits or actions of every name and description brought for or on account of any injuries or damages received or sustained by any person or persons by or from the Contractor, his servants or agents in the construction of the work or by or in consequence of any negligence in guarding the same in improper materials used in its construction or by or on account of any act or omission of the Contractor or his agents.

ARTICLE 6.07 COOPERATION BETWEEN CONTRACTORS: Where two or more contractors are employed on related or adjacent work, each shall conduct his operations in such a manner as not to cause any unnecessary delay or hindrance to the other. Each contractor shall be responsible to the other for all damage to work, person or property or for loss caused by failure to finish the work within the time specified for completion.

ARTICLE 6.08 CONTRACTOR'S RESPONSIBILITY FOR WORK: Except as provided above, until the formal acceptance of the work by the CITY COUNCIL, the Contractor shall have the charge and care thereof and shall bear the risk of injury or damage to any part thereof by the action of the elements or from any other cause whether arising from the execution or from the non-execution of the work. The Contractor shall rebuild, repair, restore and make good all injuries or damages to any portion of the work occasioned by any of the above causes before its completion and acceptance and shall bear the expense thereof except for such injuries or damages as occasioned by acts of the Federal Government and the public enemy. In case of suspension of work from any cause whatever, the Contractor shall be responsible for all materials and shall properly store them, if necessary, and shall provide suitable drainage of the project site and erect temporary structures where necessary.

ARTICLE 6.09 NO PERSONAL LIABILITY: Before the contract is executed on behalf of the CITY, a bidder to whom the contract has been awarded shall furnish to the CITY a policy or certificate of protective liability insurance in which the CITY shall be named as an additional insured with the bidder. The policy shall insure the CITY, his officers, and his employees; the bidder, his employees and his subcontractors and their employees, their heirs, agents and employees; while acting within the scope of their duties against all claims arising out of or in connection with the work to be performed and shall remain in full force and effect until the work is accepted by the CITY. The policy shall provide for the following limits:

Minimum Scope of Insurance.

- (a) **Commercial General Liability (CGL)** which affords coverage at least as broad as Insurance Services Office "occurrence" form CG 00 01, including products and completed operations, property damage, bodily injury, and personal & advertising injury with limits no less than \$5,000,000 per occurrence. If a general aggregate limit applies, either the

general aggregate limit shall apply separately to this project/location or the general aggregate limit shall be twice the required occurrence limit.

**Products-Completed Operations:** CONTRACTOR shall procure and submit to City evidence of insurance for a period of at least ten (10) years from the time that all work under this Contract is completed.

- (b) **Automobile Liability Insurance** with coverage at least as broad as Insurance Services Office Form CA 0001 covering "Any Auto" (Symbol 1) with limit no less than \$5,000,000 each accident for bodily injury and property damage.
- (c) **Workers' Compensation** as required by the State of California with statutory limits, and Employer's Liability Insurance with a limit of not less than \$1,000,000 per accident for bodily injury or disease.
- (d) **Builder's Risk Insurance** for any property constructed on behalf of the City, to cover "all risk" of physical loss providing coverage for loss or damage from collapse, including collapse resulting from builder's design error. All property stored off-site or in transit must be covered. The value insured shall cover 100% of the completed Contract cost, including Boiler & Machinery and Soft Costs and shall be maintained until full acceptance of the Work. Proceeds payable under the above insurance shall be fully payable to the City as Loss Payee.
- (e) **CONTRACTOR'S Pollution Legal Liability Legal Liability and/or Asbestos Pollution Liability and/or Professional Liability** covering all of the CONTRACTOR'S operations to include onsite and offsite coverage for bodily injury (including death and mental anguish), property damage, non-owned disposal site liability, defense costs, cleanup costs, and pollution conditions that arise from or in connection with the transportation (including loading and unloading) by or on behalf of the CONTRACTOR, of any waste or waste materials off or away from the project site. Coverage shall be provided for both sudden and accidental and gradual and continuous pollution events with limits no less than \$5,000,000 each loss and \$10,000,000 in the aggregate. The policy shall not exclude any hazardous materials for which there is an exposure.

All insurance issued in compliance with this section shall be insured in the form and by the insurer or insurers satisfactory to and first approved by the CITY in writing. The Contractor shall not allow any subcontractor to commence work on his subcontract until the subcontractor has secured all required bonds and insurance.

**ARTICLE 6.10 WORKER'S COMPENSATION INSURANCE:** The Contractor shall procure and maintain Worker's Compensation Insurance as required by applicable state or territorial law for all of his employees to be engaged in work at the site of the project under this Contract. In case of any such work sublet, the Contractor shall require the subcontractor similarly to provide Worker's Compensation Insurance for all of the latter's employees to be engaged in such work unless such employees are covered by the protection afforded by the Contractor's Worker's Compensation Insurance. In case any class of employees engaged in hazardous work on the project under this Contract is not protected under the Worker's Compensation Statute, the Contractor shall provide and shall cause each subcontractor to provide adequate employer's liability insurance for the protection of such of his employees as are not otherwise protected.

The Contractor and/or subcontractor shall file a copy of their Certificate of Compensation Insurance with the CITY and no work shall begin until such certificate is filed with the CITY. In the event of cancellation, the insurance company shall give the CITY ten (10) days written notice.

**ARTICLE 6.11 SUBCONTRACTING:** Attention is directed to the provisions in Section 1-6.2, "Subcontractor Listing", of the Standard Specifications and these Special Provisions.

In accordance with the requirements of Sections 4100 to 4133 inclusive of the Public Contract Code, each bidder shall list in his Proposal the name and business address of each subcontractor to whom the bidder proposes to subcontract all or a portion of work and shall list each subcontractor licensed by the State of California proposed by the bidder to specially fabricate and install all or a portion of the work. Said list shall include a description of the portion of the work which will be done by each subcontractor.

A sheet for listing the subcontractors as required is included in the proposal. The successful responsible bidder shall submit a letter to the CITY requesting approval of all subcontractors. Included in the letter shall be a list of the names and addresses of each Contractor, items to be subcontracted by item number, brief description of the item, and contract bid value. If only a portion of the item is to be subcontracted, that portion and dollar value of work, based on contract item bid value, shall be indicated.

No subcontractor shall be permitted to perform any work under the contract without having first been approved, in writing, by the CITY.

**ARTICLE 6.12 TRESPASS:** The Contractor shall be responsible for all damage or injury which may be caused on any property by trespass of the Contractor's employees in the course of their employment whether the said trespass was committed with or without the consent or knowledge of the Contractor.

**ARTICLE 6.13 SAFETY, SANITARY AND MEDICAL REQUIREMENTS:** The Contractor, his employees, his subcontractors and their employees shall promptly and fully carry out the existing safety, sanitary and medical requirements as may from time to time be prescribed by the Industrial Safety Commission and by County or State Health Departments to the end that proper work shall be done and the safety and health of the employees and of the community may be

conserved and safeguarded. In case any such regulations and orders are not observed by the Contractor, they may be enforced by the Engineer at the Contractor's expense.

ARTICLE 6.14 WATER AND POWER: Unless otherwise provided in the Special Provisions, the Contractor shall provide, at his own expense, all necessary water and power required for his operations under the contract.

ARTICLE 6.15 PROTECTION OF UNDERGROUND FACILITIES: Attention is directed to the possible existence of underground facilities not known to the CITY or in a location different from that which is indicated on the plans or in these Special Provisions. The Contractor shall take steps to ascertain the exact location of all underground facilities prior to doing work that may damage such facilities or interfere with their service. If the Contractor discovers underground facilities not indicated on the Plans or in these Special Provisions, he shall immediately give the Engineer written notification of the existence of such facilities. Such facilities shall be protected from damage as directed by the Engineer and the Contractor will be paid for such work as extra work as provided in Section 7-4 "Payment for Extra Work" of the Standard Specifications.

ARTICLE 6.16 AIR POLLUTION CONTROL: Section 3-12.2, "Air Pollution Control", of the Standard Specifications is supplemented by the following:

The Contractor shall comply with all air pollution control rules, regulations, ordinances and statutes which apply to any work performed pursuant to the contract including any air pollution control rules, regulations, ordinances and statutes specified in Section 11017 of the Government Code.

In the absence of any applicable air pollution control rules, regulations, ordinances or statutes governing solvents, all solvents, including but not limited to the solvent portions of paints, thinners, curing compounds, and liquid asphalt used on the project shall comply with the applicable material requirements of the County Air Pollution Control District. All containers of paint, thinner, curing compound or liquid asphalt shall be labeled to indicate that the contents fully comply with said requirements.

Full compensation for conforming to the requirements in this article shall be considered as included in the price bid for the various contract items of work involved and no additional compensation will be allowed therefor.

ARTICLE 6.17 PROJECT APPEARANCE: The Contractor shall maintain a neat appearance to the work. In any area visible to the public, the following shall apply:

When practicable, broken concrete and debris developed shall be disposed of concurrently with its removal. If stockpiling is necessary the material shall be removed or disposed of on the next working day, except that stockpiles shall not be left in the public right of way on weekends or holidays.

Full compensation for conforming to the requirements in this article shall be considered as included in the prices bid for the various contract items of work involved and no additional compensation will be allowed therefor.

ARTICLE 6.18 FAIR EMPLOYMENT PRACTICE COMMISSION CERTIFICATION: The Contractor's attention is directed to the requirements in Section 12990 of the Government Code for nondiscrimination and compliance employment programs.

ARTICLE 6.19 SOUND CONTROL REQUIREMENTS: The Contractor shall comply with all local sound control and noise level rules, regulations and ordinances which apply to any work performed pursuant to the Contract.

Each internal combustion engine used for any purpose on the job or related to the job shall be equipped with a muffler of a type recommended by the manufacturer. No internal combustion engine shall be operated on the project without said muffler.

The noise level from the Contractor's operations between the hours of 7:00 a.m. and 4:00 p.m. shall not exceed 86 DBA at a distance of 50 feet. This requirement in no way relieves the Contractor from responsibility for complying with local ordinances regulating noise level.

Said noise level requirement shall apply to all equipment on the job or related to the job including, but not limited to, trucks, transit mixers or transient equipment that may or may not be owned by the Contractor. The use of loud sound signals shall be avoided in favor of light warnings except those required by safety laws for the protection of personnel.

Full compensation for conforming to the requirements in this article shall be considered as included in the prices bid for the various contract items of work involved and no additional compensation will be allowed therefor.

ARTICLE 6.20 LEGAL RELATIONS AND RESPONSIBILITY: The Contractor's attention is directed to the provisions of Section 5, "Legal Relations and Responsibilities", of the Standard Specifications and these Special Provisions for the requirements and conditions which he must observe in the execution of the work.

## SECTION 7. PROSECUTION AND PROGRESS

ARTICLE 7.01 PROSECUTION AND PROGRESS: The Contractor's attention is directed to Section 6, "Prosecution and Progress of the Work", of the Standard Specifications.

ARTICLE 7.02 TIME LIMIT: The work specified herein and shown on the Plans and Specifications shall be completed within **fifty (50) working days** from the start date specified in the Notice to Proceed. Attention is directed to Section 3-13 and 6-9 of the Standard Specifications for Public Works Construction (The "Greenbook"), "Completion, Acceptance, and Warranty"; and "Liquidated Damages". The CITY shall withhold liquidated damages before the accrual date if the anticipated liquidated damages may exceed the value of the remaining work. Liquidated damages for all work except plant establishment are as shown in the following table:

If the total amount of working days have expired and the work is not complete, liquidated damages are three thousand dollars (\$3000.00) per calendar day.

#### SECTION 8. PAYMENTS

Within fifteen (15) workdays after the date of acceptance of the work the Engineer will cause to be filed on behalf of the CITY in the Office of the County Recorder a Notice of Completion of the work herein agreed to be done by the Contractor.

Upon expiration of forty-five (45) days after the filing of such Notice of Completion of the work, the CITY will pay to the Contractor the amount remaining after deduction from the amount of value stated in the above-mentioned estimate all prior payments to the contract and all amounts to be kept and retained under the provisions of the Contract.

If the Contractor disagrees with the Engineer's final estimate and within said period of forty-five (45) days files a written statement of his claims, the Engineer will issue as a semi-final estimate the proposed estimate submitted to the Contractor and the CITY will within thirty (30) days pay the sum found due thereon after deducting from the amount of value stated in the first mentioned estimate all prior payments to the Contractor and all amounts to be kept and retained under the provisions of the contract. The Engineer will then consider and investigate the Contractor's claim and will make such revision in the said estimate as he may find to be due and will then certify in writing to the City Clerk the whole amount and value of the work done by the Contractor under and according to the terms of the contract. The CITY will pay the amount so found due after deducting all previous payments, amounts to be retained under the contract, and amounts which may be retained in accordance with the applicable specifications.

ARTICLE 8.01 PARTIAL PAYMENTS: At the request of the Contractor, partial payments will be made on a monthly basis. The Progress Pay requests shall be submitted on or before the 20<sup>th</sup> day of each month. The estimate may include only work completed up to and including this date.

Progress pay requests showing work not accomplished by the 20<sup>th</sup> day of the month shall be rejected.

ARTICLE 8.02 PAY RETENTION: From each progress estimate **five percent (5%)** will be deducted and retained in accordance with Section 7-3.2 of the Standard Specifications.

ARTICLE 8.03 FINAL ESTIMATE AND PAYMENT: Whenever in the opinion of the Engineer the Contractor shall have completely performed the contract on his part the Contractor shall submit to the Engineer a written statement to the final quantities of contract items for inclusion in the final estimate.

All prior estimates upon which partial payments have been made shall be subject to correction in the final estimate. The final estimate and payments made thereunder shall be final and conclusive upon the Contractor.

ARTICLE 8.04 TAXES: No mention shall be made of sales tax or use tax, as all bid prices submitted shall be considered as including such tax.

## SECTION 9. WORK SCHEDULES

ARTICLE 9.01 WORK SCHEDULE: Before the commencement of work, the Contractor shall submit a work schedule prepared using the latest version of Microsoft Project or approved equal to the Engineer for approval. The work schedule shall be submitted at least five (5) days prior to commencement of work or at the Pre-Construction Meeting, and shall be kept current through the progress of the work. The work shall be performed in order of their priorities and as directed by the Engineer.

The Contractor shall schedule his work so that all excavated locations shall be poured concrete no later than Friday. The Contractor shall not excavate any location that he is not sure that he is able to pour on Friday. No excavated location is allowed over weekends and / or holidays. The Contractor shall pay the sum of one hundred dollars (\$500.00) per each calendar day for each excavation left open and not poured concrete over the weekend starting on Saturday or over a holiday for the sidewalk portion of the work.

Full compensation for conforming to the requirements in this article shall be considered as included in the prices bid for the various contract items of work involved and no additional compensation will be allowed therefor.

## SECTION 10. CITY REQUIREMENTS

ARTICLE 10.01 FAIR EMPLOYMENT PRACTICES: In connection with the performance of work under this Contract, the Contractor agrees as follows:

1. The Contractor will not willfully discriminate against any employee or applicant for employment because of race, sex, color, religion, age, handicap status, or national origin. The Contractor will take affirmative action to ensure that the applicants are employed, and that employees are treated during employment, without regard to their race, sex, color, religion, age, handicap status, or national origin. Such action shall include, but not be limited to, the following: employment upgrading, demotion or transfer; recruitment or recruitment advertising; layoff or termination; rates of pay or other forms of compensation; and selection for training, including apprenticeship. The Contractor agrees to post in conspicuous places, available to employees and applicants for employment, notices to be provided by awarding authority setting forth the provisions of this fair Employment Practices section.
2. The Contractor will send to each labor union or representative of workers with which he has collective bargaining agreement or other contract or understanding, a notice advising the said labor union workers' representative of the Contractor's commitments under this section, and shall post copies of the notice in conspicuous places available to employees and applications for employment.

3. The Contractor will permit access to his records of employment, employment advertisements, application forms, and other pertinent data and records the Fair Employment Practices Commission, the CITY or any other appropriate agency designated by the CITY for the purposes of investigation to ascertain compliance with the Fair Employment Practices section of this Contract.
4. The finding of willful violation of the Fair Employment practices section of this Contract or of the Fair Employment Practices Act shall be regarded by the CITY as a basis for determining the Contractor to be not a "responsible bidder" as to future contracts for which such Contractor may submit bids.

The CITY shall deem a finding of willful violation of the Fair Employment Practices Act to have occurred upon receipt of written notice from the Fair Employment Practices Commission that it has investigated and determined that the Contractor has violated the Fair Employment Practices Act and has issued an order under Government Code Section 12970 or obtained an injunction under the Government Code Section 12973.

Upon receipt of such written notice from the Fair Employment Practices Commission, the CITY shall notify the Contractor that unless he demonstrates to the satisfaction of the awarding authority within a stated period that the violation has been corrected, his prequalification rating will be revoked at the expiration of such period.

5. The Contractor agrees, that should the CITY determine that the Contractor has not complied with the Fair Employment Practices section of this Contract, then pursuant to Labor Code Section 1735 and 1755, the Contractor shall, as a penalty to the Agency, forfeit for each calendar day, or portions thereof, for each person who was denied employment as a result of such non-compliance, the penalties provided in the Labor Code for violation of prevailing wage rates. Such monies may be recovered from the Contractor. The Agency may deduct any such damages from any monies due to the Contractor from the Contract.
6.
  - a. Nothing contained in this Fair Employment Practices section shall be construed in any manner or fashion so as to prevent the CITY from pursuing any other remedies that may be available by law.
  - b. Nothing contained in this Fair Employment Practices section shall be construed in any manner or fashion so as to require or permit the hiring of an employee not permitted by the National Labor Relations Act.
7. Prior to award of the Contract, the Contractor shall certify to the awarding authority that he has or will meet the following standards for affirmative compliance which shall be evaluated in each case by the CITY.
  - a. The Contractor shall provide evidence, as required by the CITY, that he has notified all supervisors, foremen and other personnel officers in writing of the content of the anti-discrimination clause and their responsibilities under it.

- b. The Contractor shall provide evidence, as required by the CITY, that he has notified all sources of employee referrals (including unions, employment agencies, advertisements, Department of Employment) of the content of the anti-discrimination clause.
  - c. Personally, or through his representatives, the Contractor shall, through negotiations with the unions with whom he has agreements, attempt to develop an agreement which will:
    - (1) Spell out responsibilities for non-discrimination in hiring, referral, upgrading and training.
    - (2) Otherwise implement an affirmative anti-discrimination program in terms of the union's specific areas of skill and geography, to the end that qualified minority workers will be available and given an equal opportunity for employment.
  - d. The Contractor shall notify the CITY of opposition to the anti-discrimination clause by individuals, firms or organizations during the period of its prequalification.
8. The Contractor will include the provisions of the foregoing paragraphs 1 through 7 in every first tier subcontract, so that such provisions will be binding upon each such subcontractor.
9. The Contractor, in executing the proposal, thereby certifies that he has or will meet the standards for affirmative compliance with the Fair Employment Practices requirements contained herein.
10. The Contractor shall comply with the procedures and conditions set forth in Section XII of the City of La Habra Affirmative Action Plan as adopted by Resolution 2404 of the City of La Habra January 21, 1975, a portion of which reads as follows:

“It shall be the policy of the City of La Habra to require all contractors and vendors doing business with the CITY in an amount in excess of \$50,000.00 and/or 200 employees to certify their compliance with Title VII of the civil Rights Act and the Equal Employment Opportunity Act of 1972. Said certification shall be stipulated by the CITY to safeguard against discrimination by contractors or vendors on the basis of race, color, creed, sex, age, or nationality concerning the practices of recruitment, promotion, demotion, transfer, layoff, or termination. A violation of this non-discrimination certification will be considered a material provision violation and shall be grounds for termination or suspension, in whole or in part, of the contract by the CITY”.

## SECTION 11. CONSTRUCTION DETAILS

### ARTICLE 11.01 GENERAL:

Subdivision 11.01.1 Description of Work: The general items of work to be performed hereunder shall be in various locations throughout the CITY, comprises the furnishing of all materials, equipment, tools, labor and incidentals and shall consist of but not be limited to

**Mobilization/Demobilization; Traffic Control, Safety and Cleanup; Construction Staking and Monument Perpetuation; Storm Water Best Management Practices (BMPs); Crack Sealing; Unclassified Excavation and Disposal, Construct Rubberized AC pavement Overlay, Cold mill and Dispose of Existing Asphalt; Remove and Dispose of Existing Asphalt; Remove Existing and Construct Speed Lumps; Sawcut, Remove, and Construct Concrete Sidewalk; Sawcut, Remove, and Construct Concrete Curb and Gutter, Cross Gutters, Spandrels, and Driveways over CMB with AC Slot Trench; Sawcut and Remove Sidewalk and Ramp and Construct Curb Ramp with Detectable Warning Surface; Traffic Striping, Crosswalks, Curb Painting, Markings, and Raised Pavement Markers; Traffic Signal Loop Detectors; Adjust to Grade Water Valves, Manhole Covers; Traffic Signal Pull boxes, and Water Meter Boxes; Coordinate with Utilities for Adjust to Grade by Others; Grind Tree Roots; and all incidental work so indicated on the specifications, and required for the proposed improvements.**

Subdivision 11.01.2 Order of Work: Order of work shall conform to the provisions of Section 6-1, "Construction Schedule and Commencement of the Work," of the Standard Specifications for Public Works Construction (The "Greenbook") and these Special Provisions.

**The Contractor shall determine the sequence of work necessary to diligently pursue completion of the work, in accordance with the Special Provisions. Work shall be phased and constructed so that at the end of each work day, excavated trenches will be covered flush to grade by steel plates or pavement, opened to traffic, and parking restored. For cold milling, the Contractor shall mill only the quantity of street that the Contractor can base pave the same working day. Open trenches adjacent to sidewalks shall be covered and protected for pedestrian traffic (such as water meters and fire hydrants). No open parkway excavation will be allowed over weekends. Sidewalks shall be ramped or filled to grade during the week.**

- 1. Procurement of all materials requiring long lead-time. The Contractor shall order all long lead-time supplies, materials and equipment within ten (10) working days after the award of contract by the CITY.**
- 2. Develop and set up traffic control measures.**
- 3. Install initial project storm water pollution prevention plan and BMPs.**
- 4. Complete all required excavation.**
- 5. Complete all backfill, compaction, T-cuts, AC cap and pavement restoration.**
- 6. Complete all concrete improvements.**
- 7. Complete all street improvements.**
- 8. Adjust surface utilities and manholes to grade.**

**9. Complete signing, striping, pavement markings and traffic loops.**

Subdivision 11.01.3 Public Convenience and Access: The Contractor shall conduct his operations so as to cause minimum obstruction and inconvenience to the public.

At least five (5) days prior to commencing work, the Contractor shall submit to the Engineer his construction schedule for approval in accordance with Section 9. This schedule shall allow businesses and residents on the affected streets to park within a reasonable distance from their business or home. The Contractor shall distribute to each resident or business affected by the construction a written notice at least 5 days prior to commencing construction. The notice shall include the date and working hours of construction. It shall be the Contractor's responsibility to complete the notification letter with the proper dates at the time of notification. If the Contractor fails to meet the schedule indicated in the Notice, the Contractor shall reschedule his work and re-notify the residents.

Continuous emergency and local traffic access shall be maintained in the area of work and vehicular access to individual driveways shall be provided and maintained except for short durations of not more than two hours and with prior notice to the adjacent residents involved. No overnight closure of driveways will be allowed except while construction is in progress and concrete is curing. The Contractor shall provide alternate ramps for access while concrete is curing, where feasible.

Should the Contractor appear to be neglectful or negligent in furnishing warning and protective measures, the Engineer may direct the Contractor's attention to the existence of such hazards. The Contractor shall provide all necessary warning and protective measures immediately, at his expense. Whether the Engineer points out the inadequacy of warning and protective measures or not, such action, or lack of action, on the part of the Engineer shall not relieve the Contractor from the responsibility for public safety or abrogate his obligation to furnish and pay for safety measures and devices. If attention is directed to the existence of a hazard, and the Contractor fails to provide an appropriate remedy, any expense incurred by the CITY for furnishing or maintaining safety measures and devices may be deducted from the pay estimates and the total contract price for the work.

The Contractor shall maintain access for residents at all times during the construction and at the end of each work day as specified above. The travel lanes shall be graded smooth and shall be maintained in a smooth condition throughout the period of construction including weekends, and at times as directed by the Engineer.

The Contractor shall be responsible for maintaining location of, and access to, all utilities and underground facilities during construction operations, including but not limited to valves and monitoring wells.

Subdivision 11.01.4 Public Notice: The Contractor shall notify businesses and residents affected by the construction in writing not less than 5 days advance of commencement of demolition, construction, or storage of materials in the street. The notice shall include but not be limited to:

1. Time and Date of Commencement.
2. Working Hours of Construction.
3. Date of Completion.
4. Name & Telephone Number of Person to be Contacted, at any hour, in the event of a condition requiring immediate correction.

A copy of the letter shall be submitted to the City Engineer for approval prior to distribution.

The Contractor shall also notify La Habra Police Department, Los Angeles County Fire Department, Trash Hauler, Post Office, Ambulance Service, La Habra City School District, and Orange County Transportation Authority about the construction. It shall be the Contractor's responsibility to complete the notification letter, with the proper dates, at the time of notification. If the Contractor fails to meet the schedule indicated in the Notice, the Contractor shall reschedule his work and re-notify all those listed above.

Subdivision 11.01.5 Hours of Work: All work shall be performed between 7:00 A.M. and 4:00 P.M., Mondays through Fridays except holidays. No work shall be performed outside normal working hours without advanced authorization from the Engineer. If work is adjacent to a school or on a major arterial, working hours will be restricted to **9:00 A.M. and 3:00 P.M.** for lane closures, Mondays through Fridays except holidays. For any inspection outside of regular working hours, the Contractor shall pay all costs for the inspector's time. Request for overtime inspection shall be made in writing to the Engineer.

Full compensation for conforming to the requirements in this article shall be considered as included in the prices bid for the various contract items of work involved and no additional compensation will be allowed therefor.

ARTICLE 11.02 FURNISH AND APPLY WATER: Should the Contractor require water for construction operations, such as for compaction and dust control, he may use water from any fire hydrant adjacent to the job site upon application of a "No Fee" permit from the CITY, Engineering Department. The Contractor shall apply water for dust control as necessary and as directed by the Engineer.

Prior to using water, the Contractor shall install a water meter, a valve and an approved back-flow prevention device on the fire hydrant at his expense. The Contractor shall notify Los Angeles County Fire Department and the Public Works Department twenty-four (24) hours in advance, stating the location of the hydrant and the hours when it will be used. The Contractor shall operate the fire hydrant with a hydrant wrench only. Should damage occur to the hydrant, the Contractor shall make repairs at his expense and/or further use of CITY Water may be prohibited. The meter will be used for monitoring water use only. The Contractor will not be charged for water used on the project.

Full compensation for conforming to the requirements in this article shall be considered as included in the prices bid for the various contract items of work involved and no additional compensation will be allowed therefor.

ARTICLE 11.03 DUST CONTROL: The Contractor shall at all times, including weekends, at his expense, control dust on the project. Should the Contractor fail to maintain adequate dust control, the CITY will maintain the site, and an amount equal to twice the actual cost shall be assessed to the Contractor.

Full compensation for conforming to the requirements in this article shall be considered as included in the prices bid for the various contract items of work involved and no additional compensation will be allowed therefor.

ARTICLE 11.04 EXCESS EXCAVATED MATERIAL: Excess excavated material shall be removed from the site and disposed of by the Contractor at his own expense. Excavated material including pavement, base, rock and subgrade soils, shall be removed from the job site at the end of the workday. Failure to do so will result in the CITY removing material at the Contractor's expense. Cost shall be calculated at actual cost for labor and equipment plus administrative charges.

Full compensation for conforming to the requirements in this article shall be considered as included in the prices bid for the various contract items of work involved and no additional compensation will be allowed therefor.

ARTICLE 11.05 STORAGE OF MATERIALS: The Contractor shall at all times carefully and properly protect all materials of every description both before and after being used in the work and provide any enclosing or special protection from the weather as deemed necessary by the Engineer.

Full compensation for conforming to the requirements in this article shall be considered as included in the prices bid for the various contract items of work involved and no additional compensation will be allowed therefor.

ARTICLE 11.06 SOLID WASTE COLLECTION: If collection of solid waste shall occur during street construction, the Contractor shall assist the solid waste collection contractor in accessing containers for his collection of solid waste.

Full compensation for conforming to the requirements in this article shall be considered as included in the prices bid for the various contract items of work involved and no additional compensation will be allowed therefor.

ARTICLE 11.07 APPURTENANT WORK: All items in the proposal form are considered as complete in place including all incidental and appurtenant work and materials necessary for the satisfactory completion of the same.

Full compensation for conforming to the requirements in this article shall be considered as included in the prices bid for the various contract items of work involved and no additional compensation will be allowed therefor.

**ARTICLE 11.08 STORAGE YARD:** The Contractor shall at his expense provide a storage yard for his equipment, tools, and materials to be stored. Location of storage yard shall be approved by the Engineer. CITY streets are not to be used as a storage area/yard.

Full compensation for conforming to the requirements in this article shall be considered as included in the prices bid for the various contract items of work involved and no additional compensation will be allowed therefor.

**ARTICLE 11.09 PUBLIC UTILITIES:** It is the Contractor's responsibility to notify Underground Service Alert (USA) to locate facilities prior to beginning the work. In addition, the Contractor shall locate service laterals that may be affected by the work and take measures to protect all utilities and service laterals in the streets and parkways.

The Contractor shall determine for himself the exact location of all public and private utilities, facilities or substructures, which are not shown on the plans. In the event any utility, facility or substructure is disturbed or damaged, whether in its original or relocated position, the Contractor shall immediately cause repairs to be made to the satisfaction of the owner at no cost to the CITY.

The Contractor shall notify the utility companies at least forty-eight (48) hours prior to construction.

AT&T	YVETTE GAROFANO	(714) 618-9146
CALIFORNIA DOMESTIC WATER COMPANY	CHE VENEGAS	(562) 947-3811
CHEVRON USA	DAVE ZERLER	(310) 669-4014
CITY OF LA HABRA PARKS DEPT	DAVID VILLALBA	(562) 383-4170
CITY OF LA HABRA SEWER AND WATER DEPT	BRIAN JONES	(562) 383-4170
COMCAST CABLE COMPANY		(800) 501-5738
CRIMSON PIPELINE	APRIL HARVEY	(562) 285-4195
CR&R (WASTE HAULER)		(714) 372-8209
FRONTIER COMMUNICATIONS	ARIEL FATALA	(714) 375-6717
KINDER MORGAN	DON QUINN	(714) 560-4400
LA HABRA HEIGHTS WATER COMPANY		(562) 697-6769
METROPOLITAN WATER DISTRICT	MATT PARRY	(714) 577-5084
MOBIL OIL	RUTH CRONIN-FRUITT	(310) 212-1761
ORANGE COUNTY SANITATION DISTRICT	DANIEL LEE	(714) 593-7176
PLAINS ALL AMERICAN PIPELINE	JOE MATTEO	(562) 728-2368
SO CAL EDISON	JIMMY PARKIN	(714) 578-3434
SO CAL GAS	JASON MORTON	(213) 312-5735
SHELL PIPE COMPANY	MALDONADO	(310) 816-2063
SPECTRUM	DOMINIC HERNANDEZ	(714) 287-9385
SUBURBAN WATER SYSTEMS	TOM MEDINA	(562) 755-5015
TORRANCE LOGISTICS COMPANY	TERI A. SHINDE	(310) 212-1794

UNOCAL	ARNA ADAMS	(213) 864-5663
WESCON C/O VINTAGE		
PRODUCTION	EMILIO RODRIGUEZ	(562) 665-9255
UNDERGROUND SERVICE ALERT		(800) 422-4133

Full compensation for conforming to the requirements in this article shall be considered as included in the prices bid for the various contract items of work involved and no additional compensation will be allowed therefor.

ARTICLE 11.10 RESTORATION OF IMPROVEMENTS: The Contractor shall restore the construction site per the Greenbook (SSPWC) Section 7-9. All damage done to existing facilities and improvements by the Contractor shall be repaired by him to the satisfaction of the Engineer. All paint marks shall be removed at the end of the project by using an approved blasting method.

Lawn areas disturbed by the construction area shall be graded smooth and level with the adjacent lawn. All dirt clumps greater than one inch in size shall be crumbled or removed and all stone or rock shall be removed. The disturbed area shall be replaced with sod of a variety similar to the adjacent lawn. Shrubs destroyed or removed shall be replaced in kind to the satisfaction of the adjacent property owner. Paved areas shall be restored in kind to the satisfaction of the adjacent property owner. All fences disturbed, damaged or removed shall be restored to the satisfaction of the Engineer. In areas of close quarters the Contractor shall excavate by hand. Facilities damaged by using power tools shall be replaced to the satisfaction of the adjacent property owner. Cement concrete sidewalks removed or damaged shall be saw-cut and removed to the nearest score mark and replaced in accordance with CITY Standard Detail R-14. Any other improvements disturbed shall be restored to its original conditions and to the satisfaction of the adjacent property owner. Sprinklers and irrigation lines disturbed by the construction operations shall be restored to their original condition or better to the satisfaction of the adjacent property owner and/or Engineer.

Full compensation for conforming to the requirements in this article shall be considered as included in the prices bid for the various contract items of work involved and no additional compensation will be allowed therefor.

ARTICLE 11.11 WASTE MANAGEMENT: The Contractor shall comply with the requirements of AB939 and City of La Habra Construction and Demolition Ordinance, and submit a Waste Management Plan for the approval of the Engineer.

Full compensation for conforming to the requirements in this article shall be considered as included in the prices bid for the various contract items of work involved and no additional compensation will be allowed therefor.

ARTICLE 11.12 BID SCHEDULE: The quantities and sizes of materials shown in the bid schedule are for bid purposes only. The actual quantities used for construction and payment purposes shall be measured and determined by the CITY.

ARTICLE 11.13 EARTHWORK: Earthwork shall conform to the requirements of Section 300, "Earthwork" of the Standard Specifications and shall include all clearing and grubbing, demolition, saw-cut, excavation, grading, removal, disposal, backfilling or any other work necessary to prepare the sub-grade for construction of improvements.

Subdivision 11.13.1 Clearing and Grubbing: Clearing and grubbing shall conform to the applicable portions of Section 300, "Earthwork" of the Standard Specifications. All PCC and asphalt concrete to be removed shall be sawcut as needed to provide straight clean joints.

The tasks included as part of clearing and grubbing include the following:

1. Removal and restoration, replacement or relocation of fences, planters, foundations, walls, vegetation and irrigations systems not included as part of other bid items.
2. Protection of existing utilities, trees, fences, walls, signs and other facilities within the construction zone, except those directed to be removed or relocated.
3. Root pruning of tree roots and their disposal in areas where roots are causing lifting of existing concrete improvements. Work is to be as advised by the City Arborist.

Full compensation for conforming to the requirements in this article shall be considered as included in the prices bid for the various contract items of work involved and no additional compensation will be allowed therefor.

ARTICLE 11.14 TRENCHING: (Public Contracts Code §7104) If the herein public works contract involves digging trenches or other excavations that extend deeper than four feet below the surface the Contractor shall promptly, and before the following conditions are disturbed, notify the local public entity, in writing, of any:

- (1) Material that the Contractor believes may be material that is hazardous waste, as defined in Section 25117 of the Health and Safety Code, that is required to be removed to a Class I, Class II, or Class III disposal site in accordance with provisions of existing law.
- (2) Subsurface or latent physical conditions at the site differing from those indicated by information about the site made available to bidders prior to the deadline for submitting bids.
- (3) Unknown physical conditions at the site of any unusual nature, different materially from those ordinarily encountered and generally recognized as inherent in work of the character provided for in the contract.
- (4) The CITY shall promptly investigate the conditions, and if it finds that the conditions do materially so differ, or do involve hazardous waste, and cause a decrease or increase in the Contractor's cost of, or the time required for, performance of any part of the work shall issue a change order under the procedures described in the contract.
- (5) That in the event that a dispute arises between the CITY and the Contractor whether the conditions materially differ, or involve hazardous waste, or cause a decrease or increase in the Contractor's cost of, or time required for, performance of any part of the work, the Contractor shall not be excused from any scheduled completion date provided for by the contract, but shall proceed with all work to be performed under the contract. The Contractor shall retain any and all rights provided either by contract (Section 6.01.6 of the herein

Special Provisions) or by law which pertain to the resolution of disputes and protests between the contracting parties.

Trench excavation shall include, without classification, the removal of all materials of whatever nature encountered, including all asphalt or other obstructions of every nature that would interfere with the proper execution and completion of the work. The Contractor shall furnish, place and maintain all supports and shoring as set forth in the rules, orders and regulations of the Division of Industrial Safety of the State of California. The Contractor shall supply all pumping, ditching or other approved measure to effect the removal or exclusion of water, storm water and/or wastewater reaching the site of the work from any source so as to prevent damage to the work.

Full compensation for conforming to the requirements in this article, including but not limited to all saw cutting, trench excavation, moving and proper disposal of the excavated material, disposal fees, pumping, shoring, backfill, pipe zone material, backfill material, temporary AC pavement and related items shall be considered as included in the prices bid for the various contract items of work involved and no additional compensation will be allowed therefor.

ARTICLE 11.15 PUMPING: All excavations shall be kept free of water while concrete or pipe is being placed and until concrete has attained its initial set to eliminate any possible damage from such water. Any water accumulations in excavations from any source whatsoever shall be removed by the Contractor at his own expense. Wastewater shall be removed with a vacuum truck and disposed of offsite in such a manner that it will not cause any damage to public or private property or will not be a menace or inconvenience to the public. This article does not construe that groundwater is present. Field investigations have not been made to obtain water table depth.

Included as part of this article is removal and proper disposal of removed materials.

Full compensation for conforming to the requirements in this article shall be considered as included in the prices bid for the various contract items of work involved and no additional compensation will be allowed therefor.

ARTICLE 11.16 BACKFILLING AND COMPACTING: All excavations shall be backfilled to the level of the original ground surface unless otherwise shown on the plans or ordered by the Engineer.

Backfill around valve and valve box clusters shall be accomplished with sand (SE 30 or greater). The sand backfill shall be compacted by jetting. The trench, for a distance of five (5) feet each side of the valve box shall be filled with sand and compacted.

The trench shall be backfilled to a level six inches above the top of pipe with 1.5 sack sand-cement slurry. The remaining backfill shall be placed in horizontal layers per detail included herein. Each layer shall be moistened, tamped, puddled, rolled or otherwise compacted to maximum density per Greenbook requirements. The sand equivalent shall be certified by the Contractor.

Full compensation for conforming to the requirements in this article shall be considered as included in the prices bid for the various contract items of work involved and no additional compensation will be allowed therefor.

ARTICLE 11.17 SAND CEMENT SLURRY BACKFILL: 1.5 sack sand cement slurry backfill shall be placed at all tunnels and other locations that are impractical to achieve base compaction. Slurry shall be placed from top of bedding material to bottom of pavement surface.

Full compensation for conforming to the requirements in this article shall be considered as included in the prices bid for the various contract items of work involved and no additional compensation will be allowed therefor.

SECTION 12: BID ITEMS FOR ANNUAL ARTERIAL STREET REHABILITATION FY 19-20 :

ARTICLE 12.01: MOBILIZATION/DEMobilIZATION: Mobilization/Demobilization shall include all labor, work, and materials necessary to mobilize and demobilize forces, equipment, and materials; obtain bonding, insurance, permits, licenses; and other work as necessary to prepare for the construction of the work. Compensation for Mobilization shall not exceed **Five Percent (5%)** of the total bid amount.

Full compensation for complying with the work contained in this article for MOBILIZATION/DEMobilIZATION (BID ITEM 1) shall be considered included in the contract bid price per Lump Sum (LS), and no additional compensation will be allowed therefor. One half of the bid amount shall be paid upon beginning work and completion of at least ten percent (10%) of the other bid items. One half shall be paid upon completion of the work, punch-list items, and complete cleanup and restoration of the project site.

ARTICLE 12.02: TRAFFIC CONTROL, SAFETY AND CLEANUP: The Contractor is directed to Subdivision 11.01.3 "Public Convenience and Access" and Subdivision 11.01.4 "Public Notice" as part of this article. The Contractor shall be responsible for adequate barricading of the work area and controlling of traffic in the vicinity of the project as specified in Section 5-7 "Safety" in the Standard Specifications and these Special Provisions or as directed by the Engineer.

The Contractor's operations shall cause no unnecessary inconvenience. The access rights of the public shall be considered at all times. Unless otherwise authorized, traffic shall be permitted to pass through the Work, or an approved detour shall be provided.

NOTE: The Contractor is notified that this work is in the vicinity of, and along the route of, the following schools: **Las Lomas Elementary**. The Contractor shall take sufficient precautions to protect his work and the traveling public, especially during school hour commutes and events.

**Prior to construction, the Contractor shall submit to the Engineer for approval, a traffic control plan and a construction phasing plan.** The traffic control plan shall include, but not be limited to, location of all temporary signs, barriers, flashing arrow boards and proposed traffic flow diagrams. The information shall include the minimum requirements of the State of California

Manual of Uniform Traffic Control Devices (MUTCD), latest edition. The TCP shall be signed and stamped by either a Traffic Engineer (T.E.) or Professional Civil Engineer (P.E.), registered in the State of California and submitted by the Contractor to the CITY for approval.

The Contractor shall furnish at his expense and with no extra cost to the CITY such flagmen and guards as are necessary to give adequate warning to the public that roadway work is underway and of any dangerous conditions to be encountered. Flagmen shall perform their duties and be provided with equipment in accordance with current "Instructions to Flagmen" of the State of California, Division of Highways. The equipment shall be furnished, kept clean and in good repair by the Contractor at his own expense. The Contractor shall furnish, erect, maintain and regularly inspect barricades, lights, signs and other devices as are necessary to prevent accidents and avoid damage or injury to the public. These devices shall conform to the requirements set forth in the current "Manual of Warning Signs, Lights and Devices for Use in Performance of Work Upon Highways", issued by the State of California, Department of Transportation or State of California Manual of Uniform Traffic Control Devices (MUTCD), latest edition.

**All traffic control devices (delineators, signs, etc.) must be picked up at the end of the workday and stored off-site at an approved location. Traffic control devices may not be left overnight in the medians, at the curb, on sidewalks, etc. All graffiti on construction traffic control devices (delineators, signs, etc.) must be removed daily, or the signs be replaced.**

**Traffic control shall limit travel on only the specific work area for each day.**

**The roadway shall have at least one lane open in both directions at all times.**

**Parking shall be restricted only as needed for the specific work area for each day, and shall be reopened at the end of each work day. Parking restrictions may be from 7:00 AM to 4:00 PM on working days.**

**Through lanes and parking shall be restored by 4:00 PM each working day.**

**Trench plates shall be H20 load rated, skid resistant, and shall have traffic markings as needed to designate existing lane lines.**

**Before excavating through traffic loops, Contractor shall notify the CITY and have the signal placed on timed cycles. Loops shall be restored as soon as practicable.**

Closures and parking restrictions shall only be made for the amount of time necessary to complete construction activities. Areas that do not have active construction work shall be secured and reopened as directed by the Engineer. Extents of closures and parking restrictions shall be limited to areas as necessary for immediate construction activities. Contractor shall install temporary "No Parking" and "Tow Away" signs.

When necessary to provide vehicular or pedestrian crossings over the fresh pavement, the Engineer shall direct the Contractor to spread sufficient sand or rock dust on the affected area to eliminate

tracking or damage to the slurry. Sand or rock dust used for this purpose shall be at the Contractor's expense.

Safe and adequate pedestrian and vehicular access shall be provided and maintained to: fire hydrants; commercial and industrial establishments; churches, schools, and parking lots; service stations and motels; hospitals; police and fire stations; and establishments of similar nature. Access to these facilities shall be continuous and unobstructed unless otherwise approved by the Engineer.

Safe and adequate pedestrian zones and public transportation stops, as well as pedestrian crossings of the Work at intervals not exceeding 300 feet in each direction, shall be maintained unless otherwise approved by the Engineer.

Vehicular access to residential driveways shall be maintained to the property line except when necessary construction precludes such access for reasonable periods of time. If backfill has been completed to the extent that safe access may be provided, and the street is opened to local traffic, the Contractor shall immediately clear the street and driveways and provide and maintain access.

The Contractor shall provide temporary AC ramps where there are differences at removals and/or cold mills. Ramps shall be provided in advance of opening the lane to vehicular travel.

Grading operations, roadway excavation and fill construction shall be conducted by the Contractor in a manner to provide a reasonably satisfactory surface for traffic. When rough grading is completed, the roadbed surface shall be brought to a smooth, even condition satisfactory for traffic.

Unless otherwise authorized, work shall be performed in only one-half the roadway at one time. One half shall be kept open and unobstructed until the opposite side is ready for use. If one-half a street only is being improved, the other half shall be conditioned and maintained as a detour.

Contractor shall include the scheduling and required Traffic Control & Construction Phasing for all Slurry Seal work and shall provide a schedule to the Engineer for review prior to the Slurry Seal operations. The Contractor is to provide and distribute notices to the impacted properties seven (7) calendar days in advance of Crack and Slurry Seal operations. Contractor shall also post "No Parking" signage forty-eight (48) hours prior to the intended Crack and Slurry seal. The signage will provide the date and time that vehicles are prohibited from on street parking.

**Solar/battery powered Changeable Message Signs (CMS) shall be placed in advance of the project, at each end of the project segments, depending on sequencing, six (6) CMS may be required. The CITY shall direct the Contractor on the language of the message. The CMS shall be installed a minimum of one (1) month before the project starts, and the CITY has the right to make changes to the message at any time and at no additional cost to the CITY.**

The Contractor shall cooperate with the various parties involved in the delivery of mail, residents attempting to enter or exit, and the collection and removal of trash and garbage to maintain existing schedules for these services.

Full compensation for conforming to the requirements in this article TRAFFIC CONTROL, SAFETY AND CLEANUP (BID ITEM 2) shall be considered as included in the contract bid price per Lump Sum (LS), and shall include all labor, tools, materials and appurtenances necessary to complete the work and no additional compensation will be allowed therefor.

ARTICLE 12.03: CORNER RECORDS, CONSTRUCTION STAKING AND MONUMENT PERPETUATION: The Contractor shall provide all labor, tools, work, materials and appurtenances necessary to survey the work to conform to plan lines and limits, provide grades for drainage, establish pavement grades, match to existing conditions, and otherwise lay out the work as necessary for construction. The Contractor shall review and set all reference points, grades and elevations to the satisfaction of the Engineer prior to construction operations.

Pavement grades shall be provided as necessary for PCC construction, and to prepare the street for asphalt pavement operations. Grades shall provide for adequate drainage, match to existing slopes, gutters and other improvements, and provide a smooth profile. Nominal pavement grades shall be 2% from the pavement centerline to edge of gutter. In locations where gutter elevations differ on each side of the street, the slope shall be adjusted to provide adequate drainage, but shall not be less than 1% or more than 4%, and shall be approved by the Engineer.

Prior to the start of construction, the Contractor's licensed Land Surveyor or registered Civil Engineer licensed to practice land surveying in the State of California shall, in conformance with California State Law AB 1414, locate all monuments (whether or not of record), bench marks, and centerline ties within the construction zone, i.e., within one hundred feet of the construction activity. Additional ties to monuments shall be set when ties are missing (min. 4 ties per monument.) The Contractor's Licensed Surveyor or qualified Civil Engineer shall prepare and submit for review to the Engineer separate tie sheets and Corner Record sheets (monuments not of record shall have only tie sheets prepared). Tie sheets and Corner Records shall conform to the County Standards and the County Engineers' Association of California's "Guide to the Preparation of Records of Survey and Corner Records" document as provided by the County of Orange Land Surveyor's Office. Upon review by the Engineer, the Land Surveyor shall file the Corner Records with the County of Orange Land Surveyor's Office as required by law, and file Certified Corner Records with the City Engineer.

After construction and prior to final acceptance by the CITY of the construction project, the Contractor's land surveyor or qualified Civil Engineer shall re-survey all field monuments and centerline ties within the construction zone, prepare tie sheets and Corner Record sheets as indicated above, and file them with the City Engineer for review. After review by the City Engineer, the land surveyor shall file the Corner Records with the County of Orange Land Surveyor's Office as required by law, and file certified copies of the Corner Records with the City Engineer.

The Contractor shall not disturb any monuments, stakes or sign posts found on the line of the improvement until authorized by the Engineer. The Contractor shall bear the expense of resetting any monument, stakes or sign posts which may be disturbed without authorization from the Engineer. All survey monuments removed or altered as a result of construction shall be reset, Corner Records filed with the County of Orange Land Surveyor's Office, and approved final

Corner Records filed with the City Engineer. Centerline ties removed as a result of construction shall be reset and tie sheets filed with the City Engineer.

The Contractor is responsible to re-establish any survey monument that is disturbed, including monuments at the property line with no extra cost to the CITY to the satisfaction of the City Engineer.

The land surveyor shall provide a letter of certification for all monuments having four or more existing ties which are within 0.02 feet plus or minus of the original CITY tie sheet records. When several monuments or ties appear on one tie sheet and one of the ties has changed, the land surveyor shall re-measure all of the ties and re-file a new tie sheet with the CITY as required herein.

County of Orange permanent and temporary bench marks within the construction zone shall be located by survey, and the Contractor's Land Surveyor shall send a written notification of impending construction to the County of Orange Land Surveyor's Office two weeks prior to construction.

Lines and grades for the construction shall be the responsibility of the Contractor, with the following provisions:

All work under this contract shall be built in accordance with the lines and grades shown on the plans. Field survey for establishing these, and for the control of construction, shall be the responsibility of the Contractor. All such survey work including construction staking shall be done under the supervision of a California Licensed Land Surveyor or authorized Civil Engineer. Staking shall be done on all items ordinarily requiring grade and alignment, at intervals normally accepted by the agencies and trade involved.

The Contractor shall provide a copy of the office calculations and grade sheets to the Engineer. The Contractor shall be responsible for any errors in the finished work, and shall notify the Engineer, in writing, within twenty-four (24) hours, of any discrepancies, or design errors during the construction staking.

Contractor shall provide construction surveying for relocation of any conflicting utilities and provide a reasonable time window of opportunity to the utility owners to relocate their facilities after the survey is provided by the Contractor.

**Construction shall not begin until the Preliminary Corner Records are submitted to the City.**

**Project retention will not be released until all records are recorded with the County of Orange Land Surveyor's Office.**

Full compensation for conforming to the requirements in this article CORNER RECORDS, CONSTRUCTION STAKING AND MONUMENT PERPETUATION shall be considered as included in the contract bid price for the project, and shall include, but not be limited to, construction staking, location and/or relocation of conflicting utilities, locating survey monuments,

setting of survey monuments and center lines ties, preparing and filing centerline tie sheets and Corner Records, locating bench marks and notifying the County Surveyor's Office of same, professional office services and field calculation, and furnishing all labor, tools, materials, equipment and appurtenances necessary to complete the work and no additional compensation will be allowed therefor.

ARTICLE 12.04: STORM WATER BEST MANAGEMENT PRACTICES (BMPs): The Contractor shall comply with Section 3-12 "Work Site Maintenance" of the Standard Specifications for Public Works Construction. The Contractor shall not permit polluted water to enter a catch basin or drainage channel. Water pollution control work shall consist of constructing those facilities which may be shown on the Plans, specified elsewhere in these Special Provisions, required by the Standard Specifications, required by National Pollutant Discharge Elimination System (NPDES No. CAS000002) California General Permit for Storm Water Discharges Associated with Construction and Land Disturbance Activities Order No. 2009-0009-DWQ, or ordered by the Engineer. Said work is intended to provide prevention, control and abatement of water pollution to streams, waterways and other bodies of water.

In order to provide effective and continuous control of water pollution, it may be necessary for the Contractor to perform the contract work in small or multiple units on an out-of-phase schedule and with modified construction procedures. The Contractor shall provide temporary pollution control measures including, but not limited to, dikes, basins, ditches and the application of straw and seed which become necessary as a result of his operations. The Contractor shall coordinate water and pollution control work with all other work done on the contract.

Before starting any work on the project, the Contractor shall submit to the Engineer for acceptance a Water Pollution Control Plan (WPCP) for effective control of water pollution. Such WPCP shall show the schedule for the erosion control work included in the contract and for all water pollution control measures which the Contractor proposes to take in connection with construction of the project to minimize the effect of his operations upon adjacent streams and other bodies of water. The Contractor shall not perform any clearing and grubbing, or earthwork on the project, other than that specifically authorized in writing by the Engineer, until such WPCP has been accepted. The Contractor shall revise and bring up to date said WPCP at any time the Engineer makes written request for such revision.

The Engineer will notify the Contractor of the acceptance or rejection of any submitted or revised WPCP in not more than ten (10) days.

The CITY shall not be liable to the Contractor for failure to accept all or any portion of an originally submitted or revised WPCP, nor for any delays to the work due to the Contractor's failure to submit an acceptable WPCP.

The Contractor may request the Engineer to waive the requirement for submission of a written WPCP for control of water pollution when the nature of the Contractor's operation is such that erosion is not likely to occur. Waiver of this requirement will not relieve the Contractor from responsibility for compliance with the other provisions of this section. Waiver of the requirement for a written WPCP for control of water pollution will not preclude submittal of a written WPCP

at a later time if the Engineer deems it necessary because of the effect of the Contractor's operations.

Where erosion control damage will cause water pollution which is probably due to the nature of the material or the season of the year, the Contractor's operations shall be so scheduled that permanent erosion control features will be installed concurrently with or immediately following grading operations.

Compliance with the requirements of this article shall in no way relieve the Contractor from his responsibility to comply with the other provisions of the Contract, in particular, his responsibility for damage and for preservation of property.

All water pollution control work performed in accordance with the accepted WPCP which is not otherwise required under the contract and which is ordered by the Engineer will be paid for as follows:

- (1) Such water pollution control work which may be accomplished under the various contract items of work will be measured and paid for as provided for in these Special Provisions for the said items of work.
- (2) Such water pollution control work not covered by contract items will be paid for as extra work as provided for in Section 7-4 "Payment for Extra Work" of the Standard Specifications.

Except as otherwise provided in this Article 12.04, or in the Standard Specifications or elsewhere in these Special Provisions, full compensation for complying with the work contained in this article for STORM WATER BEST MANAGEMENT PRACTICES (BMPs) (BID ITEM 3) shall be considered included in the contract bid price per Lump Sum (LS), and no additional compensation will be allowed therefor.

ARTICLE 12.05: UNCLASSIFIED EXCAVATION AND DISPOSAL: This bid item shall include all labor, tools, materials and appurtenances necessary to complete the work necessary as part of this article which shall include, but not be limited to, sawcut, remove existing roadway structural asphalt concrete pavement, base aggregate, landscaping improvements and/or subgrade soils as necessary to prepare for placement of AC pavement per plans.

The removal of pumping soil, if encountered, shall also be included in unclassified excavation. Limits of additional removals due to pumping soil shall be specified by the Engineer.

Excavation, grading and backfill shall be done in conformance with the applicable portion of Section 300 "Earthwork" of the Standard Specifications and shall include any necessary excavation, and/or fill within the right-of-way, including imported material grading of area to finish subgrade ready for improvements, as shown on the plans or as directed by the Engineer.

The Contractor shall comply with Section 300-2.6, "Surplus Material", and shall furnish written consent from the owner of the property where it is intended to dispose of the surplus material.

When the exposed subgrade within 1.0 foot of the grading plane has a relative compaction of less than ninety percent (90%), the subgrade shall be scarified and recompactd in accordance with the provisions of the Standard Specifications and the relative compaction shall not be less than ninety percent (90%). All aggregate base material shall be compacted to 95 percent (95%) of relative maximum density. Tests for the compliance may be made by a representative of the CITY, at the expense of the CITY, using Test Method No. California 231. In the event the initial test fails, additional tests shall be made at the Contractor's expense.

Backfill material and placement shall conform to the applicable portions of Section 300 of the Standard Specifications.

Full compensation for conforming to the requirements in this article UNCLASSIFIED EXCAVATION AND DISPOSAL (BID ITEM 4) shall be considered as included in the contract bid price per Cubic Yard (CY), and shall include all labor, tools, materials and appurtenances necessary to complete the work and no additional compensation will be allowed therefor.

ARTICLE 12.06: CRACK SEALING: This bid item shall include all labor, tools, materials and appurtenances necessary to complete the work to crack seal the asphalt concrete pavement.

All AC pavement shall have all cracks cleaned and sealed either after milling and prior to AC overlay as follows:

All pavement cracks ¼ inch or wider shall be sealed with a hot applied rubberized asphalt sealant. In areas of question, the Engineer shall make the final determination as to which cracks shall be sealed. Crack sealant shall be Crafc0 Polyflex Sealant, Type 2 or 3, or approved equal, applied per manufacturer's instructions. Cracks less than ½" wide shall be cleaned by routing and blowing prior to applying the sealant. Cracks over ½" wide shall be cleaned by blowing operations prior to applying the sealant.

Cracks over 1" wide shall be cleaned by blowing operations, then filled by applying a tack coat and F-type AC mix compacted into place. The filled crack shall be sealed with an additional tack coat.

Care shall be taken to avoid excess sealant being applied to the existing pavement surface. The Contractor shall keep traffic off of areas receiving crack sealant until it has cured enough so that it will not be disturbed by traffic. Sealant shall not protrude above the adjacent pavement surface. Cracks shall be sealed at least four (4) days prior to overlay.

All cracks and joints containing vegetation shall be sprayed by a licensed applicator, with an approved herbicide, and removed prior to sealing with a rubberized crack sealant, as directed by the Engineer.

Full compensation for conforming to the requirements in this article CRACK SEALING (BID ITEM 5) shall be considered as included in the contract bid price per Lump Sum (LS), and shall

include all labor, tools, materials and appurtenances necessary to complete the work and no additional compensation will be allowed therefor.

ARTICLE 12.07: NOT USED

ARTICLE 12.08: NOT USED

ARTICLE 12.09: NOT USED

ARTICLE 12.10: COLD PLANE AND DISPOSED OF EXISTING AC PAVEMENT, 5' WIDE, This item shall include all labor, tools, equipment and appurtenances necessary to cold plane the edges of AC pavement to a depth of 1.5".

Full compensation for conforming to the requirements in this article COLD PLANE EXISTING AND DISPOSE AC PAVEMENT 1 1/2" DEPTH (INCLUDES REMOVAL AND DISPOSAL OF FILTER FABRIC) (BID ITEM 6) shall be considered as included in the contract bid price per Square Feet (SF), and shall include all labor, tools, materials and appurtenances necessary to complete the work, including costs for trucking and disposing of material, and no additional compensation will be allowed therefor

ARTICLE 12.11: RUBBERIZED ASPHALT CONCRETE

This item in the bid price per Tons includes all labor, tools, materials and appurtenances necessary to lay the Rubberized Asphalt as follows:

Asphalt concrete surface course shall be Asphalt Rubber Hot Mix, Type ARHM-GG-C, wet process, as specified in Section 203-11 and 302-9 of the Standard Specifications (last edition), per Typical Sections as shown on the plans, and shall conform to the following:

Paving asphalt used for asphalt-rubber shall be performance grade PG 64-16. Composition and Grading shall be per Section 203-11.3 of the Standard Specifications (latest edition). The Contractor shall submit a copy of the asphalt concrete mix design to the City or its designated laboratory a minimum of two weeks prior to the start of the construction.

The Contractor shall place the ARHM a maximum of 48 hours after the commencement of all edge grinding operations during any stage of the work for this project.

Apply SS-1H tack coat at a rate not to exceed one-tenth (1/10) gallon per square yard uniformly in one coat on all vertical joints of AC patching and P.C.C. surfaces and edges against which ARHM is to be placed. Diesel fuel shall not be used for cleaning purposes within the limits of this project.

All surfaces to be overlaid shall be cleaned by the use of a broom and a vacuum sweeper. The overlaid surface shall be free of water, dust, or foreign material before tack is applied. All raised

pavement markers shall be removed prior to the placement of any AHRM concrete overlay. Removal of all AC slurry seal residue from gutter lip should be completed prior to paving.

The Contractor shall utilize a paving machine equipped with an automatic adjusting screed, which is actuated by a 30-foot "ski", for the entire ARHM-GG overlay.

ARHM-GG shall be thoroughly compacted by rolling. The number of rollers necessary will be established in accordance with Section 302-5.6.1 of the Greenbook Specifications. All compacted ARHM-GG shall have a relative compaction of not less than 95 percent in accordance with Section 302-5.6.2 of the Greenbook Specifications.

Rolling along a joint shall be such that the widest part of the roller is on the hot side of the joint. Joint lines between successive runs shall be within 5 inches of lane lines or a minimum of 12 feet outside of the outer most lane line.

The Contractor shall provide for adequate quality control measures to insure that delivery of asphalt rubber shall be neither too slow nor too fast to prevent stopping of the paving operation and/or cooling of the asphalt rubber material. Material delivery scheduling and handling is critical to provide for optimum compaction opportunity and maximize ride quality performance.

**Rock dust blotter material shall be required immediately after the completions of the "finish rolling" and prior to opening to traffic to prevent bleeding and tracking of the asphalt rubber material.**

Rock dust blotter shall be per Section 200-1.2 of the Standard Specifications and shall be uniformly applied using a mechanical spreader, which distributes uniformly at a rate of approximately three pounds per square yard. Compaction rollers shall not be allowed on the rock dust covered pavement surfaces. All excess rock dust blotter shall be removed from the street at the end of each workday.

Full compensation for conforming to the requirement in this article INSTALL 1.5" TO 2.5" THICK ASPHALT RUBBER HOT MIX OVERLAY (ARHM-GG-C PG 64-16) (BID ITEM 7), shall be included in the contract unit price bid per ton (TON), based upon **certified weigh master tickets**. The unit price shall include all surface preparation, tack coat, rock dust blotter, labor, tools, equipment, materials, and incidentals required to complete the work. No additional compensation will be allowed.

ARTICLE 12.12: COLD MILL AND DISPOSE EXISTING AC PAVEMENT 1 1/2" DEPTH (INCLUDES REMOVAL AND DISPOSAL OF FILTER FABRIC): This bid item shall include all labor, tools, materials and appurtenances necessary to cold mill 1-1/2" depth of asphalt concrete pavement. Cold milling shall conform to Subsection 302-1 of the Standard Specifications and as indicated in these Special Provisions.

Existing asphalt concrete shall be milled at the locations and to the dimensions shown on Appendix "C" and in accordance with these Special Provisions. The milling of asphalt concrete pavement shall be performed by cold milling. The cold milling machine shall have a cutter head at least 30 inches wide and shall be operated so as not to produce fumes or smoke. The depth, width and

shape of the cut shall be as indicated on the typical cross sections or as directed by the Engineer. The final cut shall result in a uniform surface conforming to typical cross sections. The outside lines of the milled area shall be neat and uniform. The road surfacing to remain in place and other improvements in the public right-of-way or on private property shall not be damaged in any way. The Contractor shall use extreme caution when cold milling adjacent to the existing gutters, so as not to cause chipping and breakage of the concrete. The Contractor shall be responsible for the replacement of any and all concrete improvements damaged during the milling process.

The Contractor shall be responsible to locate and mark all facilities such as sewer manhole covers, telephone manhole covers, water valve covers, and catch basin covers, which, if struck, could damage the cold milling cutting drum and/or cutting teeth. The Contractor shall thoroughly inspect the work site in advance of the cold milling operation to minimize the risk of striking any unseen under surface object(s) and shall include in the price(s) bid for edge milling removal work an additional amount sufficient to cover the cost of damage related down time and the cost of repair of damage to said cold milling cutting drum and/or cutting teeth.

The material milled from the roadway surface, including material deposited in existing gutters or on the adjacent traveled way, shall be immediately removed from the site of the work and disposed of outside the road right-of-way. The removal crew shall follow within fifty (50) feet of the miller unless otherwise directed by the Engineer.

Residue from grinding shall not be permitted to flow or travel into gutters, onto adjacent street surfaces or parkways. All residue shall be immediately and completely removed by sweeping and properly disposed of. No washing of residue into drainage structures will be allowed. Cold milled materials shall become the property of the Contractor.

Both the perpendicular and parallel temporary taper transition may be achieved by over milling outside of the specified full depth mill limits or by using a full depth mill inside the specified full depth mill limits followed by a temporary asphalt concrete ramp. **The temporary asphalt concrete ramp must be removed prior to the actual asphalt concrete base course placement.** Adherence to all of the preceding temporary pavement surface maintenance requirements shall be absorbed into the unit costs for the various mills. Temporary ramping, where required by the Engineer for traffic control or other purposes, shall be considered included in this article and no additional compensation will be allowed.

**In areas where new asphalt pavement will join existing asphalt pavement, the Contractor shall sawcut edges to ensure a clean joint to existing asphalt pavement and as shown on the plans.**

Milled asphalt concrete pavement will be measured by the square yard. The quantity to be paid for will be the actual area of surface milled irrespective of the number of passes required.

Full compensation for conforming to the requirements in this article COLD MILL EXISTING AND DISPOSE AC PAVEMENT 1 1/2" DEPTH (INCLUDES REMOVAL AND DISPOSAL OF FILTER FABRIC) (BID ITEM 8) shall be considered as included in the contract bid price per

Square Yard (SY), and shall include all labor, tools, materials and appurtenances necessary to complete the work, including costs for trucking and disposing of material, and no additional compensation will be allowed therefor

ARTICLE 12.14: REMOVE AND RE-CONSTRUCT SPEED LUMPS PER DETAIL ON APPENDIX "D": This bid item shall include all labor, tools, materials and appurtenances necessary to remove existing and construct speed lumps. The Contractor shall saw cut and remove existing AC speed lumps, AC pavement, subgrade, and other in-place materials as necessary for construction; and construct AC speed lumps per detail as shown on appendix "D". This article shall include excavation, AC pavement, subgrade compaction, restoring of any disturbed irrigation/landscaping and striping of speed lump.

Striping for the speed lumps shall conform to the detail as shown on Appendix "D".

Full compensation for conforming to the requirements in this article REMOVE EXISTING AND CONSTRUCT SPEED LUMPS PER DETAIL ON APPENDIX "D" (BID ITEM 9 ) shall be considered as included in the contract bid price Each and shall include all labor, tools, materials and appurtenances necessary to complete the work and no additional compensation will be allowed therefor.

ARTICLE 12.15: SAWCUT & REMOVE EXISTING, CONSTRUCT 4" THICK CONCRETE SIDEWALK PER CITY STANDARD DETAIL NO. R-14: This bid item shall include all labor, tools, materials and appurtenances necessary to remove existing and construct new 4" thick concrete sidewalks over 3" sand per CITY Standard Detail No. R-14 complete in place. Portland cement concrete material shall be Portland Cement Concrete of type 520-C-2500. The Contractor shall saw-cut, excavate and remove existing in-place materials as necessary for construction, compact sub-grade, place and compact sand, construct new concrete sidewalk and proper disposal of all materials. New sidewalk finish shall match existing finish. Limits of construction shall be verified, measured and marked in the field by the Engineer prior to removing existing improvements.

The Contractor shall replace and repair any irrigation system, landscape/grass area damaged by his operation in all locations. In some locations, there may be tree roots that need to be removed for proper construction of the improvements. In these cases, the Contractor, at his own expenses, shall cut, remove, and properly dispose the roots per Engineer instructions and per all applicable laws, rules and regulations. All work necessary to remove and properly dispose of all removed material shall be at no extra cost to the CITY.

**Payment for root pruning within the limits of the sidewalk shall be included in the contract bid price.**

These pruning guidelines shall be followed by all persons or firms repairing or replacing damaged street, curbs, sidewalks, driveways or access ramps where the damage is attributable to the roots of the trees growing in the public right-of-way. At least two (2) days prior to any digging or excavating, DigAlert and the Parks Department at 562-383-4170, must be notified.

The Contractor shall remove the concrete at all tree root locations and notify the Parks Department forty-eight (48) hours in advance prior to performing root pruning or selective root removal.

One of the following methods or a combination of methods shall be used when pruning or root removal of tree roots:

Whenever possible, root pruning should only be performed on one side of a tree at a time, meaning on the sidewalk side or street side, but not on both, unless specifically authorized by the City Arborist.

- a. Root Pruning: The actual pruning of roots should be done using a trenching machine, which operates in a vertical motion only, with a root pruning attachment or some comparable piece of equipment, which can safely cut a narrow trench four (4) to six (6) inches wide.
- b. Selective Root Removal: Root larger than three (3) inches in diameter shall be horizontally trimmed or selectively removed. The utilization of a chain saw or other sawing tool shall be employed during this procedure. This procedure shall be overseen by the City Arborist.

All tree activity shall be conducted in a manner specified by ANSI Z133.1 – 2006 Safety Requirements & ANSI A300 (Part 1)-2001 Standard Practices (Pruning).

If the report from the City Arborist recommends the tree be removed because necessary root pruning would be detrimental to the structural integrity of the tree, the Contractor will coordinate with the CITY for removal by CITY resources.

The CITY reserves the right to delete any item or items of the Exhibit A - Bid Schedule and to increase or decrease any quantities in the Bid Schedule as the Engineer directs in exclusion of the Standard Specification for Public Works Construction “the Green Book”. This exclusion shall include, but not be limited to, “Section 3 – Changes In Work” of the Green Book. The twenty-five percent (25%) Green Book rule on quantities of total arithmetic dollar value shall not apply to this project. Unit prices shall continue to apply to the increased or decreased quantities for more and less than twenty-five percent (25%).

The Contractor shall re-establish any survey monument that is disturbed, including at the property lines, with no extra cost to CITY to the satisfaction of the Engineer. This item will be paid under the “Construction Staking and Monument Perpetuation” bid item.

No open excavations will be allowed over a weekend or holiday. The Contractor shall schedule work to accommodate this requirement. All concrete must be in place and forms removed prior to weekends and holidays.

Full compensation for conforming to the requirements in this article SAWCUT & REMOVE EXISTING, CONSTRUCT 4” THICK CONCRETE SIDEWALK PER CITY STANDARD DETAIL NO. R-14 (BID ITEM 10) shall be considered as included in the contract bid price per

Square Foot (SF), and shall include all labor, tools, materials and appurtenances necessary to complete the work and no additional compensation will be allowed therefor.

ARTICLE 12.16: SAWCUT & REMOVE EXISTING, CONSTRUCT 8" CONCRETE CURB & GUTTER OVER 6" CMB PER CITY STANDARD DETAIL NO. R-13, TYPE A 2-8 INCLUDING 1' WIDE FULL DEPTH AC SLOT: This bid item shall include all labor, materials, equipment, and work necessary to remove existing and construct new 8" concrete curb & gutter over 6" CMB per CITY Standard Detail No. R-13, Type A 2-8 with AC slot patch complete in place. The Contractor shall saw-cut; excavate and remove existing in-place materials as necessary and properly dispose of material, subgrade, and concrete for new construction; compact subgrade; place 6" CMB; and construct new 8" curb and gutter. New curb and gutter finish shall match existing type, curb height and finish and shall maintain water flow through the flowline. Limits of construction shall be verified, measured and marked in the field by the Engineer prior to removing existing improvements. The Contractor shall construct an asphalt concrete slot twelve inches wide with length that matches the length of the new curb and gutter. Adjustment of any existing pipe openings, removal of existing pavement and base/subgrade, and the installation of the AC slot patch shall be included in the contract bid price.

Portland cement concrete material shall be Portland Cement Concrete of Type 520-C-2500. Slot Patch should be Type C2 PG 64-10. CMB shall be per Section 200-2.2 of Greenbook but with the following modifications to Table 200-2.2.2:

3/4" Sieve (19.0 mm) shall have 100 percentage passing sieve

3/8" Sieve (19.0 mm) shall have 50-90 percentage passing sieve.

The Contractor shall replace and repair any irrigation system damaged by his operation in all locations. In some locations, there may be tree roots that need to be removed for proper construction of the improvements. In these cases, the Contractor, at his own expenses, shall cut, remove, and properly dispose the roots per Engineer instructions and per all applicable laws, rules and regulations. All work necessary to remove and properly dispose of all removed material shall be at no extra cost to the CITY.

**Payment for root pruning within the limits of the curb and gutter shall be included in the contract bid price.**

These pruning guidelines shall be followed by all persons or firms repairing or replacing damaged street, curbs, sidewalks, driveways, or access ramps where the damage is attributable to the roots of the trees growing in the public right-of-way. At least two (2) days prior to any digging or excavating, DigAlert and the Parks Department at 562-383-4170, must be notified.

The Contractor shall remove the concrete at all tree root locations and notify the Parks Department forty-eight (48) hours in advance prior to performing root pruning or selective root removal.

One of the following methods or a combination of methods shall be used when pruning or root removal of tree roots:

Whenever possible, root pruning should only be performed on one side of a tree at a time, meaning on the sidewalk side or street side, but not on both, unless specifically authorized by the City Arborist.

- a. Root Pruning: The actual pruning of roots should be done using a trenching machine, which operates in a vertical motion only, with a root pruning attachment or some comparable piece of equipment, which can safely cut a narrow trench four (4) to six (6) inches wide.
- b. Selective Root Removal: Root larger than three (3) inches in diameter shall be horizontally trimmed or selectively removed. The utilization of a chain saw or other sawing tool shall be employed during this procedure. This procedure shall be overseen by the City Arborist.

All tree activity shall be conducted in a manner specified by ANSI Z133.1 – 2006 Safety Requirements & ANSI A300 (Part 1)-2001 Standard Practices (Pruning).

If the report from the City Arborist recommends the tree be removed because necessary root pruning would be detrimental to the structural integrity of the tree, the Contractor will coordinate with the CITY for removal by CITY resources.

The Contractor shall paint the address of any house that is on a replaced curb with no extra cost to CITY to the satisfaction of the Engineer.

The CITY reserves the right to delete any item or items of the Exhibit A - Bid Schedule and to increase or decrease any quantities in the Bid Schedule as the Engineer directs in exclusion of the Standard Specification for Public Works Construction “the Green Book”. This exclusion shall include, but not be limited to, “Section 3 – Changes In Work” of the Green Book. The twenty-five percent (25%) Green Book rule on quantities of total arithmetic dollar value shall not apply to this project. Unit prices shall continue to apply to the increased or decreased quantities for more and less than twenty-five percent (25%).

No open excavations will be allowed over a weekend or holiday. The Contractor shall schedule work to accommodate this requirement. All concrete must be in place and forms removed prior to weekends and holidays.

Full compensation for conforming to the requirements in this article SAWCUT & REMOVE EXISTING, CONSTRUCT 8” CONCRETE CURB & GUTTER OVER 6” CMB PER CITY STANDARD DETAIL NO. R-13, TYPE A 2-8 INCLUDING WITH 1’ WIDE FULL DEPTH AC SLOT (BID ITEM 11) shall be considered as included in the contract bid price per Linear Foot (LF), and shall include all labor, tools, materials and appurtenances necessary to complete the work and no additional compensation will be allowed therefor.

ARTICLE 12.17: PCC CURB RAMP WITH DETECTABLE WARNING SURFACE OVER 3” SAND PER CALTRANS REVISED STANDARD PLAN RSP A88A, CASE B UNLESS OTHERWISE NOTED INCLUDING 1’ WIDE FULL DEPTH AC SLOT PATCH. This bid item shall include all labor, materials, equipment, and work necessary to remove existing and

construct new PCC curb ramp with detectable warning surface over 3" sand per Caltrans Revised Standard Plan RSP A88A, Case B, unless otherwise noted, complete in place. The Contractor shall saw-cut and remove existing PCC sidewalk, curb access ramps, curbs, gutter, spandrels, sand, subgrade and other in-place materials as necessary and properly dispose of material, subgrade, and concrete for new construction; compact subgrade; place 3" sand; and construct new PCC curb ramps with detectable warning surface where noted and as shown per detail drawings. New sidewalk shall match existing sidewalk finish and pattern as directed. **Bid item shall include curb ramp related sidewalk, retaining curb, curb, gutter, curb drain and 1' WIDE FULL DEPTH AC slot patch. Additionally, all related adjustments of pull boxes, pull box covers, protection or sign replacements within construction limits shall be considered as part of the ramp work and shall be included in the contract bid price.**

New curb ramp finish shall match existing type, curb height and finish and shall maintain water flow through the flowline. Limits of construction shall be verified, measured and marked in the field by the Engineer prior to removing existing improvements. The Contractor shall construct an asphalt concrete slot twelve inches wide with length that matches the length of the new curb and gutter. Adjustment of any existing pipe openings, removal of existing pavement and base/subgrade, and the installation of the AC slot patch shall be included in the contract bid price. For curb ramps that are joined to a spandrel, the Contractor shall sawcut a neat line 4" from the existing curb face.

Portland cement concrete material shall be Portland Cement Concrete of Type 520-C-2500. Slot Patch should be Type C2 PG 64-10. CMB shall be per Section 200-2.2 of Greenbook but with the following modifications to Table 200-2.2.2:

- 3/4" Sieve (19.0 mm) shall have 100 percentage passing sieve
- 3/8" Sieve (19.0 mm) shall have 50-90 percentage passing sieve.

Integral retaining curbs shall be constructed at the back of curb ramps and sidewalks as necessary to match existing landscape grades or to match existing grades at a wall. Integral curbs, curb and gutter, and sidewalk shall be constructed as shown on the plans.

Curb access ramps and sidewalks shall meet all ADA requirements, and shall not create impediments to access. Curb access ramps features, per standard plan, shall include:

- ramps not exceeding 7.5% slope
- flares not exceeding 9% slope
- turning space of 4'-2" by 4'-2" minimum area and maximum cross slopes of 1.5%
- bottom of ramps to be flush to gutters; The gutter width shall be 2' and not exceed 5% counter slope
- integral retaining curbs as necessary to match to existing landscape grades

**Detectable warning surface shall conform to the standard plans and shall be precast tactile tiles by Armor-Tile or approved equal, 3'x4' minimum, extending the full width of ramp. Edge of detectable warning tile is to be 6" to 8" from the flowline at the bottom of the ramp and parallel to adjacent to the street or tangent to the curb**

**return. The color of the detectable warning surface shall be YELLOW unless otherwise specified.**

The Contractor shall submit to the Engineer for review the following items:

- A. Product Data: Submit manufacturer's literature describing products, installation procedures and routine maintenance.
- B. Samples: Submit two tile samples of the kind proposed for use (minimum size 6" by 8").
- C. Materials Test Reports: Submit test reports from qualified independent testing laboratory indicating that materials proposed for use are in compliance with requirements and meet the properties indicated. All test reports shall be conducted on a cast-in-place tactile tile system as certified by a qualified independent testing laboratory.
- D. Maintenance Instructions: Submit copies of manufacturer's specified maintenance practices for each type of tactile tile and accessory as required.

The manufacturer shall provide a written five year warranty for prefabricated detectable warning surfaces, guaranteeing replacement when there is defect in the dome shape, color fastness, sound-on-cane acoustic quality, resilience, or attachment. The warranty period shall begin upon acceptance of the project.

The Contractor shall replace and repair any irrigation system damaged by his operation in all locations. In some locations, there may be tree roots that need to be removed for proper construction of the improvements. In these cases, the Contractor, at his own expenses, shall cut, remove, and properly dispose the roots per Engineer instructions and per all applicable laws, rules and regulations. All work necessary to remove and properly dispose of all removed material shall be at no extra cost to the CITY.

**Payment for root pruning within the limits of the curb ramp shall be included in the contract bid price.**

These pruning guidelines shall be followed by all persons or firms repairing or replacing damaged street, curbs, sidewalks, driveways, or access ramps where the damage is attributable to the roots of the trees growing in the public right-of-way. At least two (2) days prior to any digging or excavating, DigAlert and the Parks Department at 562-383-4170, must be notified.

The Contractor shall remove the concrete at all tree root locations and notify the Parks Department forty-eight (48) hours in advance prior to performing root pruning or selective root removal.

One of the following methods or a combination of methods shall be used when pruning or root removal of tree roots:

Whenever possible, root pruning should only be performed on one side of a tree at a time, meaning on the sidewalk side or street side, but not on both, unless specifically authorized by the City Arborist.

- c. Root Pruning: The actual pruning of roots should be done using a trenching machine, which operates in a vertical motion only, with a root pruning attachment or some comparable piece of equipment, which can safely cut a narrow trench four (4) to six (6) inches wide.
- d. Selective Root Removal: Root larger than three (3) inches in diameter shall be horizontally trimmed or selectively removed. The utilization of a chain saw or other sawing tool shall be employed during this procedure. This procedure shall be overseen by the City Arborist.

All tree activity shall be conducted in a manner specified by ANSI Z133.1 – 2006 Safety Requirements & ANSI A300 (Part 1)-2001 Standard Practices (Pruning).

If the report from the City Arborist recommends the tree be removed because necessary root pruning would be detrimental to the structural integrity of the tree, the Contractor will coordinate with the CITY for removal by CITY resources.

The CITY reserves the right to delete any item or items of the Exhibit A - Bid Schedule and to increase or decrease any quantities in the Bid Schedule as the Engineer directs in exclusion of the Standard Specification for Public Works Construction “the Green Book”. This exclusion shall include, but not be limited to, “Section 3 – Changes In Work” of the Green Book. The twenty-five percent (25%) Green Book rule on quantities of total arithmetic dollar value shall not apply to this project. Unit prices shall continue to apply to the increased or decreased quantities for more and less than twenty-five percent (25%).

No open excavations will be allowed over a weekend or holiday. The Contractor shall schedule work to accommodate this requirement. All concrete must be in place and forms removed prior to weekends and holidays.

The Curb Ramp limits shall be understood to be contained within a radial line from the BCR (beginning of curb return) to a radial line at ECR (end of curb return), or 5ft past the start of ramp transition and sidewalk join location to provide a sidewalk transition; whichever is greater.

Full compensation for conforming to the requirements in this article SAWCUT & REMOVE EXISTING, CONSTRUCT PCC CURB RAMP WITH DETECTABLE WARNING SURFACE OVER 3” SAND PER CALTRANS REVISED STANDARD PLAN RSP A88A, CASE B UNLESS OTHERWISE NOTED, INCLUDING 1’ WIDE FULL DEPTH AC OR PCC SLOT PATCH. (BID ITEM 12) shall be considered as included in the contract bid price per Each (EA), and shall include all labor, tools, materials and appurtenances necessary to complete the work and no additional compensation will be allowed therefor. The Contractor shall be responsible to remove and reconstruct curb access ramps at his own cost if the ramps are deemed non-compliant with project plans and specifications.

ARTICLE 12.18: SAWCUT & REMOVE EXISTING, CONSTRUCT 8” THICK CONCRETE CROSS GUTTER OVER 6” CMB PER CITY STANDARD DETAIL NO. R-6. WITHOUT DOWELS AND INCLUDING WITH 1’ WIDE FULL DEPTH AC SLOT: This bid item shall

include all labor, tools, materials and appurtenances necessary to complete the work necessary to remove existing and construct new 8" PCC cross gutter over 6" CMB per CITY Standard Detail No. R-6 without dowels, complete in place. The Contractor shall saw-cut, excavate and remove existing in-place materials as necessary and properly dispose of material, subgrade and concrete for new construction; compact subgrade; place and compact base; and construct new 8" thick PCC cross gutter as directed and as shown per detail drawings. New cross gutter shall join existing flow lines. The Contractor shall construct an asphalt concrete slot twelve inches wide with length that matches the length of the new cross gutter. New cross gutter finish shall match existing finish and flowline. Removal of existing pavement and base/subgrade, and the installation of the AC slot patch shall be included in the contract bid price. Limits of construction shall be verified, measured and marked in the field by the Engineer prior to removing existing improvements.

Portland cement concrete material shall be Portland Cement Concrete of Type 520-C-2500. Slot Patch should be Type C2 PG 64-10. CMB shall be per Section 200-2.2 of Greenbook but with the following modifications to Table 200-2.2.2:

- 3/4" Sieve (19.0 mm) shall have 100 percentage passing sieve
- 3/8" Sieve (19.0 mm) shall have 50-90 percentage passing sieve.

No open excavations will be allowed over a weekend or holiday. The Contractor shall schedule work to accommodate this requirement. All concrete must be in place and forms removed prior to weekends and holidays.

Full compensation for conforming to the requirements in this article SAWCUT & REMOVE EXISTING, CONSTRUCT 8" THICK CONCRETE CROSS GUTTER OVER 6" CMB PER CITY STANDARD DETAIL NO. R-6, WITHOUT DOWELS AND INCLUDING WITH 1' WIDE AC/PCC SLOT PATCH (BID ITEM 13 ) shall be considered as included in the contract bid price per Square Foot (SF), and shall include all labor, tools, materials and appurtenances necessary to complete the work and no additional compensation will be allowed therefor.

ARTICLE 12.19: SAWCUT & REMOVE EXISTING, CONSTRUCT 8" THICK CONCRETE SPANDREL OVER 6" CMB PER CITY STANDARD DETAIL NO. R-6 INCLUDING WITH 1' WIDE FULL DEPTH AC/PCC SLOT PATCH : This bid item shall include all labor, tools, materials and appurtenances necessary to complete the work necessary to remove existing and construct new spandrel, complete in place. The Contractor shall saw-cut, excavate and remove existing in-place materials as necessary and proper disposal of material, subgrade and concrete for new construction; compact subgrade; place and compact base; and construct new concrete spandrel per City Standard Detail No. R-6. The Contractor shall construct an asphalt concrete slot twelve inches wide with length that matches the length of the new concrete spandrel. New spandrel finish shall match existing finish and flowline. Removal of existing pavement and base/subgrade, and the installation of the AC slot patch shall be included in the contract bid price. Limits of construction shall be verified, measured and marked in the field by the Engineer prior to removing existing improvements.

Portland cement concrete material shall be Portland Cement Concrete of Type 520-C-2500. Slot Patch should be Type C2 PG 64-10. CMB shall be per Section 200-2.2 of Greenbook but with the following modifications to Table 200-2.2.2:

- 3/4" Sieve (19.0 mm) shall have 100 percentage passing sieve
- 3/8" Sieve (19.0 mm) shall have 50-90 percentage passing sieve.

The Contractor shall replace and repair any irrigation system damaged by his operation in all locations. In some locations, there may be tree roots that need to be removed for proper construction of the improvements. In these cases, the Contractor, at his own expenses, shall cut, remove, and properly dispose the roots per Engineer instructions and per all applicable laws, rules and regulations. All work necessary to remove and properly dispose of all removed material shall be at no extra cost to the CITY.

**Payment for root pruning within the limits of the concrete spandrel shall be included in the contract bid price.**

These pruning guidelines shall be followed by all persons or firms repairing or replacing damaged street, curbs, sidewalks, driveways, or access ramps where the damage is attributable to the roots of the trees growing in the public right-of-way. At least two (2) days prior to any digging or excavating, DigAlert and the Parks Department at 562-383-4170, must be notified.

The Contractor shall remove the concrete at all tree root locations and notify the Parks Department forty-eight (48) hours in advance prior to performing root pruning or selective root removal.

One of the following methods or a combination of methods shall be used when pruning or root removal of tree roots:

Whenever possible, root pruning should only be performed on one side of a tree at a time, meaning on the sidewalk side or street side, but not on both, unless specifically authorized by the City Arborist.

- a. Root Pruning: The actual pruning of roots should be done using a trenching machine, which operates in a vertical motion only, with a root pruning attachment or some comparable piece of equipment, which can safely cut a narrow trench four (4) to six (6) inches wide.
- b. Selective Root Removal: Root larger than three (3) inches in diameter shall be horizontally trimmed or selectively removed. The utilization of a chain saw or other sawing tool shall be employed during this procedure. This procedure shall be overseen by the City Arborist.

All tree activity shall be conducted in a manner specified by ANSI Z133.1 – 2006 Safety Requirements & ANSI A300 (Part 1)-2001 Standard Practices (Pruning).

If the report from the City Arborist recommends the tree be removed because necessary root pruning would be detrimental to the structural integrity of the tree, the Contractor will coordinate with the CITY for removal by CITY resources.

The CITY reserves the right to delete any item or items of the Exhibit A - Bid Schedule and to increase or decrease any quantities in the Bid Schedule as the Engineer directs in exclusion of the Standard Specification for Public Works Construction "the Green Book". This exclusion shall include, but not be limited to, "Section 3 – Changes In Work" of the Green Book. The twenty-five percent (25%) Green Book rule on quantities of total arithmetic dollar value shall not apply to this project. Unit prices shall continue to apply to the increased or decreased quantities for more and less than twenty-five percent (25%).

No open excavations will be allowed over a weekend or holiday. The Contractor shall schedule work to accommodate this requirement. All concrete must be in place and forms removed prior to weekends and holidays.

**Payment for curb and gutter within the limits of the concrete spandrel shall be included in the contract bid price.**

Full compensation for conforming to the requirements in this article SAWCUT & REMOVE EXISTING, CONSTRUCT 8" THICK PCC SPANDREL OVER 6" CMB PER CITY STANDARD DETAIL NO. R-6 INCLUDING WITH 1' WIDE AC/PCC SLOT PATCH (BID ITEM 14) shall be considered as included in the contract bid price per Square Foot (SF), and shall include all labor, tools, materials and appurtenances necessary to complete the work and no additional compensation will be allowed therefor.

ARTICLE 12.20: SAWCUT & REMOVE EXISTING, CONSTRUCT PCC RESIDENTIAL/COMMERCIAL DRIVEWAY APPROACH PER SPPWC STANDARD PLAN 110-2 INCLUDING THE 1' WIDE FULL DEPTH AC SLOT PATCH: This bid item shall include all labor, tools, materials and appurtenances necessary to remove existing and construct new concrete residential/commercial driveway approach per CITY Standard Detail SPPWC Standard Plan 110-2. The Contractor shall saw-cut, excavate and remove existing in-place materials as necessary and properly dispose of material, subgrade and concrete for new construction; compact subgrade; place and compact sand; and construct new driveway approach. The Contractor shall construct an asphalt concrete slot twelve inches wide with length that matches the length of the new driveway approach. New driveway approach finish shall match existing finish and shall maintain water flow through the flowline. Adjustment of any existing pipe openings, removal of existing pavement and base/subgrade, and the installation of the AC slot patch shall be included in the contract bid price. Limits of construction shall be verified, measured and marked in the field by the Engineer prior to removing existing improvements.

Portland cement concrete material shall be Portland Cement Concrete of Type 520-C-2500. Slot Patch should be Type C2 PG 64-10. CMB shall be per Section 200-2.2 of Greenbook but with the following modifications to Table 200-2.2.2:

- 3/4" Sieve (19.0 mm) shall have 100 percentage passing sieve
- 3/8" Sieve (19.0 mm) shall have 50-90 percentage passing sieve.

The Contractor shall replace and repair any irrigation system damaged by his operation in all locations. In some locations, there may be tree roots that need to be removed for proper construction of the improvements. In these cases, the Contractor, at his own expenses, shall cut, remove, and properly dispose the roots per Engineer instructions and per all applicable laws, rules

and regulations. All work necessary to remove and properly dispose of all removed material shall be at no extra cost to the CITY.

**Payment for root pruning within the limits of the driveway approach shall be included in the contract bid price.**

These pruning guidelines shall be followed by all persons or firms repairing or replacing damaged street, curbs, sidewalks, driveways, or access ramps where the damage is attributable to the roots of the trees growing in the public right-of-way. At least two (2) days prior to any digging or excavating, DigAlert and the Parks Department at 562-383-4170, must be notified.

The Contractor shall remove the concrete at all tree root locations and notify the Parks Department forty-eight (48) hours in advance prior to performing root pruning or selective root removal.

One of the following methods or a combination of methods shall be used when pruning or root removal of tree roots:

Whenever possible, root pruning should only be performed on one side of a tree at a time, meaning on the sidewalk side or street side, but not on both, unless specifically authorized by the City Arborist.

- a. **Root Pruning:** The actual pruning of roots should be done using a trenching machine, which operates in a vertical motion only, with a root pruning attachment or some comparable piece of equipment, which can safely cut a narrow trench four (4) to six (6) inches wide.
- b. **Selective Root Removal:** Root larger than three (3) inches in diameter shall be horizontally trimmed or selectively removed. The utilization of a chain saw or other sawing tool shall be employed during this procedure. This procedure shall be overseen by the City Arborist.

All tree activity shall be conducted in a manner specified by ANSI Z133.1 – 2006 Safety Requirements & ANSI A300 (Part 1)-2001 Standard Practices (Pruning).

If the report from the City Arborist recommends the tree be removed because necessary root pruning would be detrimental to the structural integrity of the tree, the Contractor will coordinate with the CITY for removal by CITY resources.

The Contractor shall paint the address of any house that is on a replaced curb with no extra cost to CITY to the satisfaction of the Engineer.

The CITY reserves the right to delete any item or items of the Exhibit A - Bid Schedule and to increase or decrease any quantities in the Bid Schedule as the Engineer directs in exclusion of the Standard Specification for Public Works Construction “the Green Book”. This exclusion shall include, but not be limited to, “Section 3 – Changes In Work” of the Green Book. The twenty-five percent (25%) Green Book rule on quantities of total arithmetic dollar value shall not apply

to this project. Unit prices shall continue to apply to the increased or decreased quantities for more and less than twenty-five percent (25%).

No open excavations will be allowed over a weekend or holiday. The Contractor shall schedule work to accommodate this requirement. All concrete must be in place and forms removed prior to weekends and holidays.

**Payment for curb and gutter within the limits of the driveway approach shall be included in the contract bid price.**

Full compensation for conforming to the requirements in this article SAWCUT & REMOVE EXISTING, CONSTRUCT RESIDENTIAL/COMMERCIAL DRIVEWAY APPROACH PER CITY STANDARD DETAIL SPPWC STANDARD PLAN 110-2 INCLUDING WITH THE 1' WIDE AC SLOT PATCH (BID ITEM 15) shall be considered as included in the contract bid price per Square Foot (SF), and shall include all labor, tools, materials and appurtenances necessary to complete the work and no additional compensation will be allowed therefor.

ARTICLE 12.21: NOT USED

ARTICLE 12.22: TRAFFIC STRIPING, CROSSWALKS, CURB PAINTING, MARKINGS AND RAISED PAVEMENT MARKERS: This bid item shall include all labor, tools, materials and appurtenances necessary to install traffic striping, crosswalks, curb painting, markings and raised pavement markers. The Contractor shall document all existing striping and pavement markings, curb paint, curb addresses, and raised pavement markers for areas which will be removed during construction. Contractor shall lay out and install new striping and markings to replace existing striping and markings, including painted curb and curb addresses where such have been removed due to construction, and raised pavement markers, including the installation of blue reflective raised pavement markers at all fire hydrant locations.

The materials for traffic paint shall be from the listed waterborne paint conforming to the Caltrans Standard Specifications (latest edition), Section 84-2, and the applicable provisions of the Standard Specifications for Public Works Construction "Greenbook" (latest edition). Raised pavement markers shall conform to the Caltrans Standard Specifications (latest edition), Section 85, and the Caltrans Standard Plans (latest edition).

Striping and Markings shall be painted (two coats of paint with reflective beads), unless otherwise shown, and shall be placed per Caltrans Standard Specification Section 84: Traffic Stripes and Pavement Markings. Paint, beads, and raised pavement markers shall be approved by the Engineer. The work shall include surface preparation, layout, material placement, curing, protection, testing, traffic control and all other work necessary to install the striping and markings, curb paint and addresses, and raised pavement markers.

Glass beads shall be applied to pavement markings, crosswalks, and striping by a dispensing device developed for this purpose or other methods approved by the Engineer. Streets and surrounding areas are to be kept clean of excess beads.

The Contractor shall furnish the necessary control points for replacement of all striping and markings and shall be responsible for the completeness and accuracy thereof to the satisfaction of the Engineer. No striping or markings shall be installed until the layout has been specifically approved by the Engineer.

Spotting shall be completed prior to the installation of any striping and markings.

After completion of paving, the Contractor shall install two-way blue raised reflectors on the pavement two (2) feet from centerline of the street (hydrant side) aligned with each fire hydrant location per City requirements.

Full compensation for conforming to the requirements in this article TRAFFIC STRIPING, CROSSWALKS, "STOP" LEGEND, SPEED LIMIT "30 MPH" LEGEND, "SLOW SCHOOL XING AHEAD" LEGEND, "RAILROAD XING AHEAD" LEGEND, RAILROAD CROSSING LEGEND, "KEEP CLEAR" LEGEND, SPEED LUMP STRIPING, CURB PAINTING, MARKINGS AND RAISED PAVEMENT MARKERS (BID ITEM 16) shall be considered as included in the contract bid price per Lump Sum (LS), and shall include all labor, tools, materials and appurtenances necessary to complete the work and no additional compensation will be allowed therefor.

ARTICLE 12.23: TRAFFIC SIGNAL LOOP DETECTOR: This bid item shall include all labor, tools, materials and appurtenances necessary to install traffic signal loop detectors. The Contractor shall install Type E and Type F loops, as shown per plan and in accordance with Section 86 and 87 of the Standard Specifications and Caltrans Standard Plan No. ES-5A and ES-5B, except as modified or supplemented herein. Loop detectors shall have a 6' diameter. Head loops shall be bicycle compatible, Modified Type D.

Loop detector sealant shall consist of hot melt rubber asphalt sealant, in accordance with 86-1.02W, "Loop Detector Sealants," and 87-1.03V, "Detectors," of the Caltrans Standard Specifications.

**The Contractor shall coordinate with Caltrans as necessary for work within and adjacent to State highways, including obtaining a Caltrans Encroachment Dual Permit, and paying for Caltrans permit fees and inspection costs. All work necessary (including signal work, paving, BMPs, traffic control plan, and traffic control labor and equipment) to coordinate with Caltrans shall be incidental and included in the various project costs.**

**The Contractor shall include in his bid prices as an incidental cost an allowance for inspection fees in accordance with the Caltrans Permit (see attached permit for reference).**

Existing loop leads shall be disconnected at the termination pull boxes prior to construction operations. New loop detectors shall be spliced to existing DLC's.

#### **Maintain Traffic Signals**

Existing traffic signals or approved temporary replacements shall be kept in effective operation for the benefit of the traveling public during the process of the work, except when shutdown is

permitted, to allow for alterations of the system. The traffic signal shutdowns shall be limited to normal working hours or shall be as specified in the Special Provisions. The Contractor shall notify the Engineer prior to performing any work on existing systems.

The Contractor shall notify the Engineer and local traffic enforcement agency prior to any operational shutdown of a traffic signal.

All installation and maintenance of temporary traffic signals shall be the responsibility of the Contractor, and furnished and installed as required to maintain safe and acceptable traffic conditions.

**NO ADDITIONAL COMPENSATION WILL BE ALLOWED FOR ADDITIONAL MOVE-INS REQUIRED TO CONFORM WITH PHASING SEQUENCING.**

No additional compensation will be allowed for removal of concrete containing reinforcing or other steel.

Full compensation for conforming to the requirements in this article TRAFFIC SIGNAL LOOP DETECTOR (BID ITEM 17) shall be considered as included in the contract bid price per Each (EA), and shall include, but not be limited to, full compensation for obtaining required permits with fees, phasing, temporary traffic signals, removals, replacements and pavement restoration, all labor, tools, materials and appurtenances necessary to complete the work and no additional compensation will be allowed therefor.

ARTICLE 12.24: ADJUST WATER VALVES TO GRADE: This bid item shall include all labor, tools, materials and appurtenances necessary to adjust water valves to grade. The work shall include, but not be limited to, saw-cut, excavation, removal and proper disposal of removed material, as well as protection, removal or lowering of the water valve during demolition and preparation, setting the structure to grade, and forming pavement or other constructed work around the structure. The work may include replacement with a new structure or cover to be provided by others. The finished adjustment shall be flush to adjacent surfaces and of sufficient strength to support anticipated traffic. All utility adjustment work and safety requirements shall be coordinated with the appropriate utility agency. If a lid or cover is to be replaced, the Contractor shall coordinate said replacement with the appropriate utility agency.

The Contractor shall verify in the field, with the CITY Water Department, the actual quantity and locations of the water valve box and cover adjustments. The CITY Water Department will provide the Contractor with new utility covers, in lieu of existing damaged covers, to install and adjust to grade per CITY Standard Detail W-4.

The Contractor shall remove all debris from within valve sleeves. Additional adjustments shall be necessary to keep the valve lid level with the surrounding pavement as the pavement is lowered and raised during the construction process.

Full compensation for conforming to the requirements in this article ADJUST WATER VALVES TO GRADE (BID ITEM 18) shall be considered as included in the contract bid price per Each (EA), and shall include all labor, tools, materials and appurtenances necessary to complete the work and no additional compensation will be allowed therefor.

ARTICLE 12.25: ADJUST SEWER, STORM DRAIN MANHOLE COVERS TO GRADE: This bid item shall include all labor, tools, materials and appurtenances necessary to adjust sewer, storm drain, and water manhole covers and vault covers to grade (except for utility covers, boxes, lids, and other utility structures which are adjusted by others or are covered under item ADJUST WATER VALVES TO GRADE). The work shall include, but not be limited to, saw-cut, excavation, removal and proper disposal of removed material, as well as protection, removal or lowering of the utility structure during demolition and preparation, setting the structure to grade, and forming pavement or other constructed work around the structure. The work may include replacement with a new structure or cover to be provided by others. The finished adjustment shall be flush to adjacent surfaces and of sufficient strength to support anticipated traffic. All utility adjustment work and safety requirements shall be coordinated with the appropriate utility agency. Additional adjustments shall be necessary to keep the valve lid level with the surrounding pavement as the pavement is lowered and raised during the construction process.

Full compensation for conforming to the requirements in this article ADJUST SEWER, STORM DRAIN MANHOLE COVERS TO GRADE (BID ITEM 19) shall be considered as included in the contract bid price per Each (EA), and shall include all labor, tools, materials and appurtenances necessary to complete the work and no additional compensation will be allowed therefor.

ARTICLE 12.26: ADJUST WATER METER BOXES TO GRADE: This bid item shall include all labor, tools, materials and appurtenances necessary to adjust traffic signal pull box covers to grade (except for utility covers, boxes, lids, and other utility structures which are adjusted by others). The work shall include, but not be limited to, saw-cut, excavation, removal and proper disposal of removed material, as well as protection, removal or lowering of the utility structure during demolition and preparation, setting the structure to grade, and forming pavement or other constructed work around the structure. The work may include replacement with a new structure or cover to be provided by others. The finished adjustment shall be flush to adjacent surfaces.. All utility adjustment work and safety requirements shall be coordinated with the appropriate utility agency. Additional adjustments shall be necessary to keep the pull box lid level with the surrounding pavement as the pavement is lowered and raised during the construction process.

Full compensation for conforming to the requirements in this article ADJUST TRAFFIC SIGNAL PULL BOXES TO GRADE shall be considered as included in the contract bid price for the removal and replacement of the ramp per article 12.17 , and shall include all labor, tools, materials and appurtenances necessary to complete the work and no additional compensation will be allowed therefor.

ARTICLE 12.27: ADJUST WATER METER BOXES TO GRADE: This bid item shall include all labor, tools, materials and appurtenances necessary to water meter boxes to grade (except for utility covers, boxes, lids, and other utility structures which are adjusted by others or are covered under item ADJUST WATER VALVES TO GRADE). The work shall include, but not be limited to, saw-cut, excavation, removal and proper disposal of removed material, as well as protection, removal or lowering of the utility structure during demolition and preparation, setting the structure to grade, and forming pavement or other constructed work around the structure. The work may include replacement with a new structure or cover to be provided by others. The finished

adjustment shall be flush to adjacent surfaces and of sufficient strength to support anticipated traffic. All utility adjustment work and safety requirements shall be coordinated with the appropriate utility agency. Additional adjustments shall be necessary to keep the valve lid level with the surrounding pavement as the pavement is lowered and raised during the construction process.

Full compensation for conforming to the requirements in this article ADJUST WATER METER BOXES TO GRADE (BID ITEM 20) shall be considered as included in the contract bid price per Each (EA), and shall include all labor, tools, materials and appurtenances necessary to complete the work and no additional compensation will be allowed therefor.

ARTICLE 12.28: NOT USED

ARTICLE 12.29: SAWCUT & REMOVE EXISTING, CONSTRUCT 24" CONCRETE CURB & GUTTER OVER 6" CMB PER DETAIL A INCLUDING WITH 1' WIDE FULL DEPTH AC SLOT: This bid item shall include all labor, tools, materials and appurtenances necessary to remove existing driveway approach, apron, metal pipe, curb and gutter and construct new 24" concrete curb & gutter over 6" CMB per Detail A on Plan Sheet 8 with AC slot patch complete in place. The Contractor shall saw-cut and remove existing PCC curb and gutter, remove existing related metal pipe, asphalt, base subgrade, and other in-place materials as necessary and properly dispose of material, subgrade, and concrete for new construction; prepare and compact the subgrade; place and compact base; and construct new 24" curb and gutter where noted and as shown per detail drawings. New curb and gutter finish shall match existing type, gutter slope, gutter width, curb height and finish and shall maintain water flow through the flowline. Limits of construction shall be verified, measured and marked in the field by the Engineer prior to removing existing improvements. The Contractor shall construct an asphalt concrete slot twelve inches wide with length that matches the length of the new curb and gutter. Adjustment of any existing pipe openings, removal of existing pavement and base/subgrade, and the installation of the AC slot patch shall be included in the contract bid price.

Portland cement concrete material shall be Portland Cement Concrete of Type 520-C-2500. Slot Patch should be Type C2 PG 64-10. CMB shall be per Section 200-2.2 of Greenbook but with the following modifications to Table 200-2.2.2:

- 3/4" Sieve (19.0 mm) shall have 100 percentage passing sieve
- 3/8" Sieve (19.0 mm) shall have 50-90 percentage passing sieve.

**The work shall include protection of existing culvert.**

No open excavations will be allowed over a weekend or holiday. The Contractor shall schedule work to accommodate this requirement. All concrete must be in place and forms removed prior to weekends and holidays.

Full compensation for conforming to the requirements in this article SAWCUT & REMOVE EXISTING, CONSTRUCT 24" CONCRETE CURB & GUTTER OVER 6" CMB PER DETAIL

A INCLUDING WITH 1' WIDE FULL DEPTH AC SLOT (BID ITEM 21 ) shall be considered as included in the contract bid price per Square Foot (SF), and shall include all labor, tools, materials and appurtenances necessary to complete the work and no additional compensation will be allowed therefor. The Contractor shall paint the address of any house that is on a replaced curb with no extra cost to CITY to the satisfaction of the Engineer.

ARTICLE 12.30: GRIND TREE ROOTS AND REMOVE EXISTING TREE AND ROOTS: This item shall include all labor, tools, materials and appurtenances necessary to coordinate with City Arborist for and perform the following work:

- a. Grind interfering portions of tree roots

Notify the City Parks Department at 562-383-4170 fourteen days prior to performance of the above work. Work shall be coordinated and performed to that satisfaction of the City Arborist.

Full compensation for conforming to the requirements in this article GRIND TREE ROOTS shall be considered as included in the contract bid price for sidewalk/concrete repairs and shall include all labor, tools, materials and appurtenances necessary to complete the work and no additional compensation will be allowed therefor.

**SECTION D**

**PROPOSAL**

## PROPOSAL

City of La Habra  
Civic Center  
110 E. La Habra Blvd.  
La Habra, California 90631

Gentlemen:

The undersigned hereby proposes to perform all work for which a contract may be awarded him and to furnish any and all plant, labor, services, materials, tools, equipment, supplies, transportation, utilities, and all other items and facilities necessary therefor as provided in the Contract Documents, and to do everything required therein for the project specifically set forth in documents entitled:

### **ANNUAL ARTERIAL STREET REHABILITATION FY 19-20 CITY PROJECT NO. 5-R-19**

together with appurtenances thereto, all as set forth on the drawing and in the specifications and other Contract Documents; and, he further proposes and agrees that if this Proposal is accepted he will contract in the form and manner stipulated to perform all the work called for by drawings, specifications and other Contract Documents and to complete all such work in strict conformity therewith within the time limits set forth therein, and that he will accept as full payment therefor the prices set forth in the Bid Schedule forming a part hereof.

A \*(Cashier's Check) \*(Certified Check) \*(Bid Bond) properly made payable to City of La Habra hereinafter designated as the Owner for the sum of \_\_\_\_\_

\_\_\_\_\_ dollars (\$ \_\_\_\_\_),  
which amount is not less than ten percent (10%) of the total amount of this bid, is attached hereto and is given as a guarantee that the undersigned will execute the Agreement and furnish the required bonds if awarded the Contract; and, in case of failure to do so within the time provided the proceeds of said check shall be forfeited to the \*Owner/Sureties Liability to the Owner for forfeiture of the face amount of the Bond shall be considered as established.

(\* ) Delete inapplicable word or phrase.

It is understood and agreed that:

1. The undersigned has carefully examined all the Contract Documents which will form a part of the Contract;
2. The undersigned has, by investigation of the site of the work and otherwise, satisfied himself as to the nature and location of the work and has fully informed himself as to all conditions and matters which can in any way affect the work or the cost thereof;
3. The undersigned fully understands the scope of the work and has checked carefully all words and figures inserted in this proposal and he further understands that the Owner will in no way be responsible for any errors or omissions in the preparation of this proposal;
4. The undersigned will execute the Agreement and furnish the required Performance and Payment Bonds and proof of insurance coverage, within ten (10) days (not

including Saturdays, Sundays and holidays) after notice to him of acceptance of his bid by the Owner; and further, that this bid may not be withdrawn for a period of sixty (60) days after the date set for the opening thereof, unless otherwise required by law. If any bidder shall withdraw his bid within said period, the Contractor shall be liable under the provisions of the Bid Security or the Contract and his surety shall be liable under the Bid Bond, as the case may be;

5. The undersigned hereby certifies that this proposal is genuine and not sham or collusive or made in the interest or in behalf of any person not herein named and the undersigned has not directly or indirectly induced or solicited any other bidder to put in a sham bid or any other person, firm or corporation to refrain from bidding; the undersigned has not in any manner sought by collusion to secure for himself an advantage over any other bidder;
6. In conformance with current statutory requirements of Section 1860, et seq., of the Labor Code of the State of California, the undersigned confirms the following as his certification:

I am aware of the provisions of Section 3700 of the Labor Code which requires every employer to be insured against liability of worker's compensation or to undertake in accordance with the provisions before commencing the performance of the work of this contract.

NOW, in compliance with the Notice Inviting Bids and all the provisions hereinbefore stipulated, the undersigned, with full cognizance thereof, hereby proposes to perform the entire work for the prices set forth in the attached Bid Schedule upon which award of the Contract is made.

Date: \_\_\_\_\_, 2022

Bidder \_\_\_\_\_

By \_\_\_\_\_

Title \_\_\_\_\_

Bidder's Post Office Address:

\_\_\_\_\_  
\_\_\_\_\_

Corporation organized under  
the laws of the State of \_\_\_\_\_

Names and addresses of all owners  
of the firm or names and titles of  
all officers of the corporation:

---

---

---

---

(corporate seal)

BIDDER'S INFORMATION

Contractor's License No. \_\_\_\_\_ Expiration Date \_\_\_\_\_

Classification of Contractor's License No. \_\_\_\_\_

Contractor \_\_\_\_\_  
(name of firm)

By \_\_\_\_\_  
(signature) (title)

Business Address: \_\_\_\_\_

\_\_\_\_\_

Phone ( ) \_\_\_\_\_

I/We certify that the information provided above is complete and true to the best of my/our knowledge.

\_\_\_\_\_  
Contractor Date

Contractor's DIR Public Works Registration No. \_\_\_\_\_

**EXHIBIT A**  
**BID SCHEDULE**

**ANNUAL ARTERIAL STREET REHABILITATION FY 19-20**  
**CITY PROJECT NO. 5-R-19**

ITEM	DESCRIPTION	QUANTITY	UNIT	UNIT PRICE	AMOUNT
1	MOBILIZATION (Not to Exceed Five Percent (5%) of the total bid amount)	1	LS		
2	TRAFFIC CONTROL, SAFETY AND CLEANUP	1	LS		
3	STORM WATER BEST MANAGEMENT PRACTICES (BMPs)	1	LS		
4	UNCLASSIFIED EXCAVATION AND DISPOSAL	120	CY		
5	CRACK SEALING	1	LS		
6	COLD PLANE (5' WIDE)	86000	SF		
7	CONSTRUCT 1.5"-2.5" RUBBERIZED AC OVERLAY ( AHRM-GG-C PG 64-16)	9440	TONS		
8	COLDMILL 1.5" AND DISPOSE EXISTING ASPALT INCLUDE THE REMOVAL OF ANY FABRIC	35100	SY		
9	REMOVE EXISTING AND CONSTRUCT SPEED LUMPS PER DETAIL SHOWN APPENDIX "D"	5	EA		
10	SAWCUT & REMOVE EXISTING, CONSTRUCT 4" THICK CONCRETE SIDEWALK OVER 3" SAND PER CITY STANDARD DETAIL NO. R-14	4722	SF		
11	SAWCUT & REMOVE EXISTING, CONSTRUCT 8" CONCRETE CURB & GUTTER OVER 6" CMB PER CITY STANDARD DETAIL NO. R-	637	LF		

	13, TYPE A 2-8 WITH AC SLOT PATCH				
12	SAWCUT & REMOVE CURB RAMP AND SIDEWALK, CONSTRUCT 4" PCC CURB RAMP WITH DETECTABLE WARNING SURFACE OVER 3" SAND PER CALTRANS REVISED STANDARD PLANS A88A (DATED JULY 2017), CASE B UNLESS OTHERWISE NOTED. CONSTRUCT 1' WIDE (8" AC / PCC DEEP LIFT) SLOT PATCH.	49	EA		
13	SAWCUT & REMOVE EXISTING, CONSTRUCT 8" PCC CROSS GUTTER OVER 6" CMB PER CITY STANDARD DETAIL NO. R-6, WITHOUT DOWELS, WITH AC SLOT PATCH	740	SF		
14	SAWCUT & REMOVE EXISTING, CONSTRUCT 8" PCC SPANDREL OVER 6" CMB PER CITY STANDARD DETAIL NO. R-6, INCLUDE FULL DEPTH AC SLOT PATCH	2156	SF		
15	SAWCUT & REMOVE EXISTING, CONSTRUCT 5" THICK PCC DRIVEWAY APPROACH (INCLUDING CURB AND GUTTER) PER SPPWC STANDARD PLAN 110-2, WITH AC SLOT TRENCH	2195	SF		
16	INSTALL TRAFFIC STRIPING, CROSSWALKS, CURB PAINTING, MARKINGS AND RAISED PAVEMENT MARKERS	1	LS		
17	TRAFFIC SIGNAL LOOP DETECTORS	45	EA		

18	ADJUST WATER VALVES TO GRADE	146	EA		
19	ADJUST SEWER, STORM DRAIN MANHOLE COVERS TO GRADE	101	EA		
20	ADJUST WATER METER BOX TO GRADE	2	EA		
21	SAWCUT & REMOVE EXISTING, CONSTRUCT 24" CONCRETE GUTTER IN FRONT OF DRIVEWAY OVER 6" CMB PER CITY STD WITH AC SLOT PATCH	200	LF		

TOTAL BID PRICE FOR BID SCHEDULE IN FIGURES: \$ \_\_\_\_\_

TOTAL BID PRICE FOR BID SCHEDULE IN WORDS: \_\_\_\_\_

Note: All bid quantities are estimated and for bidding purposes only, it may be increased or decreased at the discretion of the CITY. The provisions of Sections 3-2.2.2 and 3-2.2.3 of the Greenbook governing increases or decreases in quantity of more than 25% shall not apply.

Note: Excavation is included in the various bid items.

Note: The TOTAL BID PRICE shall be used as the basis of bid in determining the low bid for this project.

\_\_\_\_\_  
CONTRACTOR

\_\_\_\_\_  
BY

\_\_\_\_\_  
TITLE

\_\_\_\_\_  
DATE

ACKNOWLEDGEMENT OF ADDENDA RECEIVED

The Bidder shall acknowledge the receipt of addenda by placing an "X" by each addendum received.

- Addendum No. 1 \_\_\_\_\_
- Addendum No. 2 \_\_\_\_\_
- Addendum No. 3 \_\_\_\_\_
- Addendum No. 4 \_\_\_\_\_
- Addendum No. 5 \_\_\_\_\_
- Addendum No. 6 \_\_\_\_\_
- Addendum No. 7 \_\_\_\_\_
- Addendum No. 8 \_\_\_\_\_

If an addendum or addenda have been issued by the CITY and is not noted above as being received by the Bidder, the Bid Proposal may be rejected.

REFERENCES

[Work similar in scope magnitude and degree of difficulty completed by Contractor within the past three (3) years.]

1. Name (Firm/Agency): \_\_\_\_\_  
Address: \_\_\_\_\_  
Contact Person: \_\_\_\_\_ Telephone No. \_\_\_\_\_  
Title of Project: \_\_\_\_\_  
Project Location: \_\_\_\_\_  
Date of Completion: \_\_\_\_\_ Contract Amount: \$ \_\_\_\_\_
2. Name (Firm/Agency): \_\_\_\_\_  
Address: \_\_\_\_\_  
Contact Person: \_\_\_\_\_ Telephone No. \_\_\_\_\_  
Title of Project: \_\_\_\_\_  
Project Location: \_\_\_\_\_  
Date of Completion: \_\_\_\_\_ Contract Amount: \$ \_\_\_\_\_
3. Name (Firm/Agency): \_\_\_\_\_  
Address: \_\_\_\_\_  
Contact Person: \_\_\_\_\_ Telephone No. \_\_\_\_\_  
Title of Project: \_\_\_\_\_  
Project Location: \_\_\_\_\_  
Date of Completion: \_\_\_\_\_ Contract Amount: \$ \_\_\_\_\_
4. Name (Firm/Agency): \_\_\_\_\_  
Address: \_\_\_\_\_  
Contact Person: \_\_\_\_\_ Telephone No. \_\_\_\_\_  
Title of Project: \_\_\_\_\_  
Project Location: \_\_\_\_\_  
Date of Completion: \_\_\_\_\_ Contract Amount: \$ \_\_\_\_\_

If Contractor has not performed work for the City of La Habra within the last five (5) years, list all work done within said five years (attach additional sheets if necessary). Note if work was done as subcontractor (include only subcontract amount):

Work Description & Contract Amount	Agency	Date Completed

Contractor's License No.: \_\_\_\_\_ Class: \_\_\_\_\_

a. Date first obtained: \_\_\_\_\_ Expiration: \_\_\_\_\_

b. Has License ever been suspended or revoked? \_\_\_\_\_

If yes, described when and why: \_\_\_\_\_

c. Any current claims against License or Bond? \_\_\_\_\_

If yes, describe claims: \_\_\_\_\_

Principals in Company (List all – attach additional sheets if necessary):

<u>NAME</u>	<u>TITLE</u>	<u>LICENSE NO.</u> (If Applicable)
_____	_____	_____
_____	_____	_____
_____	_____	_____

DBE BIDDER'S LIST

All bidders/proposers are requested to provide the following information for all DBE and non-DBE contractors or consultants who provided a proposal, bid, quote, or were contacted by the proposed prime. This information is also requested from the proposed prime contractor/consultant and should be submitted with their bid/proposal. The City of La Habra will use this information to maintain and update a "Bidders" List to assist in the overall annual DBE goal-setting process.

<b>Firm Name:</b> _____	<b>Phone:</b> _____
<b>Address:</b> _____	<b>Fax:</b> _____
<b>Contact Person:</b> _____	<b>No. of years in business:</b> _____
<b>Is the firm currently certified as a DBE under 49 CFR Part 26: YES: ___ NO: ___</b>	
<b>Type of work/services/materials provided by firm?</b> _____	
_____	
_____	
<b>What was your firm's Gross Annual receipts for last year?</b>	
<b>Less than \$1 Million</b>	
<b>Less than \$5 Million</b>	
<b>Less than \$10 Million</b>	
<b>Less than \$15 Million</b>	
<b>More than \$15 Million</b>	

This form can be duplicated if necessary to report all bidders (DBEs and non-DBEs) information.

VIOLATIONS OF FEDERAL, STATE, OR LOCAL LAWS

1. Has your firm or its officers been assessed any penalties by an agency for noncompliance or violations of Federal, State, or Local labor laws and/or business or licensing regulations within the past five (5) years relating to your construction projects?

Yes/No: \_\_\_\_\_ Federal/State: \_\_\_\_\_

If "yes", identify and describe, (including agency and status):

---

---

---

---

---

---

---

---

Have the penalties been paid? Yes/No: \_\_\_\_\_

2. Does your firm or its officers have any ongoing investigations by any public agency regarding violations of the State Labor Code, California Business and Professions Code or State Licensing Laws?

Yes/No: \_\_\_\_\_ Code/Laws: \_\_\_\_\_ Section/Article: \_\_\_\_\_

If "yes", identify and describe, (including agency and status):

---

---

---

---

---

---

---

---

DISQUALIFICATION OR DEBARMENT

Has your firm, any officer of your firm, or any employee who has a proprietary interest in your firm ever been disqualified, removed, or otherwise prevented from bidding on, performing work on, or completing a federal, state, or local project because of a violation of law or a safety regulation?

Yes/No: \_\_\_\_\_

If yes, provide the following information (if more than once, use separate sheets):

Date: \_\_\_\_\_ Entity: \_\_\_\_\_

Location: \_\_\_\_\_

Reason: \_\_\_\_\_

\_\_\_\_\_  
\_\_\_\_\_  
\_\_\_\_\_

Provide Status and any Supplemental Statement: \_\_\_\_\_

\_\_\_\_\_  
\_\_\_\_\_  
\_\_\_\_\_

Has your firm been reinstated by this entity?

Yes/No: \_\_\_\_\_

LIST OF SUBCONTRACTORS

**ANNUAL ARTERIAL STREET REHABILITATION FY 19-20  
CITY PROJECT NO. 5-R-19**

The bidder shall list below the name and the location of the place of business of each Subcontractor who will perform work or render services to the prime contractor in or about the construction of the work or improvement in excess of one-half of one percent (1/2%) of the prime contractor's total bid or ten thousand dollars (\$10,000.00) whichever is greater in accordance with the requirements of Section 4100 to 4133 inclusive of the public contracts code.

<u>Work to be Performed</u>	<u>License Number</u>	<u>Subcontractor and Address of Office, Mill or Shops</u>	<u>Percent of Total Contract</u>	<u>DBE</u>	
				<u>YES</u>	<u>NO</u>

Note: Do not list alternative subcontractors for the same work.

Contractor \_\_\_\_\_

BID SECURITY FORM

(Check to Accompany Bid)

(Note: The following form shall be used in case check accompanies bid.)

Accompanying this proposal is a \*(Certified) \*(Cashiers) check payable to the order of the City of La Habra, California, hereinafter referred to as "Owner", for

**ANNUAL ARTERIAL STREET REHABILITATION FY 19-20  
CITY PROJECT NO. 5-R-19**

In the amount of \$ \_\_\_\_\_ Dollars, this amount being ten percent (10%) of the total amount of the bid. The proceeds of this check shall become the property of said Owner provided this proposal shall be accepted by the said Owner through action if its legally constituted contracting authorities and the undersigned shall fail to execute a contract and furnish the required Performance and Payment Bonds and proof of insurance coverage within the stipulated time; otherwise, the check shall be returned to the undersigned. The proceeds of this check shall also become the property of the Owner if the undersigned shall withdraw his bid within the period of forty-five (45) days after the date set for the opening thereof unless otherwise required by law and notwithstanding the award of the Contract to another bidder.

\_\_\_\_\_  
\_\_\_\_\_  
Bidder

\*Delete the inapplicable word.

NOTE: If the bidder desires to use a bond instead of a check, the Bid Bond form on the following pages shall be executed. The sum of this bond shall be not less than ten percent (10%) of the total amount of the bid.

BID BOND

KNOW ALL MEN BY THESE PRESENTS:

That we \_\_\_\_\_ as principal and \_\_\_\_\_ as surety, are held and firmly bound unto the City of La Habra, California hereinafter referred to as "Owner", in the sum of \_\_\_\_\_ Dollars (\$ \_\_\_\_\_) to be paid to the said Owner, its successors and assigns for which payment well and truly to be made we bind ourselves, our heirs, executors, administrators, successors and assigns, jointly and severally, firmly by these presents.

THE CONDITION OF THIS OBLIGATION IS SUCH that if the certain proposal of the above bounden for the construction of Street Improvements as specifically set forth in documents entitled:

**ANNUAL ARTERIAL STREET REHABILITATION FY 19-20  
CITY PROJECT NO. 5-R-19**

all in accordance with the specifications and drawings on file at the offices of the City Clerk of the City of La Habra, California and is not withdrawn within the period of sixty (60) days after the date set for the opening of bids unless otherwise required by law and notwithstanding the award of the Contract to another bidder and that if said proposal is accepted by the Owner through action of its legally constituted contracting authorities and if the above bounden his heirs, executors, administrators, successors and assigns shall duly enter into and execute a contract for such construction and shall execute and deliver the required Performance and Payment Bonds and proof of insurance coverage within ten (10) days (not including Saturdays, Sundays and Holidays) after the date of notification by and from the said Owner that the said contract is ready for execution, then this obligation shall become null and void; otherwise, it shall be and remain in full force and virtue.

IN WITNESS WHEREOF, we hereunto set hands and seal this \_\_\_\_\_

day of \_\_\_\_\_, 2022.

\_\_\_\_\_  
\_\_\_\_\_  
\_\_\_\_\_

BIDDER

NOTE: The standard printed bond form of any bonding company acceptable to the Owner may be used in lieu of the foregoing approved sample bond form provided the security stipulations protecting the Owner are not in any way reduced by use of the Surety Company's printed standard form.

NON-COLLUSION AFFIDAVIT  
FOR

**ANNUAL ARTERIAL STREET REHABILITATION FY 19-20**  
**CITY PROJECT NO. 5-R-19**

(TO BE EXECUTED BY EACH AWARDEE OF A PRINCIPAL CONTRACT)

STATE OF CALIFORNIA    )  
                                  ) SS.  
                                  )

\_\_\_\_\_, being first duly sworn,  
deposes and says that he is \_\_\_\_\_  
(sole owner, partner, president, secretary, etc.)

of \_\_\_\_\_  
The party making the foregoing bid; that such bid is not made in the interest of or on behalf of any undisclosed person, partnership, company, association, organization or corporation; that such bid is genuine and not collusive or sham: that said bidder has not directly or indirectly induced or solicited any other bidder to put in a false or sham bid, and has not directly or indirectly colluded, conspired, connived, or agreed with any bidder or anyone else to put in a sham bid, nor that anyone shall refrain from bidding; that said bidder has not in any manner directly or indirectly sought by agreement, communication or conference with anyone to fix the bid price of said bidder or of any other bidder, nor to fix any overhead, profit cost element of such bid price nor of that of any other bidder nor to secure any advantage against the public body awarding the contract or anyone interested in the proposed contract; that all statements contained in such bid are true; and, further, that said bidder has not directly or indirectly, submitted his bid price or any breakdown thereof, nor the contents thereof, nor divulged information or data relative thereto, nor paid and will not pay any fee in connection therewith to any corporation, partnership, company, association, organization, bid depository, nor to any member of agent thereof nor to any other individual except to such person or persons as have a partnership or other financial interest with said bidder in his general business.

Signed: \_\_\_\_\_

Title: \_\_\_\_\_

Subscribed and sworn to before me

This \_\_\_\_\_ day of \_\_\_\_\_, 2022

\_\_\_\_\_  
SEAL OF NOTARY PUBLIC

**WORKER'S COMPENSATION CERTIFICATE**

(AS REQUIRED BY SECTION 1861  
OF THE CALIFORNIA LABOR CODE)

I am aware of the provisions of Section 3700 of the California Labor Code, which require every employer to be insured against liability for worker's compensation, or to undertake self-insurance in accordance with the provisions of said Code, and I will comply with such provisions before commencing the performance of the Work of this Contract.

Contractor \_\_\_\_\_

By \_\_\_\_\_

Title \_\_\_\_\_

### **Public Contract Code Section 10285.1 Statement**

In conformance with Public Contract Code Section 10285.1 (Chapter 376, Stats. 1985), the bidder hereby declares under penalty of perjury under the laws of the State of California that the bidder **has** \_\_\_\_, **has not** \_\_\_\_, been convicted within the preceding three years of any offenses referred to in that section, including any charge of fraud, bribery, collusion, conspiracy, or any other act in violation of any state or Federal antitrust law in connection with the bidding upon, award of, or performance of, any public works contract, as defined in Public Contract Code Section 1101, with any public entity, as defined in Public Contract Code Section 1100, including the Regents of the University of California or the Trustees of the California State University. The term "bidder" is understood to include any partner, member, officer, director, responsible managing officer, or responsible managing employee thereof, as referred to in Section 10285.1.

Note: The bidder must place a check mark after "has" or "has not" in one of the blank spaces provided. The above Statement is part of the Proposal. Signing this Proposal on the signature portion thereof shall also constitute signature of this Statement. Bidders are cautioned that making a false certification may subject the certifier to criminal prosecution.

### Public Contract Code Section 10162 Questionnaire

In conformance with Public Contract Code Section 10162, the Bidder shall complete, under penalty of perjury, the following questionnaire:

Has the bidder, any officer of the bidder, or any employee of the bidder who has a proprietary interest in the bidder, ever been disqualified, removed, or otherwise prevented from bidding on, or completing a federal, state, or local government project because of a violation of law or a safety regulation?

Yes \_\_\_\_\_ No \_\_\_\_\_

If the answer is yes, explain the circumstances in the following space.

### **Public Contract Code Section 10232 Statement**

In conformance with Public Contract Code Section 10232, the Contractor, hereby states under penalty of perjury, that no more than one final unappealable finding of contempt of court by a federal court has been issued against the Contractor within the immediately preceding two year period because of the Contractor's failure to comply with an order of a federal court which orders the Contractor to comply with an order of the National Labor Relations Board.

Note: The above Statement and Questionnaire are part of the Proposal. Signing this Proposal on the signature portion thereof shall also constitute signature of this Statement and Questionnaire.

Bidders are cautioned that making a false certification may subject the certifier to criminal prosecution.

**SECTION E**  
**AGREEMENT**

## SAMPLE AGREEMENT

This Agreement is made and entered into this \_\_\_\_ day of \_\_\_\_\_, 2022 by and between **THE CITY OF LA HABRA**, hereinafter referred to as the “**CITY**” and \_\_\_\_\_ hereinafter referred to as the “**CONTRACTOR**”.

### RECITALS

WHEREAS, the City requires CONSTRUCTION WORK: and,

WHEREAS, the **CONTRACTOR** is qualified and experienced to perform such work; and,

NOW, THEREFORE, **CITY** and **CONTRACTOR** for the considerations hereinafter set forth, mutually agree as follows:

### ARTICLE I SCOPE OF WORK: TERM

#### 1.1 General Scope of Work:

**CONTRACTOR** shall for the price bid, upon request from **CITY**, furnish at his /her own proper cost and expense all necessary labor, materials, equipment, methods, processes, implements, services, tools, supplies, transportation, utilities and all other items and facilities to perform the required work for the \_\_\_\_\_, (hereinafter “The Project”). The project shall be performed in accordance with the contract documents consisting of the Proposal, the Bid Sheets as “Exhibit A”, the Agreement, the Faithful Performance Bond, the Payment Bond, the Non Collusion Affidavit, the Standard Plans for the City of La Habra and the Standard Specifications for Public Works Construction latest edition and supplements thereto, together with all additions, any modifications or interpretations of any said documents are hereby incorporated in and made part of this Agreement as fully as if set forth herein.

#### 1.2 Term.

The term of this Agreement shall begin upon signing by both parties and continue until completion of the work and its final acceptance by the **CITY**; or, until such time as it is terminated pursuant to the provisions in Article V of this Agreement.

### ARTICLE II RESPONSIBILITIES OF CONTRACTOR

#### 2.1 Control and Payment of Subordinates.

**CITY** retains **CONTRACTOR** as an independent contractor and not an employee of the **CITY**. All personnel to be utilized by **CONTRACTOR** in the performance of this Agreement shall at all times be under **CONTRACTOR’S** exclusive direction and control. **CONTRACTOR** shall pay all wages, salaries, and other amounts due such personnel in connection with their

performance of the Project under this Agreement and as required by law. **CONTRACTOR** shall be responsible for all reports and obligations with respect to such personnel, including, but not limited to social security taxes, income tax withholding, unemployment insurance, and workers' compensation insurance.

## 2.2 Conformance to Applicable Requirements.

All work constructed by **CONTRACTOR** shall be subject to the inspection and approval of the **CITY**.

## 2.3 Standard of Care, Licenses.

**CONTRACTOR** shall perform the Work under this Agreement in a skillful and competent manner. **CONTRACTOR** shall be responsible to **CITY** for any errors in its performance of this Agreement. **CONTRACTOR** represents and warrants to **CITY** that it has all licenses, permits, qualifications and approvals of whatever nature that are legally required to practice and to perform the Project hereunder. **CONTRACTOR** further represents and warrants that it shall keep in effect all such licenses, permits, and other approvals during the term of this Agreement.

## 2.4 Project Representatives.

**CONTRACTOR** assigns \_\_\_\_\_ as its Project Representative who shall coordinate all phases of the Project. The Project Representative shall be available to **CITY** at all reasonable times. **CONTRACTOR** may appoint another person as Project Representative upon written notice to **CITY**. **Albert Mendoza, P.E., Deputy Director Public Works/ City Engineer** shall act as **CITY'S** Project Representative for purposes of this Agreement.

## 2.5 Accounting Records.

**CONTRACTOR** shall maintain complete and accurate records with respect to costs and expenses incurred in the performance of this Project. All such records shall be clearly identifiable as being associated with this Project. **CONTRACTOR** shall allow an authorized representative of **CITY**, during normal business hours, to examine, audit, and make transcripts of copies of such records. **CONTRACTOR** shall allow **CITY** to inspect all work, data, documents, proceedings, and activities related to this Agreement for a period of three (3) years from the date of final payment (or completion of work) under this Agreement.

## ARTICLE III COMPENSATION

### 3.1 Compensation.

Except as provided in this section, **CONTRACTOR** shall receive compensation for all Work completed under this Agreement at the rates set forth in the Bid Sheets attached hereto as "EXHIBIT A". Total compensation shall not exceed bid amount without written approval of

CITY'S Project Representative. [Extra work may be authorized as described below, and, if authorized, shall be compensated at the rates and manner set forth in this Agreement]. The CITY MANAGER may authorize extra work to fund unforeseen conditions up to the amount approved at the time of award by the City Council. Payment for additional work in excess of this amount requires prior City Council Authorization.

### 3.2 Payment of Compensation.

**CONTRACTOR** shall provide **CITY** an itemized monthly statement, which indicates work completed, to the Project by **CONTRACTOR** from the date of written notice to proceed, or the start of the subsequent billing periods, as appropriate, through the date of the statement. **CITY** shall make any payment due within forty-five (45) days after approval of the invoice by **CITY**; payment will be made for the approved amount of the invoice minus five (5) percent. The five (5) percent retained will be held until forty-five (45) days after final completion and acceptance of the contract work.

### 3.3 Extra Work.

At any time during the term of this Agreement, **CITY** may request that **CONTRACTOR** perform Extra Work. As used herein, "Extra Work" means any work which is determined by **CITY** to be necessary for the proper completion of the Project, but which the parties did not reasonably anticipate would be necessary at the execution of this Agreement. **CONTRACTOR** shall not perform Extra Work until receiving prior written authorization from **CITY'S** Project Representative.

### 3.4 Amendment of Scope of Work.

**CITY** shall have the right to amend the Scope of Work within the Agreement by written notification to the **CONTRACTOR**. In such event, the compensation and time of performance shall be subject to renegotiations upon written demand of either party to the Agreement. Failure of the **CONTRACTOR** to secure **CITY'S** written authorization for extra or changed work shall constitute a waiver of any and all right to adjustment in the contract price or time due, whether by way of compensation, restitution, quantum merit, etc. for work done without the appropriate **CITY** authorization.

### 3.5 Notices.

The City Engineer or his designee shall be the representative of **CITY** for purposes of this Agreement and may issue all consents, approvals, directives and agreements on behalf of the **CITY**, called for by this Agreement, except as otherwise expressly provided in this Agreement. \_\_\_\_\_ shall be the representative of **CONTRACTOR** for purposes of this Agreement and may issue all consents, approvals, directives and agreement on behalf of **CONTRACTOR**, called for by this Agreement, except as otherwise expressly provided in this Agreement.

All notices and written communications sent by one party to the other shall be personally delivered or sent by registered or certified U.S. Mail postage prepaid, return receipt requested to the following addresses indicated below:

IF TO CITY:            Albert Mendoza, P.E.  
Deputy Director of Public Works/City Engineer  
City of La Habra  
110 E. La Habra Blvd.,  
La Habra, CA. 90631

TO CONTRACTOR: \_\_\_\_\_  
\_\_\_\_\_  
\_\_\_\_\_  
\_\_\_\_\_

The effective date of any notice or written communications sent by one party to the other shall be the date received if by personal service, or 48 hours after deposit in the U.S. Mail as reflected by the official U.S. postmark.

3.6 Reimbursement for Expenses

**CONTRACTOR** shall not be reimbursed for any expenses unless prior written authorization is obtained from **CITY**.

ARTICLE IV  
INSURANCE

4.1 Insurance Requirements.

The **CITY** reserves the right to modify these requirements, including limits, based on the nature of the risk, prior experience, insurer, coverage, or other special circumstances. If the existing policies do not meet the Insurance Requirements set forth herein, **CONTRACTOR** agrees to amend, supplement or endorse the policies to do so.

Without limiting the indemnity provisions of the Contract, the **CONTRACTOR** shall procure and maintain in full force and effect during the term of the Contract, the following policies of insurance.

4.2 Minimum Scope of Insurance.

- (a) **Commercial General Liability (CGL)** which affords coverage at least as broad as Insurance Services Office "occurrence" form CG 00 01, including products and completed operations, property damage, bodily injury, and personal & advertising injury with limits no less than \$5,000,000 per occurrence. If a general aggregate limit applies, either the

general aggregate limit shall apply separately to this project/location or the general aggregate limit shall be twice the required occurrence limit.

**Products-Completed Operations:** CONTRACTOR shall procure and submit to City evidence of insurance for a period of at least ten (10) years from the time that all work under this Contract is completed.

- (b) **Automobile Liability Insurance** with coverage at least as broad as Insurance Services Office Form CA 0001 covering "Any Auto" (Symbol 1) with limit no less than \$5,000,000 each accident for bodily injury and property damage.
- (c) **Workers' Compensation** as required by the State of California with statutory limits, and Employer's Liability Insurance with a limit of not less than \$1,000,000 per accident for bodily injury or disease.
- (d) **Builder's Risk Insurance** for any property constructed on behalf of the City, to cover "all risk" of physical loss providing coverage for loss or damage from collapse, including collapse resulting from builder's design error. All property stored off-site or in transit must be covered. The value insured shall cover 100% of the completed Contract cost, including Boiler & Machinery and Soft Costs and shall be maintained until full acceptance of the Work. Proceeds payable under the above insurance shall be fully payable to the City as Loss Payee.
- (e) **CONTRACTOR'S Pollution Legal Liability Legal Liability and/or Asbestos Pollution Liability and/or Professional Liability** covering all of the CONTRACTOR'S operations to include onsite and offsite coverage for bodily injury (including death and mental anguish), property damage, non-owned disposal site liability, defense costs, cleanup costs, and pollution conditions that arise from or in connection with the transportation (including loading and unloading) by or on behalf of the CONTRACTOR, of any waste or waste materials off or away from the project site. Coverage shall be provided for both sudden and accidental and gradual and continuous pollution events with limits no less than \$5,000,000 each loss and \$10,000,000 in the aggregate. The policy shall not exclude any hazardous materials for which there is an exposure.
- (f) **Surety Bonds:** CONTRACTOR shall provide the following Surety Bonds:
  - (a) Bid Bond
  - (b) Performance Bond
  - (c) Payment Bond
  - (d) Maintenance Bond

(DETERMINE NEED FOR EACH OF ABOVE BONDS)

The Payment Bond and the Performance Bond shall be in a sum equal to the contract price. If the Performance Bond provides for a one-year warranty a separate Maintenance Bond is not necessary. If the warranty period specified in the contract is for longer than one year a Maintenance Bond equal to 10% of the contract price is required. Bonds shall be duly executed by a responsible corporate surety, authorized to issue such bonds in the State of California and secured through an authorized agent with an office in California.

If the **CONTRACTOR** maintains broader coverage and/or higher limits than the minimums shown above, the **CITY** requires and shall be entitled to the broader coverage and/or higher limits maintained by the **CONTRACTOR**.

4.3 Endorsements.

Insurance policies shall not be in compliance if they include any limiting provision or endorsement that has not been submitted to the **CITY** for approval. The insurance policies shall contain or be endorsed to contain, the following provisions:

(a) Commercial General Liability & CONTRACTORS Pollution Liability

(1) **Additional Insured:** The City, its elected officials, officers, employees, volunteers, boards, agents and representatives (REVIEW NAMED INSURED'S FOR YOUR CITY) shall be additional insureds with regard to liability and defense of suits or claims arising out of the work or operations performed by or on behalf of the **CONTRACTOR** including materials, parts or equipment furnished in connection with such work or operations. Additional Insured Endorsements shall not:

1. Be limited to "Ongoing Operations"
2. Exclude "Contractual Liability"
3. Restrict coverage to the "Sole" liability of **CONTRACTOR**
4. Exclude "Third-Party-Over Actions"
5. Contain any other exclusion contrary to the Contract

Additional Insured Endorsements shall be at least as broad as ISO Form(s) CG 20 10 11 85; or CG 2010 and CG 20 37.

(2) **Primary Insurance:** This insurance shall be primary and any other insurance whether primary, excess, umbrella or contingent insurance, including deductible, or self-insurance available to the insureds added by endorsement shall be in excess of and shall not contribute with this insurance. Coverage shall be at least as broad as ISO CG 20 01 04 13.

(b) Auto Liability

- (1) **Additional Insured:** The City, its elected officials, officers, employees, volunteers, boards, agents and representatives (REVIEW NAMED INSURED'S FOR YOUR CITY) shall be additional insureds with regard to liability and defense of suits or claims arising out of the work or operations performed by or on behalf of the **CONTRACTOR**.
- (2) **Primary Insurance:** This insurance shall be primary and any other insurance whether primary, excess, umbrella or contingent insurance, including deductible, or self-insurance available to the insureds added by endorsement shall be in excess of and shall not contribute with this insurance.

(c) Workers' Compensation

- (1) **Waiver of Subrogation:** A waiver of subrogation stating that the insurer waives all rights of subrogation against the indemnified parties.

4.4 Insurance Obligations of Contractor.

The Insurance obligations under this agreement shall be: (1) all the Insurance coverage and/or limits carried by or available to the **CONTRACTOR**; or (2) the minimum Insurance coverage requirements and/or limits shown in this agreement; whichever is greater. Any insurance proceeds in excess of or broader than the minimum required coverage and/or minimum required limits, which are applicable to a given loss, shall be available to the **CITY**. No representation is made that the minimum Insurance requirements of this agreement are sufficient to cover the obligations of the **CONTRACTOR** under this agreement.

4.5 Notice of Cancellation.

Required insurance policies shall not be cancelled or the coverage reduced until a thirty (30) day written notice of cancellation has been served upon the City except ten (10) days shall be allowed for non-payment of premium.

4.6 Waiver of Subrogation.

Required insurance coverages shall not prohibit **CONTRACTOR** from waiving the right of subrogation prior to a loss. **CONTRACTOR** shall waive all rights of subrogation against the indemnified parties and Policies shall contain or be endorsed to contain such a provision. This provision applies regardless of whether the City has received a waiver of subrogation endorsement from the insurer.

#### 4.7 Evidence of Insurance.

All policies, endorsements, certificates, and/or binders shall be subject to approval by the City as to form and content. These requirements are subject to amendment or waiver only if so approved in writing by the City. The City reserves the right to require complete, certified copies of all required insurance policies, including endorsements required by these specifications, at any time.

The certificates and endorsements for each insurance policy shall be signed by a person authorized by that insurer to bind coverage on its behalf. At least fifteen (15 days) prior to the expiration of any such policy, evidence of insurance showing that such insurance coverage has been renewed or extended shall be filed with the City. If such coverage is cancelled or reduced, **CONTRACTOR** shall, within ten (10) days after receipt of written notice of such cancellation or reduction of coverage, file with the City evidence of insurance showing that the required insurance has been reinstated or has been provided through another insurance company or companies.

#### 4.8 Deductible or Self-Insured Retention.

Any deductible or self-insured retention must be approved in writing by the City and shall protect the indemnified parties in the same manner and to the same extent as they would have been protected had the policy or policies not contained a deductible or self-insured retention. The City may require the **CONTRACTOR** to purchase coverage with a lower retention or provide proof of ability to pay losses and related investigations, claim administration and defense expenses within the retention.

#### 4.9 Contractual Liability.

The coverage provided shall apply to the obligations assumed by the **CONTRACTOR** under the indemnity provisions of this contract.

#### 4.10 Failure to Maintain Coverage.

**CONTRACTOR** agrees to suspend and cease all operations hereunder during such period of time as the required insurance coverage is not in effect and evidence of insurance has not been furnished to the **CITY**. The **CITY** shall have the right to withhold any payment due until **CONTRACTOR** has fully complied with the insurance provisions of this Contract.

In the event that the **CONTRACTOR'S** operations are suspended for failure to maintain required insurance coverage, the **CONTRACTOR** shall not be entitled to an extension of time for completion of the Work because of production lost during suspension.

#### 4.11 Acceptability of Insurers.

Each such policy shall be from a company or companies with a current A.M. Best's rating of no less than A:VII and authorized to do business in the State of California, or otherwise allowed

to place insurance through surplus line brokers under applicable provisions of the California Insurance Code or any federal law. Any other rating must be approved in writing by the City.

#### 4.12 Claims Made Policies.

If coverage, including for Construction Defect claims, is written on a claims-made basis, the retroactive date on such insurance and all subsequent insurance shall coincide or precede the effective date of the initial **CONTRACTOR'S** Contract with the **CITY** and continuous coverage shall be maintained or an extended reporting period shall be exercised for a period of at least ten (10) years from termination or expiration of this Contract.

#### 4.13 Insurance for Subcontractors.

**CONTRACTOR** shall be responsible for causing Subcontractors to purchase the same types and limits of insurance in compliance with the terms of this Contract/Agreement, including adding the **CITY** as an Additional Insured, providing Primary and Non-Contributory coverage and Waiver of Subrogation to the Subcontractor's policies. The Commercial General Liability Additional Insured Endorsement shall be on a form at least as broad as CG 20 38 04 13.

#### 4.14 Additional Insurance.

Further, **CONTRACTOR** shall obtain any additional kinds and amounts of insurance which, in its own judgment, may be necessary for the proper protection of any of its officers', employees', or authorized sub-contractors' own actions during the performance of this Agreement.

#### 4.15 Notice of Policy Changes.

Each insurance policy required by this clause shall be endorsed to state that coverage shall not be suspended, voided, canceled, reduced in coverage or in limits except after thirty (30) days prior written notice by certified mail, return receipt requested, has been given to **CITY**.

Unless **CONTRACTOR'S** insurer agrees to provide (30) days written notice of any changes or modifications to any policies as required by this clause, **CONTRACTOR** shall provide copies of all required policies or certificates of insurance as may be requested by **CITY** to establish that such policies have not been modified or reduced in coverage or in limits.

### ARTICLE V TERMINATION AND INDEMNIFICATION

#### 5.1 Notice of Termination.

**CITY** may terminate the whole or any part of this Agreement at any time and without cause by giving seven (7) days written notice to **CONTRACTOR** of such termination, and specifying the effective date thereof. **CONTRACTOR** shall discontinue all services affected by such termination within seven (7) days of receipt of such notice, unless otherwise instructed by **CITY** in writing. **CONTRACTOR** may not terminate this Agreement except for cause.

#### 5.1.1 Termination Without Cause.

If **CITY** terminates this Agreement without cause, **CITY** shall pay **CONTRACTOR** for services performed through the date of termination, upon receipt of written documentation of said services. Such payment shall include a pro-rated amount of profit, if applicable, but no amount shall be paid for anticipated profit on unperformed services.

#### 5.1.2 Termination for Cause.

Should **CONTRACTOR** default in the performance of any covenant, condition, or agreement contained in this Agreement and the default is not cured within thirty (30) days after written notice of the default is served on **CONTRACTOR** by **CITY** then **CITY**, in addition to any other remedies at law or equity, may terminate this Agreement. **CONTRACTOR** shall be compensated for services, which have been completed and accepted by **CITY**. **CONTRACTOR** shall be liable to **CITY** for any reasonable additional costs incurred to correct or cure unsatisfactory work performed by **CONTRACTOR** which, at **CITY'S** discretion, must be revised, in part or in whole, to complete the Project.

#### 5.2 Procurement of Similar Services.

In the event this Agreement is terminated as provided by this Article, with or without cause, in whole or in part, **CITY** may procure, any and all services as may be necessary to complete the Project.

#### 5.3 Work Product.

Upon termination of this Agreement, **CITY** may require **CONTRACTOR** to provide all finished or unfinished documents, data, studies, drawings, reports, etc., prepared by **CONTRACTOR** in performance of this Agreement.

#### 5.4 Indemnification and Hold Harmless.

**These Indemnification provisions are independent of and shall not in any way be limited by the Insurance Requirements of this Agreement. City approval of the Insurance contracts required by this Agreement does not in any way relieve the CONTRACTOR from liability under this section.**

Except as to the sole or active negligence or willful misconduct of the **CITY** and notwithstanding the existence of insurance coverage required of **CONTRACTOR** pursuant to this contract, **CONTRACTOR** shall save, keep defend, indemnify, hold free and harmless **CITY**, its officers, officials, employees, agents and volunteers from and against any and all damages to property or injuries to or death of any person or persons, and shall defend, indemnify, save and hold harmless **CITY**, its officers, officials, employees, agents and volunteers from any and all claims, demands, suits, actions or proceedings of any kind or nature, including, but not by way of limitation, all civil claims, workers' compensation claims, and all other claims resulting from or arising out of the acts, errors or omissions of **CONTRACTOR**, its employees and/or authorized subcontractors, whether intentional or negligent, in the performance of this Agreement.

**CITY** will notify **CONTRACTOR** of the receipt of any third party claim related to this contract within \_\_\_ business days of receipt. The City is entitled to recover its reasonable costs incurred in providing the notification. (Pubic Contracts Code Section 9201)

## ARTICLE VI GENERAL PROVISIONS

### 6.1 Entire Agreement.

This Agreement contains the entire Agreement of the parties with respect to the subject matter hereof, and supersedes all prior negotiations, understandings, or agreement whether verbal or written, concerning the same subject matter. Only by writing signed by both parties may modify this Agreement.

### 6.2 Successors and Assigns.

This Agreement shall be binding on the successors and assigns of the parties. This Agreement may not be sold, transferred or assigned by either party, or by operation of law, to any other person or persons or business entity, without the other party's written permission. Any such sale, transfer or assignment, or attempted sale, transfer or assignment without written permission, may be deemed by the other party to constitute a voluntary termination of this Agreement and this Agreement shall thereafter be deemed terminated and void.

### 6.3 Subcontracts.

**CONTRACTOR** shall not subcontract any portion of the work required by this Agreement without prior written approval of **CITY**. All approved subcontracts, if any, shall be accomplished by a written instrument. Such instrument shall contain an expressed assumption by the subcontractor of all conditions and terms and covenants contained in this Agreement.

6.4 Equal Opportunity Employment.

**CONTRACTOR** represents that it is an equal opportunity employer and shall not discriminate either directly or indirectly against an employee or applicant for employment with **CONTRACTOR** on the basis of race, color, religion, national origin, ancestry, sexual preference, sex or age. **CONTRACTOR** shall also take affirmative steps to ensure that applicants are employed and employees are treated during employment without regard to race, color, religion, national origin, ancestry, sexual preference, sex, age, or other prohibited grounds.

6.5 Attorney's Fees.

If either party commences a legal action against the other party arising out of or in connection with this Agreement, the prevailing party in such litigation shall be entitled to have and recover reasonable attorney's fees and costs of suits.

6.6 Governing Law.

This Agreement shall be governed by and construed with the laws of the State of California. Any Action to enforce the terms of this Agreement or for the breach thereof shall be brought and tried in the County of Orange.

6.7 Time of Essence.

Time is of the essence for each and every provision of this Agreement.

6.8 Right to Employ Other Contractors.

**CITY** reserves the right to employ other contractors in connection with this Project.

6.9 Covenant Against Contingent Fees.

The **CONTRACTOR** warrants that he has not employed or retained any company or person, other than a bona fide employee working with the **CONTRACTOR**, to solicit or secure this Agreement, and that he has not paid or agreed to pay any company or person, other than a bona fide employee, any fee, commission, percentage, brokerage fee, gift, or any other consideration, contingent upon or resulting from the award or making this Agreement. For breach or violation of this warranty, the **CITY** shall have the right to annul this Agreement without liability, or, in its discretion to deduct from the Agreement the price or consideration, or otherwise recover, the full amount of such fee, commission, percentage, brokerage fee, gift, or contingent fee.

6.10 Conflict of Interest.

**CONTRACTOR** covenants that it presently has no interest and shall not acquire any interest, direct or indirect, which would conflict in any manner or degree with the

performance of its services hereunder. **CONTRACTOR** further covenants that in the performance of this Agreement, no person having any such conflict of interest shall be employed by **CONTRACTOR**.

6.11 Statement of Economic Interest.

If **CITY** determines **CONTRACTOR** comes within the definition of **CONTRACTOR** under the Political Reform Act (Government Code §87100 et. seq.), **CONTRACTOR** shall complete and file and shall require any other person doing work under this Agreement, to complete and file a "Statement of Economic Interest" with the City Clerk of the **CITY** disclosing **CONTRACTOR** and/or such other person's financial interests.

6.12 No Waiver of Breach: Time.

No waiver of any provision of this Agreement shall be effective unless in writing and signed by a duly authorized representative of the party against whom enforcement of a waiver is sought referring expressly to this Paragraph. The waiver of any right or remedy in respect to any occurrence or event shall not be deemed a waiver of any right or remedy in respect to any other occurrence or event, nor shall any waiver constitute a continuing waiver.

6.13 Third Party Beneficiaries.

Nothing contained in this Agreement shall be construed to create and the parties do not intend to create any rights in third parties.

6.14 Taxes.

**CONTRACTOR** agrees to file tax returns and pay all applicable taxes on amounts paid pursuant to this Agreement and shall be solely liable and responsible to pay such taxes and other obligations, including, but not limited to, state and federal income and FICA taxes. **CONTRACTOR** agrees to indemnify and hold the **CITY** harmless from any liability which it may incur to the United States or to the State of California as a consequence of **CONTRACTOR'S** failure to pay, when due, all such taxes and obligations.

6.15 Compliance With Law.

**CONTRACTOR** shall comply with applicable federal, state and local laws, rules and regulations affecting the **CONTRACTOR** and his/her work hereunder.

6.16 Title to Documents.

Title to all plans, specifications, maps, estimates, reports, manuscripts, drawings, descriptions and other final work products that may be compiled by the **CONTRACTOR** under the Agreement shall be vested in the **CITY**, none of which shall be used in any manner whatsoever, by any person, firm, corporation, or agency without the expressed

written consent of the CITY. Basic survey notes and sketches, charts, computations, and other data prepared or obtained under the Agreement shall be made available, upon request, to the CITY without restriction or limitations on their use. CONTRACTOR may retain copies of the above described information but agrees not to disclose or discuss any information gathered, discussed or generated in any way through this Agreement without the written permission of CITY during the term of this Agreement or until ninety (90) days after receipt of final payment from CITY.

6.17 Validity.

The validity in whole or in part of any provision of this Agreement shall not void or affect the validity of any other provisions of this Agreement.

6.18 Headings.

Section and subsection headings are not to be considered part of this Agreement, are included solely for convenience, and are not intended to modify or explain or to be a full or accurate description of the content thereof.

6.19 Counterparts.

This Agreement may be executed in one or more counterparts by the parties hereto. All counterparts shall be construed together and shall constitute one agreement.

6.20 Corporate Authority.

The persons executing this Agreement on behalf of the Parties hereto warrant that they are duly authorized to execute this Agreement on behalf of said Parties and that by doing so, the Parties hereto are formally bound to the provision of this Agreement.

IN WITNESS WHEREOF, the parties hereto have caused this Agreement to be executed the date and year first above written.

**CITY OF LA HABRA**

**CONTRACTOR**

\_\_\_\_\_  
JIM SADRO  
CITY MANAGER

\_\_\_\_\_  
Name: \_\_\_\_\_

Title: \_\_\_\_\_

**ATTEST:**

\_\_\_\_\_  
LAURIE SWINDELL, CMC  
CITY CLERK

**COUNTER SIGNED:**

\_\_\_\_\_  
RICHARD D. JONES  
CITY ATTORNEY

**FAITHFUL PERFORMANCE BOND**

KNOW ALL MEN BY THESE PRESENTS:

That we, \_\_\_\_\_  
\_\_\_\_\_ hereinafter referred to as  
"Contractor", as principal, and \_\_\_\_\_  
\_\_\_\_\_ as surety, are held and firmly  
bound unto City of La Habra in the sum of \_\_\_\_\_

\_\_\_\_\_ Lawful money of the United States of America for the payment of which sum well and truly to be made we bind ourselves jointly and severally, firmly by these presents.

The condition of the foregoing obligation is such that WHEREAS, said Contract has been awarded and is about to enter into the annexed contract with City of La Habra for construction of Street Improvements as specifically set forth in the documents entitled:

**ANNUAL ARTERIAL STREET REHABILITATION FY 19-20  
CITY PROJECT NO. 5-R-19**

and is required under the terms of the Contract to give this bond in connection with the execution of said contract.

NOW, THEREFORE, if the said Contractor shall well and truly do and perform all of the covenants and obligations of said contract on his part to be done and performed at the times and in the manner specified herein, then this obligation shall be null and void, otherwise it shall be and remain in full force and effect.

PROVIDED, that any alterations in the work to be done or the materials to be furnished which may be made pursuant to the terms of said Contract shall not in any way release either the Contractor or the surety thereunder nor shall any extensions of time granted under the provisions of said Contract release either the Contractor or the surety, and notice of such alterations or extensions of the Contract is hereby waived by the surety.

WITNESS our hands this \_\_\_\_\_ day of \_\_\_\_\_, 2022.

\_\_\_\_\_  
Contractor

BY: \_\_\_\_\_

(Seal)

\_\_\_\_\_  
Title

APPROVED:

\_\_\_\_\_  
Surety

BY: \_\_\_\_\_

\_\_\_\_\_  
(Seal)

Mailing Address of Surety:

\_\_\_\_\_  
\_\_\_\_\_  
\_\_\_\_\_

\_\_\_\_\_  
Telephone Number of Surety

**PAYMENT BOND**

KNOW ALL MEN BY THESE PRESENTS:

That we, \_\_\_\_\_

\_\_\_\_\_ Hereinafter referred to as

“Contractor”, as principal, and \_\_\_\_\_

\_\_\_\_\_ as surety, are held and firmly

bound unto the City of La Habra, California in the sum of

\_\_\_\_\_  
\_\_\_\_\_

Lawful money of the United States of America for the payment of which sum well and truly to be made we bind ourselves jointly and severally, firmly by these presents.

The condition of the above obligation is such that:

WHEREAS, said Contractor has been awarded and is about to enter into the annexed Contract with said City of La Habra for the construction of Street Improvements as specifically set forth in documents entitled:

**ANNUAL ARTERIAL STREET REHABILITATION FY 19-20  
CITY PROJECT NO. 5-R-19**

And is required under the terms of the Contract to give this bond in connection with execution of said contract.

NOW, THEREFORE, if the said Contractor or any of his subcontractors fails to pay any of the persons named in Section 9100 of the Civil Code of the State of California or amounts due under the Unemployment Insurance Code with respect to work or labor performed by any such person for or about the performance of the aforementioned

Contract, said surety will pay the same in an amount not exceeding the sum specified in this bond and in case suit is brought upon this bond a reasonable attorney’s fee to be fixed by the Court. This bond shall inure to the benefit of any and all persons named in Section 9100 of the Civil Code of the State of California so as to give a right of action to such persons or their assigns in any suit brought upon this bond. This bond shall be subject to and include all of the provisions of Title 3 of Part 6 of Division 4 of the Civil Code of California relating to Payment Bond for Public Works, including but not confined to, Civil Code Section 9550-9566, inclusive.

PROVIDED, that any alterations in the work to be done or the material to be furnished which may be made pursuant to the terms of said Contract, shall not in any way release either the Contractor or the surety thereunder nor shall any extensions of time granted under the provisions of said contract release either the Contractor or the surety, and notice of such alterations or extensions of the Contract is hereby waived by the surety.

WITNESS our hands this \_\_\_\_\_ day of \_\_\_\_\_, 2022.

(Seal)  
APPROVED:  
\_\_\_\_\_  
(Seal)

\_\_\_\_\_  
Contractor

BY: \_\_\_\_\_

\_\_\_\_\_  
Title

\_\_\_\_\_  
Surety

BY: \_\_\_\_\_

Mailing Address of Surety:

\_\_\_\_\_

\_\_\_\_\_

\_\_\_\_\_

\_\_\_\_\_  
Telephone Number of Surety

**CERTIFICATION OF COMPLIANCE**  
**AFFIRMATIVE ACTION REQUIREMENTS**  
**EQUAL EMPLOYMENT OPPORTUNITY**

For

**ANNUAL ARTERIAL STREET REHABILITATION FY 19-20**  
**CITY PROJECT NO. 5-R-19**

\_\_\_\_\_ Certifies that:  
(Contractor)

It has adopted and approved affirmative action plan in compliance with Title VII of the Civil Rights Act and the Equal Employment Opportunity Act of 1972 and agrees to submit a copy of that plan to the Assistant to the City Manager/Personnel of the City of La Habra for inspection prior to the award of contract.

Signed: \_\_\_\_\_

By: \_\_\_\_\_

Title: \_\_\_\_\_

Date: \_\_\_\_\_

## **APPENDIX “A”**

### **PROJECT LOCATION LIST**

<b>STREET LOCATION</b>	<b>FROM</b>	<b>TO</b>
**CYPRESS	LA HABRA	CAPELLA
**PALM	LA HABRA	N'LY CITY LIMIT
*W. RISNER WAY	IDAHO	650' E/O IDAHO
*WALNUT	LA HABRA	LAMBERT
*WALNUT	WHITTIER	LA PRESA
*OLIVE TREE	IDAHO	W/O SMOKE TREE
*LEMON TREE	OLIVE TREE	W/O SMOKE TREE
*SMOKE TREE	OLIVE TREE	S/O LEMON TREE
*RAIN TREE	IDAHO	LEMON TREE
*CHERRY TREE	RAIN TREE	SOUTH END
*SPRING TREE	LEMON TREE	EAST END
*PINE TREE	SMOKE TREE	WEST END
*OAK TREE	SMOKE TREE	WEST END
*MAPLE TREE	OLIVE TREE	SOUTH END
*BIRCH TREE	OLIVE TREE	SOUTH END

\*See Typical Cross Section "A" Appendix "C"

\*\* See Typical Cross Section "B" Appendix "C"

## **APPENDIX “B”**

### **STANDARD PLANS**

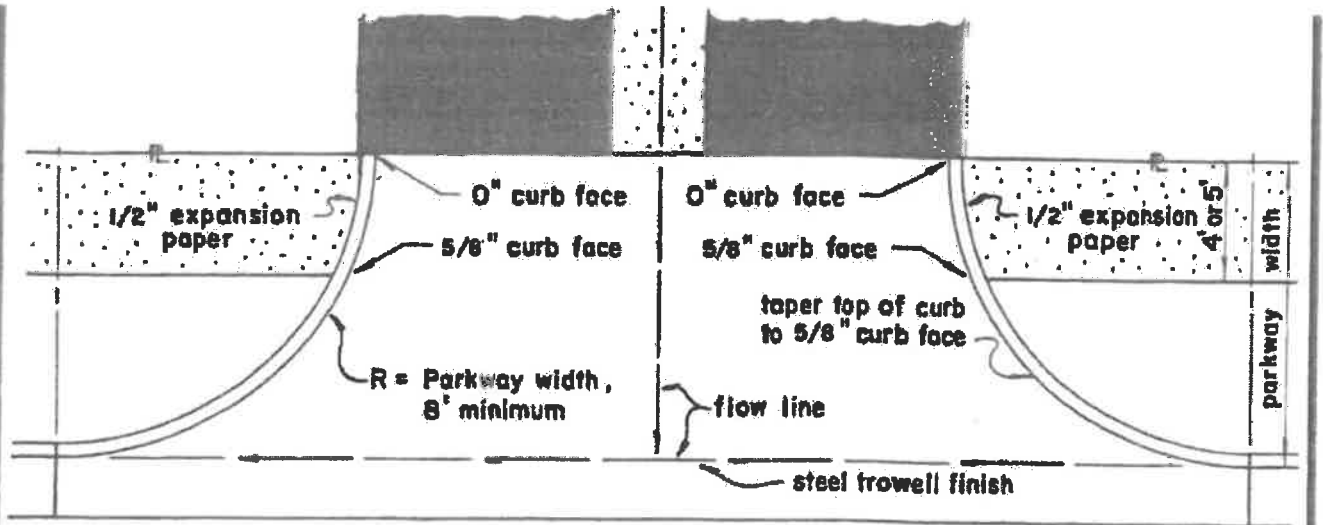

**APRON PLAN**

1/4" expansion papers shall be placed at intervals not to exceed 60' in the concrete gutter with 2 - 36" x 1/2"  $\phi$  dowels wrapped or greased.

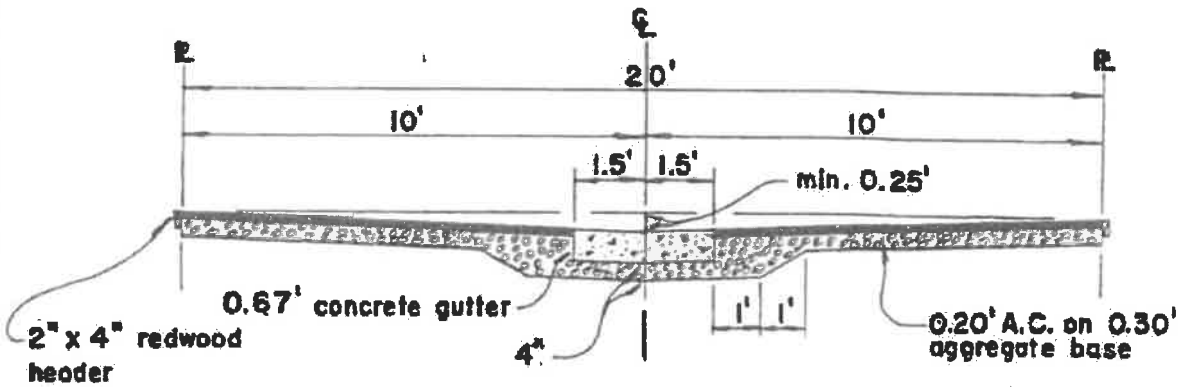

**ALLEY SECTION**

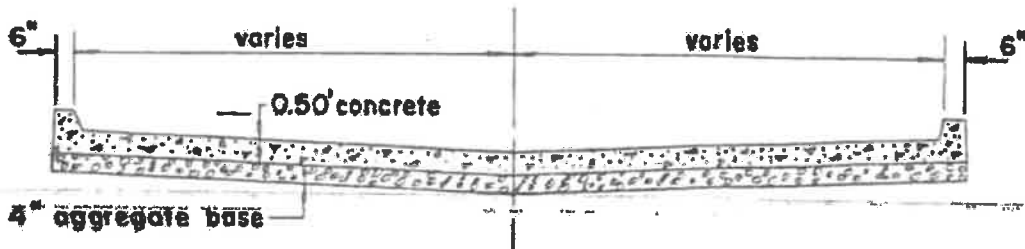

**APRON SECTION**

**AGGREGATE BASE**

Aggregate Base shall be in accordance with Section 200-2.2 of Standard Specification for Public Works Construction.

\* Replaces Std. Detail R-4 Approved 4-15-75

**CONCRETE**

Class 520-C-2500 Per Section 201 of Standard Specification for Public Works Construction.

**CITY OF LA HABRA  
STANDARD ALLEY SECTION**

APPROVED *[Signature]* DATE \_\_\_\_\_

**STANDARD DETAIL R-4**

REV. 9/84

NOTE:

Minimum Distance Between DRIVEWAYS in same lot shall be 22.00 Feet.  
 CURB & GUTTER shall not be poured monolithic with the DRIVEWAY APRON.  
 Property Line

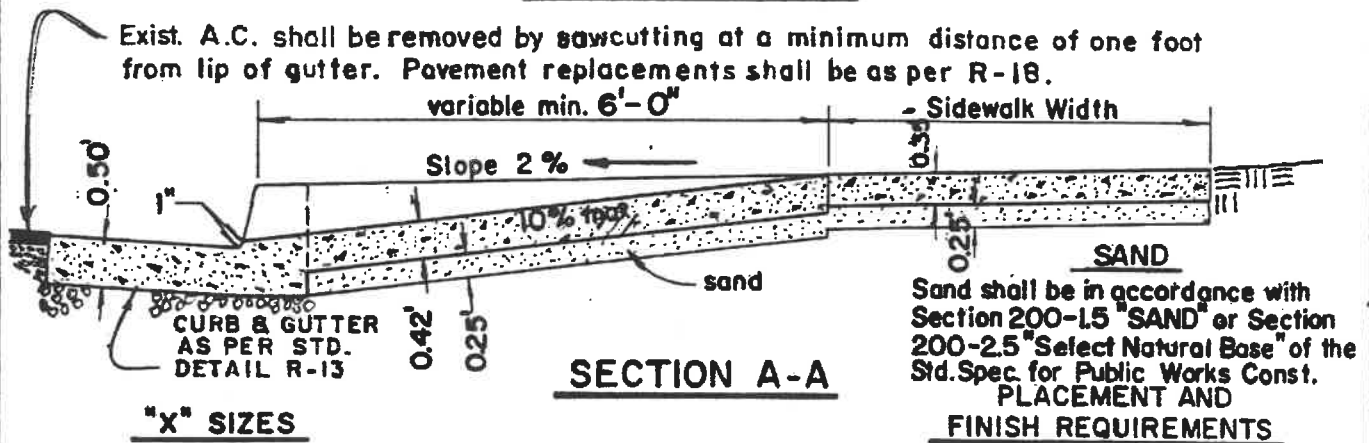
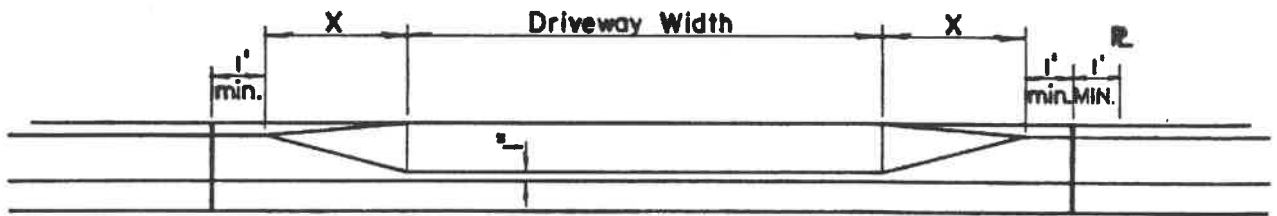
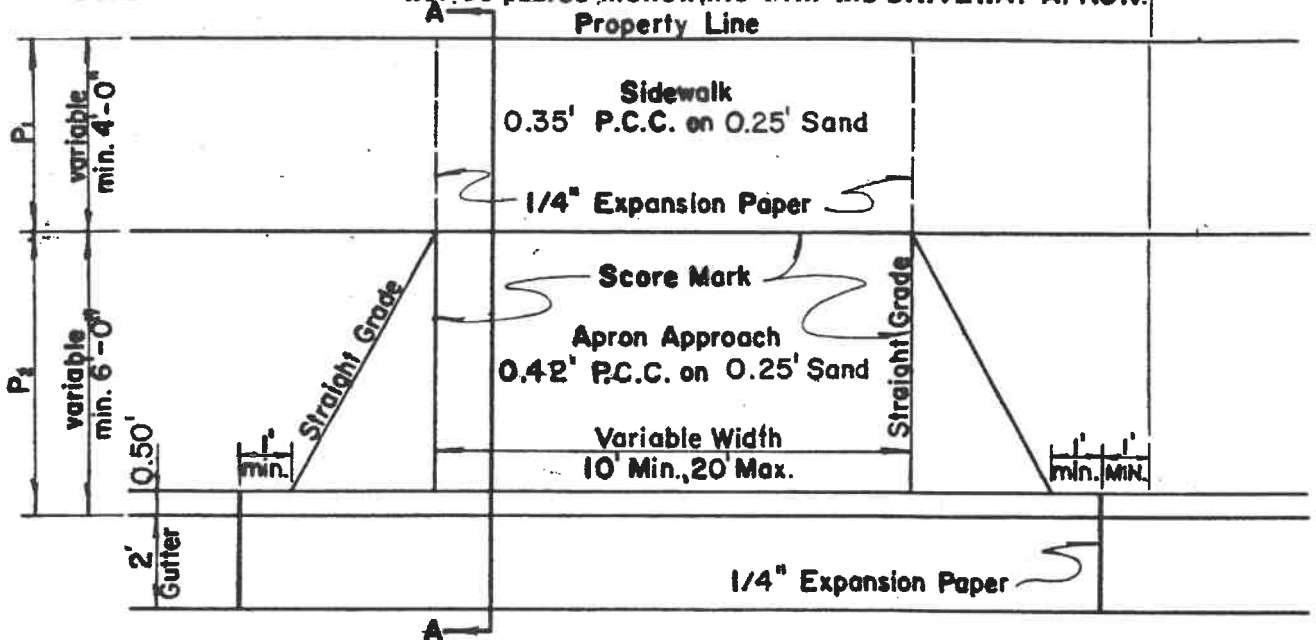

"X" SIZES

8" Curb Height	Residential Street X = 3'
	Arterial Street X = 4'
6" Curb Height	Residential Street X = 2.5'
Curb Height Greater Than 8"	X = 4'

CONCRETE  
 Class 520-C-2500. Per Section 201 of Standard Specification for Public Works Construction.

Fresh concrete shall be struck off and compacted until a layer of mortar has been brought to the surface. The surface shall then be finished to grade with a float and steel troweled smooth. Final finish shall be: coarse broom in P2 area, fine broom in P1 area.

REV. 7-22-85 REV. 2/24/86  
 REV. 12-15-83

\* Replaces Sto. Detail R-9 Approved 4-15-75

NOTE: Minimum Distance Between DRIVEWAYS in same lot shall be 22.00 Feet.  
 CURB & GUTTER shall not be poured monolithic with the DRIVEWAY APRON.

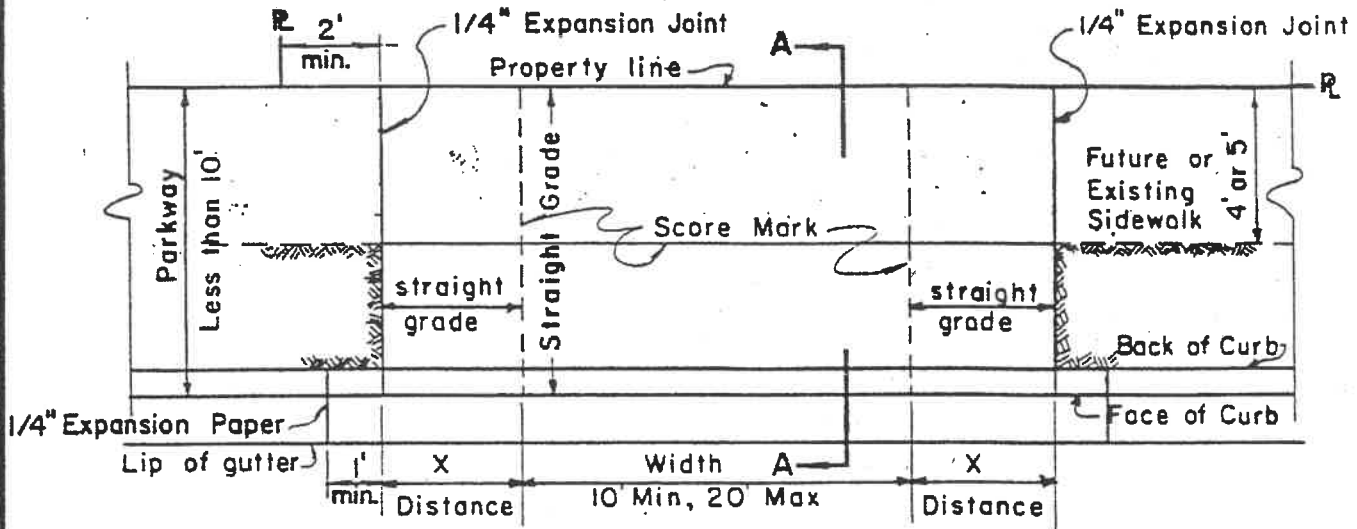

When Curb Face Is Less Than 8" - X Distance = 2.50'  
 When Curb Face Is 8" Or More - X Distance = 3.00'

**PLAN VIEW**

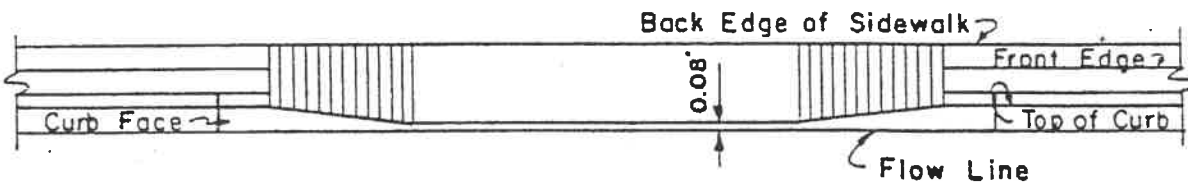

**ELEVATION VIEW**

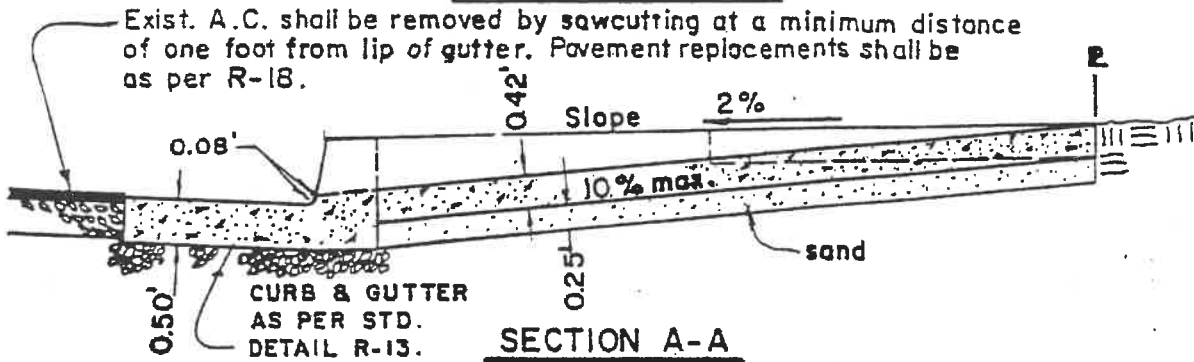

**CONCRETE**

Class 520-C-2500 Per Section 201 of Standard Specification for Public Works Construction.

**SAND**

Sand shall be in accordance with Section 200-1.5 "SAND" or Section 200-2.5 "Select Natural Base" of Standard Specification for Public Works Construction.

**PLACEMENT AND FINISH REQUIREMENTS**

Fresh concrete shall be struck off and compacted until a layer of mortar has been brought to the surface. The surface shall then be finished to grade with a float and steel troweled smooth and final finished with a coarse broom. Brooming shall be transverse to the line of traffic. Concrete adjacent to expansion paper shall be finished with an edger tool.

REV	DATE	DESCRIPTION	BY
Δ	6-20-77	Rev. Spec. to conform to S.S.	W/S
			APD

\* REPLACES STD. DETAIL R-10  
 APPROVED 4-15-75

REV. 12-15-83 REV. 2-24-86

**CITY OF LA HABRA**

STANDARD RESIDENTIAL DRIVEWAY PARKWAY WIDTH < 10'

APPROVED R.L. Boardman DATE \_\_\_\_\_ | **STANDARD DETAIL R-10**



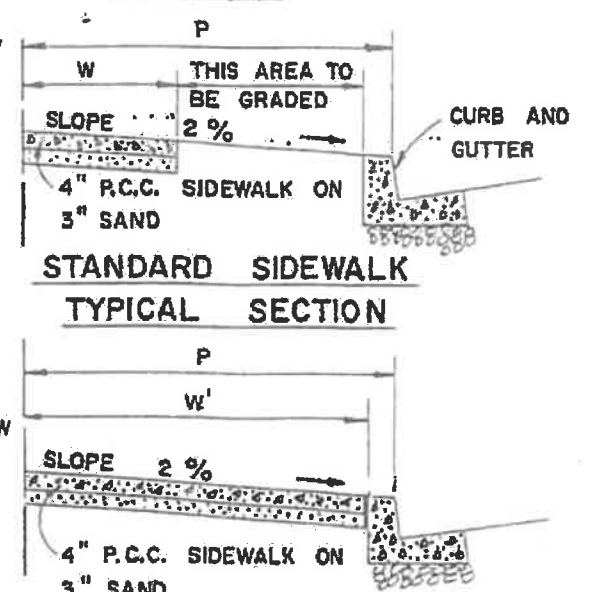
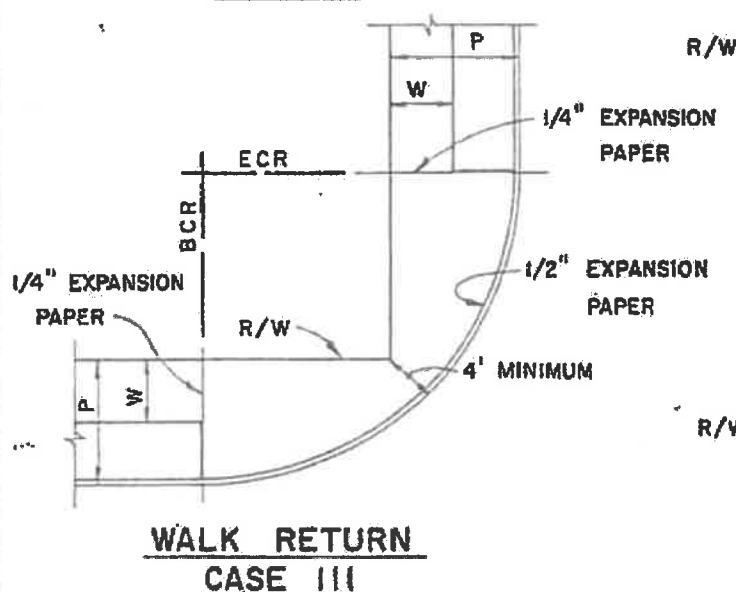
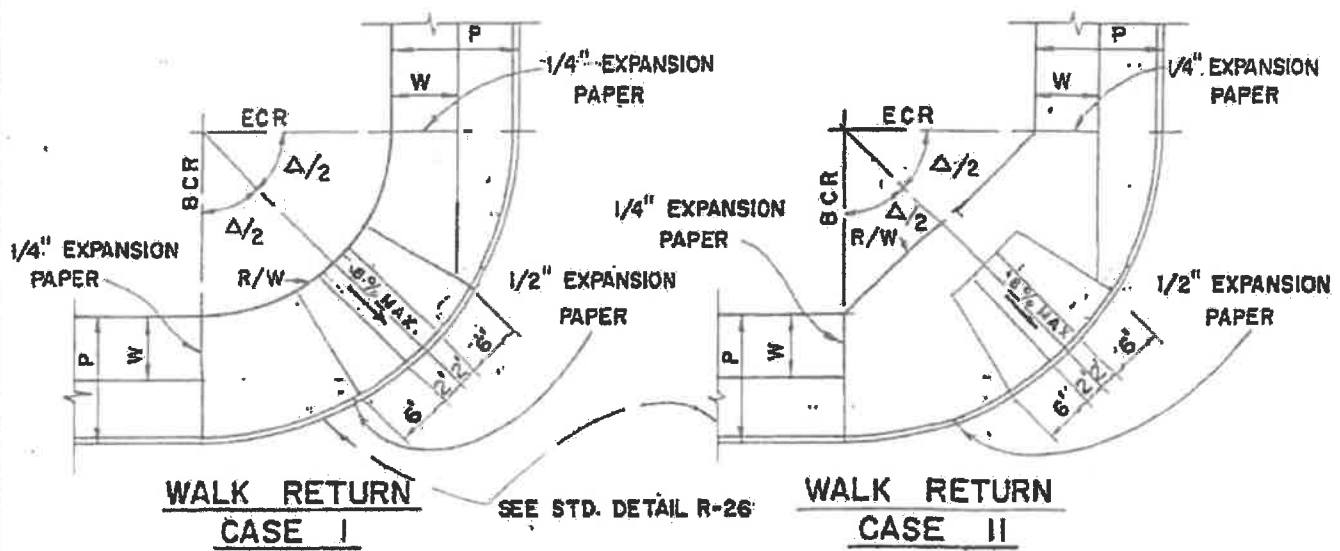

P = PARKWAY WIDTH AS NOTED ON PLAN  
 W = 4' RESIDENTIAL & COLLECTOR STREETS  
 W = 5' ARTERIAL HIGHWAYS  
 W' = PARKWAY WIDTH

- NOTES:**
1. 1/4" EXPANSION PAPERS SHALL BE PLACED AT 60' INTERVALS.
  2. CONCRETE-- CLASS 520-C-2500 PER SECTION 201 OF STANDARD SPECIFICATIONS FOR PUBLIC WORKS CONSTRUCTION.
  3. WEAKENED JOINTS SHALL BE PLACED AT 20' INTERVALS.
  4. SAND SHALL HAVE A SAND EQUIVALENT OF NOT LESS THAN 30.

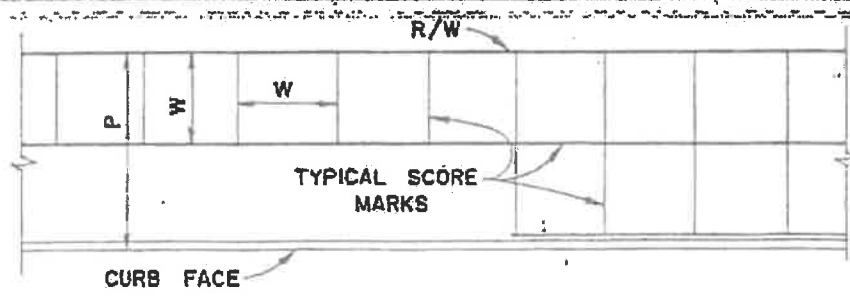

# CITY OF LA HABRA

## STANDARD SIDEWALK RETURNS & MARKINGS

APPROVED *R. L. Beaudone* DATE 1-15-71 STANDARD DETAIL R-14

REV. 1-7-87; -7-G-87

5-30-78

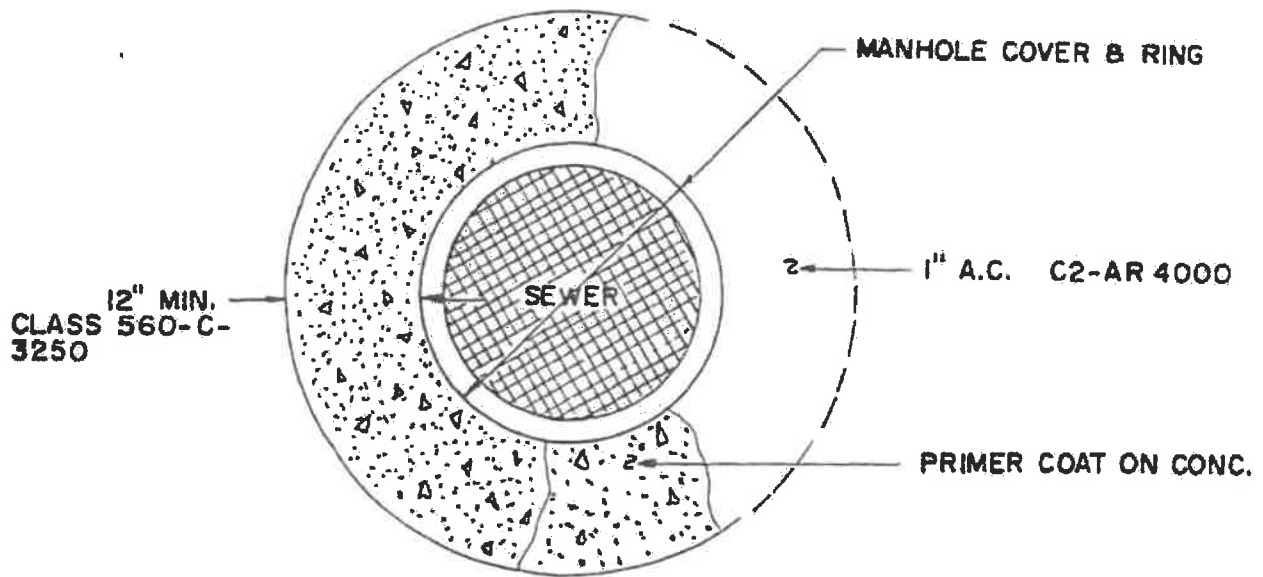

### PLAN VIEW

CONC. MAY BE CIRCULAR OR SQUARE IN SHAPE WITH A MINIMUM DISTANCE OF 12" BETWEEN EDGE OF CONC. AND LIP OF M.H. RING.

MANHOLES MAY BE ADJUSTED TO GRADE USING BRICK AND MORTAR OR PRECAST RINGS AT THE CONTRACTORS OPTION.

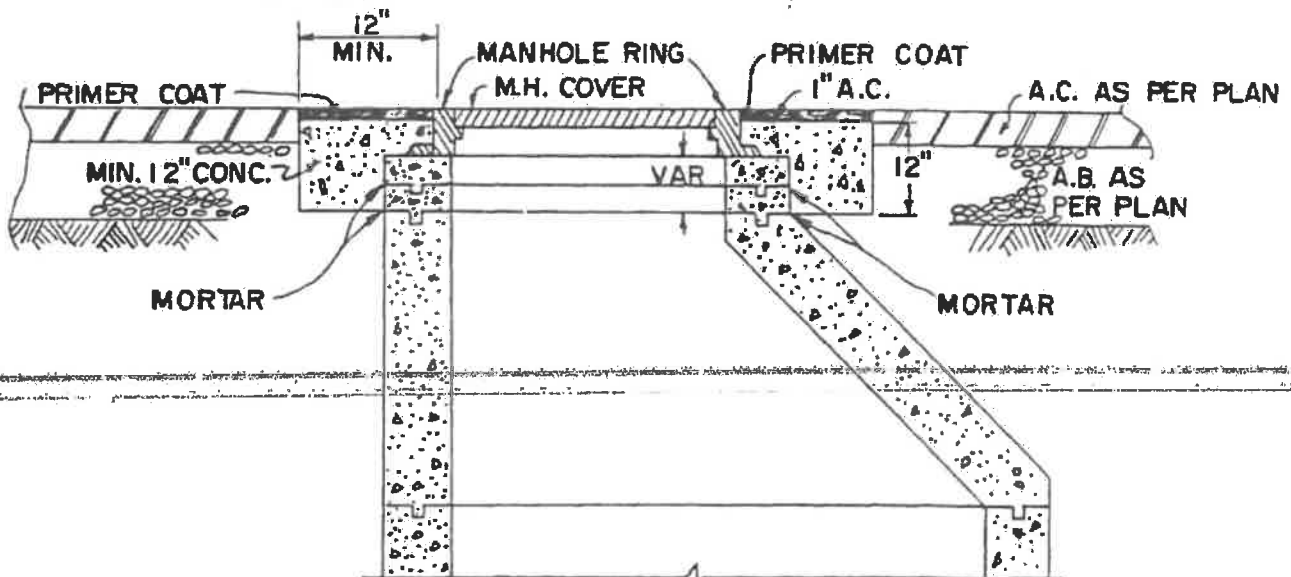

### CROSS SECTION

CITY OF LA HABRA

MANHOLE ADJUSTMENT DETAILS

APPROVED *Rob B...* DATE 1-28-86

STANDARD DETAIL R-19A

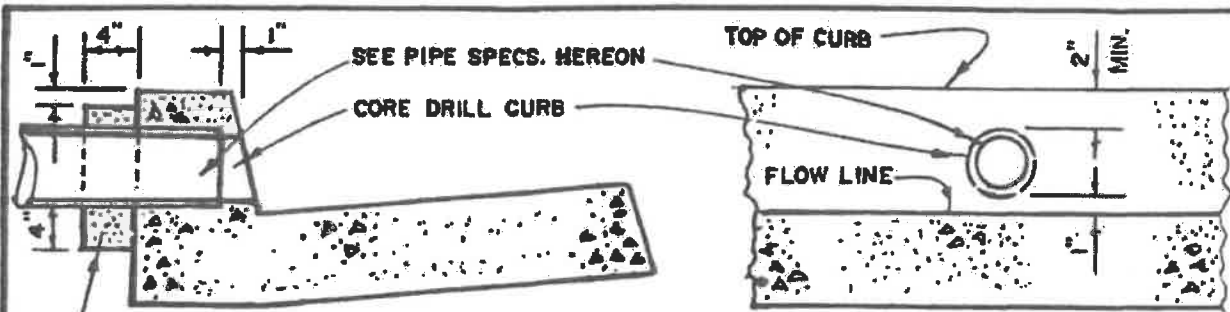

**SINGLE CURB DRAIN THRU EXISTING CURB**

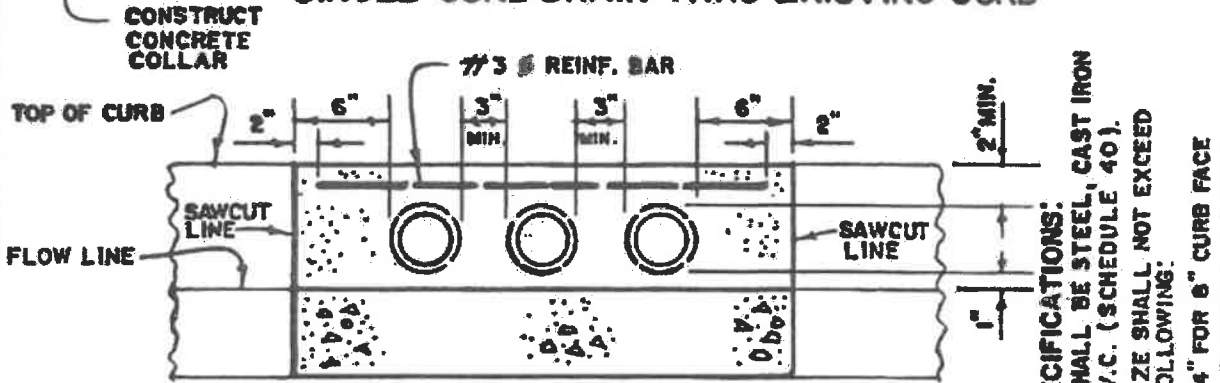

**MULTIPLE PIPE CURB DRAIN  
REMOVE AND REPLACE CURB & GUTTER.**

**PIPE SPECIFICATIONS:**  
 PIPE SHALL BE STEEL, CAST IRON  
 OR P.V.C. (SCHEDULE 40).  
 PIPE SIZE SHALL NOT EXCEED  
 THE FOLLOWING:  
 4" FOR 6" CURB FACE  
 3" FOR 6" CURB FACE

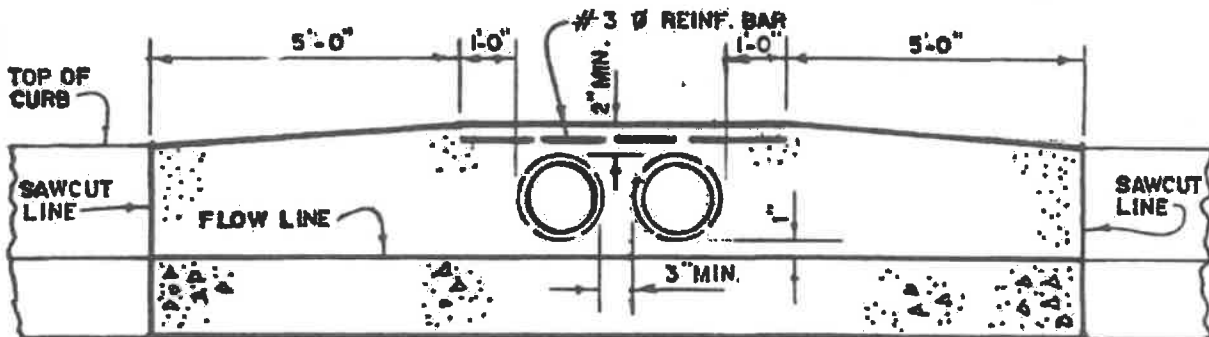

**CURB DRAIN LARGER THAN SPECIFIED MAXIMUM PIPE SIZE  
CURB, GUTTER AND SIDEWALK SHALL BE REMOVED AND BE REPLACED.**

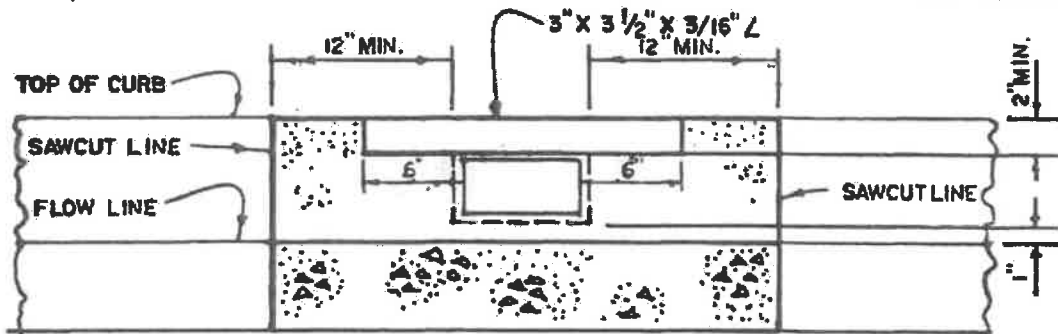

**PRECAST BOX CURB DRAIN  
REMOVE AND REPLACE CURB & GUTTER.**

MAXIMUM WIDTH BOX SHALL BE 12" UNLESS APPROVED BY CITY ENGINEER

**CITY OF LA HABRA  
STANDARD CURB DRAINS**

APPROVED *R.L. Dunsford* DATE 7-26-83 **STANDARD DETAIL R-20**

REV. 7-22-85

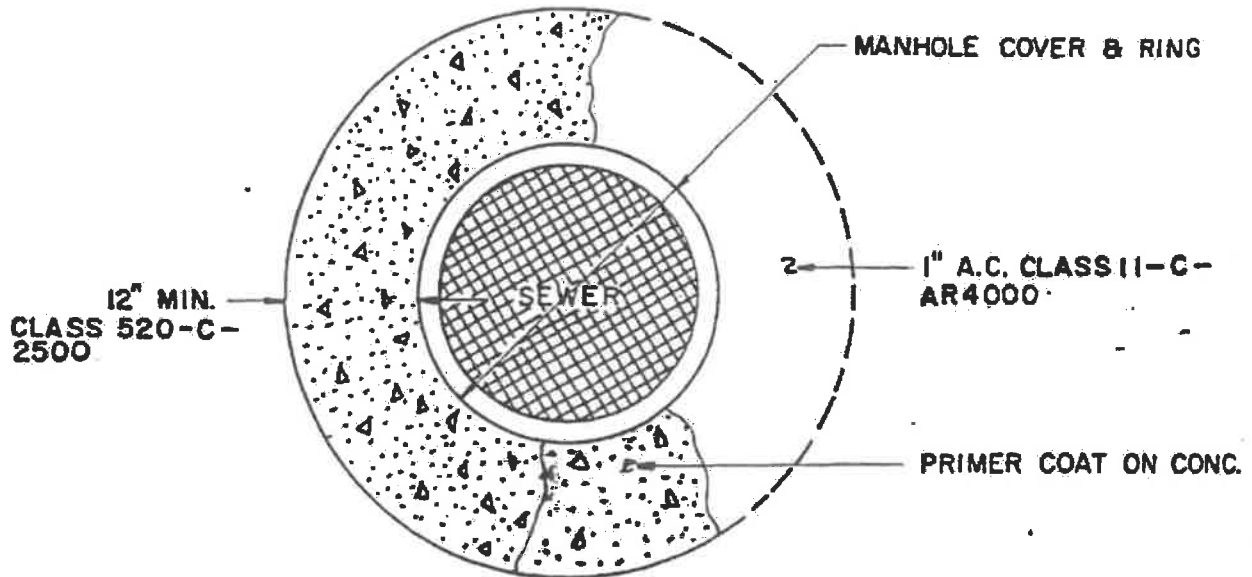

**PLAN VIEW**

CONC. MAY BE CIRCULAR OR SQUARE IN SHAPE WITH A MINIMUM DISTANCE OF 12" BETWEEN EDGE OF CONC. AND LIP OF M.H. RING.

MANHOLES MAY BE ADJUSTED TO GRADE USING BRICK AND MORTAR OR PRECAST RINGS AT THE CONTRACTORS OPTION.

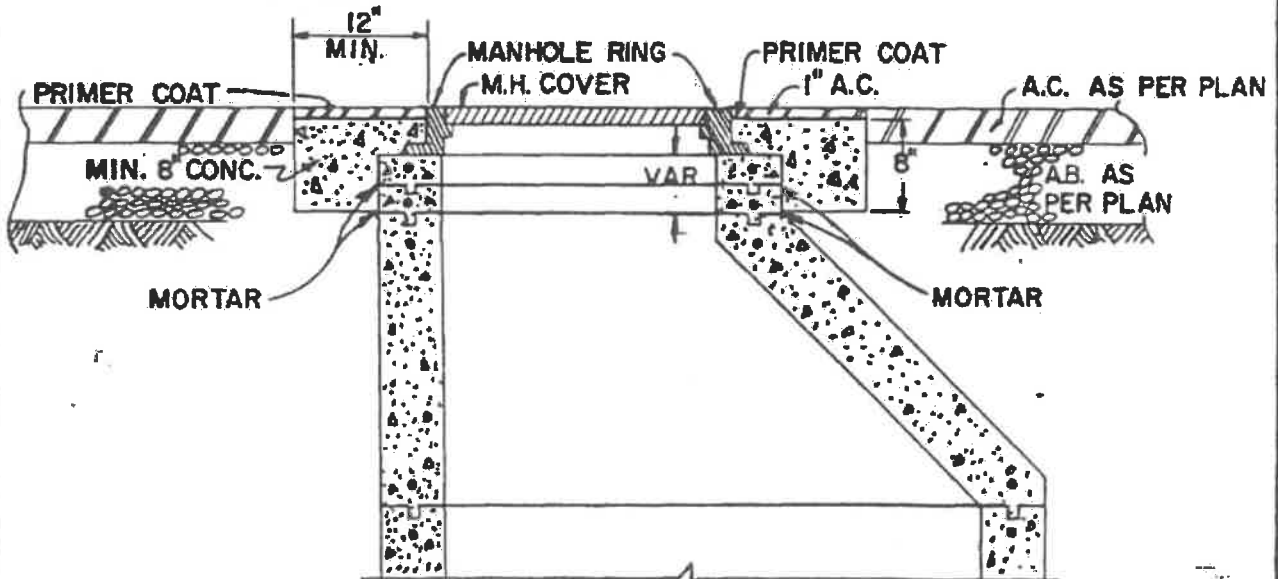

**CROSS-SECTION**

**CITY OF LA HABRA**

**MANHOLE ADJUSTMENT DETAILS**

APPROVED *H.W. [Signature]* DATE *6/15/63* STANDARD DETAIL R-19

REV. 12-27-83; 4-17-84; 9/84; 8/25/87

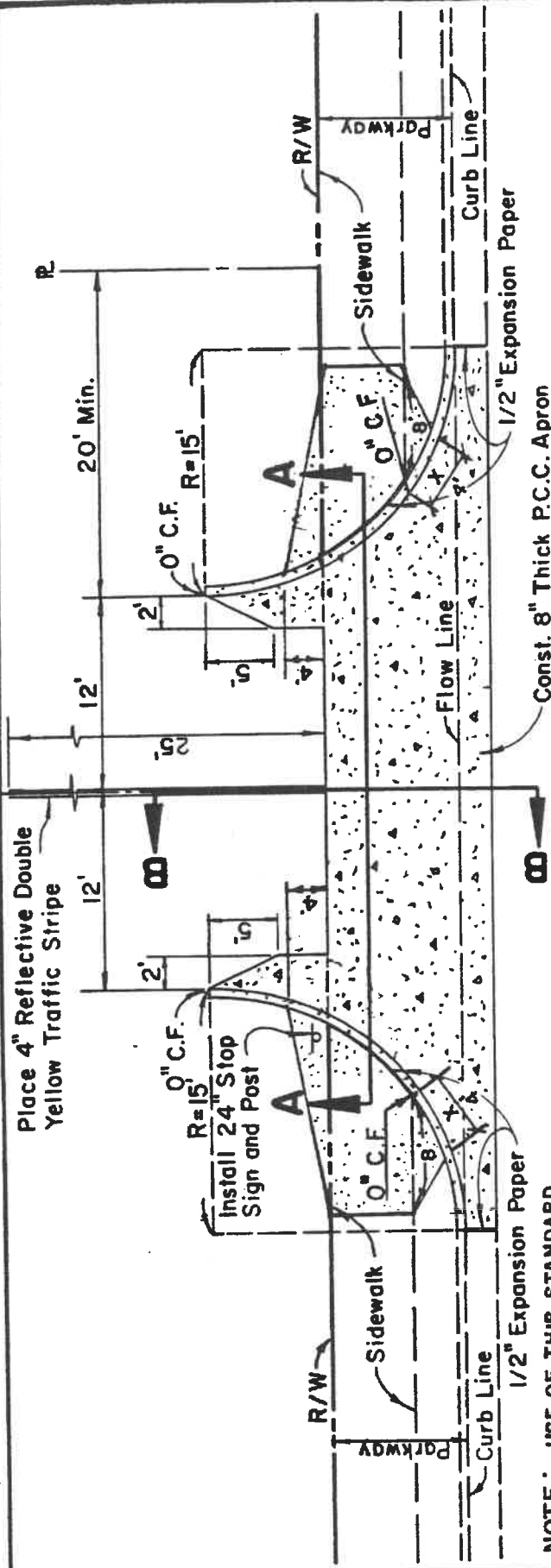

NOTE: USE OF THIS STANDARD SHALL BE SUBJECT TO THE FOLLOWING CONDITIONS:

1. Approval of the City Engineer.
2. Distance from standard drive apron shall be not less than 50 feet.
3. Distance from street intersection or Type I or Type II drive approach shall be not less than 250 feet.

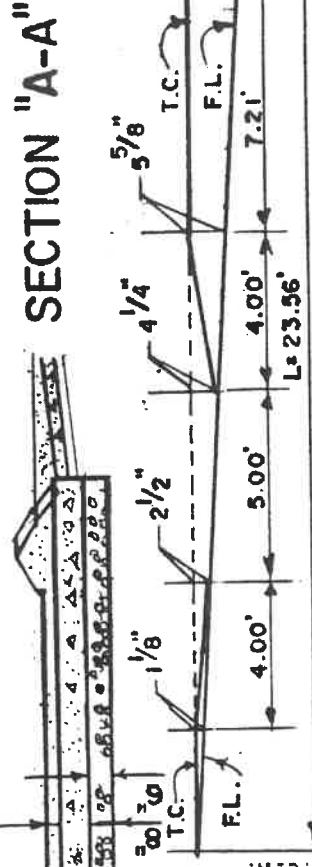

PROFILE AROUND CURB FACE PARKWAY = 8'

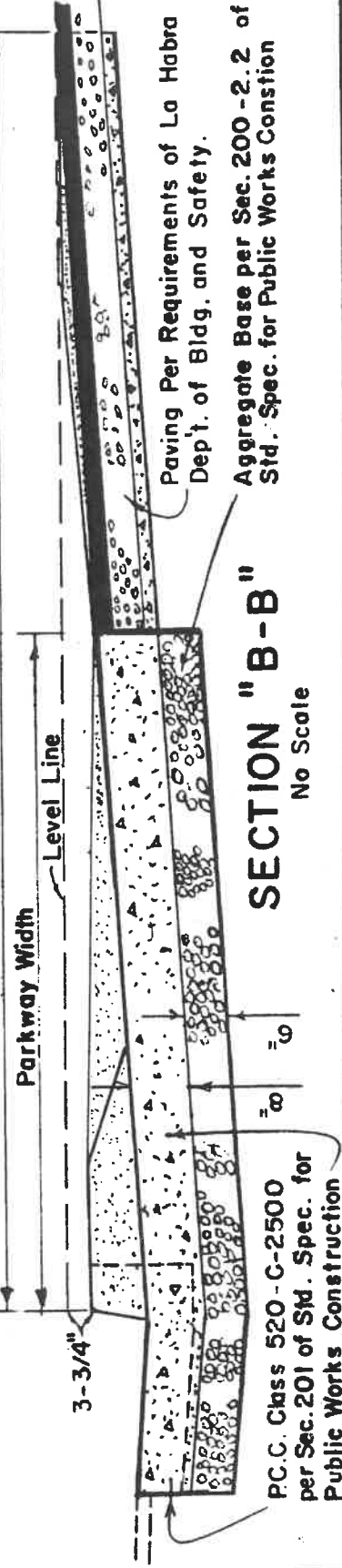

P.C.C. Class 520-C-2500 per Sec. 201 of Std. Spec. for Public Works Construction

Paving Per Requirements of La Habra Dept. of Bldg. and Safety. Aggregate Base per Sec. 200-2.2 of Std. Spec. for Public Works Constn

No Scale

CITY OF LA HABRA  
TYPE II DRIVE APPROACH

APPROVED *R. L. Rosendale* DATE \_\_\_\_\_

STANDARD DETAIL R-23

## NOTES:

1. SIGNS IN MEDIANS SHALL BE PLACED AT MIDPOINT OF MEDIAN.
2. SIGN POSTS SHALL BE 2 1/2" Ø GALVANIZED PIPE OR 2" UNISTRUT POST.
3. "X" DISTANCE UNLESS OTHERWISE SPECIFIED BY PLANS OR WORK ORDERS OR APPROVED BY CITY ENGINEER SHALL BE AS INDICATED IN THE TABLE SHOWN BELOW.

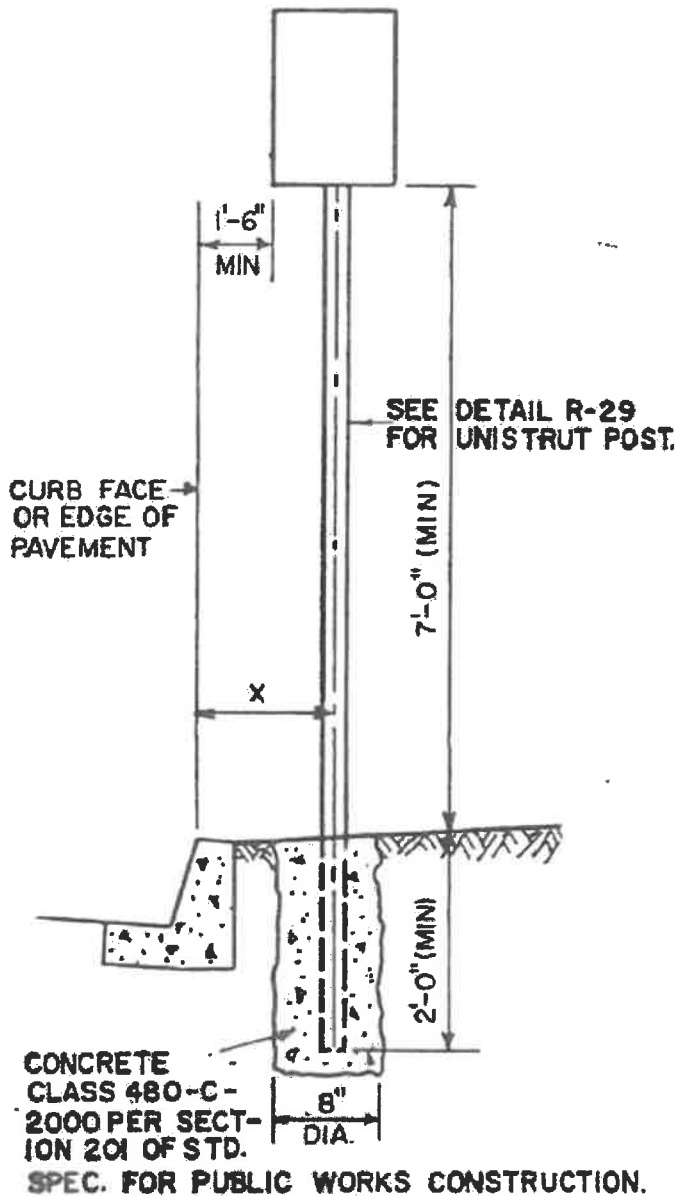

SIGN SHAPE	WIDTH W IN INCHES	DISTANCE X IN INCHES
RECTANGLE 	12	24
	18	27
	24	30
	30	33
	36	36
	45	40
DIAMOND 	24	35
	30	39
	36	69
	45	81

## CITY OF LA HABRA

HEIGHT AND LATERAL POSITION FOR SIGNS

APPROVED *R. L. Burdette* DATE 6-1-73

STANDARD DETAIL

R-25

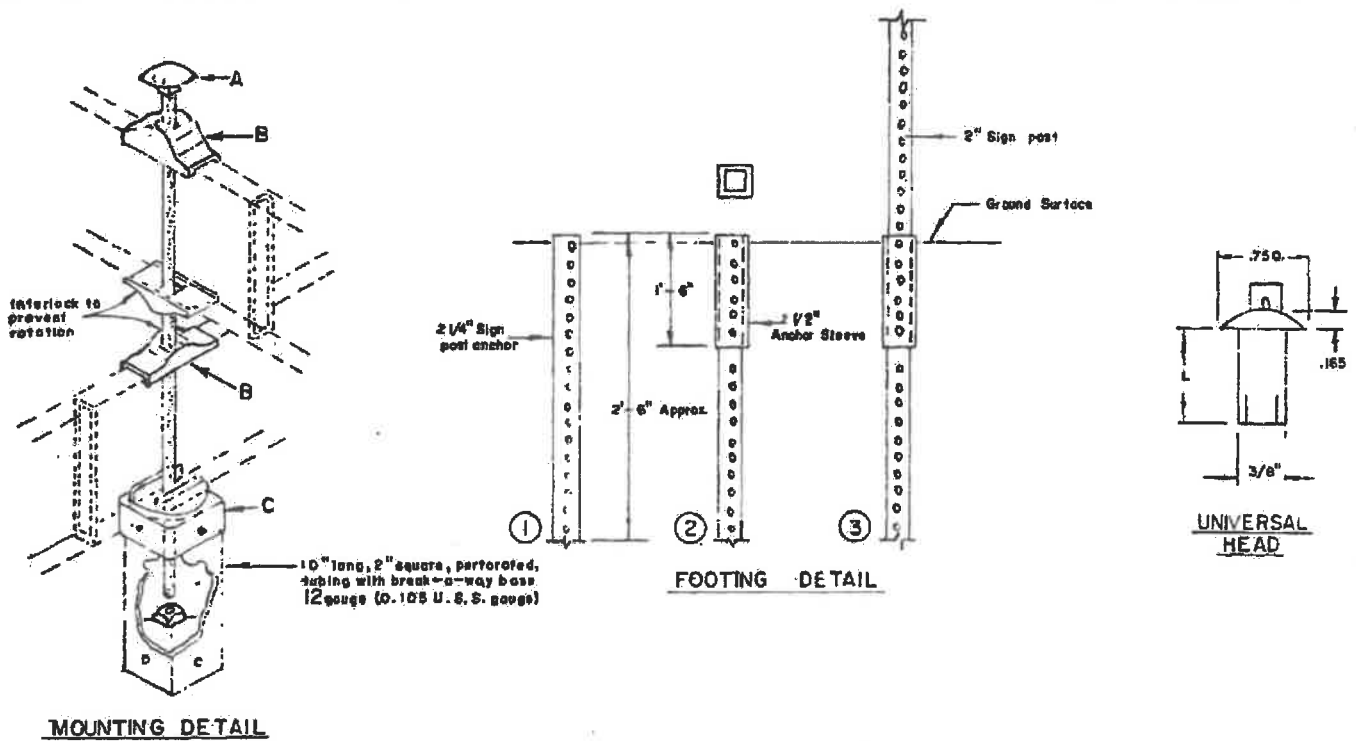

## NOTES

- ① Drive sign post anchor into ground approximately 2'-6" depending on local soil conditions. Leave one hole exposed above ground for bolt connection. Post anchor is the next size larger tube than sign post.
  - ② Drive in anchor sleeve which is a size larger than post anchor and about 18 inches long. The sleeve insures more strength at critical bending area and provides a double wall thickness for the break-away post function. When driving sleeve, leave post anchor 2 or 3 inches above surface as friction from dirt between anchor and sleeve causes anchor to drive slightly with sleeve. The top rivet hole of the anchor and sleeve assembly shall remain exposed.
  - ③ Insert sign post and rivet in place with two 5/16" Universal Head Drive Rivets, one facing traffic and one perpendicular to traffic.
- A. Use a 5/8" X 15" carriage bolt for 6" and 6" sign combination.
- B. Ornamental top and center across saddle shall be anodized and cast from aluminum casting alloy 319.
- C. JS-1 Street Assembly.

# CITY OF LA HABRA

## STANDARD STREET SIGN INSTALLATION

APPROVED *Re. L. ...* DATE 11-9-77

STANDARD DETAIL

R-29

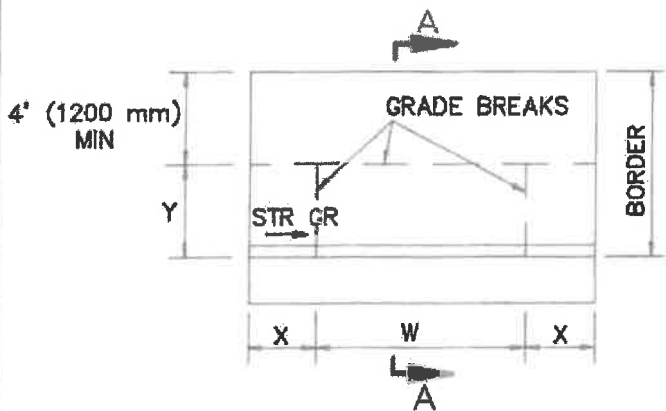

TYPE A

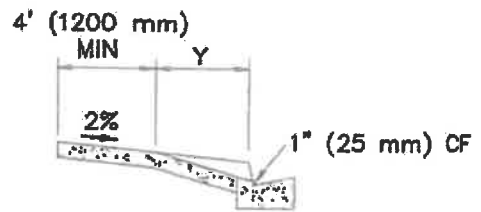

SECTION A-A

CURB FACE, inches (mm)	X, inches (mm)	Y, inches (mm)
6" (150) or less	3'-0" (900)	4'-0" (1200)
7" (175)	3'-6" (1050)	4'-9" (1425)
8" (200)	4'-0" (1200)	5'-8" (1700)
9" (225)	4'-6" (1350)	6'-6" (1950)
10" (250)	5'-0" (1500)	7'-3" (2175)
11" (275)	5'-6" (1650)	8'-0" (2400)
12" (300) or more	6'-0" (1800)	8'-9" (2625)

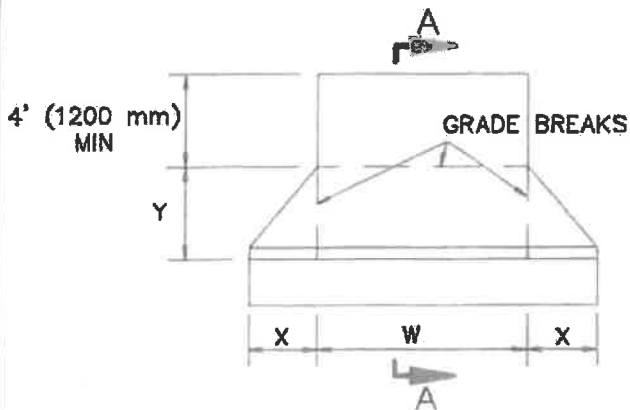

TYPE B

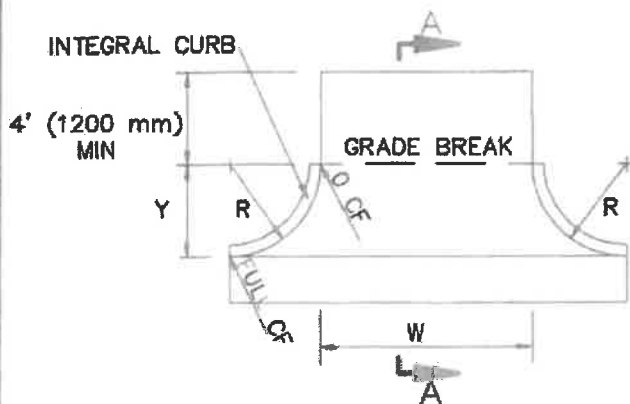

TYPE C

**NOTES:**

1. RESIDENTIAL DRIVEWAYS SHALL BE 4" (100 mm) THICK PCC.
2. COMMERCIAL DRIVEWAYS SHALL BE 6" (150 mm) THICK PCC.
3. WEAKENED PLANE JOINTS SHALL BE INSTALLED AT BOTH SIDES OF A DRIVEWAY AND AT 10' (3.0 m) INTERVALS.
4. CURB FOR TYPE C DRIVEWAY SHALL BE INTEGRAL AND MATCH ADJACENT CONSTRUCTION.
5. REFER TO LOCAL DEVELOPMENT REGULATIONS FOR AMERICANS WITH DISABILITIES ACCESS REQUIREMENTS AND MAXIMUM PERMITTED DRIVEWAY WIDTHS.

STANDARD PLANS FOR PUBLIC WORKS CONSTRUCTION

PROMULGATED BY THE  
PUBLIC WORKS STANDARDS INC.  
GREENBOOK COMMITTEE  
1984  
REV. 1986, 2009

**DRIVEWAY APPROACHES**

USE WITH STANDARD SPECIFICATIONS FOR PUBLIC WORKS CONSTRUCTION

STANDARD PLAN

**110-2**

SHEET | OF 1

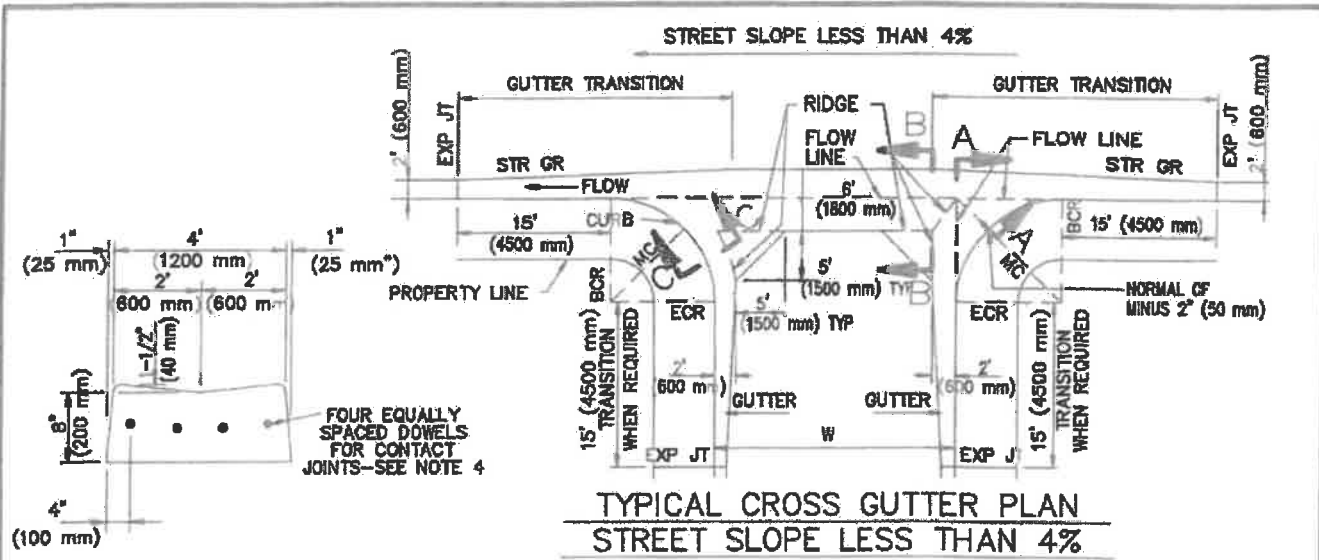

TYPICAL CROSS GUTTER PLAN  
STREET SLOPE LESS THAN 4%

LONGITUDINAL  
GUTTER

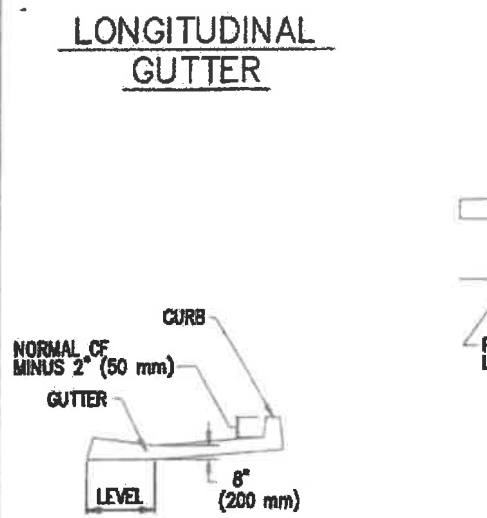

SECTION A-A

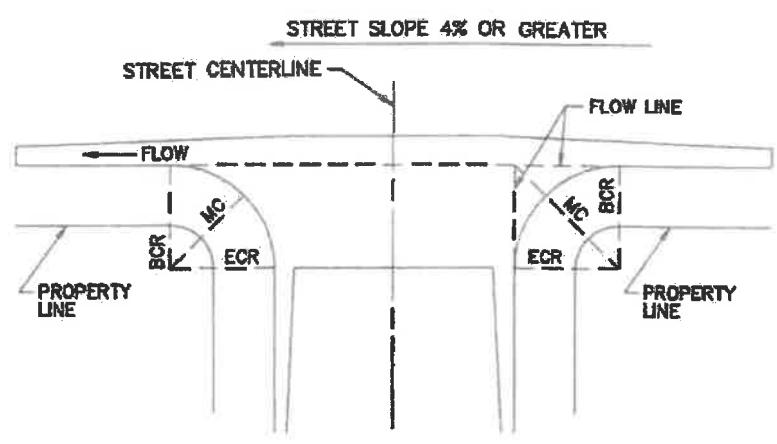

TYPICAL CROSS GUTTER PLAN  
STREET SLOPE MORE THAN 4%

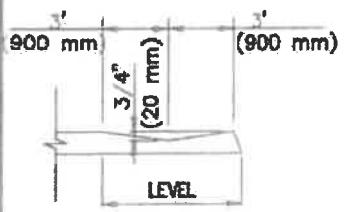

SECTION B-B

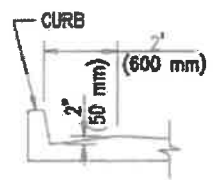

SECTION C-C

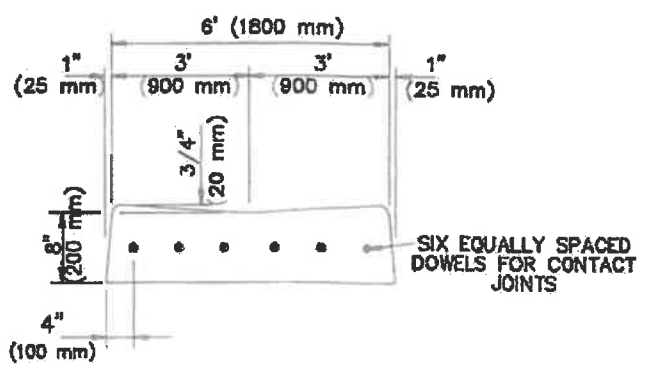

SECTION D-D

STANDARD PLANS FOR PUBLIC WORKS CONSTRUCTION

PROMULGATED BY THE  
PUBLIC WORKS STANDARDS INC.  
GREENBOOK COMMITTEE  
1984  
REV. 1986, 2009

**CROSS AND LONGITUDINAL GUTTERS**

USE WITH STANDARD SPECIFICATIONS FOR PUBLIC WORKS CONSTRUCTION

STANDARD PLAN

**122-2**

SHEET 1 OF 2

PROJECT NO. 15-31-15  
 COUNTY: ...  
 REGISTERED CIVIL ENGINEER  
 DATE: May 31, 2018  
 APPROVAL DATE: ...  
 SEAL: ...

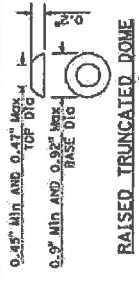

RAISED TRUNCATED DOME  
 2.3" MIN AND 2.4" MAX SPACING  
 CENTER TO CENTER

**DETECTABLE DOME PATTERN (IN-LINE)**  
**RAISED TRUNCATED DOME PATTERN (IN-LINE)**

- NOTES:  
 See Note 10  
 1. As site conditions dictate, Case A through Case G curb ramps may be used for corner installations similar to those shown in Detail A and Detail B. The case of curb ramps used in Detail A do not have to be the same. Case A conditions dictate, for specific site conditions, including the conditions to existing sidewalks, see Project Plans.  
 2. 12" distance from curb to back of sidewalk is top short to accommodate ramps and 4"-2" platform (landing) as shown in Case A, the sidewalk may be depressed longitudinally as in Case B or C or may be vided as in Case D.  
 3. When ramp is located in center of curb return, crosswalk configuration must be similar to that shown for Detail B.  
 4. As site conditions dictate, the retaining curb along and the flared side of the Case G ramp shall be constructed in reversed position.  
 5. The ramp portion of the curb ramp is a typical rectangle, unless modified in the Project Plans.  
 6. Side slope of ramp flares vary uniformly from a maximum of 4.0% at curb to conform with longitudinal sidewalk slope adjacent to top of the ramp, except in Case C and Case F.  
 7. The adjacent surfaces at transitions of curb ramps to walks, gutters, and streets shall be of the same level.  
 8. Counter slopes of adjoining gutters, and road surfaces immediately adjacent to and within 24 inches of the curb ramp shall not be steeper than 3/20th (15.0%). Curb pan slope shall not exceed 1" of depth for each 2'-0" of width.  
 9. Transition gutter pan slope from 1" of depth for each 2'-0" of width to match typical gutter pan slope per Standard Plan A87A.  
 10. The detectable warning surface will be a rectangle as shown at back of curb, unless modified in the Project Plans. Curb ramps shall have a detectable warning surface that extends the full width of the ramp except a maximum gap of 1 inch is allowed on each side of the ramp. Detectable warning surfaces shall conform to the requirements in the Standard Specifications.  
 11. Sidewalk and ramp thickness, "T", shall be 3/2" minimum.  
 12. Utility pull boxes, manholes, vaults and all other utility facilities within the boundary of the curb ramp will be relocated or adjusted to grade by the owner prior to, or in conjunction with, curb ramp construction.  
 13. Detectable warning surface may have to be cut to allow removal of utility covers while maintaining detectable warning width and depth.

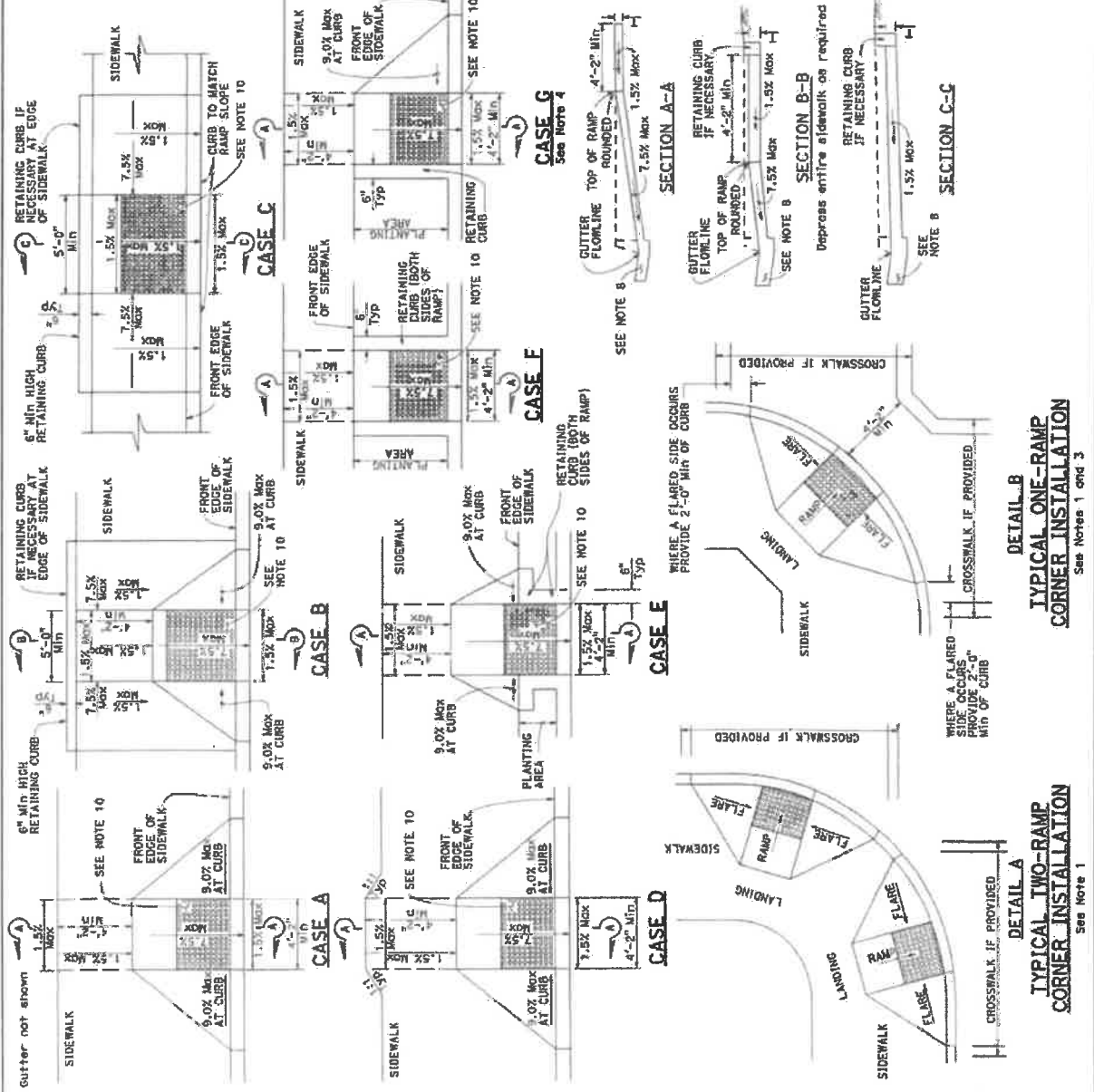

**DETAIL B**  
**TYPICAL ONE-RAMP**  
**CORNER INSTALLATION**  
 See Notes 1 and 3

**DETAIL A**  
**TYPICAL TWO-RAMP**  
**CORNER INSTALLATION**  
 See Note 1

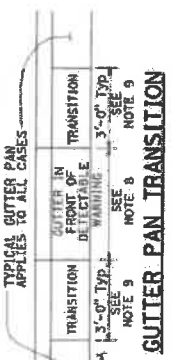

**GUTTER PAN TRANSITION**  
 TYPICAL GUTTER PAN APPLIES TO ALL CASES

STATE COUNTY ROUTE TOTAL ANGLE 1/2 INCH 1/4 INCH 1/8 INCH 1/16 INCH

REGISTERED CIVIL ENGINEER

NOV 31, 2018

PLANS APPROVAL DATE

THE STATE OF CALIFORNIA OR ITS OFFICIALS ARE NOT RESPONSIBLE FOR ANY ACCIDENTS OR DAMAGES THAT MAY BE CAUSED BY THE USE OF THESE PLANS OR THE INFORMATION CONTAINED THEREIN.

**NOTES:**

1. Accessible parking spaces serving a particular building shall be located on the shortest accessible route of travel from adjacent parking to an accessible entrance. In parking facilities that do not serve a particular building, accessible parking shall be located nearest accessible routes of travel to an accessible pedestrian entrance of the parking facility.
2. One in every six accessible off-street parking stalls, but not less than one, shall be served by an accessible aisle of 8'-0" width with a 3'-0" wide accessible aisle. The R99 (CA) sign shall be mounted below the R99B (CA) plaque on the R99 (CA) sign.
3. In each parking stall, a curb or parking bumper shall be provided to prevent encroachment of vehicles over the required 8'-0" minimum width. The curb or bumper shall be 3'-0" high and shall be 1'-0" wide. The curb or bumper shall be 1'-0" from the edge of the parking stall. For more parking bumper requirements, see the Standard Specifications.
4. Parking spaces and access aisles shall be level with surface slopes not exceeding 1.5% in all directions.
5. Table A shall be used to determine the required number of accessible parking stalls in each parking lot or garage.
6. Where Plaque R99B (CA), Sign R99C (CA) or Sign R7-8b are installed, the bottom of the sign or plaque panel shall be a minimum of 7'-0" above the surrounding surface.
7. Curb ramps shall conform to the details shown on Standard Plan 88A.
8. Blue paint, instead of white, may be used for marking accessibility aisles in areas where snow may cause white markings to not be visible.
9. The word "NO PARKING" shall be painted in white letters no less than 1 1/2" high on each side of the aisle with a 4" spacing between enforcement officials. See Standard Plan 89B for details of the "NO PARKING" pavement marking.
10. A R100B (CA) sign shall be posted in a conspicuous place of each parking lot or garage. The sign shall include the address and visible from each stall. The sign shall include the address where the towed vehicle may be reclaimed and the telephone number of the local traffic law enforcement agency.
11. Where a simple (non-van) accessible parking space is provided, the loading and unloading access aisle shall be on the passenger side of the vehicle as the vehicle is going forward into the parking space.
12. Where a van accessible parking space is provided, the loading and unloading access aisle shall be 9'-0" wide minimum and shall be on the passenger side of the vehicle as the vehicle is going forward into the parking space.
13. Accessible Parking Only Sign shall be Sign R99C (CA) or Sign R99 (CA) with Plaque R99B (CA).

**LEGEND**

ISA = International Symbol of Accessibility

STATE OF CALIFORNIA  
DEPARTMENT OF TRANSPORTATION

**ACCESSIBLE PARKING OFF-STREET**

NO SCALE

A90A

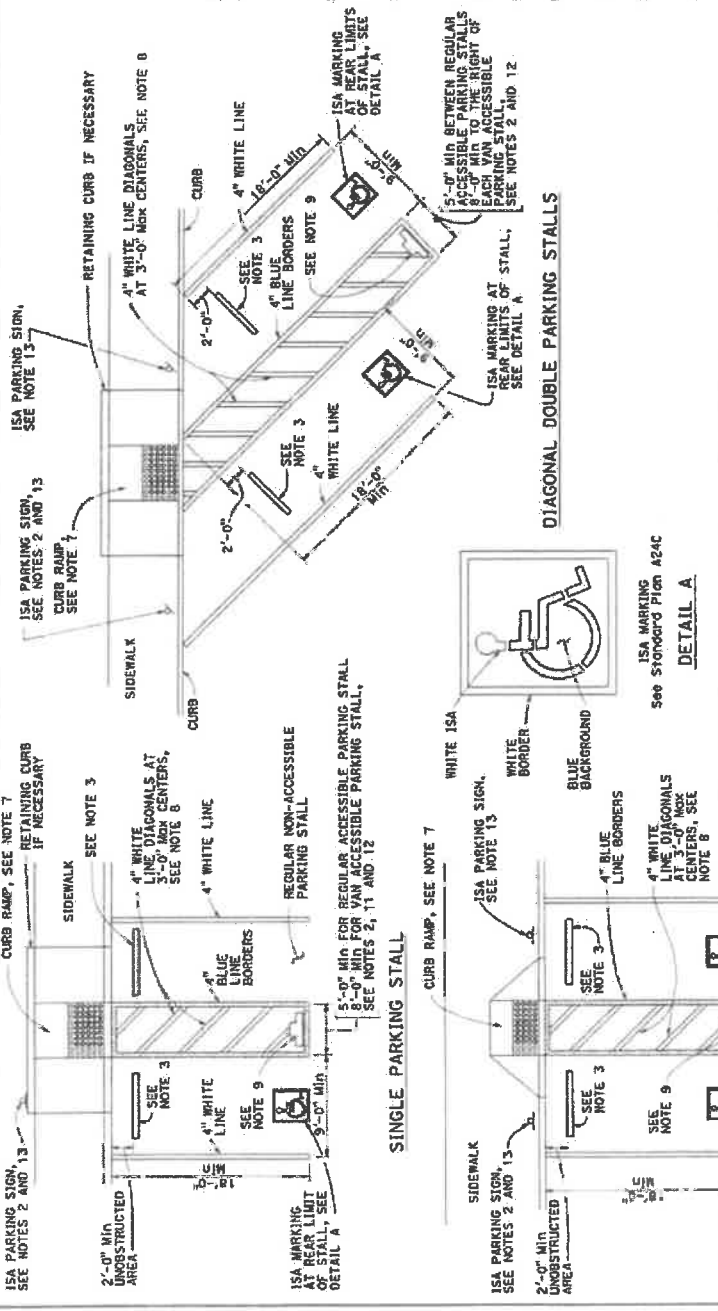

SIGN R100B (CA)  
See Note 10

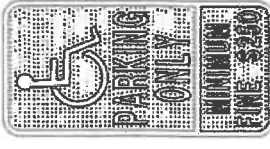

SIGN R99C (CA)  
See Note 6



SIGN R99 (CA)  
See Note 6



PLAQUE R99B (CA)  
See Note 6

**TABLE A**

TOTAL NUMBER OF SPACES PROVIDED IN PARKING FACILITY	MINIMUM NUMBER OF REQUIRED ACCESSIBLE SPACES
1-25	1
26-50	2
51-75	3
76-100	4
101-150	5
151-200	6
201-300	7
301-400	8
401-500	9
501-1000	2 PERCENT OF TOTAL
1001 AND OVER	20 PLUS 1 FOR EACH 100 OR FRACTION THEREOF OVER 1000

**OFF-STREET PARKING SIGNS**  
(Parking lot or garage)  
See Note 6



© 2018 California Department of Transportation  
All Rights Reserved

COUNTY ROUTE DISTRICT SHEET NO. 1105  
 REGISTERED ELECTRICAL ENGINEER  
 H. R. [Name]  
 PROFESSIONAL DESIGNER  
 No. 10150  
 EXPIRES 12-31-18  
 THE STATE OF CALIFORNIA DEPARTMENT OF TRANSPORTATION  
 REGISTERED PROFESSIONAL ENGINEER  
 No. 10150  
 EXPIRES 12-31-18  
 TO ACCOMPANY PLANS DATED \_\_\_\_\_

- NOTES:**
1. Round corners of acute angle see cuts to prevent damage to conductors.
  2. Typical distance separating loops from edge to edge is 10" for Type A, B, D, E, and F installation in single lane.
  3. Use Type D and F loops for limit line detection and bicycle lanes.

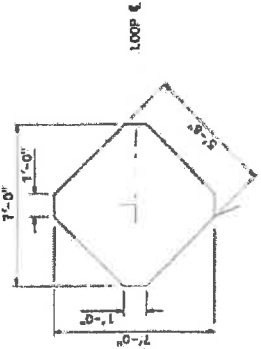

WINDING DETAIL  
TYPE B LOOP DETECTOR CONFIGURATION  
SAW CUT DETAIL

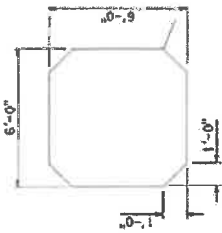
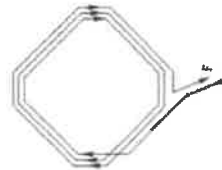

WINDING DETAIL  
TYPE A LOOP DETECTOR CONFIGURATION  
SAW CUT DETAIL

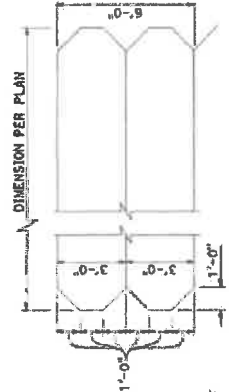
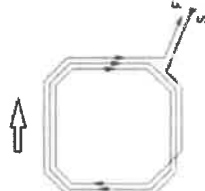

WINDING DETAIL  
TYPE C LOOP DETECTOR CONFIGURATION  
SAW CUT DETAIL

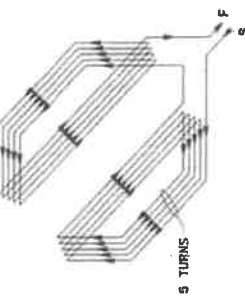
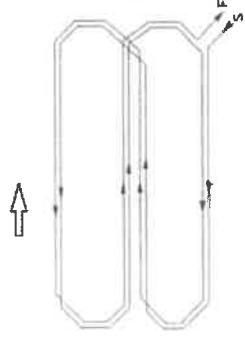

WINDING DETAIL  
TYPE D LOOP DETECTOR CONFIGURATION  
SAW CUT DETAIL

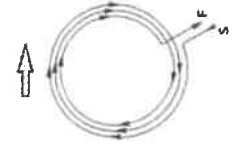
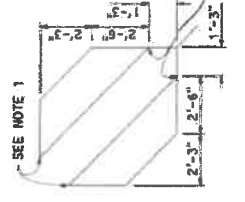

WINDING DETAIL  
TYPE E LOOP DETECTOR CONFIGURATION  
SAW CUT DETAIL

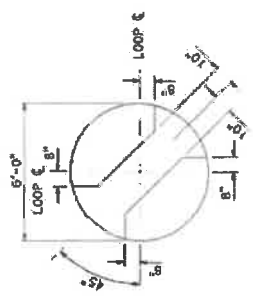
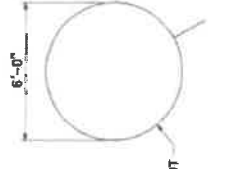

WINDING DETAIL  
TYPE F LOOP DETECTOR CONFIGURATION  
SAW CUT DETAIL

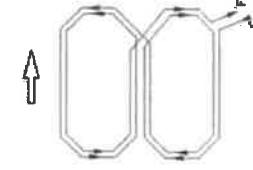
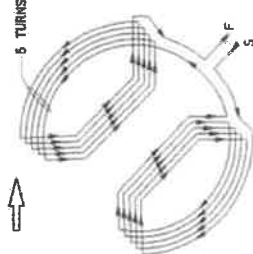

WINDING DETAIL  
TYPE Q LOOP DETECTOR CONFIGURATION  
SAW CUT DETAIL

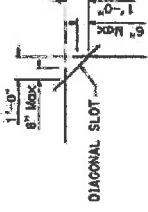
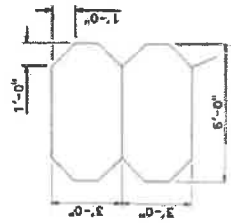

PLAN VIEW OF  
DIAGONAL SLOT  
AT CORNERS

STATE OF CALIFORNIA  
DEPARTMENT OF TRANSPORTATION  
**ELECTRICAL SYSTEMS  
(DETECTORS)**

NO SCALE

RSP ES-5B DATED OCTOBER 19, 2018 SUPERSEDES STANDARD PLAN ES-5B  
DATED MAY 31, 2018 - PAGE 505 OF THE STANDARD PLANS BOOK DATED 2018.

DISTRICT COUNTY ROUTE  
 PROJECT NO. 100-100-100-100  
 DATE 05/31/2018  
 REGISTERED CIVIL ENGINEER  
 STATE OF CALIFORNIA  
 EXPIRES 05/31/2023  
 LICENSE NO. 51333

NO PASSING ZONES-TWO DIRECTION

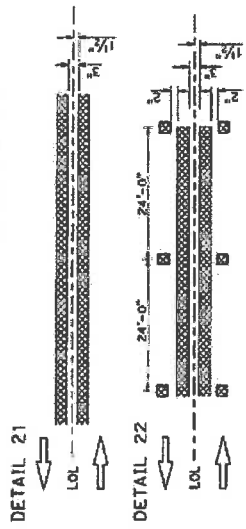

LANELINES (Cont)

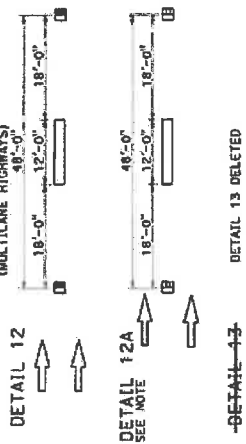

CENTERLINES

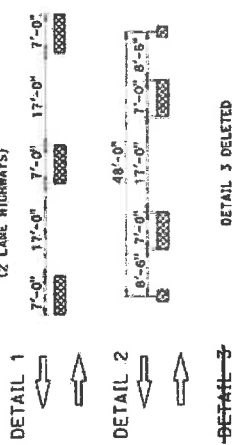

NO PASSING ZONES-ONE DIRECTION

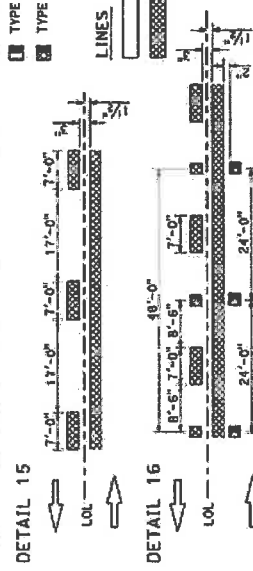

LANELINES

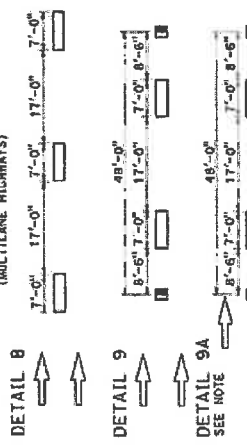

DETAIL 21

DETAIL 22

DETAIL 23 DELETED

DETAIL 12

DETAIL 12A

DETAIL 13 DELETED

DETAIL 14 DELETED

DETAIL 14A DELETED

DETAIL 3 DELETED

DETAIL 4 DELETED

DETAIL 5

DETAIL 6

DETAIL 7 DELETED

DETAIL 8

DETAIL 9

DETAIL 9A

DETAIL 10 DELETED

DETAIL 11

LEGEND

- TYPE C RED-CLEAR RETROREFLECTIVE
- TYPE D TWO-WAY YELLOW RETROREFLECTIVE
- TYPE G ONE-WAY CLEAR RETROREFLECTIVE
- TYPE H ONE-WAY YELLOW RETROREFLECTIVE

- 6" WHITE
- 6" YELLOW



TYPE C AND TYPE D TYPE G AND TYPE H

RETROREFLECTIVE FACE

STATE OF CALIFORNIA  
DEPARTMENT OF TRANSPORTATION

PAVEMENT MARKERS  
AND TRAFFIC LINES  
TYPICAL DETAILS

NO SCALE

A20A

NOTE:  
FOR FREEWAY APPLICATION ONLY

DETAIL 17 DELETED

DETAIL 18

DETAIL 19

DETAIL 20 DELETED

DIST: COUNTY: ROUTE: DISTRICT: SHEET NO. OF SHEETS  
  
 Mike Peruch  
 REGISTERED CIVIL ENGINEER  
 License No. 40042  
 State of California  
 Mechanical Engineering  
 License Expires 3-31-18  
 THE ABOVE SEAL AND INFORMATION IS VALID FOR THE STATE OF CALIFORNIA ONLY. IT IS NOT VALID FOR ANY OTHER STATE.  
 DATE: MAY 31, 2018  
 APPROVAL DATE: 5/31/18  
 FOR ANY QUESTIONS, CONTACT THE ENGINEER OR THE DESIGNER OF THIS PLAN SHEET.

**LEGEND**

**MARKERS**

- TYPE D
- TYPE H
- TYPE RY

**LINES**

- 6" WHITE
- 6" YELLOW

**INTERSECTION TREATMENTS**

- TWO-WAY YELLOW RETROREFLECTIVE
- ONE-WAY YELLOW RETROREFLECTIVE
- RED-YELLOW RETROREFLECTIVE

**MEDIAN ISLANDS**

DETAIL 28

DETAIL 29

DETAIL 30 DELETED

**LEFT EDGELINES**  
(DIVIDED HIGHWAYS)

DETAIL 24

DETAIL 25

DETAIL 25A

DETAIL 26

DETAIL 27

**INTERSECTION TREATMENTS**

DETAIL 34

DETAIL 34A

DETAIL 35

DETAIL 35A

CENTERLINE INTERSECTING STREET

**RIGHT EDGELINES**

DETAIL 27A DELETED

DETAIL 27B

DETAIL 27C

EDGE OF TRAVELED WAY

**TWO-WAY LEFT TURN LANES**

DETAIL 31

DETAIL 32

DETAIL 33 DELETED

**MARKER DETAILS**

TYPE RY AND TYPE D

TYPE H

RETROREFLECTIVE FACE

**RIGHT EDGELINE EXTENSION THROUGH INTERSECTIONS**

DETAIL 27C

STATE OF CALIFORNIA  
DEPARTMENT OF TRANSPORTATION

**PAVEMENT MARKERS AND TRAFFIC LINES TYPICAL DETAILS**

A20B

NO SCALE

© 2018 California Department of Transportation  
All Rights Reserved

DIST. COUNTY ROUTE TOTAL SHEETS SHEET NO.

REGISTERED CIVIL ENGINEER  
October 19, 2018  
PLANS APPROVAL DATE  
OF THIS STATE OF CALIFORNIA  
OF THIS STATE OF CALIFORNIA  
OF THIS STATE OF CALIFORNIA

STATE OF CALIFORNIA  
DEPARTMENT OF TRANSPORTATION  
PLANS DIVISION  
STANDARD PLAN RSP A20C  
REVISED MAY 31, 2018

**EXIT RAMP NEUTRAL AREA (GORE) TREATMENT**

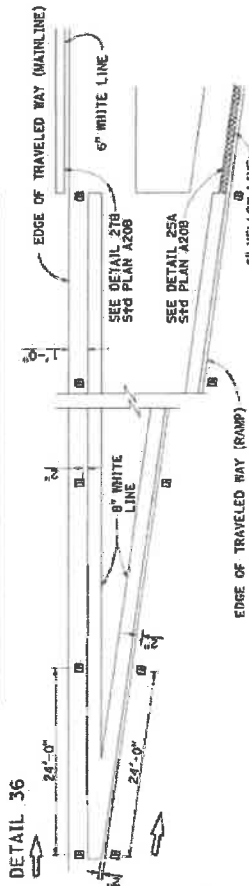

**ENTRANCE RAMP NEUTRAL AREA (MERGE) TREATMENT**

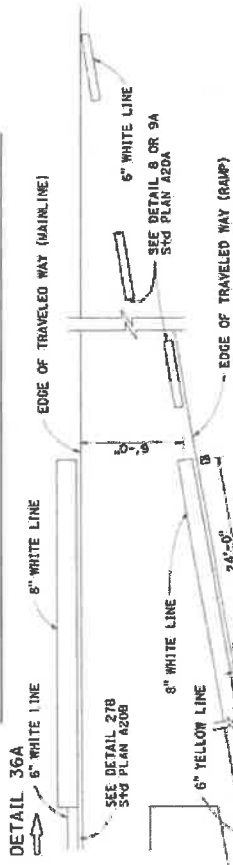

**ENTRANCE RAMP NEUTRAL AREA (ACCELERATION LANE) TREATMENT**

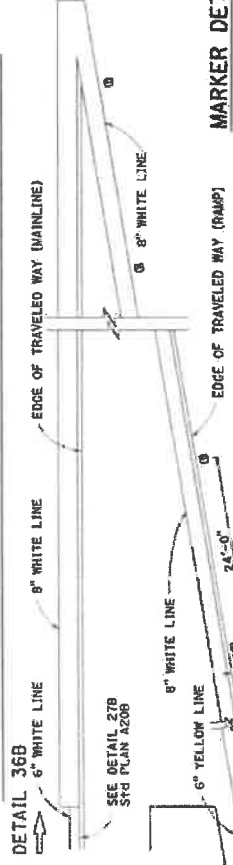

**LANE DROP AT EXIT RAMPS**

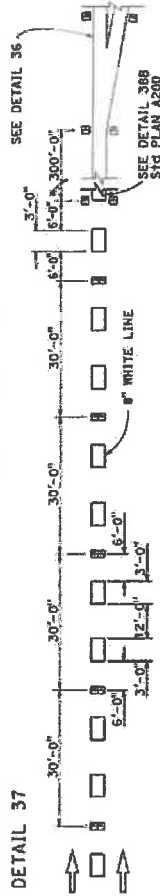

\* The solid channelizing line shown may be omitted on short auxiliary lanes where leaving length is critical.

DETAIL 37A DELETED

DETAIL 37B DELETED

**LANE DROP AT INTERSECTIONS**

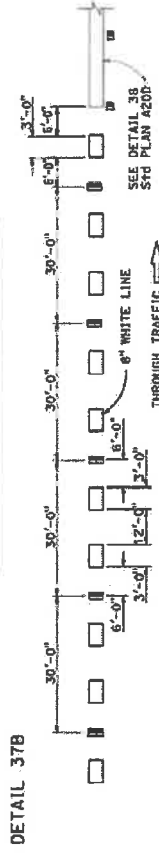

DETAIL 37A DELETED

DETAIL 37B DELETED

**MARKER DETAILS**

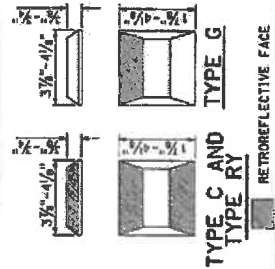

**LEGEND:**

- MARKERS
- TYPE C - CLEAR RETROREFLECTIVE
  - TYPE G - ONE-WAY CLEAR RETROREFLECTIVE
  - TYPE RY - RED-YELLOW RETROREFLECTIVE

STATE OF CALIFORNIA  
DEPARTMENT OF TRANSPORTATION  
**PAVEMENT MARKERS  
AND TRAFFIC LINES  
AND TYPICAL DETAILS**

NO SCALE

RSP A20C DATED OCTOBER 19, 2018 SUPERSEDES STANDARD PLAN A20C  
DATED MAY 31, 2018 - PAGE 14 OF THE STANDARD PLANS BOOK DATED 2018.

**REVISED STANDARD PLAN RSP A20C**

© 2018 California Department of Transportation  
All Rights Reserved

DATE: COURT: POINT: SCALE: SHEET NO. OF SHEETS

October 19, 2018  
 REGISTERED CIVIL ENGINEER  
 ALTA ENGINEERING  
 3-31-15  
 THE STATE OF CALIFORNIA (P.S. 60000)  
 OF WHICH I AM A LICENSED PROFESSIONAL ENGINEER  
 IN THE CITY AND COUNTY OF SAN DIEGO

TO ACCOMPANY PLANS DATED \_\_\_\_\_

**RECESS DETAIL FOR RETROREFLECTIVE PAVEMENT MARKER**  
 See Note 4

**SECTION B-B**  
 RETROREFLECTIVE PAVEMENT MARKER AT DOWNSTREAM END OF RECESS  
 2'-0" Min  
 1'-0" Min  
 1/2" Min

**SECTION A-A**  
 RETROREFLECTIVE PAVEMENT MARKER AT CENTER OF RECESS  
 2'-0" Min  
 1'-0" Min  
 1/2" Min

PLAN TYPE 1  
 PLAN TYPE 2

**RECESS DETAIL FOR RETROREFLECTIVE PAVEMENT MARKER**  
 See Note 4

**SECTION B-B**  
 RETROREFLECTIVE PAVEMENT MARKER AT DOWNSTREAM END OF RECESS  
 2'-0" Min  
 1'-0" Min  
 1/2" Min

**SECTION A-A**  
 RETROREFLECTIVE PAVEMENT MARKER AT CENTER OF RECESS  
 2'-0" Min  
 1'-0" Min  
 1/2" Min

PLAN TYPE 1  
 PLAN TYPE 2

**RECESS DETAIL FOR RETROREFLECTIVE PAVEMENT MARKER**  
 See Note 4

**SECTION B-B**  
 RETROREFLECTIVE PAVEMENT MARKER AT DOWNSTREAM END OF RECESS  
 2'-0" Min  
 1'-0" Min  
 1/2" Min

**SECTION A-A**  
 RETROREFLECTIVE PAVEMENT MARKER AT CENTER OF RECESS  
 2'-0" Min  
 1'-0" Min  
 1/2" Min

PLAN TYPE 1  
 PLAN TYPE 2

**RECESS DETAIL FOR RETROREFLECTIVE PAVEMENT MARKER**  
 See Note 4

**SECTION B-B**  
 RETROREFLECTIVE PAVEMENT MARKER AT DOWNSTREAM END OF RECESS  
 2'-0" Min  
 1'-0" Min  
 1/2" Min

**SECTION A-A**  
 RETROREFLECTIVE PAVEMENT MARKER AT CENTER OF RECESS  
 2'-0" Min  
 1'-0" Min  
 1/2" Min

PLAN TYPE 1  
 PLAN TYPE 2

**RECESS DETAIL FOR RETROREFLECTIVE PAVEMENT MARKER**  
 See Note 4

**SECTION B-B**  
 RETROREFLECTIVE PAVEMENT MARKER AT DOWNSTREAM END OF RECESS  
 2'-0" Min  
 1'-0" Min  
 1/2" Min

**SECTION A-A**  
 RETROREFLECTIVE PAVEMENT MARKER AT CENTER OF RECESS  
 2'-0" Min  
 1'-0" Min  
 1/2" Min

PLAN TYPE 1  
 PLAN TYPE 2

**RECESS DETAIL FOR RETROREFLECTIVE PAVEMENT MARKER**  
 See Note 4

**SECTION B-B**  
 RETROREFLECTIVE PAVEMENT MARKER AT DOWNSTREAM END OF RECESS  
 2'-0" Min  
 1'-0" Min  
 1/2" Min

**SECTION A-A**  
 RETROREFLECTIVE PAVEMENT MARKER AT CENTER OF RECESS  
 2'-0" Min  
 1'-0" Min  
 1/2" Min

PLAN TYPE 1  
 PLAN TYPE 2

**RECESS DETAIL FOR RETROREFLECTIVE PAVEMENT MARKER**  
 See Note 4

**SECTION B-B**  
 RETROREFLECTIVE PAVEMENT MARKER AT DOWNSTREAM END OF RECESS  
 2'-0" Min  
 1'-0" Min  
 1/2" Min

**SECTION A-A**  
 RETROREFLECTIVE PAVEMENT MARKER AT CENTER OF RECESS  
 2'-0" Min  
 1'-0" Min  
 1/2" Min

PLAN TYPE 1  
 PLAN TYPE 2

**RECESS DETAIL FOR RETROREFLECTIVE PAVEMENT MARKER**  
 See Note 4

**SECTION B-B**  
 RETROREFLECTIVE PAVEMENT MARKER AT DOWNSTREAM END OF RECESS  
 2'-0" Min  
 1'-0" Min  
 1/2" Min

**SECTION A-A**  
 RETROREFLECTIVE PAVEMENT MARKER AT CENTER OF RECESS  
 2'-0" Min  
 1'-0" Min  
 1/2" Min

PLAN TYPE 1  
 PLAN TYPE 2

**RECESS DETAIL FOR RETROREFLECTIVE PAVEMENT MARKER**  
 See Note 4

**SECTION B-B**  
 RETROREFLECTIVE PAVEMENT MARKER AT DOWNSTREAM END OF RECESS  
 2'-0" Min  
 1'-0" Min  
 1/2" Min

**SECTION A-A**  
 RETROREFLECTIVE PAVEMENT MARKER AT CENTER OF RECESS  
 2'-0" Min  
 1'-0" Min  
 1/2" Min

PLAN TYPE 1  
 PLAN TYPE 2

**RECESS DETAIL FOR RETROREFLECTIVE PAVEMENT MARKER**  
 See Note 4

**SECTION B-B**  
 RETROREFLECTIVE PAVEMENT MARKER AT DOWNSTREAM END OF RECESS  
 2'-0" Min  
 1'-0" Min  
 1/2" Min

**SECTION A-A**  
 RETROREFLECTIVE PAVEMENT MARKER AT CENTER OF RECESS  
 2'-0" Min  
 1'-0" Min  
 1/2" Min

PLAN TYPE 1  
 PLAN TYPE 2

**RECESS DETAIL FOR RETROREFLECTIVE PAVEMENT MARKER**  
 See Note 4

**SECTION B-B**  
 RETROREFLECTIVE PAVEMENT MARKER AT DOWNSTREAM END OF RECESS  
 2'-0" Min  
 1'-0" Min  
 1/2" Min

**SECTION A-A**  
 RETROREFLECTIVE PAVEMENT MARKER AT CENTER OF RECESS  
 2'-0" Min  
 1'-0" Min  
 1/2" Min

PLAN TYPE 1  
 PLAN TYPE 2

**RECESS DETAIL FOR RETROREFLECTIVE PAVEMENT MARKER**  
 See Note 4

**SECTION B-B**  
 RETROREFLECTIVE PAVEMENT MARKER AT DOWNSTREAM END OF RECESS  
 2'-0" Min  
 1'-0" Min  
 1/2" Min

**SECTION A-A**  
 RETROREFLECTIVE PAVEMENT MARKER AT CENTER OF RECESS  
 2'-0" Min  
 1'-0" Min  
 1/2" Min

PLAN TYPE 1  
 PLAN TYPE 2

**RECESS DETAIL FOR RETROREFLECTIVE PAVEMENT MARKER**  
 See Note 4

**SECTION B-B**  
 RETROREFLECTIVE PAVEMENT MARKER AT DOWNSTREAM END OF RECESS  
 2'-0" Min  
 1'-0" Min  
 1/2" Min

**SECTION A-A**  
 RETROREFLECTIVE PAVEMENT MARKER AT CENTER OF RECESS  
 2'-0" Min  
 1'-0" Min  
 1/2" Min

PLAN TYPE 1  
 PLAN TYPE 2

**RECESS DETAIL FOR RETROREFLECTIVE PAVEMENT MARKER**  
 See Note 4

**SECTION B-B**  
 RETROREFLECTIVE PAVEMENT MARKER AT DOWNSTREAM END OF RECESS  
 2'-0" Min  
 1'-0" Min  
 1/2" Min

**SECTION A-A**  
 RETROREFLECTIVE PAVEMENT MARKER AT CENTER OF RECESS  
 2'-0" Min  
 1'-0" Min  
 1/2" Min

PLAN TYPE 1  
 PLAN TYPE 2

**RECESS DETAIL FOR RETROREFLECTIVE PAVEMENT MARKER**  
 See Note 4

**SECTION B-B**  
 RETROREFLECTIVE PAVEMENT MARKER AT DOWNSTREAM END OF RECESS  
 2'-0" Min  
 1'-0" Min  
 1/2" Min

**SECTION A-A**  
 RETROREFLECTIVE PAVEMENT MARKER AT CENTER OF RECESS  
 2'-0" Min  
 1'-0" Min  
 1/2" Min

PLAN TYPE 1  
 PLAN TYPE 2

**RECESS DETAIL FOR RETROREFLECTIVE PAVEMENT MARKER**  
 See Note 4

**SECTION B-B**  
 RETROREFLECTIVE PAVEMENT MARKER AT DOWNSTREAM END OF RECESS  
 2'-0" Min  
 1'-0" Min  
 1/2" Min

**SECTION A-A**  
 RETROREFLECTIVE PAVEMENT MARKER AT CENTER OF RECESS  
 2'-0" Min  
 1'-0" Min  
 1/2" Min

PLAN TYPE 1  
 PLAN TYPE 2

**RECESS DETAIL FOR RETROREFLECTIVE PAVEMENT MARKER**  
 See Note 4

**SECTION B-B**  
 RETROREFLECTIVE PAVEMENT MARKER AT DOWNSTREAM END OF RECESS  
 2'-0" Min  
 1'-0" Min  
 1/2" Min

**SECTION A-A**  
 RETROREFLECTIVE PAVEMENT MARKER AT CENTER OF RECESS  
 2'-0" Min  
 1'-0" Min  
 1/2" Min

PLAN TYPE 1  
 PLAN TYPE 2

**RECESS DETAIL FOR RETROREFLECTIVE PAVEMENT MARKER**  
 See Note 4

**SECTION B-B**  
 RETROREFLECTIVE PAVEMENT MARKER AT DOWNSTREAM END OF RECESS  
 2'-0" Min  
 1'-0" Min  
 1/2" Min

**SECTION A-A**  
 RETROREFLECTIVE PAVEMENT MARKER AT CENTER OF RECESS  
 2'-0" Min  
 1'-0" Min  
 1/2" Min

PLAN TYPE 1  
 PLAN TYPE 2

**RECESS DETAIL FOR RETROREFLECTIVE PAVEMENT MARKER**  
 See Note 4

**SECTION B-B**  
 RETROREFLECTIVE PAVEMENT MARKER AT DOWNSTREAM END OF RECESS  
 2'-0" Min  
 1'-0" Min  
 1/2" Min

**SECTION A-A**  
 RETROREFLECTIVE PAVEMENT MARKER AT CENTER OF RECESS  
 2'-0" Min  
 1'-0" Min  
 1/2" Min

PLAN TYPE 1  
 PLAN TYPE 2

**RECESS DETAIL FOR RETROREFLECTIVE PAVEMENT MARKER**  
 See Note 4

**SECTION B-B**  
 RETROREFLECTIVE PAVEMENT MARKER AT DOWNSTREAM END OF RECESS  
 2'-0" Min  
 1'-0" Min  
 1/2" Min

**SECTION A-A**  
 RETROREFLECTIVE PAVEMENT MARKER AT CENTER OF RECESS  
 2'-0" Min  
 1'-0" Min  
 1/2" Min

PLAN TYPE 1  
 PLAN TYPE 2

**RECESS DETAIL FOR RETROREFLECTIVE PAVEMENT MARKER**  
 See Note 4

**SECTION B-B**  
 RETROREFLECTIVE PAVEMENT MARKER AT DOWNSTREAM END OF RECESS  
 2'-0" Min  
 1'-0" Min  
 1/2" Min

**SECTION A-A**  
 RETROREFLECTIVE PAVEMENT MARKER AT CENTER OF RECESS  
 2'-0" Min  
 1'-0" Min  
 1/2" Min

PLAN TYPE 1  
 PLAN TYPE 2

**RECESS DETAIL FOR RETROREFLECTIVE PAVEMENT MARKER**  
 See Note 4

**SECTION B-B**  
 RETROREFLECTIVE PAVEMENT MARKER AT DOWNSTREAM END OF RECESS  
 2'-0" Min  
 1'-0" Min  
 1/2" Min

**SECTION A-A**  
 RETROREFLECTIVE PAVEMENT MARKER AT CENTER OF RECESS  
 2'-0" Min  
 1'-0" Min  
 1/2" Min

PLAN TYPE 1  
 PLAN TYPE 2

**RECESS DETAIL FOR RETROREFLECTIVE PAVEMENT MARKER**  
 See Note 4

**SECTION B-B**  
 RETROREFLECTIVE PAVEMENT MARKER AT DOWNSTREAM END OF RECESS  
 2'-0" Min  
 1'-0" Min  
 1/2" Min

**SECTION A-A**  
 RETROREFLECTIVE PAVEMENT MARKER AT CENTER OF RECESS  
 2'-0" Min  
 1'-0" Min  
 1/2" Min

PLAN TYPE 1  
 PLAN TYPE 2

**RECESSED MARKER NOTES:**

- See typical traffic line details for marker patterns to be used with recessed pavement markers.
- The retroreflective pavement markers shown for recessed installations are not to be used for non-recessed installations.
- The top of pavement markers installed in recesses shall be 0 to 1/8" below the pavement surface.
- Use Type 1 recess for pavement markers with one-way retroreflective face. Use Type 2 recess for pavement markers with two-way retroreflective face.

STATE OF CALIFORNIA  
 DEPARTMENT OF TRANSPORTATION

**PAVEMENT MARKERS AND TRAFFIC LINES TYPICAL DETAILS**

NO SCALE

REP A20D DATED OCTOBER 19, 2018, SUPERSEDES STANDARD PLAN A20D DATED MAY 31, 2016 - PAGE 15 OF THE STANDARD PLANS BOOK DATED 2016.

**REVISED STANDARD PLAN RSP A20D**

**MARKER DETAILS**

TYPE C RED-CLEAR RETROREFLECTIVE  
 TYPE G ONE-WAY CLEAR RETROREFLECTIVE  
 6" YELLOW LINE

TYPE C  
 TYPE G

3 3/8" - 4 1/8"  
 1 1/2" - 4 1/8"

RETROREFLECTIVE FACE

**DETAIL FOR RECESSED TRAFFIC STRIPE**  
 See Notes A and B.

FINISHED ROADWAY SURFACE  
 FINISHED ROUGHEN SURFACE  
 STRIPING MATERIAL  
 6" TO 8"

RECESSED TRAFFIC STRIPE

**RECESSED TRAFFIC STRIPE**  
 See Notes A and B.

FINISHED ROADWAY SURFACE  
 FINISHED ROUGHEN SURFACE  
 STRIPING MATERIAL  
 6" TO 8"

RECESSED TRAFFIC STRIPE

**RECESSED TRAFFIC STRIPE**  
 See Notes A and B.

FINISHED ROADWAY SURFACE  
 FINISHED ROUGHEN SURFACE  
 STRIPING MATERIAL  
 6" TO 8"

RECESSED TRAFFIC STRIPE

**RECESSED TRAFFIC STRIPE**  
 See Notes A and B.

FINISHED ROADWAY SURFACE  
 FINISHED ROUGHEN SURFACE  
 STRIPING MATERIAL  
 6" TO 8"

RECESSED TRAFFIC STRIPE

**RECESSED TRAFFIC STRIPE**  
 See Notes A and B.

FINISHED ROADWAY SURFACE  
 FINISHED ROUGHEN SURFACE  
 STRIPING MATERIAL  
 6" TO 8"

RECESSED TRAFFIC STRIPE

**RECESSED TRAFFIC STRIPE**  
 See Notes A and B.

FINISHED ROADWAY SURFACE  
 FINISHED ROUGHEN SURFACE  
 STRIPING MATERIAL  
 6" TO 8"

RECESSED TRAFFIC STRIPE

**RECESSED TRAFFIC STRIPE**  
 See Notes A and B.

FINISHED ROADWAY SURFACE  
 FINISHED ROUGHEN SURFACE  
 STRIPING MATERIAL  
 6" TO 8"

RECESSED TRAFFIC STRIPE

DIST COUNTY ROUTE TOTAL PROJECT NO. SHEETS

REGISTERED CIVIL ENGINEER  
*Oliver Fenn*  
 MAY 31 2018  
 PLANS APPROVAL DATE  
 THE STATE OF CALIFORNIA BY ITS OFFICERS  
 OF PUBLIC WORKS HAS REVIEWED THIS  
 PLAN AND HAS FOUND IT TO BE IN ACCORDANCE WITH  
 THE REQUIREMENTS OF THE PUBLIC WORKS ACT OF 1907.

REGISTERED PROFESSIONAL ENGINEER  
 CIVIL ENGINEER  
 No. 32119  
 STATE OF CALIFORNIA

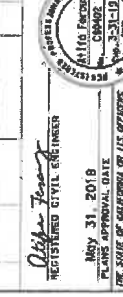

A=33 f12  
**TYPE V ARROW**

STATE OF CALIFORNIA  
 DEPARTMENT OF TRANSPORTATION  
**PAVEMENT MARKINGS  
 ARROWS**  
 NO SCALE

A24A

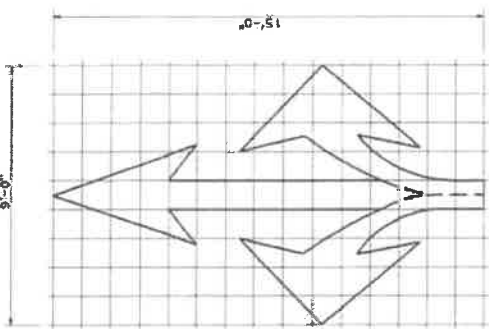

A=26 f12  
**TYPE VIII ARROW**

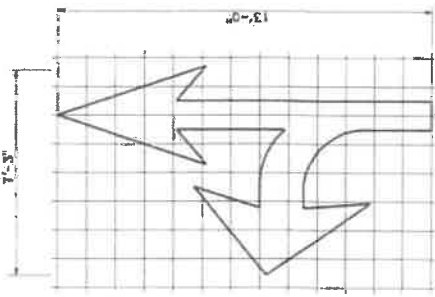

A=27 f12  
**TYPE VII (L) ARROW**  
 (For Type VII (R) arrows,  
 use mirror image)

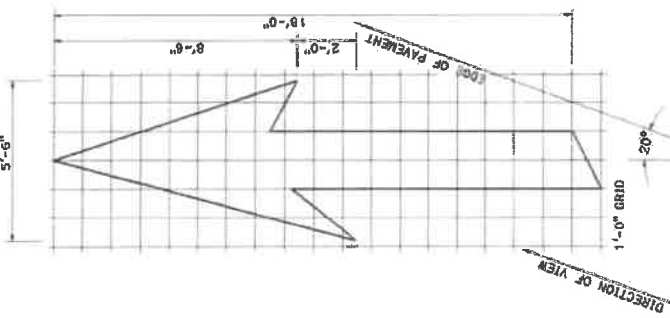

A=42 f12  
**TYPE VI ARROW**  
 Right lane drop arrow  
 (For left lanes,  
 use mirror image)

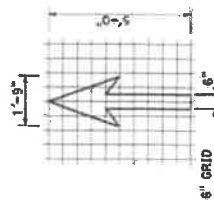

A=3.5 f12  
**BIKE LANE ARROW**

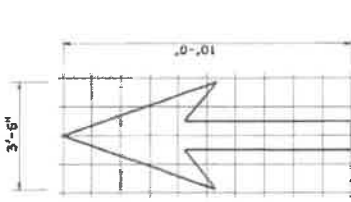

A=14 f12  
**TYPE I 10'-0" ARROW**

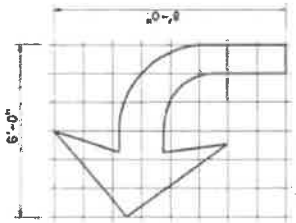

A=15 f12  
**TYPE IV (L) ARROW**  
 (For Type IV (R) arrows,  
 use mirror image)

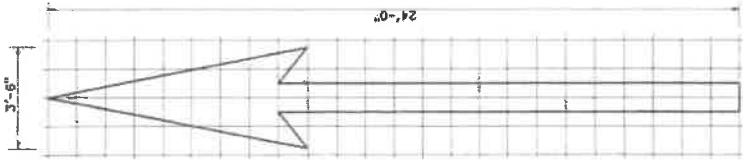

A=31 f12  
**TYPE I 24'-0" ARROW**

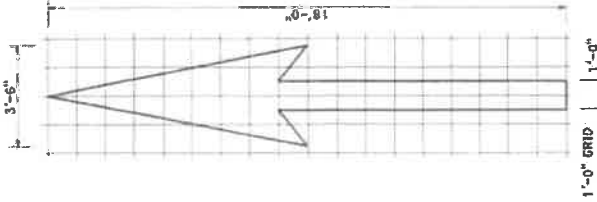

A=25 f12  
**TYPE I 18'-0" ARROW**

NOTE:  
 Minor variations in dimensions  
 may be accepted by the Engineer.



DISTRICT COUNTY ROUTE TOTAL MILES NO. SHEETS  
 REGISTERED CIVIL ENGINEER  
 May 31, 2018  
 ALL RIGHTS RESERVED  
 THE STATE OF CALIFORNIA  
 DEPARTMENT OF TRANSPORTATION  
 DIVISION OF HIGHWAYS  
 CONTRACT NO. 13-0000000000000000  
 SHEET NO. 13-0000000000000000  
 DATE OF ISSUE 05/31/18  
 DATE OF PREVIOUS EDITION 05/31/18  
 THIS DRAWING IS THE PROPERTY OF THE STATE OF CALIFORNIA AND IS TO BE USED ONLY FOR THE PROJECT AND LOCATION SPECIFIED ON THIS PLAN SHEET.

NOTE:  
Minor variations in dimensions may be accepted by the Engineer.

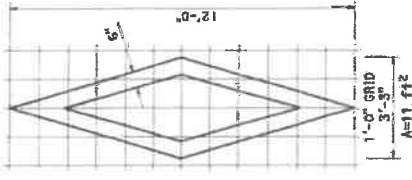

**DIAMOND SYMBOL**

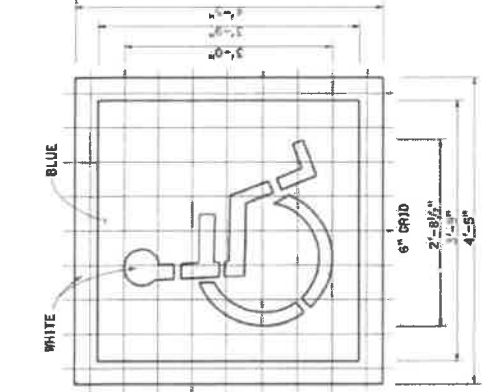

**INTERNATIONAL SYMBOL OF ACCESSIBILITY (ISA) MARKING**

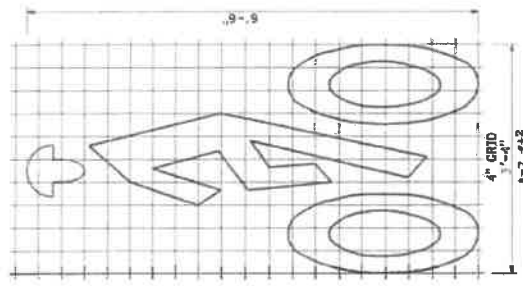

**BIKE LANE SYMBOL WITH PERSON**

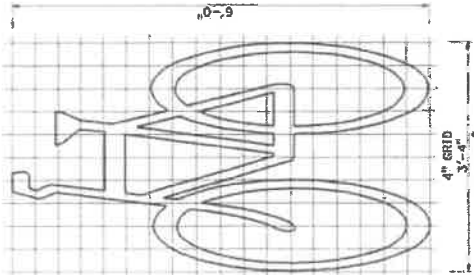

**BIKE LANE SYMBOL WITHOUT PERSON**

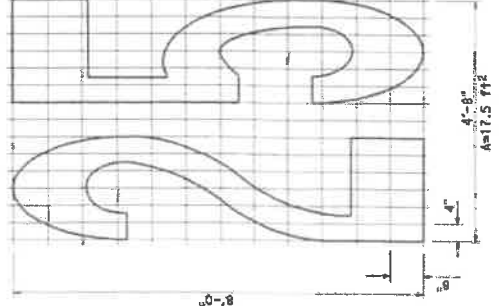
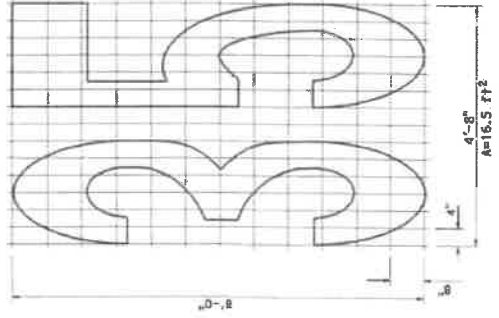
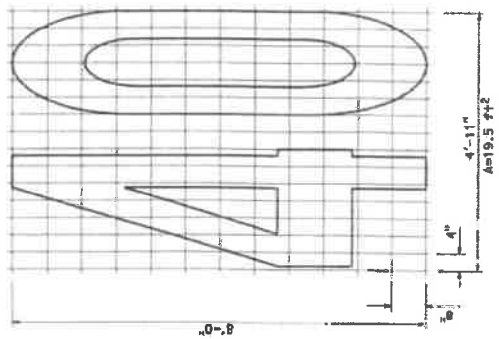

**NUMERALS**

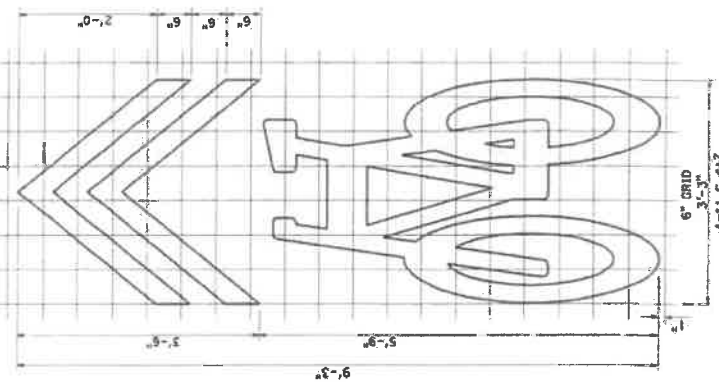

**SHARED ROADWAY BICYCLE MARKING**

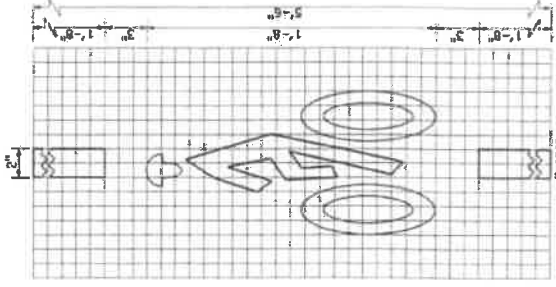

**BICYCLE LOOP DETECTOR SYMBOL**

STATE OF CALIFORNIA  
DEPARTMENT OF TRANSPORTATION

**PAVEMENT MARKINGS SYMBOLS AND NUMERALS**

NO SCALE

**A24C**

DIST COUNTY ROUTE TOTAL PROJECT SHEET NO. 1 OF 1

*Chetan Jeyaraj*  
REGISTERED CIVIL ENGINEER

May 31, 2018  
ISSUANCE DATE

THE STATE OF CALIFORNIA  
THE ABOVE SHALL NOT BE RESPONSIBLE FOR  
CONTRACTS OR THAT PLAN SHEETS.

REGISTERED CIVIL ENGINEER  
MILITARY SERVICE  
NO. 2-31-19  
EXPIRES

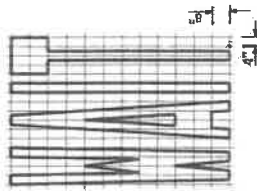

A=19 ft+2

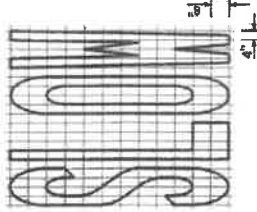

A=23 ft+2

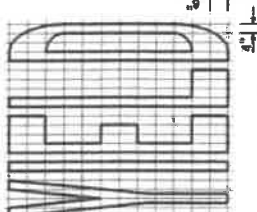

A=24 ft+2

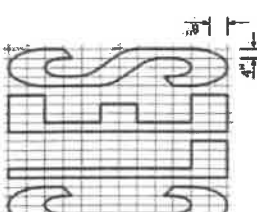

A=42 ft+2

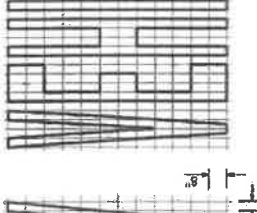

A=31 ft+2

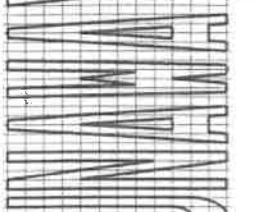

A=19 ft+2

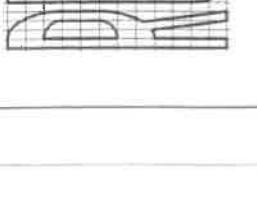

A=18 ft+2

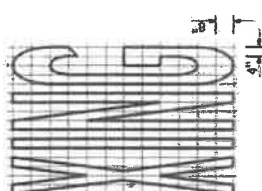

A=21 ft+2



A=26 ft+2

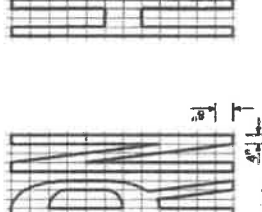

A=24 ft+2

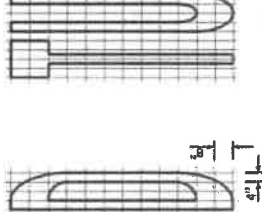

A=22 ft+2

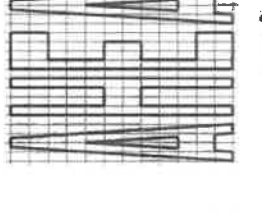

A=6 ft+2

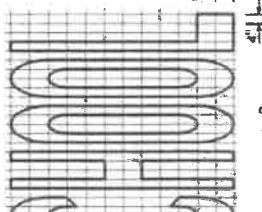

A=5 ft+2

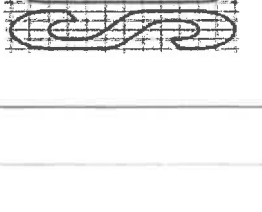

A=35 ft+2

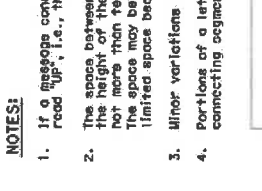

A=32 ft+2

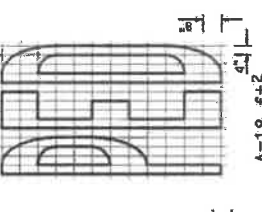

A=19 ft+2

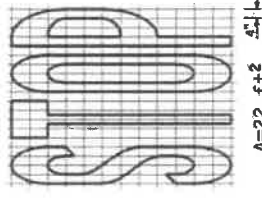

A=18 ft+2

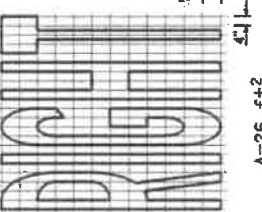

A=10 ft+2

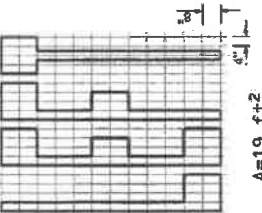

A=26 ft+2

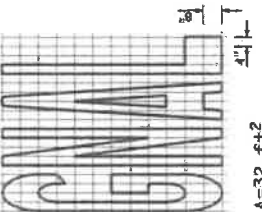

A=42 ft+2

WORD MARKINGS

ITEM	ft+2	ITEM	ft+2	ITEM	ft+2
XING	23	YIELD	24	BIKE	5
AHEAD	31	SCHOOL	35	SLOW	23
WAIT	19	SIGNAL	32	STOP	22
LANE	6	TURB.	24	LEFT	19
RIGHT	26	HERE	26	VEHICLES	42

- NOTES:
- If a message consists of more than one word, it must read "UP, I.e., the first word must be nearest the driver.
  - The space between words must be at least four times the height of the characters for low speed roads, but not more than ten times the height of the characters. The space may be reduced appropriately where there is limited space because of local conditions.
  - Minor variations in dimensions may be accepted by the Engineer.
  - Portions of a letter, number or symbol may be separated by connecting segments not to exceed 2" in width.

STATE OF CALIFORNIA  
DEPARTMENT OF TRANSPORTATION  
**PAVEMENT MARKINGS  
WORDS**  
NO SCALE

A24D

DIST. COUNTY ROUTE TOTAL SHEETS NO. SHEETS

*Oliver Farnsworth*  
REGISTERED CIVIL ENGINEER

October 19, 2018  
PLANS APPROVAL DATE

REGISTERED PROFESSIONAL ENGINEER IN THE STATE OF CALIFORNIA  
No. 51667  
EXPIRES 10/19/21

THIS PLAN WAS PREPARED BY ME OR UNDER MY CLOSE PERSONAL SUPERVISION AND I AM A QUALIFIED PROFESSIONAL ENGINEER IN THE STATE OF CALIFORNIA.  
I HEREBY CERTIFY THAT I AM A QUALIFIED PROFESSIONAL ENGINEER IN THE STATE OF CALIFORNIA.  
I HEREBY CERTIFY THAT I AM A QUALIFIED PROFESSIONAL ENGINEER IN THE STATE OF CALIFORNIA.

TO ACCOMPANY PLANS DATED

ITEM	FT.	ITEM	FT.
LANE	24	NO	14
POOL	23	BIKE	21
CAR	17	BUS	20
CLEAR	27	ONLY	22
KEEP	24	FWY	16
HOV	18	EXPRS	30
TRAIL	23		

NOTES:

- If a message consists of more than one word, it must read as one word, i.e., the first word must be nearest the driver.
- The space between words must be at least four times the height of the characters for the first word and at least three times the height of the characters for the second word. The height of the characters must be reduced appropriately where there is limited space because of local conditions.
- Minor variations in dimensions may be accepted by the Engineer.
- Portions of a letter, number or symbol may be expected by adjoining segments not to be expected.
- The word "NO PARKING" is to be used in all locations of markings, see Standard Plans A90A and A90B.
- The words "NO PARKING" shall be printed in white letters no less than 1/2" high on 1/2" high background. The background color shall be visible to traffic enforcement officials.

STATE OF CALIFORNIA  
DEPARTMENT OF TRANSPORTATION

**PAVEMENT MARKINGS  
WORDS**

NO SCALE

REP A24E DATED OCTOBER 19, 2018 SUPERSEDES STANDARD PLAN A24E  
DATED MAY 31, 2018 - PAGE 21 OF THE STANDARD PLANS BOOK DATED 2018.

**REVISED STANDARD PLAN RSP A24E**

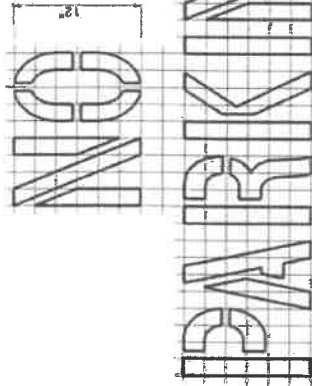
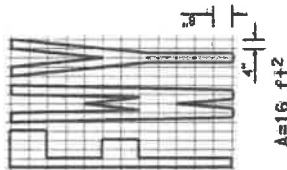
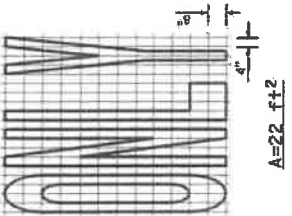
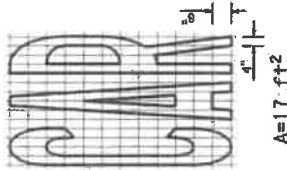
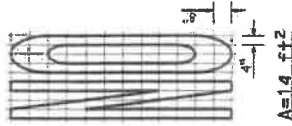

See Notes 5 and 6

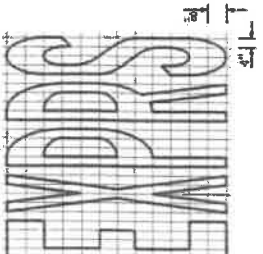
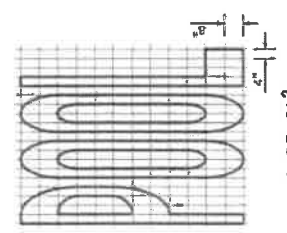
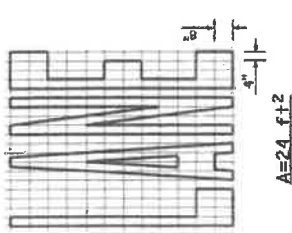
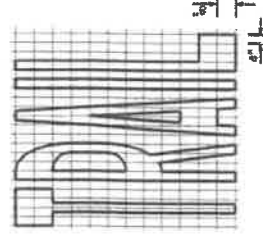
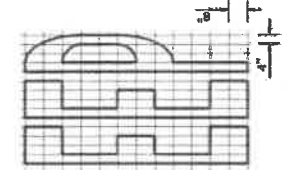
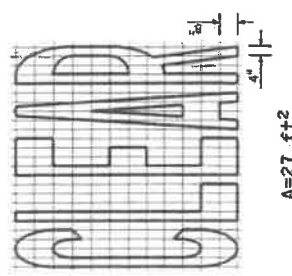
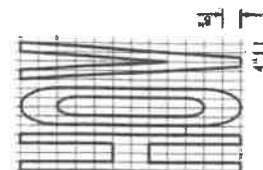
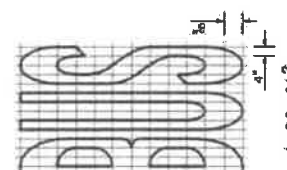
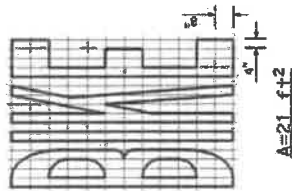

## **APPENDIX “C”**

### **STREET CROSS SECTIONS**

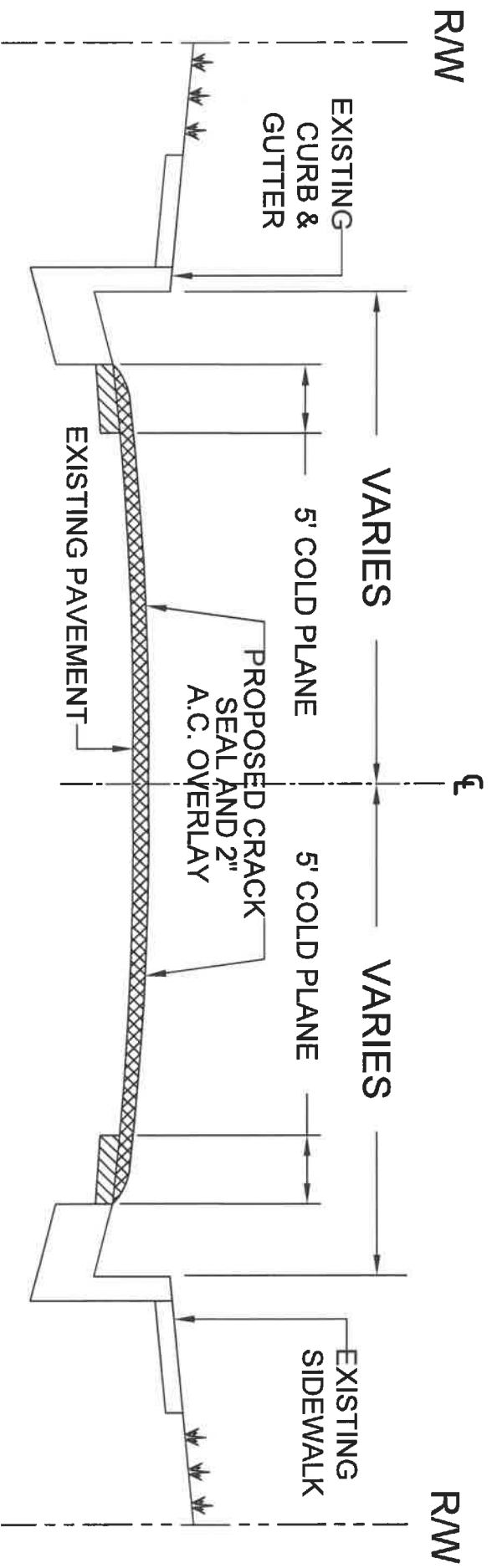

**TYPICAL CROSS SECTION "A"**  
**NOT TO SCALE**

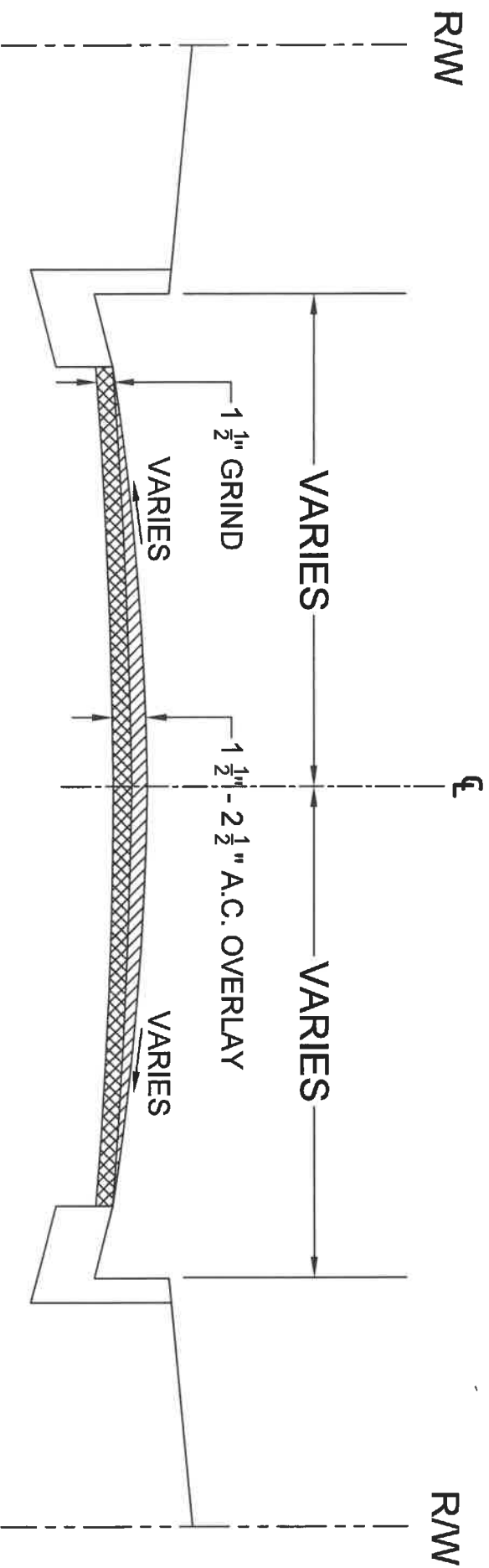

TYPICAL CROSS SECTION "B"  
 NOT TO SCALE

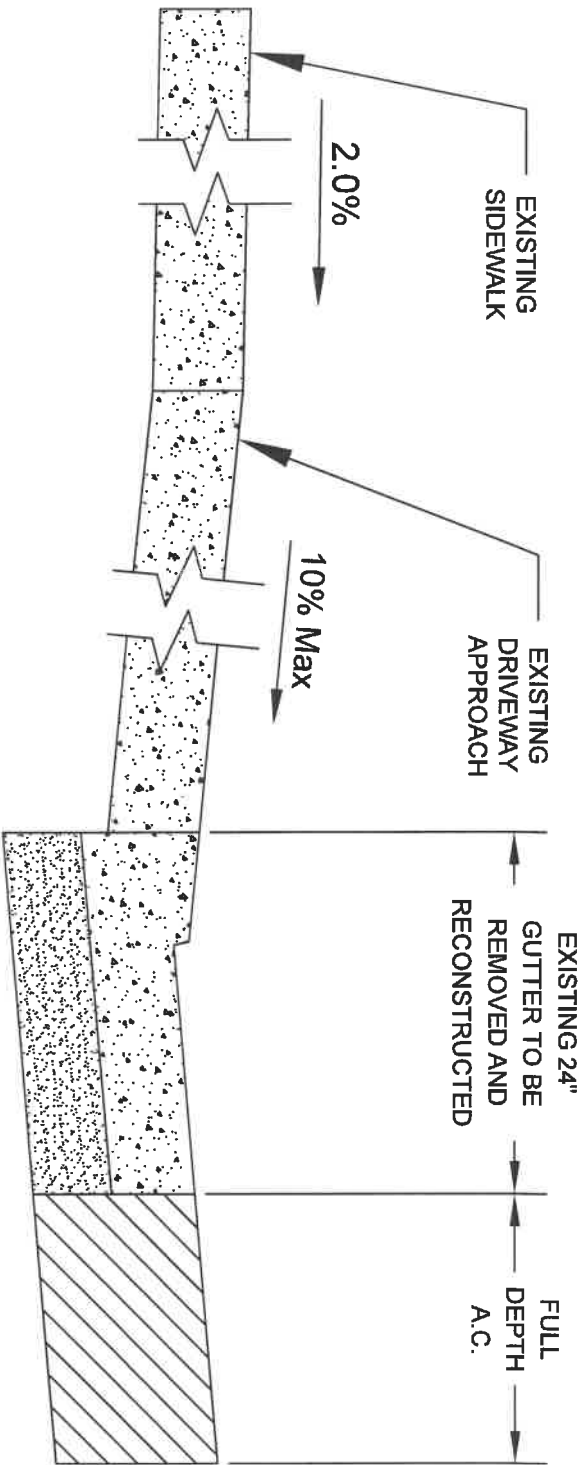

**TYPICAL 24" GUTTER REPLACEMENT**  
**NOT TO SCALE**

## **APENDIX “D”**

### **SPEED LUMP DETAIL**

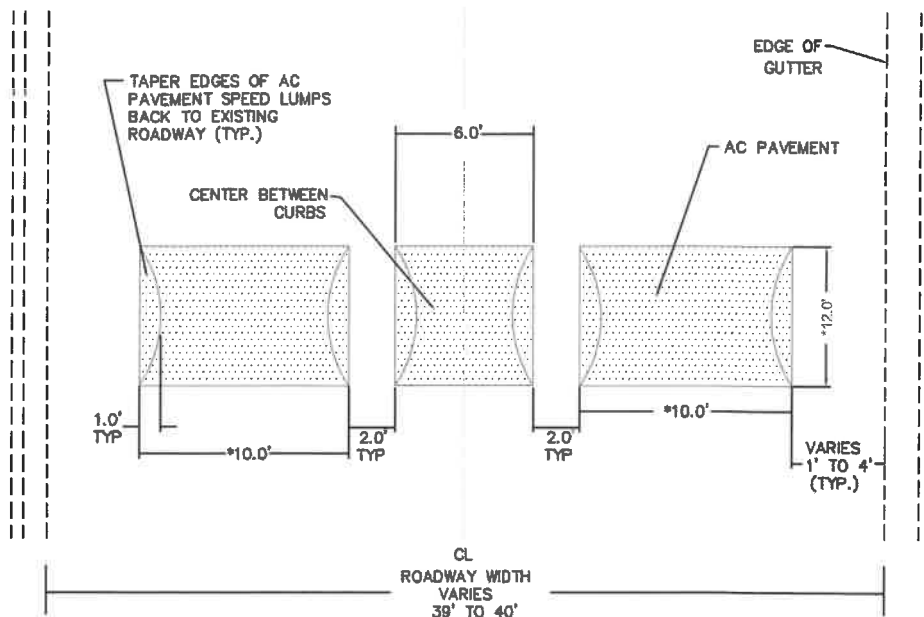

**SPEED LUMP LAYOUT DETAIL**

NOT TO SCALE  
 EXACT LOCATION TO BE DETERMINED BY THE ENGINEER AT THE TIME OF CONSTRUCTION

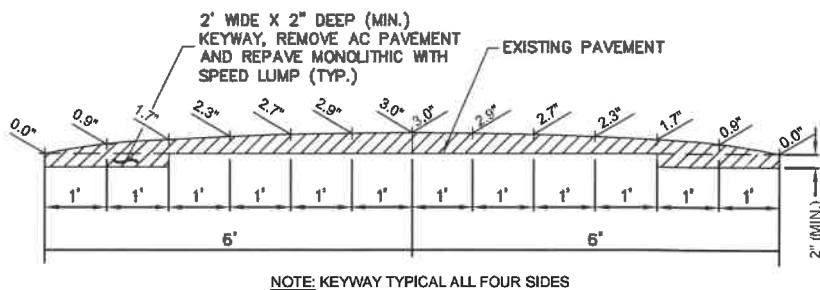

NOTE: KEYWAY TYPICAL ALL FOUR SIDES

**PARABOLIC CROSS SECTION FOR AC PAVEMENT SPEED LUMP**

NOT TO SCALE

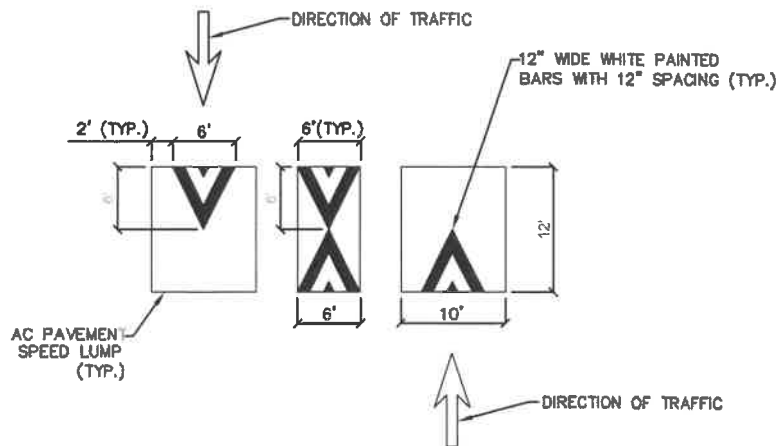

**SPEED LUMP DETAIL**

NTS