

**CITY OF LA HABRA
PUBLIC WORKS AGREEMENT FOR
HELI-HYDRANT PROJECT, CITY PROJECT NO. 1-W-23**

THIS AGREEMENT (herein "Agreement"), is made and entered into this 21st day of November, 2022, between the CITY OF LA HABRA, a municipal corporation (herein "City") and Glenn Chavez Construction (herein "Contractor"). The parties hereto agree as follows:

W I T N E S S E T H :

A. WHEREAS, City requires the construction of Heli-Hydrant Project, City Project No. 1-W-23, improvements as set forth more fully in this Agreement.

B. WHEREAS, Contractor represents to City that Contractor is qualified to perform said work and has submitted a proposal to City for the same.

C. WHEREAS, City desires to have Contractor perform said services on the terms and conditions set forth herein.

D. WHEREAS, no official or employee of City has a financial interest, within the provisions of Sections 1090-1092 of the California Government Code, in the subject matter of this Agreement.

NOW, THEREFORE, for and in consideration of the mutual covenants and conditions contained herein and for good and valuable consideration, the receipt and sufficiency of which is acknowledged by both parties, City and Contractor hereby agree as follows:

1.0 DEFINITIONS

1.1 Definitions. As used in this Agreement, the following definitions shall be applicable:

- (a) Contractor. Contractor shall mean (Glenn Chavez Construction), a California contractor located at 460 W Lambert Rd #k Brea Ca. 92821
- (b) City. City shall mean the City of La Habra, a Municipal Corporation and Charter City, located at 110 E. La Habra Blvd, La Habra, California 90631.
- (c) City Council. City Council shall mean the City Council of the City of La Habra.
- (d) Contract Officer shall mean the person designated by the City Administrator or City Engineer of City and shall have the duties set forth in Section 5.2.

- (e) **Services.** Services shall mean the services to be performed by the Contractor pursuant to this Agreement.
- (f) **Satisfactory.** Satisfactory shall mean satisfactory to the City Administrator or his/her designee.

2.0 SERVICES OF CONTRACTOR

2.1 Scope of Services. In compliance with all terms and conditions of this Agreement, the Contractor shall provide those services specified in the "Scope of Services" attached hereto as Exhibit "A" and incorporated herein by this reference, which services may be referred to herein as the "services" or "work" hereunder. As a material inducement to the City entering into this Agreement, Contractor represents and warrants that Contractor is a provider of first class work and services and Contractor is experienced in performing the work and services contemplated herein and, in light of such status and experience, Contractor covenants that it shall follow the highest professional standards in performing the work and services required hereunder and that all materials will be of good quality, fit for the purpose intended.

2.2 Documents Included in Contract. This contract consists of this Agreement and any Exhibits, which are incorporated herein by this reference. In the event of an inconsistency, the terms of this Agreement shall govern.

2.3 Compliance with Law. All services rendered hereunder shall be provided in accordance with all ordinances, resolutions, statutes, rules, and regulations of the City and any Federal, State or local governmental agency having jurisdiction in effect at the time service is rendered, including but not limited to, the claims procedure set forth in Public Contract Code Section 9204, a summary of which is attached to this agreement as Exhibit "D."

2.4 Licenses, Permits, Fees and Assessments. Contractor shall obtain at its sole cost and expense such licenses, permits and approvals as may be required by law for the performance of the services required by this Agreement, including registration with the Department of Industrial Relations of the State of California as required by Labor Code Section 1725.5 before commencing performance under this Agreement. Contractor shall have the sole obligation to pay for any fees, assessments and taxes, plus applicable penalties and interest, which may be imposed by law and arise from or are necessary for the Contractor's performance of the services required by this Agreement, and shall indemnify, defend and hold harmless City against any such fees, assessments, taxes penalties or interest levied, assessed or imposed against City hereunder. Contractor shall be responsible for all subcontractors' compliance with this Section 2.4.

2.5 Familiarity with Work. By executing this Contract, Contractor warrants that Contractor (a) has thoroughly investigated and considered the scope of services to be performed, (b) has carefully considered how the services should be performed, and (c) fully understands the facilities, difficulties and restrictions attending performance of the services under this Agreement. If the services involve work upon any site, Contractor warrants that Contractor has or will investigate the site and is or will be fully acquainted with the conditions there existing, prior to commencement of services hereunder. Should Contractor discover any latent or unknown conditions, which will materially affect the performance of the services hereunder, Contractor shall immediately inform the City of such fact and shall not proceed except at Contractor's risk until written instructions are received from the Contract Officer.

2.6 Standard of Performance. Contractor, its subcontractors and their employees, in the performance of Contractor's work under this Agreement shall be responsible for exercising the degree of skill and care required by customarily accepted good professional practices and procedures used in the Contractor's field.

Any costs for failure to meet the foregoing standard or to correct otherwise defective work that requires re-performance of the work, shall be borne in total by the Contractor and not by the City. The failure of a project to achieve the performance goals and objectives stated in this Agreement is not a basis for requesting re-performance unless the work conducted by Contractor and/or its subcontractors is deemed by the City to have failed the foregoing standard of performance.

In the event Contractor fails to perform in accordance with the above standard:

1. Contractor will re-perform, at its own expense, any task which was not performed to the reasonable satisfaction of City. Any work re-performed pursuant to this paragraph shall be completed within the time limitations originally set forth for the specific task involved. Contractor shall work any overtime required to meet the deadline for the task at no additional cost to the City;
2. The City shall provide a new schedule for the re-performance of any task pursuant to this paragraph in the event that re-performance of a task within the original time limitations is not feasible; and
3. The City shall have the option to direct Contractor not to re-perform any task which was not performed to the reasonable satisfaction of the City Project Manager pursuant to application of (1) and (2) above. In the event the City directs Contractor not to re-perform a task, the City shall negotiate a reasonable settlement for satisfactory work performed. No previous payment shall be considered a waiver of the City's right to reimbursement.

Nothing contained in this section is intended to limit any of the rights or remedies which the City may have under law.

2.7 Care of Work. The Contractor shall adopt reasonable methods during the life of the Agreement to furnish continuous protection to the work, and the equipment, materials, papers, documents, plans, studies and/or other components thereof to prevent losses or damages, and shall be responsible for all such damages, to persons or property, until acceptance of the work by City, except such losses or damages as may be caused by City's own negligence.

2.8 Further Responsibilities of Parties. Both parties agree to use reasonable care and diligence to perform their respective obligations under this Agreement. Both parties agree to act in good faith to execute all instruments, prepare all documents and take all actions as may be reasonably necessary to carry out the purposes of this Agreement. Unless hereafter specified, neither party shall be responsible for the service of the other. Contractor shall require all subcontractors to comply with the provisions of this agreement.

2.9 Additional Services. City shall have the right at any time during the performance of the services, without invalidating this Agreement, to order extra work beyond that specified in the Scope of Services or make changes by altering, adding to or deducting from said work. No

such extra work may be undertaken unless a written change order is first given by the Contract Officer to the Contractor, incorporating therein any adjustment in (i) the Contract Sum as set forth in Section 3.1, and/or (ii) the time to perform this Agreement, which said adjustments are subject to the written approval of the Contractor. Any increase in compensation of twenty five percent (25%) or less of the Contract Sum, or in the time to perform of one hundred eighty (180) days or less may be approved by the Contract Officer. Any increases, taken either separately or cumulatively, that result in the Contract Sum exceeding \$25,000 must be approved by the City Council. It is expressly understood by Contractor that the provisions of this Section shall not apply to services specifically set forth in the Scope of Services or reasonably contemplated therein. Contractor hereby acknowledges that it accepts the risk that the services to be provided pursuant to the Scope of Services may be more costly or time consuming than Contractor anticipates and that Contractor shall not be entitled to additional compensation therefore.

2.10 Prevailing Wage Laws. Contractor represents and warrants that it is registered with the Department of Industrial Relations pursuant to SB 854 and Labor Code 1725.5. Contractor shall ensure that its subcontractors comply with said requirements. In accordance with Labor Code Section 1770 et seq., the Director of the Department of Industrial Relations of the State of California has ascertained a general prevailing rate of wages, which is the minimum amount, which shall be paid to all workers employed to perform the work pursuant to this Agreement. A copy of the general prevailing wage rate determination is on file in the Office of the City Clerk and is hereby incorporated by reference into this Agreement. In accordance with the provisions of Labor Code Section 1810 et seq., eight (8) hours is the legal working day. Contractor must forfeit to the City Twenty Five Dollars (\$25.00) a day for each worker who works in excess of the minimum working hours when Contractor does not pay overtime. Contractor is required to post a copy of such wage rates at all times at the contract site. The statutory penalties for failure to pay prevailing wage or to comply with State wage and hour laws will be enforced. Contractor also shall comply with State law requirements to maintain payroll records and shall provide for certified records and inspection of records as required by California Labor Code Section 1770 et. seq., including Section 1776. Contractor shall comply with all statutory requirements relating to the employment of apprentices.

3.0 COMPENSATION

3.1 Contract Sum. For the services rendered pursuant to this Agreement, the Contractor shall be compensated as specified herein, but not exceeding the maximum contract amount of Two Hundred Fifty Thousand Dollars (\$250,000) (herein "Contract Sum"), except as provided in Section 2.9. The Contract Sum shall include the attendance of Contractor at all project meetings reasonably deemed necessary by the City; Contractor shall not be entitled to any additional compensation for attending said meetings.

3.2 Progress Payments. Prior to the first day of the month, during the progress of the work, commencing on the day and month specified in the Agreement, Contractor shall submit to the Contract Officer a complete itemized statement of all labor and materials incorporated into the work during the preceding month and the portion of the contract sum applicable thereto. Upon approval in writing by the Contract Officer, payment shall be made in thirty (30) days. City shall pay Contractor a sum based upon ninety-five percent (95%) of the contract price apportionment of the labor and materials incorporated into the work under the contract during the month covered by said statement. The remaining five percent (5%) thereof

shall be retained as performance security. Refer to Section 8.4 of this Agreement for retention of funds.

4.0 PERFORMANCE SCHEDULE

4.1 Time of Essence. Time is of the essence in the performance of this Agreement.

4.2 Schedule of Performance. Contractor shall commence the services pursuant to this Agreement upon receipt of a written notice to proceed and shall perform all services within the time period(s) established in the "Schedule of Performance." Services may be approved in writing by the Contract Officer.

4.3 Force Majeure. The time period(s) specified in the Scope of Services for performance of the services rendered pursuant to this Agreement shall be extended because of any delays due to unforeseeable causes beyond the control and without the fault or negligence of the Contractor, including, but not restricted to, acts of God or of the public enemy, unusually severe weather, fires, earthquakes, floods, epidemics, quarantine restrictions, riots, strikes, freight embargoes, wars, litigation, and/or acts of any governmental agency, including the City, if the Contractor shall within ten (10) days of the commencement of such delay notify the Contract Officer in writing of the causes for the delay. The Contract Officer shall ascertain the facts and the extent of delay, and extend the time for performing the services for the period of the enforced delay when and if in the judgment of the Contract Officer such delay is justified. The Contract Officer's determination shall be final and conclusive upon the parties to this Agreement.

4.4 Term. Unless earlier terminated in accordance with Section 8.9 of this Agreement, this Agreement shall continue in full force and effect until final approval and acceptance of the project by the Contract Officer. Notwithstanding the foregoing, this Agreement shall terminate no later than December 31 , 2022, unless the parties mutually agree in writing to extend the term.

5.0 COORDINATION OF WORK

5.1 Representative of Contractor. The following principals of Contractor are hereby designated as being the principals and representatives of Contractor authorized to act in its behalf with respect to the work specified herein and make all decisions in connection therewith: Glenn Chavez.

It is expressly understood that the experience, knowledge, capability and reputation of the foregoing principals were a substantial inducement for City to enter into this Agreement. Therefore, the foregoing principals shall be responsible during the term of this Agreement for directing all activities of Contractor and devoting sufficient time to personally supervise the services hereunder. For purposes of this Agreement, the foregoing principals may not be replaced nor may their responsibilities be substantially reduced by Contractor without the express written approval of City.

5.2 Contract Officer. The Contract Officer shall be such person as may be designated by the City Administrator or City Engineer of City. It shall be the Contractor's

responsibility to assure that the Contract Officer is kept informed of the progress of the performance of the services and the Contractor shall refer any decisions that must be made by City to the Contract Officer. Unless otherwise specified herein, any approval of City required hereunder shall mean the approval of the Contract Officer. The Contract Officer shall have authority to sign all documents on behalf of the City required hereunder to carry out the terms of this Agreement.

5.3 Prohibition Against Assignment. The experience, knowledge, capability and reputation of Contractor, its principals and employees were a substantial inducement for the City to enter into this Agreement. Neither this Agreement nor any interest herein may be transferred, assigned, conveyed, hypothecated or encumbered voluntarily or by operation of law, whether for the benefit of creditors or otherwise, without the prior written approval of City. Transfers restricted hereunder shall include the transfer to any person or group of persons acting in concert of more than twenty five percent (25%) of the present ownership and/or control of Contractor, taking all transfers into account on a cumulative basis. In the event of any such unapproved transfer, including any bankruptcy proceeding, this Agreement shall be void. No approved transfer shall release the Contractor or any surety of Contractor of any liability hereunder without the express consent of City.

5.4 Independent Contractor. Neither the City nor any of its employees shall have any control over the manner, mode or means by which Contractor, its subcontractors, agents or employees, performs the services required herein, except as otherwise set forth herein. City shall have no voice in the selection, discharge, supervision or control of Contractor's employees, subcontractors, servants, representatives or agents, or in fixing their number, compensation or hours of service. Contractor shall perform all services required herein as an independent contractor of City and shall remain at all times as to City a wholly independent contractor with only such obligations as are consistent with that role. Contractor shall not at any time or in any manner represent that it or any of its subcontractors, agents or employees are agents or employees of City. City shall not in any way or for any purpose become or be deemed to be a partner of Contractor in its business or otherwise or a joint venture or a member of any joint enterprise with Contractor.

5.5 Identity of Persons Performing Work. Contractor represents that it employs or will employ at its own expense all personnel required for the satisfactory performance of any and all tasks and services set forth herein. Contractor represents that the tasks and services required herein will be performed by Contractor or under its direct supervision, and that all personnel engaged in such work shall be fully qualified and shall be authorized and permitted under applicable State and local law to perform such tasks and services.

5.6 Utility Relocation. City is responsible for removal, relocation, or protection of existing main or trunkline utilities to the extent such utilities were not identified in the invitation for bids or specifications. City shall reimburse contractor for any costs incurred in locating, repairing damage not caused by contractor and removing or relocating such unidentified utility facilities, including equipment idled during such work. Contractor shall not be assessed liquidated damages for delay arising from the removal or relocation of such unidentified utility facilities.

5.7 Trenches or Excavations. Pursuant to California Public Contract Code Section 7104, in the event the work included in this Agreement requires excavations more than four (4) feet in depth, the following shall apply.

- (a) Contractor shall promptly, and before the following conditions are disturbed, notify City, in writing, of any: (1) material that Contractor believes may be material that is hazardous waste, as defined in Section 25117 of the Health and Safety Code, that is required to be removed to a Class I, Class II, or Class III disposal site in accordance with provisions of existing law; (2) Subsurface or latent physical conditions at the site different from those indicated; or (3) Unknown physical conditions at the site of any unusual nature, different materially from those ordinarily encountered and generally recognized as inherent in work of the character provided for in the contract.
- (b) City shall promptly investigate the conditions, and if it finds that the conditions do materially so differ, or do involve hazardous waste, and cause a decrease or increase in Contractor's cost of, or the time required for, performance of any part of the work shall issue a change order per Section 2.9 of this Agreement.
- (c) That, in the event that a dispute arises between City and Contractor whether the conditions materially differ, or involve hazardous waste, or cause a decrease or increase in Contractor's cost of, or time required for, performance of any part of the work, Contractor shall not be excused from any scheduled completion date provided for by the contract, but shall proceed with all work to be performed under the contract. Contractor shall retain any and all rights provided either by contract or by law, which pertain to the resolution of disputes and protests between the contracting parties.

6.0 INSURANCE, INDEMNIFICATION AND BONDS

6.1 Insurance. The Contractor and all subcontractors, if any, shall procure and maintain, at its sole cost and expense, in a form and content satisfactory to City, during the entire term of this Agreement including any extension thereof, insurance as set forth in Exhibit "B" attached hereto and incorporated herein by this reference.

Conditions:

In accordance with Public Contract Code Section 20170, the insurance of surety companies who provide or issue the policy shall have been admitted to do business in the State of California with a credit rating of A- or better.

This insurance shall not be canceled, limited in scope or coverage or non-renewed until after thirty (30) days prior written notice has been given to the Public Works Director, City of La Habra, 110 E. La Habra Blvd., La Habra, California 90631.

Any insurance maintained by the City of La Habra shall apply in excess of and not combined with insurance provided by this policy.

The City of La Habra, its officers, employees, representatives, attorneys, and volunteers shall be named as additional named insureds.

Prior to commencement of any work under this contract, Contractor shall deliver to the City insurance endorsements confirming the existence of the insurance required by this contract, and including the applicable clauses referenced above.

Such endorsements shall be signed by an authorized representative of the insurance company and shall include the signator's company affiliation and title. Should it be deemed necessary by the City, it shall be Contractor's responsibility to see that the City receives documentation, acceptable to the City, which sustains that the individual signing said endorsements is indeed authorized to do so by the insurance company.

If the Contractor fails to maintain the aforementioned insurance, or secure and maintain the aforementioned endorsement, the City may obtain such insurance, and deduct and retain the amount of the premiums for such insurance from any sums due under the agreement. However, procuring of said insurance by the City is an alternative to other remedies the City may have, and is not the exclusive remedy for failure of Contractor to maintain said insurance or secure said endorsement. In addition to any other remedies the City may have upon Contractor's failure to provide and maintain any insurance or policy endorsements to the extent and within the time herein required, the City shall have the right to order Contractor to stop work hereunder, and/or withhold any payment(s) which became due to Contractor hereunder until Contractor demonstrates compliance with the requirements hereof.

Nothing herein contained shall be construed as limiting in any way the extent to which Contractor may be held responsible for payments of damages to persons or property resulting from Contractor's or its subcontractor's performance of the work covered under this agreement.

Each contract between the Contractor and any subcontractor shall require the subcontractor to maintain the same policies of insurance that the Contractor is required to maintain pursuant to this Section 6.1.

6.2 Certificates of Insurance. Contractor shall provide to City certificates of insurance showing the insurance coverages and required endorsements described above, in a form and content approved by City, prior to performing any services under this Agreement. The certificates of insurance and endorsements shall be attached to this Agreement as Exhibit "C", and are incorporated herein by this reference.

6.3 Indemnification. Contractor shall defend, indemnify, hold free and harmless the City of La Habra, its elected and appointed officials, officers, agents and employees, at Contractor's sole expense, from and against any and all actions, suits, claims, damages to persons or property, losses, costs, penalties, obligations, errors, omissions or liabilities, (herein "claims or liabilities") that may be asserted or claimed by any person, firm or entity arising or alleged to arise out of or in connection with the performance of the work, operations or activities of Contractor, its agents, employees, subcontractors, or invitees, provided for herein, or arising or alleged to arise from the negligent acts or omissions of Contractor hereunder, or arising or alleged to arise from Contractor's performance of or failure to perform any term, provision, covenant or condition of this Agreement.

- (a) Contractor will defend any action or actions filed in connection with any of said claims or liabilities and will pay all costs and expenses, including legal costs and attorneys' fees incurred in connection therewith.
- (b) Contractor will promptly pay any judgment rendered against the City, its officers, agents or employees for any such claims or liabilities arising or alleged to arise out of or in connection with Contractor's (or its agents', employees', subcontractors' or invitees') negligent performance of or failure to perform such work, operations or activities hereunder; and Contractor agrees to save and hold the City, its officers, agents, and employees harmless therefrom.
- (c) In the event the City, its officers, agents or employees is made a party to any action or proceeding filed or prosecuted against Contractor for such damages or other claims arising or alleged to arise out of or in connection with the performance of or failure to perform the work, operation or activities of Contractor hereunder, Contractor shall pay to the City, its officers, agents or employees, any and all costs and expenses incurred by the City, its officers, agents or employees in such action or proceeding, including but not limited to, legal costs and attorneys' fees for counsel selected by City.
- (d) Contractor's duty to defend and indemnify as set out in this Section 6.3 shall include any claims, liabilities, obligations, losses, demands, actions, penalties, suits, costs, expenses or damages or injury to persons or property arising or alleged to arise from, in connection with, as a consequence of or pursuant to any state or federal law or regulation regarding hazardous substances, including but not limited to the Federal Insecticide, Fungicide and Rodenticide Act ("FIFRA"), Comprehensive Environmental Response, Compensation and Liability Act of 1980 ("CERCLA"), Resource Conservation and Recovery Act of 1976 ("RCRA"), the Hazardous and Solid Waste Amendments of 1984, the Hazardous Material Transportation Act, the Toxic Substances control Act, the Clean Air Act, the Clean Water Act, the California Hazardous Substance Account Act, the California Hazardous Waste Control Law or the Porter-Cologne Water Quality Control Act, as any of those statutes may be amended from time to time.

Notwithstanding the foregoing, Contractor shall not be liable for the defense or indemnification of the City for claims, actions, complaints or suits arising out of the sole active negligence or willful misconduct of the City.

The Contractor's indemnification obligations pursuant to this Section 6.3 shall survive the termination of this Agreement. Contractor shall require the same indemnification from all subcontractors.

6.4 Labor and Materials and Performance Bonds. Concurrently with execution of this Agreement, Contractor shall deliver to City a labor and materials bond and a performance bond each in the sum of the amount of this Agreement, in the forms provided by the City Clerk, which secures the faithful performance of this Agreement. The bonds shall contain the original

notarized signature of an authorized officer of the surety and affixed thereto shall be a certified and current copy of his power of attorney. The bonds shall be unconditional and remain in force during the entire term of the Agreement and shall be null and void only if the Contractor promptly and faithfully performs all terms and conditions of this Agreement.

6.5 Sufficiency of Insurer or Surety. Insurance required by this Agreement shall be satisfactory only if issued by companies qualified to do business in California, rated "A" or better in the most recent edition of Best Rating Guide, The Key Rating Guide or in the Federal Register, and only if they are of a financial category Class VII or better, unless such requirements are waived by the Risk Manager of the City due to unique circumstances. In the event the Senior Management Analyst of City ("Senior Management Analyst") determines that the work or services to be performed under this Agreement creates an increased risk of loss to the City, the Contractor agrees that the minimum limits of the insurance policies required by this Section 6 may be changed accordingly upon receipt of written notice from the Senior Management Analyst; provided that the Contractor shall have the right to appeal a determination of increased coverage by the Senior Management Analyst to the City Council of City within ten (10) days of receipt of notice from the Senior Management Analyst.

6.6 Substitution of Securities. Pursuant to California Public Contract Code Section 22300, substitution of eligible equivalent securities for any monies withheld to ensure performance under the contract for the work to be performed will be permitted at the request and expense of the successful bidder.

7.0 RECORDS AND REPORTS

7.1 Reports. Contractor shall periodically prepare and submit to the Contract Officer such reports concerning the performance of the services required by this Agreement as the Contract Officer shall require. Contractor hereby acknowledges that the City is greatly concerned about the cost of work and services to be performed pursuant to this Agreement. For this reason, Contractor agrees that if Contractor becomes aware of any facts, circumstances, techniques, or events that may or will materially increase or decrease the cost of the work or services contemplated herein or, if Contractor is providing design services, the cost of the project being designed, Contractor shall promptly notify the Contract Officer of said fact, circumstance, technique or event and the estimated increased or decreased cost related thereto and, if Contractor is providing design services, the estimated increased or decreased cost estimate for the project being designed.

7.2 Records. Contractor shall keep, and require subcontractors to keep, such books and records (including but not limited to payroll records as required herein) as shall be necessary to perform the services required by this Agreement and enable the Contract Officer to evaluate the performance of such services. The Contract Officer shall have full and free access to such books and records at all times during normal business hours of City, including the right to inspect, copy, audit and make records and transcripts from such records. Such records shall be maintained for a period of three (3) years following completion of the services hereunder, and the City shall have access to such records in the event any audit is required.

7.3 Ownership of Documents. All drawings, specifications, reports, records, documents and other materials prepared by Contractor, its employees, subcontractors and agents in the performance of this Agreement shall be the property of City and shall be delivered to City

upon request of the Contract Officer or upon the termination of this Agreement, and Contractor shall have no claim for further employment or additional compensation as a result of the exercise by City of its full rights of ownership of the documents and materials hereunder. Contractor may retain copies of such documents for its own use. Contractor shall have an unrestricted right to use the concepts embodied therein. All subcontractors shall provide for assignment to City of any documents or materials prepared by them, and in the event Contractor fails to secure such assignment, Contractor shall indemnify City for all damages resulting therefrom.

7.4 Public Records Act Disclosure. Contractor has been advised and is aware that this Agreement and all reports, documents, information and data, including, but not limited to, computer tapes, discs or files furnished or prepared by Contractor, or any of its subcontractors, pursuant to this Agreement and provided to City may be subject to public disclosure as required by the California Public Records Act (California Government Code Section 6250 *et seq.*). Exceptions to public disclosure may be those documents or information that qualify as trade secrets, as that term is defined in the California Government Code Section 6254.7, and of which Contractor informs City of such trade secret. The City will endeavor to maintain as confidential all information obtained by it that is designated as a trade secret. The City shall not, in any way, be liable or responsible for the disclosure of any trade secret including, without limitation, those records so marked if disclosure is deemed to be required by law or by order of the Court.

8.0 GENERAL PROVISIONS

8.1 Governing Law. This Agreement shall be construed and interpreted both as to validity and to performance of the parties in accordance with the laws of the State of California. Legal actions concerning any dispute, claim or matter arising out of or in relation to this Agreement shall be instituted in the Superior Court of the County of Orange, State of California, or any other appropriate court in such county, and Contractor covenants and agrees to submit to the personal jurisdiction of such court in the event of such action.

8.2 Representatives. The City Administrator or his or her designee shall be the representative of City for purposes of this Agreement and may issue all consents, approvals, directives and agreements on behalf of the City, called for by this Agreement, except as otherwise expressly provided in this Agreement.

The Principal set forth in Section 5.1 above shall be the representative for Contractor for purposes of this Agreement, and shall be authorized to issue all consents, approvals, directives and agreements on behalf of Contractor called for by this Agreement, except as otherwise expressly provided in this Agreement.

8.3 Disputes. In the event either party fails to perform its obligations hereunder, the nondefaulting party shall provide the defaulting party written notice of such default. The defaulting party shall have ten (10) days to cure the default; provided that, if the default is not reasonably susceptible to being cured within said ten (10) day period, the defaulting party shall have a reasonable time to cure the default, not to exceed a maximum of thirty (30) days, so long as the defaulting party commences to cure such default within ten (10) days of service of such notice and diligently prosecutes the cure to completion; provided further that if the default is an immediate danger to the health, safety and general welfare, the defaulting party shall take such immediate action as may be necessary. Notwithstanding the foregoing, the nondefaulting party

may, in its sole and absolute discretion, grant a longer cure period. Should the defaulting party fail to cure the default within the time period provided in this Section, the nondefaulting party shall have the right, in addition to any other rights the nondefaulting party may have at law or in equity, to terminate this Agreement. Compliance with the provisions of this Section 8.3 shall be a condition precedent to bringing any legal action, and such compliance shall not be a waiver of any party's right to take legal action in the event that the dispute is not cured.

8.4 Retention of Funds. Progress payments shall be made in accordance with the provisions of Section 3.2 of this Agreement. In accordance with said section, City shall pay Contractor a sum based upon ninety-five percent (95%) of the contract price apportionment of the labor and materials incorporated into the work under the contract during the month covered by said statement. The remaining five percent (5%) thereof shall be retained as performance security to be paid to the Contractor within sixty (60) days after final acceptance of the work by the City Council, after Contractor shall have furnished City with a release of all undisputed contract amounts if required by City. In the event there are any claims specifically excluded by Contractor from the operation of the release, the City may retain proceeds (per Public Contract Code 7107) of up to 150% of the amount in dispute. City's failure to deduct or withhold shall not affect Contractor's obligations hereunder.

8.5 Waiver. No delay or omission in the exercise of any right or remedy by a nondefaulting party on any default shall impair such right or remedy or be construed as a waiver. A party's consent to or approval of any act by the other party requiring the party's consent or approval shall not be deemed to waive or render unnecessary the other party's consent to or approval of any subsequent act. Any waiver by either party of any default must be in writing and shall not be a waiver of any other default concerning the same or any other provision of this Agreement.

8.6 Rights and Remedies. Rights and Remedies are cumulative except with respect to rights and remedies expressly declared to be exclusive in this Agreement, the rights and remedies of the parties are cumulative and the exercise by either party of one or more of such rights or remedies shall not preclude the exercise by it, at the same or different times, of any other rights or remedies for the same default or any other default by the other party.

8.7 Legal Action. In addition to any other rights or remedies, either party may take legal action, in law or in equity, to cure, correct or remedy any default, to recover damages for any default, to compel specific performance of this Agreement, to obtain declaratory or injunctive relief, or to obtain any other remedy consistent with the purposes of this Agreement.

8.8 Liquidated Damages. Since the determination of actual damages for any delay in performance of this Agreement would be extremely difficult or impractical to determine in the event of a breach of this Agreement, the Contractor and its sureties shall be liable for and shall pay to the City Five Hundred Dollars (\$500) as liquidated damages for each working day of delay in the performance of any service required hereunder, as specified in the Scope of Services (Exhibit A). The City may withhold from any monies payable on account of services performed by the Contractor any accrued liquidated damages.

8.9 Termination for Default of Contractor. If termination is due to the failure of the Contractor to fulfill its obligations under this Agreement, Contractor shall vacate any City owned property which Contractor is permitted to occupy hereunder and City may, after compliance with the provisions of Section 8.3, take over the work and prosecute the same to

completion by contract or otherwise, and the Contractor shall be liable to the extent that the total cost for completion of the services required hereunder exceeds the compensation herein stipulated (provided that the City shall use reasonable efforts to mitigate such damages), and City may withhold any payments to the Contractor for the purpose of setoff or partial payment of the amounts owed the City as previously stated.

8.10 Notice. Any notice, demand, request, document, consent, approval, or communication either party desires or is required to give to the other party or any other person shall be in writing and shall be deemed to be given when served personally or deposited in the US Mail, prepaid, first-class mail, return receipt requested, addressed as follows:

To City: City of La Habra
110 E. La Habra Blvd
La Habra, California 90631
Attn.: Albert Mendoza

To Contractor: Glenn Chavez Construction
460 W Lambert Rd. #K
Brea, Ca. 92821

8.11 Non-liability of City Officers and Employees. No officer or employee of the City shall be personally liable to the Contractor, or any successor in interest, in the event of any default or breach by the City or for any amount which may become due to the Contractor or to its successor, or for breach of any obligation of the terms of this Agreement.

8.12 Conflict of Interest. The Contractor warrants that it has not paid or given and will not pay or give any third party any money or other consideration for obtaining this Agreement.

Contractor and its officers, employees, associates and subcontractors, if any, will comply with all conflict of interest statutes of the State of California applicable to Contractor's services under this agreement, including, but not limited to, the Political Reform Act (Government Code Sections 81000, *et seq.*) and Government Code Section 1090. During the term of this Agreement, Contractor and its officers, employees, associates and subcontractor shall not, without the prior written approval of the City Representative, perform work for another person or entity for whom Contractor is not currently performing work that would require Contractor or one of its officers, employees, associates or subcontractors to abstain from a decision under this Agreement pursuant to a conflict of interest statute.

8.13 Covenant Against Discrimination. Contractor covenants that, by and for itself, its heirs, executors, assigns, and all persons claiming under or through them, that there shall be no discrimination against or segregation of, any person or group of persons on account of race, color, creed, religion, sex, marital status, national origin, or ancestry in the performance of this Agreement. To the extent required by law, contractor shall take affirmative action to insure that applicants are employed and that employees are treated during employment without regard to their race, color, creed, religion, sex, marital status, national origin, or ancestry.

8.14 Interpretation. The terms of this Agreement shall be construed in accordance with the meaning of the language used and shall not be construed for or against either party by reason of the authorship of this Agreement or any other rule of construction which might otherwise apply.

8.15 Severability. In the event that any one or more of the phrases, sentences, clauses, paragraphs, or sections contained in this Agreement shall be declared invalid or unenforceable by a valid judgment or decree of a court of competent jurisdiction, such invalidity or unenforceability shall not affect any of the remaining phrases, sentences, clauses, paragraphs, or sections of this Agreement which are hereby declared as severable and shall be interpreted to carry out the intent of the parties hereunder unless the invalid provision is so material that its invalidity deprives either party of the basic benefit of their bargain or renders this Agreement meaningless.

8.16 [reserved]

8.17 Unfair Business Practices Claims. In entering into a public works contract or a subcontract to supply goods, services or materials pursuant to a public works contract, the contractor or subcontractor offers and agrees to assign to the awarding body all rights, title, and interest in and to all causes of action it may have under Section 4 of the Clayton Act (15 U.S.C. Sec. 15) or under the Cartwright Act (Chapter 2, (commencing with Section 16700) of Part 2 of Division 7 of the Business and Professions Code), arising from purchases of goods, services or materials pursuant to the public works contract or the subcontract. This assignment shall be made and become effective at the time the awarding body renders final payment to the contractor without further acknowledgment by the parties. (Sec. 7103.5, California Public Contract Code).

8.18 Corporate Authority. The persons executing this Agreement on behalf of the parties hereto warrant that (i) such party is duly organized and existing, (ii) they are duly authorized to execute and deliver this Agreement on behalf of said party, (iii) by so executing this Agreement, such party is formally bound to the provisions of this Agreement, and (iv) the entering into this Agreement does not violate any provision of any other Agreement to which said party is bound.

8.19 PERS Eligibility Indemnification. In the event that Contractor or any employee, agent, or subcontractor of Contractor providing services under this Agreement claims or is determined by a court of competent jurisdiction or the California Public Employees Retirement System (PERS) to be eligible for enrollment in PERS as an employee of the City, Contractor shall indemnify, defend, and hold harmless City for the payment of any employee and/or employer contributions for PERS benefits on behalf of Contractor or its employees, agents, or subcontractors, as well as for the payment of any penalties and interest on such contributions, which would otherwise be the responsibility of City.

Notwithstanding any other agency, state or federal policy, rule, regulation, law or ordinance to the contrary, Contractor and any of its employees, agents, and subcontractors providing service under this Agreement shall not qualify for or become entitled to, and hereby agree to waive any claims to, any compensation, benefit, or any incident of employment by City, including but not limited to eligibility to enroll in PERS as an employee of City and entitlement to

any contribution to be paid by City for employer contribution and/or employee contributions for PERS benefits.

8.20 Cooperation. In the event any claim or action is brought against City relating to Contractor's performance or services rendered under this Agreement, Contractor shall render any reasonable assistance and cooperation which City might require.

8.21 Legal Responsibilities. The Contractor shall keep itself informed of City, State, and Federal laws, ordinances and regulations, which may in any manner affect the performance of its services pursuant to this Agreement. The Contractor shall at all times observe and comply with all such laws, ordinances and regulations. Neither the City, nor its officers, agents, or employees shall be liable at law or in equity as a result of the Contractor's failure to comply with this section.

8.22 Termination for Convenience. The City may terminate this Agreement without cause for convenience of the City upon giving contractor 30 days prior written notice of termination of the Agreement. Upon receipt of the notice of termination the Contractor shall cease all further work pursuant to the Agreement. Upon such termination by the City the Contractor shall not be entitled to any other remedies, claims, actions, profits, or damages except as provided in this paragraph. Upon the receipt of such notice of termination Contractor shall be entitled to the following compensation:

1. The contract value of the work completed to and including the date of receipt of the notice of termination, less the amount of progress payments received by contractor.
2. Actual move-off costs including labor, rental fees, equipment transportation costs, the costs of maintaining on-site construction office for supervising the mover-off.
3. The cost of materials custom made for this Agreement which cannot be used by the Contractor in the normal course of his business, and which have not been paid for by City in progress payments.
4. All costs shall not include any markups as might otherwise be allowed by any plans or specifications which were a part of the Agreement.

The provisions of this paragraph shall supersede any other provision of the Agreement or any provision of any plans, specification, addendums or other documents which are or may become a part of this Agreement. City and Contractor agree that the provisions of this paragraph are a substantive part of the consideration for this Agreement.

8.23 Responsibility for Errors. Contractor shall be responsible for its work and results under this Agreement. Contractor, when requested, shall furnish clarification and/or explanation as may be required by the City's representative, regarding any services rendered under this Agreement at no additional cost to City. In the event that an error or omission attributable to Contractor occurs, then Contractor shall, at no cost to City, provide all necessary design drawings, estimates and other Contractor professional services necessary to rectify and correct the matter to the sole satisfaction of City and to participate in any meeting required with regard to the correction.

8.24 Order of Precedence. In the event of an inconsistency in this Agreement and any of the attached Exhibits, the terms set forth in this Agreement shall prevail. If, and to the extent this Agreement incorporates by reference any provision of any document, such provision shall be deemed a part of this Agreement. Nevertheless, if there is any conflict among the terms and conditions of this Agreement and those of any such provision or provisions so incorporated by reference, this Agreement shall govern over the document referenced.

8.25 Costs. Each party shall bear its own costs and fees incurred in the preparation and negotiation of this Agreement and in the performance of its obligations hereunder except as expressly provided herein.

8.26 No Third Party Beneficiary Rights. This Agreement is entered into for the sole benefit of City and Contractor and no other parties are intended to be direct or incidental beneficiaries of this Agreement and no third party shall have any right in, under or to this Agreement.

8.27 Headings. Paragraphs and subparagraph headings contained in this Agreement are included solely for convenience and are not intended to modify, explain or to be a full or accurate description of the content thereof and shall not in any way affect the meaning or interpretation of this Agreement.

8.28 Construction. The parties have participated jointly in the negotiation and drafting of this Agreement. In the event an ambiguity or question of intent or interpretation arises with respect to this Agreement, this Agreement shall be construed as if drafted jointly by the parties and in accordance with its fair meaning. There shall be no presumption or burden of proof favoring or disfavoring any party by virtue of the authorship of any of the provisions of this Agreement.

8.29 Counterparts. This Agreement may be executed in one or more counterparts, each of which shall be deemed an original. All counterparts shall be construed together and shall constitute one agreement.

8.30 Funding Source Conditions – Contractor's Obligation. Contractor acknowledges that the City may be paying for the Project by using funds it receives or will receive from various funding sources in the form of grants and/or subsidies, and the like under certain terms and conditions. Contractor acknowledges and agrees that any failure of the Contractor and/or its subcontractors to perform its obligations under the Contract, including, but not limited to, timely submitting accurate reports and records, that in any way results in the City not meeting the terms and conditions placed on the funds by the funding source, or forfeiting its entitlement to or, otherwise, not receiving, the funds, then the Contractor shall be liable to pay the City for the funds not granted to the City on the Project.

8.31 Entire Agreement. This Agreement constitutes the entire agreement between the parties with respect to any matter referenced herein and supersedes any and all other prior writings and oral negotiations. This Agreement may be modified only in writing, and signed by the parties in interest at the time of such modification. The terms of this Agreement shall prevail over any inconsistent provision in any other contract document appurtenant hereto, including exhibits to this Agreement.

IN WITNESS WHEREOF, the parties have executed and entered into this Agreement as of the date first written above.

CITY OF LA HABRA,
A municipal corporation

Jim Sadro, City Manager

Date: _____

CONTRACTOR

Signature

Date: _____

Name and Title

Social Security or Taxpayer ID Number

ATTEST:

_____, City Clerk

APPROVED AS TO FORM:

Richard D. Jones, City Attorney

Date: _____

**LABOR AND MATERIAL PAYMENT BOND
PUBLIC WORK (CALIFORNIA)**

KNOW ALL MEN BY THESE PRESENT:

WHEREAS, Glenn Chavez Construction, as Principal, has entered into a contract dated November 21, 2022, with the City of La Habra (Obligee) referred to and made a part hereof to perform the following work, to wit: Heli-Hydrant Project, City Project No. 1-W-23 and all appurtenant work in accordance with PROJECT NO. 1-W-23, which requires Principal to file this bond to secure claims made in relation to the project.

NOW THEREFORE, we, _____, as Principal, and _____, a corporation organized under the laws of _____ and duly authorized to transact business in the State of California, as Surety, are held firmly bound unto the City of La Habra, as Obligee, and all sub-contractors, laborers, material persons and other persons employed in the performance of the referenced agreement, in the sum of Two Hundred Fifty Thousand Dollars (\$250,000.00), lawful money of the United States of America, for the payment whereof well and truly to be made the Principal and Surety bind themselves, their heirs, executors, administrators, successors, and assigns, jointly and severally, firmly by these presents.

If the above bounden PRINCIPAL, his or its heirs, executors, administrators, successors, assigns, or any of his or its sub-contractors, fails to pay for any materials, provisions, provender, or other supplies, or teams, implements or machinery, used in, upon, for or about the performance of the work contracted to be done, or for any work or labor to persons named in Section 9100 or the Civil Code, thereon of any kind, or for amounts due under the Unemployment Insurance Code with respect to such work or labor deducted, withheld and paid over to the Employment Development Department from the wages of employees of the contractor and sub-contractors pursuant to Section 13020 of the Unemployment Insurance Code, that the SURETY on this bond will pay the same, in an amount not exceeding the sum specified in this bond, AND ALSO, in case suit is brought upon this bond, a reasonable attorney's fee, which shall be awarded by the court to the prevailing party in said suit, said attorney's fee to be taxed as costs in said suit and to be included in the judgment herein rendered.

As part of the obligation secured hereby, the SURETY shall not be exonerated or released from the obligation of the bond by any change, alteration, or modification in or of any contract, plans, specifications, or agreement pertaining or relating to any scheme or work of improvement or pertaining or relating to the furnishing of labor, materials, or equipment therefor, nor by any change or modification of any terms of payment or extension of the time for any payment pertaining or relating to any scheme of work of improvement, nor by any rescission or attempted rescission of the contract, agreement or bond, nor by any conditions precedent or subsequent in the bond attempting to limit the right of recovery of claimants otherwise entitled to recover under

any such contract or agreement, or under the bond, nor, where the bond is given for the benefit of claimants, by any fraud practiced by any person other than the claimant seeking to recover on the bond.

This bond shall inure to the benefit of any and all persons, companies and corporations entitled to file claims under the Civil Code so as to give them a right of action in a suit on this bond.

This bond is executed for the purpose of complying with the laws of the State of California and shall inure to the benefit of any of the persons named in Section 9100 of the Civil Code of the State of California.

IN WITNESS THEREOF, we have hereunto set our hands and seals this _____ day of _____, 20__.

(Corporate Seal)

Principal

By _____

Title

(Corporate Seal)

Principal

By _____

Title

APPROVED AS TO FORM:

/s/ Richard D. Jones

City Attorney

FAITHFUL PERFORMANCE BOND

KNOW ALL MEN BY THESE PRESENTS:

That we, _____

_____ hereinafter referred to as

“Contractor”, as principal, and _____

_____ as surety, are held and firmly

bound unto City of La Habra in the sum of _____

_____ Lawful money of the United States of America for the payment of which sum well and truly to be made we bind ourselves jointly and severally, firmly by these presents.

The condition of the foregoing obligation is such that WHEREAS, said Contract has been awarded and is about to enter into the annexed contract with City of La Habra for construction of Street Improvements as specifically set forth in the documents entitled:

**HELI-HYDRANT PROJECT
CITY PROJECT NO. 1-W-23**

and is required under the terms of the Contract to give this bond in connection with the execution of said contract.

NOW, THEREFORE, if the said Contractor shall well and truly do and perform all of the covenants and obligations of said contract on his part to be done and performed at the times and in the manner specified herein, then this obligation shall be null and void, otherwise it shall be and remain in full force and effect.

PROVIDED, that any alterations in the work to be done or the materials to be furnished which may be made pursuant to the terms of said Contract shall not in any way release either the Contractor or the surety thereunder nor shall any extensions of time granted under the provisions of said Contract release either the Contractor or the surety, and notice of such alterations or extensions of the Contract is hereby waived by the surety.

WITNESS our hands this _____ day of _____, 2022.

Contractor

BY: _____

(Seal)

Title

APPROVED:

Surety

BY: _____

(Seal)

Mailing Address of Surety:

Telephone Number of Surety

SUPPLEMENTAL INFORMATION TO BE COMPLETED BY PRINCIPAL

If an individual, so state. If a firm or co-partnership, state the firm and give the names of all individual co-partners composing the partnership. If a Corporation, state legal name of corporation; state also the names of the president, secretary, treasurer and manager thereof.

Business Address:

Telephone Number: _____

Date: _____

Print Name: _____
Principal

Signature: _____
Title

TAX IDENTIFICATION NUMBER

The Tax Equity and Fiscal Responsibility Act of 1982 requires the payer (City of La Habra) to report to the Internal Revenue Service taxable payments to payees.

You (as a payee) are required by law to provide us with your Taxpayer Identification Number (if an individual or partnership, your Social Security Number). If you do not provide us with your correct identification number, you may be subject to a penalty imposed by the Internal Revenue Service. The payments subject to withholdings may include, but are not limited to, interest, dividends, or other payments the City of La Habra made to you. Other payments may include rents, royalties, commissions and fees for service of non-employees.

If you are exempt from income tax, we are still required, by law, to maintain a Tax Identification Number on file. **PLEASE PROVIDE YOUR TAX IDENTIFICATION NUMBER next to the appropriate listing below, sign, date and return to:**

CITY OF LA HABRA FINANCE DEPARTMENT
110 E. La Habra Blvd
La Habra, CA 90631

Exempt: Yes___No___ Telephone () _____

CORPORATION: _____

U.S.A. OR ANY AGENCIES THEREOF: _____

IRS CODE #501 TAX-EXEMPT ORGANIZATION: _____

A NON-COMMISSIONED CITY OF LA HABRA EMPLOYEE: _____

SOLE PROPRIETOR: _____

A PARTNERSHIP: _____

OTHER: _____(Explain)

Signature/Title: _____ Date: _____

BID GUARANTEE

**TO THE CITY OF LA HABRA
PROJECT NO. 1-W-23**

As a material inducement to the City to award the contract for Project No. 1-W-23 to _____, the undersigned (“Guarantor”) has agreed to enter into this guarantee. The Guarantor hereby unconditionally guarantees to the fullest extent allowed by law the following work included in this project: Heli-Hydrant Project (“the work”).

Guarantor guarantees that the materials and equipment used by itself and its subcontractors will be free from defects and that the work will conform to the plans and specifications. Should any of the materials or equipment prove defective or should the work as a whole, or any part thereof, prove defective for any reason whatsoever (except due to intentional torts by the City), or should the work as a whole or any part thereof fail to operate properly or fail to comply with the plans and specifications, Guarantor will, at the City’s sole election: 1) reimburse the City, upon written demand, for all of the City’s expenses incurred replacing or restoring any such equipment or materials, including the cost of any work necessary to make such replacement or repairs; or 2) replace any such defective material or equipment and repair said work completely, all without any cost to the City. Guarantor further guarantees that any such repair work will conform to the plans and specifications for the project. This guarantee will remain in effect for five years from the date on which the contracted for work is accepted for use by the City.

Guarantor understands and agrees that the City shall have the unqualified option to make any replacements or repairs itself or to have such replacement, repair, performed by the undersigned. The City shall have no obligation to consult with Guarantor before the City proceeds to perform any repair, replacement, or work itself. If the City elects to have Guarantor perform said repair, replacement, or work, Guarantor agrees that the repair, replacement, or work shall be performed within 15 days after receipt of a written demand from the City.

If the City elects to perform the replacement, repairs itself, Guarantor agrees to make reimbursement payment within 15 days after receipt of a written demand for payment from the City.

If the Guarantor fails or refuses to comply with this guarantee, the City shall be entitled to all costs and expenses, including attorneys and expert fees, reasonably incurred by reason of Guarantor’s failure or refusal.

Guarantor _____ Date: _____

Contractor: _____ By: _____

Title: _____

STATEMENT OF NON COLLUSION BY CONTRACTOR

The undersigned who submits herewith to the City of La Habra a bid or proposal does hereby certify:

- a. That all statements of fact in such bid or proposal are true;
- b. That such bid or proposal was not made in the interest of or on behalf of any undisclosed person, partnership, company, association, organization or corporation;
- c. That such bid or proposal is genuine and not collusive or sham;
- d. That said bidder has not, directly or indirectly by agreement, communication or conference with anyone, attempted to induce action prejudicial to the interest of the City of La Habra or of any other bidder or anyone else interested in the proposed procurement;
- e. Did not, directly or indirectly, collude, conspire, connive or agree with anyone else that said bidder or anyone else would submit a false or sham bid or proposal, or that anyone should refrain from bidding or withdraw his bid or proposal;
- f. Did not in any manner, directly or indirectly seek by agreement, communication or conference with anyone to raise or fix the bid or proposal price of said bidder or of anyone else, or to raise or fix any overhead, profit or cost element of his bid or proposal price, or that of anyone else;
- g. Did not, directly or indirectly, submit his bid or proposal price or any breakdown thereof, or the contents thereof, or divulge information or data relative thereto, to any corporation, partnership, company, association, organization, bid depository, or to any member agent thereof, or to any individual or group of individuals, except to the City of La Habra, or to any person or persons who have a partnership or their financial interest with said bidder in his business.
- h. Did not provide, directly or indirectly to any officer or employee of the City of La Habra any gratuity, entertainment, meals, or anything of value, whatsoever, which could be objectively construed as intending to invoke any form of reciprocation or favorable treatment.
- i. That no officer or principal of the undersigned firm is related to any officer or employee of the city by blood or marriage within the third degree or is employed, either full or part time, by the City of La Habra either currently or within the last two (2) years.
- j. That no officer or principal of the undersigned firm nor any subcontractor to be engaged by the principal has been convicted by a court of competent jurisdiction of any charge of fraud, bribery, collusion, conspiracy or any other act in violation of any state or federal antitrust law in connection with the bidding upon award of, or performance of, any public work contract, with any public entity, within the last three years.

I certify, under penalty of perjury under the laws of the State of California, that the foregoing is true and correct and that this certification was executed:

On _____ at _____ California.

Firm _____

(Signature)

Street _____

(Print Name & Title)

City _____ State _____ Zip _____

CERTIFICATION OF COMPLIANCE

AFFIRMATIVE ACTION REQUIREMENTS

EQUAL EMPLOYMENT OPPORTUNITY

For

**HELI-HYDRANT PROJECT
CITY PROJECT NO. 1-W-23**

_____ Certifies that:
(Contractor)

It has adopted and approved affirmative action plan in compliance with Title VII of the Civil Rights Act and the Equal Employment Opportunity Act of 1972 and agrees to submit a copy of that plan to the Assistant to the City Manager/Personnel of the City of La Habra for inspection prior to the award of contract.

Signed: _____

By: _____

Title: _____

Date: _____

EXHIBIT A
SCOPE OF SERVICES



P.O. Box 605, Brea, CA 92822

Date: 8/12/22
Proposal #81222-1

Estimate for: City of La Habra Water District

Billing Address: 110 E. La Habra Blvd, La Habra, California 90631.

Attn: Brian Jones and Albert Mendoza

Subject: City of La Habra Heli-Hydrant #5

Job Description: Complete Heli-Hydrant installation

Job Address: 1000 W Risner Way, La Habra Ca. 90631

Scope of Work for the Heli-Hydrant Site

Provide a Patented snorkel site tank for Firefighting helicopters, connected to the water supply.
(The Heli-Hydrant)

Payment 20% at Signing, 40% at Heli-hydrant installation, 40% upon field test success.

Over Head \$ 25,908.00
Labor Cost \$ 27,321.00
Material Cost \$ 130,542.00

Total \$ 183,771.00

Site Evaluation and Determination - Completed jointly by Whaling Fire and City of La Habra water
Vehicle Access
Helicopter Access Obstructions
Water supply
Water line size
Head pressure

Site Prep done by City of La Habra Water

Leveled soil and compaction for the tank location

Trench to Electrical

Excavation, and trench for piping and electrical

Electrical pad installation

Site Prep from Glenn Chavez Construction:

6" High x 12 gauge, Galvanized Grade Band (Pre-shipped & furnish).

Installation of Grade band and level

Gravel for grade band

Run Conduit and wire in trench for CLA-VAL Valve, drain valve, and tank lights

Heli-Hydrant Scope of Work / Installation

ONE (1) 8,500 Gallons (Nominal), 1 – Ring, Open Top, Flat Welded Steel Floor, A.W.W.A. D103, Factory Powder Coated, throughout with 5 mil average dry film thickness using Axalta "Tank Tan," a Thermal Set, NSF 61 Approved, Epoxy Powder Coating on Tank Interior and Underside of Floor & 5 mil average dry film thickness using Axalta "Superior Sand," a Thermal Set TGIC Polyester Powder Coating on Tank Exterior, 15'- 4 5/8" Diameter x 8 '(Nominal) High, Bolted Steel Storage Tank, with the following appurtenances: (10 Gauge Shell, - side walls)

1 - 6" 150# Flanged Elbow w/ Riser & Internal Elbow Supply to top of tank with Air gap water drop

2 - 6" 150# Flanged Elbow w/ Riser & Internal Elbow Over flow pipe

1 - Ramp to provide Exit and security for Air gap and overflow out lets

1 - 3" Diameter x 10" Deep Floor Sump (Drain)

1 - Float Valve

1 - 6" CLA-VAL Valve

1 - 2" Drain Valve

1 - Stand alone control cabinet with all necessary items to control Heli-Hydrant with patented communications, 2 sets batteries and solar panels for a redundant power supply.

1 - Powder Coated Steel Cabinet

1 - Set of Approved Tank Drawings

Lot – Nut Covers (External – Shell)

Wind Sock, Solar powered, Lighted

The wind sock will be bench tested and batteries conditioned prior to delivery to site.

Installation by GCC

After installation repair of Grade and Asphalt by City of La Habra Water

Clarifications

1. Glenn Chavez Construction and Whaling Fire line adheres to the rules and regulation of this facility.

2. This proposal only includes the items that have been described in the scope of the work. If any additional items are needed they shall be quoted accordingly and shall be considered a change order.

3. This proposal is valid for 30 days.

4. This quote includes prevailing wages and all taxes.



P.O. Box 605, Brea, CA 92822

Date: 11/3/22
Proposal #11322-1

Estimate for: City of La Habra Water District

Billing Address: 110 1E. La Habra Blvd, La Habra, California 90631.

Attn: Brian Jones and Albert Mendoza
Subject: City of La Habra Heli-Hydrant #1
Job Description: Complete Heli Hydrant installation
Job Address: 1000 W Risner Way, La Habra Ca. 90631

Scope of Work Over excavation and recompacting of the Heli-hydrant site.

1. Remove 440 cubic yards from the site approximately 30 x 50 x 8 feet deep.
2. Remove all dispose of debris that cannot be recompacted into the soil.
3. Call for soils testing to verify competent soil at the bottom of the cut.
4. Moisten and recompact the existing soil in 12inch lifts. Each 12inch lift will be tested by the soils engineer on record.
5. All soils reports and testing to paid by the City of La Habra.

Payment 20% at Signing, 40% upon commencement 40% upon completion.

Over Head \$ 7,300.00
Labor Cost \$ 29,000.00
Material and rental Cost \$ 7,500.00

Total \$43,800.00

Clarifications

1. Glenn Chavez Construction and Whaling Fire line adheres to the rules and regulation of this facility.
2. This proposal only includes the items that have been described in the scope of the work. If any additional items are needed they shall be quoted accordingly and shall be considered a change order.
3. This proposal is valid for 30 days.
4. This quote includes prevailing wages and all taxes.

ORIENTATION NOTE:
ORIENTATION FOR NOZZLES AND ACCESSORIES
ARE TO BE FIELD LOCATED BY OWNER.

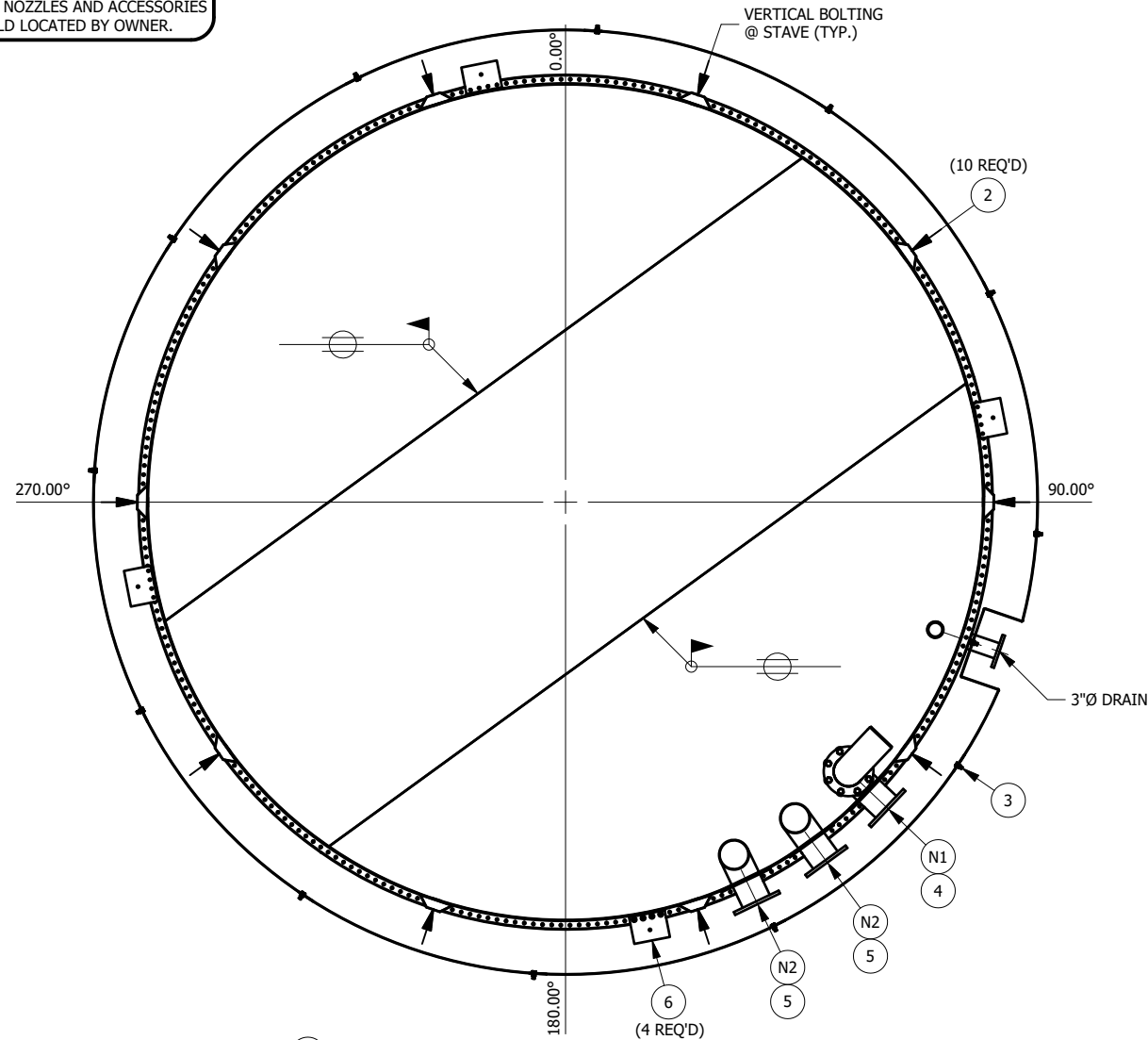

PLAN ORIENTATION
N.T.S.

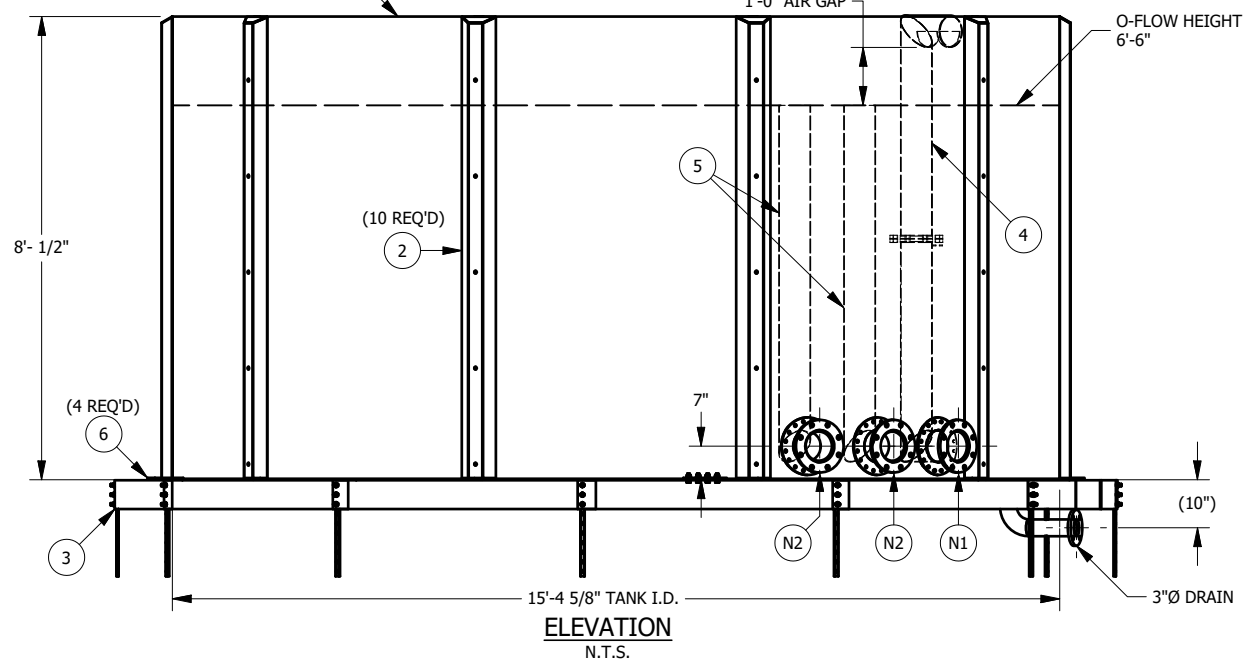

ELEVATION
N.T.S.

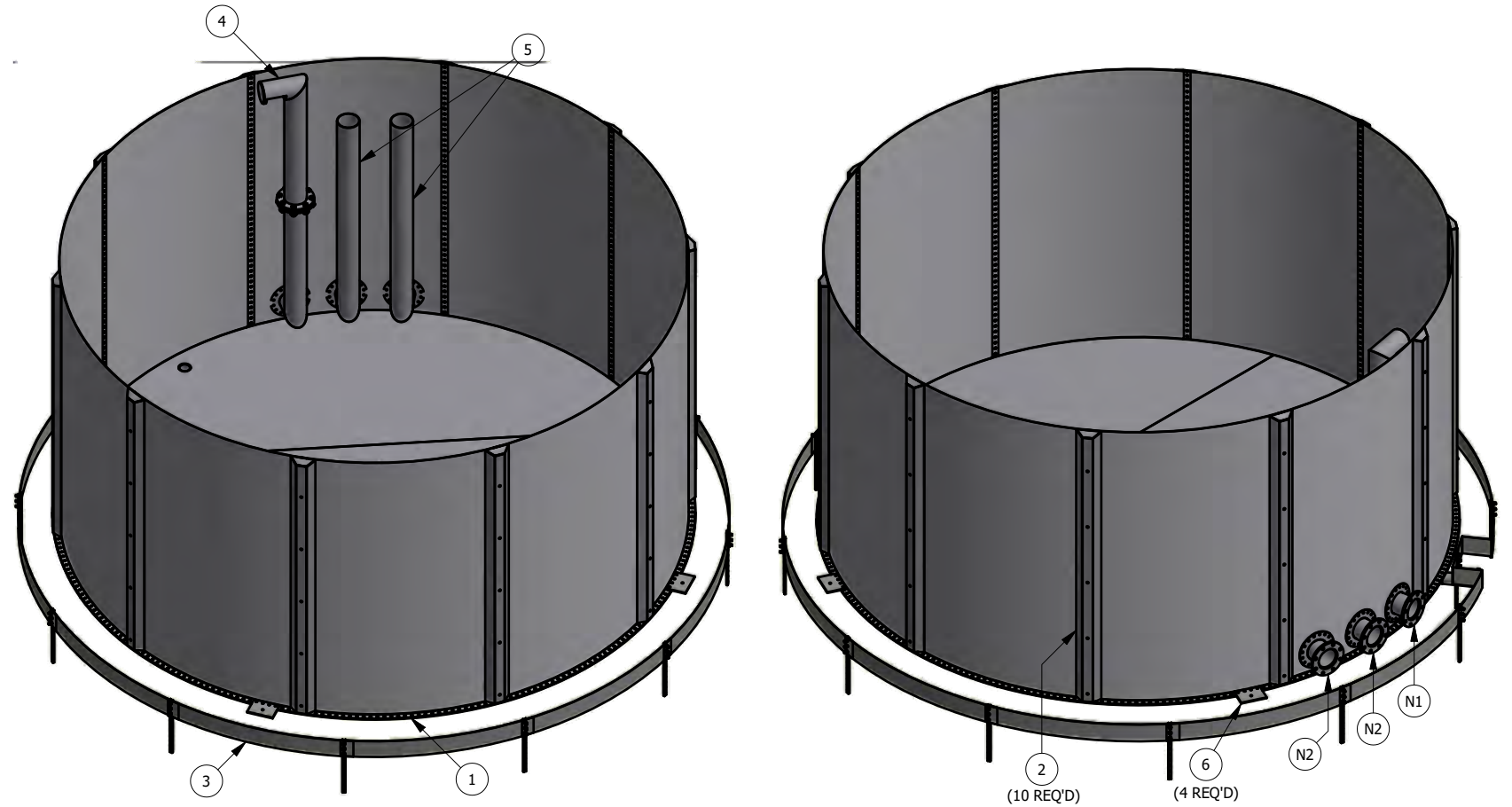

COATING SCHEDULE:

- EXTERIOR COATING OF TANK & ACCESSORIES TO BE FUSION BONDED BAKED-ON POWDER POLYESTER 3 MILS. D.F.T. COLOR: "AXALTA OR EQUAL" SKY WHITE #PFW-510-S9 w/PRIMER @ 2 MILS D.F.T. FOR A TOTAL OF 5 MILS D.F.T. (SAME COLOR AS INTERIOR)
- INTERIOR COATING OF TANK & ACCESSORIES TO BE FUSION BONDED BAKED-ON POWDER EPOXY 5 MILS. MIN. D.F.T. (N.S.F. 61 APPROVED) COLOR: "AXALTA OR EQUAL" APPLIANCE WHITE #ELW-505-S9, UNLESS OTHERWISE NOTED.

GENERAL NOTES:

- TANK TO BE FABRICATED IN ACCORDANCE W/ A.W.W.A. D103-19 & FACTORY-COATED IN ACCORDANCE W/ A.W.W.A D103-19 SECT. 12.6.
- ALL BOLTS & NUTS UNLESS OTHERWISE NOTED SHALL BE GALV. -BOLTS TO BE GRADE 5. **BOLTS & NUTS INSIDE TANK TO BE ENCAPSULATED W/ STRUCTURAL BOLTS & NUTS TO BE (GALV.)**
- TANK BOTTOM TO BE VACUUM TESTED PRIOR TO WATER TEST.
- ONE DEGREE OF ARC TAKEN ON SHELL O.D. = 1 5/8"
- ALL HOLES TO BE Ø9/16" BEFORE GALVANIZING OR COATING, Ø17/32" FINISHED w/TOLERANCE ON BOLT HOLE SPACING TO BE ±1/32" BETWEEN ANY TWO HOLES MEASURED IN THE FLAT BEFORE FORMING.
- ALL TANK OPENINGS TO BE FIELD LOCATED.
- PIPING FLEXIBILITY MEETING THE REQUIREMENTS OF AWWA D103-19 SECTION 14.5 SHALL BE PROVIDED (BY OTHERS).

PROJECT:
GLENN CHAVEZ CONSTRUCTION
LA HABRA HEIGHTS, Ca

THIS DRAWING IS THE EXCLUSIVE PROPERTY OF SUPERIOR TANK COMPANY INC. WHO HOLDS AND MAINTAINS FULL COPYRIGHT PROTECTION UNDER FEDERAL AND STATE LAW. THIS DRAWING CANNOT BE DUPLICATED PHOTOCOPIED DIGITALLY TRANSFERRED, OR REPRODUCED WITHOUT THE EXPRESS WRITTEN CONSENT OF SUPERIOR TANK COMPANY INC.

ITEM	PART NUMBER	DESCRIPTION	QTY	UOM
N1,N2	9022-022-002	NOZZLE, SHELL 6"-150# F.F. w/ 6" PROJ., 3/16" THK REPAD (FPC)	3	EA
7	15980R-HWK	HARDWARE KIT ACCESSORIES, 15980R	1	EA
6	9977-465-299	TAB PLATE ASSY, 6" x 8", 5/16" THK. w/ 9/16"Ø HOLE, (4) 9/16"Ø HOLES, 15'-4 5/8"Ø TANK (FPC)	4	EA
5	9054-830-002	O-FLOW WLDMT, 6"Ø SCH. 10, 6" x 5'-11" w/ 90° MITER (FPC)	2	EA
4	9047-998-002	INLET RISER WLDMT, 6"Ø SCH. 10 PIPE, 6" x 7'-2 3/8" w/ MITER ELBOW (FPC)	1	EA
3	9027-542-003	GRADE BAND ASSY., 17'-4 5/8" DIA x 6" HIGH 12 GA. w/ OPENING FOR DRAIN NOZZLE (GALV.)	1	EA
2	9055-002-002	SIDE BOLT COVER WLDMT, 2 1/4" x 8'-0" LG. (FPC)	10	EA
1	1508-021-002	15'-4 5/8" DIA x 8'-0 1/2" HIGH BOLTED STEEL TANK, AWWA D103-19 (ENCAP)(NO TOP CHIME)(FPC)	1	EA

CUSTOMER:		APPROVALS		DATE	TITLE:	SCALE:	PART#	SHEET:
UNLESS OTHERWISE SPECIFIED, DIMENSIONS ARE INCHES. TOLERANCES ARE:		DRAWN BY:	DATE					
FRACTIONS:	DECIMALS:	ANGLES:						
MATERIAL:		CHECKED:	DATE		PROJECT:			
FINISH:		APPROVED:	DATE		GLENN CHAVEZ CONSTRUCTION			
DO NOT SCALE DRAWING		JOB#			15980R			



9500 LUCAS RANCH RD.
RANCHO CUCAMONGA, CA. 91730
Phone: (909) 912-0580
Fax: (909) 912-0585

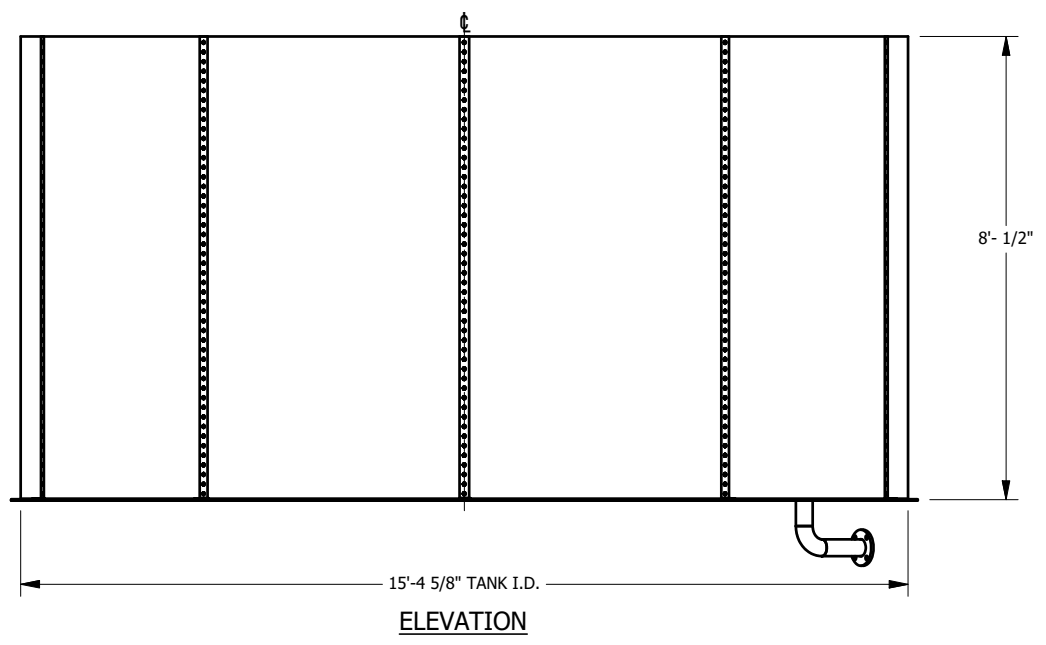
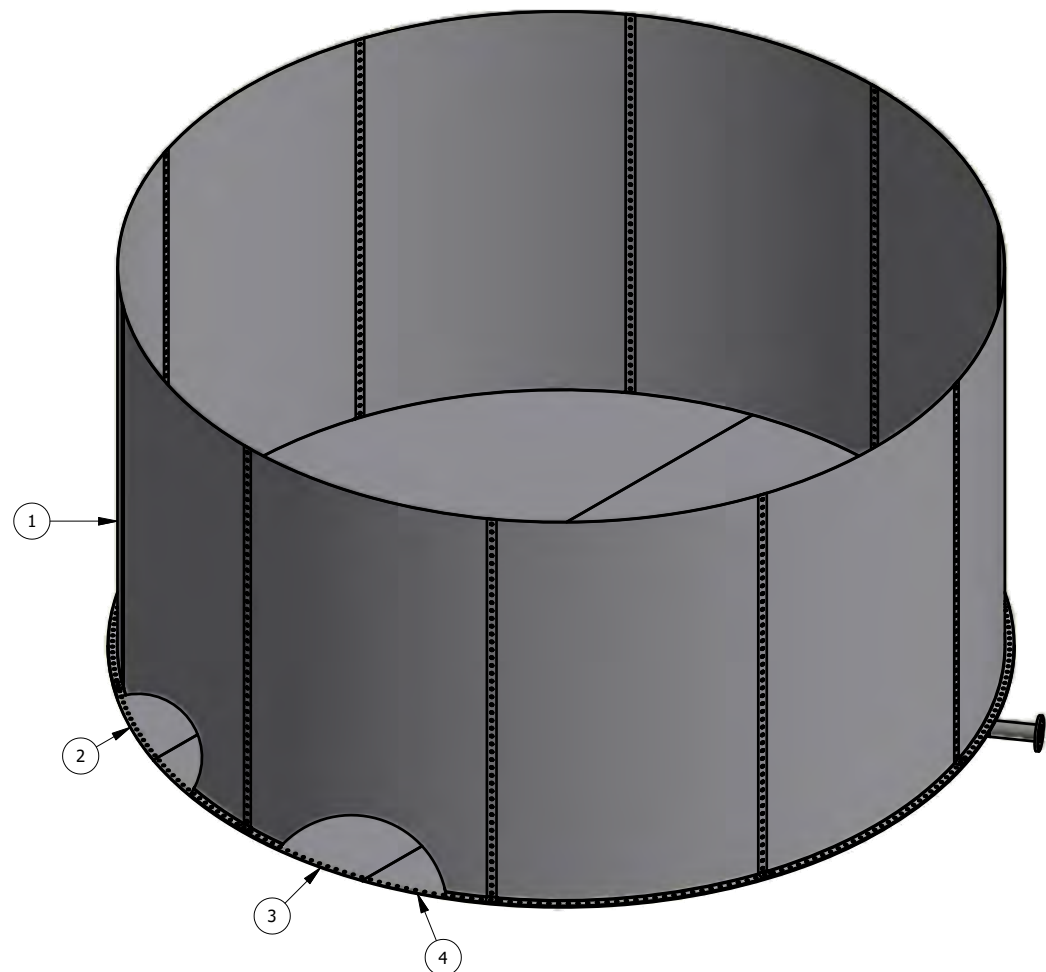
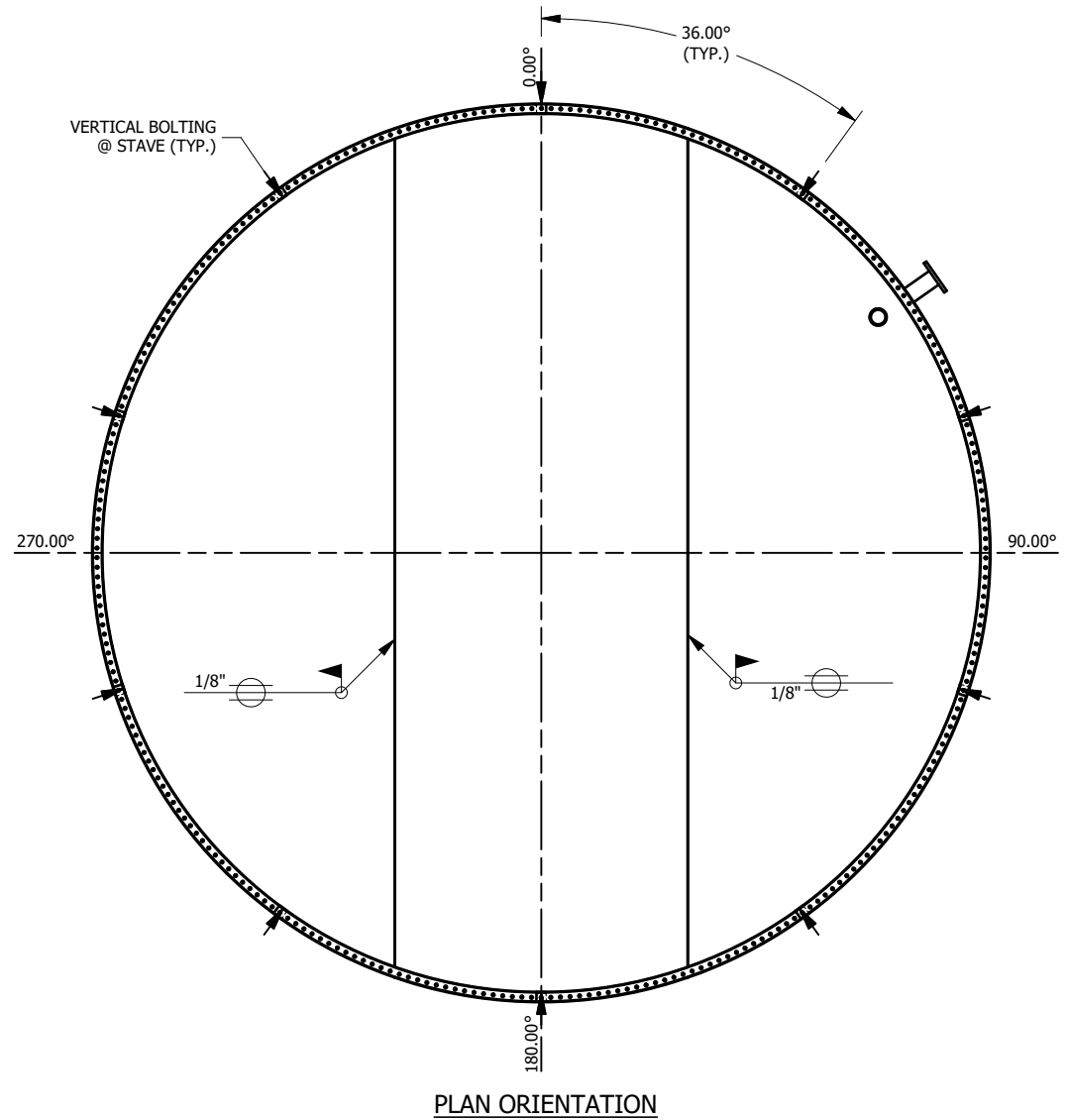

ITEM	PART NUMBER	DESCRIPTION	QTY	UOM
5	1508-021-HWK	HARDWARE KIT, 15'-4 5/8" DIA TANK x 8'-0 1/2" (ENCAP) (AWWA)	1	EA
4	1501-019-001	15'-4 5/8"Ø, SQ. BTM, CANT 1, 3/16" THK. w/ 3"Ø DRAIN NOZZLE (SPECIAL)	1	EA
3	1501-016-199	15'-4 5/8"Ø, SQ. BTM, CANT 2, 3/16" THK., SPECIAL	1	EA
2	1501-015-199	15'-4 5/8"Ø, SQ. BTM, CANT 1, 3/16" THK., SPECIAL	1	EA
1	1504-039-199	15'-4 5/8"Ø, 12 GA., GR.40, SR, 60" STAVE (8'-0 1/2") (NO TOP CHIME)	10	EA

BILL OF MATERIALS

UNLESS OTHERWISE SPECIFIED, DIMENSIONS ARE INCHES. TOLERANCES ARE:		CUSTOMER:		<p>9500 LUCAS RANCH RD. RANCHO CUCAMONGA, CA. 91730 Phone: (909) 912-0580 Fax: (909) 912-0585</p>
FRACTIONS:	DECIMALS:	APPROVALS	DATE	
		DRAWN BY: Ronnie E.	8/6/2021	<p>TITLE: 15'-4 5/8" DIA x 8'-0 1/2" HIGH BOLTED STEEL TANK, AWWA D103-19 (ENCAP)(NO TOP CHIME)(FPC)</p> <p>SIZE: PROJECT: REV:</p>
MATERIAL:		CHECKED: MG	8/10/2021	
FINISH:		APPROVED: MG	8/10/2021	SCALE: PART#
DO NOT SCALE DRAWING		JOB#		1508-021-002

THIS DRAWING IS THE EXCLUSIVE PROPERTY OF SUPERIOR TANK COMPANY INC. WHO HOLDS AND MAINTAINS FULL COPYRIGHT PROTECTION UNDER FEDERAL AND STATE LAW. THIS DRAWING CANNOT BE DUPLICATED, PHOTOCOPIED, DIGITALLY TRANSFERRED, OR REPRODUCED WITHOUT THE EXPRESS WRITTEN CONSENT OF SUPERIOR TANK COMPANY INC.

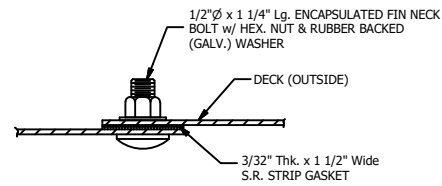

SECTION A-A
DECK SEAM LAP

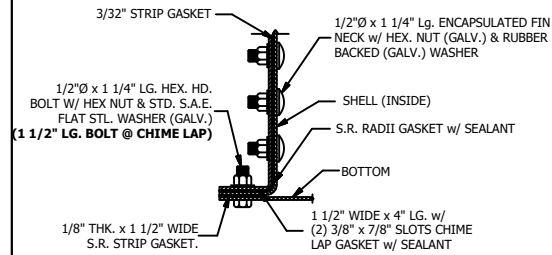

SECTION B-B
CHIME BOLTING @ BOTTOM

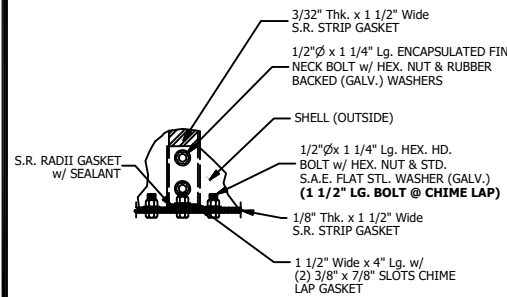

VIEW C
S.R. STAVE LAP

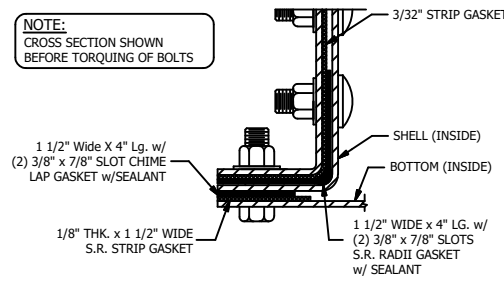

GASKET SECTION B-1
N.T.S.

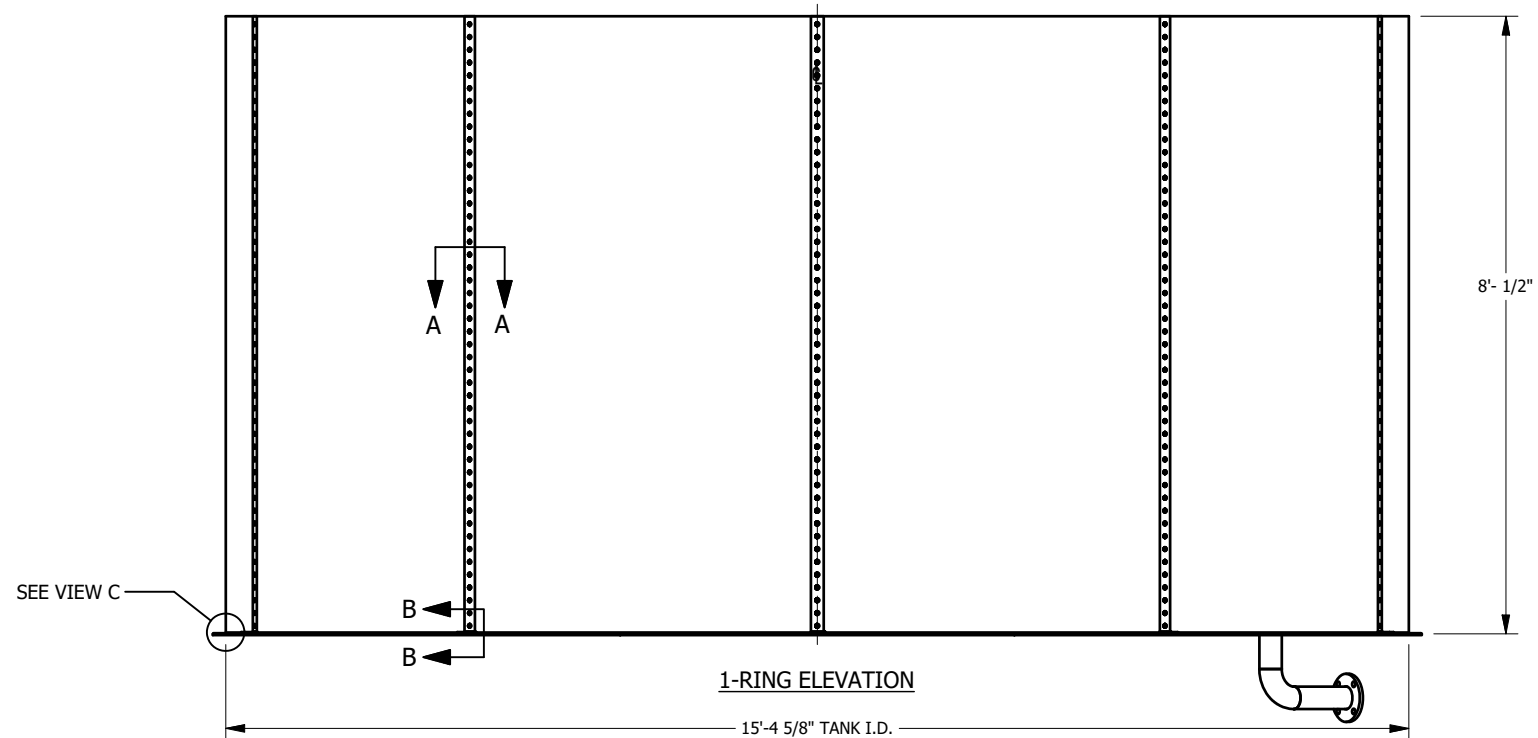

- NOTES:
1. ALL RADII, CHIME LAP, STRIP GASKETS TO BE E.P.D.M. RUBBER MATERIAL (F.D.A. APPROVED).
 2. UNLESS OTHERWISE SPECIFIED, HEX HEAD BOLTS OF SIMILAR GRADE W/ BACK UP CHANNEL MAY BE USED IN LIEU OF FIN NECK BOLTS AT THE MANUFACTURER'S DISCRETION.
 3. ALL TANK BOLTS SPACING TO BE @ 2" c/c.

		9500 LUCAS RANCH RD. RANCHO CUCAMONGA, CA. 91730 Phone: (909) 912-0580 Fax: (909) 912-0585	
		TITLE: 15'-4 5/8" DIA x 8'-0 1/2" HIGH BOLTED STEEL TANK, AWWA D103-19 (ENCAP)(NO TOP CHIME)(FPC)	
SIZE:	PROJECT:	REV:	
B			
SCALE:	PART#	SHEET:	
	1508-021-002	2 OF 2	

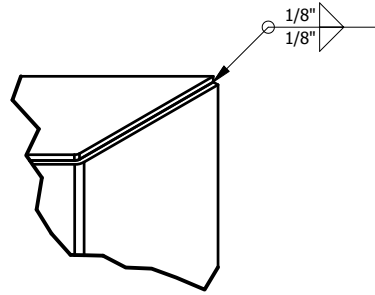
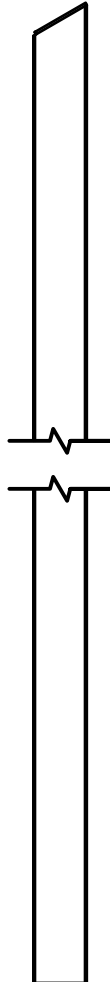
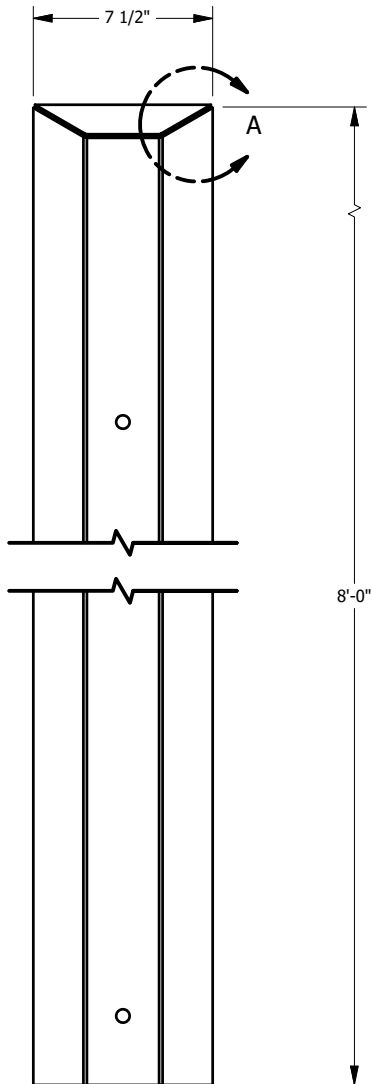
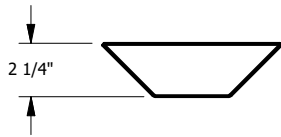

DETAIL A
N.T.S.

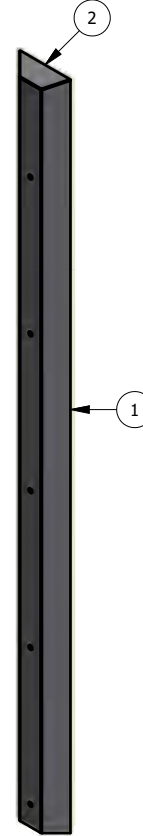

ITEM	PART NUMBER	DESCRIPTION	QTY	UOM
2	9979-641-199	SIDE BOLT COVER, CAP PLATE, 12 GA., 2 1/4" x 7 5/16"	1	EA
1	9977-461-199	SIDE BOLT COVER, BENT PLATE, 12 GA., 2 1/4" x 8'-0" LG.	1	EA

BILL OF MATERIALS

UNLESS OTHERWISE SPECIFIED, DIMENSIONS ARE INCHES. TOLERANCES ARE:			CUSTOMER:		 9500 LUCAS RANCH RD. RANCHO CUCAMONGA, CA. 91730 Phone: (909) 912-0580 Fax: (909) 912-0585
FRACTIONS:	DECIMALS:	ANGLES:	APPROVALS	DATE	
MATERIAL:			DRAWN BY:	8/9/2021	TITLE: SIDE BOLT COVER WLDMT, 2 1/4" x 8'-0" LG.
FINISH:			CHECKED:	8/10/2021	
DO NOT SCALE DRAWING			APPROVED:	8/10/2021	SIZE: PROJECT: A
			JOB#		SCALE: PART# 9055-002-001
					SHEET: 1 OF 1

THIS DRAWING IS THE EXCLUSIVE PROPERTY OF SUPERIOR TANK COMPANY INC. WHO HOLDS AND MAINTAINS FULL COPYRIGHT PROTECTION UNDER FEDERAL AND STATE LAW. THIS DRAWING CANNOT BE DUPLICATED PHOTOCOPIED DIGITALLY TRANSFERRED, OR REPRODUCED WITHOUT THE EXPRESS WRITTEN CONSENT OF SUPERIOR TANK COMPANY INC.

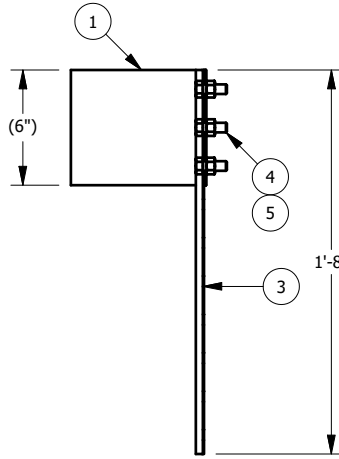
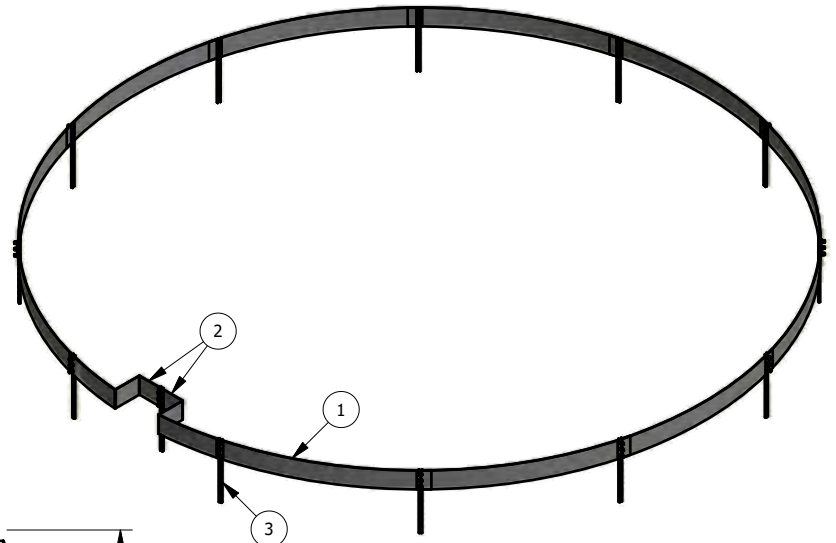
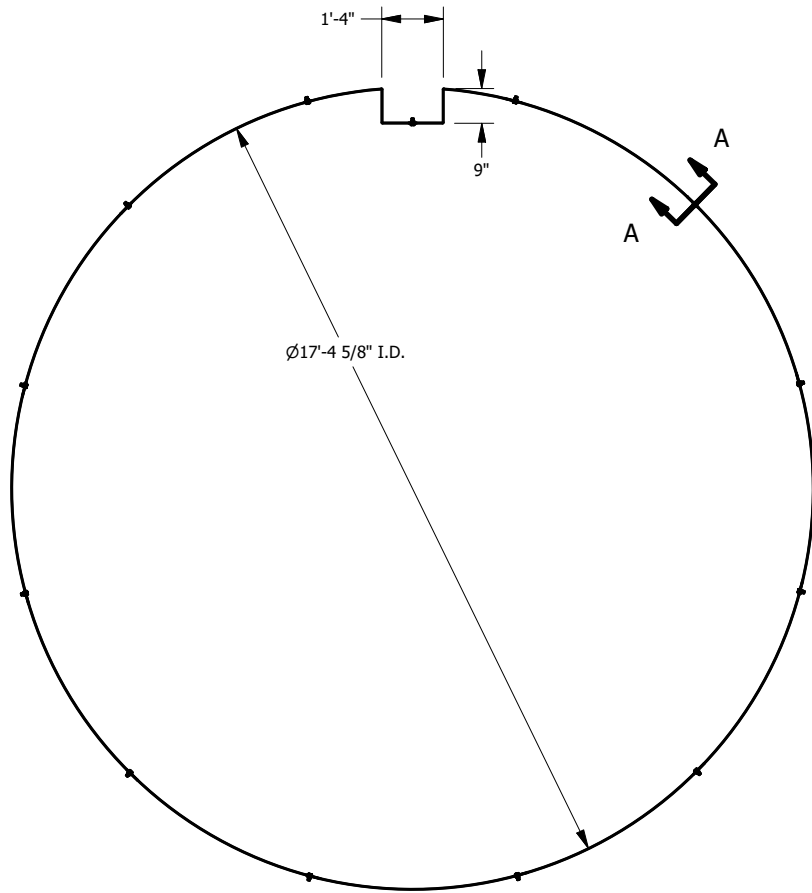

SECTION A-A

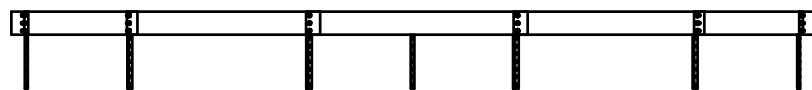

ITEM	PART NUMBER	DESCRIPTION	QTY	UOM
5	0800-001-000	1/2" -13 HDG HEX NUTS GRADE 5 OVER TAPPED 0.015"	39	EA
4	0100-002-000	1/2"-13 X 1 1/4" GALV. HEX HD BOLTS GR.5	39	EA
3	9999-901-199	BACKUP CHANNEL, 10 HOLE, 1'-8" LG.	13	EA
2	9977-090-199	GRADE BAND 12Ga., 6" x 3'-2 3/8", BEND PLATE	2	EA
1	9998-817-199	GRADE BAND, 12 GA x 6" x 5'-0" w/ 58" c/c HOLES x 17'-4 5/8" I.D. (GALV.)	11	EA

BILL OF MATERIALS

UNLESS OTHERWISE SPECIFIED, DIMENSIONS ARE INCHES. TOLERANCES ARE:			CUSTOMER:		 9500 LUCAS RANCH RD. RANCHO CUCAMONGA, CA. 91730 Phone: (909) 912-0580 Fax: (909) 912-0585
FRACTIONS:	DECIMALS:	ANGLES:	APPROVALS	DATE	
MATERIAL:			DRAWN BY:	6/29/2011	TITLE: GRADE BAND ASSY., 17'-4 5/8" DIA x 6" HIGH 12 GA. w/ OPENING FOR DRAIN NOZZLE
FINISH:			CHECKED:	5/20/2021	
DO NOT SCALE DRAWING			APPROVED:	5/20/2021	SIZE: PROJECT: A
			JOB#		SCALE: PART# 9027-542-001 SHEET: 1 OF 1

THIS DRAWING IS THE EXCLUSIVE PROPERTY OF SUPERIOR TANK COMPANY INC. WHO HOLDS AND MAINTAINS FULL COPYRIGHT PROTECTION UNDER FEDERAL AND STATE LAW. THIS DRAWING CANNOT BE DUPLICATED PHOTOCOPIED DIGITALLY TRANSFERRED, OR REPRODUCED WITHOUT THE EXPRESS WRITTEN CONSENT OF SUPERIOR TANK COMPANY INC.

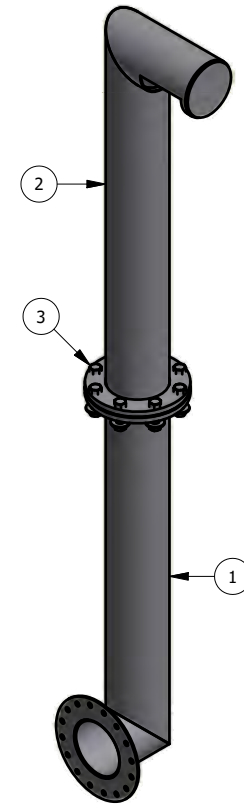
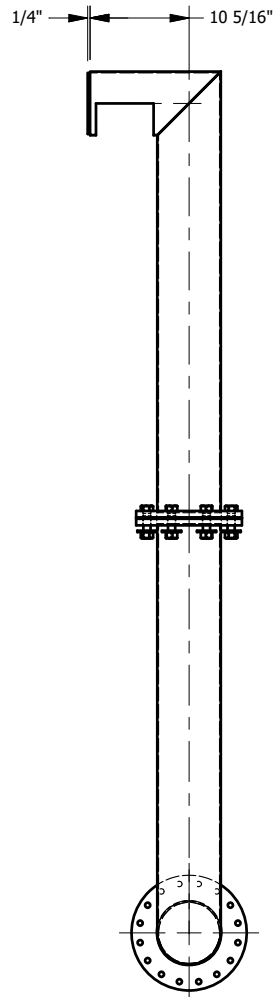
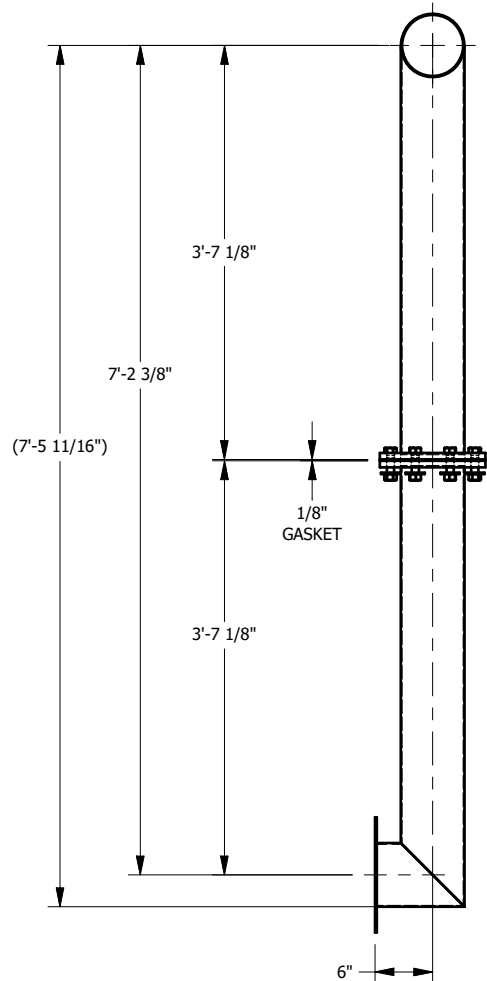
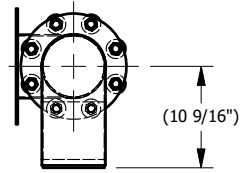

ITEM	PART NUMBER	DESCRIPTION	QTY	UOM
3	9020-003-001	FLANGE BOLT KIT, 6"-150# CLASS D	1	EA
2	9047-999-001	INLET RISER WLDMT, 6"Ø SCH. 10 PIPE, 10 7/16" x 3'-7 1/8" w/ MITER ELBOW & 150# FLG.	1	EA
1	9057-001-001	INLET RISER WLDMT, 6"Ø SCH. 10 PIPE, 6" x 3'-7 1/8" w/ MITER ELBOW & (1) 150# FLG.	1	EA

BILL OF MATERIALS

UNLESS OTHERWISE SPECIFIED, DIMENSIONS ARE INCHES. TOLERANCES ARE:			CUSTOMER:		 9500 LUCAS RANCH RD. RANCHO CUCAMONGA, CA. 91730 Phone: (909) 912-0580 Fax: (909) 912-0585
FRACTIONS:	DECIMALS:	ANGLES:	APPROVALS	DATE	
MATERIAL:			DRAWN BY:	8/9/2021	TITLE: INLET RISER WLDMT, 6"Ø SCH. 10 PIPE, 6" x 7'-2 3/8" w/ MITER ELBOW
FINISH:			CHECKED:	8/10/2021	
DO NOT SCALE DRAWING			APPROVED:	8/10/2021	SIZE: PROJECT: A
			JOB#		SCALE: PART# 9047-998-001
					SHEET: 1 OF 1

THIS DRAWING IS THE EXCLUSIVE PROPERTY OF SUPERIOR TANK COMPANY INC. WHO HOLDS AND MAINTAINS FULL COPYRIGHT PROTECTION UNDER FEDERAL AND STATE LAW. THIS DRAWING CANNOT BE DUPLICATED PHOTOCOPIED DIGITALLY TRANSFERRED, OR REPRODUCED WITHOUT THE EXPRESS WRITTEN CONSENT OF SUPERIOR TANK COMPANY INC.

1. GRIND SHARP EDGES DOWN.

NOTES:

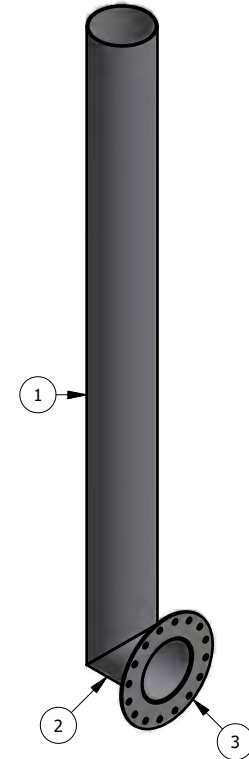
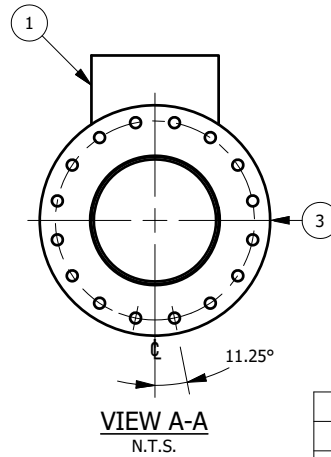
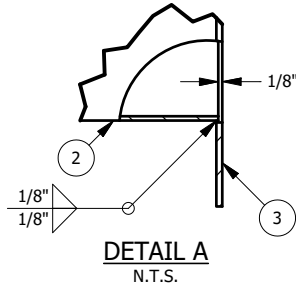
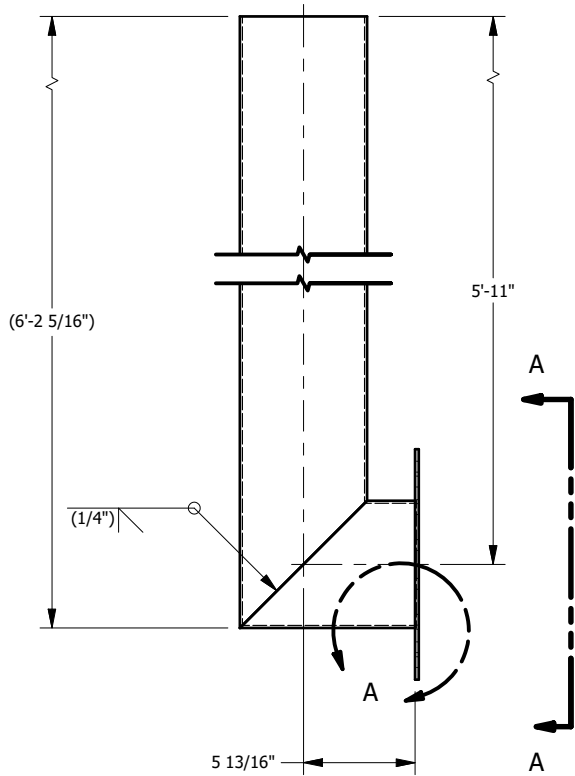
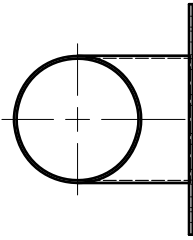

3	9999-144-199	FLANGE, 6 3/4" I.D., 12" O.D., 3/16" Thk. 16 HOLES	1	EA
2	9977-462-199	MITER, PIPE, 6"Ø SCH. 10 x 9 3/16" LG., A53B	1	EA
1	9977-455-199	MITER, PIPE, 6"Ø SCH. 10 x 6'-2 5/16" LG., A53B	1	EA
ITEM	PART NUMBER	DESCRIPTION	QTY	UOM

BILL OF MATERIALS

UNLESS OTHERWISE SPECIFIED, DIMENSIONS ARE INCHES. TOLERANCES ARE:			CUSTOMER:		 9500 LUCAS RANCH RD. RANCHO CUCAMONGA, CA. 91730 Phone: (909) 912-0580 Fax: (909) 912-0585
FRACTIONS:	DECIMALS:	ANGLES:	APPROVALS	DATE	
MATERIAL:			DRAWN BY:	8/9/2021	TITLE: O-FLOW WLDMT, 6"Ø SCH. 10, 6" x 5'-11" w/ 90° MITER
FINISH:			CHECKED:	8/10/2021	
DO NOT SCALE DRAWING			APPROVED:	8/10/2021	SIZE: A PROJECT: REV:
			JOB#	SCALE:	PART# 9054-830-001 SHEET: 1 OF 1

THIS DRAWING IS THE EXCLUSIVE PROPERTY OF SUPERIOR TANK COMPANY INC. WHO HOLDS AND MAINTAINS FULL COPYRIGHT PROTECTION UNDER FEDERAL AND STATE LAW. THIS DRAWING CANNOT BE DUPLICATED, PHOTOCOPIED, DIGITALLY TRANSFERRED, OR REPRODUCED WITHOUT THE EXPRESS WRITTEN CONSENT OF SUPERIOR TANK COMPANY INC.

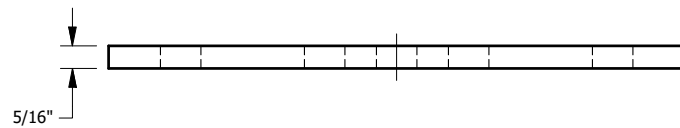
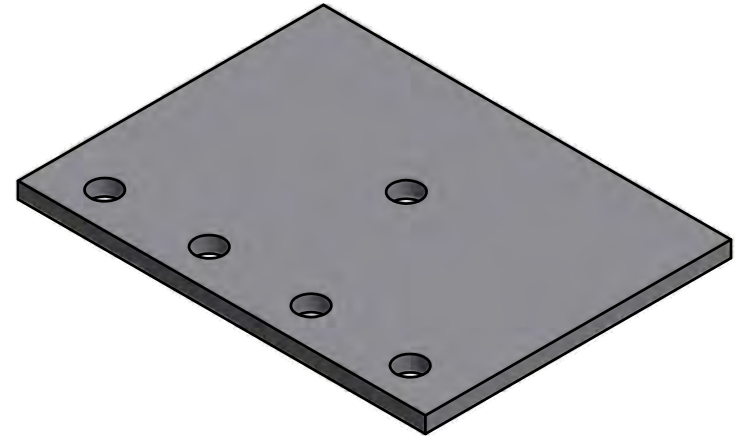
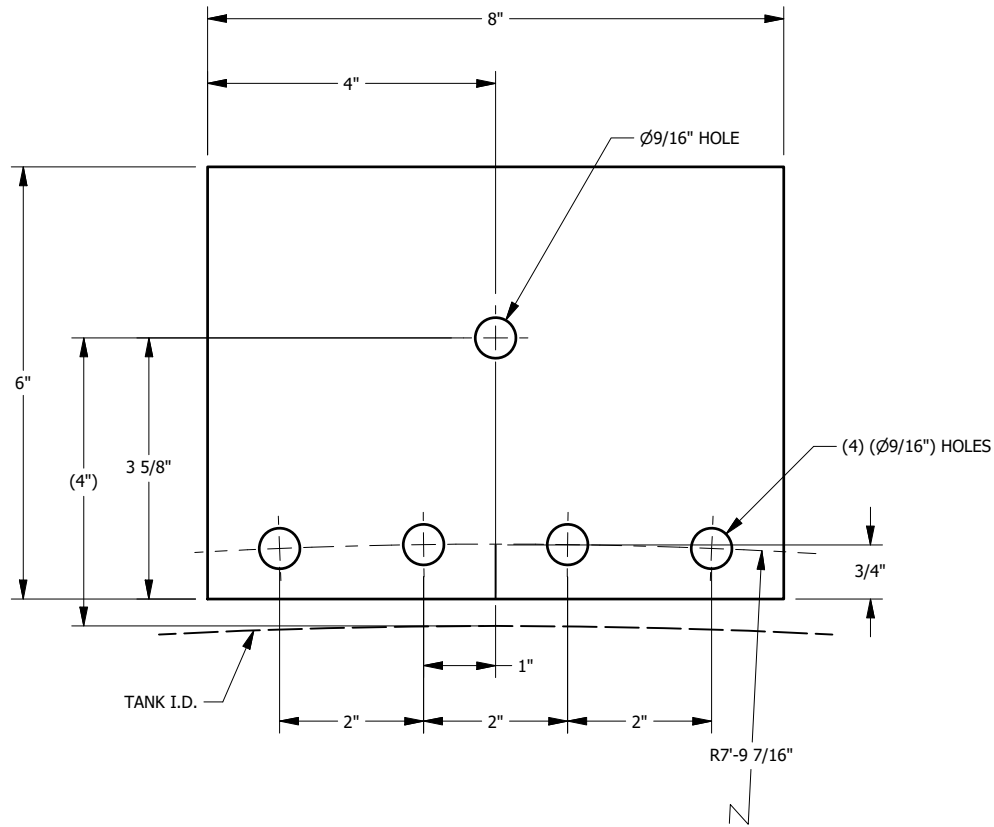

1. GRIND SHARP EDGES DOWN.

NOTES:

THIS DRAWING IS THE EXCLUSIVE PROPERTY OF SUPERIOR TANK COMPANY INC. WHO HOLDS AND MAINTAINS FULL COPYRIGHT PROTECTION UNDER FEDERAL AND STATE LAW. THIS DRAWING CANNOT BE DUPLICATED, PHOTOCOPIED, DIGITALLY TRANSFERRED, OR REPRODUCED WITHOUT THE EXPRESS WRITTEN CONSENT OF SUPERIOR TANK COMPANY INC.

1	P200-011-000	PLATE A-36, 5/16" THK X 72" X 120"	0.006	EA	
ITEM	PART NUMBER	DESCRIPTION	QTY	UOM	
BILL OF MATERIALS					
UNLESS OTHERWISE SPECIFIED, DIMENSIONS ARE INCHES. TOLERANCES ARE:		CUSTOMER:			
FRACTIONS:	DECIMALS:	ANGLES:	 9500 LUCAS RANCH RD. RANCHO CUCAMONGA, CA. 91730 Phone: (909) 912-0580 Fax: (909) 912-0585		
APPROVALS					DATE
DRAWN BY:					8/9/2021
CHECKED:					8/10/2021
MATERIAL:		APPROVED:			
AS NOTED		MG			
FINISH:		8/10/2021			
JOB#		TITLE: TAB PLATE ASSY, 6" x 8", 5/16" THK. w/ 9/16"Ø HOLE, (4) 9/16"Ø HOLES, 15'-4 5/8"Ø TANK			
DO NOT SCALE DRAWING		SCALE:	PART#	SHEET:	
		A	9977-465-199	1 OF 1	
		STANDARD DRAWING			

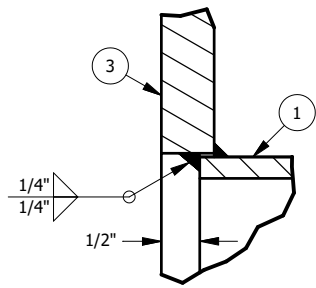

DETAIL B

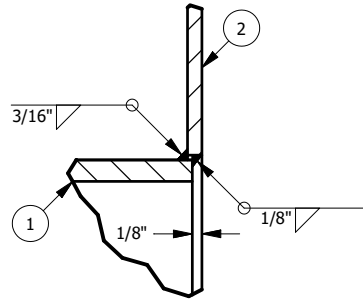

DETAIL C

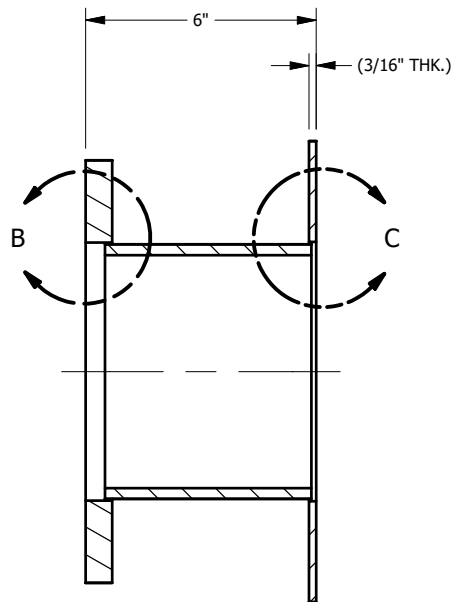
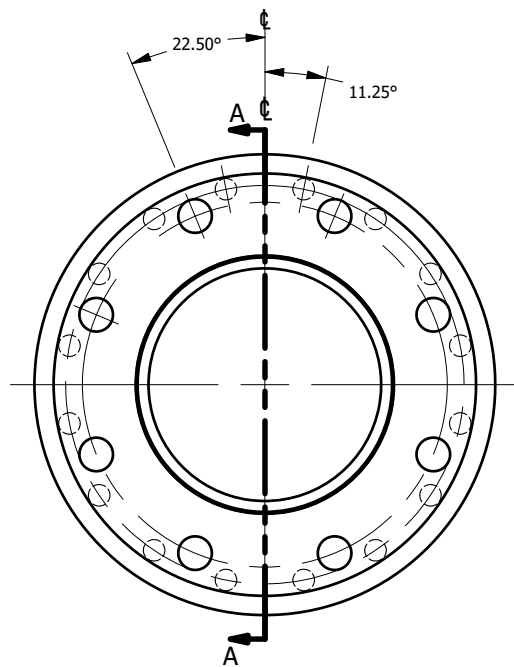

SECTION A-A

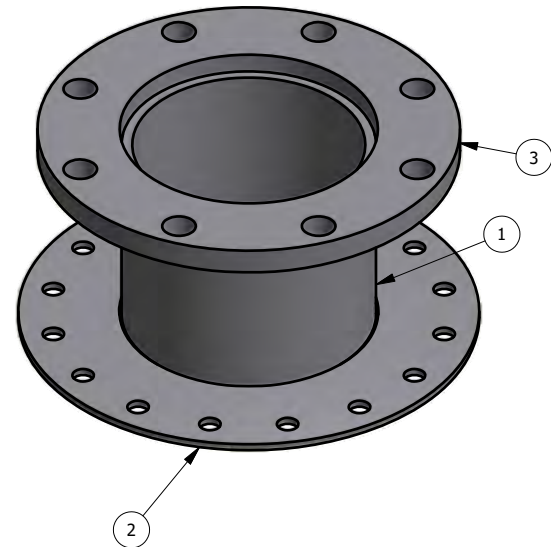

ITEM	PART NUMBER	DESCRIPTION	QTY	UOM
3	F006-001-000	FLANGE, 6"-150# F.F. AWWA C207-01 CLASS "D"	1	EA
2	9999-144-199	FLANGE, 6 3/4" I.D., 12" O.D., 3/16" Thk. 16 HOLES	1	EA
1	9999-143-199	PIPE, 6"Ø STD. WT. X 5 3/8" LG.	1	EA

BILL OF MATERIALS

UNLESS OTHERWISE SPECIFIED, DIMENSIONS ARE INCHES. TOLERANCES ARE:		CUSTOMER:			9500 LUCAS RANCH RD. RANCHO CUCAMONGA, CA. 91730 Phone: (909) 912-0580 Fax: (909) 912-0585
FRACTIONS:	DECIMALS:	ANGLES:	APPROVALS		
MATERIAL:		DRAWN BY:		TITLE:	
FINISH:		CHECKED:		NOZZLE, SHELL, 6"-150# F.F. w/ 6" PROJ., 3/16" THK REPAD	
JOB#		APPROVED:		SIZE:	PROJECT:
DO NOT SCALE DRAWING		J. JONES		A	STANDARD DRAWING
		BB		SCALE:	REV:
		4/2/2008		PART#	9022-022-001
				SHEET: 1 OF 1	

THIS DRAWING IS THE EXCLUSIVE PROPERTY OF SUPERIOR TANK COMPANY INC. WHO HOLDS AND MAINTAINS FULL COPYRIGHT PROTECTION UNDER FEDERAL AND STATE LAW. THIS DRAWING CANNOT BE DUPLICATED PHOTOCOPIED DIGITALLY TRANSFERRED, OR REPRODUCED WITHOUT THE EXPRESS WRITTEN CONSENT OF SUPERIOR TANK COMPANY INC.

NOTES:

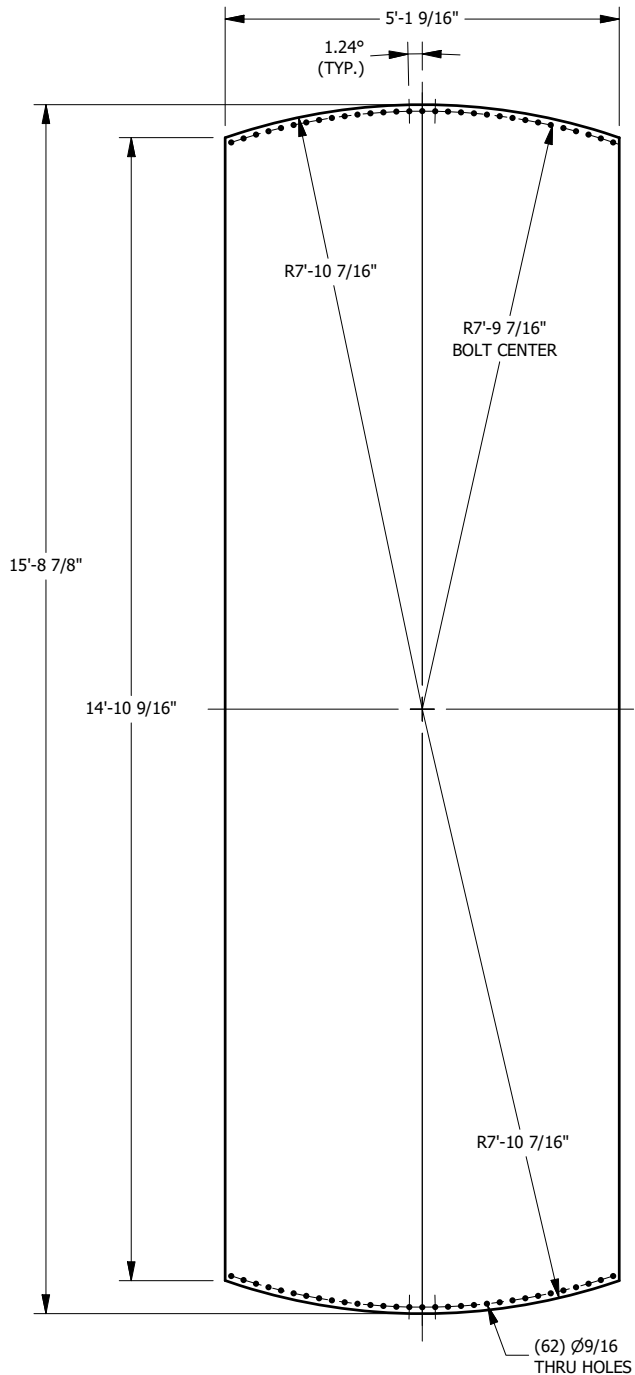

3/16" THK.

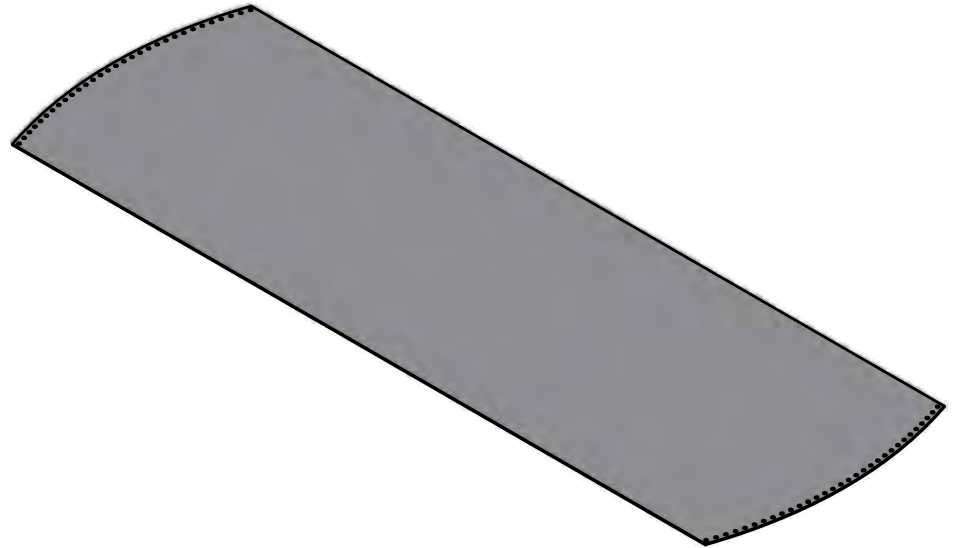

1. GRIND SHARP EDGES DOWN.

NOTES:

THIS DRAWING IS THE EXCLUSIVE PROPERTY OF SUPERIOR TANK COMPANY INC. WHO HOLDS AND MAINTAINS FULL COPYRIGHT PROTECTION UNDER FEDERAL AND STATE LAW. THIS DRAWING CANNOT BE DUPLICATED PHOTOCOPIED DIGITALLY TRANSFERRED, OR REPRODUCED WITHOUT THE EXPRESS WRITTEN CONSENT OF SUPERIOR TANK COMPANY INC.

1	B002-042-000	3/16", A-36, 72" x 189" w/ LASERED HOLES , REFERENCE DRAWING FOR DIMENSIONS	1	EA	
ITEM	PART NUMBER	DESCRIPTION	QTY	UOM	
BILL OF MATERIALS					
UNLESS OTHERWISE SPECIFIED, DIMENSIONS ARE INCHES. TOLERANCES ARE:		CUSTOMER:			
FRACTIONS:	DECIMALS:	ANGLES:	 9500 LUCAS RANCH RD. RANCHO CUCAMONGA, CA. 91730 Phone: (909) 912-0580 Fax: (909) 912-0585		
APPROVALS					DATE
DRAWN BY:					4/1/2021
CHECKED:					4/2/2021
MATERIAL:		APPROVED:	TITLE:		
		MG	15'-4 5/8"Ø, SQ. BTM, CANT 2, 3/16" THK., SPECIAL		
FINISH:		MG	SIZE:	PROJECT:	
		MG	A		
JOB #		DATE:	SCALE:	REV:	
		4/2/2021			
DO NOT SCALE DRAWING		PART#	SHEET:		
		1501-016-199	1 OF 1		

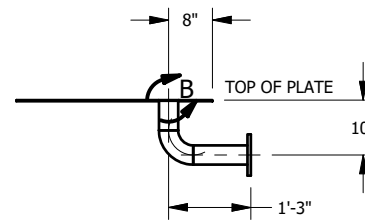
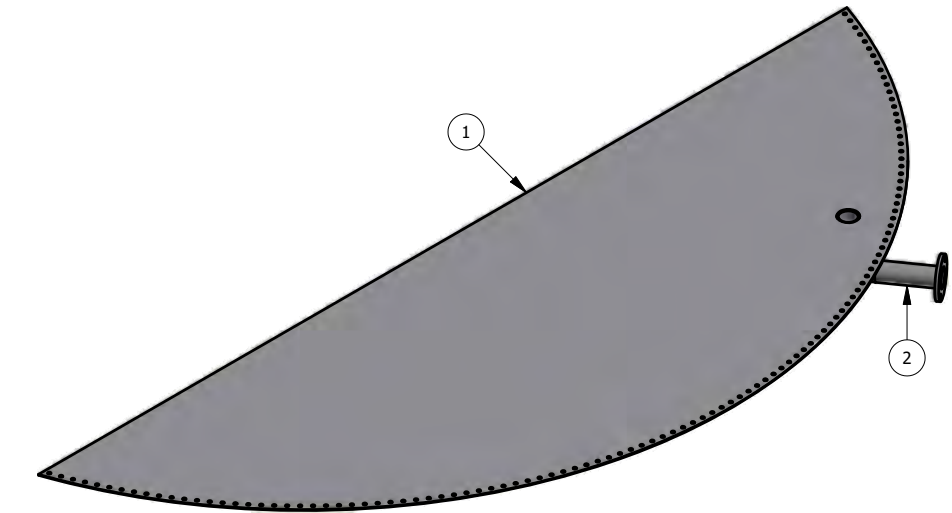
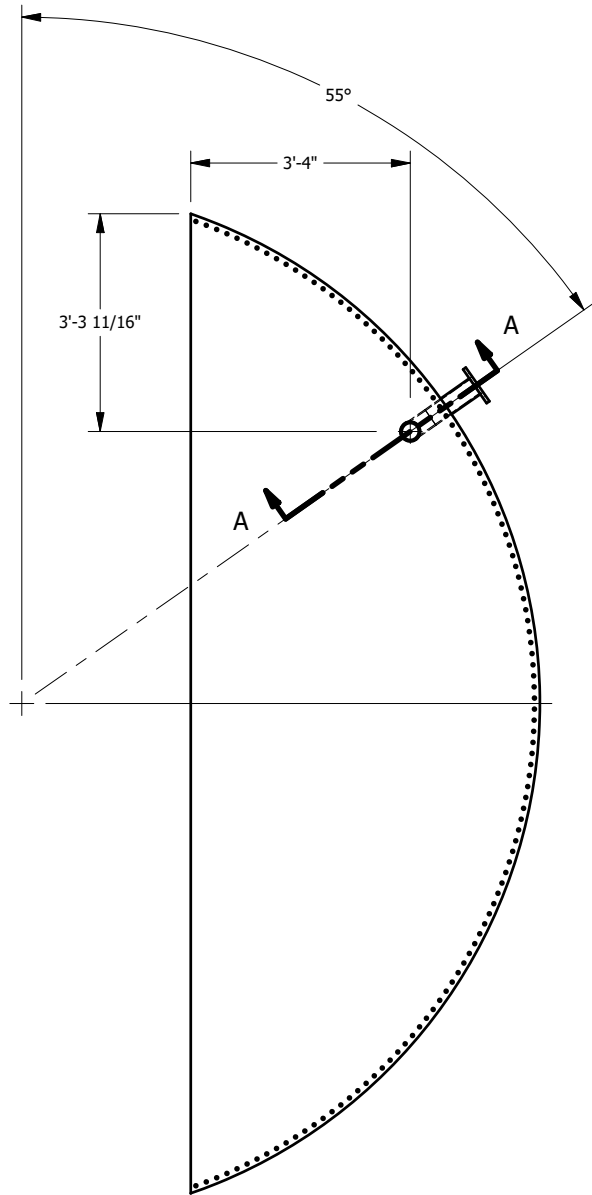

SECTION A-A
N.T.S.

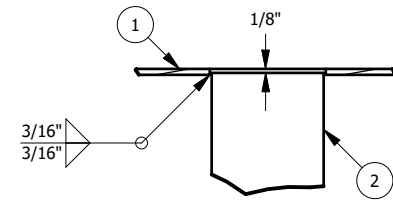

DETAIL B
N.T.S.

2	9047-846-001	DRAIN WLDMT, 3"Ø STD. WT. PIPE, 10" x 1'-3" w/ 90° LR ELBOW	1	EA
1	1501-018-199	15'-4 5/8"Ø, SQ. BTM, CANT 1, 3/16" THK. w/ 3 5/8"Ø HOLE (SPECIAL)	1	EA
ITEM	PART NUMBER	DESCRIPTION	QTY	UOM

BILL OF MATERIALS

UNLESS OTHERWISE SPECIFIED, DIMENSIONS ARE INCHES. TOLERANCES ARE:		CUSTOMER:			9500 LUCAS RANCH RD. RANCHO CUCAMONGA, CA. 91730 Phone: (909) 912-0580 Fax: (909) 912-0585
FRACTIONS:	DECIMALS:	ANGLES:	APPROVALS		
DRAWN BY:		Ronnie E.		5/20/2021	
CHECKED:		MG		5/20/2021	
APPROVED:		MG		5/20/2021	
JOB #					
TITLE: 15'-4 5/8"Ø, SQ. BTM, CANT 1, 3/16" THK. w/ 3"Ø DRAIN NOZZLE (SPECIAL)		SIZE: A		PROJECT:	
SCALE:		PART#		REV:	
		1501-019-001		1 OF 1	

THIS DRAWING IS THE EXCLUSIVE PROPERTY OF SUPERIOR TANK COMPANY INC. WHO HOLDS AND MAINTAINS FULL COPYRIGHT PROTECTION UNDER FEDERAL AND STATE LAW. THIS DRAWING CANNOT BE DUPLICATED, PHOTOCOPIED, DIGITALLY TRANSFERRED, OR REPRODUCED WITHOUT THE EXPRESS WRITTEN CONSENT OF SUPERIOR TANK COMPANY INC.

1. GRIND SHARP EDGES DOWN.

NOTES:

DO NOT SCALE DRAWING

EXHIBIT B

INSURANCE REQUIREMENTS

Contractor shall maintain and shall require all of its subcontractors, consultants, and other agents to maintain the insurance listed below. Any requirement for insurance to be maintained after completion of the work shall survive this agreement.

CITY reserves the right to review any and all of the required insurance policies and/or endorsements, but has no obligation to do so. Failure to demand evidence of full compliance with the insurance requirements set forth in this agreement or failure to identify any insurance deficiency shall not relieve Contractor from, nor be construed or deemed a waiver of, its obligation to maintain the required insurance at all times during the performance of this agreement.

A. Workers Compensation & Employers Liability Insurance

- Workers Compensation insurance with statutory limits as required by the Labor Code of the State of California.
- Employers Liability with limits of \$1,000,000 per Accident; \$1,000,000 Disease per employee; \$1,000,000 Disease per policy.
- The policy shall include a written waiver of the insurer's right to subrogate against CITY.
- Required Evidence Of Coverage:
 1. Subrogation waiver endorsement; and
 2. Properly completed Certificate of Insurance.

B. General Liability Insurance

- Commercial General Liability Insurance no less broad than Insurance Services Office (ISO) form CG 00 01.
- Coverage shall be on a standard occurrence form. Claims-Made forms are not acceptable without prior written consent. Modified, limited or restricted Occurrence forms are not acceptable without prior written consent.
- Minimum Limits: \$1,000,000 per Occurrence; \$2,000,000 General Aggregate; \$2,000,000 Products/Completed Operations Aggregate. The

General Aggregate shall apply separately to each project. The required limits may be provided by a combination of General Liability Insurance and Commercial Excess or Umbrella Liability Insurance. If contractor maintains higher limits than the specified minimum limits, CITY requires and shall be entitled to coverage for the higher limits maintained by contractor.

- Any deductible or self-insured retention shall be shown on the Certificate of Insurance. If the deductible or self-insured retention exceeds \$25,000 it must be approved in advance by CITY. Contractor is responsible for any deductible or self-insured retention and shall fund it upon CITY'S written request, regardless of whether Contractor has a claim against the insurance or is named as a party in any action involving CITY.
- Coverage shall be continued for one (1) year after completion of the work.
- CITY shall be endorsed as an additional insured for liability arising out of ongoing and completed operations by or on behalf of the contractor. CITY shall continue to be an additional insured for completed operations for (1) year after completion of the work.
- The policy definition of "insured contract" shall include assumptions of liability arising out of both ongoing operations and the products-completed operations hazard ("f" definition of insured contract in ISO form CG 00 01, or equivalent).
- The insurance provided to the additional insureds shall be primary to, and non-contributory with, any insurance or self-insurance program maintained by them.
- The policy shall cover inter-insured suits and include a "Separation of Insureds" or "severability" clause which treats each insured separately.
- The policy shall be endorsed to include a written waiver of the insurer's right to subrogate against all persons or entities that are, or are required to be, additional insureds.
- The policy shall not contain a Contractors' Warranty or other similar language which eliminates or restricts insurance because of a

subcontractor's failure to carry specific insurance or to supply evidence of such insurance.

- Required Evidence of Coverage:
 1. Copy of the additional insured endorsement or policy language granting additional insured status;
 2. Copy of the endorsement or policy language indicating that coverage applicable to the additional insureds is primary and non-contributory;
 3. Properly completed Certificate of Insurance; and
 4. Completed and signed Agent/Broker Questionnaire with supporting documentation as required.

C. Automobile Liability Insurance

- Minimum Limit: \$1,000,000 combined single limit per accident.
- Coverage shall apply to all owned, hired and non-owned vehicles.
- CITY shall qualify as an insured.
- Required Evidence of Coverage:
 1. Copy of the endorsement or policy language indicating that CITY is an insured; and
 2. Properly completed Certificate of Insurance.

D. Contractors Pollution Liability Insurance

- Minimum Limits: \$1,000,000 per Pollution Incident; \$1,000,000 Aggregate;
- Coverage shall apply to pollution incidents at or from any location at which Contractor is performing work under this agreement.
- Any deductible or self-insured retention shall be shown on the Certificate of Insurance. If the deductible or self-insured retention exceeds \$25,000 it shall be approved in advance by CITY. Contractor is responsible for any deductible or self-insured retention and shall fund it upon CITY written request, regardless of whether Contractor has a claim against the insurance or is named as a party in any action involving CITY.

- CITY shall be endorsed as an additional insured for liability arising out of ongoing and completed operations by or on behalf of the Contractor. Additional insured status shall continue for one (1) year after completion of the work.
- The insurance provided to the additional insureds shall apply on a primary and non-contributory basis with respect to any insurance or self-insurance program maintained by them.
- If the insurance is on a Claims-Made basis, the retroactive date shall be no later than the commencement of work.
- The insurance shall be continued for one (1) year after completion of the work. If the insurance is on a Claims-Made basis, the continuation coverage may be provided by: (a) renewal of the existing policy; (b) an extended reporting period endorsement; or (c) replacement insurance with a retroactive date no later than the commencement of the work.
- Required Evidence of Coverage:
 1. Copy of the additional insured endorsement or policy language granting additional insured status;
 2. Copy of the endorsement or policy language indicating that coverage for the additional insureds is primary and non-contributory;
 3. Properly completed Certificate of Insurance.

E. Surety Bonds

- Bid bond.
- Performance and payment bonds for the entire contract price.
- The surety must be authorized to issue these bonds in the State of California.

F. Standards for Insurance Companies

- Insurers, other than the California State Compensation Insurance Fund, shall have an A.M. Best's rating of at least A:VII.

G. Documentation

- The Certificate of Insurance shall include the following reference:
[]
- The name and address for Additional Insured endorsements and Certificates of Insurance is: City of La Habra
- Contractor shall provide immediate written notice if: (1) any of the required insurance policies is terminated; (2) the limits of any of the required policies are reduced; or (3) the deductible or self-insured retention is increased.
- Current Evidence of Coverage shall be provided for the entire required period of insurance.
- Upon written request, certified copies of required insurance policies shall be provided within thirty (30) days.

Project No. 1-W-23

EXHIBIT C

CERTIFICATES OF INSURANCE AND ENDORSEMENTS

EXHIBIT D
CLAIMS PROCEDURE

SUMMARY OF PUBLIC CONTRACT CODE § 9204

The following procedure will apply to any claims by the Contractor on the City:

A “claim” is a separate demand on the City by a contractor on a public works project and sent by registered mail or certified mail with return receipt requested, for one or more of the following:

- A time extension, including relief from penalties for delay
- Payment by the City of money damages under the terms of the contract
- Payment of an amount that is disputed by the City

Initial Review

The claim must be supported by appropriate documentation. The City has 45 days within which to review the claim and provide the contractor with a written statement identifying the disputed and undisputed portions of the claim. If the City does not issue a written statement, the claim is deemed rejected in its entirety. The City will pay any undisputed portion of the claim within 60 days of issuing the statement.

Meet & Confer

If the contractor disputes the City’s written response, or if the City does not issue one, the contractor may request in writing an informal conference to meet and confer for possible settlement of the claim. The City will schedule the meet and confer conference within 30 days of this request and provide a written statement identifying the remaining disputed and undisputed portions of the claim within 10 business days of the meet and confer. The City will pay the undisputed portion within 60 days of issuing this statement.

Mediation

With respect to any disputed portion remaining after the meet and confer, the City and contractor will submit the matter to nonbinding mediation, agree to a mediator within 10 business days after issuing the written statement, and share mediation costs equally. If mediation is unsuccessful, then the terms of the public works agreement and applicable law will govern resolution of the dispute.

Miscellaneous Provisions

Amounts not paid by the City in a timely manner bear interest at 7% per annum. Subcontractors may submit claims via this procedure through the general contractor. The City and contractor may waive the requirement to mediate, but cannot otherwise waive these claim procedures.