

DRAFT ORDINANCE NO.

AN ORDINANCE OF THE CITY COUNCIL OF THE CITY OF LA HABRA, CALIFORNIA, MAKING THE REQUIRED FINDINGS AND APPROVING PLANNED UNIT DEVELOPMENT PRECISE PLAN 22-02 FOR THE CONSTRUCTION OF A 3,875 SQUARE FOOT, DUAL TENANT BUILDING AT 711 EAST IMPERIAL HIGHWAY, AS PER THE APPROVED PLANS AND SUBJECT TO CONDITIONS, AND MAKING A DETERMINATION THAT THE REQUEST IS CATEGORICALLY EXEMPT FROM THE CALIFORNIA ENVIRONMENTAL QUALITY ACT PURSUANT TO SECTION 15303, CLASS 3: "NEW CONSTRUCTION OR CONVERSION OF SMALL STRUCTURES" AND SECTION 15061(B)(2) OF THE CALIFORNIA ENVIRONMENTAL QUALITY ACT GUIDELINES

THE CITY COUNCIL OF THE CITY OF LA HABRA, CALIFORNIA HEREBY FINDS AND DECLARES AS FOLLOWS:

WHEREAS, on November 9, 2022, the Applicant, Paraj Patel, filed an application requesting approval of Planned Unit Development Precise Plan 22-02 to construct a 3,875 square foot, dual tenant commercial building at 711 East Imperial Highway (the "Project"); and

WHEREAS, the Applicant concurrently submitted Conditional Use Permit 22-31 to operate a drive-through restaurant (dba: Dunkin' Donuts) within one of the tenant spaces of the proposed commercial building at the subject site; and

WHEREAS, on September 24, 2018, the Planning Commission approved resolutions recommending City Council approval of Mitigated Negative Declaration 17-02 (the "MND"), Planned Unit Development Master Plan No.17-01 (the "Master Plan") and a Development Agreement between the City of La Habra and Greg S. Jones Revocable Trust and Sunny Investments, LLC (the "Development Agreement") for the development of the properties at 701-751 E. Imperial Highway. The Planning Commission also approved Tentative Parcel Map No. 2017-154 to divide the property into four parcels; and Conditional Use Permits (CUPs) to allow the operation of a hotel with alcohol sales on Parcel 1 and drive-through restaurants on Parcels 2 and 3 with Parcel 4 vacant, but to be developed in the future with a permitted use; and

WHEREAS, on December 3, 2018, the City Council approved the MND; and subsequently on December 18, 2018 adopted ordinances approving the Master Plan and Development Agreement; and

WHEREAS, pursuant to Section 18.52.110 (Conformance) of Chapter 18.52 (PUD Planned Unit Development Overlay Zone) of the La Habra Municipal Code, after the adoption of a planned unit development ordinance, and prior to the issuance of any building permit, a final development plan is required to be prepared and final subdivision

map or parcel map recorded, if either is involved. The final development plan shall conform to the ordinance adopting the planned unit development and shall show to scale all buildings, off-street parking facilities, landscaping, finished grades and such other details as will suffice to indicate conformance with all the features, conditions and characteristics upon which the approval was predicated. Development of the hotel (dba: La Quinta Inn and Suites) on Parcel 1 is underway and a drive-through restaurant (dba: Taco Bell) has been constructed and is in operation on Parcel 3. The plans that were approved by Planning Commission in conjunction with the CUP for the hotel and the Taco Bell met the requirements for a final development plan, as required by Section 18.52.110; and

WHEREAS, the Final Map for the Tentative Parcel Map was approved by City Council on April 6, 2020 and recorded on May 14, 2020. All on-site utilities have been installed, the required drive aisles have been constructed, and the required intersection improvements were completed as per the Master Plan; and

WHEREAS, on April 25, 2022, the Planning Commission recommended approval of a Precise Plan on Parcel 4 for the development of 6,250 square foot commercial building (dba: Hallmark), which was subsequently approved by City Council by adoption of Ordinance No. 1842 on June 6, 2022; and

WHEREAS, Popeye's Louisiana Kitchen chose not to move forward with development of a drive-through restaurant on Subject Site (Parcel 2), and subsequent recitals indicated that a CUP was thus required for a new restaurant on the site; and

WHEREAS, the Applicant is now requesting to develop the subject site with a new two-tenant commercial building and allow the operation of a new drive-through restaurant (dba: Dunkin' Donuts) within one of the tenant spaces. As a result, the proposed project requires approval of a new Precise Plan and CUP; and

WHEREAS, it has been determined that the Development Agreement and Master Plan that apply to the subject site and the other parcels on the property do not need to be amended to accommodate the proposed Project in that the proposed use is in substantial conformance with the uses contemplated by the Master Plan pursuant to LHMC Section 18.52.130 (Re-approval required) and Recital D and Standard Condition No. 1.6 of the Development Agreement; and

WHEREAS, staff has determined that the proposed project is Categorically Exempt from CEQA pursuant to CEQA Guidelines Section 15303, Class 3 "New Construction or Conversion of Small Structures." This exemption class consists of the construction and location of limited numbers of new, small facilities or structures, including commercial uses not exceeding 10,000 square feet in floor area on sites zoned for such use if not involving the use of significant amounts of hazardous substances where all necessary public services and facilities are available and the surrounding area is not sensitive. As further described in the staff report, the proposed two-unit commercial building would be 3,875 square feet. In addition, the Project is proposed on a parcel that

was part of Planned Unit Development Master Plan 17-01. The proposed Project does not meet any of the exceptions described in Section 15300.2 of the CEQA Guidelines. The location of the Project is predominantly urban and not considered a sensitive environment; therefore, the Project will not result in any significant impacts that may otherwise occur in a sensitive environmental area. The cumulative impact of this Project, and the approval of other projects like it in the vicinity, is not expected to have any significant environmental impact. The Project is not located along any state designated scenic highway nor within any designated hazardous waste site. Staff does not expect any significant impacts or unusual circumstances related to the approval and construction of this Project. Therefore, pursuant to the provision under Section 15061(B)(2) of the California Environmental Quality Act Guidelines, the Project is categorically exempt from CEQA; and

WHEREAS, on August 28, 2023, the Planning Commission held a duly noticed public hearing to consider the Applicant's request for Planned Unit Development Precise Plan 22-02, at which time it considered all material and evidence, whether written or oral, and the procedures and standards required by the La Habra Municipal Code. The Planning Commission adopted Resolution No. 23-10, recommending that the City Council adopt an ordinance approving Planned Unit Development Precise Plan 22-02 by a 5-0 vote. The Planning Commission concurrently considered and approved Conditional Use Permit 22-31 to allow the operation of a drive-through restaurant (Dunkin' Donuts) within one of the tenant spaces at 711 East Imperial Highway, contingent upon the City Council's approval of Planned Unit Development Precise Plan 22-02; and

WHEREAS, on October 2, 2023, the City Council held a duly noticed public hearing to consider the proposed Project, at which time it considered all material and evidence presented, whether written or oral, including the Planning Commission's recommendation; and

WHEREAS, all legal requirements prior to the adoption of this Ordinance have occurred.

NOW, THEREFORE, THE CITY COUNCIL OF THE CITY OF LA HABRA, CALIFORNIA DOES ORDAIN AS FOLLOWS:

SECTION 1. Planned Unit Development Precise Plan 22-02. The City Council finds and determines that the Applicant has succeeded in meeting its burden of providing evidence to support the granting of and approves Planned Unit Development Precise Plan 22-02 based on the following findings required by Section 18.38.100 of the La Habra Municipal Code and subject to the conditions attached hereto as **Exhibit A**.

- 1. The location, design and proposed uses are compatible with the character of existing development in the vicinity.**

The subject site is located within a commercial industrial district, and is surrounded by industrial and commercial buildings, restaurants, and medical office uses. The

project site is one of four parcels of an approved Master Plan that included two drive-through restaurants, one of which was approved on the subject site, as a hotel, and a retail store. The proposed project is fairly similar to the previously approved project on the site and the proposal is to use exterior materials and colors that complement the other buildings that are a part of Master Plan. Additionally, the closest residential properties are situated south across the six-lane Imperial Highway, which are surrounded by 14-foot-tall masonry sound walls and are over 130 feet away. Therefore, the use is not expected to create any impacts to any adjacent residential properties, and the design of the proposed building would be compatible with the surrounding commercial and industrial uses.

2. The plan for development will produce internally an environment of stable and desirable character, and not tend to cause any traffic congestion on surrounding or access streets.

A Traffic Circulation and Queuing Assessment was conducted on the proposed project, which determined that the project would result in an addition of less than 40 pm peak hour trips when compared to the previously approved project. Per the City of La Habra Traffic-Impact Analysis Guidelines for Vehicles Miles Traveled and Level of Service Assessment, dated August 2021, the project did not necessitate a traffic study. It also determined that the surrounding streets were adequate to support the proposed uses and the other uses on the site. A queuing analysis was also prepared which shows that the drive-through lane, designed to hold up to 12 vehicles, has more than sufficient space to accommodate the maximum peak demand of nine vehicles, as well as three additional vehicles, without encroaching into the drive aisle or impacting traffic circulation on the site. Additionally, the proposed project would provide the amount of parking required by the LHMC. Therefore, the plan for development will produce internally an environment of stable and desirable character.

3. The standards of development applicable to the planned unit development project as shown on the precise plan are subject to one of the following or any combination thereof:

- a. All of the development standards of the appropriate zone which would permit the requested land use,
- b. Such standards of development which are clearly designated in the approved master plan.

The Master Plan refers back to the development standards of the PC-I Zone, where the project site is located. The proposed dual-unit commercial building meets all of the development standards of the PC-I Zone and the proposed future retail use is a permitted use within the PC-I Zone. Furthermore, the LHMC permits the proposed drive-through restaurant within the PC-I Zone, subject to the approval

of a CUP. The Planning Commission approved the CUP for the project, contingent upon approval of the Planned Unit Development Precise Plan.

4. The proposed development will be well integrated into its setting.

The tenants of the proposed dual-unit commercial building will consist of a future retail tenant and drive-through restaurant, and would be compatible with other uses within the same Master Plan. The proposed building will include colors and materials such as the use of gray stucco and brown siding which are used on the other buildings on the site to help ensure a cohesive design. Additionally, the layout and orientation of the building as well as the drive-through lane are the same as the adjacent drive-through restaurant (Taco Bell) to the east of the site. As such, the Master Plan will also maintain a cohesive streetscape design. The proposed building pad is designed around the existing drive aisle, driveways, and signalized driveway to ensure that there is no impact to the site circulation and layout. Therefore, the proposed project will be well integrated into its setting.

5. Provision is made for both public and private open spaces, at least equivalent to that required by the underlying preceding zoning regulations.

Over 21% of the Subject Site will be landscaped, which will enhance the experience of the customers of the businesses on the site and pedestrians and vehicles that travel along East Imperial Highway. Pursuant to the Development Agreement, the original applicant contributed \$130,000.00 in fees towards the construction of a public bicycle path, and dedicated a 10-foot wide area along the east property line, to be used as a segment of a path connecting the La Habra Union Pacific Bikeway Path to the Juanita Cook Greenbelt path in the City of Fullerton, as required by the City's Master Bikeway Plan.

6. Suitable provision is made, where appropriate, for the protection and maintenance of private areas reserved for common use.

The businesses will be publicly accessible to La Habra residents and visitors via the two driveways along East Imperial Highway and the circulation on site. Although the proposed project meets the LHMC requirements for parking, there is a reciprocal parking and access agreement between the properties that are subject to the Master Plan. Additionally, over 21% of the subject site will be landscaped, which will be maintained by the property owner. This landscaping will enhance the experience of the customers of the businesses on site, as well as travelers along East Imperial Highway.

7. The proposed development does not negatively impact the City's ability to provide services over the short and long term to City residents because the projected cost of providing City services to the property outweighs the economic benefits of the project to the city.

All required in-ground infrastructure, necessary utilities, drive aisles, roads and traffic signals have already been installed, as required by the Master Plan. Additionally, several documents were prepared in analyzing the impacts as well as the benefits of the Master Plan, which determined that the existing water and sewer service were adequate to serve the project. The proposal was taken into consideration under the Traffic Assessment, which determined that the inclusion of a new retail space did not trigger a higher traffic demand to necessitate a new Traffic Study. It also determined that the surrounding streets were adequate to support the proposed uses and the other uses on the site. Therefore, it is not anticipated that approval of the subject Precise Plan will negatively impact the City's ability to provide services to City residents.

8. There is substantial compliance with the spirit and intent of this code.

The proposed project complies with all the applicable development standards of the PC-I Zone. The layout and orientation of the new two-tenant commercial building is similar to the previously approved project, and would include a drive-through restaurant use, which was previously approved for the subject site.

9. That the phasing of development under the Master Plan as provided for by the proposed Precise Plan, if any, is appropriate.

A phasing plan was not provided for the proposed project. The surrounding parcels are currently being developed with a La Quinta Inn & Suites and Hallmark retail store and already occupied by a Taco Bell drive-through restaurant. The majority of the development approved by the Master Plan is already underway; all required in-ground infrastructure has been installed, including all necessary utilities, drive aisles, roads and traffic signals. Therefore, the subject site is ready to accommodate the construction of the proposed commercial building. It is anticipated that the proposed project will be completed within the six-year timeline approved for the Development Agreement and Master Plan, which would require development of the subject site by no later than January 16, 2025. The Applicant has indicated that they will begin construction of the project immediately upon completion of the entitlement and permitting process.

10. The proposed project complies with all appropriate requirements of the California Environmental Quality Act.

Staff has determined that the proposed project is Categorical Exempt from CEQA pursuant to CEQA Guidelines Section 15303, Class 3 "New Construction or Conversion of Small Structures." This exemption class consists of the construction and location of limited numbers of new, small facilities or structures, including commercial uses not exceeding 10,000 square feet in floor area on sites zoned for such use if not involving the use of significant amounts of hazardous substances where all necessary public services and facilities are available and the surrounding area is not sensitive. As further described in the staff report, the proposed two-unit

commercial building would be 3,875 square feet. In addition, the project is proposed on a parcel that was part of Planned Unit Development Master Plan 17-01. The infrastructure required for the implementation of this Master Plan has been constructed. A drive-through restaurant does not involve the use of hazardous substances, all necessary public services and facilities are available and the surrounding area is not environmentally sensitive. The Project is not subject to any of the exceptions for exemption under Section 15300.2 of the CEQA Guidelines. The location of the Project is predominantly urban and not considered a sensitive environment; therefore, the Project will not result in any significant impacts that may otherwise occur in a sensitive environmental area. The cumulative impact of this Project, and the approval of other projects like it in the vicinity, is not expected to have any significant environmental impact. The Project is not located along any state designated scenic highway nor within any designated hazardous waste site. Staff does not expect any significant impacts or unusual circumstances related to the approval and construction of this Project. Therefore, the Project is categorically exempt from CEQA, pursuant to the provision under Section 15061(B)(2) of the California Environmental Quality Act Guidelines.

SECTION 2. Environmental Compliance. The City Council finds and determines that the Project is Categorically Exempt from CEQA pursuant to CEQA Guidelines Section 15303, Class 3 “New Construction or Conversion of Small Structures.” This exemption class consists of the construction and location of limited numbers of new, small facilities or structures, including commercial uses not exceeding 10,000 square feet in floor area on sites zoned for such use if not involving the use of significant amounts of hazardous substances where all necessary public services and facilities are available and the surrounding area is not sensitive. As further described in the staff report, the proposed two-unit commercial building would be 3,875 square feet. In addition, the Project is proposed on a parcel that was part of Planned Unit Development Master Plan 17-01. The infrastructure required for the implementation of this Master Plan has been constructed. The proposed Project does not meet any of the exceptions described in Section 15300.2 of the CEQA Guidelines. The location of the Project is predominantly urban and not considered a sensitive environment; therefore, the Project will not result in any significant impacts that may otherwise occur in a sensitive environmental area. The cumulative impact of this Project, and the approval of other projects like it in the vicinity, is not expected to have any significant environmental impact. The Project is not located along any state designated scenic highway nor within any designated hazardous waste site. Staff does not expect any significant impacts or unusual circumstances related to the approval and construction of this Project. Therefore, pursuant to the provision under Section 15061(B)(2) of the California Environmental Quality Act Guidelines, the Project is categorically exempt from CEQA.

SECTION 3. Severability. If any section, subsection, sentence, clause, phrase or portion of this Ordinance is for any reason held to be invalid or unconstitutional by the decision of any court of competent jurisdiction, such decision shall not affect the validity of the remaining portions of this Ordinance. The City Council of the City of La Habra declares that it would have adopted this Ordinance and each section, subsection,

sentence, clause, phrase, or portion thereof, irrespective of the fact that any one or more sections, subsections, sentences, clauses, phrases or portions be declared invalid or unconstitutional.

SECTION 4. Effective Date. This Ordinance shall take effect thirty (30) days after its final passage.

SECTION 5. Certification. The City Clerk shall certify to the passage and adoption of this Ordinance and shall cause the same to be published or posted in the manner required by law.

PASSED, APPROVED, AND ADOPTED this _____ day of October, 2023.

James Gomez, Mayor

ATTEST:

Rhonda J. Barone, CMC
City Clerk

STATE OF CALIFORNIA }
COUNTY OF ORANGE } SS.
CITY OF LA HABRA }

I, Rhonda J. Barone, CMC, City Clerk of the City of La Habra, do hereby certify that the above and foregoing is a true and correct copy of Ordinance No. _____ introduced at a regular meeting of the City Council of the City of La Habra held on the ____ day of October, 2023, and was thereafter adopted at a regular meeting held on the ____ day of October, 2023, by the following vote:

AYES: COUNCILMEMBERS:
NOES: COUNCILMEMBERS:
ABSENT: COUNCILMEMBERS:
ABSTAIN: COUNCILMEMBERS:

Said ordinance has been published or posted pursuant to law.

Witness my hand and the official seal of the City of La Habra this ____ day of _____, 2023.

Rhonda J. Barone, CMC
City Clerk

EXHIBIT A

PLANNED UNIT DEVELOPMENT PRECISE PLAN 22-02 CONDITIONS OF APPROVAL

General conditions:

Standard Condition 1.1 CODE COMPLIANCE

The applicant/developer shall comply with the City of La Habra Municipal Code and all applicable ordinances.

Standard Condition 1.2 BUILDING PERMITS

The applicant/developer shall comply with all applicable California/La Habra Building Code requirements and obtain all required permits from the Building Official. Construction shall comply with the California/La Habra Building Code (or Residential Code), California/La Habra Plumbing Code, California/La Habra Mechanical Code, California/La Habra Electrical Code, California/La Habra Energy Code, and California/La Habra Green Building Standards Code, as applicable.

Standard Condition 1.3 GRAFFITI ABATEMENT

The applicant/developer shall maintain the property in a clean and orderly condition at all times and remove any graffiti from the site within forty-eight (48) hours of its discovery in matching colors to the existing improvements.

Standard Condition 1.4 LA COUNTY FIRE DEPARTMENT

The applicant/developer shall comply with the Los Angeles County/La Habra Fire Code and Fire Department requirements, as applicable.

Standard Condition 1.5 MINOR MODIFICATIONS

The Director of Community and Economic Development or designee may approve minor modifications through the Administrative Adjustment process to the conditions of approval and the project plans so long as the intent of the Planning Commission or City Council is maintained.

Standard Condition 1.6 PLANS

This approval is for those plans included as Exhibit B to this Ordinance. The project shall be developed and maintained in substantial conformance with said plans, except as otherwise specified in these conditions of approval.

Standard Condition 1.8 VIOLATION

In the event that the applicant/developer violates or fails to comply with any of the conditions of approval of this permit, the City may take measures to cure such violations, including but not limited to, administrative citation and full reimbursement of the City for its costs and expenses, including but not limited to, attorney's fees, in undertaking such corrective action. Reimbursement of enforcement costs shall constitute a civil debt and may be collected by any means permitted by law. In the event that violations of this permit occur, the City shall refrain from issuing further permits, licenses or other approvals until such violations have been fully remedied.

Standard Condition 1.9 LANDSCAPE MAINTENANCE

The applicant/developer shall maintain landscaping in a healthy and well-kept manner at all times. Dead or damaged landscape material/vegetation shall be replaced immediately per the approved landscape plan. The irrigation system shall be maintained at all times. Trees shall be permitted to grow to their maximum height.

Standard Condition 1.10 BUILDING REPAINTING

The applicant/developer shall maintain the building in good condition at all times and shall repaint the approved building and accouterments every eight (8) years at a minimum, starting from the date of a permit final for the project. The Director of Community and Economic Development or designee may require more frequent painting if the improvements are not maintained in good condition.

Standard Condition 1.11 PAVEMENT RESURFACING

The applicant/developer shall re-slurry and re-stripe the parking areas every five (5) years at a minimum starting from the date of a permit final for the project. The Director of Community and Economic Development or designee may require more frequent slurry and re-striping if the parking areas are not maintained in good condition.

Standard Condition 1.12 SIGN MAINTENANCE

The applicant/developer shall maintain the signs in good condition at all times and shall repaint the freestanding signs that are proposed to advertise the business every eight (8) years at a minimum starting from the date of a permit final for the project. The Director of Community and Economic Development may require more frequent painting if the improvements are not maintained in good condition.

Standard Condition 1.30 TRAFFIC CONTROL MEASURES (Modified)

The applicant/developer shall provide a traffic control measure plan or documentation to ensure that traffic impacts are minimized on any adjacent public street, to the satisfaction of the Director of Public Works. Failure by the applicant/developer to maintain adequate traffic control measures whereby the City of La Habra has to provide traffic control shall result in all costs being borne by the applicant/developer as determined by the Chief of Police and the Director of Public Works.

Standard Condition 1.38 CANOPIES AND AWNINGS

The applicant/developer shall maintain canopies and awnings in good condition at all times and shall replace them every five (5) years at a minimum. The Director of Community Development may require more frequent replacement if the canopies are not maintained in good condition or become damaged, faded, ripped, frayed, or marred by graffiti. Canopies and awnings shall not display any signage.

Standard Condition 1.41 INDEMNIFICATION

To the maximum extent permitted by law, the applicant and any successor in interest shall defend, indemnify and hold harmless the City of La Habra and its elected and appointed officials, officers, agents and employees from and against any and all actions, claims, damages, liabilities and/or proceedings (collectively referred to as "action") arising out of or in any way relating to the applicant's project or any approvals granted by the City related to the applicant's project, including, but not limited to, any action to attack, challenge, set aside, void, or otherwise modify or annul the approval of any entitlement or permit relating to the project or the environmental review of any entitlement relating to the project. The indemnification and hold harmless shall include, but not be limited to, any and all costs incurred by the City in defense of any action arising out of or relating to the applicant's project or any approvals granted by the City related to the applicant's project, including, but not limited to, payment of all court costs and attorneys' fees, costs of any judgements or awards against the City (including any award of attorneys' fees), damages, and/or settlement costs. The City shall have the right to choose its own legal counsel to represent the City's interests, and applicant shall indemnify City for such costs incurred by the City.

Prior to the issuance of preliminary or precise grading permits:

Standard Condition 3.5 DESIGN OF DRAINAGE FACILITIES

The applicant/developer shall design all drainage facilities in such a manner as to imitate the manner in which storm water is presently crossing said property line or a drainage acceptance letter shall be obtained from the downstream property owner to the satisfaction of the Building Official and City Engineer.

Standard Condition 3.8 PLANS SUBMITTAL

The applicant/developer shall provide street improvement plans prepared on standard size sheets by a licensed Civil Engineer and be submitted for approval by the City Engineer. Standard plan check and inspection fees shall be paid by the applicant.

Standard Condition 3.9 UTILITY PLANS

The applicant/developer shall provide all utility plans to be reviewed and approved by the Director of Community and Economic Development or designee and the City Engineer.

Standard Condition 3.11 GRADING

The applicant/developer shall grade the subject property in accordance with the Grading Ordinance and to the satisfaction of the Building Official. A grading plan shall be submitted by the applicant/developer for review and approval. Grading shall be in substantial conformance to the project plans approved by the Planning Commission. Grading permit security shall be posted to the satisfaction of the Building Official and the City Attorney guaranteeing completion of grading in accordance with the project plans.

Prior to the issuance of building permits:

Standard Condition 4.1 CONDITIONS ON CONSTRUCTION PLANS

The applicant/developer shall include these conditions of approval on the construction plans.

Standard Condition 4.3 FINAL PRIORITY PROJECT WATER QUALITY
MANAGEMENT PLAN

The applicant/developer shall submit a Final Priority Project WQMP to the City for review and approval by the City Engineer or designee. This plan shall be in conformance with all current NPDES requirements.

Standard Condition 4.8 WATER SUPPLY AND SEWER FACILITIES

The applicant/developer shall ensure that the water supply facilities and sewer facilities be designed and constructed to the specifications of the City of La Habra and the Public Works Director with all incidental fees and costs paid by the applicant. The sewer and water facility will be maintained by the applicant/developer.

Standard Condition 4.10 SITE LIGHTING PLAN

The applicant/developer shall submit a site lighting plan in conformance with City standards for review and approval by the Building Official and the Director of Community and Economic Development or designee prior to the issuance of building permits. The plan shall ensure that all exterior lighting (i.e., parking areas, building areas, and entries)

shall employ illumination in a manner that meets the approval of the Building Official and the Director of Community and Economic Development or designee before building permits are issued. All light fixtures shall be designed and located in a manner that does not allow spill-over onto adjacent properties.

Standard Condition 4.12 TRAFFIC STRIPING AND SIGNING PLAN

The applicant/developer shall provide an on-site and off-site traffic striping and traffic signing plan to the satisfaction of the City Engineer. All plans shall be approved prior to the issuance of a building permit.

Standard Condition 4.15 SERVICE TRUCK ACCESS

The applicant/developer shall provide access for service trucks across prepared surfaces suitable for continuous heavy truck usage, as determined by the City Engineer.

Standard Condition 4.17 UNDERGROUND UTILITIES

The applicant/developer shall provide a plan to the City Engineer showing that all onsite utilities within the project to be installed underground in accordance with current utility practices. All onsite utilities shall be installed prior to building permit issuance and before any onsite paving. All existing aerial utilities shall be removed and/or placed underground including street light wires and other overhead wires. The City Engineer shall have the right to comment, modify, approve or disapprove the utility plan for each utility.

Standard Condition 4.18 WATER AND/OR SEWER SERVICE

The applicant/developer shall submit development plans for the property to the Public Works Department so that the Utility Authority can establish the Terms and Conditions for Water and/or Sewer Service. The sewer and water facility will be maintained by the applicant/developer.

Standard Condition 4.22 LANDSCAPE PLANS

The applicant/developer shall submit for review and approval detailed landscape and irrigation plans prepared by a licensed landscape architect to the Director of Community and Economic Development or designee and the Director of Public Works. The plans shall comply with the Model Water Efficient Landscape Ordinance and shall include the use of a separate connection, backflow preventer and connection for future reclaimed water service. At a minimum, tree size shall be 24-inch box and shrubs shall be 5-gallon size.

Standard Condition 4.25 TRASH ENCLOSURE

The applicant/developer shall provide plans for review by the City Engineer to install an enclosed, six-foot tall masonry block trash enclosure with enough area to contain a three-

yard refuse bin and a ninety-six gallon recycling cart, finished to match the main building. Said trash enclosure shall include provisions for a solid roof cover, hose bib, and an area drain connected to the sanitary sewer system. The design and location is subject to approval by the City Engineer and Director of Community and Economic Development or designee.

Standard Condition 4.26 SEPARATE FIRE LINE CONNECTION

The applicant/developer shall provide plans for review by the City Engineer to install a separate fire-line connection with backflow assembly to service the on-site fire protection sprinkler system and submit a fire flow test from an independent company to ensure proper size of the fire line, to the satisfaction of the Public Works Director.

Standard Condition 4.27 PRE-CONSTRUCTION MEETING

The applicant/developer shall have a pre-construction meeting with City staff prior to any construction activity occurring, to the satisfaction of the Director of Community and Economic Development.

Standard Condition 4.33 TRAFFIC IMPROVEMENT FEES (MODIFIED)

The applicant/developer shall pay all fees related to the requirements of the Citywide Traffic Improvement Fee. The fee has been determined to be \$13,952 based on the Traffic Study for the Proposed Dunkin' Donuts Project in the City of La Habra, prepared by Linscott Law & Greenspan Engineers, dated July 17, 2023.

Standard Condition 5.17 UP LIGHTING

The applicant/developer shall provide up lighting on all trees within the front landscape area prior to the issuance of a Certificate of Occupancy to the satisfaction of the Director of Community and Economic Development and City Engineer.

Standard Condition 5.18 PUBLIC ART

The applicant/developer shall design and install artwork in a public place on or in the vicinity of the project site, as approved by the Community Services Commission prior to issuance of a Certificate of Occupancy. The cost or value of such work shall equal or exceed one percent (1%) of the project cost, as determined by the Chief Building Official. In-lieu of acquiring and installing artwork, the applicant may contribute an amount equal to one percent (1%) of the project cost to the Public Arts Fund prior to the issuance of building permits.

Prior to authorization to use, occupy, and/or operate:

Standard Condition 4.28 EXTERIOR STREET IMPROVEMENTS

The applicant/developer shall construct all exterior street improvements to the satisfaction of the City Engineer prior to the issuance of a Certificate of Occupancy.

Standard Condition 5.3 INSTALLATION OF TRAFFIC STRIPING AND
SIGNING (Modified)

The applicant/developer shall install all required onsite traffic striping and signing to the satisfaction of the City Engineer and Traffic Manager.

Standard Condition 5.7 LANDSCAPE INSTALLATION

The applicant/developer shall install all required landscaping and irrigation systems as per the approved plans to the satisfaction of the Director of Community and Economic Development or designee. Upon final inspection, staff will verify quantity, size, placement, and health of all plant material, at which time staff may require replacement or addition of landscaping material to ensure a high quality planting.

Standard Condition 5.10 FINAL WATER QUALITY MANAGEMENT PLAN –
(WQMP) - BEST MANAGEMENT PRACTICES
(BMPs)

The applicant/developer shall demonstrate the following related to the WQMP to the satisfaction of the City Engineer or designee:

- a. All structural BMPs described in the Priority Project WQMP have been constructed and installed in conformance with approved plans and specifications.
- b. The applicant is prepared to implement all non-structural BMPs described in the WQMP.
- c. An adequate number of copies of the approved WQMP are available on-site and for the future occupants.
- d. A mechanism or agreement acceptable to the City has been executed for the long term funding and performance of BMP operations, maintenance, repair, and/or replacement.

Standard Condition 5.13 CATCH BASIN MARKING

The applicant/developer shall mark all catch basins and public access points that cross or abut an open channel with a water quality message in accordance with City Standards to the satisfaction of the City Engineer.

Standard Condition 5.15 BICYCLE FACILITIES

The applicant/developer shall install and maintain an artistic bicycle rack on-site in a convenient location prior to issuance of Certificate of Occupancy, to the satisfaction of the Director of Community and Economic Development.

Project Specific Conditions:

1. The Applicant/developer shall submit designs, process all paperwork and ensure that all on-site and adjacent utility boxes, transformers and/or traffic control cabinets located along Imperial Highway, within the public right of way, are aesthetically enhanced (i.e. painted by an artist or wrapping with image consistent with the landscaping) as permitted by and abiding to the required standards of the utility company, to the satisfaction of the Director of Community and Economic Development prior to a Certificate of Occupancy.
2. The Applicant/developer shall include an energy efficient landscape design plan that reduces exterior heat gains and heat island effects through the installation of trees, reflective paving materials, and cool roofs to reduce energy demand within the project. The plan shall be submitted for review and approval by the Director of Community and Economic Development prior to the issuance of Building Permits.
3. The Applicant/developer shall use and maintain a common design theme for the subject property for all structures to include similar colors, exterior building finish materials, and on-site amenities to include parking lot lights, trash receptacles, and benches, to the satisfaction of the Director of Community and Economic Development or designee.
4. The Applicant/developer shall obtain approval from the County of Los Angeles Fire Department, Fire Prevention Engineering Section Building Plan Check Unit prior to building permit issuance. The Applicant can contact the Fire Prevention Engineering Unit at (323) 890-4132 for additional Fire Department requirements and EPIC-LA submittal instructions.
5. The Applicant/developer shall have all roof top equipment screened from public view from all building elevations. Screening materials shall be architecturally consistent with the design of the building. Design plans identifying the roof screening shall be submitted and approved by the Director of Community and Economic Development prior to the issuance of building permits.
6. The Applicant/developer shall pay all fees related to requirement of the Traffic Impact Analysis review. The fee has been determined to be \$2,755 and shall be paid prior to the issuance of a building permit.

EXHIBIT B
PROJECT PLANS

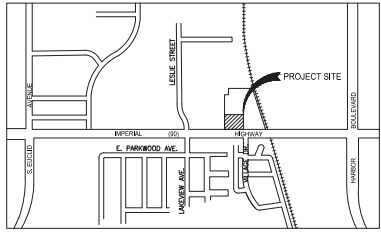

VICINITY MAP
N.T.S.



LEGEND

- PROPERTY LINE
- - - CIVIL LIMITS OF WORK
- - - EASEMENT
- - - SETBACK
- SIGN POST
- ACCESSIBLE ROUTE (LOCATION PURPOSES ONLY, DO NOT PAINT)
- STANDARD DUTY CONCRETE SIDEWALK
- HEAVY DUTY CONCRETE PAVEMENT
- PROPOSED LANDSCAPE AREA
- DETECTABLE WARNINGS
- STANDARD DUTY ASPHALT PAVEMENT
- X PARKING STALLS

PARKING DATA	
STANDARD SPACE	= 21
ACCESSIBLE SPACE	= 2
TOTAL SPACES PROVIDED	= 23 SPACES

SITE PLAN NOTES

- 1 PROPOSED CONCRETE CURB.
- 2 PROPOSED STANDARD DUTY CONCRETE SIDEWALK.
- 3 PROPOSED STANDARD DUTY ASPHALT.
- 4 PROPOSED HEAVY DUTY CONCRETE PAVEMENT
- 5 PROPOSED RIBBON GUTTER.
- 6 PROPOSED LANDSCAPE.
- 7 PROPOSED CURB RAMP WITH DETECTABLE WARNINGS.
- 8 PROPOSED STANDARD 90° PARKING STALL.
- 9 PROPOSED ACCESSIBLE 90° PARKING STALL.
- 10 PROPOSED BUILDING FOOTPRINT.
- 11 ACCESSIBLE PARKING SIGN.
- 12 ACCESSIBLE PATH OF TRAVEL SIGN.
- 13 PROPOSED MONUMENT SIGN.
- 14 PROPOSED DRIVE-THRU WINDOW.
- 15 PROPOSED MENU BOARD.
- 16 PROPOSED DRIVE-THRU SPEAKER POST.
- 17 PROPOSED GREASE INTERCEPTOR.
- 18 PROPOSED CLEARANCE BAR.
- 19 PROPOSED DRIVE-THRU DIRECTIONAL SIGN.
- 20 PROPOSED "CURBSIDE PICKUP" PARKING STALL PAVEMENT MARKING.
- 21 PROPOSED DRIVE-THRU PAVEMENT MARKING.
- 22 PROPOSED GUARDRAIL.
- 23 PROTECT-IN-PLACE EXISTING CURB RAMP AND DETECTABLE WARNINGS.
- 24 PROTECT-IN-PLACE EXISTING CONCRETE CURB AND GUTTER.
- 25 PROTECT-IN-PLACE EXISTING TRANSFORMER.
- 26 PROTECT-IN-PLACE EXISTING DRIVEWAY.
- 27 PROTECT-IN-PLACE EXISTING SIDEWALK.
- 28 PROTECT-IN-PLACE EXISTING PAVEMENT.
- 29 PROTECT-IN-PLACE EXISTING RETAINING WALL.
- 30 PROTECT-IN-PLACE EXISTING RIP RAP.
- 31 PROTECT-IN-PLACE EXISTING STREET LIGHT, PER SEPARATE PLAN.
- 32 PROTECT-IN-PLACE EXISTING STORM DRAIN INLET.

SITE DATA

LOT SIZE:	±38,542 S.F. (0.88 AC)
LIMITS OF DISTURBANCE:	±20,502 S.F. (±0.47 AC)
PROPOSED IMPERVIOUS AREA:	±11,710 S.F.
PROPOSED PERVIOUS AREA:	±8,290 S.F.
EXISTING USE:	VACANT
PROPOSED USE:	MULTI-TENANT BUILDING
BUILDING SIZE:	3,875 S.F.
DUNKIN' DONUTS:	1,880 S.F.
RETAIL UNIT:	1,995 S.F.

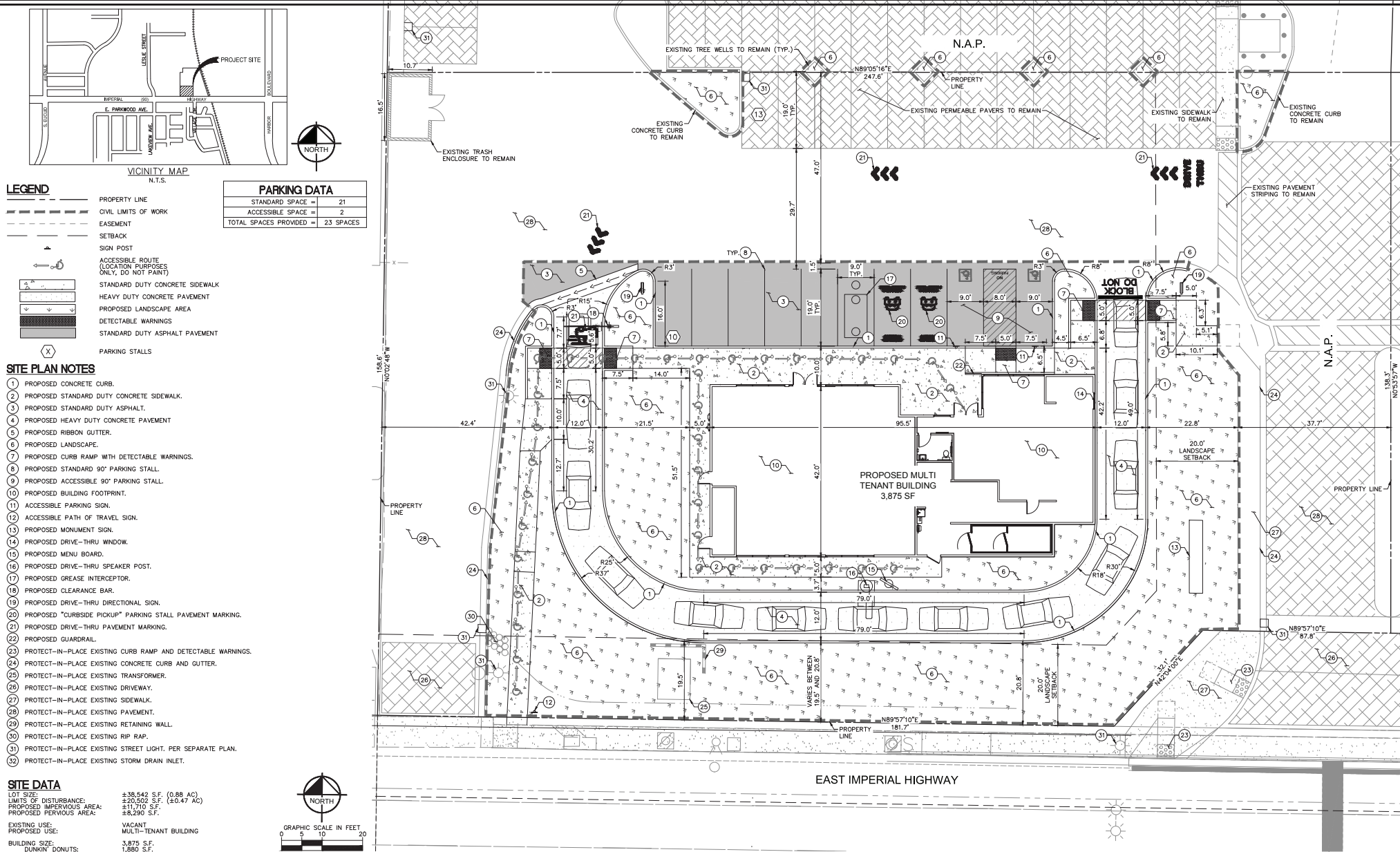
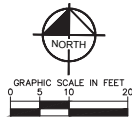

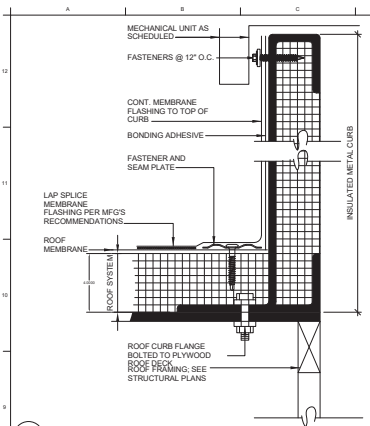

1 ROOF - CURB DETAIL
3" = 1'-0"

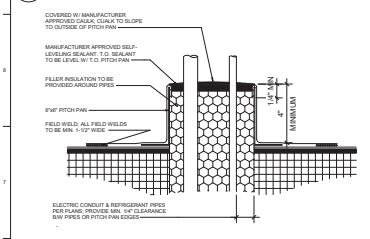

2 ROOF - PITCH PAN DETAIL
3" = 1'-0"

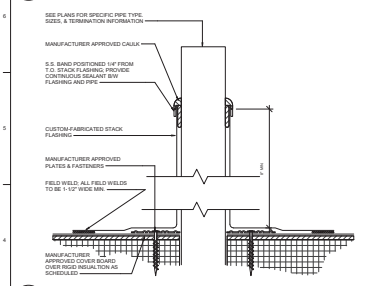

3 ROOF - PIPE PENETRATION DETAIL
3" = 1'-0"

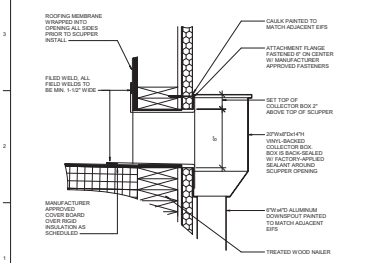

4 ROOF - COLLECTOR BOX & SCUPPER DETAIL
1 1/2" = 1'-0"

D1 ROOF PLAN
1/8" = 1'-0"

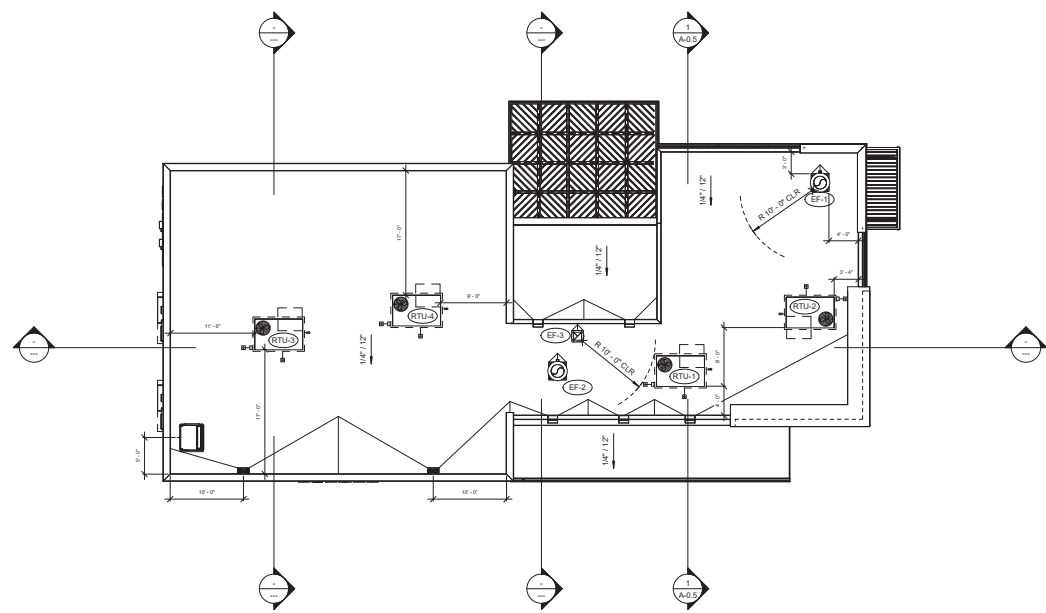

REVISION		
No.	Description	Date

DATE: 04/14/23
REVIEWED BY: Author
PROJECT NO.: 17171

TITLE:
**SHELL BUILDING
ROOF PLAN**

SHEET No.
A-0.2



584 BELLEVUE ROAD, SUITE 3D
ANNAPOLIS, MD 21403
PHONE: 301-364-9880

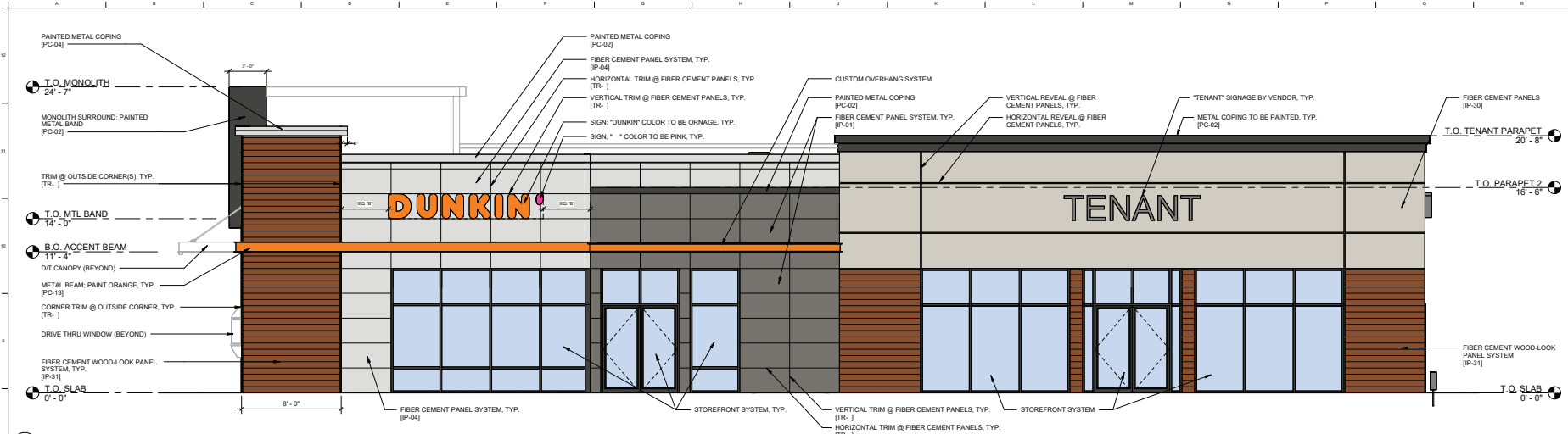

1 NORTH
1/4" = 1'-0"

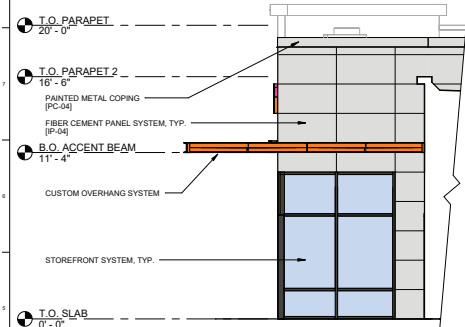

5 EAST - FRONT
1/4" = 1'-0"

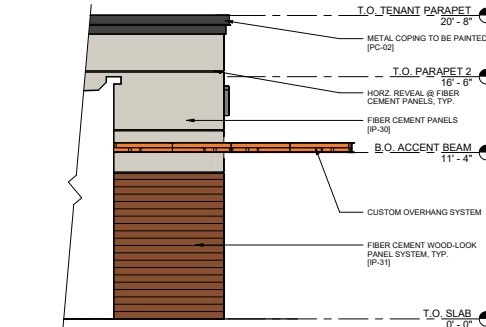

6 WEST - FRONT
1/4" = 1'-0"



3 3D PERSPECTIVE - NE CORNER

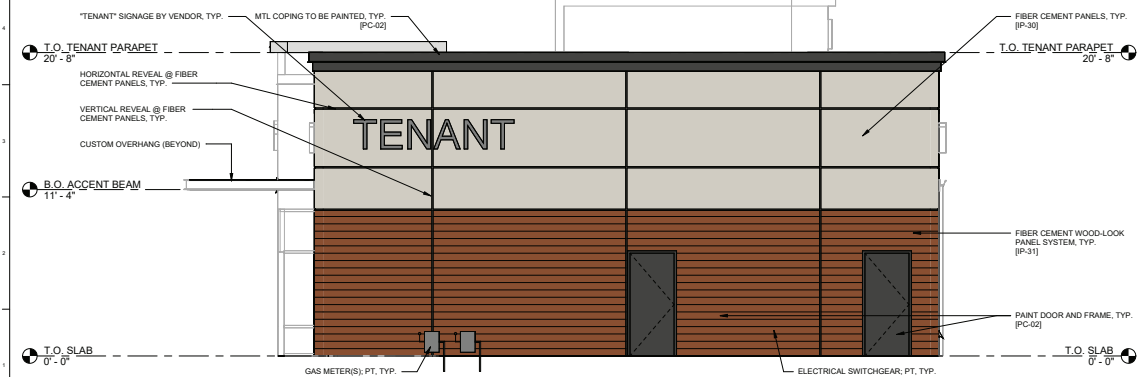

2 WEST
1/4" = 1'-0"

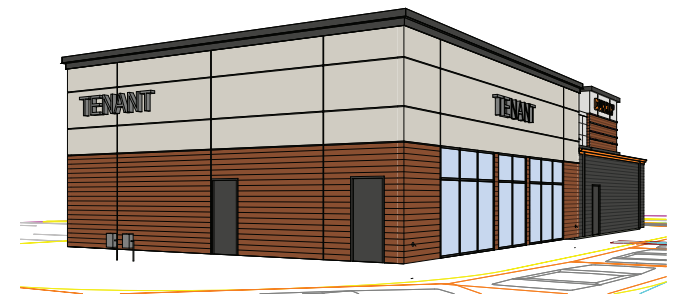

4 3D PERSPECTIVE - SW CORNER



INSPIRE
by Brands
STORE #352620
7853 QUARTERFIELD RD
GLEN BURNIE, MD

REVISION		
No.	Description	Date

DATE: 1/17/23
REVIEWED BY: KRT
PROJECT NO.: 17171

TITLE:
EXTERIOR ELEVATIONS

SHEET No.
A-7

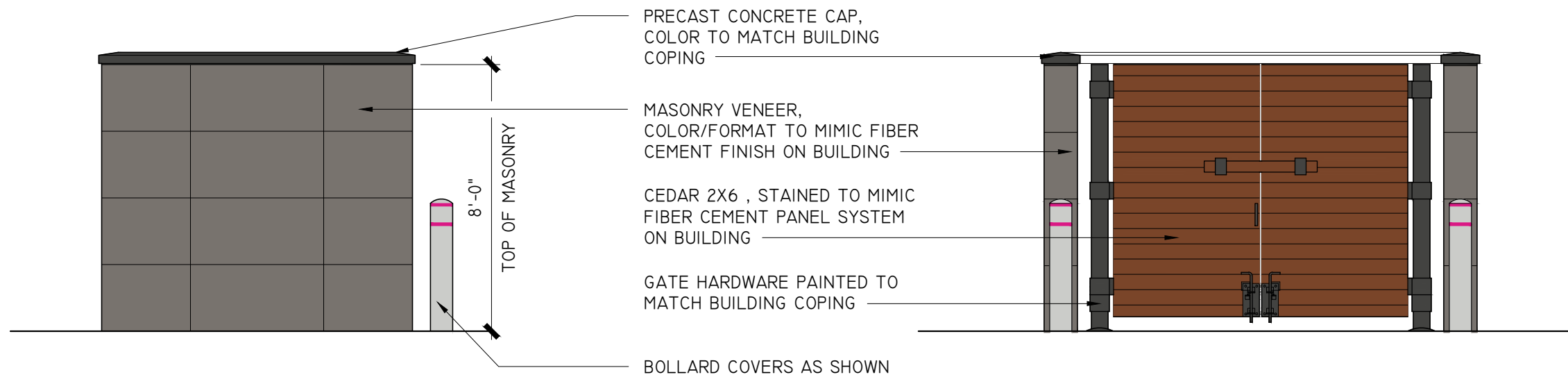

A TYPICAL SIDE/REAR ELEVATION
SCALE: 1/4" = 1'-0"

B FRONT ELEVATION
SCALE: 1/4" = 1'-0"



Quick Service Restaurant | Retail
Design Group, LLC
584 Bellerive Road, Suite 3D Annapolis, MD 21409
Ph. No. (301) 364-9880



FLAVOR PALETTE
NEXT GEN
STORE NUMBER
364188

REVISION		
NO.	DATE	DESCRIPTION
1	05-15-2023	SP COMMENTS



DUNKIN TRASH ENCLOSURE

701 E. IMPERIAL HWY
LA HABRA, CA 90631

SHEET No.:

DATE: 06-09-2023

EXTERIOR FINISH MATERIAL SCHEDULE

FIN.	TAG	DESCRIPTION	NOTES
	AMSV - 01	ADHERED MASONRY STONE VENEER	24" X 36" COLOR MATCH SW "GAUNTLET GRAY"
	AMSV - 02	ADHERED STONE MASONRY VENEER	WALL CAP, COLOR MATCH SW "IRON ORE"
	IP-01	FIBER CEMENT PANEL	COLOR MATCH SW "GAUNTLET GRAY" DUNKIN FIELD
	IP-04	FIBER CEMENT PANEL	COLOR MATCH SW "NEBULOUS WHITE" DUNKIN FIELD
	IP-30	FIBER CEMENT PANEL	COLOR MATCH SW 9165 "GOSSAMER VEIL" TENANT FIELD
	IP-31	FIBER CEMENT PANEL	NICHIHA RUSTIC SERIES "REDWOOD" DUNKIN & TENANT ACCENTS
	PC-02	PAINTED METAL COATING	COLOR MATCH SW "IRON ORE" METAL COPING, ACCENT BAND
	PC-04	PAINTED METAL COATING	COLOR MATCH SW "NEBULOUS WHITE" METAL COPING
	PC-13	PAINTED METAL COATING	DD ORANGE / PMS 165C CANOPES AND ACCENT BAND
	PC-31	PAINTED METAL COATING	COLOR MATCH SW 6005 "FOLKSTONE" TENANT COPING/CANOPY
	PS-01	FIBER CEMENT LAP SIDING	JAMES HARDIE "AGED PWETER" DUNKIN FIELD
	PS-02	FIBER CEMENT LAP SIDING	JAMES HARDIE "IRON GRAY" DUNKIN FIELD
	TR-01/ TR-02	PINK/WHITE METAL TRIM	ALTERNATE IN ROWS WITH WOODTONES TOWER ACCENT



FLAVOR PALETTE
T.B.D.
STORE NUMBER
T.B.D.

REVISION		
NO.	DATE	DESCRIPTION
1	01/18/23	COUNTY COMMENTS
2	04/14/23	COUNTY COMMENTS

DUNKIN DONUTS	
701 E IMPERIAL HWY LA HABRA, CA	SHEET No.:
MATERIAL SCHEDULE N.T.S.	04-14-2023

NOTES

1. .05" x 5" ALUMINUM RETURNS PAINTED TO MATCH PMS 7540C
2. 1" TRIM CAP TO MATCH JEWELITE 313 BRONZE
3. .063" ALUMINUM BACKING
4. GE TETRA MAX 7100K WHITE LED'S
(OR GE REPLACEMENT EQUIVALENT)
5. REMOTE POWER SUPPLY, AS REQUIRED
6. DRAIN HOLES, AS REQUIRED
7. MOUNTING HARDWARE, AS DETERMINED BY SITE CONDITIONS
8. .063" ALUMINUM DISK PAINTED WHITE (REGISTERED "R")
9. 3/16" THICK WHITE ACRYLIC FACE
10. 3M #3630-3123 DUNKIN' ORANGE TRANSLUCENT FILM 1ST SURFACE
11. 3M #3630-1379 DUNKIN' PINK TRANSLUCENT FILM 1ST SURFACE

ADDITIONAL NOTES:

ARTWORK FONT : DUNKIN SANS DISPLAY

CHANNEL LETTER INTERIOR PAINTED REFLECTIVE WHITE

ELECTRICAL : (1) 20-AMP / 120 VOLT CIRCUIT

U.L. LISTED

LED'S TO BE POPULATED FOR EVEN AND CONSISTENT LIGHTING WITHOUT HOT SPOTS OR SHADOWS

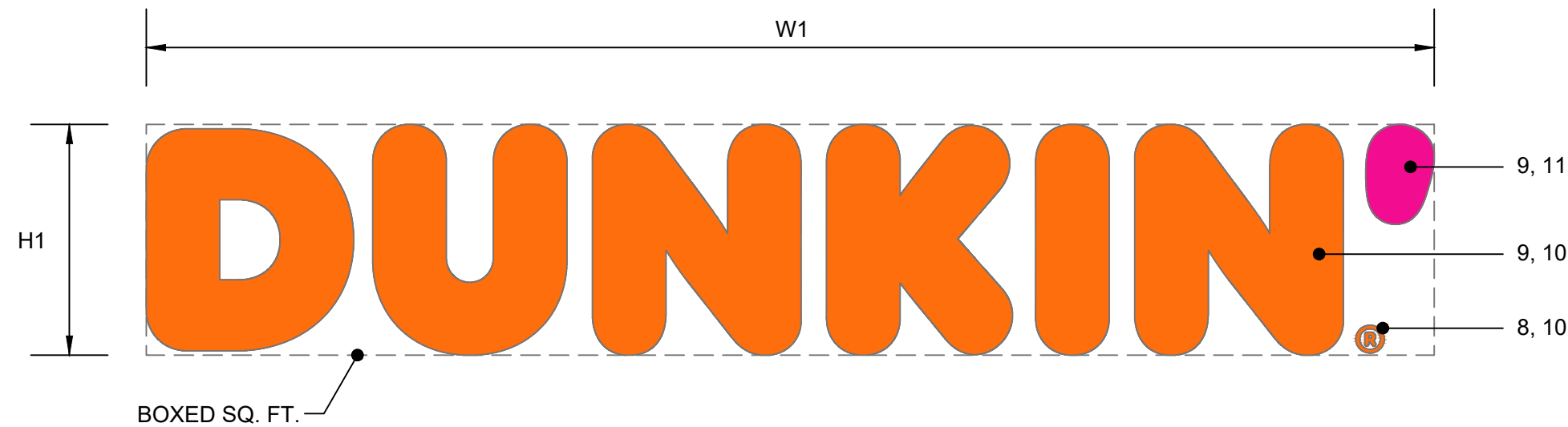

DUNKIN' LED ILLUMINATED CHANNEL LETTERS

SCALE : N.T.S.

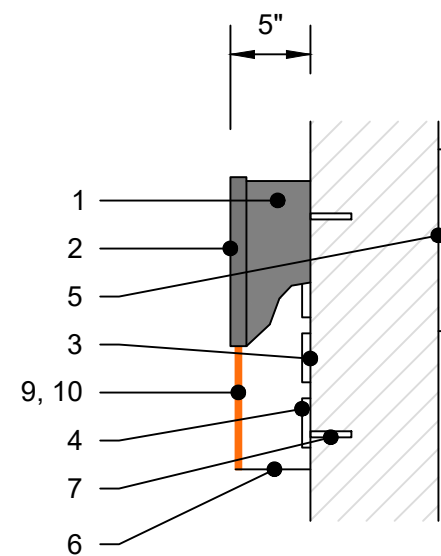

ORANGE "DUNKIN" CROSS SECTION

SCALE : N.T.S.

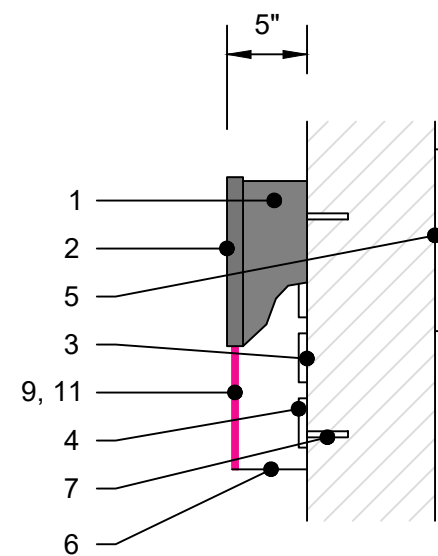

PINK APOSTROPHE (') CROSS SECTION

SCALE : N.T.S.

SIZE	H1	W1	S.F. (BOX)
SMALL	18"	100.25"	12.55'
MEDIUM	24"	133.75"	22.31'
LARGE	30"	167.25"	34.85'
CUSTOM	-	-	-

PMS	VINYL / PAINT
PMS 165 - DUNKIN' ORANGE	3M #3630-3123
PMS 219 - DUNKIN' PINK	3M #3630-1379
PMS 7540C - DUNKIN' GRAY	3M #7725-41
PTE-04 - NEBULOUS WHITE	SW 7063



THE INTENT OF THIS DRAWING IS TO SHOW A CONCEPTUAL REPRESENTATION OF THE PROPOSED SIGNAGE. DUE TO VARIATIONS IN PRINTING DEVICES AND SUBSTRATES THE FINISHED PRODUCT MAY DIFFER SLIGHTLY FROM DRAWINGS.

DD BUILDING & SITE SIGNAGE

" DUNKIN' " CHANNEL SIGN

DATE: 01.25.2022

REV. #16

DUNKIN' BRANDS INC.
CONSTRUCTION SERVICES

DD-BS-01

NOTES

1. 36" GALVANIZED 2-1/4" SQUARE ANCHOR POST WITH 7/16" HOLES OR KNOCKOUTS AT 1" O.C.
2. 5/16" CORNER BOLT AND NUT OR 3/8" BOLT AND NUT USED FOR CONNECTION.
3. SLIDE SECTION INTO THE 36" SECTION OF 2-14" POST ALLOW AT LEAST A MINIMUM OF 6" OVERLAP IN POSTS.
4. 84" GALVANIZED 2" SQUARE SQUARE ANCHOR POST WITH 7/16" HOLES OR KNOCKOUTS AT 1" O.C.
5. DRIVE THE SECTION INTO THE GROUND USING A SLEDGEHAMMER OR DRIVER. THE BASE SHOULD GO INTO THE GROUND UNTIL ROUGHLY 1" OF THE SECTION IS EXPOSED ABOVE THE GROUND.
6. SIGN POLE SUPPORTED MOVEABLE BASE (SPEC. VARIES)

ADDITIONAL NOTES:

ARTWORK FONT : DUNKIN SANS DISPLAY

POSTS INSTALLED IN THIS CONFIGURATION ARE DESIGNED TO BREAK AWAY DURING AN ACCIDENT AND CAN BE REUSED, EVEN AFTER ACCIDENTS.

ADDING NUMBERS TO THE SIGN ONLY APPLICABLE WHEN MULTIPLE CURBSIDE PICKUP STALLS ARE AVAILABLE.

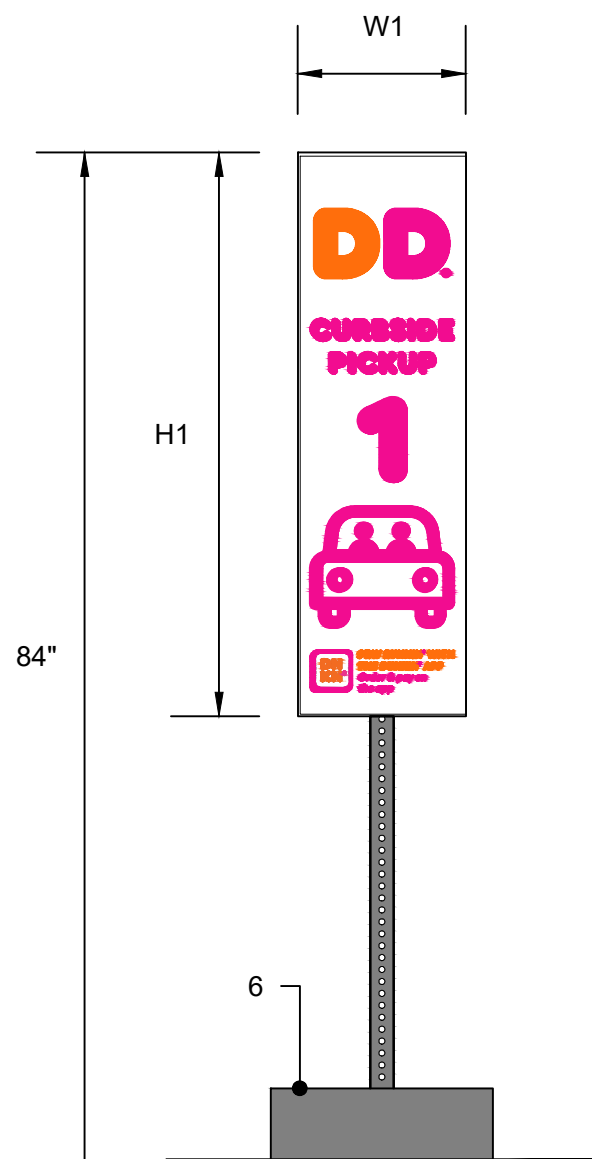

MOVEABLE BASE

OPTION 1 (PREFERRED)

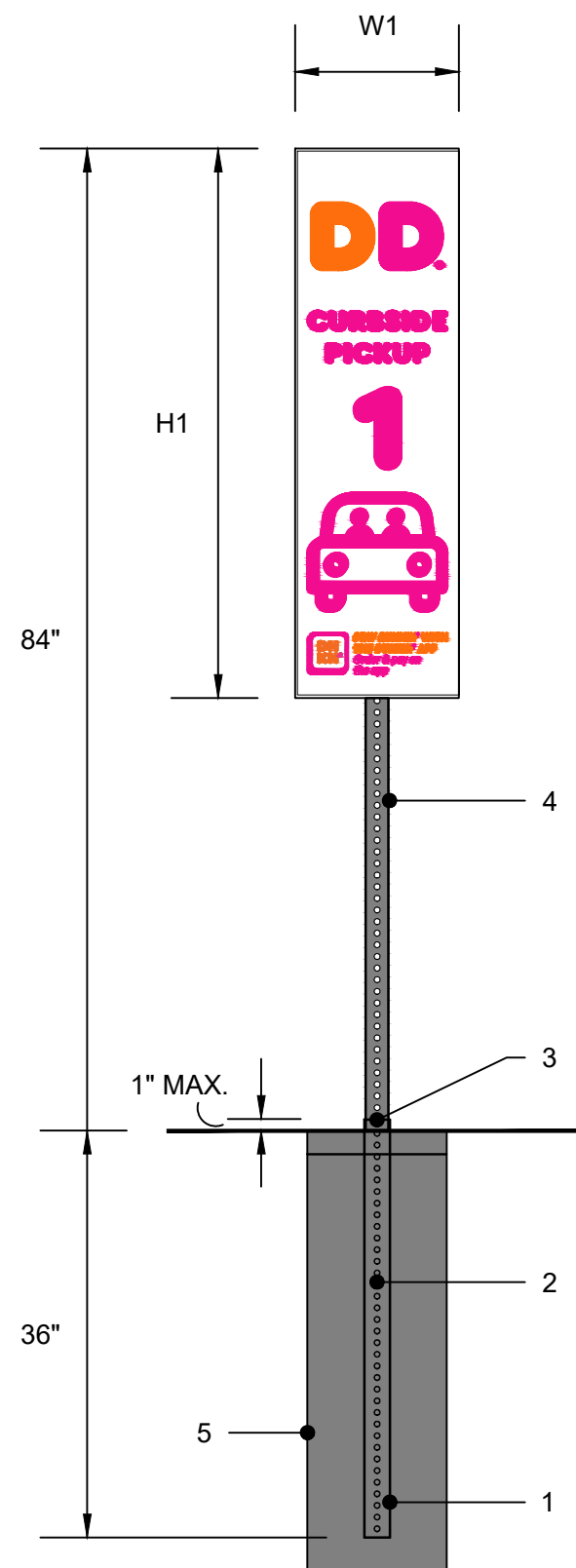

PERMANENT POLE BASE

OPTION 2

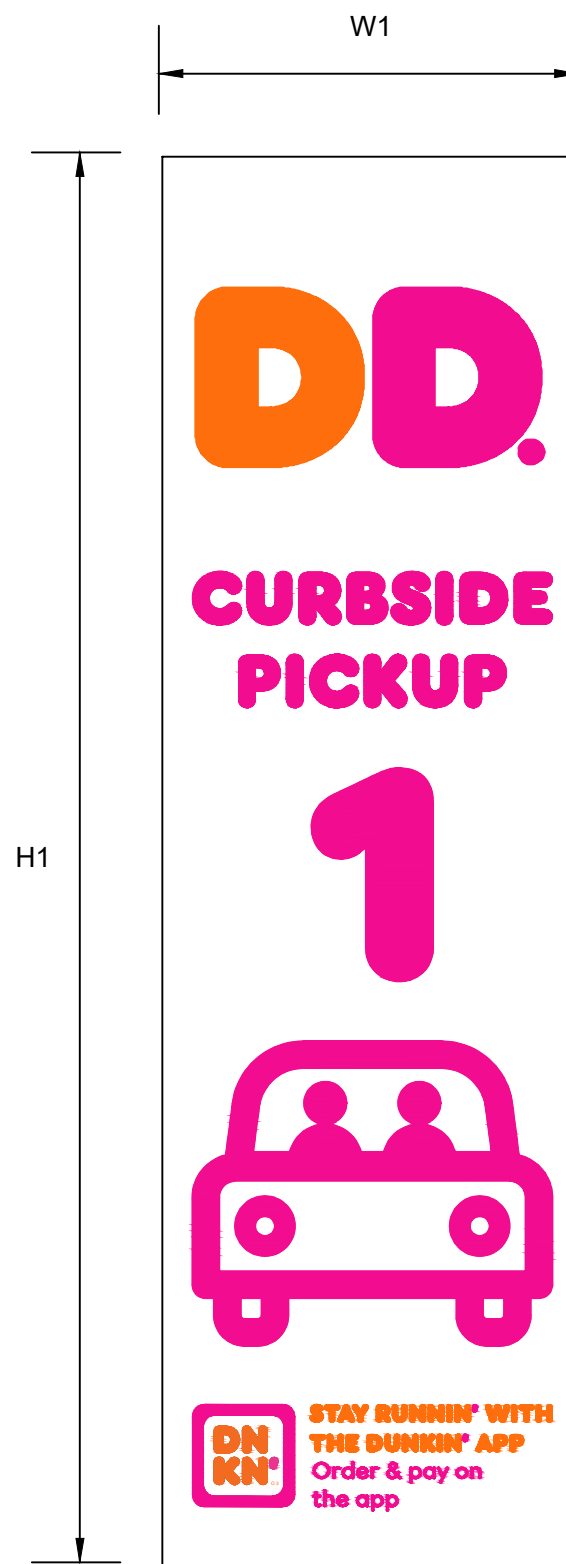

NON-ILLUMINATED
CURBSIDE PICK-UP SIGN

SCALE : N.T.S.

SIZE	H1	W1	D1	S.F. (BOX)
ALL	47"	14"	N/A	4.57'
CUSTOM	-	-	-	-
PMS		VINYL / PAINT		
PMS 165 - DUNKIN' ORANGE		3M #3630-3123		
PMS 219 - DUNKIN' PINK		3M #3630-1379		
PMS 7540C - DUNKIN' GRAY		3M #7725-41		
PTE-04 - NEBULOUS WHITE		SW 7063		



THE INTENT OF THIS DRAWING IS TO SHOW A CONCEPTUAL REPRESENTATION OF THE PROPOSED SIGNAGE. DUE TO VARIATIONS IN PRINTING DEVICES AND SUBSTRATES THE FINISHED PRODUCT MAY DIFFER SLIGHTLY FROM DRAWINGS.

DD BUILDING & SITE SIGNAGE

CURBSIDE PICK-UP SIGN

DATE: 01.25.2022

REV: #16

DUNKIN' BRANDS INC.
CONSTRUCTION SERVICES

DD-SS-CS-01

NOTES

ARTWORK FONT : DUNKIN SANS DISPLAY

SWEEP AND CLEAN THE SURFACE OF THE DRIVEWAY, MAKING SURE IT IS FREE OF DEBRIS.

PAINT THE CONCRETE WITH CONCRETE PRIMER (IF APPLICABLE).

USING DUCT TAPE, SECURE THE STENCIL TO THE DESIRED LOCATION. MAKE SURE THE STENCIL IS STRAIGHT AND CENTERED.

AFTER LETTERS ARE PAINTED AND STENCIL IS REMOVED, TOUCH UP BY HAND ANY VOIDS IN THE LETTERS THAT WERE LEFT BY THE STENCIL.

PAINT THE ADJACENT PARKING STALL LINES.

FOR CONCRETE DRIVEWAY APPLICATION IT IS HIGHLY RECOMMENDED THAT A CONCRETE PRIMER IS USED PRIOR TO PAINTING.

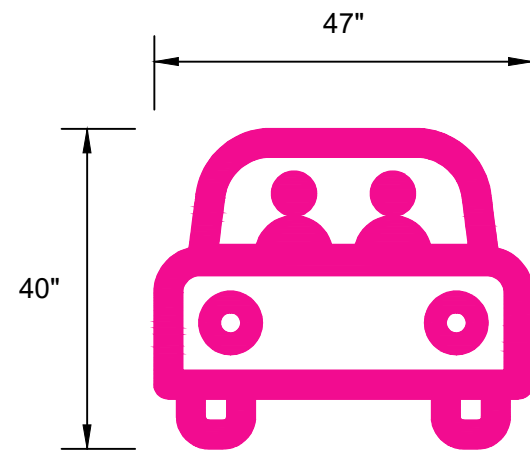
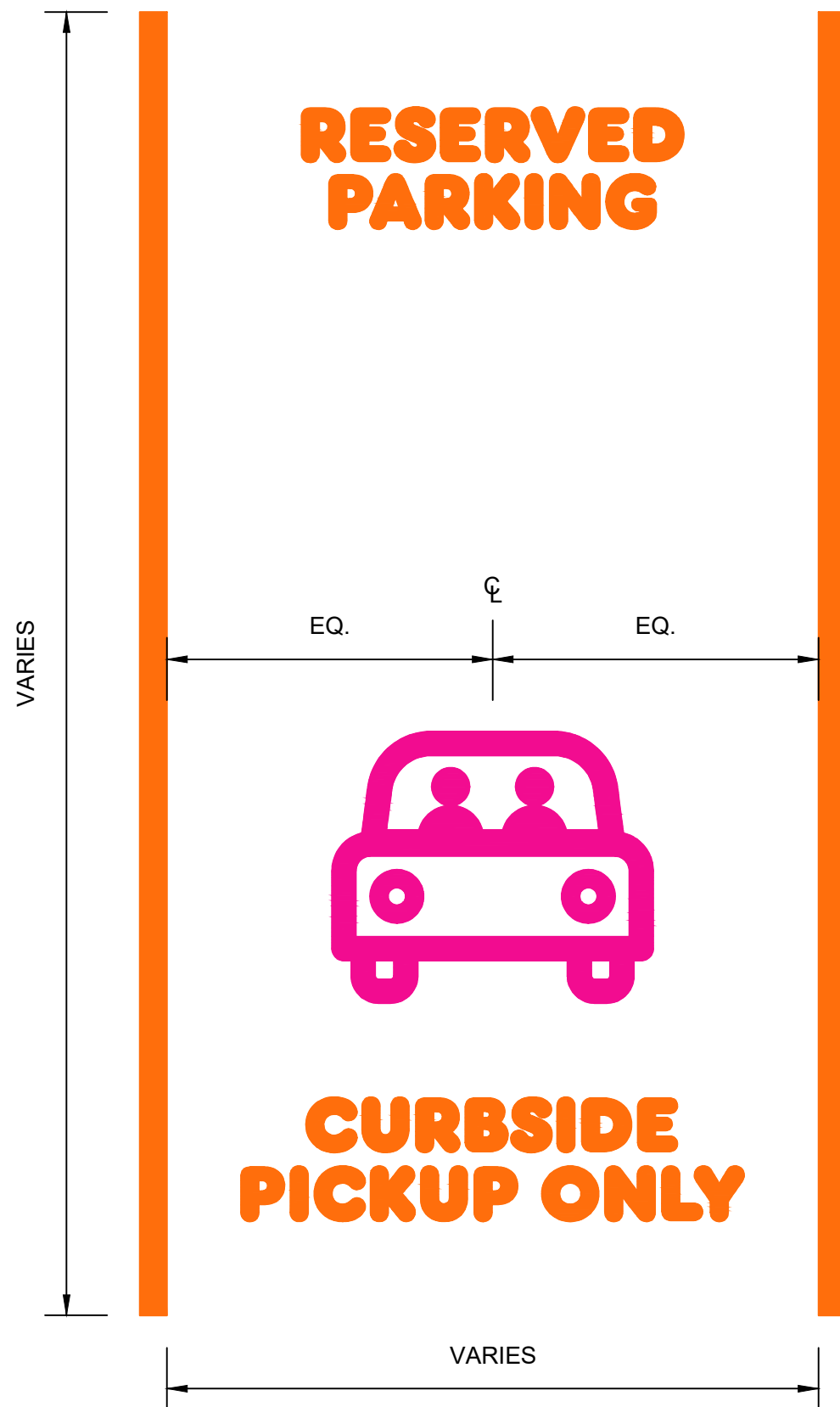

CAR ICON IN FRONT OF STALL
SCALE : N.T.S.



"RESERVED PARKING" SHOULD BE PAINTED ON THE TOP OF THE PARKING STALL (CURB SIDE)
SCALE : N.T.S.

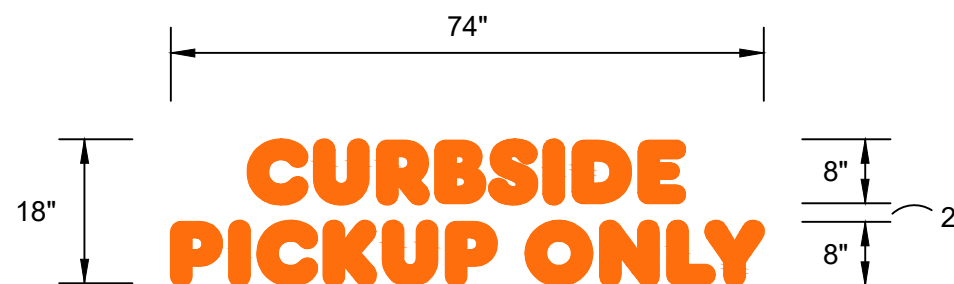

"CURBSIDE PICKUP ONLY" SHOULD BE PAINTED ON THE BOTTOM OF THE PARKING STALL
SCALE : N.T.S.

PMS	VINYL / PAINT
PMS 165 - DUNKIN' ORANGE	3M #3630-3123
PMS 219 - DUNKIN' PINK	3M #3630-1379
PMS 7540C - DUNKIN' GRAY	3M #7725-41
PTE-04 - NEBULOUS WHITE	SW 7063



THE INTENT OF THIS DRAWING IS TO SHOW A CONCEPTUAL REPRESENTATION OF THE PROPOSED SIGNAGE. DUE TO VARIATIONS IN PRINTING DEVICES AND SUBSTRATES THE FINISHED PRODUCT MAY DIFFER SLIGHTLY FROM DRAWINGS.

DD BUILDING & SITE SIGNAGE

CURBSIDE PARKING STALL

DATE: 01.25.2022 REV. #16

DUNKIN' BRANDS INC.
CONSTRUCTION SERVICES

DD-SS-CS-02

NOTES

1. 5" x 1" x .063" ALUMINUM SPACE FRAME
2. 1" ALUMINUM RETAINER
3. 1" x 1" x 1/8" ALUMINUM ANGLE
4. 4" x 4" x .075" SQUARE TUBE SUPPORT PAINTED ORANGE PMS 165 C
5. GE TETRA MAX 7100K WHITE LED'S, AS REQUIRED (OR GE REPLACEMENT EQUIVALENT)
6. LED POWER SUPPLIES, AS REQUIRED
7. .118 CLEAR SOLAR GRADE POLYCARBONATE FACE 2ND SURFACE
8. BACKGROUND COLOR TO BE 403 WHITE BACK-SPRAY
9. 3M #3630-3123 DUNKIN' ORANGE TRANSLUCENT FILM 2ND SURFACE
10. 3M #3630-1379 DUNKIN' PINK TRANSLUCENT FILM 2ND SURFACE
11. 3M #7125-41 DUNKIN' GRAY TRANSLUCENT FILM 2ND SURFACE

ADDITIONAL NOTES:

ARTWORK FONT : DUNKIN SANS DISPLAY

EXTERIOR FINISH : PAINT PANTONE 7540C

INTERIOR FINISH : PAINTED REFLECTIVE WHITE

RETAINERS / FACE REMOVABLE FOR SERVICE ACCESS

DIRECT BURY INSTALLATION PER CODE

(1) 20 AMP / 120 VOLT CIRCUIT

U.L. LISTED

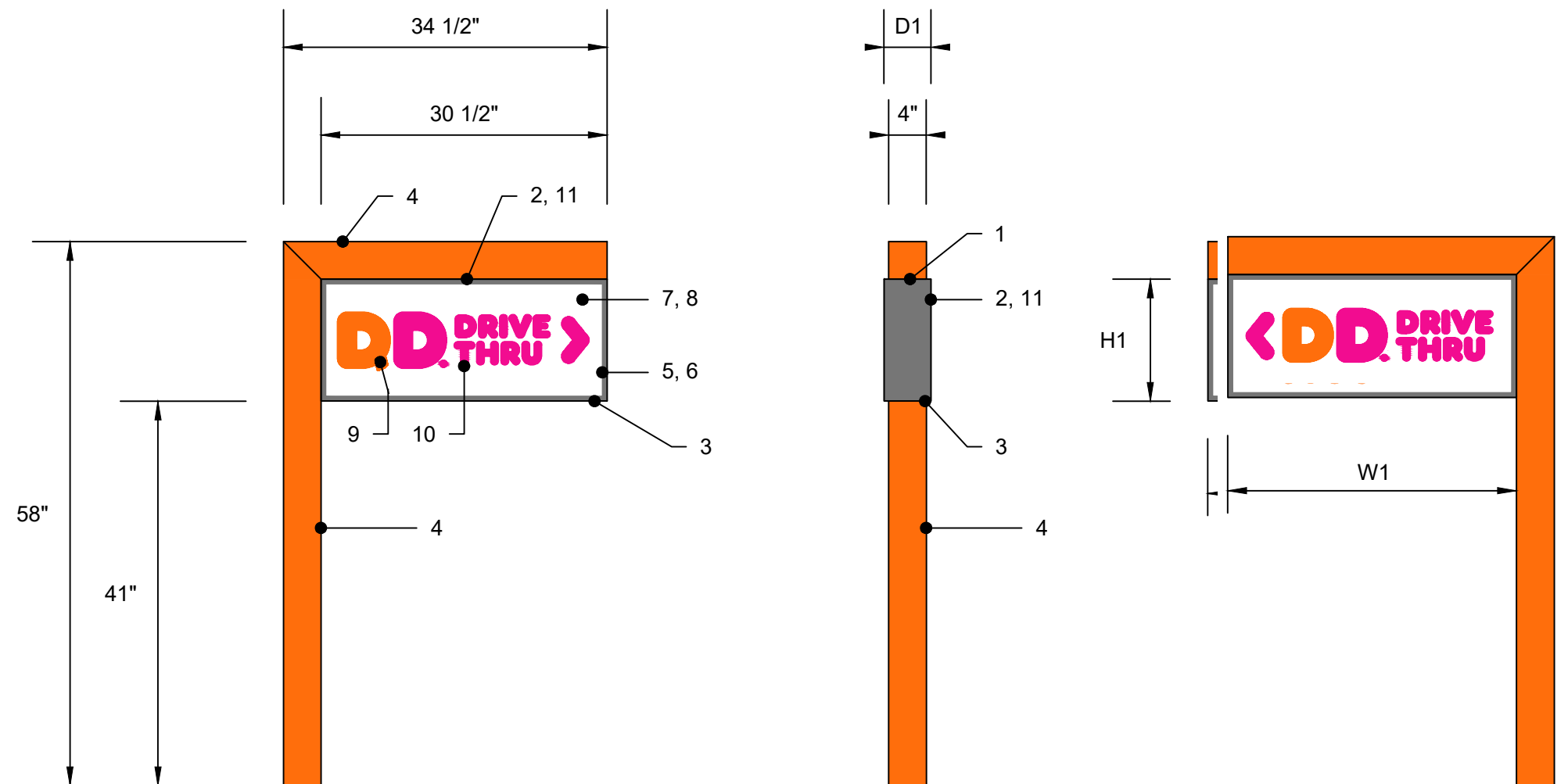

LED ILLUMINATED DIRECTIONAL SIGN (SIDE A)

SCALE : N.T.S.

LED ILLUMINATED DIRECTIONAL SIGN (SIDE C)

SCALE : N.T.S.

LED ILLUMINATED DIRECTIONAL SIGN (SIDE B)

SCALE : N.T.S.

sign faces proposed for development

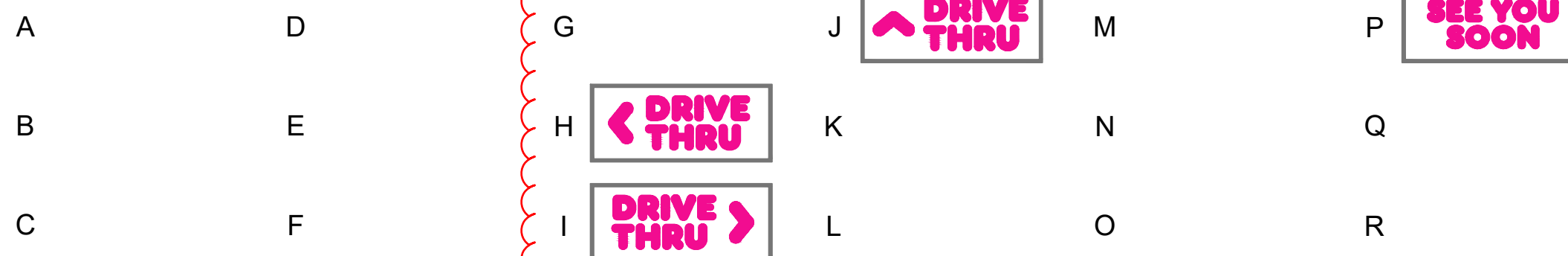

SIZE	H1	W1	D1	S.F. (BOX)
ALL	13"	30.5"	5"	2.75'
CUSTOM	-	-	-	-
PMS		VINYL / PAINT		
PMS 165 - DUNKIN' ORANGE		3M #3630-3123		
PMS 219 - DUNKIN' PINK		3M #3630-1379		
PMS 7540C - DUNKIN' GRAY		3M #7725-41		
PTE-04 - NEBULOUS WHITE		SW 7063		



THE INTENT OF THIS DRAWING IS TO SHOW A CONCEPTUAL REPRESENTATION OF THE PROPOSED SIGNAGE. DUE TO VARIATIONS IN PRINTING DEVICES AND SUBSTRATES THE FINISHED PRODUCT MAY DIFFER SLIGHTLY FROM DRAWINGS.

DD BUILDING & SITE SIGNAGE

DIRECTIONAL SIGNS

DATE: 01.25.2022

REV: #16

DUNKIN' BRANDS INC.
CONSTRUCTION SERVICES

DD-SS-DS-01

FREESTANDING CANOPY

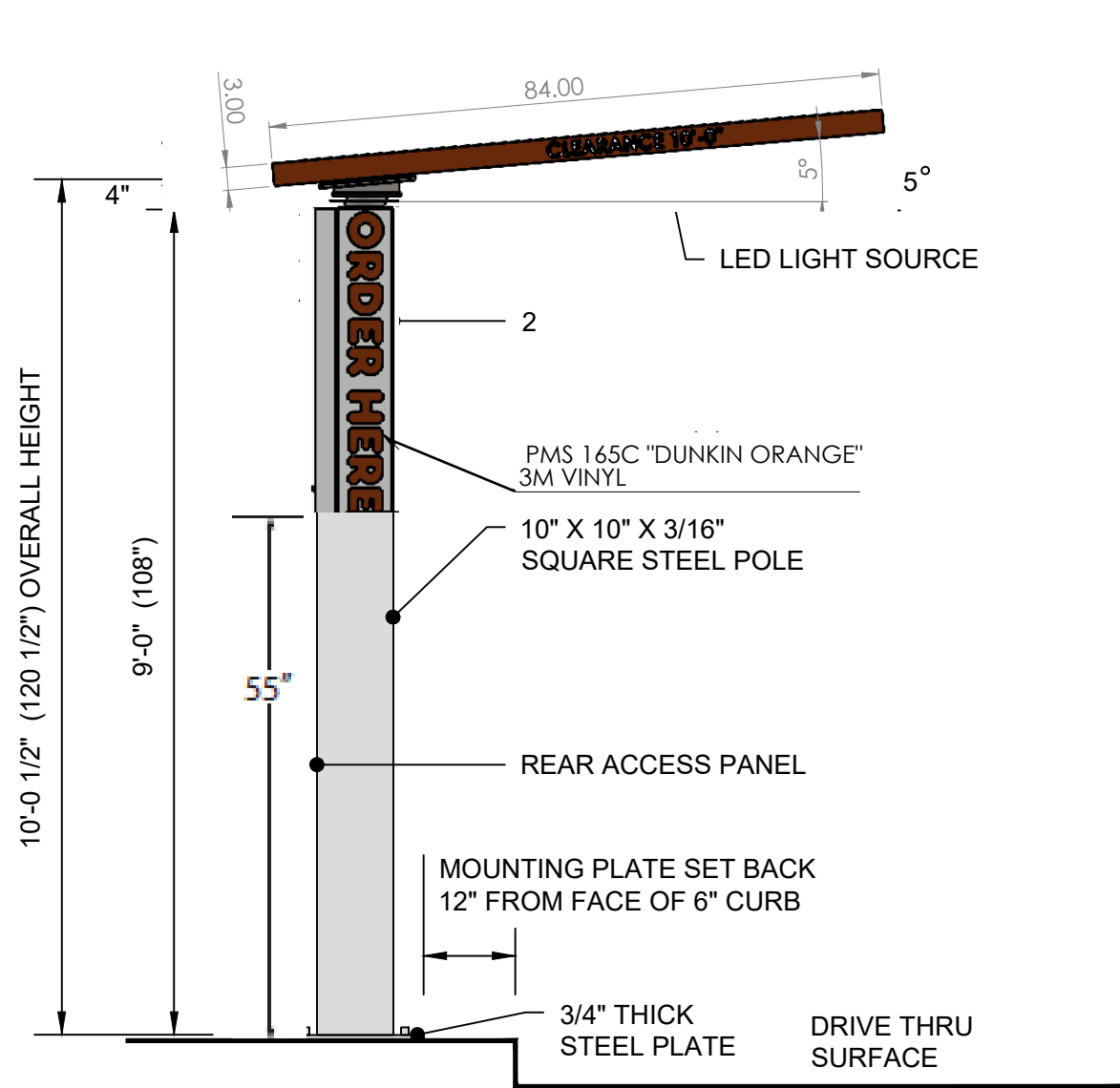

SIDE VIEW (APPROACH)

SCALE : 1/2" = 1'-0"

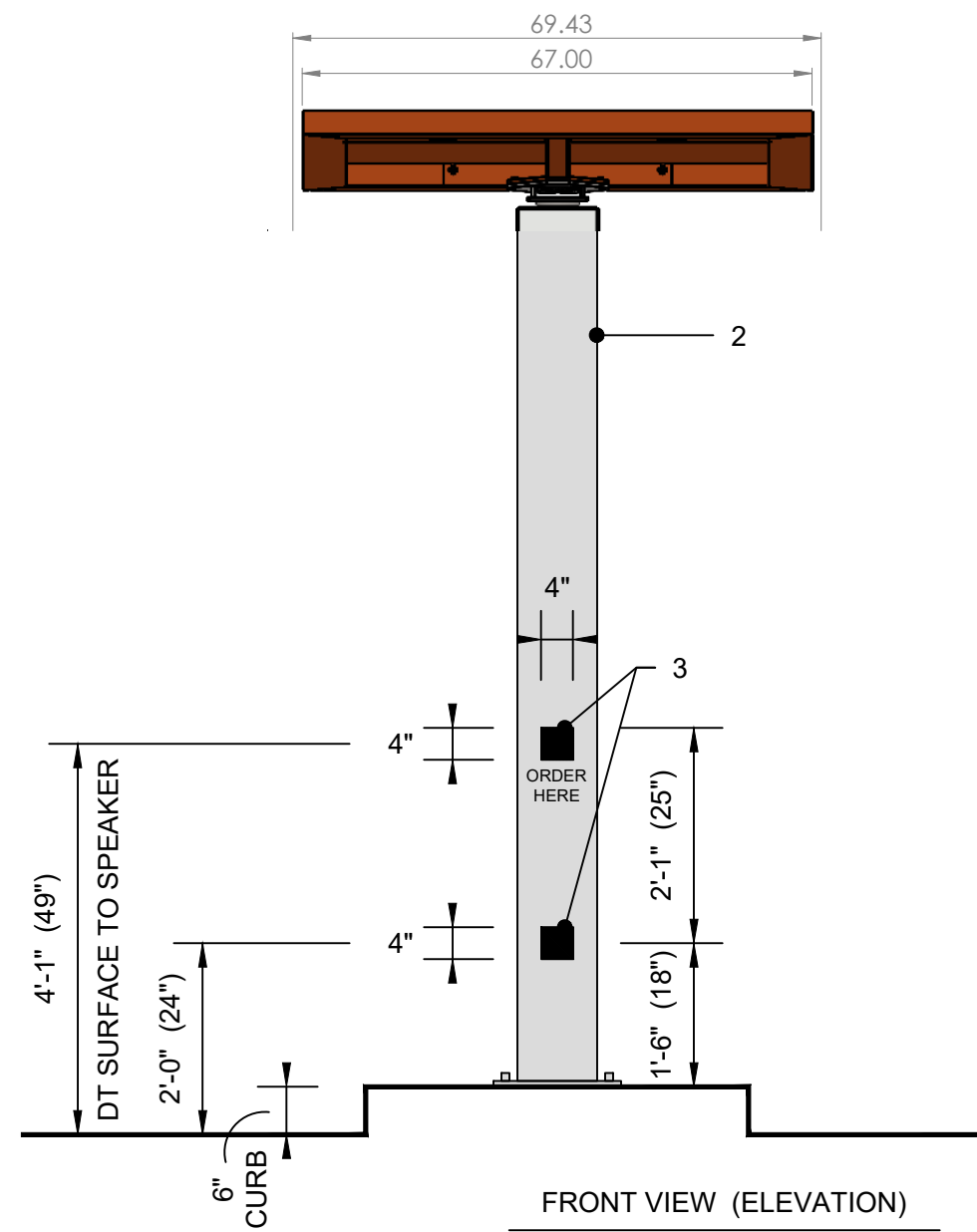

FRONT VIEW (ELEVATION)

SCALE : 1/2" = 1'-0"

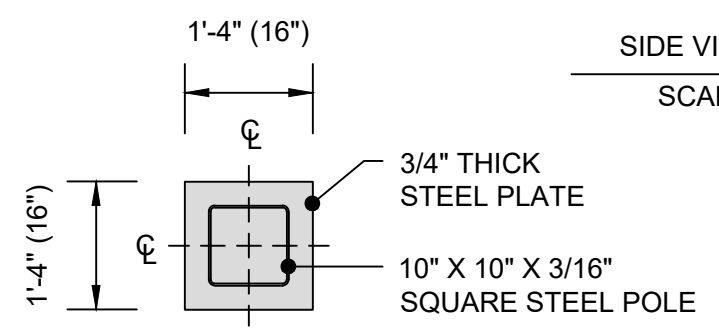

MOUNTING PLATE DETAIL

SCALE : 1/2" = 1'-0"

DUNKIN' BRAND STANDARD - REQUIRED

NOTES

1. PAINT TO MATCH ORANGE PMS 165 C, GLOSS FINISH
2. PAINT TO MATCH PMS COOL GRAY 1 C, GLOSS FINISH
3. BLACK VINYL, ARLON 2100-03. MIC BY OTHERS.
4. BREAKAWAY SWIVEL TOP

ADDITIONAL NOTES:

ARTWORK FONT : DUNKIN SANS DISPLAY
 120 VOLT CIRCUIT, TO BE CONFIRMED BY SITE
 CLEARANCE TO BE CONFIRMED BY SITE
 TOP HAS TWO DOWN LIGHTS

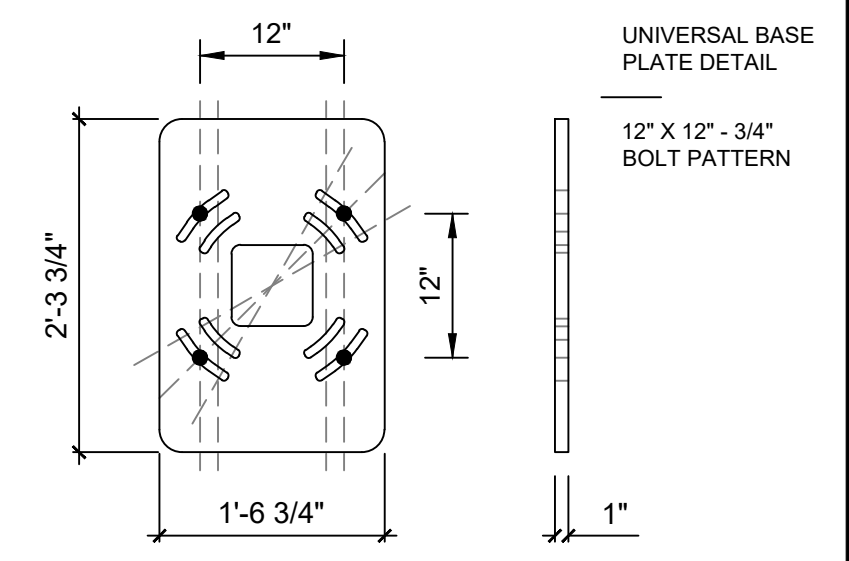

UNIVERSAL BASE
 PLATE DETAIL
 12" X 12" - 3/4"
 BOLT PATTERN

PMS	VINYL / PAINT
PMS 165 - DUNKIN' ORANGE	3M #3630-3123
PMS 219 - DUNKIN' PINK	3M #3630-1379
PMS 7540C - DUNKIN' GRAY	3M #7725-41
PMS COOL GRAY 1C	3M #7725-11



THE INTENT OF THIS DRAWING IS TO SHOW A CONCEPTUAL REPRESENTATION OF THE PROPOSED SIGNAGE. DUE TO VARIATIONS IN PRINTING DEVICES AND SUBSTRATES THE FINISHED PRODUCT MAY DIFFER SLIGHTLY FROM DRAWINGS.

DD BUILDING & SITE SIGNAGE
 ILLUMINATED DRIVE THRU CANOPY SIGN

DATE: 01.25.2022 REV: #16
 DUNKIN' BRANDS INC.
 CONSTRUCTION SERVICES

DD-SS-DT-01

NOTES

1. MENUBOARD IS POWDER COATED OR PAINTED TO MATCH PTE-04 NEBULOUS WHITE (CABINET, BASE CLADDING, DOOR FRAMES & EXTENDER FRAMES)
2. SAMSUNG OHF SERIES DISPLAY MENUBOARDS, OH55F - 55"

ADDITIONAL NOTES:

ARTWORK FONT : DUNKIN SANS DISPLAY

ELEMENT PROVIDED BY NCR TECHNOLOGY PACKAGE

TO BE USED IN CONJUNCTION WITH FREESTANDING CANOPY

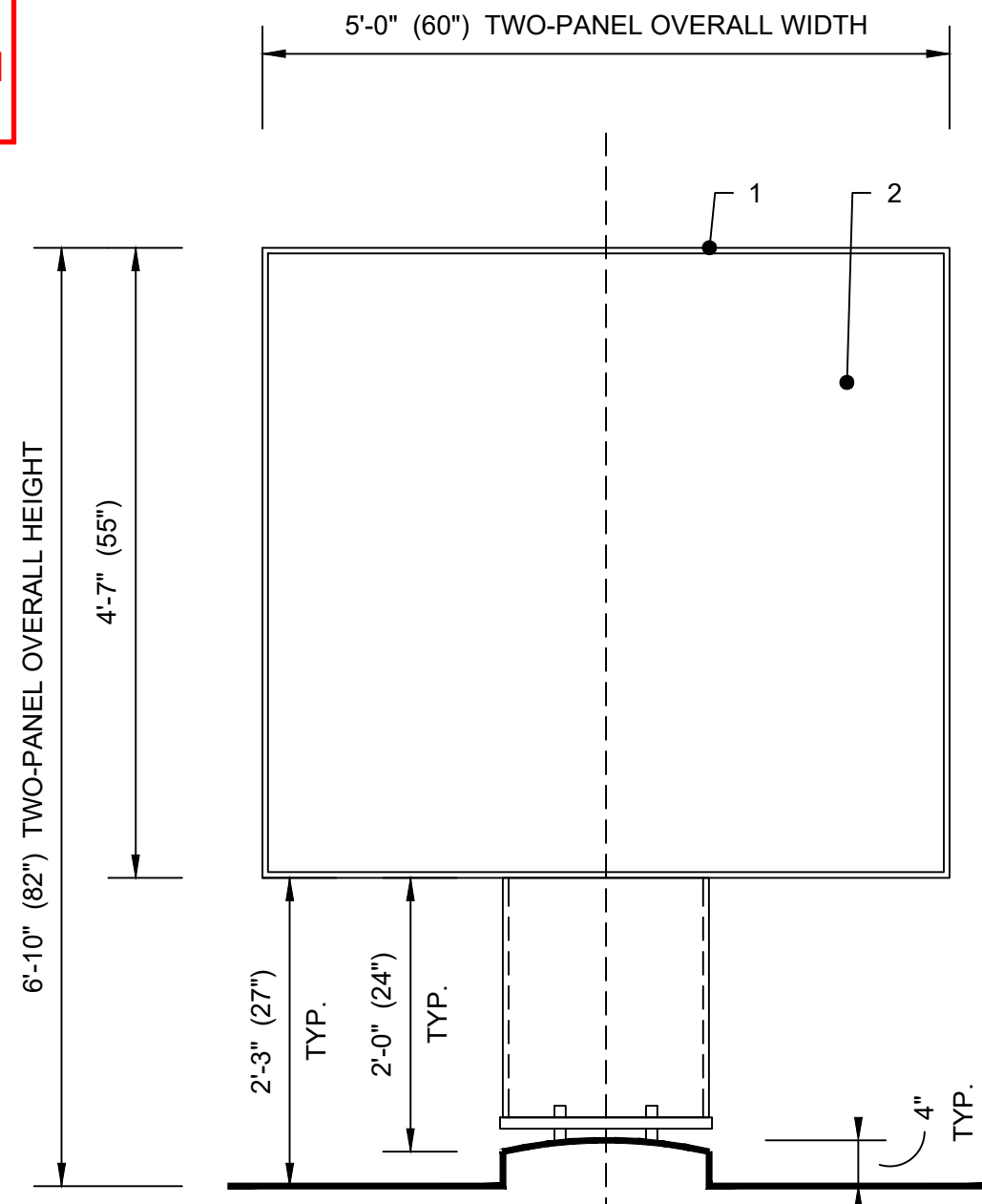

FRONT VIEW (TWO & THREE PANEL)
SCALE : 3/4" = 1'-0"

DUNKIN' BRAND STANDARD - REQUIRED

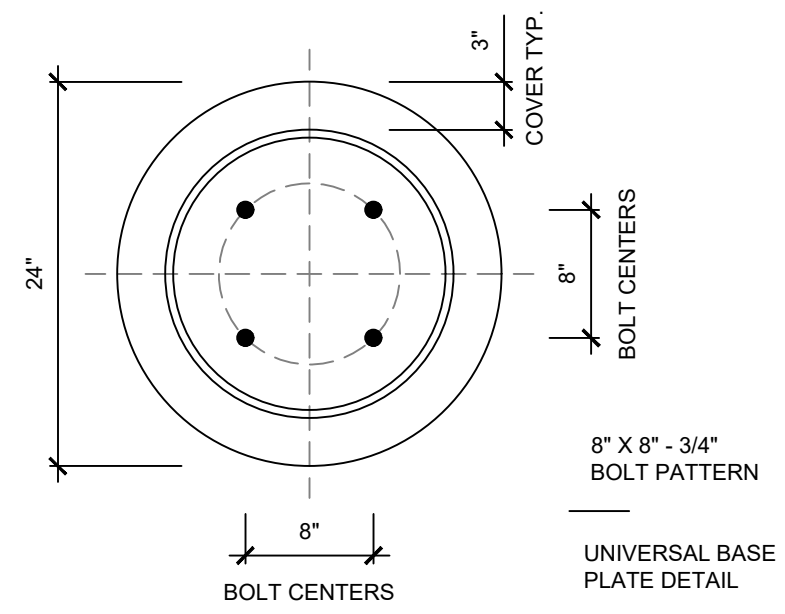

PMS	VINYL / PAINT
PMS 165 - DUNKIN' ORANGE	3M #3630-3123
PMS 219 - DUNKIN' PINK	3M #3630-1379
PMS 7540C - DUNKIN' GRAY	3M #7725-41
PTE-04 - NEBULOUS WHITE	SW 7063

example display - static image may change with seasonal product offering



THE INTENT OF THIS DRAWING IS TO SHOW A CONCEPTUAL REPRESENTATION OF THE PROPOSED SIGNAGE. DUE TO VARIATIONS IN PRINTING DEVICES AND SUBSTRATES THE FINISHED PRODUCT MAY DIFFER SLIGHTLY FROM DRAWINGS.

DD BUILDING & SITE SIGNAGE
MULTIPLE PANEL DIGITAL MENU BOARDS

DATE: 01.25.2022 REV. #16
DUNKIN' BRANDS INC. CONSTRUCTION SERVICES

DD-SS-DT-09

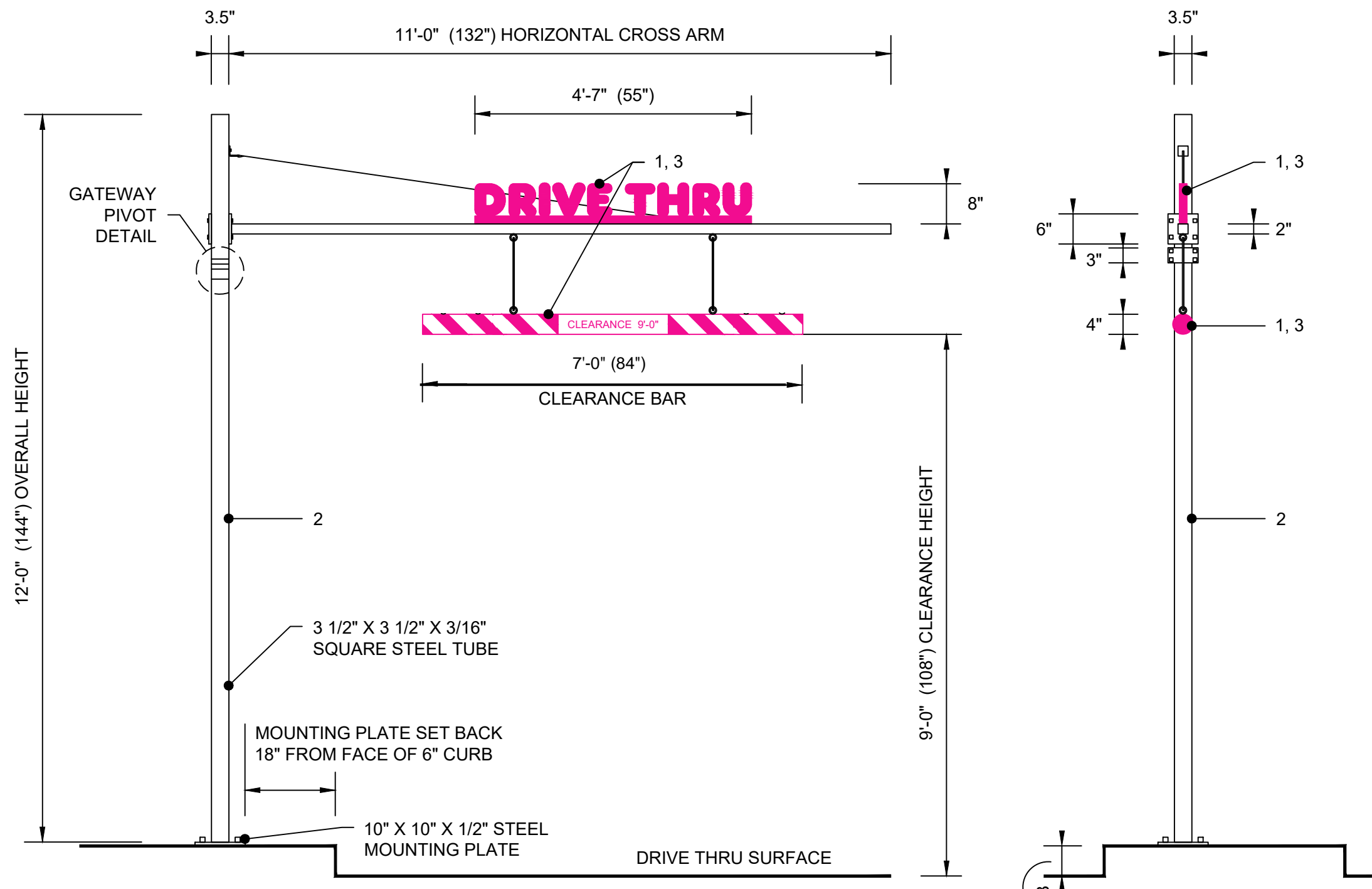

SIDE VIEW (APPROACH)
SCALE : 1/2" = 1'-0"

SIDE VIEW (ELEVATION)
SCALE : 1/2" = 1'-0"

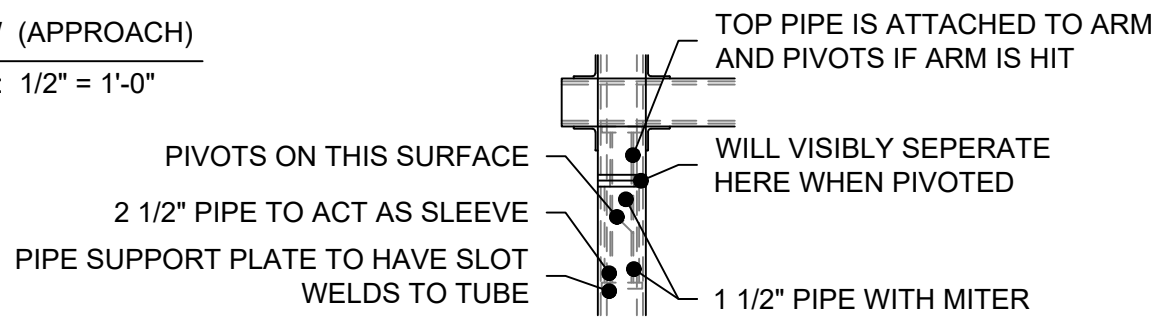

GATEWAY PIVOT DETAIL
SCALE : 3/4" = 1'-0"

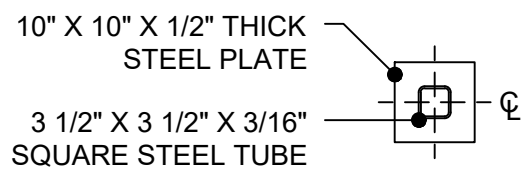

MOUNTING PLATE DETAIL
SCALE : 1/2" = 1'-0"

NOTES

1. PAINT TO MATCH PINK PMS 219 C, GLOSS FINISH
2. PAINT TO MATCH PTE-04 NEBULOUS WHITE, GLOSS FINISH
3. OPTIONAL REFLECTIVE FILM;
3M IJ680CR-10 SCOTCHLITE REFLECTIVE
MCS (LATEX OR SOLVENT INKS)
8519 LUSTER PROTECTIVE LAMINATE PRINTED TO MATCH ...

- PMS 165 DUNKIN' ORANGE
- PMS 219 DUNKIN' PINK
- PMS 7540C DUNKIN' GRAY
- PTE-04 NEBULOUS WHITE

ADDITIONAL NOTES:

ARTWORK FONT : DUNKIN SANS DISPLAY
120 VOLT CIRCUIT, TO BE CONFIRMED BY SITE
CLEARANCE TO BE CONFIRMED BY SITE

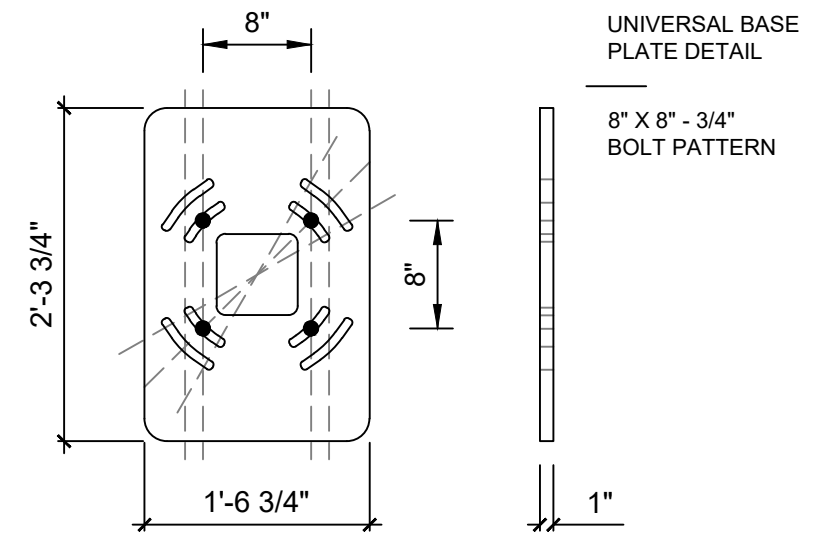

PMS	VINYL / PAINT
PMS 165 - DUNKIN' ORANGE	3M #3630-3123
PMS 219 - DUNKIN' PINK	3M #3630-1379
PMS 7540C - DUNKIN' GRAY	3M #7725-41
PTE-04 - NEBULOUS WHITE	SW 7063



THE INTENT OF THIS DRAWING IS TO SHOW A CONCEPTUAL REPRESENTATION OF THE PROPOSED SIGNAGE. DUE TO VARIATIONS IN PRINTING DEVICES AND SUBSTRATES THE FINISHED PRODUCT MAY DIFFER SLIGHTLY FROM DRAWINGS.

DD BUILDING & SITE SIGNAGE
NON-ILLUMINATED DRIVE THRU STRUCTURE

DATE: 01.25.2022 REV. #16
DUNKIN' BRANDS INC.
CONSTRUCTION SERVICES

DD-SS-DT-07