

**CITY OF LA HABRA
PUBLIC WORKS AGREEMENT FOR
MONTE VISTA STREET REHABILITATION PROJECT
FISCAL YEAR 2022-2023
CITY PROJECT NO. 2-R-22**

THIS AGREEMENT (herein "Agreement"), is made and entered into this 17th day of June, 2024 and between the **CITY OF LA HABRA**, a municipal corporation (herein "City") and **GENTRY BROTHERS INC** (herein "Contractor"). The parties hereto agree as follows:

W I T N E S S E T H :

A. WHEREAS, City requires the construction of street improvements as set forth more fully in this Agreement.

B. WHEREAS, Contractor represents to City that Contractor is qualified to perform said work and has submitted a proposal to City for the same.

C. WHEREAS, City desires to have Contractor perform said services on the terms and conditions set forth herein.

D. WHEREAS, no official or employee of City has a financial interest, within the provisions of Sections 1090-1092 of the California Government Code, in the subject matter of this Agreement.

NOW, THEREFORE, for and in consideration of the mutual covenants and conditions contained herein and for good and valuable consideration, the receipt and sufficiency of which is acknowledged by both parties, City and Contractor hereby agree as follows:

1.0 DEFINITIONS

1.1 Definitions. As used in this Agreement, the following definitions shall be applicable:

- (a) Contractor. Contractor shall mean Gentry Brothers Inc, a California corporation located at 384 Live Oak Ave., Irwindale, CA 91706.
- (b) City. City shall mean the City of La Habra, a Municipal Corporation and General Law City, located at 110 E. La Habra Blvd, La Habra, California 90631.
- (c) City Council. City Council shall mean the City Council of the City of La Habra.
- (d) Contract Officer shall mean the person designated by the City Manager or City Engineer of City and shall have the duties set forth in Section 5.2.
- (e) Services. Services shall mean the services to be performed by the Contractor pursuant to this Agreement.

- (f) Satisfactory. Satisfactory shall mean satisfactory to the City Manager or his/her designee.

2.0 SERVICES OF CONTRACTOR

2.1 Scope of Services. In compliance with all terms and conditions of this Agreement, the Contractor shall provide those services specified in the "Scope of Services" attached hereto as Exhibit "A" and incorporated herein by this reference, which services may be referred to herein as the "services" or "work" hereunder. As a material inducement to the City entering into this Agreement, Contractor represents and warrants that Contractor is a provider of first class work and services and Contractor is experienced in performing the work and services contemplated herein and, in light of such status and experience, Contractor covenants that it shall follow the highest professional standards in performing the work and services required hereunder and that all materials will be of good quality, fit for the purpose intended.

2.2 Documents Included in Contract. This contract consists of this Agreement and any Exhibits, which are incorporated herein by this reference. In the event of an inconsistency, the terms of this Agreement shall govern.

2.3 Compliance with Law. All services rendered hereunder shall be provided in accordance with all ordinances, resolutions, statutes, rules, and regulations of the City and any Federal, State or local governmental agency having jurisdiction in effect at the time service is rendered, including but not limited to, the claims procedure set forth in Public Contract Code Section 9204, a summary of which is attached to this agreement as Exhibit "D."

2.4 Licenses, Permits, Fees and Assessments. Contractor shall obtain at its sole cost and expense such licenses, permits and approvals as may be required by law for the performance of the services required by this Agreement, including registration with the Department of Industrial Relations of the State of California as required by Labor Code Section 1725.5 before commencing performance under this Agreement. Contractor shall have the sole obligation to pay for any fees, assessments and taxes, plus applicable penalties and interest, which may be imposed by law and arise from or are necessary for the Contractor's performance of the services required by this Agreement, and shall indemnify, defend and hold harmless City against any such fees, assessments, taxes penalties or interest levied, assessed or imposed against City hereunder. Contractor shall be responsible for all subcontractors' compliance with this Section 2.4.

2.5 Familiarity with Work. By executing this Contract, Contractor warrants that Contractor (a) has thoroughly investigated and considered the scope of services to be performed, (b) has carefully considered how the services should be performed, and (c) fully understands the facilities, difficulties and restrictions attending performance of the services under this Agreement. If the services involve work upon any site, Contractor warrants that Contractor has or will investigate the site and is or will be fully acquainted with the conditions there existing, prior to commencement of services hereunder. Should Contractor discover any latent or unknown conditions, which will materially affect the performance of the services hereunder, Contractor shall immediately inform the City of such fact and shall not proceed except at Contractor's risk until written instructions are received from the Contract Officer.

2.6 Standard of Performance. Contractor, its subcontractors and their employees, in the performance of Contractor's work under this Agreement shall be responsible for exercising the degree of skill and care required by customarily accepted good professional practices and procedures used in the Contractor's field.

Any costs for failure to meet the foregoing standard or to correct otherwise defective work that requires re-performance of the work, shall be borne in total by the Contractor and not by the City. The failure of a project to achieve the performance goals and objectives stated in this Agreement is not a basis for requesting re-performance unless the work conducted by Contractor and/or its subcontractors is deemed by the City to have failed the foregoing standard of performance.

In the event Contractor fails to perform in accordance with the above standard:

1. Contractor will re-perform, at its own expense, any task which was not performed to the reasonable satisfaction of City. Any work re-performed pursuant to this paragraph shall be completed within the time limitations originally set forth for the specific task involved. Contractor shall work any overtime required to meet the deadline for the task at no additional cost to the City;
2. The City shall provide a new schedule for the re-performance of any task pursuant to this paragraph in the event that re-performance of a task within the original time limitations is not feasible; and
3. The City shall have the option to direct Contractor not to re-perform any task which was not performed to the reasonable satisfaction of the City Engineer pursuant to application of (1) and (2) above. In the event the City directs Contractor not to re-perform a task, the City shall negotiate a reasonable settlement for satisfactory work performed. No previous payment shall be considered a waiver of the City's right to reimbursement.

Nothing contained in this section is intended to limit any of the rights or remedies which the City may have under law.

2.7 Care of Work. The Contractor shall adopt reasonable methods during the life of the Agreement to furnish continuous protection to the work, and the equipment, materials, papers, documents, plans, studies and/or other components thereof to prevent losses or damages, and shall be responsible for all such damages, to persons or property, until acceptance of the work by City, except such losses or damages as may be caused by City's own negligence.

2.8 Further Responsibilities of Parties. Both parties agree to use reasonable care and diligence to perform their respective obligations under this Agreement. Both parties agree to act in good faith to execute all instruments, prepare all documents and take all actions as may be reasonably necessary to carry out the purposes of this Agreement. Unless hereafter specified, neither party shall be responsible for the service of the other. Contractor shall require all subcontractors to comply with the provisions of this agreement.

2.9 Additional Services. City shall have the right at any time during the performance of the services, without invalidating this Agreement, to order extra work beyond that specified in the Scope of Services or make changes by altering, adding to or deducting from said work. No such extra work may be undertaken unless a written change order is first given by the Contract Officer to the Contractor, incorporating therein any adjustment in (i) the Contract Sum as set forth in Section 3.1, and/or (ii) the time to perform this Agreement, which said adjustments are subject to the written approval of the Contractor. Any increase in compensation of twenty five percent (25%) or less of the Contract Sum, or in the time to perform of one hundred eighty (180) days or less may be approved by the Contract Officer. Any increases, taken either separately or cumulatively, that result in the Contract Sum exceeding \$25,000 must be approved by the City Council. It is expressly understood by Contractor that the provisions of this Section shall not apply to services specifically set forth in the Scope of Services or reasonably contemplated therein. Contractor hereby acknowledges that it

accepts the risk that the services to be provided pursuant to the Scope of Services may be more costly or time consuming than Contractor anticipates and that Contractor shall not be entitled to additional compensation therefore.

2.10 Prevailing Wage Laws. Contractor represents and warrants that it is registered with the Department of Industrial Relations pursuant to SB 854 and Labor Code 1725.5. Contractor shall ensure that its subcontractors comply with said requirements. In accordance with Labor Code Section 1770 et seq., the Director of the Department of Industrial Relations of the State of California has ascertained a general prevailing rate of wages, which is the minimum amount, which shall be paid to all workers employed to perform the work pursuant to this Agreement. A copy of the general prevailing wage rate determination is on file in the Office of the City Clerk and is hereby incorporated by reference into this Agreement. In accordance with the provisions of Labor Code Section 1810 et seq., eight (8) hours is the legal working day. Contractor must forfeit to the City Twenty Five Dollars (\$25.00) a day for each worker who works in excess of the minimum working hours when Contractor does not pay overtime. Contractor is required to post a copy of such wage rates at all times at the contract site. The statutory penalties for failure to pay prevailing wage or to comply with State wage and hour laws will be enforced. Contractor also shall comply with State law requirements to maintain payroll records and shall provide for certified records and inspection of records as required by California Labor Code Section 1770 et. seq., including Section 1776. Contractor shall comply with all statutory requirements relating to the employment of apprentices.

3.0 COMPENSATION

3.1 Contract Sum. For the services rendered pursuant to this Agreement, the Contractor shall be compensated as specified herein, but not exceeding the maximum contract amount of eight hundred fifty-eight thousand nine hundred forty Dollars (\$858,940.00) (herein "Contract Sum"), except as provided in Section 2.9. The Contract Sum shall include the attendance of Contractor at all project meetings reasonably deemed necessary by the City; Contractor shall not be entitled to any additional compensation for attending said meetings.

3.2 Progress Payments. Prior to the first day of the month, during the progress of the work, commencing on the day and month specified in the Agreement, Contractor shall submit to the Contract Officer a complete itemized statement of all labor and materials incorporated into the work during the preceding month and the portion of the contract sum applicable thereto. Upon approval in writing by the Contract Officer, payment shall be made in thirty (30) days. City shall pay Contractor a sum based upon ninety-five percent (95%) of the contract price apportionment of the labor and materials incorporated into the work under the contract during the month covered by said statement. The remaining five percent (5%) thereof shall be retained as performance security. Refer to Section 8.4 of this Agreement for retention of funds.

4.0 PERFORMANCE SCHEDULE

4.1 Time of Essence. Time is of the essence in the performance of this Agreement.

4.2 Schedule of Performance. Contractor shall commence the services pursuant to this Agreement upon receipt of a written notice to proceed and shall perform all services within the time period(s) established in Exhibit "A", and incorporated herein by this reference. When requested by the Contractor, extensions to the time period(s) specified in the Scope of Services may be approved in writing by the Contract Officer.

4.3 Force Majeure. The time period(s) specified in the Scope of Services for performance of the services rendered pursuant to this Agreement shall be extended because of any delays due to unforeseeable

causes beyond the control and without the fault or negligence of the Contractor, including, but not restricted to, acts of God or of the public enemy, unusually severe weather, fires, earthquakes, floods, epidemics, quarantine restrictions, riots, strikes, freight embargoes, wars, litigation, and/or acts of any governmental agency, including the City, if the Contractor shall within ten (10) days of the commencement of such delay notify the Contract Officer in writing of the causes for the delay. The Contract Officer shall ascertain the facts and the extent of delay, and extend the time for performing the services for the period of the enforced delay when and if in the judgment of the Contract Officer such delay is justified. The Contract Officer's determination shall be final and conclusive upon the parties to this Agreement.

4.4 Term. Unless earlier terminated in accordance with Section 8.9 of this Agreement, this Agreement shall continue in full force and effect until final approval and acceptance of the project by the Contract Officer. Notwithstanding the foregoing, this Agreement shall terminate no later than June 30, 2025, unless the parties mutually agree in writing to extend the term.

5.0 COORDINATION OF WORK

5.1 Representative of Contractor. The following principals of Contractor are hereby designated as being the principals and representatives of Contractor authorized to act in its behalf with respect to the work specified herein and make all decisions in connection therewith:

Wayne Gentry – CEO, Secretary, and Treasurer
Steve Gentry – President

It is expressly understood that the experience, knowledge, capability and reputation of the foregoing principals were a substantial inducement for City to enter into this Agreement. Therefore, the foregoing principals shall be responsible during the term of this Agreement for directing all activities of Contractor and devoting sufficient time to personally supervise the services hereunder. For purposes of this Agreement, the foregoing principals may not be replaced nor may their responsibilities be substantially reduced by Contractor without the express written approval of City.

5.2 Contract Officer. The Contract Officer shall be such person as may be designated by the City Manager or City Engineer of City. It shall be the Contractor's responsibility to assure that the Contract Officer is kept informed of the progress of the performance of the services and the Contractor shall refer any decisions that must be made by City to the Contract Officer. Unless otherwise specified herein, any approval of City required hereunder shall mean the approval of the Contract Officer. The Contract Officer shall have authority to sign all documents on behalf of the City required hereunder to carry out the terms of this Agreement.

5.3 Prohibition Against Assignment. The experience, knowledge, capability and reputation of Contractor, its principals and employees were a substantial inducement for the City to enter into this Agreement. Neither this Agreement nor any interest herein may be transferred, assigned, conveyed, hypothecated or encumbered voluntarily or by operation of law, whether for the benefit of creditors or otherwise, without the prior written approval of City. Transfers restricted hereunder shall include the transfer to any person or group of persons acting in concert of more than twenty five percent (25%) of the present ownership and/or control of Contractor, taking all transfers into account on a cumulative basis. In the event of any such unapproved transfer, including any bankruptcy proceeding, this Agreement shall be void. No approved transfer shall release the Contractor or any surety of Contractor of any liability hereunder without the express consent of City.

5.4 Independent Contractor. Neither the City nor any of its employees shall have any control over the manner, mode or means by which Contractor, its subcontractors, agents or employees, performs the services required herein, except as otherwise set forth herein. City shall have no voice in the selection, discharge, supervision or control of Contractor's employees, subcontractors, servants, representatives or agents, or in fixing their number, compensation or hours of service. Contractor shall perform all services required herein as an independent contractor of City and shall remain at all times as to City a wholly independent contractor with only such obligations as are consistent with that role. Contractor shall not at any time or in any manner represent that it or any of its subcontractors, agents or employees are agents or employees of City. City shall not in any way or for any purpose become or be deemed to be a partner of Contractor in its business or otherwise or a joint venture or a member of any joint enterprise with Contractor.

5.5 Identity of Persons Performing Work. Contractor represents that it employs or will employ at its own expense all personnel required for the satisfactory performance of any and all tasks and services set forth herein. Contractor represents that the tasks and services required herein will be performed by Contractor or under its direct supervision, and that all personnel engaged in such work shall be fully qualified and shall be authorized and permitted under applicable State and local law to perform such tasks and services.

5.6 Utility Relocation. City is responsible for removal, relocation, or protection of existing main or trunkline utilities to the extent such utilities were not identified in the invitation for bids or specifications. City shall reimburse contractor for any costs incurred in locating, repairing damage not caused by contractor and removing or relocating such unidentified utility facilities, including equipment idled during such work. Contractor shall not be assessed liquidated damages for delay arising from the removal or relocation of such unidentified utility facilities.

5.7 Trenches or Excavations. Pursuant to California Public Contract Code Section 7104, in the event the work included in this Agreement requires excavations more than four (4) feet in depth, the following shall apply.

- (a) Contractor shall promptly, and before the following conditions are disturbed, notify City, in writing, of any: (1) material that Contractor believes may be material that is hazardous waste, as defined in Section 25117 of the Health and Safety Code, that is required to be removed to a Class I, Class II, or Class III disposal site in accordance with provisions of existing law; (2) Subsurface or latent physical conditions at the site different from those indicated; or (3) Unknown physical conditions at the site of any unusual nature, different materially from those ordinarily encountered and generally recognized as inherent in work of the character provided for in the contract.
- (b) City shall promptly investigate the conditions, and if it finds that the conditions do materially so differ, or do involve hazardous waste, and cause a decrease or increase in Contractor's cost of, or the time required for, performance of any part of the work shall issue a change order per Section 2.9 of this Agreement.
- (c) That, in the event that a dispute arises between City and Contractor whether the conditions materially differ, or involve hazardous waste, or cause a decrease or increase in Contractor's cost of, or time required for, performance of any part of the work, Contractor shall not be excused from any scheduled completion date provided for by the contract, but shall proceed with all work to be performed under the contract. Contractor shall retain any and all rights provided either by contract or by law, which pertain to the resolution of disputes and protests between the contracting parties.

6.0 INSURANCE, INDEMNIFICATION AND BONDS

6.1 Insurance. The Contractor and all subcontractors, if any, shall procure and maintain, at its sole cost and expense, in a form and content satisfactory to City, during the entire term of this Agreement including any extension thereof, insurance as set forth in Exhibit "B" attached hereto and incorporated herein by this reference.

Conditions:

The insurance of surety companies who provide or issue the policy shall have been admitted to do business in the State of California with a credit rating of A- or better.

This insurance shall not be canceled, limited in scope or coverage or non-renewed until after thirty (30) days prior written notice has been given to the Public Works Director, City of La Habra, 110 E. La Habra Blvd., La Habra, California 90631.

Any insurance maintained by the City of La Habra shall apply in excess of and not combined with insurance provided by this policy.

The City of La Habra, its officers, employees, representatives, attorneys, and volunteers shall be named as additional named insureds.

Prior to commencement of any work under this contract, Contractor shall deliver to the City insurance endorsements confirming the existence of the insurance required by this contract, and including the applicable clauses referenced above.

Such endorsements shall be signed by an authorized representative of the insurance company and shall include the signator's company affiliation and title. Should it be deemed necessary by the City, it shall be Contractor's responsibility to see that the City receives documentation, acceptable to the City, which sustains that the individual signing said endorsements is indeed authorized to do so by the insurance company.

If the Contractor fails to maintain the aforementioned insurance, or secure and maintain the aforementioned endorsement, the City may obtain such insurance, and deduct and retain the amount of the premiums for such insurance from any sums due under the agreement. However, procuring of said insurance by the City is an alternative to other remedies the City may have, and is not the exclusive remedy for failure of Contractor to maintain said insurance or secure said endorsement. In addition to any other remedies the City may have upon Contractor's failure to provide and maintain any insurance or policy endorsements to the extent and within the time herein required, the City shall have the right to order Contractor to stop work hereunder, and/or withhold any payment(s) which became due to Contractor hereunder until Contractor demonstrates compliance with the requirements hereof.

Nothing herein contained shall be construed as limiting in any way the extent to which Contractor may be held responsible for payments of damages to persons or property resulting from Contractor's or its subcontractor's performance of the work covered under this agreement.

Each contract between the Contractor and any subcontractor shall require the subcontractor to maintain the same policies of insurance that the Contractor is required to maintain pursuant to this Section 6.1 and Exhibit "B".

6.2 Certificates of Insurance. Contractor shall provide to City certificates of insurance showing the insurance coverages and required endorsements described above, in a form and content approved by City, prior to performing any services under this Agreement. The certificates of insurance and endorsements shall be attached to this Agreement as Exhibit "C", and are incorporated herein by this reference.

6.3 Indemnification. Contractor shall defend, indemnify, hold free and harmless the City of La Habra, its elected and appointed officials, officers, agents and employees, at Contractor's sole expense, from and against any and all actions, suits, claims, damages to persons or property, losses, costs, penalties, obligations, errors, omissions or liabilities, (herein "claims or liabilities") that may be asserted or claimed by any person, firm or entity arising or alleged to arise out of or in connection with the performance of the work, operations or activities of Contractor, its agents, employees, subcontractors, or invitees, provided for herein, or arising or alleged to arise from the negligent acts or omissions of Contractor hereunder, or arising or alleged to arise from Contractor's performance of or failure to perform any term, provision, covenant or condition of this Agreement.

- (a) Contractor will defend any action or actions filed in connection with any of said claims or liabilities and will pay all costs and expenses, including legal costs and attorneys' fees incurred in connection therewith.
- (b) Contractor will promptly pay any judgment rendered against the City, its officers, agents or employees for any such claims or liabilities arising or alleged to arise out of or in connection with Contractor's (or its agents', employees', subcontractors' or invitees') negligent performance of or failure to perform such work, operations or activities hereunder; and Contractor agrees to save and hold the City, its officers, agents, and employees harmless therefrom.
- (c) In the event the City, its officers, agents or employees is made a party to any action or proceeding filed or prosecuted against Contractor for such damages or other claims arising or alleged to arise out of or in connection with the performance of or failure to perform the work, operation or activities of Contractor hereunder, Contractor shall pay to the City, its officers, agents or employees, any and all costs and expenses incurred by the City, its officers, agents or employees in such action or proceeding, including but not limited to, legal costs and attorneys' fees for counsel selected by City.
- (d) Contractor's duty to defend and indemnify as set out in this Section 6.3 shall include any claims, liabilities, obligations, losses, demands, actions, penalties, suits, costs, expenses or damages or injury to persons or property arising or alleged to arise from, in connection with, as a consequence of or pursuant to any state or federal law or regulation regarding hazardous substances, including but not limited to the Federal Insecticide, Fungicide and Rodenticide Act ("FIFRA"), Comprehensive Environmental Response, Compensation and Liability Act of 1980 ("CERCLA"), Resource Conservation and Recovery Act of 1976 ("RCRA"), the Hazardous and Solid Waste Amendments of 1984, the Hazardous Material Transportation Act, the Toxic Substances control Act, the Clean Air Act, the Clean Water Act, the California Hazardous Substance Account Act, the California Hazardous Waste Control Law or the Porter-Cologne Water Quality Control Act, as any of those statutes may be amended from time to time.

Notwithstanding the foregoing, Contractor shall not be liable for the defense or indemnification of the City for claims, actions, complaints or suits arising out of the sole active negligence or willful misconduct of the City.

The Contractor's indemnification obligations pursuant to this Section 6.3 shall survive the termination of this Agreement. Contractor shall require the same indemnification from all subcontractors.

6.4 Labor and Materials and Performance Bonds. Concurrently with execution of this Agreement, Contractor shall deliver to City a labor and materials bond and a performance bond each in the sum of the amount of this Agreement, in the forms provided by the City Clerk, which secures the faithful performance of this Agreement. The bonds shall contain the original notarized signature of an authorized officer of the surety and affixed thereto shall be a certified and current copy of his power of attorney. The bonds shall be unconditional and remain in force during the entire term of the Agreement and shall be null and void only if the Contractor promptly and faithfully performs all terms and conditions of this Agreement.

6.5 Sufficiency of Insurer or Surety. Insurance required by this Agreement shall be satisfactory only if issued by companies qualified to do business in California, rated "A" or better in the most recent edition of Best Rating Guide, The Key Rating Guide or in the Federal Register, and only if they are of a financial category Class VII or better, unless such requirements are waived by the Risk Manager of the City due to unique circumstances.

6.6 Substitution of Securities. Pursuant to California Public Contract Code Section 22300, substitution of eligible equivalent securities for any monies withheld to ensure performance under the contract for the work to be performed will be permitted at the request and expense of the successful bidder.

7.0 RECORDS AND REPORTS

7.1 Reports. Contractor shall periodically prepare and submit to the Contract Officer such reports concerning the performance of the services required by this Agreement as the Contract Officer shall require. Contractor hereby acknowledges that the City is greatly concerned about the cost of work and services to be performed pursuant to this Agreement. For this reason, Contractor agrees that if Contractor becomes aware of any facts, circumstances, techniques, or events that may or will materially increase or decrease the cost of the work or services contemplated herein or, if Contractor is providing design services, the cost of the project being designed, Contractor shall promptly notify the Contract Officer of said fact, circumstance, technique or event and the estimated increased or decreased cost related thereto and, if Contractor is providing design services, the estimated increased or decreased cost estimate for the project being designed.

7.2 Records. Contractor shall keep, and require subcontractors to keep, such books and records (including but not limited to payroll records as required herein) as shall be necessary to perform the services required by this Agreement and enable the Contract Officer to evaluate the performance of such services. The Contract Officer shall have full and free access to such books and records at all times during normal business hours of City, including the right to inspect, copy, audit and make records and transcripts from such records. Such records shall be maintained for a period of three (3) years following completion of the services hereunder, and the City shall have access to such records in the event any audit is required.

7.3 Ownership of Documents. All drawings, specifications, reports, records, documents and other materials prepared by Contractor, its employees, subcontractors and agents in the performance of this Agreement shall be the property of City and shall be delivered to City upon request of the Contract Officer or upon the termination of this Agreement, and Contractor shall have no claim for further employment or additional compensation as a result of the exercise by City of its full rights of ownership of the documents and materials hereunder. Contractor may retain copies of such documents for its own use. Contractor shall have an unrestricted right to use the concepts embodied therein. All subcontractors shall

provide for assignment to City of any documents or materials prepared by them, and in the event Contractor fails to secure such assignment, Contractor shall indemnify City for all damages resulting therefrom.

7.4 Public Records Act Disclosure. Contractor has been advised and is aware that this Agreement and all reports, documents, information and data, including, but not limited to, computer tapes, discs or files furnished or prepared by Contractor, or any of its subcontractors, pursuant to this Agreement and provided to City may be subject to public disclosure as required by the California Public Records Act (California Government Code Section 7920.000 *et seq.*). Exceptions to public disclosure may be those documents or information that qualify as trade secrets, as that term is defined in the California Government Code Section 7924.510, and of which Contractor informs City of such trade secret. The City will endeavor to maintain as confidential all information obtained by it that is designated as a trade secret. The City shall not, in any way, be liable or responsible for the disclosure of any trade secret including, without limitation, those records so marked if disclosure is deemed to be required by law or by order of the Court.

8.0 GENERAL PROVISIONS

8.1 Governing Law. This Agreement shall be construed and interpreted both as to validity and to performance of the parties in accordance with the laws of the State of California. Legal actions concerning any dispute, claim or matter arising out of or in relation to this Agreement shall be instituted in the Superior Court of the County of Orange, State of California, or any other appropriate court in such county, and Contractor covenants and agrees to submit to the personal jurisdiction of such court in the event of such action.

8.2 Representatives. The City Manager or his or her designee shall be the representative of City for purposes of this Agreement and may issue all consents, approvals, directives and agreements on behalf of the City, called for by this Agreement, except as otherwise expressly provided in this Agreement.

The Principal set forth in Section 5.1 above shall be the representative for Contractor for purposes of this Agreement, and shall be authorized to issue all consents, approvals, directives and agreements on behalf of Contractor called for by this Agreement, except as otherwise expressly provided in this Agreement.

8.3 Disputes. In the event either party fails to perform its obligations hereunder, the nondefaulting party shall provide the defaulting party written notice of such default. The defaulting party shall have ten (10) days to cure the default; provided that, if the default is not reasonably susceptible to being cured within said ten (10) day period, the defaulting party shall have a reasonable time to cure the default, not to exceed a maximum of thirty (30) days, so long as the defaulting party commences to cure such default within ten (10) days of service of such notice and diligently prosecutes the cure to completion; provided further that if the default is an immediate danger to the health, safety and general welfare, the defaulting party shall take such immediate action as may be necessary. Notwithstanding the foregoing, the nondefaulting party may, in its sole and absolute discretion, grant a longer cure period. Should the defaulting party fail to cure the default within the time period provided in this Section, the nondefaulting party shall have the right, in addition to any other rights the nondefaulting party may have at law or in equity, to terminate this Agreement. Compliance with the provisions of this Section 8.3 shall be a condition precedent to bringing any legal action, and such compliance shall not be a waiver of any party's right to take legal action in the event that the dispute is not cured.

8.4 Retention of Funds. Progress payments shall be made in accordance with the provisions of Section 3.2 of this Agreement. In accordance with said section, City shall pay Contractor a sum based upon ninety-five percent (95%) of the contract price apportionment of the labor and materials

Attn.: Albert Mendoza

To Contractor: Wayne Gentry
Gentry Brothers Inc
384 Live Oak Ave.
Irwindale, CA 91706

8.11 Non-liability of City Officers and Employees. No officer or employee of the City shall be personally liable to the Contractor, or any successor in interest, in the event of any default or breach by the City or for any amount which may become due to the Contractor or to its successor, or for breach of any obligation of the terms of this Agreement.

8.12 Conflict of Interest. The Contractor warrants that it has not paid or given and will not pay or give any third party any money or other consideration for obtaining this Agreement.

Contractor and its officers, employees, associates and subcontractors, if any, will comply with all conflict of interest statutes of the State of California applicable to Contractor's services under this agreement, including, but not limited to, the Political Reform Act (Government Code Sections 81000, *et seq.*) and Government Code Section 1090. During the term of this Agreement, Contractor and its officers, employees, associates and subcontractor shall not, without the prior written approval of the City Representative, perform work for another person or entity for whom Contractor is not currently performing work that would require Contractor or one of its officers, employees, associates or subcontractors to abstain from a decision under this Agreement pursuant to a conflict of interest statute.

8.13 Covenant Against Discrimination. Contractor covenants that, by and for itself, its heirs, executors, assigns, and all persons claiming under or through them, that there shall be no discrimination against or segregation of, any person or group of persons on account of race, color, creed, religion, sex, marital status, national origin, or ancestry in the performance of this Agreement. To the extent required by law, contractor shall take affirmative action to insure that applicants are employed and that employees are treated during employment without regard to their race, color, creed, religion, sex, marital status, national origin, or ancestry.

8.14 Interpretation. The terms of this Agreement shall be construed in accordance with the meaning of the language used and shall not be construed for or against either party by reason of the authorship of this Agreement or any other rule of construction which might otherwise apply.

8.15 Severability. In the event that any one or more of the phrases, sentences, clauses, paragraphs, or sections contained in this Agreement shall be declared invalid or unenforceable by a valid judgment or decree of a court of competent jurisdiction, such invalidity or unenforceability shall not affect any of the remaining phrases, sentences, clauses, paragraphs, or sections of this Agreement which are hereby declared as severable and shall be interpreted to carry out the intent of the parties hereunder unless the invalid provision is so material that its invalidity deprives either party of the basic benefit of their bargain or renders this Agreement meaningless.

8.16 [reserved]

8.17 Unfair Business Practices Claims. In entering into a public works contract or a subcontract to supply goods, services or materials pursuant to a public works contract, the contractor or

subcontractor offers and agrees to assign to the awarding body all rights, title, and interest in and to all causes of action it may have under Section 4 of the Clayton Act (15 U.S.C. Sec. 15) or under the Cartwright Act (Chapter 2, (commencing with Section 16700) of Part 2 of Division 7 of the Business and Professions Code), arising from purchases of goods, services or materials pursuant to the public works contract or the subcontract. This assignment shall be made and become effective at the time the awarding body renders final payment to the contractor without further acknowledgment by the parties. (Sec. 7103.5, California Public Contract Code).

8.18 Corporate Authority. The persons executing this Agreement on behalf of the parties hereto warrant that (i) such party is duly organized and existing, (ii) they are duly authorized to execute and deliver this Agreement on behalf of said party, (iii) by so executing this Agreement, such party is formally bound to the provisions of this Agreement, and (iv) the entering into this Agreement does not violate any provision of any other Agreement to which said party is bound.

8.19 PERS Eligibility Indemnification. In the event that Contractor or any employee, agent, or subcontractor of Contractor providing services under this Agreement claims or is determined by a court of competent jurisdiction or the California Public Employees Retirement System (PERS) to be eligible for enrollment in PERS as an employee of the City, Contractor shall indemnify, defend, and hold harmless City for the payment of any employee and/or employer contributions for PERS benefits on behalf of Contractor or its employees, agents, or subcontractors, as well as for the payment of any penalties and interest on such contributions, which would otherwise be the responsibility of City.

Notwithstanding any other agency, state or federal policy, rule, regulation, law or ordinance to the contrary, Contractor and any of its employees, agents, and subcontractors providing service under this Agreement shall not qualify for or become entitled to, and hereby agree to waive any claims to, any compensation, benefit, or any incident of employment by City, including but not limited to eligibility to enroll in PERS as an employee of City and entitlement to any contribution to be paid by City for employer contribution and/or employee contributions for PERS benefits.

8.20 Cooperation. In the event any claim or action is brought against City relating to Contractor's performance or services rendered under this Agreement, Contractor shall render any reasonable assistance and cooperation which City might require.

8.21 Legal Responsibilities. The Contractor shall keep itself informed of City, State, and Federal laws, ordinances and regulations, which may in any manner affect the performance of its services pursuant to this Agreement. The Contractor shall at all times observe and comply with all such laws, ordinances and regulations. Neither the City, nor its officers, agents, or employees shall be liable at law or in equity as a result of the Contractor's failure to comply with this section.

8.22 Termination for Convenience. The City may terminate this Agreement without cause for convenience of the City upon giving contractor 30 days prior written notice of termination of the Agreement. Upon receipt of the notice of termination the Contractor shall cease all further work pursuant to the Agreement. Upon such termination by the City the Contractor shall not be entitled to any other remedies, claims, actions, profits, or damages except as provided in this paragraph. Upon the receipt of such notice of termination Contractor shall be entitled to the following compensation:

1. The contract value of the work completed to and including the date of receipt of the notice of termination, less the amount of progress payments received by contractor.

2. Actual move-off costs including labor, rental fees, equipment transportation costs, the costs of maintaining on-site construction office for supervising the mover-off.

3. The cost of materials custom made for this Agreement which cannot be used by the Contractor in the normal course of his business, and which have not been paid for by City in progress payments.

4. All costs shall not include any markups as might otherwise be allowed by any plans or specifications which were a part of the Agreement.

The provisions of this paragraph shall supersede any other provision of the Agreement or any provision of any plans, specification, addendums or other documents which are or may become a part of this Agreement. City and Contractor agree that the provisions of this paragraph are a substantive part of the consideration for this Agreement.

8.23 Responsibility for Errors. Contractor shall be responsible for its work and results under this Agreement. Contractor, when requested, shall furnish clarification and/or explanation as may be required by the City's representative, regarding any services rendered under this Agreement at no additional cost to City. In the event that an error or omission attributable to Contractor occurs, then Contractor shall, at no cost to City, provide all necessary design drawings, estimates and other Contractor professional services necessary to rectify and correct the matter to the sole satisfaction of City and to participate in any meeting required with regard to the correction.

8.24 Order of Precedence. In the event of an inconsistency in this Agreement and any of the attached Exhibits, the terms set forth in this Agreement shall prevail. If, and to the extent this Agreement incorporates by reference any provision of any document, such provision shall be deemed a part of this Agreement. Nevertheless, if there is any conflict among the terms and conditions of this Agreement and those of any such provision or provisions so incorporated by reference, this Agreement shall govern over the document referenced.

8.25 Costs. Each party shall bear its own costs and fees incurred in the preparation and negotiation of this Agreement and in the performance of its obligations hereunder except as expressly provided herein.

8.26 No Third Party Beneficiary Rights. This Agreement is entered into for the sole benefit of City and Contractor and no other parties are intended to be direct or incidental beneficiaries of this Agreement and no third party shall have any right in, under or to this Agreement.

8.27 Headings. Paragraphs and subparagraph headings contained in this Agreement are included solely for convenience and are not intended to modify, explain or to be a full or accurate description of the content thereof and shall not in any way affect the meaning or interpretation of this Agreement.

8.28 Construction. The parties have participated jointly in the negotiation and drafting of this Agreement. In the event an ambiguity or question of intent or interpretation arises with respect to this Agreement, this Agreement shall be construed as if drafted jointly by the parties and in accordance with its fair meaning. There shall be no presumption or burden of proof favoring or disfavoring any party by virtue of the authorship of any of the provisions of this Agreement.

8.29 Counterparts. This Agreement may be executed in one or more counterparts, each of which

City Project No. 2-R-22.

shall be deemed an original. All counterparts shall be construed together and shall constitute one agreement.

8.30 Funding Source Conditions – Contractor’s Obligation. Contractor acknowledges that the City may be paying for the Project by using funds it receives or will receive from various funding sources in the form of grants and/or subsidies, and the like under certain terms and conditions. Contractor acknowledges and agrees that any failure of the Contractor and/or its subcontractors to perform its obligations under the Contract, including, but not limited to, timely submitting accurate reports and records, that in any way results in the City not meeting the terms and conditions placed on the funds by the funding source, or forfeiting its entitlement to or, otherwise, not receiving, the funds, then the Contractor shall be liable to pay the City for the funds not granted to the City on the Project.

8.31 Entire Agreement. This Agreement constitutes the entire agreement between the parties with respect to any matter referenced herein and supersedes any and all other prior writings and oral negotiations. This Agreement may be modified only in writing, and signed by the parties in interest at the time of such modification. The terms of this Agreement shall prevail over any inconsistent provision in any other contract document appurtenant hereto, including exhibits to this Agreement.

City Project No. 2-R-22.

IN WITNESS WHEREOF, the parties have executed and entered into this Agreement as of the date first written above.

CITY OF LA HABRA,
A municipal corporation

Jim Sadro, City Manager

Date: _____

CONTRACTOR

Signature

Date: 6/4/24

WAYNE GENTRY SEC. TRES
Name and Title

95-3534970
Social Security or Taxpayer ID Number

ATTEST:

Rhonda J. Barone, City Clerk

Date: _____

APPROVED AS TO FORM:

Richard D. Jones, City Attorney

Date: _____

(Use of City Bond Form is Required)

**LABOR AND MATERIAL PAYMENT BOND
PUBLIC WORK (CALIFORNIA)**

KNOW ALL MEN BY THESE PRESENT:

WHEREAS, _____, as Principal, has entered into a contract dated _____, with the City of La Habra (Obligee) referred to and made a part hereof to perform the following work, to wit: _____ and all appurtenant work in accordance with PROJECT NO. _____, which requires Principal to file this bond to secure claims made in relation to the project.

NOW THEREFORE, we, _____, as Principal, and _____, a corporation organized under the laws of _____ and duly authorized to transact business in the State of California, as Surety, are held firmly bound unto the City of La Habra, as Obligee, and all sub-contractors, laborers, material persons and other persons employed in the performance of the referenced agreement, in the sum of _____ Dollars (\$ _____ .00), lawful money of the United States of America, for the payment whereof well and truly to be made the Principal and Surety bind themselves, their heirs, executors, administrators, successors, and assigns, jointly and severally, firmly by these presents.

If the above bounden PRINCIPAL, his or its heirs, executors, administrators, successors, assigns, or any of his or its sub-contractors, fails to pay for any materials, provisions, provender, or other supplies, or teams, implements or machinery, used in, upon, for or about the performance of the work contracted to be done, or for any work or labor to persons named in Section 9100 or the Civil Code, thereon of any kind, or for amounts due under the Unemployment Insurance Code with respect to such work or labor deducted, withheld and paid over to the Employment Development Department from the wages of employees of the contractor and sub-contractors pursuant to Section 13020 of the Unemployment Insurance Code, that the SURETY on this bond will pay the same, in an amount not exceeding the sum specified in this bond, AND ALSO, in case suit is brought upon this bond, a reasonable attorney's fee, which shall be awarded by the court to the prevailing party in said suit, said attorney's fee to be taxed as costs in said suit and to be included in the judgment herein rendered.

As part of the obligation secured hereby, the SURETY shall not be exonerated or released from the obligation of the bond by any change, alteration, or modification in or of any contract, plans, specifications, or agreement pertaining or relating to any scheme or work of improvement or pertaining or relating to the furnishing of labor, materials, or equipment therefor, nor by any change or modification of any terms of payment or extension of the time for any payment pertaining or relating to any scheme of work of improvement, nor by any rescission or attempted rescission of the contract, agreement or bond, nor by any conditions precedent or subsequent in the bond attempting to limit the right of recovery of claimants otherwise entitled to recover under

any such contract or agreement, or under the bond, nor, where the bond is given for the benefit of claimants, by any fraud practiced by any person other than the claimant seeking to recover on the bond.

This bond shall inure to the benefit of any and all persons, companies and corporations entitled to file claims under the Civil Code so as to give them a right of action in a suit on this bond.

This bond is executed for the purpose of complying with the laws of the State of California and shall inure to the benefit of any of the persons named in Section 9100 of the Civil Code of the State of California.

IN WITNESS THEREOF, we have hereunto set our hands and seals this _____ day of _____, 20__.

(Corporate Seal)

Principal

By _____

Title _____

(Corporate Seal)

Principal

By _____

Title _____

APPROVED AS TO FORM:
/s/ Richard D. Jones
City Attorney

FAITHFUL PERFORMANCE BOND

KNOW ALL MEN BY THESE PRESENTS:

That we, _____

_____ hereinafter referred to as

“Contractor”, as principal, and _____

_____ as surety, are held and firmly

bound unto City of La Habra in the sum of _____

_____ Lawful money of the United States of America for the payment of which sum well and truly to be made we bind ourselves jointly and severally, firmly by these presents.

The condition of the foregoing obligation is such that WHEREAS, said Contract has been awarded and is about to enter into the annexed contract with City of La Habra for construction of Street Improvements as specifically set forth in the documents entitled:

**MONTE VISTA STREET REHABILITATION PROJECT
CITY PROJECT NO. 2-R-22**

and is required under the terms of the Contract to give this bond in connection with the execution of said contract.

NOW, THEREFORE, if the said Contractor shall well and truly do and perform all of the covenants and obligations of said contract on his part to be done and performed at the times and in the manner specified herein, then this obligation shall be null and void, otherwise it shall be and remain in full force and effect.

PROVIDED, that any alterations in the work to be done or the materials to be furnished which may be made pursuant to the terms of said Contract shall not in any way release either the Contractor or the surety thereunder nor shall any extensions of time granted under the provisions of said Contract release either the Contractor or the surety, and notice of such alterations or extensions of the Contract is hereby waived by the surety.

WITNESS our hands this _____ day of _____, 2024.

Contractor

BY: _____

(Seal)

Title

APPROVED:

Surety

BY: _____

(Seal)

Mailing Address of Surety:

Telephone Number of Surety

(Use of City form is required)

SUPPLEMENTAL INFORMATION TO BE COMPLETED BY PRINCIPAL

If an individual, so state. If a firm or co-partnership, state the firm and give the names of all individual co-partners composing the partnership. If a Corporation, state legal name of corporation; state also the names of the president, secretary, treasurer and manager thereof.

Business Address: _____

Telephone Number: _____

Date: _____

Print Name: _____
Principal

Signature: _____
Title

(Use of City form
is required)

TAX IDENTIFICATION NUMBER

The Tax Equity and Fiscal Responsibility Act of 1982 requires the payer (City of La Habra) to report to the Internal Revenue Service taxable payments to payees.

You (as a payee) are required by law to provide us with your Taxpayer Identification Number (if an individual or partnership, your Social Security Number). If you do not provide us with your correct identification number, you may be subject to a penalty imposed by the Internal Revenue Service. The payments subject to withholdings may include, but are not limited to, interest, dividends, or other payments the City of La Habra made to you. Other payments may include rents, royalties, commissions and fees for service of non-employees.

If you are exempt from income tax, we are still required, by law, to maintain a Tax Identification Number on file. **PLEASE PROVIDE YOUR TAX IDENTIFICATION NUMBER next to the appropriate listing below, sign, date and return to:**

CITY OF LA HABRA FINANCE DEPARTMENT
110 E. La Habra Blvd
La Habra, CA 90631

Exempt: Yes___ No___ Telephone () _____

CORPORATION: _____

U.S.A. OR ANY AGENCIES THEREOF: _____

IRS CODE #501 TAX-EXEMPT ORGANIZATION: _____

A NON-COMMISSIONED CITY OF LA HABRA EMPLOYEE: _____

SOLE PROPRIETOR: _____

A PARTNERSHIP: _____

OTHER: _____ (Explain)

Signature/Title: _____ Date: _____

BID GUARANTEE

**TO THE CITY OF LA HABRA
MONTE VISTA STREET REHABILITATION PROJECT, CITY PROJECT NO. 2-R-22**

As a material inducement to the City to award the contract for Project No. 2-R-22 to _____, the undersigned (“Guarantor”) has agreed to enter into this guarantee. The Guarantor hereby unconditionally guarantees to the fullest extent allowed by law the following work included in this project: _____ (“the work”).

Guarantor guarantees that the materials and equipment used by itself and its subcontractors will be free from defects and that the work will conform to the plans and specifications. Should any of the materials or equipment prove defective or should the work as a whole, or any part thereof, prove defective for any reason whatsoever (except due to intentional torts by the City), or should the work as a whole or any part thereof fail to operate properly or fail to comply with the plans and specifications, Guarantor will, at the City’s sole election: 1) reimburse the City, upon written demand, for all of the City’s expenses incurred replacing or restoring any such equipment or materials, including the cost of any work necessary to make such replacement or repairs; or 2) replace any such defective material or equipment and repair said work completely, all without any cost to the City. Guarantor further guarantees that any such repair work will conform to the plans and specifications for the project. This guarantee will remain in effect for five years from the date on which the contracted for work is accepted for use by the City.

Guarantor understands and agrees that the City shall have the unqualified option to make any replacements or repairs itself or to have such replacement, repair, performed by the undersigned. The City shall have no obligation to consult with Guarantor before the City proceeds to perform any repair, replacement, or work itself. If the City elects to have Guarantor perform said repair, replacement, or work, Guarantor agrees that the repair, replacement, or work shall be performed within 15 days after receipt of a written demand from the City.

If the City elects to perform the replacement, repairs itself, Guarantor agrees to make reimbursement payment within 15 days after receipt of a written demand for payment from the City.

If the Guarantor fails or refuses to comply with this guarantee, the City shall be entitled to all costs and expenses, including attorneys and expert fees, reasonably incurred by reason of Guarantor’s failure or refusal.

Guarantor _____ Date: _____

Contractor: _____ By: _____

Title: _____

STATEMENT OF NON COLLUSION BY CONTRACTOR

The undersigned who submits herewith to the City of La Habra a bid or proposal does hereby certify:

- a. That all statements of fact in such bid or proposal are true;
- b. That such bid or proposal was not made in the interest of or on behalf of any undisclosed person, partnership, company, association, organization or corporation;
- c. That such bid or proposal is genuine and not collusive or sham;
- d. That said bidder has not, directly or indirectly by agreement, communication or conference with anyone, attempted to induce action prejudicial to the interest of the City of La Habra or of any other bidder or anyone else interested in the proposed procurement;
- e. Did not, directly or indirectly, collude, conspire, connive or agree with anyone else that said bidder or anyone else would submit a false or sham bid or proposal, or that anyone should refrain from bidding or withdraw his bid or proposal;
- f. Did not in any manner, directly or indirectly seek by agreement, communication or conference with anyone to raise or fix the bid or proposal price of said bidder or of anyone else, or to raise or fix any overhead, profit or cost element of his bid or proposal price, or that of anyone else;
- g. Did not, directly or indirectly, submit his bid or proposal price or any breakdown thereof, or the contents thereof, or divulge information or data relative thereto, to any corporation, partnership, company, association, organization, bid depository, or to any member agent thereof, or to any individual or group of individuals, except to the City of La Habra, or to any person or persons who have a partnership or their financial interest with said bidder in his business.
- h. Did not provide, directly or indirectly to any officer or employee of the City of La Habra any gratuity, entertainment, meals, or anything of value, whatsoever, which could be objectively construed as intending to invoke any form of reciprocation or favorable treatment.
- i. That no officer or principal of the undersigned firm is related to any officer or employee of the city by blood or marriage within the third degree or is employed, either full or part time, by the City of La Habra either currently or within the last two (2) years.
- j. That no officer or principal of the undersigned firm nor any subcontractor to be engaged by the principal has been convicted by a court of competent jurisdiction of any charge of fraud, bribery, collusion, conspiracy or any other act in violation of any state or federal antitrust law in connection with the bidding upon award of, or performance of, any public work contract, with any public entity, within the last three years.

I certify, under penalty of perjury under the laws of the State of California, that the foregoing is true and correct and that this certification was executed:

On _____ at _____ California.

Firm _____

(Signature)

Street _____

(Print Name & Title)

City _____ State _____ Zip _____

CERTIFICATION OF COMPLIANCE

AFFIRMATIVE ACTION REQUIREMENTS

EQUAL EMPLOYMENT OPPORTUNITY

For

**MONTE VISTA STREET REHABILITATION PROJECT FY 22-23
CITY PROJECT NO. 2-R-22**

_____ Certifies that:

(Contractor)

It has adopted and approved affirmative action plan in compliance with Title VII of the Civil Rights Act and the Equal Employment Opportunity Act of 1972 and agrees to submit a copy of that plan to the Assistant to the City Manager/Personnel of the City of La Habra for inspection prior to the award of contract.

Signed: _____

By: _____

Title: _____

Date: _____

City Project No. 2-R-22.

EXHIBIT A
SCOPE OF SERVICES

PROPOSAL

City of La Habra
Civic Center
110 E. La Habra Blvd.
La Habra, California 90631

Gentlemen:

The undersigned hereby proposes to perform all work for which a contract may be awarded him and to furnish any and all plant, labor, services, materials, tools, equipment, supplies, transportation, utilities, and all other items and facilities necessary therefor as provided in the Contract Documents, and to do everything required therein for the project specifically set forth in documents entitled:

MONTE VISTA STREET REHABILITATION PROJECT FISCAL YEAR 2022-2023 CITY PROJECT NO. 2-R-22

together with appurtenances thereto, all as set forth on the drawing and in the specifications and other Contract Documents; and, he further proposes and agrees that if this Proposal is accepted he will contract in the form and manner stipulated to perform all the work called for by drawings, specifications and other Contract Documents and to complete all such work in strict conformity therewith within the time limits set forth therein, and that he will accept as full payment therefor the prices set forth in the Bid Schedule forming a part hereof.

A *(Cashier's Check) *(Certified Check) *(Bid Bond) properly made payable to City of La Habra hereinafter designated as the Owner for the sum of EIGHT HUNDRED FIFTY EIGHT THOUSAND NINE HUNDREN FORTY DOLLARS dollars (\$ 858,940.00), which amount is not less than ten percent (10%) of the total amount of this bid, is attached hereto and is given as a guarantee that the undersigned will execute the Agreement and furnish the required bonds if awarded the Contract; and, in case of failure to do so within the time provided the proceeds of said check shall be forfeited to the *Owner/Sureties Liability to the Owner for forfeiture of the face amount of the Bond shall be considered as established.

(*) Delete inapplicable word or phrase.

It is understood and agreed that:

1. The undersigned has carefully examined all the Contract Documents which will form a part of the Contract;
2. The undersigned has, by investigation of the site of the work and otherwise, satisfied himself as to the nature and location of the work and has fully informed himself as to all conditions and matters which can in any way affect the work or the cost thereof;
3. The undersigned fully understands the scope of the work and has checked carefully all words and figures inserted in this proposal and he further understands that the Owner will in no way be responsible for any errors or omissions in the preparation of this proposal;

4. The undersigned will execute the Agreement and furnish the required Performance and Payment Bonds and proof of insurance coverage, within ten (10) days (not including Saturdays, Sundays and holidays) after notice to him of acceptance of his bid by the Owner; and further, that this bid may not be withdrawn for a period of sixty (60) days after the date set for the opening thereof, unless otherwise required by law. If any bidder shall withdraw his bid within said period, the Contractor shall be liable under the provisions of the Bid Security or the Contract and his surety shall be liable under the Bid Bond, as the case may be;
5. The undersigned hereby certifies that this proposal is genuine and not sham or collusive or made in the interest or in behalf of any person not herein named and the undersigned has not directly or indirectly induced or solicited any other bidder to put in a sham bid or any other person, firm or corporation to refrain from bidding; the undersigned has not in any manner sought by collusion to secure for himself an advantage over any other bidder;
6. In conformance with current statutory requirements of Section 1860, et seq., of the Labor Code of the State of California, the undersigned confirms the following as his certification:

I am aware of the provisions of Section 3700 of the Labor Code which requires every employer to be insured against liability of worker's compensation or to undertake in accordance with the provisions before commencing the performance of the work of this contract.

NOW, in compliance with the Notice Inviting Bids and all the provisions hereinbefore stipulated, the undersigned, with full cognizance thereof, hereby proposes to perform the entire work for the prices set forth in the attached Bid Schedule upon which award of the Contract is made.

Date: 4-23, 2024

Bidder GENTRY BROTHERS INC

By 

Title SEC. TREAS

Bidder's Post Office Address: Gentry Brothers Inc
384 Live Oak Ave
Irwindale CA 91706

Corporation organized under
the laws of the State of CA

Names and addresses of all owners
of the firm or names and titles of
all officers of the corporation:

WAYNE GENTLY CEO, SEC, PRES
STEVE GENTLY PRES

(corporate seal)

BIDDER'S INFORMATION

Contractor's License No. 397682 Expiration Date 12-25

Classification of Contractor's License No. A

Contractor GENTRY BROTHERS INC
(name of firm)

By  SEC TAES
(signature) (title)

Business Address: Gentry Brothers Inc
384 Live Oak Ave
Irwindale CA 91706

Phone (626) 357-9631

I/We certify that the information provided above is complete and true to the best of my/our knowledge.

GENTRY BROTHERS INC 4-23-24
Contractor Date

Contractor's DIR Public Works Registration No. 1000002240

BID SCHEDULE**MONTE VISTA STREET REHABILITATION PROJECT**
FISCAL YEAR 2022-2023, CITY PROJECT NO. 2-R-22

| ITEM | DESCRIPTION | QUANTITY | UNIT | UNIT PRICE | AMOUNT |
|------|--|----------|------|------------|-------------|
| 1 | MOBILIZATION/ DEMOLITION (Not to Exceed Five Percent (5%) of the total bid amount) | 1 | LS | 42,000.- | \$42,000.- |
| 2 | TRAFFIC CONTROL, SAFETY, AND CLEANUP (Not to Exceed Five Percent (5%) of the total bid amount) | 1 | LS | 42,000.- | \$42,000.- |
| 3 | CORNER RECORDS, CONSTRUCTION STAKING AND MONUMENT PERPETUATION | 1 | LS | 15,000.- | \$15,000.- |
| 4 | STORM WATER BEST MANAGEMENT PRACTICES (BMPs) | 1 | LS | 15,000.- | \$15,000.- |
| 5 | TRAFFIC SIGNING, STRIPING, PAVEMENT MARKERS AND PAVEMENT MARKINGS | 1 | LS | 15,000.- | \$15,000.- |
| 6 | UNCLASSIFIED EXCAVATION AND DISPOSAL | 510 | CY | 70.- | \$35,700.- |
| 7 | COLD MILL EXISTING AC PAVEMENT TO 2" DEPTH | 77,600 | SF | 0.70 | \$54,320.- |
| 8 | CMB (CRUSHED MISCELLANEOUS BASE) AS NEEDED | 470 | TON | 22.- | \$10,340.- |
| 9 | INSTALL 4" THICK ASPHALT CONCRETE BASE COURSE (B PG 64-10) | 690 | TON | 120.- | \$82,800.- |
| 10 | INSTALL 2" THICK ASPHALT RUBBER HOT MIX (ARHM) OVERLAY (ARHM-GG-C PG 64-16). | 1,250 | TON | 132.- | \$165,000.- |
| 11 | REMOVE EXISTING, GRADE AND INSTALL 4" THICK ASPHALT CONCRETE PAVEMENT (C2 PG 64-10) | 20 | TON | 111.50 | \$2,230.- |

| | | | | | |
|----|--|-------|----|----------|------------|
| 12 | SAWCUT AND REMOVE EXISTING SIDEWALK. CONSTRUCT NEW 4" THICK PCC SIDEWALK OVER COMPACTED NATIVE SOIL | 3,440 | SF | 16.- | \$55,040.- |
| 13 | SAWCUT AND REMOVE EXISTING CROSS-GUTTER AND SPANDREL. CONSTRUCT NEW 8" PCC GROSS-GUTTER AND SPANDREL PER LA HABRA STD. DETAIL R-6 OVER 6" CMB, 1' WIDE AC SLOT PATCH, TYPE C2 PG 64-10 | 950 | SF | 22.- | \$20,900.- |
| 14 | SAWCUT AND REMOVE EXISTING DRIVEWAY APPROACH. CONSTRUCT NEW 6" PCC DRIVEWAY APPROACH PER SPPWC 110-2. | 810 | SF | 18.- | \$14,580.- |
| 15 | SAWCUT AND REMOVE EXISTING ALLEY APPROACH. CONSTRUCT NEW 8" PCC ALLEY APPROACH PER SPPWC 130-3 | 340 | SF | 22.- | \$7,480.- |
| 16 | SAWCUT AND REMOVE EXISTING LOCAL DEPRESSION PER SPPWC STANDARD PLAN 313-4 | 200 | SF | 22.- | \$4,400.- |
| 17 | REMOVE AND REPLACE VARIABLE HEIGHT PCC CURB & GUTTER OVER 6" CMB PER LA HABRA STANDARD DETAIL R-13, TYPE A2-8, INCLUDES 1' SLOT CUT AND PATCH, TYPE C2 PG 64-10. | 550 | LF | 160.- | \$88,000.- |
| 18 | SAWCUT AND REMOVE EXISTING CURB RAMP. CONSTRUCT NEW 4" PCC CURB RAMP OVER COMPACTED NATIVE SOIL PER CALTRANS STANDARD PLAN RSP A88A, AS NOTED ON PLAN OR DIRECTED BY CITY IN FIELD, 1' WIDE AC SLOT PATCH. | 12 | EA | 11,500.- | \$11,500.- |
| 19 | CONSTRUCT PCC RETAINING CURB | 80 | LF | 35.- | \$2,800.- |

| | | | | | |
|----|--|----|----|---------|------------|
| 20 | ADJUST MANHOLE TO GRADE | 27 | EA | 1,000.- | \$27,000.- |
| 21 | ADJUST VALVE FRAME AND COVER TO GRADE | 18 | EA | 125.- | \$2,250.- |
| 22 | REPLACE METER BOX AND LID | 15 | EA | 500.- | \$7,500.- |
| 23 | INSTALL 6-FOOT TRAFFIC SIGNAL LOOP DETECTORS | 4 | EA | 1,800.- | \$7,200.- |
| 24 | CONSTRUCT HEADER BOARD WITH STAKES | 60 | LF | 60.- | \$3,600.- |
| 25 | RELOCATE MAILBOX | 2 | EA | 400.- | \$800.- |

TOTAL BID PRICE FOR BID SCHEDULE IN FIGURES: \$ 858,940.00

TOTAL BID PRICE FOR BID SCHEDULE IN WORDS: EIGHT HUNDRED ~~FIVE~~ FIFTY

EIGHT THOUSAND NINE HUNDRED FORTY DOLLARS

PROPOSAL

Note: Excavation is included in the various bid items.

Note: The TOTAL BID PRICE shall be used as the basis of bid in determining the low bid for this project.

GENTRY BROTHERS INC

CONTRACTOR

BY

TITLE

DATE

[Handwritten Signature]

SEL, TRES

4.23.24

ACKNOWLEDGEMENT OF ADDENDA RECEIVED

The Bidder shall acknowledge the receipt of addenda by placing an "X" by each addendum received.

- Addendum No. 1 _____
- Addendum No. 2 _____
- Addendum No. 3 _____
- Addendum No. 4 _____
- Addendum No. 5 _____
- Addendum No. 6 _____
- Addendum No. 7 _____
- Addendum No. 8 _____

If an addendum or addenda have been issued by the CITY and is not noted above as being received by the Bidder, the Bid Proposal may be rejected.

REFERENCES

[Work similar in scope magnitude and degree of difficulty completed by Contractor within the past three (3) years.]

1. Name (Firm/Agency): ATTACHED
Address: _____
Contact Person: _____ Telephone No. _____
Title of Project: _____
Project Location: _____
Date of Completion: _____ Contract Amount: \$ _____
2. Name (Firm/Agency): _____
Address: _____
Contact Person: _____ Telephone No. _____
Title of Project: _____
Project Location: _____
Date of Completion: _____ Contract Amount: \$ _____
3. Name (Firm/Agency): _____
Address: _____
Contact Person: _____ Telephone No. _____
Title of Project: _____
Project Location: _____
Date of Completion: _____ Contract Amount: \$ _____
4. Name (Firm/Agency): _____
Address: _____
Contact Person: _____ Telephone No. _____
Title of Project: _____
Project Location: _____
Date of Completion: _____ Contract Amount: \$ _____

| OWNER | Phone# - City | JOB NAME/LOCATION/ CONTRACT# | CONTACT PERSON | BOX # | ESTIMATED CONTRACT AMOUNT | Date First - Last on Job | FOREMAN |
|------------------|---------------|---|-------------------|-------|---------------------------------|--------------------------------|--------------|
| Glendora | 626-335-6175 | Cullen Avenue Wawer & Street Improvements #1317 & #1329 | Joseph Velosa | 92 | \$ 411,180.90 | 1/31/2022 - 3/15/2022 | Rodney |
| Montclair | 909-625-9444 | Modular Restroom Facilities | Steve Stanton | 95 | \$ 71,380.00 | 9/1/2022 - 9/21/2022 | Wayne |
| Ontario | | Water Main Replacement PHII | | | \$ 6,733,323.98 | 3/13/2023 - In Progress | Gilbert |
| Rancho Cucamonga | 909-477-2730 | CDBG Concrete Rehabilitation | Kenneth Fung | 96 | \$ 1,378,207.60 | 5/2/2022 - 2/16/2023 | Rodney |
| Covina | | Citrus Avenue Rehabilitation Project #P2010 | | | \$ 1,430,352.25 | 9/9/2022 - 6/5/2023 | Gilbert |
| Arcadia | 626-256-6653 | 2021/2022 Annual Concrete Repairs #55331022 | Jacquelyn Mercado | | \$ 105,730.00 | 7/22/2022 - 8/23/2022 | Marcos |
| Pomona | 909-620-2238 | Street Preservation FY 21-22 #426-68572 | Daniel Chung | | \$ 2,335,605.90 | 7/28/2022 - 3/13/2023 | Marcos |
| Covina | 626-384-5236 | Miscellaneous Concrete Project #P2203 | Valerie Cortez | 92 | \$ 119,521.00 | 5/31/2022 - 6/23/2022 | Richard |
| Downey | 562-904-7110 | City Yard Maintenance Pavement Rehabilitation #CIP 22-24 | Edward Torres | 95 | \$ 223,405.00 | 6/23/2022 - 7/13/2022 | Wayne |
| Covina | 626-384-5236 | Front Street Water Main Installation | Rafael Fajardo | | \$ 1,430,352.25 | 6/29/2023 - 8/29/2023 | Rodney |
| La Verne | | Sidewalk Replacement Various Locations PO#34317 | | 97 | \$ 99,633.00 | 8/15/2022 - 8/29/2022 | Steve |
| Claremont | | Claremont Blvd & Monte Vista Accessibility Improvements Project CIP 2021-1 | Steve | | \$ 585,765.00 | 9/21/2022 - 1/3/2023 | Wayne |
| Chino Hills | 909-364-2811 | Woodview Road Pavement Rehabilitation PHII #ST20012 | Deborah Hill | | \$ 320,931.00 | 6/19/2023 - 7/28/2023 | Marcos |
| La Verne | 909-596-8750 | Old Town Streetscape Improvements | | | \$ 1,624,894.20 | 11/14/2022 - 10/3/2023 | Jorge |
| Montclair | 909-625-9444 | CDBG Target Area Alley Improvements | Steve Stanton | | \$ 976,909.28 | 12/5/2022 - 1/31/2023 | Gonzalo |
| Brea | 714-671-4450 | Country Hills Subdivision Pavement & Water Imp PH 2 #CIP 7322 | | | \$ 2,125,523.60 | 2/1/2023 - 10/3/2023 | JJ Gilroyola |
| Rancho Cucamonga | 909-477-2740 | FY 22/23 Local Overlay Pavement Rehabilitation | | | \$ 4,751,061.00 | 2/1/2023 - 10/24/2023 | Rodney |
| Pomona | 909-802-7415 | Street Rehab - District 4 & 5 - #428-67922 - Fed STPL-5070(038 | Michael Lee | | \$ 1,539,544.74 | 2/8/2023 - In Progress | Marcos |
| Glendora | 626-335-6175 | Bennett Water & Street Improvements | Michael Dinh | | \$ 4,431,996.50 | 5/8/2023 In Progress | JJ Gilroyola |
| Glendora | 626-335-6175 | Cumberland Water & Street Improvements | Michael Dinh | | \$ 3,836,908.00 | 5/10/2023 - In Progress | Marcos |

| OWNER | Phone# - City | JOB NAME/LOCATION/ | CONTRACT# | CONTACT PERSON | BOX # | ESTIMATED CONTRACT AMOUNT | Date First - Last on Job | FOREMAN |
|------------------|---------------|---|-----------|-------------------|-------|---------------------------|--------------------------|---------|
| Pomona | | ADA Path of Travel, CDBG #428-6855, ADA Curb Ramps #428-67929 | | Michael Lee | 94 | \$ 1,323,000.00 | 3/22/2021- 11/10/2021 | Marcos |
| El Monte | 626-580-2065 | Valley Mall & Monterey | | Kristen Lloyd | 88 | \$ 29,050.00 | 2/9/2021 - 2/12/2021 | Gilbert |
| NA | | Cal Spas Drainage | | NA | 93 | \$ 84,104.00 | 02/19/2021 - 02/22/2021 | Gonzalo |
| Pomona | | Local Street Preservation 20-21 #428-68562 | | Daniel Chang | 94 | \$ 1,644,001.44 | 3/29/2021 - 12/10/2021 | Marcos |
| Alhambra | 626-570-5015 | 2020Concrete Repair Improvements #N2M20-161 | | | 91 | \$ 437,260.20 | 5/3/2021 - 7/13/2021 | Gilbert |
| Duarte | 626-357-7931 | 2020-2021 Street Rehabilitation | | Teresa Renteria | 90 | \$ 343,393.44 | 4/12/2021 - 5/4/2021 | Gilbert |
| West Covina | 626-939-8425 | FY 20-21 Resential Street Rehabilitation #21020 | | Miguel Hernandez | 94 | \$ 1,374,712.02 | 6/1/2021 - 8/10/2021 | Gilbert |
| Monterey | | Atlantic Water Main | | | 95 | \$ 885,503.40 | TERMINATED | |
| Ontario | | Water Main Replacement PH I | | Cunthia Torres | 97 | \$ 3,671,129.39 | 9/27/2021 - 10/6/2022 | Gilbert |
| Arcadia | 626-256-6653 | Live Oak Rehabilitation | | Kevin Merrill | 92 | \$ 1,566,620.23 | 8/9/2021 -10/13/2021 | Gonzalo |
| Alhambra | 626-570-5090 | Water Main & Street Rehabilitation | | Lauren Myles | 95 | \$ 981,161.10 | 2/11/2021 - 7/11/2022 | Rodney |
| Covina | | Street Rehabilitation | | Ratael Fajardo | 97 | \$ 1,317,227.25 | 7/30/2021 -11/10/2021 | Richard |
| San Dimas | 909-394-6248 | Covina et al Street Improvement CC2021-03 | | Shari Ganwick | 92 | \$ 1,298,484.70 | 9/27/2021 - 3/25/2022 | Richard |
| Covina | 626-384-5236 | Via Pakt Main Replacement | | Ratael Fajardo | 92 | \$ 398,060.00 | 8/19/2021 - 11/24/2021 | Gilbert |
| Rancho Cucamonga | | FY 21-22 Pavement Rehabilitation #8002021-02 | | Romeo David | 93 | \$ 1,178,830.84 | 10/25/2021 - 2/22/2022 | Wayne |
| Montebello | 323-887-1460 | Beach Street Pavement | | Samantha Chenelia | 96 | \$ 926,849.00 | 4/1/2022 - 8/22/2022 | Richard |
| Upland | 909-291-2946 | Civic Center Area Paving & ADA Improvements #82336 𒄔 | | Bob Critchfield | 92 | \$ 369,993.00 | 2/23/2022 - 7/1/2022 | Richard |
| Chino Hills | 909-364-2766 | Los Serranos Safe Routes to School East #ST210005 | | Steve Nix | 97 | \$ 866,872.80 | 3/7/2022 - 7/29/2022 | Marcos |
| Chino | 909-334-3415 | Alley/Sanitation Rehabilitation FY 202-21 @SN-211 | | Austin Pastovopit | 98 | \$ 1,423,393.75 | 3/14/2022 - 2/7/2023 | Gonzalo |
| Chino Hills | 909-364-2862 | Saddle Replacement PH 3 - #W17001 | | Michelle Smith | 98 | \$ 1,183,700.00 | 8/1/2022 - 2/3/2023 | Marcos |
| Montclair | 909-625-9444 | Zone 5 & 6 Street Rehabilitation #21002 | | Steve Stanton | | \$ 3,598,603.23 | 6/15/2022 - 3/31/2023 | Marcos |

| OWNER | Phone# - City | JOB NAME/LOCATION/ CONTRACT# | CONTACT PERSON | BOX # | ESTIMATED CONTRACT AMOUNT | Date First - Last on Job | FOREMAN |
|------------------|---------------|---|-------------------|-------|---------------------------|--------------------------|----------------|
| Walnut | | Emergency Work - Lemon Creek | | 85 | \$ 14,800.00 | 1/8/2020 - 1/17/2020 | NA |
| Covina | 626-384-5236 | Trip Road Imp/Phase II | Kristen Weger | 85 | \$ 1,728,775.00 | 2/3/2020 -5/5/2020 | Rodney |
| Downey | 562-622-3468 | Capital Improvement Project #19-04 - Samoline Avenue | Desi Gutierrez | 85 | \$ 717,800.00 | 2/3/2020 - 5/19/2020 | Gilbert |
| La Verne | 909-596-8750 | Emergency - Channel Crossings | Anthony Ciotti | 85 | \$ 26,000.00 | 1/27/2020 - 01/30/2020 | Gilbert |
| Baldwin Park | 626-960-4011 | Maine Avenue - PH I | Sam Gutierrez | 84 | \$ 1,715,418.60 | 3/9/2020 - 6/30/2020 | Art/Marcos |
| Baldwin Park | 626-960-4011 | ATP Cycle 3 Pacific Ave. | Sam Gutierrez | 88 | \$ 2,112,094.90 | 5/13/2020 - 10/2/2020 | Marcos |
| West Covina | 626-939-8425 | FY 2019-20 Residential Street Rehabilitation | Miguel Hernandez | 89 | \$ 969,070.55 | 6/1/2020 - 6/12/2020 | Rodney |
| Sierra Madre | 626-355-7135 | FY 2019-20 Street Improvement | Bruce Inman | 85 | \$ 443,940.10 | 4/20/2020 - 5/19/2020 | Rodney |
| Diamond Bar | 909-839-7010 | CDBG Area 1 Curb Ramp Project #60106919 | Tommye Cribbins | 89 | \$ 129,820.00 | 6/8/2020 - 7/21/2020 | Gonzalo |
| Pomona | | Street Preservation - #428-68561 FY19-20 | | 90 | \$ 1,866,732.42 | 6/24/2020 - 12/23/2020 | Rodney |
| Rancho Cucamonga | 909-477-270 | 2019/20 Arterial Pavement Rehabilitation - #800-2017-11 | Shelley Hayes | 91 | \$ 856,368.00 | 8/20/2020 - 11/6/2020 | Wayne |
| Covina | | Badillo Street Rehabilitation - #P1901-W2003 | | 88 | \$ 2,484,067.00 | 8/3/2020 -1/27/2021 | Gonzalo |
| Baldwin Park | 626-960-4011 | Morgan Park Parking Lot - City Project#CIP20-163 | Sam Gutierrez | 90 | \$ 390,920.00 | 5/13/2020 - 9/22/2020 | Marcos |
| Claremont | 909-399-5459 | Guardrail Replacement | Michelle Gonzales | 89 | \$ 48,500.00 | 7/22/2020 - 8/19/2020 | Wayne |
| Chino | | FY 15/16 Alley Reconstruction | | 95 | \$ 1,816,952.85 | 12/7/2020 -10/4/2021 | Gonzalo |
| Montclair | 909-625-9444 | Holt Boulevard Pavement Rehabilitation | Steve Stanton | 89 | \$ 886,393.28 | 10/5/2020 - 11/17/2020 | Rodney |
| Covina | 626-384-5236 | Concrete Repairs | Kristen Weger | 95 | \$ 156,737.50 | 10/5/2020 - 10/30/2020 | Gonzalo |
| Industry | | Temple Ave Dual Right Turn CITY-1458 | | 91 | \$ 498,028.00 | 1/13/2021 - 3/19/2021 | Rodney |
| La Verne | | "D" Street Overlay Parkway Renovation | | 90 | \$ 98,718.00 | 12/7/2020 - 12/22/2020 | Gonzalo |
| Upland | | Alley & Access Road Improvements #8801/8802/8803/86001 | | 91 | \$ 803,780.60 | 12/7/2020 - 5/4/2021 | Gilbert/Marcos |
| Brea | | Country Lane Street Rehabilitation | | 91 | \$ 279,738.24 | 1/13/2021 - 2/11/2021 | Gonzalo |
| Downey | | Telegraph Road Throughput & Safety Enhancements | Jasmine Fakhouri | 99 | \$ 6,322,707.13 | 5/3/2021 - 3/4/2022 | Rodney |

| OWNER | Phone# - City | JOB NAME/LOCATTION/ | CONTRACT# | CONTACT PERSON | BOX # | ESTIMATED CONTRACT AMOUNT | Date First - Last on Job | FOREMAN |
|------------------------|---------------|--|-----------|------------------|-------|---------------------------|--------------------------|-------------|
| Baldwin Park | 626-960-4011 | City Project #2018-0269 Various Locations | | Sam Gutierrez | 81 | \$ 1,757,175.50 | 3/28/2019 - 5/22/2019 | Rudy |
| La Verne | 909-596-8750 | 2018-19 Pavment Management Program | | Anthony Ciotti | 81 | \$ 579,638.20 | 2/27/2019 - 3/21/2019 | Rodney |
| Sierra Madre | 626-355-7135 | FY 2018-19 Street Improvement | | Bruce Inman | 85 | \$ 654,709.25 | 4/22/2019 - 6/28/2019 | Rodney |
| El Monte | NA | Emergency Work - Valve Replacement Tyler & Irish | | NA | 95 | \$ 14,653.33 | 3/1/2019 - 3/1/2019 | Gilbert |
| Jurupa Valley | | Jurupa Valley - Emergency Culvert Repair | | Steve Loriso | 80 | \$ 29,657.48 | 2/15/2019 - 2/19/2019 | Rudy |
| La Verne | 909-596-8750 | 2018-19 PMP Various Locations | | Anthony Ciotti | 83 | \$ 425,802.50 | 4/29/2019 - 5/14/2019 | Steve |
| La Verne | 909-596-8750 | CDBG Sidewalk Project #1401123 | | Anthony Ciotti | 81 | \$ 98,800.00 | 5/27/2019- 6/7/2019 | Steve |
| La Verne | 909-596-8750 | Baseline Road | | Anthony Ciotti | 83 | \$ - | 6/1/2019 - 6/21/2019 | Marcos |
| Pomona | 909-802-7415 | Street Preservation/ Local and Alleys | | Steve Enna | | \$ 3,995,744.00 | 6/17/2019 -10/30/2019 | Rudy/Pomona |
| Montclair | 909-625-9444 | San Jose Street Rehabilitation - #17022 | | Steve Stanton | 83 | \$ 286,929.00 | 7/1/2019 - 7/29/2019 | Marcos |
| Walnut | 909-594-9702 | La Puente Road Rehabilitation - #178975 | | Jason Weldon/RKA | 84 | \$ 593,622.50 | 7/1/19 - 10/21/2019 | Rodney |
| San Dimas | 909-934-6248 | Avenida Entrada Street Improvements | | Brandon Slater | 85 | \$ 897,998.00 | 8/5/2019 - 11/26/2019 | Rodney |
| City of Industry | 626-333-2211 | Resurfacing of Don Julian Road | | Kristen Weger | 93 | \$ 806,400.00 | 10/26/2020 - 01/01/2022 | Rodney |
| City of Baldwin Park | 626-960-4011 | SB1 Puente Avenue Street Improvements | | Sam Gutierrez | 84 | \$ 1,071,867.00 | 11/18/2019 - 3/14/2020 | Gilbert |
| City of Duarte | 626-357-7931 | Removal of Barriers for ADA Ramps | | Terres Renteria | 85 | \$ 41,080.00 | 12/2/2019 - 12/17/2019 | Rodney |
| City of Chino Hills | 909-364-2766 | Los Serranos Transit #S19001 | | Steven Nix | 84 | \$ 397,210.00 | 1/6/2020 -5/19/2020 | Rodney |
| City of South Pasadena | 626-403-7240 | Alpha Ave/Melva Street Improvement | | Kevin Ko | 89 | \$ 1,698,910.00 | 4/28/2020 - 10/27/2020 | Gilbert |
| City of Montebello | 323-887-1200 | Beverly Boulevard Improvements | | Roberta Lacayo | 90 | \$ 739,951.20 | 5/11/2020 - 6/25/2020 | Rodney |
| City of Industry | 626-333-2211 | Annual Street Rehabilitation #CIP-STR-19-043-B | | Gerry Perez | 89 | \$ 420,492.00 | 2/26/2020 - 9/22/2020 | Marcos |
| City of Montclair | 909-625-9444 | Emergency Road Work | | Steve Stanton | 89 | \$ 110,000.00 | 1/8/2020 - 1/20/2020 | Gilbert |

| OWNER | Phone# - City | JOB NAME/LOCATION/ CONTRACT# | CONTACT PERSON | BOX # | ESTIMATED CONTRACT AMOUNT | Date First - Last on Job | FOREMAN |
|---------------|---------------|---|-------------------|---------|---------------------------------|-----------------------------|---------|
| Covina | 626-384-5236 | Cypress Reservoir Drainage Improvemets | Kristen Weagar | 78 | \$ 97,680.00 | 4/18/2018 -5/11/2018 | David |
| Baldwin Park | 626-960-4011 | Residential Street Rehabilitation - #2018-02220 | Sam Gutierrez | 83 | \$ 653,070.00 | 4/3/2018 - 5/29/18 | Rodney |
| LACDPW | 626-458-3111 | Ballentine Pl. et al - Project #RDCC0015528 | Harry Cong | 82 | \$ 4,600,159.75 | 6/13/2018 - 2/8/2019 | Rodney |
| Glendora | 626-914-8216 | Pasadena Avenue Street Rehabilitation #1243 | Harutyun Mesopyah | 78 | \$ 168,712.10 | 3/19/2018 - 4/9/2018 | Steve |
| Covina | 626-384-5236 | Grand Avenue Water Line Upgrade | Kristen Weagar | 79 | \$ 1,289,295.00 | 4/3/2018- 10/9/2016 | Gilbert |
| Glendora | 626-335-6175 | Auto Centre Dr/Amelia Avenue Improvement Project #1183/#1202 | Joseph Velosa | 78 | \$ 896,840.00 | 4/3/2018 -5/29/2018 | Arturo |
| Whittier | 562-567-9500 | 18-011 Hoover Avenue Water Main Replacement | Sunny Ng | 82 | \$ 1,513,600.00 | 7/2/2018 - 2/8/2019 | David |
| Montclair | 909-625-9444 | Zone 4 Montclair Street Rehabilitation | Steve Stanton | 80 | \$ 3,696,445.00 | 5/14/2018 - 12/27/2018 | Arturo |
| La Verne | 909-596-8750 | "E" Street "8" Water Main | Anthony Ciotti | 79 | \$ 773,658.00 | 6/11/2018 - 10/2/2018 | David |
| La Verne | 909-596-8750 | 2017-2018 CDBG Sidewalk Improvements | Anthony Ciotti | 79 | \$ 54,600.00 | 4/30/2018 - 5/8/2018 | Rodney |
| La Verne | 909-596-8750 | Island Medians - Wheeler Avenue | Anthony Ciotti | 78 | \$ 97,512.00 | 5/9/2018 - 5/14/2018 | Rodney |
| La Verne | 909-596-8750 | Wheeler Avenue Pavement Rehabilitation | Anthony Ciotti | 78 | \$ 690,300.00 | 6/5/2018 - 8/20/2018 | Rodney |
| Glendora | | Emergency - Juanita Ave | | 80 | \$ 29,657.48 | 2/15/2018 - 2/19/2018 | Gilbert |
| Montclair | 909-625-9444 | Central Avenue Alley Improvements | Steve Stanton | 80 | \$ 223,825.00 | 9/26/2018 - 10/30/2018 | Arturo |
| Upland | 909-291-2946 | Linda Way Reconstruction/Utility Imp #7061 | Bob Critchfield | 80 | \$ 356,375.00 | 8/30/2018 - 12/28/2018 | Wayne |
| Covina | 626-384-5236 | Trip Road Improvement - Phase I | Kristen Weagar | 81 | \$ 2,433,358.00 | 9/25/2018 - 3/4/2019 | Gilbert |
| Upland | 909-291-2946 | San Antonio Pavement Rehabilitation | Bob Critchfield | 79 | \$ 536,200.00 | 8/30/2018- 8/30/2018 | Wayne |
| Claremont | 909-399-5395 | Foothill Boulevard Mast Plan Improvement | Vincent Ramos | 87/2Bxs | \$ 13,987,678.00 | 11/5/2018 -9/8/2020 | Arturo |
| Glendora | 626-914-8255 | Lorraine Avenue Water #1240 | Debbie Wood | 83 | \$ 2,157,500.00 | 2/6/2019 - 11/8/2019 | Gilbert |
| Glendora | 626-914-8216 | Lone Hill Avenue Street Improvements #1274 | Bardia Raston | 81 | \$ 840,625.00 | 3/18/2019 - 4/25/2019 | Rodney |
| Glendora | 626-335-6175 | CDBG Laxford Street & Vencino Avenue Street Improvements #1277 | Joseph Velosa | 80 | \$ 216,144.36 | 2/11/2019 - 2/21/2019 | Rodney |
| Jurupa Valley | | Jurupa Valley Emergency | | 80 | \$ 29,657.48 | 2/15/2109 - 2/19/2019 | Rudy |
| Baldwin Park | 626-960-4011 | Chevalier Drainage Project | Sam Gutierrez | 81 | \$ 106,620.00 | 2/25/2019 - 3/12/2019 | Rodney |

| OWNER | Phone# - City | JOB NAME/LOCATION/ CONTRACT# | CONTACT PERSON | BOX # | ESTIMATED CONTRACT AMOUNT | Date First - Last on Job | FOREMAN |
|------------------------|---------------|--|--------------------|-------|---------------------------|--------------------------|------------|
| Upland | 909-291-2961 | 16th Street Rehabilitation - #7049, 7050, 7055 | Enayat Khugyani | 76 | \$ 1,635,117.60 | 5/1/2016 - 9/29/2017 | Arturo |
| San Gabriel | 909-594-9702 | 2016 CDBG Street Improvement - #601747-15 | Micahel Lee (RKA) | 73 | \$ 234,329.20 | 5/8/2017 - 6/1/2017 | Rodney |
| Ontario | 909-395-2000 | Holt Ave/Melrose Street Improvements | Charly Hernandez | 77 | \$ 1,046,195.60 | 6/5/2017 - 10/10/2017 | Rodney |
| La Verne | 909-596-8741 | 2016-2017 CDBG Sidewalk Improvements | Anthony Ciotti | 73 | \$ 150,000.00 | 7/14/2017 - 8/2/2017 | Steve |
| Montebello | 323-887-1448 | Street Improvements - Frankel Ave | Vahid Hormoz | 73 | \$ 174,490.00 | 7/31/2017 - 8/10/2017 | Steve |
| Covina | 909-594-9702 | Casad Water System Upgrade | Brandon Chen @ RKA | 77 | \$ 140,000.00 | 8/25/2017 - 1/30/2018 | Gilbert |
| San Dimas | 909-394-6248 | Cienega Ave. Reconstructin - Arrow Hwy/Lone Hill | Shari Garwick | 76 | \$ 1,221,970.00 | 8/14/2017 - 11/15/2017 | Arturo |
| Upland | 909-291-2961 | Citywide Sewer Manhole Rehabilitation - #9328 | Enayat Khugyani | 78 | \$ 279,500.00 | 11/15/2017 - 1/5/2018 | Rudy/Steve |
| Baldwin Park | 626-960-4011 | City Project #2017-0185 - Alley Ways Imp | Carlos Aguirre | 76 | \$ 290,848.00 | 10/2/2017 - 10/24/2017 | Rudy/Steve |
| Glendora | 626-914-8216 | Glendora Ave Water - #1238 | Harlyun Mesopyah | 76 | \$ 395,000.00 | 10/6/2017 - 12/6/2017 | Rodney |
| Rubio Canon Land/Water | | Meadowbrook Road Mainline Replacement | | 78 | \$ 284,375.00 | 2/20/2018 - 4/2/2018 | Gilbert |
| La Verne | 909-596-8741 | Esperanza Drive Pavement Rehabilitation | Anthony Ciotti | 73 | \$ 230,276.20 | 9/12/2017 - 9/22/2017 | Steve |
| Pomona | 909-620-2261 | Major Street Rehab/Bicycle/Pedestrian Improvements | Matt Pilarz | 74/75 | \$ 2,750,939.00 | 1/22/2018 - 8/20/2018 | Rodney |
| La Verne | 909-596-8741 | Winterhaven Drive et al | Anthony Ciotti | 76 | \$ 570,524.35 | 10/9/2017 - 10/31/2017 | Arturo |
| Baldwin Park | 626-960-4011 | Ramona Ave @ Francisquito Storm Drain | Carlos Aguirre | 77 | \$ 156,760.00 | 10/30/2017 - 11/14/2017 | Rudy/Steve |
| Montclair | 909-625-9444 | Orchard Street | Steve Stanton | 77 | \$ 1,376,900.00 | 10/30/2017 - 1/26/2018 | Arturo |
| Pomona | 909-620-2261 | ADA Path of Travel Improvements | Matt Pilarz | 83 | \$ 734,205.00 | 2/5/2018 - 5/23/18 | Rudy |
| Santa Fe Springs | 562-868-0511 | Greenleaf Avenue Street Rehabilitation | Robert Garcia | 79 | \$ 989,155.00 | 1/2/2018 - 4/26/18 | Arturo |
| Covina | | Barranca Avenue Emergency Water | | 79 | \$ 164,187.00 | 6/13/2018 - 8/20/2018 | Gilbert |

If Contractor has not performed work for the City of La Habra within the last five (5) years, list all work done within said five years (attach additional sheets if necessary). Note if work was done as subcontractor (include only subcontract amount):

| Work Description & Contract Amount | Agency | Date Completed |
|------------------------------------|--------|----------------|
| ATTACHED | | |
| | | |
| | | |
| | | |
| | | |

Contractor's License No.: 397682 Class: A

a. Date first obtained: 1981 Expiration: 12-25

b. Has License ever been suspended or revoked? NO

If yes, described when and why: _____

c. Any current claims against License or Bond? NO

If yes, describe claims: _____

Principals in Company (List all – attach additional sheets if necessary):

| <u>NAME</u> | <u>TITLE</u> | <u>LICENSE NO.</u> (If Applicable) |
|---------------|--------------|---------------------------------------|
| WAYNE GENTILE | SEC. TREES | |
| _____ | _____ | _____ |
| _____ | _____ | _____ |

| OWNER | Phone# - City | JOB NAME/LOCATION/ CONTRACT# | CONTACT PERSON | BOX # | ESTIMATED CONTRACT AMOUNT | Date First - Last on Job | FOREMAN |
|------------------|------------------|---|-------------------|-------|---------------------------------|-----------------------------|--------------|
| Glendora | 626-335-6175 | Cullen Avenue Wawer & Street Improvements #1317 & #1329 | Joseph Velosa | 92 | \$ 411,180.90 | 1/31/2022 - 3/15/2022 | Rodney |
| Montclair | 909-625-9444 | Modular Restroom Facilities | Steve Stanton | 95 | \$ 71,380.00 | 9/1/2022 - 9/21/2022 | Wayne |
| Ontario | | Water Main Replacement PHII | | | \$ 6,733,323.98 | 3/13/2023 - In Progress | Gilbert |
| Rancho Cucamonga | 909-477-2730 | CDBG Concrete Rehabilitation | Kenneth Fung | 96 | \$ 1,378,207.60 | 5/2/2022 - 2/16/2023 | Rodney |
| Covina | | Citrus Avenue Rehabilitation Project #P2010 | | | \$ 1,430,352.25 | 9/9/2022 - 6/5/2023 | Gilbert |
| Arcadia | 626-256-6653 | 2021/2022 Annual Concrete Repairs #55331022 | Jacquelyn Mercado | | \$ 105,730.00 | 7/22/2022 - 8/23/2022 | Marcos |
| Pomona | 909-620-2238 | Street Preservation FY 21-22 #426-68572 | Daniel Chung | | \$ 2,335,605.90 | 7/28/2022 - 3/13/2023 | Marcos |
| Covina | 626-384-5236 | Miscellaneous Concrete Project #P2203 | Valerie Cortez | 92 | \$ 119,521.00 | 5/31/2022 - 6/23/2022 | Richard |
| Downey | 562-904-7110 | City Yard Maintenance Pavement Rehabilitation #CIP 22-24 | Edward Torres | 95 | \$ 223,405.00 | 6/23/2022 - 7/13/2022 | Wayne |
| Covina | 626-384-5236 | Front Street Water Main Installation | Rafael Fajardo | | \$ 1,430,352.25 | 6/29/2023 - 8/29/2023 | Rodney |
| La Verne | | Sidewalk Replacement Various Locations PO#34317 | | 97 | \$ 99,633.00 | 8/15/2022 - 8/29/2022 | Steve |
| Claremont | | Claremont Blvd & Monte Vista Accessibility Improvements Project CIP 2021-1 | Steve | | \$ 585,765.00 | 9/21/2022 - 1/3/2023 | Wayne |
| Chino Hills | 909-364-2811 | Woodview Road Pavement Rehabilitation PHII #ST20012 | Deborah Hill | | \$ 320,931.00 | 6/19/2023 - 7/28/2023 | Marcos |
| La Verne | 909-596-8750 | Old Town Streetscape Improvements | | | \$ 1,524,894.20 | 11/14/2022 - 10/3/2023 | Jorge |
| Montclair | 909-625-9444 | CDBG Target Area Alley Improvements | Steve Stanton | | \$ 976,909.28 | 12/5/2022 - 1/31/2023 | Gonzalo |
| Brea | 714-671-4450 | Country Hills Subdivision Pavement & Water Imp PH 2 #CIP 7322 | | | \$ 2,125,523.60 | 2/1/2023 - 10/3/2023 | JJ Gilroyola |
| Rancho Cucamonga | 909-477-2740 | FY 22/23 Local Overlay Pavement Rehabilitation | | | \$ 4,751,061.00 | 2/1/2023 - 10/24/2023 | Rodney |
| Pomona | 909-802-7415 | Street Rehab - District 4 & 5 - #428-67922 - Fed STPL-5070/038 | Michael Lee | | \$ 1,539,544.74 | 2/8/2023 - In Progress | Marcos |
| Glendora | 626-335-6175 | Bennett Water & Street Improvements | Michael Dinh | | \$ 4,431,996.50 | 5/8/2023 In Progress | JJ Gilroyola |
| Glendora | 626-335-6175 | Cumberland Water & Street Improvements | Michael Dinh | | \$ 3,836,908.00 | 5/10/2023 - In Progress | Marcos |

| OWNER | Phone# - City | JOB NAME/LOCATION/ CONTRACT# | CONTACT PERSON | BOX # | ESTIMATED CONTRACT AMOUNT | Date First - Last on Job | FOREMAN |
|------------------|---------------|---|-------------------|-------|---------------------------|--------------------------|---------|
| Pomona | | ADA Path of Travel, CDBG #428-6855, ADA Curb Ramps #428-67929 | Michael Lee | 94 | \$ 1,323,000.00 | 3/22/2021 - 11/10/2021 | Marcos |
| El Monte | 626-580-2065 | Valley Mall & Monterey | Kristen Lloyd | 88 | \$ 29,050.00 | 2/9/2021 - 2/12/2021 | Gilbert |
| NA | | Cal Spas Drainage | NA | 93 | \$ 84,104.00 | 02/19/2021 - 02/22/2021 | Gonzalo |
| Pomona | | Local Street Preservation 20-21 #428-68562 | Daniel Chang | 94 | \$ 1,644,001.44 | 3/29/2021 - 12/10/2021 | Marcos |
| Alhambra | 626-570-5015 | 2020Concrete Repair Improvements #N2M20-161 | | 91 | \$ 437,260.20 | 5/3/2021 - 7/13/2021 | Gilbert |
| Duarte | 626-357-7931 | 2020-2021 Street Rehabilitation | Teresa Renteria | 90 | \$ 343,393.44 | 4/12/2021 - 5/4/2021 | Gilbert |
| West Covina | 626-939-8425 | FY 20-21 Resesntial Street Rehabilitation #21020 | Miguel Hernandez | 94 | \$ 1,374,712.02 | 6/1/2021 - 8/10/2021 | Gilbert |
| Monterey | | Atlantic Water Main | | 95 | \$ 885,503.40 | TERMINATED | |
| Ontario | | Water Main Replacement PH I | Cunthia Torres | 97 | \$ 3,671,129.39 | 9/27/2021 - 10/6/2022 | Gilbert |
| Arcadia | 626-256-6653 | Live Oak Rehabilitation | Kevin Merrill | 92 | \$ 1,566,620.23 | 8/9/2021 - 10/13/2021 | Gonzalo |
| Alhambra | 626-570-5090 | Water Main & Street Rehabilitation | Lauren Myles | 95 | \$ 981,161.10 | 2/11/2021 - 7/11/2022 | Rodney |
| Covina | | Street Rehabilitation | Rafael Fajardo | 97 | \$ 1,317,227.25 | 7/30/2021 - 11/10/2021 | Richard |
| San Dimas | 909-394-6248 | Covina et al Street Improvement CC2021-03 | Shari Garwick | 92 | \$ 1,298,484.70 | 9/27/2021 - 3/25/2022 | Richard |
| Covina | 626-384-5236 | Via Pakt Main Replacement | Rafael Fajardo | 92 | \$ 398,060.00 | 8/19/2021 - 11/24/2021 | Gilbert |
| Rancho Cucamonga | | FY 21-22 Pavement Rehabilitation #8002021-02 | Romeo David | 93 | \$ 1,178,830.84 | 10/25/2021 - 2/22/2022 | Wayne |
| Montebello | 323-887-1460 | Beach Street Pavement | Samantha Chenela | 96 | \$ 926,849.00 | 4/11/2022 - 8/22/2022 | Richard |
| Upland | 909-291-2946 | Civic Center Area Paving & ADA Improvements #82336 & #74004 | Bob Critchfield | 92 | \$ 369,993.00 | 2/23/2022 - 7/11/2022 | Richard |
| Chino Hills | 909-364-2766 | Los Serranos Safe Routes to School East #ST210005 | Steve Nix | 97 | \$ 866,872.80 | 3/7/2022 - 7/29/2022 | Marcos |
| Chino | 909-334-3415 | Alley/Sanitation Rehabilitation FY 202-21 @SN-211 | Austin Pastovopit | 98 | \$ 1,423,393.75 | 3/14/2022 - 2/7/2023 | Gonzalo |
| Chino Hills | 909-364-2862 | Saddle Replacement PH 3 - #W17001 | Michelle Smith | 98 | \$ 1,183,700.00 | 8/11/2022 - 2/3/2023 | Marcos |
| Montclair | 909-625-9444 | Zone 5 & 6 Street Rehabilitation #21002 | Steve Stanton | | \$ 3,598,603.23 | 6/15/2022 - 3/31/2023 | Marcos |

| OWNER | Phone# - City | JOB NAME/LOCATION/ CONTRACT # | CONTACT PERSON | BOX # | ESTIMATED CONTRACT AMOUNT | Date First - Last on Job | FOREMAN |
|------------------|---------------|---|-------------------|-------|---------------------------|--------------------------|----------------|
| Walnut | | Emergency Work - Lemon Creek | | 85 | \$ 14,800.00 | 1/8/2020 - 1/17/2020 | NA |
| Covina | 626-384-5236 | Trip Road Imp/Phase II | Kristen Weger | 85 | \$ 1,728,775.00 | 2/3/2020 - 5/5/2020 | Rodney |
| Downey | 562-622-3468 | Capital Improvement Project #19-04 - Sarnoline Avenue | Desi Gutierrez | 85 | \$ 717,800.00 | 2/3/2020 - 5/19/2020 | Gilbert |
| La Verne | 909-596-8750 | Emergency - Channel Crossings | Anthony Ciotti | 85 | \$ 26,000.00 | 1/27/2020 - 01/30/2020 | Gilbert |
| Baldwin Park | 626-960-4011 | Maine Avenue - PH I | Sam Gutierrez | 84 | \$ 1,715,418.60 | 3/9/2020 - 6/30/2020 | Art/Marcos |
| Baldwin Park | 626-960-4011 | ATP Cycle 3 Pacific Ave. | Sam Gutierrez | 88 | \$ 2,112,094.90 | 5/13/2020 - 10/2/2020 | Marcos |
| West Covina | 626-939-8425 | FY 2019-20 Residential Street Rehabilitation | Miguel Hernandez | 89 | \$ 969,070.55 | 6/1/2020 - 6/12/2020 | Rodney |
| Sierra Madre | 626-355-7135 | FY 2019-20 Street Improvement | Bruce Inman | 85 | \$ 443,940.10 | 4/20/2020 - 5/19/2020 | Rodney |
| Diamond Bar | 909-839-7010 | CDBG Area 1 Curb Ramp Project #60106919 | Tommye Cribbins | 89 | \$ 129,820.00 | 6/8/2020 - 7/21/2020 | Gonzalo |
| Pomona | | Street Preservation - #428-68561 FY19-20 | | 90 | \$ 1,866,732.42 | 6/24/2020 - 12/23/2020 | Rodney |
| Rancho Cucamonga | 909-477-270 | 2019/20 Arterial Pavement Rehabilitation - #800-2017-11 | Shelley Hayes | 91 | \$ 856,368.00 | 8/20/2020 - 11/6/2020 | Wayne |
| Covina | | Badillo Street Rehabilitation - #P1901-W2003 | | 88 | \$ 2,484,067.00 | 8/3/2020 - 1/27/2021 | Gonzalo |
| Baldwin Park | 626-960-4011 | Morgan Park Parking Lot - City Project#CJP20-163 | Sam Gutierrez | 90 | \$ 390,920.00 | 5/13/2020 - 9/22/2020 | Marcos |
| Claremont | 909-399-5459 | Guardrail Replacement | Michelle Gonzales | 89 | \$ 48,500.00 | 7/22/2020 - 8/19/2020 | Wayne |
| Chino | | FY 15/16 Alley Reconstruction | | 95 | \$ 1,816,952.85 | 12/7/2020 - 10/4/2021 | Gonzalo |
| Montclair | 909-625-9444 | Holt Boulevard Pavement Rehabilitation | Steve Stanton | 89 | \$ 886,393.28 | 10/5/2020 - 11/17/2020 | Rodney |
| Covina | 626-384-5236 | Concrete Repairs | Kristen Weger | 95 | \$ 156,737.50 | 10/5/2020 - 10/30/2020 | Gonzalo |
| Industry | | Temple Ave Dual Right Turn CITY-1458 | | 91 | \$ 498,028.00 | 1/13/2021 - 3/19/2021 | Rodney |
| La Verne | | "D" Street Overlay Parkway Renovation | | 90 | \$ 98,718.00 | 12/7/2020 - 12/22/2020 | Gonzalo |
| Upland | | Alley & Access Road Improvements #8801/8802/8803/86001 | | 91 | \$ 803,780.60 | 12/7/2020 - 5/4/2021 | Gilbert/Marcos |
| Brea | | Country Lane Street Rehabilitation | | 91 | \$ 279,738.24 | 1/13/2021 - 2/11/2021 | Gonzalo |
| Downey | | Telegraph Road Throughput & Safety Enhancements | Jasmine Fakhouri | 99 | \$ 6,322,707.13 | 5/3/2021 - 3/4/2022 | Rodney |

| OWNER | Phone# - City | JOB NAME/LOCATION/ | CONTRACT# | CONTACT PERSON | BOX # | ESTIMATED CONTRACT AMOUNT | Date First - Last on Job | FOREMAN |
|------------------------|---------------|--|-----------|-----------------|-------|---------------------------|--------------------------|-------------|
| Baldwin Park | 626-960-4011 | City Project #2018-0269 Various Locations | | Sam Gutierrez | 81 | \$ 1,757,175.50 | 3/28/2019 - 5/22/2019 | Rudy |
| La Verne | 909-596-8750 | 2018-19 Pavment Management Program | | Anthony Ciotti | 81 | \$ 579,638.20 | 2/27/2019 - 3/21/2019 | Rodney |
| Sierra Madre | 626-355-7135 | FY 2018-19 Street Improvement | | Bruce Imman | 85 | \$ 654,709.25 | 4/22/2019 - 6/28/2019 | Rodney |
| El Monte | NA | Emergency Work - Valve Replacement Tyler & Irish | | NA | 95 | \$ 14,653.33 | 3/1/2019 - 3/1/2019 | Gilbert |
| Jurupa Valley | | Jurupa Valley - Emergency Culvert Repair | | Steve Loriso | 80 | \$ 29,657.48 | 2/15/2019 - 2/19/2019 | Rudy |
| La Verne | 909-596-8750 | 2018-19 PMP Various Locations | | Anthony Ciotti | 83 | \$ 425,802.50 | 4/29/2019 - 5/14/2019 | Steve |
| La Verne | 909-596-8750 | CDBG Sidewalk Project #1401123 | | Anthony Ciotti | 81 | \$ 98,800.00 | 5/27/2019 - 6/7/2019 | Steve |
| La Verne | 909-596-8750 | Baseline Road | | Anthony Ciotti | 83 | \$ - | 6/11/2019 - 6/21/2019 | Marcos |
| Pomona | 909-802-7415 | Street Preservation/ Local and Alleys | | Steve Enna | | \$ 3,995,744.00 | 6/17/2019 - 10/30/2019 | Rudy/Pomona |
| Montclair | 909-625-9444 | San Jose Street Rehabilitation - #17022 | | Steve Stanton | 83 | \$ 286,929.00 | 7/1/2019 - 7/29/2019 | Marcos |
| Walnut | 909-594-9702 | La Puente Road Rehabilitation - #178975 | | Jason Welay/RKA | 84 | \$ 593,622.50 | 7/1/19 - 10/21/2019 | Rodney |
| San Dimas | 909-934-6248 | Avenida Entrada Street Improvements | | Brandon Slater | 85 | \$ 897,998.00 | 8/5/2019 - 11/26/2019 | Rodney |
| City of Industry | 626-333-2211 | Resurfacing of Don Julian Road | | Kristen Weger | 93 | \$ 806,400.00 | 10/26/2020 - 01/01/2022 | Rodney |
| City of Baldwin Park | 626-960-4011 | SB1 Puente Avenue Street Improvements | | Sam Gutierrez | 84 | \$ 1,071,867.00 | 11/18/2019 - 3/14/2020 | Gilbert |
| City of Duarte | 626-357-7931 | Removal of Barriers for ADA Ramps | | Teres Renleria | 85 | \$ 41,080.00 | 12/2/2019 - 12/17/2019 | Rodney |
| City of Chino Hills | 909-364-2766 | Los Serranos Transit #S19001 | | Steven Nix | 84 | \$ 397,210.00 | 1/6/2020 - 5/19/2020 | Rodney |
| City of South Pasadena | 626-403-7240 | Alpha Ave/Melva Street Improvement | | Kevin Ko | 89 | \$ 1,698,910.00 | 4/28/2020 - 10/27/2020 | Gilbert |
| City of Montebello | 323-887-1200 | Beverly Boulevard Improvements | | Roberta Lacayo | 90 | \$ 739,951.20 | 5/11/2020 - 6/25/2020 | Rodney |
| City of Industry | 626-333-2211 | Annual Street Rehabilitation #CIP-STR-19-043-B | | Gerry Perez | 89 | \$ 420,492.00 | 2/26/2020 - 9/22/2020 | Marcos |
| City of Montclair | 909-625-9444 | Emergency Road Work | | Steve Stanton | 89 | \$ 110,000.00 | 1/8/2020 - 1/20/2020 | Gilbert |

| OWNER | Phone# - City | JOB NAME/LOCATION/ CONTRACT# | CONTACT PERSON | BOX # | ESTIMATED CONTRACT AMOUNT | Date First - Last on Job | FOREMAN |
|---------------|---------------|---|-------------------|---------|---------------------------------|-----------------------------|---------|
| Covina | 626-384-5236 | Cypress Reservoir Drainage Improvements | Kristen Wegar | 78 | \$ 97,680.00 | 4/18/2018 - 5/11/2018 | David |
| Baldwin Park | 626-960-4011 | Residential Street Rehabilitation - #2018-0220 | Sam Gutierrez | 83 | \$ 653,070.00 | 4/3/2018 - 5/29/18 | Rodney |
| LACDPW | 626-458-3111 | Ballentine Pl. et al - Project #RDCC0015528 | Harry Cong | 82 | \$ 4,600,159.75 | 6/13/2018 - 2/8/2019 | Rodney |
| Glendora | 626-914-8216 | Pasadena Avenue Street Rehabilitation #1243 | Haruyun Mesopayah | 78 | \$ 168,712.10 | 3/19/2018 - 4/9/2018 | Steve |
| Covina | 626-384-5236 | Grand Avenue Water Line Upgrade | Kristen Wegar | 79 | \$ 1,289,295.00 | 4/3/2018 - 10/9/2016 | Gilbert |
| Glendora | 626-335-6175 | Auto Centre Dr/Amelia Avenue Improvement Project #1183#1202 | Joseph Velosa | 78 | \$ 896,840.00 | 4/3/2018 - 5/29/2018 | Arturo |
| Whittier | 562-567-9500 | 18-011 Hoover Avenue Water Main Replacement | Sunny Ng | 82 | \$ 1,513,600.00 | 7/2/2018 - 2/8/2019 | David |
| Montclair | 909-625-9444 | Zone 4 Montclair Street Rehabilitation | Steve Stanton | 80 | \$ 3,696,445.00 | 5/14/2018 - 12/27/2018 | Arturo |
| La Verne | 909-596-8750 | "E" Street "8" Water Main | Anthony Ciotti | 79 | \$ 773,658.00 | 6/11/2018 - 10/2/2018 | David |
| La Verne | 909-596-8750 | 2017-2018 CDBG Sidewalk Improvements | Anthony Ciotti | 79 | \$ 54,600.00 | 4/30/2018 - 5/8/2018 | Rodney |
| La Verne | 909-596-8750 | Island Medians - Wheeler Avenue | Anthony Ciotti | 78 | \$ 97,512.00 | 5/9/2018 - 5/14/2018 | Rodney |
| La Verne | 909-596-8750 | Wheeler Avenue Pavement Rehabilitation | Anthony Ciotti | 78 | \$ 690,300.00 | 6/5/2018 - 8/20/2018 | Rodney |
| Glendora | | Emergency - Juanita Ave | | 80 | \$ 29,657.48 | 2/15/2018 - 2/19/2018 | Gilbert |
| Montclair | 909-625-9444 | Central Avenue Alley Improvements | Steve Stanton | 80 | \$ 223,825.00 | 9/26/2018 - 10/30/2018 | Arturo |
| Upland | 909-291-2946 | Linda Way Reconstruction/Utility Imp #7061 | Bob Critchfield | 80 | \$ 356,375.00 | 8/30/2018 - 12/28/2018 | Wayne |
| Covina | 626-384-5236 | Trip Road Improvement - Phase I | Kristen Wegar | 81 | \$ 2,433,358.00 | 9/25/2018 - 3/4/2019 | Gilbert |
| Upland | 909-291-2946 | San Antonio Pavement Rehabilitation | Bob Critchfield | 79 | \$ 536,200.00 | 8/30/2018 - 8/30/2018 | Wayne |
| Claremont | 909-399-5395 | Foothill Boulevard Mast Plan Improvement | Vincent Ramos | 87/2Bxs | \$ 13,987,678.00 | 11/5/2018 - 9/8/2020 | Arturo |
| Glendora | 626-914-8255 | Loraine Avenue Water #1240 | Debbie Wood | 83 | \$ 2,157,500.00 | 2/6/2019 - 11/8/2019 | Gilbert |
| Glendora | 626-914-8216 | Lone Hill Avenue Street Improvements #1274 | Bardia Raston | 81 | \$ 840,625.00 | 3/18/2019 - 4/25/2019 | Rodney |
| Glendora | 626-335-6175 | CDBG Laxford Street & Vencino Avenue Street Improvements #1277 | Joseph Velosa | 80 | \$ 216,144.36 | 2/11/2019 - 2/21/2019 | Rodney |
| Jurupa Valley | | Jurupa Valley Emergency | | 80 | \$ 29,657.48 | 2/15/2109 - 2/19/2019 | Rudy |
| Baldwin Park | 626-960-4011 | Chevalier Drainage Project | Sam Gutierrez | 81 | \$ 106,620.00 | 2/25/2019 - 3/12/2019 | Rodney |

| OWNER | Phone# - City | JOB NAME/LOCATION/ CONTRACT# | CONTACT PERSON | BOX # | ESTIMATED CONTRACT AMOUNT | Date First - Last on Job | FOREMAN |
|------------------------|---------------|--|--------------------|-------|---------------------------|--------------------------|------------|
| Upland | 909-291-2961 | 16th Street Rehabilitation - #7049, 7050, 7055 | Enayat Khuyani | 76 | \$ 1,635,117.60 | 5/1/2016 - 9/29/2017 | Arturo |
| San Gabriel | 909-594-9702 | 2016 CDBG Street Improvement - #601747-15 | Micahel Lee (RKA) | 73 | \$ 234,329.20 | 5/8/2017 - 6/1/2017 | Rodney |
| Ontario | 909-395-2000 | Holt Ave/Melrose Street Improvements | Charity Hernandez | 77 | \$ 1,046,195.60 | 6/5/2017 -10/10/2017 | Rodney |
| La Verne | 909-596-8741 | 2016-2017 CDBG Sidewalk Improvements | Anthony Ciotti | 73 | \$ 150,000.00 | 7/14/2017 - 8/2/2017 | Steve |
| Montebello | 323-887-1448 | Street Improvements - Frankel Ave | Vahid Homroz | 73 | \$ 174,490.00 | 7/31/2017 - 8/10/2017 | Steve |
| Covina | 909-594-9702 | Casad Water System Upgrade | Brandon Chen @ RKA | 77 | \$ 140,000.00 | 8/25/2017 -1/30/2018 | Gilbert |
| San Dimas | 909-394-6248 | Cienega Ave. Reconstruction - Arrow Hwy/Lone Hill | Shari Garwick | 76 | \$ 1,221,970.00 | 8/14/2017 - 11/15/2017 | Arturo |
| Upland | 909-291-2961 | Citywide Sewer Manhole Rehabilitation - #9328 | Enayat Khuyani | 78 | \$ 279,500.00 | 11/15/2017 - 1/5/2018 | Rudy/Steve |
| Baldwin Park | 626-960-4011 | City Project #2017-0185 - Alley Ways Imp | Carlos Aguirre | 76 | \$ 290,848.00 | 10/2/2017 - 10/24/2017 | Rudy/Steve |
| Glendora | 626-914-8216 | Glendora Ave Water - #1238 | Haruyun Mesopyah | 76 | \$ 395,000.00 | 10/6/2017 - 12/6/2017 | Rodney |
| Rubio Canon Land/Water | | Meadowbrook Road Mainline Replacement | | 78 | \$ 284,375.00 | 2/20/2018 -4/2/2018 | Gilbert |
| La Verne | 909-596-8741 | Esperanza Drive Pavement Rehabilitation | Anthony Ciotti | 73 | \$ 230,276.20 | 9/12/2017 - 9/22/2017 | Steve |
| Pomona | 909-620-2261 | Major Street Rehab/Bicycle/Pedestrian Improvements | Matt Pilarz | 74/75 | \$ 2,750,939.00 | 1/22/2018 - 8/20/2018 | Rodney |
| La Verne | 909-596-8741 | Winterhaven Drive et al | Anthony Ciotti | 76 | \$ 570,524.35 | 10/9/2017 - 10/31/2017 | Arturo |
| Baldwin Park | 626-960-4011 | Ramona Ave @ Franciscuito Storm Drain | Carlos Aguirre | 77 | \$ 156,760.00 | 10/30/2017 -11/14/2017 | Rudy/Steve |
| Montclair | 909-625-9444 | Orchard Street | Steve Stanton | 77 | \$ 1,376,900.00 | 10/30/2017 - 1/26/2018 | Arturo |
| Pomona | 909-620-2261 | ADA Path of Travel Improvements | Matt Pilarz | 83 | \$ 734,205.00 | 2/5/2018 - 5/23/18 | Rudy |
| Santa Fe Springs | 562-868-0511 | Greenleaf Avenue Street Rehabilitation | Robert Garcia | 79 | \$ 989,155.00 | 1/2/2018 - 4/26/18 | Arturo |
| Covina | | Barranca Avenue Emergency Water | | 79 | \$ 164,187.00 | 6/13/2018 - 8/20/2018 | Gilbert |

DBE BIDDER'S LIST

All bidders/proposers are requested to provide the following information for all DBE and non-DBE contractors or consultants who provided a proposal, bid, quote, or were contacted by the proposed prime. This information is also requested from the proposed prime contractor/consultant and should be submitted with their bid/proposal. The City of La Habra will use this information to maintain and update a "Bidders" List to assist in the overall annual DBE goal-setting process.

| | | |
|--|---|--|
| Firm Name: _____ | Gentry Brothers Inc 384 Live Oak Ave Irwindale CA 91706 | Phone: <u>626-357-9631</u> |
| Address: _____ | | Fax: _____ |
| Contact Person: <u>Wayne Gentry</u> | | No. of years in business: <u>45</u> |
| Is the firm currently certified as a DBE under 49 CFR Part 26: YES: ___ NO: <input checked="" type="checkbox"/> | | |
| Type of work/services/materials provided by firm? <u>CONCRETE ASPHALT</u> <u>UNDERGROUND</u> | | |
| <hr/> <hr/> | | |
| What was your firm's Gross Annual receipts for last year? | | |
| Less than \$1 Million | | |
| Less than \$5 Million | | |
| Less than \$10 Million | | |
| Less than \$15 Million | | |
| More than \$15 Million <input checked="" type="checkbox"/> | | |

This form can be duplicated if necessary to report all bidders (DBEs and non-DBEs) information.

DBE BIDDER'S LIST

All bidders/proposers are requested to provide the following information for all DBE and non-DBE contractors or consultants who provided a proposal, bid, quote, or were contacted by the proposed prime. This information is also requested from the proposed prime contractor/consultant and should be submitted with their bid/proposal. The City of La Habra will use this information to maintain and update a "Bidders" List to assist in the overall annual DBE goal-setting process.

| | |
|---|--|
| Firm Name: <u>Superior Pavement Markings Inc.</u> | Phone: <u>(714) 995-9100</u> |
| Address: <u>5312 Cypress Street, Cypress CA 90630</u> | Fax: <u>(714) 995-9400</u> |
| Contact Person: <u>Raul Guzman, Estimator</u> | No. of years in business: <u>24</u> |
| Is the firm currently certified as a DBE under 49 CFR Part 26: YES: <input type="checkbox"/> NO: <input checked="" type="checkbox"/> | |
| Type of work/services/materials provided by firm? <u>Striping, Markings, Signage</u> | |
| <hr/> <hr/> What was your firm's Gross Annual receipts for last year? | |
| Less than \$1 Million | |
| Less than \$5 Million | |
| Less than \$10 Million | |
| Less than \$15 Million | |
| ✓ More than \$15 Million | |

This form can be duplicated if necessary to report all bidders (DBEs and non-DBEs) information.

DBE BIDDER'S LIST

All bidders/proposers are requested to provide the following information for all DBE and non-DBE contractors or consultants who provided a proposal, bid, quote, or were contacted by the proposed prime. This information is also requested from the proposed prime contractor/consultant and should be submitted with their bid/proposal. The City of La Habra will use this information to maintain and update a "Bidders" List to assist in the overall annual DBE goal-setting process.

| | |
|--|--|
| Firm Name: <u>California Professional Engineering, Inc.</u> Phone: <u>(626) 810-1338</u> | |
| Address: <u>19062 San Jose Ave La Puente, CA 91748</u> Fax: <u>(626) 810-1322</u> | |
| Contact Person: <u>Van Nguyen</u> | No. of years in business: <u>23</u> |
| Is the firm currently certified as a DBE under 49 CFR Part 26: YES: <input checked="" type="checkbox"/> NO: <input type="checkbox"/> #31277 | |
| Type of work/services/materials provided by firm? <u>Electrical Material and Installation</u> | |
| <hr/> | |
| What was your firm's Gross Annual receipts for last year? | |
| Less than \$1 Million | |
| Less than \$5 Million | |
| Less than \$10 Million | |
| Less than \$15 Million | |
| ✓ More than \$15 Million | |

This form can be duplicated if necessary to report all bidders (DBEs and non-DBEs) information.

VIOLATIONS OF FEDERAL, STATE, OR LOCAL LAWS

1. Has your firm or its officers been assessed any penalties by an agency for noncompliance or violations of Federal, State, or Local labor laws and/or business or licensing regulations within the past five (5) years relating to your construction projects?

Yes/No: NO Federal/State: _____

If "yes", identify and describe, (including agency and status):

Have the penalties been paid? Yes/No: _____

2. Does your firm or its officers have any ongoing investigations by any public agency regarding violations of the State Labor Code, California Business and Professions Code or State Licensing Laws?

Yes/No: NO Code/Laws: _____ Section/Article: _____

If "yes", identify and describe, (including agency and status):

DISQUALIFICATION OR DEBARMENT

Has your firm, any officer of your firm, or any employee who has a proprietary interest in your firm ever been disqualified, removed, or otherwise prevented from bidding on, performing work on, or completing a federal, state, or local project because of a violation of law or a safety regulation?

Yes/No: NO

If yes, provide the following information (if more than once, use separate sheets):

Date: _____ Entity: _____

Location: _____

Reason: _____

Provide Status and any Supplemental Statement: _____

Has your firm been reinstated by this entity?

Yes/No: No

LIST OF SUBCONTRACTORS

**MONTE VISTA STREET REHABILITATION PROJECT
FISCAL YEAR 2022-2023
CITY PROJECT NO. 2-R-22**

The bidder shall list below the name and the location of the place of business of each Subcontractor who will perform work or render services to the prime contractor in or about the construction of the work or improvement in excess of one-half of one percent (1/2%) of the prime contractor's total bid or ten thousand dollars (\$10,000.00) whichever is greater in accordance with the requirements of Section 4100 to 4133 inclusive of the public contracts code.

| <u>Work to be Performed</u> | <u>License Number</u> | <u>Subcontractor and Address of Office, Mill or Shops</u> | <u>Percent of Total Contract</u> | <u>DBE</u> | |
|-----------------------------|-----------------------|---|----------------------------------|------------|-----------|
| | | | | <u>YES</u> | <u>NO</u> |
| #S-STRIPING | 776306 | SUPERIOR 5312 GYRESS ST, GYRESS, CA | | | X |
| #23-LOOPS | 793907 | CPE 19062 SAN JOSE AVE, LA PUENTE, CA | | X | |
| | | | | | |
| | | | | | |
| | | | | | |
| | | | | | |
| | | | | | |
| | | | | | |

SUBS

Note: Do not list alternative subcontractors for the same work.

Contractor GENTRY BROTHERS INC

BID BOND

KNOW ALL MEN BY THESE PRESENTS:

That we Gentry Brothers, Inc. as principal and Federal Insurance Company as surety, are held and firmly bound unto the City of La Habra, California hereinafter referred to as "Owner", in the sum of Ten percent of the total bid amount Dollars (\$ 10%) to be paid to the said Owner, its successors and assigns for which payment well and truly to be made we bind ourselves, our heirs, executors, administrators, successors and assigns, jointly and severally, firmly by these presents.

THE CONDITION OF THIS OBLIGATION IS SUCH that if the certain proposal of the above bounden for the construction of Street Improvements as specifically set forth in documents entitled:

**MONTE VISTA STREET REHABILITATION PROJECT
FISCAL YEAR 2022-2023
CITY PROJECT NO. 2-R-22**

all in accordance with the specifications and drawings on file at the offices of the City Clerk of the City of La Habra, California and is not withdrawn within the period of sixty (60) days after the date set for the opening of bids unless otherwise required by law and notwithstanding the award of the Contract to another bidder and that if said proposal is accepted by the Owner through action of its legally constituted contracting authorities and if the above bounden his heirs, executors, administrators, successors and assigns shall duly enter into and execute a contract for such construction and shall execute and deliver the required Performance and Payment Bonds and proof of insurance coverage within ten (10) days (not including Saturdays, Sundays and Holidays) after the date of notification by and from the said Owner that the said contract is ready for execution, then this obligation shall become null and void; otherwise, it shall be and remain in full force and vi

Bon

IN WITNESS WHEREOF, we hereunto set hands and seal this 16th

day of April, 2024.

Federal Insurance Company

Ryan Butterfas, Attorney-in-Fact

SURETY

Gentry Brothers, Inc.

BIDDER

NOTE: The standard printed bond form of any bonding company acceptable to the Owner may be used in lieu of the foregoing approved sample bond form provided the security stipulations protecting the Owner are not in any way reduced by use of the Surety Company's printed standard form.

CALIFORNIA ALL-PURPOSE ACKNOWLEDGMENT

CIVIL CODE § 1189

A notary public or other officer completing this certificate verifies only the identity of the individual who signed the document to which this certificate is attached, and not the truthfulness, accuracy, or validity of that document.

State of California)
County of Orange)

On APR 16 2024 before me, Adelaide C. Hunter, Notary Public,
Date Here Insert Name and Title of the Officer
personally appeared Ryan Butterfas
Name(s) of Signer(s)

who proved to me on the basis of satisfactory evidence to be the person(s) whose name(s) is/are subscribed to the within instrument and acknowledged to me that he/she/they executed the same in his/her/their authorized capacity(ies), and that by his/her/their signature(s) on the instrument the person(s), or the entity upon behalf of which the person(s) acted, executed the instrument.

I certify under PENALTY OF PERJURY under the laws of the State of California that the foregoing paragraph is true and correct.

WITNESS my hand and official seal.



Signature A. Hunter
Signature of Notary Public

Place Notary Seal Above

OPTIONAL

Though this section is optional, completing this information can deter alteration of the document or fraudulent reattachment of this form to an unintended document.

Description of Attached Document

Title or Type of Document: _____ Document Date: _____
Number of Pages: _____ Signer(s) Other Than Named Above: _____

Capacity(ies) Claimed by Signer(s)

Signer's Name: _____
 Corporate Officer — Title(s): _____
 Partner — Limited General
 Individual Attorney in Fact
 Trustee Guardian or Conservator
 Other: _____
Signer Is Representing: _____

Signer's Name: _____
 Corporate Officer — Title(s): _____
 Partner — Limited General
 Individual Attorney in Fact
 Trustee Guardian or Conservator
 Other: _____
Signer Is Representing: _____

CHUBB

Power of Attorney

Federal Insurance Company | Vigilant Insurance Company | Pacific Indemnity Company
Westchester Fire Insurance Company | ACE American Insurance Company

Know All by These Presents, that FEDERAL INSURANCE COMPANY, an Indiana corporation, VIGILANT INSURANCE COMPANY, a New York corporation, PACIFIC INDEMNITY COMPANY, a Wisconsin corporation, WESTCHESTER FIRE INSURANCE COMPANY and ACE AMERICAN INSURANCE COMPANY corporations of the Commonwealth of Pennsylvania, do each hereby constitute and appoint Ryan Butterfas, Linda D. Coats, Matthew J. Coats and Summer Reyes of Laguna Hills, California-----

each as their true and lawful Attorney-in-Fact to execute under such designation in their names and to affix their corporate seals to and deliver for and on their behalf as surety thereon or otherwise, bonds and undertakings and other writings obligatory in the nature thereof (other than bail bonds) given or executed in the course of business, and any instruments amending or altering the same, and consents to the modification or alteration of any instrument referred to in said bonds or obligations.

In Witness Whereof, said FEDERAL INSURANCE COMPANY, VIGILANT INSURANCE COMPANY, PACIFIC INDEMNITY COMPANY, WESTCHESTER FIRE INSURANCE COMPANY and ACE AMERICAN INSURANCE COMPANY have each executed and attested these presents and affixed their corporate seals on this 18th day of November, 2021.

Dawn M. Chloros

Dawn M. Chloros, Assistant Secretary

Stephen M. Haney

Stephen M. Haney, Vice President



STATE OF NEW JERSEY
County of Hunterdon ss.

On this 18th day of November, 2021 before me, a Notary Public of New Jersey, personally came Dawn M. Chloros and Stephen M. Haney, to me known to be Assistant Secretary and Vice President, respectively, of FEDERAL INSURANCE COMPANY, VIGILANT INSURANCE COMPANY, PACIFIC INDEMNITY COMPANY, WESTCHESTER FIRE INSURANCE COMPANY and ACE AMERICAN INSURANCE COMPANY, the companies which executed the foregoing Power of Attorney, and the said Dawn M. Chloros and Stephen M. Haney, being by me duly sworn, severally and each for herself and himself did depose and say that they are Assistant Secretary and Vice President, respectively, of FEDERAL INSURANCE COMPANY, VIGILANT INSURANCE COMPANY, PACIFIC INDEMNITY COMPANY, WESTCHESTER FIRE INSURANCE COMPANY and ACE AMERICAN INSURANCE COMPANY and know the corporate seals thereof, that the seals affixed to the foregoing Power of Attorney are such corporate seals and were thereto affixed by authority of said Companies; and that their signatures as such officers were duly affixed and subscribed by like authority.

Notarial Seal



KATHERINE J. ADELAAR
NOTARY PUBLIC OF NEW JERSEY
No. 2316685
Commission Expires July 18, 2024

Katherine J. Adelaar
Notary Public

CERTIFICATION

Resolutions adopted by the Boards of Directors of FEDERAL INSURANCE COMPANY, VIGILANT INSURANCE COMPANY, and PACIFIC INDEMNITY COMPANY on August 30, 2016; WESTCHESTER FIRE INSURANCE COMPANY on December 11, 2006; and ACE AMERICAN INSURANCE COMPANY on March 20, 2009:

"RESOLVED, that the following authorizations relate to the execution, for and on behalf of the Company, of bonds, undertakings, recognizances, contracts and other written commitments of the Company entered into in the ordinary course of business (each a "Written Commitment"):

- (1) Each of the Chairman, the President and the Vice Presidents of the Company is hereby authorized to execute any Written Commitment for and on behalf of the Company, under the seal of the Company or otherwise.
- (2) Each duly appointed attorney-in-fact of the Company is hereby authorized to execute any Written Commitment for and on behalf of the Company, under the seal of the Company or otherwise, to the extent that such action is authorized by the grant of powers provided for in such person's written appointment as such attorney-in-fact.
- (3) Each of the Chairman, the President and the Vice Presidents of the Company is hereby authorized, for and on behalf of the Company, to appoint in writing any person the attorney-in-fact of the Company with full power and authority to execute, for and on behalf of the Company, under the seal of the Company or otherwise, such Written Commitments of the Company as may be specified in such written appointment, which specification may be by general type or class of Written Commitments or by specification of one or more particular Written Commitments.
- (4) Each of the Chairman, the President and the Vice Presidents of the Company is hereby authorized, for and on behalf of the Company, to delegate in writing to any other officer of the Company the authority to execute, for and on behalf of the Company, under the Company's seal or otherwise, such Written Commitments of the Company as are specified in such written delegation, which specification may be by general type or class of Written Commitments or by specification of one or more particular Written Commitments.
- (5) The signature of any officer or other person executing any Written Commitment or appointment or delegation pursuant to this Resolution, and the seal of the Company, may be affixed by facsimile on such Written Commitment or written appointment or delegation.

FURTHER RESOLVED, that the foregoing Resolution shall not be deemed to be an exclusive statement of the powers and authority of officers, employees and other persons to act for and on behalf of the Company, and such Resolution shall not limit or otherwise affect the exercise of any such power or authority otherwise validly granted or vested."

I, Dawn M. Chloros, Assistant Secretary of FEDERAL INSURANCE COMPANY, VIGILANT INSURANCE COMPANY, PACIFIC INDEMNITY COMPANY, WESTCHESTER FIRE INSURANCE COMPANY and ACE AMERICAN INSURANCE COMPANY (the "Companies") do hereby certify that

- (i) the foregoing Resolutions adopted by the Board of Directors of the Companies are true, correct and in full force and effect,
- (ii) the foregoing Power of Attorney is true, correct and in full force and effect.

Given under my hand and seals of said Companies at Whitehouse Station, NJ, this 16th day of April, 2024.



Dawn M. Chloros

Dawn M. Chloros, Assistant Secretary

IN THE EVENT YOU WISH TO VERIFY THE AUTHENTICITY OF THIS BOND OR NOTIFY US OF ANY OTHER MATTER, PLEASE CONTACT US AT:
Telephone (908) 903-3493 Fax (908) 903-3656 e-mail: surety@chubb.com

California Acknowledgment Form

A notary public or other officer completing this certificate verifies only the identity of the individual who signed the document to which this certificate is attached, and not the truthfulness, accuracy, or validity of that document.

State of California }
County of Los Angeles } ss.

On April 23, 2024 before me, N. Smith, Notary,
(here insert name and title of the officer)
personally appeared Wayne J. Gentry

who proved to me on the basis of satisfactory evidence to be the person ~~(s)~~ whose name ~~(s)~~ is/are subscribed to the within instrument and acknowledged to me that he ~~/she/it~~ executed the same in his ~~/her/its~~ authorized capacity ~~(ies)~~, and that by his signature ~~(s)~~ on the instrument the person ~~(s)~~, ~~X~~ or the entity upon behalf of which the person ~~(s)~~ acted, executed the instrument.

I certify under PENALTY OF PERJURY under the laws of the State of California that the foregoing paragraph is true and correct.

Seal

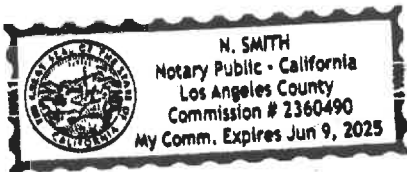

WITNESS my hand and official seal.

Signature of Notary

Optional Information

To help prevent fraud, it is recommended that you provide information about the attached document below.
This is not required under California State notary public law.

Document Title: Bid Bond # of Pages: 1

Notes

City of La Habra - Monte Vista Street Rehabilitation

NON-COLLUSION AFFIDAVIT
FOR

MONTE VISTA STREET REHABILITATION PROJECT
FISCAL YEAR 2022-2023
CITY PROJECT NO. 2-R-22

(TO BE EXECUTED BY EACH AWARDEE OF A PRINCIPAL CONTRACT)

STATE OF CALIFORNIA)
) SS.
)

_____ WAYNE GENTRY _____, being first duly sworn,
deposes and says that he is SEC, TRS
(sole owner, partner, president, secretary, etc.)

of GENTRY BROTHERS INC

The party making the foregoing bid; that such bid is not made in the interest of or on behalf of any undisclosed person, partnership, company, association, organization or corporation; that such bid is genuine and not collusive or sham: that said bidder has not directly or indirectly induced or solicited any other bidder to put in a false or sham bid, and has not directly or indirectly colluded, conspired, connived, or agreed with any bidder or anyone else to put in a sham bid, nor that anyone shall refrain from bidding; that said bidder has not in any manner directly or indirectly sought by agreement, communication or conference with anyone to fix the bid price of said bidder or of any other bidder, nor to fix any overhead, profit cost element of such bid price nor of that of any other bidder nor to secure any advantage against the public body awarding the contract or anyone interested in the proposed contract; that all statements contained in such bid are true; and, further, that said bidder has not directly or indirectly, submitted his bid price or any breakdown thereof, nor the contents thereof, nor divulged information or data relative thereto, nor paid and will not pay any fee in connection therewith to any corporation, partnership, company, association, organization, bid depository, nor to any member of agent thereof nor to any other individual except to such person or persons as have a partnership or other financial interest with said bidder in his general business.

Signed: _____
Title: SEC, TRS

Subscribed and sworn to before me

This _____ day of _____, 2024

SEAL OF NOTARY PUBLIC

California Acknowledgment Form

A notary public or other officer completing this certificate verifies only the identity of the individual who signed the document to which this certificate is attached, and not the truthfulness, accuracy, or validity of that document.

State of California }
County of Los Angeles } ss.

On April 23, 2024 before me, N. Smith, Notary,
(here insert name and title of the officer)
personally appeared Wayne J. Gentry

who proved to me on the basis of satisfactory evidence to be the person(s) whose name(s) is/are subscribed to the within instrument and acknowledged to me that he/~~she/it~~ executed the same in his/~~her/their~~ authorized capacity(ies), and that by his signature(s) on the instrument the person(s), or the entity upon behalf of which the person(s) acted, executed the instrument.

I certify under PENALTY OF PERJURY under the laws of the State of California that the foregoing paragraph is true and correct.

Seal

WITNESS my hand and official seal.



Signature of Notary

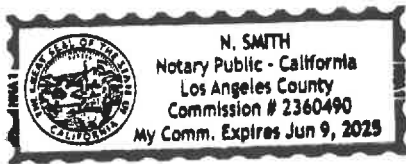

Optional Information

To help prevent fraud, it is recommended that you provide information about the attached document below.
This is not required under California State notary public law.

Document Title: Non-Collusion Affidavit # of Pages: 1

Notes

City of La Habra - Monte Vista Street Rehabilitation

WORKER'S COMPENSATION CERTIFICATE

(AS REQUIRED BY SECTION 1861
OF THE CALIFORNIA LABOR CODE)

I am aware of the provisions of Section 3700 of the California Labor Code, which require every employer to be insured against liability for worker's compensation, or to undertake self-insurance in accordance with the provisions of said Code, and I will comply with such provisions before commencing the performance of the Work of this Contract.

Contractor GENTRY BROTHERS INC
By *Ray*
Title *SEC, TREAS*

Public Contract Code Section 10285.1 Statement

In conformance with Public Contract Code Section 10285.1 (Chapter 376, Stats. 1985), the bidder hereby declares under penalty of perjury under the laws of the State of California that the bidder **has** ____, **has not** been convicted within the preceding three years of any offenses referred to in that section, including any charge of fraud, bribery, collusion, conspiracy, or any other act in violation of any state or Federal antitrust law in connection with the bidding upon, award of, or performance of, any public works contract, as defined in Public Contract Code Section 1101, with any public entity, as defined in Public Contract Code Section 1100, including the Regents of the University of California or the Trustees of the California State University. The term "bidder" is understood to include any partner, member, officer, director, responsible managing officer, or responsible managing employee thereof, as referred to in Section 10285.1.

Note: The bidder must place a check mark after "has" or "has not" in one of the blank spaces provided. The above Statement is part of the Proposal. Signing this Proposal on the signature portion thereof shall also constitute signature of this Statement. Bidders are cautioned that making a false certification may subject the certifier to criminal prosecution.

Public Contract Code Section 10162 Questionnaire

In conformance with Public Contract Code Section 10162, the Bidder shall complete, under penalty of perjury, the following questionnaire:

Has the bidder, any officer of the bidder, or any employee of the bidder who has a proprietary interest in the bidder, ever been disqualified, removed, or otherwise prevented from bidding on, or completing a federal, state, or local government project because of a violation of law or a safety regulation?

Yes _____ No

If the answer is yes, explain the circumstances in the following space.

Public Contract Code Section 10232 Statement

In conformance with Public Contract Code Section 10232, the Contractor, hereby states under penalty of perjury, that no more than one final unappealable finding of contempt of court by a federal court has been issued against the Contractor within the immediately preceding two year period because of the Contractor's failure to comply with an order of a federal court which orders the Contractor to comply with an order of the National Labor Relations Board.

Note: The above Statement and Questionnaire are part of the Proposal. Signing this Proposal on the signature portion thereof shall also constitute signature of this Statement and Questionnaire.

Bidders are cautioned that making a false certification may subject the certifier to criminal prosecution.

**CITY OF LA HABRA
PUBLIC WORKS DEPARTMENT
ENGINEERING DIVISION**



110 E. LA HABRA BOULEVARD
LA HABRA, CA 90631
(562) 383-4151

SPECIFICATIONS FOR

**MONTE VISTA STREET REHABILITATION PROJECT
FISCAL YEAR 2022-2023
CITY PROJECT NO. 2-R-22**

| | | |
|----------------|------------------------------|-----------------|
| CITY MANAGER | | JIM SADRO |
| | <u>LA HABRA CITY COUNCIL</u> | |
| MAYOR | | DAREN NIGSARIAN |
| MAYOR PRO TEM | | ROSE ESPINOZA |
| COUNCIL MEMBER | | JOSE MEDRANO |
| COUNCIL MEMBER | | JAMEZ GOMEZ |
| COUNCIL MEMBER | | STEVE SIMONIAN |

BID OPENING: Wednesday, April 24th, 2024 at 3PM

PLANS AND SPECIFICATIONS:
PICKED UP: \$25.00
MAILED: \$45.00

**CITY OF LA HABRA
PUBLIC WORKS DEPARTMENT
ENGINEERING DIVISION**



110 E. LA HABRA BOULEVARD
LA HABRA, CA 90631
(562) 383-4151

**SPECIFICATIONS FOR
MONTE VISTA STREET REHABILITATION PROJECT
FISCAL YEAR 2022-2023
CITY PROJECT NO. 2-R-22**

March 2024
Plans and Specifications

APPROVED BY:

A handwritten signature in blue ink, appearing to read 'Albert Mendoza', is positioned above a horizontal line.

**ALBERT MENDOZA, P.E.
DEPUTY DIRECTOR OF PUBLIC WORKS/CITY ENGINEER**

TABLE OF CONTENTS

| | |
|---|------|
| <u>NOTICE INVITING BIDS</u> | A-1 |
| <u>INSTRUCTION TO BIDDERS</u> | B-1 |
| <u>SPECIAL PROVISIONS</u> | C-1 |
| SECTION 1. DEFINITION OF TERMS | C-2 |
| SECTION 2. REQUIREMENTS AND CONDITIONS | C-3 |
| SECTION 3. SCOPE OF WORK | C-8 |
| SECTION 4. CONTROL OF THE WORK | C-8 |
| SECTION 5. CONTROL OF MATERIAL | C-13 |
| SECTION 6. LEGAL RELATIONS AND RESPONSIBILITIES | C-15 |
| SECTION 7. PROSECUTION AND PROGRESS | C-24 |
| SECTION 8. PAYMENTS | C-25 |
| SECTION 9. WORK SCHEDULES | C-26 |
| SECTION 10. CITY REQUIREMENTS | C-26 |
| SECTION 11. CONSTRUCTION DETAILS | C-29 |
| SECTION 12. BID ITEMS FOR MONTE VISTA REHABILITATION PROJECT | C-38 |
| <u>PROPOSAL</u> | D-1 |
| PROPOSAL | D-2 |
| BIDDER'S INFORMATION | D-5 |
| BID SCHEDULE | D-6 |
| ACKNOWLEDGEMENT OF ADDENDA RECEIVED | D-9 |
| REFERENCES | D-10 |
| DBE BIDDER'S LIST | D-12 |
| VIOLATIONS OF FEDERAL, STATE, OR LOCAL LAWS | D-13 |
| DISQUALIFICATION OR DEBARMENT | D-14 |
| LIST OF SUBCONTRACTORS | D-15 |
| BID SECURITY FORM | D-16 |
| BID BOND | D-17 |
| NON-COLLUSION AFFIDAVIT | D-18 |
| WORKER'S COMPENSATION CERTIFICATE | D-19 |
| PUBLIC CONTRACT CODE SECTION 10285.1 STATEMENT | D-20 |
| PUBLIC CONTRACT CODE SECTION 10162 QUESTIONNAIRE | D-21 |
| PUBLIC CONTRACT CODE SECTION 10232 STATEMENT | D-22 |
| <u>SAMPLE AGREEMENT</u> | E-1 |
| 1.0 DEFINITIONS | E-2 |
| 2.0 SERVICES OF CONTRACTOR | E-3 |
| 3.0 COMPENSATION | E-5 |
| 4.0 PERFORMANCE SCHEDULE | E-5 |
| 5.0 COORDINATION OF WORK | E-6 |
| 6.0 INSURANCE, INDEMNIFICATION AND BONDS | E-8 |
| 7.0 RECORDS AND REPORTS | E-10 |
| 8.0 GENERAL PROVISIONS | E-11 |
| LABOR AND MATERIAL PAYMENT BOND | E-18 |

| | |
|--|------|
| FAITHFUL PERFORMANCE BOND | E-20 |
| SUPPLEMENTAL INFORMATION TO BE COMPLETED BY PRINCIPAL | E-22 |
| TAX IDENTIFICATION NUMBER | E-23 |
| BID GUARANTEE | E-24 |
| STATEMENT OF NON-COLLUSION BY CONTRACTOR | E-25 |
| CERTIFICATION OF COMPLIANCE | E-26 |
| EXHIBIT A – SCOPE OF SERVICES | E-27 |
| EXHIBIT B – INSURANCE REQUIREMENTS | E-28 |
| EXHIBIT C – CERTIFICATES OF INSURANCE AND ENDORSEMENTS | E-31 |
| EXHIBIT D – CLAIMS PROCEDURE | E-32 |
| | |
| APPENDIX “A”, PLANS | |
| APPENDIX “B”, STANDARD PLANS | |
| APPENDIX “C”, RAILROAD ENCHROACHMENT PERMIT | |
| APPENDIX “D”, UTILITY REQUIREMENTS | |

SECTION A

NOTICE INVITING BIDS

CITY OF LA HABRA

NOTICE INVITING BIDS

NOTICE IS HEREBY GIVEN that sealed bids will be received by the City Clerk of the City of La Habra, California for furnishing all labor, services, materials, tools, equipment, supplies, transportation, utilities and all other items and facilities necessary therefor as provided in the Contract Documents for the: **MONTE VISTA STREET REHABILITATION PROJECT, FISCAL YEAR 2022-2023 CITY PROJECT NO. 2-R-22** in strict compliance with the specifications, plans and contract documents on file at the Office of the City Clerk of the City of La Habra.

DATE OF OPENING BIDS: Bids will be received at the Office of the City Clerk of the City of La Habra until **3:00 PM on April 24, 2024**, at which time and place the bids will be publicly opened and read aloud. Bids shall be submitted in sealed envelopes marked on the outside: **“MONTE VISTA STREET REHABILITATION PROJECT, FISCAL YEAR 2022-2023, CITY PROJECT NO. 2-R-22. DO NOT OPEN WITH REGULAR MAIL.”**

LOCATION OF WORK: The work to be constructed hereunder is shown construction plans attached as APPENDIX “A”.

DESCRIPTION OF WORK: The work comprises the furnishing of all materials, equipment, tools, labor and incidentals as required by the Plans, Specifications and Contract Documents for the above stated project. The general items of work to be performed hereunder consist of but not be limited to **Mobilization/Demobilization; Traffic Control, Safety and Cleanup; Construction Staking and Monument Perpetuation; Storm Water Best Management Practices (BMPs); Unclassified Excavation and Disposal; Coldmill and Dispose of Existing Asphalt; Adjust to Grade Manhole Covers, Water Valves; Sawcut and Remove Existing and Construct Curb Ramp with Detectable Warning Surface; Sawcut and Remove Existing and Construct Concrete Curb and Gutter and Cross Gutter over CMB with AC Slot Trench; Construct AC Base Paving; Construct Rubberized AC pavement Overlay; Traffic Striping, Crosswalks, Curb Painting, Markings, and Raised Pavement Markers; Traffic Signal Loop Detectors; and all incidental work so indicated on the specifications, and required for the proposed improvements.**

CONTRACTOR’S LICENSE: The City of La Habra has determined that a Class “A” Contractor’s License is required for this project.

COMPLETION OF WORK: All work shall be completed within Fifty-five (55) working days from the start date specified in the Notice To Proceed.

LIQUIDATED DAMAGE: If the total amount of working days have expired and the work is not complete, liquidated damages are One Thousand Five Hundred Dollars (\$1,500) per calendar day.

AWARD OF CONTRACT: The City of La Habra reserves the right, after opening the bids, to reject any or all bids, waive any informality or irregularity in such bids, or to award to the lowest responsible bidder and reject all other bids.

PROPOSAL GUARANTEE AND BONDS: Each bid must be accompanied by a certified cashier's check or by a corporate surety bond on the form furnished by the City of La Habra, as guarantee that the bidder will, if an award is made to him in accordance with the terms of his bid, promptly secure Worker's Compensation Insurance and Liability Insurance, execute the contract in the required form and furnish satisfactory bonds for the faithful performance of the contract and for the payment of claims of materialmen and workers thereunder. Said check or bidder's bond shall be in an amount of not less than ten percent (10%) of the amount of the bid. The Faithful Performance Bond shall be not less than one hundred percent (100%) of the total amount of the bid price named in the contract. The Payment Bond shall be not less than one hundred percent (100%) of the total amount of the bid price named in the contract. The City of La Habra reserves the right to reject any bond if, in the opinion of the Engineer, the Surety's acknowledgment is not in the form included in the contract documents or in another form substantially as prescribed by law.

PREVAILING RATES OF WAGES: Pursuant to the provisions of Section 1773 of the Labor Code of the State of California, the Director of Industrial Relations has ascertained the general prevailing rate of wages and employer payments for health and welfare, vacation, pension and similar purposes applicable to the work to be done. A copy of said wage rates is available on-line at:

<https://www.dir.ca.gov/dlsr/DPreWageDetermination.htm>

The Contractor and all subcontractors are responsible to pay the prevailing rates of wages that are specified within ten (10) calendar days before the bid open day and shall post a copy of said wage rates at the project site. The statutory provisions for penalties for failure to pay prevailing wages will be enforced (Labor Code §1775) and the statutory provisions for failure to comply with the States' wage and hour laws will be enforced (Labor Code §1813).

DEBARMENT: No Contractor or Subcontractor may be awarded as a contractor on a bid proposal if they have been Debarred by the State pursuant to Labor Code Sections 1777.1 and 1777.7 and Public Contracts Code Section 6109.

APPRENTICE: The Contractor shall comply with all laws, rules, regulations, and all the requirements of the Labor Code including, but not limited to, Section 1776, 1777.5, and 1777.6 of the California Labor Code.

CONTRACT DOCUMENTS: The Contract Documents shall consist of the following: Notice Inviting Bids; Instructions to Bidders; Proposal; Bidder's Information; Bid Schedule; Acknowledgement of Addenda Received; References; DBE Bidder's List; Violations of Federal, State, or Local Laws; Disqualification or Debarment; List of Subcontractors; Bid Security Form; Bid Bond; Non-Collusion Affidavit; Worker's Compensation Certificate; Public Contract Code Section 10285.1 Statement; Public Contract Code Section 10162 Questionnaire; Public Contract

Code Section 10232 Statement; Agreement; Labor and Material Payment Bond; Faithful Performance Bond; Supplemental Information to be Completed By Principal; Tax Identification Number; Bid Guarantee; Statement of Non-Collusion By Contractor, Certification of Compliance; Special Provisions; Drawings; and the Standard Specifications for Public Works Construction, latest edition and supplements thereto, made a part by reference, together with all additions, deletions, modifications or interpretations of any of said documents, all of which are hereby made a part of this Notice Inviting Bids.

Specifications are available for inspection, without charge, at the Office of the City Engineer of the City of La Habra.

Complete sets of said plans, specifications, and bid documents may be purchased at twenty-five dollars (**\$25.00**) per set and are obtainable from the City Engineer of the City of La Habra, 110 E. La Habra Blvd, La Habra, California. An additional twenty dollars (**\$20.00**) shall be charged for requests by mail. No refund shall be made for sets of said plans, specifications, and bid documents returned.

ADDRESS AND MARKING OF PROPOSAL: The envelope enclosing the proposal shall be sealed and addressed to the City Clerk and hand delivered to the City Clerk at the Civic Center, 110 E. La Habra Blvd (Administration Department), or mailed to City Clerk, Civic Center, 110 E. La Habra Blvd, La Habra, California 90631. The envelope shall be plainly marked in the upper left-hand corner with the name and address of the bidder and shall bear the words "Proposal For" followed by the title of the specifications for the work, and the date and hour of opening bids. The certified or cashier's check, money order, or bidder's bond shall be enclosed in the same envelope with the proposal.

BID PROTEST: The filing of bid protest to all our project specifications:

Bidders may file a "protest" of a Bid with the City Clerk. In order for a Bidder's protest to be considered valid, the protest must:

- 1) Be filed in writing seven (7) calendar days after the bid opening date;
- 2) Clearly identify the specific irregularity or accusation;
- 3) Specify, in detail, the grounds of the protest and the facts supporting the protest; and
- 4) Include all relevant, supporting documentation with the protest at the time of filing.

If the protest does not comply with each of these requirements, it will be rejected as invalid. Should the protest deems to be valid, the Engineering Division shall review the basis of the protest and all relevant information. The Public Works Director or designee will provide a written response to the protestor. Should there may be any appeal to the decision made by the City, the protester can file an appeal letter to the City Manager.

DEPARTMENT OF INDUSTRIAL RELATIONS (DIR) REQUIREMENT: No Contractor or Subcontractor may be listed on a bid proposal for a public works project unless registered with the Department of Industrial Relations (DIR) pursuant to Labor Code 1725.5 and Senate Bill 854.

Payroll documents for the contractor and subcontractors should be submitted and registered on time with the DIR.

Under California Labor Code Section 1771.1, in order to be awarded and to perform work on public works projects, prime contractors and subcontractors must possess and maintain registration with the Department of Industrial Relations (DIR) at <https://www.dir.ca.gov/public-works/contractor-registration.html>. This is a separate requirement from the Contractors State License Board (CSLB) licensing requirement. See the Special Provisions for additional details.

SUBMISSION OF QUESTIONS:

- Questions received after Wednesday, April 3rd, 5:00 PM may not be considered.
- Questions or clarifications deemed by the City to be material change will be answered via issuance of an addendum and posted to the City’s online bidding service, CIPlist.com.
- Only questions answered by formal written addenda shall be binding. Oral and other interpretations or clarifications shall be without legal effect. It is the Bidder’s responsibility to be informed of any issued addenda and to include all such information in its Bid.
- Any questions regarding this solicitation shall be submitted electronically to Andrew Luna at anluna@lahabra.ca.gov.

BID SCHEDULE:

Bid AdvertisementThursday, March 21, 2024
Requests for Informationdue by Wednesday, April 3, 2024, 5:00 pm
Response to Requested for Information.....Thursday, April 11, 2024, 3:00 pm
Bid Openingdue by Wednesday, April 24, 2024, 3:00 pm

SECTION B
INSTRUCTIONS TO BIDDERS

CITY OF LA HABRA

INSTRUCTIONS TO BIDDERS

The following instructions and conditions apply to the attached bid and the bidder acknowledges the acceptance thereof by signing and filing said bid.

Each bidder shall state whether he is an individual, firm or corporation; if firm, give name of each member; if a corporation, give name of president, secretary, treasurer and manager.

Proposals shall be submitted to the City of La Habra on forms prepared and furnished in the bid documents, or as provided by the Engineering Office of the City of La Habra. When presented, they must be completely made out in the manner and form indicated therein, showing the proposed prices clearly and legibly and must be properly signed by the bidder. Proposals presented otherwise may be rejected.

Each proposal so submitted, together with the required proposal guarantee hereinafter prescribed, shall be presented under sealed cover and must be filed prior to the time and place designated in the Notice Inviting Bids. A proposal so presented, however, may be withdrawn by the bidder provided the request therefor is made in writing, is signed by the bidder or his authorized representative and is filed prior to the time fixed for the opening of bids. The withdrawal of a bid proposal does not prejudice the right of the bidder to file a new bid.

All proposals submitted as hereinabove prescribed will be publicly opened and read at the time and place indicated in the Notice Inviting Bids.

Bids are required for the entire work. The amount of the bid for comparison purposes will be the total of all items.

The bidder shall set forth for each item of work, in words and in clearly legible figures, a unit price and an amount for the item in the respective space provided for this purpose. In the case of unit price items, the amount set forth under the "AMOUNT" column shall be the extension of the unit price bid on the basis of the estimated quantity for the item. In case of discrepancy between the words and figures, the words shall prevail.

In case of discrepancy between the "Unit Price" and the "Amount" set forth for the item, the Unit Price shall prevail. However, if the amount set forth as a Unit Price is ambiguous, unintelligible or uncertain for any cause or is omitted or in the case where the Unit Price is the same amount as the entry in the "AMOUNT" column for the item, the "AMOUNT" price shall prevail in accordance with the following:

- (1) As to lump sum items, the amount set forth in the "AMOUNT" column shall be the unit price.
- (2) As to unit price items, the amount set forth in the "AMOUNT" column shall be divided by the estimated quantity for the item and the price thus obtained shall be the unit price.

In case of discrepancy between the sum of the individual “AMOUNT” prices, and the Total Bid Price, the sum of the individual “AMOUNT” prices will prevail.

In case of discrepancy of the Mobilization and Demobilization “Unit Price” and “Amount” being higher than Five percent (5%) of the total bid amount as stated in the contract document, then the “Unit Price” and “Amount” shall be deemed to be Five percent (5%) of the total bid amount.

Bidders must satisfy themselves by personal examination of the location of the proposed work and by personal examination of the proposed contract documents as to the actual conditions and the requirements of this work and shall not at any time after submission of the bid dispute, complain or assert that there was any misunderstanding in regard to the nature or the amount of work to be done unless a written change in these specifications or contract or written clarification thereof has been issued by the City of La Habra.

Each bid must be in a sealed envelope which is to be clearly marked so as to identify it as a bid (such as “Sealed Bid - do not open with regular mail”), giving the number and name of the project or specification and the name of the bidder. These instructions are particularly necessary if your bid is transmitted by mail. Failure to identify the project or to address it to the City Clerk, Civic Center, 110 E. La Habra Blvd, La Habra, California 90631, Attention City Clerk, will result in the opening of the envelopes with the regular mail and may thereby void the bid.

The City Council will award the contract to the lowest responsible bidder, however, said Council reserves the right to reject any or all bids, to waive any informality in the bids received and, if necessary, to take said bids under advisement for a period not to exceed ninety (90) days including lead-time.

All proposal requirements and conditions as set forth in the Standard Specifications shall apply hereto.

APPROXIMATE ESTIMATE: The quantities shown in the proposal form and in the estimate included in the bid documents shall be considered as approximate only, being listed therein for the purpose of serving as a general indication of the amount of work or materials to be performed or furnished as a basis for the comparison of bids. The Council does not guarantee nor agree, either expressly or by implication, that the actual amounts required will correspond therewith, but reserves the right to increase or decrease the amount of any item, portion of work to be performed or material to be furnished, or to omit any such item or portion, in accordance with the provisions relative thereto set forth in the bid documents or Standard Specifications under which the work is to be constructed, without in any way invalidating the contract should such increase, decrease or omission be deemed necessary or expedient. The City of La Habra reserves the right to increase or decrease the amount of any item as necessary due to budgetary requirements.

DISADVANTAGED BUSINESS ENTERPRISE (DBE) REQUIREMENTS: The City of La Habra requires that Disadvantaged Business Enterprises (DBEs) have the opportunity to participate in public works projects. To assist the City of La Habra in establishing future Annual Anticipated DBE Participation Level (AADPL), all contractors are required to submit a list of all subcontractors and suppliers, whether DBE or not, contacted during preparation of the bid.

SECTION C

SPECIAL PROVISIONS

SPECIAL PROVISIONS

SECTION 1. DEFINITION OF TERMS

CITY: The City of La Habra

CITY COUNCIL: The City Council of the City of La Habra.

ENGINEER: Any reference to the “Engineer” in the specifications shall be construed to mean the City Engineer of the City of La Habra or his authorized agents.

BIDDER: Any individual, firm or corporation submitting a bid to furnish the materials and equipment and perform the work herein specified, properly made out on the form furnished by the City Engineer, duly executed by the bidder and enclosed within a sealed envelope directed to the City Clerk, Civic Center, 110 E. La Habra Blvd., La Habra, California 90631.

BID FORMS: The blank forms prepared by the City of La Habra on which the bidder must submit the bid.

CONTRACTOR: The bidder whose bid is accepted and to whom the contract is awarded.

CONTRACT: The Specifications, Special Provisions, the notice inviting bids, the bid and addenda of the Contract, and the agreement entered into pursuant thereto shall constitute the Contract between the City of La Habra and the Contractor.

LABORATORY: The designated laboratory authorized by the Engineer to test materials and work involved in the contract.

THE WORK: All the work required to be performed under the contract.

GENERAL CONSTRUCTION TERMS: Unless otherwise specifically defined herein or unless the content requires a different meaning, all words, terms and phrases having a well-known or technical meaning shall be so construed.

USE OF PRONOUNS: Words used herein in the masculine gender include the feminine and neuter and vice versa; the singular number includes the plural and the plural the singular. The word “person” includes a corporation, association or partnership.

SECTION: The part into which these Special Provisions are divided. Each section is designated by a whole number preceding its title.

ARTICLES: The parts into which sections are divided. Each article is designated by a number preceding its title, the first two figures to the right of the decimal point being the number of the article and the figures or figure to the left of the decimal point being the number of the section of which such article is a part. Thus: Article 11.05 indicates Article 5 of Section 11.

SUBDIVISIONS: The parts into which articles are divided. Each subdivision is designated by a number preceding its title, the figure or figures to the right of the article number being the number of the subdivision. Thus: Subdivision 11.05.2 indicates Subdivision 2 of Article 5 of Section 11.

STANDARD SPECIFICATIONS: The document entitled “Standard Specifications for Public Works Construction”, latest edition and supplements thereto, are hereinafter referred to as the Standard Specifications.

Other terms appearing in the Standard Specifications shall have the intent and meaning specified in Section 1 “General” of the Standard Specifications.

In case of conflict between the Standard Specifications and these Special Provisions, these Special Provisions shall take precedence over and be used in lieu of such conflicting portions of the Standard Specifications.

SECTION 2. REQUIREMENTS AND CONDITIONS

ARTICLE 2.01: EXAMINATION OF PLANS, SPECIFICATIONS, SPECIAL PROVISIONS, AND WORKSITE: Bidders must satisfy themselves by personal examination of the proposed work site and by such other means as they may prefer as to the actual conditions and requirements of the work. Bidders shall not at any time after submission of the bid, dispute, complain or assert that there was any misunderstanding in regard to the nature or amount of work to be done.

The CITY, in accordance with Title VI of the Civil Rights Act of 1964 (78 Stat 252) and the Regulations of the Department of Commerce (15 C.F.C., Part 8), issued pursuant to such Act, hereby notifies all bidders that it will affirmatively insure that the contract entered into pursuant to this advertisement will be awarded to the lowest responsible bidder without discrimination of the grounds of race, color or national origin.

ARTICLE 2.02 BID FORMS: All bids submitted shall be made on the blank forms provided with the bid documents. Bids submitted on forms other than those provided with the bid documents shall be rejected. All bids shall give the price bid both in writing and figures and shall be signed by the bidder with his address. Bids shall be enclosed in a sealed envelope directed to the City Clerk, Civic Center, 110 E. La Habra Blvd, La Habra, California 90631.

ARTICLE 2.03 IRREGULAR BIDS: Bids may be rejected if they show any alterations of form, additions not called for, conditional bids, incomplete bids, erasures or irregularities of any kind.

ARTICLE 2.04 DISQUALIFICATION OF BIDDERS: The CITY COUNCIL may reject any and all bids should it deem this for the public good and the bid of any party who has been delinquent or unfaithful in any former contract with the CITY, and may reject all bids other than the lowest bid of any responsible bidder and may award the contract for said work or improvement to the lowest responsible bidder at the prices named in his bid.

ARTICLE 2.05 MATERIAL GUARANTEE: Before any bid is accepted, the bidder may be required to furnish a complete statement of the origin, composition and manufacture of any or all

materials to be used in the construction of the work, together with samples which may be subjected to the tests provided for in these Specifications or in the Special Provisions to determine their quality and fitness for the work.

ARTICLE 2.06 BONDS: In lieu of Section 1-7.2 “Contract Bonds” of the Standard Specifications, the Contractor, simultaneously with the execution of the Agreement, shall furnish a surety bond in an amount equal to one hundred (100) percent of the contract price as security for the faithful performance of the contract and a separate surety bond in an amount equal to one hundred (100) percent of the contract price as security for the payment of all persons performing labor and furnishing materials in connection with the contract. Said bonds shall be secured from a Surety Company satisfactory to the CITY.

ARTICLE 2.07 BID GUARANTEE:

Subdivision 2.07.1: All bids shall be presented under sealed cover and shall be accompanied by cash, cashier’s check, certified check or bidder’s bond made payable to the City of La Habra for an amount equal to at least ten percent (10%) of the amount of said bid. No bid will be considered unless such cash, cashier’s check, certified check or bidder’s bond is enclosed therewith.

Subdivision 2.07.2: Return of Bid Guarantee: The bid guarantee of the bidder or bidders who are being considered for the award of Contract shall be held until the execution of said contract, and shall thereupon be returned to the bidder. Bid guarantee of other bidders will be returned to such bidders upon award of the Contract.

ARTICLE 2.08 AWARD OF CONTRACT: The award of contract, if it be awarded, will be within ninety (90) calendar days of the opening of bids. Prior to City Council award, the lowest apparent bidder shall provide a set of fully executed insurance and a signed agreement.

ARTICLE 2.09 EXECUTION OF CONTRACT: The contract, construction schedule, and bonds shall be executed and filed by the successful bidder with the City Clerk of the City of La Habra not later than ten (10) days after the award of contract.

All bidders may submit with their bids a sworn statement of their financial responsibility, technical ability and experience. Such sworn statement may be required to be furnished before award is made to any particular bidder.

The CITY COUNCIL may, upon the refusal or failure of successful lowest responsible bidder to accept the contract, award it to the second lowest responsible bidder. If the legislative body awards the contract to the second lowest bidder, the amount of the lowest bidder’s security shall be applied by the CITY to the difference between the low bid and the second lowest bid; and the surplus, if any, shall be returned to the lowest bidder if cash or a check is used, or to the surety company if bidder’s bond is used.

ARTICLE 2.10 BEGINNING OF WORK: The Contractor shall begin work from the start date specified in the Notice To Proceed.

ARTICLE 2.11 PLANS AND SPECIFICATIONS: Specifications and bid documents are on file at the Office of the City Engineer, Civic Center, 110 E. La Habra Blvd., La Habra, California. Copies may be purchased from the City Engineer for a fee of twenty five dollars (**\$25.00**) for each set of specifications and accompanying drawings. An additional fee of twenty dollars (**\$20.00**) shall be charged for requests made by mail. No refunds shall be made for sets of said plans, specifications and bid documents returned. A digital copy of said Contract Documents (saved in PDF format) are available free of charge posted at the following website:

<http://www.ciplist.com/>

ARTICLE 2.12 CONTRACT DOCUMENTS: The Contract Documents shall consist of the following: Notice Inviting Bids; Instructions to Bidders; Proposal; Bidder's Information; Bid Schedule; Acknowledgement of Addenda Received; References; DBE Bidder's List; Violations of Federal, State, or Local Laws; Disqualification or Debarment; List of Subcontractors; Bid Security Form; Bid Bond; Non-Collusion Affidavit; Worker's Compensation Certificate; Public Contract Code Section 10285.1 Statement; Public Contract Code Section 10162 Questionnaire; Public Contract Code Section 10232 Statement; Agreement; Labor and Material Payment Bond; Faithful Performance Bond; Supplemental Information to be Completed By Principal; Tax Identification Number; Bid Guarantee; Statement of Non-Collusion By Contractor; Certification of Compliance; Special Provisions; Drawings; and the Standard Specifications for Public Works Construction, latest edition and supplements thereto, together with all additions, deletions, modifications, appendices and all addenda as prepared prior to the date of the bid opening setting forth any modifications or interpretations of any said documents are hereby incorporated in and made a part of the Contract Documents.

All Contract Documents are complementary, and what is called for in any one shall be as binding as if called for in all. The intention of the documents is to require a complete and finished piece of work. The Contractor, at his sole cost and expense, shall perform all labor and services and shall furnish all materials, tools, equipment and facilities necessary for the proper execution of the work, with the exception of such items as may be definitely stipulated in the Specifications or on the Plans to be furnished by the CITY. Anything shown on the Plans and not in the Specifications, or in the Specifications and not in the Plans, shall be performed by the Contractor as though shown on both the Plans and Specifications.

Documents which shall be signed and returned to the CITY with Bid Proposal are:

Proposal; Bidder's Information; Bid Schedule; Acknowledgement of Addenda Received; References; DBE Bidder's List; Violations of Federal, State or Local Laws; Disqualification or Debarment; List of Subcontractors; Bid Security Form; Bid Bond; Non-Collusion Affidavit, Worker's Compensation Certificate; Public Contract Code Section 10285.1 Statement; Public Contract Code Section 10162 Questionnaire; and Public Contract Code Section 10232 Statement.

Documents which are to be signed and returned to the CITY by the winning bidder are:

Agreement; Labor and Material Payment Bond; Faithful Performance Bond;; Supplemental Information to be Completed By Principal; Tax Identification Number; Bid Guarantee; Statement of Non-Collusion By Contractor, Certification of Compliance, Liability Insurance; and Workers Compensation Insurance.

Subdivision 2.12.1 Precedence Of Contract Documents: If there is a conflict between Contract Documents, the order of precedence shall be as follows:

1. Contract
2. Specifications
3. Plans

Within the Specifications, the order of precedence is as follows:

1. Permits from other agencies/Supplemental Agreements
2. Change Orders
3. Addenda
4. Special Provisions
5. Instructions to Bidders
6. Notice Inviting Bids
7. Referenced Standard Drawings
8. Referenced Standard Specifications

With reference to Plans, the order of precedence is as follows:

1. Change Order drawings govern over Addenda and Contract drawings.
2. Addenda drawings govern over contract drawings.
3. Contract drawings govern over shop drawings and Standard drawings.
4. Detail drawings govern over general drawings.
5. Figures govern over scaled dimensions.

ARTICLE 2.13 AUTHORITY OF THE ENGINEER: The Engineer shall have the authority to direct as may be necessary to ensure that the work is in strict compliance with the Contract Documents; determine the quantity, quality and soundness of the work; determine if material and equipment being used is satisfactory; interpret the requirements of the contract; and, make decisions regarding the progress and execution of the work. However, neither the Engineer nor any representative of the Engineer shall have the authority to authorize extra work that is out of scope of the project or increase the cost beyond the contract amount without prior approval by the CITY COUNCIL. Should any discrepancy appear or any misunderstanding arise as to the importance of anything contained in the Specifications or Plans, the matter shall be referred to the Engineer, who shall decide the same in accordance with the true intent and meaning as construed by him. Any difference or conflicts which may arise between the Contractor and any other contractor also under the contract administration of the Engineer shall be arbitrated by the Engineer.

ARTICLE 2.14 ACCESS TO WORK: The Engineer, his agents and duly authorized representatives of the CITY shall at all times and for any purpose, have access to the work and the premises used by the Contractor and the Contractor shall provide safe and proper facilities therefor.

ARTICLE 2.15 LEGAL ADDRESS OF THE CONTRACTOR: The address given in the Proposal is hereby designated as the place to which all notices, letters and other communications to the Contractor shall be mailed or delivered. The mailing or delivering to the above-named place of any notice, letter or other communication to the Contractor, shall be deemed sufficient service thereof upon the Contractor. The date of said service shall be the date of such mailing or delivery. Such address may be changed at any time by a written notice signed by the Contractor and delivered to the Engineer.

ARTICLE 2.16 CONTRACTOR'S RESPONSIBILITIES: The Contractor shall be responsible for the safe, efficient and adequate use of equipment during the progress of the work so as to secure the safety of the workers and others. The Contractor is also responsible for the quality of work required and the stipulated rate of progress. It shall be the Contractor's responsibility to perform the work strictly in accordance with the Specifications and Plans or in accordance with modifications as may be made by the Engineer in the form of addendum or written change orders. The presence of the Public Works Inspector does not relieve the Contractor of his obligation to comply with the requirements of the Plans, Specifications and Contract Documents.

The Contractor shall assume the defense of and indemnify and save harmless the CITY and its officers and agents from all claims of any kind arising from his own negligence or that of his agents in the performance of the Contract.

The Contractor shall be responsible for the custody of any material furnished him for the care of all work until its completion and final acceptance. He shall, at his own expense, replace damaged or lost material and repair damaged parts of the work, regardless of cause, or the same may be done at the Contractor's expense by the CITY.

During the progress of the work the Contractor shall keep the worksite in a neat and clean condition and free from any unsightly accumulation of rubbish. If stockpiling is necessary, the material shall be removed or disposed of weekly. He shall remove from the vicinity of the completed work all plant, building, rubbish, unused materials, concrete forms and equipment belonging to him or used under his direction during construction. In the event of his failure to do so, the same may be removed by the CITY at the Contractor's expense.

All operations of the Contractor shall be conducted in such a manner as to avoid unnecessary dust. To this end, the Contractor shall provide equipment, materials, water, and labor to keep all parts of the work adequately sprinkled and dust free as determined by the Engineer. Full compensation for dust control measures and conforming with the provisions of this Section shall be included in the prices paid for the various contract items of work listed in the Bid Schedule, and no additional compensation will be allowed therefor.

SECTION 3. SCOPE OF WORK

ARTICLE 3.01 WORK TO BE DONE: The Contractor shall for the price bid furnish all the necessary labor, materials, equipment, methods, processes, implements, tools, and machinery except as otherwise specified to perform the required work in a thorough and workmanlike manner in accordance with the plans and specifications, and to the satisfaction of the Engineer.

The general items of work to be performed hereunder consist of but not be limited to

Mobilization/Demobilization; Traffic Control, Safety and Cleanup; Construction Staking and Monument Perpetuation; Storm Water Best Management Practices (BMPs); Adjust to Grade Manhole Covers, Water Valves; Unclassified Excavation and Disposal; Sawcut and Remove Existing and Construct Curb Ramp with Detectable Warning Surface; Sawcut and Remove Existing and Construct Concrete Curb and Gutter and Cross Gutter over CMB with AC Slot Trench; Construct AC Base Paving, Coldmill and Dispose of Existing Asphalt; Construct Rubberized AC pavement Overlay, Crack Seal and Slurry Seal Type II with 2.5% Latex Rubber; Traffic Striping, Crosswalks, Curb Painting, Markings, and Raised Pavement Markers; Traffic Signal Loop Detectors; and all incidental work so indicated on the specifications, and required for the proposed improvements.

ARTICLE 3.02 FINAL CLEANING UP: Before acceptance of the work and final payment therefor, the Contractor shall clean the work and all ground occupied by him in connection with the work, of all rubbish, excess materials, equipment and forms. All parts of the work shall be left in a neat and presentable condition.

ARTICLE 3.03 REPAIRS AND REPLACEMENTS: All damage done to existing facilities and improvements by the Contractor shall be repaired by him to the satisfaction of the Engineer. Where sidewalks, curbs or gutters are to be repaired, the repairs shall be made by removing and replacing the entire section back to the nearest scoring lines and not by refinishing the damaged portion.

SECTION 4. CONTROL OF THE WORK

ARTICLE 4.01 COORDINATION OF PLANS, SPECIFICATIONS AND SPECIAL PROVISIONS: These specifications, drawings, special provisions and all supplementary documents are essential parts of the contract. A requirement occurring in one is as binding as though occurring in all. The drawings and specifications are intended to be cooperative and to describe and provide for the workmanlike completion of proposed improvements. Refer to Subdivision 2.12.1 for precedence of Contract Documents.

ARTICLE 4.02 SPECIFICATIONS AND DRAWINGS: The Contractor shall keep at the work site a copy of the Specifications and Plans at all times and provide the Engineer access thereto.

The Contractor shall check all dimensions and quantities on the drawings or schedules herein contained or given to him by the Engineer, and shall notify the Engineer of errors therein which

may be discovered by examining and checking the drawing. He shall not take advantage of any error or omission in these specifications, drawings or schedules, but should such error or omission be discovered, the Contractor shall notify the Engineer and the Contractor shall carry out the Engineer's instructions, as if originally specified.

ARTICLE 4.03 SUPERVISION BY THE CONTRACTOR: The Contractor shall give his personal superintendence to the work, using all his skills and attention in directing the performance of the work or he shall provide a competent, full-time superintendent or foreman with the authority to act on his behalf and whom shall be present to direct the work on the project at all times during its progress. All directions given to the Contractor's superintendent or other authorized supervisory employee shall be as binding as if delivered to the Contractor personally.

ARTICLE 4.04 LABOR: Any overseer, superintendent, laborer or other person employed by the Contractor who shall perform his work in a manner contrary to the specifications shall be discharged immediately and such person shall not again be employed on the project.

ARTICLE 4.05 LINES AND GRADES: The Contractor will set all lines and grades in accordance with the plans and all work done shall conform thereto. The Contractor shall dig all stake holes necessary to give lines and grades. The Contractor shall preserve all stakes set for lines, grades or measurements of the work in their proper places until authorized to remove them by the Engineer. Any expense incurred in replacing stakes which the Contractor or his subordinates may have failed to preserve shall be borne by the Contractor. Unless otherwise noted, the grade between two grade points shall be a straight line between such two points.

ARTICLE 4.06 INSPECTION: The Contractor shall notify the Engineer at least 48 hours in advance of starting or resuming work so that the Engineer can arrange for an assistant engineer or inspector to be present. Failure to give such notice shall be cause for rejection of such work. The Contractor shall furnish the engineers and inspectors reasonable facilities for obtaining such information as may be necessary to give them full information at all times respecting the progress and manner of doing the work and the character of the materials.

Subdivision 4.06.1 Special Inspection Fees: If the Contractor elects to work under this contract more than 8 hours per day and 40 hours per week; or Saturday, Sunday, overtime, or CITY Holidays, the Contractor shall arrange with the Engineer for the required inspection service and pay the special inspections fees which will be charged at the following rates:

| | |
|---|-----------------|
| Monday through Friday | \$150.00 / hour |
| Saturday, Sunday, overtime and Holidays | \$200.00 / hour |

ARTICLE 4.07 DEFECTIVE WORK OR MATERIALS: Inspection of the work shall not relieve the Contractor of his obligation to fulfill his duty as herein prescribed. Defective work shall be made good by the Contractor. Unsuitable work and materials may be rejected

notwithstanding that such work and materials were previously inspected by the Engineer and accepted or estimated for payment. If the work, or any part thereof, is determined to be defective at any time before final acceptance of the work, the Contractor shall forthwith make good such defect without additional compensation in a manner satisfactory to the Engineer.

If materials furnished and brought upon the job site by the Contractor for use in the work, or selected for the same by him shall be condemned by the Engineer as unsuitable or not in conformity with the Specifications, the Contractor shall forthwith discard such materials and remove them to a satisfactory distance from the vicinity of the work.

If the Contractor fails or neglects to make ordered repairs to defective work, or to remove rejected materials from the work site within 10 days after notification by the Engineer, the Engineer acting on behalf of the CITY may make the ordered repairs or remove the condemned materials and deduct the cost thereof from monies due to the Contractor.

ARTICLE 4.08 EQUIPMENT AND PLANT: Equipment not suitable to produce the quality of work required will not be permitted to operate on the project.

Plants, tools and equipment shall be designed and constructed in accordance with general practice for such equipment and shall be of sufficient capacity and of such character to insure the production of sufficient material to take the work to completion within the scheduled time frame. The Contractor shall provide adequate and suitable equipment and plants to meet the above requirements and when ordered by the Engineer shall remove unsuitable equipment from the worksite and discontinue receiving materials from unsatisfactory plants.

ARTICLE 4.09 ADDITIONS OR OMISSIONS OF WORK, LABOR OR MATERIALS:

Subdivision 4.09.1: Additions: The Contractor shall make additional excavations, furnish and place additional imported borrow, plant-mixed surfacing, concrete or do other additional work or furnish other additional materials where the necessity for or the extent of such work or materials does not appear and cannot with reasonable diligence, cost and certainty, be determined in advance or will only be disclosed by the doing of the work or in any contingency which reasonable care and consideration could not be foreseen. Such additional work or materials shall be specified in writing by the Engineer, subject to approval of the CITY COUNCIL, and shall be paid for at the unit prices set for in the contract.

Subdivision 4.09.2: Omissions: The Contractor shall omit any portion of the work, labor or materials required to be done or furnished under the plans and the specifications when the necessity for the omission of said work, labor or materials does not appear and cannot with reasonable certainty, diligence and cost be ascertained in advance or will only be disclosed by the doing of the work or in any contingency which reasonable care and consideration could be foreseen; which said omission of work, labor or materials shall be specified and required in writing by the Engineer, subject to the approval of the CITY COUNCIL, and shall be deducted from the contract price at the unit prices therefore set forth in said contract. Where the contract price is a

lump sum, then the cost of the amount deducted shall be proportion of said lump sum such as the quantity of work, labor or materials omitted bears to the quantity upon which said lump sum is based.

Subdivision 4.09.3: Mark-Ups For Extra Work: The Contractor shall use the specified mark ups for all approved extra work:

For General Contractor's work, 15% mark-up for materials and equipment; and 20% mark-up for labor.

For Subcontracted work, 10% mark-up for the first \$5,000; and 5% mark-up for costs in excess of \$5,000.

No mark-up for bonds shall be allowed.

Subdivision 4.09.4: Tool and Equipment Rental: The rates to be used in determining equipment rental costs shall be as listed in the Caltrans "Labor Surcharge and Equipment Rental Rates" publication in effect at the time of bid.

ARTICLE 4.10 FINAL INSPECTION: The Engineer will not make the final inspection until the work provided and contemplated by the contract has been completed and the final clean-up performed.

ARTICLE 4.11 CONTRACTOR REPORTING REQUIREMENTS: The following items shall be required as a part of Contractor payment requests. Incomplete submittal or omission of any of the following requirements shall be cause for rejection and return of payment requests to the Contractor for correction. All items shall be complete and current to the satisfaction of the Engineer. The Contractor shall provide all information for his own firm as well as each and every subcontractor. Payment requests shall include at least the following items:

- Breakdown of each pay item showing locations and quantities of work requested for payment.
- Certification that the as-built records are current and documented in writing.
- Submission of DBE information including DBE amounts completed to date, DBE providers, Monthly DBE Trucking Utilization Report, and certification that the Contractor is meeting DBE contractual requirements.
- Certified Payroll Reports.
- Updated work schedule.
- All change order requests complete to date, including all Force Account cost supporting documentation.
- Copies of all SWPPP and other Best Management Practices reports, and certification that BMP's are current and implemented.
- Copies of test results (if testing is required of Contractor).
- Survey records, maps, cut sheets, calculations, and other data.
- Subcontractor Change Requests and subcontractor data.
- Other forms or reports as may be required by contract.

ARTICLE 4.12 PENALTIES: Notwithstanding penalty provisions elsewhere in these specifications, the CITY may impose financial penalties in the case of the Contractor not fulfilling his contractual obligations. These obligations include, but are not limited to, performing work within the time limits of the contract; public notification; implementation of Best Management Practices, SWPPP, and other management plans; maintaining records; notification of the Engineer; traffic control; safety; controlling the work area; maintaining a competent supervisor on site at all times while performing work; surveying; testing; updating of schedules; and other such contractual obligations. The Contractor shall be responsible for all obligations and penalties applied to subcontractors as if he himself were performing the work.

The amount of penalty shall be equal to the daily liquidated damages, prorated for each 15 minute period, or portion of 15 minutes, of contract violation. Each violation shall be additive if multiple violations occur during the same time period.

ARTICLE 4.13 CLEANUP, TRAFFIC CONTROL, SAFETY: The Contractor shall maintain complete liability and responsibility for implementing project site cleanliness, traffic control, and safety at all times. If, in the opinion of the Engineer or his designated representative, there is a condition warranting corrective action by the Contractor, the Contractor will be advised and requested to correct the condition to the satisfaction of the Engineer. This requirement in no way absolves the Contractor of any obligation or duty to provide for the safety of persons and property at all times, nor does it impose any obligation or duty on the Engineer to provide any such services or advisement.

The Contractor's supervisor will not leave the project site until he has personally inspected and verified that all cleanliness, traffic control, and safety conditions are in a suitable condition, and has informed the Engineer that he has performed such an inspection. Likewise, no work may commence at the beginning of the work day until all cleanliness, traffic control, and safety measures and procedures have been reviewed, discussed, and implemented by the supervisor with all of the Contractor's and subcontractor's forces.

In the event that the Contractor does not immediately respond to the Engineer's request for corrective action, and the situation presents a hazard to persons and/or property, the Engineer may cause the work to be corrected by others. Likewise, in the event that the Contractor is not on site, cannot immediately respond, or is otherwise unavailable, the Engineer may cause the work to be corrected by others. If corrective work is performed by others, then the Contractor may be charged for all of the costs, including overhead and indirect costs, required to correct the work. Inspector's costs shall be per Article 4.06 INSPECTION. Engineer's costs shall be 1.5 times the noted Inspector's rate. In addition, the Engineer may impose additional penalties as provided for elsewhere in these specifications.

Full compensation for conforming to the requirements in this article shall be considered as included in the prices bid for the various contract items of work involved and no additional compensation will be allowed therefor.

ARTICLE 4.14 REMOVAL OF PERSONNEL: The Engineer reserves the right to direct the Contractor to remove any specified personnel from the project at any time without reason. If directed, the Contractor shall immediately remove such personnel from the project site, and replace such with another competent person. This requirement shall apply to subcontractor personnel as if they were the Contractor's personnel. Violation shall be subject to penalties as noted elsewhere in these specifications.

SECTION 5. CONTROL OF MATERIAL

ARTICLE 5.01 DRAWINGS AND INFORMATION REQUIRED OF CONTRACTOR: The Contractor shall before proceeding with the fabrication or erection of structures or appurtenances if called for under the contract and required in its erection thereof, furnish the Engineer with the information regarding same and shall submit to the Engineer for approval drawings, specifications, lists and graphs as required under these specifications. Said drawings, specifications, lists and graphs shall become the property of the CITY. In the event that the Engineer shall find that the drawings, specifications, lists and graphs as submitted by the Contractor, are in accordance with acceptable practice and meet the requirements of these specifications, the Engineer will return one (1) set of drawings and lists with his approval within 10 days after their receipt at the Engineer's office; otherwise, said drawings will be returned to the Contractor within the said 10 day period with a statement of the points wherein they have been found unsatisfactory, in which case, the Contractor at his own expense, shall proceed at once to revise said drawings and lists until they shall be found satisfactory by the Engineer and are approved by him. No fabrication shall be done prior to approval of drawings and lists. The Contractor shall have no claim for damages or extension of time on account of any delay due to revision of drawings as found necessary by the Engineer in order to fulfill the requirements of these specifications; but, regardless of such delays, the Contractor shall be liable to the CITY as provided in the specifications for any failure to complete the work as required by the terms of the contract. Revisions shown on shop drawings shall be considered as changes necessary to meet the requirements of specifications and shall not be taken as the basis of claims for extra work.

The approval of all drawings by the Engineer shall apply to general design only and shall in no way relieve the Contractor from responsibility for errors or omissions contained therein; nor shall said approval operate to waive or modify any provisions or requirement contained in these specifications.

ARTICLE 5.02 SAMPLES AND TESTS: All tests of materials furnished by the Contractor shall be made by a laboratory authorized by the Engineer to make the tests and work involved in the contract. The expense of such tests shall be included in the prices bid for the work.

Tests shall be made in accordance with commonly recognized standards of national organizations and such special methods and tests as are described in the Standard Specifications.

No material shall be used until it has been approved by the Engineer. Samples will be secured and tested whenever necessary to determine the quality of materials.

Whenever reference is made in these specifications to standard tests or requirements of the American Society for Testing Materials, the reference shall be construed to mean the standards that are in effect at the date of these specifications.

ARTICLE 5.03 STORAGE OF MATERIALS: Materials shall be so stored as to insure the preservation of their quality and fitness for the work. When considered necessary by the Engineer, they shall be placed on wooden platforms or other hard, clean surfaces and not on the ground. They shall be placed under cover when so directed. Stored materials shall be so located as to facilitate prompt inspection.

ARTICLE 5.04 SUBSTITUTION OF EQUIVALENTS: On the demand of the City, the Bidder shall, at his own expense, furnish information or data concerning the article, equipment, material, or process offered by him as an equivalent to that specified; and, if the CITY shall so require, the Bidder, at his own expense, shall have the article, equipment, materials or process tested to its quality, strength, physical, chemical or other characteristics, its durability, finish, efficiency or service by a reputable testing engineer or laboratory satisfactory to the CITY.

In accordance with California Public Contract Code §3400(a), and as specified herein this Section, the Contractor shall submit its list of proposed substitutions for “an equal” (“or equal”) item within 20 days after award of the contract. If an offered substitution by the Contractor for the trade names specified in the plans and specs necessitates changes to, or coordination with, other items of the Work, the information submitted shall include details showing such changes. The Contractor shall perform these changes as part of the substitution of material or equipment and at no additional cost to the CITY. The lack of action on the Engineer’s side by taking no exceptions to the proposed substitution shall not relieve the Contractor from responsibility for the efficiency, sufficiency, quality, and performance of the substitute material or equipment, in the same manner and degree as the material and equipment specified by name.

Whenever materials or equipment are indicated in the Contract Documents by using the name of a proprietary item or the name of a particular Supplier, the naming of the item is intended to establish the type, function, and quality required. Unless stated otherwise, materials or equipment of other Suppliers may be accepted if sufficient information is submitted to the Engineer for review to determine whether the material or equipment proposed is equivalent or equal to that named.

Request for approvals of “or equal” items prior to Bid Opening will not be considered. Bidders are responsible to ensure their Bid includes the price required for the item as specified, and assumes all risk in including a price for an “or equal” item that is not approved by the Engineer, and any additional cost associated with furnishing and installing the item as specified in the specifications or plans.

The Contractor may bring forward a substitution proposal for an “or equal” item provided the request and supporting documentation is submitted within 20 days of contract award. The following information shall be included with any substitution request:

Whether or not acceptance of the substitute for use in the Work will require a change in any of the Contract Documents to adopt the design to the proposed substitute.

Whether or not incorporation or use of the substitute in connection with the Work is subject to payment of any license fee or royalty.

All variations of the proposed substitute from the items originally specified will be identified.

Certification that the proposed substitute will perform adequately the functions and achieve the results called for by the general design, and be similar and of equal substance to that indicated, and be suited to the same use as that specified.

There is no guaranteed time frame for the Engineer's review of the substitution requests.

The Contractor is responsible to demonstrate that the type, function, and quality of any such substitute product, material or equipment is equivalent to the specified item. The Engineer shall require at the Contractor's expense additional data about the proposed substitution he deems necessary.

If the Engineer takes no exceptions to the proposed substitution, it will not relieve the Contractor from responsibility for the efficiency, sufficiency, quality, and performance of the substitute material or equipment, in the same manner and degree as the material and equipment specified by name.

The lack of any action by the Engineer does not constitute acceptance of the substitution; all approved "or equal" substitutions must be approved in writing by the Engineer.

Acceptance by the Engineer of a substitute item does not relieve the Contractor of the responsibility for full compliance with the Contract Documents.

The Bid submittal must be based on the material and equipment specified by name per the Special Provisions and/or the Project plans. If the proposal is rejected by the Engineer, you will not be entitled to either an extension in Contract Time, and/or an increase in the Contract Price.

As applicable, no Shop Drawing or Working Drawing submittals will be made for a substitute item nor will any substitute item be ordered, installed, or utilized without the Engineer's prior written approval.

Whether approved or disapproved, the Contractor must reimburse the CITY for the charges of the Engineer for evaluating each proposed substitution.

SECTION 6. LEGAL RELATIONS AND RESPONSIBILITIES

ARTICLE 6.01 LAWS TO BE OBSERVED AND DISPUTE RESOLUTION:

Subdivision 6.01.1 Laws and Regulations: The Contractor shall keep himself fully informed of all Federal and State laws, County and CITY ordinances and regulations which, in any manner, affect those engaged or employed on the work, the materials used in the work or the

conduct of the work. If any discrepancy or inconsistency should be discovered in this contract or in the Plans or Specifications herein referred to, in relation to any such law, ordinance or regulation, the Contractor shall forthwith report the same in writing to the Engineer. The Contractor shall, at all times, observe and comply with and shall cause all his agents and employees to observe and comply with all such applicable laws, ordinances and regulations in effect or which may become effective before completion of this contract. He shall protect and indemnify the CITY and its officers and agents against any claim or liability arising from or based on the violations of any such laws, ordinances or regulations whether by himself or by his employees or his subcontractors or their employees.

Except as otherwise explicitly provided in these specifications, all permits and licenses necessary to the prosecution of the work shall be secured by the Contractor at his own expense and he shall pay all taxes properly assessed against his equipment or property used or required in connection with the work.

All state laws, all county and CITY ordinances and regulations now imposed by competent authority and relating to any materials required to be furnished under these specifications and work required to be done hereunder, shall be deemed to be and hereby are made controlling and part of these specifications.

Subdivision 6.01.2 General: The Contractor shall keep himself fully informed of all existing state and national laws and municipal ordinances and regulations which in any manner affect those engaged or employed in the work, or the materials used in the work or which in any way affect the conduct of the work and of all such orders and decrees of bodies or tribunals having any jurisdiction or authority over the same.

Subdivision 6.01.3 Eight-Hour Law: Eight (8) hours labor constitutes a legal day's work. The Contractor shall forfeit as a penalty twenty-five dollars (\$25.00) for each workman employed in the execution of the contract by the Contractor or any subcontractor under him for each calendar day during which such workman is required or permitted to work more than eight (8) hours in any one calendar day and forty (40) hours in any one calendar week in violation of the provisions of the Labor Code and in particular, Section 1810 to Section 1815 thereof inclusive except that work performed by employees of Contractors in excess of eight (8) hours per day and forty (40) hours during any one week, shall be compensated at not less than one and one-half (1 ½) times the basic rate of pay as provided in Section 1815.

Subdivision 6.01.4 Prevailing Rate of Per Diem Wages: Pursuant to the provisions of Section 1773 of the Labor Code of the State of California, the Director of Industrial Relations has ascertained the general prevailing rate of wages and employer payments for health and welfare, vacation, pension and similar purposes applicable to the work to be done.

The Contractor shall comply with Labor Code Section 1775. In accordance with said section, the Contractor shall forfeit as a penalty to the CITY fifty dollars (\$50.00) for each calendar day, or portion thereof, for each workman paid less than the stipulated prevailing rates for such work or craft in which such workman is employed for any work done under the contract by him or by any subcontractor under him in violation of the provisions of the Labor Code and in particular Labor

Code Sections 1770 to 1780, inclusive. In addition to said penalty and pursuant to said Section 1775, the difference between such stipulated prevailing wage rates and the amount paid to each workman for each calendar day or portion thereof for which each workman was paid less than the stipulated prevailing wage rate shall be paid to each workman by the Contractor.

Subdivision 6.01.5 Certified Payroll: Pursuant to Section 1776 of the Labor Code, the Contractor and/or subcontractors shall submit weekly to the CITY for each week in which any contract work is performed a certified copy of all payroll records. Should the Contractor fail to provide such payroll certificates, the CITY may withhold one thousand dollars (\$1,000) for each weekly payroll certificate not received from payment due.

Subdivision 6.01.6 Governing Law, Venue, Dispute Resolution and Attorneys' Fees: This Agreement will be governed by and construed in accordance with laws of the State of California. Specifically, Government Code Section 9204 (A summary of which is set forth in Subdivision 6.01.7). If any disputed portion of the claim is not resolved with the procedure set forth in Subdivision 6.01.7 herein, prior to commencing suit in a court of competent jurisdiction, any unresolved portion of any controversy, dispute or claim arising out of the Agreement will first be submitted to an alternative dispute resolution process as set forth in Subdivision 6.01.8 herein. Any action at law or in equity brought by either of the parties hereto for the purpose of enforcing a right or rights provided for by this Agreement will be tried in a court of competent jurisdiction in the County of Orange, State of California. In the event either party hereto will bring suit to enforce any term of this Agreement or to recover any damages for and on account of the breach of any term or condition of this Agreement, it is mutually agreed that the prevailing party in such action will recover all costs thereof, including reasonable attorneys' fees, to be set by the court in such action.

Subdivision 6.01.7 Summary of Government Code Section 9204: A "claim" is a separate demand on the CITY by a Contractor on a public works project and sent by registered mail or certified mail with return receipt requested, for one or more of the following:

- A time extension, including relief from penalties for delay;
- Payment by the CITY of money damages under the terms of the contract;
- Payment of an amount that is disputed by the CITY.

Initial Review. The claim must be supported by appropriate documentation. The CITY has forty-five (45) days within which to review the claim and provide the Contractor with a written statement identifying the disputed and undisputed portions of the claim. If the CITY does not issue a written statement, the claim is deemed rejected in its entirety. The CITY will pay any undisputed portion of the claim within sixty (60) days of issuing the statement.

Meet & Confer. If the Contractor disputes the CITY's written response, or if the CITY does not issue one, the Contractor may request in writing an informal conference to meet and confer for possible settlement of the claim. The CITY will schedule the meet and confer conference within thirty (30) days of this request and provide a written statement identifying the remaining disputed and undisputed portions of the claim within ten (10) business days of the meet and confer. The CITY will pay the undisputed portion within sixty (60) days of issuing this statement.

Mediation. With respect to any disputed portion remaining after the meet and confer, the CITY and Contractor must submit the matter to nonbinding mediation, agree to a mediator within ten (10) business days after issuing the written statement, and share mediation costs equally. If mediation is unsuccessful, then the terms of the public works agreement and applicable law will govern resolution of the dispute.

Miscellaneous Provisions. Amounts not paid by the CITY in a timely manner bear interest at 7% per annum. Subcontractors may submit claims via this procedure through the general contractor. The CITY and Contractor may waive the requirement to mediate, but cannot otherwise waive these claim procedures.

Subdivision 6.01.8 Alternative Dispute Resolution: In the event that there is any controversy, dispute or claim arising out of or relating to this Agreement, which have not been resolved pursuant to the process summarized in Subdivision 6.01.7 herein, the parties hereto will consult and negotiate with each other and, recognizing their mutual interest, attempt to reach a solution satisfactory to both parties. If they do not reach settlement within a period of sixty (60) days, the matter will be submitted to nonbinding arbitration (“Process”) by written notice from either party to the other. The parties will meet and confer in good faith and select an arbitrator that is agreeable to both sides. The Process will be completed no later than one hundred twenty (120) days (“Process Period”) after tender of the aforementioned written notice, unless the Parties mutually agree to an extension of the Process Period. If the matter is not successfully resolved by the Process, within the Process Period, the parties are free to commence litigation in a court of competent jurisdiction as defined in Subdivision 6.01.6 herein. Any litigation commenced without both parties’ consent prior to the end of the Process Period, will be subject to a stay until the end of the Process Period. The Parties further agree to equally bear the cost of the Process.

ARTICLE 6.02 PERMITS AND LICENSES: The Contractor shall procure all permits and licenses, pay all charges and fees, and give all notice necessary and incident to the due and lawful prosecution of the work. No fee is charged for an Encroachment Permit issued by the CITY for a Public Works Project. The Contractor and his subcontractors shall obtain a CITY Business License. Contract shall obtain Union Pacific Railroad Permit.

Full compensation for conforming to the requirements in this article shall be considered as included in the price bid for the various contract items of work involved and no additional compensation will be allowed therefor.

ARTICLE 6.03 PATENTS: The Contractor shall assume all costs arising from use of patented materials, equipment, devices or processes used on or incorporated in the work and agrees to indemnify and save harmless the CITY, the CITY COUNCIL, the City Engineer and their fully authorized representatives from all suits of law or actions of every nature for, or on account of, the use of any patented materials, equipment, devices or processes.

ARTICLE 6.04 PRESERVATION OF PROPERTY: The Contractor shall conduct the operations in a careful and prudent manner to avoid damage to adjacent property.

The Contractor shall preserve and protect all on-site and roadside trees from injury. All trees useful for shade or other purposes shall be cared for by the Contractor and no trees within the limits of project site shall be cut or removed unless indicated on the plans.

All fences along the line of the improvement shall be protected by the Contractor; if they are injured or destroyed they shall be restored to a condition as good as when he entered upon the work. It is required that the Contractor replace in kind or reimburse the owners thereof for all fences, shrubs, buildings and other improvements damaged or removed by the construction operations not shown on the plans.

The Contractor shall preserve and protect from damage to all buildings, pole lines, pipe lines and all direction, warning and mileage signs and any other structures which have been placed within the limits of the project site.

Full compensation for conforming to the requirements in this article shall be considered as included in the price bid for the various contract items of work involved and no additional compensation will be allowed therefor.

ARTICLE 6.05 PRESERVATION OF MONUMENTS: The Contractor shall not disturb any monuments, stakes or sign posts found on the line of the improvement until authorized by the Engineer. The Contractor shall bear the expense of resetting any monument, stakes or sign posts which may be disturbed without authorization from the Engineer. After construction and prior to final acceptance, the Contractor's land surveyor or qualified Civil Engineer shall re-survey all field monuments and centerline ties within the construction zone, prepare tie sheets and Corner Record sheets, and file them with the City Engineer for review. After review by the City Engineer, the land surveyor shall file the Corner Records with the Orange County Land Surveyors Office as required by law, and file certified copies of the Corner Records with the City Engineer. Project retention will not be released until all records are recorded with the County Land Surveyor Office.

ARTICLE 6.06 RESPONSIBILITY FOR DAMAGE: During the progress of the work, the CITY will not be answerable or accountable, in any manner, for any loss or damage that may happen to the work or any part thereof; or for injury to any person or persons, either workmen or the public, or for damage to adjoining property from any cause which might have been prevented by the Contractor or his workmen or any one employed by him, against all of which injuries or damages to persons and property the Contractor having control over such work must properly guard. The Contractor shall be responsible for any damage to any person or property resulting from defects or obstructions or from any causes whatsoever during the progress of the work, or at any time before its completion and final acceptance and shall indemnify and save harmless the CITY and/or its officers and/or its employees from all suits or actions of every name and description brought for or on account of any injuries or damages received or sustained by any person or persons by or from the Contractor, his servants or agents in the construction of the work or by or in consequence of any negligence in guarding the same in improper materials used in its construction or by or on account of any act or omission of the Contractor or his agents.

ARTICLE 6.07 COOPERATION BETWEEN CONTRACTORS: Where two or more contractors are employed on related or adjacent work, each shall conduct his operations in such a manner as

not to cause any unnecessary delay or hindrance to the other. Each contractor shall be responsible to the other for all damage to work, person or property or for loss caused by failure to finish the work within the time specified for completion.

ARTICLE 6.08 CONTRACTOR'S RESPONSIBILITY FOR WORK: Except as provided above, until the formal acceptance of the work by the CITY COUNCIL, the Contractor shall have the charge and care thereof and shall bear the risk of injury or damage to any part thereof by the action of the elements or from any other cause whether arising from the execution or from the non-execution of the work. The Contractor shall rebuild, repair, restore and make good all injuries or damages to any portion of the work occasioned by any of the above causes before its completion and acceptance and shall bear the expense thereof except for such injuries or damages as occasioned by acts of the Federal Government and the public enemy. In case of suspension of work from any cause whatever, the Contractor shall be responsible for all materials and shall properly store them, if necessary, and shall provide suitable drainage of the project site and erect temporary structures where necessary.

ARTICLE 6.09 NO PERSONAL LIABILITY: Before the contract is executed on behalf of the CITY, a bidder to whom the contract has been awarded shall furnish to the CITY a policy or certificate of protective liability insurance in which the CITY shall be named as an additional insured with the bidder. The policy shall insure the CITY, his officers, and his employees; the bidder, his employees and his subcontractors and their employees, their heirs, agents and employees; while acting within the scope of their duties against all claims arising out of or in connection with the work to be performed and shall remain in full force and effect until the work is accepted by the CITY. The policy shall provide for the following limits:

Minimum Scope of Insurance.

- A. Workers Compensation & Employers Liability Insurance
 - Workers Compensation insurance with statutory limits as required by the Labor Code of the State of California.
 - Employers Liability with limits of \$1,000,000 per Accident; \$1,000,000 Disease per employee; \$1,000,000 Disease per policy.
 - The policy shall include a written waiver of the insurer's right to subrogate against CITY.
 - Required Evidence Of Coverage:
 - 1. Subrogation waiver endorsement; and
 - 2. Properly completed Certificate of Insurance.

- B. General Liability Insurance
 - Commercial General Liability Insurance no less broad than Insurance Services Office (ISO) form CG 00 01.
 - Coverage shall be on a standard occurrence form. Claims-Made forms are not acceptable without prior written consent. Modified, limited or restricted Occurrence forms are not acceptable without prior written consent.
 - Minimum Limits: \$2,000,000 per Occurrence; \$4,000,000 General Aggregate; \$4,000,000 Products/Completed Operations Aggregate. The General Aggregate

shall apply separately to each project. The required limits may be provided by a combination of General Liability Insurance and Commercial Excess or Umbrella Liability Insurance. If contractor maintains higher limits than the specified minimum limits, CITY requires and shall be entitled to coverage for the higher limits maintained by contractor.

- Any deductible or self-insured retention shall be shown on the Certificate of Insurance. If the deductible or self-insured retention exceeds \$25,000 it must be approved in advance by CITY. Contractor is responsible for any deductible or self-insured retention and shall fund it upon CITY'S written request, regardless of whether Contractor has a claim against the insurance or is named as a party in any action involving CITY.
- Coverage shall be continued for one (1) year after completion of the work.
- CITY shall be endorsed as an additional insured for liability arising out of ongoing and completed operations by or on behalf of the contractor. CITY shall continue to be an additional insured for completed operations for (1) year after completion of the work.
- The policy definition of "insured contract" shall include assumptions of liability arising out of both ongoing operations and the products-completed operations hazard ("f" definition of insured contract in ISO form CG 00 01, or equivalent).
- The insurance provided to the additional insureds shall be primary to, and non-contributory with, any insurance or self-insurance program maintained by them.
- The policy shall cover inter-insured suits and include a "Separation of Insureds" or "severability" clause which treats each insured separately.
- The policy shall be endorsed to include a written waiver of the insurer's right to subrogate against all persons or entities that are, or are required to be, additional insureds.
- The policy shall not contain a Contractors' Warranty or other similar language which eliminates or restricts insurance because of a subcontractor's failure to carry specific insurance or to supply evidence of such insurance.
- Required Evidence of Coverage:
 1. Copy of the additional insured endorsement or policy language granting additional insured status;
 2. Copy of the endorsement or policy language indicating that coverage applicable to the additional insureds is primary and non-contributory;
 3. Properly completed Certificate of Insurance; and
 4. Completed and signed Agent/Broker Questionnaire with supporting documentation as required.

C. Automobile Liability Insurance

- Minimum Limit: \$2,000,000 combined single limit per accident.
- Coverage shall apply to all owned, hired and non-owned vehicles.
- CITY shall qualify as an insured.
- Required Evidence of Coverage:
 1. Copy of the endorsement or policy language indicating that CITY is an insured; and
 2. Properly completed Certificate of Insurance.

D. Standards for Insurance Companies

- Insurers, other than the California State Compensation Insurance Fund, shall have an A.M. Best's rating of at least A:VII.

All insurance issued in compliance with this section shall be insured in the form and by the insurer or insurers satisfactory to and first approved by the CITY in writing. The Contractor shall not allow any subcontractor to commence work on his subcontract until the subcontractor has secured all required bonds and insurance.

ARTICLE 6.10 WORKER'S COMPENSATION INSURANCE: The Contractor shall procure and maintain Worker's Compensation Insurance as required by applicable state or territorial law for all of his employees to be engaged in work at the site of the project under this Contract. In case of any such work sublet, the Contractor shall require the subcontractor similarly to provide Worker's Compensation Insurance for all of the latter's employees to be engaged in such work unless such employees are covered by the protection afforded by the Contractor's Worker's Compensation Insurance. In case any class of employees engaged in hazardous work on the project under this Contract is not protected under the Worker's Compensation Statute, the Contractor shall provide and shall cause each subcontractor to provide adequate employer's liability insurance for the protection of such of his employees as are not otherwise protected.

The Contractor and/or subcontractor shall file a copy of their Certificate of Compensation Insurance with the CITY and no work shall begin until such certificate is filed with the CITY. In the event of cancellation, the insurance company shall give the CITY ten (10) days written notice.

ARTICLE 6.11 SUBCONTRACTING: Attention is directed to the provisions in Section 1-6.2, "Subcontractor Listing", of the Standard Specifications and these Special Provisions.

In accordance with the requirements of Sections 4100 to 4133 inclusive of the Public Contract Code, each bidder shall list in his Proposal the name and business address of each subcontractor to whom the bidder proposes to subcontract all or a portion of work and shall list each subcontractor licensed by the State of California proposed by the bidder to specially fabricate and install all or a portion of the work. Said list shall include a description of the portion of the work which will be done by each subcontractor.

A sheet for listing the subcontractors as required is included in the proposal. The successful responsible bidder shall submit a letter to the CITY requesting approval of all subcontractors. Included in the letter shall be a list of the names and addresses of each Contractor, items to be subcontracted by item number, brief description of the item, and contract bid value. If only a portion of the item is to be subcontracted, that portion and dollar value of work, based on contract item bid value, shall be indicated.

No subcontractor shall be permitted to perform any work under the contract without having first been approved, in writing, by the CITY.

ARTICLE 6.12 TRESPASS: The Contractor shall be responsible for all damage or injury which may be caused on any property by trespass of the Contractor's employees in the course of their employment whether the said trespass was committed with or without the consent or knowledge of the Contractor.

ARTICLE 6.13 SAFETY, SANITARY AND MEDICAL REQUIREMENTS: The Contractor, his employees, his subcontractors and their employees shall promptly and fully carry out the existing safety, sanitary and medical requirements as may from time to time be prescribed by the Industrial Safety Commission and by County or State Health Departments to the end that proper work shall be done and the safety and health of the employees and of the community may be conserved and safeguarded. In case any such regulations and orders are not observed by the Contractor, they may be enforced by the Engineer at the Contractor's expense.

ARTICLE 6.14 WATER AND POWER: Unless otherwise provided in the Special Provisions, the Contractor shall provide, at his own expense, all necessary water and power required for his operations under the contract.

ARTICLE 6.15 PROTECTION OF UNDERGROUND FACILITIES: Attention is directed to the possible existence of underground facilities not known to the CITY or in a location different from that which is indicated on the plans or in these Special Provisions. The Contractor shall take steps to ascertain the exact location of all underground facilities prior to doing work that may damage such facilities or interfere with their service. If the Contractor discovers underground facilities not indicated on the Plans or in these Special Provisions, he shall immediately give the Engineer written notification of the existence of such facilities. Such facilities shall be protected from damage as directed by the Engineer and the Contractor will be paid for such work as extra work as provided in Section 7-4 "Payment for Extra Work" of the Standard Specifications.

ARTICLE 6.16 AIR POLLUTION CONTROL: Section 3-12.2, "Air Pollution Control", of the Standard Specifications is supplemented by the following:

The Contractor shall comply with all air pollution control rules, regulations, ordinances and statutes which apply to any work performed pursuant to the contract including any air pollution control rules, regulations, ordinances and statutes specified in Section 11017 of the Government Code.

In the absence of any applicable air pollution control rules, regulations, ordinances or statutes governing solvents, all solvents, including but not limited to the solvent portions of paints, thinners, curing compounds, and liquid asphalt used on the project shall comply with the applicable material requirements of the County Air Pollution Control District. All containers of paint, thinner, curing compound or liquid asphalt shall be labeled to indicate that the contents fully comply with said requirements.

Full compensation for conforming to the requirements in this article shall be considered as included in the price bid for the various contract items of work involved and no additional compensation will be allowed therefor.

ARTICLE 6.17 PROJECT APPEARANCE: The Contractor shall maintain a neat appearance to the work. In any area visible to the public, the following shall apply:

When practicable, broken concrete and debris developed shall be disposed of concurrently with its removal. If stockpiling is necessary the material shall be removed or disposed of on the next working day, except that stockpiles shall not be left in the public right of way on weekends or holidays.

Full compensation for conforming to the requirements in this article shall be considered as included in the prices bid for the various contract items of work involved and no additional compensation will be allowed therefor.

ARTICLE 6.18 FAIR EMPLOYMENT PRACTICE COMMISSION CERTIFICATION: The Contractor's attention is directed to the requirements in Section 12990 of the Government Code for nondiscrimination and compliance employment programs.

ARTICLE 6.19 SOUND CONTROL REQUIREMENTS: The Contractor shall comply with all local sound control and noise level rules, regulations and ordinances which apply to any work performed pursuant to the Contract.

Each internal combustion engine used for any purpose on the job or related to the job shall be equipped with a muffler of a type recommended by the manufacturer. No internal combustion engine shall be operated on the project without said muffler.

The noise level from the Contractor's operations between the hours of 7:00 a.m. and 4:00 p.m. shall not exceed 86 DBA at a distance of 50 feet. This requirement in no way relieves the Contractor from responsibility for complying with local ordinances regulating noise level.

Said noise level requirement shall apply to all equipment on the job or related to the job including, but not limited to, trucks, transit mixers or transient equipment that may or may not be owned by the Contractor. The use of loud sound signals shall be avoided in favor of light warnings except those required by safety laws for the protection of personnel.

Full compensation for conforming to the requirements in this article shall be considered as included in the prices bid for the various contract items of work involved and no additional compensation will be allowed therefor.

ARTICLE 6.20 LEGAL RELATIONS AND RESPONSIBILITY: The Contractor's attention is directed to the provisions of Section 5, "Legal Relations and Responsibilities", of the Standard Specifications and these Special Provisions for the requirements and conditions which he must observe in the execution of the work.

SECTION 7. PROSECUTION AND PROGRESS

ARTICLE 7.01 PROSECUTION AND PROGRESS: The Contractor's attention is directed to Section 6, "Prosecution and Progress of the Work", of the Standard Specifications.

ARTICLE 7.02 TIME LIMIT: The work specified herein and shown on the Plans and Specifications shall be completed within **fifty-five (55) working days** from the start date specified in the Notice to Proceed. Attention is directed to Section 3-13 and 6-9 of the Standard Specifications for Public Works Construction (The “Greenbook”), “Completion, Acceptance, and Warranty”; and “Liquidated Damages”. The CITY shall withhold liquidated damages before the accrual date if the anticipated liquidated damages may exceed the value of the remaining work. Liquidated damages for all work except plant establishment are as shown in the following table:

If the total amount of working days have expired and the work is not complete, liquidated damages are one thousand five hundred dollars (**\$1,500.00**) per calendar day.

SECTION 8. PAYMENTS

Within fifteen (15) workdays after the date of acceptance of the work the Engineer will cause to be filed on behalf of the CITY in the Office of the County Recorder a Notice of Completion of the work herein agreed to be done by the Contractor.

Upon expiration of forty-five (45) days after the filing of such Notice of Completion of the work, the CITY will pay to the Contractor the amount remaining after deduction from the amount of value stated in the above-mentioned estimate all prior payments to the contract and all amounts to be kept and retained under the provisions of the Contract.

If the Contractor disagrees with the Engineer’s final estimate and within said period of forty-five (45) days files a written statement of his claims, the Engineer will issue as a semi-final estimate the proposed estimate submitted to the Contractor and the CITY will within thirty (30) days pay the sum found due thereon after deducting from the amount of value stated in the first mentioned estimate all prior payments to the Contractor and all amounts to be kept and retained under the provisions of the contract. The Engineer will then consider and investigate the Contractor’s claim and will make such revision in the said estimate as he may find to be due and will then certify in writing to the City Clerk the whole amount and value of the work done by the Contractor under and according to the terms of the contract. The CITY will pay the amount so found due after deducting all previous payments, amounts to be retained under the contract, and amounts which may be retained in accordance with the applicable specifications.

ARTICLE 8.01 PARTIAL PAYMENTS: At the request of the Contractor, partial payments will be made on a monthly basis. The Progress Pay requests shall be submitted on or before the 20th day of each month. The estimate may include only work completed up to and including this date.

Progress pay requests showing work not accomplished by the 20th day of the month shall be rejected.

ARTICLE 8.02 PAY RETENTION: From each progress estimate **five percent (5%)** will be deducted and retained in accordance with Section 7-3.2 of the Standard Specifications.

ARTICLE 8.03 FINAL ESTIMATE AND PAYMENT: Whenever in the opinion of the Engineer the Contractor shall have completely performed the contract on his part the Contractor shall submit to the Engineer a written statement to the final quantities of contract items for inclusion in the final estimate.

All prior estimates upon which partial payments have been made shall be subject to correction in the final estimate. The final estimate and payments made thereunder shall be final and conclusive upon the Contractor.

ARTICLE 8.04 TAXES: No mention shall be made of sales tax or use tax, as all bid prices submitted shall be considered as including such tax.

SECTION 9. WORK SCHEDULES

ARTICLE 9.01 WORK SCHEDULE: Before the commencement of work, the Contractor shall submit a work schedule prepared using the latest version of Microsoft Project or approved equal to the Engineer for approval. The work schedule shall be submitted at least five (5) days prior to commencement of work or at the Pre-Construction Meeting, and shall be kept current through the progress of the work. The work shall be performed in order of their priorities and as directed by the Engineer.

The Contractor shall schedule his work so that all excavated locations shall be poured concrete no later than Friday. The Contractor shall not excavate any location that he is not sure that he is able to pour on Friday. No excavated location is allowed over weekends and / or holidays. The Contractor shall pay the sum of two thousand dollars (**\$2,000.00**) per each calendar day for each excavation left open and not poured concrete over the weekend starting on Saturday or over a holiday for the sidewalk portion of the work.

Full compensation for conforming to the requirements in this article shall be considered as included in the prices bid for the various contract items of work involved and no additional compensation will be allowed therefor.

SECTION 10. CITY REQUIREMENTS

ARTICLE 10.01 FAIR EMPLOYMENT PRACTICES: In connection with the performance of work under this Contract, the Contractor agrees as follows:

1. The Contractor will not willfully discriminate against any employee or applicant for employment because of race, sex, color, religion, age, handicap status, or national origin. The Contractor will take affirmative action to ensure that the applicants are employed, and that employees are treated during employment, without regard to their race, sex, color, religion, age, handicap status, or national origin. Such action shall include, but not be limited to, the following: employment upgrading, demotion or transfer; recruitment or recruitment advertising; layoff or termination; rates of pay or other forms of compensation; and selection for training, including apprenticeship. The Contractor agrees to post in conspicuous places, available to employees and applicants

for employment, notices to be provided by awarding authority setting forth the provisions of this fair Employment Practices section.

2. The Contractor will send to each labor union or representative of workers with which he has collective bargaining agreement or other contract or understanding, a notice advising the said labor union workers' representative of the Contractor's commitments under this section, and shall post copies of the notice in conspicuous places available to employees and applications for employment.
3. The Contractor will permit access to his records of employment, employment advertisements, application forms, and other pertinent data and records the Fair Employment Practices Commission, the CITY or any other appropriate agency designated by the CITY for the purposes of investigation to ascertain compliance with the Fair Employment Practices section of this Contract.
4. The finding of willful violation of the Fair Employment practices section of this Contract or of the Fair Employment Practices Act shall be regarded by the CITY as a basis for determining the Contractor to be not a "responsible bidder" as to future contracts for which such Contractor may submit bids.

The CITY shall deem a finding of willful violation of the Fair Employment Practices Act to have occurred upon receipt of written notice from the Fair Employment Practices Commission that it has investigated and determined that the Contractor has violated the Fair Employment Practices Act and has issued an order under Government Code Section 12970 or obtained an injunction under the Government Code Section 12973.

Upon receipt of such written notice from the Fair Employment Practices Commission, the CITY shall notify the Contractor that unless he demonstrates to the satisfaction of the awarding authority within a stated period that the violation has been corrected, his prequalification rating will be revoked at the expiration of such period.

5. The Contractor agrees, that should the CITY determine that the Contractor has not complied with the Fair Employment Practices section of this Contract, then pursuant to Labor Code Section 1735 and 1755, the Contractor shall, as a penalty to the Agency, forfeit for each calendar day, or portions thereof, for each person who was denied employment as a result of such non-compliance, the penalties provided in the Labor Code for violation of prevailing wage rates. Such monies may be recovered from the Contractor. The Agency may deduct any such damages from any monies due to the Contractor from the Contract.
6.
 - a. Nothing contained in this Fair Employment Practices section shall be construed in any manner or fashion so as to prevent the CITY from pursuing any other remedies that may be available by law.
 - b. Nothing contained in this Fair Employment Practices section shall be construed in any manner or fashion so as to require or permit the hiring of an employee not permitted by the National Labor Relations Act.

7. Prior to award of the Contract, the Contractor shall certify to the awarding authority that he has or will meet the following standards for affirmative compliance which shall be evaluated in each case by the CITY.
 - a. The Contractor shall provide evidence, as required by the CITY, that he has notified all supervisors, foremen and other personnel officers in writing of the content of the anti-discrimination clause and their responsibilities under it.
 - b. The Contractor shall provide evidence, as required by the CITY, that he has notified all sources of employee referrals (including unions, employment agencies, advertisements, Department of Employment) of the content of the anti-discrimination clause.
 - c. Personally, or through his representatives, the Contractor shall, through negotiations with the unions with whom he has agreements, attempt to develop an agreement which will:
 - (1) Spell out responsibilities for non-discrimination in hiring, referral, upgrading and training.
 - (2) Otherwise implement an affirmative anti-discrimination program in terms of the union's specific areas of skill and geography, to the end that qualified minority workers will be available and given an equal opportunity for employment.
 - d. The Contractor shall notify the CITY of opposition to the anti-discrimination clause by individuals, firms or organizations during the period of its prequalification.
8. The Contractor will include the provisions of the foregoing paragraphs 1 through 7 in every first tier subcontract, so that such provisions will be binding upon each such subcontractor.
9. The Contractor, in executing the proposal, thereby certifies that he has or will meet the standards for affirmative compliance with the Fair Employment Practices requirements contained herein.
10. The Contractor shall comply with the procedures and conditions set forth in Section XII of the City of La Habra Affirmative Action Plan as adopted by Resolution 2404 of the City of La Habra January 21, 1975, a portion of which reads as follows:

“It shall be the policy of the City of La Habra to require all contractors and vendors doing business with the CITY in an amount in excess of \$50,000.00 and/or 200 employees to certify their compliance with Title VII of the civil Rights Act and the Equal Employment Opportunity Act of 1972. Said certification shall be stipulated by the CITY to safeguard against discrimination by contractors or vendors on the basis of race, color, creed, sex, age, or nationality concerning the practices of recruitment, promotion, demotion, transfer, layoff, or termination. A violation of this non-discrimination certification will be considered a material provision violation and shall

be grounds for termination or suspension, in whole or in part, of the contract by the CITY”.

SECTION 11. CONSTRUCTION DETAILS

ARTICLE 11.01 GENERAL:

Subdivision 11.01.1 Description of Work: The general items of work to be performed hereunder shall be in various locations throughout the CITY, comprises the furnishing of all materials, equipment, tools, labor and incidentals and shall consist of but not be limited to

Mobilization/Demobilization; Traffic Control, Safety and Cleanup; Construction Staking and Monument Perpetuation; Storm Water Best Management Practices (BMPs); Adjust to Grade Manhole Covers, Water Valves; Unclassified Excavation and Disposal; Sawcut and Remove Existing and Construct Curb Ramp with Detectable Warning Surface; Sawcut and Remove Existing and Construct Concrete Curb and Gutter and Cross Gutter over CMB with AC Slot Trench; Construct AC Base Paving, Coldmill and Dispose of Existing Asphalt; Construct Rubberized AC pavement Overlay, Crack Seal and Slurry Seal Type II with 2.5% Latex Rubber; Traffic Striping, Crosswalks, Curb Painting, Markings, and Raised Pavement Markers; Traffic Signal Loop Detectors; Crack Sealing; and all incidental work so indicated on the specifications, and required for the proposed improvements.

Subdivision 11.01.2 Order of Work: Order of work shall conform to the provisions of Section 6-1, “Construction Schedule and Commencement of the Work,” of the Standard Specifications for Public Works Construction (The “Greenbook”) and these Special Provisions.

The Contractor shall determine the sequence of work necessary to diligently pursue completion of the work, in accordance with the Special Provisions. Work shall be phased and constructed so that at the end of each work day, excavated trenches will be covered flush to grade by steel plates or pavement, opened to traffic, and parking restored. For cold milling, the Contractor shall mill only the quantity of street that the Contractor can base pave the same working day. Open trenches adjacent to sidewalks shall be covered and protected for pedestrian traffic (such as water meters and fire hydrants). No open parkway and roadway excavation will be allowed over weekends. Sidewalks shall be ramped or filled to grade during the week.

- 1. Procurement of all materials requiring long lead-time. The Contractor shall order all long lead-time supplies, materials and equipment within ten (10) working days after the award of contract by the CITY.**
- 2. Develop and set up traffic control measures.**
- 3. Install initial project storm water pollution prevention plan and BMPs.**
- 4. Complete all required excavation.**
- 5. Complete all backfill, compaction, T-cuts, AC cap and pavement restoration.**
- 6. Complete all concrete improvements.**
- 7. Complete all street improvements.**
- 8. Adjust surface utilities and manholes to grade.**

9. Complete signing, striping, pavement markings and traffic loops.

Subdivision 11.01.3 Public Convenience and Access: The Contractor shall conduct his operations so as to cause minimum obstruction and inconvenience to the public.

At least ten (10) days prior to commencing work, the Contractor shall submit to the Engineer his construction schedule for approval in accordance with Section 9. This schedule shall allow businesses and residents on the affected streets to park within a reasonable distance from their business or home. The Contractor shall distribute to each resident or business affected by the construction a written notice at least 7 calendar days prior to commencing construction. The Contractor shall notify residents and businesses of the work and post temporary "No Parking" signs. The notice shall include the date and working hours of construction. It shall be the Contractor's responsibility to complete the notification letter with the proper dates at the time of notification. If the Contractor fails to meet the schedule indicated in the Notice, the Contractor shall reschedule his work and re-notify the residents. Request for changes shall be submitted by the Contractor to the Engineer for approval at least 10 working days in advance and residents shall be re-notified 7 calendar days prior to commencing construction.

Continuous emergency and local traffic access shall be maintained in the area of work and vehicular access to individual driveways shall be provided and maintained except for short durations of not more than two hours and with prior notice to the adjacent residents involved. No overnight closure of driveways will be allowed except while construction is in progress and concrete is curing. The Contractor shall provide alternate ramps for access while concrete is curing, where feasible.

Should the Contractor appear to be neglectful or negligent in furnishing warning and protective measures, the Engineer may direct the Contractor's attention to the existence of such hazards. The Contractor shall provide all necessary warning and protective measures immediately, at his expense. Whether the Engineer points out the inadequacy of warning and protective measures or not, such action, or lack of action, on the part of the Engineer shall not relieve the Contractor from the responsibility for public safety or abrogate his obligation to furnish and pay for safety measures and devices. If attention is directed to the existence of a hazard, and the Contractor fails to provide an appropriate remedy, any expense incurred by the CITY for furnishing or maintaining safety measures and devices may be deducted from the pay estimates and the total contract price for the work.

The Contractor shall maintain access for residents at all times during the construction and at the end of each work day as specified above. The travel lanes shall be graded smooth and shall be maintained in a smooth condition throughout the period of construction including weekends, and at times as directed by the Engineer.

The Contractor shall be responsible for maintaining location of, and access to, all utilities and underground facilities during construction operations, including but not limited to valves and monitoring wells.

Subdivision 11.01.4 Public Notice: The Contractor shall notify businesses and residents affected by the construction in writing not less than 7 calendar days advance of commencement of demolition, construction, or storage of materials in the street. The notice shall include but not be limited to:

1. Time and Date of Commencement.
2. Working Hours of Construction.
3. Date of Completion.
4. Name & Telephone Number of Person to be Contacted, at any hour, in the event of a condition requiring immediate correction.

A copy of the letter shall be submitted to the City Engineer for approval prior to distribution.

The Contractor shall also notify La Habra Police Department, Los Angeles County Fire Department, Trash Hauler, Post Office, Ambulance Service, La Habra City School District, Las Positas Elementary School, Imperial Middle School, and Orange County Transportation Authority about the construction. It shall be the Contractor's responsibility to complete the notification letter, with the proper dates, at the time of notification. If the Contractor fails to meet the schedule indicated in the Notice, the Contractor shall reschedule his work and re-notify all those listed above.

Subdivision 11.01.5 Hours of Work: All work shall be performed between 7:00 A.M. and 4:00 P.M., Mondays through Fridays except holidays. No work shall be performed outside normal working hours without advanced authorization from the Engineer. If work is adjacent to a school or on a major arterial, working hours will be restricted to 9:00 A.M. and 3:00 P.M. for lane closures, Mondays through Fridays except holidays. For any inspection outside of regular working hours, the Contractor shall pay all costs for the inspector's time. Request for overtime inspection shall be made in writing to the Engineer.

Full compensation for conforming to the requirements in this article shall be considered as included in the prices bid for the various contract items of work involved and no additional compensation will be allowed therefor.

ARTICLE 11.02 FURNISH AND APPLY WATER: Should the Contractor require water for construction operations, such as for compaction and dust control, he may use water from any fire hydrant adjacent to the job site upon application of a "No Fee" permit from the CITY, Engineering Department. The Contractor shall apply water for dust control as necessary and as directed by the Engineer.

Prior to using water, the Contractor shall install a water meter, a valve and an approved back-flow prevention device on the fire hydrant at his expense. The Contractor shall notify Los Angeles County Fire Department and the Public Works Department twenty-four (24) hours in advance, stating the location of the hydrant and the hours when it will be used. The Contractor shall operate the fire hydrant with a hydrant wrench only. Should damage occur to the hydrant, the Contractor shall make repairs at his expense and/or further use of CITY Water may be prohibited. The meter

will be used for monitoring water use only. The Contractor will not be charged for water used on the project.

Full compensation for conforming to the requirements in this article shall be considered as included in the prices bid for the various contract items of work involved and no additional compensation will be allowed therefor.

ARTICLE 11.03 DUST CONTROL: The Contractor shall at all times, including weekends, at his expense, control dust on the project. Should the Contractor fail to maintain adequate dust control, the CITY will maintain the site, and an amount equal to twice the actual cost shall be assessed to the Contractor.

Full compensation for conforming to the requirements in this article shall be considered as included in the prices bid for the various contract items of work involved and no additional compensation will be allowed therefor.

ARTICLE 11.04 EXCESS EXCAVATED MATERIAL: Excess excavated material shall be removed from the site and disposed of by the Contractor at his own expense. Excavated material including pavement, base, rock and subgrade soils, shall be removed from the job site at the end of the workday. Failure to do so will result in the CITY removing material at the Contractor's expense. Cost shall be calculated at actual cost for labor and equipment plus administrative charges.

Full compensation for conforming to the requirements in this article shall be considered as included in the prices bid for the various contract items of work involved and no additional compensation will be allowed therefor.

ARTICLE 11.05 STORAGE OF MATERIALS: The Contractor shall at all times carefully and properly protect all materials of every description both before and after being used in the work and provide any enclosing or special protection from the weather as deemed necessary by the Engineer.

Full compensation for conforming to the requirements in this article shall be considered as included in the prices bid for the various contract items of work involved and no additional compensation will be allowed therefor.

ARTICLE 11.06 SOLID WASTE COLLECTION: If collection of solid waste shall occur during street construction, the Contractor shall assist the solid waste collection contractor in accessing containers for his collection of solid waste.

Full compensation for conforming to the requirements in this article shall be considered as included in the prices bid for the various contract items of work involved and no additional compensation will be allowed therefor.

ARTICLE 11.07 APPURTENANT WORK: All items in the proposal form are considered as complete in place including all incidental and appurtenant work and materials necessary for the satisfactory completion of the same.

Full compensation for conforming to the requirements in this article shall be considered as included in the prices bid for the various contract items of work involved and no additional compensation will be allowed therefor.

ARTICLE 11.08 STORAGE YARD: The Contractor shall at his expense provide a storage yard for his equipment, tools, and materials to be stored. Location of storage yard shall be approved by the Engineer. CITY streets are not to be used as a storage area/yard.

Full compensation for conforming to the requirements in this article shall be considered as included in the prices bid for the various contract items of work involved and no additional compensation will be allowed therefor.

ARTICLE 11.09 PUBLIC UTILITIES: It is the Contractor's responsibility to notify Underground Service Alert (USA) to locate facilities prior to beginning the work. In addition, the Contractor shall locate service laterals that may be affected by the work and take measures to protect all utilities and service laterals in the streets and parkways.

The Contractor shall determine for himself the exact location of all public and private utilities, facilities or substructures, which are not shown on the plans. In the event any utility, facility or substructure is disturbed or damaged, whether in its original or relocated position, the Contractor shall immediately cause repairs to be made to the satisfaction of the owner at no cost to the CITY.

The Contractor shall notify the utility companies at least forty-eight (48) hours prior to construction.

| | | |
|---------------------------------------|--------------------|----------------|
| AT&T | YVETTE GAROFANO | (714) 618-9146 |
| CALIFORNIA DOMESTIC WATER COMPANY | CHE VENEGAS | (562) 947-3811 |
| CHEVRON USA | DAVE ZERLER | (310) 669-4014 |
| CITY OF LA HABRA PARKS DEPT | DAVID VILLALBA | (562) 383-4170 |
| CITY OF LA HABRA SEWER AND WATER DEPT | BRIAN JONES | (562) 383-4170 |
| COMCAST CABLE COMPANY | | (800) 501-5738 |
| CRIMSON PIPELINE | APRIL HARVEY | (562) 285-4195 |
| CR&R (WASTE HAULER) | | (714) 372-8209 |
| FRONTIER COMMUNICATIONS | ARIEL FATALA | (714) 375-6717 |
| KINDER MORGAN | DON QUINN | (714) 560-4400 |
| LA HABRA HEIGHTS WATER COMPANY | | (562) 697-6769 |
| METROPOLITAN WATER DISTRICT | MATT PARRY | (714) 577-5084 |
| MOBIL OIL | RUTH CRONIN-FRUITT | (310) 212-1761 |

| | | |
|-----------------------------------|------------------|----------------|
| ORANGE COUNTY SANITATION DISTRICT | DANIEL LEE | (714) 593-7176 |
| PLAINS ALL AMERICAN PIPELINE | JOE MATTEO | (562) 728-2368 |
| SO CAL EDISON | JIMMY PARKIN | (714) 578-3434 |
| SO CAL GAS | JASON MORTON | (213) 312-5735 |
| SHELL PIPE COMPANY | MALDONADO | (310) 816-2063 |
| SPECTRUM | PARKER YEE | (562) 677-0213 |
| SUBURBAN WATER SYSTEMS | TOM MEDINA | (562) 755-5015 |
| TORRANCE LOGISTICS COMPANY | TERI A. SHINDE | (310) 212-1794 |
| UNOCAL | ARNA ADAMS | (213) 864-5663 |
| WESCON C/O VINTAGE PRODUCTION | EMILIO RODRIGUEZ | (562) 665-9255 |
| UNDERGROUND SERVICE ALERT | | (800) 422-4133 |

Full compensation for conforming to the requirements in this article shall be considered as included in the prices bid for the various contract items of work involved and no additional compensation will be allowed therefor.

ARTICLE 11.10 RESTORATION OF IMPROVEMENTS: The Contractor shall restore the construction site per the Greenbook (SSPWC) Section 7-9. All damage done to existing facilities and improvements by the Contractor shall be repaired by him to the satisfaction of the Engineer. All paint marks shall be removed at the end of the project by using an approved blasting method.

Lawn areas disturbed by the construction area shall be graded smooth and level with the adjacent lawn. All dirt clumps greater than one inch in size shall be crumbled or removed and all stone or rock shall be removed. The disturbed area shall be replaced with sod of a variety similar to the adjacent lawn. Shrubs destroyed or removed shall be replaced in kind to the satisfaction of the adjacent property owner. Paved areas shall be restored in kind to the satisfaction of the adjacent property owner. All fences disturbed, damaged or removed shall be restored to the satisfaction of the Engineer. In areas of close quarters the Contractor shall excavate by hand. Facilities damaged by using power tools shall be replaced to the satisfaction of the adjacent property owner. Cement concrete sidewalks removed or damaged shall be saw-cut and removed to the nearest score mark and replaced in accordance with CITY Standard Detail R-14. Any other improvements disturbed shall be restored to its original conditions and to the satisfaction of the adjacent property owner. Sprinklers and irrigation lines disturbed by the construction operations shall be restored to their original condition or better to the satisfaction of the adjacent property owner and/or Engineer.

Full compensation for conforming to the requirements in this article shall be considered as included in the prices bid for the various contract items of work involved and no additional compensation will be allowed therefor.

ARTICLE 11.11 WASTE MANAGEMENT: The Contractor shall comply with the requirements of AB939 and City of La Habra Construction and Demolition Ordinance, and submit a Waste Management Plan for the approval of the Engineer.

Full compensation for conforming to the requirements in this article shall be considered as included in the prices bid for the various contract items of work involved and no additional compensation will be allowed therefor.

ARTICLE 11.12 BID SCHEDULE: The quantities and sizes of materials shown in the bid schedule are for bid purposes only. The actual quantities used for construction and payment purposes shall be measured and determined by the CITY.

ARTICLE 11.13 EARTHWORK: Earthwork shall conform to the requirements of Section 300, "Earthwork" of the Standard Specifications and shall include all clearing and grubbing, demolition, saw-cut, excavation, grading, removal, disposal, backfilling or any other work necessary to prepare the sub-grade for construction of improvements.

Subdivision 11.13.1 Clearing and Grubbing: Clearing and grubbing shall conform to the applicable portions of Section 300, "Earthwork" of the Standard Specifications. All PCC and asphalt concrete to be removed shall be sawcut as needed to provide straight clean joints.

The tasks included as part of clearing and grubbing include the following:

1. Removal and restoration, replacement or relocation of fences, planters, foundations, walls, vegetation and irrigations systems not included as part of other bid items.
2. Protection of existing utilities, trees, fences, walls, signs and other facilities within the construction zone, except those directed to be removed or relocated.
3. Root pruning of tree roots and their disposal in areas where roots are causing lifting of existing concrete improvements. Work is to be as advised by the City Arborist.

Full compensation for conforming to the requirements in this article shall be considered as included in the prices bid for the various contract items of work involved and no additional compensation will be allowed therefor.

ARTICLE 11.14 TRENCHING: (Public Contracts Code §7104) If the herein public works contract involves digging trenches or other excavations that extend deeper than four feet below the surface the Contractor shall promptly, and before the following conditions are disturbed, notify the local public entity, in writing, of any:

- (1) Material that the Contractor believes may be material that is hazardous waste, as defined in Section 25117 of the Health and Safety Code, that is required to be removed to a Class I, Class II, or Class III disposal site in accordance with provisions of existing law.
- (2) Subsurface or latent physical conditions at the site differing from those indicated by information about the site made available to bidders prior to the deadline for submitting bids.
- (3) Unknown physical conditions at the site of any unusual nature, different materially from those ordinarily encountered and generally recognized as inherent in work of the character provided for in the contract.
- (4) The CITY shall promptly investigate the conditions, and if it finds that the conditions do materially so differ, or do involve hazardous waste, and cause a decrease or increase in the

Contractor's cost of, or the time required for, performance of any part of the work shall issue a change order under the procedures described in the contract.

- (5) That in the event that a dispute arises between the CITY and the Contractor whether the conditions materially differ, or involve hazardous waste, or cause a decrease or increase in the Contractor's cost of, or time required for, performance of any part of the work, the Contractor shall not be excused from any scheduled completion date provided for by the contract, but shall proceed with all work to be performed under the contract. The Contractor shall retain any and all rights provided either by contract (Section 6.01.6 of the herein Special Provisions) or by law which pertain to the resolution of disputes and protests between the contracting parties.

Trench excavation shall include, without classification, the removal of all materials of whatever nature encountered, including all asphalt or other obstructions of every nature that would interfere with the proper execution and completion of the work. The Contractor shall furnish, place and maintain all supports and shoring as set forth in the rules, orders and regulations of the Division of Industrial Safety of the State of California. The Contractor shall supply all pumping, ditching or other approved measure to effect the removal or exclusion of water, storm water and/or wastewater reaching the site of the work from any source so as to prevent damage to the work.

Full compensation for conforming to the requirements in this article, including but not limited to all saw cutting, trench excavation, moving and proper disposal of the excavated material, disposal fees, pumping, shoring, backfill, pipe zone material, backfill material, temporary AC pavement and related items shall be considered as included in the prices bid for the various contract items of work involved and no additional compensation will be allowed therefor.

ARTICLE 11.15 PUMPING: All excavations shall be kept free of water while concrete or pipe is being placed and until concrete has attained its initial set to eliminate any possible damage from such water. Any water accumulations in excavations from any source whatsoever shall be removed by the Contractor at his own expense. Wastewater shall be removed with a vacuum truck and disposed of offsite in such a manner that it will not cause any damage to public or private property or will not be a menace or inconvenience to the public. This article does not construe that groundwater is present. Field investigations have not been made to obtain water table depth.

Included as part of this article is removal and proper disposal of removed materials.

Full compensation for conforming to the requirements in this article shall be considered as included in the prices bid for the various contract items of work involved and no additional compensation will be allowed therefor.

ARTICLE 11.16 BACKFILLING AND COMPACTING: All excavations shall be backfilled to the level of the original ground surface unless otherwise shown on the plans or ordered by the Engineer.

Backfill around valve and valve box clusters shall be accomplished with sand (SE 30 or greater). The sand backfill shall be compacted by jetting. The trench, for a distance of five (5) feet each side of the valve box shall be filled with sand and compacted.

The trench shall be backfilled to a level six inches above the top of pipe with 1.5 sack sand-cement slurry. The remaining backfill shall be placed in horizontal layers per detail included herein. Each layer shall be moistened, tamped, puddled, rolled or otherwise compacted to maximum density per Greenbook requirements. The sand equivalent shall be certified by the Contractor.

Full compensation for conforming to the requirements in this article shall be considered as included in the prices bid for the various contract items of work involved and no additional compensation will be allowed therefor.

ARTICLE 11.17 SAND CEMENT SLURRY BACKFILL: 1.5 sack sand cement slurry backfill shall be placed at all tunnels and other locations that are impractical to achieve base compaction. Slurry shall be placed from top of bedding material to bottom of pavement surface.

Full compensation for conforming to the requirements in this article shall be considered as included in the prices bid for the various contract items of work involved and no additional compensation will be allowed therefor.

SECTION 12: BID ITEMS FOR MONTE VISTA STREET REHABILITATION PROJECT, FISCAL YEAR 2022-2023, CITY PROJECT NO. 2-R-22:

ARTICLE 12.01: MOBILIZATION/DEMOBILIZATION: Mobilization/Demobilization shall include all labor, work, and materials necessary to mobilize and demobilize forces, equipment, and materials; obtain bonding, insurance, permits, licenses, attend meetings; and other work as necessary to prepare for the construction of the work. Compensation for Mobilization shall not exceed **Five Percent (5%)** of the total bid amount.

Union Pacific Encroachment Permit Requirement: Mobilization/demobilization shall also include all labor, work, insurance, permit fees necessary to execute a contractor endorsement permit application (See Appendix C for further detail) with Union Pacific Railroad (UPRR). The contractor shall obtain and meet insurance requirements of UPRR, pay all fees including \$1,025 contractor endorsement administration fee, submit traffic control plans and obtain UPRR approval, hire certified railroad flaggers approved by UPRR, obtain badging, attend all required meetings, and satisfy any and all requirements set forth by UPRR to execute UPRR permit and allow for work in Union Pacific Railroad Right of Way.

Full compensation for obtaining UPRR encroachment permit and all satisfy all requirements set forth by UPRR shall be considered included with MOBILIZATION/DEMOBILIZATION and no additional compensation will be allowed therefor.

Utility Encroachment, Permits, Safety, and Construction requirements:

Mobilization/demobilization shall also include all labor, work, insurance, any permit fees necessary to encroach upon utility easements and comply with requirements prior and during construction. Contractor shall meet with utility as required by the utility companies prior to construction and satisfy requirements set forth by utility companies at no additional cost to the City. Pertinent utility companies this include, but not limited to, Kinder Morgan, Southern California Gas Company, Crimson Pipeline, Orange County Flood Control District, Metropolitan Water District, La Habra Heights County Water District, and any other utilities as deemed necessary. Metropolitan Water District, Orange County Flood Control District will require the contractor to provide insurance certificates to encroach upon their right of way, and providing said insurance is considered included in mobilization/demobilization. Contractor shall also provide insurance to any other utilities that require insurance and no additional cost to the City. (See Appendix D for further details)

Full compensation for complying with utility encroachment, permits, safety, and construction requirements shall be considered included with MOBILIZATION/DEMOBILIZATION and no additional compensation will be allowed therefor.

Full compensation for complying with the work contained in this article for MOBILIZATION/DEMOBILIZATION (BID ITEM 1) shall be considered included in the contract bid price per Lump Sum (LS), and no additional compensation will be allowed therefor. One half of the bid amount shall be paid upon completion of at least ten percent (10%) of the work. One half shall be paid upon completion of the work, punch-list items, and complete cleanup and

restoration of the project site. Compensation for Mobilization shall not exceed **Five Percent (5%)** of the total bid amount.

ARTICLE 12.02: TRAFFIC CONTROL, SAFETY, AND CLEANUP: The Contractor is directed to Subdivision 11.01.3 “Public Convenience and Access” and Subdivision 11.01.4 “Public Notice” as part of this article. The Contractor shall be responsible for adequate barricading of the work area and controlling of traffic in the vicinity of the project as specified in Section 5-7 “Safety” in the Standard Specifications and these Special Provisions or as directed by the Engineer. Compensation for Traffic Control, Safety, and Cleanup shall not exceed **Five Percent (5%)** of the total bid amount.

The Contractor’s operations shall cause no unnecessary inconvenience. The access rights of the public shall be considered at all times. Unless otherwise authorized, traffic shall be permitted to pass through the Work, or an approved detour shall be provided.

Prior to construction, the Contractor shall submit to the Engineer for approval, a traffic control plan and a construction phasing plan. The traffic control plan shall include, but not be limited to, location of all temporary signs, barriers, flashing arrow boards and proposed traffic flow diagrams. The information shall include the minimum requirements of the State of California Manual of Uniform Traffic Control Devices (MUTCD), latest edition. The TCP shall be signed and stamped by either a Traffic Engineer (T.E.) or Professional Civil Engineer (P.E.), registered in the State of California and submitted by the Contractor to the CITY for approval.

The Contractor shall furnish at his expense and with no extra cost to the CITY such flagmen and guards as are necessary to give adequate warning to the public that roadway work is underway and of any dangerous conditions to be encountered. Flagmen shall perform their duties and be provided with equipment in accordance with current “Instructions to Flagmen” of the State of California, Division of Highways. The equipment shall be furnished, kept clean and in good repair by the Contractor at his own expense. The Contractor shall furnish, erect, maintain and regularly inspect barricades, lights, signs and other devices as are necessary to prevent accidents and avoid damage or injury to the public. These devices shall conform to the requirements set forth in the current “Manual of Warning Signs, Lights and Devices for Use in Performance of Work Upon Highways”, issued by the State of California, Department of Transportation or State of California Manual of Uniform Traffic Control Devices (MUTCD), latest edition.

Union Pacific Railroad (UPRR) Requirement: The contractor will need to submit traffic control plans for review and approval by UPRR and hire railroad flagmen from a specific vendor approved by UPRR for traffic control in UPRR right of way. The contractor shall pay all expenses associated with UPRR permit requirements and hiring of UPRR approved flagmen; the compensation for this task is included as part of MOBILIZATION/DEMOBILIZATION (Bid Item 1) and no additional compensation will be allowed therefor.

All traffic control devices (delineators, signs, etc.) must be picked up at the end of the workday and stored off-site at an approved location. Traffic control devices may not be left overnight in the medians, at the curb, on sidewalks, etc. All graffiti on construction traffic control devices (delineators, signs, etc.) must be removed daily, or the signs be replaced.

Traffic control shall limit travel on only the specific work area for each day.

The roadway shall have at least one lane open in both directions at all times.

Parking shall be restricted only as needed for the specific work area for each day, and shall be reopened at the end of each work day. Parking restrictions may be from 7:00 AM to 4:00 PM on working days.

Through lanes and parking shall be restored by 4:00 PM each working day.

Trench plates shall be H20 load rated, skid resistant, and shall have traffic markings as needed to designate existing lane lines.

Before excavating through traffic loops, Contractor shall notify the CITY and have the signal placed on timed cycles. Loops shall be restored as soon as practicable.

Closures and parking restrictions shall only be made for the amount of time necessary to complete construction activities. Areas that do not have active construction work shall be secured and reopened as directed by the Engineer. Extents of closures and parking restrictions shall be limited to areas as necessary for immediate construction activities. Contractor shall install temporary “No Parking” and “Tow Away” signs.

When necessary to provide vehicular or pedestrian crossings over the fresh pavement, the Engineer shall direct the Contractor to spread sufficient sand or rock dust on the affected area to eliminate tracking or damage to the slurry. Sand or rock dust used for this purpose shall be at the Contractor’s expense.

Safe and adequate pedestrian and vehicular access shall be provided and maintained to: fire hydrants; commercial and industrial establishments; churches, schools, and parking lots; service stations and motels; hospitals; police and fire stations; and establishments of similar nature. Access to these facilities shall be continuous and unobstructed unless otherwise approved by the Engineer.

Safe and adequate pedestrian zones and public transportation stops, as well as pedestrian crossings of the Work at intervals not exceeding 300 feet in each direction, shall be maintained unless otherwise approved by the Engineer. Contractor shall not disturb two consecutive transportation stops.

Vehicular access to residential driveways shall be maintained to the property line except when necessary construction precludes such access for reasonable periods of time. If backfill has been completed to the extent that safe access may be provided, and the street is opened to local traffic, the Contractor shall immediately clear the street and driveways and provide and maintain access.

The Contractor shall provide temporary AC ramps where there are differences at removals and/or cold mills. Ramps shall be provided in advance of opening the lane to vehicular travel.

Grading operations, roadway excavation and fill construction shall be conducted by the Contractor in a manner to provide a reasonably satisfactory surface for traffic. When rough grading is completed, the roadbed surface shall be brought to a smooth, even condition satisfactory for traffic.

Unless otherwise authorized, work shall be performed in only one-half the roadway at one time. One half shall be kept open and unobstructed until the opposite side is ready for use. If one-half a street only is being improved, the other half shall be conditioned and maintained as a detour.

Contractor shall include the scheduling and required Traffic Control & Construction Phasing for all resurfacing work. The contractor shall distribute notices with the resurfacing schedule to the impacted properties seven (7) calendar days prior to resurfacing operations. Contractor shall also post "No Parking" signage seventy-two (72) hours prior to the intended resurfacing work. The signage will provide the date and time that vehicles are prohibited from on street parking.

Solar/battery powered Changeable Message Signs (CMS) shall be placed in advance of the project, at each end of the project segments, two (2) CMS total will be required for the project. The CITY shall direct the Contractor on the language of the message. The CMS shall be installed a minimum of one (1) month before the project starts, and the CITY has the right to make changes to the message at any time and at no additional cost to the CITY.

The Contractor shall cooperate with the various parties involved in the delivery of mail, residents attempting to enter or exit, and the collection and removal of trash and garbage to maintain existing schedules for these services.

Full compensation for conforming to the requirements in this article TRAFFIC CONTROL, SAFETY, AND CLEANUP (BID ITEM 2) shall be considered as included in the contract bid price per Lump Sum (LS), and shall include all labor, tools, materials and appurtenances necessary to complete the work and no additional compensation will be allowed therefor. Compensation for Traffic Control, Safety and Cleanup shall not exceed **Five Percent (5%)** of the total bid amount.

ARTICLE 12.03: CORNER RECORDS, CONSTRUCTION STAKING AND MONUMENT PERPETUATION: The Contractor shall provide all labor, tools, work, materials and appurtenances necessary to survey the work to conform to plan lines and limits, provide grades for drainage, establish pavement grades, match to existing conditions, and otherwise lay out the work as necessary for construction. The Contractor shall review and set all reference points, grades and elevations to the satisfaction of the Engineer prior to construction operations.

Pavement grades shall be provided as necessary for PCC construction, and to prepare the street for asphalt pavement operations. Grades shall provide for adequate drainage, match to existing slopes, gutters and other improvements, and provide a smooth profile. Nominal pavement grades shall be 2% from the pavement centerline to edge of gutter. In locations where gutter elevations differ on each side of the street, the slope shall be adjusted to provide adequate drainage, but shall not be less than 1% or more than 4%, and shall be approved by the Engineer.

Prior to the start of construction, the Contractor's licensed Land Surveyor or registered Civil Engineer licensed to practice land surveying in the State of California shall, in conformance with California State Law AB 1414, locate all monuments (whether or not of record), bench marks, and centerline ties within the construction zone, i.e., within one hundred feet of the construction activity. Additional ties to monuments shall be set when ties are missing (min. 4 ties per monument.) The Contractor's Licensed Surveyor or qualified Civil Engineer shall prepare and submit for review to the Engineer separate tie sheets and Corner Record sheets (monuments not of record shall have only tie sheets prepared). Tie sheets and Corner Records shall conform to the County Standards and the County Engineers' Association of California's "Guide to the Preparation of Records of Survey and Corner Records" document as provided by the County of Orange Land Surveyor's Office. Upon review by the Engineer, the Land Surveyor shall file the Corner Records with the County of Orange Land Surveyor's Office as required by law, and file Certified Corner Records with the City Engineer.

After construction and prior to final acceptance by the CITY of the construction project, the Contractor's land surveyor or qualified Civil Engineer shall re-survey all field monuments and centerline ties within the construction zone, prepare tie sheets and Corner Record sheets as indicated above, and file them with the City Engineer for review. After review by the City Engineer, the land surveyor shall file the Corner Records with the County of Orange Land Surveyor's Office as required by law, and file certified copies of the Corner Records with the City Engineer.

The Contractor shall not disturb any monuments, stakes or sign posts found on the line of the improvement until authorized by the Engineer. The Contractor shall bear the expense of resetting any monument, stakes or sign posts which may be disturbed without authorization from the Engineer. All survey monuments removed or altered as a result of construction shall be reset, Corner Records filed with the County of Orange Land Surveyor's Office, and approved final Corner Records filed with the City Engineer. Centerline ties removed as a result of construction shall be reset and tie sheets filed with the City Engineer.

The Contractor is responsible to re-establish any survey monument that is disturbed, including monuments at the property line with no extra cost to the CITY to the satisfaction of the City Engineer.

The land surveyor shall provide a letter of certification for all monuments having four or more existing ties which are within 0.02 feet plus or minus of the original CITY tie sheet records. When several monuments or ties appear on one tie sheet and one of the ties has changed, the land surveyor shall re-measure all of the ties and re-file a new tie sheet with the CITY as required herein.

County of Orange permanent and temporary bench marks within the construction zone shall be located by survey, and the Contractor's Land Surveyor shall send a written notification of impending construction to the County of Orange Land Surveyor's Office two weeks prior to construction.

Lines and grades for the construction shall be the responsibility of the Contractor, with the following provisions:

All work under this contract shall be built in accordance with the lines and grades shown on the plans. Field survey for establishing these, and for the control of construction, shall be the responsibility of the Contractor. All such survey work including construction staking shall be done under the supervision of a California Licensed Land Surveyor or authorized Civil Engineer. Staking shall be done on all items ordinarily requiring grade and alignment, at intervals normally accepted by the agencies and trade involved.

The Contractor shall provide a copy of the office calculations and grade sheets to the Engineer. The Contractor shall be responsible for any errors in the finished work, and shall notify the Engineer, in writing, within twenty-four (24) hours, of any discrepancies, or design errors during the construction staking.

Contractor shall provide construction surveying for relocation of any conflicting utilities and provide a reasonable time window of opportunity to the utility owners to relocate their facilities after the survey is provided by the Contractor.

Construction shall not begin until the Preliminary Corner Records are submitted to the City.

Project retention will not be released until all records are recorded with the County of Orange Land Surveyor's Office.

Full compensation for conforming to the requirements in this article CORNER RECORDS, CONSTRUCTION STAKING AND MONUMENT PERPETUATION (BID ITEM 3) shall be considered as included in the contract bid price for the project, and shall include, but not be limited to, construction staking, location and/or relocation of conflicting utilities, locating survey monuments, setting of survey monuments and center lines ties, preparing and filing centerline tie sheets and Corner Records, locating bench marks and notifying the County Surveyor's Office of same, professional office services and field calculation, and furnishing all labor, tools, materials, equipment and appurtenances necessary to complete the work and no additional compensation will be allowed therefor.

ARTICLE 12.04: STORM WATER BEST MANAGEMENT PRACTICES (BMPs): The Contractor shall comply with Section 3-12 "Work Site Maintenance" of the Standard Specifications for Public Works Construction. The Contractor shall not permit polluted water to enter a catch basin or drainage channel. Water pollution control work shall consist of constructing those facilities which may be shown on the Plans, specified elsewhere in these Special Provisions, required by the Standard Specifications, required by National Pollutant Discharge Elimination System (NPDES No. CAS000002) California General Permit for Storm Water Discharges Associated with Construction and Land Disturbance Activities Order No. 2009-0009-DWQ, or ordered by the Engineer. Said work is intended to provide prevention, control and abatement of water pollution to streams, waterways and other bodies of water.

In order to provide effective and continuous control of water pollution, it may be necessary for the Contractor to perform the contract work in small or multiple units on an out-of-phase schedule and

with modified construction procedures. The Contractor shall provide temporary pollution control measures including, but not limited to, dikes, basins, ditches and the application of straw and seed which become necessary as a result of his operations. The Contractor shall coordinate water and pollution control work with all other work done on the contract.

Before starting any work on the project, the Contractor shall submit to the Engineer for acceptance a Water Pollution Control Plan (WPCP) for effective control of water pollution. Such WPCP shall show the schedule for the erosion control work included in the contract and for all water pollution control measures which the Contractor proposes to take in connection with construction of the project to minimize the effect of his operations upon adjacent streams and other bodies of water. The Contractor shall not perform any clearing and grubbing, or earthwork on the project, other than that specifically authorized in writing by the Engineer, until such WPCP has been accepted. The Contractor shall revise and bring up to date said WPCP at any time the Engineer makes written request for such revision.

The Engineer will notify the Contractor of the acceptance or rejection of any submitted or revised WPCP in not more than ten (10) days.

The CITY shall not be liable to the Contractor for failure to accept all or any portion of an originally submitted or revised WPCP, nor for any delays to the work due to the Contractor's failure to submit an acceptable WPCP.

The Contractor may request the Engineer to waive the requirement for submission of a written WPCP for control of water pollution when the nature of the Contractor's operation is such that erosion is not likely to occur. Waiver of this requirement will not relieve the Contractor from responsibility for compliance with the other provisions of this section. Waiver of the requirement for a written WPCP for control of water pollution will not preclude submittal of a written WPCP at a later time if the Engineer deems it necessary because of the effect of the Contractor's operations.

Where erosion control damage will cause water pollution which is probably due to the nature of the material or the season of the year, the Contractor's operations shall be so scheduled that permanent erosion control features will be installed concurrently with or immediately following grading operations.

Compliance with the requirements of this article shall in no way relieve the Contractor from his responsibility to comply with the other provisions of the Contract, in particular, his responsibility for damage and for preservation of property.

All water pollution control work performed in accordance with the accepted WPCP which is not otherwise required under the contract and which is ordered by the Engineer will be paid for as follows:

- (1) Such water pollution control work which may be accomplished under the various contract items of work will be measured and paid for as provided for in these Special Provisions for the said items of work.

- (2) Such water pollution control work not covered by contract items will be paid for as extra work as provided for in Section 7-4 “Payment for Extra Work” of the Standard Specifications.

Except as otherwise provided in this Article 12.04, or in the Standard Specifications or elsewhere in these Special Provisions, full compensation for complying with the work contained in this article for STORM WATER BEST MANAGEMENT PRACTICES (BMPs) (BID ITEM 4) shall be considered included in the contract bid price per Lump Sum (LS), and no additional compensation will be allowed therefor.

ARTICLE 12.05: TRAFFIC SIGNING, STRIPING, PAVEMENT MARKERS AND PAVEMENT MARKINGS: This bid item shall include all labor, tools, materials and appurtenances necessary to install traffic signing, striping, pavement markers and pavement markings. The Contractor shall document all existing striping and pavement markings, curb paint, curb addresses, and raised pavement markers for areas which will be removed during construction. Contractor shall lay out and install new striping and markings to replace existing striping and markings, including painted curb and curb addresses where such have been removed due to construction, and raised pavement markers, including the installation of blue reflective raised pavement markers at all fire hydrant locations. Contractor shall document all red and green curbs prior to construction and repaint all red and green curbs after construction.

The materials for traffic paint shall be from the listed waterborne paint conforming to the Caltrans Standard Specifications (latest edition), Section 84-2; and the applicable provisions of the Standard Specifications for Public Works Construction “Greenbook” (latest edition). Raised pavement markers shall conform to the Caltrans Standard Specifications (latest edition), Section 85, and the Caltrans Standard Plans (latest edition).

Striping and Markings shall be painted (two coats of paint with reflective beads), unless otherwise shown, and shall be placed per Caltrans Standard Specification Section 84: Traffic Stripes and Pavement Markings. Paint, beads, and raised pavement markers shall be approved by the Engineer. The work shall include surface preparation, layout, material placement, curing, protection, testing, traffic control and all other work necessary to install the striping and markings, curb paint and addresses, and raised pavement markers. Paint coats shall be installed a minimum of 7 days apart.

Glass beads shall be applied to pavement markings, crosswalks, and striping by a dispensing device developed for this purpose or other methods approved by the Engineer. Streets and surrounding areas are to be kept clean of excess beads.

The Contractor shall furnish the necessary control points for replacement of all striping and markings and shall be responsible for the completeness and accuracy thereof to the satisfaction of the Engineer. No striping or markings shall be installed until the layout has been specifically approved by the Engineer.

Spotting shall be completed prior to the installation of any striping and markings.

After completion of paving, the Contractor shall install two-way blue raised reflectors on the pavement two (2) feet from centerline of the street (hydrant side) aligned with each fire hydrant location per City requirements.

Removal and disposal of existing sign posts and installation of new 2” Telespar post shall be installed as shown on project plans. Locations of all sign posts shall be approved by the engineer prior to installation. Post installed in concrete areas for traffic signs only shall utilize a surface-mounted break-away type sleeve to the satisfaction of the engineer. Post shall be installed on FHWA approved breakaway type sleeve for post and then install concrete completely to the satisfaction of the engineer. The Contractor shall remove existing posts and install new posts where shown on plans and as directed by the engineer. Payment for installation of 2” Telespar traffic posts with FHWA approved breakaway posts shall be included in the lump sum price bid for **TRAFFIC SIGNING, STRIPING, PAVEMENT MARKERS AND PAVEMENT MARKINGS (BID ITEM 5)** and shall include all labor, tools, equipment, materials and incidentals necessary to complete the work, including removal and disposal of existing posts where shown on plans and installation of new posts complete in place; no additional compensation shall be allowed therefor.

Full compensation for conforming to the requirements in this article TRAFFIC SIGNING, STRIPING, PAVEMENT MARKERS AND PAVEMENT MARKINGS (BID ITEM 5) shall be considered as included in the contract bid price per Lump Sum (LS), and shall include all labor, tools, materials and appurtenances necessary to complete the work and no additional compensation will be allowed therefor.

ARTICLE 12.06: UNCLASSIFIED EXCAVATION AND DISPOSAL: This bid item shall include all labor, tools, materials and appurtenances necessary to complete the work necessary as part of this article which shall include, but not be limited to, sawcut, remove existing roadway structural asphalt concrete pavement, base aggregate, landscaping improvements and/or subgrade soils as necessary to prepare for placement of AC pavement per plans.

The removal of pumping soil, if encountered, shall also be included in unclassified excavation. Limits of additional removals due to pumping soil shall be specified by the Engineer.

Excavation, grading and backfill shall be done in conformance with the applicable portion of Section 300 “Earthwork” of the Standard Specifications and shall include any necessary excavation, and/or fill within the right-of-way, including imported material grading of area to finish subgrade ready for improvements, as shown on the plans or as directed by the Engineer.

The Contractor shall comply with Section 300-2.6, “Surplus Material”, and shall furnish written consent from the owner of the property where it is intended to dispose of the surplus material.

When the exposed subgrade within 1.0 foot of the grading plane has a relative compaction of less than ninety percent (90%), the subgrade shall be scarified and recompacted in accordance with the provisions of the Standard Specifications and the relative compaction shall not be less than ninety percent (90%). All aggregate base or crushed miscellaneous base material shall be compacted to 95 percent (95%) of relative maximum density. Tests for the compliance may be made by a

representative of the CITY, at the expense of the CITY, using Test Method No. California 231. In the event the initial test fails, additional tests shall be made at the Contractor's expense.

Backfill material and placement shall conform to the applicable portions of Section 300 of the Standard Specifications.

The bid item may be increased or reduced at the discretion of the City. The provisions of Section 2-7.1 of the Greenbook governing increases or decreases in quantity of more than 25% shall not apply to this item. Unit prices shall continue to apply to the increased or decreased quantities for more and less than twenty-five percent (25%).

Compensation for this bid item shall be measured and quantified through volumetric measurements of the actual excavated volumetric dimensions of asphalt full depth removals. Contractor shall measure and confirm all volume measurements of excavation with inspector for approval of payment.

Full compensation for conforming to the requirements in this article UNCLASSIFIED EXCAVATION AND DISPOSAL (BID ITEM 6) shall be considered as included in the contract bid price per Cubic Yard (CY), and shall include all labor, tools, materials and appurtenances necessary to complete the work, including costs for trucking and disposing of material, and no additional compensation will be allowed therefor.

ARTICLE 12.07: COLD MILL EXISTING AC PAVEMENT TO 2" DEPTH This bid item shall include all labor, tools, materials and appurtenances necessary to cold mill 2" depth of asphalt concrete pavement. Cold milling shall conform to Section 404 of the Standard Specifications and as indicated in these Special Provisions.

Existing asphalt concrete shall be milled at the locations and to the dimensions shown on the design plans and in accordance with these Special Provisions. The milling of asphalt concrete pavement shall be performed by cold milling. The cold milling machine shall have a cutter head at least 30 inches wide and shall be operated so as not to produce fumes or smoke. The depth, width and shape of the cut shall be as indicated on the typical cross sections or as directed by the Engineer. The final cut shall result in a uniform surface conforming to typical cross sections. The outside lines of the milled area shall be neat and uniform. The road surfacing to remain in place and other improvements in the public right-of-way or on private property shall not be damaged in any way. The Contractor shall use extreme caution when cold milling adjacent to the existing gutters, so as not to cause chipping and breakage of the concrete. The Contractor shall be responsible for the replacement of any and all concrete improvements damaged during the milling process.

The Contractor shall be responsible to locate and mark all facilities such as sewer manhole covers, telephone manhole covers, water valve covers, and catch basin covers, which, if struck, could damage the cold milling cutting drum and/or cutting teeth. The Contractor shall thoroughly inspect the work site in advance of the cold milling operation to minimize the risk of striking any unseen under surface object(s) and shall include in the price(s) bid for edge milling removal work an additional amount sufficient to cover the cost of damage related down time and the cost of repair of damage to said cold milling cutting drum and/or cutting teeth.

The material milled from the roadway surface, including material deposited in existing gutters or on the adjacent traveled way, shall be immediately removed from the site of the work and disposed of outside the road right-of-way. The removal crew shall follow within fifty (50) feet of the miller unless otherwise directed by the Engineer.

Residue from grinding shall not be permitted to flow or travel into gutters, onto adjacent street surfaces or parkways. All residue shall be immediately and completely removed by sweeping and properly disposed of. No washing of residue into drainage structures will be allowed. Cold milled materials shall become the property of the Contractor.

Both the perpendicular and parallel temporary taper transition may be achieved by over milling outside of the specified full depth mill limits or by using a full depth mill inside the specified full depth mill limits followed by a temporary asphalt concrete ramp. **The temporary asphalt concrete ramp must be removed prior to the actual asphalt concrete base course placement.** Adherence to all of the preceding temporary pavement surface maintenance requirements shall be absorbed into the unit costs for the various mills. Temporary ramping, where required by the Engineer for traffic control or other purposes, shall be considered included in this article and no additional compensation will be allowed.

In areas where new asphalt pavement will join existing asphalt pavement, the Contractor shall sawcut edges to ensure a clean joint to existing asphalt pavement and as shown on the plans.

Milled asphalt concrete pavement will be measured by the square foot. The quantity to be paid for will be the actual area of surface milled irrespective of the number of passes required.

The bid item may be increased or reduced at the discretion of the City. The provisions of Section 2-7.1 of the Greenbook governing increases or decreases in quantity of more than 25% shall not apply to this item. Unit prices shall continue to apply to the increased or decreased quantities for more and less than twenty-five percent (25%).

Full compensation for conforming to the requirements in this article COLD MILL EXISTING AC PAVEMENT TO 2" DEPTH (BID ITEM 7) shall be considered as included in the contract bid price per SQUARE FOOT (SF), and shall include all labor, tools, materials and appurtenances necessary to complete the work, including costs for trucking and disposing of material, and no additional compensation will be allowed therefor.

ARTICLE 12.08 CMB (CRUSHED MISCELLANEOUS BASE) AS NEEDED. The Contractor shall remove existing pavement, aggregate base, and subbase soils as needed to prepare for placement of AC PAVEMENT OR PCC. Installation of CMB may be required depending on the existing conditions of the subgrade or if pumping occurs after roadway excavation, local digouts and PCC removal. **CMB shall only be used as needed for unsuitable soil conditions and shall require prior approval from engineer before installation.**

The excavation and disposal of existing base material, native soil, subgrade in preparation for placement and compaction of CMB is considered inclusive of Bid Item 8. The removal of pumping soil, if encountered, shall also be included in the bid price. Limits of additional removals due to pumping soil shall be specified by the Engineer.

The Contractor may excavate 4 - 6 inch depth as directed by the Engineer, regrade and compact the subgrade materials, place and compact CMB material. The excavation depth may be increased beyond 6 inches at the direction of the Engineer and additional excavation, labor, materials, tools and all appurtenance needed to satisfy the task is inclusive of Bid Item 8. The unit price shall include all excavation, including costs for trucking of material, proper disposal including trucking, compaction of base and subbase, regrading, labor, tools, equipment, materials, and incidentals required to complete the work and no additional compensation will be allowed.

CMB shall be per Section 200-2.4 of Greenbook and Table 200-2.4.2, fine gradation.

When the exposed subgrade within 1.0 foot of the grading plane has a relative compaction of less than ninety percent (90%), the subgrade shall be scarified and recompacted in accordance with the provisions of the Standard Specifications and the relative compaction shall not be less than ninety percent (90%). All aggregate base or crushed miscellaneous base material shall be compacted to 95 percent (95%) of relative maximum density. Tests for the compliance may be made by a representative of the CITY, at the expense of the CITY, using Test Method No. California 231. In the event the initial test fails, additional tests shall be made at the Contractor's expense.

Due to the low R value and high moisture content of subgrade soils present, construction equipment and traffic shall minimize travel on subgrade soils. The contractor shall remove existing materials to grade with milling equipment of sufficient size to remove materials in one pass, excavator working from existing pavement surfaces, or a similar method.

Asphalt pavement material shall be placed with a paving machine having tracks, or other equipment capable of placing asphalt concrete while minimizing loads on the subgrade soil or base course.

Construction equipment shall minimize repeated heavy traffic loadings, such as dump trucks, traveling repeatedly over the same pavement areas, so as to minimize the possibility of subgrade "pumping". Subgrade and pavement failures caused by repeated heavy load traffic shall be repaired at the expense of the Contractor.

The Contractor shall replace and repair any irrigation system damaged by his operation in all locations. In some locations, there may be tree roots that need to be removed for proper construction of the improvements. In these cases, the Contractor, at his own expenses, shall cut, remove, and properly dispose the roots per Engineer instructions and per all applicable laws, rules and regulations. All work necessary to remove and properly dispose of all removed material shall be at no extra cost to the CITY.

Payment for root pruning within the limits of the sidewalk shall be included in the contract bid price.

These pruning guidelines shall be followed by all persons or firms repairing or replacing damaged street, curbs, sidewalks, driveways, or access ramps where the damage is attributable to the roots of the trees growing in the public right-of-way. At least two (2) days prior to any digging or excavating, DigAlert and the Parks Department at 562-383-4170, must be notified.

The Contractor shall remove the concrete at all tree root locations and notify the Parks Department forty-eight (48) hours in advance prior to performing root pruning or selective root removal.

One of the following methods or a combination of methods shall be used when pruning or root removal of tree roots:

Whenever possible, root pruning should only be performed on one side of a tree at a time, meaning on the sidewalk side or street side, but not on both, unless specifically authorized by the City Arborist.

- a. Root Pruning: The actual pruning of roots should be done using a trenching machine, which operates in a vertical motion only, with a root pruning attachment or some comparable piece of equipment, which can safely cut a narrow trench four (4) to six (6) inches wide.
- b. Selective Root Removal: Root larger than three (3) inches in diameter shall be horizontally trimmed or selectively removed. The utilization of a chain saw or other sawing tool shall be employed during this procedure. This procedure shall be overseen by the City Arborist.

All tree activity shall be conducted in a manner specified by ANSI Z133.1 – 2006 Safety Requirements & ANSI A300 (Part 1)-2001 Standard Practices (Pruning).

If the report from the City Arborist recommends the tree be removed because necessary root pruning would be detrimental to the structural integrity of the tree, the Contractor will coordinate with the CITY for removal by CITY resources.

The bid item may be increased or reduced at the discretion of the City. The provisions of Section 2-7.1 of the Greenbook governing increases or decreases in quantity of more than 25% shall not apply to this item. Unit prices shall continue to apply to the increased or decreased quantities for more and less than twenty-five percent (25%).

Full compensation for complying with the work contained in this section shall be included in the contract TON (TN) price bid for CMB (CRUSHED MISCELLANOUS BASE) AS NEEDED (BID ITEM 8). The unit price shall include all excavation, including costs for trucking of material and proper disposal including trucking, compaction, regrading, labor, tools, equipment, materials, and incidentals required to complete the work. No additional compensation will be allowed.

ARTICLE 12.09 INSTALL 4" THICK ASPHALT CONCRETE BASE COURSE (B PG 64-10):
The Contractor shall place asphalt concrete pavement as required by these specifications and

drawings. Payment for all asphalt concrete shall be included in this pay item. All full depth joints shall be neatly sawcut.

Asphalt concrete shall be Hot Mix Asphalt Type B PG 64-10 and shall be placed in one or two lifts.

Paving asphalt used for asphalt concrete shall be performance grade PG 64-10. Composition and Grading shall be per Section 203-6.3 of the Standard Specifications (latest edition). The Contractor shall submit a copy of the asphalt concrete mix design to the City or its designated laboratory a minimum of two weeks prior to the start of the construction.

Apply SS-1H tack coat at a rate not to exceed one-tenth (1/10) gallon per square yard uniformly in one coat on all vertical joints of AC patching and P.C.C. surfaces and edges against which AC is to be placed. Diesel fuel shall not be used for cleaning purposes within the limits of this project.

The Contractor shall utilize a paving machine equipped with an automatic adjusting screed, which is actuated by a 30-foot “ski”, for the entire AC overlay.

AC shall be thoroughly compacted by rolling. The number of rollers necessary will be established in accordance with Section 302-5.6.1 of the Greenbook Specifications. All compacted AC shall have a relative compaction of not less than 95 percent in accordance with Section 302-5.6.2 of the Greenbook Specifications.

Rolling along a joint shall be such that the widest part of the roller is on the hot side of the joint. Joint lines between successive runs shall be within 5 inches of lane lines or a minimum of 12 feet outside of the outer most lane line.

Due to the low R value and high moisture content of subgrade soils present, construction equipment and traffic shall minimize travel on subgrade soils. The contractor shall remove existing materials to grade with milling equipment of sufficient size to remove materials in one pass, excavator working from existing pavement surfaces, or a similar method.

Asphalt pavement material shall be placed with a paving machine having tracks, or other equipment capable of placing asphalt concrete while minimizing loads on the subgrade soil or base course.

Construction equipment shall minimize repeated heavy traffic loadings, such as dump trucks, traveling repeatedly over the same pavement areas, so as to minimize the possibility of subgrade “pumping”. Subgrade and pavement failures caused by repeated heavy load traffic shall be repaired at the expense of the Contractor.

The final lift of pavement shall be placed with conventional spreader equipment. However, the Contractor shall avoid unnecessary and repeated heavy traffic loadings on the same pavement areas.

The Contractor is warned that some locations may have shallow utility services in the shoulder areas. Contractor shall exercise due caution to protect utilities in these areas.

All Full depth reconstruction shall be completed before the weekend. Paving shall be completed within two days of cold-milling operation. No pavement shall be left uneven over the weekend and AC reconstruction shall be completed before the weekend.

Payment for root pruning within the limits of the asphalt work shall be included in the contract bid price.

Contractor shall plan their work in a manner that will provide full access at all times to residents of Susanglen Circle and Villageglen Lane. These neighborhoods (located on east side of Monte Vista Street) only have access via Monte Vista Street.

These pruning guidelines shall be followed by all persons or firms repairing or replacing damaged street, curbs, sidewalks, driveways, or access ramps where the damage is attributable to the roots of the trees growing in the public right-of-way. At least two (2) days prior to any digging or excavating, DigAlert and the Parks Department at 562-383-4170, must be notified.

The Contractor shall remove the concrete at all tree root locations and notify the Parks Department forty-eight (48) hours in advance prior to performing root pruning or selective root removal.

One of the following methods or a combination of methods shall be used when pruning or root removal of tree roots:

Whenever possible, root pruning should only be performed on one side of a tree at a time, meaning on the sidewalk side or street side, but not on both, unless specifically authorized by the City Arborist.

- a. Root Pruning: The actual pruning of roots should be done using a trenching machine, which operates in a vertical motion only, with a root pruning attachment or some comparable piece of equipment, which can safely cut a narrow trench four (4) to six (6) inches wide.
- b. Selective Root Removal: Root larger than three (3) inches in diameter shall be horizontally trimmed or selectively removed. The utilization of a chain saw or other sawing tool shall be employed during this procedure. This procedure shall be overseen by the City Arborist.

All tree activity shall be conducted in a manner specified by ANSI Z133.1 – 2006 Safety Requirements & ANSI A300 (Part 1)-2001 Standard Practices (Pruning).

If the report from the City Arborist recommends the tree be removed because necessary root pruning would be detrimental to the structural integrity of the tree, the Contractor will coordinate with the CITY for removal by CITY resources.

Full compensation for complying with the work contained in this section shall be included in the contract TON (TN) price bid for INSTALL 4" THICK ASPHALT CONCRETE BASE COURSE (B PG 64-10) (BID ITEM 9). The unit price shall include all surface preparation, tack coat, rock

dust blotter, labor, tools, equipment, materials, including costs for trucking of material, and incidentals required to complete the work. No additional compensation will be allowed.

ARTICLE 12.10: INSTALL 2” THICK ASPHALT RUBBER HOT MIX OVERLAY (ARHM-GG-C PG 64-16)

This item in the bid price per Tons includes all labor, tools, materials and appurtenances necessary to lay the Rubberized Asphalt as follows:

Asphalt concrete surface course shall be Asphalt Rubber Hot Mix, Type ARHM-GG-C, wet process, as specified in Section 203-11 and 302-9 of the Standard Specifications (last edition), per Typical Sections as shown on the plans, and shall conform to the following:

Paving asphalt used for asphalt-rubber shall be performance grade PG 64-16. Composition and Grading shall be per Section 203-11.3 of the Standard Specifications (latest edition). The Contractor shall submit a copy of the asphalt concrete mix design to the City or its designated laboratory a minimum of two weeks prior to the start of the construction.

The Contractor shall place the ARHM no later than 48 hours after the commencement of all edge grinding operations during any stage of the work for this project. No streets will be left grinded over the weekend (Saturday through Sunday) and Holidays. The contractor shall coordinate their work accordingly.

Apply SS-1H tack coat at a rate not to exceed one-tenth (1/10) gallon per square yard uniformly in one coat on all vertical joints of AC patching and P.C.C. surfaces and edges against which ARHM is to be placed. Diesel fuel shall not be used for cleaning purposes within the limits of this project.

All surfaces to be overlaid shall be cleaned by the use of a broom and a vacuum sweeper. The overlaid surface shall be free of water, dust, or foreign material before tack is applied. All raised pavement markers shall be removed prior to the placement of any ARHM concrete overlay. Removal of all AC slurry seal residue from gutter lip should be completed prior to paving.

The Contractor shall utilize a paving machine equipped with an automatic adjusting screed, which is actuated by a 30-foot “ski”, for the entire ARHM-GG overlay.

ARHM-GG shall be thoroughly compacted by rolling. The number of rollers necessary will be established in accordance with Section 302-5.6.1 of the Greenbook Specifications. All compacted ARHM-GG shall have a relative compaction of not less than 95 percent in accordance with Section 302-5.6.2 of the Greenbook Specifications.

Rolling along a joint shall be such that the widest part of the roller is on the hot side of the joint. Joint lines between successive runs shall be within 5 inches of lane lines or a minimum of 12 feet outside of the outer most lane line.

The contractor shall only have horizontal cold joints. Contractor shall submit a paving schedule that indicates all hot joints and cold joints that are proposed along Monte Vista Street to the City. The City will review and approve all proposed hot joint and cold joint locations. Any additional mobilization/demobilization and all incidentals required to satisfy approved hot/cold joint locations shall be included in the contract unit price bid per ton for BID ITEM 10 and no additional compensation will be allowed.

The Contractor shall provide for adequate quality control measures to ensure that delivery of asphalt rubber shall be neither too slow nor too fast to prevent stopping of the paving operation and/or cooling of the asphalt rubber material. Material delivery scheduling and handling is critical to provide for optimum compaction opportunity and maximize ride quality performance.

Rock dust blotter material shall be required immediately after the completions of the “finish rolling” and prior to opening to traffic to prevent bleeding and tracking of the asphalt rubber material.

Rock dust blotter shall be per Section 200-1.2 of the Standard Specifications and shall be uniformly applied using a mechanical spreader, which distributes uniformly at a rate of approximately three pounds per square yard. Compaction rollers shall not be allowed on the rock dust covered pavement surfaces. All excess rock dust blotter shall be removed from the street at the end of each workday.

The bid item may be increased or reduced at the discretion of the City. The provisions of Section 2-7.1 of the Greenbook governing increases or decreases in quantity of more than 25% shall not apply to this item. Unit prices shall continue to apply to the increased or decreased quantities for more and less than twenty-five percent (25%).

Full compensation for conforming to the requirement in this article INSTALL 2” THICK ASPHALT RUBBER HOT MIX OVERLAY (ARHM-GG-C PG 64-16) (BID ITEM 10), shall be included in the contract unit price bid per ton (TON), based upon **certified weigh master tickets**. The unit price shall include all surface preparation, tack coat, rock dust blotter, labor, tools, equipment, materials, including costs for trucking of material, and incidentals required to complete the work. No additional compensation will be allowed.

ARTICLE 12.11: REMOVE EXISTING, GRADE AND INSTALL 4” THICK ASPHALT CONCRETE PAVEMENT (C2 PG 64-10)

This item in the bid price per Tons includes all labor, tools, materials and appurtenances necessary to lay the Asphalt as follows:

Asphalt concrete surface course shall be Asphalt Concrete Hot Mix, Type C2 PG 64-10, wet process, as specified in Section 203-6 and 302-5 of the Standard Specifications (last edition), per Typical Sections as shown on the plans, and shall conform to the following:

Paving asphalt used for asphalt concrete shall be performance grade PG 64-10. Composition and Grading shall be per Section 203-6.3 of the Standard Specifications (latest edition). The

Contractor shall submit a copy of the asphalt concrete mix design to the City or its designated laboratory a minimum of two weeks prior to the start of the construction.

The Contractor shall place the AC no later than 48 hours after the commencement of all grinding operations during any stage of the work for this project. No streets will be left grinded over the weekend (Saturday through Sunday) and Holidays. The contractor shall coordinate their work accordingly.

Apply SS-1H tack coat at a rate not to exceed one-tenth (1/10) gallon per square yard uniformly in one coat on all vertical joints of AC patching and P.C.C. surfaces and edges against which AC is to be placed. Diesel fuel shall not be used for cleaning purposes within the limits of this project.

All surfaces to be overlaid shall be cleaned by the use of a broom and a vacuum sweeper. The overlaid surface shall be free of water, dust, or foreign material before tack is applied. All raised pavement markers shall be removed prior to the placement of any AC concrete overlay. Removal of all AC slurry seal residue from gutter lip should be completed prior to paving.

The Contractor shall utilize a paving machine equipped with an automatic adjusting screed.

AC shall be thoroughly compacted by rolling. The number of rollers necessary will be established in accordance with Section 302-5.6.1 of the Greenbook Specifications. All compacted AC shall have a relative compaction of not less than 95 percent in accordance with Section 302-5.6.2 of the Greenbook Specifications.

Rolling along a joint shall be such that the widest part of the roller is on the hot side of the joint.

The contractor shall only have horizontal cold joints. Contractor shall submit a paving schedule that indicates all hot joints and cold joints that are proposed. The City will review and approve all proposed hot joint and cold joint locations. Any additional mobilization/demobilization and all incidentals required to satisfy approved hot/cold joint locations shall be included in the contract unit price bid per ton for BID ITEM 11 and no additional compensation will be allowed.

The Contractor shall provide for adequate quality control measures to ensure that delivery of asphalt shall be neither too slow nor too fast to prevent stopping of the paving operation and/or cooling of the asphalt material. Material delivery scheduling and handling is critical to provide for optimum compaction opportunity and maximize ride quality performance.

Rock dust blotter material shall be required immediately after the completions of the “finish rolling” and prior to opening to traffic to prevent bleeding and tracking of the asphalt rubber material.

Rock dust blotter shall be per Section 200-1.2 of the Standard Specifications and shall be uniformly applied using a mechanical spreader, which distributes uniformly at a rate of approximately three pounds per square yard. Compaction rollers shall not be allowed on the rock dust covered

pavement surfaces. All excess rock dust blotter shall be removed from the street at the end of each workday.

Removal of existing asphalt, subgrade, and preparation of native soil shall be in conformance with Bid Item 6 – Unclassified Excavation and Disposal. Compensation for excavation and disposal shall be from Bid Item 6 – Unclassified Excavation and Disposal.

The bid item may be increased or reduced at the discretion of the City. The provisions of Section 2-7.1 of the Greenbook governing increases or decreases in quantity of more than 25% shall not apply to this item. Unit prices shall continue to apply to the increased or decreased quantities for more and less than twenty-five percent (25%).

Full compensation for conforming to the requirement in this article REMOVE EXISTING, GRADE AND INSTALL 4" THICK ASPHALT CONCRETE PAVEMENT (C2 PG 64-10) (BID ITEM 11), shall be included in the contract unit price bid per ton (TON), based upon **certified weigh master tickets**. The unit price shall include all surface preparation, tack coat, rock dust blotter, labor, tools, equipment, materials, including costs for trucking of material, and incidentals required to complete the work. No additional compensation will be allowed.

ARTICLE 12.12: SAWCUT AND REMOVE EXISTING SIDEWALK. CONSTRUCT NEW 4" THICK PCC SIDEWALK OVER COMPACTED NATIVE SOIL: This bid item shall include all labor, tools, materials and appurtenances necessary to complete the work necessary to remove existing and construct new 4" thick Portland Cement Concrete (PCC) sidewalk over compacted native soil complete in place. The Contractor shall saw-cut, excavate and remove existing in-place materials as necessary and properly dispose of material, subgrade and concrete for new construction; compact subgrade; and construct new 4" thick PCC sidewalk over compacted native soil as directed and as shown per detail drawings. New sidewalk finish shall match existing. Limits of construction shall be verified, measured and marked in the field by the Engineer prior to removing existing improvements. Removal and disposal of existing pavement and base/subgrade for construction of new 4" PCC sidewalk over compacted native soil shall be included in the contract bid price. 4" PCC sidewalk shall be built in accordance with City of La Habra Standard Detail R-14 without sand.

Portland cement concrete material shall be Portland Cement Concrete of Type 520-C-2500.

If PCC sidewalk joins Asphalt Concrete parking lot, contractor shall provide 1' AC Slot Patch, 8" depth adjoining back of sidewalk panel. Filling crack with PCC indicated as construction note 13 will be measured and bid through bid item 12. Compensation for this item is considered included in this bid item.

Integral retaining curbs with a minimum 6-inch height and 6-inch width adjoining any sidewalk panel as noted on the plans is considered part of Bid Item 19. The Contractor shall increase height of retaining curb as needed to match existing landscape grades.

If native soil is determined to be unsuitable for construction of new PCC sidewalk, with the approval and under the direction of the engineer/inspector the contractor may excavate 4" of native

soil, compact sub-grade to 90%, place and compact 4" Crushed Miscellaneous Base (CMB) prior to construction of new PCC sidewalk. Removal and disposal of native soil and placement/compaction of CMB will be paid for by CMB AS NEEDED (BID ITEM 8) and shall include all excavation, including costs for trucking of material and proper disposal, compaction, regrading, labor, tools, equipment, materials, and incidentals required to complete the work in compliance with Bid Item 8. No additional compensation will be allowed.

The Contractor shall re-establish any survey monument that is disturbed, including at the property lines, with no extra cost to CITY to the satisfaction of the Engineer. This Item will be paid under the "Construction Staking and Monument Perpetuation" bid item.

Sidewalks shall meet all ADA requirements and shall not create impediments to access. Sidewalk features, per standard plan, shall include:

Cross-slope not exceeding 1.5% slope
Running slope not exceeding 4.5% slope

The Contractor shall replace and repair any irrigation system damaged by his operation in all locations. In some locations, there may be tree roots that need to be removed for proper construction of the improvements. In these cases, the Contractor, at his own expenses, shall cut, remove, and properly dispose the roots per Engineer instructions and per all applicable laws, rules and regulations. All work necessary to remove and properly dispose of all removed material shall be at no extra cost to the CITY.

Payment for root pruning within the limits of the sidewalk shall be included in the contract bid price.

These pruning guidelines shall be followed by all persons or firms repairing or replacing damaged street, curbs, sidewalks, driveways, or access ramps where the damage is attributable to the roots of the trees growing in the public right-of-way. At least two (2) days prior to any digging or excavating, DigAlert and the Parks Department at 562-383-4170, must be notified.

The Contractor shall remove the concrete at all tree root locations and notify the Parks Department forty-eight (48) hours in advance prior to performing root pruning or selective root removal.

One of the following methods or a combination of methods shall be used when pruning or root removal of tree roots:

Whenever possible, root pruning should only be performed on one side of a tree at a time, meaning on the sidewalk side or street side, but not on both, unless specifically authorized by the City Arborist.

- c. Root Pruning: The actual pruning of roots should be done using a trenching machine, which operates in a vertical motion only, with a root pruning attachment or some comparable piece of equipment, which can safely cut a narrow trench four (4) to six (6) inches wide.

- d. Selective Root Removal: Root larger than three (3) inches in diameter shall be horizontally trimmed or selectively removed. The utilization of a chain saw or other sawing tool shall be employed during this procedure. This procedure shall be overseen by the City Arborist.

All tree activity shall be conducted in a manner specified by ANSI Z133.1 – 2006 Safety Requirements & ANSI A300 (Part 1)-2001 Standard Practices (Pruning).

If the report from the City Arborist recommends the tree be removed because necessary root pruning would be detrimental to the structural integrity of the tree, the Contractor will coordinate with the CITY for removal by CITY resources.

The bid item may be increased or reduced at the discretion of the City. The provisions of Section 2-7.1 of the Greenbook governing increases or decreases in quantity of more than 25% shall not apply to this item. Unit prices shall continue to apply to the increased or decreased quantities for more and less than twenty-five percent (25%).

No open excavations will be allowed over a weekend or holiday. The Contractor shall schedule work to accommodate this requirement. All concrete must be in place and forms removed prior to weekends and holidays.

Full compensation for conforming to the requirements in this article SAWCUT AND REMOVE EXISTING SIDEWALK. CONSTRUCT NEW 4" THICK PCC SIDEWALK OVER COMPACTED NATIVE SOIL (BID ITEM 12) shall be considered as included in the contract bid price per Square Foot (SF), and shall include all labor, tools, materials and appurtenances necessary to complete the work, including costs for trucking and disposing of material, and no additional compensation will be allowed therefor.

ARTICLE 12.13: SAWCUT AND REMOVE EXISTING CROSS-GUTTER AND SPANDREL. CONSTRUCT NEW 8" PCC CROSS-GUTTER AND SPANDREL PER LA HABRA STD. DETAIL R-6 OVER 6" CMB. 1' WIDE AC SLOT PATCH, TYPE C2 PG 64 - 10. This bid item shall include all labor, tools, materials and appurtenances necessary to complete the work necessary to saw cut and remove existing cross-gutter and spandrel and construct new 8" PCC cross-gutter and 8" spandrel per La Habra Std. Detail R-6 without dowels over 6" CMB. 1' wide AC slot patch, complete in place. The Contractor shall saw-cut, excavate and remove existing in-place materials as necessary and properly dispose of material, subgrade and concrete for new construction; compact subgrade; place and compact base; and construct new 8" PCC cross gutter and 8" spandrel as directed and as shown per detail drawings. New cross gutter shall join existing flow lines. The Contractor shall construct an asphalt concrete slot twelve inches wide with length that matches the length of the new cross gutter. New cross gutter finish shall match existing finish and flowline. Removal of existing pavement and base/subgrade, and the installation of the AC slot patch shall be included in the contract bid price. Limits of construction shall be verified, measured and marked in the field by the Engineer prior to removing existing improvements. Ribbon gutter located in Alley on Sheet 8, construction note 32, is considered inclusive of this bid item. Alley Ribbon gutter shall match existing and be constructed per Greenbook, standard plan 122-3, 8"

thick PCC over 6" CMB without dowels and shall include all labor, tools, materials and appurtenances necessary to complete the work including costs for trucking and disposing of material and no additional compensation will be allowed therefor.

Portland cement concrete material shall be Portland Cement Concrete of Type 520-C-2500. Slot Patch should be Type C2 PG 64-10, 1 foot wide and 8 inch depth. CMB shall be per Section 200-2.4 of Greenbook and Table 200-2.4.2, fine gradation:

Work shall be phased and constructed so that at the end of each work day, excavated trenches will be covered flush to grade by steel plates, opened to traffic, and parking restored.

No open excavations will be allowed over a weekend or holiday. The Contractor shall schedule work to accommodate this requirement. All concrete must be in place and forms removed prior to weekends and holidays.

The bid item may be increased or reduced at the discretion of the City. The provisions of Section 2-7.1 of the Greenbook governing increases or decreases in quantity of more than 25% shall not apply to this item. Unit prices shall continue to apply to the increased or decreased quantities for more and less than twenty-five percent (25%).

Full compensation for conforming to the requirements in this article SAW CUT AND REMOVE EXISTING CROSS-GUTTER AND SPANDREL. CONSTRUCT NEW 8" PCC CROSS-GUTTER AND SPANDREL PER LA HABRA STD. DETAIL R-6 OVER 6" CMB. 1' WIDE AC SLOT PATCH, TYPE C2 PG 64 - 10. (BID ITEM 13) shall be considered as included in the contract bid price per Square Foot (SF), and shall include all labor, tools, materials and appurtenances necessary to complete the work including costs for trucking and disposing of material and no additional compensation will be allowed therefor.

ARTICLE 12.14: SAWCUT AND REMOVE EXISTING DRIVEWAY APPROACH. CONSTRUCT NEW 6" PCC DRIVEWAY APPROACH PER SPPWC 110-2.: This bid item shall include all labor, tools, materials and appurtenances necessary to complete the work necessary to sawcut and remove existing driveway approach and construct new 6" PCC driveway approach per SPPWC 110-2. The Contractor shall saw-cut, excavate and remove existing in-place materials as necessary and properly dispose of material, subgrade and concrete for new construction; compact subgrade; and construct new 6" driveway approach as directed and as shown per detail drawings. New driveway approach shall join existing flow lines. New driveway approach finish shall match existing finish and flowline. **Curb and gutter shall not be poured monolithic with the driveway apron.** Limits of construction shall be verified, measured and marked in the field by the Engineer prior to removing existing improvements.

If the right of way is not wide enough to allow for a SPPWC 110-2, the driveway shall become the path of travel which shall be ADA complaint and constructed per the plan and under the direction of the engineer. The driveway path of travel shall have the following: Cross-slope not exceeding 1.5% slope, Running Slope not exceeding 4.5% slope. Contractor shall excavate as needed to achieve said slopes and disposal of material is considered included in this bid item. Compensation

for this bid item will be per the bid price for bid item 14 and shall include all labor, tools, materials and appurtenances necessary to complete the work necessary.

Sidewalks located behind driveway approaches shall be included in BID ITEM 14; PCC sidewalk thickness shall be 6" minimum over compacted native soil for all sidewalks behind driveway approaches. Measurement and payment for 6" sidewalk will be from the unit price bid of BID ITEM 14, including include all excavation, including costs for trucking of material and proper disposal, compaction of base and subbase, regrading, labor, tools, equipment, materials, and incidentals required to complete the work and no additional compensation will be allowed.

Sidewalks shall meet all ADA requirements and shall not create impediments to access. Sidewalks features, per standard plan, shall include:

- Cross-slope not exceeding 1.5% slope
- Running slope not exceeding 4.5% slope

If native soil is determined to be unsuitable for construction of new 6" driveway, with the approval and under the direction of the engineer/inspector the contractor may excavate 4" of native soil, compact sub-grade to 90%, place and compact 4" Crushed Miscellaneous Base (CMB) prior to construction of new 6" driveway. Removal and disposal of native soil and placement/compaction of CMB will be paid for by CMB AS NEEDED (BID ITEM 8) and shall include all excavation, including costs for trucking of material and proper disposal, compaction, regrading, labor, tools, equipment, materials, and incidentals required to complete the work in compliance with Bid Item 8. No additional compensation will be allowed.

Portland cement concrete material shall be Portland Cement Concrete of Type 520-C-2500. Slot Patch should be Type C2 PG 64-10, 1 foot wide and 8 inch depth.

The Contractor shall replace and repair any irrigation system damaged by his operation in all locations. In some locations, there may be tree roots that need to be removed for proper construction of the improvements. In these cases, the Contractor, at his own expenses, shall cut, remove, and properly dispose the roots per Engineer instructions and per all applicable laws, rules and regulations. All work necessary to remove and properly dispose of all removed material shall be at no extra cost to the CITY.

Payment for root pruning within the limits of the driveway apron shall be included in the contract bid price.

These pruning guidelines shall be followed by all persons or firms repairing or replacing damaged street, curbs, sidewalks, driveways, or access ramps where the damage is attributable to the roots of the trees growing in the public right-of-way. At least two (2) days prior to any digging or excavating, DigAlert and the Parks Department at 562-383-4170, must be notified.

The Contractor shall remove the concrete at all tree root locations and notify the Parks Department forty-eight (48) hours in advance prior to performing root pruning or selective root removal.

One of the following methods or a combination of methods shall be used when pruning or root removal of tree roots:

Whenever possible, root pruning should only be performed on one side of a tree at a time, meaning on the sidewalk side or street side, but not on both, unless specifically authorized by the City Arborist.

- a. Root Pruning: The actual pruning of roots should be done using a trenching machine, which operates in a vertical motion only, with a root pruning attachment or some comparable piece of equipment, which can safely cut a narrow trench four (4) to six (6) inches wide.
- b. Selective Root Removal: Root larger than three (3) inches in diameter shall be horizontally trimmed or selectively removed. The utilization of a chain saw or other sawing tool shall be employed during this procedure. This procedure shall be overseen by the City Arborist.

All tree activity shall be conducted in a manner specified by ANSI Z133.1 – 2006 Safety Requirements & ANSI A300 (Part 1)-2001 Standard Practices (Pruning).

If the report from the City Arborist recommends the tree be removed because necessary root pruning would be detrimental to the structural integrity of the tree, the Contractor will coordinate with the CITY for removal by CITY resources.

The Contractor shall paint the address of any house that is on a replaced curb with no extra cost to CITY to the satisfaction of the Engineer.

The bid item may be increased or reduced at the discretion of the City. The provisions of Section 2-7.1 of the Greenbook governing increases or decreases in quantity of more than 25% shall not apply to this item. Unit prices shall continue to apply to the increased or decreased quantities for more and less than twenty-five percent (25%).

No open excavations will be allowed over a weekend or holiday. The Contractor shall schedule work to accommodate this requirement. All concrete must be in place and forms removed prior to weekends and holidays.

Full compensation for conforming to the requirements in this article SAWCUT AND REMOVE EXISTING DRIVEWAY APPROACH. CONSTRUCT NEW 6" PCC DRIVEWAY APPROACH PER SPPWC 110-2. (BID ITEM 14) shall be considered as included in the contract bid price per Square Foot (SF), and shall include all labor, tools, materials and appurtenances necessary to complete the work including costs for trucking and disposing of material and no additional compensation will be allowed therefor.

ARTICLE 12.15: SAWCUT AND REMOVE EXISTING ALLEY APPROACH. CONSTRUCT NEW 8" PCC ALLEY APPROACH PER SPPWC 130-3.: This bid item shall include all labor, tools, materials and appurtenances necessary to complete the work necessary to sawcut and remove existing alley approach and construct new 8" PCC alley approach per SPPWC 130-3. The Contractor shall saw-cut, excavate and remove existing in-place materials as necessary and properly dispose of material, subgrade and concrete for new construction; compact subgrade; and

construct new 8" alley approach as directed and as shown per detail drawings. New alley approach shall join existing flow lines. New alley approach finish shall match existing finish and flowline. **Curb and gutter shall not be poured monolithic with the alley approach.** Removal and installation of concrete curb and gutter within the limit of ECR/BCR as part of alley replacement is considered included in bid item 15. Curb and gutter construction shall conform to requirements of bid item 17. Curb and gutter shall be variable height as needed and no additional compensation will be allowed for constructing curb higher than 8 inches. Limits of construction shall be verified, measured and marked in the field by the Engineer prior to removing existing improvements.

Sidewalks shall meet all ADA requirements and shall not create impediments to access. Sidewalks features, per standard plan, shall include:

Cross-slope not exceeding 1.5% slope
Running slope not exceeding 4.5% slope

If native soil is determined to be unsuitable for construction of new 8" alley approach, with the approval and under the direction of the engineer/inspector the contractor may excavate 4" of native soil, compact sub-grade to 90%, place and compact 4" Crushed Miscellaneous Base (CMB) prior to construction of new 8" alley approach. Removal and disposal of native soil and placement/compaction of CMB will be paid for by CMB AS NEEDED (BID ITEM 8) and shall include all excavation, including costs for trucking of material and proper disposal, compaction, regrading, labor, tools, equipment, materials, and incidentals required to complete the work in compliance with Bid Item 8. No additional compensation will be allowed.

Portland cement concrete material shall be Portland Cement Concrete of Type 560-C-3250. Slot Patch should be Type C2 PG 64-10, 1 foot wide and 8 inch depth.

The Contractor shall replace and repair any irrigation system damaged by his operation in all locations. In some locations, there may be tree roots that need to be removed for proper construction of the improvements. In these cases, the Contractor, at his own expenses, shall cut, remove, and properly dispose the roots per Engineer instructions and per all applicable laws, rules and regulations. All work necessary to remove and properly dispose of all removed material shall be at no extra cost to the CITY.

Payment for root pruning within the limits of the alley apron shall be included in the contract bid price.

These pruning guidelines shall be followed by all persons or firms repairing or replacing damaged street, curbs, sidewalks, driveways, or access ramps where the damage is attributable to the roots of the trees growing in the public right-of-way. At least two (2) days prior to any digging or excavating, DigAlert and the Parks Department at 562-383-4170, must be notified.

The Contractor shall remove the concrete at all tree root locations and notify the Parks Department forty-eight (48) hours in advance prior to performing root pruning or selective root removal.

One of the following methods or a combination of methods shall be used when pruning or root removal of tree roots:

Whenever possible, root pruning should only be performed on one side of a tree at a time, meaning on the sidewalk side or street side, but not on both, unless specifically authorized by the City Arborist.

- a. Root Pruning: The actual pruning of roots should be done using a trenching machine, which operates in a vertical motion only, with a root pruning attachment or some comparable piece of equipment, which can safely cut a narrow trench four (4) to six (6) inches wide.
- b. Selective Root Removal: Root larger than three (3) inches in diameter shall be horizontally trimmed or selectively removed. The utilization of a chain saw or other sawing tool shall be employed during this procedure. This procedure shall be overseen by the City Arborist.

All tree activity shall be conducted in a manner specified by ANSI Z133.1 – 2006 Safety Requirements & ANSI A300 (Part 1)-2001 Standard Practices (Pruning).

If the report from the City Arborist recommends the tree be removed because necessary root pruning would be detrimental to the structural integrity of the tree, the Contractor will coordinate with the CITY for removal by CITY resources.

The Contractor shall paint the address of any house that is on a replaced curb with no extra cost to CITY to the satisfaction of the Engineer.

The bid item may be increased or reduced at the discretion of the City. The provisions of Section 2-7.1 of the Greenbook governing increases or decreases in quantity of more than 25% shall not apply to this item. Unit prices shall continue to apply to the increased or decreased quantities for more and less than twenty-five percent (25%).

No open excavations will be allowed over a weekend or holiday. The Contractor shall schedule work to accommodate this requirement. All concrete must be in place and forms removed prior to weekends and holidays.

Full compensation for conforming to the requirements in this article SAWCUT AND REMOVE EXISTING ALLEY APPROACH. CONSTRUCT NEW 8" PCC ALLEY APPROACH PER SPPWC 130-3. (BID ITEM 15) shall be considered as included in the contract bid price per Square Foot (SF), and shall include all labor, tools, materials and appurtenances necessary to complete the work including costs for trucking and disposing of material and no additional compensation will be allowed therefor.

ARTICLE 12.16: SAWCUT AND REMOVE EXISTING LOCAL DEPRESSION. CONSTRUCT NEW LOCAL DEPRESSION PER SPPWC STANDARD PLAN 313-4: This bid item shall include all labor, materials, equipment, and work necessary to remove existing and construct new local depression over 6" CMB per SPPWC Standard Plan 313-4 with AC slot patch complete in place. The Contractor shall saw-cut; excavate and remove existing in-place materials as necessary and properly dispose of material, subgrade, and concrete for new construction;

compact subgrade; place 6" CMB; and construct new local depression. New curb and gutter finish shall match existing type, curb height and finish and shall maintain water flow through the flowline. Limits of construction shall be verified, measured and marked in the field by the Engineer prior to removing existing improvements. The Contractor shall construct an asphalt concrete slot twelve inches wide, 8 inch depth, with length that matches the length of the new curb and gutter. Adjustment of any existing pipe openings, removal of existing pavement and base/subgrade, and the installation of the AC slot patch shall be included in the contract bid price. New curb and depression shall be variable height as needed, match existing, and conform to requirements set forth in bid item 17, and no additional compensation will be allowed for constructing curb higher than 8 inches. Compensation for new curb and gutter as part of the local depression construction is considered included in bid item 16 and no additional compensation will be allowed therefor.

Portland cement concrete material shall be Portland Cement Concrete of Type 520-C-2500. Slot Patch should be Type C2 PG 64-10, 1 foot wide and 8 inch depth. CMB shall be per Section 200-2.4 of Greenbook and Table 200-2.4.2, fine gradation.

The Contractor shall replace and repair any irrigation system damaged by his operation in all locations. In some locations, there may be tree roots that need to be removed for proper construction of the improvements. In these cases, the Contractor, at his own expenses, shall cut, remove, and properly dispose the roots per Engineer instructions and per all applicable laws, rules and regulations. All work necessary to remove and properly dispose of all removed material shall be at no extra cost to the CITY.

Payment for root pruning within the limits of the curb and gutter shall be included in the contract bid price.

These pruning guidelines shall be followed by all persons or firms repairing or replacing damaged street, curbs, sidewalks, driveways, or access ramps where the damage is attributable to the roots of the trees growing in the public right-of-way. At least two (2) days prior to any digging or excavating, DigAlert and the Parks Department at 562-383-4170, must be notified.

The Contractor shall remove the concrete at all tree root locations and notify the Parks Department forty-eight (48) hours in advance prior to performing root pruning or selective root removal.

One of the following methods or a combination of methods shall be used when pruning or root removal of tree roots:

Whenever possible, root pruning should only be performed on one side of a tree at a time, meaning on the sidewalk side or street side, but not on both, unless specifically authorized by the City Arborist.

- a. Root Pruning: The actual pruning of roots should be done using a trenching machine, which operates in a vertical motion only, with a root pruning attachment or some comparable piece of equipment, which can safely cut a narrow trench four (4) to six (6) inches wide.

- b. Selective Root Removal: Root larger than three (3) inches in diameter shall be horizontally trimmed or selectively removed. The utilization of a chain saw or other sawing tool shall be employed during this procedure. This procedure shall be overseen by the City Arborist.

All tree activity shall be conducted in a manner specified by ANSI Z133.1 – 2006 Safety Requirements & ANSI A300 (Part 1)-2001 Standard Practices (Pruning).

If the report from the City Arborist recommends the tree be removed because necessary root pruning would be detrimental to the structural integrity of the tree, the Contractor will coordinate with the CITY for removal by CITY resources.

The Contractor shall paint the address of any house that is on a replaced curb with no extra cost to CITY to the satisfaction of the Engineer.

The bid item may be increased or reduced at the discretion of the City. The provisions of Section 2-7.1 of the Greenbook governing increases or decreases in quantity of more than 25% shall not apply to this item. Unit prices shall continue to apply to the increased or decreased quantities for more and less than twenty-five percent (25%).

No open excavations will be allowed over a weekend or holiday. The Contractor shall schedule work to accommodate this requirement. All concrete must be in place and forms removed prior to weekends and holidays.

Full compensation for conforming to the requirements in this article SAWCUT AND REMOVE EXISTING LOCAL DEPRESSION. CONSTRUCT NEW LOCAL DEPRESSION PER SPPWC STANDARD PLAN 313-4 (BID ITEM 16): shall be considered as included in the contract bid price per Square Foot (SF), and shall include all labor, tools, materials, CMB, variable curb height, and appurtenances necessary to complete the work including costs for trucking and disposing of material and no additional compensation will be allowed therefor.

ARTICLE 12.17: REMOVE AND REPLACE VARIABLE HEIGHT PCC CURB & GUTTER OVER 6" CMB PER LA HABRA STANDARD DETAIL R-13, TYPE A2-8. INCLUDES 1' SLOT CUT AND PATCH, TYPE C2 PG 64-10: This bid item shall include all labor, materials, equipment, and work necessary to remove existing and construct new variable height concrete curb & gutter over 6" CMB per CITY Standard Detail No. R-13, Type A 2-8 with AC slot patch complete in place. The Contractor shall saw-cut; excavate and remove existing in-place materials as necessary and properly dispose of material, subgrade, and concrete for new construction; compact subgrade; place 6" CMB; and construct new variable height curb and gutter. New curb and gutter finish shall match existing type, curb height and finish and shall maintain water flow through the flowline. Limits of construction shall be verified, measured and marked in the field by the Engineer prior to removing existing improvements. The Contractor shall construct an asphalt concrete slot twelve inches wide, 8 inch depth, with length that matches the length of the new curb and gutter. Adjustment of any existing pipe openings, identification and replacement of curb drains, removal of existing pavement and base/subgrade, and the installation of the AC slot patch shall be included in the contract bid price.

Portland cement concrete material shall be Portland Cement Concrete of Type 520-C-2500. Slot Patch should be Type C2 PG 64-10, 1 foot wide and 8 inch depth. CMB shall be per Section 200-2.4 of Greenbook and Table 200-2.4.2, fine gradation.

The Contractor shall replace and repair any irrigation system damaged by his operation in all locations. In some locations, there may be tree roots that need to be removed for proper construction of the improvements. In these cases, the Contractor, at his own expenses, shall cut, remove, and properly dispose the roots per Engineer instructions and per all applicable laws, rules and regulations. All work necessary to remove and properly dispose of all removed material shall be at no extra cost to the CITY.

Repair Damaged Curb: Remove loose concrete pieces and unsound concrete, wash concrete surface to receive fill concrete with high pressure water, install dowel (No. 3) as necessary to secure fill concrete to existing curb, place forms, apply concrete bonding agent, place fill concrete, consolidate concrete, remove forms when set, finish concrete surface, backfill and cleanup. Compensation for repairing damaged curbs are included in this bid item shall be paid at the contract price of (LF) and shall include full compensation for furnishing all labor, materials, tools, equipment, fabricating, installing, incidentals and all other work involved, complete in place and no additional compensation will be allowed thereof.

Payment for root pruning within the limits of the curb and gutter shall be included in the contract bid price.

These pruning guidelines shall be followed by all persons or firms repairing or replacing damaged street, curbs, sidewalks, driveways, or access ramps where the damage is attributable to the roots of the trees growing in the public right-of-way. At least two (2) days prior to any digging or excavating, DigAlert and the Parks Department at 562-383-4170, must be notified.

The Contractor shall remove the concrete at all tree root locations and notify the Parks Department forty-eight (48) hours in advance prior to performing root pruning or selective root removal.

One of the following methods or a combination of methods shall be used when pruning or root removal of tree roots:

Whenever possible, root pruning should only be performed on one side of a tree at a time, meaning on the sidewalk side or street side, but not on both, unless specifically authorized by the City Arborist.

- a. Root Pruning: The actual pruning of roots should be done using a trenching machine, which operates in a vertical motion only, with a root pruning attachment or some comparable piece of equipment, which can safely cut a narrow trench four (4) to six (6) inches wide.
- b. Selective Root Removal: Root larger than three (3) inches in diameter shall be horizontally trimmed or selectively removed. The utilization of a chain saw or other sawing tool shall be employed during this procedure. This procedure shall be overseen by the City Arborist.

All tree activity shall be conducted in a manner specified by ANSI Z133.1 – 2006 Safety Requirements & ANSI A300 (Part 1)-2001 Standard Practices (Pruning).

If the report from the City Arborist recommends the tree be removed because necessary root pruning would be detrimental to the structural integrity of the tree, the Contractor will coordinate with the CITY for removal by CITY resources.

The Contractor shall paint the address of any house that is on a replaced curb with no extra cost to CITY to the satisfaction of the Engineer.

The bid item may be increased or reduced at the discretion of the City. The provisions of Section 2-7.1 of the Greenbook governing increases or decreases in quantity of more than 25% shall not apply to this item. Unit prices shall continue to apply to the increased or decreased quantities for more and less than twenty-five percent (25%).

No open excavations will be allowed over a weekend or holiday. The Contractor shall schedule work to accommodate this requirement. All concrete must be in place and forms removed prior to weekends and holidays.

Full compensation for conforming to the requirements in this article REMOVE AND REPLACE VARIABLE HEIGHT PCC CURB & GUTTER OVER 6" CMB PER LA HABRA STANDARD DETAIL R-13, TYPE A2-8. INCLUDES 1' SLOT CUT AND PATCH, TYPE C2 PG 64-10 (BID ITEM 17): shall be considered as included in the contract bid price per Linear Foot (LF), and shall include all labor, tools, materials, CMB, and appurtenances necessary to complete the work including costs for trucking and disposing of material and no additional compensation will be allowed therefor.

ARTICLE 12.18: SAWCUT AND REMOVE EXISTING CURB RAMP. CONSTRUCT NEW 4" PCC CURB RAMP OVER COMPACTED NATIVE SOIL PER CALTRANS STANDARD PLAN RSP A88A, AS NOTED ON PLAN OR DIRECTED BY CITY IN FIELD, 1' WIDE AC SLOT PATCH.

This bid item shall include all labor, materials, equipment, and work necessary to remove existing and construct new PCC curb ramp with detectable warning surface per Caltrans Revised Standard Plan RSP A88A, case per plans, unless otherwise noted or directed by City in field, complete in place over compacted native soil. This bid item includes excavation and disposal of existing ramp, subgrade, native soil as needed for construction of ADA complaint curb ramp. PCC curb ramp shall be placed over compacted native soil.

If native soil is determined to be unsuitable for construction of new PCC curb ramp, with the approval and under the direction of the engineer/inspector the contractor may excavate 4" of native soil, compact sub-grade to 90%, place and compact 4" Crushed Miscellaneous Base (CMB) prior to construction of new PCC curb ramp. Removal and disposal of native soil and placement/compaction of CMB will be paid for by CMB AS NEEDED (BID ITEM 8) and shall include all excavation, including costs for trucking of material and proper disposal including,

compaction, regrading, labor, tools, equipment, materials, and incidentals required to complete the work in compliance with Bid Item 8. No additional compensation will be allowed.

Retaining curb shall be increased in height as needed to match existing grade and is considered included in Bid Item 18 and no additional compensation will be allowed therefor. The Contractor shall saw-cut and remove existing PCC sidewalk, curbs, gutter, spandrels, sand, subgrade and other in-place materials as necessary and properly dispose of material, subgrade, and concrete for new construction; compact subgrade; and construct new PCC curb ramps with detectable warning surface where noted and as shown per detail drawings. New sidewalk shall match existing sidewalk finish and pattern as directed. **The Limits of construction for pedestrian ramps is considered within the BCR to ECR and this bid item shall include curb ramp related sidewalk, retaining curb, variable height curb, 6" CMB under curb and gutter, gutter, curb drain and 1' WIDE FULL DEPTH AC slot patch. Additionally, all related adjustments of pull boxes, pull box covers, protection or sign replacements within construction limits shall be considered as part of the ramp work and shall be included in the contract bid price.**

This bid item shall include placement of 6" CMB under curb and gutter within the ECR and BCR and shall conform to requirements outlined in bid item 17 "Remove and Replace variable height PCC Curb & Gutter over 6" CMB per La Habra STANDARD Detail R-13, Type A2-8. Includes 1' Slot Cut and Patch, Type C2 PG 64-10." Compensation for placing 6" CMB under curb and gutter within BCR/ECR is considered included in Bid Item 18 and no additional compensation will be allowed therefor.

Sidewalks, curb and gutters, 1' WIDE FULL DEPTH AC slot patch, and PCC retaining curbs outside of the BCR/ECR shall be paid for through bid items 12, 17, 19.

New curb ramp finish shall match existing sidewalk type, curb height and finish and shall maintain water flow through the flowline. Limits of construction shall be verified, measured and marked in the field by the Engineer prior to removing existing improvements. The Contractor shall construct an asphalt concrete slot twelve inches wide with length that matches the length of the new curb and gutter and 8 inch depth. Adjustment of any existing pipe openings, removal of existing pavement and base/subgrade, and the installation of the AC slot patch shall be included in the contract bid price. For curb ramps that are joined to a spandrel, the Contractor shall sawcut a neat line 4" from the existing curb face.

Portland cement concrete material shall be Portland Cement Concrete of Type 520-C-2500. Slot Patch should be Type C2 PG 64-10, 1 foot wide and 8 inch depth. CMB shall be per Section 200-2.4 of Greenbook and Table 200-2.4.2, fine gradation.

Integral retaining curbs shall be constructed at the back of curb ramps and sidewalks as necessary to match existing landscape grades or to match existing grades at a wall. Integral curbs, curb and gutter, and sidewalk shall be constructed as shown on the plans.

Curb access ramps and sidewalks shall meet all ADA requirements and shall not create impediments to access. Curb access ramps features, per standard plan, shall include:

ramps not exceeding 7.5% slope
flares not exceeding 9% slope at the curb
turning space of 4'-2" by 4'-2" minimum area and maximum cross slopes of 1.5% for all direction
bottom of ramps to be flush to gutters; The gutter width shall be 2' and not exceed 5% counter slope
integral retaining curbs as necessary to match to existing landscape grades

Detectable warning surface shall conform to the standard plans and shall be precast tactile tiles by Armor-Tile or approved equal, 3'x4' minimum, extending the full width of ramp. Edge of detectable warning tile is to be 6" to 8" from the flowline at the bottom of the ramp and parallel to adjacent to the street or tangent to the curb return. The color of the detectable warning surface shall be Dark Gray unless otherwise specified.

The Contractor shall submit to the Engineer for review the following items:

- A. Product Data: Submit manufacturer's literature describing products, installation procedures and routine maintenance.
- B. Samples: Submit two tile samples of the kind proposed for use (minimum size 6" by 8").
- C. Materials Test Reports: Submit test reports from qualified independent testing laboratory indicating that materials proposed for use are in compliance with requirements and meet the properties indicated. All test reports shall be conducted on a cast-in-place tactile tile system as certified by a qualified independent testing laboratory.
- D. Maintenance Instructions: Submit copies of manufacturer's specified maintenance practices for each type of tactile tile and accessory as required.

The manufacturer shall provide a written five-year warranty for prefabricated detectable warning surfaces, guaranteeing replacement when there is defect in the dome shape, color fastness, sound-on-cane acoustic quality, resilience, or attachment. The warranty period shall begin upon acceptance of the project.

Note: Midblock pedestrian ramps – Ramp Detail A – Bollard Relocation and Asphalt Pathway

Compensation for construction of Midblock Pedestrians ramps will be included in this bid item 18 and is as follows:

The limits of construction or area that is included in the midblock pedestrian ramps includes all details shown on detail A of the plans except for PCC retaining curb, curb and gutter, asphalt work, redwood header, which will be paid through bid items 11, 17, 19 and 24; and shall conform to said bid items.

The contractor will excavate variable full depth AC behind midblock pedestrian ramps (as shown on Detail A) a minimum of 10 feet into walking path, regrade to match new PCC sidewalk, and construct 4" C2 PG 64-10 pedestrian walkway in one or two lifts over compacted native soil with

a variable width as needed to match PCC sidewalk. All surface preparation, excavation, milling, compaction, mobilization/demobilization, rock dust blotter, labor, tools, equipment, materials, including costs for proper disposal and trucking of material, and incidentals required to complete the work shall be considered included in the contract bid price for **Bid Item 11** and no additional compensation will be allowed therefor. Asphalt Concrete placed as part of this bid item shall conform to sections 203 and 302-5 of the SSPWC except as modified here in. The temperature of asphalt shall conform to section 203-1.4 of the SSPWC and Distribution and spreading shall conform to section 302-5.5.

Contract shall relocate bollards as shown per plans or directed by City in the field. Contractor shall remove existing bollard, backfill excavations with clean soil, remove residual concrete from bollard and place bollard in new foundation per the following criteria: (Width: Length: Depth – 16 inch: 16 inch: 24 inch) Portland Cement Concrete Type 520-C-2500. Contractor shall pothole for existing utilities prior to excavation for new foundation. Any utilities damaged by contractor operations shall be replaced in kind at no additional cost to the City. All surface preparation, excavation, compaction, forming, labor, tools, equipment, materials, including costs for proper disposal and trucking of material, and incidentals required to complete the work is shall be considered as included in the contract bid price for **Bid Item 18** and no additional compensation will be allowed therefore.

The midblock pedestrian ramp shall be constructed in conformance with 2018 Caltrans Standard Plans A88A - Case A. The landing behind the ramp shall have a max 1.5% cross slope and a max 1.5% running slope in conformance with Caltrans Standard Plans A88A – Case A.

The Contractor shall replace and repair any irrigation system damaged by his operation in all locations. In some locations, there may be tree roots that need to be removed for proper construction of the improvements. In these cases, the Contractor, at his own expenses, shall cut, remove, and properly dispose the roots per Engineer instructions and per all applicable laws, rules and regulations. All work necessary to remove and properly dispose of all removed material shall be at no extra cost to the CITY.

Payment for root pruning within the limits of the curb ramp shall be included in the contract bid price.

These pruning guidelines shall be followed by all persons or firms repairing or replacing damaged street, curbs, sidewalks, driveways, or access ramps where the damage is attributable to the roots of the trees growing in the public right-of-way. At least two (2) days prior to any digging or excavating, DigAlert and the Parks Department at 562-383-4170, must be notified.

The Contractor shall remove the concrete at all tree root locations and notify the Parks Department forty-eight (48) hours in advance prior to performing root pruning or selective root removal.

One of the following methods or a combination of methods shall be used when pruning or root removal of tree roots:

Whenever possible, root pruning should only be performed on one side of a tree at a time, meaning on the sidewalk side or street side, but not on both, unless specifically authorized by the City Arborist.

- a. Root Pruning: The actual pruning of roots should be done using a trenching machine, which operates in a vertical motion only, with a root pruning attachment or some comparable piece of equipment, which can safely cut a narrow trench four (4) to six (6) inches wide.
- b. Selective Root Removal: Root larger than three (3) inches in diameter shall be horizontally trimmed or selectively removed. The utilization of a chain saw or other sawing tool shall be employed during this procedure. This procedure shall be overseen by the City Arborist.

All tree activity shall be conducted in a manner specified by ANSI Z133.1 – 2006 Safety Requirements & ANSI A300 (Part 1)-2001 Standard Practices (Pruning).

If the report from the City Arborist recommends the tree be removed because necessary root pruning would be detrimental to the structural integrity of the tree, the Contractor will coordinate with the CITY for removal by CITY resources.

No open excavations will be allowed over a weekend or holiday. The Contractor shall schedule work to accommodate this requirement. All concrete must be in place and forms removed prior to weekends and holidays.

The Curb Ramp limits shall be understood to be contained within a radial line from the BCR (beginning of curb return) to a radial line at ECR (end of curb return), or 5ft past the start of ramp transition and sidewalk join location to provide a sidewalk transition; whichever is greater.

Full compensation for conforming to the requirements in this article SAWCUT AND REMOVE EXISTING CURB RAMP. CONSTRUCT NEW 4" PCC CURB RAMP OVER COMPACTED NATIVE SOIL PER CALTRANS STANDARD PLAN RSP A88A, AS NOTED ON PLAN OR DIRECTED BY CITY IN FIELD, 1' WIDE AC SLOT PATCH. (BID ITEM 18) shall be considered as included in the contract bid price per Each (EA), and shall include all labor, tools, materials and appurtenances necessary to complete the work and no additional compensation will be allowed therefor. The Contractor shall be responsible to remove and reconstruct curb access ramps at his own cost if the ramps are deemed non-compliant with project plans and specifications.

ARTICLE 12.19: CONSTRUCT PCC RETAINING CURB: This bid item shall include all labor, materials, equipment, and work necessary to excavate and remove existing in-place materials and construct 6" wide and 6" minimum height PCC retaining curb over compacted native soil complete in place. Retaining curbs shall be a minimum height of 6" inches but shall be increased in height as needed to match existing landscape grades; the increase in retaining curb height is considered inclusive of this bid item. Retaining curb shall be poured monolithic with sidewalk and shall

include construction radially curved retaining curbs. of Limits of construction shall be verified, measured and marked in the field by the Engineer prior to removing existing improvements.

Retaining curb shall be Portland cement concrete material shall be Portland Cement Concrete of Type 520-C-2500. CMB shall be per Section 200-2.4 of Greenbook and Table 200-2.4.2, fine gradation.

If native soil is determined to be unsuitable for construction of new retaining curb, with the approval and under the direction of the engineer/inspector the contractor may excavate 4" of native soil, compact sub-grade to 90%, place and compact 4" Crushed Miscellaneous Base (CMB) prior to construction of new retaining curb. Removal and disposal of native soil and placement/compaction of CMB will be paid for by CMB AS NEEDED (BID ITEM 8) and shall include all excavation, including costs for trucking of material and proper disposal, compaction, regrading, labor, tools, equipment, materials, and incidentals required to complete the work in compliance with Bid Item 8. No additional compensation will be allowed.

The Contractor shall replace and repair any irrigation system damaged by his operation in all locations. In some locations, there may be tree roots that need to be removed for proper construction of the improvements. In these cases, the Contractor, at his own expenses, shall cut, remove, and properly dispose the roots per Engineer instructions and per all applicable laws, rules and regulations. All work necessary to remove and properly dispose of all removed material shall be at no extra cost to the CITY.

Payment for root pruning within the limits of the PCC retaining curb shall be included in the contract bid price.

These pruning guidelines shall be followed by all persons or firms repairing or replacing damaged street, curbs, sidewalks, driveways, or access ramps where the damage is attributable to the roots of the trees growing in the public right-of-way. At least two (2) days prior to any digging or excavating, DigAlert and the Parks Department at 562-383-4170, must be notified.

The Contractor shall remove the concrete at all tree root locations and notify the Parks Department forty-eight (48) hours in advance prior to performing root pruning or selective root removal.

One of the following methods or a combination of methods shall be used when pruning or root removal of tree roots:

Whenever possible, root pruning should only be performed on one side of a tree at a time, meaning on the sidewalk side or street side, but not on both, unless specifically authorized by the City Arborist.

- a. Root Pruning: The actual pruning of roots should be done using a trenching machine, which operates in a vertical motion only, with a root pruning attachment or some comparable piece of equipment, which can safely cut a narrow trench four (4) to six (6) inches wide.
- b. Selective Root Removal: Root larger than three (3) inches in diameter shall be horizontally trimmed or selectively removed. The utilization of a chain saw or other

sawing tool shall be employed during this procedure. This procedure shall be overseen by the City Arborist.

All tree activity shall be conducted in a manner specified by ANSI Z133.1 – 2006 Safety Requirements & ANSI A300 (Part 1)-2001 Standard Practices (Pruning).

If the report from the City Arborist recommends the tree be removed because necessary root pruning would be detrimental to the structural integrity of the tree, the Contractor will coordinate with the CITY for removal by CITY resources.

The bid item may be increased or reduced at the discretion of the City. The provisions of Section 2-7.1 of the Greenbook governing increases or decreases in quantity of more than 25% shall not apply to this item. Unit prices shall continue to apply to the increased or decreased quantities for more and less than twenty-five percent (25%).

Full compensation for conforming to the requirements in this article CONSTRUCT PCC RETAINING CURB (BID ITEM 19) shall be considered as included in the contract bid price per LINEAR FOOT (LF), and shall include all labor, tools, materials and appurtenances necessary to complete the work including costs for trucking and disposing of material and no additional compensation will be allowed therefor.

ARTICLE 12.20: ADJUST MANHOLE TO GRADE: This bid item shall include all labor, tools, materials, and appurtenances necessary to adjust sewer, storm drain, and water manhole covers and vault covers to grade (except for utility covers, lids, and other utility structures which are adjusted by others or are covered under item ADJUST VALVES TO GRADE). The work shall include, but not be limited to, saw-cut, excavation, removal and proper disposal of removed material, as well as protection, removal or lowering of the utility structure during demolition and preparation, setting the structure to grade, and forming pavement or other constructed work around the structure. The work may include replacement with a new structure or cover to be provided by others. The finished adjustment shall be flush to adjacent surfaces and of sufficient strength to support anticipated traffic. All utility adjustment work and safety requirements shall be coordinated with the appropriate utility agency. Additional adjustments shall be necessary to keep the valve lid level with the surrounding pavement as the pavement is lowered and raised during the construction process. At no additional cost to City, the contractor shall coordinate with other utilities as noted on plan for adjustments of their utilities.

The bid item may be increased or reduced at the discretion of the City. The provisions of Section 2-7.1 of the Greenbook governing increases or decreases in quantity of more than 25% shall not apply to this item. Unit prices shall continue to apply to the increased or decreased quantities for more and less than twenty-five percent (25%).

Full compensation for conforming to the requirements in this article ADJUST MANHOLE TO GRADE (BID ITEM 20) shall be considered as included in the contract bid price per Each (EA), and shall include all labor, tools, materials and appurtenances necessary to complete the work and no additional compensation will be allowed therefor.

ARTICLE 12.21: ADJUST VALVE FRAME AND COVER TO GRADE: This bid item shall include all labor, tools, materials, and appurtenances necessary to adjust valves to grade. The work shall include, but not be limited to, saw-cut, excavation, removal, and proper disposal of removed material, as well as protection, removal or lowering of the water valve during demolition and preparation, setting the structure to grade, and forming pavement or other constructed work around the structure. The work may include replacement with a new structure or cover to be provided by others. The finished adjustment shall be flush to adjacent surfaces and of sufficient strength to support anticipated traffic. All utility adjustment work and safety requirements shall be coordinated with the appropriate utility agency. Contractor shall adjust valves belonging to utility agencies as noted per the plan and coordinate with appropriate utility agency for adjustments. If a lid or cover is to be replaced, the Contractor shall coordinate said replacement with the appropriate utility agency.

The CITY Water Department will provide the Contractor with new utility covers, in lieu of damaged covers, to install and adjust to grade per CITY standard Detail W-4.

The Contractor shall remove all debris from within valve sleeves. Additional adjustments shall be necessary to keep the valve lid level with the surrounding pavement as the pavement is lowered and raised during the construction process.

The bid item may be increased or reduced at the discretion of the City. The provisions of Section 2-7.1 of the Greenbook governing increases or decreases in quantity of more than 25% shall not apply to this item. Unit prices shall continue to apply to the increased or decreased quantities for more and less than twenty-five percent (25%).

Full compensation for conforming to the requirements in this article ADJUST VALVE FRAME AND COVER TO GRADE (BID ITEM 21) shall be considered as included in the contract bid price per Each (EA), and shall include all labor, tools, materials and appurtenances necessary to complete the work and no additional compensation will be allowed therefor.

ARTICLE 12.22: REPLACE METER BOX AND LID: The contract bid item for replacement Meter Box shall include all labor, work, incidentals, materials necessary to furnish new meter box and install at finished grade. All utility adjustment work and safety requirements shall be coordinated with the appropriate utility agency.

The contractor shall remove existing meter box, lid, and subgrade material as needed and install new meter box and lid in the sidewalk or driveway and match new grade as noted on plan or as directed by city in field. Meter boxes in driveway shall be traffic rated meter boxes and have H20 traffic rated lids. Meter boxes shall be installed per La Habra Standard Detail W-6, or W-6a. Meter Box shall be of the manufacture and model listed in W-6, W-6a, Brooks 3MB Specification included in detail, or approved equal. New Meter boxes shall match existing size. Meter box and lid size shall be approved by City of La Habra Water Division prior to installation.

The bid item may be increased or reduced at the discretion of the City. The provisions of Section 2-7.1 of the Greenbook governing increases or decreases in quantity of more than

25% shall not apply to this item. Unit prices shall continue to apply to the increased or decreased quantities for more and less than twenty-five percent (25%).

Full compensation for complying with the work contained in this section shall be included in the contract price bid per EACH (EA) to REPLACE METER BOX AND LID (BID ITEM 22), shall be considered as included in the contract bid price per Each (EA), and shall include all labor, tools, materials and appurtenances necessary to complete the work and no additional compensation will be allowed therefor.

ARTICLE 12.23: INSTALL 6-FOOT TRAFFIC SIGNAL LOOP DETECTORS: This bid item shall include all labor, tools, materials and appurtenances necessary to install traffic signal loop detectors. The Contractor shall install Type E and Type F loops, as shown per plan and in accordance with Section 86 and 87 of the Standard Specifications and Caltrans Standard Plan No. ES-5A and ES-5B, except as modified or supplemented herein. Loop detectors shall have a 6' diameter. Front loops shall be bicycle compatible, Type F loops.

Loop detector sealant shall consist of hot melt rubber asphalt sealant, in accordance with 86-1.02W, "Loop Detector Sealants," and 87-1.03V, "Detectors," of the Caltrans Standard Specifications.

Existing loop leads shall be disconnected at the termination pull boxes prior to construction operations. New loop detectors shall be spliced to existing DLC's.

Maintain Traffic Signals

Existing traffic signals or approved temporary replacements shall be kept in effective operation for the benefit of the traveling public during the process of the work, except when shutdown is permitted, to allow for alterations of the system. The traffic signal shutdowns shall be limited to normal working hours or shall be as specified in the Special Provisions. The Contractor shall notify the Engineer prior to performing any work on existing systems.

The Contractor shall notify the Engineer and local traffic enforcement agency prior to any operational shutdown of a traffic signal.

All installation and maintenance of temporary traffic signals shall be the responsibility of the Contractor, and furnished and installed as required to maintain safe and acceptable traffic conditions.

NO ADDITIONAL COMPENSATION WILL BE ALLOWED FOR ADDITIONAL MOVE-INS REQUIRED TO CONFORM WITH PHASING SEQUENCING.

No additional compensation will be allowed for removal of concrete containing reinforcing or other steel.

Full compensation for conforming to the requirements in this article INSTALL 6-FOOT TRAFFIC SIGNAL LOOP DETECTORS (BID ITEM 23) shall be considered as included in the contract bid price per Each (EA), and shall include, but not be limited to, full compensation for obtaining required permits with fees, phasing, temporary traffic signals, removals, replacements and

pavement restoration, all labor, tools, materials and appurtenances necessary to complete the work and no additional compensation will be allowed therefor.

ARTICLE 12.24: CONSTRUCT HEADER BOARD WITH STAKES: The contract bid item to furnish, construct the Header Board (Redwood Header) and stakes include all labor, work and materials necessary to remove existing materials, grade and backfill as required and construct the redwood header complete in place. The Contractor shall sawcut and remove existing asphalt, landscape and other materials, base, subgrade, and other in-place materials as necessary for construction; prepare the subgrade; grade; and construct the redwood header where noted and as shown per detail drawings. Stakes shall be placed at 2 feet on-center at 12 inch depth.

The bid item may be increased or reduced at the discretion of the City. The provisions of Section 2-7.1 of the Greenbook governing increases or decreases in quantity of more than 25% shall not apply to this item. Unit prices shall continue to apply to the increased or decreased quantities for more and less than twenty-five percent (25%).

Full compensation for complying with the work contained in this section shall be included in the contract price bid per LINEAR FOOT (LF) to CONSTRUCT HEADER BOARD WITH STAKES (BID ITEM 24), and no additional compensation will be allowed therefore.

ARTICLE 12.25: REMOVE EXISTING AND INSTALL MAILBOX: The contract bid item to remove existing mail box and relocate and shall include all labor, work and materials necessary to remove existing mailbox and relocate complete in place.

Relocation of Mailbox at 350 South Monte Vista Street.

Relocate mailbox from parkway to back of sidewalk location as directed by Inspector or Engineer. The work under this bid items shall include removal of existing mailbox or various mailboxes in mailbox set, removal of existing mailbox foundation to one (1) foot below the surface, backfill with clean dirt, recompact, saw grass seeds, construct mailbox concrete foundation, repair and/or replace damaged mailbox wood members, clean, prep., prime and paint wood members, two coats, color to be selected by Inspector or engineer, clean mailboxes, reset mailbox in new foundation, relocate and repair affected existing irrigation, reset existing sod, clean area, per County of Orange Standard No. 1212 or match existing and the property owners preference and approval. The mailbox is to be relocated in one day, so as not to affect mail delivery. Coordinate with Post Office as necessary and property owner. This bid item shall be paid at the contract price per each (EA) and shall include full compensation for furnishing all labor, materials, tools, equipment, fabricating, installing, incidentals and all other work involved, complete in place and no additional compensation will be allowed thereof.

Relocation of Mailbox at 341 South Monte Vista Street.

Relocate mailbox from sidewalk to back of sidewalk location, behind retaining wall, as directed by Inspector or Engineer. The work under this bid items shall include removal of existing mailbox

or various mailboxes in mailbox set, removal of existing mailbox foundation to one (1) foot below the surface, restore concrete sidewalk, modify existing chainlink fence to allow for mailbox relocation, construct mailbox concrete foundation, repair and/or replace damaged mailbox wood members, clean, prep., prime and paint wood members, two coats, color to be selected by Project Inspector or Engineer, clean mailboxes, reset mailbox in new foundation, relocate and repair affected existing irrigation, reset existing landscaping, clean area, per County of Orange Standard No. 1212 or match existing and the property owners preference and approval. The mailbox is to be relocated in one day, so as not to affect mail delivery. Coordinate with Post Office as necessary and property owner. This bid item shall be paid at the contract price per each (EA) and shall include full compensation for furnishing all labor, materials, tools, equipment, fabricating, installing, incidentals and all other work involved, complete in place and no additional compensation will be allowed thereof.

Full compensation for complying with the work contained in this section shall be included in the contract price bid per EACH (EA) to REMOVE EXISTING AND INSTALL MAILBOX (BID ITEM 25), and shall include full compensation for furnishing all labor, materials, tools, equipment, fabricating, installing, incidentals and all other work involved, complete in place and no additional compensation will be allowed therefor.

SECTION D

PROPOSAL

PROPOSAL

City of La Habra
Civic Center
110 E. La Habra Blvd.
La Habra, California 90631

Gentlemen:

The undersigned hereby proposes to perform all work for which a contract may be awarded him and to furnish any and all plant, labor, services, materials, tools, equipment, supplies, transportation, utilities, and all other items and facilities necessary therefor as provided in the Contract Documents, and to do everything required therein for the project specifically set forth in documents entitled:

**MONTE VISTA STREET REHABILITATION PROJECT
FISCAL YEAR 2022-2023
CITY PROJECT NO. 2-R-22**

together with appurtenances thereto, all as set forth on the drawing and in the specifications and other Contract Documents; and, he further proposes and agrees that if this Proposal is accepted he will contract in the form and manner stipulated to perform all the work called for by drawings, specifications and other Contract Documents and to complete all such work in strict conformity therewith within the time limits set forth therein, and that he will accept as full payment therefor the prices set forth in the Bid Schedule forming a part hereof.

A *(Cashier’s Check) *(Certified Check) *(Bid Bond) properly made payable to City of La Habra hereinafter designated as the Owner for the sum of _____ dollars (\$ _____), which amount is not less than ten percent (10%) of the total amount of this bid, is attached hereto and is given as a guarantee that the undersigned will execute the Agreement and furnish the required bonds if awarded the Contract; and, in case of failure to do so within the time provided the proceeds of said check shall be forfeited to the *Owner/Sureties Liability to the Owner for forfeiture of the face amount of the Bond shall be considered as established.

(*) Delete inapplicable word or phrase.

It is understood and agreed that:

1. The undersigned has carefully examined all the Contract Documents which will form a part of the Contract;
2. The undersigned has, by investigation of the site of the work and otherwise, satisfied himself as to the nature and location of the work and has fully informed himself as to all conditions and matters which can in any way affect the work or the cost thereof;
3. The undersigned fully understands the scope of the work and has checked carefully all words and figures inserted in this proposal and he further understands that the Owner will in no way be responsible for any errors or omissions in the preparation of this proposal;

4. The undersigned will execute the Agreement and furnish the required Performance and Payment Bonds and proof of insurance coverage, within ten (10) days (not including Saturdays, Sundays and holidays) after notice to him of acceptance of his bid by the Owner; and further, that this bid may not be withdrawn for a period of sixty (60) days after the date set for the opening thereof, unless otherwise required by law. If any bidder shall withdraw his bid within said period, the Contractor shall be liable under the provisions of the Bid Security or the Contract and his surety shall be liable under the Bid Bond, as the case may be;
5. The undersigned hereby certifies that this proposal is genuine and not sham or collusive or made in the interest or in behalf of any person not herein named and the undersigned has not directly or indirectly induced or solicited any other bidder to put in a sham bid or any other person, firm or corporation to refrain from bidding; the undersigned has not in any manner sought by collusion to secure for himself an advantage over any other bidder;
6. In conformance with current statutory requirements of Section 1860, et seq., of the Labor Code of the State of California, the undersigned confirms the following as his certification:

I am aware of the provisions of Section 3700 of the Labor Code which requires every employer to be insured against liability of worker's compensation or to undertake in accordance with the provisions before commencing the performance of the work of this contract.

NOW, in compliance with the Notice Inviting Bids and all the provisions hereinbefore stipulated, the undersigned, with full cognizance thereof, hereby proposes to perform the entire work for the prices set forth in the attached Bid Schedule upon which award of the Contract is made.

Date: _____, 2024

Bidder _____

By _____

Title _____

Bidder's Post Office Address:

Corporation organized under
 the laws of the State of _____

Names and addresses of all owners
of the firm or names and titles of
all officers of the corporation:

(corporate seal)

BIDDER'S INFORMATION

Contractor's License No. _____ Expiration Date _____

Classification of Contractor's License No. _____

Contractor _____
(name of firm)

By _____
(signature) (title)

Business Address: _____

Phone () _____

I/We certify that the information provided above is complete and true to the best of my/our knowledge.

Contractor

Date

Contractor's DIR Public Works Registration No. _____

BID SCHEDULE**MONTE VISTA STREET REHABILITATION PROJECT**
FISCAL YEAR 2022-2023, CITY PROJECT NO. 2-R-22

| ITEM | DESCRIPTION | QUANTITY | UNIT | UNIT PRICE | AMOUNT |
|-------------|--|-----------------|-------------|-------------------|---------------|
| 1 | MOBILIZATION/ DEMobilIZATION (Not to Exceed Five Percent (5%) of the total bid amount) | 1 | LS | | |
| 2 | TRAFFIC CONTROL, SAFETY, AND CLEANUP (Not to Exceed Five Percent (5%) of the total bid amount) | 1 | LS | | |
| 3 | CORNER RECORDS, CONSTRUCTION STAKING AND MONUMENT PERPETUATION | 1 | LS | | |
| 4 | STORM WATER BEST MANAGEMENT PRACTICES (BMPs) | 1 | LS | | |
| 5 | TRAFFIC SIGNING, STRIPING, PAVEMENT MARKERS AND PAVEMENT MARKINGS | 1 | LS | | |
| 6 | UNCLASSIFIED EXCAVATION AND DISPOSAL | 510 | CY | | |
| 7 | COLD MILL EXISTING AC PAVEMENT TO 2" DEPTH | 77,600 | SF | | |
| 8 | CMB (CRUSHED MISCELLANEOUS BASE) AS NEEDED | 470 | TON | | |
| 9 | INSTALL 4" THICK ASPHALT CONCRETE BASE COURSE (B PG 64-10) | 690 | TON | | |
| 10 | INSTALL 2" THICK ASPHALT RUBBER HOT MIX (ARHM) OVERLAY (ARHM-GG-C PG 64-16). | 1,250 | TON | | |
| 11 | REMOVE EXISTING, GRADE AND INSTALL 4" THICK ASPHALT CONCRETE PAVEMENT (C2 PG 64-10) | 20 | TON | | |

| | | | | | |
|----|--|-------|----|--|--|
| 12 | SAWCUT AND REMOVE EXISTING SIDEWALK. CONSTRUCT NEW 4" THICK PCC SIDEWALK OVER COMPACTED NATIVE SOIL | 3,440 | SF | | |
| 13 | SAWCUT AND REMOVE EXISTING CROSS-GUTTER AND SPANDREL. CONSTRUCT NEW 8" PCC GROSS-GUTTER AND SPANDREL PER LA HABRA STD. DETAIL R-6 OVER 6" CMB, 1' WIDE AC SLOT PATCH, TYPE C2 PG 64-10 | 950 | SF | | |
| 14 | SAWCUT AND REMOVE EXISTING DRIVEWAY APPROACH. CONSTRUCT NEW 6" PCC DRIVEWAY APPROACH PER SPPWC 110-2. | 810 | SF | | |
| 15 | SAWCUT AND REMOVE EXISTING ALLEY APPROACH. CONSTRUCT NEW 8" PCC ALLEY APPROACH PER SPPWC 130-3 | 340 | SF | | |
| 16 | SAWCUT AND REMOVE EXISTING LOCAL DEPRESSION PER SPPWC STANDARD PLAN 313-4 | 200 | SF | | |
| 17 | REMOVE AND REPLACE VARIABLE HEIGHT PCC CURB & GUTTER OVER 6" CMB PER LA HABRA STANDARD DETAIL R-13, TYPE A2-8, INCLUDES 1' SLOT CUT AND PATCH, TYPE C2 PG 64-10. | 550 | LF | | |
| 18 | SAWCUT AND REMOVE EXISTING CURB RAMP. CONSTRUCT NEW 4" PCC CURB RAMP OVER COMPACTED NATIVE SOIL PER CALTRANS STANDARD PLAN RSP A88A, AS NOTED ON PLAN OR DIRECTED BY CITY IN FIELD, 1' WIDE AC SLOT PATCH. | 12 | EA | | |
| 19 | CONSTRUCT PCC RETAINING CURB | 80 | LF | | |

| | | | | | |
|----|--|----|----|--|--|
| 20 | ADJUST MANHOLE TO GRADE | 27 | EA | | |
| 21 | ADJUST VALVE FRAME AND COVER TO GRADE | 18 | EA | | |
| 22 | REPLACE METER BOX AND LID | 15 | EA | | |
| 23 | INSTALL 6-FOOT TRAFFIC SIGNAL LOOP DETECTORS | 4 | EA | | |
| 24 | CONSTRUCT HEADER BOARD WITH STAKES | 60 | LF | | |
| 25 | RELOCATE MAILBOX | 2 | EA | | |

TOTAL BID PRICE FOR BID SCHEDULE IN FIGURES: \$ _____

TOTAL BID PRICE FOR BID SCHEDULE IN WORDS: _____

Note: Excavation is included in the various bid items.

Note: The TOTAL BID PRICE shall be used as the basis of bid in determining the low bid for this project.

CONTRACTOR

BY

TITLE

DATE

ACKNOWLEDGEMENT OF ADDENDA RECEIVED

The Bidder shall acknowledge the receipt of addenda by placing an "X" by each addendum received.

Addendum No. 1 _____

Addendum No. 2 _____

Addendum No. 3 _____

Addendum No. 4 _____

Addendum No. 5 _____

Addendum No. 6 _____

Addendum No. 7 _____

Addendum No. 8 _____

If an addendum or addenda have been issued by the CITY and is not noted above as being received by the Bidder, the Bid Proposal may be rejected.

REFERENCES

[Work similar in scope magnitude and degree of difficulty completed by Contractor within the past three (3) years.]

1. Name (Firm/Agency): _____
Address: _____
Contact Person: _____ Telephone No. _____
Title of Project: _____
Project Location: _____
Date of Completion: _____ Contract Amount: \$ _____

2. Name (Firm/Agency): _____
Address: _____
Contact Person: _____ Telephone No. _____
Title of Project: _____
Project Location: _____
Date of Completion: _____ Contract Amount: \$ _____

3. Name (Firm/Agency): _____
Address: _____
Contact Person: _____ Telephone No. _____
Title of Project: _____
Project Location: _____
Date of Completion: _____ Contract Amount: \$ _____

4. Name (Firm/Agency): _____
Address: _____
Contact Person: _____ Telephone No. _____
Title of Project: _____
Project Location: _____
Date of Completion: _____ Contract Amount: \$ _____

If Contractor has not performed work for the City of La Habra within the last five (5) years, list all work done within said five years (attach additional sheets if necessary). Note if work was done as subcontractor (include only subcontract amount):

| Work Description & Contract Amount | Agency | Date Completed |
|------------------------------------|--------|----------------|
| | | |
| | | |
| | | |
| | | |
| | | |

Contractor's License No.: _____ Class: _____

a. Date first obtained: _____ Expiration: _____

b. Has License ever been suspended or revoked? _____

If yes, described when and why: _____

c. Any current claims against License or Bond? _____

If yes, describe claims: _____

Principals in Company (List all – attach additional sheets if necessary):

| <u>NAME</u> | <u>TITLE</u> | <u>LICENSE NO.</u> (If Applicable) |
|-------------|--------------|---------------------------------------|
| _____ | _____ | _____ |
| _____ | _____ | _____ |
| _____ | _____ | _____ |

DBE BIDDER'S LIST

All bidders/proposers are requested to provide the following information for all DBE and non-DBE contractors or consultants who provided a proposal, bid, quote, or were contacted by the proposed prime. This information is also requested from the proposed prime contractor/consultant and should be submitted with their bid/proposal. The City of La Habra will use this information to maintain and update a "Bidders" List to assist in the overall annual DBE goal-setting process.

| | |
|--|--|
| Firm Name: _____ | Phone: _____ |
| Address: _____ | Fax: _____ |
| Contact Person: _____ | No. of years in business: _____ |
| Is the firm currently certified as a DBE under 49 CFR Part 26: YES: ___ NO: ___ | |
| Type of work/services/materials provided by firm? _____ | |
| _____ | |
| _____ | |
| <hr/> <hr/> What was your firm's Gross Annual receipts for last year? | |
| Less than \$1 Million | |
| Less than \$5 Million | |
| Less than \$10 Million | |
| Less than \$15 Million | |
| More than \$15 Million | |

This form can be duplicated if necessary to report all bidders (DBEs and non-DBEs) information.

VIOLATIONS OF FEDERAL, STATE, OR LOCAL LAWS

1. Has your firm or its officers been assessed any penalties by an agency for noncompliance or violations of Federal, State, or Local labor laws and/or business or licensing regulations within the past five (5) years relating to your construction projects?

Yes/No: _____ Federal/State: _____

If “yes”, identify and describe, (including agency and status):

Have the penalties been paid? Yes/No: _____

2. Does your firm or its officers have any ongoing investigations by any public agency regarding violations of the State Labor Code, California Business and Professions Code or State Licensing Laws?

Yes/No: _____ Code/Laws: _____ Section/Article: _____

If “yes”, identify and describe, (including agency and status):

DISQUALIFICATION OR DEBARMENT

Has your firm, any officer of your firm, or any employee who has a proprietary interest in your firm ever been disqualified, removed, or otherwise prevented from bidding on, performing work on, or completing a federal, state, or local project because of a violation of law or a safety regulation?

Yes/No: _____

If yes, provide the following information (if more than once, use separate sheets):

Date: _____ Entity: _____

Location: _____

Reason: _____

Provide Status and any Supplemental Statement: _____

Has your firm been reinstated by this entity?

Yes/No: _____

LIST OF SUBCONTRACTORS

**MONTE VISTA STREET REHABILITATION PROJECT
FISCAL YEAR 2022-2023
CITY PROJECT NO. 2-R-22**

The bidder shall list below the name and the location of the place of business of each Subcontractor who will perform work or render services to the prime contractor in or about the construction of the work or improvement in excess of one-half of one percent (1/2%) of the prime contractor’s total bid or ten thousand dollars (\$10,000.00) whichever is greater in accordance with the requirements of Section 4100 to 4133 inclusive of the public contracts code.

| <u>Work to be Performed</u> | <u>License Number</u> | <u>Subcontractor and Address of Office, Mill or Shops</u> | <u>Percent of Total Contract</u> | <u>DBE</u> | |
|-----------------------------|-----------------------|---|----------------------------------|------------|-----------|
| | | | | <u>YES</u> | <u>NO</u> |
| | | | | | |
| | | | | | |
| | | | | | |
| | | | | | |
| | | | | | |
| | | | | | |
| | | | | | |
| | | | | | |
| | | | | | |
| | | | | | |
| | | | | | |

Note: Do not list alternative subcontractors for the same work.

Contractor _____

BID SECURITY FORM

(Check to Accompany Bid)

(Note: The following form shall be used in case check accompanies bid.)

Accompanying this proposal is a *(Certified) *(Cashiers) check payable to the order of the City of La Habra, California, hereinafter referred to as "Owner", for

**MONTE VISTA STREET REHABILITATION PROJECT
FISCAL YEAR 2022-2023
CITY PROJECT NO. 2-R-22**

In the amount of \$ _____ Dollars, this amount being ten percent (10%) of the total amount of the bid. The proceeds of this check shall become the property of said Owner provided this proposal shall be accepted by the said Owner through action if its legally constituted contracting authorities and the undersigned shall fail to execute a contract and furnish the required Performance and Payment Bonds and proof of insurance coverage within the stipulated time; otherwise, the check shall be returned to the undersigned. The proceeds of this check shall also become the property of the Owner if the undersigned shall withdraw his bid within the period of forty-five (45) days after the date set for the opening thereof unless otherwise required by law and notwithstanding the award of the Contract to another bidder.

Bidder

*Delete the inapplicable word.

NOTE: If the bidder desires to use a bond instead of a check, the Bid Bond form on the following pages shall be executed. The sum of this bond shall be not less than ten percent (10%) of the total amount of the bid.

BID BOND

KNOW ALL MEN BY THESE PRESENTS:

That we _____ as principal and _____ as surety, are held and firmly bound unto the City of La Habra, California hereinafter referred to as "Owner", in the sum of _____ Dollars (§ _____) to be paid to the said Owner, its successors and assigns for which payment well and truly to be made we bind ourselves, our heirs, executors, administrators, successors and assigns, jointly and severally, firmly by these presents.

THE CONDITION OF THIS OBLIGATION IS SUCH that if the certain proposal of the above bounden for the construction of Street Improvements as specifically set forth in documents entitled:

**MONTE VISTA STREET REHABILITATION PROJECT
FISCAL YEAR 2022-2023
CITY PROJECT NO. 2-R-22**

all in accordance with the specifications and drawings on file at the offices of the City Clerk of the City of La Habra, California and is not withdrawn within the period of sixty (60) days after the date set for the opening of bids unless otherwise required by law and notwithstanding the award of the Contract to another bidder and that if said proposal is accepted by the Owner through action of its legally constituted contracting authorities and if the above bounden his heirs, executors, administrators, successors and assigns shall duly enter into and execute a contract for such construction and shall execute and deliver the required Performance and Payment Bonds and proof of insurance coverage within ten (10) days (not including Saturdays, Sundays and Holidays) after the date of notification by and from the said Owner that the said contract is ready for execution, then this obligation shall become null and void; otherwise, it shall be and remain in full force and virtue.

IN WITNESS WHEREOF, we hereunto set hands and seal this _____

day of _____, 2024.

BIDDER

NOTE: The standard printed bond form of any bonding company acceptable to the Owner may be used in lieu of the foregoing approved sample bond form provided the security stipulations protecting the Owner are not in any way reduced by use of the Surety Company's printed standard form.

NON-COLLUSION AFFIDAVIT
FOR

MONTE VISTA STREET REHABILITATION PROJECT
FISCAL YEAR 2022-2023
CITY PROJECT NO. 2-R-22

(TO BE EXECUTED BY EACH AWARDEE OF A PRINCIPAL CONTRACT)

STATE OF CALIFORNIA)
) SS.
)

_____, being first duly sworn,
deposes and says that he is _____
(sole owner, partner, president, secretary, etc.)

of _____

The party making the foregoing bid; that such bid is not made in the interest of or on behalf of any undisclosed person, partnership, company, association, organization or corporation; that such bid is genuine and not collusive or sham: that said bidder has not directly or indirectly induced or solicited any other bidder to put in a false or sham bid, and has not directly or indirectly colluded, conspired, connived, or agreed with any bidder or anyone else to put in a sham bid, nor that anyone shall refrain from bidding; that said bidder has not in any manner directly or indirectly sought by agreement, communication or conference with anyone to fix the bid price of said bidder or of any other bidder, nor to fix any overhead, profit cost element of such bid price nor of that of any other bidder nor to secure any advantage against the public body awarding the contract or anyone interested in the proposed contract; that all statements contained in such bid are true; and, further, that said bidder has not directly or indirectly, submitted his bid price or any breakdown thereof, nor the contents thereof, nor divulged information or data relative thereto, nor paid and will not pay any fee in connection therewith to any corporation, partnership, company, association, organization, bid depository, nor to any member of agent thereof nor to any other individual except to such person or persons as have a partnership or other financial interest with said bidder in his general business.

Signed: _____

Title: _____

Subscribed and sworn to before me

This _____ day of _____, 2024

SEAL OF NOTARY PUBLIC

WORKER'S COMPENSATION CERTIFICATE

(AS REQUIRED BY SECTION 1861
OF THE CALIFORNIA LABOR CODE)

I am aware of the provisions of Section 3700 of the California Labor Code, which require every employer to be insured against liability for worker's compensation, or to undertake self-insurance in accordance with the provisions of said Code, and I will comply with such provisions before commencing the performance of the Work of this Contract.

Contractor _____

By _____

Title _____

Public Contract Code Section 10285.1 Statement

In conformance with Public Contract Code Section 10285.1 (Chapter 376, Stats. 1985), the bidder hereby declares under penalty of perjury under the laws of the State of California that the bidder **has** ____, **has not** ____ been convicted within the preceding three years of any offenses referred to in that section, including any charge of fraud, bribery, collusion, conspiracy, or any other act in violation of any state or Federal antitrust law in connection with the bidding upon, award of, or performance of, any public works contract, as defined in Public Contract Code Section 1101, with any public entity, as defined in Public Contract Code Section 1100, including the Regents of the University of California or the Trustees of the California State University. The term "bidder" is understood to include any partner, member, officer, director, responsible managing officer, or responsible managing employee thereof, as referred to in Section 10285.1.

Note: The bidder must place a check mark after "has" or "has not" in one of the blank spaces provided. The above Statement is part of the Proposal. Signing this Proposal on the signature portion thereof shall also constitute signature of this Statement. Bidders are cautioned that making a false certification may subject the certifier to criminal prosecution.

Public Contract Code Section 10162 Questionnaire

In conformance with Public Contract Code Section 10162, the Bidder shall complete, under penalty of perjury, the following questionnaire:

Has the bidder, any officer of the bidder, or any employee of the bidder who has a proprietary interest in the bidder, ever been disqualified, removed, or otherwise prevented from bidding on, or completing a federal, state, or local government project because of a violation of law or a safety regulation?

Yes _____ No _____

If the answer is yes, explain the circumstances in the following space.

Public Contract Code Section 10232 Statement

In conformance with Public Contract Code Section 10232, the Contractor, hereby states under penalty of perjury, that no more than one final unappealable finding of contempt of court by a federal court has been issued against the Contractor within the immediately preceding two year period because of the Contractor's failure to comply with an order of a federal court which orders the Contractor to comply with an order of the National Labor Relations Board.

Note: The above Statement and Questionnaire are part of the Proposal. Signing this Proposal on the signature portion thereof shall also constitute signature of this Statement and Questionnaire.

Bidders are cautioned that making a false certification may subject the certifier to criminal prosecution.

SECTION E
SAMPLE AGREEMENT

**CITY OF LA HABRA
PUBLIC WORKS AGREEMENT FOR
MONTE VISTA STREET REHABILITATION PROJECT
FISCAL YEAR 2022-2023, CITY PROJECT NO. 2-R-22**

THIS AGREEMENT (herein "Agreement"), is made and entered into this _____ day of _____, 2024 and between the **CITY OF LA HABRA**, a municipal corporation (herein "City") and _____ (herein "Contractor"). The parties hereto agree as follows:

WITNESSETH:

A. WHEREAS, City requires the construction of roadway improvements as set forth more fully in this Agreement.

B. WHEREAS, Contractor represents to City that Contractor is qualified to perform said work and has submitted a proposal to City for the same.

C. WHEREAS, City desires to have Contractor perform said services on the terms and conditions set forth herein.

D. WHEREAS, no official or employee of City has a financial interest, within the provisions of Sections 1090-1092 of the California Government Code, in the subject matter of this Agreement.

NOW, THEREFORE, for and in consideration of the mutual covenants and conditions contained herein and for good and valuable consideration, the receipt and sufficiency of which is acknowledged by both parties, City and Contractor hereby agree as follows:

1.0 DEFINITIONS

1.1 Definitions. As used in this Agreement, the following definitions shall be applicable:

- (a) Contractor. Contractor shall mean _____, a California corporation located at _____.
- (b) City. City shall mean the City of La Habra, a Municipal Corporation and General Law City, located at 110 E. La Habra Blvd, La Habra, California 90631.
- (c) City Council. City Council shall mean the City Council of the City of La Habra.
- (d) Contract Officer shall mean the person designated by the City Administrator or City Engineer of City and shall have the duties set forth in Section 5.2.
- (e) Services. Services shall mean the services to be performed by the Contractor pursuant to this Agreement.
- (f) Satisfactory. Satisfactory shall mean satisfactory to the City Administrator or his/her designee.

2.0 SERVICES OF CONTRACTOR

2.1 Scope of Services. In compliance with all terms and conditions of this Agreement, the Contractor shall provide those services specified in the "Scope of Services" attached hereto as Exhibit "A" and incorporated herein by this reference, which services may be referred to herein as the "services" or "work" hereunder. As a material inducement to the City entering into this Agreement, Contractor represents and warrants that Contractor is a provider of first class work and services and Contractor is experienced in performing the work and services contemplated herein and, in light of such status and experience, Contractor covenants that it shall follow the highest professional standards in performing the work and services required hereunder and that all materials will be of good quality, fit for the purpose intended.

2.2 Documents Included in Contract. This contract consists of this Agreement and any Exhibits, which are incorporated herein by this reference. In the event of an inconsistency, the terms of this Agreement shall govern.

2.3 Compliance with Law. All services rendered hereunder shall be provided in accordance with all ordinances, resolutions, statutes, rules, and regulations of the City and any Federal, State or local governmental agency having jurisdiction in effect at the time service is rendered, including but not limited to, the claims procedure set forth in Public Contract Code Section 9204, a summary of which is attached to this agreement as Exhibit "D."

2.4 Licenses, Permits, Fees and Assessments. Contractor shall obtain at its sole cost and expense such licenses, permits and approvals as may be required by law for the performance of the services required by this Agreement, including registration with the Department of Industrial Relations of the State of California as required by Labor Code Section 1725.5 before commencing performance under this Agreement. Contractor shall have the sole obligation to pay for any fees, assessments and taxes, plus applicable penalties and interest, which may be imposed by law and arise from or are necessary for the Contractor's performance of the services required by this Agreement, and shall indemnify, defend and hold harmless City against any such fees, assessments, taxes penalties or interest levied, assessed or imposed against City hereunder. Contractor shall be responsible for all subcontractors' compliance with this Section 2.4.

2.5 Familiarity with Work. By executing this Contract, Contractor warrants that Contractor (a) has thoroughly investigated and considered the scope of services to be performed, (b) has carefully considered how the services should be performed, and (c) fully understands the facilities, difficulties and restrictions attending performance of the services under this Agreement. If the services involve work upon any site, Contractor warrants that Contractor has or will investigate the site and is or will be fully acquainted with the conditions there existing, prior to commencement of services hereunder. Should Contractor discover any latent or unknown conditions, which will materially affect the performance of the services hereunder, Contractor shall immediately inform the City of such fact and shall not proceed except at Contractor's risk until written instructions are received from the Contract Officer.

2.6 Standard of Performance. Contractor, its subcontractors and their employees, in the performance of Contractor's work under this Agreement shall be responsible for exercising the degree of skill and care required by customarily accepted good professional practices and procedures used in the Contractor's field.

Any costs for failure to meet the foregoing standard or to correct otherwise defective work that requires re-performance of the work, shall be borne in total by the Contractor and not by the City. The failure of a

project to achieve the performance goals and objectives stated in this Agreement is not a basis for requesting re-performance unless the work conducted by Contractor and/or its subcontractors is deemed by the City to have failed the foregoing standard of performance.

In the event Contractor fails to perform in accordance with the above standard:

1. Contractor will re-perform, at its own expense, any task which was not performed to the reasonable satisfaction of City. Any work re-performed pursuant to this paragraph shall be completed within the time limitations originally set forth for the specific task involved. Contractor shall work any overtime required to meet the deadline for the task at no additional cost to the City;
2. The City shall provide a new schedule for the re-performance of any task pursuant to this paragraph in the event that re-performance of a task within the original time limitations is not feasible; and
3. The City shall have the option to direct Contractor not to re-perform any task which was not performed to the reasonable satisfaction of the City Project Manager pursuant to application of (1) and (2) above. In the event the City directs Contractor not to re-perform a task, the City shall negotiate a reasonable settlement for satisfactory work performed. No previous payment shall be considered a waiver of the City's right to reimbursement.

Nothing contained in this section is intended to limit any of the rights or remedies which the City may have under law.

2.7 Care of Work. The Contractor shall adopt reasonable methods during the life of the Agreement to furnish continuous protection to the work, and the equipment, materials, papers, documents, plans, studies and/or other components thereof to prevent losses or damages, and shall be responsible for all such damages, to persons or property, until acceptance of the work by City, except such losses or damages as may be caused by City's own negligence.

2.8 Further Responsibilities of Parties. Both parties agree to use reasonable care and diligence to perform their respective obligations under this Agreement. Both parties agree to act in good faith to execute all instruments, prepare all documents and take all actions as may be reasonably necessary to carry out the purposes of this Agreement. Unless hereafter specified, neither party shall be responsible for the service of the other. Contractor shall require all subcontractors to comply with the provisions of this agreement.

2.9 Additional Services. City shall have the right at any time during the performance of the services, without invalidating this Agreement, to order extra work beyond that specified in the Scope of Services or make changes by altering, adding to or deducting from said work. No such extra work may be undertaken unless a written change order is first given by the Contract Officer to the Contractor, incorporating therein any adjustment in (i) the Contract Sum as set forth in Section 3.1, and/or (ii) the time to perform this Agreement, which said adjustments are subject to the written approval of the Contractor. Any increase in compensation of twenty five percent (25%) or less of the Contract Sum, or in the time to perform of one hundred eighty (180) days or less may be approved by the Contract Officer. Any increases, taken either separately or cumulatively, that result in the Contract Sum exceeding \$25,000 must be approved by the City Council. It is expressly understood by Contractor that the provisions of this Section shall not apply to services specifically set forth in the Scope of Services or reasonably contemplated therein. Contractor hereby acknowledges that it accepts the risk that the services to be provided pursuant to the Scope of Services may be more costly or time consuming than Contractor anticipates and that Contractor shall not be entitled to additional compensation therefore.

2.10 Prevailing Wage Laws. Contractor represents and warrants that it is registered with the Department of Industrial Relations pursuant to SB 854 and Labor Code 1725.5. Contractor shall ensure that its subcontractors comply with said requirements. In accordance with Labor Code Section 1770 et seq., the Director of the Department of Industrial Relations of the State of California has ascertained a general prevailing rate of wages, which is the minimum amount, which shall be paid to all workers employed to perform the work pursuant to this Agreement. A copy of the general prevailing wage rate determination is on file in the Office of the City Clerk and is hereby incorporated by reference into this Agreement. In accordance with the provisions of Labor Code Section 1810 et seq., eight (8) hours is the legal working day. Contractor must forfeit to the City Twenty Five Dollars (\$25.00) a day for each worker who works in excess of the minimum working hours when Contractor does not pay overtime. Contractor is required to post a copy of such wage rates at all times at the contract site. The statutory penalties for failure to pay prevailing wage or to comply with State wage and hour laws will be enforced. Contractor also shall comply with State law requirements to maintain payroll records and shall provide for certified records and inspection of records as required by California Labor Code Section 1770 et. seq., including Section 1776. Contractor shall comply with all statutory requirements relating to the employment of apprentices.

3.0 COMPENSATION

3.1 Contract Sum. For the services rendered pursuant to this Agreement, the Contractor shall be compensated as specified herein, but not exceeding the maximum contract amount of ____ Dollars (\$____) (herein "Contract Sum"), except as provided in Section 2.9. The Contract Sum shall include the attendance of Contractor at all project meetings reasonably deemed necessary by the City; Contractor shall not be entitled to any additional compensation for attending said meetings.

3.2 Progress Payments. Prior to the first day of the month, during the progress of the work, commencing on the day and month specified in the Agreement, Contractor shall submit to the Contract Officer a complete itemized statement of all labor and materials incorporated into the work during the preceding month and the portion of the contract sum applicable thereto. Upon approval in writing by the Contract Officer, payment shall be made in thirty (30) days. City shall pay Contractor a sum based upon ninety-five percent (95%) of the contract price apportionment of the labor and materials incorporated into the work under the contract during the month covered by said statement. The remaining five percent (5%) thereof shall be retained as performance security. Refer to Section 8.4 of this Agreement for retention of funds.

4.0 PERFORMANCE SCHEDULE

4.1 Time of Essence. Time is of the essence in the performance of this Agreement.

4.2 Schedule of Performance. Contractor shall commence the services pursuant to this Agreement upon receipt of a written notice to proceed and shall perform all services within the time period(s) established in Exhibit "A", and incorporated herein by this reference. When requested by the Contractor, extensions to the time period(s) specified in the Scope of Services may be approved in writing by the Contract Officer.

4.3 Force Majeure. The time period(s) specified in the Scope of Services for performance of the services rendered pursuant to this Agreement shall be extended because of any delays due to unforeseeable causes beyond the control and without the fault or negligence of the Contractor, including, but not restricted to, acts of God or of the public enemy, unusually severe weather, fires, earthquakes, floods, epidemics, quarantine restrictions, riots, strikes, freight embargoes, wars, litigation, and/or acts of any governmental agency, including the City, if the Contractor shall within ten (10) days of the commencement of such delay notify the Contract

Officer in writing of the causes for the delay. The Contract Officer shall ascertain the facts and the extent of delay, and extend the time for performing the services for the period of the enforced delay when and if in the judgment of the Contract Officer such delay is justified. The Contract Officer's determination shall be final and conclusive upon the parties to this Agreement.

4.4 Term. Unless earlier terminated in accordance with Section 8.9 of this Agreement, this Agreement shall continue in full force and effect until final approval and acceptance of the project by the Contract Officer. Notwithstanding the foregoing, this Agreement shall terminate no later than June 30, 2025, unless the parties mutually agree in writing to extend the term.

5.0 COORDINATION OF WORK

5.1 Representative of Contractor. The following principals of Contractor are hereby designated as being the principals and representatives of Contractor authorized to act in its behalf with respect to the work specified herein and make all decisions in connection therewith:

It is expressly understood that the experience, knowledge, capability and reputation of the foregoing principals were a substantial inducement for City to enter into this Agreement. Therefore, the foregoing principals shall be responsible during the term of this Agreement for directing all activities of Contractor and devoting sufficient time to personally supervise the services hereunder. For purposes of this Agreement, the foregoing principals may not be replaced nor may their responsibilities be substantially reduced by Contractor without the express written approval of City.

5.2 Contract Officer. The Contract Officer shall be such person as may be designated by the City Administrator or City Engineer of City. It shall be the Contractor's responsibility to assure that the Contract Officer is kept informed of the progress of the performance of the services and the Contractor shall refer any decisions that must be made by City to the Contract Officer. Unless otherwise specified herein, any approval of City required hereunder shall mean the approval of the Contract Officer. The Contract Officer shall have authority to sign all documents on behalf of the City required hereunder to carry out the terms of this Agreement.

5.3 Prohibition Against Assignment. The experience, knowledge, capability and reputation of Contractor, its principals and employees were a substantial inducement for the City to enter into this Agreement. Neither this Agreement nor any interest herein may be transferred, assigned, conveyed, hypothecated or encumbered voluntarily or by operation of law, whether for the benefit of creditors or otherwise, without the prior written approval of City. Transfers restricted hereunder shall include the transfer to any person or group of persons acting in concert of more than twenty five percent (25%) of the present ownership and/or control of Contractor, taking all transfers into account on a cumulative basis. In the event of any such unapproved transfer, including any bankruptcy proceeding, this Agreement shall be void. No approved transfer shall release the Contractor or any surety of Contractor of any liability hereunder without the express consent of City.

5.4 Independent Contractor. Neither the City nor any of its employees shall have any control over the manner, mode or means by which Contractor, its subcontractors, agents or employees, performs the services required herein, except as otherwise set forth herein. City shall have no voice in the selection, discharge, supervision or control of Contractor's employees, subcontractors, servants, representatives or agents, or in fixing their number, compensation or hours of service. Contractor shall perform all services

required herein as an independent contractor of City and shall remain at all times as to City a wholly independent contractor with only such obligations as are consistent with that role. Contractor shall not at any time or in any manner represent that it or any of its subcontractors, agents or employees are agents or employees of City. City shall not in any way or for any purpose become or be deemed to be a partner of Contractor in its business or otherwise or a joint venture or a member of any joint enterprise with Contractor.

5.5 Identity of Persons Performing Work. Contractor represents that it employs or will employ at its own expense all personnel required for the satisfactory performance of any and all tasks and services set forth herein. Contractor represents that the tasks and services required herein will be performed by Contractor or under its direct supervision, and that all personnel engaged in such work shall be fully qualified and shall be authorized and permitted under applicable State and local law to perform such tasks and services.

5.6 Utility Relocation. City is responsible for removal, relocation, or protection of existing main or trunkline utilities to the extent such utilities were not identified in the invitation for bids or specifications. City shall reimburse contractor for any costs incurred in locating, repairing damage not caused by contractor and removing or relocating such unidentified utility facilities, including equipment idled during such work. Contractor shall not be assessed liquidated damages for delay arising from the removal or relocation of such unidentified utility facilities.

5.7 Trenches or Excavations. Pursuant to California Public Contract Code Section 7104, in the event the work included in this Agreement requires excavations more than four (4) feet in depth, the following shall apply.

- (a) Contractor shall promptly, and before the following conditions are disturbed, notify City, in writing, of any: (1) material that Contractor believes may be material that is hazardous waste, as defined in Section 25117 of the Health and Safety Code, that is required to be removed to a Class I, Class II, or Class III disposal site in accordance with provisions of existing law; (2) Subsurface or latent physical conditions at the site different from those indicated; or (3) Unknown physical conditions at the site of any unusual nature, different materially from those ordinarily encountered and generally recognized as inherent in work of the character provided for in the contract.
- (b) City shall promptly investigate the conditions, and if it finds that the conditions do materially so differ, or do involve hazardous waste, and cause a decrease or increase in Contractor's cost of, or the time required for, performance of any part of the work shall issue a change order per Section 2.9 of this Agreement.
- (c) That, in the event that a dispute arises between City and Contractor whether the conditions materially differ, or involve hazardous waste, or cause a decrease or increase in Contractor's cost of, or time required for, performance of any part of the work, Contractor shall not be excused from any scheduled completion date provided for by the contract, but shall proceed with all work to be performed under the contract. Contractor shall retain any and all rights provided either by contract or by law, which pertain to the resolution of disputes and protests between the contracting parties.

6.0 INSURANCE, INDEMNIFICATION AND BONDS

6.1 Insurance. The Contractor and all subcontractors, if any, shall procure and maintain, at its sole cost and expense, in a form and content satisfactory to City, during the entire term of this Agreement including any extension thereof, insurance as set forth in Exhibit "B" attached hereto and incorporated herein by this reference.

Conditions:

In accordance with Public Contract Code Section 20170, the insurance of surety companies who provide or issue the policy shall have been admitted to do business in the State of California with a credit rating of A- or better.

This insurance shall not be canceled, limited in scope or coverage or non-renewed until after thirty (30) days prior written notice has been given to the Public Works Director, City of La Habra, 110 E. La Habra Blvd., La Habra, California 90631.

Any insurance maintained by the City of La Habra shall apply in excess of and not combined with insurance provided by this policy.

The City of La Habra, its officers, employees, representatives, attorneys, and volunteers shall be named as additional named insureds.

Prior to commencement of any work under this contract, Contractor shall deliver to the City insurance endorsements confirming the existence of the insurance required by this contract, and including the applicable clauses referenced above.

Such endorsements shall be signed by an authorized representative of the insurance company and shall include the signator's company affiliation and title. Should it be deemed necessary by the City, it shall be Contractor's responsibility to see that the City receives documentation, acceptable to the City, which sustains that the individual signing said endorsements is indeed authorized to do so by the insurance company.

If the Contractor fails to maintain the aforementioned insurance, or secure and maintain the aforementioned endorsement, the City may obtain such insurance, and deduct and retain the amount of the premiums for such insurance from any sums due under the agreement. However, procuring of said insurance by the City is an alternative to other remedies the City may have, and is not the exclusive remedy for failure of Contractor to maintain said insurance or secure said endorsement. In addition to any other remedies the City may have upon Contractor's failure to provide and maintain any insurance or policy endorsements to the extent and within the time herein required, the City shall have the right to order Contractor to stop work hereunder, and/or withhold any payment(s) which became due to Contractor hereunder until Contractor demonstrates compliance with the requirements hereof.

Nothing herein contained shall be construed as limiting in any way the extent to which Contractor may be held responsible for payments of damages to persons or property resulting from Contractor's or its subcontractor's performance of the work covered under this agreement.

Each contract between the Contractor and any subcontractor shall require the subcontractor to maintain the same policies of insurance that the Contractor is required to maintain pursuant to this Section 6.1.

6.2 Certificates of Insurance. Contractor shall provide to City certificates of insurance showing the insurance coverages and required endorsements described above, in a form and content approved by City, prior to performing any services under this Agreement. The certificates of insurance and endorsements shall be attached to this Agreement as Exhibit "C", and are incorporated herein by this reference.

6.3 Indemnification. Contractor shall defend, indemnify, hold free and harmless the City of La Habra, its elected and appointed officials, officers, agents and employees, at Contractor's sole expense, from and against any and all actions, suits, claims, damages to persons or property, losses, costs, penalties, obligations, errors, omissions or liabilities, (herein "claims or liabilities") that may be asserted or claimed by any person, firm or entity arising or alleged to arise out of or in connection with the performance of the work, operations or activities of Contractor, its agents, employees, subcontractors, or invitees, provided for herein, or arising or alleged to arise from the negligent acts or omissions of Contractor hereunder, or arising or alleged to arise from Contractor's performance of or failure to perform any term, provision, covenant or condition of this Agreement.

- (a) Contractor will defend any action or actions filed in connection with any of said claims or liabilities and will pay all costs and expenses, including legal costs and attorneys' fees incurred in connection therewith.
- (b) Contractor will promptly pay any judgment rendered against the City, its officers, agents or employees for any such claims or liabilities arising or alleged to arise out of or in connection with Contractor's (or its agents', employees', subcontractors' or invitees') negligent performance of or failure to perform such work, operations or activities hereunder; and Contractor agrees to save and hold the City, its officers, agents, and employees harmless therefrom.
- (c) In the event the City, its officers, agents or employees is made a party to any action or proceeding filed or prosecuted against Contractor for such damages or other claims arising or alleged to arise out of or in connection with the performance of or failure to perform the work, operation or activities of Contractor hereunder, Contractor shall pay to the City, its officers, agents or employees, any and all costs and expenses incurred by the City, its officers, agents or employees in such action or proceeding, including but not limited to, legal costs and attorneys' fees for counsel selected by City.
- (d) Contractor's duty to defend and indemnify as set out in this Section 6.3 shall include any claims, liabilities, obligations, losses, demands, actions, penalties, suits, costs, expenses or damages or injury to persons or property arising or alleged to arise from, in connection with, as a consequence of or pursuant to any state or federal law or regulation regarding hazardous substances, including but not limited to the Federal Insecticide, Fungicide and Rodenticide Act ("FIFRA"), Comprehensive Environmental Response, Compensation and Liability Act of 1980 ("CERCLA"), Resource Conservation and Recovery Act of 1976 ("RCRA"), the Hazardous and Solid Waste Amendments of 1984, the Hazardous Material Transportation Act, the Toxic Substances control Act, the Clean Air Act, the Clean Water Act, the California Hazardous Substance Account Act, the California Hazardous Waste Control Law or the Porter-Cologne Water Quality Control Act, as any of those statutes may be amended from time to time.

Notwithstanding the foregoing, Contractor shall not be liable for the defense or indemnification of the City for claims, actions, complaints or suits arising out of the sole active negligence or willful misconduct of the City.

The Contractor's indemnification obligations pursuant to this Section 6.3 shall survive the termination of this Agreement. Contractor shall require the same indemnification from all subcontractors.

6.4 Labor and Materials and Performance Bonds. Concurrently with execution of this Agreement, Contractor shall deliver to City a labor and materials bond and a performance bond each in the sum of the amount of this Agreement, in the forms provided by the City Clerk, which secures the faithful performance of this Agreement. The bonds shall contain the original notarized signature of an authorized officer of the surety and affixed thereto shall be a certified and current copy of his power of attorney. The bonds shall be unconditional and remain in force during the entire term of the Agreement and shall be null and void only if the Contractor promptly and faithfully performs all terms and conditions of this Agreement.

6.5 Sufficiency of Insurer or Surety. Insurance required by this Agreement shall be satisfactory only if issued by companies qualified to do business in California, rated "A" or better in the most recent edition of Best Rating Guide, The Key Rating Guide or in the Federal Register, and only if they are of a financial category Class VII or better, unless such requirements are waived by the Risk Manager of the City due to unique circumstances.

6.6 Substitution of Securities. Pursuant to California Public Contract Code Section 22300, substitution of eligible equivalent securities for any monies withheld to ensure performance under the contract for the work to be performed will be permitted at the request and expense of the successful bidder.

7.0 RECORDS AND REPORTS

7.1 Reports. Contractor shall periodically prepare and submit to the Contract Officer such reports concerning the performance of the services required by this Agreement as the Contract Officer shall require. Contractor hereby acknowledges that the City is greatly concerned about the cost of work and services to be performed pursuant to this Agreement. For this reason, Contractor agrees that if Contractor becomes aware of any facts, circumstances, techniques, or events that may or will materially increase or decrease the cost of the work or services contemplated herein or, if Contractor is providing design services, the cost of the project being designed, Contractor shall promptly notify the Contract Officer of said fact, circumstance, technique or event and the estimated increased or decreased cost related thereto and, if Contractor is providing design services, the estimated increased or decreased cost estimate for the project being designed.

7.2 Records. Contractor shall keep, and require subcontractors to keep, such books and records (including but not limited to payroll records as required herein) as shall be necessary to perform the services required by this Agreement and enable the Contract Officer to evaluate the performance of such services. The Contract Officer shall have full and free access to such books and records at all times during normal business hours of City, including the right to inspect, copy, audit and make records and transcripts from such records. Such records shall be maintained for a period of three (3) years following completion of the services hereunder, and the City shall have access to such records in the event any audit is required.

7.3 Ownership of Documents. All drawings, specifications, reports, records, documents and other materials prepared by Contractor, its employees, subcontractors and agents in the performance of this Agreement shall be the property of City and shall be delivered to City upon request of the Contract Officer or upon the termination of this Agreement, and Contractor shall have no claim for further employment or additional compensation as a result of the exercise by City of its full rights of ownership of the documents and materials hereunder. Contractor may retain copies of such documents for its own use. Contractor shall have an unrestricted right to use the concepts embodied therein. All subcontractors shall

provide for assignment to City of any documents or materials prepared by them, and in the event Contractor fails to secure such assignment, Contractor shall indemnify City for all damages resulting therefrom.

7.4 Public Records Act Disclosure. Contractor has been advised and is aware that this Agreement and all reports, documents, information and data, including, but not limited to, computer tapes, discs or files furnished or prepared by Contractor, or any of its subcontractors, pursuant to this Agreement and provided to City may be subject to public disclosure as required by the California Public Records Act (California Government Code Section 6250 *et seq.*). Exceptions to public disclosure may be those documents or information that qualify as trade secrets, as that term is defined in the California Government Code Section 6254.7, and of which Contractor informs City of such trade secret. The City will endeavor to maintain as confidential all information obtained by it that is designated as a trade secret. The City shall not, in any way, be liable or responsible for the disclosure of any trade secret including, without limitation, those records so marked if disclosure is deemed to be required by law or by order of the Court.

8.0 GENERAL PROVISIONS

8.1 Governing Law. This Agreement shall be construed and interpreted both as to validity and to performance of the parties in accordance with the laws of the State of California. Legal actions concerning any dispute, claim or matter arising out of or in relation to this Agreement shall be instituted in the Superior Court of the County of Orange, State of California, or any other appropriate court in such county, and Contractor covenants and agrees to submit to the personal jurisdiction of such court in the event of such action.

8.2 Representatives. The City Administrator or his or her designee shall be the representative of City for purposes of this Agreement and may issue all consents, approvals, directives and agreements on behalf of the City, called for by this Agreement, except as otherwise expressly provided in this Agreement.

The Principal set forth in Section 5.1 above shall be the representative for Contractor for purposes of this Agreement, and shall be authorized to issue all consents, approvals, directives and agreements on behalf of Contractor called for by this Agreement, except as otherwise expressly provided in this Agreement.

8.3 Disputes. In the event either party fails to perform its obligations hereunder, the nondefaulting party shall provide the defaulting party written notice of such default. The defaulting party shall have ten (10) days to cure the default; provided that, if the default is not reasonably susceptible to being cured within said ten (10) day period, the defaulting party shall have a reasonable time to cure the default, not to exceed a maximum of thirty (30) days, so long as the defaulting party commences to cure such default within ten (10) days of service of such notice and diligently prosecutes the cure to completion; provided further that if the default is an immediate danger to the health, safety and general welfare, the defaulting party shall take such immediate action as may be necessary. Notwithstanding the foregoing, the nondefaulting party may, in its sole and absolute discretion, grant a longer cure period. Should the defaulting party fail to cure the default within the time period provided in this Section, the nondefaulting party shall have the right, in addition to any other rights the nondefaulting party may have at law or in equity, to terminate this Agreement. Compliance with the provisions of this Section 8.3 shall be a condition precedent to bringing any legal action, and such compliance shall not be a waiver of any party's right to take legal action in the event that the dispute is not cured.

8.4 Retention of Funds. Progress payments shall be made in accordance with the provisions of Section 3.2 of this Agreement. In accordance with said section, City shall pay Contractor a sum based upon ninety-five percent (95%) of the contract price apportionment of the labor and materials incorporated into

the work under the contract during the month covered by said statement. The remaining five percent (5%) thereof shall be retained as performance security to be paid to the Contractor within sixty (60) days after final acceptance of the work by the City Council, after Contractor shall have furnished City with a release of all undisputed contract amounts if required by City. In the event there are any claims specifically excluded by Contractor from the operation of the release, the City may retain proceeds (per Public Contract Code 7107) of up to 150% of the amount in dispute. City's failure to deduct or withhold shall not affect Contractor's obligations hereunder.

8.5 Waiver. No delay or omission in the exercise of any right or remedy by a nondefaulting party on any default shall impair such right or remedy or be construed as a waiver. A party's consent to or approval of any act by the other party requiring the party's consent or approval shall not be deemed to waive or render unnecessary the other party's consent to or approval of any subsequent act. Any waiver by either party of any default must be in writing and shall not be a waiver of any other default concerning the same or any other provision of this Agreement.

8.6 Rights and Remedies. Rights and Remedies are cumulative except with respect to rights and remedies expressly declared to be exclusive in this Agreement, the rights and remedies of the parties are cumulative and the exercise by either party of one or more of such rights or remedies shall not preclude the exercise by it, at the same or different times, of any other rights or remedies for the same default or any other default by the other party.

8.7 Legal Action. In addition to any other rights or remedies, either party may take legal action, in law or in equity, to cure, correct or remedy any default, to recover damages for any default, to compel specific performance of this Agreement, to obtain declaratory or injunctive relief, or to obtain any other remedy consistent with the purposes of this Agreement.

8.8 Liquidated Damages. Since the determination of actual damages for any delay in performance of this Agreement would be extremely difficult or impractical to determine in the event of a breach of this Agreement, the Contractor and its sureties shall be liable for and shall pay to the City One Thousand Five Hundred Dollars (\$1,500.00) as liquidated damages for each working day of delay in the performance of any service required hereunder, as specified in the Scope of Services (Exhibit A). The City may withhold from any monies payable on account of services performed by the Contractor any accrued liquidated damages.

8.9 Termination for Default of Contractor. If termination is due to the failure of the Contractor to fulfill its obligations under this Agreement, Contractor shall vacate any City owned property which Contractor is permitted to occupy hereunder and City may, after compliance with the provisions of Section 8.3, take over the work and prosecute the same to completion by contract or otherwise, and the Contractor shall be liable to the extent that the total cost for completion of the services required hereunder exceeds the compensation herein stipulated (provided that the City shall use reasonable efforts to mitigate such damages), and City may withhold any payments to the Contractor for the purpose of setoff or partial payment of the amounts owed the City as previously stated.

8.10 Notice. Any notice, demand, request, document, consent, approval, or communication either party desires or is required to give to the other party or any other person shall be in writing and shall be deemed to be given when served personally or deposited in the US Mail, prepaid, first-class mail, return receipt requested, addressed as follows:

To City: City of La Habra
110 E. La Habra Blvd
La Habra, California 90631

Attn.: Albert Mendoza

To Contractor:

8.11 Non-liability of City Officers and Employees. No officer or employee of the City shall be personally liable to the Contractor, or any successor in interest, in the event of any default or breach by the City or for any amount which may become due to the Contractor or to its successor, or for breach of any obligation of the terms of this Agreement.

8.12 Conflict of Interest. The Contractor warrants that it has not paid or given and will not pay or give any third party any money or other consideration for obtaining this Agreement.

Contractor and its officers, employees, associates and subcontractors, if any, will comply with all conflict of interest statutes of the State of California applicable to Contractor's services under this agreement, including, but not limited to, the Political Reform Act (Government Code Sections 81000, *et seq.*) and Government Code Section 1090. During the term of this Agreement, Contractor and its officers, employees, associates and subcontractor shall not, without the prior written approval of the City Representative, perform work for another person or entity for whom Contractor is not currently performing work that would require Contractor or one of its officers, employees, associates or subcontractors to abstain from a decision under this Agreement pursuant to a conflict of interest statute.

8.13 Covenant Against Discrimination. Contractor covenants that, by and for itself, its heirs, executors, assigns, and all persons claiming under or through them, that there shall be no discrimination against or segregation of, any person or group of persons on account of race, color, creed, religion, sex, marital status, national origin, or ancestry in the performance of this Agreement. To the extent required by law, contractor shall take affirmative action to insure that applicants are employed and that employees are treated during employment without regard to their race, color, creed, religion, sex, marital status, national origin, or ancestry.

8.14 Interpretation. The terms of this Agreement shall be construed in accordance with the meaning of the language used and shall not be construed for or against either party by reason of the authorship of this Agreement or any other rule of construction which might otherwise apply.

8.15 Severability. In the event that any one or more of the phrases, sentences, clauses, paragraphs, or sections contained in this Agreement shall be declared invalid or unenforceable by a valid judgment or decree of a court of competent jurisdiction, such invalidity or unenforceability shall not affect any of the remaining phrases, sentences, clauses, paragraphs, or sections of this Agreement which are hereby declared as severable and shall be interpreted to carry out the intent of the parties hereunder unless the invalid provision is so material that its invalidity deprives either party of the basic benefit of their bargain or renders this Agreement meaningless.

8.16 [reserved]

8.17 Unfair Business Practices Claims. In entering into a public works contract or a subcontract to supply goods, services or materials pursuant to a public works contract, the contractor or

subcontractor offers and agrees to assign to the awarding body all rights, title, and interest in and to all causes of action it may have under Section 4 of the Clayton Act (15 U.S.C. Sec. 15) or under the Cartwright Act (Chapter 2, (commencing with Section 16700) of Part 2 of Division 7 of the Business and Professions Code), arising from purchases of goods, services or materials pursuant to the public works contract or the subcontract. This assignment shall be made and become effective at the time the awarding body renders final payment to the contractor without further acknowledgment by the parties. (Sec. 7103.5, California Public Contract Code).

8.18 Corporate Authority. The persons executing this Agreement on behalf of the parties hereto warrant that (i) such party is duly organized and existing, (ii) they are duly authorized to execute and deliver this Agreement on behalf of said party, (iii) by so executing this Agreement, such party is formally bound to the provisions of this Agreement, and (iv) the entering into this Agreement does not violate any provision of any other Agreement to which said party is bound.

8.19 PERS Eligibility Indemnification. In the event that Contractor or any employee, agent, or subcontractor of Contractor providing services under this Agreement claims or is determined by a court of competent jurisdiction or the California Public Employees Retirement System (PERS) to be eligible for enrollment in PERS as an employee of the City, Contractor shall indemnify, defend, and hold harmless City for the payment of any employee and/or employer contributions for PERS benefits on behalf of Contractor or its employees, agents, or subcontractors, as well as for the payment of any penalties and interest on such contributions, which would otherwise be the responsibility of City.

Notwithstanding any other agency, state or federal policy, rule, regulation, law or ordinance to the contrary, Contractor and any of its employees, agents, and subcontractors providing service under this Agreement shall not qualify for or become entitled to, and hereby agree to waive any claims to, any compensation, benefit, or any incident of employment by City, including but not limited to eligibility to enroll in PERS as an employee of City and entitlement to any contribution to be paid by City for employer contribution and/or employee contributions for PERS benefits.

8.20 Cooperation. In the event any claim or action is brought against City relating to Contractor's performance or services rendered under this Agreement, Contractor shall render any reasonable assistance and cooperation which City might require.

8.21 Legal Responsibilities. The Contractor shall keep itself informed of City, State, and Federal laws, ordinances and regulations, which may in any manner affect the performance of its services pursuant to this Agreement. The Contractor shall at all times observe and comply with all such laws, ordinances and regulations. Neither the City, nor its officers, agents, or employees shall be liable at law or in equity as a result of the Contractor's failure to comply with this section.

8.22 Termination for Convenience. The City may terminate this Agreement without cause for convenience of the City upon giving contractor 30 days prior written notice of termination of the Agreement. Upon receipt of the notice of termination the Contractor shall cease all further work pursuant to the Agreement. Upon such termination by the City the Contractor shall not be entitled to any other remedies, claims, actions, profits, or damages except as provided in this paragraph. Upon the receipt of such notice of termination Contractor shall be entitled to the following compensation:

1. The contract value of the work completed to and including the date of receipt of the notice of termination, less the amount of progress payments received by contractor.

2. Actual move-off costs including labor, rental fees, equipment transportation costs, the costs of maintaining on-site construction office for supervising the mover-off.

3. The cost of materials custom made for this Agreement which cannot be used by the Contractor in the normal course of his business, and which have not been paid for by City in progress payments.

4. All costs shall not include any markups as might otherwise be allowed by any plans or specifications which were a part of the Agreement.

The provisions of this paragraph shall supersede any other provision of the Agreement or any provision of any plans, specification, addendums or other documents which are or may become a part of this Agreement. City and Contractor agree that the provisions of this paragraph are a substantive part of the consideration for this Agreement.

8.23 Responsibility for Errors. Contractor shall be responsible for its work and results under this Agreement. Contractor, when requested, shall furnish clarification and/or explanation as may be required by the City's representative, regarding any services rendered under this Agreement at no additional cost to City. In the event that an error or omission attributable to Contractor occurs, then Contractor shall, at no cost to City, provide all necessary design drawings, estimates and other Contractor professional services necessary to rectify and correct the matter to the sole satisfaction of City and to participate in any meeting required with regard to the correction.

8.24 Order of Precedence. In the event of an inconsistency in this Agreement and any of the attached Exhibits, the terms set forth in this Agreement shall prevail. If, and to the extent this Agreement incorporates by reference any provision of any document, such provision shall be deemed a part of this Agreement. Nevertheless, if there is any conflict among the terms and conditions of this Agreement and those of any such provision or provisions so incorporated by reference, this Agreement shall govern over the document referenced.

8.25 Costs. Each party shall bear its own costs and fees incurred in the preparation and negotiation of this Agreement and in the performance of its obligations hereunder except as expressly provided herein.

8.26 No Third Party Beneficiary Rights. This Agreement is entered into for the sole benefit of City and Contractor and no other parties are intended to be direct or incidental beneficiaries of this Agreement and no third party shall have any right in, under or to this Agreement.

8.27 Headings. Paragraphs and subparagraph headings contained in this Agreement are included solely for convenience and are not intended to modify, explain or to be a full or accurate description of the content thereof and shall not in any way affect the meaning or interpretation of this Agreement.

8.28 Construction. The parties have participated jointly in the negotiation and drafting of this Agreement. In the event an ambiguity or question of intent or interpretation arises with respect to this Agreement, this Agreement shall be construed as if drafted jointly by the parties and in accordance with its fair meaning. There shall be no presumption or burden of proof favoring or disfavoring any party by virtue of the authorship of any of the provisions of this Agreement.

8.29 Counterparts. This Agreement may be executed in one or more counterparts, each of which

shall be deemed an original. All counterparts shall be construed together and shall constitute one agreement.

8.30 Funding Source Conditions – Contractor’s Obligation. Contractor acknowledges that the City may be paying for the Project by using funds it receives or will receive from various funding sources in the form of grants and/or subsidies, and the like under certain terms and conditions. Contractor acknowledges and agrees that any failure of the Contractor and/or its subcontractors to perform its obligations under the Contract, including, but not limited to, timely submitting accurate reports and records, that in any way results in the City not meeting the terms and conditions placed on the funds by the funding source, or forfeiting its entitlement to or, otherwise, not receiving, the funds, then the Contractor shall be liable to pay the City for the funds not granted to the City on the Project.

8.31 Entire Agreement. This Agreement constitutes the entire agreement between the parties with respect to any matter referenced herein and supersedes any and all other prior writings and oral negotiations. This Agreement may be modified only in writing, and signed by the parties in interest at the time of such modification. The terms of this Agreement shall prevail over any inconsistent provision in any other contract document appurtenant hereto, including exhibits to this Agreement.

IN WITNESS WHEREOF, the parties have executed and entered into this Agreement as of the date first written above.

CITY OF LA HABRA,
A municipal corporation

Jim Sadro, City Manager

Date: _____

CONTRACTOR

Signature

Date: _____

Name and Title

Social Security or Taxpayer ID Number

ATTEST:

_____, City Clerk

APPROVED AS TO FORM:

Richard D. Jones, City Attorney

Date: _____

(Use of City Bond Form is Required)

**LABOR AND MATERIAL PAYMENT BOND
PUBLIC WORK (CALIFORNIA)**

KNOW ALL MEN BY THESE PRESENT:

WHEREAS, _____, as Principal, has entered into a contract dated _____, with the City of La Habra (Obligee) referred to and made a part hereof to perform the following work, to wit: _____ and all appurtenant work in accordance with PROJECT NO. _____, which requires Principal to file this bond to secure claims made in relation to the project.

NOW THEREFORE, we, _____, as Principal, and _____, a corporation organized under the laws of _____ and duly authorized to transact business in the State of California, as Surety, are held firmly bound unto the City of La Habra, as Obligee, and all sub-contractors, laborers, material persons and other persons employed in the performance of the referenced agreement, in the sum of _____ Dollars (\$ _____ .00), lawful money of the United States of America, for the payment whereof well and truly to be made the Principal and Surety bind themselves, their heirs, executors, administrators, successors, and assigns, jointly and severally, firmly by these presents.

If the above bounden PRINCIPAL, his or its heirs, executors, administrators, successors, assigns, or any of his or its sub-contractors, fails to pay for any materials, provisions, provender, or other supplies, or teams, implements or machinery, used in, upon, for or about the performance of the work contracted to be done, or for any work or labor to persons named in Section 9100 or the Civil Code, thereon of any kind, or for amounts due under the Unemployment Insurance Code with respect to such work or labor deducted, withheld and paid over to the Employment Development Department from the wages of employees of the contractor and sub-contractors pursuant to Section 13020 of the Unemployment Insurance Code, that the SURETY on this bond will pay the same, in an amount not exceeding the sum specified in this bond, AND ALSO, in case suit is brought upon this bond, a reasonable attorney's fee, which shall be awarded by the court to the prevailing party in said suit, said attorney's fee to be taxed as costs in said suit and to be included in the judgment herein rendered.

As part of the obligation secured hereby, the SURETY shall not be exonerated or released from the obligation of the bond by any change, alteration, or modification in or of any contract, plans, specifications, or agreement pertaining or relating to any scheme or work of improvement or pertaining or relating to the furnishing of labor, materials, or equipment therefor, nor by any change or modification of any terms of payment or extension of the time for any payment pertaining or relating to any scheme of work of improvement, nor by any rescission or attempted rescission of the contract, agreement or bond, nor by any conditions precedent or subsequent in the bond attempting to limit the right of recovery of claimants otherwise entitled to recover under

any such contract or agreement, or under the bond, nor, where the bond is given for the benefit of claimants, by any fraud practiced by any person other than the claimant seeking to recover on the bond.

This bond shall inure to the benefit of any and all persons, companies and corporations entitled to file claims under the Civil Code so as to give them a right of action in a suit on this bond.

This bond is executed for the purpose of complying with the laws of the State of California and shall inure to the benefit of any of the persons named in Section 9100 of the Civil Code of the State of California.

IN WITNESS THEREOF, we have hereunto set our hands and seals this _____ day of _____, 20__.

(Corporate Seal)

Principal

By _____

Title

(Corporate Seal)

Principal

By _____

Title

APPROVED AS TO FORM:
/s/ Richard D. Jones
City Attorney

FAITHFUL PERFORMANCE BOND

KNOW ALL MEN BY THESE PRESENTS:

That we, _____

_____ hereinafter referred to as

“Contractor”, as principal, and _____

_____ as surety, are held and firmly

bound unto City of La Habra in the sum of _____

_____ Lawful money of the United States of America for the payment of which sum well and truly to be made we bind ourselves jointly and severally, firmly by these presents.

The condition of the foregoing obligation is such that WHEREAS, said Contract has been awarded and is about to enter into the annexed contract with City of La Habra for construction of Street Improvements as specifically set forth in the documents entitled:

**MONTE VISTA STREET REHABILITATION PROJECT
FISCAL YEAR 2022-2023
CITY PROJECT NO. 2-R-22**

and is required under the terms of the Contract to give this bond in connection with the execution of said contract.

NOW, THEREFORE, if the said Contractor shall well and truly do and perform all of the covenants and obligations of said contract on his part to be done and performed at the times and in the manner specified herein, then this obligation shall be null and void, otherwise it shall be and remain in full force and effect.

PROVIDED, that any alterations in the work to be done or the materials to be furnished which may be made pursuant to the terms of said Contract shall not in any way release either the Contractor or the surety thereunder nor shall any extensions of time granted under the provisions of said Contract release either the Contractor or the surety, and notice of such alterations or extensions of the Contract is hereby waived by the surety.

WITNESS our hands this _____ day of _____, 2024.

Contractor

BY: _____

(Seal)

Title

APPROVED:

Surety

BY: _____

(Seal)

Mailing Address of Surety:

Telephone Number of Surety

(Use of City form is required)

SUPPLEMENTAL INFORMATION TO BE COMPLETED BY PRINCIPAL

If an individual, so state. If a firm or co-partnership, state the firm and give the names of all individual co-partners composing the partnership. If a Corporation, state legal name of corporation; state also the names of the president, secretary, treasurer and manager thereof.

Business Address:

Telephone Number:

Date:

Print Name:

Principal

Signature:

Title

(Use of City form is required)

TAX IDENTIFICATION NUMBER

The Tax Equity and Fiscal Responsibility Act of 1982 requires the payer (City of La Habra) to report to the Internal Revenue Service taxable payments to payees.

You (as a payee) are required by law to provide us with your Taxpayer Identification Number (if an individual or partnership, your Social Security Number). If you do not provide us with your correct identification number, you may be subject to a penalty imposed by the Internal Revenue Service. The payments subject to withholdings may include, but are not limited to, interest, dividends, or other payments the City of La Habra made to you. Other payments may include rents, royalties, commissions and fees for service of non-employees.

If you are exempt from income tax, we are still required, by law, to maintain a Tax Identification Number on file. **PLEASE PROVIDE YOUR TAX IDENTIFICATION NUMBER next to the appropriate listing below, sign, date and return to:**

CITY OF LA HABRA FINANCE DEPARTMENT
110 E. La Habra Blvd
La Habra, CA 90631

Exempt: Yes___ No___ Telephone () _____

CORPORATION: _____

U.S.A. OR ANY AGENCIES THEREOF: _____

IRS CODE #501 TAX-EXEMPT ORGANIZATION: _____

A NON-COMMISSIONED CITY OF LA HABRA EMPLOYEE: _____

SOLE PROPRIETOR: _____

A PARTNERSHIP: _____

OTHER: _____ (Explain)

Signature/Title: _____ Date: _____

BID GUARANTEE

**TO THE CITY OF LA HABRA
MONTE VISTA REHABILITATION PROJECT, CITY PROJECT NO. 2-R-22**

As a material inducement to the City to award the contract for Project No. _____ to _____, the undersigned (“Guarantor”) has agreed to enter into this guarantee. The Guarantor hereby unconditionally guarantees to the fullest extent allowed by law the following work included in this project: _____ (“the work”).

Guarantor guarantees that the materials and equipment used by itself and its subcontractors will be free from defects and that the work will conform to the plans and specifications. Should any of the materials or equipment prove defective or should the work as a whole, or any part thereof, prove defective for any reason whatsoever (except due to intentional torts by the City), or should the work as a whole or any part thereof fail to operate properly or fail to comply with the plans and specifications, Guarantor will, at the City’s sole election: 1) reimburse the City, upon written demand, for all of the City’s expenses incurred replacing or restoring any such equipment or materials, including the cost of any work necessary to make such replacement or repairs; or 2) replace any such defective material or equipment and repair said work completely, all without any cost to the City. Guarantor further guarantees that any such repair work will conform to the plans and specifications for the project. This guarantee will remain in effect for one year from the date on which the contracted for work is accepted for use by the City.

Guarantor understands and agrees that the City shall have the unqualified option to make any replacements or repairs itself or to have such replacement, repair, performed by the undersigned. The City shall have no obligation to consult with Guarantor before the City proceeds to perform any repair, replacement, or work itself. If the City elects to have Guarantor perform said repair, replacement, or work, Guarantor agrees that the repair, replacement, or work shall be performed within 15 days after receipt of a written demand from the City.

If the City elects to perform the replacement, repairs itself, Guarantor agrees to make reimbursement payment within 15 days after receipt of a written demand for payment from the City.

If the Guarantor fails or refuses to comply with this guarantee, the City shall be entitled to all costs and expenses, including attorneys and expert fees, reasonably incurred by reason of Guarantor’s failure or refusal.

Guarantor _____ Date: _____

Contractor: _____ By: _____

Title: _____

STATEMENT OF NON COLLUSION BY CONTRACTOR

The undersigned who submits herewith to the City of La Habra a bid or proposal does hereby certify:

- a. That all statements of fact in such bid or proposal are true;
- b. That such bid or proposal was not made in the interest of or on behalf of any undisclosed person, partnership, company, association, organization or corporation;
- c. That such bid or proposal is genuine and not collusive or sham;
- d. That said bidder has not, directly or indirectly by agreement, communication or conference with anyone, attempted to induce action prejudicial to the interest of the City of La Habra or of any other bidder or anyone else interested in the proposed procurement;
- e. Did not, directly or indirectly, collude, conspire, connive or agree with anyone else that said bidder or anyone else would submit a false or sham bid or proposal, or that anyone should refrain from bidding or withdraw his bid or proposal;
- f. Did not in any manner, directly or indirectly seek by agreement, communication or conference with anyone to raise or fix the bid or proposal price of said bidder or of anyone else, or to raise or fix any overhead, profit or cost element of his bid or proposal price, or that of anyone else;
- g. Did not, directly or indirectly, submit his bid or proposal price or any breakdown thereof, or the contents thereof, or divulge information or data relative thereto, to any corporation, partnership, company, association, organization, bid depository, or to any member agent thereof, or to any individual or group of individuals, except to the City of La Habra, or to any person or persons who have a partnership or their financial interest with said bidder in his business.
- h. Did not provide, directly or indirectly to any officer or employee of the City of La Habra any gratuity, entertainment, meals, or anything of value, whatsoever, which could be objectively construed as intending to invoke any form of reciprocation or favorable treatment.
- i. That no officer or principal of the undersigned firm is related to any officer or employee of the city by blood or marriage within the third degree or is employed, either full or part time, by the City of La Habra either currently or within the last two (2) years.
- j. That no officer or principal of the undersigned firm nor any subcontractor to be engaged by the principal has been convicted by a court of competent jurisdiction of any charge of fraud, bribery, collusion, conspiracy or any other act in violation of any state or federal antitrust law in connection with the bidding upon award of, or performance of, any public work contract, with any public entity, within the last three years.

I certify, under penalty of perjury under the laws of the State of California, that the foregoing is true and correct and that this certification was executed:

On _____ at _____ California.

Firm _____

(Signature)

Street _____

(Print Name & Title)

City _____ State _____ Zip _____

CERTIFICATION OF COMPLIANCE

AFFIRMATIVE ACTION REQUIREMENTS

EQUAL EMPLOYMENT OPPORTUNITY

For

**MONTE VISTA STREET REHABILITATION PROJECT
FISCAL YEAR 2022-2023
CITY PROJECT NO. 2-R-22**

_____ Certifies that:

(Contractor)

It has adopted and approved affirmative action plan in compliance with Title VII of the Civil Rights Act and the Equal Employment Opportunity Act of 1972 and agrees to submit a copy of that plan to the Assistant to the City Manager/Personnel of the City of La Habra for inspection prior to the award of contract.

Signed: _____

By: _____

Title: _____

Date: _____

EXHIBIT A
SCOPE OF SERVICES

EXHIBIT B
INSURANCE REQUIREMENTS

Contractor shall maintain and shall require all of its subcontractors, consultants, and other agents to maintain the insurance listed below. Any requirement for insurance to be maintained after completion of the work shall survive this agreement.

CITY reserves the right to review any and all of the required insurance policies and/or endorsements, but has no obligation to do so. Failure to demand evidence of full compliance with the insurance requirements set forth in this agreement or failure to identify any insurance deficiency shall not relieve Contractor from, nor be construed or deemed a waiver of, its obligation to maintain the required insurance at all times during the performance of this agreement.

A. Workers Compensation & Employers Liability Insurance

- Workers Compensation insurance with statutory limits as required by the Labor Code of the State of California.
- Employers Liability with limits of \$1,000,000 per Accident; \$1,000,000 Disease per employee; \$1,000,000 Disease per policy.
- The policy shall include a written waiver of the insurer's right to subrogate against CITY.
- Required Evidence Of Coverage:
 1. Subrogation waiver endorsement; and
 2. Properly completed Certificate of Insurance.

B. General Liability Insurance

- Commercial General Liability Insurance no less broad than Insurance Services Office (ISO) form CG 00 01.
- Coverage shall be on a standard occurrence form. Claims-Made forms are not acceptable without prior written consent. Modified, limited or restricted Occurrence forms are not acceptable without prior written consent.
- Minimum Limits: \$2,000,000 per Occurrence; \$4,000,000 General Aggregate; \$4,000,000 Products/Completed Operations Aggregate. The General Aggregate shall apply separately to each project. The required limits may be provided by a combination of General Liability Insurance and Commercial Excess or Umbrella Liability Insurance. If contractor maintains higher limits than the specified minimum limits, CITY requires and shall be entitled to coverage for the higher limits maintained by contractor.
- Any deductible or self-insured retention shall be shown on the Certificate of Insurance. If the deductible or self-insured retention exceeds \$25,000 it must be approved in advance by CITY. Contractor is responsible for any deductible or self-insured retention and shall fund it upon CITY'S written request, regardless of whether Contractor has a claim against the insurance or is named as a party in any action involving CITY.
- Coverage shall be continued for one (1) year after completion of the work.
- CITY shall be endorsed as an additional insured for liability arising out of ongoing and completed operations by or on behalf of the contractor. CITY shall continue to be an additional insured for completed operations for (1) year after completion of the work.
- The policy definition of "insured contract" shall include assumptions of liability

arising out of both ongoing operations and the products-completed operations hazard (“P” definition of insured contract in ISO form CG 00 01, or equivalent).

- The insurance provided to the additional insureds shall be primary to, and non-contributory with, any insurance or self-insurance program maintained by them.
- The policy shall cover inter-insured suits and include a “Separation of Insureds” or “severability” clause which treats each insured separately.
- The policy shall be endorsed to include a written waiver of the insurer’s right to subrogate against all persons or entities that are, or are required to be, additional insureds.
- The policy shall not contain a Contractors' Warranty or other similar language which eliminates or restricts insurance because of a subcontractor's failure to carry specific insurance or to supply evidence of such insurance.
- Required Evidence of Coverage:
 1. Copy of the additional insured endorsement or policy language granting additional insured status;
 2. Copy of the endorsement or policy language indicating that coverage applicable to the additional insureds is primary and non-contributory;
 3. Properly completed Certificate of Insurance; and
 4. Completed and signed Agent/Broker Questionnaire with supporting documentation as required.

C. Automobile Liability Insurance

- Minimum Limit: \$2,000,000 combined single limit per accident.
- Coverage shall apply to all owned, hired and non-owned vehicles.
- CITY shall qualify as an insured.
- Required Evidence of Coverage:
 1. Copy of the endorsement or policy language indicating that CITY is an insured; and
 2. Properly completed Certificate of Insurance.

D. Surety Bonds

- Bid bond.
- Performance and payment bonds for the entire contract price.
- The surety must be authorized to issue these bonds in the State of California.

E. Standards for Insurance Companies

- Insurers, other than the California State Compensation Insurance Fund, shall have an A.M. Best's rating of at least A:VII.

F. Documentation

- The Certificate of Insurance shall include the following reference: [Monte Vista Street Rehabilitation Project. Fiscal Year 2022-2023 City of La Habra Project 2-R-22]
- The name and address for Additional Insured endorsements and Certificates of Insurance is: City of La Habra

- Contractor shall provide immediate written notice if: (1) any of the required insurance policies is terminated; (2) the limits of any of the required policies are reduced; or (3) the deductible or self-insured retention is increased.
- Current Evidence of Coverage shall be provided for the entire required period of insurance.
- Upon written request, certified copies of required insurance policies shall be provided within thirty (30) days.

EXHIBIT C

CERTIFICATES OF INSURANCE AND ENDORSEMENTS

EXHIBIT D
CLAIMS PROCEDURE

SUMMARY OF PUBLIC CONTRACT CODE § 9204

The following procedure will apply to any claims by the Contractor on the City:

A “claim” is a separate demand on the City by a contractor on a public works project and sent by registered mail or certified mail with return receipt requested, for one or more of the following:

- A time extension, including relief from penalties for delay
- Payment by the City of money damages under the terms of the contract
- Payment of an amount that is disputed by the City

Initial Review

The claim must be supported by appropriate documentation. The City has 45 days within which to review the claim and provide the contractor with a written statement identifying the disputed and undisputed portions of the claim. If the City does not issue a written statement, the claim is deemed rejected in its entirety. The City will pay any undisputed portion of the claim within 60 days of issuing the statement.

Meet & Confer

If the contractor disputes the City’s written response, or if the City does not issue one, the contractor may request in writing an informal conference to meet and confer for possible settlement of the claim. The City will schedule the meet and confer conference within 30 days of this request and provide a written statement identifying the remaining disputed and undisputed portions of the claim within 10 business days of the meet and confer. The City will pay the undisputed portion within 60 days of issuing this statement.

Mediation

With respect to any disputed portion remaining after the meet and confer, the City and contractor will submit the matter to nonbinding mediation, agree to a mediator within 10 business days after issuing the written statement, and share mediation costs equally. If mediation is unsuccessful, then the terms of the public works agreement and applicable law will govern resolution of the dispute.

Miscellaneous Provisions

Amounts not paid by the City in a timely manner bear interest at 7% per annum. Subcontractors may submit claims via this procedure through the general contractor. The City and contractor may waive the requirement to mediate, but cannot otherwise waive these claim procedures.

APPENDIX “A”

PLANS

CITY OF LA HABRA ENGINEERING DEPARTMENT
MONTE VISTA-LAMBERT RD. TO LA HABRA BLVD.
STREET REHABILITATION
PROJECT NO. 2-R-22
FY 2022-2023

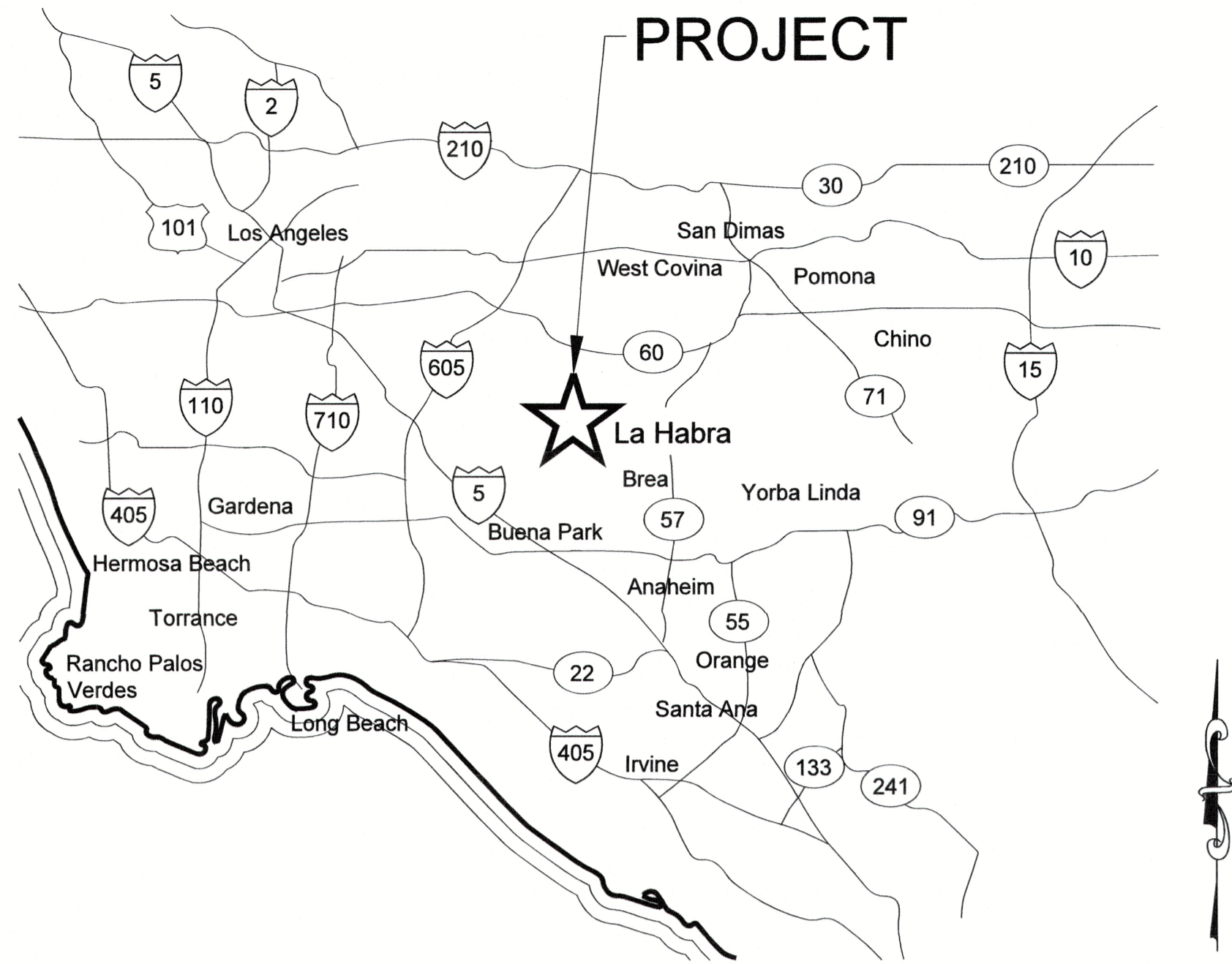

LOCATION MAP
N.T.S.

GENERAL NOTES

- ALL WORK SHALL CONFORM TO THE LATEST EDITION OF THE APWA STANDARD SPECIFICATIONS FOR PUBLIC WORKS CONSTRUCTION (GREEN BOOK), CALIFORNIA DEPARTMENT OF TRANSPORTATION STANDARD PLANS & SPECIFICATIONS, CITY OF LA HABRA STANDARD PLANS, AND PROJECT SPECIAL PROVISIONS, EACH OF THE MOST RECENT DATE.
- THE CONTRACTOR SHALL OBTAIN ALL NECESSARY PERMITS AND NOTIFY THE CITY OF LA HABRA AT LEAST TWO WORKING DAYS (48 HOURS) PRIOR TO STARTING CONSTRUCTION.
- TRAFFIC CONTROL AND SAFETY DEVICES SHALL BE INSTALLED PER THE STATE OF CALIFORNIA MANUAL OF UNIFORM TRAFFIC CONTROL DEVICES (CA MUTCD), AND TO THE SATISFACTION OF THE CITY INSPECTOR.
- IT SHALL BE THE CONTRACTOR'S RESPONSIBILITY TO ARRANGE FOR AND COORDINATE THE RELOCATION OF ANY EXISTING UTILITIES DEEMED NECESSARY BY THE PROPOSED IMPROVEMENTS.
- THE CONTRACTOR SHALL BE RESPONSIBLE FOR PROTECTION OF ALL EXISTING UTILITIES. ANY DAMAGE TO SUCH FACILITIES CAUSED BY HIS WORK SHALL BE REPAIRED BY THE CONTRACTOR AT HIS EXPENSE.
- THE CONTRACTOR SHALL MAINTAIN ADJACENT STREETS AND ALLEYS IN A NEAT, CLEAN, DUST FREE AND SANITARY CONDITION TO THE SATISFACTION OF THE CITY'S INSPECTOR. THE ADJACENT STREETS AND ALLEYS SHALL BE KEPT CLEAN OF DEBRIS, WITH DUST AND OTHER NUISANCES BEING CONTROLLED AT ALL TIMES. THE CONTRACTOR SHALL BE RESPONSIBLE FOR ANY CLEAN UP ON ADJACENT STREETS AND ALLEYS AFFECTED BY HIS CONSTRUCTION. STOCKPILING OF MATERIALS WITHIN THE PUBLIC RIGHT-OF-WAY IS NOT ALLOWED WITHOUT PRIOR WRITTEN APPROVAL OF THE CITY ENGINEER.
- NEW CONCRETE SHALL MATCH EXISTING CONCRETE IN COLOR, FINISH, AND TEXTURE, TO THE APPROVAL OF THE CITY ENGINEER.
- CONTRACTOR SHALL OBTAIN ALL REQUIRED O.S.H.A. PERMITS PRIOR TO CONSTRUCTION OF UNDERGROUND FACILITIES.
- ACCESS RAMPS, DRIVEWAY APRONS, SLABS, WALLS, FENCES, CURBS, OR GUTTERS DISTURBED BY CONSTRUCTION SHALL BE REPLACED.
- ALL SAWCUTS SHALL BE DONE BY THE WET-CUT METHOD, UNLESS OTHERWISE APPROVED BY THE CITY ENGINEER, AND ALL SLURRY SHALL BE VACUUM REMOVED.
- THE CONTRACTOR SHALL UTILIZE BEST MANAGEMENT PRACTICES FOR THE CONTROL OF EROSION AND RUNOFF, AND PROTECTION OF EXISTING STORM DRAIN FACILITIES.
- PLACEMENT AND SCHEDULING OF PAVEMENT MARKINGS AND STRIPING SHOULD BE DETERMINED BY THE CITY ENGINEER.
- STRICT ADHERENCE TO DUST CONTROL REQUIREMENTS SHALL BE ENFORCED AND ALL DUST SHALL BE CONTROLLED BY WATERING UNLESS OTHERWISE APPROVED BY THE ENGINEER.
- PRIOR TO TAKING ANY WATER FROM A FIRE HYDRANT, THE CONTRACTOR SHALL MAKE ARRANGEMENTS TO OBTAIN A FIRE HYDRANT METER.
- ALL SURVEY MONUMENTS SHALL BE PROTECTED AND PERPETUATED IN PLACE. ANY DISTURBED OR COVERED MONUMENTS SHALL BE RESET BY A QUALIFIED REGISTERED CIVIL ENGINEER OR LICENSED LAND SURVEYOR.
- ANY CONTRACTOR PERFORMING WORK ON THIS PROJECT SHALL VISIT THE LOCATION OF WORK, FAMILIARIZE THEMSELVES WITH THE WORK SITE, SLOPES, LANDSCAPING AND STRUCTURES AND SHALL BE SOLELY RESPONSIBLE FOR ANY DAMAGE TO EXISTING FACILITIES RESULTING DIRECTLY OR INDIRECTLY FROM THEIR OPERATION WEATHER OR NOT SUCH FACILITIES ARE SHOWN ON THESE PLANS.
- CONTRACTOR SHALL INSTALL ALL STRIPING IN 2 COATS, 7 DAYS BETWEEN COATS UNLESS SPECIFIED OTHERWISE.
- TRAFFIC CONTROL PLAN TO BE APPROVED BY CITY PRIOR TO START OF CONSTRUCTION ACTIVITY. (REQUIRED FOR PERMIT.)

UTILITY CONTACTS

| | | |
|--|--------------------|----------------|
| AT&T | YVETTE GAROFANO | (714) 618-9146 |
| CALIFORNIA DOMESTIC WATER COMPANY | CHE VENEGAS | (562) 947-3811 |
| CHEVRON USA | DAVE ZERLER | (310) 669-4014 |
| CITY OF LA HABRA SEWER AND WATER DEPT. | BRIAN JONES | (562) 383-4170 |
| COMCAST CABLE COMPANY | SIRMADAM | (800) 501-5738 |
| CRIMSON PIPELINE | APRIL HARVEY | (562) 285-4195 |
| CRGR (WATER HAULER) | SIRMADAM | (714) 372-8209 |
| FRONTIER COMMUNICATIONS | ARIEL FATALA | (714) 375-5717 |
| KINDER MORGAN | DON QUINN | (714) 560-4400 |
| LA HABRA HEIGHTS WATER COMPANY | SIRMADAM | (562) 665-0040 |
| METROPOLITAN WATER DISTRICT | MATT PARRY | (714) 577-5084 |
| MOBIL OIL | RUTH CRONIN-FRUITT | (310) 212-1761 |
| ORANGE COUNTY SANITATION DISTRICT | DANIEL LEE | (714) 593-7176 |
| PLAINS ALL AMERICAN PIPELINE | JOE MATTEO | (562) 728-2368 |
| SO CAL EDISON | JIMMY PARKIN | (714) 578-3434 |
| SO CAL GAS | KEITH BROWN | (840) 201-8017 |
| SHELL PIPE COMPANY | CLARINDA MALDONADO | (310) 816-2063 |
| SUBURBAN WATER SYSTEMS | TOM MEDINA | (562) 755-5015 |
| SPECTRUM | DOMINIC HERNANDEZ | (714) 287-9385 |
| TORRANCE LOGISTICS COMPANY | TERI A. SHINDE | (310) 212-1794 |
| UNOCAL | ARNA ADAMS | (213) 864-5963 |
| WESCON C/O VINTAGE PRODUCTION | EMILIO RODRIGUEZ | (562) 665-9255 |
| UNDERGROUND SERVICE ALERT | SIRMADAM | (800) 422-4133 |
| ELLER MEDIA | SIRMADAM | (714) 289-2018 |
| ORANGE COUNTY FLOOD CONTROL DISTRICT | ALEC GAMEZ | (714) 788-9829 |

SHEET INDEX

| SHEET NO. | DESCRIPTION |
|-----------|----------------------------|
| 1 | TITLE SHEET |
| 2 | TYPICAL SECTIONS |
| 3 | CURB DETAILS |
| 4-8 | STREET REHABILITATION |
| 9-13 | STRIPING AND SIGNING PLANS |

NOTES TO CONTRACTOR

- ACTUAL EXISTING SITE CONDITIONS MAY DIFFER FROM THOSE SHOWN. THE CONTRACTOR SHALL VERIFY SITE CONDITIONS PRIOR TO BIDDING. LOCATION OF EXISTING AND ABANDONED UTILITIES IS UNKNOWN OR FROM RECORD DATA ONLY. THE CONTRACTOR SHALL VERIFY TO HIS SATISFACTION LOCATIONS OF ALL UTILITIES PRIOR TO BIDDING AND CONSTRUCTION. CONTRACTOR SHALL MAINTAIN AS-BUILT RECORDS OF EXISTING UTILITIES AND INFORM THE ENGINEER IN CASE OF DISCREPANCIES.
- THE CONSTRUCTION CONTRACTOR AGREES THAT IN ACCORDANCE WITH GENERALLY ACCEPTED CONSTRUCTION PRACTICES, CONSTRUCTION CONTRACTOR WILL BE REQUIRED TO ASSUME SOLE AND COMPLETE RESPONSIBILITY FOR JOB SITE CONDITIONS DURING THE COURSE OF CONSTRUCTION OF THE PROJECT, INCLUDING THE SAFETY OF ALL PERSONS AND PROPERTY; THAT THIS REQUIREMENT SHALL BE MADE TO APPLY CONTINUOUSLY AND NOT TO BE LIMITED TO NORMAL WORKING HOURS, AND CONSTRUCTION CONTRACTOR FURTHER AGREES TO DEFEND, INDEMNIFY, AND HOLD DESIGN PROFESSIONAL HARMLESS FROM ANY LIABILITY, REAL OR ALLEGED, IN CONNECTION WITH THE PERFORMANCE OF WORK ON THIS PROJECT, EXCEPTING LIABILITY ARISING FROM THE SOLE NEGLIGENCE OF DESIGN PROFESSIONAL.
- THE ENGINEER PREPARING THESE PLANS WILL NOT BE RESPONSIBLE FOR, OR LIABLE FOR, UNAUTHORIZED USE OF THESE PLANS. ALL CHANGES TO THE PLANS MUST BE IN WRITING AND MUST BE APPROVED BY THE PREPARER OF THESE PLANS.

STORMWATER PERMIT (NPDES REQUIREMENTS) NOTES:

- SEDIMENT FROM AREAS DISTURBED BY CONSTRUCTION SHALL BE RETAINED ON SITE USING STRUCTURAL CONTROLS AS REQUIRED BY THE STATEWIDE GENERAL CONSTRUCTION STORMWATER PERMIT.
- STOCKPILES OF SOIL SHALL BE PROPERLY CONTAINED TO ELIMINATE OR REDUCE SEDIMENT TRANSPORT FROM THE SITE TO STREETS, DRAINAGE FACILITIES OR ADJACENT PROPERTIES VIA RUNOFF, VEHICLE TRACKING, OR WIND AS REQUIRED BY THE STATEWIDE GENERAL CONSTRUCTION STORMWATER PERMIT.
- APPROPRIATE BMPS FOR CONSTRUCTION-RELATED MATERIALS, WASTES, SPILLS OR RESIDUES SHALL BE IMPLEMENTED TO ELIMINATE OR REDUCE TRANSPORT FROM THE SITE TO STREETS, DRAINAGE FACILITIES, OR ADJOINING PROPERTIES BY WIND OR RUNOFF AS REQUIRED BY THE STATEWIDE GENERAL CONSTRUCTION STORMWATER PERMIT.
- RUNOFF FROM EQUIPMENT AND VEHICLE WASHING SHALL BE CONTAINED AT CONSTRUCTION SITES AND MUST NOT BE DISCHARGED TO RECEIVING WATERS OR THE LOCAL STORM DRAIN SYSTEM.
- ALL PERSONNEL FROM THE CONSTRUCTION CONTRACTORS AND SUBCONTRACTOR'S PERSONNEL ARE TO BE MADE AWARE OF THE REQUIRED BEST MANAGEMENT PRACTICES AND GOOD HOUSEKEEPING MEASURES FOR THE PROJECT SITE AND ANY ASSOCIATED CONSTRUCTION STAGING AREAS.
- AT THE END OF EACH DAY OF CONSTRUCTION ACTIVITY ALL CONSTRUCTION DEBRIS AND WASTE MATERIALS SHALL BE COLLECTED AND PROPERLY DISPOSED IN TRASH OR RECYCLE BINS.
- CONSTRUCTION SITES SHALL BE MAINTAINED IN SUCH A CONDITION THAT A STORM DOES NOT CARRY WASTES OR POLLUTANTS OFF THE SITE. DISCHARGES OTHER THAN STORMWATER (NON-STORMWATER DISCHARGES) ARE PROHIBITED, EXCEPT AS AUTHORIZED BY AN INDIVIDUAL NPDES PERMIT OR THE STATEWIDE GENERAL CONSTRUCTION STORMWATER PERMIT. POTENTIAL POLLUTANTS INCLUDE BUT ARE NOT LIMITED TO: SOLID OR LIQUID CHEMICAL SPILLS; WASTES FROM PAINTS, STAINS, SEALANTS, SOLVENTS, DETERGENTS, GLUES, LIME, PESTICIDES, HERBICIDES, FERTILIZERS, WOOD PRESERVATIVES, AND ASBESTOS FIBERS, PAINT FLAKES OR STUCCO FRAGMENTS; FUELS, OILS, LUBRICANTS, AND HYDRAULIC, RADIATOR OR BATTERY FLUIDS; CONCRETE AND RELATED CUTTING OR CURING RESIDUES; FLOATABLE WASTES; WASTES FROM ENGINE/EQUIPMENT STEAM CLEANING OR CHEMICAL DEGREASING; WASTES FROM STREET CLEANING; AND SUPER-CHLORINATED POTABLE WATER FROM LINE FLUSHING AND TESTING.
- DURING CONSTRUCTION, DISPOSAL OF SUCH MATERIALS SHOULD OCCUR IN A SPECIFIED AND CONTROLLED TEMPORARY AREA ON-SITE PHYSICALLY SEPARATED FROM POTENTIAL STORMWATER RUNOFF, WITH ULTIMATE DISPOSAL IN ACCORDANCE WITH LOCAL, STATE AND FEDERAL REQUIREMENTS. DISCHARGING CONTAMINATED GROUNDWATER PRODUCED BY DEWATERING GROUNDWATER THAT HAS INFILTRATED INTO THE CONSTRUCTION SITE IS PROHIBITED. DISCHARGING OF CONTAMINATED SOILS VIA SURFACE EROSION IS ALSO PROHIBITED.
- DISCHARGING NONCONTAMINATED GROUNDWATER PRODUCED BY DEWATERING ACTIVITIES REQUIRES A NATIONAL POLLUTANT DISCHARGE ELIMINATION SYSTEM (NPDES) PERMIT FROM THE RESPECTIVE STATE REGIONAL WATER QUALITY CONTROL BOARD.

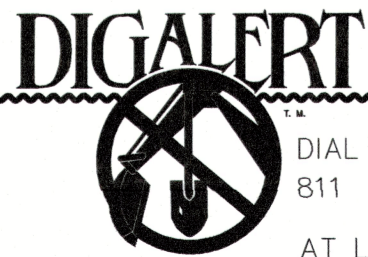

DIAL TOLL FREE
811
AT LEAST TWO DAYS
BEFORE YOU DIG
UNDERGROUND SERVICE ALERT OF SOUTHERN CALIFORNIA

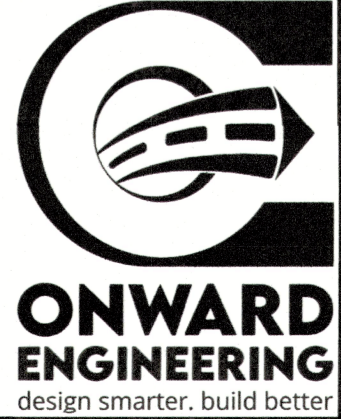

| | | | | |
|--|--|--|--|---|
| CITY OF LA HABRA MONTE VISTA STREET STREET REHABILITATION TITLE SHEET | | DESIGNED: <i>JLS</i> JUSTIN SMEETS P.E. DATE: 03-20-2024 | CITY ENGINEER: <i>AM</i> ALBERT MENDOZA P.E. 90882 DATE: 3-21-24 | PROJECT NO. 2-R-22 SHEET 01 of 13 |
| | | REVISIONS 1 2 3 4 | DATE DESCRIPTION BY | DATE DESCRIPTION BY |

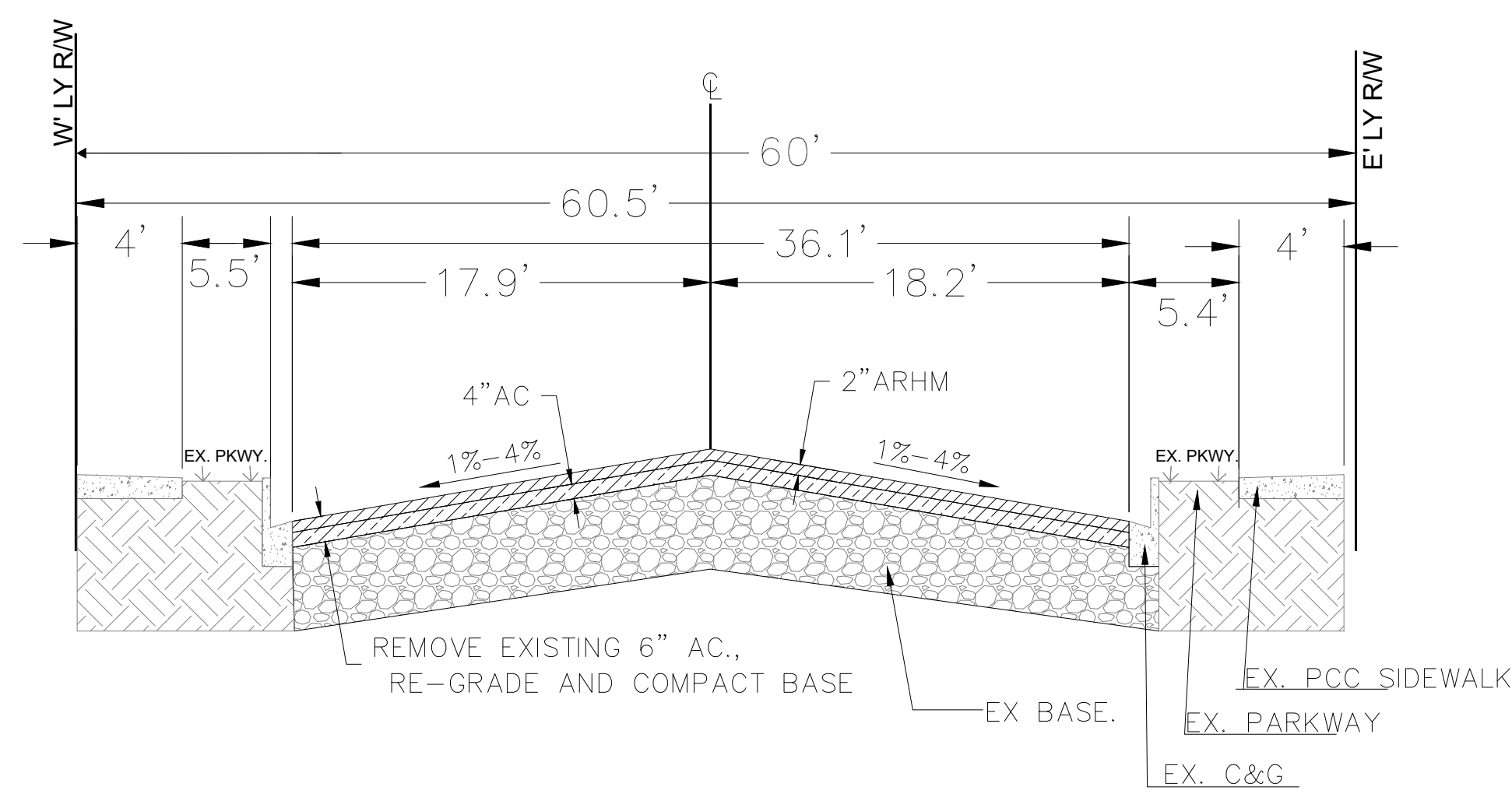

TYPICAL SECTION - MONTE VISTA ST
 STA 10+77 TO 13+49
 AND
 STA 14+09 TO 16+85 N.T.S.

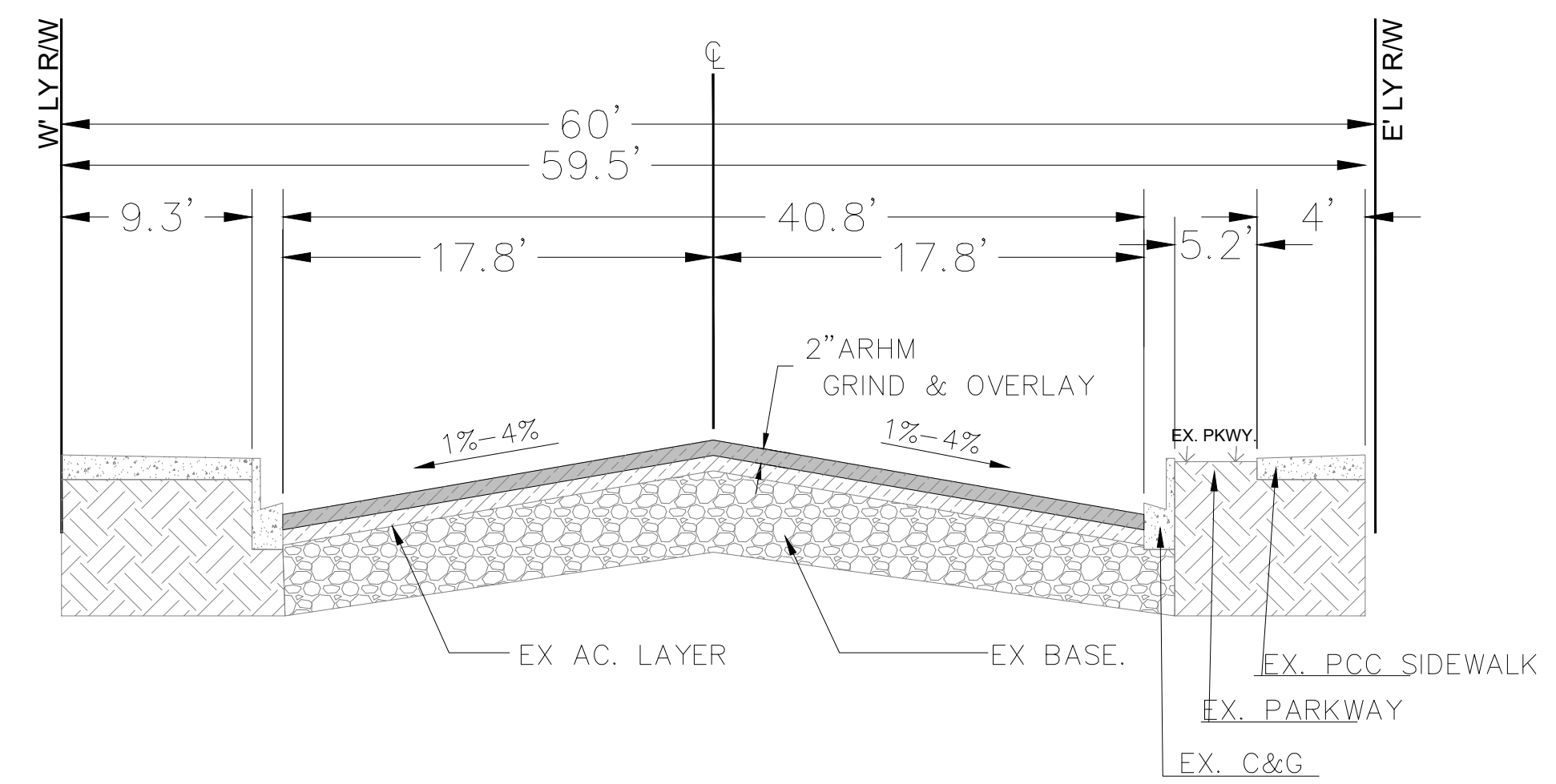

TYPICAL SECTION - MONTE VISTA ST
 STA 13+49 TO 14+09
 AND
 STA 16+85 TO 35+97 N.T.S.

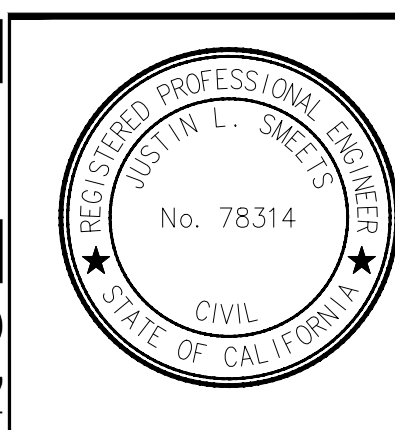

| | |
|--|---|
| CITY OF LA HABRA | |
| MONTE VISTA STREET TYPICAL SECTIONS | |
| LAMBERT RD. TO LA HABRA BLVD. | |
| DESIGNED BY JUSTIN SMEETS P.E. DATE 03-20-2024 | PROJECT NO. 2-R-22 SHEET 02 of 13 |

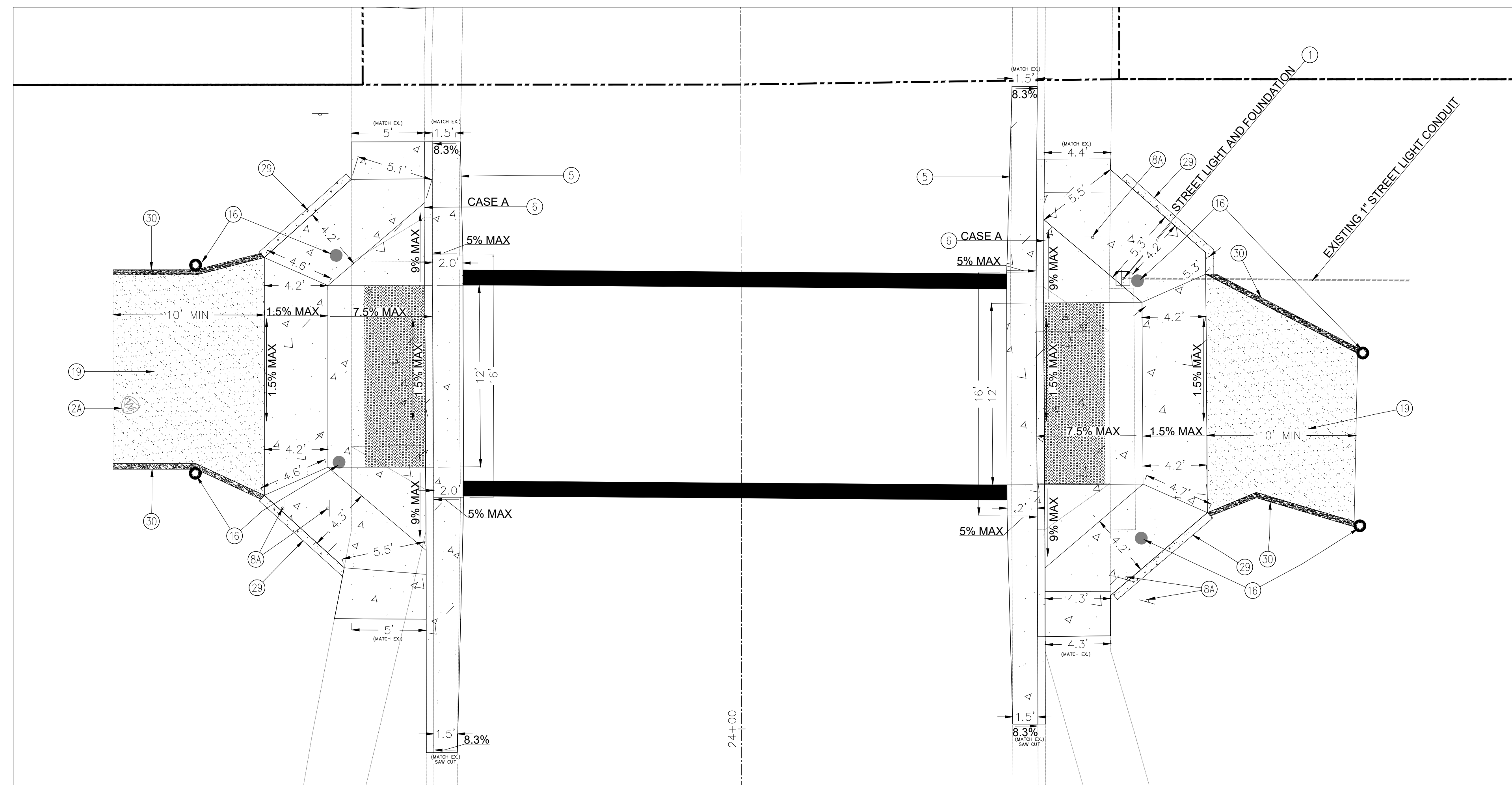

DETAIL A

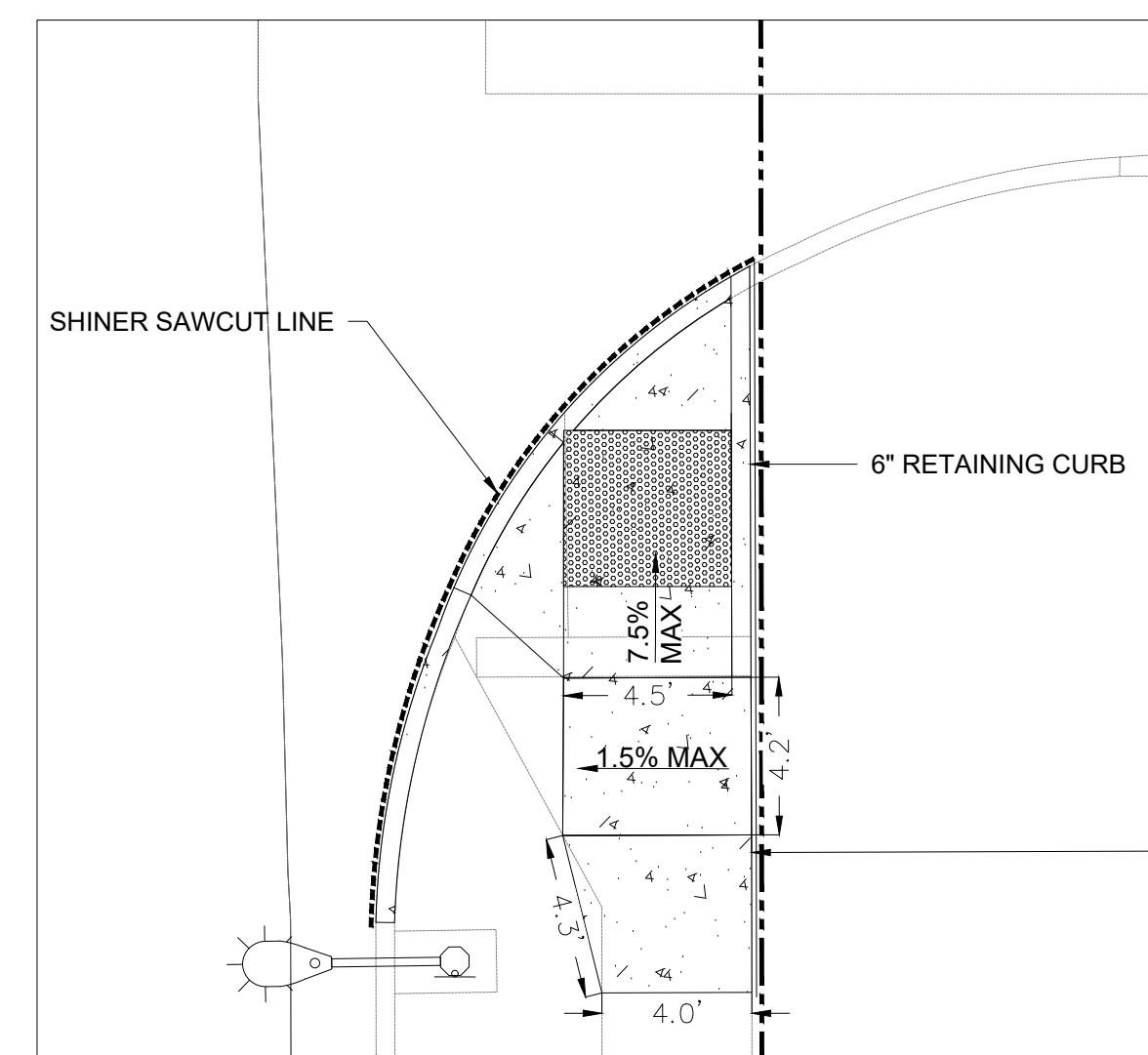
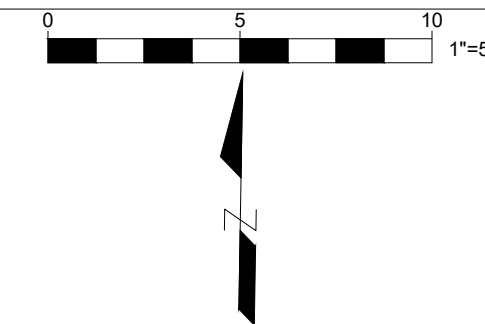



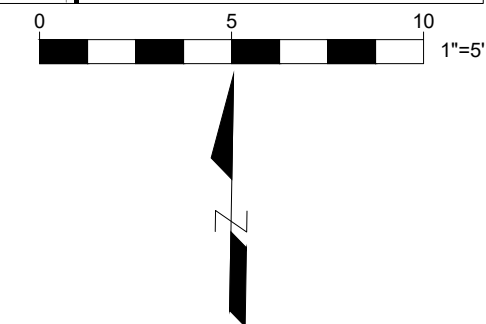

DETAIL B

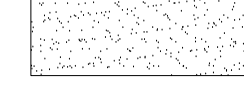

CONSTRUCTION NOTES

- 1 PROTECT IN PLACE ITEM AS NOTED ON PLAN.
- 2A ADJUST VALVE TO GRADE AS NOTED ON PLAN.
- 5 SAWCUT AND REMOVE EXISTING CURB AND GUTTER. CONSTRUCT NEW VARIABLE HEIGHT PCC CURB AND GUTTER PER LA HABRA STANDARD DETAIL R-13, TYPE A2-8.
- 6 SAWCUT AND REMOVE EXISTING CURB RAMP. CONSTRUCT NEW 4" PCC CURB RAMP PER CALTRANS STANDARD PLAN RSP AB8A, CASE B, UNLESS OTHERWISE NOTED ON PLAN OR DIRECTED BY CITY IN FIELD, 1" WIDE AC SLOT PATCH. TYPE C2 PG 64-10.
- 8A REMOVE EXISTING TELESPEAR POST AND RELOCATE SIGN TO NEW TELESPEAR POST PER PLAN, OR AS DIRECTED BY CITY IN FIELD.
- 16 REMOVE AND RELOCATE BOLLARD PER PLAN, OR AS DIRECTED BY CITY IN FIELD.
- 19 FULL DEPTH EXCAVATION 4" AND PLACE 4" THICK C2 PG 64-10 WEARING COURSE TO MATCH NEW PCC SIDEWALK.
- 29 INSTALL 6" MIN HEIGHT RETAINING CURB.
- 30 INSTALL 2"x4" REDWOOD HEADER AT EDGE OF ASPHALT, STAKED 24" ON CENTER AT 12" DEPTH.

-  PCC CONCRETE PAVEMENT IMPROVEMENTS.
-  ASPHALT PAVEMENT IMPROVEMENTS.
-  2"x4" REDWOOD HEADER.

| CITY OF LA HABRA | | | | | | | | | | | | | |
|--|---|-------------|-------------|----|---|--|--|--|---|-----------------------------------|---|---------------------|------------------|
| MONTE VISTA STREET CURB DETAILS | | | | | | | | | | | | | |
| LAMBERT RD. TO LA HABRA BLVD. | | | | | | | | | | | | | |
| <table border="1" style="width: 100%; border-collapse: collapse;"> <thead> <tr> <th style="width: 5%;">REV.</th> <th style="width: 15%;">DATE</th> <th style="width: 40%;">DESCRIPTION</th> <th style="width: 40%;">BY</th> </tr> </thead> <tbody> <tr> <td>1</td> <td></td> <td></td> <td></td> </tr> </tbody> </table> | REV. | DATE | DESCRIPTION | BY | 1 | | | | <table border="1" style="width: 100%; border-collapse: collapse;"> <tr> <td>DESIGNED BY: <i>Justin Smeets</i></td> <td rowspan="3" style="text-align: center; vertical-align: middle;">  </td> </tr> <tr> <td>JUSTIN SMEETS, P.E.</td> </tr> <tr> <td>DATE: 03-20-2024</td> </tr> </table> | DESIGNED BY: <i>Justin Smeets</i> |  | JUSTIN SMEETS, P.E. | DATE: 03-20-2024 |
| REV. | DATE | DESCRIPTION | BY | | | | | | | | | | |
| 1 | | | | | | | | | | | | | |
| DESIGNED BY: <i>Justin Smeets</i> |  | | | | | | | | | | | | |
| JUSTIN SMEETS, P.E. | | | | | | | | | | | | | |
| DATE: 03-20-2024 | | | | | | | | | | | | | |
| PROJECT NO. 2-R-22 | SHEET 03 OF 13 | | | | | | | | | | | | |

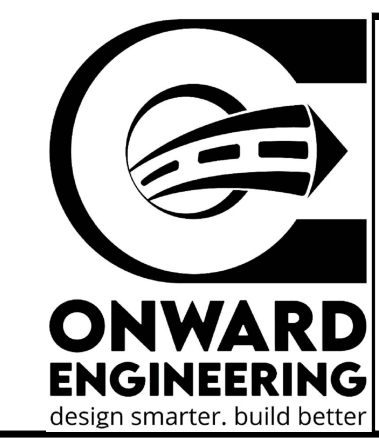

866
STA:10+77.02
BEGIN RECONSTRUCTION

W LAMBERT RD.

627

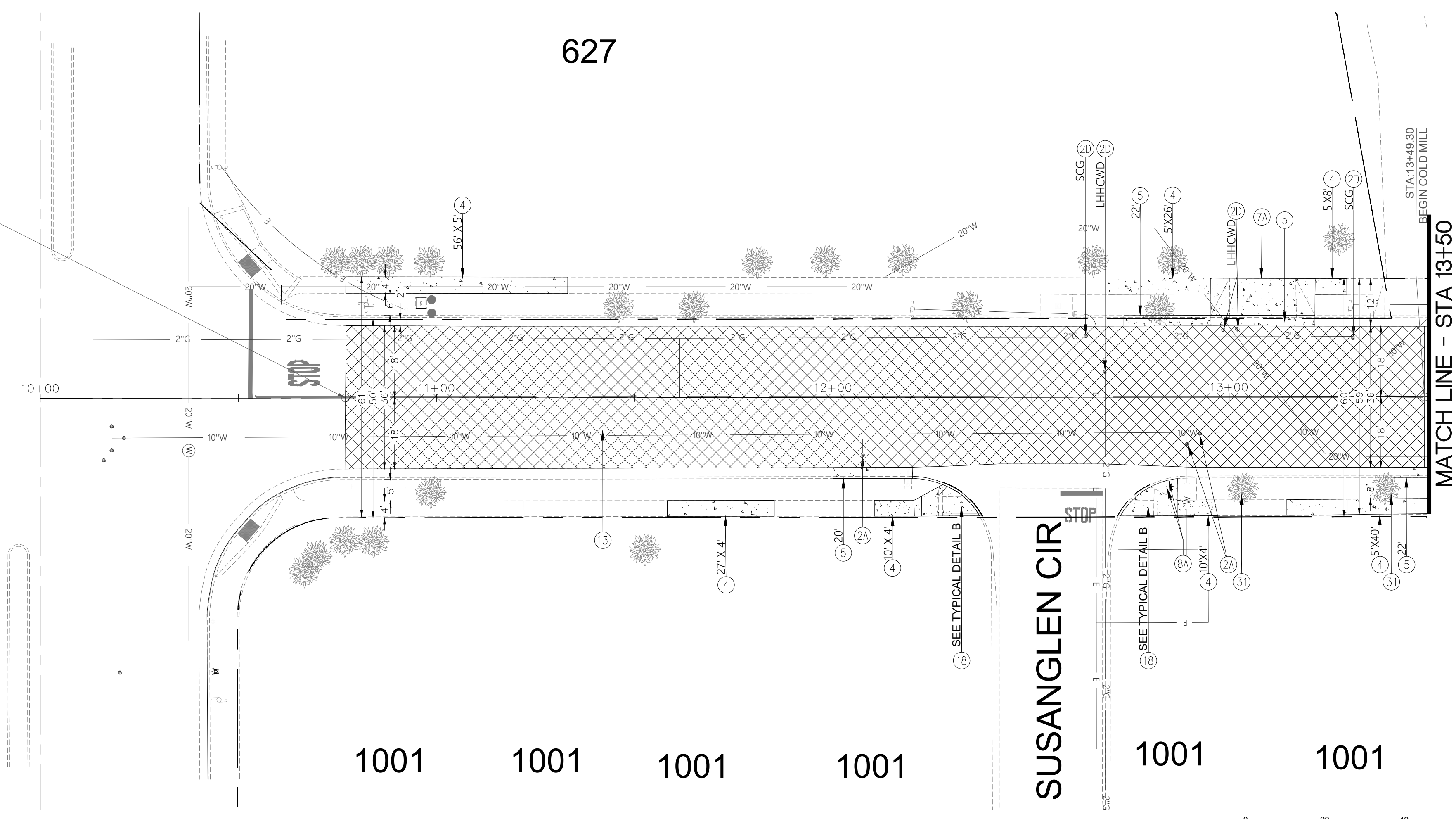

MATCH LINE - STA 13+50
SEE SHEET 5

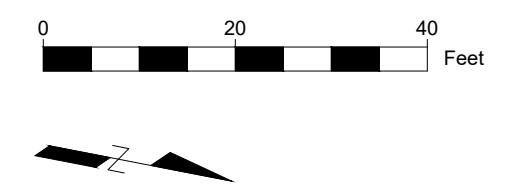

CONSTRUCTION NOTES

- (2A) ADJUST VALVE TO GRADE AS NOTED ON PLAN.
- (20) ADJUST BY OTHERS. CONTRACTOR SHALL COORDINATE WITH RESPECTIVE UTILITIES.
- (4) SAWCUT AND REMOVE EXISTING SIDEWALK. CONSTRUCT NEW 4" THICK PCC SIDEWALK.
- (5) SAWCUT AND REMOVE EXISTING CURB AND GUTTER. CONSTRUCT NEW VARIABLE HEIGHT PCC CURB AND GUTTER PER LA HABRA STANDARD DETAIL R-13, TYPE A2-8.
- (7A) SAWCUT AND REMOVE EXISTING DRIVEWAY APPROACH. CONSTRUCT NEW PCC DRIVEWAY APPROACH PER SPPWC 110-2.
- (8A) REMOVE EXISTING TELESPEAR POST AND RELOCATE SIGN TO NEW TELESPEAR POST PER PLAN, OR AS DIRECTED BY CITY IN FIELD.
- (13) REMOVE EXISTING 6" AC. RE-GRADE AND COMPACT BASE. PLACE 4" AC BASE COURSE AND THEN PLACE 2" AC ARHM OVERLAY.
- (18) SAWCUT AND REMOVE EXISTING CURB RAMP. CONSTRUCT NEW 4" PCC CURB RAMP PER MODIFIED CALTRANS STANDARD PLAN RSP A88A, CASE G OR DIRECTED BY CITY IN FIELD. MINIMUM 5' AT BACK OF RAMP AND ADJOINING SIDEWALK SECTION. SEE TYPICAL DETAIL.
- (31) COORDINATE WITH LA HABRA PARKS DIVISION ON TREE REMOVAL.

LEGEND

- CONCRETE IMPROVEMENTS.
- TRUNCATED DOMES
- LOCALIZED DIGOUTS - REMOVE EXISTING 6" AC. RE-GRADE AND COMPACT BASE. PLACE 4" AC BASE COURSE AND THEN PLACE 2" AC ARHM OVERLAY.
- 2" COLD MILL AND PLACE 2" THICK ARHM WEARING COURSE.
- REMOVE EXISTING 6" AC. RE-GRADE AND COMPACT BASE. PLACE 4" AC BASE COURSE AND THEN PLACE 2" AC ARHM OVERLAY.

NOTE
SOCAL GAS - SOUTHERN CALIFORNIA GAS COMPANY: CONTRACTOR SHALL COORDINATE WITH SOUTHERN CALIFORNIA GAS COMPANY - KEITH BROWN - (840) 201-8017.

LHHCW - LA HABRA HEIGHTS COUNTY WATER DISTRICT: CONTRACTOR SHALL COORDINATE WITH LA HABRA HEIGHTS COUNTY WATER DISTRICT - (562) 665-0040

OCFCD - ORANGE COUNTY FLOOD CONTROL DISTRICT: CONTRACTOR SHALL COORDINATE WITH OCFCD FOR MANHOLE ADJUSTMENTS ALEC GAMEZ - (714) 788-9829

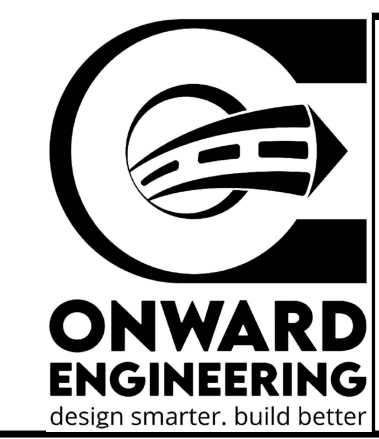

| | |
|---|--------------------|
| CITY OF LA HABRA | |
| MONTE VISTA STREET STREET REHABILITATION | |
| LAMBERT RD. TO LA HABRA BLVD. | |
| DESIGNED BY: <i>Justin Sheets</i> | PROJECT NO. 2-R-22 |
| DATE: 03-20-2024 | SHEET 04 OF 13 |

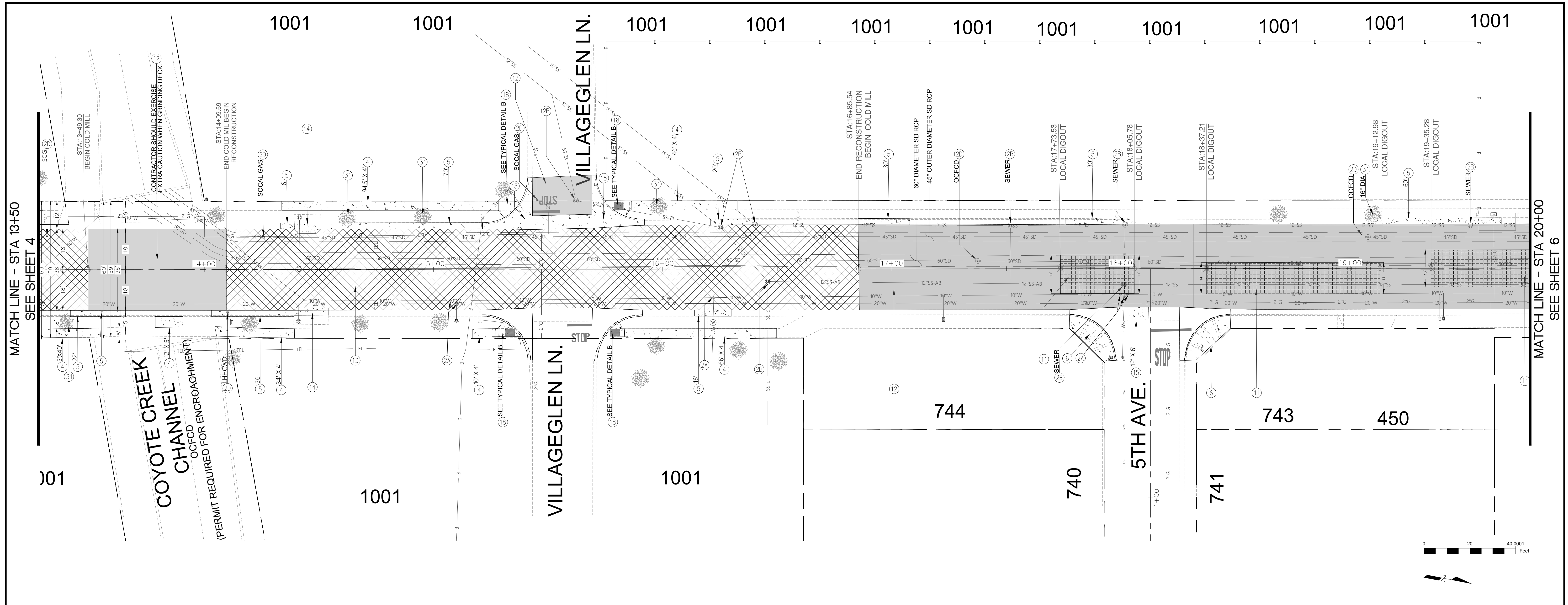

MATCH LINE - STA 13+50
SEE SHEET 4

MATCH LINE - STA 20+00
SEE SHEET 6

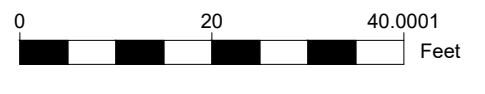

CONSTRUCTION NOTES

- (2A) ADJUST VALVE TO GRADE AS NOTED ON PLAN.
- (2B) ADJUST MANHOLE TO GRADE AS NOTED ON PLAN.
- (2D) ADJUST BY OTHERS. CONTRACTOR SHALL COORDINATE WITH RESPECTIVE UTILITIES.
- (4) SAWCUT AND REMOVE EXISTING SIDEWALK. CONSTRUCT NEW 4" THICK PCC SIDEWALK.
- (5) SAWCUT AND REMOVE EXISTING CURB AND GUTTER. CONSTRUCT NEW VARIABLE HEIGHT PCC CURB AND GUTTER PER LA HABRA STANDARD DETAIL R-13, TYPE A2-8.
- (6) SAWCUT AND REMOVE EXISTING CURB RAMP. CONSTRUCT NEW 4" PCC CURB RAMP PER CALTRANS STANDARD PLAN RSP A88A, CASE B, UNLESS OTHERWISE NOTED ON PLAN OR DIRECTED BY CITY IN FIELD, 1' WIDE AC SLOT PATCH. TYPE C2 PG 64-10.
- (11) LOCALIZED DIGOUTS - REMOVE EXISTING 6" AC. RE-GRADE AND COMPACT BASE. PLACE 4" AC BASE COURSE AND THEN PLACE 2" AC ARHM OVERLAY.
- (12) 2" COLD MILL AND PLACE 2" THICK ARHM-GG-C PG 64-16 WEARING COURSE.
- (13) REMOVE EXISTING 6" AC. RE-GRADE AND COMPACT BASE. PLACE 4" AC BASE COURSE AND THEN PLACE 2" AC ARHM OVERLAY.
- (14) SAW CUT AND REMOVE EXISTING LOCAL DEPRESSION. CONSTRUCT NEW PCC LOCAL DEPRESSION PER SPPWD STD PLAN 313-4.
- (15) SAW CUT AND REMOVE EXISTING CROSS-GUTTER AND SPANDREL. CONSTRUCT NEW PCC CROSS-GUTTER AND SPANDREL PER LA HABRA STD. DETAIL R-6 WITHOUT DOWELS OVER 6" CMB. 1' WIDE AC SLOT PATCH, TYPE C2 - PG 64 - 10.
- (18) SAWCUT AND REMOVE EXISTING CURB RAMP. CONSTRUCT NEW 4" PCC CURB RAMP PER MODIFIED CALTRANS STANDARD PLAN RSP A88A, CASE G OR DIRECTED BY CITY IN FIELD, MINIMUM 5' AT BACK OF RAMP AND ADJOINING SIDEWALK SECTION. SEE TYPICAL DETAIL.
- (31) COORDINATE WITH LA HABRA PARKS DIVISION ON TREE REMOVAL.

LEGEND

- CONCRETE IMPROVEMENTS.
- TRUNCATED DOMES
- LOCALIZED DIGOUTS - REMOVE EXISTING 6" AC. RE-GRADE AND COMPACT BASE, PLACE 4" AC BASE COURSE AND THEN PLACE 2" AC ARHM OVERLAY.
- 2" COLD MILL AND PLACE 2" THICK ARHM WEARING COURSE.
- REMOVE EXISTING 6" AC. RE-GRADE AND COMPACT BASE. PLACE 4" AC BASE COURSE AND THEN PLACE 2" AC ARHM OVERLAY.

NOTE
SOCAL GAS - SOUTHERN CALIFORNIA GAS COMPANY: CONTRACTOR SHALL COORDINATE WITH SOUTHERN CALIFORNIA GAS COMPANY - KEITH BROWN - (840) 201-8017.

LHHCWD - LA HABRA HEIGHTS COUNTY WATER DISTRICT:
CONTRACTOR SHALL COORDINATE WITH LA HABRA HEIGHTS COUNTY WATER DISTRICT - (562) 665-0040

OCFCD - ORANGE COUNTY FLOOD CONTROL DISTRICT:
CONTRACTOR SHALL COORDINATE WITH OCFCD FOR MANHOLE ADJUSTMENTS ALEC GAMEZ - (714) 788-9829

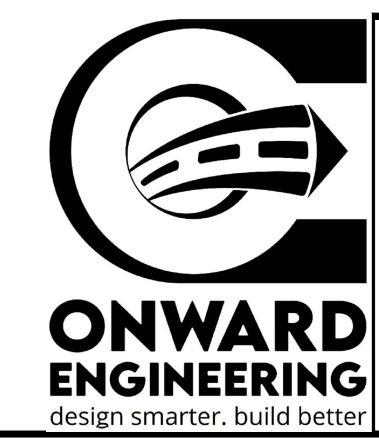

| | |
|---|-----------------------|
| CITY OF LA HABRA | |
| MONTE VISTA STREET STREET REHABILITATION | |
| LAMBERT RD. TO LA HABRA BLVD. | |
| DESIGNED BY: <i>Justin Sheets</i> | PROJECT NO. 2-R-22 |
| DATE: 03-20-2024 | SHEET 05 OF 13 |

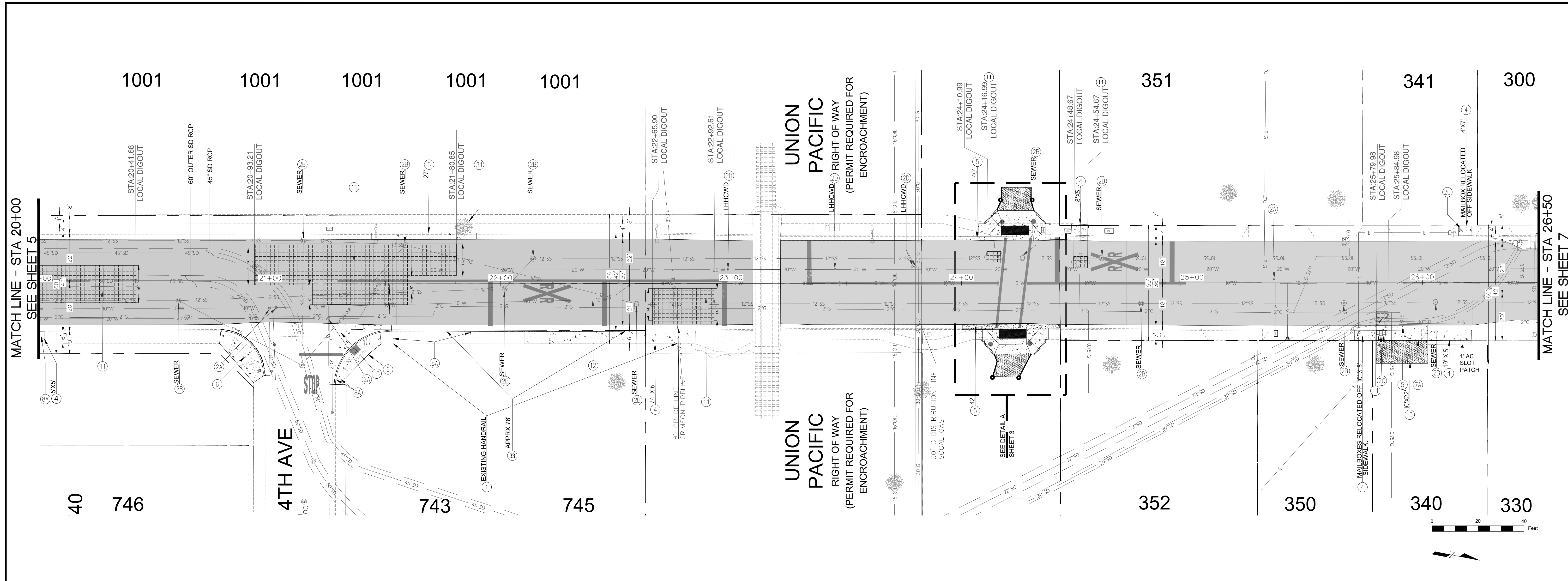

MATCH LINE - STA 20+00
SEE SHEET 5

MATCH LINE - STA 26+50
SEE SHEET 7

40 746 4TH AVE 743 745 352 350 340 330

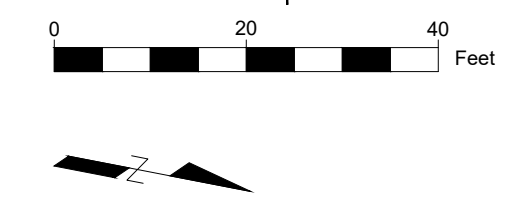

CONSTRUCTION NOTES

- 1) PROTECT IN PLACE ITEM AS NOTED ON PLAN.
- 2A) ADJUST VALVE TO GRADE AS NOTED ON PLAN.
- 2B) ADJUST MANHOLE TO GRADE AS NOTED ON PLAN.
- 2C) REPLACE PULL-BOX AS NOTED ON PLAN.
- 2D) ADJUST BY OTHERS. CONTRACTOR SHALL COORDINATE WITH RESPECTIVE UTILITIES.
- 4) SAWCUT AND REMOVE EXISTING SIDEWALK. CONSTRUCT NEW 4" THICK PCC SIDEWALK.
- 5) SAWCUT AND REMOVE EXISTING CURB AND GUTTER. CONSTRUCT NEW VARIABLE HEIGHT PCC CURB AND GUTTER PER LA HABRA STANDARD DETAIL R-13, TYPE A2-8.
- 6) SAWCUT AND REMOVE EXISTING CURB RAMP. CONSTRUCT NEW 4" PCC CURB RAMP PER CALTRANS STANDARD PLAN RSP A88A, CASE B, UNLESS OTHERWISE NOTED ON PLAN OR DIRECTED BY CITY IN FIELD, 1' WIDE AC SLOT PATCH. TYPE C2 PG 64-10.
- 7A) SAWCUT AND REMOVE EXISTING DRIVEWAY APPROACH. CONSTRUCT NEW PCC DRIVEWAY APPROACH PER SPPWC 110-2.
- 8A) REMOVE EXISTING TELES PAR POST AND RELOCATE SIGN TO NEW TELES PAR POST PER PLAN, OR AS DIRECTED BY CITY IN FIELD.
- 11) LOCALIZED DIGOUTS - REMOVE EXISTING 6" AC. RE-GRADE AND COMPACT BASE. PLACE 4" AC BASE COURSE AND THEN PLACE 2" AC ARHM OVERLAY.
- 12) 2" COLD MILL AND PLACE 2" THICK ARHM-GG-C PG 64-16 WEARING COURSE.
- 15) SAW CUT AND REMOVE EXISTING CROSS-GUTTER AND SPANDREL. CONSTRUCT NEW PCC CROSS-GUTTER AND SPANDREL PER LA HABRA STD. DETAIL R-6 WITHOUT DOWELS OVER 6" CMB. 1' WIDE AC SLOT PATCH, TYPE C2 - PG 64 - 10.
- 19) FULL DEPTH EXCAVATION 4" AND PLACE 4" THICK C2 PG 64-10 WEARING COURSE TO MATCH NEW PCC SIDEWALK.
- 31) COORDINATE WITH LA HABRA PARKS DIVISION ON TREE REMOVAL.
- 33) FILL GAP BETWEEN SIDEWALK AND BACK OF CURB WITH PCC.

LEGEND

- CONCRETE IMPROVEMENTS.
- FULL DEPTH EXCAVATION 4" THICK C2 PG 64-10 WEARING COURSE TO MATCH NEW PCC SIDEWALK.
- TRUNCATED DOMES
- LOCALIZED DIGOUTS - REMOVE EXISTING 6" AC. RE-GRADE AND COMPACT BASE. PLACE 4" AC BASE COURSE AND THEN PLACE 2" AC ARHM OVERLAY.
- 2" COLD MILL AND PLACE 2" THICK ARHM WEARING COURSE.
- REMOVE EXISTING 6" AC. RE-GRADE AND COMPACT BASE. PLACE 4" AC BASE COURSE AND THEN PLACE 2" AC ARHM OVERLAY.

NOTE
SOCAL GAS - SOUTHERN CALIFORNIA GAS COMPANY: CONTRACTOR SHALL COORDINATE WITH SOUTHERN CALIFORNIA GAS COMPANY - KEITH BROWN - (840) 201-8017.

LHHCW D - LA HABRA HEIGHTS COUNTY WATER DISTRICT:
CONTRACTOR SHALL COORDINATE WITH LA HABRA HEIGHTS COUNTY WATER DISTRICT - (562) 665-0040

OCFCD - ORANGE COUNTY FLOOD CONTROL DISTRICT:
CONTRACTOR SHALL COORDINATE WITH OCFCD FOR MANHOLE ADJUSTMENTS ALEC GAMEZ - (714) 788-9829

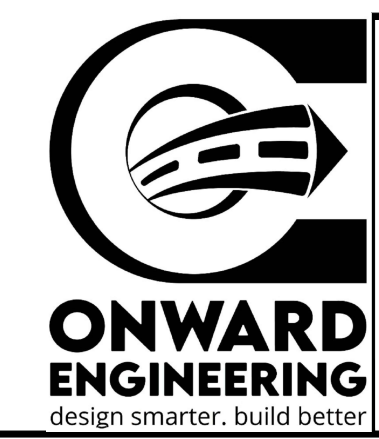

| | |
|--|---|
| <p>CITY OF LA HABRA</p> <p>MONTE VISTA STREET STREET REHABILITATION</p> <p>LAMBERT RD. TO LA HABRA BLVD.</p> | |
| <p>DESIGNED BY: <i>Justin Sheets</i></p> <p>DATE: 03-20-2024</p> | <p>PROJECT NO. 2-R-22</p> <p>SHEET 06 OF 13</p> |

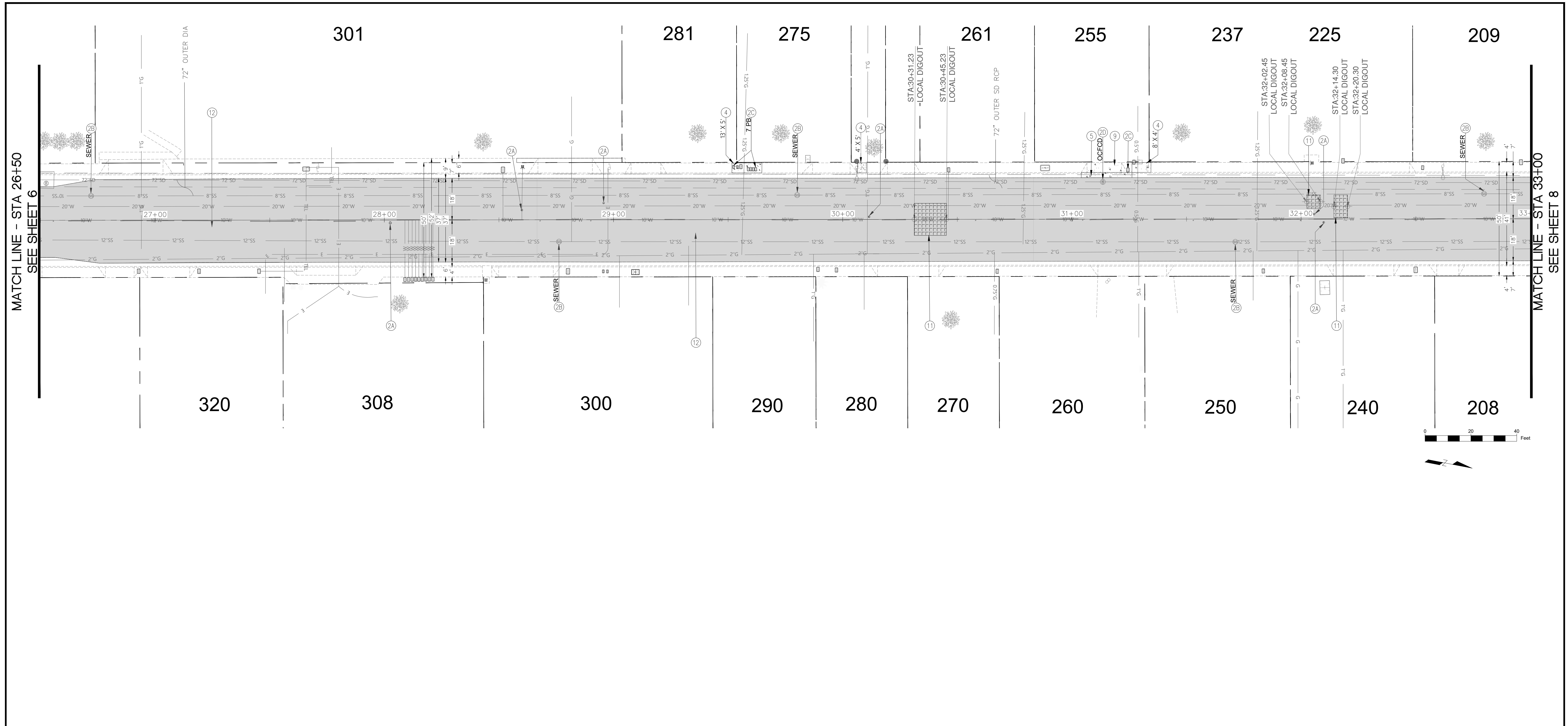

MATCH LINE - STA 261+50
SEE SHEET 6

MATCH LINE - STA 331+00
SEE SHEET 8

NOTE
 SOCAL GAS - SOUTHERN CALIFORNIA GAS COMPANY: CONTRACTOR SHALL COORDINATE WITH SOUTHERN CALIFORNIA GAS COMPANY - KEITH BROWN - (840) 201-8017.

LHHCWD - LA HABRA HEIGHTS COUNTY WATER DISTRICT:
 CONTRACTOR SHALL COORDINATE WITH LA HABRA HEIGHTS COUNTY WATER DISTRICT - (562) 665-0040

OCFCD - ORANGE COUNTY FLOOD CONTROL DISTRICT:
 CONTRACTOR SHALL COORDINATE WITH OCFCD FOR MANHOLE ADJUSTMENTS ALEC GAMEZ - (714) 788-9829

LEGEND

| | |
|--|--|
| | CONCRETE IMPROVEMENTS. |
| | TRUNCATED DOMES |
| | LOCALIZED DIGOUTS - REMOVE EXISTING 6" AC. RE-GRADE AND COMPACT BASE, PLACE 4" AC BASE COURSE AND THEN PLACE 2" AC ARHM OVERLAY. |
| | 2" COLD MILL AND PLACE 2" THICK ARHM WEARING COURSE. |
| | REMOVE EXISTING 6" AC. RE-GRADE AND COMPACT BASE. PLACE 4" AC BASE COURSE AND THEN PLACE 2" AC ARHM OVERLAY. |

- CONSTRUCTION NOTES**
- (2A) ADJUST VALVE TO GRADE AS NOTED ON PLAN.
 - (2B) ADJUST MANHOLE TO GRADE AS NOTED ON PLAN.
 - (2C) REPLACE PULL-BOX AS NOTED ON PLAN
 - (2D) ADJUST BY OTHERS. CONTRACTOR SHALL COORDINATE WITH RESPECTIVE UTILITIES.
 - (4) SAWCUT AND REMOVE EXISTING SIDEWALK. CONSTRUCT NEW 4" THICK PCC SIDEWALK.
 - (5) SAWCUT AND REMOVE EXISTING CURB AND GUTTER. CONSTRUCT NEW VARIABLE HEIGHT PCC CURB AND GUTTER PER LA HABRA STANDARD DETAIL R-13, TYPE A2-8.
 - (9) SAWCUT AND REMOVE EXISTING DRIVEWAY. CONSTRUCT NEW PCC SIDEWALK PER SPPWC STANDARD PLAN 113-2.
 - (11) LOCALIZED DIGOUTS - REMOVE EXISTING 6" AC. RE-GRADE AND COMPACT BASE. PLACE 4" AC BASE COURSE AND THEN PLACE 2" AC ARHM OVERLAY.
 - (12) 2" COLD MILL AND PLACE 2" THICK ARHM-GG-C PG 64-16 WEARING COURSE.

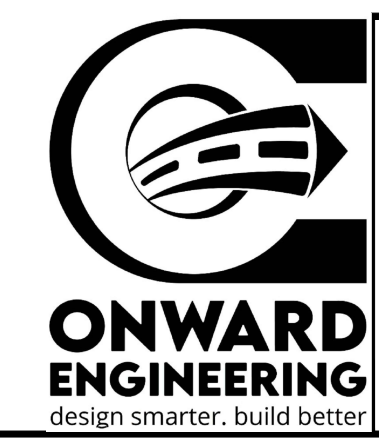

| | | | |
|--|--|---|---|
| CITY OF LA HABRA MONTE VISTA STREET STREET REHABILITATION LAMBERT RD. TO LA HABRA BLVD. | | DESIGNED BY: <i>Justin Sheets</i> JUSTIN SHEETS P.E. DATE: 03-20-2024 | PROJECT NO. 2-R-22 SHEET 07 OF 13 |
|--|--|---|---|

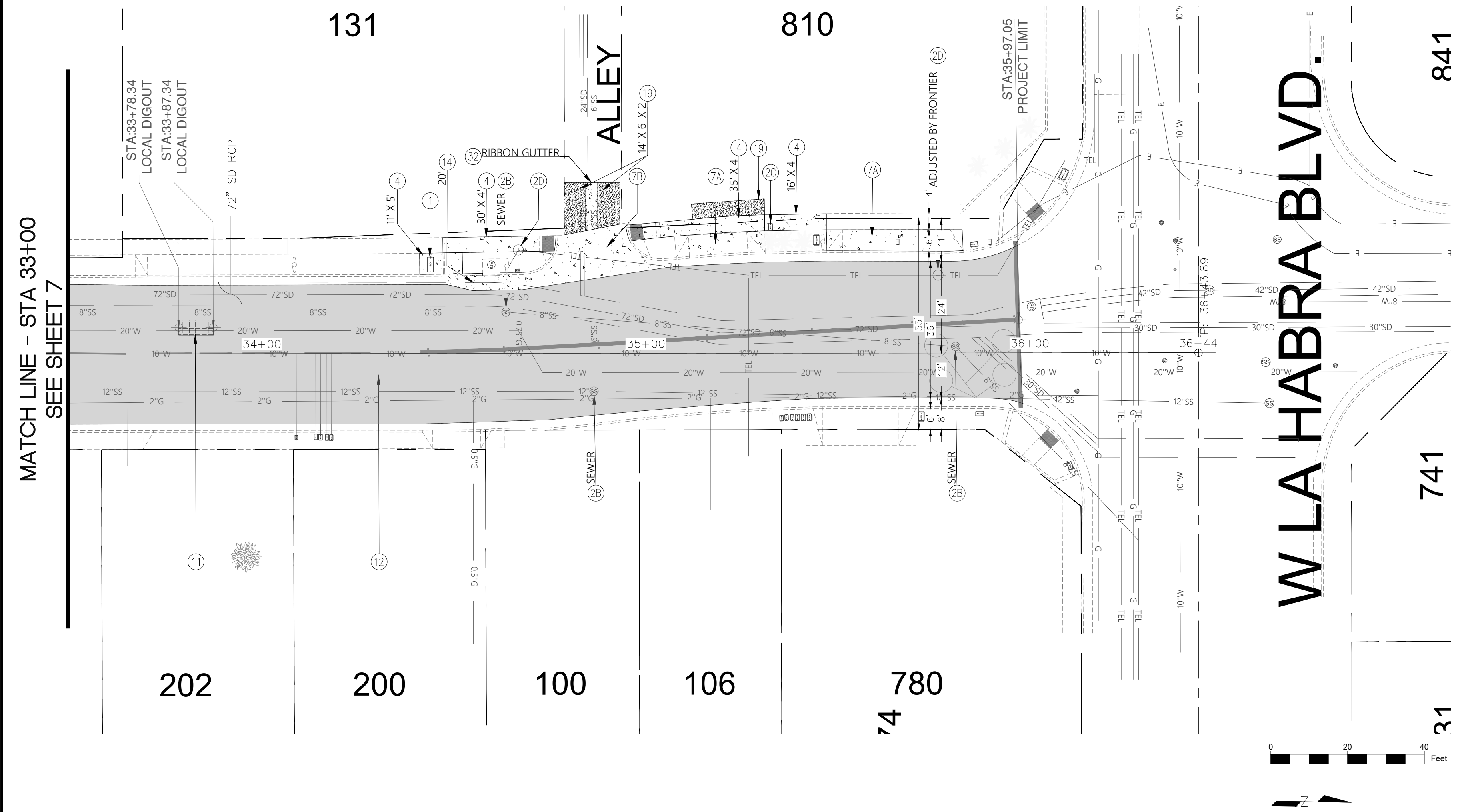

MATCH LINE - STA 33+00
SEE SHEET 7

NOTE
 SOCAL GAS - SOUTHERN CALIFORNIA GAS COMPANY: CONTRACTOR SHALL COORDINATE WITH SOUTHERN CALIFORNIA GAS COMPANY - KEITH BROWN - (840) 201-8017.
 LHHWCD - LA HABRA HEIGHTS COUNTY WATER DISTRICT: CONTRACTOR SHALL COORDINATE WITH LA HABRA HEIGHTS COUNTY WATER DISTRICT - (562) 665-0040
 OCFCD - ORANGE COUNTY FLOOD CONTROL DISTRICT: CONTRACTOR SHALL COORDINATE WITH OCFCD FOR MANHOLE ADJUSTMENTS ALEC GAMEZ - (714) 788-9829

LEGEND

| | |
|--|--|
| | CONCRETE IMPROVEMENTS. |
| | FULL DEPTH EXCAVATION 4" THICK C2 PG 64-10 WEARING COURSE TO MATCH NEW PCC SIDEWALK. |
| | TRUNCATED DOMES |
| | LOCALIZED DIGOUTS - REMOVE EXISTING 6" AC. RE-GRADE AND COMPACT BASE, PLACE 4" AC BASE COURSE AND THEN PLACE 2" AC ARHM OVERLAY. |
| | 2" COLD MILL AND PLACE 2" THICK ARHM WEARING COURSE. |
| | REMOVE EXISTING 6" AC. RE-GRADE AND COMPACT BASE, PLACE 4" AC BASE COURSE AND THEN PLACE 2" AC ARHM OVERLAY. |

CONSTRUCTION NOTES

- ① PROTECT IN PLACE ITEM AS NOTED ON PLAN.
- ②B ADJUST MANHOLE TO GRADE AS NOTED ON PLAN.
- ②C REPLACE PULL-BOX AS NOTED ON PLAN
- ②D ADJUST BY OTHERS. CONTRACTOR SHALL COORDINATE WITH RESPECTIVE UTILITIES.
- ④ SAWCUT AND REMOVE EXISTING SIDEWALK. CONSTRUCT NEW 4" THICK PCC SIDEWALK.
- ⑦A SAWCUT AND REMOVE EXISTING DRIVEWAY APPROACH. CONSTRUCT NEW PCC DRIVEWAY APPROACH PER SPPWC 110-2.
- ⑦B SAWCUT AND REMOVE EXISTING ALLEY INTERSECTION. CONSTRUCT NEW PCC ALLEY INTERSECTION PER SPPWC 130-3. CASE A OR B PER FIELD CONDITIONS.
- ⑪ LOCALIZED DIGOUTS - REMOVE EXISTING 6" AC. RE-GRADE AND COMPACT BASE. PLACE 4" AC BASE COURSE AND THEN PLACE 2" AC ARHM OVERLAY.
- ⑫ 2" COLD MILL AND PLACE 2" THICK ARHM-GG-C PG 64-16 WEARING COURSE.
- ⑭ SAW CUT AND REMOVE EXISTING LOCAL DEPRESSION. CONSTRUCT NEW PCC LOCAL DEPRESSION PER SPPWD STD PLAN 313-4.
- ⑰ FULL DEPTH EXCAVATION 4" AND PLACE 4" THICK C2 PG 64-10 WEARING COURSE TO MATCH NEW PCC SIDEWALK.
- ⑳ SAW CUT AND REMOVE EXISTING LONGITUDINAL GUTTER. CONSTRUCT NEW PCC LONGITUDINAL GUTTER PER SPPWC STANDARD PLAN 122-3.

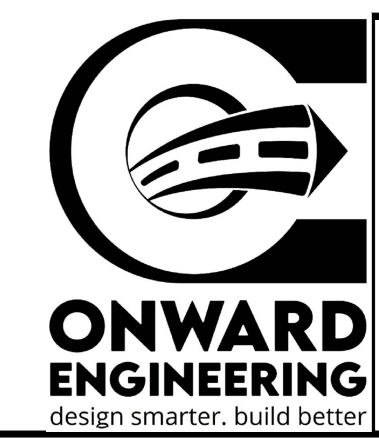

| | | | |
|--|--|---|---|
| CITY OF LA HABRA MONTE VISTA STREET STREET REHABILITATION LAMBERT RD. TO LA HABRA BLVD. | | DESIGNED BY: <i>Justin Sheets</i> JUSTIN SHEETS P.E. DATE: 03-20-2024 | PROJECT NO. 2-R-22 SHEET 08 of 13 |
|--|--|---|---|

866

W LAMBERT RD.

621

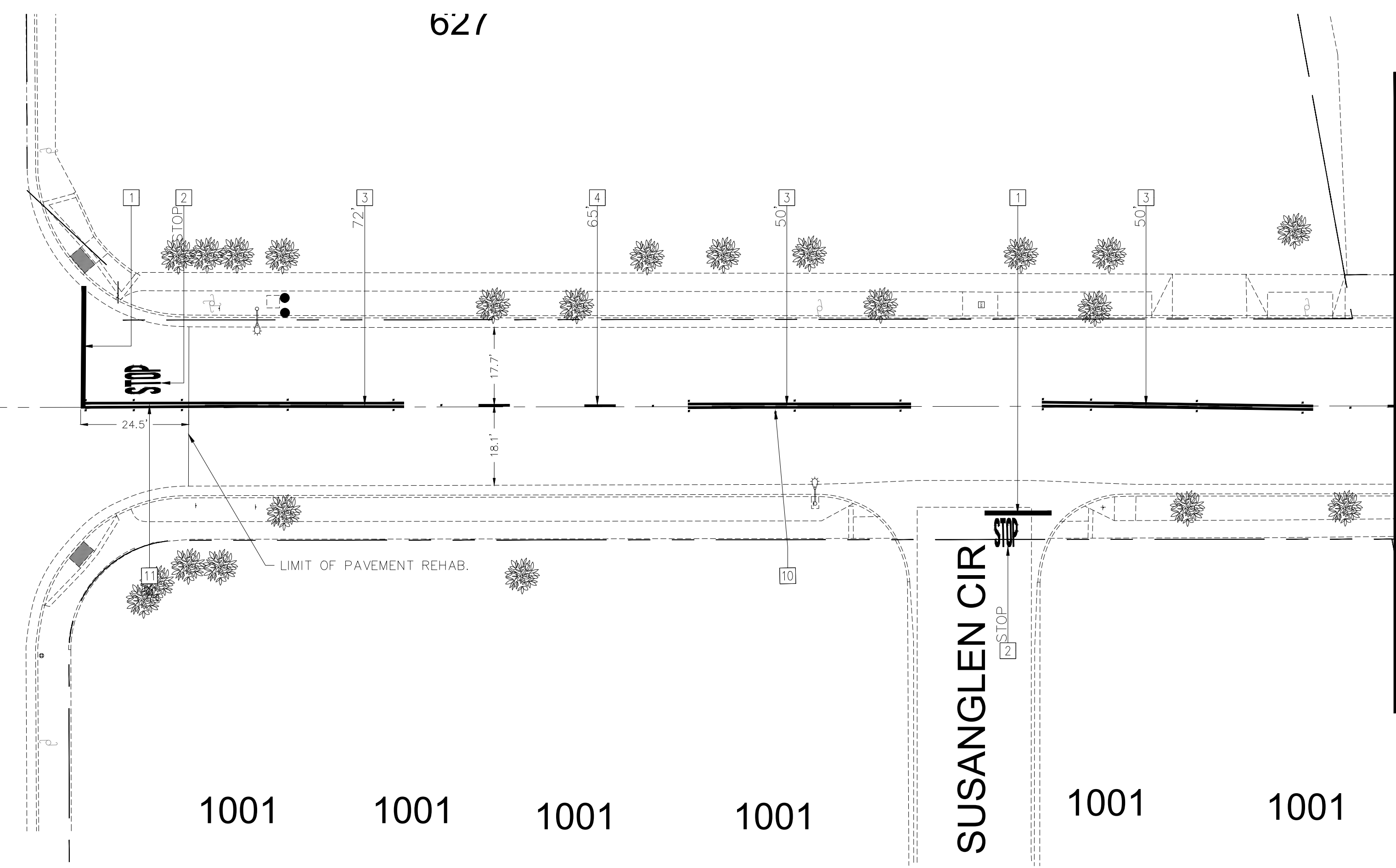

MATCH LINE - STA 13+50
SEE SHEET 10

STRIPING NOTES

- 1 INSTALL 12" WHITE LIMIT LINE PER CALTRANS STD PLAN A24G.
- 2 INSTALL WHITE PAVEMENT MARKINGS PER CALTRANS STD. A24D
- 3 INSTALL DOUBLE YELLOW PER CALTRANS STD. A20A, DETAIL 22.
- 4 INSTALL YELLOW CENTERLINE PER CALTRANS STD. A20A, DETAIL 2.
- 10 REPLACE BLUE (REFLECTIVE) RAISED PAVEMENT MARKER ADJACENT TO FIRE HYDRANTS IN ACCORDANCE WITH 2014 CAMUTCD. CLEAR VEGETATION FROM FIRE HYDRANT AS REQUIRED.
- 11 REMOVE EXISTING CENTERLINE STRIPING BY WET SAND BLASTING METHOD. INSTALL DOUBLE YELLOW PER CALTRANS STD. A20A, DETAIL 22.

- NOTES:
1. ALL PAINT SHALL BE TWO (2) COATS REGULAR PAINT. ALLOW AT LEAST SEVEN (7) DAYS BETWEEN COATS OF PAINT.
 2. CONTRACTOR SHALL VERIFY LOCATION OF ALL RAISED BLUE RETRO REFLECTIVE MARKERS PRIOR TO INSTALLATION
 3. IF SIDE STREET STOP LEGENDS DO NOT MATCH CALTRANS STD. A24D, CONTRACTOR SHALL TRY TO MATCH EXISTING STOP LEGEND MARKINGS AND REFRESH WITH TWO COATS OF PAINT 7 DAYS APART

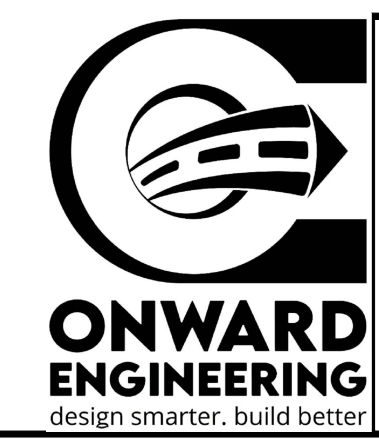

| | |
|--|-----------------------|
| CITY OF LA HABRA | |
| MONTE VISTA STREET STRIPING & SIGNING PLANS | |
| LAMBERT RD. TO LA HABRA BLVD. | |
| DESIGNED BY: <i>Justin Smeets</i> | PROJECT NO. 2-R-22 |
| DATE: 03-20-2024 | SHEET 09 of 13 |

MATCH LINE - STA 13+50
SEE SHEET 9

MATCH LINE - STA 20+00
SEE SHEET 11

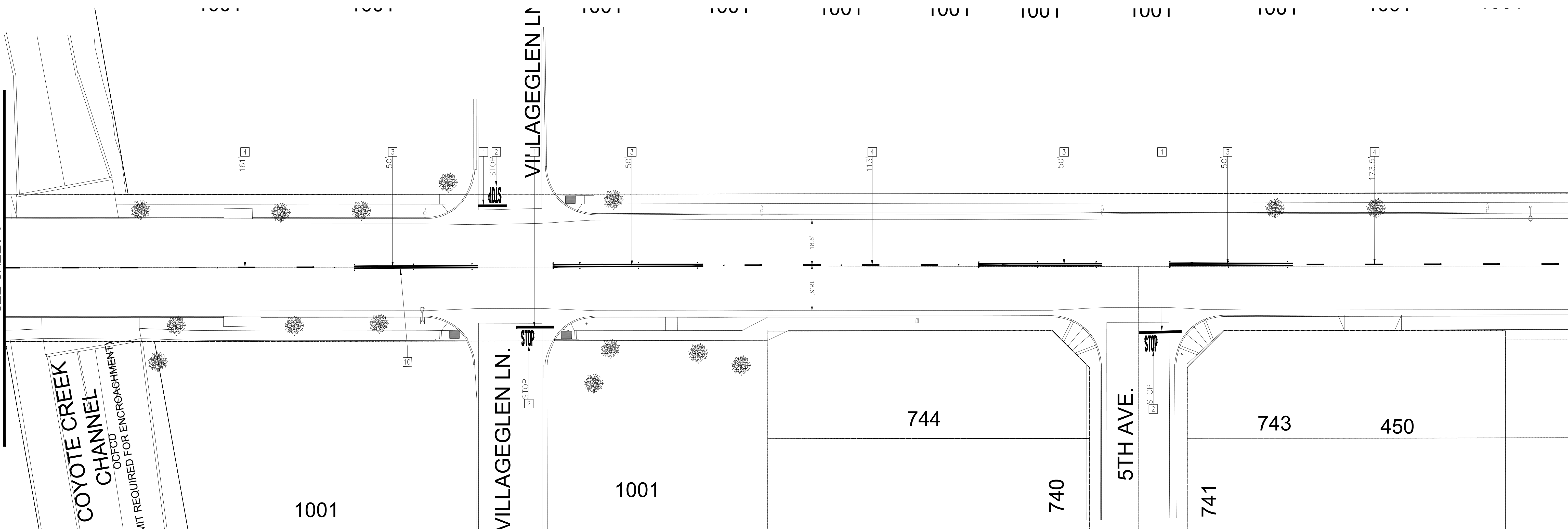

COYOTE CREEK
CHANNEL
CCFCD
MIT REQUIRED FOR ENCROACHMENT

VILLAGEGLEN LN.

5TH AVE.

1001

1001

744

740

741

743

450

STRIPING NOTES

- 1] INSTALL 12" WHITE LIMIT LINE PER CALTRANS STD PLAN A24G.
- 2] INSTALL WHITE PAVEMENT MARKINGS PER CALTRANS STD. A24D
- 3] INSTALL DOUBLE YELLOW PER CALTRANS STD. A20A, DETAIL 22.
- 4] INSTALL YELLOW CENTERLINE PER CALTRANS STD. A20A, DETAIL 2.
- 10] REPLACE BLUE (REFLECTIVE) RAISED PAVEMENT MARKER ADJACENT TO FIRE HYDRANTS IN ACCORDANCE WITH 2014 CAMUTCD. CLEAR VEGETATION FROM FIRE HYDRANT AS REQUIRED.

- NOTES:
- 1. ALL PAINT SHALL BE TWO (2) COATS REGULAR PAINT. ALLOW AT LEAST SEVEN (7) DAYS BETWEEN COATS OF PAINT.
 - 2. CONTRACTOR SHALL VERIFY LOCATION OF ALL RAISED BLUE RETRO REFLECTIVE MARKERS PRIOR TO INSTALLATION
 - 3. IF SIDE STREET STOP LEGENDS DO NOT MATCH CALTRANS STD. A24D, CONTRACTOR SHALL TRY TO MATCH EXISTING STOP LEGEND MARKINGS AND REFRESH WITH TWO COATS OF PAINT 7 DAYS APART

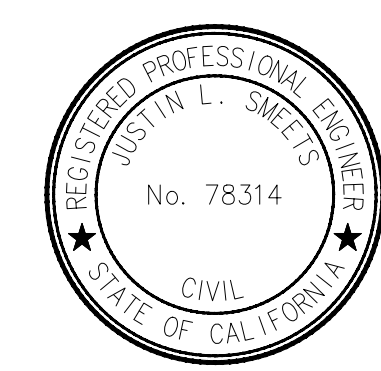
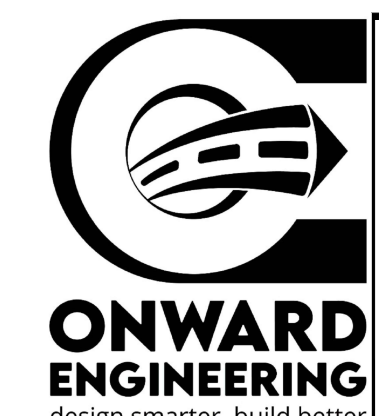

| | |
|--|-----------------------|
| CITY OF LA HABRA | |
| MONTE VISTA STREET STRIPING & SIGNING PLANS | |
| LAMBERT RD. TO LA HABRA BLVD. | |
| DESIGNED BY: <i>Justin Sheets</i> | PROJECT NO. 2-R-22 |
| DATE: 03-20-2024 | SHEET 10 OF 13 |

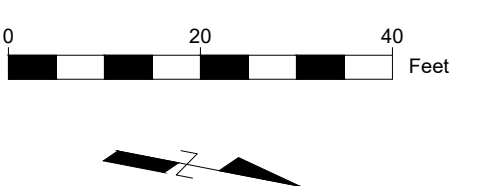
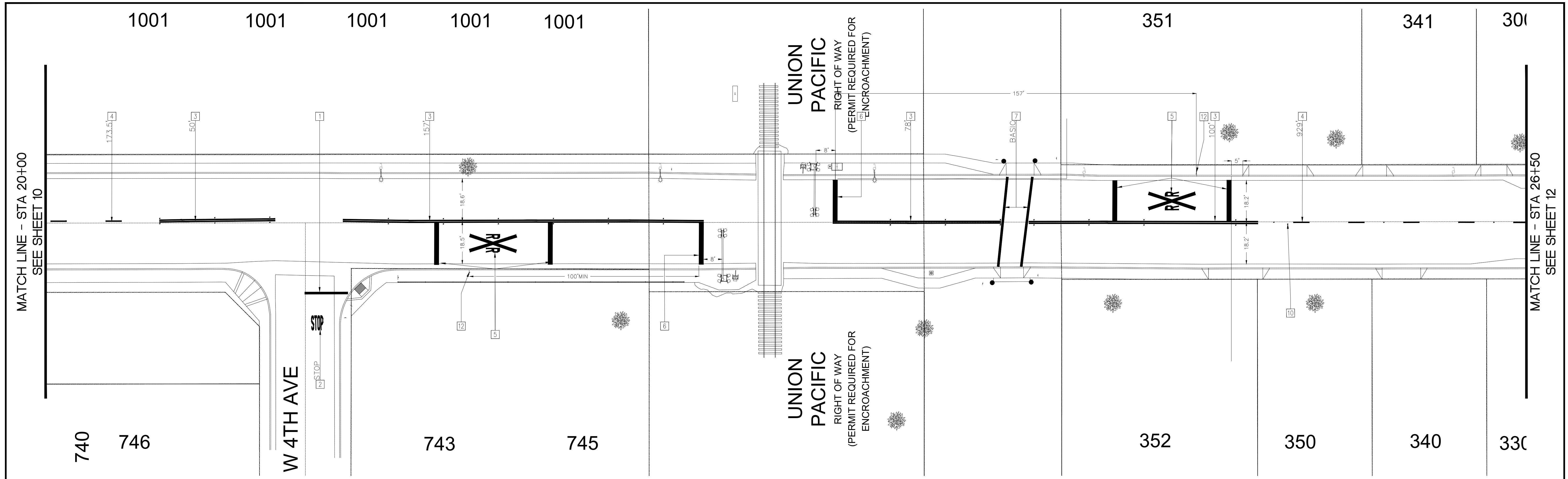

STRIPING NOTES

- 1] INSTALL 12" WHITE LIMIT LINE PER CALTRANS STD PLAN A24G.
- 2] INSTALL WHITE PAVEMENT MARKINGS PER CALTRANS STD. A24D
- 3] INSTALL DOUBLE YELLOW PER CALTRANS STD. A20A, DETAIL 22.
- 4] INSTALL YELLOW CENTERLINE PER CALTRANS STD. A20A, DETAIL 2.
- 5] INSTALL RAILROAD CROSSING SYMBOL MARKINGS WITH 2' WIDE TRANSVERSE LINES PER CALTRANS STD. PLAN, A24B.
- 6] INSTALL 2' WIDE LIMIT LINE PER CALTRANS STD. PLAN A24B FOR RAILROAD CROSSINGS.
- 7] INSTALL WHITE CROSSWALK PER CALTRANS STD. PLAN A24F. CROSSWALK WIDTH TO BE DETERMINED BY ENGINEER IN FIELD.
- 10] REPLACE BLUE (REFLECTIVE) RAISED PAVEMENT MARKER ADJACENT TO FIRE HYDRANTS IN ACCORDANCE WITH 2014 CAMUTCD. CLEAR VEGETATION FROM FIRE HYDRANT AS REQUIRED.
- 12] INSTALL W10-1 PER CAMUTCD ON NEW TELESPAR POST. AS DIRECTED BY CITY IN FIELD.

- NOTES:
- 1. ALL PAINT SHALL BE TWO (2) COATS REGULAR PAINT. ALLOW AT LEAST SEVEN (7) DAYS BETWEEN COATS OF PAINT.
 - 2. CONTRACTOR SHALL VERIFY LOCATION OF ALL RAISED BLUE RETRO REFLECTIVE MARKERS PRIOR TO INSTALLATION
 - 3. IF SIDE STREET STOP LEGENDS DO NOT MATCH CALTRANS STD. A24D. CONTRACTOR SHALL MATCH EXISTING STOP LEGEND MARKINGS AND REFRESH WITH TWO COATS OF PAINT 7 DAYS APART

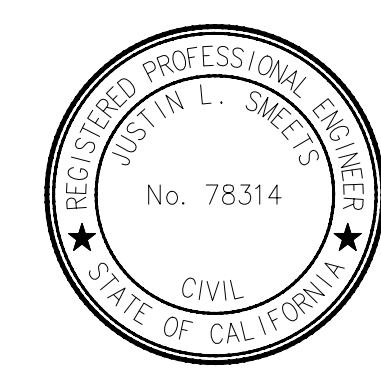
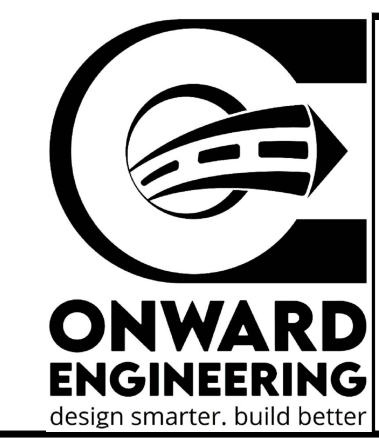

| | |
|--|-----------------------|
| CITY OF LA HABRA | |
| MONTE VISTA STREET STRIPING & SIGNING PLANS | |
| LAMBERT RD. TO LA HABRA BLVD. | |
| DESIGNED BY: <i>Justin Sheets</i> | PROJECT NO. 2-R-22 |
| DATE: 03-20-2024 | SHEET 11 of 13 |

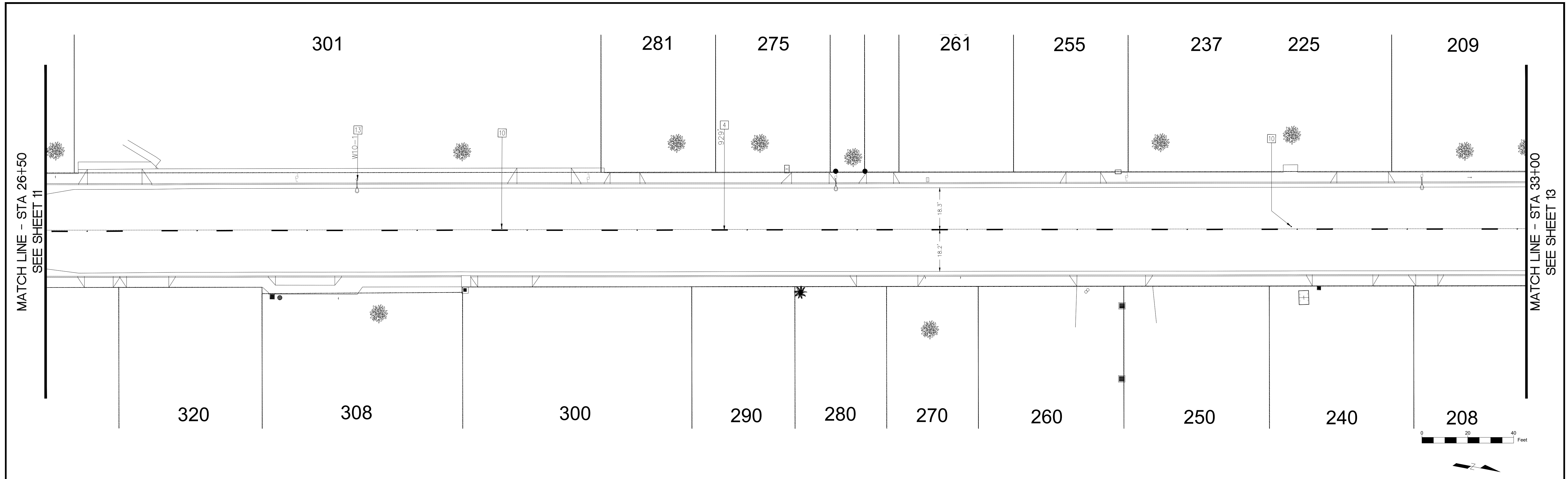

- STRIPING NOTES**
- 4 INSTALL YELLOW CENTERLINE PER CALTRANS STD. A20A, DETAIL 2.
 - 10 REPLACE BLUE (REFLECTIVE) RAISED PAVEMENT MARKER ADJACENT TO FIRE HYDRANTS IN ACCORDANCE WITH 2014 CAMUTCD. CLEAR VEGETATION FROM FIRE HYDRANT AS REQUIRED.
 - 13 REMOVE AND DISPOSE OF EXISTING SIGN PER PLAN.

- NOTES:**
1. ALL PAINT SHALL BE TWO (2) COATS REGULAR PAINT. ALLOW AT LEAST SEVEN (7) DAYS BETWEEN COATS OF PAINT.
 2. CONTRACTOR SHALL VERIFY LOCATION OF ALL RAISED BLUE RETRO REFLECTIVE MARKERS PRIOR TO INSTALLATION
 3. IF SIDE STREET STOP LEGENDS DO NOT MATCH CALTRANS STD. A24D, CONTRACTOR SHALL TRY TO MATCH EXISTING STOP LEGEND MARKINGS AND REFRESH WITH TWO COATS OF PAINT 7 DAYS APART

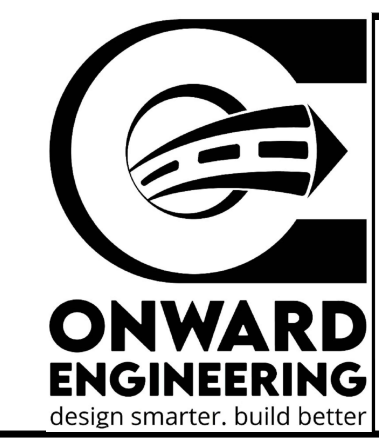

| | | | |
|--------------|----------------------|--|----------|
| | | CITY OF LA HABRA | |
| | | MONTE VISTA STREET STRIPING & SIGNING PLANS | |
| | | LAMBERT RD. TO LA HABRA BLVD. | |
| DESIGNED BY: | <i>Justin Smeets</i> | PROJECT NO. | 2-R-22 |
| DATE | 03-20-2024 | SHEET | 12 OF 13 |

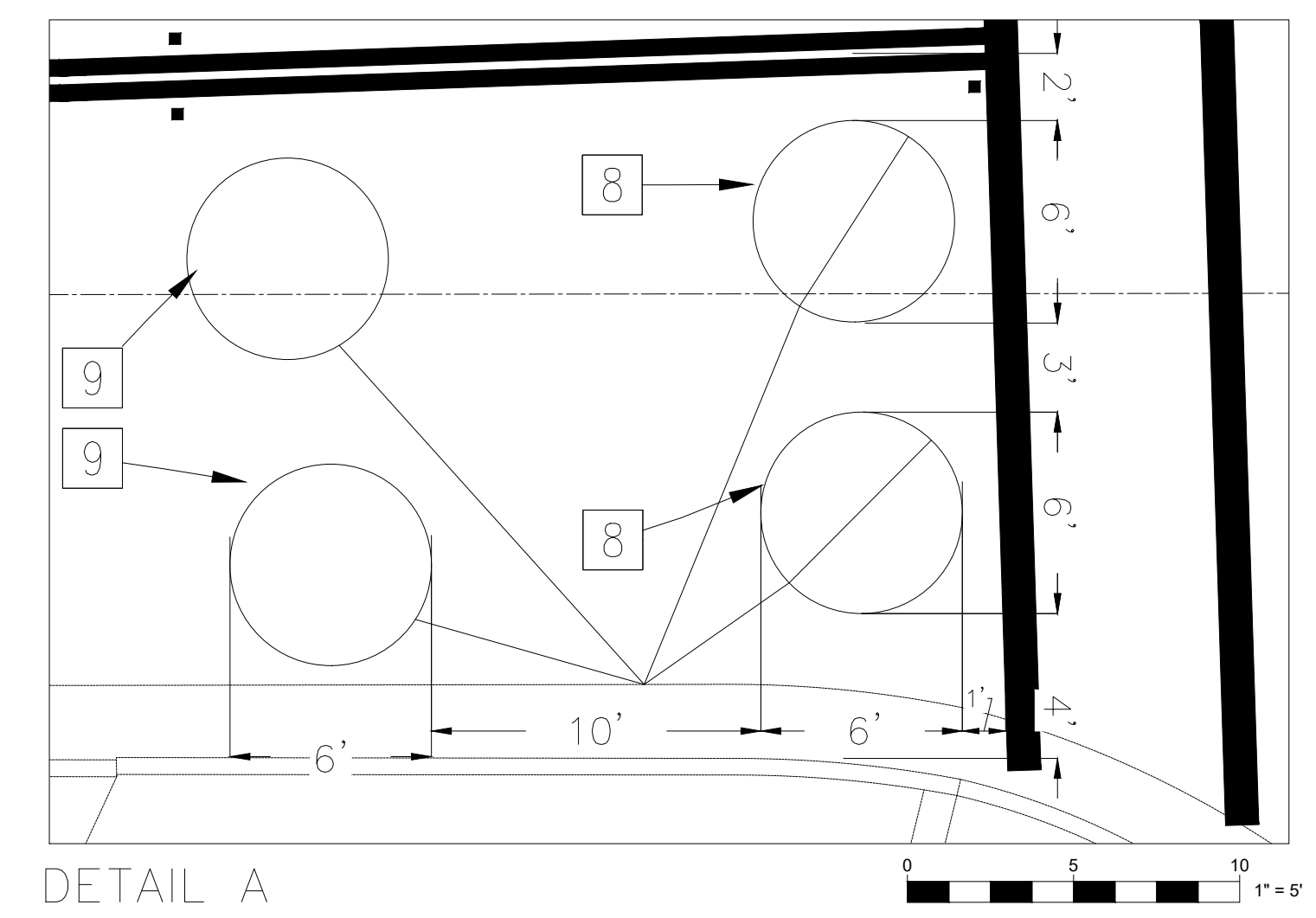
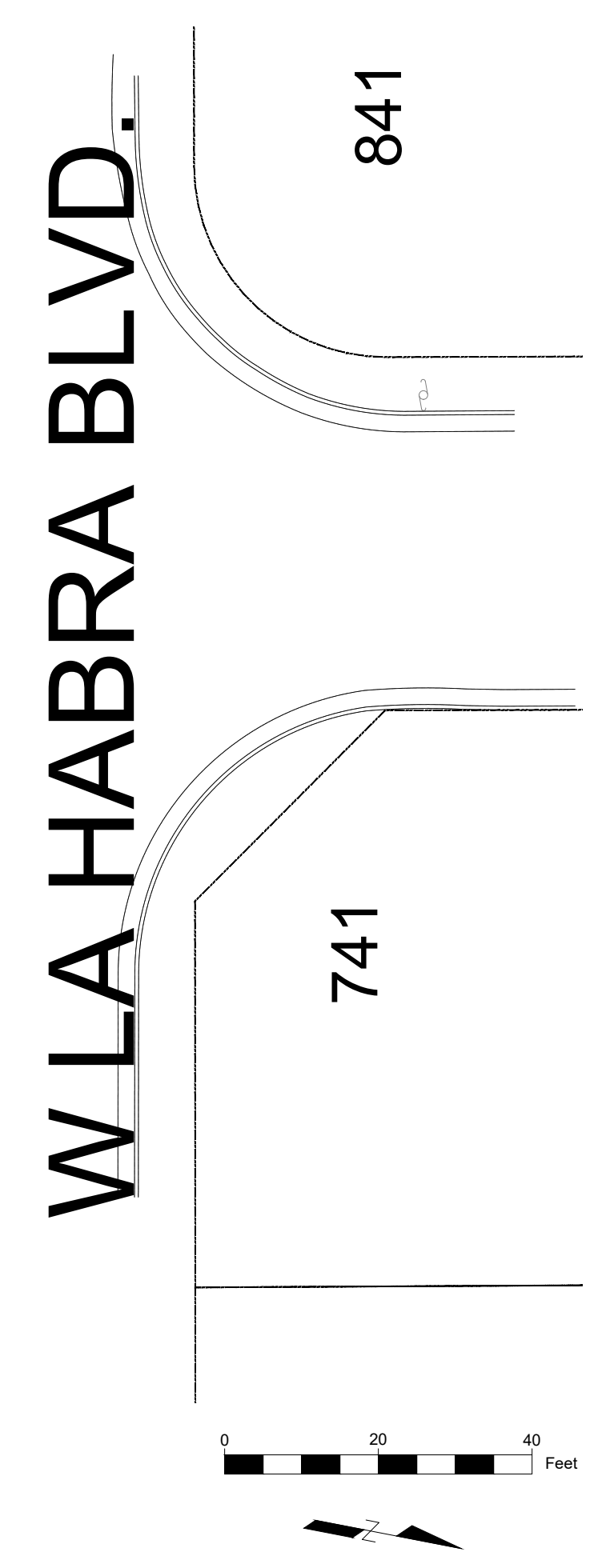
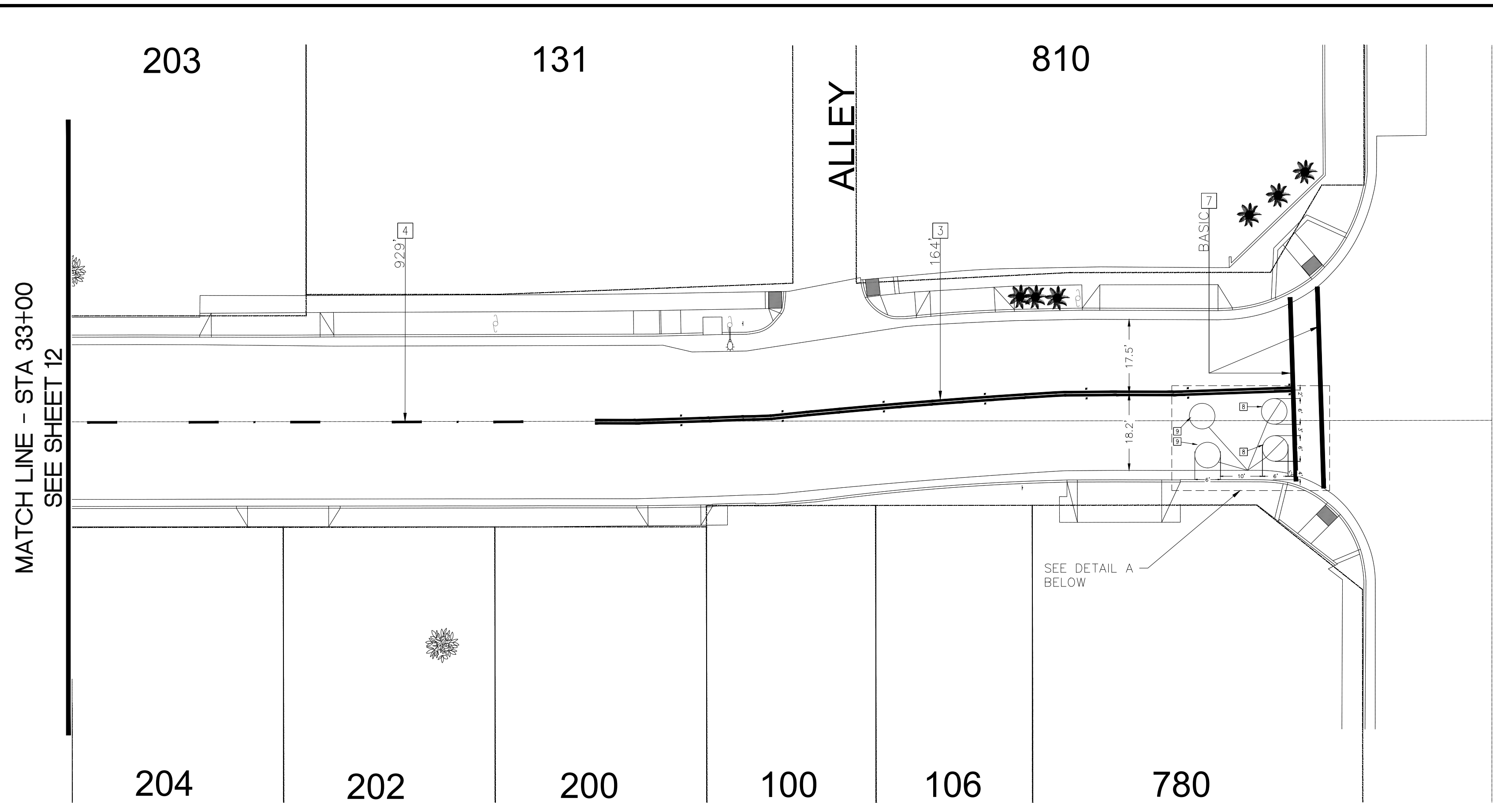

- NOTES:
- ALL PAINT SHALL BE TWO (2) COATS REGULAR PAINT. ALLOW AT LEAST SEVEN (7) DAYS BETWEEN COATS OF PAINT.
 - CONTRACTOR SHALL VERIFY LOCATION OF ALL RAISED BLUE RETRO REFLECTIVE MARKERS PRIOR TO INSTALLATION
 - IF SIDE STREET STOP LEGENDS DO NOT MATCH CALTRANS STD. A24D, CONTRACTOR SHALL TRY TO MATCH EXISTING STOP LEGEND MARKINGS AND REFRESH WITH TWO COATS OF PAINT 7 DAYS APART

- STRIPING NOTES
- INSTALL DOUBLE YELLOW PER CALTRANS STD. A20A, DETAIL 22.
 - INSTALL YELLOW CENTERLINE PER CALTRANS STD. A20A, DETAIL 2.
 - INSTALL WHITE CROSSWALK PER CALTRANS STD. PLAN A24F. CROSSWALK WIDTH TO BE DETERMINED BY ENGINEER IN FIELD.
 - INSTALL TYPE F (BICYCLE) LOOP DETECTOR PER CALTRANS STD., RSP ES-5B.
 - INSTALL TYPE E LOOP DETECTOR PER CALTRANS STD. RSP ES-5B.

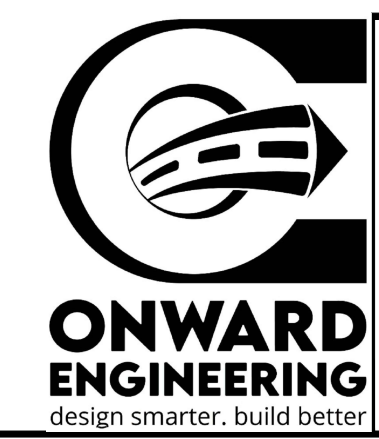

| | |
|--|--------------------|
| CITY OF LA HABRA | |
| MONTE VISTA STREET STRIPING & SIGNING PLANS | |
| LAMBERT RD. TO LA HABRA BLVD. | |
| DESIGNED BY: <i>Justin Sheets</i> | PROJECT NO. 2-R-22 |
| DATE: 03-20-2024 | SHEET 13 OF 13 |

APPENDIX “B”

STANDARD DETAILS

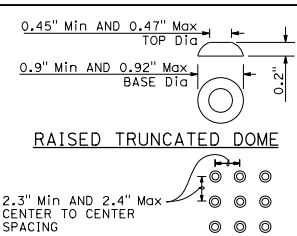
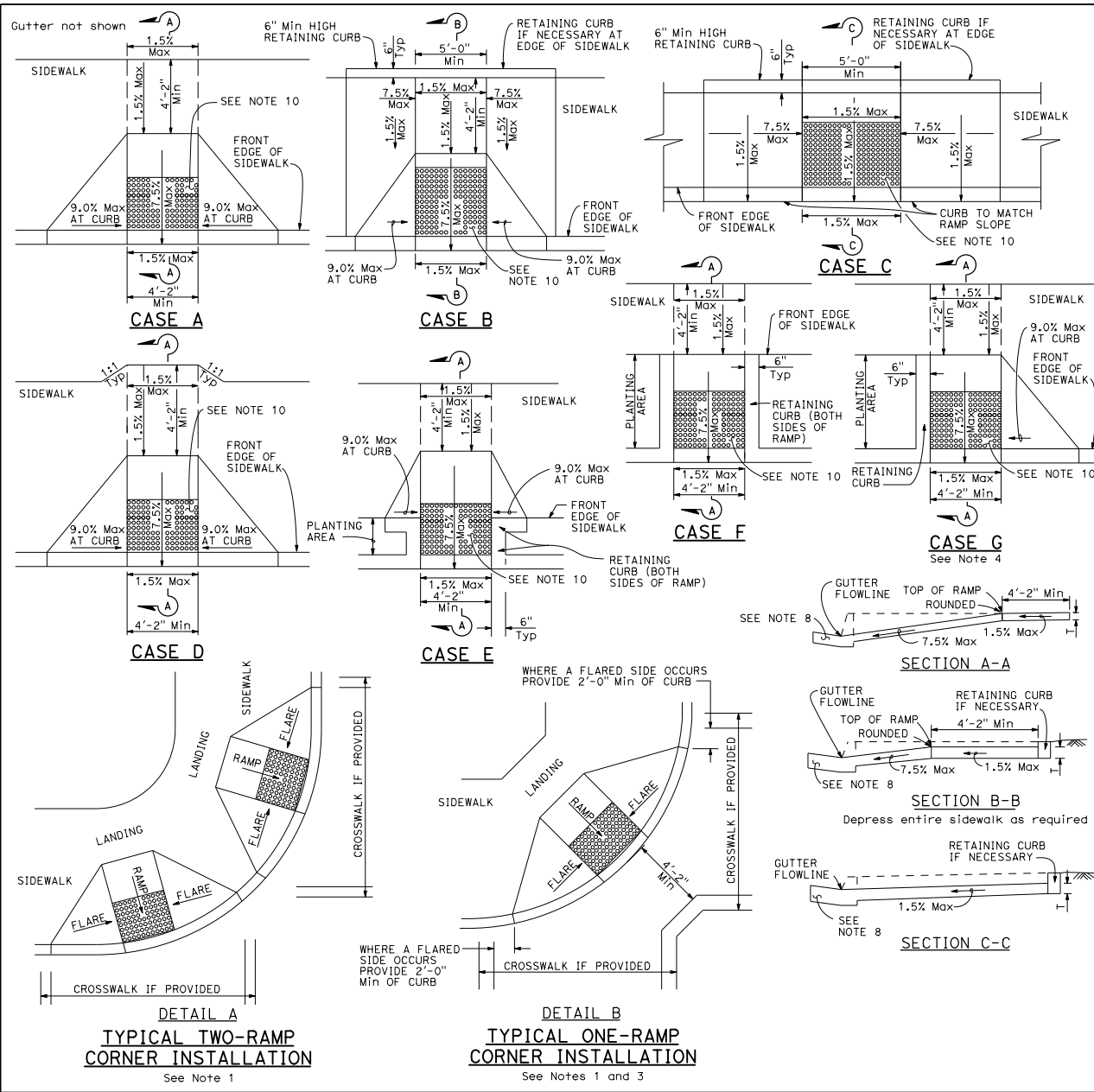

RAISED TRUNCATED DOME PATTERN (IN-LINE) DETECTABLE WARNING SURFACE

- NOTES:** See Note 10
- As site conditions dictate, Case A through Case G curb ramps may be used for corner installations similar to those shown in Detail A and Detail B. The case of curb ramps used in Detail A do not have to be the same. Case A through Case G curb ramps also may be used at mid block locations, as site conditions dictate. For specific site condition configuration, including the conform to existing sidewalk, see Project Plans.
 - If distance from curb to back of sidewalk is too short to accommodate ramp and 4'-2" platform (landing) as shown in Case A, the sidewalk may be depressed longitudinally as in Case B or C or may be widened as in Case D.
 - When ramp is located in center of curb return, crosswalk configuration must be similar to that shown for Detail B.
 - As site conditions dictate, the retaining curb side and the flared side of the Case G ramp shall be constructed in reversed position.
 - The ramp portion of the curb ramp is a typical rectangle, unless modified in the Project Plans.
 - Side slope of ramp flares vary uniformly from a maximum of 9.0% at curb to conform with longitudinal sidewalk slope adjacent to top of the ramp, except in Case C and Case F.
 - The adjacent surfaces at transitions at curb ramps to walks, gutters, and streets shall be at the same level.
 - Counter slopes of adjoining gutters and road surfaces immediately adjacent to and within 24 inches of the curb ramp shall not be steeper than 1V:20H (5.0%). Gutter pan slope shall not exceed 1" of depth for each 2'-0" of width.
 - Transition gutter pan slope from 1" of depth for each 2'-0" of width to match typical gutter pan slope per Standard Plan A87A.
 - The detectable warning surface will be a rectangle as shown at back of curb, unless modified in the Project Plans. Curb ramps shall have a detectable warning surface that extends the full width and 3'-0" depth of the ramp. Detectable warning surfaces shall extend the full width of the ramp except a maximum gap of 1 inch is allowed on each side of the ramp. Detectable warning surfaces shall conform to the requirements in the Standard Specifications.
 - Sidewalk and ramp thickness, "T", shall be 3/2" minimum.
 - Utility pull boxes, manholes, vaults and all other utility facilities within the boundaries of the curb ramp will be relocated or adjusted to grade by the owner prior to, or in conjunction with, curb ramp construction.
 - Detectable warning surface may have to be cut to allow removal of utility covers while maintaining detectable warning width and depth.

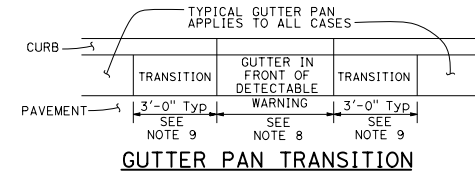

STATE OF CALIFORNIA
DEPARTMENT OF TRANSPORTATION
CURB RAMP DETAILS
NO SCALE

A88A

| | | | | | |
|------|--------|-------|--------------------------|-----------|--------------|
| DIST | COUNTY | ROUTE | POST MILES TOTAL PROJECT | SHEET NO. | TOTAL SHEETS |
| | | | | | |

REGISTERED CIVIL ENGINEER
Rebecca Lynn Moory
No. C54415
Exp. 12-31-19
CIVIL
REGISTERED PROFESSIONAL ENGINEER
STATE OF CALIFORNIA

May 31, 2018
PLANS APPROVAL DATE
THE STATE OF CALIFORNIA OR ITS OFFICERS OR AGENTS SHALL NOT BE RESPONSIBLE FOR THE ACCURACY OR COMPLETENESS OF SCANNED COPIES OF THIS PLAN SHEET.

CENTERLINES (2 LANE HIGHWAYS)

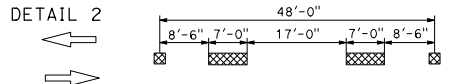
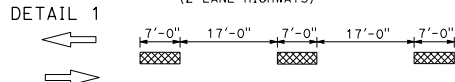

~~DETAIL 3~~ DETAIL 3 DELETED

~~DETAIL 4~~ DETAIL 4 DELETED

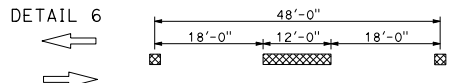
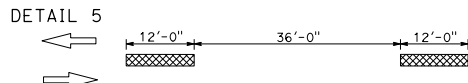

~~DETAIL 7~~ DETAIL 7 DELETED

LANELINES (MULTILANE HIGHWAYS)

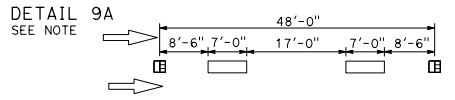
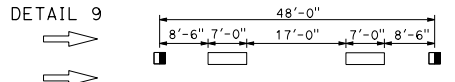
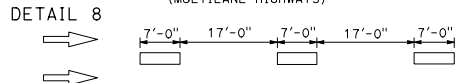

~~DETAIL 10~~ DETAIL 10 DELETED

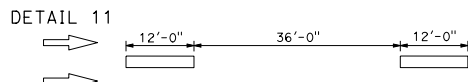

LANELINES (Cont) (MULTILANE HIGHWAYS)

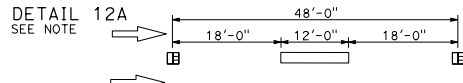
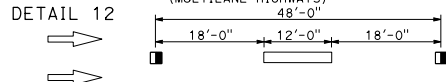

~~DETAIL 13~~ DETAIL 13 DELETED

~~DETAIL 14~~ DETAIL 14 DELETED

~~DETAIL 14A~~ DETAIL 14A DELETED

NO PASSING ZONES-ONE DIRECTION

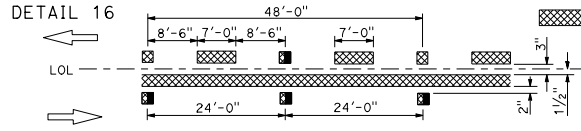
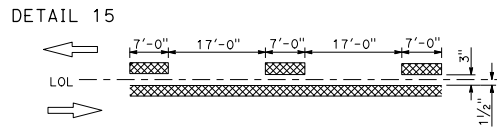

~~DETAIL 17~~ DETAIL 17 DELETED

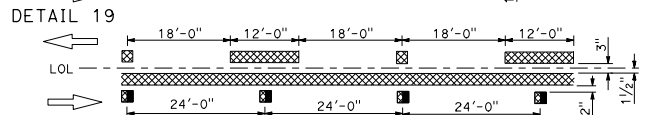
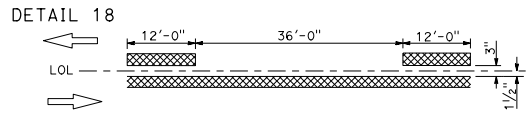

~~DETAIL 20~~ DETAIL 20 DELETED

NO PASSING ZONES-TWO DIRECTION

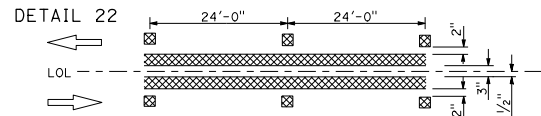
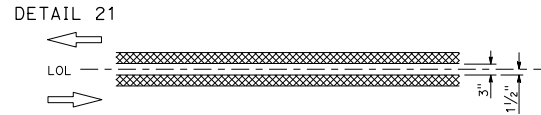

~~DETAIL 23~~ DETAIL 23 DELETED

LEGEND

MARKERS

- TYPE C RED-CLEAR RETROREFLECTIVE
- TYPE D TWO-WAY YELLOW RETROREFLECTIVE
- TYPE G ONE-WAY CLEAR RETROREFLECTIVE
- TYPE H ONE-WAY YELLOW RETROREFLECTIVE

LINES

- 6" WHITE
- 6" YELLOW

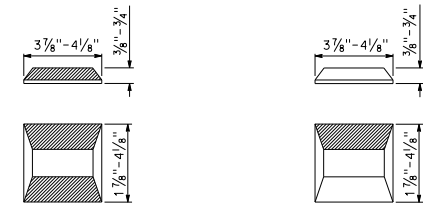

TYPE C AND TYPE D TYPE G AND TYPE H

RETROREFLECTIVE FACE

STATE OF CALIFORNIA
DEPARTMENT OF TRANSPORTATION

PAVEMENT MARKERS AND TRAFFIC LINES TYPICAL DETAILS

NO SCALE

A20A

| | | | | | |
|------|--------|-------|-----------------------------|-----------|--------------|
| DIST | COUNTY | ROUTE | POST MILES TOTAL PROJECT | SHEET NO. | TOTAL SHEETS |
| | | | | | |

Atifa Ferouz
REGISTERED CIVIL ENGINEER

May 31, 2018
PLANS APPROVAL DATE

Atifa Ferouz
No. C80402
EXP. 3-31-19
CIVIL
STATE OF CALIFORNIA

THE STATE OF CALIFORNIA OR ITS OFFICERS OR AGENTS SHALL NOT BE RESPONSIBLE FOR THE ACCURACY OR COMPLETENESS OF SCANNED COPIES OF THIS PLAN SHEET.

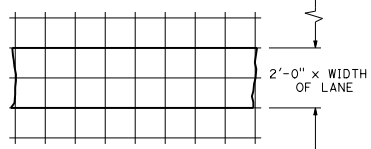
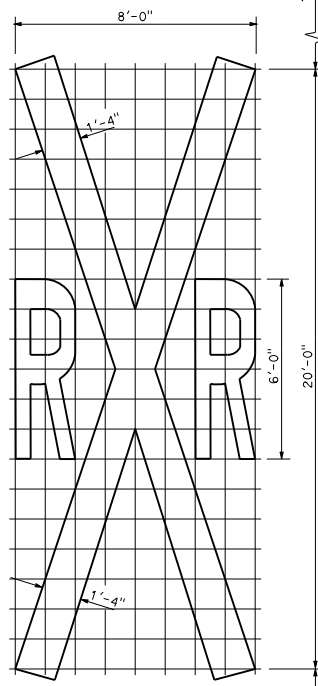
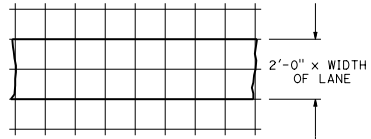

RAILROAD CROSSING SYMBOL

* 70 ft² does not include the 2'-0" x variable width transverse lines.

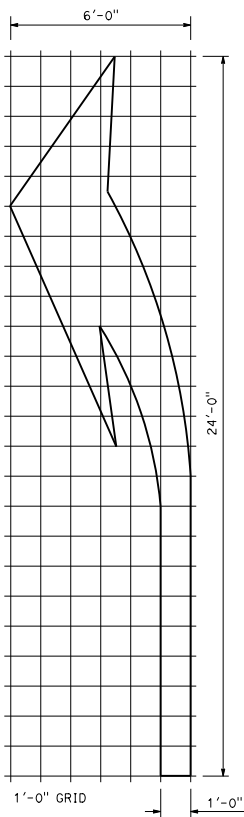

A=42 ft²
TYPE III (L) ARROW
(For Type III (R) use mirror image)

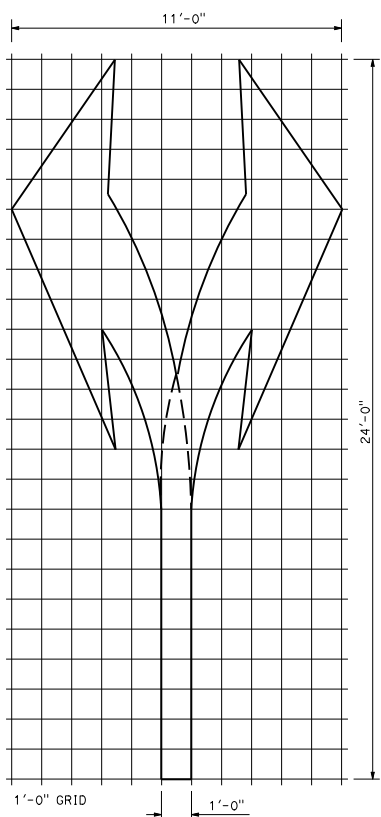

A=73 ft²
TYPE III (B) ARROW

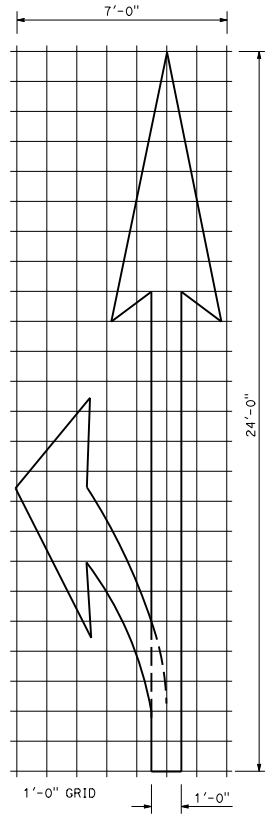

A=45 ft²
TYPE II (L) ARROW
(For Type II (R) use mirror image)

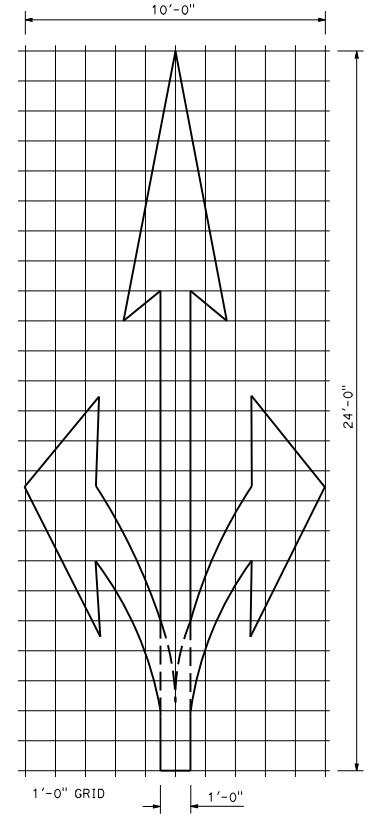

A=59 ft²
TYPE II (B) ARROW

NOTE:
Minor variations in dimensions may be accepted by the Engineer.

STATE OF CALIFORNIA
DEPARTMENT OF TRANSPORTATION
**PAVEMENT MARKINGS
ARROWS AND SYMBOLS**
NO SCALE

A 24B

| DIST. | COUNTY | ROUTE | POST MILES TOTAL PROJECT | SHEET NO. | TOTAL SHEETS |
|-------|--------|-------|--------------------------|-----------|--------------|
| | | | | | |

Atifa Ferouz
REGISTERED CIVIL ENGINEER

PLANS APPROVAL DATE
May 31, 2018

REGISTERED PROFESSIONAL ENGINEER
Atifa Ferouz
No. C80402
Exp. 3-31-19
CIVIL
STATE OF CALIFORNIA

THE STATE OF CALIFORNIA OR ITS OFFICERS OR AGENTS SHALL NOT BE RESPONSIBLE FOR THE ACCURACY OR COMPLETENESS OF SCANNED COPIES OF THIS PLAN SHEET.

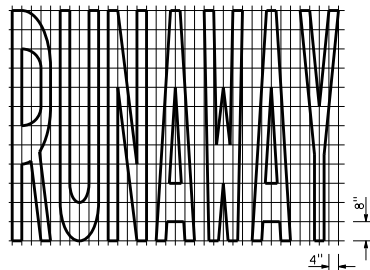

A=43 f+2

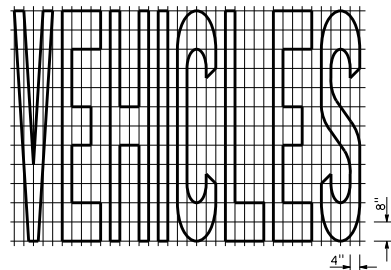

A=42 f+2

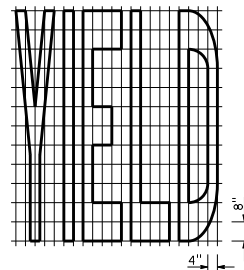

A=24 f+2

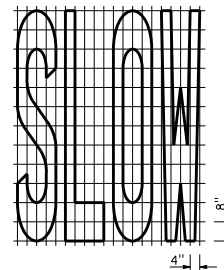

A=23 f+2

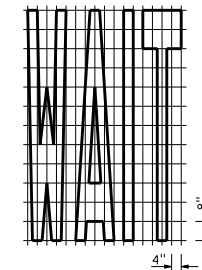

A=19 f+2

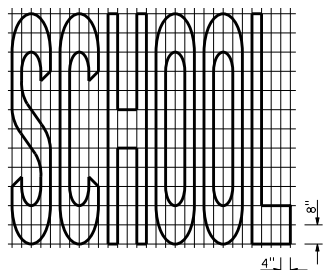

A=35 f+2

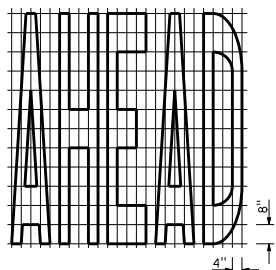

A=31 f+2

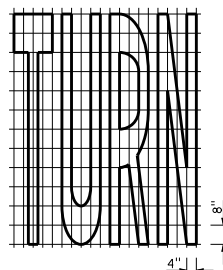

A=24 f+2

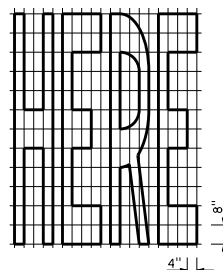

A=26 f+2

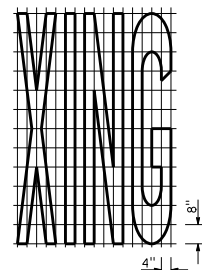

A=21 f+2

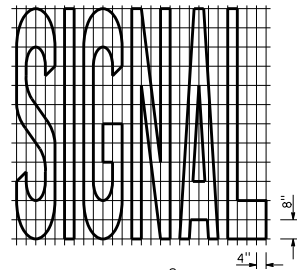

A=32 f+2

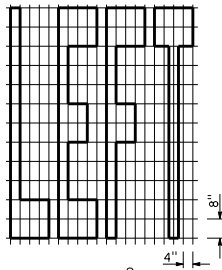

A=19 f+2

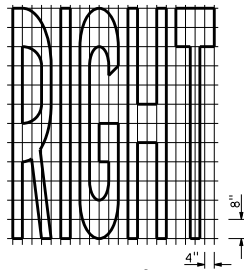

A=26 f+2

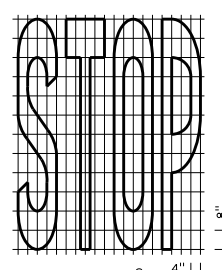

A=22 f+2

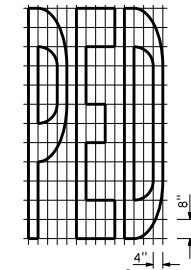

A=18 f+2

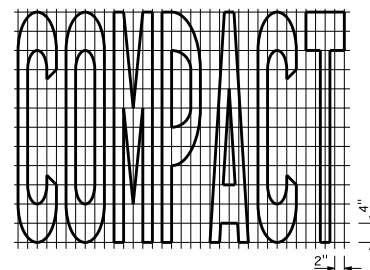

A=10 f+2

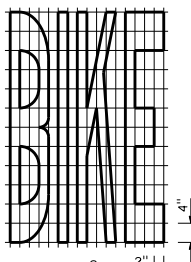

A=5 f+2

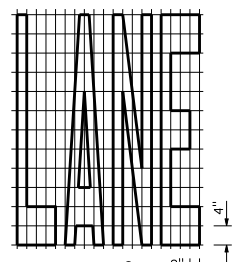

A=6 f+2

| | | | | |
|------|--------|-------|--------------------------|--------------------|
| DIST | COUNTY | ROUTE | POST MILES TOTAL PROJECT | SHEET TOTAL SHEETS |
| | | | | |

Atifa Ferouz
REGISTERED CIVIL ENGINEER

May 31, 2018
PLANS APPROVAL DATE

Atifa Ferouz
No. C80402
Exp. 3-31-19
CIVIL
REGISTERED PROFESSIONAL ENGINEER
STATE OF CALIFORNIA

THE STATE OF CALIFORNIA OR ITS OFFICERS OR AGENTS SHALL NOT BE RESPONSIBLE FOR THE ACCURACY OR COMPLETENESS OF SCANNED COPIES OF THIS PLAN SHEET.

NOTES:

1. If a message consists of more than one word, it must read "UP", i.e., the first word must be nearest the driver.
2. The space between words must be at least four times the height of the characters for low speed roads, but not more than ten times the height of the characters. The space may be reduced appropriately where there is limited space because of local conditions.
3. Minor variations in dimensions may be accepted by the Engineer.
4. Portions of a letter, number or symbol may be separated by connecting segments not to exceed 2" in width.

| WORD MARKINGS | | | | | |
|---------------|-----|--------|-----|----------|-----|
| ITEM | f+2 | ITEM | f+2 | ITEM | f+2 |
| XING | 21 | YIELD | 24 | BIKE | 5 |
| AHEAD | 31 | SCHOOL | 35 | SLOW | 23 |
| WAIT | 19 | SIGNAL | 32 | STOP | 22 |
| LANE | 6 | TURN | 24 | LEFT | 19 |
| RIGHT | 26 | HERE | 26 | VEHICLES | 42 |

STATE OF CALIFORNIA
DEPARTMENT OF TRANSPORTATION
**PAVEMENT MARKINGS
WORDS**

NO SCALE

A 24D

| Dist | County | Route | Post Miles Total Project | Sheet No. | Total Sheets |
|--|--------|-------|-----------------------------|--------------|-----------------|
| | | | | | |
| <i>Atifa Ferouz</i> REGISTERED CIVIL ENGINEER | | | | | |
| May 31, 2018 PLANS APPROVAL DATE | | | | | |
| THE STATE OF CALIFORNIA OR ITS OFFICERS OR AGENTS SHALL NOT BE RESPONSIBLE FOR THE ACCURACY OR COMPLETENESS OF SCANNED COPIES OF THIS PLAN SHEET. | | | | | |

REGISTERED PROFESSIONAL ENGINEER
Atifa Ferouz
 No. C80402
 Exp. 3-31-19
 CIVIL
 STATE OF CALIFORNIA

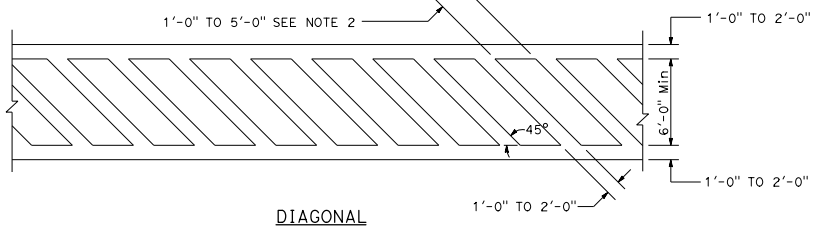
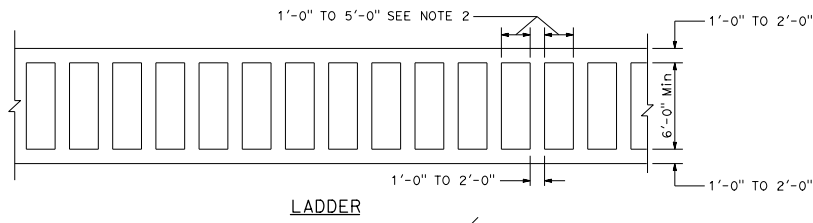
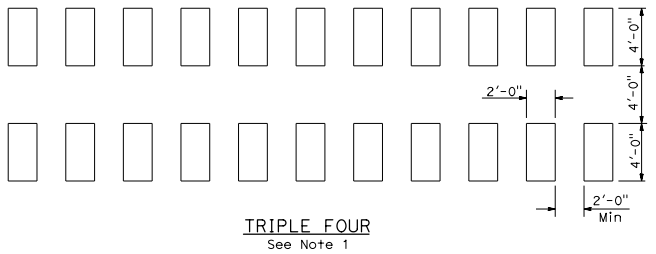
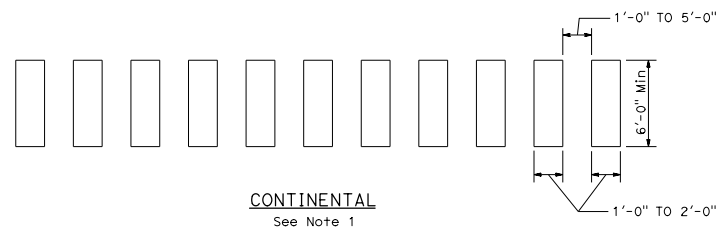

HIGHER VISIBILITY CROSSWALKS

NOTES:

1. Spaces between markings must be placed in wheel tracks of each lane.
2. Spacings not to exceed 2.5 times width of longitudinal line.
3. All crosswalk markings must be white except those near schools must be yellow.

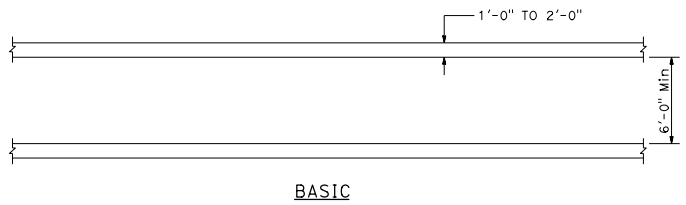

STATE OF CALIFORNIA
DEPARTMENT OF TRANSPORTATION
**PAVEMENT MARKINGS
CROSSWALKS**
NO SCALE

A 24F

| DIST | COUNTY | ROUTE | POST MILES TOTAL PROJECT | SHEET No. | TOTAL SHEETS |
|------|--------|-------|-----------------------------|--------------|-----------------|
| | | | | | |

Atifa Ferouzi
REGISTERED CIVIL ENGINEER

October 19, 2018
PLANS APPROVAL DATE

THE STATE OF CALIFORNIA OR ITS OFFICERS
OR AGENTS SHALL NOT BE RESPONSIBLE FOR
THE ACCURACY OR COMPLETENESS OF SCANNED
COPIES OF THIS PLAN SHEET.

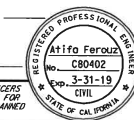

TO ACCOMPANY PLANS DATED _____

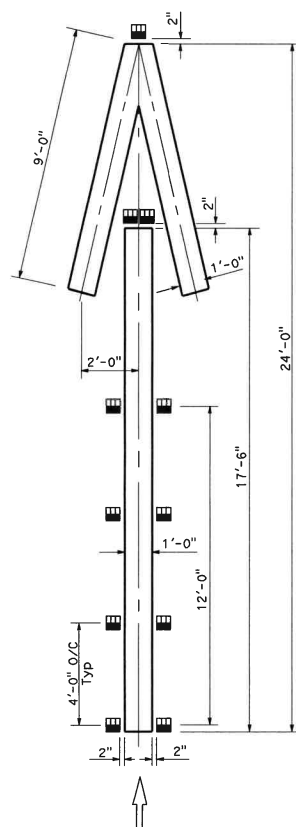

A=33 ft²

TYPE V ARROW AT EXIT RAMP

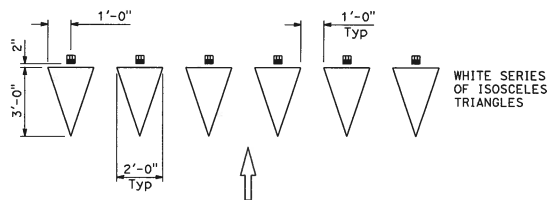

WHITE SERIES
OF ISOSCELES
TRIANGLES

YIELD LINE AT EXIT RAMP

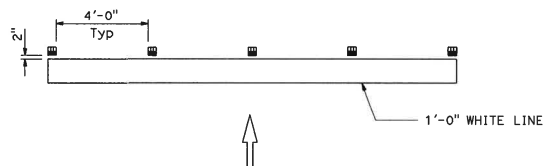

LIMIT LINE (STOP LINE) AT EXIT RAMP

NOTE:

1. If there is crosswalk at the end of the exit ramp, place Type R markers in front of the first line for wrong way vehicle that travels up the ramp with the red reflective side facing the intersection.

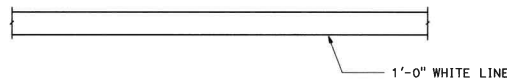

LIMIT LINE (STOP LINE)

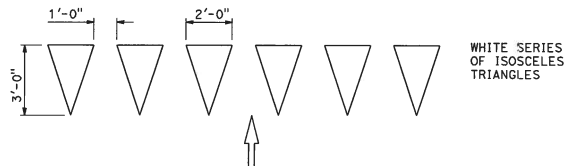

WHITE SERIES
OF ISOSCELES
TRIANGLES

YIELD LINE

LEGEND

MARKERS

- TYPE R ONE-WAY RED RETROREFLECTIVE

MARKER DETAILS

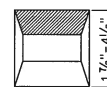
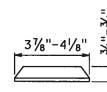

TYPE R

- RETROREFLECTIVE FACE ON BACKSIDE

2018 REVISED STANDARD PLAN RSP A24G

STATE OF CALIFORNIA
DEPARTMENT OF TRANSPORTATION
**PAVEMENT MARKINGS
YIELD LINES, LIMIT LINES,
AND WRONG WAY DETAILS**

NO SCALE

RSP A24G DATED OCTOBER 19, 2018 SUPPLEMENT TO THE STANDARD PLANS BOOK DATED 2018.

REVISED STANDARD PLAN RSP A24G

| DIST | COUNTY | ROUTE | POST MILES TOTAL PROJECT | SHEET NO. | TOTAL SHEETS |
|------|--------|-------|--------------------------|-----------|--------------|
| | | | | | |

H.R.F.
 REGISTERED ELECTRICAL ENGINEER
 Hamid Zolfaghar
 No. E15636
 Exp. 12-31-19
 REGISTERED PROFESSIONAL ENGINEER
 ELECTRICAL
 STATE OF CALIFORNIA

May 31, 2018
 PLANS APPROVAL DATE
 THE STATE OF CALIFORNIA OR ITS OFFICERS OR AGENTS SHALL NOT BE RESPONSIBLE FOR THE ACCURACY OR COMPLETENESS OF SCANNED COPIES OF THIS PLAN SHEET.

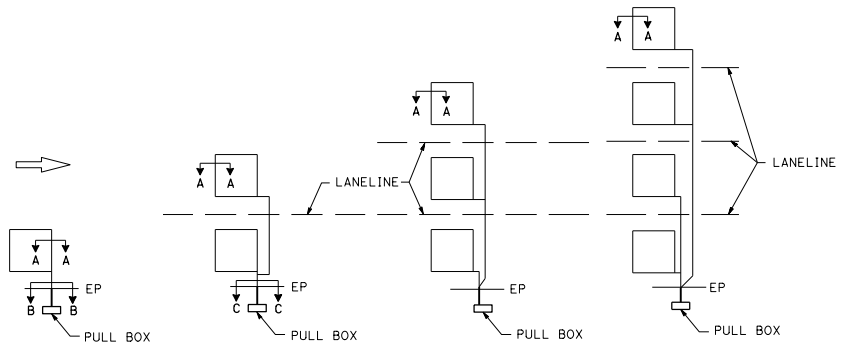

SAW CUT DETAILS

Type A loop detector configurations illustrated

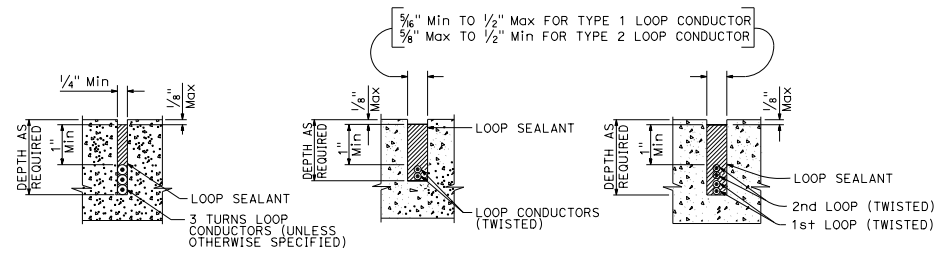

SLOT DETAILS - TYPE 1 AND TYPE 2 LOOP CONDUCTOR

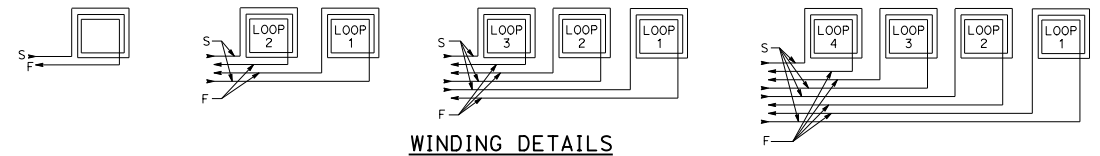

WINDING DETAILS

ABBREVIATIONS:

- S - START
- F - FINISH

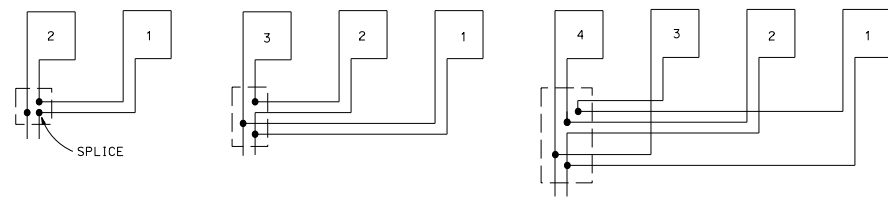

TYPICAL LOOP CONNECTIONS

Dashed lines represent the pull box

STATE OF CALIFORNIA
 DEPARTMENT OF TRANSPORTATION
**ELECTRICAL SYSTEMS
 (LOOP DETECTORS)**

NO SCALE

ES-5A

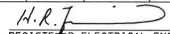
| DIST | COUNTY | ROUTE | POST MILES | SHEET TOTAL |
|---|--------|-------|---------------|-------------|
| | | | TOTAL PROJECT | No. SHEETS |
| | | | | |
|  REGISTERED ELECTRICAL ENGINEER Hanid Zolfaghar No. E15636 Exp. 12-31-19 ELECTRICAL ENGINEER STATE OF CALIFORNIA | | | | |
| October 19, 2018 PLANS APPROVAL DATE THE STATE OF CALIFORNIA OR ITS OFFICERS OR AGENTS SHALL NOT BE RESPONSIBLE FOR THE ACCURACY OR COMPLETENESS OF SCANNED COPIES OF THIS PLAN SHEET. | | | | |

TO ACCOMPANY PLANS DATED _____

- NOTES:**
1. Round corners of acute angle saw cuts to prevent damage to conductors.
 2. Typical distance separating loops from edge to edge is 10' for Type A, B, D, E, and F installation in single lane.
 3. Use Type D and F loops for limit line detection and bicycle lanes.

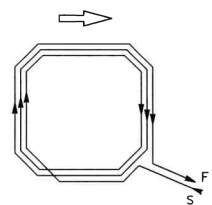

WINDING DETAIL
TYPE A LOOP DETECTOR CONFIGURATION

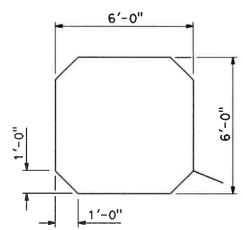

SAW CUT DETAIL

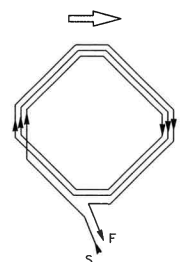

WINDING DETAIL
TYPE B LOOP DETECTOR CONFIGURATION

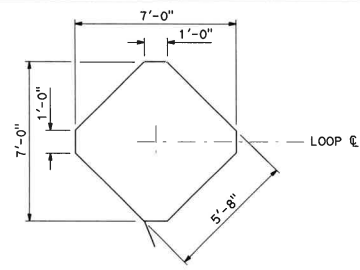

SAW CUT DETAIL

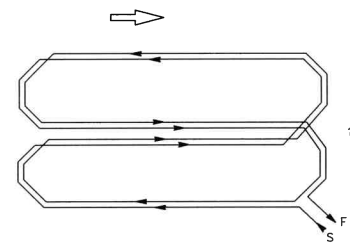

WINDING DETAIL
TYPE C LOOP DETECTOR CONFIGURATION

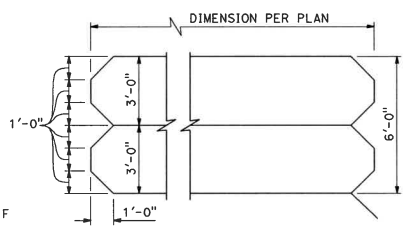

SAW CUT DETAIL

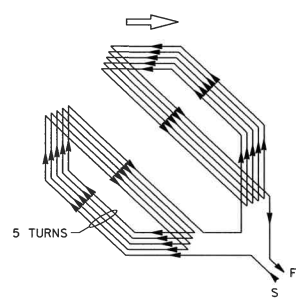

WINDING DETAIL
TYPE D LOOP DETECTOR CONFIGURATION

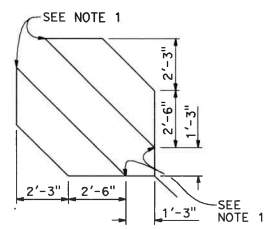

SAW CUT DETAIL

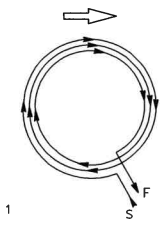

WINDING DETAIL
TYPE E LOOP DETECTOR CONFIGURATION

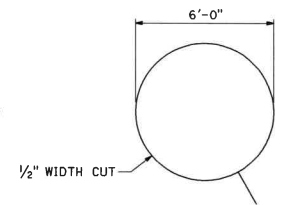

SAW CUT DETAIL

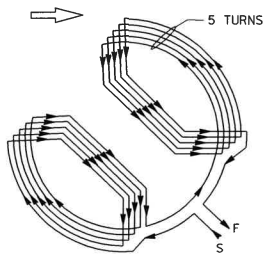

WINDING DETAIL
TYPE F LOOP DETECTOR CONFIGURATION

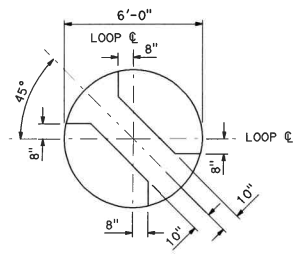

SAW CUT DETAIL

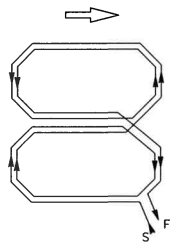

WINDING DETAIL
TYPE Q LOOP DETECTOR CONFIGURATION

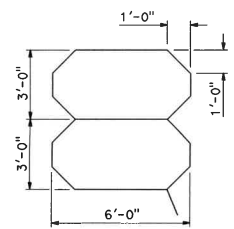

SAW CUT DETAIL

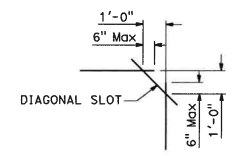

PLAN VIEW OF
DIAGONAL SLOT
AT CORNERS

STATE OF CALIFORNIA
DEPARTMENT OF TRANSPORTATION
ELECTRICAL SYSTEMS
(DETECTORS)

NO SCALE

RSP ES-5B DATED OCTOBER 19, 2018 SUPERSEDES STANDARD PLAN ES-5B
DATED MAY 31, 2018- PAGE 505 OF THE STANDARD PLANS BOOK DATED 2018.

REVISED STANDARD PLAN RSP ES-5B

2018 REVISED STANDARD PLAN RSP ES-5B

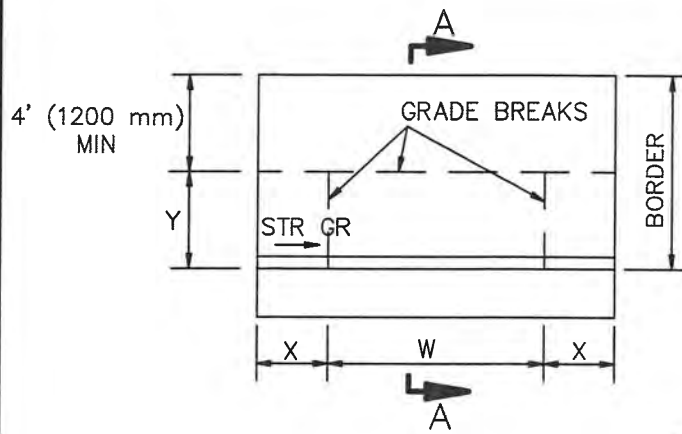

TYPE A

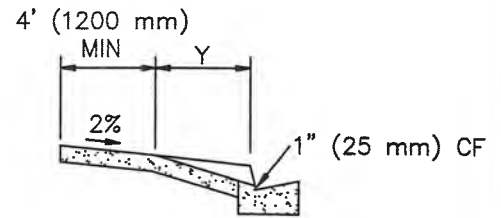

SECTION A-A

| CURB FACE, inches (mm) | X, inches (mm) | Y, inches (mm) |
|------------------------|----------------|----------------|
| 6" (150) or less | 3'-0" (900) | 4'-0" (1200) |
| 7" (175) | 3'-6" (1050) | 4'-9" (1425) |
| 8" (200) | 4'-0" (1200) | 5'-8" (1700) |
| 9" (225) | 4'-6" (1350) | 6'-6" (1950) |
| 10" (250) | 5'-0" (1500) | 7'-3" (2175) |
| 11" (275) | 5'-6" (1650) | 8'-0" (2400) |
| 12" (300) or more | 6'-0" (1800) | 8'-9" (2625) |

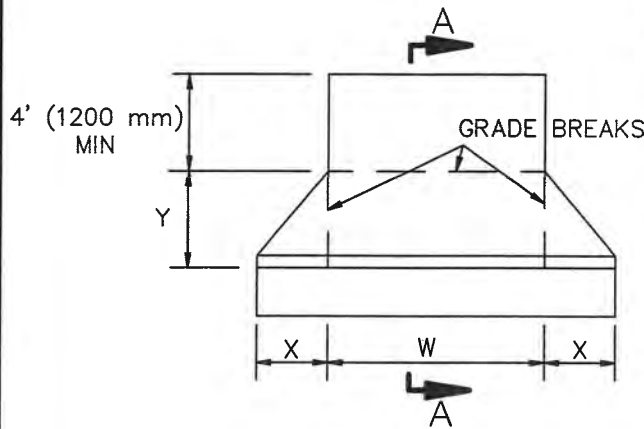

TYPE B

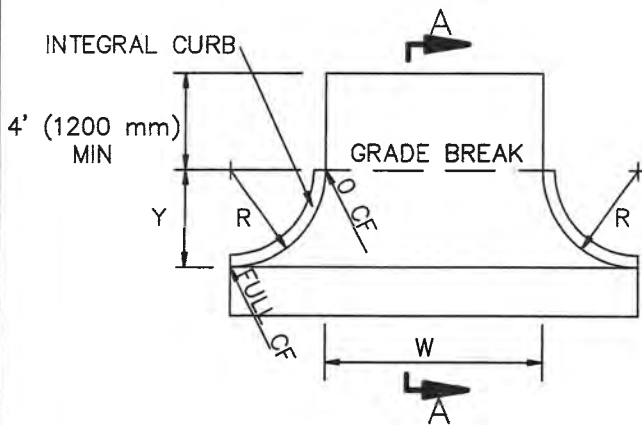

TYPE C

NOTES:

1. RESIDENTIAL DRIVEWAYS SHALL BE 4" (100 mm) THICK PCC.
2. COMMERCIAL DRIVEWAYS SHALL BE 6" (150 mm) THICK PCC.
3. WEAKENED PLANE JOINTS SHALL BE INSTALLED AT BOTH SIDES OF A DRIVEWAY AND AT 10' (3.0 m) INTERVALS.
4. CURB FOR TYPE C DRIVEWAY SHALL BE INTEGRAL AND MATCH ADJACENT CONSTRUCTION.
5. REFER TO LOCAL DEVELOPMENT REGULATIONS FOR AMERICANS WITH DISABILITIES ACCESS REQUIREMENTS AND MAXIMUM PERMITTED DRIVEWAY WIDTHS.

STANDARD PLANS FOR PUBLIC WORKS CONSTRUCTION

PROMULGATED BY THE
PUBLIC WORKS STANDARDS INC.
GREENBOOK COMMITTEE
1984
REV. 1996, 2009

DRIVEWAY APPROACHES

USE WITH STANDARD SPECIFICATIONS FOR PUBLIC WORKS CONSTRUCTION

STANDARD PLAN

110-2

SHEET 1 OF 1

WALK OR FILL-IN REPLACEMENT FOR EXCAVATIONS MADE PARALLEL TO CURB OR PROPERTY LINE

WALK ADJACENT TO PROPERTY LINE

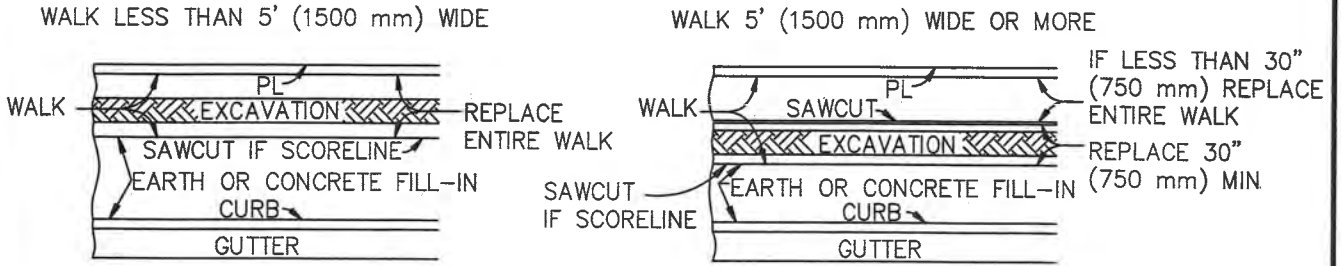

WALK ADJACENT TO CURB

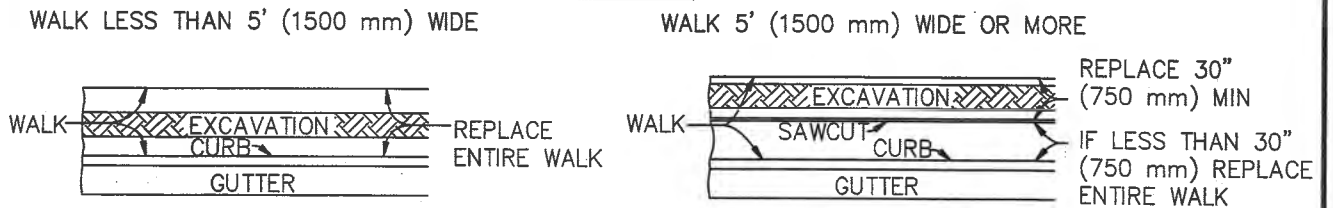

FILL-IN REPLACEMENT

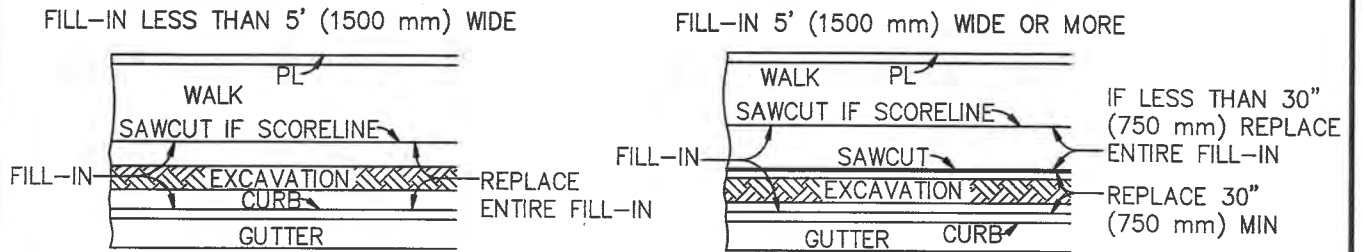

WALK OR FILL-IN REPLACEMENT FOR EXCAVATIONS MADE NORMAL TO CURB OR PROPERTY LINE

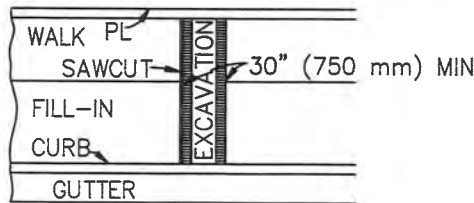

THESE REQUIREMENTS ALSO APPLY TO ENDS OF PARALLEL EXCAVATIONS.

IF AN EXCAVATION FALLS WITHIN 30" (750 mm) OF AN EXPANSION JOINT, CONSTRUCTION JOINT, WEAKENED PLANE JOINT, OR EDGE, THE CONCRETE SHALL BE REMOVED AND REPLACED TO THE JOINT OR EDGE.

IF AN EXCAVATION FALLS WITHIN 12" (300 mm) OF A SCORELINE, THE CONCRETE SHALL BE REMOVED AND REPLACED TO THE SCORELINE. THE SCORELINE SHALL BE SAWCUT BEFORE CONCRETE REMOVAL.

THE MINIMUM LENGTH OF REPLACEMENT IN BOTH CASES SHALL BE 30" (750 mm).

STANDARD PLANS FOR PUBLIC WORKS CONSTRUCTION

PROMULGATED BY THE
PUBLIC WORKS STANDARDS INC.
GREENBOOK COMMITTEE
1993
REV. 1996, 2009

SIDEWALK & DRIVEWAY REPLACEMENT

USE WITH STANDARD SPECIFICATIONS FOR PUBLIC WORKS CONSTRUCTION

STANDARD PLAN

113-2

SHEET 1 OF 2

NOTES

1. CONCRETE WALK, FILL-IN AND DRIVEWAYS REMOVED IN CONNECTION WITH CONSTRUCTION SHALL BE REPLACED TO NEATLY SAWED EDGES. ALL CUTS SHALL BE PARALLEL TO OR PERPENDICULAR TO THE CURB; ON CURVES, THE CUT SHALL BE RADIAL TO THE CURB.
2. DRIVEWAY APRONS IN WHICH THE "W" DISTANCE IS LESS THAN 11' (3300 mm) SHALL BE REPLACED IN THEIR ENTIRETY IF CUT IN ANY AREA.
3. DRIVEWAY APRONS IN WHICH THE "W" DISTANCE IS 11' (3300 mm) OR MORE MAY BE CUT WITHIN THE "W" SECTION. THE MINIMUM REPLACEMENT SHALL BE 30" (750 mm) IN LENGTH. THE MINIMUM DISTANCE ALLOWED BETWEEN SUCH CUTS SHALL BE 14' (4200 mm).
4. DRIVEWAY APRONS IN WHICH THE "W" DISTANCE IS 11' (3300 mm) OR MORE MAY BE CUT IN THE "X" OR "R" SECTION. REPLACEMENT SHALL BE THE ENTIRE "X" OR "R" SECTION.
5. DRIVEWAY APRONS SHALL BE REPLACED FROM THE BACK OF THE CURB TO THE FRONT EDGE OF THE WALK, EXCEPT, WHERE WALK IS ADJACENT TO CURB, REPLACEMENT SHALL BE FROM BACK OF CURB TO BACK OF WALK.
6. WALK PORTIONS OF DRIVEWAYS SHALL BE REPLACED AS SHOWN ABOVE FOR EXCAVATIONS MADE PARALLEL OR NORMAL TO CURB.
7. REPLACEMENT OF THE "X" OR "R" SECTION SHALL MATCH EXISTING CONSTRUCTION.

STANDARD PLANS FOR PUBLIC WORKS CONSTRUCTION

SIDEWALK & DRIVEWAY REPLACEMENT

STANDARD PLAN

113-2

SHEET 2 OF 2

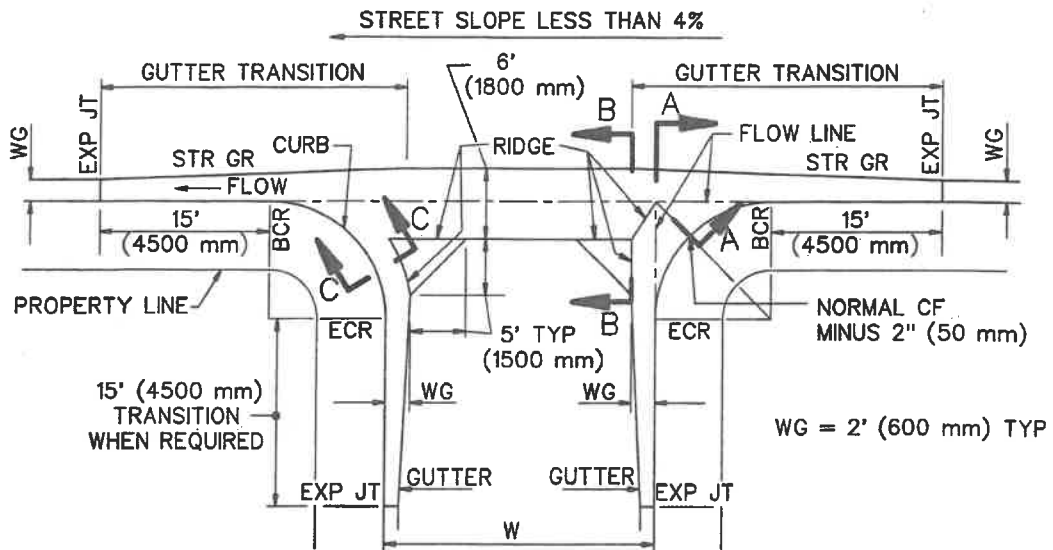

**TYPICAL CROSS GUTTER PLAN
STREET SLOPE LESS THAN 4%**

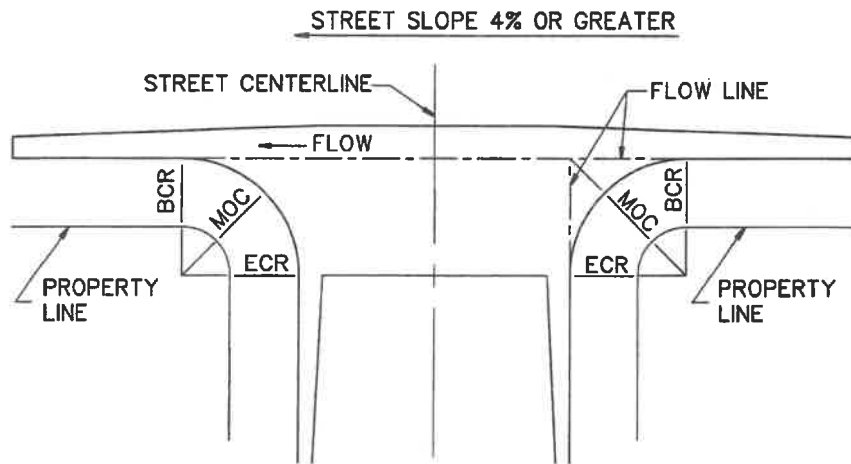

**TYPICAL CROSS GUTTER PLAN
STREET SLOPE 4% OR GREATER**

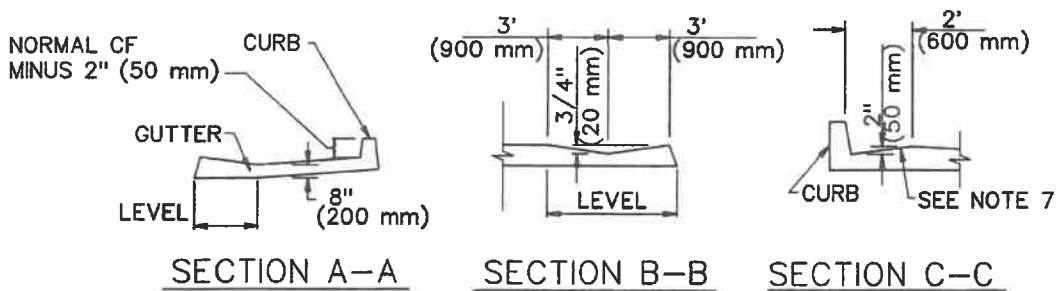

SECTION A-A

SECTION B-B

SECTION C-C

STANDARD PLANS FOR PUBLIC WORKS CONSTRUCTION

PROMULGATED BY THE
PUBLIC WORKS STANDARDS INC.
GREENBOOK COMMITTEE
1984
REV. 1993, 2009, 2021

CROSS AND LONGITUDINAL GUTTERS

STANDARD PLAN

122-3

USE WITH STANDARD SPECIFICATIONS FOR PUBLIC WORKS CONSTRUCTION

SHEET 1 OF 2

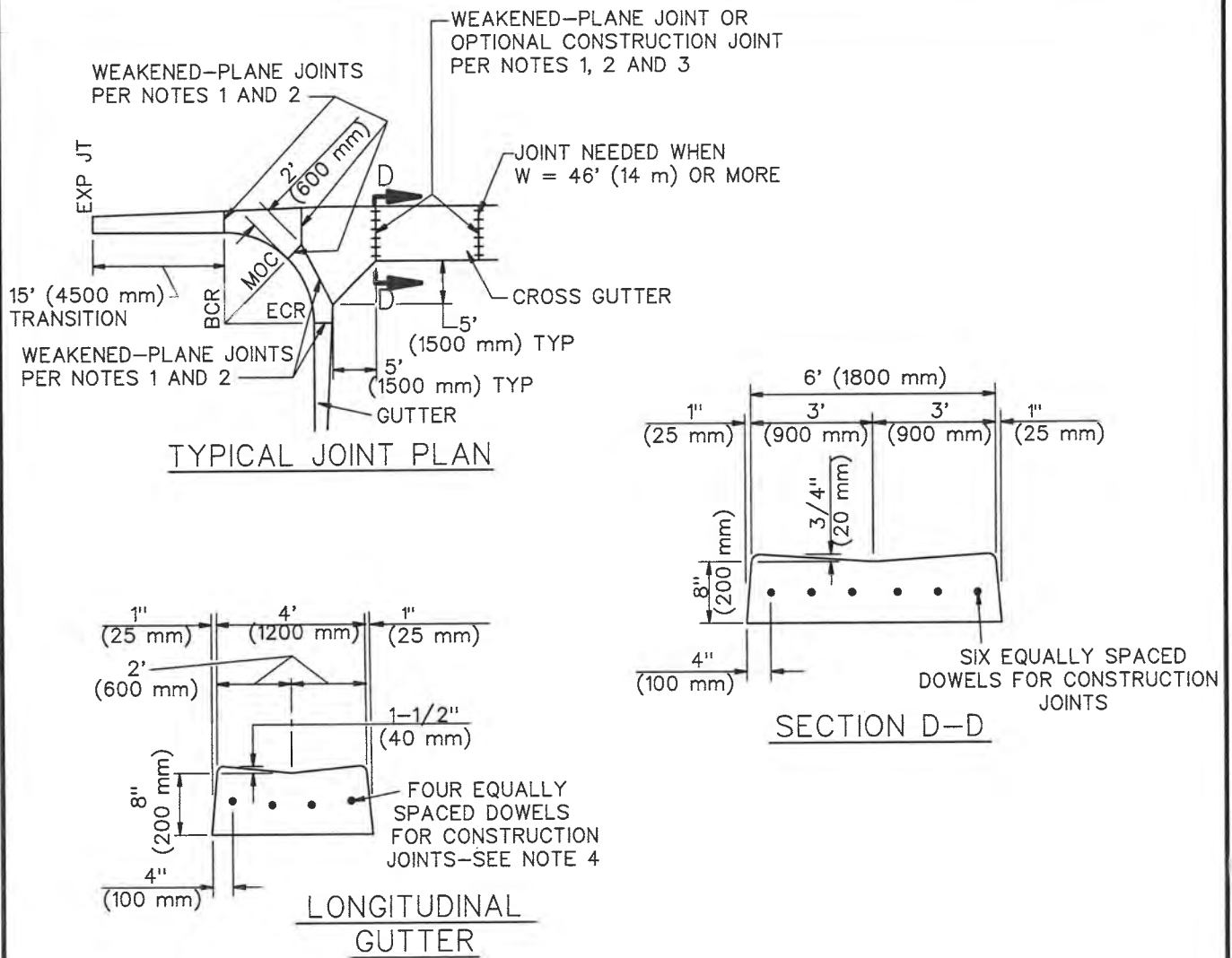

NOTES:

1. WEAKENED-PLANE AND/OR CONSTRUCTION JOINTS SHALL BE PLACED IN CURB AND GUTTER AT LOCATIONS SHOWN ON THE TYPICAL JOINT PLAN HEREON.
2. WEAKENED-PLANE JOINTS SHALL BE PLASTIC CONTROL JOINTS OR 1-1/2" (40 mm) DEEP SAW CUTS. CONCRETE SAWING SHALL TAKE PLACE WITHIN 24 HOURS AFTER CONCRETE IS PLACED.
3. DOWELS FOR CONSTRUCTION JOINTS SHALL BE #4 BARS 18" LONG (#13M BARS 450 mm LONG).
4. PLACE A WEAKENED-PLANE OR CONSTRUCTION JOINT WHERE LONGITUDINAL ALLEY GUTTER JOINS CONCRETE ALLEY INTERSECTION.
5. ALL EXPOSED CORNERS ON PCC CURBS AND GUTTERS SHALL BE ROUNDED WITH 1/2" (15 mm) RADIUS.
6. CONCRETE SHALL BE INTEGRAL WITH CURB UNLESS OTHERWISE SPECIFIED.
7. ADJACENT TO CURB RAMPS, CONCRETE SLOPE SHALL BE 5% MAXIMUM FOR A DISTANCE OF 5 FEET (1525 mm) FROM THE CURB FACE FOR THE WIDTH OF THE WIDTH OF THE RAMP, NOT INCLUDING SIDE TRANSITION CURBS.

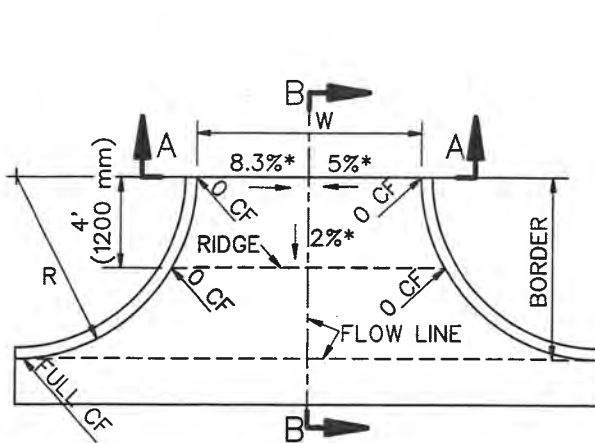

CASE A
STANDARD APPROACH

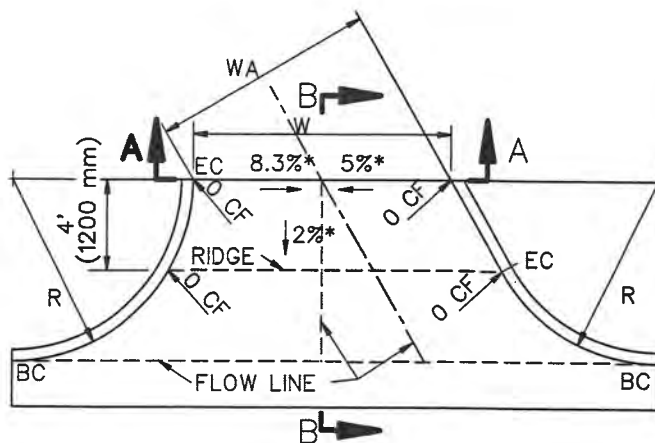

CASE B
ANGLED APPROACH

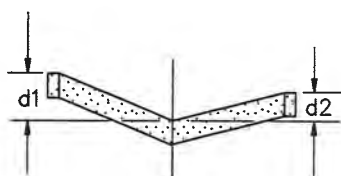

SECTION
A-A

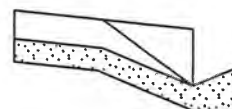

SECTION
B-B

| | | | | | | |
|--------|-----------|-----------|-----------|-----------|-----------|-----------|
| W, ft | 8' | 10' | 15' | 20' | 25' | 30' |
| W, mm | (2400 mm) | (3000 mm) | (4500 mm) | (6000 mm) | (7500 mm) | (9000 mm) |
| d1, ft | 0.33' | 0.42' | 0.63' | 0.83' | 1.04' | 1.25' |
| MAX | (100 mm) | (125 mm) | (188 mm) | (250 mm) | (313 mm) | (375 mm) |
| d2, ft | 0.17' | 0.25' | 0.25' | 0.25' | 0.25' | 0.25' |
| MIN | (50 mm) | (75 mm) | (75 mm) | (75 mm) | (75 mm) | (75 mm) |

NOTES:

1. ALLEY INTERSECTION SHALL BE CONSTRUCTED OF CONCRETE, CLASS 520-C-2500 (310-C-17), 6" (150 mm) THICK.
2. ASTERISKS (*) SHOW MAXIMUM GRADES.

STANDARD PLANS FOR PUBLIC WORKS CONSTRUCTION

PROMULGATED BY THE
PUBLIC WORKS STANDARDS INC.
GREENBOOK COMMITTEE
1984
REV. 1996, 2009, 2021

ALLEY INTERSECTION

USE WITH STANDARD SPECIFICATIONS FOR PUBLIC WORKS CONSTRUCTION

STANDARD PLAN

130-3

SHEET 1 OF 1

CASE A

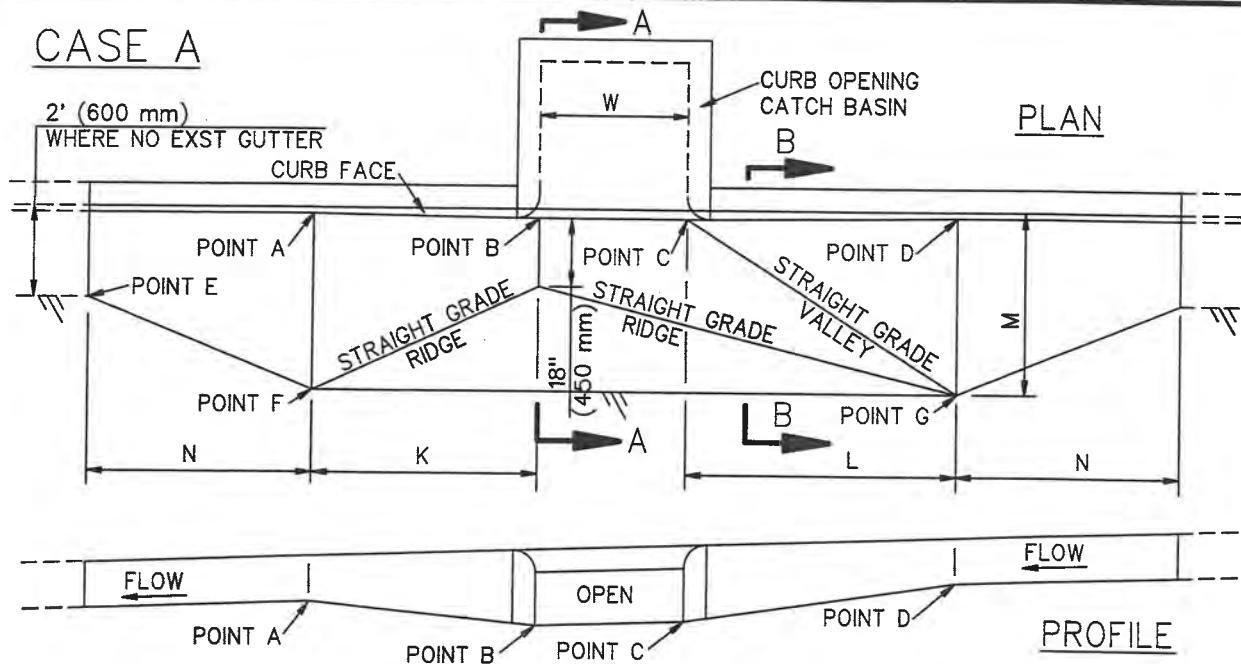

CASE B

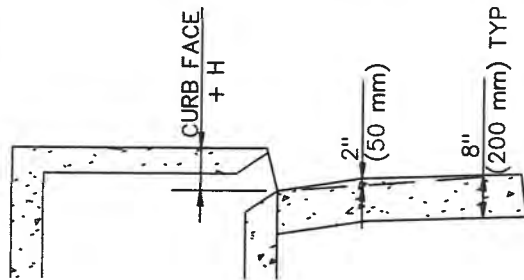
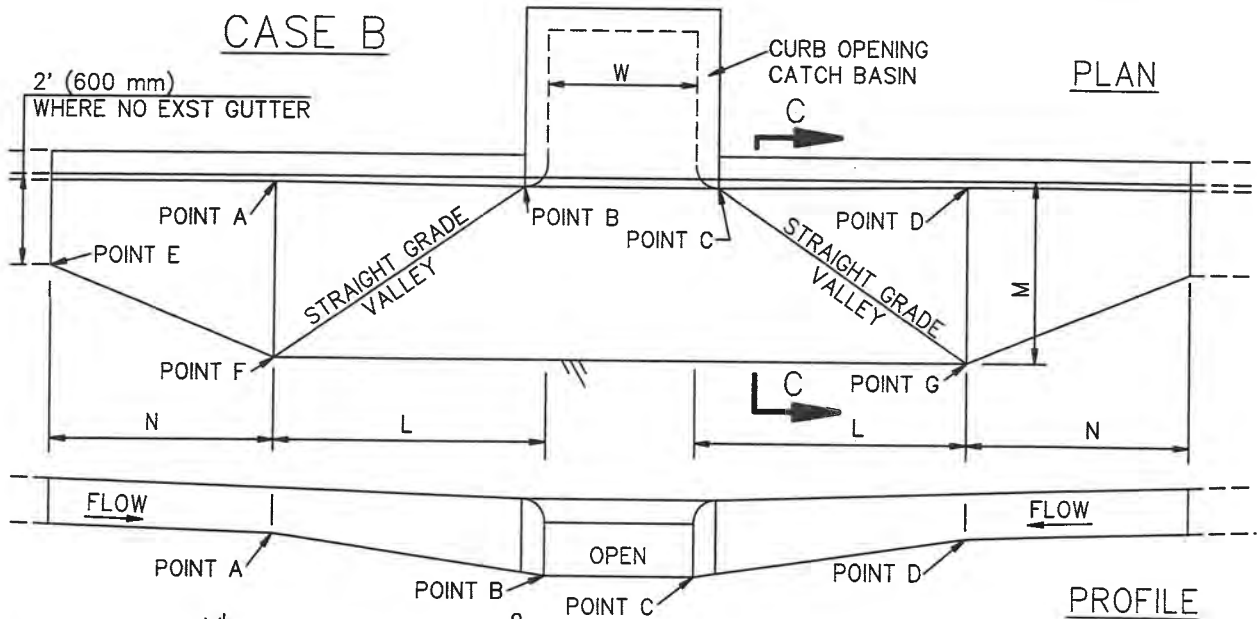

SECTION A-A

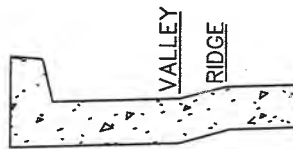

SECTION B-B

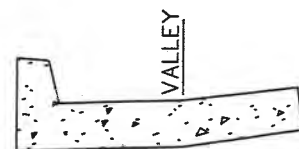

SECTION C-C

STANDARD PLANS FOR PUBLIC WORKS CONSTRUCTION

PROMULGATED BY THE
PUBLIC WORKS STANDARDS INC.
GREENBOOK COMMITTEE
1984
REV. 1996, 2005, 2009, 2021

LOCAL DEPRESSIONS AT CATCH BASINS

USE WITH STANDARD SPECIFICATIONS FOR PUBLIC WORKS CONSTRUCTION

STANDARD PLAN

313-4

SHEET 1 OF 4

NOTES:

1. ALL EXPOSED EDGES SHALL BE ROUNDED TO A 1/2" (15 mm) RADIUS.
2. THE CURB FACE AT POINTS A AND D SHALL BE THE NORMAL CURB FACE OF THE ADJACENT CURB AT THE ENDS OF THE LOCAL DEPRESSION. THE CURB FACE AT POINTS B AND C SHALL BE THE NORMAL CURB FACE OF THE ADJACENT CURB AT THE ENDS OF THE LOCAL DEPRESSION PLUS H (SEE APPLICABLE CATCH BASIN STANDARD PLAN.)
3. IN EXISTING STREETS WHERE NO PAVEMENT RECONSTRUCTION IS SPECIFIED ON THE PLANS, THE ELEVATION OF THE OUTER EDGE OF THE LOCAL DEPRESSION SHALL MEET THE FINISHED STREET SURFACE.
4. IN NEW STREETS OR IN EXISTING STREETS WHERE PAVEMENT RECONSTRUCTION IS SPECIFIED ON THE PLANS:

THE ELEVATIONS OF POINTS F AND G SHALL BE SET H1 HIGHER THAN THE GUTTER FLOW LINE ELEVATIONS AT POINTS A AND D, RESPECTIVELY.

THE ELEVATIONS OF POINTS P AND R SHALL BE SET H2 HIGHER THAN THE GUTTER FLOW LINE ELEVATIONS AT POINTS B AND C, RESPECTIVELY.

THE ELEVATION OF POINT S SHALL BE SET H2 HIGHER THAN THE ELEVATION AT THE NEAREST GUTTER FLOW LINE.

WHERE THERE IS NO GUTTER ADJACENT TO THE LOCAL DEPRESSION, THE ELEVATION OF POINT E SHALL BE SET H3 HIGHER THAN THE ELEVATION AT THE NEAREST TOE OF CURB.

5. DIMENSIONS:

H, H1, H2 AND H3 SHALL BE AS NOTED ON THE PLANS.

G = 24" (600 mm)

K = 5'-0" (1500 mm)

L = 6'-0" (1800 mm)

M = 4'-0" (1200 mm)

N = 5'-0" (1500 mm)

W = WIDTH OF CURB OPENING FOR CATCH BASIN

W_G = WIDTH OF GRATING(S) FOR CATCH BASIN

REV. 5-11-78 REV. 4/83 ; 9/84 ; 11/84

* Cross gutters at Arterial Highway Intersections shall be 8' in width

* REPLACES STD. DETAIL R-6
APPROVED 4-15-75

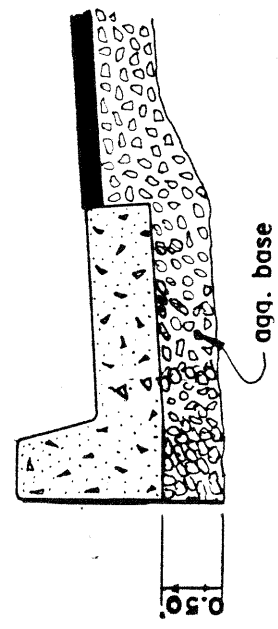
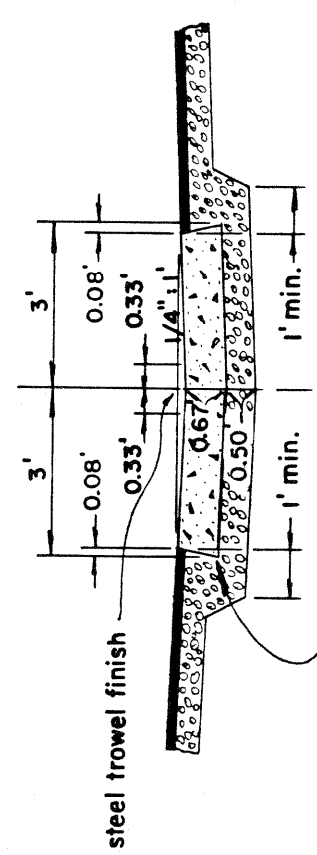
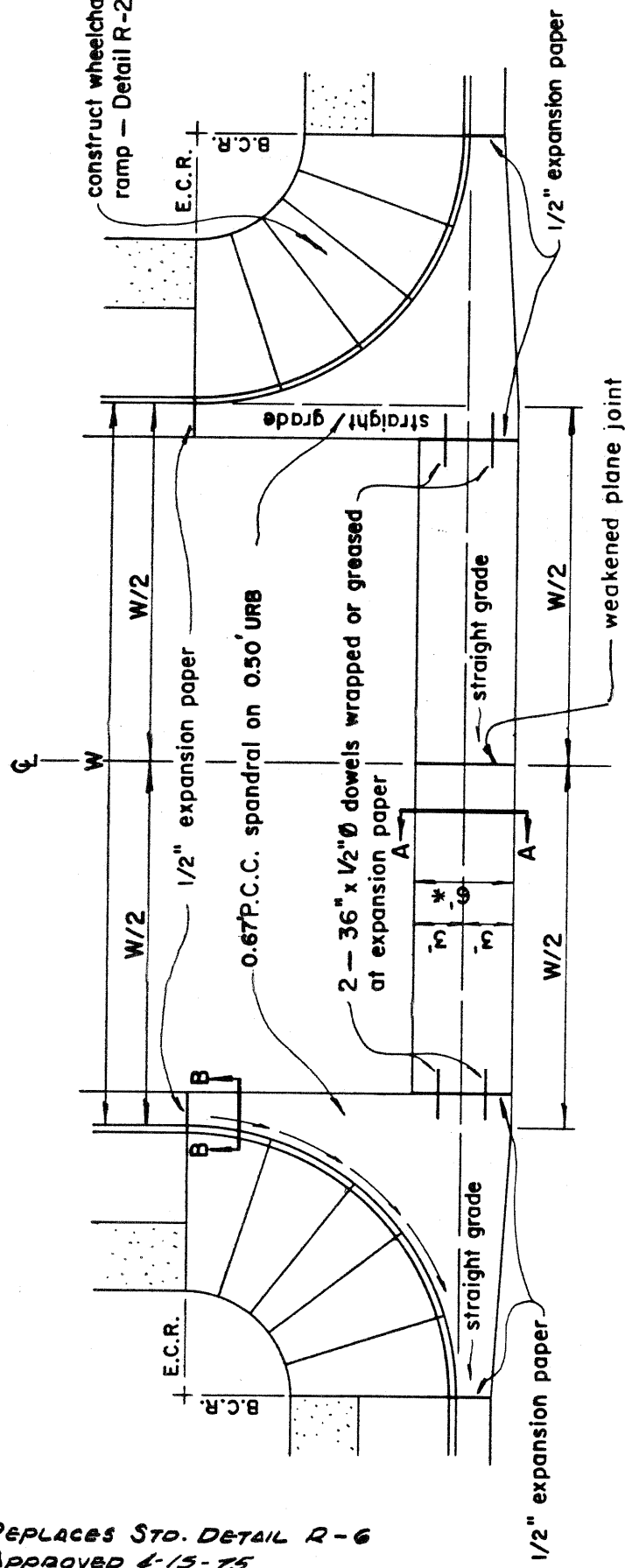

SECTION A-A

SECTION B-B

CITY OF LA HABRA

STANDARD CROSS GUTTER

APPROVED *R.L. [Signature]* DATE _____ STANDARD DETAIL R-6

NOTE:

Minimum Distance Between DRIVEWAYS in same lot shall be 22.00 Feet.
 CURB & GUTTER shall not be poured monolithic with the DRIVEWAY APRON.
 Property Line

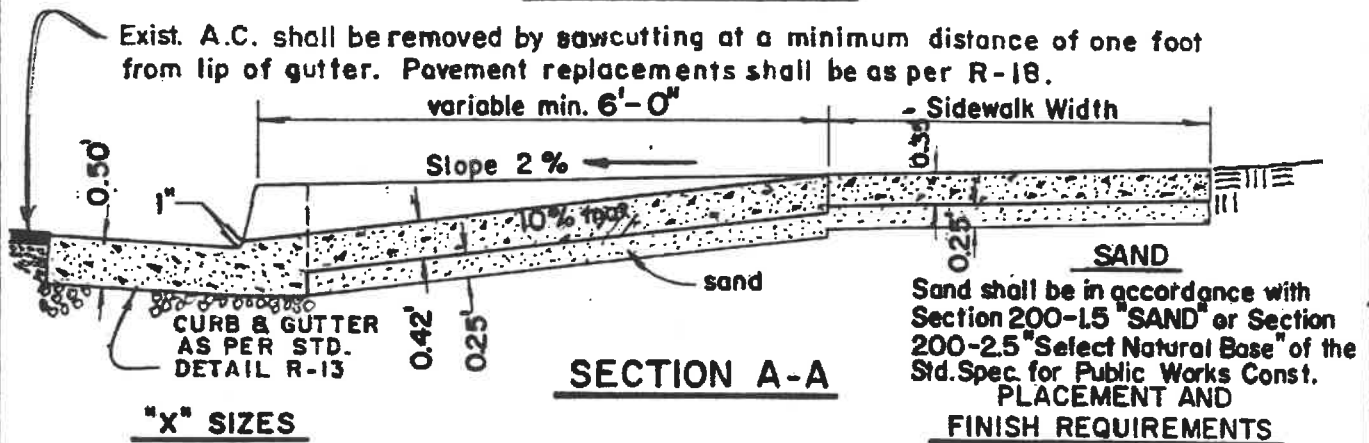
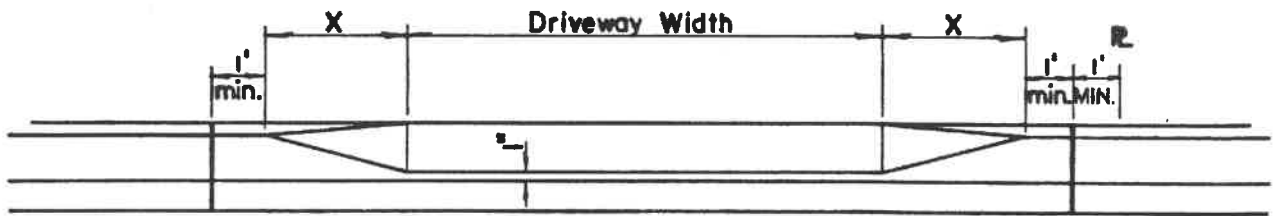
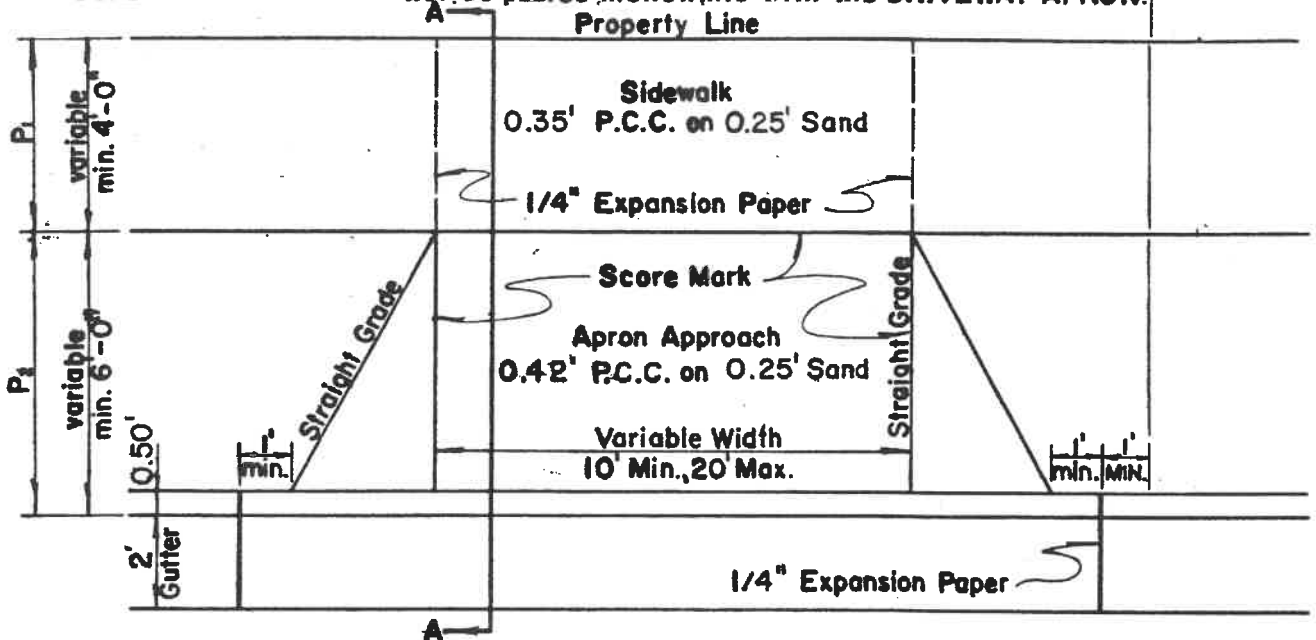

- "X" SIZES**
- 8" Curb Height
 - Residential Street X = 3'
 - Arterial Street X = 4'
 - 6" Curb Height
 - Residential Street X = 2.5'
 - Curb Height Greater Than 8" X = 4'

CONCRETE
 Class 520-C-2500. Per Section 201 of Standard Specification for Public Works Construction.

Fresh concrete shall be struck off and compacted until a layer of mortar has been brought to the surface. The surface shall then be finished to grade with a float and steel troweled smooth. Final finish shall be: coarse broom in P2 area, fine broom in P1 area.

REV. 7-22-85 REV. 2/24/86
 REV. 12-15-83

* Replaces Sto. Detail R-9 Approved 4-15-75

CITY OF LA HABRA

STANDARD RESIDENTIAL DRIVEWAY PARKWAY WIDTH \geq 10'

APPROVED: *[Signature]* DATE: _____

STANDARD DETAIL R-9

NOTE: Minimum Distance Between DRIVEWAYS in same lot shall be 22.00 Feet.
 CURB & GUTTER shall not be poured monolithic with the DRIVEWAY APRON.

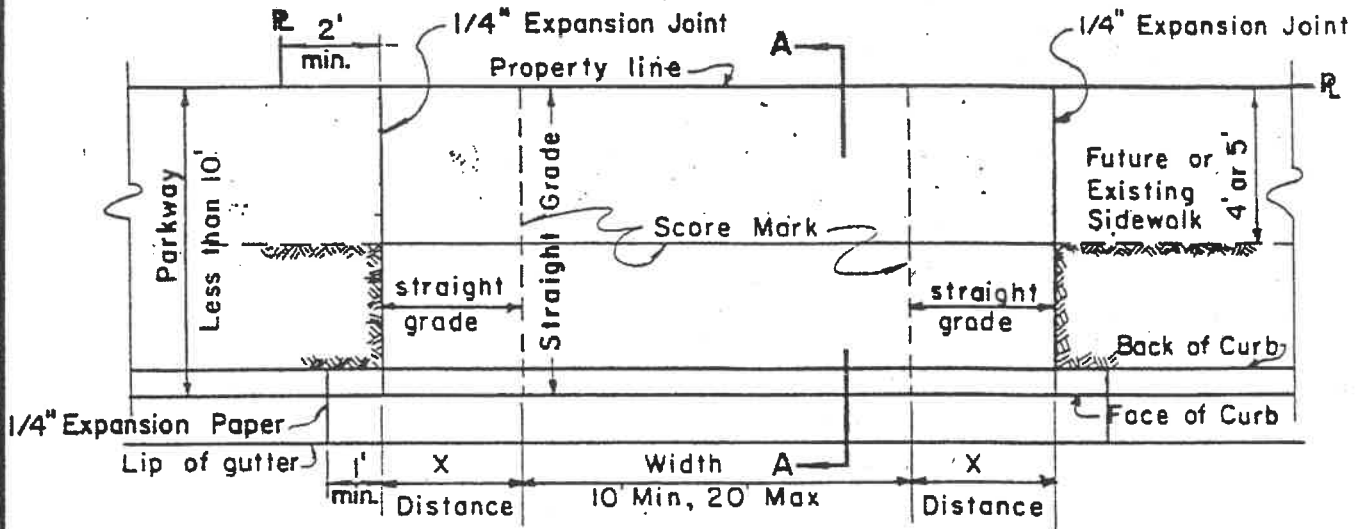

When Curb Face Is Less Than 8" - X Distance = 2.50'
 When Curb Face Is 8" Or More - X Distance = 3.00'

PLAN VIEW

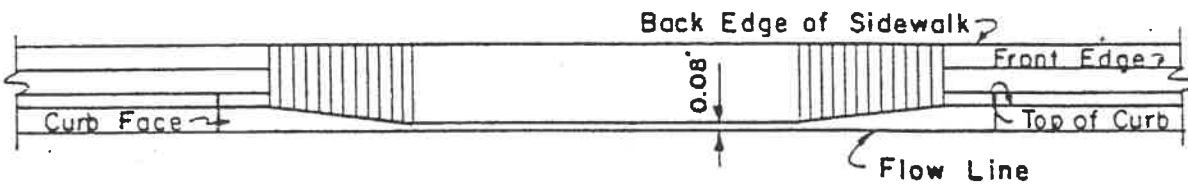

ELEVATION VIEW

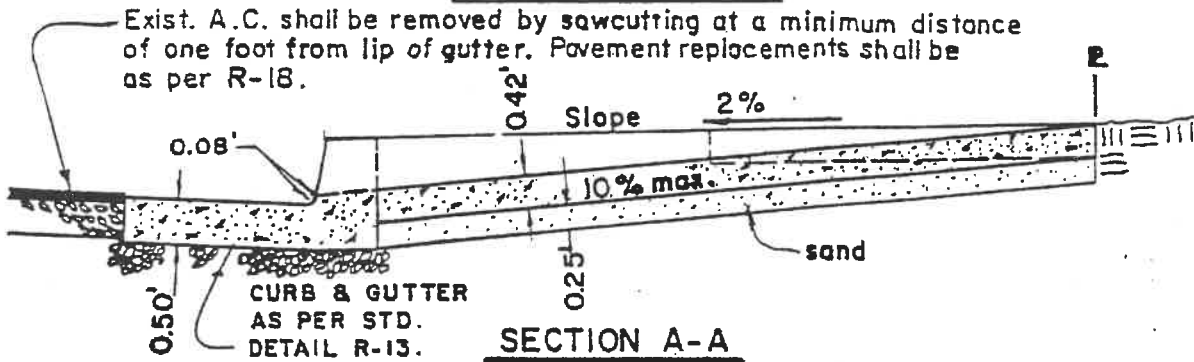

CONCRETE

Class 520-C-2500 Per Section 201 of Standard Specification for Public Works Construction.

SAND

Sand shall be in accordance with Section 200-1.5 "SAND" or Section 200-2.5 "Select Natural Base" of Standard Specification for Public Works Construction.

PLACEMENT AND FINISH REQUIREMENTS

Fresh concrete shall be struck off and compacted until a layer of mortar has been brought to the surface. The surface shall then be finished to grade with a float and steel troweled smooth and final finished with a coarse broom. Brooming shall be transverse to the line of traffic. Concrete adjacent to expansion paper shall be finished with an edger tool.

| REV | DATE | DESCRIPTION | BY |
|-----|---------|-------------------------------|-----|
| Δ | 6-20-77 | Rev. Spec. to conform to S.S. | W/S |
| | | | APD |

* REPLACES STD. DETAIL R-10
 APPROVED 4-15-75

REV. 12-15-83 REV. 2-24-86

CITY OF LA HABRA

STANDARD RESIDENTIAL DRIVEWAY PARKWAY WIDTH < 10'

APPROVED *[Signature]* DATE _____

STANDARD DETAIL R-10

NOTE: EXIST. A.C. SHALL BE REMOVED BY SAWCUTTING AT A MINIMUM DISTANCE OF ONE FOOT FROM LIP OF GUTTER. PAVEMENT REPLACEMENTS SHALL BE AS PER R-18.

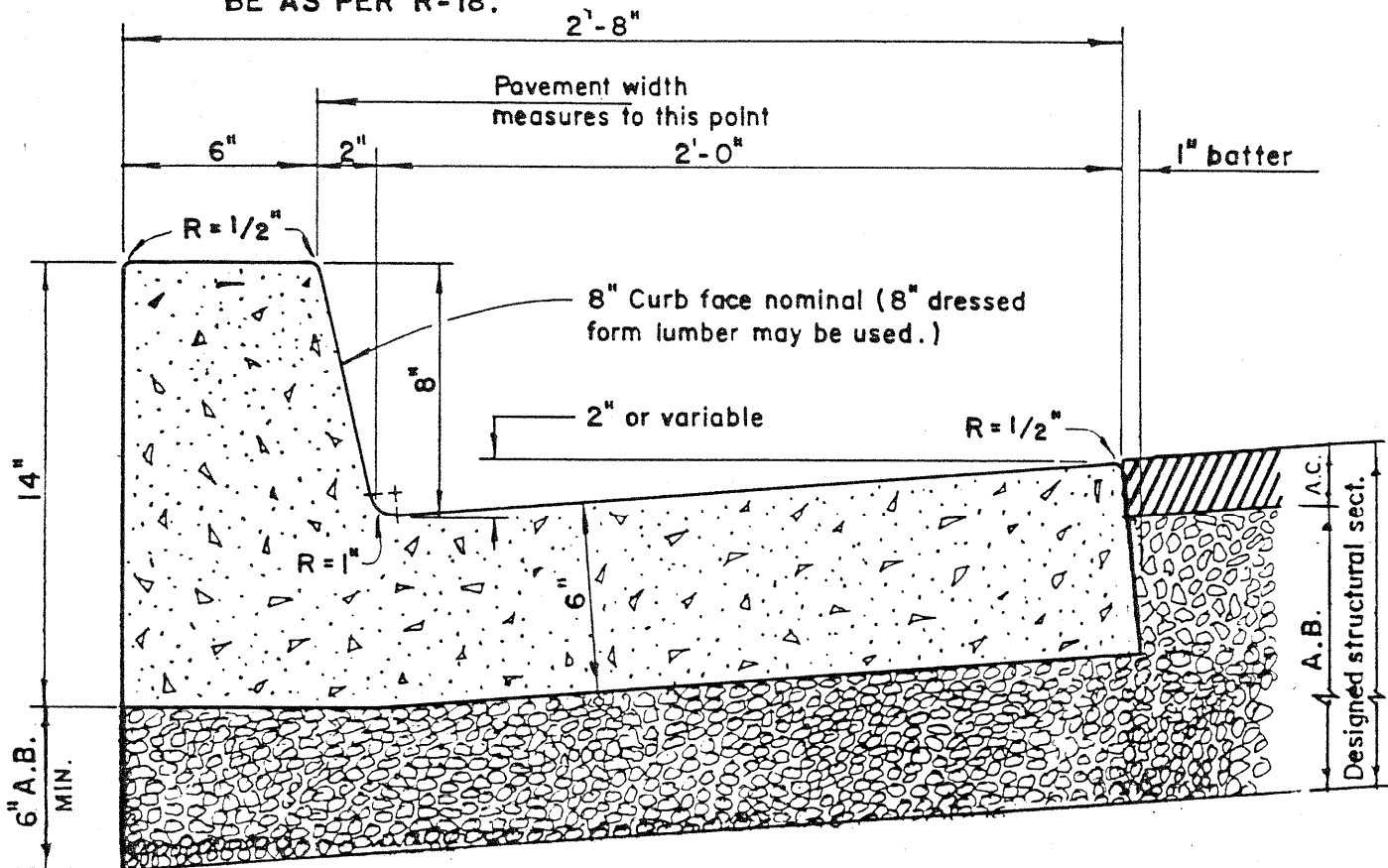

TYPE A 2-8

CONCRETE

Class 520-C-2500 per Section 201 Standard Specifications for Public Works Construction, Current Edition.

PLACEMENT AND FINISH REQUIREMENTS

Fresh concrete shall be struck off and compacted until a layer of mortar has been brought to the surface. The surface shall then be finished to grade with a float and steel troweled smooth. The top and face of the curb shall be final finished with a fine broom. The gutter shall be final finished with a coarse broom and with a 4" shiner along flowline. If a portion of the back of curb is to be exposed, it shall be final finished with a fine broom a minimum of 2" below the exposed surface.

All form lumber excepting curb face form lumber, shall remain in place a minimum of 24 hours.

AGGREGATE BASE

Aggregate Base shall be in accordance with Section 200-2.2 of Standard Specification for Public Works Construction.

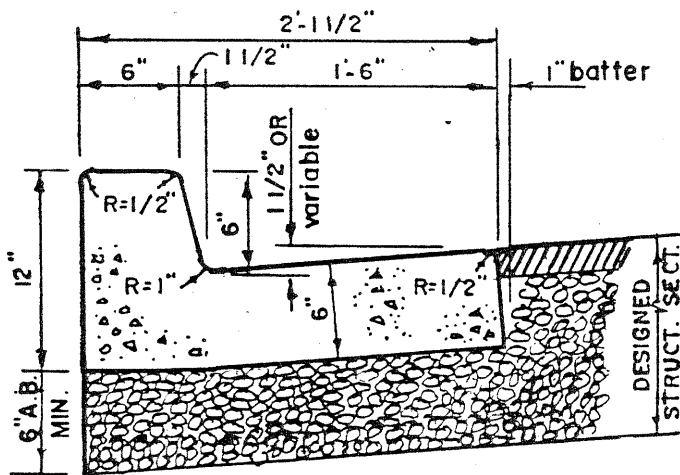

TYPE D

EXPANSION PAPER

1/4" Expansion paper shall be placed at intervals not to exceed 60' with a weakened plane joint every 20'.

CITY OF LA HABRA
STANDARD CURB & 2' GUTTER

APPROVED *R. L. ...* DATE: _____

STANDARD DETAIL R-13

REV. 5-11-78 REV. 4/83 REV. 4-30-84 ; 8-28-84 ; 2-25-86
* REPLACES STD. DETAIL R-13 APPROVED 4-15-75

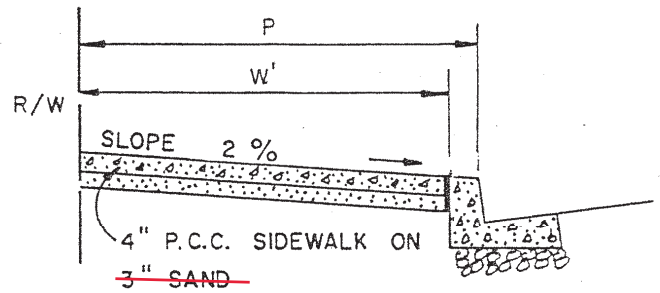
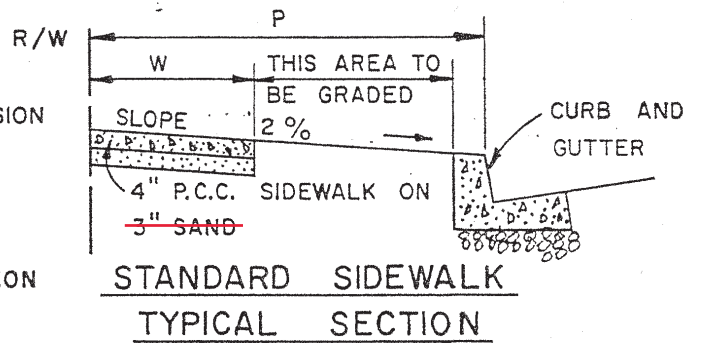
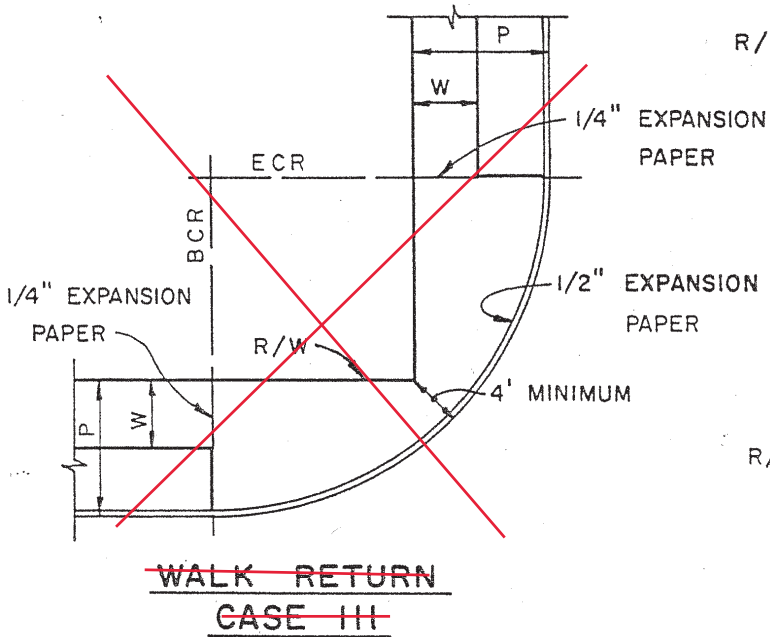
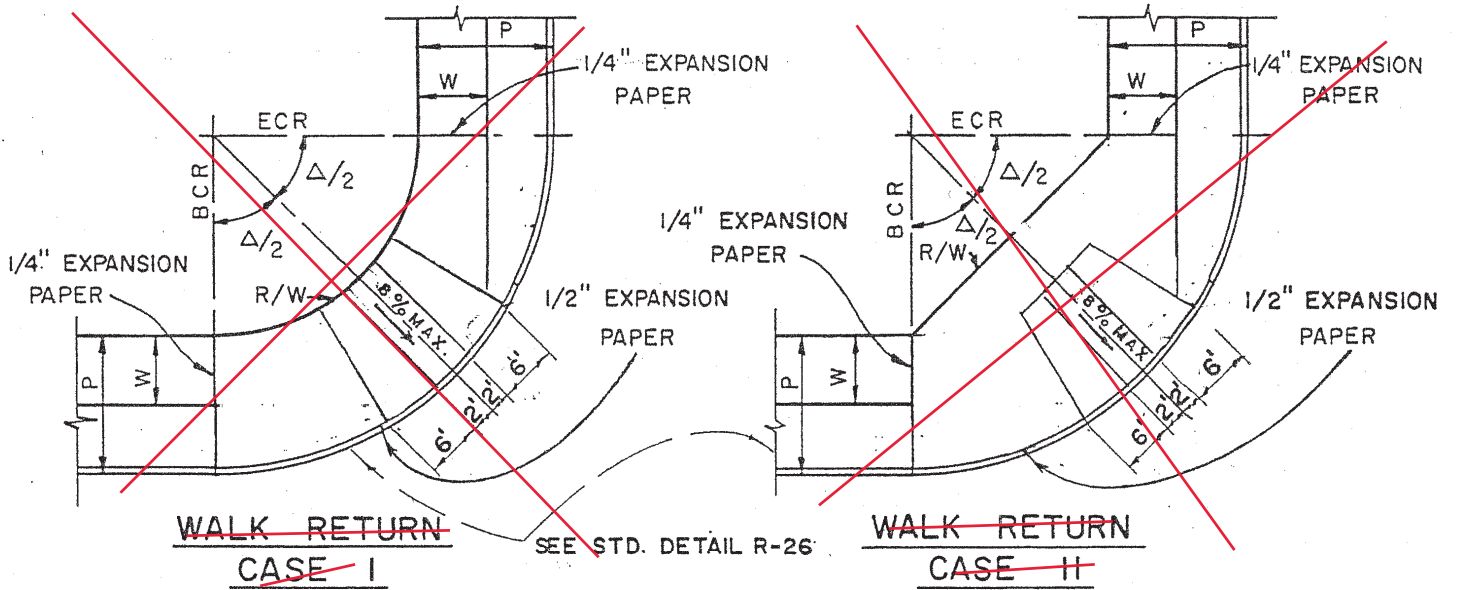

P = PARKWAY WIDTH AS NOTED ON PLAN
 W = 4' RESIDENTIAL & COLLECTOR STREETS
 W = 5' ARTERIAL HIGHWAYS
 W' = PARKWAY WIDTH

NOTES:

1. 1/4" EXPANSION PAPERS SHALL BE PLACED AT 60' INTERVALS.
2. CONCRETE — CLASS 520-C-2500 PER SECTION 201 OF STANDARD SPECIFICATIONS FOR PUBLIC WORKS CONSTRUCTION.
3. WEAKENED JOINTS SHALL BE PLACED AT 20' INTERVALS.
4. SAND SHALL HAVE A SAND EQUIVALENT OF NOT LESS THAN 30.

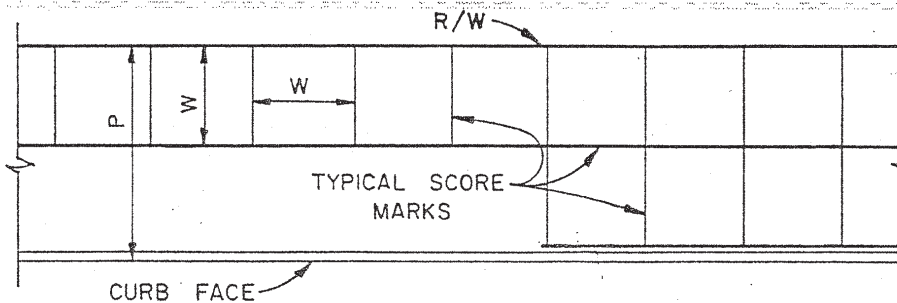

REV. 1-7-87 ; 7-C-87

5-30-78

CITY OF LA HABRA
STANDARD SIDEWALK RETURNS & MARKINGS

APPROVED *R.L. Buonadono* DATE 1-15-71

STANDARD DETAIL R-14

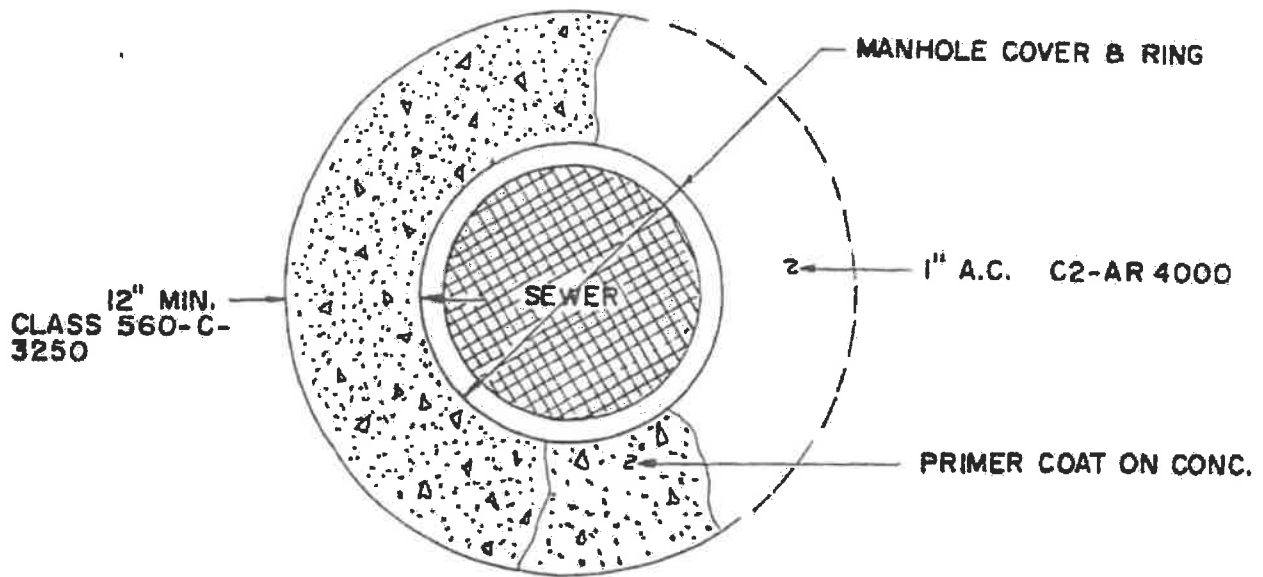

PLAN VIEW

CONC. MAY BE CIRCULAR OR SQUARE IN SHAPE WITH A MINIMUM DISTANCE OF 12" BETWEEN EDGE OF CONC. AND LIP OF M.H. RING.

MANHOLES MAY BE ADJUSTED TO GRADE USING BRICK AND MORTAR OR PRECAST RINGS AT THE CONTRACTORS OPTION.

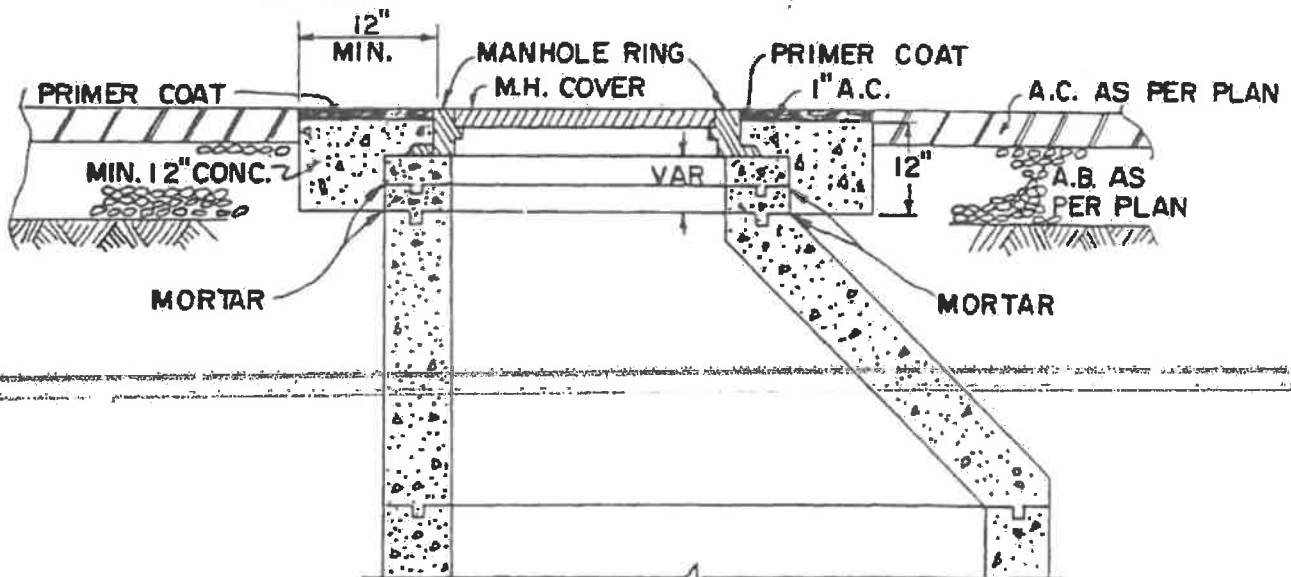

CROSS SECTION

CITY OF LA HABRA

MANHOLE ADJUSTMENT DETAILS

APPROVED *Rob B...* DATE 1-28-86

STANDARD DETAIL R-19A

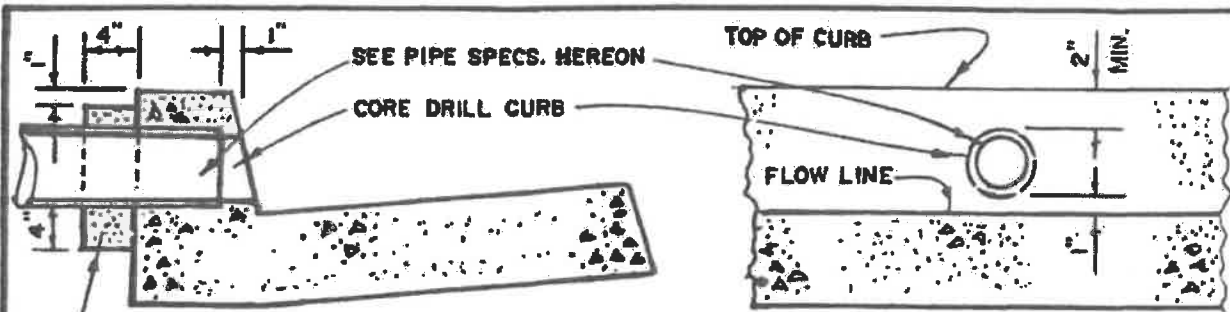

SINGLE CURB DRAIN THRU EXISTING CURB

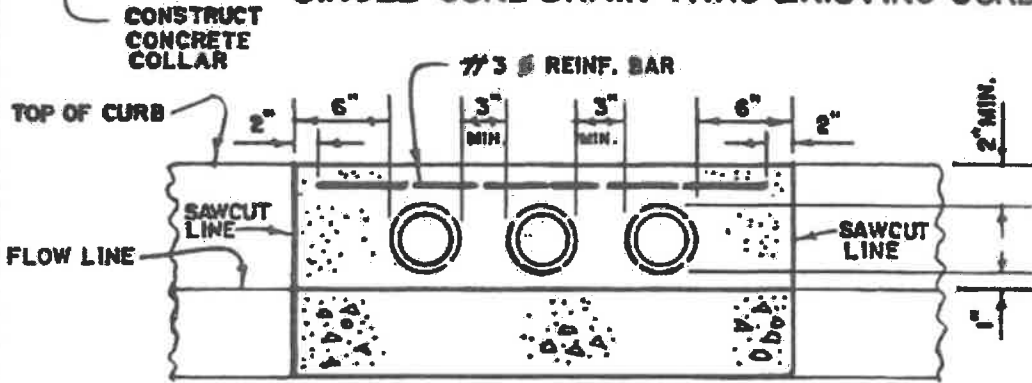

**MULTIPLE PIPE CURB DRAIN
REMOVE AND REPLACE CURB & GUTTER.**

PIPE SPECIFICATIONS:
 PIPE SHALL BE STEEL, CAST IRON
 OR P.V.C. (SCHEDULE 40).
 PIPE SIZE SHALL NOT EXCEED
 THE FOLLOWING:
 4" FOR 6" CURB FACE
 3" FOR 6" CURB FACE

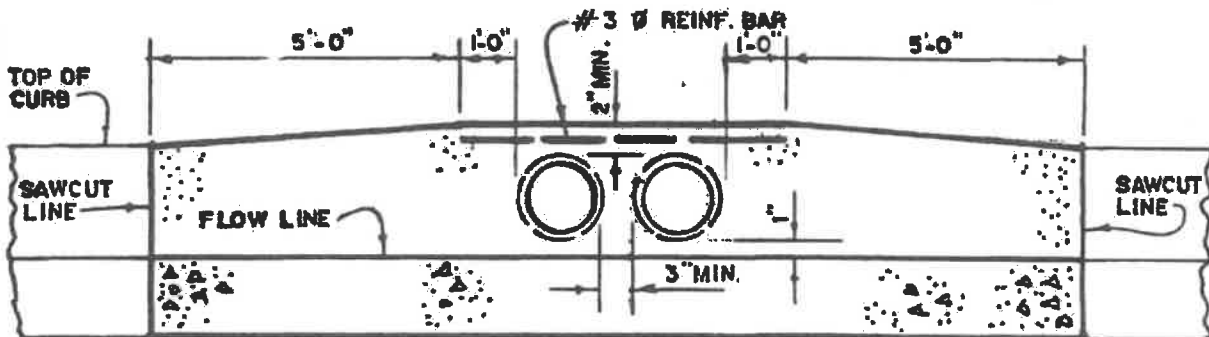

**CURB DRAIN LARGER THAN SPECIFIED MAXIMUM PIPE SIZE
CURB, GUTTER AND SIDEWALK SHALL BE REMOVED AND BE REPLACED.**

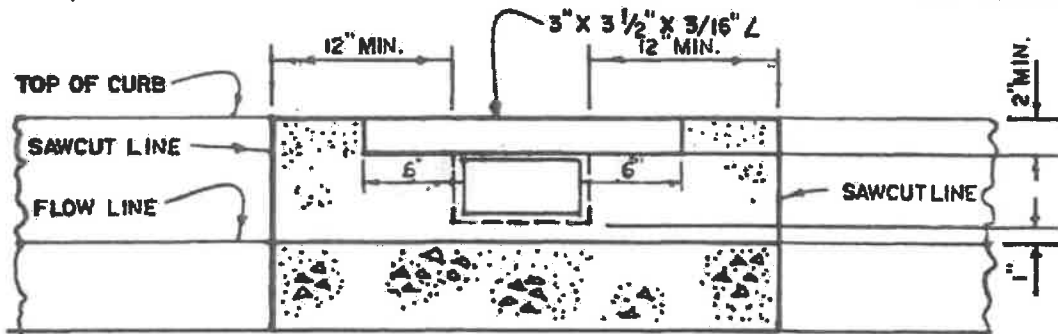

**PRECAST BOX CURB DRAIN
REMOVE AND REPLACE CURB & GUTTER.**

MAXIMUM WIDTH BOX SHALL BE 12" UNLESS APPROVED BY CITY ENGINEER

**CITY OF LA HABRA
STANDARD CURB DRAINS**

APPROVED *R.L. Dunsford* DATE 7-26-83 **STANDARD DETAIL R-20**

REV. 7-22-85

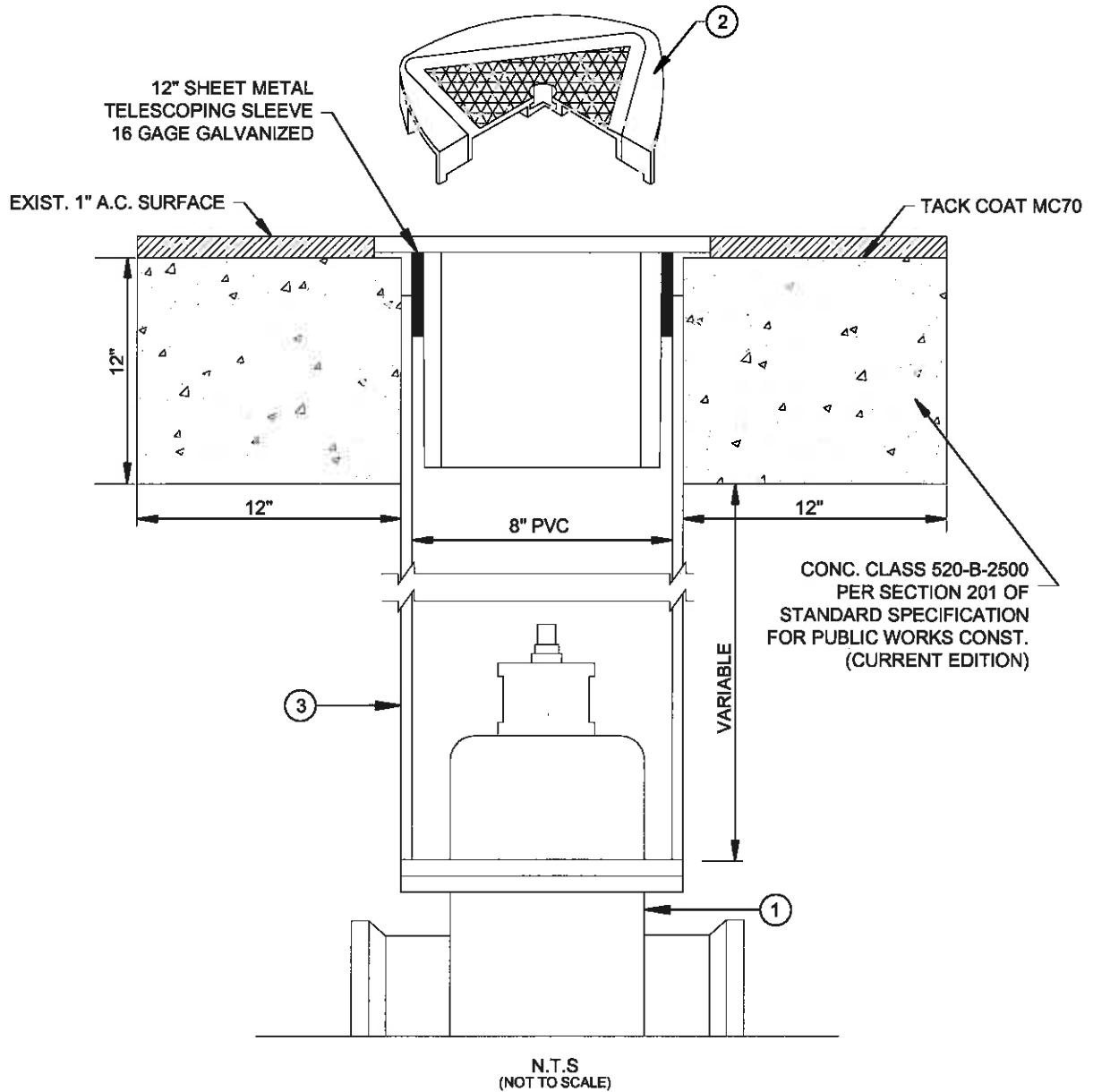

CONSTRUCTION ITEMS / MATERIALS LIST

| NO. | SIZE AND DESCRIPTION | MANUFACTURER |
|-----|--|-------------------------------------|
| ① | GATE VALVE, RESILIENT WEDGE, S.S. TRIM, MJ OR FLG-OPTION | M&H, KENNEDY OR APPROVED EQUAL |
| ② | VALVE BOX FRAME & COVER, C.I. | BROOKS 4TT FOR TRAFFIC USE OR EQUAL |
| ③ | PVC PIPE, 8", SCHEDULE 40 | |

| DATE | REV. | DESCRIPTION |
|------|------|-------------|
| | | |
| | | |

CITY OF LA HABRA

STANDARD VALVE BOX INSTALLATION



APPROVED: *Christopher J. Gonzalez* DATE: *7/23/12*

STANDARD DETAIL W-4

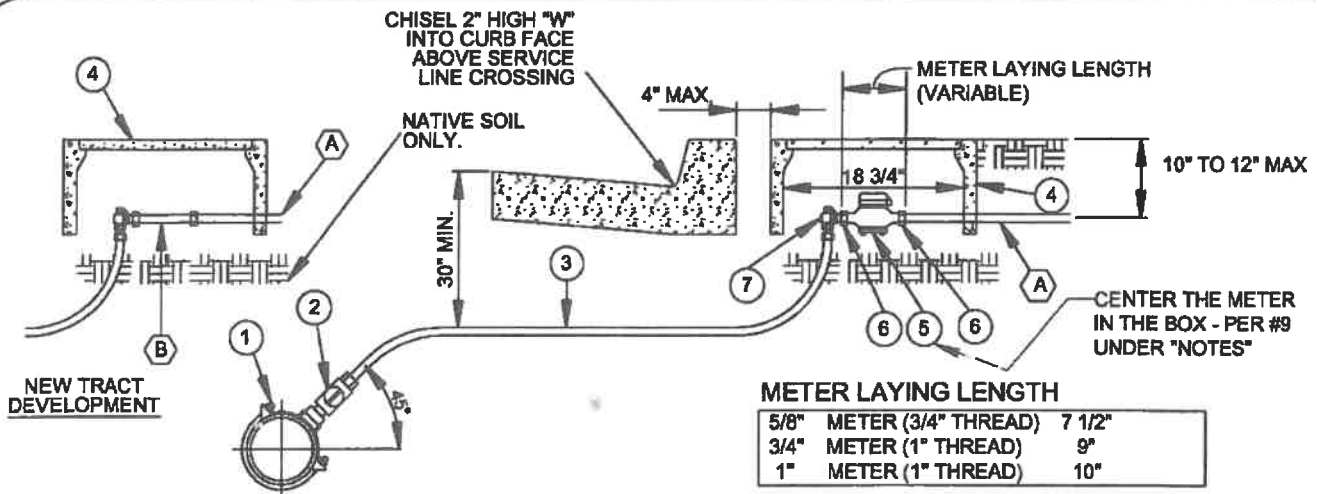

CONSTRUCTION ITEMS / MATERIALS LIST

| NO | SIZE AND DESCRIPTION | MANUFACTURER | MFR. CAT. NO. |
|----|---|--|---|
| ① | SERVICE SADDLE, BRONZE, IP TAP, DOUBLE STRAP | JONES, MUELLER, FORD | J-996, BR2B, 202B |
| ② | CORPORATION STOP; BRONZE, 1", MIP X PJ CTS | FORD, JONES | J3403, FB1100-4-G-NL, E1935SG, B-25028 |
| ③ | COPPER TUBING; 1", TYPE "K" SOFT | | |
| ④ | CONCRETE METER BOX WITH HINGED C.I. READING LID. 1" | H&C, BROOKS, EISEL | 437 3T(BOX) 437CIHL, 37 CIHL (COVER) |
| ⑤ | METER | FURNISHED & INSTALLED BY CONTRACTOR SEE NOTES 1 AND 5 (BELOW) | |
| ⑥ | METER COUPLING, BRONZE, 1" | FORD | C38-44 |
| ⑦ | ANGLE VALVE, BRONZE, 1", WITH LOCKING WING | FORD, JONES | KV43444WG, E1963WSGL/S |

NOTES:

- WHEN CONNECTING A 5/8" METER TO A 1" SERVICE, USE A BRONZE WATER METER BUSHING ON ONE OR BOTH ENDS (FORD A-34 OR APPROVED EQUAL).
- NO SPLICES WILL BE PERMITTED BETWEEN THE CORPORATION STOP AND THE ANGLE VALVE.
- NO TAP TO A MAIN SHALL BE WITHIN 18" OF A COUPLING OR WITHIN 18" OF ANOTHER TAP.
- UNDER NORMAL CONDITIONS THE WATER SERVICE SHALL EXTEND PERPENDICULAR TO THE CENTERLINE OF THE STREET FROM THE WATER MAIN TO THE ANGLE VALVE.
- METER IS TO BE INSTALLED BY THE CONTRACTOR AFTER METER BOX IS IN PLACE.
- ANGLE VALVE IS TO BE INSTALLED PLUMB AND SQUARE WITH THE CURB.
- IN NO CASE SHALL THE O.D. OF THE TUBE BE DISTORTED TO EXCEED 1.125 TIMES ORIGINAL DIAMETER.
- METER LAYING LENGTH IS MEASURED FROM THE FACE OF THE METER COUPLINGS. THE DISTANCE BETWEEN COUPLINGS SHALL NOT DEVIATE FROM THOSE SPECIFIED IN THE METER LAYING LENGTH TABLE.
- METER BOX IS TO BE POSITIONED SO THAT METER FACE IS HORIZONTALLY CENTERED WITHIN THE BOX.

(A) THE TOP OF THE BOX SHALL BE LEVEL AND FLUSH WITH THE TOP OF THE CURB. HOUSE LINE PLUMBING CODE REQUIREMENTS.

(B) JUMPER (AS NECESSARY) FOR TEMPORARY USE IN NEW TRACT DEVELOPMENT. THE LENGTH MUST CORRESPOND TO THE APPROPRIATE LENGTH OF THE METER TO BE INSTALLED BY CONTRACTOR AS SPECIFIED IN THE METER LAYING LENGTH TABLE ABOVE.

| DATE | REV. | DESCRIPTION |
|------|------|-------------|
| | | |
| | | |

NOTE: SEE STANDARD DETAIL W-21 FOR BEDDING, BACKFILL AND PAVING REQUIREMENTS.

CITY OF LA HABRA

1" DOMESTIC WATER SERVICE



APPROVED: *Christopher J. Johnson* DATE: 7/23/12

STANDARD DETAIL W-6

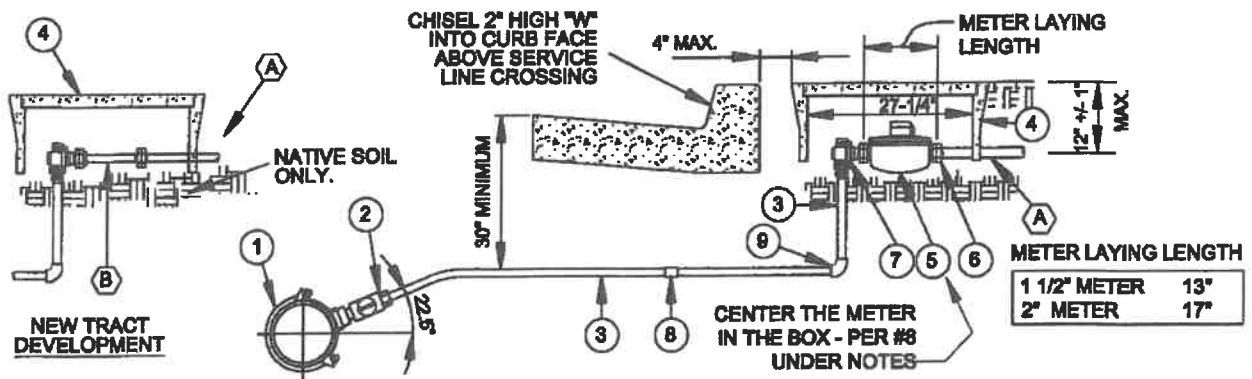

CONSTRUCTION ITEMS / MATERIALS LIST

| NO. | SIZE AND DESCRIPTION | MANUFACTURER | MFR. CAT. NO. |
|-----|---|--|---|
| 1 | SERVICE SADDLE, BRONZE, DOUBLE STRAP, 2", IP | JONES, MUELLER, FORD | J879, BR2B, 202B |
| 2 | CORPORATION STOP; BRONZE, 2", MIP X PJ CTS | FORD, JONES, MUELLER | FB1100-7-G-NL, E1935SG, B-25028 |
| 3 | COPPER TUBING; 2", TYPE "K" SOFT | | |
| 4 | CONCRETE METER BOX W/HINGED CI READ LID, #855 1/2 | EISEL, H&C, BROOKS | #855 1/2 (BOX) W655HL (COVER) |
| 5 | METER | FURNISHED & INSTALLED BY CONTRACTOR SEE NOTE 4 (BELOW) | |
| 6 | FLANGE BRONZE COUPLING WITH I.P. FEMALE THREAD. | FORD, MUELLER | CF31-86 (1"), CF31-77 (2"), E1935SG, EFA-43-777WR-G-NG, B-24276-3 |
| 7 | ANGLE VALVE, BRONZE 2" W/LOCKING WING, DOUBLE DRILLED | FORD, JONES | BFA43-778FLWLS FV43-777W |
| 8 | COPPER COUPLINGS; (SOLDERED CONNECTIONS) | | |
| 9 | COPPER 90° ELBOW; (SOLDERED CONNECTIONS) | | |
| 10 | BOLTS, 5/8" X 3", HOT DIPPED GALVANIZED | | |
| 11 | GASKET, FULL FACE, 1 PLY, RUBBER | | |

NOTES:

1. NO COUPLING WILL BE PERMITTED BETWEEN ANGLE VALVE AND CORPORATION STOP EXCEPT WHEN THE LENGTH BETWEEN THE ELBOW AND THE CORPORATION STOP EXCEEDS 20'.
 2. NO TAP TO A MAIN SHALL BE WITHIN 18" OF A COUPLING OR WITHIN 18" OF ANOTHER TAP.
 3. UNDER NORMAL CONDITIONS THE WATER SERVICE SHALL EXTEND PERPENDICULAR TO THE CENTERLINE OF THE STREET FROM THE WATER MAIN TO THE ANGLE VALVE.
 4. METER IS TO BE INSTALLED BY THE CONTRACTOR AFTER METER BOX IS IN PLACE.
 5. ANGLE VALVE IS TO BE INSTALLED PLUMB AND SQUARE WITH THE CURB.
 6. IN NO CASE SHALL THE TUBE BE DISTORTED BEYOND ITS ELASTIC LIMIT.
 7. METER LAYING LENGTH IS MEASURED FROM THE FACE OF THE METER COUPLINGS. THE DISTANCE BETWEEN COUPLINGS SHALL NOT DEVIATE FROM THOSE SPECIFIED IN THE METER LAYING LENGTH TABLE.
 8. METER BOX IS TO BE POSITIONED SO THAT METER FACE IS HORIZONTALLY CENTERED WITHIN THE BOX. THE TOP OF THE BOX SHALL BE LEVEL AND FLUSH WITH THE TOP OF THE CURB.
 9. METER BOX SHALL HAVE 10' CLEARANCE FROM ANY WALL, OTHER UTILITIES OR SUB-SURFACE FACILITIES, UNLESS APPROVED BY WATER DIVISION.
- (A) HOUSE LINE PLUMBING CODE REQUIREMENTS.
- (B) JUMPER (AS NECESSARY) FOR TEMPORARY USE IN NEW TRACT DEVELOPMENT. THE LENGTH MUST CORRESPOND TO THE APPROPRIATE LENGTH OF THE METER TO BE INSTALLED BY CONTRACTOR AS SPECIFIED IN THE METER LAYING LENGTH TABLE ABOVE.

| DATE | REV. | DESCRIPTION |
|------|------|-------------|
| | | |
| | | |

NOTE: SEE STANDARD DETAIL W-21 FOR BEDDING, BACKFILL AND PAVING REQUIREMENTS.

CITY OF LA HABRA

2" DOMESTIC WATER SERVICE



APPROVED: *Christopher J. Johnson* DATE: *7/23/12*

STANDARD DETAIL W-6A

No. 3 - SP COVER

WT. 13 lbs.

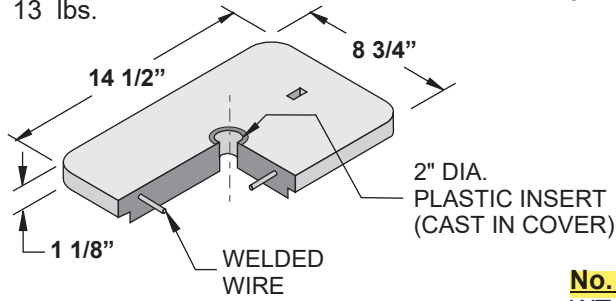

No. 3 MB - CONCRETE COVER

WT. 13 lbs.

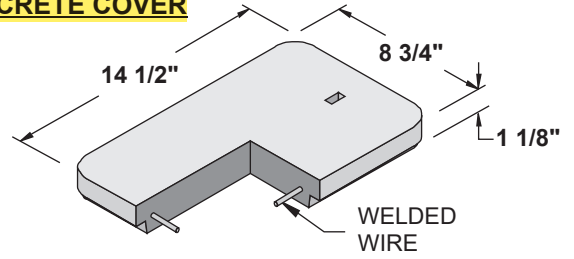

No. 3 - MA COVER

WT. 11 lbs.

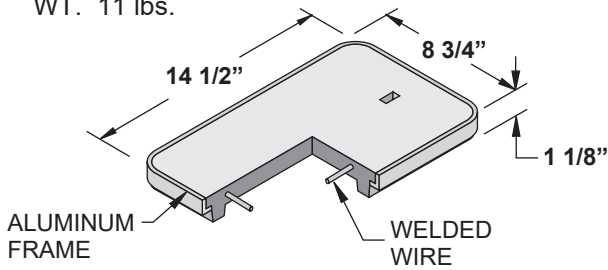

No. 3 MB - BODY

WT. 66 lbs.

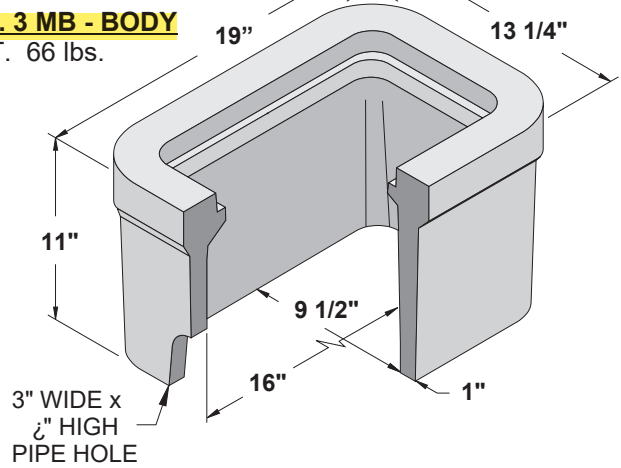

No. 3 - T CAST IRON COVER

WT. 16 lbs.

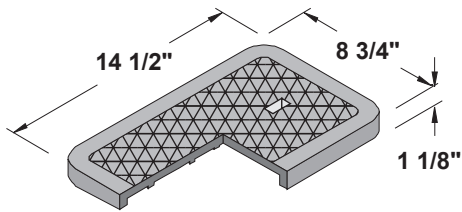

No. 3 MB - EXTENSION

WT. 66 lbs.

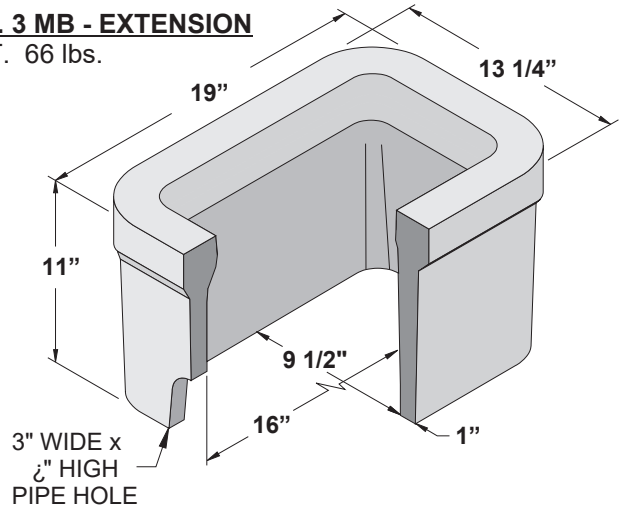

No. 3 - TL CAST IRON LOCKING COVER

WT. 16 lbs.

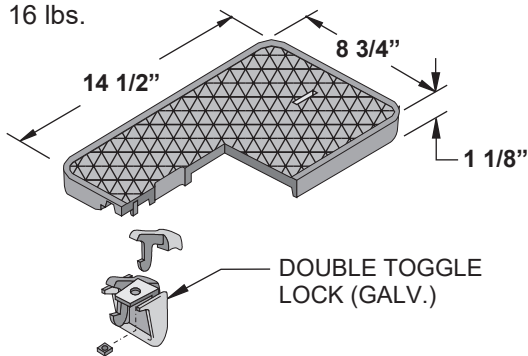

No. 3 MB - BASE

WT. 20 lbs.

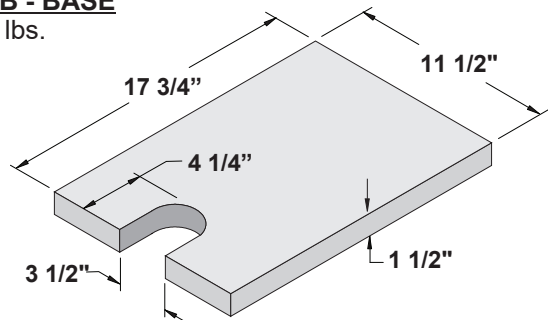

No. 3 - TG CAST IRON GRATE

WT. 19 lbs.

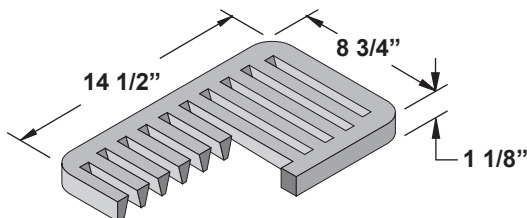

3 - 0 2

9 1/2" x 16" METER BOX
(for 3/4" WATER METER)

JENSEN
PRECAST EST. 1968

BROOKS 3MB

ORG. DWG. DATE
03-03-95

REV. DWG. DATE
02-14-20

APPENDIX “C”

RAILROAD ENCHROACHMENT PERMIT

REMS Project: 198673
Agency Project: Monte Vista Street
Start Date: 10/14/2023
End Date: 10/14/2024



BUILDING AMERICA®

Maintenance Consent Letter

| DOT | MP | Subdivision |
|---------|---------|--------------------|
| 761441X | 504.434 | Brea Chem Ind Lead |

Andrew Luna
CITY OF LA HABRA
110 East La Habra Boulevard
La Habra, CA 90631

It is the CITY OF LA HABRA’s (**Public Entity**) intention to perform sidewalk repair, subgrade repair, mill, overlay, reinstall existing pavement markings, and provide traffic control (**Work**) at the location(s) noted above. This letter serves as an acceptance by UNION PACIFIC RAILROAD COMPANY (**Railroad**) of the proposed Work to be performed.

If a contractor is to do any of the Work on Railroad’s property, then the Public Entity shall require its contractor to execute and return the attached Contractor Endorsement (**Endorsement**). Under no circumstances will Public Entity’s contractor be allowed on Railroad’s property without first executing the Endorsement.

This Consent Letter shall be valid for one year or until the Work is completed or this Consent Letter is revoked by the Railroad.

Prior to performing the Work, Contractor agrees to provide forty-five (45) days advance notice to the Railroad Representative identified below.

Leo Craig (817) 901-9560 – lcraig@olsson.com

Fiber Optics & Telecommunications (Call Before You Dig) – www.up.com/CBUD

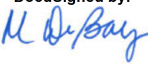
DocuSigned by:

10/16/2023
C56FA18B605E4A2...
Melinda S DuBay
Manager I
Engineering-Public Projects

REMS Project: 198673
Agency Project: Monte Vista Street
Consent Start Date: 10/14/2023

Contractor Endorsement

| DOT | MP | Subdivision |
|---------|---------|--------------------|
| 761441X | 504.434 | Brea Chem Ind Lead |

A. As a condition to entering upon Union Pacific Railroad Company (**Railroad**) property to perform sidewalk repair, subgrade repair, mill, overlay, reinstall existing pavement markings, and provide traffic control (**Work**) described in the Consent Letter, the contractor for CITY OF LA HABRA (**Public Entity**), by signing below, acknowledges and agrees to comply with and be bound by the Railroad Property Access Training (UP-PAT) and the General Terms and Provisions of the Endorsement that can be found at the links below.

Union Pacific Property Access Training (UP-PAT)

www.up.com/up-pat

Contractor Endorsement-General Terms and Provisions

www.up.com/ce-terms

Third-party Flagging Requirements

www.up.com/flagging

B. Upon request, all insurance documentation shall be provided to Railroad.

C. Fiber optics and telecommunication facilities can be present on Railroad property. Prior to performing work that has the potential to impact these facilities, the Agency or its contractor shall follow the procedures outlined on the Railroad webpage link below.

Fiber Optics & Telecommunications (Call Before You Dig) - www.up.com/CBUD

D. Prior to Performing the Work, Contractor agrees to provide forty-five (45) days advance notice to the Railroad Representative identified below.

Leo Craig (817) 901-9560 – lcraig@olsson.com

E. The terms of this Endorsement shall commence on the date of execution and continue for one (1) year or until such time as contractor has completed the Work. The Work may be terminated within 24 hours' notice by either party.

Signed Contractor Endorsement must be returned to the address below. No work may proceed until the terms of this endorsement have been met, and the executed endorsement and \$1,025 administrative fee is received.

Union Pacific Railroad Company
 ATTN: Engineering-Public Projects
 Maintenance Program
 1400 Douglas Street MS910
 Omaha, NE 68179

REMS Project: 198673
Agency Project: Monte Vista Street
Consent Start Date: 10/14/2023

Payment of the \$1,025 administrative fee must be submitted using one of the methods identified on the Bill included with this endorsement. If paying by check, submit the Bill with the check and mail to the Bank of America address on the Bill. For ACH or wire transfer payments, refer to the instructions provided on the Bill.

Failure to include the Bill Number with the payment will result in delays.

| | | | |
|--|---------------------------------------|-------------------------------------|---|
| Company Name | | | |
| Contact Name | | | |
| Address | | | |
| City, ST Zip | | | |
| Phone | Email | | |
| Contact Signature | Date | | |
| Payment Method Select Payment Type | <input type="checkbox"/> Check | <input type="checkbox"/> ACH | <input type="checkbox"/> Wire Transfer |

Union Pacific Railroad Company

BUILDING AMERICA™

CITY OF LA HABRA
110 EAST LA HABRA BOULEVARD
LA HABRA, CA 90631

Bill Number **328995139**
Contract Number 0198673
Audit Number 205343
Customer Number 57478
Folder Number 0170043
Bill Date 10/3/2023

For questions or comments please email REBILLING@up.com

Bill Description: Agency No: Monte Vista Street Resurfacing; DOT 761441X;
 Maintenance-Roadway. Effective date: 10/03/23

Location of Agreement: LA HABRA, CA

Primary Purpose of Agreement:

| Description | Period | | Amount |
|------------------------------|-----------|-----------|-------------------|
| | From | To | |
| Roadway-Contractor's ROE Fee | 10/3/2023 | 10/3/2023 | \$1,025.00 |
| Total Due: | | | \$1,025.00 |

.....
 To assure proper credit to your account,
 please remit payment using one of these methods:

ACH/Wire Information:

Union Pacific Acct nbr: 3752021457 (Checking)

Wire XFER ABA Routing nbr: 026009593

ACH PYMT ABA Routing nbr: 111000012

SEND Checks to:

Union Pacific Railroad Company

12567 Collections Center Drive

Chicago, IL 60693

Remittance Information:

Bill Number **328995139**

Audit Number 205343

Customer Number 57478

Folder Number 0170043

Payable Upon Receipt: **\$1,025.00**

Receiving Bank's Address

Bank of America

901 Main Street

Dallas, TX 75202

DUNS nbr: 00-699-1590

SWIFT Code: BOFAUS3N

Tax ID: 94-6001323

Network ID: 0136400825

Certificate Of Completion

Envelope Id: 679BD0223D634AB8AE53345A8F79A88A
Subject: 198673MCL 7857 761441X 2023-10-14 Agency Project: Monte Vista Street
Source Envelope:
Document Pages: 4
Certificate Pages: 5
AutoNav: Enabled
Enveloped Stamping: Enabled
Time Zone: (UTC-06:00) Central Time (US & Canada)

Status: Completed
Envelope Originator:
Leo Craig
1400 Douglas St MS910
Omaha, NE 68179
leo.craig@upcontractor.up.com
IP Address: 70.122.242.56

Record Tracking

Status: Original
10/14/2023 12:21:22 PM
Holder: Leo Craig
leo.craig@upcontractor.up.com

Location: DocuSign

Signer Events

Melinda DuBay
msdubay@up.com
Engineering-Industry & Public Projects-Manager I
Union Pacific Railroad
Security Level: Email, Account Authentication (None)

Signature

DocuSigned by:
[Signature Image]
C56FA18B605E4A2...
Signature Adoption: Uploaded Signature Image
Using IP Address: 69.58.206.114

Timestamp

Sent: 10/14/2023 12:22:43 PM
Viewed: 10/16/2023 10:27:44 AM
Signed: 10/16/2023 10:27:59 AM

Electronic Record and Signature Disclosure:
Accepted: 10/22/2019 2:45:20 PM
ID: b444c606-4c5b-4dd4-8676-6d8de04f75ac

In Person Signer Events

Signature

Timestamp

Editor Delivery Events

Status

Timestamp

Agent Delivery Events

Status

Timestamp

Intermediary Delivery Events

Status

Timestamp

Certified Delivery Events

Status

Timestamp

Andrew Luna
anluna@lahabraca.gov
Security Level: Email, Account Authentication (None)

[VIEWED]
Using IP Address: 64.183.111.178

Sent: 10/16/2023 10:28:01 AM
Viewed: 10/16/2023 2:40:11 PM

Electronic Record and Signature Disclosure:
Accepted: 10/16/2023 2:40:11 PM
ID: 76aed8f9-bb61-4e21-89e4-a3f705c74eca

Carbon Copy Events

Status

Timestamp

Doug Woods
dwoods@olsson.com
Security Level: Email, Account Authentication (None)

[COPIED]

Sent: 10/16/2023 10:28:01 AM

Electronic Record and Signature Disclosure:
Not Offered via DocuSign

Leo Craig
lcraig@olsson.com
Security Level: Email, Account Authentication (None)

[COPIED]

Sent: 10/16/2023 10:28:01 AM

| Carbon Copy Events | Status | Timestamp |
|--------------------|--------|-----------|
|--------------------|--------|-----------|

Electronic Record and Signature Disclosure:
Accepted: 7/14/2023 10:16:16 AM
ID: 4abfd857-4e2e-4692-9205-70e7053209b2

Peyton Lee
plee2@olsson.com

COPIED

Sent: 10/16/2023 10:28:01 AM

Security Level: Email, Account Authentication (None)

Electronic Record and Signature Disclosure:
Accepted: 5/4/2023 8:06:01 AM
ID: 91fc6912-59e0-4f99-9f0c-00757c5bad5f

Andrew Luna
anluna@lahabraca.gov

COPIED

Sent: 10/16/2023 2:40:11 PM

Security Level: Email, Account Authentication (None)

Electronic Record and Signature Disclosure:
Accepted: 10/16/2023 2:40:11 PM
ID: 76aed8f9-bb61-4e21-89e4-a3f705c74eca

| Witness Events | Signature | Timestamp |
|----------------|-----------|-----------|
|----------------|-----------|-----------|

| Notary Events | Signature | Timestamp |
|---------------|-----------|-----------|
|---------------|-----------|-----------|

| Envelope Summary Events | Status | Timestamps |
|-------------------------|--------|------------|
|-------------------------|--------|------------|

| | | |
|---------------------|------------------|------------------------|
| Envelope Sent | Hashed/Encrypted | 10/14/2023 12:22:43 PM |
| Certified Delivered | Security Checked | 10/16/2023 2:40:11 PM |
| Signing Complete | Security Checked | 10/16/2023 10:27:59 AM |
| Completed | Security Checked | 10/16/2023 2:40:11 PM |

| Payment Events | Status | Timestamps |
|----------------|--------|------------|
|----------------|--------|------------|

| Electronic Record and Signature Disclosure |
|--|
|--|

ELECTRONIC RECORD AND SIGNATURE DISCLOSURE

From time to time, Union Pacific Corporation (we, us or Company) may be required by law to provide to you certain written notices or disclosures. Described below are the terms and conditions for providing to you such notices and disclosures electronically through the DocuSign system. Please read the information below carefully and thoroughly, and if you can access this information electronically to your satisfaction and agree to this Electronic Record and Signature Disclosure (ERSD), please confirm your agreement by selecting the check-box next to 'I agree to use electronic records and signatures' before clicking 'CONTINUE' within the DocuSign system.

Getting paper copies

At any time, you may request from us a paper copy of any record provided or made available electronically to you by us. You will have the ability to download and print documents we send to you through the DocuSign system during and immediately after the signing session and, if you elect to create a DocuSign account, you may access the documents for a limited period of time (usually 30 days) after such documents are first sent to you. After such time, if you wish for us to send you paper copies of any such documents from our office to you, you will be charged a \$0.00 per-page fee. You may request delivery of such paper copies from us by following the procedure described below.

Withdrawing your consent

If you decide to receive notices and disclosures from us electronically, you may at any time change your mind and tell us that thereafter you want to receive required notices and disclosures only in paper format. How you must inform us of your decision to receive future notices and disclosure in paper format and withdraw your consent to receive notices and disclosures electronically is described below.

Consequences of changing your mind

If you elect to receive required notices and disclosures only in paper format, it will slow the speed at which we can complete certain steps in transactions with you and delivering services to you because we will need first to send the required notices or disclosures to you in paper format, and then wait until we receive back from you your acknowledgment of your receipt of such paper notices or disclosures. Further, you will no longer be able to use the DocuSign system to receive required notices and consents electronically from us or to sign electronically documents from us.

All notices and disclosures will be sent to you electronically

Unless you tell us otherwise in accordance with the procedures described herein, we will provide electronically to you through the DocuSign system all required notices, disclosures, authorizations, acknowledgements, and other documents that are required to be provided or made available to you during the course of our relationship with you. To reduce the chance of you inadvertently not receiving any notice or disclosure, we prefer to provide all of the required notices and disclosures to you by the same method and to the same address that you have given us. Thus, you can receive all the disclosures and notices electronically or in paper format through the paper mail delivery system. If you do not agree with this process, please let us know as described below. Please also see the paragraph immediately above that describes the consequences of your electing not to receive delivery of the notices and disclosures electronically from us.

How to contact Union Pacific Corporation:

You may contact us to let us know of your changes as to how we may contact you electronically, to request paper copies of certain information from us, and to withdraw your prior consent to receive notices and disclosures electronically as follows:

To contact us by phone call: (402) 544-3331

To contact us by email send messages to: acampbe@upcontractor.up.com

To advise Union Pacific Corporation of your new email address

To let us know of a change in your email address where we should send notices and disclosures electronically to you, you must send an email message to us at acampbe@upcontractor.up.com and in the body of such request you must state: your previous email address, your new email address. We do not require any other information from you to change your email address.

If you created a DocuSign account, you may update it with your new email address through your account preferences.

To request paper copies from Union Pacific Corporation

To request delivery from us of paper copies of the notices and disclosures previously provided by us to you electronically, you must send us an email to acampbe@upcontractor.up.com and in the body of such request you must state your email address, full name, mailing address, and telephone number. We will bill you for any fees at that time, if any.

To withdraw your consent with Union Pacific Corporation

To inform us that you no longer wish to receive future notices and disclosures in electronic format you may:

- i. decline to sign a document from within your signing session, and on the subsequent page, select the check-box indicating you wish to withdraw your consent, or you may;
- ii. send us an email to acampbe@upcontractor.up.com and in the body of such request you must state your email, full name, mailing address, and telephone number. We do not need any other information from you to withdraw consent.. The consequences of your withdrawing consent for online documents will be that transactions may take a longer time to process..

Required hardware and software

The minimum system requirements for using the DocuSign system may change over time. The current system requirements are found here: <https://support.docusign.com/guides/signer-guide-signing-system-requirements>.

Acknowledging your access and consent to receive and sign documents electronically

To confirm to us that you can access this information electronically, which will be similar to other electronic notices and disclosures that we will provide to you, please confirm that you have read this ERSD, and (i) that you are able to print on paper or electronically save this ERSD for your future reference and access; or (ii) that you are able to email this ERSD to an email address where you will be able to print on paper or save it for your future reference and access. Further, if you consent to receiving notices and disclosures exclusively in electronic format as described herein, then select the check-box next to ‘I agree to use electronic records and signatures’ before clicking ‘CONTINUE’ within the DocuSign system.

By selecting the check-box next to ‘I agree to use electronic records and signatures’, you confirm that:

- You can access and read this Electronic Record and Signature Disclosure; and
- You can print on paper this Electronic Record and Signature Disclosure, or save or send this Electronic Record and Disclosure to a location where you can print it, for future reference and access; and
- Until or unless you notify Union Pacific Corporation as described above, you consent to receive exclusively through electronic means all notices, disclosures, authorizations, acknowledgements, and other documents that are required to be provided or made available to you by Union Pacific Corporation during the course of your relationship with Union Pacific Corporation.

APPENDIX “D”

UTILITY REQUIREMENTS

SCG Transmission General Requirements



Transmission Technical
Services Department

9400 Oakdale Ave
Chatsworth, CA 91311
SC9314

November 11, 2022

Andrew Luna
Public Works Department
anluna@lahabra.gov

Subject: La Habra-Monte Vista Street Rehabilitation Project

DCF: 2121-22-2000

The following are general requirements provided when performing work or planning projects near SoCalGas high pressure lines. Please review requirements along with project plans and notify SoCalGas Transmission Department about any questions or conflicts.

It is highly recommended that communication is maintained with SoCalGas to address all conflicts. Depending on the specific scope of your project there may be less or more requirements that need to be discussed regarding your project.

- 1- Consideration must be given to the safety of our pipeline(s) during all project stages.
- 2- SoCalGas must have continuous and uninterrupted access to the pipeline(s) and easement(s). In addition, SoCalGas conducts routine patrols and surveys of the pipeline(s); SoCalGas needs drivable access along the pipeline(s)/easement(s).
- 3- Buried pipelines must have a minimum cover of 3 feet and a maximum cover of 7 feet below finished grade. No change of grade whatsoever, even within these parameters, shall be made without prior approval of SoCalGas.
- 4- Prior to SoCalGas approving encroachment onto its easement(s), SoCalGas must be furnished with final grading plans showing the depth of the pipeline(s) below the existing surface and the depth of the pipeline(s) below the proposed finished grade. These elevations must meet SoCalGas' requirements for buried pipelines.
- 5- No permanent structures, such as buildings, block walls, foundations, gates, etc., shall be constructed within the easement or over the pipeline(s).

SCG Transmission General Requirements

- 6- There shall be no planting of trees or other deep-rooted plants within the easement(s) or over the pipeline(s).
- 7- Substructures shall cross perpendicular to the easement(s). Substructure crossings must provide a minimum of 18-inches vertical clearance from the pipeline(s). Additional separation is required for leach lines, fuel lines, etc.
- 8- Parallel encroachments within the easement(s) are prohibited. In areas where a parallel substructure is being constructed outside of the easement(s), SoCalGas requires five feet of separation, with three feet of undisturbed fill, in order to protect the integrity of our facilities and allow the facilities to be safely accessed during inspection, maintenance, and repair. Additional separation may be needed for leach lines, fuel lines, high voltage electric, etc.
- 9- All encroachments onto SoCalGas' easement(s) must have written approval of SoCalGas prior to construction or encroaching onto the easement(s).
- 10- All work within the SoCalGas easement(s) and/or within 10 feet of the pipeline(s) must be witnessed by a SoCalGas representative, and no work will be allowed without the SoCalGas representative on site.
- 11- No heavy equipment shall cross the pipeline(s) without SoCalGas' approval. Additional protective measures may be required where heavy equipment is expected to cross the pipeline(s).
- 12- No mechanical equipment shall operate within three horizontal feet of the pipeline(s), and any closer work must be performed by hand.
- 13- No mechanical equipment shall operate within two vertical feet of the pipeline(s), and any closer work must be performed by hand.
- 14- Buried pipeline(s) shall not be left exposed, and exposed pipeline(s) shall not be buried, without prior inspection and approval by SoCalGas. If the pipeline(s) are exposed during construction (e.g. substructure crossings, etc.), the pipeline must be backfilled with sand or zero-sack slurry only.
- 15- No vibratory compaction is permitted over the pipeline(s). In rare cases, vibratory compaction may be approved by SoCalGas' Engineering Department following review of detailed site conditions, pipeline data, and equipment specifications.
- 16- All contractors and subcontractors must be notified of the presence of the pipeline(s).
- 17- Contractors and subcontractors must call DigAlert (811) at least 2 working days prior to construction, grading, or excavation.
- 18- Once approved, encroachments within SoCalGas' easement(s) shall be documented in an easement amendment or other document, as deemed appropriate by SoCalGas' Land Services Department.

SCG Transmission General Requirements

In addition to the previous requirements, SoCalGas recommends the following:

- 19- Potholes should be made, as necessary, to establish the horizontal and vertical alignment of the pipeline(s) within the project area. This information should be indicated on the plans, as needed. CAUTION: SoCalGas personnel must be present during potholing operations. Arrangements for SoCalGas personnel to stand by during potholing activities can be made by calling DigAlert at 811.
- 20- Consideration should be given to building setbacks from the easement lines. A minimum 15-foot setback is recommended whenever possible.
- 21- All potential buyers or tenants of the property should be made aware of the presence of the pipeline(s) and easement restrictions.

Best Regards,

SoCalGas Transmission Technical Services



Transmission Technical
Services Department

9400 Oakdale Ave
Chatsworth, CA 91311
SC9314

November 11, 2022

Andrew Luna
Dawson Surveying, INC
robertd@dsils.com

Subject: La Habra-Monte Vista Street Rehabilitation Project

DCF: 2121-22-2000

Southern California Gas Company (SoCalGas) Transmission Department operates and maintains high-pressure natural gas transmission pipeline(s) in the vicinity of your project. The pipeline is shown on the attached map(s). Please note, only the high-pressure transmission pipeline information is current on these atlas prints.

Our Gas Distribution Department may have other gas facilities within your project area. To assure no conflict with the SoCalGas' distribution pipeline system, please contact

AtlasRequests/WillServeAnaheim@semprautilities.com.

This is only a response to a gas facility map request; a review of potential conflicts associated with your request has not been conducted. Consequently, **this letter does not constitute clearance for any construction work near or around SoCalGas' pipeline(s)**. As your project plans are developed, you must notify SoCalGas - Gas Transmission Department regarding the improvements that are proposed near our pipeline(s) and within our easement(s) before you begin any construction, including potholing. In doing so, please allow sufficient time as there may be certain requirements that need to be incorporated into your project's design and could significantly affect your project construction schedule.

Best Regards,
Emiliano Ibanez
Pipeline Planning Assistant
SoCalGas Transmission Technical Services
SoCalGasTransmissionUtilityRequest@semprautilities.com



ZENITH ENERGY WEST COAST TERMINALS LLC

18000 Studebaker Rd., Suite 960
Cerritos, CA 90703

November 4, 2022

526-0002.000

Andrew Luna
City of La Habra, Public Works Department
110 E. La Habra Blvd.
La Habra, CA 90631

VIA Email – anluna@lahabracalifornia.gov

RE: La Habra-Monte Vista St Rehab Project

Dear Andrew,

As requested by your email sent October 27, 2022 to Zenith Energy West Coast Terminals LLC, enclosed is information for one pipeline within the area of the above-described project. Please see the attached Google Earth aerial and pipeline alignment sheet.

| Pipeline Name | Pipeline General Location | Alignment Sheets |
|------------------|---|------------------|
| 12" OOS Line 526 | In Lambert Avenue crossing Monte Vista Street | 5194885 |

Also enclosed is a copy of our Construction Requirements to be followed when working within a Zenith easement area.

When construction is involved within the area of this pipeline, please be advised that at least 48 hours prior to the start of construction, your contractor should contact Zenith Energy's Corrosion/Line Rider Lead James Foster at (562) 572-2501 to arrange a job site pre-construction meeting with a Zenith Inspector. This notice is requested in addition to notification through Underground Service Alert.

Please make sure your contractor does not grind over or pave over any Zenith manholes/lids in conjunction with this work. These manholes are used to determine the level of cathodic protection on a pipeline and to attach a Metrotech signal detector to assist in determining the location of the pipeline. Zenith would appreciate their addition to the construction notes as "pipeline cathodic protection manholes".

If you have any further questions, please call me at (562) 263-3930 or call Lloyd Wall at (562) 263-3946.

Very truly yours,

Steven Franks
Area Manager
Zenith West Coast Terminals LLC

Enclosures

cc: James Foster





**ZENITH ENERGY WEST
COAST TERMINALS LLC**

**GENERAL REQUIREMENTS FOR CROSSING
ZENITH ENERGY WEST COAST TERMINALS LLC PIPELINES
(November 30, 2020)**

We appreciate the opportunity to work with you and your company in the early planning stages of your development activity. Zenith Energy West Coast Terminals has General Requirements that are applicable to all of our pipelines in this geographic area.

Working together and following our pipeline safety requirements will help:

- Protect the safety of your employees, the environment and the surrounding community;
- Reduce the risk of damage to our pipeline and related facilities;
- Ensure an adequate work area for future pipeline maintenance and/or repair work;
- Enable effective corrosion protection for our pipeline; and
- Minimize any conflict that may arise.

AT NO COST TO THE CONTRACTOR, A ZENITH REPRESENTATIVE WILL ERECT TEMPORARY FLAGS MARKING THE PIPELINE LOCATION AND SHALL BE PRESENT DURING ALL ACTIVE WORK PERIODS TO OBSERVE EXCAVATION OR OTHER CONSTRUCTION ACTIVITIES NEAR THE PIPELINE.

ANY WORK PERFORMED NEAR THE PIPELINE WITHOUT THE PRESENCE OF A ZENITH REPRESENTATIVE WILL NECESSITATE THAT THE PIPELINE BE EXPOSED FOR INSPECTION AND NEEDED REPAIRS PERFORMED AT THE CONTRACTOR'S OR RESPONSIBLE PARTY'S COST.

DESIGN AND CONSTRUCTION

1. **ALL PIPELINES, UTILITY LINES** and other underground facilities constructed across Zenith owned or operated pipeline must be installed with a minimum vertical separation of 24 inches between structures. All facilities crossing a Zenith pipeline shall be made of, or encased in, steel pipe with threaded or welded joints the entire width of Zenith's right of way. Horizontal separations will be determined on a case-by-case basis. Electrical conduit and cables are excluded, please refer to paragraph 2. All work and cleanup will be conducted in a manner acceptable to Zenith's on-site representative. When a new steel crossing is installed near an existing Zenith facility, a test station will need to be added. The test leads will be identified and then brought into either a shared road box or a post mounted test station.
2. **ALL UNDERGROUND ELECTRICAL CABLES** shall be installed with a minimum vertical separation of 24 inches between structures with all plans, work and cleanup conducted in a manner acceptable to Zenith's on-site representative. Horizontal separation will be determined on a case-by-case basis. In addition, the electrical cable must be enclosed in conduit (steel or Schedule 80 PVC). It should be covered with **red** reinforced concrete with a minimum width of 6 inches on each side and above the conduit, for the entire width of Zenith's right of way.
3. **ALL UNDERGROUND FIBER OPTIC CABLES** shall be installed with a minimum vertical separation of 24 inches between structures with all plans, work and cleanup conducted in a manner acceptable to Zenith's on-site representative. Horizontal separation will be determined on a case-by-case basis. In addition, the fiber optic cable must be enclosed in conduit (steel or Schedule 80 PVC). It should be covered with **red** reinforced concrete with a minimum width of 6 inches on each side and above the conduit, for the entire width of Zenith's right of way.
4. **ALL PROPOSED ROADS, STREETS, OR DRIVEWAYS** shall be constructed with a minimum cover of 48 inches, including the sub-grade, as measured from the top of the Zenith pipeline to the bottom of the pavement (road, street, or driveway) outlined below. If a Zenith pipeline will require adjustment to accommodate a roadway, street, or driveway crossing, the cost of any such lowering or relocation shall be borne by the party or parties requesting the adjustment. With each request involving roads, streets, or driveways, Zenith will reserve the right to excavate to expose and inspect its pipeline(s) to determine the need for pipe replacement, full encasement, or heavy wall pipe. The cost of this activity will be at the expense of the requesting party. After paving activities are complete, any road boxes or manholes will be brought to the new grade of the street.

A. **PIPELINE MINIMUM COVER REQUIREMENTS**

1. 48 inches from bottom of pavement under a road, street or driveway to the top of Zenith's pipeline.
2. 36 inches under all other surfaces to the top of Zenith's pipeline.

- B. Any concrete paving (other than for road, street or driveway crossings of a Zenith pipeline) i.e. a parking lot should it be approved to be constructed over the Zenith's pipeline by a Zenith representative shall (a) be reinforced, (b) not exceed 4 inches in thickness, (c) be sectioned in 10 foot by 15 foot panels (15' dimension shall be perpendicular to the pipeline) with appropriate expansion joints, (d) containing lifting rings, and (e) conform to the minimum cover requirements stipulated above.
- C. Zenith shall have the right to cut and remove any pavement or other surface structures now or hereafter located over or across a Zenith pipeline, without prior notice or any obligation to repair, replace, resurface or dispose of removed material, for the purpose of exercising any rights granted to Zenith under the pipeline rights of way and easements.
5. **ANY DRAINAGE DITCHES** shall be constructed with a minimum cover, and measured from the lowest point in the ditch, to the top of pipe as follows:
1. Concrete lined – 12 inches.
 2. Unlined – 36 inches.

Any drainage canals shall be constructed with a minimum of 60 inches of cover below the ultimate flow line.

6. **TEMPORARY (HAUL) ROAD** crossings shall be constructed with a minimum ground cover (as measured from the surface of the road to the top of the pipeline) of **5-feet**. A temporary earthen berm may be constructed to meet this requirement. Where it is necessary for heavy equipment to cross the pipeline, additional measures may be needed to effectively distribute the weight of such equipment, for example, installing additional cover, timber matting and/or a temporary bridge for passage over the pipeline.
7. **LAKES OR OTHER BODIES OF WATER** shall not be constructed over the pipeline or within the boundaries of the pipeline easement. Additionally, the surface cannot be developed or changed in any way that would cause rainwater or runoff to collect on the pipeline right-of-way.
8. **DIRECTIONAL DRILLING OR BORING** shall require additional damage prevention measures, whether installing a crossing or otherwise conducting such operations within **25-feet** of the pipeline. It is Zenith's option whether peepholes or sheet piling be installed to an elevation lower than the pipeline, before drilling/boring to help ensure its protection. Zenith requires continuous tracking of the drilling head as well as using a physical technique (such as probing) to ascertain the exact location of the head before it crosses the Zenith pipeline. Zenith may also require that the pipeline be exposed when near drill/bore entry or exit points.

9. If Zenith determines it is necessary to lower, encase or otherwise adjust a Zenith pipeline because of the landowner's (developer's, etc.) construction activity, the landowner or developer shall reimburse Zenith for the cost of lowering, encasement or other adjustments.
10. Please notify Zenith's Corrosion/Line Rider Lead James Foster at (562) 263-3924 at least two (2) business days prior to commencing any excavating or construction activity in the vicinity of any Zenith pipeline. **California One-Call must also be notified before starting any excavation or construction activity.** If you are unable to contact the above Zenith representative, contact the Pipeline Control Center, and the information will be relayed.

Pipeline Control Center
24 Hours
(281) 397-3766

11. No excavating or construction activity shall be conducted within 25 feet of any Zenith pipeline or related facility in the absence of a Zenith representative. All plans that are submitted to Zenith for approval shall have the two phone numbers above, along with the two (2) business days notice of commencement, imprinted on plans.
12. Any contractor, developer, geophysical entity etc., planning blasting operations within 500 feet of any Zenith pipeline or facility shall submit a blasting plan to Zenith for approval. This plan will include hole depth, diameter, spacing, burden, delay times, maximum charge weight per delay, sequence, explosive type and blast zone relative to the Zenith pipeline or facility. Under NO circumstances will blasting or seismic shot holes be allowed within 100 feet of any Zenith pipeline.
13. No signs, billboards, monuments, buildings, power poles, structures, manholes, parking lots, shrubbery, or trees shall be located within a Zenith right of way and easement area so that the pipeline can be maintained without damaging these structures or being impeded by them.
14. No excavation shall be made on land adjacent to any Zenith pipeline which will in any way impair, withdraw lateral support, cause subsidence, create the accumulation of water, or cause damage to the Zenith pipeline right of way.
15. No fence shall be placed across a Zenith right of way without written permission from Zenith. If fences are permitted, 14-foot gates must be installed on the right of way, and keys to any installed locks shall be provided to Zenith.
16. Side cutters shall be removed from the bucket of excavation equipment, and a bar shall be installed across the teeth during excavation in the vicinity of any Zenith pipeline.
17. No paving is to be placed over any Zenith right of way without prior written permission from Zenith.

18. Any damage to existing Zenith pipelines, facilities, pipeline insulation and/or coating, casing, markers and/or signs, test leads, vent pipes, fences, gates and/or any other associated pipeline apparatus resulting from the installation, construction, maintenance or operations of any third party facilities crossing Zenith's pipelines shall be repaired to Zenith's satisfaction or replaced at the sole cost and expense by the responsible party within 15 days after the damage has occurred.

19. All written requests should be supported with plans and forwarded to:

Attn: Area Manager
Zenith Energy West Coast Terminals LLC
18000 Studebaker Rd., St. 960
Cerritos, CA 90703



THE METROPOLITAN WATER DISTRICT
OF SOUTHERN CALIFORNIA

Office of the General Manager

MWD Lower Feeder
Sta. 1730+00 to 1731+00
R/W Parcel No. 1002-4-43 (Fee)
Substructures Job No. 2016-22-023

September 6, 2023

Andrew Luna, P.E.
Associate Civil Engineer
City of La Habra Public Works Department
110 East La Habra Boulevard
La Habra, CA 90631
anluna@lahabraca.gov

Dear Andrew:

Monte Vista Pavement Improvements

Thank you for your email dated August 14, 2023, submitting a print of your plans (Sheet 4 of 13) for the proposed pavement improvements project located along Monte Vista Street north of Lambert Road in the city of La Habra. Included with your email was a "Right of Entry Permit" form.

We have reviewed your submitted plans, and our comments and requirements are as follows:

1. Metropolitan's 97-inch-inside-diameter welded steel Lower Feeder pipeline and Coyote Creek Power Plant Inlet pipeline are located on Lambert Road and Monte Vista Street in the vicinity of the proposed project area. Enclosed is a print of a Google Earth map and prints of our Drawings B-12561 and B-67491, for your information and use.
2. We have no objections to the proposed removal and replacement of 4-inch thick concrete sidewalk panels and a driveway approach within our fee property right-of-way along Monte Vista Street, as shown on Sheet 4 of 13 of your plans.

However, appropriate rights must be obtained from Metropolitan for the proposed improvements within our fee property right-of-way. An application for the use of our fee property can be found here:

https://www.mwdh2o.com/media/17781/471_land_use_request_form_revised.pdf.

Please contact Kevin Webb of our Real Property and Development and Land

Andrew Luna, P.E.
Page 2
September 6, 2023

Management Unit, via email at kwebb@mwdh2o.com, regarding the process of obtaining the necessary entry permit and license documentation for any work within the limits of our fee right-of-way.

3. We also have no objections to the proposed removal and replacement of 5 inches of asphalt concrete pavement along Monte Vista Street since the construction limits are outside our right-of-way and away from our pipelines.
4. Please note the stockpiling of materials or storage of equipment within Metropolitan's fee property right-of-way is not allowed.
5. We also request that a stipulation be added to your plans and/or specifications to notify the OC System Protection Office of our Water System Operations Group, telephone (714) 577-5084 or email ocsystemprotection@mwdh2o.com, at least two working days prior to starting any work in the vicinity of our facilities.

We are returning a print of your plans (Sheet 4 of 13), stamped: "REVIEWED – CORRECTIONS NOTED – NO RESUBMITTAL REQUIRED."

Facilities constructed within Metropolitan's fee property right-of-way shall be subject to the paramount right of Metropolitan to use the fee property for the purpose for which it was acquired. If at any time Metropolitan or its assigns should, in the exercise of their rights, find it necessary to remove any of the facilities from the fee property, such removal and replacement shall be at the expense of the owner of the facility.

For any further correspondence with Metropolitan relating to this project, please refer to the Substructures Job Number shown in the upper right-hand corner of the first page of this letter. Should you require any additional information, please contact Mannu Singh at (213) 217-6961 or by email at msingh@mwdh2o.com.

Sincerely,



for Francisco Flores, P.E.
Manager, Substructures Team

MS
DOC#: 2016-22-023

Enclosures (4)

Andrew Luna, P.E.
Page 3
September 6, 2023

bcc: M. Singh
OC System Protection Office w/ plans
Substructures Folder w/ plans



THE METROPOLITAN WATER DISTRICT
OF SOUTHERN CALIFORNIA

Office of the General Manager

MWD Lower Feeder
Sta. 1729+00 to 1731+00
Substructures Job No. 2016-22-016
R/W Parcel No. 1002-4-41 and -43

November 16, 2022

Andrew Luna, P.E.
Assistant Civil Engineer
Public Works Department
Engineering Division
City of La Habra
110 East La Habra Boulevard
La Habra, CA 90631
anluna@lahabracal.gov

Dear Andrew:

La Habra – Monte Vista Street Rehabilitation Project – Utility Request

We received your email, dated November 1, 2022, and utility request letter, dated October 17, 2022, submitting a map showing the location of your proposed street rehabilitation project along Monte Vista Street, between La Habra Boulevard and Lambert Road, in the city of La Habra.

As shown on the enclosed map, Metropolitan's 97-inch-inside-diameter welded steel Lower Feeder pipeline with appurtenant manhole structure, 61-inch-inside-diameter welded steel Coyote Creek Power Plant inlet pipeline and accompanying varied-width fee and permanent easement rights-of-way are generally located at the intersection of Monte Vista Street and Lambert Road within the proposed project area.

In addition, our Coyote Creek Power Plant and Pressure Control System are located on the northwest corner of Monte Vista Street and Lambert Road, adjacent to the proposed project area.

We are transmitting a copy of our "Guidelines for Improvements and Construction Projects Proposed in the Area of Metropolitan's Facilities and Rights-of-Way" and prints of our Drawings B-12561 and B-67491 and Right-of-Way Map 1002-4 for your information and use.

We request that our facilities and rights-of-way be fully shown and identified as Metropolitan's on your project plans and that prints of the preliminary plans be submitted for our review and written approval as they pertain to our facilities. All applicable portions of the enclosed guidelines should be incorporated into your plans.

Andrew Luna, P.E.
Page 2
November 16, 2022

We also request that a stipulation be added to your plans and/or specifications to notify the Orange County System Protection Office of our Water System Operations Group, (714) 577-5084, at least two working days prior to performing any work in the vicinity of our facilities.

For any further correspondence with Metropolitan relating to this project, please refer to the Substructures Job Number shown in the upper right-hand corner of the first page of this letter. Should you require any additional information, please contact Marilyn Duarte at (213) 217-7059 or by email at mduarte@mwdh2o.com.

Sincerely,

Mannu Singh

Mannu Singh, P.E.
Substructures Team

MD
DOC#: 2016-22-023

Enclosures (5)

**Guidelines for
Improvements and Construction Projects Proposed
in the Area of
Metropolitan's Facilities and Rights-of-Way**

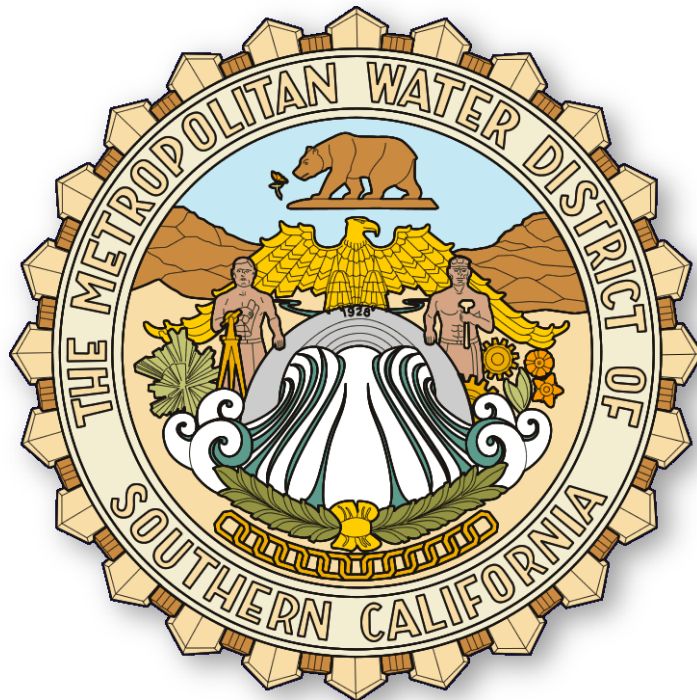

July 2018

Prepared By:
The Metropolitan Water District of Southern California
Substructures Team, Engineering Services
700 North Alameda Street
Los Angeles, California 90012

Copyright © 2018 by *The Metropolitan Water District of Southern California*.

Additional Copies: To obtain a copy of this document, please contact the Engineering Services Group, Substructures Team.

Disclaimer

Metropolitan assumes no responsibility for the accuracy of the substructure information herein provided. The user assumes responsibility for verifying substructure locations before excavating and assumes all liability for damage to Metropolitan's facilities as a result of such excavation. Additionally, the user is cautioned to conduct surveys and other field investigations as deemed prudent, to assure that project plans are correct. The appropriate representative from Metropolitan must be contacted at least two working days, before any work activity in proximity to Metropolitan's facilities.

It generally takes 30 days to review project plans and provide written responses. Metropolitan reserves the right to modify requirements based on case-specific issues and regulatory developments.

PUBLICATION HISTORY:

Initial Release

July 2018

Table of Contents

| | | |
|------|---|---|
| 1.0 | GENERAL INFORMATION | 1 |
| 1.1 | Introduction | 1 |
| 1.2 | Submittal and Review of Project Plans/Utilities and Maps | 1 |
| 1.3 | Identification of Metropolitan’s Facilities and Rights-of-Way | 3 |
| 2.0 | General Requirements | 3 |
| 2.1 | Vehicular Access | 3 |
| 2.2 | Fences | 3 |
| 2.3 | Driveways and Ramps | 3 |
| 2.4 | Walks, Bike Paths, and Trails | 3 |
| 2.5 | Clear Zones | 4 |
| 2.6 | Slopes | 4 |
| 2.7 | Structures | 4 |
| 2.8 | Protection of Metropolitan Facilities | 4 |
| 2.9 | Potholing of Metropolitan Pipelines | 4 |
| 2.10 | Jacked Casings or Tunnels | 4 |
| 3.0 | Landscaping | 5 |
| 3.1 | Plans | 5 |
| 3.2 | Drought-Tolerant Native and California Friendly Plants | 5 |
| 3.3 | Trees | 5 |
| 3.4 | Other Vegetation | 6 |
| 3.5 | Irrigation | 6 |
| 3.6 | Metropolitan Vehicular Access | 6 |
| 4.0 | General Utilities | 6 |
| 4.1 | Utility Structures | 6 |
| 4.2 | Utility Crossings | 6 |
| 4.3 | Longitudinal Utilities | 7 |
| 4.4 | Underground Electrical Lines | 7 |
| 4.5 | Fiber Optic Lines | 7 |
| 4.6 | Overhead Electrical and Telephone Lines | 7 |
| 4.7 | Sewage Disposal Systems | 7 |
| 4.8 | Underground Tanks | 8 |
| 5.0 | Specific Utilities: Non-Potable Utility Pipelines | 8 |
| 6.0 | Cathodic Protection/Electrolysis Test Stations | 8 |
| 6.1 | Metropolitan Cathodic Protection | 8 |
| 6.2 | Review of Cathodic Protection Systems | 8 |
| 7.0 | Drainage | 9 |
| 7.1 | Drainage Changes Affecting Metropolitan Rights-of-Way | 9 |
| 7.2 | Metropolitan’s Blowoff and Pumpwell Structures | 9 |
| 8.0 | Grading and Settlement | 9 |

Table of Contents

| | | |
|------|--|----|
| 8.1 | Changes in Cover over Metropolitan Pipelines..... | 9 |
| 8.2 | Settlement | 9 |
| 9.0 | Construction Equipment | 10 |
| 9.1 | Review of Proposed Equipment..... | 10 |
| 9.2 | Equipment Restrictions | 10 |
| 9.3 | Vibratory Compaction Equipment..... | 10 |
| 9.4 | Equipment Descriptions | 10 |
| 10.0 | Excavations Close to Metropolitan Facilities..... | 11 |
| 10.1 | Shoring Design Submittal..... | 11 |
| 10.2 | Shoring Design Requirements | 11 |
| 11.0 | Support of Metropolitan Facilities..... | 11 |
| 11.1 | Support Design Submittal | 11 |
| 11.2 | Support Design Requirements | 11 |
| 12.0 | Backfill..... | 12 |
| 12.1 | Metropolitan Pipeline Not Supported..... | 12 |
| 12.2 | Metropolitan Pipeline Partially Exposed | 12 |
| 12.3 | Metropolitan Cut and Cover Conduit on Colorado River Aqueduct (CRA) | 12 |
| 13.0 | Piles | 13 |
| 13.1 | Impacts on Metropolitan Pipelines | 13 |
| 13.2 | Permanent Cast-in-place Piles..... | 13 |
| 14.0 | Protective Slabs for Road Crossings Over Metropolitan Pipelines | 13 |
| 15.0 | Blasting | 13 |
| 16.0 | Metropolitan Plan Review Costs, Construction Costs and Billing..... | 14 |
| 16.1 | Plan Review Costs..... | 14 |
| 16.2 | Cost of Modification of Facilities Performed by Metropolitan | 14 |
| 16.3 | Final Billing | 14 |
| 17.0 | Street Vacations and Reservation of Easements for Metropolitan | 14 |
| 18.0 | Metropolitan Land Use Guidelines..... | 14 |
| 19.0 | Compliance with Environmental Laws and Regulations..... | 15 |
| 20.0 | Paramount Rights / Metropolitan's Rights within Existing Rights-of-Way | 17 |
| 21.0 | Disclaimer and Information Accuracy | 17 |

Table of Contents

Table 1: General Guidelines for Pipeline Separation between Metropolitan’s Pipeline¹ and Sanitary Sewer² or Hazardous Fluid Pipeline³18

Table 2: General Guidelines for Pipeline “Separation between Metropolitan’s Pipeline¹ and Storm Drain and/or Recycled Water²19

Table 3: General Guidelines for Pipeline “Separation¹ between Metropolitan’s Pipeline and Recycled Water^{2,4} Irrigationsm,20

Figure 1: AASHTO H-20 Loading21

Figure 2: Drawing SK-122

This page is intentionally blank.

1.0 GENERAL INFORMATION

Note: Underground Service Alert at 811 must be notified at least two working days before excavating in proximity to Metropolitan's facilities.

1.1 Introduction

These guidelines provide minimum design and construction requirements for any utilities, facilities, developments, and improvements, or any other projects or activities, proposed in or near Metropolitan Water District of Southern California (Metropolitan) facilities and rights-of-way. Additional conditions and stipulations may also be required depending on project and site specific conditions. Any adverse impacts to Metropolitan's conveyance system, as determined by Metropolitan, will need to be mitigated to its satisfaction.

All improvements and activities must be designed so as to allow for removal or relocation at builder or developer expense, as set forth in the paramount rights provisions of Section 20.0. Metropolitan shall not be responsible for repair or replacement of improvements, landscaping or vegetation in the event Metropolitan exercises its paramount rights powers.

1.2 Submittal and Review of Project Plans/Utilities and Maps

Metropolitan requires project plans/utilities be submitted for all proposed activities that may impact Metropolitan's facilities or rights-of-way. Project plans shall include copies of all pertinent utilities, sewer line, storm drain, street improvement, grading, site development, landscaping, irrigation and other plans, all tract and parcel maps, and all necessary state and federal environmental documentation. Metropolitan will review the project plans and provide written approval, as it pertains to Metropolitan's facilities and rights-of-way. Written approval from Metropolitan must be obtained, prior to the start of any activity or construction in the area of Metropolitan's facilities or rights-of-way. Once complete project plans and supporting documents are submitted to Metropolitan, it generally takes 30 days to review and to prepare a detailed written response. Complex engineering plans that have the potential for significant impacts on Metropolitan's facilities or rights-of-way may require a longer review time.

Project plans, maps, or any other information should be submitted to Metropolitan's Substructures Team at the following mailing address:

Attn: Substructures Team
The Metropolitan Water District of Southern California
700 North Alameda St.
Los Angeles, CA 90012

General Mailing Address: P.O. Box 54153
Los Angeles, CA 90054-0153

Email: EngineeringSubstructures@mwdh2o.com

For additional information, or to request prints of detailed drawings for Metropolitan's facilities and rights-of-way, please contact Metropolitan's Substructures Team at 213-217-7663 or EngineeringSubstructures@mwdh2o.com.

1.3 Identification of Metropolitan's Facilities and Rights-of-Way

Metropolitan's facilities and rights-of-way must be fully shown and identified as Metropolitan's, with official recording data, on the following:

- A. All applicable plans
- B. All applicable tract and parcel maps

Metropolitan's rights-of-ways and existing survey monuments must be tied dimensionally to the tract or parcel boundaries. Metropolitan's Records of Survey must be referenced on the tract and parcel maps with the appropriate Book and Page.

2.0 General Requirements

2.1 Vehicular Access

Metropolitan must have vehicular access along its rights-of-way at all times for routine inspection, patrolling, operations, and maintenance of its facilities and construction activities. All proposed improvements and activities must be designed so as to accommodate such vehicular access.

2.2 Fences

Fences installed across Metropolitan's rights-of-way must include a 16-foot-wide gate to accommodate vehicular access by Metropolitan. Additionally, gates may be required at other specified locations to prevent unauthorized entry into Metropolitan's rights-of-way.

All gates must accommodate a Metropolitan lock or Knox-Box with override switch to allow Metropolitan unrestricted access. There should be a minimum 20-foot setback for gates from the street at the driveway approach. The setback is necessary to allow Metropolitan vehicles to safely pull off the road prior to opening the gate.

2.3 Driveways and Ramps

Construction of 16-foot-wide commercial-type driveway approaches is required on both sides of all streets that cross Metropolitan's rights-of-way. Access ramps, if necessary, must be a minimum of 16 feet wide.

There should be a minimum 20-foot setback for gates from the street at the driveway approach. Grades of ramps and access roads must not exceed 10 percent; if the slope of an access ramp or road must exceed 10 percent due to topography, then the ramp or road must be paved.

2.4 Walks, Bike Paths, and Trails

All walkways, bike paths, and trails along Metropolitan's rights-of-way must be a minimum 12-foot wide and have a 50-foot or greater radius on all horizontal curves if also used as Metropolitan's access roads. Metropolitan's access routes, including all walks and drainage facilities crossing the access routes, must be constructed to American Association of State Highway and Transportation Officials (AASHTO) H-20 loading standards (see Figure 1). Additional requirements will be placed on equestrian trails to protect the water quality of Metropolitan's pipelines and facilities.

2.5 Clear Zones

A 20-foot-wide clear zone is required to be maintained around Metropolitan's manholes and other above-ground facilities to accommodate vehicular access and maintenance. The clear zone should slope away from Metropolitan's facilities on a grade not to exceed 2 percent.

2.6 Slopes

Cut or fill slopes proposed within Metropolitan's rights-of-way must not exceed 10 percent. The proposed grade must not worsen the existing condition. This restriction is required to facilitate Metropolitan use of construction and maintenance equipment and allow uninhibited access to above-ground and below-ground facilities.

2.7 Structures

Construction of structures of any type is not allowed within the limits of Metropolitan's rights-of-way to avoid interference with the operation and maintenance of Metropolitan's facilities and possible construction of future facilities.

Footings and roof eaves of any proposed buildings adjacent to Metropolitan's rights-of-way must meet the following criteria:

- A. Footings and roof eaves must not encroach onto Metropolitan's rights-of-way.
- B. Footings must not impose any additional loading on Metropolitan's facilities.
- C. Roof eaves must not overhang onto Metropolitan's rights-of-way.

Detailed plans of footings and roof eaves adjacent to Metropolitan's rights-of-way must be submitted for Metropolitan's review and written approval, as pertains to Metropolitan's facilities.

2.8 Protection of Metropolitan Facilities

Metropolitan facilities within its rights-of-way, including pipelines, structures, manholes, survey monuments, etc., must be protected from damage by the project proponent or property owner, at no expense to Metropolitan. The exact location, description and method of protection must be shown on the project plans.

2.9 Potholing of Metropolitan Pipelines

Metropolitan's pipelines must be potholed in advance, if the vertical clearance between a proposed utility and Metropolitan's pipeline is indicated to be 4 feet or less. A Metropolitan representative must be present during the potholing operation and will assist in locating the pipeline. Notice is required, a minimum of three working days, prior to any potholing activity.

2.10 Jacked Casings or Tunnels

A. General Requirements

Utility crossings installed by jacking, or in a jacked casing or tunnel under/over a Metropolitan pipeline, must have at least 3 feet of vertical clearance between the outside diameter of the pipelines and the jacked pipe, casing, or tunnel. The actual

cover over Metropolitan's pipeline shall be determined by potholing, under Metropolitan's supervision.

Utilities installed in a jacked casing or tunnel must have the annular space between the utility and the jacked casing or tunnel filled with grout. Provisions must be made for grouting any voids around the exterior of the jacked pipe, casing, or tunnel.

B. Jacking or Tunneling Procedures

Detailed jacking, tunneling, or directional boring procedures must be submitted to Metropolitan for review and approval. The procedures must cover all aspects of operation, including, but not limited to, dewatering, ground control, alignment control, and grouting pressure. The submittal must also include procedures to be used to control sloughing, running, or wet ground, if encountered. A minimum 10-foot clearance must be maintained between the face of the tunneling or receiving pits and outside edges of Metropolitan's facility.

C. Shoring

Detailed drawings of shoring for jacking or receiving pits must be submitted to Metropolitan for review and written-approval. (See Section 10 for shoring requirements).

D. Temporary Support

Temporary support of Metropolitan's pipelines may be required when a utility crosses under a Metropolitan pipeline and is installed by means of an open trench. Plans for temporary support must be reviewed and approved in writing by Metropolitan. (See Section 11, Supports of Metropolitan Facilities).

3.0 Landscaping

3.1 Plans

All landscape plans must show the location and limits of Metropolitan's right-of-way and the location and size of Metropolitan's pipeline and related facilities therein. All landscaping and vegetation shall be subject to removal without notice, as may be required by Metropolitan for ongoing maintenance, access, repair, and construction activities. Metropolitan will not be financially responsible for the removal of any landscaping and vegetation.

3.2 Drought-Tolerant Native and California Friendly Plants

Metropolitan recommends use of drought-tolerant native and California Friendly® plants (excluding sensitive plants) on proposed projects. For more information regarding California Friendly® plants refer to www.bewaterwise.com.

3.3 Trees

Trees are generally prohibited within Metropolitan's rights-of-way as they restrict Metropolitan's ability to operate, maintain and/or install new pipeline(s) located within these rights-of-way. Metropolitan will not be financially responsible for the removal and replacement of any existing trees should they interfere with access and any current or future Metropolitan project located within the right-of-way.

3.4 Other Vegetation

Shrubs, bushes, vines, and groundcover are generally allowed within Metropolitan's rights-of-way. Larger shrubs are not allowed on Metropolitan fee properties; however, they may be allowed within its easements if planted no closer than 15 feet from the outside edges of existing or future Metropolitan facilities. Only groundcover is allowed to be planted directly over Metropolitan pipeline, turf blocks or similar is recommended to accommodate our utility vehicle access. Metropolitan will not be financially responsible for the removal and replacement of the vegetation should it interfere with access and any current or future Metropolitan project.

3.5 Irrigation

Irrigation systems are acceptable within Metropolitan's rights-of-way, provided valves and controllers are located near the edges of the right-of-way and do not interfere with Metropolitan vehicular access. A shutoff valve should also be located along the edge of the right-of-way that will allow the shutdown of the system within the right-of-way should Metropolitan need to do any excavation. No pooling or saturation of water above Metropolitan's pipeline and right-of-way is allowed. Additional restrictions apply to non-potable water such as Recycled Water and are covered on Table 3 of Page 20.

3.6 Metropolitan Vehicular Access

Landscape plans must show Metropolitan vehicular access to Metropolitan's facilities and rights-of-way and must be maintained by the property owner or manager or homeowners association at all times. Walkways, bike paths, and trails within Metropolitan's rights-of-way may be used as Metropolitan access routes. (See Section 2.4, Walks, Bike Paths, and Trails).

4.0 General Utilities

Note: For non-potable piping like sewer, hazardous fluid, storm drain, disinfected tertiary recycled water and recycled water irrigation see Table 1 through Table 3.

4.1 Utility Structures

Permanent utility structures (e.g., manholes, power poles, pull boxes, electrical vaults, etc.) are not allowed within Metropolitan's rights-of-way. Metropolitan requests that all permanent utility structures within public streets be placed as far from its pipelines and facilities as practical, but not closer than 5 feet from the outside edges of Metropolitan facilities.

Note: Non-potable utility pipelines are an exception to the 5-foot minimum clearance. Non-potable utility pipelines should have 10 feet of separation.

4.2 Utility Crossings

Metropolitan requests a minimum of 1 foot of vertical clearance between Metropolitan's pipeline and any utility crossing the pipeline. Utility lines crossing Metropolitan's pipelines must be as perpendicular to the pipeline as possible. Cross-section drawings, showing proposed locations and elevations of utility lines and locations of Metropolitan's pipelines and limits of rights-of-way, must be submitted with utility plans, for all

crossings. Metropolitan's pipeline must be potholed under Metropolitan's supervision at the crossings (See Section 2.9).

4.3 Longitudinal Utilities

Installation of longitudinal utilities is generally not allowed along Metropolitan's rights-of-way. Within public streets, Metropolitan requests that all utilities parallel to Metropolitan's pipelines and appurtenant structures (facilities) be located as far from the facilities as possible, with a minimum clearance of 5 feet from the outside edges of the pipeline.

Note: Non-potable utility pipelines are an exception to the 5-foot minimum clearance. Non-potable utility pipelines should have 10 feet of separation (for more information See Table 1 on Page 18).

4.4 Underground Electrical Lines

Underground electrical conduits (110 volts or greater) which cross a Metropolitan's pipeline must have a minimum of 1 foot of vertical clearance between Metropolitan's pipeline and the electrical lines. Longitudinal electrical lines, including pull boxes and vaults, in public streets should have a minimum separation of 5 feet from the edge of a Metropolitan pipeline or structures.

4.5 Fiber Optic Lines

Fiber optic lines installed by directional boring require a minimum of 3 feet of vertical clearance when boring is over Metropolitan's pipelines and a minimum of 5 feet of vertical clearance when boring is under Metropolitan's pipelines. Longitudinal fiber optic lines, including pull boxes, in public streets should have a minimum separation of 5 feet from the edge of a Metropolitan pipelines or structures. Potholing must be performed, under Metropolitan's supervision, to verify the vertical clearances are maintained.

4.6 Overhead Electrical and Telephone Lines

Overhead electrical and telephone lines, where they cross Metropolitan's rights-of-way, must have a minimum 35 feet of clearance, as measured from the ground to the lowest point of the overhead line. Overhead electrical lines poles must be located at least 30 feet laterally from the edges of Metropolitan's facilities or outside Metropolitan's right-of-way, whichever is greater.

Longitudinal overhead electrical and or telephone lines in public streets should have a minimum separation of 10 feet from the edge of a Metropolitan pipelines or structures where possible.

4.7 Sewage Disposal Systems

Sewage disposal systems, including leach lines and septic tanks, must be a minimum of 100 feet from the outside limits of Metropolitan's rights-of-way or the edge of its facilities, whichever is greater. If soil conditions are poor, or other adverse site-specific conditions exist, a minimum distance of 150 feet is required. They must also comply with local and state health code requirements as they relate to sewage disposal systems in proximity to major drinking water supply pipelines.

4.8 Underground Tanks

Underground tanks containing hazardous materials must be a minimum of 100 feet from the outside limits of Metropolitan's rights-of-way or edge of its facilities, whichever is greater. In addition, groundwater flow should be considered with the placement of underground tanks down-gradient of Metropolitan's facilities.

5.0 Specific Utilities: Non-Potable Utility Pipelines

In addition to Metropolitan's general requirements, installation of non-potable utility pipelines (e.g., storm drains, sewers, and hazardous fluids pipelines) in Metropolitan's rights-of-way and public street rights-of-way must also conform to the State Water Resources Control Board's Division of Drinking Water (DDW) regulation (Waterworks Standards) and guidance for separation of water mains and non-potable pipelines and to applicable local county health code requirements. Written approval is required from DDW for the implementation of alternatives to the Waterworks Standards and, effective December 14, 2017, requests for alternatives to the Waterworks Standards must include information consistent with: DDW's [Waterworks Standards Main Separation Alternative Request Checklist](#).

In addition to the following general guidelines, further review of the proposed project must be evaluated by Metropolitan and requirements may vary based on site specific conditions.

- A. Sanitary Sewer and Hazardous Fluids (General Guideline See Table 1 on Page 18)
- B. Storm Drain and Recycled Water (General Guideline See Table 2 on Page 19)
- C. Irrigation with Recycled Water (General Guideline See Table 3 on Page 20)
- D. Metropolitan generally does not allow Irrigation with recycled water to be applied directly above its treated water pipelines
- E. Metropolitan requests copies of project correspondence with regulating agencies (e.g., Regional Water Quality Control Board, DDW); regarding the application of recycled water for all projects located on Metropolitan's rights-of-way

6.0 Cathodic Protection/Electrolysis Test Stations

6.1 Metropolitan Cathodic Protection

Metropolitan's existing cathodic protection facilities in the vicinity of any proposed work must be identified prior to any grading or excavation. The exact location, description, and type of protection must be shown on all project plans. Please contact Metropolitan for the location of its cathodic protection stations.

6.2 Review of Cathodic Protection Systems

Metropolitan must review any proposed installation of impressed-current cathodic protection systems on pipelines crossing or paralleling Metropolitan's pipelines to determine any potential conflicts with Metropolitan's existing cathodic protection system.

7.0 Drainage

7.1 Drainage Changes Affecting Metropolitan Rights-of-Way

Changes to existing drainage that could affect Metropolitan's rights-of-way require Metropolitan's approval. The project proponent must provide acceptable solutions to ensure Metropolitan's rights-of-way are not negatively affected by changes in the drainage conditions. Plans showing the changes, with a copy of a supporting hydrology report and hydraulic calculations, must be submitted to Metropolitan for review and approval. Long term maintenance of any proposed drainage facilities must be the responsibility of the project proponent, City, County, homeowner's association, etc., with a clear understanding of where this responsibility lies. If drainage must be discharged across Metropolitan's rights-of-way, it must be carried across by closed conduit or lined open channel and must be shown on the plans.

7.2 Metropolitan's Blowoff and Pumpwell Structures

Any changes to the existing local watercourse systems will need to be designed to accommodate Metropolitan's blowoff and pumpwell structures, which periodically convey discharged water from Metropolitan's blowoff and pumping well structures during pipeline dewatering. The project proponents' plans should include details of how these discharges are accommodated within the proposed development and must be submitted to Metropolitan for review and approval. Any blowoff discharge lines impacted must be modified accordingly at the expense of the project proponent.

8.0 Grading and Settlement

8.1 Changes in Cover over Metropolitan Pipelines

The existing cover over Metropolitan's pipelines must be maintained unless Metropolitan determines that proposed changes in grade and cover do not pose a hazard to the integrity of the pipeline or an impediment to its maintenance capability. Load and settlement or rebound due to change in cover over a Metropolitan pipeline or ground in the area of Metropolitan's rights-of-way will be factors considered by Metropolitan during project review.

In general, the minimum cover over a Metropolitan pipeline is 4 feet and the maximum cover varies per different pipeline. Any changes to the existing grade may require that Metropolitan's pipeline be potholed under Metropolitan's supervision to verify the existing cover.

8.2 Settlement

Any changes to the existing topography in the area of Metropolitan's pipeline or right-of-way that result in significant settlement or lateral displacement of Metropolitan's pipelines are not acceptable. Metropolitan may require submittal of a soils report showing the predicted settlement of the pipeline at 10-foot intervals for review. The data must be carried past the point of zero change in each direction and the actual size and varying depth of the fill must be considered when determining the settlement. Possible settlement due to soil collapse, rebound and lateral displacement must also be included.

In general, the typical maximum allowed deflection for Metropolitan's pipelines must not exceed a deflection of 1/4-inch for every 100 feet of pipe length. Metropolitan may require additional information per its Geotechnical Guidelines. Please contact Metropolitan's Substructures Team for a copy of the Geotechnical Guidelines.

9.0 Construction Equipment

9.1 Review of Proposed Equipment

Use of equipment across or adjacent to Metropolitan's facilities is subject to prior review and written approval by Metropolitan. Excavation, backfill, and other work in the vicinity of Metropolitan's facilities must be performed only by methods and with equipment approved by Metropolitan. A list of all equipment to be used must be submitted to Metropolitan a minimum of 30 days before the start of work.

- A. For equipment operating within paved public roadways, equipment that imposes loads not greater than that of an AASHTO H-20 vehicle (see Figure 1 on Page 21) may operate across or adjacent to Metropolitan's pipelines provided the equipment operates in non-vibratory mode and the road remains continuously paved.
- B. For equipment operating within unpaved public roadways, when the total cover over Metropolitan's pipeline is 10 feet or greater, equipment imposing loads no greater than those imposed by an AASHTO H-20 vehicle may operate over or adjacent to the pipeline provided the equipment is operated in non-vibratory mode. For crossings, vehicle path shall be maintained in a smooth condition, with no breaks in grade for 3 vehicle lengths on each side of the pipeline.

9.2 Equipment Restrictions

In general, no equipment may be used closer than 20 feet from all Metropolitan above-ground structures. The area around the structures should be flagged to prevent equipment encroaching into this zone.

9.3 Vibratory Compaction Equipment

Vibratory compaction equipment may not be used in vibratory mode within 20 feet of the edge of Metropolitan's pipelines.

9.4 Equipment Descriptions

The following information/specifications for each piece of equipment should be included on the list:

- A. A description of the equipment, including the type, manufacturer, model year, and model number. For example, wheel tractor-scraper, 1990 Caterpillar 627E.
- B. The empty and loaded total weight and the corresponding weight distribution. If equipment will be used empty only, it should be clearly stated.
- C. The wheel base (for each axle), tread width (for each axle), and tire footprint (width and length) or the track ground contact (width and length), and track gauge (center to center of track).

10.0 Excavations Close to Metropolitan Facilities

10.1 Shoring Design Submittal

Excavation that impacts Metropolitan's facilities requires that the contractor submit an engineered shoring design to Metropolitan for review and acceptance a minimum of 30 days before the scheduled start of excavation. Excavation may not begin until the shoring design is accepted in writing by Metropolitan.

Shoring design submittals must include all required trenches, pits, and tunnel or jacking operations and related calculations. Before starting the shoring design, the design engineer should consult with Metropolitan regarding Metropolitan's requirements, particularly as to any special procedures that may be required.

10.2 Shoring Design Requirements

Shoring design submittals must be stamped and signed by a California registered civil or structural engineer. The following requirements apply:

- A. The submitted shoring must provide appropriate support for soil adjacent to and under Metropolitan's facilities.
- B. Shoring submittals must include detailed procedures for the installation and removal of the shoring.
- C. Design calculations must follow the Title 8, Chapter 4, Article 6 of the California Code of Regulations (CCR) guidelines. Accepted methods of analysis must be used.
- D. Loads must be in accordance with the CCR guidelines or a soils report by a geotechnical consultant.
- E. All members must be secured to prevent sliding, falling, or kickouts.

Metropolitan's pipelines must be located by potholing under Metropolitan's supervision before the beginning construction. Use of driven piles within 20 feet of the centerline of Metropolitan's pipeline is not allowed. Piles installed in drilled holes must have a minimum 2-foot clearance between Metropolitan's pipeline and the edge of the drilled hole, and a minimum of 1-foot clearance between any part of the shoring and Metropolitan's pipeline.

11.0 Support of Metropolitan Facilities

11.1 Support Design Submittal

If temporary support of a Metropolitan facility is required, the contractor shall submit a support design plan to Metropolitan for review and approval a minimum of 30 days before the scheduled start of work. Work may not begin until the support design is approved in writing by Metropolitan. Before starting design, the design engineer should consult with Metropolitan regarding Metropolitan's requirements.

11.2 Support Design Requirements

Support design submittals must be prepared, stamped, and signed by a California registered civil or structural engineer. The following requirements apply:

- A. Support drawings must include detailed procedures for the installation and removal of the support system.
- B. Design calculations must follow accepted practices, and accepted methods of analysis must be used.
- C. Support designs must show uniform support of Metropolitan's facilities with minimal deflection.
- D. The total weight of the facility must be transferred to the support system before supporting soil is fully excavated.
- E. All members must be secured to prevent sliding, falling, or kickouts.

12.0 Backfill

12.1 Metropolitan Pipeline Not Supported

In areas where a portion of Metropolitan pipeline is not supported during construction, the backfill under and to an elevation of 6 inches above the top of the pipeline must be one-sack minimum cement sand slurry. To prevent adhesion of the slurry to Metropolitan's pipeline, a minimum 6-mil-thick layer of polyethylene sheeting or similar approved sheeting must be placed between the concrete support and the pipeline.

12.2 Metropolitan Pipeline Partially Exposed

In areas where a Metropolitan pipeline is partially exposed during construction, the backfill must be a minimum of 6 inches above the top of the pipeline with sand compacted to minimum 90 percent compaction.

12.3 Metropolitan Cut and Cover Conduit on Colorado River Aqueduct (CRA)

In areas where a Metropolitan cut and cover conduit is exposed, the following guidelines apply:

- A. No vehicle or equipment shall operate over or cross the conduit when the cover is less than 3 feet.
- B. Track-type dozer with a gross vehicle weight of 12,000 lbs or less may be used over the conduit when the cover is a minimum of 3 feet.
- C. Wheeled vehicles with a gross vehicle weight of 8,000 lbs or less may operate over the conduit when the cover is a minimum of 4 feet.
- D. Tracked dozer or wheeled vehicle should be used to push material over the conduit from the side.
- E. Tracked dozer or wheeled vehicle should gradually increase cover on one side of the conduit and then cross the conduit and increase cover on the other side of the conduit. The cover should be increased on one side of the conduit until a maximum of 2 feet of fill has been placed. The cover over the conduit is not allowed to be more than 2 feet higher on one side of the conduit than on the other side.
- F. The cover should be gradually increased over the conduit until the grade elevations have been restored.

13.0 Piles

13.1 Impacts on Metropolitan Pipelines

Pile support for structures could impose lateral, vertical and seismic loads on Metropolitan's pipelines. Since the installation of piles could also cause settlement of Metropolitan pipelines, a settlement and/or lateral deformation study may be required for pile installations within 50 feet of Metropolitan's pipelines. Metropolitan may require additional information per its Geo-technical Guidelines for pile installation. Please contact Metropolitan's Substructures Team for a copy of the Geotechnical Guidelines.

13.2 Permanent Cast-in-place Piles

Permanent cast-in-place piles must be constructed so that down drag forces of the pile do not act on Metropolitan's pipeline. The pile must be designed so that down drag forces are not developed from the ground surface to springline of Metropolitan's pipeline.

Permanent cast-in-place piles shall not be placed closer than 5 feet from the edge of Metropolitan's pipeline. Metropolitan may require additional information per its Geo-technical Guidelines for pile installation. Please contact Metropolitan's Substructures Team for a copy of the Geotechnical Guidelines.

14.0 Protective Slabs for Road Crossings Over Metropolitan Pipelines

Protective slabs must be permanent cast-in-place concrete protective slabs configured in accordance with Drawing SK-1 (See Figure 2 on Page 22).

The moments and shear for the protective slab may be derived from the American Association of State Highway and Transportation Officials (AASHTO). The following requirements apply:

- A. The concrete must be designed to meet the requirements of AASHTO
- B. Load and impact factors must be in accordance with AASHTO. Accepted methods of analysis must be used.
- C. The protective slab design must be stamped and signed by a California registered civil or structural engineer and submitted to Metropolitan with supporting calculations for review and approval.

Existing protective slabs that need to be lengthened can be lengthened without modification, provided the cover and other loading have not been increased.

15.0 Blasting

At least 90 days prior to the start of any drilling for rock excavation blasting, or any blasting in the vicinity of Metropolitan's facilities, a site-specific blasting plan must be submitted to Metropolitan for review and approval. The plan must consist of, but not be limited to, hole diameters, timing sequences, explosive weights, peak particle velocities (PPV) at Metropolitan pipelines/structures, and their distances to blast locations. The PPV must be estimated based on a site-specific power law equation. The power law equation provides the peak particle velocity versus the scaled distance and must be calibrated based on measured values at the site.

16.0 Metropolitan Plan Review Costs, Construction Costs and Billing

16.1 Plan Review Costs

Metropolitan plan reviews requiring 8 labor hours or less are generally performed at no cost to the project proponent. Metropolitan plan reviews requiring more than 8 labor hours must be paid by the project proponent, unless the project proponent has superior rights at the project area. The plan review will include a written response detailing Metropolitan's comments, requirements, and/or approval.

A deposit of funds in the amount of the estimated cost and a signed letter agreement will be required from the project proponent before Metropolitan begins or continues a detailed engineering plan review that exceeds 8 labor hours.

16.2 Cost of Modification of Facilities Performed by Metropolitan

Cost of modification work conducted by Metropolitan will be borne by the project proponent, when Metropolitan has paramount/prior rights at the subject location.

Metropolitan will transmit a cost estimate for the modification work to be performed (when it has paramount/prior rights) and will require that a deposit, in the amount of the estimate, be received before the work will be performed.

16.3 Final Billing

Final billing will be based on the actual costs incurred, including engineering plan review, inspection, materials, construction, and administrative overhead charges calculated in accordance with Metropolitan's standard accounting practices. If the total cost is less than the deposit, a refund will be made; however, if the cost exceeds the deposit, an invoice for the additional amount will be forwarded for payment.

17.0 Street Vacations and Reservation of Easements for Metropolitan

A reservation of an easement is required when all or a portion of a public street where Metropolitan facilities are located is to be vacated. The easement must be equal to the street width being vacated or a minimum 40 feet. The reservation must identify Metropolitan as a "public entity" and not a "public utility," prior to recordation of the vacation or tract map. The reservation of an easement must be submitted to Metropolitan for review prior to final approval.

18.0 Metropolitan Land Use Guidelines

If you are interested in obtaining permission to use Metropolitan land (temporary or long term), a Land Use Form must be completed and submitted to Metropolitan for review and consideration. A nonrefundable processing fee is required to cover Metropolitan's costs for reviewing your request. Land Use Request Forms can be found at:

http://mwdh2o.com/PDF_Doing_Your_Business/4.7.1_Land_Use_Request_form_revised.pdf

The request should be emailed to RealEstateServices@mwdh2o.com, or contact the Real Property Development and Management (RPDM) Group at (213) 217-7750.

After the initial application form has been submitted, Metropolitan may require the following in order to process your request:

- A. A map indicating the location(s) where access is needed, and the location & size (height, width and depth) of any invasive subsurface activity (boreholes, trenches, etc.).
- B. The California Environmental Quality Act (CEQA) document(s) or studies that have been prepared for the project (e.g., initial study, notice of exemption, Environmental Impact Report (EIR), Mitigated Negative Declaration (MND), etc.).
- C. A copy of an ACORD insurance certification naming Metropolitan as an additional insured, or a current copy of a statement of self-insurance.
- D. Confirmation of the legal name of the person(s) or entity(ies) that are to be named as the permittee(s) in the entry permit.
- E. Confirmation of the purpose of the land use.
- F. The name of the person(s) with the authority to sign the documents and any specific signature title block requirements for that person or any other persons required to sign the document (i.e., legal counsel, Board Secretary/Clerk, etc.).
- G. A description of any vehicles that will have access to the property. The exact make or model information is not necessary; however, the general vehicle type, expected maximum dimensions (height, length, width), and a specific maximum weight must be provided.

Land use applications and proposed use of the property must be compatible with Metropolitan's present and/or future use of the property. Any preliminary review of your request by Metropolitan shall not be construed as a promise to grant any property rights for the use of Metropolitan's property.

19.0 Compliance with Environmental Laws and Regulations

As a public agency, Metropolitan is required to comply with all applicable environmental laws and regulations related to the activities it carries out or approves. Consequently, project plans, maps, and other information must be reviewed to determine Metropolitan's obligations pursuant to state and federal environmental laws and regulations, including, but not limited to:

- A. California Environmental Quality Act (CEQA) (Public Resources Code 21000-21177) and the State CEQA Guidelines (California Code of Regulations, Title 14, Division 6, Chapter 3, Sections 1500-15387)
- B. Federal Endangered Species Act (ESA) of 1973, 16 U.S.C. §§ 1531, et seq.
- C. California Fish and Game Code Sections 2050-2069 (California ESA)
- D. California Fish and Game Code Section 1602
- E. California Fish and Game Code Sections 3511, 4700, 5050 and 5515 (California fully protected species)
- F. Federal Migratory Bird Treaty Act (MBTA), 16 U.S.C. §§ 703-712
- G. Federal Clean Water Act (including but not limited to Sections 404 and 401) 33 U.S.C. §§ 1342, 1344)

- H. Porter Cologne Water Quality Control Act of 1969, California Water Code §§ 13000-14076.
- I. Title 22, California Code of Regulations, Chapter 16 (California Waterworks Standards), Section 64572 (Water Main Separation)

Metropolitan may require the project applicant to pay for any environmental review, compliance and/or mitigation costs incurred to satisfy such legal obligations.

20.0 Paramount Rights / Metropolitan's Rights within Existing Rights-of-Way

Facilities constructed within Metropolitan's rights-of-way shall be subject to the paramount right of Metropolitan to use its rights-of-way for the purpose for which they were acquired. If at any time Metropolitan or its assigns should, in the exercise of their rights, find it necessary to remove or relocate any facilities from its rights-of-way, such removal and replacement or relocation shall be at the expense of the owner of the facility.

21.0 Disclaimer and Information Accuracy

Metropolitan assumes no responsibility for the accuracy of the substructure information herein provided. The user assumes responsibility for verifying substructure locations before excavating and assumes all liability for damage to Metropolitan's facilities as a result of such excavation. Additionally, the user is cautioned to conduct surveys and other field investigations as you may deem prudent, to assure that your project plans are correct. The relevant representative from Metropolitan must be called at least two working days, before any work activity in proximity to Metropolitan's facilities.

It generally takes 30 days to review project plans and provide written responses. Metropolitan reserves the right to modify requirements based on case-specific issues and regulatory developments.

Table 1: General Guidelines for Pipeline Separation between Metropolitan’s Pipeline¹ and Sanitary Sewer² or Hazardous Fluid Pipeline³

| | |
|----------------------------------|--|
| <p><u>Pipeline Crossings</u></p> | <p>Metropolitan requires that sanitary sewer and hazardous fluid pipelines that cross Metropolitan’s pipelines have special pipe construction (no joints) and secondary containment⁴. This is required for the full width of Metropolitan’s rights-of-way or within 10 feet tangent to the outer edges of Metropolitan’s pipeline within public streets. Additionally, sanitary sewer and hazardous fluid pipelines crossing Metropolitan’s pipelines must be perpendicular and maintain a minimum 1-foot vertical clearance between the top and the bottom of Metropolitan’s pipeline and the pipe casing.</p> <p>These requirements apply to all sanitary sewer crossings regardless if the sanitary sewer main is located below or above Metropolitan’s pipeline.</p> |
| <p><u>Parallel Pipeline</u></p> | <p>Metropolitan generally does not permit the installation of longitudinal pipelines along its rights-of-way. Within public streets, Metropolitan requires that all parallel sanitary sewer, hazardous fluid pipelines and/or non-potable utilities be located a minimum of 10 feet from the outside edges of Metropolitan’s pipelines. When 10-foot horizontal separation criteria cannot be met, longitudinal pipelines require special pipe construction (no joints) and secondary containment⁴.</p> |
| <p><u>Sewer Manhole</u></p> | <p>Sanitary sewer manholes are not allowed within Metropolitan’s rights-of-way. Within public streets, Metropolitan requests manholes parallel to its pipeline be located a minimum of 10 feet from the outside edges of its pipelines. When 10 foot horizontal separation criteria cannot be met, the structure must have secondary containment⁵.</p> |

Notes:

¹ Separation distances are measured from the outer edges of each pipe.

² Sanitary sewer requirements apply to all recycled water treated to less than disinfected tertiary recycled water (disinfected secondary recycled water or less). Recycled water definitions are included in Title 22, California Code of Regulations, Chapter 3 (Water Recycling Criteria), Section 60301.

³ Hazardous fluids include e.g., oil, fuels, chemicals, industrial wastes, wastewater sludge, etc.

⁴ Secondary Containment for Pipeline - Secondary containment consists of a continuous pipeline sleeve (no joints). Examples acceptable to Metropolitan include welded steel pipe with grout in annular space and cathodic protection (unless coated with non-conductive material) and High Density Polyethylene (HDPE) pipe with fusion-welded joints.

⁵ Secondary Containment for Structures – Secondary containment consists of external HDPE liner or other approved method.

Table 2: General Guidelines for Pipeline Separation between Metropolitan’s Pipeline¹ and Storm Drain and/or Disinfected Tertiary Recycled Water²

| | |
|--|--|
| <p><u>Pipeline Crossings</u></p> | <p>Metropolitan requires crossing pipelines to be special pipe construction (no joints) or have secondary containment³ within 10-feet tangent to the outer edges of Metropolitan’s pipeline. Additionally, pipelines crossing Metropolitan’s pipelines must be perpendicular and maintain a minimum 1-foot vertical clearance.</p> |
| <p><u>Parallel Pipeline</u></p> | <p>Metropolitan generally does not permit the installation of longitudinal pipelines along its rights-of-way. Within public streets, Metropolitan requests that all parallel pipelines be located a minimum of 10 feet from the outside edges of Metropolitan’s pipelines. When 10-foot horizontal separation criteria cannot be met, special pipe construction (no joints) or secondary containment³ are required.</p> |
| <p><u>Storm Drain Manhole</u></p> | <p>Permanent utility structures (e.g., manhole, catch basin, inlets) are not allowed within Metropolitan’s rights-of-way. Within public streets, Metropolitan requests all structures parallel to its pipeline be located a minimum of 10 feet from the outside edges of its pipelines. When 10 foot horizontal separation criteria cannot be met, the structure must have secondary containment⁴.</p> |

Notes:

¹ Separation distances are measured from the outer edges of each pipe.

² Disinfected tertiary recycled water as defined in Title 22, California Code of Regulations, Chapter 3 (Water Recycling Criteria), Section 60301.

³ Secondary Containment for Pipeline - Secondary containment consists of a continuous pipeline sleeve (no joints). Examples acceptable to Metropolitan include welded steel pipe with grout in annular space and cathodic protection (unless coated with non-conductive material) and High Density Polyethylene (HDPE) pipe with fusion-welded joints.

⁴ Secondary Containment for Structures – Secondary containment consists of external HDPE liner or other approved method.

Table 3: General Guidelines for Pipeline Separation¹ between Metropolitan’s Pipeline and Recycled Water^{2,4} Irrigations

| | |
|---|---|
| <p>Pressurized recycled irrigation mainlines</p> | <ul style="list-style-type: none"> • Crossings - must be perpendicular and maintain a minimum 1-foot vertical clearance. Crossing pressurized recycled irrigation mainlines must be special pipe construction (no joints) or have secondary containment³ within 10-feet tangent to the outer edges of Metropolitan’s pipeline. • Longitudinal - must maintain a minimum 10-foot horizontal separation and route along the perimeter of Metropolitan’s rights-of-way where possible. |
| <p>Intermittently Energized Recycled Water Irrigation System Components</p> | <ul style="list-style-type: none"> • Crossings - must be perpendicular and maintain a minimum 1-foot vertical clearance. Crossing irrigation laterals within 5-feet tangent to the outer edges of Metropolitan’s pipeline must be special pipe construction (no joints) or have secondary containment³. • Longitudinal – must maintain a minimum 5-foot horizontal separation between all intermittently energized recycled water irrigation system components (e.g. irrigation lateral lines, control valves, rotors) and the outer edges of Metropolitan’s pipeline. Longitudinal irrigation laterals within 5-feet tangent to the outer edges of Metropolitan’s pipeline must be special pipe construction (no joints) or have secondary containment³. |
| <p>Irrigation Structures</p> | <p>Irrigation structures such as meters, pumps, control valves, etc. must be located outside of Metropolitan’s rights-of-way.</p> |
| <p>Irrigation spray rotors near Metropolitan’s aboveground facilities</p> | <p>Irrigation spray rotors must be located a minimum of 20-foot from any Metropolitan above ground structures with the spray direction away from these structures. These rotors should be routinely maintained and adjusted as necessary to ensure no over-spray into 20-foot clear zones.</p> |
| <p>Irrigations near open canals and aqueducts</p> | <p>Irrigation with recycled water near open canals and aqueducts will require a setback distance to be determined based on site-specific conditions. Runoff of recycled water must be contained within an approved use area and not impact Metropolitan facilities. Appropriate setbacks must also be in place to prevent overspray of recycled water impacting Metropolitan’s facilities.</p> |

Notes:

¹ Separation distances are measured from the outer edges of each pipe.

² Requirements for recycled water irrigation apply to all levels of treatment of recycled water for non-potable uses. Recycled water definitions are included in Title 22, California Code of Regulations, Chapter 3 (Water Recycling Criteria), Section 60301.

³ Secondary Containment for Pipeline - Secondary containment consists of a continuous pipeline sleeve (no joints). Examples acceptable to Metropolitan include welded steel pipe with grout in annular space and cathodic protection (unless coated with non-conductive material) and High Density Polyethylene (HDPE) pipe with fusion-welded joints.

⁴ Irrigation with recycled water shall not be applied directly above Metropolitan’s treated water pipelines.

Figure 1: AASHTO H-20 Loading

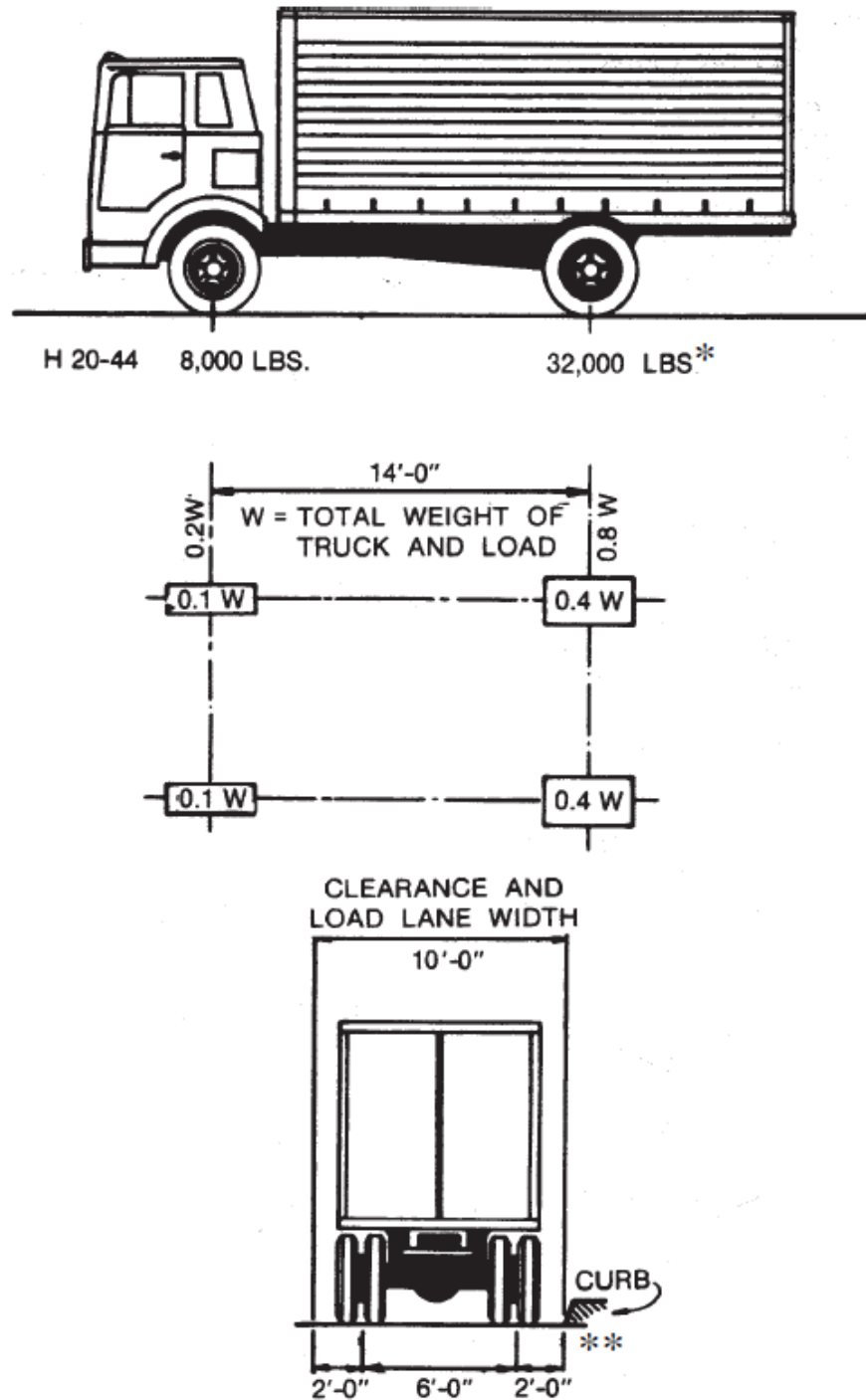

Note: The H loadings consist of a two-axle truck or the corresponding lane loadings as illustrated above. The H loadings are designated "H" followed by a number indicating the gross weight in tons of the standard truck.



December 21, 2022

Andrew Luna, Assistant Civil Engineer
City of La Habra
110 E. La Habra Blvd.
La Habra, Ca, 90631

**Re: C10282022C - Notice of Improvement Response Letter
FIRST UTILITY NOTICE FACILITY RESEARCH AND REQUEST FOR COMMENTS FOR CITY
OF LA HABRA
LA HABRA-MONTE VISTA STREET REHABILITATION PROJECT
CITY OF LA HABRA, CA**

Dear Andrew Luna,

Pursuant to your request dated October 27, 2022, pertaining to the above referenced project, please be advised that Crimson Midstream, LLC maintains pipelines within the vicinity of your proposed project. We are prepared to mark our facilities upon receiving 48-hour advanced Underground Service Alert (USA) notice.

Enclosed for your information are drawings that depict the general alignment of our pipelines. Upon completion of your final project drawings, please provide us a detailed set of your plans for our review to determine if there is a conflict with any of our existing facilities.

Crimson requires a representative to be on site during any construction activities within the vicinity of our facilities. Therefore, you or your contractors are hereby notified to contact, in addition to the above referenced USA notice, Crimson's designated representative, Shenan Lovrien office: 562-285-4107, between the hours of 6:30 A.M. and 5:00 P.M., Monday through Friday, a minimum of 48 hours in advance of commencing said construction activities.

Please be advised that any and all facilities identified as "Active", "Idle", or "Abandoned", unless otherwise clearly specified, remain the property of Crimson, and that all activities affecting these facilities must be approved and controlled by Crimson. Should it be determined that said facility potentially interferes with your project this office must be notified immediately, at which time Crimson personnel will review the issues to determine what actions will be necessary to identify and resolve any conflicts.

If you have questions or require additional information regarding this submittal, please contact Cordelia Cisneros at 562-285-4133.

Sincerely,

A handwritten signature in blue ink that reads 'Cordelia Cisneros'.

Cordelia Cisneros
Senior ROW Coordinator

CRIMSON PIPELINE L.P.

3760 Kilroy Airport Way, Suite 300
Long Beach, CA 90806

Construction Requirements in the Proximity of Crimson Pipelines

Crimson Pipeline L.P. (Crimson) is committed to the continued, safe operation of its pipeline. The listed construction requirements are designed to help ensure that the pipeline is protected from excavation damage, encroachment or other risks that could adversely impact the pipeline or prevent required inspection and maintenance activities.

1. Crimson requires two copies of any proposed plans for work within Crimson's right-of-way. Plans shall be provided 45 calendar days prior to commencement of work to the address listed above.
2. Above ground structures and improvements that interfere with the construction, maintenance or repair of the pipeline are prohibited within Crimson's right-of-way. Structures and improvements include, but are not limited to, buildings, fences and walls.
3. Landscaped areas are permitted within the right-of-way. Trees and large bushes that impede the visual inspection of the ground surface are not permitted within the right-of-way. Crimson shall review all plans that encroach the pipeline and the pipeline right of way prior to 4.
4. Federal law prohibits removing, damaging or defacing of pipelines, pipeline signs, or other appurtenances installed on the pipelines right of way.
5. Other utilities may be installed within the right-of-way with permission from Crimson. Such utilities must maintain a minimum of 5 feet parallel and 1-foot vertical clearances under Crimson's utilities unless approved in writing by Crimson prior to their installation. All clearances must conform to existing state and federal regulations.
6. A minimum of 3 feet, but not more than 6 feet of cover must be maintained over the pipeline at all times, unless otherwise approved by Crimson Pipeline in writing. The ground contour cannot be changed within the right-of-way without prior written permission by Crimson.
7. Proposed roads and utility crossings should cross Crimson's right-of-way as close to 90 degrees as possible. If, in Crimson's sole judgment, additional precautions are required to protect Crimson's pipeline, Crimson shall review and approve the construction plans in writing prior to the start of construction.
8. California State Law requires that parties notify Underground Service Alert at 1-800-227-2600, two full working days prior to digging.
9. All work on/or around the Crimson facility must comply with appropriate sections of Code of Federal Regulations Title 49, Part 195 - **TRANSPORTATION OF HAZARDOUS LIQUIDS BY PIPELINE.**
10. Crimson may choose to have an inspector on-site during any grading or excavation activities near the Crimson pipeline. Arrangements may be made for on-site inspection by contacting Crimson Utilities Coordinator at the address shown above.
11. Crimson requires that all excavation in the vicinity of the pipeline be done with hand tools in the presence of the Crimson's inspector consistent with California State Law requirements. Any damage to the pipeline shall be reported immediately. Crimson shall perform the necessary repair to insure the safety of the public safety. Crimson shall be reimbursed for all repair work necessary to continue with the safe, reliable operation of the pipeline.
12. In an emergency, including any damage or suspected damage to the Crimson pipeline, immediately notify Crimson at: 1-866-351-7473.
13. Any questions regarding construction activities in the vicinity of Crimson's pipeline shall be directed to:

UTILITIES COORDINATOR

Ph: (562) 285-4112 or (833) 876-4589

Fx: (562) 285-4141

Email: landdepartment@crimsonpl.com

Important Safety Information

for your community



CRIMSON PIPELINE LP

For more information, please contact: publicawareness@crimsonpl.com
Emergency number: 1-866-351-7473 • www.crimsonpl.com

Call before you dig. IT'S THE LAW!

One easy **FREE** phone call to 811 starts the process to get your underground pipelines and utility lines marked. When you call 811 from anywhere in the country, your call will be routed to your state One-Call Center. Once your underground lines have been marked for your project, you will know the approximate location of your pipelines and utility lines, and can dig safely. More information regarding 811 can be found at www.call811.com.



Crimson Pipeline maintains a Damage Prevention Program in accordance with state and federal guidelines. The purpose of this program is to prevent damage to our pipelines and facilities from excavation activities such as digging, trenching, blasting, boring, tunneling, backfilling, or by any other digging activity

How would you know where a pipeline is?

Most pipelines are underground, where they are more protected from the elements and minimize interference with surface uses. Even so, pipeline rights-of-way are clearly identified by pipeline markers along pipeline routes that identify the approximate—NOT EXACT—location of the pipeline. Every pipeline marker contains information identifying the company that operates the pipeline, the product transported, and a phone number that should be called in the event of an emergency. **Markers do not indicate pipeline burial depth, which will vary.** Markers are typically seen where a pipeline intersects a street, highway or railway. For any person to willfully deface, damage, remove, or destroy any pipeline marker is a federal crime.



Pipeline Marker — This marker is the most common. It contains operator information, type of product, and an emergency contact number. Size, shape and color may vary.

Aerial Marker — These skyward facing markers are used by patrol planes that monitor pipeline routes.

Casing Vent Marker — This marker indicates that a pipeline (protected by a steel outer casing) passes beneath a nearby roadway, rail line or other crossing.

What does Crimson do if a leak occurs?

To prepare for the event of a leak, Crimson regularly communicates, plans and trains with local emergency responders. Upon the notification of an incident or leak Crimson will immediately dispatch trained personnel to assist emergency responders. Crimson and emergency responders are trained to protect life, property and facilities in the case of an emergency. Crimson will also take steps to minimize the amount of product that leaks out and isolate the pipeline emergency.

How would you recognize a pipeline leak?

- **Sight:** Liquid pools, discolored or abnormally dry soil/vegetation, continuous bubbling in wet or flooded areas, an oily sheen on water surfaces, and vaporous fogs or blowing dirt around a pipeline area can all be indicative of a pipeline leak. Dead or discolored plants in an otherwise healthy area of vegetation or frozen ground in warm weather are other possible signs.
- **Sound:** Volume can range from a quiet hissing to a loud roar depending on the size of the leak and pipeline system.
- **Smell:** An unusual smell, petroleum odor, or gaseous odor will sometimes accompany pipeline leaks.

What to do in the event a leak were to occur:

- **Turn off** any equipment and eliminate any ignition sources without risking injury.
- **Leave the area** by foot immediately. Try to direct any other bystanders to leave the area. Attempt to stay upwind.
- If known, from a safe location, **call 911** or your local emergency response number and notify Crimson immediately. Give your name, your phone number, a brief description of the incident, and the location so the proper response can be initiated.

What not to do in the event a leak were to occur:

- **DO NOT** cause any open flame or other potential source of ignition such as an electrical switch, vehicle ignition, light a match, etc. Do not start motor vehicles or electrical equipment. Do not ring doorbells to notify others of the leak. Knock with your hand to avoid potential sparks from knockers.
- **DO NOT** come into direct contact with any escaping liquids.
- **DO NOT** drive into a leak or vapor cloud while leaving the area.
- **DO NOT** attempt to operate any pipeline valves yourself. You may inadvertently route more product to the leak or cause a secondary incident.
- **DO NOT** attempt to extinguish a petroleum product fire. Wait for local firemen and other professionals trained to deal with such emergencies.

Maintaining safety and integrity of pipelines

Crimson invests significant time and capital maintaining the quality and integrity of their pipeline systems. Our pipelines are monitored 24 hours a day via manned control centers in Bakersfield, CA. Crimson also utilizes aerial surveillance and/or on-ground observers to identify potential dangers. Crimson's control center personnel continually monitor the pipeline system and assess changes in pressure and flow. They notify field personnel if there is a possibility of a leak. Automatic shut-off valves are sometimes utilized to isolate a leak.

Gas transmission and hazardous liquid pipeline operators have developed supplemental hazard and assessment programs for areas designated as "high consequence areas" in accordance with federal regulations.

What to do in case of damaging/disturbing a pipeline

If you cause or witness even minor damage to a pipeline or its protective coating, please immediately notify Crimson. Even a small disturbance to a pipeline may cause a future leak. A gouge, scrape, dent or crease is cause enough for Crimson to inspect the damage and make repairs.

All damages to underground gas or hazardous liquid pipeline facilities in the State of California are required by law to be reported to the California State Fire Marshal at osfm.fire.ca.gov. Excavators must notify the pipeline company through the One-Call Center immediately but not later than two hours following the damage incident.

What is a right-of-way and can I build or dig on it?

Crimson works diligently to establish written agreements, or easements, with landowners to allow for ease of construction and maintenance when they cross private property. Rights-of-way (ROW) are often recognizable as corridors that are clear of trees, buildings or other structures except for the pipeline markers. A ROW may not have markers clearly present and may only be indicated by cleared corridors of land, except where farm land or crops exist. County Clerk's Offices also have record of easements which are public record.

Encroachments upon the pipeline right-of-way inhibit the Crimson's ability to reduce the chance of third-party damage, provide right-of-way surveillance and perform routine maintenance and required federal/state inspections. In order to perform these critical activities, Crimson maintenance personnel must be able to easily and safely access the pipeline right-of-way, as well as areas on either side of the pipeline. Keeping trees, shrubs, buildings, fences, structures and any other encroachments well away from the pipeline ensures that the pipeline integrity and safety are maintained.

For questions concerning the pipeline or right-of-way or about future property improvements or excavations, contact Crimson.

Pipeline purpose and reliability

Pipelines are the safest and most efficient means of transporting natural gas and petroleum products, according to National Transportation Safety Board statistics. In the United States alone, there are over 200,000 miles of petroleum pipelines and 300,000 miles of natural gas transmission pipelines in use every day. These pipelines transport the natural gas, which provides about 24 percent of all the energy used in the United States, and over 700 million gallons of petroleum products per day.

How can you help?

While accidents pertaining to pipeline facilities are rare, awareness of the location of the pipeline, the potential hazards, and what to do if a leak occurs can help minimize the number of accidents. A leading cause of pipeline incidents is third-party excavation damage. Crimson is responsible for the safety and security of their pipelines. To help maintain the integrity of pipelines and their rights-of-way, it is essential that pipeline and facility neighbors protect against unauthorized excavations or other destructive activities. Here's what you can do to help:

- Become familiar with the pipelines and pipeline facilities in the area (marker signs, fence signs at gated entrances, etc).
- Record the operator name, contact information and any pipeline information from nearby marker/facility signs and keep in a permanent location near the telephone.
- Be aware of any unusual or suspicious activities or unauthorized excavations taking place within or near the pipeline right-of-way or pipeline facility; report any such activities to the pipeline operator and the local law enforcement.

Llame antes de cavar. ¡ES LA LEY!

Crimson Pipeline tiene un Programa de Prevención de Daños en conformidad con los requisitos estatales y federales. El propósito de este programa es prevenir daños a nuestras líneas de tuberías y a nuestras instalaciones causados por actividades de excavación, tales como cavar, hacer zanjas, detonar, perforar, hacer túneles, rellenar, o por cualquier otra actividad de excavación.

Una fácil llamada telefónica **GRATIS** al 811 da comienzo al proceso para que marquen sus líneas de tuberías subterráneas y de servicios de utilidades. Cuando usted llama al 811 desde cualquier lugar del país, su llamada será transferida al Centro de Una-Llamada de su estado. Una vez que sus líneas subterráneas han sido marcadas para su proyecto, usted podrá saber la ubicación aproximada de sus líneas de tuberías y líneas de servicios de utilidades y podrá comenzar a excavar con seguridad. Usted puede encontrar más información acerca del 811 en el sitio web www.call811.com.



Determina lo que está **bajo tierra.**
Llama antes de excavar.

¿Cómo puede usted saber donde se encuentra una línea de tubería?

La mayoría de las líneas de tuberías se encuentran debajo de la tierra, donde están mejor protegidas de los elementos y donde minimizan la interferencia con usos en la superficie. Aun así, los derechos de paso de las líneas de tubería están claramente identificados con marcadores de líneas de tuberías a lo largo de la ruta de la línea de tubería, los cuales identifican la ubicación aproximada—NO EXACTA—de la línea de tubería. Cada marcador de la línea de tubería contiene información que identifica la compañía que opera la línea de tubería, el producto transportado y un número de teléfono al cual se debe llamar en caso de una emergencia. **Los marcadores no indican la profundidad a la cual una línea de tubería se encuentra enterrada, la cual puede variar.** Los marcadores se pueden ver típicamente donde una línea de tubería atraviesa una calle, autopista o ferrocarril. Es un delito federal que cualquier persona voluntariamente estropee, dañe, quite o destruya un marcador de una línea de tubería.



Marcador de Líneas de Tuberías — Este tipo de marcador es el más común. Contiene la información del operador, tipo de producto y un número de contacto en caso de una emergencia. El tamaño, forma y color puede variar.

Marcador Aéreo — Estos marcadores colocados mirando hacia el cielo son usados por los aviones de patrullas que monitorean las rutas de las líneas de tuberías.

Marcador de Tubos de Ventilación — Este marcador indica que una línea de tubería (protegida por un revestimiento de acero) pasa por debajo de una carretera, ferrocarril u otro cruce.

¿Qué hace Crimson en el caso que ocurra una fuga?

Para preparar para el acontecimiento de una filtración, Crimson comunica regularmente, los planes y los trenes con contestadores locales de emergencia. Cuando se notifica un incidente o una fuga, Crimson enviará inmediatamente a un personal entrenado para asistir a los respondedores de emergencias. Crimson y los respondedores de emergencias están entrenados para proteger vidas, propiedades y las instalaciones en el caso de que ocurra una emergencia. Crimson también tomarán los pasos necesarios para minimizar la cantidad de producto que se escapa y aislar la emergencia en la línea de tubería.

¿Cómo puede usted reconocer una fuga en una línea de tuberías?

- **Vista:** Charcos de líquido, terreno/vegetación descolorida o anormalmente seca, burbujeo continuo en áreas mojadas o inundadas, un brillo aceitoso en la superficie del agua, niebla de vapor o tierra volando en el aire pueden ser indicios de que ocurre una fuga en la línea de tubería. Otros posibles indicios son la presencia de plantas descoloridas o muertas o terreno congelado durante temporada caliente.
- **Sonido:** El volumen del ruido puede ser desde un silbido silencioso hasta un rugido fuerte, dependiendo del tamaño de la fuga y del sistema de líneas de tuberías.
- **Olor:** Un olor inusual, olor a petróleo o un olor gaseoso puede a veces salir de una fuga en una línea de tuberías.

Lo que si debe hacer en el caso de que ocurriese una fuga:

- **Apague** cualquier equipo y elimine cualquier fuente de encendido sin ponerse en riesgo a sí mismo.
- Inmediatamente **salga del área** caminando. Trate de avisar a otras personas que se encuentren cerca para que se alejen del área. Intente mantenerse en contra del viento.
- Si conocido, de una ubicación segura, **la llamada 911** o su número local de respuesta de emergencia y notifica Crimson inmediatamente. Dé su nombre, su número de teléfono, una descripción breve del incidente, y de la ubicación tan la respuesta apropiada puede ser iniciada.

Lo que no debe hacer en el caso de que ocurriese una fuga:

- **NO** cause ninguna llama ni use otras fuentes potenciales de encendido tales como los interruptores de electricidad, vehículos de ignición, fósforos, etc. No encienda ningún vehículo de motor ni equipo eléctrico. No toque ningún timbre de casa para notificar a las personas acerca de la fuga. Golpee la puerta con su mano para evitar crear chispas con la aldabas.
- **NO** se ponga en contacto directo el líquido que se esté escapando.
- **NO** maneje hacia ninguna fuga ni nube de vapor cuando esté saliendo del área.
- **NO** intente operar usted mismo ninguna válvula. Sin quererlo, usted podría dirigir mas producto hacia la fuga o causar otro incidente.
- **NO** intente extinguir un fuego de productos de petróleo o gas natural. Espere a que los bomberos locales y otros profesionales entrenados manejen la emergencia.

Conservando la seguridad y la integridad de las líneas de tuberías

Crimson invierte tiempo y capital significativos que mantienen la calidad y la integridad de sus sistemas de ducto. Nuestros ductos son vigilados las 24 horas del día a través de centros tripulados de control en Bakersfield, CA. Crimson también utiliza a observadores aéreos de vigilancia y/o en-suelo para identificar peligros potenciales. El personal de Crimson monitorea continuamente el sistema de líneas de tuberías y evalúa cambios en la presión y el flujo. Ellos notifican al personal en el campo si existe la posibilidad de una fuga. En ocasiones se utilizan válvulas que se cierran automáticamente para aislar una fuga.

Asfíxie con gas transmisión y operarios líquidos peligrosos de ducto han desarrollado programas suplementarios de peligro y evaluación para áreas designadas como "áreas altas de consecuencia" de acuerdo con regulaciones federales.

Lo que usted debe hacer en el caso que dañe/disturbe una línea de tubería

Si usted ocasiona o tiene conocimiento de algún daño, por más mínimo que sea, a una línea de tubería o a su capa protectora, por favor notifique inmediatamente Crimson. Aun un daño pequeño a una línea de tubería, puede causar una fuga en el futuro. Un agujero, arañazo, dobladura o una arruga pueden ser una causa suficiente para Crimson de inspeccionar el daño y hacer reparaciones.

En el estado de California, la ley exige que todo daño hecho a una instalación de líneas de tuberías enterradas de gas o de líquidos peligrosos sea reportado a la California State Fire Marshal a través del internet en www.osfm.fire.ca.gov. Los excavadores deben notificar inmediatamente a la compañía de la línea de tubería a través del Centro de Una-Llamada o a no más tardar de dos horas después que haya ocurrido cualquier incidente de daños.

¿Cómo usted puede ayudar?

Aunque los accidentes concernientes a las instalaciones de líneas de tuberías son poco comunes, el estar al tanto de la ubicación de la línea de tubería, los peligros potenciales y lo que usted debe hacer si ocurre una fuga, puede minimizar el número de accidentes. Una de las causas principales de los incidentes en líneas de tuberías es el daño ocasionado es la excavación por terceras personas. Crimson es responsable de la seguridad de sus ductos. Para poder conservar la integridad de las líneas de tuberías y de los derechos de paso, es esencial que los vecinos de las instalaciones y de las líneas de tuberías las protejan contra excavaciones no autorizadas y contra actividades destructivas. A continuación listamos lo que usted puede hacer para ayudar:

- Familiarícese con las líneas de tuberías y las instalaciones de líneas de tuberías en el área (señales de marcadores, señales en las cercas de los lugares cercados, etc.).
- Escriba el nombre del operador, información de contacto y cualquier otra información de la línea de tubería que se encuentre en cualquier señal o marcador que se encuentre cerca de usted y mantenga esa información cerca del teléfono.
- Esté al tanto de cualquier actividad sospechosa o cualquier excavación no autorizada que se esté haciendo dentro o cerca del derecho de paso de la línea de tubería o de las instalaciones de líneas de tuberías; informe cualquiera de estas actividades al operador de la línea de tubería y a los oficiales locales de la ley.

¿Qué es un derecho de paso y puedo yo construir o cavar en ellos?

Crimson trabajan diligentemente para establecer acuerdos escritos, o servidumbres con los dueños de terreno para así permitir la facilidad de construcción y mantenimiento cuando estas compañías atraviesan la propiedad privada. Los Derechos de Paso ("ROW" por sus siglas en inglés) usualmente son reconocidos como pasillos en el terreno que están libres de árboles, edificios y de otras estructuras con excepción de los marcadores de líneas de tuberías. Un "ROW" puede que no tenga marcadores claramente visibles y puede que solo sean evidentes al ver los pasillos de terreno libres, con excepción en donde existen granjas o plantaciones. Las oficinas del Secretario del Condado también tienen registros de las servidumbres los cuales son información pública.

Las invasiones en los derechos de paso de la línea de tubería impiden la habilidad Crimson de poder reducir la posibilidad de daños por terceras personas, de proveer vigilancia en el derecho de paso y de realizar mantenimiento rutinario e inspecciones requeridas federalmente y estatalmente. Para poder realizar estas actividades críticas, el personal de mantenimiento de Crimson debe poder tener acceso de una manera fácil y segura al derecho de paso de la línea de tubería, también como a las áreas a cada lado de la línea de tubería. Al mantener los árboles, arbustos, edificios, cercas, estructuras y cualquier otra invasión muy lejos de la línea de tubería asegura que la integridad y seguridad en la línea de tubería sean conservadas.

Para preguntas concernientes al derecho de paso de la línea de tubería o acerca de mejoras futuras a la propiedad o de excavaciones, póngase en contacto con el Crimson.

Propósito y Confiabilidad de la línea de tubería

Según las estadísticas de la Junta Nacional de Seguridad de Transporte (National Transportation Safety Board), las líneas de tuberías son el método más seguro y eficiente para transportar el gas natural y los productos de petróleo. Tan solo en los Estados Unidos, existen más de 200,000 millas (322.000 kilómetros) de líneas de tuberías de petróleo y 300,000 millas (483.000 kilómetros) de líneas de tuberías de transmisión de gas natural en uso cada día. Estas líneas de tuberías transportan el gas natural y proveen aproximadamente el 24 por ciento de toda la energía que se usa en los Estados Unidos y más de 700 millones de galones (2 billones de litros) de productos de petróleo al día.

Transmission Pipeline Mapping

The U.S. Department of Transportation's Office of Pipeline Safety has developed the National Pipeline Mapping System (NPMS) to provide information about gas transmission and liquid transmission operators and their pipelines. The NPMS Web site is searchable by zip code or by county and state, and can display a county map that is printable. For a list of pipeline operators with pipelines in your area and their contact information, go to www.npms.phmsa.dot.gov/. Operators of production facilities, gas/liquid gathering piping and distribution piping, are not represented by NPMS nor are they required to be.









Mapas de Líneas de Tubería de Transmisión

La Oficina Estadounidense del Departamento de Transporte de Seguridad en Líneas de Tubería ha desarrollado el Sistema Nacional de Mapas de Líneas de Tubería ("NPMS" por sus iniciales en inglés) para proporcionar información acerca de los operadores de líneas de tubería y de sus mismas líneas de tuberías. El Sitio web de "NPMS" puede ser buscado en el internet usando el CÓDIGO POSTAL o el nombre del condado y estado, y en el mismo sitio usted puede adquirir un mapa del condado, el cual que puede ser impreso desde cualquier impresora personal. Para obtener una lista de los operadores con líneas de tuberías en su área y su información de cómo contactarlos, visite la pagina www.npms.phmsa.dot.gov/. Los operadores de las instalaciones de producción, tuberías de recolección de gas/líquido y las tuberías de distribución, no están representados por el "NPMS" ni tampoco se requiere que lo estén.









The information provided in this brochure, including but not limited to, One-Call center information, Web sites, state laws, regulatory agencies, has been gathered using the most up to date information available, and provided for informational purposes only. All matter is subject to change without notice. The Paradigm Alliance, Inc. made an attempt to verify all information contained herein as to its accuracy, and is not liable for any missing or incorrect information.

La información proporcionada en este folleto, incluyendo pero no limitado a, One-Call centro de información, sitios Web, las leyes estatales, los organismos reguladores, se ha obtenido utilizando las más modernas a la información actualizada disponible, y ofrece con fines informativos solamente. Toda la materia está sujeta a cambios sin previo aviso. La Alianza Paradigm, Inc., hizo un intento de verificar toda la información contenida en este documento en cuanto a su exactitud, y no es responsable de la información faltante o incorrecta.

This color code chart will help determine which utilities have marked their underground utility lines.

| | | | |
|---|--|---|--|
|  | WHITE - Proposed excavation |  | ORANGE - Communications, alarm or signal lines, cables or conduit |
|  | PINK - Temporary survey markings |  | BLUE - Potable water lines |
|  | RED - Electric power lines, cables, conduit and lighting cables |  | PURPLE - Reclaimed water, irrigation and slurry lines |
|  | YELLOW - Gas, oil, steam, petroleum or gaseous materials |  | GREEN - Sewer lines |

Este gráfico del código del color ayudará a determinar cuál utilidades han marcado sus líneas subterráneas de la utilidad.

| | | | |
|---|---|---|--|
|  | BLANCO - Excavación Propuesta |  | ANARANJADO - Comunicación, las Líneas de la Alarma o la Señal, Cablegrafía o Conduito |
|  | ROSA - Las Marcas Temporarias de la Inspección |  | AZUL - Agua Potable |
|  | ROJO - Eléctrico, Líneas de fuerza, los Cables, Conduito e Iluminación Cablegrafía |  | PURPURA - Agua Recuperada, la Irrigación y la Lechada Forran |
|  | AMARILLO - Gas, Engrasa, el Vapor, el Petróleo o las Materias Gaseosas |  | VERDE - Alcantarillas y Desagua las Líneas |

For more information regarding pipeline safety and an overview of the pipeline industry please visit the following Web sites:

Pipeline Resources and Information

- Pipeline 101 - www.pipeline101.com
- Association of Oil Pipe Lines (AOPL) - www.aopl.org
- American Petroleum Institute (API) - www.api.org
- In the Pipe - Newsletter from the Oil Pipeline Industry - www.enewsbuilder.net/aopl/
- Interstate Natural Gas Association of America (INGAA) - www.ingaa.org
- American Gas Association (AGA) - www.aga.org
- Dig Safely - www.digsafely.com
- Common Ground Alliance (CGA) - www.commongroundalliance.com

Regulatory Agencies

- Department of Transportation (DOT) - www.dot.gov
- Office of Pipeline Safety (OPS) - phmsa.dot.gov
- National Transportation and Safety Board (NTSB) - www.nts.gov
- Federal Energy Regulatory Commission (FERC) - www.ferc.gov
- Federal Energy Regulatory Commission (FERC - Oil Pipelines) - www.ferc.gov/industries/oil.asp
- Occupational Safety & Health Administration (OSHA) - www.osha.gov
- National Fire Protection Association (NFPA) - www.nfpa.org

STATE ONE-CALL CENTERS:

| ONE-CALL INFORMATION | STATE LEGISLATION | COVERAGE/STATEWIDE | MANDATORY MEMBERSHIP | CIVIL PENALTIES | TOLERANCE ZONE | HAND DIG CLAUSE | MANDATORY PREMARK | EMERGENCY CLAUSE | POSITIVE RESPONSE | EXCAVATOR PERMIT ISSUED | DOT EXEMPTION | DEPTH | HOME OWNER EXEMPTION | RAILROAD EXEMPTION | AGRICULTURE EXEMPTION | MAPPING SYSTEM | INTERNET TICKETS | FAX |
|--|-------------------|--------------------|----------------------|-----------------|----------------|-----------------|-------------------|------------------|-------------------|-------------------------|---------------|-------|----------------------|--------------------|-----------------------|----------------|------------------|-----|
| California: Underground Service Alert North (800) 227-2600 www.usanorth.org Notice: 2 working days, but not more than 14 calendar days | Y | N | Y | Y | 24" | Y | Y | Y | Y | Y | Y | N | Y | N | N | Y | Y | N |
| California: Underground Service Alert Southern California (800) 227-2600 www.digalert.org Notice: 2 working days, but not more than 14 calendar days | Y | N | Y | Y | 24" | Y | Y | Y | Y | Y | Y | N | Y | N | N | Y | Y | N |

REGULATORY AGENCIES:

California Public Utilities Commission

213-576-7000

Website: <http://www.cpuc.ca.gov/>

Office of California State Fire Marshal

562-497-9102

Website: <http://osfm.fire.ca.gov/pipeline/pipeline.php>

PRODUCTS TRANSPORTED IN YOUR AREA*

| PRODUCT | LEAK TYPE | VAPORS |
|--|---|--|
| HAZARDOUS LIQUIDS [SUCH AS: CRUDE OIL, DIESEL FUEL, JET FUEL, GASOLINE, AND OTHER REFINED PRODUCTS] | Liquid | Initially heavier than air and spread along ground and collect in low or confined areas. Vapors may travel to source of ignition and flash back. Explosion hazards indoors, outdoors or in sewers. |
| HEALTH HAZARDS | Inhalation or contact with material may irritate or burn skin and eyes. Fire may produce irritating, corrosive and/or toxic gases. Vapors may cause dizziness or suffocation. Runoff from fire control or dilution water may cause pollution. | |

PRODUCTOS TRANSPORTADOS EN SU AREA*

| PRODUCTO | TIPO DE FUGA | VAPORES |
|---|--|--|
| LIQUIDOS PELIGROSOS [TALES COMO: PETROLEO CRUDO, COMBUSTIBLE DIESEL, COMBUSTIBLE PARA AVIONES, GASOLINA Y OTROS PRODUCTOS REFINADOS] | Líquido | Inicialmente es más pesado que el aire, se esparce en el suelo y se acumula en lugares bajos y confinados. Los vapores pueden viajar hasta la fuente de incendio y causar un retroceso de llamas. Peligro de explosión en interiores, exteriores o en alcantarillados. |
| RIESGOS DE SALUD | La inhalación o el contacto con esta materia pueden irritar o quemar la piel y los ojos. El fuego puede producir gases irritantes, corrosivos y/o tóxicos. Los vapores pueden causar mareos y asfixia. Los residuos del fuego controlado o del agua diluida pueden causar contaminación. | |





California State Fire Marshal Information Bulletin 03-001

Issued: June 20, 2003
(Revised September 25, 2019)

ENCROACHMENTS INTO or ON PIPELINE EASEMENTS

The purpose of this informational bulletin is to delineate the position of the State Fire Marshal regarding encroachments onto the pipeline easements.

Section 51014.6 of the California Government Code states, "(a) Effective January 1, 1987, no person, other than the pipeline operator, shall do any of the following with respect to any pipeline easement: (1) Build, erect, or create a structure or improvement within the pipeline easement or permit the building, erection, or creation thereof. (2) Build, erect, or create a structure, fence, wall, or obstruction adjacent to any pipeline easement which would prevent complete and unimpaired surface access to the easement, or permit the building, erection, or creation thereof. (b) No shrubbery or shielding shall be installed on the pipeline easement which would impair aerial observation of the pipeline easement. This subdivision does not prevent the revegetation of any landscape disturbed within a pipeline easement as a result of construction the pipeline and does not prevent the holder of the underlying fee interest or the holder's tenant from planting and harvesting seasonal agricultural crops on a pipeline easement. (c) This section does not prohibit a pipeline operator from performing any necessary activities within a pipeline easement, including, but not limited to, the construction, replacement, relocation, repair, or operation of the pipeline.

It is the position of the State Fire Marshal that nothing shall encroach into or upon the pipeline easement, which would impede the pipeline operator from complete and unobstructed surface access along the pipeline right of way. Nor shall there be any obstructions, which would shield the pipeline right of way from observation. In the interest of public safety and the protection of the environment, it is imperative that the pipeline operator visually assesses the conditions along the easement to ensure the integrity of the pipeline.

It is the responsibility of the pipeline operator to ensure they have unimpeded surface access and to be able to physically observe all portions of their pipeline rights of way. In cases where this is not possible, the pipeline operator shall inform the State Fire Marshal. The State Fire Marshal shall in conjunction with the pipeline operator resolve the issue.

Questions regarding the issue of pipeline encroachment can be addressed to:

CAL FIRE-Office of the State Fire Marshal
Pipeline Safety Division
3780 Kilroy Airport Way #500
Long Beach, CA 90806

Phone:(562) 497-0350



Guidelines for Design and Construction near Kinder Morgan Hazardous Liquid Operated Facilities

Name of Company: _____

The list of design, construction and contractor requirements, including but not limited to the following, for the design and installation of foreign utilities or improvements on KM right-of-way (ROW) are not intended nor do they waive or modify any rights KM may have under existing easements or ROW agreements. Reference existing easements and amendments for additional requirements. This list of requirements is applicable for KM facilities on easements only. Encroachments on fee property should be referred to the ROW Department.

Design

- KM shall be provided sufficient prior notice of planned activities involving excavation, blasting, or any type of construction on KM's ROW to determine and resolve any location, grade or encroachment problems and provide protection of our facilities and the public **before** the actual work is to take place.
- Encroaching entity shall provide KM with a set of drawings for review and a set of final construction drawings showing all aspects of the proposed facilities in the vicinity of KM's ROW. The encroaching entity shall also provide a set of as-built drawings showing the proposed facilities in the vicinity of KM's ROW.
- Only facilities shown on drawings reviewed by _____ (Company) will be approved for installation on KM's ROW. All drawing revisions that effect facilities proposed to be placed on KM's ROW must be approved by KM in writing.
- KM shall approve the design of all permanent road crossings.
- Any repair to surface facilities following future pipeline maintenance or repair work by KM will be at the expense of the developer or landowner.
- The depth of cover over the KM pipelines shall not be reduced nor drainage altered without KM's written approval.
- Construction of any permanent structure, building(s) or obstructions within KM pipeline easement is **not** permitted.
- Planting of shrubs and trees is not permitted on KM pipeline easement.
- Irrigation equipment i.e. backflow prevent devices, meters, valves, valve boxes, etc. shall not be located on KM easement.
- Foreign line, gas, water, electric and sewer lines, etc., may cross perpendicular to KM's pipeline within the ROW, provided that a minimum of two (2) feet of vertical clearance is maintained between KM pipeline(s) and the foreign pipeline. Constant line elevations must be maintained across KM's entire ROW width, gravity drain lines are the only exception. Foreign line crossings below the KM pipeline must be evaluated by KM to ensure that a significant length of the KM line is not exposed and unsupported during construction. When installing underground utilities, the last line should be placed beneath all existing lines unless it is impractical or unreasonable to do so. Foreign line crossings above the KM pipeline with less than 2 feet of clearance must be evaluated by KM to ensure that additional support is not necessary to prevent settling on top of the KM hazardous liquids pipeline.
- A foreign pipeline shall cross KM facilities at as near a ninety-degree angle as possible. A foreign pipeline shall not run parallel to KM pipeline within KM easement without written permission of KM.
- The foreign utility should be advised that KM maintains cathodic protection on their pipelines. The foreign utility must coordinate their cathodic protection system with KM's. At the request of KM, foreign utilities shall install (or allow to be installed) cathodic protection test leads at all crossings for the purposes of monitoring cathodic protection. The KM Cathodic Protection (CP) technician and the foreign utility CP technician shall perform post construction CP interference testing. Interference issues shall be resolved by mutual agreement between foreign utility and KM. All costs associated with the correction of cathodic protection problems on KM pipeline as a result of the foreign utility crossing shall be borne by the foreign utility for a period of one year from date the foreign utility is put in service.
- The metallic foreign line shall be coated with a suitable pipe coating for a distance of at least 10 feet on either side of the crossing unless otherwise requested by the KM CP Technician.



Guidelines for Design and Construction near Kinder Morgan Hazardous Liquid Operated Facilities

- AC Electrical lines must be installed in conduit and properly insulated.
- DOT approved pipeline markers shall be installed so as to indicate the route of the foreign pipeline across the KM ROW.
- No power poles, light standards, etc. shall be installed on KM easement
- No pipeline may be located within 50 feet (15 meters) of any private dwelling, or any industrial building or place of public assembly in which persons work, congregate, or assemble.

Construction

- Contractors shall be advised of KM's requirements and be contractually obligated to comply.
- The continued integrity of KM's pipelines and the safety of all individuals in the area of proposed work near KM's facilities are of the utmost importance. Therefore, contractor must meet with KM representatives prior to construction to provide and receive notification listings for appropriate area operations and emergency personnel. **KM's on-site representative will require discontinuation of any work that, in his opinion, endangers the operations or safety of personnel, pipelines or facilities.**
- The Contractor must expose all KM pipelines prior to crossing to determine the exact alignment and depth of the lines. A KM representative must be present. In the event of parallel lines, only one pipeline can be exposed at a time.
- KM will not allow pipelines to remain exposed overnight without consent of KM designated representative. Contractor may be required to backfill pipelines at the end of each day.
- A KM representative shall do all line locating. A KM representative shall be present for hydraulic excavation. The use of probing rods for pipeline locating shall be performed by KM representatives only, to prevent unnecessary damage to the pipeline coating.
- Notification shall be given to KM at least 72 hours before start of construction. A schedule of activities for the duration of the project must be made available at that time to facilitate the scheduling of Kinder Morgan, Inc.'s work site representative. Any Contractor schedule changes shall be provided to Kinder Morgan, Inc. immediately.
- Heavy equipment will not be allowed to operate directly over KM pipelines or in KM ROW unless written approval is obtained from (Company). Heavy equipment shall only be allowed to cross KM pipelines at locations designated by Kinder Morgan, Inc. Contractor shall comply with all precautionary measures required by KM to protect its pipelines. When inclement weather exists, provisions must be made to compensate for soil displacement due to subsidence of tires. Equipment excavating within ten (10) feet of KM Pipelines will have a plate guard installed over the teeth to protect the pipeline.
- Excavating or grading which might result in erosion or which could render the KM ROW inaccessible shall not be permitted unless the contractor/developer/owner agrees to restore the area to its original condition and provide protection to KM's facility.
- A KM representative shall be on-site to observe any construction activities within ten (10) feet of a KM pipeline or aboveground appurtenance. The contractor **shall not** work within this distance without a KM representative being on site. Only hand excavation shall be permitted within **two (2) feet** of KM pipelines, valves and fittings unless State requirements are more stringent. However, proceed with extreme caution when within three (3) feet of the pipe.
- A KM representative will monitor construction activity within 25 feet of KM facilities during and after the activities to verify the integrity of the pipeline and to ensure the scope and conditions agreed to have not changed. Monitoring means to conduct site inspections on a pre-determined frequency based on items such as: scope of work, duration of expected excavator work, type of equipment, potential impact on pipeline, complexity of work and/or number of excavators involved.
- Ripping is only allowed when the position of the pipe is known and not within ten (10) feet of KM facility unless company representative is present.
- Temporary support of any exposed KM pipeline by Contractor may be necessary if required by KM's on-site representative. Backfill below the exposed lines and 12" above the lines shall be replaced with sand or other selected material as approved by KM's on-site representative and thoroughly compacted in 12" lifts to 95% of standard proctor dry density minimum or as approved by KM's on-site representative. This is to adequately protect against stresses that may be caused by the settling of the pipeline.



Guidelines for Design and Construction near Kinder Morgan Hazardous Liquid Operated Facilities

- No blasting shall be allowed within 1000 feet of KM's facilities unless blasting notification is given to KM including complete Blasting Plan Data. A pre-blast meeting shall be conducted by the organization responsible for blasting. KM shall be indemnified and held harmless from any loss, cost of liability for personal injuries received, death caused or property damage suffered or sustained by any person resulting from any blasting operations undertaken within 500 feet of its facilities. The organization responsible for blasting shall be liable for any and all damages caused to KM's facilities as a result of their activities whether or not KM representatives are present. KM shall have a signed and executed Blasting Indemnification Agreement before authorized permission to blast can be given.

No blasting shall be allowed within 300 feet of KM's facilities unless blasting notification is given to KM a minimum of one week before blasting. *(note: covered above)* KM shall review and analyze the blasting methods. A written blasting plan shall be provided by the organization responsible for blasting and agreed to in writing by KM in addition to meeting requirements for 500' and 1000' being met above. A written emergency plan shall be provided by the organization responsible for blasting. *(note: covered above)*

- **Any** contact with any KM facility, pipeline, valve set, etc. shall be reported immediately to KM. If repairs to the pipe are necessary, they will be made and inspected before the section is re-coated and the line is back-filled.
- KM personnel shall install all test leads on KM facilities.
- Burning of trash, brush, etc. is not permitted within the KM ROW.

Insurance Requirements

- All contractors, and their subcontractors, working on Company easements shall maintain the following types of insurance policies and minimum limits of coverage. All insurance certificates carried by Contractor and Grantee shall include the following statement: "Kinder Morgan and its affiliated or subsidiary companies are named as additional insured on all above policies (except Worker's Compensation) and waiver of subrogation in favor of Kinder Morgan and its affiliated or subsidiary companies, their respective directors, officers, agents and employees applies as required by written contract." **Contractor shall furnish Certificates of Insurance evidencing insurance coverage prior to commencement of work and shall provide thirty (30) days notice prior to the termination or cancellation of any policy.**
- 1. Statutory Coverage Workers' Compensation Insurance in accordance with the laws of the states where the work is to be performed. If Contractor performs work on the adjacent on navigable waterways Contractor shall furnish a certificate of insurance showing compliance with the provisions of the Federal Longshoreman's and Harbor Workers' Compensation Law.
- 2. Employer's Liability Insurance, with limits of not less than **\$1,000,000** per occurrence and **\$1,000,000** disease each employee.
- 3. Commercial General Liability Insurance with a combined single limit of not less than **\$2,000,000** per occurrence and in the aggregate. All policies shall include coverage for blanket contractual liability assumed.
- 4. Comprehensive Automobile Liability Insurance with a combined single limit of not less than **\$1,000,000**. If necessary, the policy shall be endorsed to provide contractual liability coverage.
- 5. If necessary Comprehensive Aircraft Liability Insurance with combined bodily injury, including passengers, and property damage liability single limits of not less than **\$5,000,000** each occurrence.
- 6. Contractor's Pollution Liability Insurance this coverage shall be maintained in force for the full period of this agreement with available limits of not less then **\$2,000,000** per occurrence.
- 7. Pollution Legal Liability Insurance this coverage must be maintained in a minimum amount of **\$5,000,000** per occurrence.

EXHIBIT B
INSURANCE REQUIREMENTS

Contractor shall maintain and shall require all of its subcontractors, consultants, and other agents to maintain the insurance listed below. Any requirement for insurance to be maintained after completion of the work shall survive this agreement.

CITY reserves the right to review any and all of the required insurance policies and/or endorsements, but has no obligation to do so. Failure to demand evidence of full compliance with the insurance requirements set forth in this agreement or failure to identify any insurance deficiency shall not relieve Contractor from, nor be construed or deemed a waiver of, its obligation to maintain the required insurance at all times during the performance of this agreement.

A. Workers Compensation & Employers Liability Insurance

- Workers Compensation insurance with statutory limits as required by the Labor Code of the State of California.
- Employers Liability with limits of \$1,000,000 per Accident; \$1,000,000 Disease per employee; \$1,000,000 Disease per policy.
- The policy shall include a written waiver of the insurer's right to subrogate against CITY.
- Required Evidence Of Coverage:
 1. Subrogation waiver endorsement; and
 2. Properly completed Certificate of Insurance.

B. General Liability Insurance

- Commercial General Liability Insurance no less broad than Insurance Services Office (ISO) form CG 00 01.
- Coverage shall be on a standard occurrence form. Claims-Made forms are not acceptable without prior written consent. Modified, limited or restricted Occurrence forms are not acceptable without prior written consent.
- Minimum Limits: \$2,000,000 per Occurrence; \$4,000,000 General Aggregate; \$4,000,000 Products/Completed Operations Aggregate. The General Aggregate shall apply separately to each project. The required limits may be provided by a combination of General Liability Insurance and Commercial Excess or Umbrella Liability Insurance. If contractor maintains higher limits than the specified minimum limits, CITY requires and shall be entitled to coverage for the higher limits maintained by contractor.
- Any deductible or self-insured retention shall be shown on the Certificate of Insurance. If the deductible or self-insured retention exceeds \$25,000 it must be approved in advance by CITY. Contractor is responsible for any deductible or self-insured retention and shall fund it upon CITY'S written request, regardless of whether Contractor has a claim against the insurance or is named as a party in any action involving CITY.
- Coverage shall be continued for one (1) year after completion of the work.
- CITY shall be endorsed as an additional insured for liability arising out of ongoing and completed operations by or on behalf of the contractor. CITY shall continue to be an additional insured for completed operations for (1) year after completion of the work.
- The policy definition of "insured contract" shall include assumptions of liability

arising out of both ongoing operations and the products-completed operations hazard (“P” definition of insured contract in ISO form CG 00 01, or equivalent).

- The insurance provided to the additional insureds shall be primary to, and non-contributory with, any insurance or self-insurance program maintained by them.
- The policy shall cover inter-insured suits and include a “Separation of Insureds” or “severability” clause which treats each insured separately.
- The policy shall be endorsed to include a written waiver of the insurer’s right to subrogate against all persons or entities that are, or are required to be, additional insureds.
- The policy shall not contain a Contractors' Warranty or other similar language which eliminates or restricts insurance because of a subcontractor's failure to carry specific insurance or to supply evidence of such insurance.
- Required Evidence of Coverage:
 1. Copy of the additional insured endorsement or policy language granting additional insured status;
 2. Copy of the endorsement or policy language indicating that coverage applicable to the additional insureds is primary and non-contributory;
 3. Properly completed Certificate of Insurance; and
 4. Completed and signed Agent/Broker Questionnaire with supporting documentation as required.

C. Automobile Liability Insurance

- Minimum Limit: \$2,000,000 combined single limit per accident.
- Coverage shall apply to all owned, hired and non-owned vehicles.
- CITY shall qualify as an insured.
- Required Evidence of Coverage:
 1. Copy of the endorsement or policy language indicating that CITY is an insured; and
 2. Properly completed Certificate of Insurance.

D. Surety Bonds

- Bid bond.
- Performance and payment bonds for the entire contract price.
- The surety must be authorized to issue these bonds in the State of California.

E. Standards for Insurance Companies

- Insurers, other than the California State Compensation Insurance Fund, shall have an A.M. Best's rating of at least A:VII.

F. Documentation

- The Certificate of Insurance shall include the following reference:[City Project No. 2-R-22]
- The name and address for Additional Insured endorsements and Certificates of Insurance is: City of La Habra
- Contractor shall provide immediate written notice if: (1) any of the required

insurance policies is terminated; (2) the limits of any of the required policies are reduced; or (3) the deductible or self-insured retention is increased.

- Current Evidence of Coverage shall be provided for the entire required period of insurance.
- Upon written request, certified copies of required insurance policies shall be provided within thirty (30) days.

City Project No. 2-R-22.

EXHIBIT C

CERTIFICATES OF INSURANCE AND ENDORSEMENTS

BLANKET WAIVER OF OUR RIGHT TO RECOVER FROM OTHERS ENDORSEMENT

This endorsement changes the policy to which it is attached effective on the inception date of the policy unless a different date is indicated below.

(The following "attaching clause" need be completed only when this endorsement is issued subsequent to preparation of the policy).

This endorsement, effective 07/01/2023 12:01 AM forms a part of Policy No. WC 034284262 CA

Issued to

ADP TotalSource DE IV, Inc.
5800 Windward Parkway
Alpharetta, GA 30005
L/C/F:
GENTRY BROTHERS INC

384 Live Oak Ave
Irwindale, CA 91706

By AIU Insurance Company

We have a right to recover our payments from anyone liable for an injury covered by this policy. We will not enforce our right against any person or organization with whom you have a written contract that requires you to obtain this agreement from us, as regards any work you perform for such person or organization.

The additional premium for this endorsement shall be ___% of the total estimated workers compensation premium for this policy.

ANY PERSON OR ORGANIZATION TO WHOM YOU BECOME OBLIGATED TO WAIVE YOUR RIGHTS OF RECOVERY AGAINST, UNDER ANY CONTRACT OR AGREEMENT YOU ENTER INTO PRIOR TO THE OCCURRENCE OF LOSS

WC 04 03 61
(Ed. 11/90)

Countersigned by _____



Authorized Representative

SCHEDULE A - SCHEDULE OF UNDERLYING INSURANCE

| Carrier, Policy Number and Period | Type of Coverage | Limits of Insurance |
|--|---|---|
| a) AIU INSURANCE COMPANY POLICY: WC053449655 7/1/23 TO 7/1/24 | Employers Liability | Bodily Injury By Accident \$ 1,000,000. each accident Bodily Injury By Disease \$ 1,000,000. policy limit \$ 1,000,000. each employee |
| b) THE CONTINENTAL CASUALTY COMPANY POLICY: 7039560090 7/1/23 TO 7/1/24 | Automobile/Garage <input checked="" type="checkbox"/> Any Automobile <input type="checkbox"/> Owned Automobile Only <input type="checkbox"/> Specifically Designated Automobile <input type="checkbox"/> Hired Automobile <input type="checkbox"/> Non-owned Automobile <input type="checkbox"/> Garage Liability <input checked="" type="checkbox"/> DEFENSE OUTSIDE THE LIMIT | <input type="checkbox"/> Split Limit Bodily Injury Liability \$ each person \$ each accident Property Damage Liability \$ each accident <input checked="" type="checkbox"/> Combined Single Limit \$ 1,000,000. each accident <input type="checkbox"/> Garage Operations \$ Auto only each accident \$ Other than auto each accident \$ Other than auto aggregate |
| | <input type="checkbox"/> Garagekeepers Liability | \$ each location |

| Carrier, Policy Number and Period | Type of Coverage | Limits of Insurance |
|---|--|---|
| <p>c) ()</p> <p style="text-align: center;">OR</p> <p>(X) NATIONAL FIRE INSURANCE OF HARTFORD POLICY: 7039569078 7/1/23 TO 7/1/24</p> <p>(X) DEFENSE OUTSIDE THE LIMIT</p> <p>Retroactive Date</p> | <p>Comprehensive General Liability including</p> <p>() Products-Completed Operation Liability</p> <p>() Broad Form Endorsement</p> <p>()</p> <p>()</p> <p style="text-align: center;">OR</p> <p>Commercial General Liability</p> <p>(X) Occurrence Form</p> <p>() Claims-Made Form</p> <p>(X) GENERAL AGGREGATE APPLIES PER PROJECT</p> | <p>() Split Limit</p> <p>Bodily Injury Liability</p> <p>\$ each occurrence</p> <p>\$ aggregate</p> <p>Property Damage Liability</p> <p>\$ each occurrence</p> <p>\$ aggregate</p> <p>() Combined Single Limit</p> <p>\$ each occurrence</p> <p>\$ aggregate</p> <p style="text-align: center;">OR</p> <p>\$2,000,000. General Aggregate Limit</p> <p>\$2,000,000. Products-Completed Operation Aggregate Limit</p> <p>\$1,000,00. Personal and Advertising Injury Limit</p> <p>\$1,000,000. Each Occurrence Limit</p> |
| <p>d) NATIONAL FIRE INSURANCE OF HARTFORD POLICY: 7039569078 7/1/23 TO 7/1/24</p> | <p>EMPLOYEE BENEFIT LIABILITY</p> | <p>\$1,000,000. EACH EMPLOYEE</p> <p>\$1,000,000. AGGREGATE LIMIT</p> |

CONTRACTORS EXTENDED COVERAGE ENDORSEMENT - BUSINESS AUTO PLUS
THIS ENDORSEMENT CHANGES THE POLICY. PLEASE READ IT CAREFULLY.

This endorsement modifies insurance provided under the following:

BUSINESS AUTO COVERAGE FORM

I. LIABILITY COVERAGE
A. Who Is An Insured

The following is added to **Section II, Paragraph A.1., Who Is An Insured:**

1. **a.** Any incorporated entity of which the Named Insured owns a majority of the voting stock on the date of inception of this Coverage Form; provided that,
 - b.** The insurance afforded by this provision **A.1.** does not apply to any such entity that is an **insured** under any other liability "policy" providing **auto** coverage.
2. Any organization you newly acquire or form, other than a limited liability company, partnership or joint venture, and over which you maintain majority ownership interest.

The insurance afforded by this provision **A.2.:**

- a.** Is effective on the acquisition or formation date, and is afforded only until the end of the policy period of this Coverage Form, or the next anniversary of its inception date, whichever is earlier.
- b.** Does not apply to:
 - (1) **Bodily injury or property damage** caused by an **accident** that occurred before you acquired or formed the organization; or
 - (2) Any such organization that is an **insured** under any other liability "policy" providing **auto** coverage.
3. Any person or organization that you are required by a written contract to name as an additional insured is an **insured** but only with respect to their legal liability for acts or omissions of a person, who qualifies as an **insured** under **SECTION II – WHO IS AN INSURED** and for whom Liability Coverage is afforded under this policy. If required by written contract, this insurance will be primary and non-contributory to insurance on which the additional insured is a Named Insured.
4. An **employee** of yours is an **insured** while operating an **auto** hired or rented under a contract or agreement in that **employee's** name, with your permission, while performing duties related to the conduct of your business.

"Policy", as used in this provision **A. Who Is An Insured**, includes those policies that were in force on the inception date of this Coverage Form but:

1. Which are no longer in force; or
2. Whose limits have been exhausted.

B. Bail Bonds and Loss of Earnings

Section II, Paragraphs A.2. (2) and A.2. (4) are revised as follows:

1. In **a.(2)**, the limit for the cost of bail bonds is changed from \$2,000 to \$5,000; and
2. In **a.(4)**, the limit for the loss of earnings is changed from \$250 to \$500 a day.

Form No: CNA63359XX (04-2012)
 Endorsement Effective Date:
 Endorsement No: ; Page: 1 of 4
 Underwriting Company:

Endorsement Expiration Date:

Policy No:
 7039560090
 Policy Effective Date:
 07/01/2023
 Policy Page:



C. Fellow Employee

Section II, Paragraph B.5 does not apply.

Such coverage as is afforded by this provision C. is excess over any other collectible insurance.

II. PHYSICAL DAMAGE COVERAGE

A. Glass Breakage – Hitting A Bird Or Animal – Falling Objects Or Missiles

The following is added to **Section III, Paragraph A.3.:**

With respect to any covered **auto**, any deductible shown in the Declarations will not apply to glass breakage if such glass is repaired, in a manner acceptable to us, rather than replaced.

B. Transportation Expenses

Section III, Paragraph A.4.a. is revised, with respect to transportation expense incurred by you, to provide:

- a. \$60 per day, in lieu of \$20; subject to
- b. \$1,800 maximum, in lieu of \$600.

C. Loss of Use Expenses

Section III, Paragraph A.4.b. is revised, with respect to loss of use expenses incurred by you, to provide:

- a. \$1,000 maximum, in lieu of \$600.

D. Hired "Autos"

The following is added to **Section III. Paragraph A.:**

5. Hired "Autos"

If Physical Damage coverage is provided under this policy, and such coverage does not extend to Hired Autos, then Physical Damage coverage is extended to:

- a. Any covered **auto** you lease, hire, rent or borrow without a driver; and
- b. Any covered **auto** hired or rented by your **employee** without a driver, under a contract in that individual **employee's** name, with your permission, while performing duties related to the conduct of your business.
- c. The most we will pay for any one **accident** or **loss** is the actual cash value, cost of repair, cost of replacement or \$75,000, whichever is less, minus a \$500 deductible for each covered auto. No deductible applies to **loss** caused by fire or lightning.
- d. The physical damage coverage as is provided by this provision is equal to the physical damage coverage(s) provided on your owned **autos**.
- e. Such physical damage coverage for hired **autos** will:
 - (1) Include loss of use, provided it is the consequence of an **accident** for which the Named Insured is legally liable, and as a result of which a monetary loss is sustained by the leasing or rental concern.
 - (2) Such coverage as is provided by this provision will be subject to a limit of \$750 per **accident**.

E. Airbag Coverage

The following is added to **Section III, Paragraph B.3.:**

The accidental discharge of an airbag shall not be considered mechanical breakdown.

Form No: CNA63359XX (04-2012)
Endorsement Effective Date:
Endorsement No: ; Page: 2 of 4
Underwriting Company:

Endorsement Expiration Date:

Policy No:
7039560090
Policy Effective Date:
07/01/2023
Policy Page:



F. Electronic Equipment

Section III, Paragraphs B.4.c and B.4.d. are deleted and replaced by the following:

- c. Physical Damage Coverage on a covered **auto** also applies to **loss** to any permanently installed electronic equipment including its antennas and other accessories
- d. A \$100 per occurrence deductible applies to the coverage provided by this provision.

G. Diminution In Value

The following is added to **Section III, Paragraph B.6.:**

Subject to the following, the **diminution in value** exclusion does not apply to:

- a. Any covered **auto** of the private passenger type you lease, hire, rent or borrow, without a driver for a period of 30 days or less, while performing duties related to the conduct of your business; and
- b. Any covered **auto** of the private passenger type hired or rented by your **employee** without a driver for a period of 30 days or less, under a contract in that individual **employee's** name, with your permission, while performing duties related to the conduct of your business.
- c. Such coverage as is provided by this provision is limited to a **diminution in value** loss arising directly out of accidental damage and not as a result of the failure to make repairs; faulty or incomplete maintenance or repairs; or the installation of substandard parts.
- d. The most we will pay for **loss** to a covered **auto** in any one accident is the lesser of:
 - (1) \$5,000; or
 - (2) 20% of the **auto's** actual cash value (ACV).

III. Drive Other Car Coverage – Executive Officers

The following is added to **Sections II and III:**

- 1. Any **auto** you don't own, hire or borrow is a covered **auto** for Liability Coverage while being used by, and for Physical Damage Coverage while in the care, custody or control of, any of your "executive officers", except:
 - a. An **auto** owned by that "executive officer" or a member of that person's household; or
 - b. An **auto** used by that "executive officer" while working in a business of selling, servicing, repairing or parking **autos**.

Such Liability and/or Physical Damage Coverage as is afforded by this provision.

- (1) Equal to the greatest of those coverages afforded any covered **auto**; and
- (2) Excess over any other collectible insurance.

- 2. For purposes of this provision, "executive officer" means a person holding any of the officer positions created by your charter, constitution, by-laws or any other similar governing document, and, while a resident of the same household, includes that person's spouse.

Such "executive officers" are **insureds** while using a covered **auto** described in this provision.

IV. BUSINESS AUTO CONDITIONS

A. Duties In The Event Of Accident, Claim, Suit Or Loss

The following is added to **Section IV, Paragraph A.2.a.:**

Form No: CNA63359XX (04-2012)
Endorsement Effective Date:
Endorsement No: Page: 3 of 4
Underwriting Company:

Endorsement Expiration Date:

Policy No:
7039560090
Policy Effective Date:
07/01/2023
Policy Page:



- (4) Your **employees** may know of an **accident** or **loss**. This will not mean that you have such knowledge, unless such **accident** or **loss** is known to you or if you are not an individual, to any of your executive officers or partners or your insurance manager.

The following is added to **Section IV, Paragraph A.2.b.:**

- (6) Your **employees** may know of documents received concerning a claim or **suit**. This will not mean that you have such knowledge, unless receipt of such documents is known to you or if you are not an individual, to any of your executive officers or partners or your insurance manager.

B. Transfer Of Rights Of Recovery Against Others To Us

The following is added to **Section IV, Paragraph A.5. Transfer Of Rights Of Recovery Against Others To Us:**

We waive any right of recovery we may have, because of payments we make for injury or damage, against any person or organization for whom or which you are required by written contract or agreement to obtain this waiver from us.

This injury or damage must arise out of your activities under a contract with that person or organization.

You must agree to that requirement prior to an **accident** or **loss**.

C. Concealment, Misrepresentation or Fraud

The following is added to **Section IV, Paragraph B.2.:**

Your failure to disclose all hazards existing on the date of inception of this Coverage Form shall not prejudice you with respect to the coverage afforded provided such failure or omission is not intentional.

D. Other Insurance

The following is added to **Section IV, Paragraph B.5.:**

Regardless of the provisions of Paragraphs **5.a.** and **5.d.** above, the coverage provided by this policy shall be on a primary non-contributory basis. This provision is applicable only when required by a written contract.

That written contract must have been entered into prior to **Accident** or **Loss**.

E. Policy Period, Coverage Territory

Section IV, Paragraph B. 7.(5).(a). is revised to provide:

- a. 45 days of coverage in lieu of 30 days.

V. DEFINITIONS

Section V. paragraph C. is deleted and replaced by the following:

Bodily injury means bodily injury, sickness or disease sustained by a person, including mental anguish, mental injury or death resulting from any of these.

Form No: CNA63359XX (04-2012)
Endorsement Effective Date:
Endorsement No: Page: 4 of 4
Underwriting Company:

Endorsement Expiration Date:

Policy No:
7039560090
Policy Effective Date:
07/01/2023
Policy Page:



Contractors' General Liability Extension Endorsement

It is understood and agreed that this endorsement amends the **COMMERCIAL GENERAL LIABILITY COVERAGE PART** as follows. If any other endorsement attached to this policy amends any provision also amended by this endorsement, then that other endorsement controls with respect to such provision, and the changes made by this endorsement with respect to such provision do not apply.

TABLE OF CONTENTS

| |
|---|
| 1. Additional Insureds |
| 2. Additional Insured - Primary And Non-Contributory To Additional Insured's Insurance |
| 3. Bodily Injury – Expanded Definition |
| 4. Broad Knowledge of Occurrence/ Notice of Occurrence |
| 5. Broad Named Insured |
| 6. Broadened Liability Coverage For Damage To Your Product And Your Work |
| 7. Contractual Liability - Railroads |
| 8. Electronic Data Liability |
| 9. Estates, Legal Representatives and Spouses |
| 10. Expected Or Intended Injury – Exception for Reasonable Force |
| 11. General Aggregate Limits of Insurance – Per Project |
| 12. In Rem Actions |
| 13. Incidental Health Care Malpractice Coverage |
| 14. Joint Ventures/Partnership/Limited Liability Companies |
| 15. Legal Liability – Damage To Premises / Alienated Premises / Property In The Named Insured's Care, Custody or Control |
| 16. Liquor Liability |
| 17. Medical Payments |
| 18. Non-owned Aircraft Coverage |
| 19. Non-owned Watercraft |
| 20. Personal And Advertising Injury – Discrimination or Humiliation |
| 21. Personal And Advertising Injury - Contractual Liability |
| 22. Property Damage - Elevators |
| 23. Supplementary Payments |
| 24. Unintentional Failure To Disclose Hazards |
| 25. Waiver of Subrogation – Blanket |
| 26. Wrap-Up Extension: OCIP CCIP, or Consolidated (Wrap-Up) Insurance Programs |



Contractors' General Liability Extension Endorsement

1. ADDITIONAL INSUREDS

a. **WHO IS AN INSURED** is amended to include as an **Insured** any person or organization described in paragraphs **A.** through **H.** below whom a **Named Insured** is required to add as an additional insured on this **Coverage Part** under a written contract or written agreement, provided such contract or agreement:

(1) is currently in effect or becomes effective during the term of this **Coverage Part**; and

(2) was executed prior to:

(a) the **bodily injury** or **property damage**; or

(b) the offense that caused the **personal and advertising injury**,

for which such additional insured seeks coverage.

b. However, subject always to the terms and conditions of this policy, including the limits of insurance, the Insurer will not provide such additional insured with:

(1) a higher limit of insurance than required by such contract or agreement; or

(2) coverage broader than required by such contract or agreement, and in no event broader than that described by the applicable paragraph **A.** through **H.** below.

Any coverage granted by this endorsement shall apply only to the extent permissible by law.

A. Controlling Interest

Any person or organization with a controlling interest in a **Named Insured**, but only with respect to such person or organization's liability for **bodily injury**, **property damage** or **personal and advertising injury** arising out of:

1. such person or organization's financial control of a **Named Insured**; or

2. premises such person or organization owns, maintains or controls while a **Named Insured** leases or occupies such premises;

provided that the coverage granted by this paragraph does not apply to structural alterations, new construction or demolition operations performed by, on behalf of, or for such additional insured.

B. Co-owner of Insured Premises

A co-owner of a premises co-owned by a **Named Insured** and covered under this insurance but only with respect to such co-owner's liability for **bodily injury**, **property damage** or **personal and advertising injury** as co-owner of such premises.

C. Lessor of Equipment

Any person or organization from whom a **Named Insured** leases equipment, but only with respect to liability for **bodily injury**, **property damage** or **personal and advertising injury** caused, in whole or in part, by the **Named Insured's** maintenance, operation or use of such equipment, provided that the **occurrence** giving rise to such **bodily injury**, **property damage** or the offense giving rise to such **personal and advertising injury** takes place prior to the termination of such lease.

D. Lessor of Land

Any person or organization from whom a **Named Insured** leases land but only with respect to liability for **bodily injury**, **property damage** or **personal and advertising injury** arising out of the ownership, maintenance or use of such land, provided that the **occurrence** giving rise to such **bodily injury**, **property damage** or the offense giving rise to such **personal and advertising injury** takes place prior to the



Contractors' General Liability Extension Endorsement

termination of such lease. The coverage granted by this paragraph does not apply to structural alterations, new construction or demolition operations performed by, on behalf of, or for such additional insured.

E. Lessor of Premises

An owner or lessor of premises leased to the **Named Insured**, or such owner or lessor's real estate manager, but only with respect to liability for **bodily injury, property damage or personal and advertising injury** arising out of the ownership, maintenance or use of such part of the premises leased to the **Named Insured**, and provided that the **occurrence** giving rise to such **bodily injury or property damage**, or the offense giving rise to such **personal and advertising injury**, takes place prior to the termination of such lease. The coverage granted by this paragraph does not apply to structural alterations, new construction or demolition operations performed by, on behalf of, or for such additional insured.

F. Mortgagee, Assignee or Receiver

A mortgagee, assignee or receiver of premises but only with respect to such mortgagee, assignee or receiver's liability for **bodily injury, property damage or personal and advertising injury** arising out of the **Named Insured's** ownership, maintenance, or use of a premises by a **Named Insured**.

The coverage granted by this paragraph does not apply to structural alterations, new construction or demolition operations performed by, on behalf of, or for such additional insured.

G. State or Governmental Agency or Subdivision or Political Subdivisions – Permits

A state or governmental agency or subdivision or political subdivision that has issued a permit or authorization but only with respect to such state or governmental agency or subdivision or political subdivision's liability for **bodily injury, property damage or personal and advertising injury** arising out of:

1. the following hazards in connection with premises a **Named Insured** owns, rents, or controls and to which this insurance applies:
 - a. the existence, maintenance, repair, construction, erection, or removal of advertising signs, awnings, canopies, cellar entrances, coal holes, driveways, manholes, marquees, hoistaway openings, sidewalk vaults, street banners, or decorations and similar exposures; or
 - b. the construction, erection, or removal of elevators; or
 - c. the ownership, maintenance or use of any elevators covered by this insurance; or
2. the permitted or authorized operations performed by a **Named Insured** or on a **Named Insured's** behalf.

The coverage granted by this paragraph does not apply to:

- a. **Bodily injury, property damage or personal and advertising injury** arising out of operations performed for the state or governmental agency or subdivision or political subdivision; or
- b. **Bodily injury or property damage** included within the **products-completed operations hazard**.

With respect to this provision's requirement that additional insured status must be requested under a written contract or agreement, the Insurer will treat as a written contract any governmental permit that requires the **Named Insured** to add the governmental entity as an additional insured.

H. Trade Show Event Lessor

1. With respect to a **Named Insured's** participation in a trade show event as an exhibitor, presenter or displayer, any person or organization whom the **Named Insured** is required to include as an additional insured, but only with respect to such person or organization's liability for **bodily injury, property damage or personal and advertising injury** caused by:



Contractors' General Liability Extension Endorsement

- a. the **Named Insured's** acts or omissions; or
 - b. the acts or omissions of those acting on the **Named Insured's** behalf,
in the performance of the **Named Insured's** ongoing operations at the trade show event premises during the trade show event.
2. The coverage granted by this paragraph does not apply to **bodily injury** or **property damage** included within the **products-completed operations hazard**.

2. ADDITIONAL INSURED - PRIMARY AND NON-CONTRIBUTORY TO ADDITIONAL INSURED'S INSURANCE

The **Other Insurance** Condition in the **COMMERCIAL GENERAL LIABILITY CONDITIONS** Section is amended to add the following paragraph:

If the **Named Insured** has agreed in writing in a contract or agreement that this insurance is primary and non-contributory relative to an additional insured's own insurance, then this insurance is primary, and the Insurer will not seek contribution from that other insurance. For the purpose of this Provision **2.**, the additional insured's own insurance means insurance on which the additional insured is a named insured. Otherwise, and notwithstanding anything to the contrary elsewhere in this Condition, the insurance provided to such person or organization is excess of any other insurance available to such person or organization.

3. BODILY INJURY – EXPANDED DEFINITION

Under **DEFINITIONS**, the definition of **bodily injury** is deleted and replaced by the following:

Bodily injury means physical injury, sickness or disease sustained by a person, including death, humiliation, shock, mental anguish or mental injury sustained by that person at any time which results as a consequence of the physical injury, sickness or disease.

4. BROAD KNOWLEDGE OF OCCURRENCE/ NOTICE OF OCCURRENCE

Under **CONDITIONS**, the condition entitled **Duties in The Event of Occurrence, Offense, Claim or Suit** is amended to add the following provisions:

A. BROAD KNOWLEDGE OF OCCURRENCE

The **Named Insured** must give the Insurer or the Insurer's authorized representative notice of an **occurrence**, offense or **claim** only when the **occurrence**, offense or **claim** is known to a natural person **Named Insured**, to a partner, executive officer, manager or member of a **Named Insured**, or an **employee** designated by any of the above to give such notice.

B. NOTICE OF OCCURRENCE

The **Named Insured's** rights under this **Coverage Part** will not be prejudiced if the **Named Insured** fails to give the Insurer notice of an **occurrence**, offense or **claim** and that failure is solely due to the **Named Insured's** reasonable belief that the **bodily injury** or **property damage** is not covered under this **Coverage Part**. However, the **Named Insured** shall give written notice of such **occurrence**, offense or **claim** to the Insurer as soon as the **Named Insured** is aware that this insurance may apply to such **occurrence**, offense or **claim**.

5. BROAD NAMED INSURED

WHO IS AN INSURED is amended to delete its Paragraph **3.** in its entirety and replace it with the following:

3. Pursuant to the limitations described in Paragraph **4.** below, any organization in which a **Named Insured** has management control:
 - a. on the effective date of this **Coverage Part**; or



Contractors' General Liability Extension Endorsement

b. by reason of a **Named Insured** creating or acquiring the organization during the **policy period**,

qualifies as a **Named Insured**, provided that there is no other similar liability insurance, whether primary, contributory, excess, contingent or otherwise, which provides coverage to such organization, or which would have provided coverage but for the exhaustion of its limit, and without regard to whether its coverage is broader or narrower than that provided by this insurance.

But this **BROAD NAMED INSURED** provision does not apply to:

- (a) any partnership, limited liability company or joint venture; or
- (b) any organization for which coverage is excluded by another endorsement attached to this **Coverage Part**.

For the purpose of this provision, management control means:

- A. owning interests representing more than 50% of the voting, appointment or designation power for the selection of a majority of the Board of Directors of a corporation; or
- B. having the right, pursuant to a written trust agreement, to protect, control the use of, encumber or transfer or sell property held by a trust.

- 4. With respect to organizations which qualify as **Named Insureds** by virtue of Paragraph 3. above, this insurance does not apply to:
 - a. **bodily injury** or **property damage** that first occurred prior to the date of management control, or that first occurs after management control ceases; nor
 - b. **personal or advertising injury** caused by an offense that first occurred prior to the date of management control or that first occurs after management control ceases.
- 5. The insurance provided by this **Coverage Part** applies to **Named Insureds** when trading under their own names or under such other trading names or doing-business-as names (dba) as any **Named Insured** should choose to employ.

6. BROADENED LIABILITY COVERAGE FOR DAMAGE TO YOUR PRODUCT AND YOUR WORK

- A. Under **COVERAGES, Coverage A – Bodily Injury and Property Damage Liability**, the paragraph entitled **Exclusions** is amended to delete exclusions **k.** and **l.** and replace them with the following:

This insurance does not apply to:

k. Damage to Your Product

Property damage to your product arising out of it, or any part of it except when caused by or resulting from:

- (1) fire;
- (2) smoke;
- (3) collapse; or
- (4) explosion.

l. Damage to Your Work

Property damage to your work arising out of it, or any part of it and included in the **products-completed operations hazard**.

This exclusion does not apply:



Contractors' General Liability Extension Endorsement

- (1) If the damaged work, or the work out of which the damage arises, was performed on the **Named Insured's** behalf by a subcontractor; or
- (2) If the cause of loss to the damaged work arises as a result of:
 - (a) fire;
 - (b) smoke;
 - (c) collapse; or
 - (d) explosion.

B. The following paragraph is added to **LIMITS OF INSURANCE**:

Subject to **5.** above, \$100,000 is the most the Insurer will pay under **Coverage A** for the sum of **damages** arising out of any one **occurrence** because of **property damage to your product and your work** that is caused by fire, smoke, collapse or explosion and is included within the **product-completed operations hazard**. This sublimit does not apply to **property damage to your work** if the damaged work, or the work out of which the damage arises, was performed on the **Named Insured's** behalf by a subcontractor.

C. This **Broadened Liability Coverage For Damage To Your Product And Your Work** Provision does not apply if an endorsement of the same name is attached to this policy.

7. CONTRACTUAL LIABILITY – RAILROADS

With respect to operations performed within 50 feet of railroad property, the definition of **insured contract** is replaced by the following:

Insured Contract means:

- a. A contract for a lease of premises. However, that portion of the contract for a lease of premises that indemnifies any person or organization for damage by fire to premises while rented to a **Named Insured** or temporarily occupied by a **Named Insured** with permission of the owner is not an **insured contract**;
- b. A sidetrack agreement;
- c. Any easement or license agreement;
- d. An obligation, as required by ordinance, to indemnify a municipality, except in connection with work for a municipality;
- e. An elevator maintenance agreement;
- f. That part of any other contract or agreement pertaining to the **Named Insured's** business (including an indemnification of a municipality in connection with work performed for a municipality) under which the **Named Insured** assumes the tort liability of another party to pay for **bodily injury or property damage** to a third person or organization. Tort liability means a liability that would be imposed by law in the absence of any contract or agreement.

Paragraph **f.** does not include that part of any contract or agreement:

- (1) That indemnifies an architect, engineer or surveyor for injury or damage arising out of:
 - (a) Preparing, approving or failing to prepare or approve maps, shop drawings, opinions, reports, surveys, field orders, change orders or drawings and specifications; or
 - (b) Giving directions or instructions, or failing to give them, if that is the primary cause of the injury or damage;
- (2) Under which the **Insured**, if an architect, engineer or surveyor, assumes liability for an injury or damage arising out of the insured's rendering or failure to render professional services, including those listed in (1) above and supervisory, inspection, architectural or engineering activities.



Contractors' General Liability Extension Endorsement

8. ELECTRONIC DATA LIABILITY

- A. Under **COVERAGES, Coverage A – Bodily Injury and Property Damage Liability**, the paragraph entitled **Exclusions** is amended to delete exclusion **p. Electronic Data** and replace it with the following:

This insurance does not apply to:

p. Access Or Disclosure Of Confidential Or Personal Information And Data-related Liability

Damages arising out of:

- (1) any access to or disclosure of any person's or organization's confidential or personal information, including patents, trade secrets, processing methods, customer lists, financial information, credit card information, health information or any other type of nonpublic information; or
- (2) the loss of, loss of use of, damage to, corruption of, inability to access, or inability to manipulate **electronic data** that does not result from physical injury to tangible property.

However, unless Paragraph (1) above applies, this exclusion does not apply to **damages** because of **bodily injury**.

This exclusion applies even if damages are claimed for notification costs, credit monitoring expenses, forensic expenses, public relation expenses or any other loss, cost or expense incurred by the **Named Insured** or others arising out of that which is described in Paragraph (1) or (2) above.

- B. The following paragraph is added to **LIMITS OF INSURANCE**:

Subject to 5. above, \$100,000 is the most the Insurer will pay under **Coverage A** for all **damages** arising out of any one **occurrence** because of **property damage** that results from physical injury to tangible property and arises out of **electronic data**.

- C. The following definition is added to **DEFINITIONS**:

Electronic data means information, facts or programs stored as or on, created or used on, or transmitted to or from computer software (including systems and applications software), hard or floppy disks, CD-ROMS, tapes, drives, cells, data processing devices or any other media which are used with electronically controlled equipment.

- D. For the purpose of the coverage provided by this **ELECTRONIC DATA LIABILITY** Provision, the definition of **property damage** in **DEFINITIONS** is replaced by the following:

Property damage means:

- a. Physical injury to tangible property, including all resulting loss of use of that property. All such loss of use shall be deemed to occur at the time of the physical injury that caused it;
- b. Loss of use of tangible property that is not physically injured. All such loss of use shall be deemed to occur at the time of the **occurrence** that caused it; or
- c. Loss of, loss of use of, damage to, corruption of, inability to access, or inability to properly manipulate **electronic data**, resulting from physical injury to tangible property. All such loss of **electronic data** shall be deemed to occur at the time of the **occurrence** that caused it.

For the purposes of this insurance, **electronic data** is not tangible property.

- E. If Electronic Data Liability is provided at a higher limit by another endorsement attached to this policy, then the \$100,000 limit provided by this **ELECTRONIC DATA LIABILITY** Provision is part of, and not in addition to, that higher limit.

9. ESTATES, LEGAL REPRESENTATIVES, AND SPOUSES



Contractors' General Liability Extension Endorsement

The estates, heirs, legal representatives and **spouses** of any natural person **Insured** shall also be insured under this policy; provided, however, coverage is afforded to such estates, heirs, legal representatives, and **spouses** only for **claims** arising solely out of their capacity or status as such and, in the case of a **spouse**, where such **claim** seeks **damages** from marital community property, jointly held property or property transferred from such natural person **Insured** to such **spouse**. No coverage is provided for any act, error or omission of an estate, heir, legal representative, or **spouse** outside the scope of such person's capacity or status as such, provided however that the **spouse** of a natural person **Named Insured** and the **spouses** of members or partners of joint venture or partnership **Named Insureds** are **Insureds** with respect to such **spouses'** acts, errors or omissions in the conduct of the **Named Insured's** business.

10. EXPECTED OR INTENDED INJURY – EXCEPTION FOR REASONABLE FORCE

Under **COVERAGES, Coverage A – Bodily Injury and Property Damage Liability**, the paragraph entitled **Exclusions** is amended to delete the exclusion entitled **Expected or Intended Injury** and replace it with the following:

This insurance does not apply to:

Expected or Intended Injury

Bodily injury or **property damage** expected or intended from the standpoint of the **Insured**. This exclusion does not apply to **bodily injury** or **property damage** resulting from the use of reasonable force to protect persons or property.

11. GENERAL AGGREGATE LIMITS OF INSURANCE - PER PROJECT

A. For each construction project away from premises the **Named Insured** owns or rents, a separate Construction Project General Aggregate Limit, equal to the amount of the General Aggregate Limit shown in the Declarations, is the most the Insurer will pay for the sum of:

1. All **damages** under **Coverage A**, except **damages** because of **bodily injury** or **property damage** included in the **products-completed operations hazard**; and
2. All medical expenses under **Coverage C**,

that arise from **occurrences** or accidents which can be attributed solely to ongoing operations at that construction project. Such payments shall not reduce the General Aggregate Limit shown in the Declarations, nor the Construction Project General Aggregate Limit of any other construction project.

B. All:

1. **Damages** under **Coverage B**, regardless of the number of locations or construction projects involved;
2. **Damages** under **Coverage A**, caused by **occurrences** which cannot be attributed solely to ongoing operations at a single construction project, except **damages** because of **bodily injury** or **property damage** included in the **products-completed operations hazard**; and
3. Medical expenses under **Coverage C** caused by accidents which cannot be attributed solely to ongoing operations at a single construction project,

will reduce the General Aggregate Limit shown in the Declarations.

C. The limits shown in the Declarations for Each Occurrence, for Damage To Premises Rented To You and for Medical Expense continue to apply, but will be subject to either the Construction Project General Aggregate Limit or the General Aggregate Limit shown in the Declarations, depending on whether the **occurrence** can be attributed solely to ongoing operations at a particular construction project.

D. When coverage for liability arising out of the **products-completed operations hazard** is provided, any payments for **damages** because of **bodily injury** or **property damage** included in the **products-completed operations hazard** will reduce the Products-Completed Operations Aggregate Limit shown in the Declarations, regardless of the number of projects involved.



Contractors' General Liability Extension Endorsement

- E. If a single construction project away from premises owned by or rented to the **Insured** has been abandoned and then restarted, or if the authorized contracting parties deviate from plans, blueprints, designs, specifications or timetables, the project will still be deemed to be the same construction project.
- F. The provisions of **LIMITS OF INSURANCE** not otherwise modified by this endorsement shall continue to apply as stipulated.

12. IN REM ACTIONS

A quasi in rem action against any vessel owned or operated by or for the **Named Insured**, or chartered by or for the **Named Insured**, will be treated in the same manner as though the action were in personam against the **Named Insured**.

13. INCIDENTAL HEALTH CARE MALPRACTICE COVERAGE

Solely with respect to **bodily injury** that arises out of a **health care incident**:

- A. Under **COVERAGES, Coverage A – Bodily Injury and Property Damage Liability**, the paragraph entitled **Insuring Agreement** is amended to replace Paragraphs **1.b.(1)** and **1.b.(2)** with the following:
 - b. This insurance applies to **bodily injury** provided that the professional health care services are incidental to the **Named Insured's** primary business purpose, and only if:
 - (1) such **bodily injury** is caused by an **occurrence** that takes place in the **coverage territory**.
 - (2) the **bodily injury** first occurs during the **policy period**. All **bodily injury** arising from an **occurrence** will be deemed to have occurred at the time of the first act, error, or omission that is part of the **occurrence**; and
- B. Under **COVERAGES, Coverage A – Bodily Injury and Property Damage Liability**, the paragraph entitled **Exclusions** is amended to:
 - i. add the following to the **Employers Liability** exclusion:

This exclusion applies only if the **bodily injury** arising from a **health care incident** is covered by other liability insurance available to the **Insured** (or which would have been available but for exhaustion of its limits).
 - ii. delete the exclusion entitled **Contractual Liability** and replace it with the following:

This insurance does not apply to:

Contractual Liability

the **Insured's** actual or alleged liability under any oral or written contract or agreement, including but not limited to express warranties or guarantees.
 - iii. add the following additional exclusions:

This insurance does not apply to:

Discrimination

any actual or alleged discrimination, humiliation or harassment, including but not limited to **claims** based on an individual's race, creed, color, age, gender, national origin, religion, disability, marital status or sexual orientation.

Dishonesty or Crime

Any actual or alleged dishonest, criminal or malicious act, error or omission.

Medicare/Medicaid Fraud



Contractors' General Liability Extension Endorsement

any actual or alleged violation of law with respect to Medicare, Medicaid, Tricare or any similar federal, state or local governmental program.

Services Excluded by Endorsement

Any **health care incident** for which coverage is excluded by endorsement.

C. DEFINITIONS is amended to:

i. add the following definitions:

Health care incident means an act, error or omission by the **Named Insured's employees** or **volunteer workers** in the rendering of:

- a. **professional health care services** on behalf of the **Named Insured** or
- b. Good Samaritan services rendered in an emergency and for which no payment is demanded or received.

Professional health care services means any health care services or the related furnishing of food, beverages, medical supplies or appliances by the following providers in their capacity as such but solely to the extent they are duly licensed as required:

- a. Physician;
- b. Nurse;
- c. Nurse practitioner;
- d. Emergency medical technician;
- e. Paramedic;
- f. Dentist;
- g. Physical therapist;
- h. Psychologist;
- i. Speech therapist;
- j. Other allied health professional; or

Professional health care services does not include any services rendered in connection with human clinical trials or product testing.

ii. delete the definition of **occurrence** and replace it with the following:

Occurrence means a **health care incident**. All acts, errors or omissions that are logically connected by any common fact, circumstance, situation, transaction, event, advice or decision will be considered to constitute a single **occurrence**;

iii. amend the definition of **Insured** to:

a. add the following:

- the **Named Insured's employees** are **Insureds** with respect to:

- (1) **bodily injury** to a **co-employee** while in the course of the **co-employee's** employment by the **Named Insured** or while performing duties related to the conduct of the **Named Insured's** business; and



Contractors' General Liability Extension Endorsement

(2) **bodily injury** to a **volunteer worker** while performing duties related to the conduct of the **Named Insured's** business;

when such **bodily injury** arises out of a **health care incident**.

- the **Named Insured's volunteer workers** are **Insureds** with respect to:

(1) **bodily injury** to a **co-volunteer worker** while performing duties related to the conduct of the **Named Insured's** business; and

(2) **bodily injury** to an **employee** while in the course of the **employee's** employment by the **Named Insured** or while performing duties related to the conduct of the **Named Insured's** business;

when such **bodily injury** arises out of a **health care incident**.

- b. delete Subparagraphs (a), (b), (c) and (d) of Paragraph 2.a.(1) of **WHO IS AN INSURED**.

D. The **Other Insurance** condition is amended to delete Paragraph b.(1) in its entirety and replace it with the following:

Other Insurance

b. Excess Insurance

- (1) To the extent this insurance applies, it is excess over any other insurance, self insurance or risk transfer instrument, whether primary, excess, contingent or on any other basis, except for insurance purchased specifically by the **Named Insured** to be excess of this coverage.

14. JOINT VENTURES / PARTNERSHIP / LIMITED LIABILITY COMPANIES

WHO IS AN INSURED is amended to delete its last paragraph and replace it with the following:

No person or organization is an **Insured** with respect to the conduct of any current or past partnership, joint venture or limited liability company that is not shown as a **Named Insured** in the Declarations, except that if the **Named Insured** was a joint venturer, partner, or member of a limited liability company and such joint venture, partnership or limited liability company terminated prior to or during the **policy period**, such **Named Insured** is an **Insured** with respect to its interest in such joint venture, partnership or limited liability company but only to the extent that:

- a. any offense giving rise to **personal and advertising injury** occurred prior to such termination date, and the **personal and advertising injury** arising out of such offense first occurred after such termination date;
- b. the **bodily injury** or **property damage** first occurred after such termination date; and
- c. there is no other valid and collectible insurance purchased specifically to insure the partnership, joint venture or limited liability company; and

If the joint venture, partnership or limited liability company is or was insured under a **consolidated (wrap-up) insurance program**, then such insurance will always be considered valid and collectible for the purpose of paragraph c. above. But this provision will not serve to exclude **bodily injury**, **property damage** or **personal and advertising injury** that would otherwise be covered under the **Contractors General Liability Extension Endorsement** provision entitled **WRAP-UP EXTENSION: OCIP, CCIP, OR CONSOLIDATED (WRAP-UP) INSURANCE PROGRAMS**. Please see that provision for the definition of **consolidated (wrap-up) insurance program**.

15. LEGAL LIABILITY – DAMAGE TO PREMISES / ALIENATED PREMISES / PROPERTY IN THE NAMED INSURED'S CARE, CUSTODY OR CONTROL



Contractors' General Liability Extension Endorsement

- A. Under **COVERAGES, Coverage A – Bodily Injury and Property Damage Liability**, the paragraph entitled **Exclusions** is amended to delete exclusion **j. Damage to Property** in its entirety and replace it with the following:

This insurance does not apply to:

j. Damage to Property

Property damage to:

- (1) Property the **Named Insured** owns, rents, or occupies, including any costs or expenses incurred by you, or any other person, organization or entity, for repair, replacement, enhancement, restoration or maintenance of such property for any reason, including prevention of injury to a person or damage to another's property;
- (2) Premises the **Named Insured** sells, gives away or abandons, if the **property damage** arises out of any part of those premises;
- (3) Property loaned to the **Named Insured**;
- (4) Personal property in the care, custody or control of the **Insured**;
- (5) That particular part of real property on which the **Named Insured** or any contractors or subcontractors working directly or indirectly on the **Named Insured's** behalf are performing operations, if the **property damage** arises out of those operations; or
- (6) That particular part of any property that must be restored, repaired or replaced because **your work** was incorrectly performed on it.

Paragraphs (1), (3) and (4) of this exclusion do not apply to **property damage** (other than damage by fire) to premises rented to the **Named Insured** or temporarily occupied by the **Named Insured** with the permission of the owner, nor to the contents of premises rented to the **Named Insured** for a period of 7 or fewer consecutive days. A separate limit of insurance applies to Damage To Premises Rented To You as described in **LIMITS OF INSURANCE**.

Paragraph (2) of this exclusion does not apply if the premises are **your work**.

Paragraphs (3), (4), (5) and (6) of this exclusion do not apply to liability assumed under a sidetrack agreement.

Paragraph (6) of this exclusion does not apply to **property damage** included in the **products-completed operations hazard**.

Paragraphs (3) and (4) of this exclusion do not apply to **property damage** to:

- i. tools, or equipment the **Named Insured** borrows from others, nor
- ii. other personal property of others in the **Named Insured's** care, custody or control while being used in the **Named Insured's** operations away from any **Named Insured's** premises.

However, the coverage granted by this exception to Paragraphs (3) and (4) does not apply to:

- a. property at a job site awaiting or during such property's installation, fabrication, or erection;
- b. property that is **mobile equipment** leased by an **Insured**;
- c. property that is an **auto**, aircraft or watercraft;
- d. property in transit; or
- e. any portion of **property damage** for which the **Insured** has available other valid and collectible insurance, or would have such insurance but for exhaustion of its limits, or but for application of one of its exclusions.



Contractors' General Liability Extension Endorsement

A separate limit of insurance and deductible apply to such property of others. See **LIMITS OF INSURANCE** as amended below.

- B.** Under **COVERAGES, Coverage A – Bodily Injury and Property Damage Liability**, the paragraph entitled **Exclusions** is amended to delete its last paragraph and replace it with the following:

Exclusions **c.** through **n.** do not apply to damage by fire to premises while rented to a **Named Insured** or temporarily occupied by a **Named Insured** with permission of the owner, nor to damage to the contents of premises rented to a **Named Insured** for a period of 7 or fewer consecutive days.

A separate limit of insurance applies to this coverage as described in **LIMITS OF INSURANCE**.

- C.** The following paragraph is added to **LIMITS OF INSURANCE**:

Subject to **5.** above, \$25,000 is the most the Insurer will pay under **Coverage A** for **damages** arising out of any one **occurrence** because of the sum of all **property damage** to borrowed tools or equipment, and to other personal property of others in the **Named Insured's** care, custody or control, while being used in the **Named Insured's** operations away from any **Named Insured's** premises. The Insurer's obligation to pay such **property damage** does not apply until the amount of such **property damage** exceeds \$1,000. The Insurer has the right but not the duty to pay any portion of this \$1,000 in order to effect settlement. If the Insurer exercises that right, the **Named Insured** will promptly reimburse the Insurer for any such amount.

- D.** Paragraph **6.**, Damage To Premises Rented To You Limit, of **LIMITS OF INSURANCE** is deleted and replaced by the following:

6. Subject to Paragraph **5.** above, (the Each Occurrence Limit), the Damage To Premises Rented To You Limit is the most the Insurer will pay under **Coverage A** for **damages** because of **property damage** to any one premises while rented to the **Named Insured** or temporarily occupied by the **Named Insured** with the permission of the owner, including contents of such premises rented to the **Named Insured** for a period of 7 or fewer consecutive days. The Damage To Premises Rented To You Limit is the greater of:

- a.** \$500,000; or
- b.** The Damage To Premises Rented To You Limit shown in the Declarations.

- E.** Paragraph **4.b.(1)(a)(ii)** of the **Other Insurance** Condition is deleted and replaced by the following:

(ii) That is property insurance for premises rented to the **Named Insured**, for premises temporarily occupied by the **Named Insured** with the permission of the owner; or for personal property of others in the **Named Insured's** care, custody or control;

16. LIQUOR LIABILITY

Under **COVERAGES, Coverage A – Bodily Injury and Property Damage Liability**, the paragraph entitled **Exclusions** is amended to delete the exclusion entitled **Liquor Liability**.

This **LIQUOR LIABILITY** provision does not apply to any person or organization who otherwise qualifies as an additional insured on this **Coverage Part**.

17. MEDICAL PAYMENTS

- A.** **LIMITS OF INSURANCE** is amended to delete Paragraph **7.** (the Medical Expense Limit) and replace it with the following:

7. Subject to Paragraph **5.** above (the Each Occurrence Limit), the Medical Expense Limit is the most the Insurer will pay under **Coverage C – Medical Payments** for all medical expenses because of **bodily injury** sustained by any one person. The Medical Expense Limit is the greater of:

- (1)** \$15,000 unless a different amount is shown here: \$N,NNN,NNN,NNN; or



Contractors' General Liability Extension Endorsement

(2) the amount shown in the Declarations for Medical Expense Limit.

B. Under **COVERAGES**, the **Insuring Agreement of Coverage C – Medical Payments** is amended to replace Paragraph **1.a.(3)(b)** with the following:

(b) The expenses are incurred and reported to the Insurer within three years of the date of the accident; and

18. NON-OWNED AIRCRAFT

Under **COVERAGES, Coverage A – Bodily Injury and Property Damage Liability**, the paragraph entitled **Exclusions** is amended as follows:

The exclusion entitled **Aircraft, Auto or Watercraft** is amended to add the following:

This exclusion does not apply to an aircraft not owned by any **Named Insured**, provided that:

1. the pilot in command holds a currently effective certificate issued by the duly constituted authority of the United States of America or Canada, designating that person as a commercial or airline transport pilot;
2. the aircraft is rented with a trained, paid crew to the **Named Insured**; and
3. the aircraft is not being used to carry persons or property for a charge.

19. NON-OWNED WATERCRAFT

Under **COVERAGES, Coverage A – Bodily Injury and Property Damage Liability**, the paragraph entitled **Exclusions** is amended to delete subparagraph (2) of the exclusion entitled **Aircraft, Auto or Watercraft**, and replace it with the following.

This exclusion does not apply to:

(2) a watercraft that is not owned by any **Named Insured**, provided the watercraft is:

- (a) less than 75 feet long; and
- (b) not being used to carry persons or property for a charge.

20. PERSONAL AND ADVERTISING INJURY –DISCRIMINATION OR HUMILIATION

A. Under **DEFINITIONS**, the definition of **personal and advertising injury** is amended to add the following tort:

- Discrimination or humiliation that results in injury to the feelings or reputation of a natural person.

B. Under **COVERAGES, Coverage B – Personal and Advertising Injury Liability**, the paragraph entitled **Exclusions** is amended to:

1. delete the Exclusion entitled **Knowing Violation Of Rights Of Another** and replace it with the following:

This insurance does not apply to:

Knowing Violation of Rights of Another

Personal and advertising injury caused by or at the direction of the **Insured** with the knowledge that the act would violate the rights of another and would inflict **personal and advertising injury**. This exclusion shall not apply to discrimination or humiliation that results in injury to the feelings or reputation of a natural person, but only if such discrimination or humiliation is not done intentionally by or at the direction of:

- (a) the **Named Insured**; or



Contractors' General Liability Extension Endorsement

(b) any **executive officer**, director, stockholder, partner, member or manager (if the **Named Insured** is a limited liability company) of the **Named Insured**.

2. add the following exclusions:

This insurance does not apply to:

Employment Related Discrimination

Discrimination or humiliation directly or indirectly related to the employment, prospective employment, past employment or termination of employment of any person by any **Insured**.

Premises Related Discrimination

discrimination or humiliation arising out of the sale, rental, lease or sub-lease or prospective sale, rental, lease or sub-lease of any room, dwelling or premises by or at the direction of any **Insured**.

Notwithstanding the above, there is no coverage for fines or penalties levied or imposed by a governmental entity because of discrimination.

The coverage provided by this **PERSONAL AND ADVERTISING INJURY –DISCRIMINATION OR HUMILIATION** Provision does not apply to any person or organization whose status as an **Insured** derives solely from

- Provision 1. **ADDITIONAL INSURED** of this endorsement; or
- attachment of an additional insured endorsement to this **Coverage Part**.

This **PERSONAL AND ADVERTISING INJURY –DISCRIMINATION OR HUMILIATION** Provision does not apply to any person or organization who otherwise qualifies as an additional insured on this **Coverage Part**.

21. PERSONAL AND ADVERTISING INJURY - CONTRACTUAL LIABILITY

A. Under **COVERAGES**, **Coverage B –Personal and Advertising Injury Liability**, the paragraph entitled **Exclusions** is amended to delete the exclusion entitled **Contractual Liability**.

B. Solely for the purpose of the coverage provided by this **PERSONAL AND ADVERTISING INJURY - CONTRACTUAL LIABILITY** provision, the following changes are made to the section entitled **SUPPLEMENTARY PAYMENTS – COVERAGES A AND B**:

1. Paragraph **2.d.** is replaced by the following:

d. The allegations in the **suit** and the information the Insurer knows about the offense alleged in such **suit** are such that no conflict appears to exist between the interests of the **Insured** and the interests of the indemnitee;

2. The first unnumbered paragraph beneath Paragraph **2.f.(2)(b)** is deleted and replaced by the following:

So long as the above conditions are met, attorneys fees incurred by the Insurer in the defense of that indemnitee, necessary litigation expenses incurred by the Insurer, and necessary litigation expenses incurred by the indemnitee at the Insurer's request will be paid as **defense costs**. Such payments will not be deemed to be **damages** for **personal and advertising injury** and will not reduce the limits of insurance.

C. This **PERSONAL AND ADVERTISING INJURY - CONTRACTUAL LIABILITY** Provision does not apply if **Coverage B –Personal and Advertising Injury Liability** is excluded by another endorsement attached to this **Coverage Part**.

This **PERSONAL AND ADVERTISING INJURY - CONTRACTUAL LIABILITY** Provision does not apply to any person or organization who otherwise qualifies as an additional insured on this **Coverage Part**.



Contractors' General Liability Extension Endorsement

22. PROPERTY DAMAGE – ELEVATORS

- A. Under **COVERAGES, Coverage A – Bodily Injury and Property Damage Liability**, the paragraph entitled **Exclusions** is amended such that the **Damage to Your Product** Exclusion and subparagraphs **(3), (4)** and **(6)** of the **Damage to Property** Exclusion do not apply to **property damage** that results from the use of elevators.
- B. Solely for the purpose of the coverage provided by this **PROPERTY DAMAGE – ELEVATORS** Provision, the **Other Insurance** conditions is amended to add the following paragraph:

This insurance is excess over any of the other insurance, whether primary, excess, contingent or on any other basis that is Property insurance covering property of others damaged from the use of elevators.

23. SUPPLEMENTARY PAYMENTS

The section entitled **SUPPLEMENTARY PAYMENTS – COVERAGES A AND B** is amended as follows:

- A. Paragraph **1.b.** is amended to delete the \$250 limit shown for the cost of bail bonds and replace it with a \$5,000. limit; and
- B. Paragraph **1.d.** is amended to delete the limit of \$250 shown for daily loss of earnings and replace it with a \$1,000. limit.

24. UNINTENTIONAL FAILURE TO DISCLOSE HAZARDS

If the **Named Insured** unintentionally fails to disclose all existing hazards at the inception date of the **Named Insured's Coverage Part**, the Insurer will not deny coverage under this **Coverage Part** because of such failure.

25. WAIVER OF SUBROGATION - BLANKET

Under **CONDITIONS**, the condition entitled **Transfer Of Rights Of Recovery Against Others To Us** is amended to add the following:

The Insurer waives any right of recovery the Insurer may have against any person or organization because of payments the Insurer makes for injury or damage arising out of:

1. the **Named Insured's** ongoing operations; or
2. **your work** included in the **products-completed operations hazard**.

However, this waiver applies only when the **Named Insured** has agreed in writing to waive such rights of recovery in a written contract or written agreement, and only if such contract or agreement:

1. is in effect or becomes effective during the term of this **Coverage Part**; and
2. was executed prior to the **bodily injury, property damage or personal and advertising injury** giving rise to the **claim**.

26. WRAP-UP EXTENSION: OCIP, CCIP, OR CONSOLIDATED (WRAP-UP) INSURANCE PROGRAMS

Note: The following provision does not apply to any public construction project in the state of Oklahoma, nor to any construction project in the state of Alaska, that is not permitted to be insured under a **consolidated (wrap-up) insurance program** by applicable state statute or regulation.

If the endorsement **EXCLUSION – CONSTRUCTION WRAP-UP** is attached to this policy, or another exclusionary endorsement pertaining to Owner Controlled Insurance Programs (O.C.I.P.) or Contractor Controlled Insurance Programs (C.C.I.P.) is attached, then the following changes apply:

- A. The following wording is added to the above-referenced endorsement:



Contractors' General Liability Extension Endorsement

With respect to a **consolidated (wrap-up) insurance program** project in which the **Named Insured** is or was involved, this exclusion does not apply to those sums the **Named Insured** become legally obligated to pay as **damages** because of:

1. **Bodily injury, property damage, or personal or advertising injury** that occurs during the **Named Insured's** ongoing operations at the project, or during such operations of anyone acting on the **Named Insured's** behalf; nor
2. **Bodily injury or property damage** included within the **products-completed operations hazard** that arises out of those portions of the project that are not **residential structures**.

B. Condition 4. Other Insurance is amended to add the following subparagraph **4.b.(1)(c)**:

This insurance is excess over:

- (c)** Any of the other insurance whether primary, excess, contingent or any other basis that is insurance available to the **Named Insured** as a result of the **Named Insured** being a participant in a **consolidated (wrap-up) insurance program**, but only as respects the **Named Insured's** involvement in that **consolidated (wrap-up) insurance program**.

C. DEFINITIONS is amended to add the following definitions:

Consolidated (wrap-up) insurance program means a construction, erection or demolition project for which the prime contractor/project manager or owner of the construction project has secured general liability insurance covering some or all of the contractors or subcontractors involved in the project, such as an Owner Controlled Insurance Program (O.C.I.P.) or Contractor Controlled Insurance Program (C.C.I.P.).

Residential structure means any structure where 30% or more of the square foot area is used or is intended to be used for human residency, including but not limited to:

1. single or multifamily housing, apartments, condominiums, townhouses, co-operatives or planned unit developments; and
2. the common areas and structures appurtenant to the structures in paragraph 1. (including pools, hot tubs, detached garages, guest houses or any similar structures).

However, when there is no individual ownership of units, **residential structure** does not include military housing, college/university housing or dormitories, long term care facilities, hotels or motels. **Residential structure** also does not include hospitals or prisons.

This **WRAP-UP EXTENSION: OCIP, CCIP, OR CONSOLIDATED (WRAP-UP) INSURANCE PROGRAMS** Provision does not apply to any person or organization who otherwise qualifies as an additional insured on this **Coverage Part**.

All other terms and conditions of the Policy remain unchanged.

This endorsement, which forms a part of and is for attachment to the Policy issued by the designated Insurers, takes effect on the effective date of said Policy at the hour stated in said Policy, unless another effective date is shown below, and expires concurrently with said Policy.

This page has been left blank intentionally.



Blanket Additional Insured - Owners, Lessees or Contractors - with Products-Completed Operations Coverage Endorsement

This endorsement modifies insurance provided under the following:

COMMERCIAL GENERAL LIABILITY COVERAGE PART

It is understood and agreed as follows:

- I. **WHO IS AN INSURED** is amended to include as an **Insured** any person or organization whom you are required by **written contract** to add as an additional insured on this **coverage part**, but only with respect to liability for **bodily injury, property damage or personal and advertising injury** caused in whole or in part by your acts or omissions, or the acts or omissions of those acting on your behalf:
 - A. in the performance of your ongoing operations subject to such **written contract**; or
 - B. in the performance of **your work** subject to such **written contract**, but only with respect to **bodily injury or property damage** included in the **products-completed operations hazard**, and only if:
 1. the **written contract** requires you to provide the additional insured such coverage; and
 2. this **coverage part** provides such coverage.
- II. But if the **written contract** requires:
 - A. additional insured coverage under the 11-85 edition, 10-93 edition, or 10-01 edition of CG2010, or under the 10-01 edition of CG2037; or
 - B. additional insured coverage with "arising out of" language; or
 - C. additional insured coverage to the greatest extent permissible by law;then paragraph I. above is deleted in its entirety and replaced by the following:

WHO IS AN INSURED is amended to include as an **Insured** any person or organization whom you are required by **written contract** to add as an additional insured on this **coverage part**, but only with respect to liability for **bodily injury, property damage or personal and advertising injury** arising out of **your work** that is subject to such **written contract**.
- III. Subject always to the terms and conditions of this policy, including the limits of insurance, the Insurer will not provide such additional insured with:
 - A. coverage broader than required by the **written contract**; or
 - B. a higher limit of insurance than required by the **written contract**.
- IV. The insurance granted by this endorsement to the additional insured does not apply to **bodily injury, property damage, or personal and advertising injury** arising out of:
 - A. the rendering of, or the failure to render, any professional architectural, engineering, or surveying services, including:
 1. the preparing, approving, or failing to prepare or approve maps, shop drawings, opinions, reports, surveys, field orders, change orders or drawings and specifications; and
 2. supervisory, inspection, architectural or engineering activities; or
 - B. any premises or work for which the additional insured is specifically listed as an additional insured on another endorsement attached to this **coverage part**.
- V. Under **COMMERCIAL GENERAL LIABILITY CONDITIONS**, the Condition entitled **Other Insurance** is amended to add the following, which supersedes any provision to the contrary in this Condition or elsewhere in this **coverage part**:

Primary and Noncontributory Insurance



Blanket Additional Insured - Owners, Lessees or Contractors - with Products-Completed Operations Coverage Endorsement

With respect to other insurance available to the additional insured under which the additional insured is a named insured, this insurance is primary to and will not seek contribution from such other insurance, provided that a **written contract** requires the insurance provided by this policy to be:

1. primary and non-contributing with other insurance available to the additional insured; or
2. primary and to not seek contribution from any other insurance available to the additional insured.

But except as specified above, this insurance will be excess of all other insurance available to the additional insured.

VI. Solely with respect to the insurance granted by this endorsement, the section entitled **COMMERCIAL GENERAL LIABILITY CONDITIONS** is amended as follows:

The Condition entitled **Duties In The Event of Occurrence, Offense, Claim or Suit** is amended with the addition of the following:

Any additional insured pursuant to this endorsement will as soon as practicable:

1. give the Insurer written notice of any **claim**, or any **occurrence** or offense which may result in a **claim**;
2. send the Insurer copies of all legal papers received, and otherwise cooperate with the Insurer in the investigation, defense, or settlement of the **claim**; and
3. make available any other insurance, and tender the defense and indemnity of any **claim** to any other insurer or self-insurer, whose policy or program applies to a loss that the Insurer covers under this **coverage part**. However, if the **written contract** requires this insurance to be primary and non-contributory, this paragraph 3. does not apply to insurance on which the additional insured is a named insured.

The Insurer has no duty to defend or indemnify an additional insured under this endorsement until the Insurer receives written notice of a **claim** from the additional insured.

VII. Solely with respect to the insurance granted by this endorsement, the section entitled **DEFINITIONS** is amended to add the following definition:

Written contract means a written contract or written agreement that requires you to make a person or organization an additional insured on this **coverage part**, provided the contract or agreement:

- A. is currently in effect or becomes effective during the term of this policy; and
- B. was executed prior to:
 1. the **bodily injury or property damage**; or
 2. the offense that caused the **personal and advertising injury**;for which the additional insured seeks coverage.

Any coverage granted by this endorsement shall apply solely to the extent permissible by law.

All other terms and conditions of the Policy remain unchanged.

This endorsement, which forms a part of and is for attachment to the Policy issued by the designated Insurers, takes effect on the effective date of said Policy at the hour stated in said Policy, unless another effective date is shown below, and expires concurrently with said Policy.

EXHIBIT D
CLAIMS PROCEDURE

SUMMARY OF PUBLIC CONTRACT CODE § 9204

The following procedure will apply to any claims by the Contractor on the City:

A “claim” is a separate demand on the City by a contractor on a public works project and sent by registered mail or certified mail with return receipt requested, for one or more of the following:

- A time extension, including relief from penalties for delay
- Payment by the City of money damages under the terms of the contract
- Payment of an amount that is disputed by the City

Initial Review

The claim must be supported by appropriate documentation. The City has 45 days within which to review the claim and provide the contractor with a written statement identifying the disputed and undisputed portions of the claim. If the City does not issue a written statement, the claim is deemed rejected in its entirety. The City will pay any undisputed portion of the claim within 60 days of issuing the statement.

Meet & Confer

If the contractor disputes the City’s written response, or if the City does not issue one, the contractor may request in writing an informal conference to meet and confer for possible settlement of the claim. The City will schedule the meet and confer conference within 30 days of this request and provide a written statement identifying the remaining disputed and undisputed portions of the claim within 10 business days of the meet and confer. The City will pay the undisputed portion within 60 days of issuing this statement.

Mediation

With respect to any disputed portion remaining after the meet and confer, the City and contractor will submit the matter to nonbinding mediation, agree to a mediator within 10 business days after issuing the written statement, and share mediation costs equally. If mediation is unsuccessful, then the terms of the public works agreement and applicable law will govern resolution of the dispute.

Miscellaneous Provisions

Amounts not paid by the City in a timely manner bear interest at 7% per annum. Subcontractors may submit claims via this procedure through the general contractor. The City and contractor may waive the requirement to mediate, but cannot otherwise waive these claim procedures.