



---

# **Whittier Boulevard Starbucks**

## **NOISE IMPACT ANALYSIS**

### **CITY OF LA HABRA**

PREPARED BY:

William A. Maddux  
bmaddux@urbanxroads.com  
(619) 778-1971

FEBRUARY 21, 2024



## TABLE OF CONTENTS

<b>TABLE OF CONTENTS</b> .....	<b>I</b>
<b>APPENDICES</b> .....	<b>I</b>
<b>LIST OF EXHIBITS</b> .....	<b>II</b>
<b>LIST OF TABLES</b> .....	<b>II</b>
<b>LIST OF ABBREVIATED TERMS</b> .....	<b>II</b>
<b>1 INTRODUCTION</b> .....	<b>1</b>
1.1 Site Location.....	1
1.2 Project Description.....	1
<b>2 FUNDAMENTALS</b> .....	<b>5</b>
2.1 Range of Noise .....	5
2.2 Noise Descriptors .....	6
2.3 Sound Propagation.....	6
2.4 Noise Control .....	7
2.5 Noise Barrier Attenuation.....	8
2.6 Land Use Compatibility With Noise .....	8
2.7 Community Response to Noise .....	8
2.8 Vibration .....	9
<b>3 REGULATORY SETTING</b> .....	<b>11</b>
3.1 State of California Noise Requirements.....	11
3.2 State of California Green Building Standards Code .....	11
3.4 Operational Noise Standards .....	11
<b>4 RECEIVER LOCATIONS</b> .....	<b>13</b>
<b>5 OPERATIONAL NOISE ANALYSIS</b> .....	<b>15</b>
5.1 Operational Noise Sources.....	15
5.2 Reference Noise Levels .....	15
5.3 CadnaA Noise Prediction Model .....	17
5.4 Project Operational Noise Levels.....	18
5.5 Project Operational Noise Level Compliance.....	19
<b>9 REFERENCES</b> .....	<b>21</b>
<b>10 CERTIFICATIONS</b> .....	<b>23</b>

## APPENDICES

- APPENDIX 3.1: CITY OF LA HABRA MUNICIPAL CODE**
- APPENDIX 5.1: DRIVE-THROUGH SPEAKER MANUFACTURERS TEST DATA**
- APPENDIX 5.2: HVAC MANUFACTURERS SPECIFICATIONS**
- APPENDIX 5.3: CADNAA OPERATIONAL NOISE MODEL INPUTS**

## LIST OF EXHIBITS

EXHIBIT 1-A: LOCATION MAP .....2  
 EXHIBIT 1-B: SITE PLAN .....3  
 EXHIBIT 2-A: TYPICAL NOISE LEVELS .....5  
 EXHIBIT 2-B: NOISE LEVEL INCREASE PERCEPTION .....9  
 EXHIBIT 2-C: TYPICAL LEVELS OF GROUND-BORNE VIBRATION .....10  
 EXHIBIT 6-A: RECEIVER LOCATIONS .....14  
 EXHIBIT 5-A: OPERATIONAL NOISE SOURCE LOCATIONS .....16

## LIST OF TABLES

TABLE 3-1: OPERATIONAL NOISE STANDARDS .....12  
 TABLE 5-1: REFERENCE NOISE LEVEL MEASUREMENTS .....15  
 TABLE 5-2: DAYTIME PROJECT OPERATIONAL NOISE LEVELS .....18  
 TABLE 5-3: NIGHTTIME PROJECT OPERATIONAL NOISE LEVELS .....19  
 TABLE 5-4: OPERATIONAL NOISE LEVEL COMPLIANCE .....19

## LIST OF ABBREVIATED TERMS

(1)	Reference
ANSI	American National Standards Institute
CEQA	California Environmental Quality Act
CNEL	Community Noise Equivalent Level
dba	A-weighted decibels
FHWA	Federal Highway Administration
INCE	Institute of Noise Control Engineering
$L_{eq}$	Equivalent continuous (average) sound level
$L_{max}$	Maximum level measured over the time interval
$L_{min}$	Minimum level measured over the time interval
mph	Miles per hour
Project	Whittier Boulevard Starbucks

# **1 INTRODUCTION**

This noise analysis has been completed to determine the noise impacts associated with the development of the proposed Whittier Boulevard Starbucks (“Project”). This noise study briefly describes the proposed Project, provides information regarding noise fundamentals, sets out the local regulatory setting, presents the study methods and procedures for noise analysis, and evaluates the future exterior noise environment.

## **1.1 SITE LOCATION**

The proposed Whittier Boulevard Starbucks Project is located at 541 E. Whittier Boulevard (APN: 303-10-32) in the City of La Habra, as shown on Exhibit 1-A.

## **1.2 PROJECT DESCRIPTION**

The proposed Project includes the development of 1,200 square-foot drive-thru restaurant. The Project site plan is shown on Exhibit 1-B.

The on-site Project-related noise sources are expected to include ventilation and air conditioning units, and a drive-through speaker system. This noise analysis is intended to describe noise level impacts associated with the expected typical operational activities at the Project site. To present a conservative approach, this report assumes the Project will operate 24-hours daily, seven days per week.

EXHIBIT 1-A: LOCATION MAP





*This page intentionally left blank*

## 2 FUNDAMENTALS

Noise is simply defined as "unwanted sound." Sound becomes unwanted when it interferes with normal activities, when it causes actual physical harm or when it has adverse effects on health. Noise is measured on a logarithmic scale of sound pressure level known as a decibel (dB). A-weighted decibels (dBA) approximate the subjective response of the human ear to broad frequency noise source by discriminating against very low and very high frequencies of the audible spectrum. They are adjusted to reflect only those frequencies which are audible to the human ear. Exhibit 2-A presents a summary of the typical noise levels and their subjective loudness and effects that are described in more detail below.

**EXHIBIT 2-A: TYPICAL NOISE LEVELS**

COMMON OUTDOOR ACTIVITIES	COMMON INDOOR ACTIVITIES	A - WEIGHTED SOUND LEVEL dBA	SUBJECTIVE LOUDNESS	EFFECTS OF NOISE
THRESHOLD OF PAIN		140	INTOLERABLE OR DEAFENING	HEARING LOSS
NEAR JET ENGINE		130		
		120		
JET FLY-OVER AT 300m (1000 ft)	ROCK BAND	110		
LOUD AUTO HORN		100	VERY NOISY	SPEECH INTERFERENCE
GAS LAWN MOWER AT 1m (3 ft)		90		
DIESEL TRUCK AT 15m (50 ft), at 80 km/hr (50 mph)	FOOD BLENDER AT 1m (3 ft)	80	LOUD	
NOISY URBAN AREA, DAYTIME	VACUUM CLEANER AT 3m (10 ft)	70		
HEAVY TRAFFIC AT 90m (300 ft)	NORMAL SPEECH AT 1m (3 ft)	60	MODERATE	SLEEP DISTURBANCE
QUIET URBAN DAYTIME	LARGE BUSINESS OFFICE	50		
QUIET URBAN NIGHTTIME	THEATER, LARGE CONFERENCE ROOM (BACKGROUND)	40	FAINT	NO EFFECT
QUIET SUBURBAN NIGHTTIME	LIBRARY	30		
QUIET RURAL NIGHTTIME	BEDROOM AT NIGHT, CONCERT HALL (BACKGROUND)	20		
	BROADCAST/RECORDING STUDIO	10		
LOWEST THRESHOLD OF HUMAN HEARING	LOWEST THRESHOLD OF HUMAN HEARING	0	VERY FAINT	

Source: Environmental Protection Agency Office of Noise Abatement and Control, Information on Levels of Environmental Noise Requisite to Protect Public Health and Welfare with an Adequate Margin of Safety (EPA/ONAC 550/9-74-004) March 1974.

### 2.1 RANGE OF NOISE

Since the range of intensities that the human ear can detect is so large, the scale frequently used to measure intensity is a scale based on multiples of 10, the logarithmic scale. The scale for measuring intensity is the decibel scale. Each interval of 10 decibels indicates a sound energy ten times greater than before, which is perceived by the human ear as being roughly twice as loud. (2) The most common sounds vary between 40 dBA (very quiet) to 100 dBA (very loud). Normal conversation at three feet is roughly at 60 dBA, while loud jet engine noises equate to 110 dBA

at approximately 100 feet, which can cause serious discomfort. (3) Another important aspect of noise is the duration of the sound and the way it is described and distributed in time.

## 2.2 NOISE DESCRIPTORS

Environmental noise descriptors are generally based on averages, rather than instantaneous, noise levels. The most used figure is the equivalent level ( $L_{eq}$ ). Equivalent sound levels are not measured directly but are calculated from sound pressure levels typically measured in A-weighted decibels (dBA). The equivalent sound level ( $L_{eq}$ ) represents a steady state sound level containing the same total energy as a time varying signal over a given sample period (typically one hour) and is commonly used to describe the “average” noise levels within the environment.

To describe the time-varying character of environmental noise, the City of La Habra relies on the  $L_{25}$ ,  $L_{17}$ ,  $L_8$  and  $L_{max}$ , percentile noise levels to describe the stationary source noise level limits. The percentile noise descriptors are the noise levels equaled or exceeded during 25 percent, 17 percent, and 8 percent of a stated time. Sound levels associated with the  $L_8$  typically describe transient or short-term events, while levels associated with the  $L_{25}$  describe the base or typical noise conditions. The City of La Habra relies on the percentile noise levels to describe the stationary source noise level limits. While the  $L_{25}$  describes the noise levels occurring 25 percent of the time, the  $L_{eq}$  accounts for the total energy (average) observed for the entire hour.

Peak hour or average noise levels, while useful, do not completely describe a given noise environment, however. Noise levels lower than peak hour may be disturbing if they occur during times when quiet is most desirable, namely evening and nighttime (sleeping) hours. To account for this, the Community Noise Equivalent Level (CNEL), representing a composite 24-hour noise level is utilized. The CNEL is the weighted average of the intensity of a sound, with corrections for time of day, and averaged over 24 hours. The time of day corrections require the addition of 5 decibels to dBA  $L_{eq}$  sound levels in the evening from 7:00 p.m. to 10:00 p.m., and the addition of 10 decibels to dBA  $L_{eq}$  sound levels at night between 10:00 p.m. and 7:00 a.m. These additions are made to account for the noise sensitive time periods during the evening and night hours when sound appears louder. CNEL does not represent the actual sound level heard at any time, but rather represents the total sound exposure. The City of La Habra relies on the 24-hour CNEL level to assess land use compatibility with transportation related noise sources.

## 2.3 SOUND PROPAGATION

When sound propagates over a distance, it changes in level and frequency content. The way noise reduces with distance depends on the following factors.

### 2.3.1 GEOMETRIC SPREADING

Sound from a localized source (i.e., a stationary point source) propagates uniformly outward in a spherical pattern. The sound level attenuates (or decreases) at a rate of 6 dB for each doubling of distance from a point source. Highways consist of several localized noise sources on a defined path and hence can be treated as a line source, which approximates the effect of several point sources. Noise from a line source propagates outward in a cylindrical pattern, often referred to

as cylindrical spreading. Sound levels attenuate at a rate of 3 dB for each doubling of distance from a line source. (2)

### **2.3.2 GROUND ABSORPTION**

The propagation path of noise from a highway to a receiver is usually very close to the ground. Noise attenuation from ground absorption and reflective wave canceling adds to the attenuation associated with geometric spreading. Traditionally, the excess attenuation has also been expressed in terms of attenuation per doubling of distance. This approximation is usually sufficiently accurate for distances of less than 200 ft. For acoustically hard sites (i.e., sites with a reflective surface between the source and the receiver, such as a parking lot or body of water), no excess ground attenuation is assumed. For acoustically absorptive or soft sites (i.e., those sites with an absorptive ground surface between the source and the receiver such as soft dirt, grass, or scattered bushes and trees), an excess ground attenuation value of 1.5 dB per doubling of distance is normally assumed. When added to the cylindrical spreading, the excess ground attenuation results in an overall drop-off rate of 4.5 dB per doubling of distance from a line source. (4)

### **2.3.3 ATMOSPHERIC EFFECTS**

Receivers located downwind from a source can be exposed to increased noise levels relative to calm conditions, whereas locations upwind can have lowered noise levels. Sound levels can be increased at large distances (e.g., more than 500 feet) due to atmospheric temperature inversion (i.e., increasing temperature with elevation). Other factors such as air temperature, humidity, and turbulence can also have significant effects. (2)

### **2.3.4 SHIELDING**

A large object or barrier in the path between a noise source and a receiver can substantially attenuate noise levels at the receiver. The amount of attenuation provided by shielding depends on the size of the object and the frequency content of the noise source. Shielding by trees and other such vegetation typically only has an “out of sight, out of mind” effect. That is, the perception of noise impact tends to decrease when vegetation blocks the line-of-sight to nearby residents. However, for vegetation to provide a substantial, or even noticeable, noise reduction, the vegetation area must be at least 15 feet in height, 100 feet wide and dense enough to completely obstruct the line-of sight between the source and the receiver. This size of vegetation may provide up to 5 dBA of noise reduction. The Federal Highway Administration (FHWA) does not consider the planting of vegetation to be a noise abatement measure. (4)

## **2.4 NOISE CONTROL**

Noise control is the process of obtaining an acceptable noise environment for an observation point or receiver by controlling the noise source, transmission path, receiver, or all three. This concept is known as the source-path-receiver concept. In general, noise control measures can be applied to these three elements.

## 2.5 NOISE BARRIER ATTENUATION

Effective noise barriers can reduce noise levels by up to 10 to 15 dBA, cutting the loudness of traffic noise in half. A noise barrier is most effective when placed close to the noise source or receiver. Noise barriers, however, do have limitations. For a noise barrier to work, it must be high enough and long enough to block the path of the noise source. (4)

## 2.6 LAND USE COMPATIBILITY WITH NOISE

Some land uses are more tolerant of noise than others. For example, schools, hospitals, churches, and residences are more sensitive to noise intrusion than are commercial or industrial developments and related activities. As ambient noise levels affect the perceived amenity or livability of a development, so too can the mismanagement of noise impacts impair the economic health and growth potential of a community by reducing the area's desirability as a place to live, shop and work. For this reason, land use compatibility with the noise environment is an important consideration in the planning and design process. The FHWA encourages State and Local government to regulate land development in such a way that noise-sensitive land uses are either prohibited from being located adjacent to a highway, or that the developments are planned, designed, and constructed in such a way that noise impacts are minimized. (5)

## 2.7 COMMUNITY RESPONSE TO NOISE

Community responses to noise may range from registering a complaint by telephone or letter, to initiating court action, depending upon everyone's susceptibility to noise and personal attitudes about noise. Several factors are related to the level of community annoyance including:

- Fear associated with noise producing activities;
- Socio-economic status and educational level;
- Perception that those affected are being unfairly treated;
- Attitudes regarding the usefulness of the noise-producing activity;
- Belief that the noise source can be controlled.

Approximately ten percent of the population has a very low tolerance for noise and will object to any noise not of their making. Consequently, even in the quietest environment, some complaints will occur. Twenty-five percent of the population will not complain even in very severe noise environments. Thus, a variety of reactions can be expected from people exposed to any given noise environment. (6) Surveys have shown that about ten percent of the people exposed to traffic noise of 60 dBA will report being highly annoyed with the noise, and each increase of one dBA is associated with approximately two percent more people being highly annoyed. When traffic noise exceeds 60 dBA or aircraft noise exceeds 55 dBA, people may begin to complain. (6) Despite this variability in behavior on an individual level, the population can be expected to exhibit the following responses to changes in noise levels as shown on Exhibit 2-B. A change of 3 dBA are considered *barely perceptible*, and changes of 5 dBA are considered *readily perceptible*. (4)

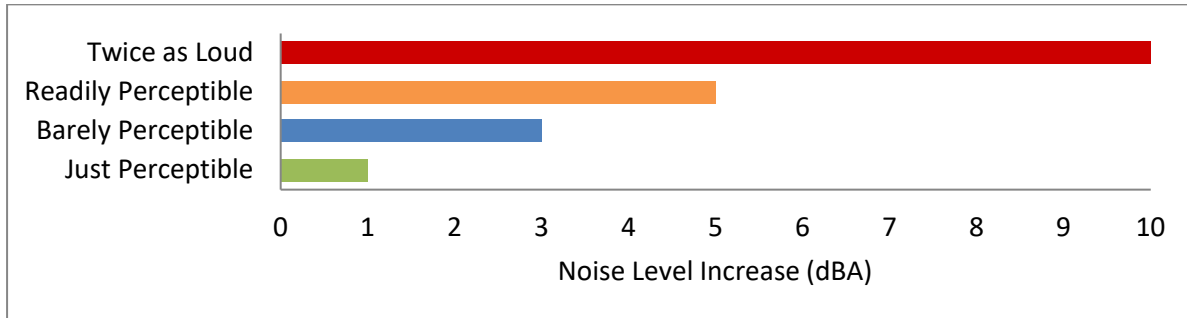
**EXHIBIT 2-B: NOISE LEVEL INCREASE PERCEPTION****2.8 VIBRATION**

Per the Federal Transit Administration (FTA) *Transit Noise and Vibration Impact Assessment Manual*, vibration is the periodic oscillation of a medium or object. The rumbling sound caused by the vibration of room surfaces is called structure-borne noise. Sources of ground-borne vibrations include natural phenomena (e.g., earthquakes, volcanic eruptions, sea waves, landslides) or human-made causes (e.g., explosions, machinery, traffic, trains, construction equipment). Vibration sources may be continuous, such as factory machinery, or transient, such as explosions. As is the case with airborne sound, ground-borne vibrations may be described by amplitude and frequency.

Additionally, in contrast to airborne noise, ground-borne vibration outdoors is not a common environmental problem and annoyance from ground-borne vibration is almost exclusively an indoor phenomenon (7). Therefore, the effects of vibrations should only be evaluated at a structure and the effects of the building structure on the vibration should be considered. Wood-frame buildings, such as typical residential structures, are more easily excited by ground vibration than heavier buildings. In contrast, large masonry buildings with spread footings have a low response to ground vibration (7). In general, the heavier a building is, the lower the response will be to the incident vibration energy. However, all structures reduce vibration levels due to the coupling of the building to the soil.

There are several different methods that are used to quantify vibration. The peak particle velocity (PPV) is defined as the maximum instantaneous peak of the vibration signal (7). The PPV is most frequently used to describe vibration impacts to buildings but is not always suitable for evaluating human response (annoyance) because it takes some time for the human body to respond to vibration signals. Instead, the human body responds to average vibration amplitude often described as the root mean square (RMS). The RMS amplitude is defined as the average of the squared amplitude of the signal and is most frequently used to describe the effect of vibration on the human body (7). However, the RMS amplitude and PPV are related mathematically, and the RMS amplitude of equipment is typically calculated from the PPV reference level. The RMS amplitude is approximately 70% of the PPV (8). Thus, either can be used on the description of vibration impacts.

While not universally accepted, vibration decibel notation (VdB) is another vibration notation developed and used by the FTA in their guidance manual to describe vibration levels and provide

a background of common vibration levels and set vibration limits (9). Decibel notation (VdB) serves to reduce the range of numbers used to describe vibration levels and is used in this report to describe vibration levels.

As stated in the FTA guidance manual, the background vibration-velocity level in residential areas is generally 50 VdB. Ground-borne vibration is normally perceptible to humans at approximately 65 VdB. For most people, a vibration-velocity level of 75 VdB is the approximate dividing line between barely perceptible and distinctly perceptible levels. Typical outdoor sources of perceptible ground-borne vibration are construction equipment, steel-wheeled trains, and traffic on rough roads. If a roadway is smooth, the ground-borne vibration is rarely perceptible. The range of interest is from approximately 50 VdB, which is the typical background vibration-velocity level, to 100 VdB, which is the general threshold where minor damage can occur in fragile buildings. Exhibit 2-C illustrates common vibration sources and the human and structural response to ground-borne vibration.

**EXHIBIT 2-C: TYPICAL LEVELS OF GROUND-BORNE VIBRATION**

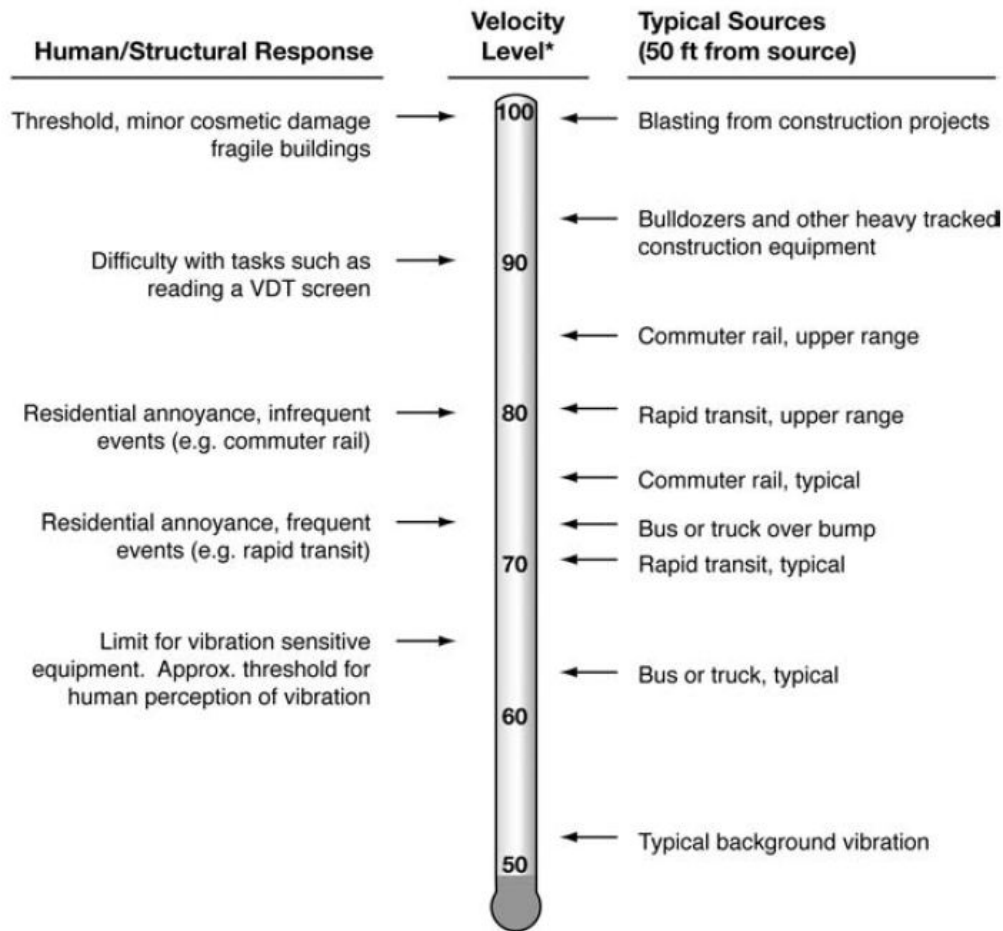

\* RMS Vibration Velocity Level in VdB relative to 10<sup>-6</sup> inches/second

Source: Federal Transit Administration (FTA) Transit Noise and Vibration Impact Assessment Manual.

### 3 REGULATORY SETTING

To limit population exposure to physically and/or psychologically damaging as well as intrusive noise levels, the federal government, the State of California, various county governments, and most municipalities in the state have established standards and ordinances to control noise. In most areas, automobile and truck traffic is the major source of environmental noise. Traffic activity generally produces an average sound level that remains constant with time. Air and rail traffic, and commercial and industrial activities are also major sources of noise in some areas. Federal, state, and local agencies regulate different aspects of environmental noise. Federal and state agencies generally set noise standards for mobile sources such as aircraft and motor vehicles, while regulation of stationary sources is left to local agencies.

#### 3.1 STATE OF CALIFORNIA NOISE REQUIREMENTS

The State of California regulates freeway noise, sets standards for sound transmission, provides occupational noise control criteria, identifies noise standards, and provides guidance for local land use compatibility. State law requires that each county and city adopt a General Plan that includes a Noise Element which is to be prepared per guidelines adopted by the Governor's Office of Planning and Research (OPR). (10) The purpose of the Noise Element is to *limit the exposure of the community to excessive noise levels*. In addition, the California Environmental Quality Act (CEQA) requires that all known environmental effects of a project be analyzed, including environmental noise impacts.

#### 3.2 STATE OF CALIFORNIA GREEN BUILDING STANDARDS CODE

The State of California's noise insulation standards are codified in the California Code of Regulations, Title 24, Building Standards Administrative Code, Part 2, and the California Building Code. These noise standards are applied to new construction in California for controlling interior noise levels resulting from exterior noise sources. The regulations specify that acoustical studies must be prepared when noise-sensitive structures, such as residential buildings, schools, or hospitals, are developed near major transportation noise sources, and where such noise sources create an exterior noise level of 60 dBA CNEL or higher. Acoustical studies that accompany building plans for noise-sensitive land uses must demonstrate that the structure has been designed to limit interior noise in habitable rooms to acceptable noise levels. For new residential

#### 3.4 OPERATIONAL NOISE STANDARDS

To analyze noise impacts originating from a designated fixed location or private property such as the Whittier Boulevard Starbucks Project, stationary-source (operational) noise such as the expected ventilation and air conditioning units, and a drive-through speaker system are typically evaluated against standards established under a City's Municipal Code. The City of La Habra Municipal Code, Chapter 9.32 *Noise Control*, Section 9.32.050 establishes the permissible noise level that may be received on property occupied by another person for residential land uses. For noise-sensitive residential properties, the exterior noise level shall not exceed 55 dBA  $L_{eq}$  during daytime hours (7:00 a.m. to 10:00 p.m.) and shall not exceed 50 dBA  $L_{eq}$  during the nighttime

hours (10:00 p.m. to 7:00 a.m.), as defined by the Municipal Code. (11) Further, the standard plus 5 dBA cannot be exceeded for a cumulative period of more than 15 minutes ( $L_{25}$ ) in any hour, or the standard plus 10 dBA for a cumulative period of more than 5 minutes ( $L_8$ ) in any hour, or the standard plus 20 dBA at any time ( $L_{max}$ ). The City of La Habra Municipal Code noise limits are shown on Table 3-1 and included in Appendix 3.1.

**TABLE 3-1: OPERATIONAL NOISE STANDARDS**

Jurisdiction	Noise Zone	Time Period	Exterior Noise Levels (dBA) <sup>2</sup>			
			Leq (Energy Avg.)	L <sub>25</sub> (15 mins)	L <sub>8</sub> (5 mins)	L <sub>max</sub> (Anytime)
City of La Habra	1	Daytime	55	60	65	75
		Nighttime	50	55	60	70

<sup>1</sup> Section 9.32.050 of the City of La Habra Municipal Code (Appendix 3.1).

<sup>2</sup> Leq represents a steady state sound level containing the same total energy as a time varying signal over a given sample period. The percent noise level is the level exceeded "n" percent of the time during the measurement period. L<sub>25</sub> is the noise level exceeded 25% of the time.

"Daytime" = 7:00 a.m. to 9:00 p.m.; "Nighttime" = 9:00 p.m. to 7:00 a.m.

## 4 RECEIVER LOCATIONS

To assess the potential for long-term operational noise impacts, the following sensitive receiver locations, as shown on Exhibit 4-A, were identified as representative locations for analysis. Sensitive receivers are generally defined as locations where people reside or where the presence of unwanted sound could otherwise adversely affect the use of the land. Noise-sensitive land uses are generally considered to include schools, hospitals, single-family dwellings, mobile home parks, churches, libraries, and recreation areas. Moderately noise-sensitive land uses typically include multi-family dwellings, hotels, motels, dormitories, out-patient clinics, cemeteries, golf courses, country clubs, athletic/tennis clubs, and equestrian clubs. Land uses that are considered relatively insensitive to noise include business, commercial, and professional developments. Land uses that are typically not affected by noise include: industrial, manufacturing, utilities, agriculture, undeveloped land, parking lots, warehousing, liquid and solid waste facilities, salvage yards, and transit terminals.

To describe the potential off-site Project noise levels, three receiver locations in the vicinity of the Project site were identified. All distances are measured from the Project site boundary to the outdoor living areas (e.g., private backyards) or at the building façade, whichever is closer to the Project site. The selection of receiver locations is based on FHWA guidelines and is consistent with additional guidance provided by Caltrans and the FTA, as previously described in Section 5.2. Other sensitive land uses in the Project study area that are located at greater distances than those identified in this noise study will experience lower noise levels than those presented in this report due to the additional attenuation from distance and the shielding of intervening structures. Distance is measured in a straight line from the project boundary to each receiver location.

- R1: Location R1 represents the existing noise sensitive residence at 829 Chestnut Street of the Project site. Receiver R1 is placed at the private outdoor living areas (backyards) facing the Project site.
- R2: Location R2 represents the existing noise sensitive residence at 820 Chestnut Street, northeast of the Project site. Since no private outdoor living areas face the Project site, Receiver R2 is placed at the nearest building façade facing the Project site.
- R3: Location R3 represents the existing noise sensitive residence at 761 Chestnut Street, south of the Project site. Receiver R3 is placed at the private outdoor living areas (backyards) facing the Project site.

EXHIBIT 4-A: RECEIVER LOCATIONS



**LEGEND:**  
N [North Arrow] [Red dashed box] Site Boundary [Black circle with crosshair] Receiver Locations

## 5 OPERATIONAL NOISE ANALYSIS

This section analyzes the potential stationary-source operational noise impacts at the nearest receiver locations, identified in Section 6, resulting from the operation of the proposed Whittier Boulevard Starbucks Project. Exhibit 5-A identifies the noise source locations used to assess the operational noise levels.

### 5.1 OPERATIONAL NOISE SOURCES

This operational noise analysis is intended to describe noise level impacts associated with the expected typical daytime and nighttime commercial activities at the Project site. To present the potential worst-case noise conditions, this analysis assumes the Project would be operational 24 hours per day, seven days per week. The on-site Project-related noise sources are expected to include: ventilation and air conditioning units, and a drive-through speaker system.

### 5.2 REFERENCE NOISE LEVELS

To estimate the Project operational noise impacts, reference noise level measurements were collected from similar types of activities to represent the noise levels expected with the development of the proposed Project. This section provides a detailed description of the reference noise level measurements shown on Table 5-1 used to estimate the Project operational noise impacts.

**TABLE 5-1: REFERENCE NOISE LEVEL MEASUREMENTS**

Noise Source	Noise Source Height (Feet)	Min./Hour <sup>1</sup>		Reference Noise Level (dBA <sub>Leq</sub> ) @ 50 Feet	Sound Power Level (dBA) <sup>2</sup>
		Day	Night		
YHD240G3RLD	3'	45	30	64.5	96.1
Drive-Through Speakers	2'	20	20	57.2	88.8

<sup>1</sup> Anticipated duration (minutes within the hour) of noise activity during typical hourly conditions expected at the Project site. "Daytime" = 7:00 a.m. to 9:00 p.m.; "Nighttime" = 9:00 p.m. to 7:00 a.m.

<sup>2</sup> Sound power level represents the total amount of acoustical energy (noise level) produced by a sound source independent of distance or surroundings. Sound power levels calculated using the CadnaA noise model at the reference distance to the noise source. Numbers may vary due to size differences between point and area noise sources.

EXHIBIT 5-A: OPERATIONAL NOISE SOURCE LOCATIONS



- LEGEND:**
- Site Boundary
  - Roof-Top Air Conditioning Unit
  - Existing Barrier
  - Receiver Locations
  - Drive-Through Speakerphone

### 5.2.1 DRIVE-THROUGH SPEAKER

The reference Project operational sound power level for the drive-through menu speaker is 88.8 dBA  $L_w$  based on the drive-through manufacturer's field and laboratory noise measurements (Appendix 5.1). This noise level is used to describe the worst-case reference noise levels at 100 percent operation. However, in practice, the speakers only operate for approximately 20 minutes of an hour when the operator is asking questions of the patron. It should be noted the speakers have a built in Automatic Volume Control (AVC), which are used to reduce the outbound sound pressure level based on ambient noise. The AVC effects can be calculated using the formula:

$$Attn = (NI + 14) - 72$$

where NI is the ambient noise level

Based on this equation, if the ambient noise level is 55 dBA  $L_{eq}$ , the AVC would reduce the speaker noise level by 3 dBA and if the ambient noise level is 50 dBA  $L_{eq}$ , the AVC would reduce the speaker noise level by 8 dBA. To be conservative the effects of the AVC are not accounted for in these calculations.

### 5.2.2 ROOF-TOP HEATING, VENTILATION, AND AIR CONDITIONING UNITS

The primary noise sources on-site would be the ventilation for the mechanical equipment used to heat and cool spaces. HVAC equipment associated with the Project is roof mounted and the noise sources are primarily the fans and compressors associated with the condenser units. Based on information provided for a similar facility in San Diego County, the Project would likely include a Trane YHC048F3RLA 4-ton HVAC unit. Based on manufactures specifications, a Trane YHC048F3RLA generates a sound power level of 87.2 dBA  $L_w$ . The HVAC units would be shielded from the ground by a 6-foot-high parapet wall located atop the building, which is accounted for in the noise modeling. HVAC manufactures specification sheets are provided in Appendix 5.2.

While operating at full power air conditioners would operate approximately 15-30 minutes out of an hour in multiple cycles during the nighttime as compared to the daytime where the units would typically operate 20-45 minutes in multiple cycles. To be conservative, it was assumed the air conditioners would operate 45 minutes during the daytime and 30 minutes at night. This is equivalent to the air conditioning units operating at full capacity. These sources of noise activity will likely vary throughout the day as well as the year.

## 5.3 CADNAA NOISE PREDICTION MODEL

To fully describe the exterior operational noise levels from the Project, Urban Crossroads, Inc. developed a noise prediction model using the CadnaA (Computer Aided Noise Abatement) computer program. CadnaA can analyze multiple types of noise sources using the spatially accurate Project site plan, georeferenced Nearmap aerial imagery, topography, buildings, and barriers in its calculations to predict outdoor noise levels.

Using the ISO 9613 protocol, CadnaA will calculate the distance from each noise source to the noise receiver locations, using the ground absorption, distance, and barrier/building attenuation

inputs to provide a summary of noise level at each receiver and the partial noise level contributions by noise source. Consistent with the ISO 9613 protocol, the CadnaA noise prediction model relies on the reference sound power level ( $L_w$ ) to describe individual noise sources. While sound pressure levels (e.g.  $L_{eq}$ ) quantify in decibels the intensity of given sound sources at a reference distance, sound power levels ( $L_w$ ) are connected to the sound source and are independent of distance. Sound pressure levels vary substantially with distance from the source and diminish from intervening obstacles and barriers, air absorption, wind, and other factors.

Sound power is the acoustical energy emitted by the sound source and is an absolute value that is not affected by the environment. The operational noise level calculations provided in this noise study account for the distance attenuation provided due to geometric spreading, when sound from a localized stationary source (i.e., a point source) propagates uniformly outward in a spherical pattern. A default ground attenuation factor of 0.5 was used in the CadnaA noise analysis to account for semi-hard site conditions. Appendix 5.3 includes the detailed noise model inputs.

#### 5.4 PROJECT OPERATIONAL NOISE LEVELS

Using the reference noise levels to represent the proposed Project operations that include ventilation and air conditioning units, and a drive-through speaker system, Urban Crossroads, Inc. calculated the operational source noise levels that are expected to be generated at the Project site and the Project-related noise level increases that would be experienced at each of the sensitive receiver locations. Table 5-2 shows the Project operational noise levels during the daytime hours of 7:00 a.m. to 10:00 p.m. The daytime hourly noise levels at the off-site receiver locations are expected to range from 38.7 to 48.8 dBA  $L_{eq}$ .

**TABLE 5-2: DAYTIME PROJECT OPERATIONAL NOISE LEVELS**

Noise Source <sup>1</sup>	Operational Noise Levels by Receiver Location (dBA $L_{max}$ )		
	R1	R2	R3
Air Conditioning Units	41.7	37.2	38.6
Drive-Through Speakers	47.9	34.9	23.7
<b>Total (All Noise Sources)</b>	<b>48.8</b>	<b>39.2</b>	<b>38.7</b>

<sup>1</sup> See Exhibit 5-A for the noise source locations. CadnaA noise model calculations are included in Appendix 5.1.

Table 5-3 shows the Project operational noise levels during the nighttime hours of 10:00 p.m. to 7:00 a.m. The nighttime hourly noise levels at the off-site receiver locations are expected to range from 36.0 to 47.6 dBA  $L_{eq}$ . The differences between the daytime and nighttime noise levels is largely related to the duration of noise activity (Table 5-1).

**TABLE 5-3: NIGHTTIME PROJECT OPERATIONAL NOISE LEVELS**

Noise Source <sup>1</sup>	Operational Noise Levels by Receiver Location (dBA L <sub>max</sub> )		
	R1	R2	R3
Air Conditioning Units	39.0	34.5	35.8
Drive-Through Speakers	46.9	33.9	22.7
<b>Total (All Noise Sources)</b>	<b>47.6</b>	<b>37.2</b>	<b>36.0</b>

<sup>1</sup> See Exhibit 5-A for the noise source locations. CadnaA noise model calculations are included in Appendix 5.1.

## 5.5 PROJECT OPERATIONAL NOISE LEVEL COMPLIANCE

To demonstrate compliance with local noise regulations, the Project-only operational noise levels are evaluated against exterior noise level thresholds based on the City of La Habra exterior noise level standards at nearest noise-sensitive receiver locations. Table 5-4 shows the operational noise levels associated with Whittier Boulevard Starbucks Project will satisfy the City of La Habra 55 dBA L<sub>eq</sub> daytime and 50 dBA L<sub>eq</sub> nighttime residential exterior noise level standards at all nearest receiver locations.

**TABLE 5-4: OPERATIONAL NOISE LEVEL COMPLIANCE**

Receiver Location <sup>1</sup>	Project Operational Noise Levels (dBA L <sub>max</sub> ) <sup>2</sup>		Noise Level Standards (dBA L <sub>max</sub> ) <sup>3</sup>		Noise Level Standards Exceeded? <sup>4</sup>	
	Daytime	Nighttime	Daytime	Nighttime	Daytime	Nighttime
R1	48.8	47.6	55.0	50.0	No	No
R2	39.2	37.2	55.0	50.0	No	No
R3	38.7	36.0	55.0	50.0	No	No

<sup>1</sup> See Exhibit 4-A for the receiver locations.

<sup>2</sup> Proposed Project operational noise levels as shown on Tables 5-2 and 5-3.

<sup>3</sup> Exterior noise level standards for residential land use, as shown on Table 3-1.

<sup>4</sup> Do the estimated Project operational noise source activities exceed the noise level standards?

"Daytime" = 7:00 a.m. to 9:00 p.m.; "Nighttime" = 9:00 p.m. to 7:00 a.m.

*This page intentionally left blank*

## 9 REFERENCES

1. **State of California.** *California Environmental Quality Act, Environmental Checklist Form Appendix G.* 2019.
2. **California Department of Transportation Environmental Program.** *Technical Noise Supplement - A Technical Supplement to the Traffic Noise Analysis Protocol.* Sacramento, CA : s.n., September 2013.
3. **Environmental Protection Agency Office of Noise Abatement and Control.** *Information on Levels of Environmental Noise Requisite to Protect Public Health and Welfare with an Adequate Margin of Safety.* March 1974. EPA/ONAC 550/9/74-004.
4. **U.S. Department of Transportation, Federal Highway Administration, Office of Environment and Planning, Noise and Air Quality Branch.** *Highway Traffic Noise Analysis and Abatement Policy and Guidance.* December 2011.
5. **U.S. Department of Transportation, Federal Highway Administration.** *Highway Traffic Noise in the United States, Problem and Response.* April 2000. p. 3.
6. **U.S. Environmental Protection Agency Office of Noise Abatement and Control.** *Noise Effects Handbook-A Desk Reference to Health and Welfare Effects of Noise.* October 1979 (revised July 1981). EPA 550/9/82/106.
7. **U.S. Department of Transportation, Federal Transit Administration.** *Transit Noise and Vibration Impact Assessment Manual, FTA Report No. 0123.* September 2018.
8. **California Department of Transportation.** *Transportation and Construction Vibration Guidance Manual.* April 2020.
9. **U.S. Department of Transportation, Federal Transit Administration.** *Transit Noise and Vibration Impact Assessment Manual, FTA-VA-90-1003-06.* May 2006.
10. **Office of Planning and Research.** *State of California General Plan Guidelines.* October 2017.
11. **City of La Habra.** *Municipal Code, Chapter 9.32 Noise Control.*

*This page intentionally left blank*

## 10 CERTIFICATIONS

The contents of this noise study report represent an accurate depiction of the noise environment and impacts associated with the proposed Whittier Boulevard Starbucks Project. The information contained in this noise study report is based on the best available data at the time of preparation. If you have any questions, please contact me directly at (619) 788-1971.

William Maddux  
Senior Associate  
URBAN CROSSROADS, INC.  
(619) 788-1971  
[bmaddux@urbanxroads.com](mailto:bmaddux@urbanxroads.com)

### EDUCATION

Bachelor of Science in Urban and Regional Planning  
California Polytechnic State University, Pomona • June 2000

### PROFESSIONAL AFFILIATIONS

ASA – Acoustical Society of America  
APA – American Planning Association  
AWMA – Air and Waste Management Association

### PROFESSIONAL CERTIFICATIONS

Approved Acoustical Consultant • County of San Diego  
FHWA Traffic Noise Model of Training • November 2004  
CadnaA Basic and Advanced Training Certificate • October 2008.

*This page intentionally left blank*

**APPENDIX 3.1:**

**CITY OF LA HABRA MUNICIPAL CODE**

*This page intentionally left blank*

Title 9 PUBLIC PEACE AND WELFARE

## **Chapter 9.32 NOISE CONTROL**

9.32.010 Declaration of policy.

9.32.020 Definitions.

9.32.030 Noise level measurement criteria.

9.32.040 Assignment of residential properties to noise zones.

9.32.050 Noise standards—Exterior.

9.32.060 Noise standards—Interior.

9.32.070 Activities exempt from chapter provisions.

9.32.080 Noise level—Near schools, hospitals and churches.

9.32.090 Noise level—Location of measurement.

9.32.100 Enforcement authority—Interference with prohibited.

9.32.110 Variance—Application—Fee—Applicants remain subject to prosecution.

9.32.120 Variance—Authority to grant—Terms and conditions—Violation unlawful.

9.32.130 Variances—Appeals.

### **9.32.010 Declaration of policy.**

A. In order to control unnecessary, excessive and annoying sounds emanating from areas of the city, it is declared to be the policy of the city to prohibit such sounds generated from all sources as specified in the ordinance codified in this chapter.

B. It is determined that certain sound levels are detrimental to the public health, welfare and safety, and contrary to public interest, therefore, the city council does ordain and declare that creating, maintaining, causing or allowing to create, maintain or cause any noise in a manner prohibited by or not in conformity with the provisions of this chapter, is a public nuisance and shall be punishable as such. (Ord. 923 § 1(A), 1975; Ord. 880 § 1, 1973)

### **9.32.020 Definitions.**

The following words, phrases and terms, as used in the ordinance codified in this chapter, shall have the meaning as indicated in this section:

A. “Ambient noise level” means the all-encompassing noise level associated with a given environment, being a composite of sounds from all sources, excluding the alleged <sup>27</sup>offensive noise, at the location and approximate time at which a comparison with the alleged offensive noise is to be made.

B. “Cumulative period” means an additive period of time composed of individual time segments which may be continuous or interrupted.

C. “Decibel” (dB) means a unit which denotes the ratio between two quantities which are proportional to power: the number of decibels corresponding to the ratio of two amounts of power is ten times the logarithm to the base ten of this ratio.

D. “Emergency machinery, vehicles or work” means any machinery vehicle or work used, employed or performed in an effort to protect, provide or restore safe conditions in the community or for the citizenry, or work by private or public utilities when restoring utility service.

E. “Fixed noise source” means a stationary device which creates sounds while fixed or motionless, including, but not limited to, industrial and commercial machinery and equipment, pumps, fans, compressors, generators, air conditioners and refrigeration equipment.

F. “Grading” means any excavating or filling of earth material or any combination thereof conducted to prepare a site for construction or other improvements thereon.

G. “Impact noise” means the noise produced by the collision of one mass in motion with a second mass which may be either in motion or at rest.

H. “Licensed” means the issuance of a formal license or a permit by the appropriate jurisdictional authority, or where no permits or licenses are issued, the sanctioning of the activity by the jurisdiction as noted in public records.

I. “Mobile noise source” means any noise source other than a fixed source.

J. “Noise level” means the “A” weighted sound pressure level in decibels obtained by using a sound level meter at slow response with a reference pressure of twenty micronewtons per square meter. The unit measurement shall be designated as dB(A).

K. “Noise variance board” means an administrative board of five members appointed by the board of supervisors of the county of Orange, per Title 4, Division 6, Article 1 of the codified ordinances of the county of Orange.

L. “Person” means a person, firm, association, copartnership, joint venture, corporation or any entity, public or private in nature.

M. “Simple noise tone” means a noise characterized by a predominant frequency or frequencies so that other frequencies cannot be readily distinguished.

N. “Sound level meter” means an instrument meeting American National Standard Institutes Standards S1.4-1971 for Type 1 or Type 2 sound level meters or an instrument and the associated recording and analyzing equipment which will provide equivalent data.

O. “Sound pressure level” of a sound, in decibels, means twenty times the logarithm to the base ten of the ratio of the pressure of the sound to a reference pressure, which reference pressure shall be explicitly stated.

P. “Residential property” means a parcel of real property which is zoned, developed, and used for residential purposes, other than transient uses such as hotels and motels. (Ord. 923 § 1(B), (C), (D), 1975; Ord. 880 § 2, 1973)

### **9.32.030 Noise level measurement criteria.**

Any noise level measurements made pursuant to the provisions of this chapter shall be performed using a sound level meter as defined in subsection N of Section [9.32.020](#). (Ord. 880 § 3, 1973)

### **9.32.040 Assignment of residential properties to noise zones.**

The residential properties described in this section are assigned to the following noise zones:

Noise Zone 1: All residential properties, whether incorporated or unincorporated. (Ord. 923 § 1(E), 1975; Ord. 880 § 4, 1973)

### 9.32.050 Noise standards—Exterior.

A. The following noise standards, unless otherwise specifically indicated, shall apply to all residential property within a designated noise zone:

Noise Standards		
Noise Zone	Noise Level	Time Period
1	55 dB(A)	7:00 a.m.—10:00 p.m.
	50 dB(A)	10:00 p.m.—7:00 a.m.

B. It is unlawful for any person at any location within the incorporated area of the city to create any noise, or to allow the creation of any noise on property owned, leased, occupied or otherwise controlled by such person, which causes the noise level, when measured on any other residential property either incorporated or unincorporated, to exceed:

1. The noise standard for a cumulative period of more than thirty minutes in any hour; or
2. The noise standard plus five dB(A) for a cumulative period of more than fifteen minutes in any hour; or
3. The noise standard plus ten dB(A) for a cumulative period of more than five minutes in any hour; or
4. The noise standard plus fifteen dB(A) for a cumulative period of more than one minute in any hour; or
5. The noise standard plus twenty dB(A) for any period of time.

C. In the event the ambient noise level exceeds any of the five noise limit categories set forth in subsection B1 through B5 of this section, the cumulative period applicable to the category shall be increased to reflect the ambient noise level. Furthermore, the maximum permissible noise level shall never exceed the maximum ambient noise level.

D. Each of the noise limits specified in subsection A shall be reduced by five dB(A) for impact or simple tone noises, or for noises consisting of speech or music. (Ord. 923 § 1(F), 1975; Ord. 880 § 5, 1973)

### 9.32.060 Noise standards—Interior.

A. The following noise standards, unless otherwise specifically indicated, shall apply to all residential property within a designated noise zone:

Noise Standards		
Noise Zone	Noise Level	Time Period
1	55 dB(A)	7:00 a.m.—10:00 p.m.
	45 dB(A) <sub>29</sub>	10:00 p.m.—7:00 a.m.

B. It is unlawful for any person at any location within the incorporated area of the city to create any noise, or to allow the creation of any noise on property owned, leased, occupied or otherwise controlled by such person, which causes the noise level, when measured within any other dwelling unit on any residential property to exceed:

1. The noise standard for a cumulative period of more than five minutes in any hour; or
2. The noise standard plus five dB(A) for a cumulative period of more than one minute in any hour; or
3. The noise standard plus ten dB(A) for any period of time.

C. In the event the ambient noise level exceeds any of the three noise limit categories set forth in subsection A1 through A3 of this section, the cumulative period applicable to the category shall be increased to reflect the ambient noise level. Furthermore, the maximum permissible noise level shall never exceed the maximum ambient noise level.

D. Each of the noise limits specified in subsection A shall be reduced by five dB(A) for impact or simple tone noises, or for noises consisting of speech or music. (Ord. 923 § 1(G), 1975; Ord. 880 § 6, 1973)

### **9.32.070 Activities exempt from chapter provisions.**

The following activities shall be exempted from the provisions of this chapter except as regulated under Sections [12.28.090](#) and [12.28.100](#) of this code:

- A. School bands, school athletic and school entertainment events;
- B. Outdoor gatherings, public dances, shows and sporting and entertainment events provided the events are conducted pursuant to a permit issued by the city pursuant to Chapter [5.32](#) relative to the staging of said events;
- C. Activities conducted on public parks, public playgrounds, and public or private school grounds;
- D. Any mechanical device, apparatus or equipment used, related to or connected with emergency machinery, vehicle or work;
- E. Noise sources associated with construction, repair, remodeling, or grading of any real property, provided the activities do not take place between the hours of eight p.m. and seven a.m. on weekdays, including Saturday, or at any time on Sunday or a federal holiday;
- F. All mechanical devices, apparatus or equipment which are utilized for the protection or salvage of agricultural crops during periods of potential or actual frost damage or other adverse weather conditions;
- G. Mobile noise sources associated with agricultural operations provided such operations do not take place between the hours of eight p.m. and seven a.m. on weekdays, including Saturday or at any time on Sunday or a federal holiday;
- H. Mobile noise sources associated with agricultural pest control through pesticide application; provided, that the application is made in accordance with restricted material permits issued by or regulations enforced by the agricultural commissioner;
- I. Noise sources associated with the maintenance of real property provided the activities take place between the hours of seven a.m. and eight p.m. on any day except Sunday or federal holiday, or between the hours of nine a.m. and eight p.m. on Sunday or federal holiday;
- J. Any activity to the extent regulation thereof has been preempted by state or federal law. (Ord. 1367 § 1, 1989; Ord. 923 § 1(H), 1975)

### **9.32.080 Noise level—Near schools, hospitals and churches.**

It is unlawful for any person to create any noise which causes the noise level at any school, hospital or church while the same is in use, to exceed the noise limits as specified in Section 9.32.050 prescribed for the assigned noise zone in which the school, hospital or church is located, or which noise level unreasonably interferes with the use of such institutions or which unreasonably disturbs or annoys patients in the hospital, provided conspicuous signs are displayed in three separate locations within one-tenth of a mile of the institution indicating the presence of a school, church or hospital. (Ord. 923 § 1, 1975; Ord. 880 § 9, 1973)

### **9.32.090 Noise level—Location of measurement.**

The location selected for measuring exterior noise levels shall be at any point on the affected residential property. Interior noise measurement shall be made within the affected residential unit. The measurement shall be made at a point at least four feet from the wall, ceiling or floor nearest the noise source. (Ord. 923 § 1, 1975; Ord. 880 § 11, 1973)

### **9.32.100 Enforcement authority—Interference with prohibited.**

A. The county health officer and his/her duly authorized representatives are directed to enforce the provisions of this chapter. The county health officer and his/her duly authorized representatives are authorized, pursuant to [Penal Code](#) Section 836.5, to arrest any person without a warrant when they have reasonable cause to believe that such person has committed a misdemeanor in their presence.

B. No person shall interfere with, oppose or resist any authorized person charged with enforcement of this chapter while such person is engaged in the performance of his/her duty. (Ord. 923 § 1, 1975; Ord. 880 § 12, 1973)

### **9.32.110 Variance—Application—Fee—Applicants remain subject to prosecution.**

A. The owner or operator of a noise source which violates any of the provisions of this chapter may file an application with the health officer for a variance from the provisions thereof wherein the owner or operator shall set forth all actions taken to comply with the provisions, the reasons why immediate compliance cannot be achieved, a proposed method of achieving compliance, and a proposed time schedule for its accomplishment. The application shall be accompanied by a fee as set by resolution of the city council and on file in the office of the city clerk. A separate application shall be filed for each noise source; provided, however, that several mobile sources under common ownership, or several fixed sources on a single property may be combined into one application.

B. Upon receipt of the application and fee, the health officer shall refer it with his/her recommendations thereon within thirty days to the noise variance board for action thereon in accordance with the provisions of this chapter.

C. An applicant for a variance shall remain subject to prosecution under the terms of this chapter until a variance is granted. (Ord. 1213 §§ 2, 3, 1983; Ord. 923 § 1, 1975; Ord. 880 § 13, 1973)

### **9.32.120 Variance—Authority to grant—Terms and conditions—Violation unlawful.**

The noise variance board shall evaluate all applications for variance from the requirements of this chapter and may grant the variances with respect to time for compliance, subject to such terms, conditions and requirements as it may deem reasonable to achieve maximum compliance with the provisions of this chapter. The terms, conditions and requirements may include, but shall not be limited to, limitations on noise levels and operating hours. Each such variance shall set forth in detail the approved method of achieving maximum compliance and a time schedule for its accomplishment. In its determinations the board shall consider the magnitude of nuisance caused by the offensive noise; the uses of property within the area of impingement by the noise; the time factors related to study, design, financing and construction of remedial work; the economic factors related to age and useful life of equipment; and the general public interest and welfare. Any variance granted by the board shall be by resolution and shall be transmitted to the health officer for enforcement. Any violation of the terms of the variance shall be unlawful. (Ord. 923 § 1, 1975; Ord. 880 § 14, 1973)

### **9.32.130 Variances—Appeals.**

A. Within fifteen days following the decision of the variance board on an application the applicant, the health officer, or any member of the city council, may appeal the decision to the city council by filing a notice of appeal with the secretary of the variance board. In the case of an appeal by the applicant for a variance, the notice of appeal shall be accompanied by a fee to be computed by the secretary on the basis of the estimated cost of preparing the materials required to be forwarded to the city council as discussed hereafter in this section. If the actual cost of such preparation differs from the estimated cost, appropriate payments shall be made either to or by the secretary.

B. Within fifteen days following receipt of a notice of appeal and the appeal fee, the secretary of the variance board shall forward to the city council copies of the application for variance; the recommendation of the health officer; the notice of appeal; and all evidence concerning the application received by the variance board and its decision thereon. In addition, any person may file with the city council written arguments supporting or attacking the decision and the city council may in its discretion hear oral arguments thereon. The city clerk shall mail to the applicant a notice of the date set for hearing of the appeal. The notice shall be mailed at least ten days prior to the hearing date.

C. Within sixty days following its receipt of the notice of the appeal, the city council shall either affirm, modify or reverse the decision of the variance board. Such decision shall be based upon the city council's evaluation of the matters submitted to the city council in light of the powers conferred on the variance board and the factors to be considered, both as enumerated in Sections [9.32.110](#) and [9.32.120](#). As part of its decision the council may direct the variance board to conduct further proceedings on the application. Failure of the city council to affirm, modify or reverse the decision of the variance board within the sixty-day period shall constitute an affirmance of the decision. (Ord. 923 § 14, 1975)

---

## **Contact:**

City Clerk: 562-383-4030

Published by [Quality Code Publishing, Seattle, WA](#). By using this site, you agree to the [terms of use](#).

## **APPENDIX 5.1:**

### **DRIVE-THROUGH SPEAKER MANUFACTURERS TEST DATA**

This page intentionally left blank



Customer Driven

## Memo

### Re: Drive-Thru Sound Pressure Levels From the Menu Board or Speaker Post

The sound pressure levels from the menu board or speaker post are as follows:

1. Sound pressure level (SPL) contours (A weighted) were measured on a typical HME SPP2 speaker post. The test condition was for pink noise set to 84 dBA at 1 foot in front of the speaker. All measurements were conducted outside with the speaker post placed 8 feet from a non-absorbing building wall and at an oblique angle to the wall. These measurements should not be construed to guarantee performance with any particular speaker post in any particular environment. They are typical results obtained under the conditions described above.
2. The SPL levels are presented for different distances from the speaker post:

Distance from the Speaker (Feet)	SPL (dBA)
1 foot	84 dBA
2 feet	78 dBA
4 feet	72 dBA
8 feet	66 dBA
16 feet	60 dBA
32 feet	54 dBA

3. The above levels are based on factory recommended operating levels, which are preset for HME components and represent the optimum level for drive-thru operations in the majority of the installations.

Also, HME incorporates automatic volume control (AVC) into many of our Systems. AVC will adjust the outbound volume based on the outdoor, ambient noise level. When ambient noise levels naturally decrease at night, AVC will reduce the outbound volume on the system. See below for example:

Distance from Outside Speaker	Decibel Level of standard system with 45 dB of outside noise <u>without</u> AVC	Decibel level of standard system with 45 dB of outside noise <u>with</u> AVC active
1 foot	84 dBA	60 dBA
2 feet	78 dBA	54 dBA
4 feet	72 dBA	48 dBA
8 feet	66 dBA	42 dBA
16 feet	60 dBA	36 dBA

If there are any further questions regarding this issue please contact HME customer service at 1-800-848-4468.

Thank you for your interest in HME's products.

## Drive-Thru Sound Levels

This white paper addresses sound pressure levels (SPL) from the drive-thru communications system, which is a concern especially where municipal noise abatement rules exist. The paper includes typical measurements for a standard HME drive-thru system.

**Note:** Because every site is different and each municipality has its own regulations, HME is unable to make specific recommendations for compliance or give any assurance that any particular system configuration will comply with any given regulations. Statements made in this paper should be taken as general guidelines, but to ensure compliance, the site planner should retain the services of a qualified acoustic consultant equipped to make the necessary measurements.

Sound pressure levels are measured in units of dB SPL and usually include a frequency variable weight referred to as "A Weighting". For this reason, the units are frequently written as "dBA SPL" and that notation will be used throughout this paper.

In the drive-thru, the primary source of sound other than the vehicles themselves is often the drive-thru communications system. There is the sound from the speaker (outbound) which comes from the order taker or greeter. There is also the sound of the voice of the customer in the vehicle (inbound). This paper only addresses outbound sound. The outbound audio is delivered by the speaker and must be loud enough to be clearly heard by the customer over the noise of the customer's vehicle, any local traffic and other ambient background noises in the area. However, if it is too loud, the sound can be objectionable to neighbors or even violate specific regulations.

The sound pressure level from a speaker decreases as the distance away increases. However, it can be difficult to predict how much reduction will actually occur. For a single point sound source like an alarm bell hanging in air, the SPL drops approximately 6 dB every time the distance from the source doubles. Thus, if one starts one foot away, the level will be 36 dB lower when one is 64 feet away. Unfortunately, speakers are neither single point sources nor are they hanging in air. Rather, speakers are mounted in a variety of different type enclosures. Further, surrounding buildings, and cars in proximity all effect the sound's direction and energy. All of this tends to make the sound more directional and the SPL at distance less predictable.

HME base stations are equipped with a feature known as Automatic Volume Control or "AVC" which can be used to reduce the outbound sound pressure level based on ambient noise. When AVC is active, the microphone in the speaker post is used to measure the ambient noise level and the outbound level is reduced to a level that is approximately 14 - 15 dB above the ambient noise, but it **never** increases the level above what would be heard with AVC turned off. This feature can considerably reduce the SPL during quiet periods and may help in satisfying local requirements. Another feature of the EOS HD system is "Scheduled Outbound" volume settings. With this feature, the outbound volume can be programmed to lower levels at night or other known quiet periods.

This paper provides some typical measurements taken in a hemi-anechoic chamber that simulates an outdoor environment under specific circumstances. Measurements in the chamber allow us to simulate an open parking lot with any level of ambient noise we choose. These measurements can be used as a guide for what levels might occur in a drive-thru installation. SPL levels at distances greater than 16 ft from the speaker post are calculated based on projected SPL decreases at distance. Additionally, these results were compared with previous outdoor measurements with the same model of speaker and speaker post to verify the validity of the calculated results.

## Drive-Thru Sound Levels

All measurements provided here were taken using the following drive-thru equipment:

- Base station: HME EOS HD set to factory default level (outbound volume “15”).
- Communicator: HME COM6200
- Speaker: HME SP10
- Microphone: HME DM5 (required for AVC operation)
- Speaker post: Texas Digital model 107150

SPL Measurements were taken with:

- NTI Minilizer ML1 with Mini SPL microphone set to A-weight, slow response
- Ambient background noise level: ~32 dBA SPL (room noise floor)

These measurements were taken using “pink noise”, a type of noise frequently used for acoustic testing, at levels simulating the loudest speech expected from an order taker. Initial measurements were taken with AVC off and no obstructions or reflecting surfaces in front of the speaker. These are not “normal” conditions for a drive-thru, but they do yield one worst-case measurement. Measurement accuracy for any SPL measurement can be taken to be  $\pm 1$  dB. The speaker in the test speaker post is centered 1.5 feet (18 inches) from the floor and the microphone is centered at 46 inches from the floor. All measurements are taken directly in front of the speaker post.

SPL tests without AVC are made with continuous pink noise supplied to a backpack communicator at a level comparable to that of an order taker speaking into the microphone. Measurements are then taken with the measurement microphone on a stand. These measurements were taken at various heights above the floor and distances from the speaker post in order to have a good picture of the way that SPL changes with distance.

Measurements are taken at heights of 1.5 feet, 3 feet, 6 feet, and 9 feet above the floor and at linear distances of 1 foot, 2 feet, 4 feet, 8 feet, and 16 feet in front of the post. From this data, we are able to extrapolate projected SPL at greater distances (assuming no obstructions).

To verify the validity of these measurements, they have been checked for self-consistency and they have been checked against measurements taken outdoors in 2010 with the same model speaker and post. In all cases, the SPLs check within  $\pm 1$  dB.

SPL tests with AVC are made at a single position with different ambient noise levels in order to demonstrate and measure AVC function. This single position approximates the position of the drive-thru customer while placing an order. These measurements are made with continuous pink noise supplied to large speakers at the back of the room to simulate ambient noise. Pulsed pink noise is used to simulate order taker speech. These measurements are taken 46 inches above the floor and 48 inches from the post. Correction factors are then calculated to allow the SPL to be estimated at other positions and distances.

Changing the outbound volume from its default setting of “15” (on a scale of 0 – 20) will change both the outbound SPL and the effect that AVC has on the outbound level. A table of correction factors is provided at the end of this paper for different volume settings.

Figure 1 is a graph showing plots of measured (out to 16 feet) and extrapolated (32 and 64 feet) SPL at various distances from the speaker post and at four different heights above the ground. Since the speaker is mounted 1.5 feet above the ground, the top curve represents the SPL directly in line with the speaker axis. From these plots, it is easy to see that the SPL falls off approximately 5 dB every time the distance doubles when on axis. When off axis, the SPL curves are initially shallower but ultimately approach the 5 dB curve as the distance increases. If the speaker were mounted at a different height in a similar enclosure, the top curve would represent the SPL at that height. For example, if the speaker were mounted at a height of 3 feet, this curve would represent the SPL at a height of 3 feet.

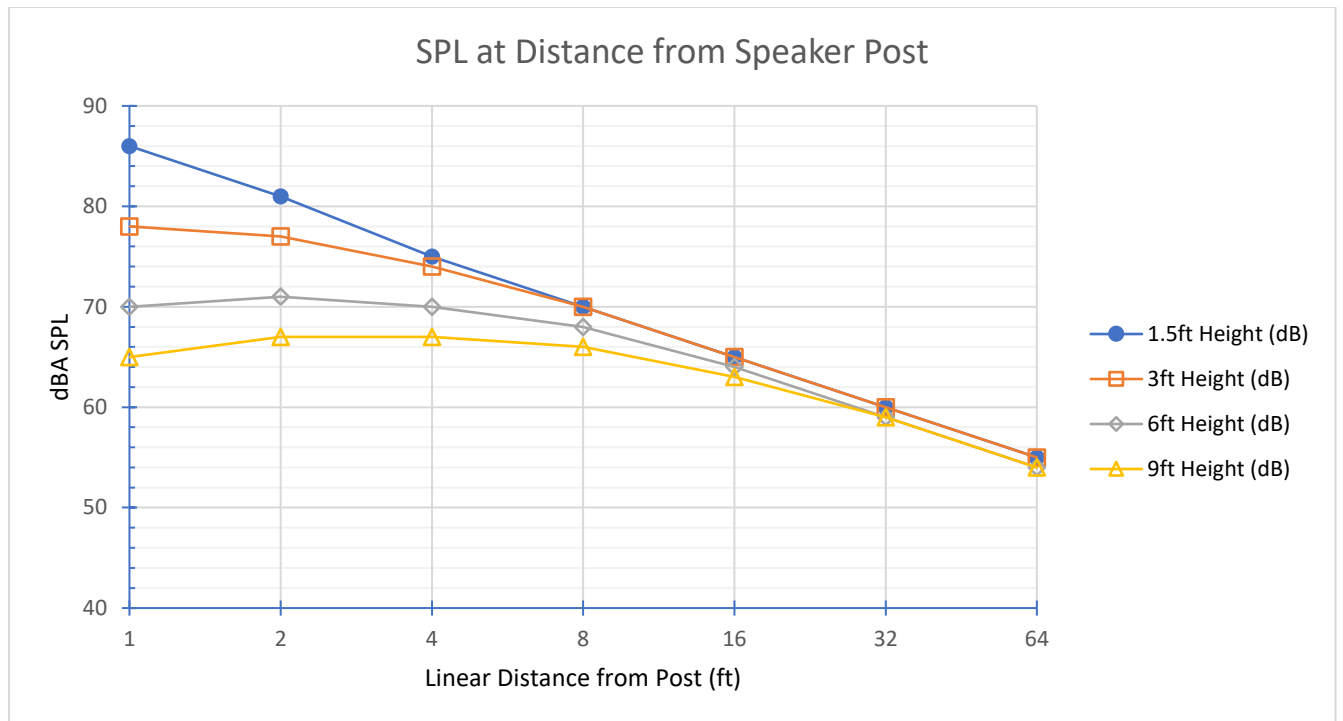

Figure 1 – Plots of SPL vs Distance at Various Heights

Figure 2 is a graph showing plots of measured SPL (at the 1.5-foot level) taken outdoors at specific distances up to 55 feet compared with measurements and extrapolations from the acoustic chamber. This graph shows the very close agreement between the outdoor measurements and the chamber measurements.

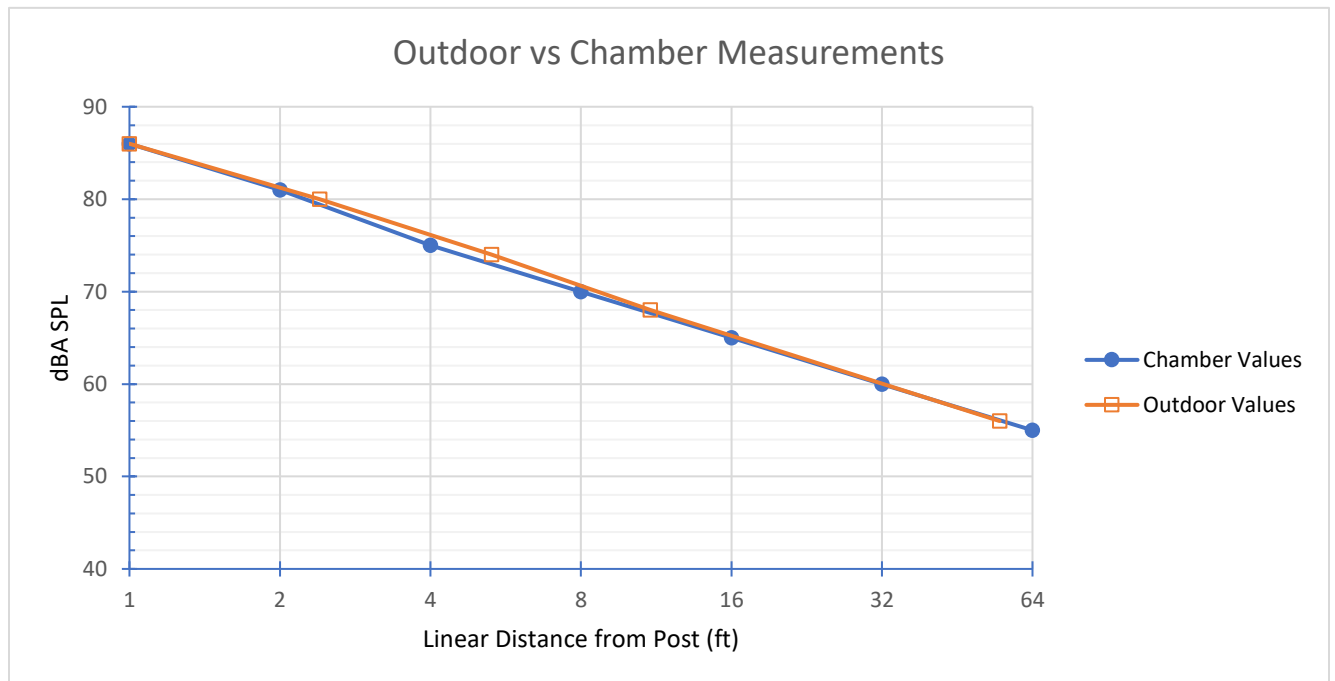

Figure 2 – Plots of SPL Measured Outdoors and in Anechoic Chamber

## AVC Operation

AVC uses the inbound microphone to measure the ambient noise level in the drive-thru and adjust the outbound level down so that it is never more than 15 dB above the ambient noise level. This is particularly useful at night when there is less traffic on surrounding streets and fewer cars in the drive-thru. It may also be useful in situations where the regulations do not specify specific sound pressure levels but use terms like “reasonable” or “sufficient”. Because AVC adjusts continuously, it ensures that the outbound level changes as the conditions change.

AVC is calibrated to adjust the SPL as measured at a point near the microphone. SPL measurements have been taken at a point 46 inches above the ground and 48 inches in front of the post. Figures 4-6 are based on these measurements.

Since AVC adjusts based on the noise level measured at the speaker post, a noisy vehicle will drive the outbound level up. Thus, the use of AVC will not guarantee that the SPL is below any particular level for all vehicles or conditions. However, it will keep the outbound level from becoming excessively loud. If absolute limits are needed, Scheduled Outbound volume should be used instead of AVC.

Figure 3 is a graph of the amount of attenuation that is applied to the outbound signal for various ambient noise levels. This represents the difference in outbound level between AVC off and AVC on. Attenuation only occurs when the ambient noise level is below 60 dBA SPL. The attenuation amounts shown on this graph may be used in conjunction with SPL measurements to estimate the SPL at various locations for given ambient noise levels.

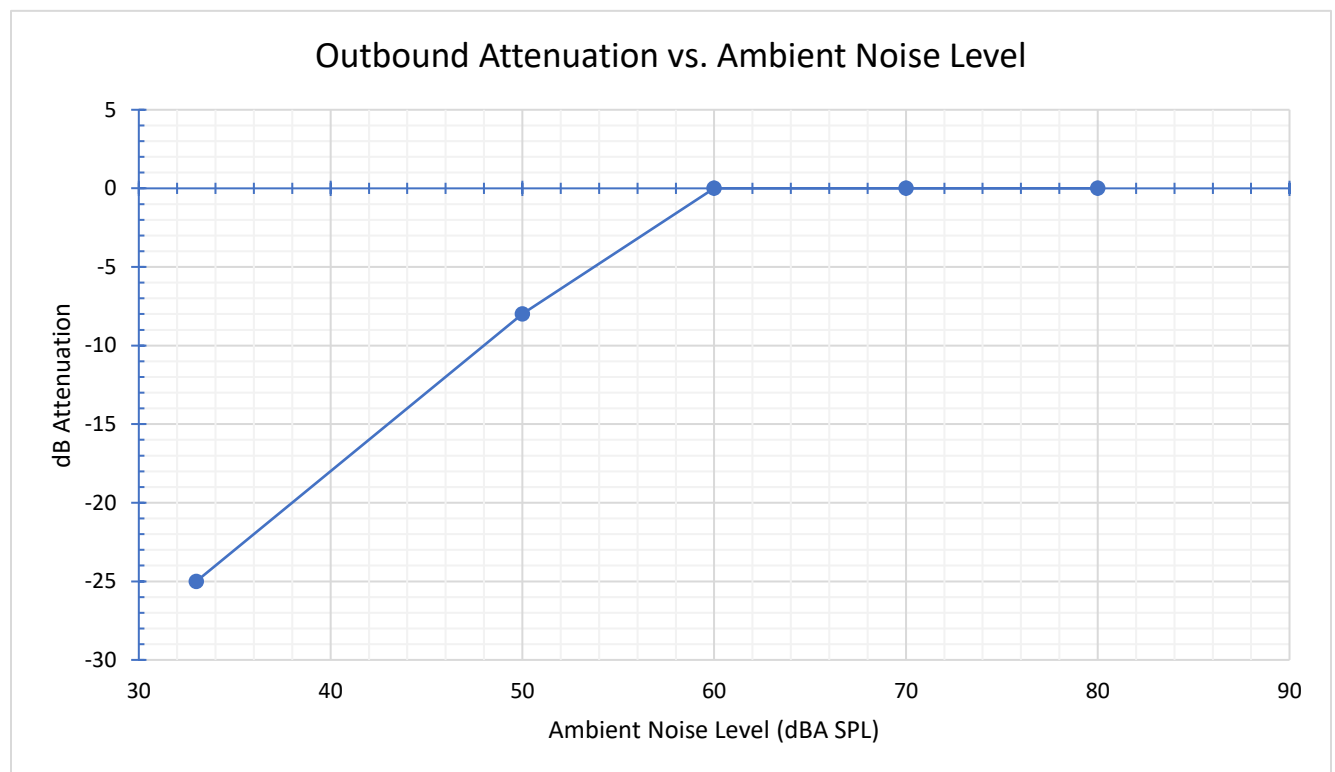

Figure 3 – AVC Outbound Attenuation for Various Ambient Noise Levels

## Drive-Thru Sound Levels

Figure 4 is a graph of the total SPL (ambient noise plus outbound audio) measured at the approximate position of the customer (46 inches above the ground and 48 inches in front of the post). From this graph it can be seen that at ambient levels below 60 dBA SPL, the total SPL is approximately 14 dB above the ambient noise as expected with AVC on. Above 60 dBA ambient, the total level is less than 14 dB louder than the ambient level. Once the ambient noise level reaches approximately 80 dBA SPL, there is little contribution from the outbound audio.

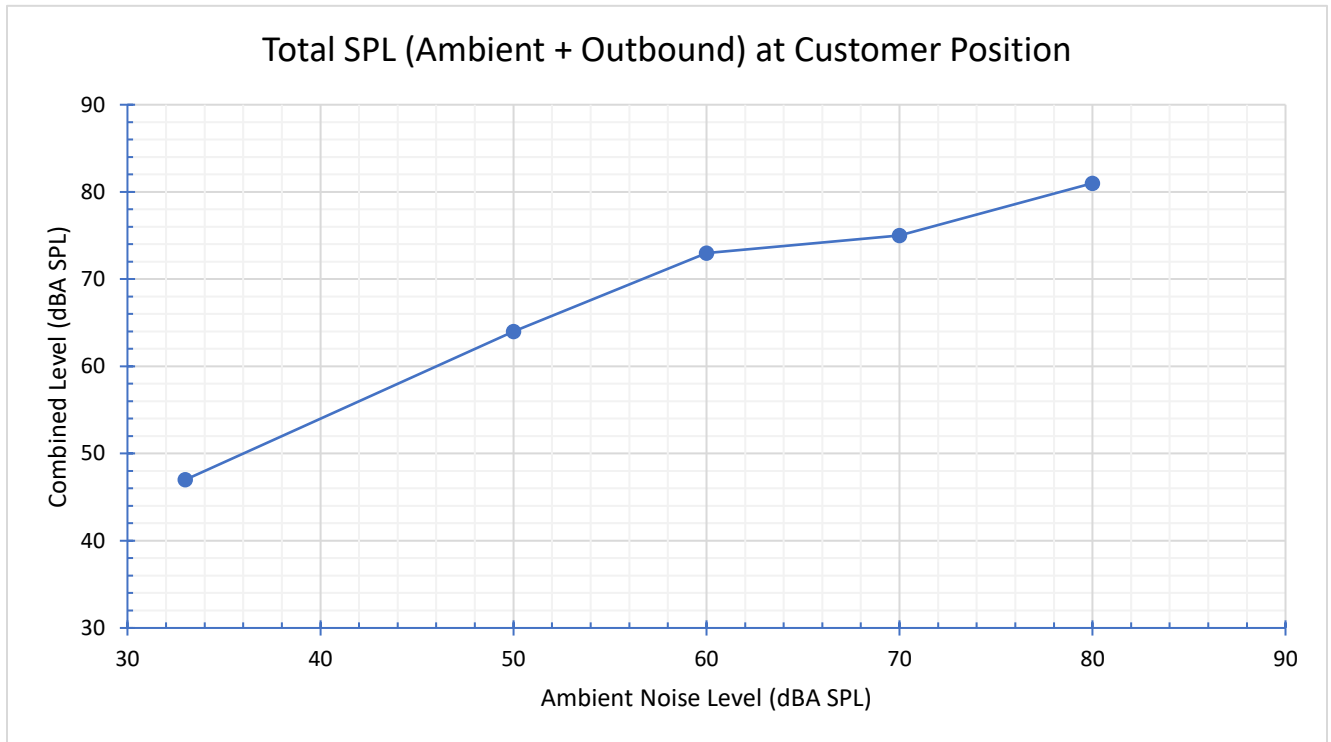

Figure 4 – Total Sound Pressure Level at Customer Position

Figure 5 is a graph showing the total SPL (ambient plus outbound) plotted over distance for various ambient noise levels. This assumes that the ambient noise level does not vary with distance from the post. This assumption is likely valid in a large city where the noise is general and widespread. In an installation where the majority of the ambient noise comes from a nearby street or highway, there will be variation in the ambient noise level. At higher ambient noise levels, there is little or no contribution from the outbound audio at far distances from the post.

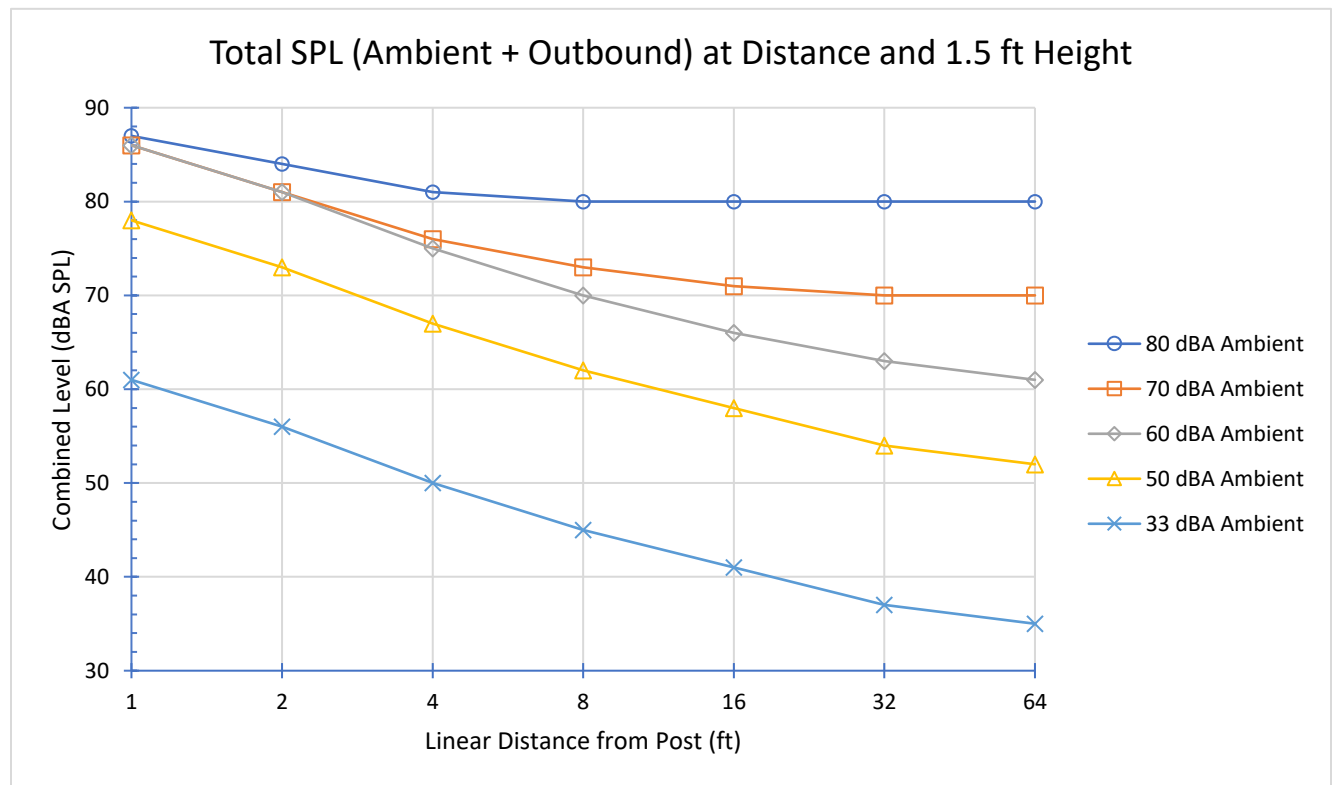

Figure 5 – Total Sound Pressure Level at Distances from Post

### SPL Estimation Guidelines

HME cannot provide guarantees of SPL in specific situations. Only on-site measurements can confirm sound pressure levels at any particular location. However, these measurements can help predict general values. When there are cars in the vicinity of the speaker post, they will block and reflect sound in various ways and while they will change the direction that the sound travels, they will not increase the SPL higher than it would be on the main axis of the speaker. Echoes from surrounding buildings can cause sounds to reinforce each other in unpredictable ways. It is beyond the scope of this paper to make any predictions of SPL when there are buildings closer than 100 feet or so.

The equations presented here can be used along with the graphs to make estimations of SPL at other distances and under other ambient noise conditions. They depend on various assumptions and should only be used for making estimates.

### EOS Volume Correction

All measurements have been taken with the outbound volume set to the default setting of 15. The table below gives correction factors for the outbound SPL given different volume settings. The correction factor should be added to the outbound SPL to get the expected SPL for that volume setting. Note that these factors can be used when setting Scheduled Outbound levels as well. For example, if the outbound level needs to be 10 dB lower at night, the nighttime volume would be set to “9”.

Volume Setting	8	9	10	11	12	13	14	15	16	17	18	19	20
Correction Factor	-15	-10	-7	-4	-3dB	-2dB	-1dB	0	1dB	2dB	3dB	4dB	5dB

Table 1 – SPL Correction Factors

### Estimating SPL (no AVC)

When AVC is off, the outbound level from the speaker will be constant. Using the graph of Figure 1, it is possible to estimate the SPL at various heights and distances within a few dB. At distances less than 16 ft, it is best to approximate the level by estimating where the point would be on the graph. It is important to remember that the distance scale is logarithmic in base 2. That means that each division represents a doubling of distance. For distances greater than 16 ft, it is reasonable to assume that the level will decrease by 5 dB each time the distance doubles. The predicted SPL at some distance beyond 64 ft would be given by this equation:

$$SPL = 55 - \left(5 \times \frac{\log\left(\frac{d}{64}\right)}{\log 2}\right) \text{ where } d \text{ is the distance in ft}$$

Thus, the estimated SPL at 100 ft is  $55 - \left(5 \times \frac{\log\left(\frac{100}{64}\right)}{\log 2}\right) = 52 \text{ dBA}$ .

### Estimating Outbound AVC Attenuation

When AVC is on, the outbound level will adjust based on the ambient noise level as measured by the inbound microphone. The amount of attenuation can be calculated for situations where the ambient noise level is 50 dBA SPL or lower. Given a configuration where the microphone is located approximately 28 inches above the speaker, the approximate attenuation will be given by this equation (as shown in Figure 3):

$$Attn = (Nl + 14) - 72 \text{ where } Nl \text{ is the noise level}$$

Thus, the attenuation for an ambient noise level of 47 dBA is -11 dB. If we combine this with the earlier example and ask for the estimated SPL at 100 ft with AVC on and an ambient noise level of 47 dBA, we simply add the attenuation number to the estimated SPL. In this case, the estimated outbound SPL would be 52 - 11 or 41 dBA. Since this level is below the ambient noise level, it is unlikely to be heard. However, the total combined SPL can also be calculated.

### Calculating Total Combined SPL

The ambient noise level and the outbound level will add as RMS values. This equation is used to calculate the total:

$$SPL_{tot} = 20 \times \log \sqrt{10^{\frac{Nl}{10}} + 10^{\frac{SPL}{10}}} \text{ where } Nl \text{ is the noise level and } SPL \text{ is the outbound SPL}$$

For the previous example this is  $20 \times \log \sqrt{10^{\frac{47}{10}} + 10^{\frac{41}{10}}}$  or 48 dBA SPL.

**APPENDIX 5.2:**  
**HVAC MANUFACTURERS SPECIFICATIONS**

This page intentionally left blank



Job Name: McDonalds Palmdale  
 Prepared By:  
 Unit Tag: RTU-2  
 Quantity: 1

# Trane Precedent Gas/Electric Packaged Rooftop

## Unit Overview - YHC048F3RLA\*\*K2D5A1A0000A000000000000000

Application	Unit Size	Supply Fan		External Dimensions (in.)			Operating Weight		EER	IEER/SEER	Elevation
		Airflow	External Static Pressure	Height	Width	Length	Minimum	Maximum			
DX cooling, gas heat	4 Ton (048)	1600 cfm	0.800 in H2O	3.41 ft	4.44 ft	7.39 ft	711.0 lb	948.0 lb	13.5 EER	15.00	

## Unit Features

<b>Fresh Air Selection</b>	Low Leak Econ-dry bulb 0-100%/bar rel 3p
<b>SupplyFan/Drive/ MotorType</b>	Optional belt drive motor
<b>Condenser coil protection</b>	CompleteCoat? w/hail guard
<b>Hinged Service Access/Filters</b>	Std panel/2 in pltd filters MERV 13



## Unit Electrical

<b>Voltage/phase/hertz</b>	208-230/60/3
<b>MCA</b>	24.00 A
<b>MOP</b>	35.00 A

## Controls

<b>Unit Controls</b>	Microprocessor controls
<b>System Monitoring Controls 1</b>	Condensate drain pan overflow switch

## Cooling Section

		Capacity	
<b>Entering Dry Bulb</b>	80.00 F	<b>Gross Total</b>	49.93 MBh
<b>Entering Wet Bulb</b>	67.00 F	<b>Gross Sensible</b>	35.07 MBh
<b>Ambient Temp</b>	95.00 F	<b>Net Total</b>	47.61 MBh
<b>Leaving Coil Dry Bulb</b>	59.70 F	<b>Net Sensible</b>	32.76 MBh
<b>Leaving Coil Wet Bulb</b>	56.92 F	<b>Fan Motor Heat</b>	2.32 MBh
<b>Leaving Unit Dry Bulb</b>	61.31 F	<b>Refrig Charge-circuit 1</b>	5.2 lb
<b>Leaving Unit Wet Bulb</b>	57.54 F		
<b>Refrigeration System Options</b>			
<b>Leaving Dew Point</b>	55.09 F		

## Heating Section

<b>Heat Type</b>	Gas Heat
<b>Heating Stages</b>	1
<b>Output Heating Capacity</b>	49.00 MBh
<b>Output Heating Capacity with Fan</b>	51.32 MBh
<b>Heating EAT</b>	70.00 F
<b>Heating LAT</b>	98.70 F
<b>Heating Temp Rise</b>	28.70 F

## Fan Section

Indoor Fan Data		Outdoor Fan Data	
<b>Type</b>	FC Centrifugal	<b>Type</b>	Propeller
<b>Drive Type</b>	Belt	<b>Fan Quantity</b>	1
<b>Evap Fan FLA</b>	3.40 A	<b>Drive Type</b>	Direct
<b>Indoor Fan Performance</b>		<b>Outdoor Fan Performance</b>	
<b>Airflow</b>	1600 cfm	<b>Outdoor Motor Power</b>	0.34 kW
<b>Design ESP</b>	0.800 in H2O	<b>Condenser Fan FLA</b>	2.50 A
<b>Component SP</b>	0.180 in H2O		
<b>Total SP</b>	0.980 in H2O		
<b>Supply Motor Horsepower</b>	1.000 hp		
<b>Indoor Motor Operating Power</b>	0.67 bhp		
<b>Indoor Motor Power</b>	0.50 kW		
<b>Indoor RPM</b>	976 rpm		

## Compressor Section

<b>Power</b>	3.12 kW
<b>Circuit 1 RLA</b>	13.70 A
<b>Circuit 2 RLA</b>	0.00 A



## Acoustics

Sound Path	63 Hz	125 Hz	250 Hz	500 Hz	1 kHz	2 kHz	4 kHz	8 kHz
Ducted Discharge	85 dB	75 dB	70 dB	66 dB	62 dB	59 dB	57 dB	48 dB
Ducted Inlet	83 dB	71 dB	60 dB	56 dB	53 dB	50 dB	48 dB	43 dB
Outdoor Noise	80 dB	86 dB	84 dB	85 dB	83 dB	79 dB	73 dB	67 dB

Note:Ducted Inlet and Ducted Discharge Sound Power Levels are in accordance with AHRI 260.

Note:Outdoor Sound Power Levels are in accordance with AHRI 270.

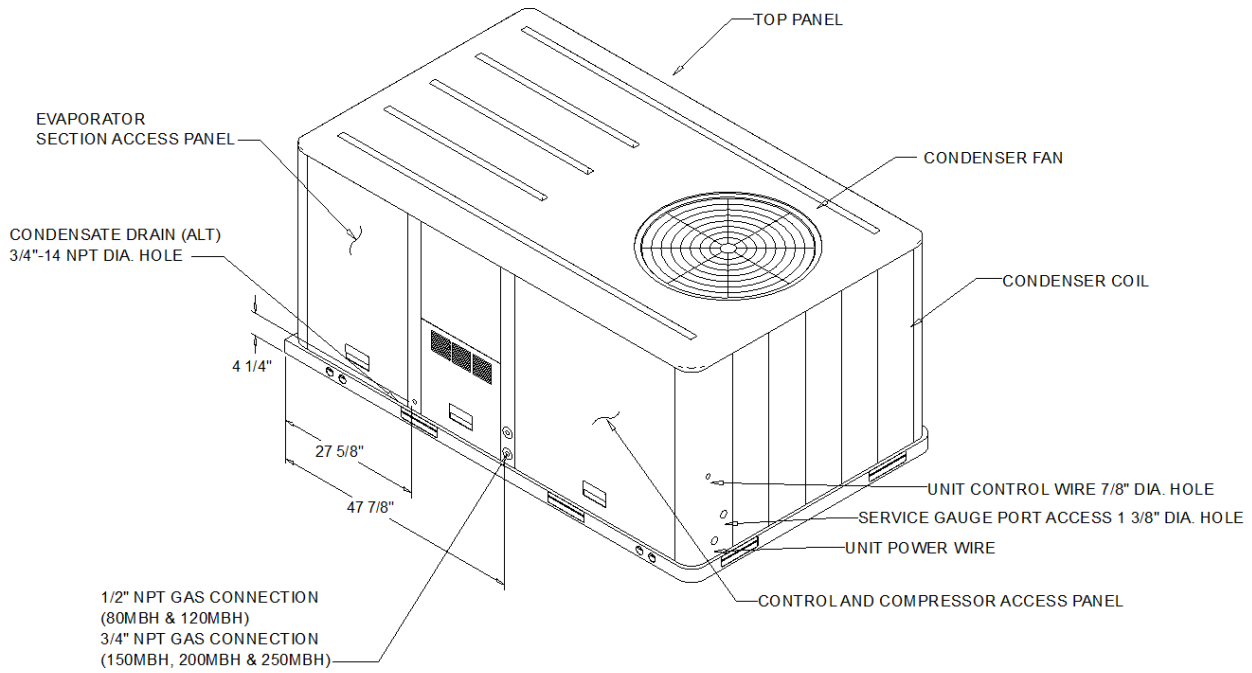

- NOTES:
1. THRU -THE -BASE ELECTRICAL AND GAS IS NOT STANDARD ON ALL UNITS.
  2. VERIFY WEIGHT, CONNECTION, AND ALL DIMENSION WITH INSTALLER DOCUMENTS BEFORE INSTALLATION

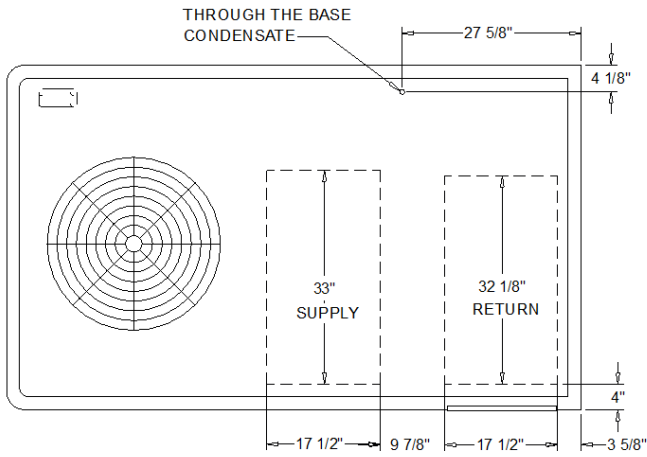

PLAN VIEW UNIT

DIMENSION DRAWING

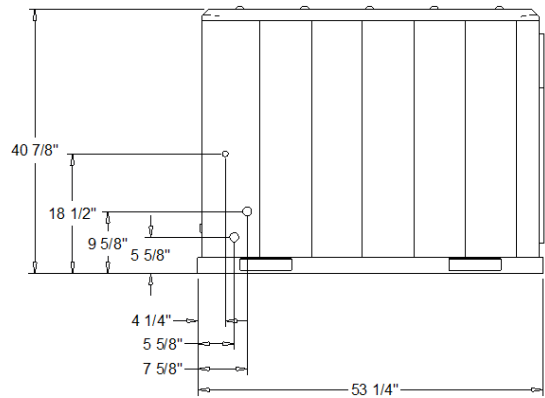
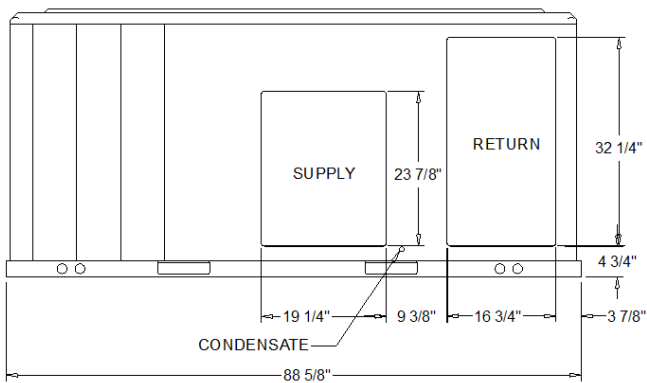

HORIZONTAL AIR FLOW

PACKAGED GAS / ELECTRICAL

DIMENSION DRAWING

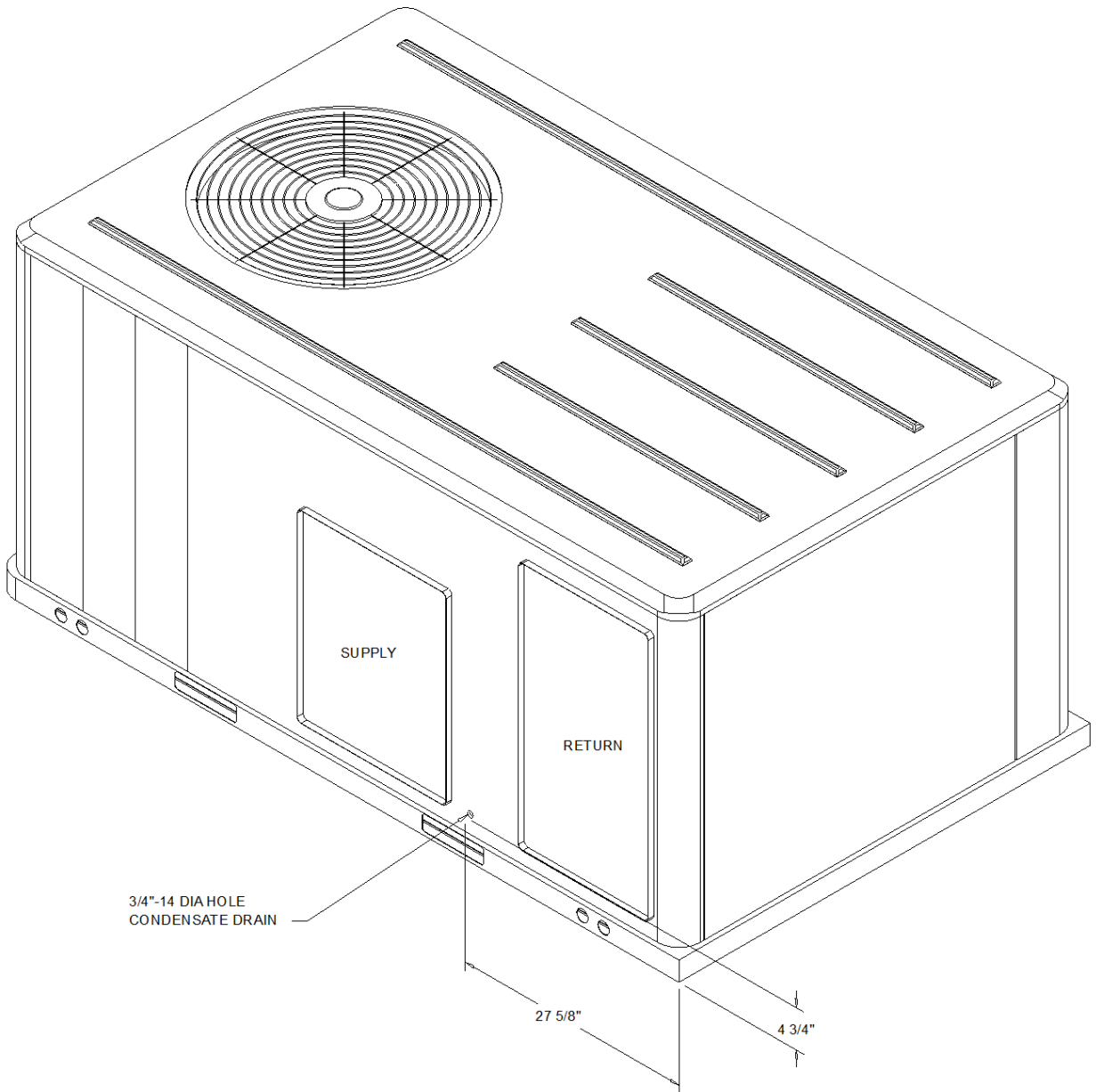

ISOMETRIC-PACKAGED COOLING

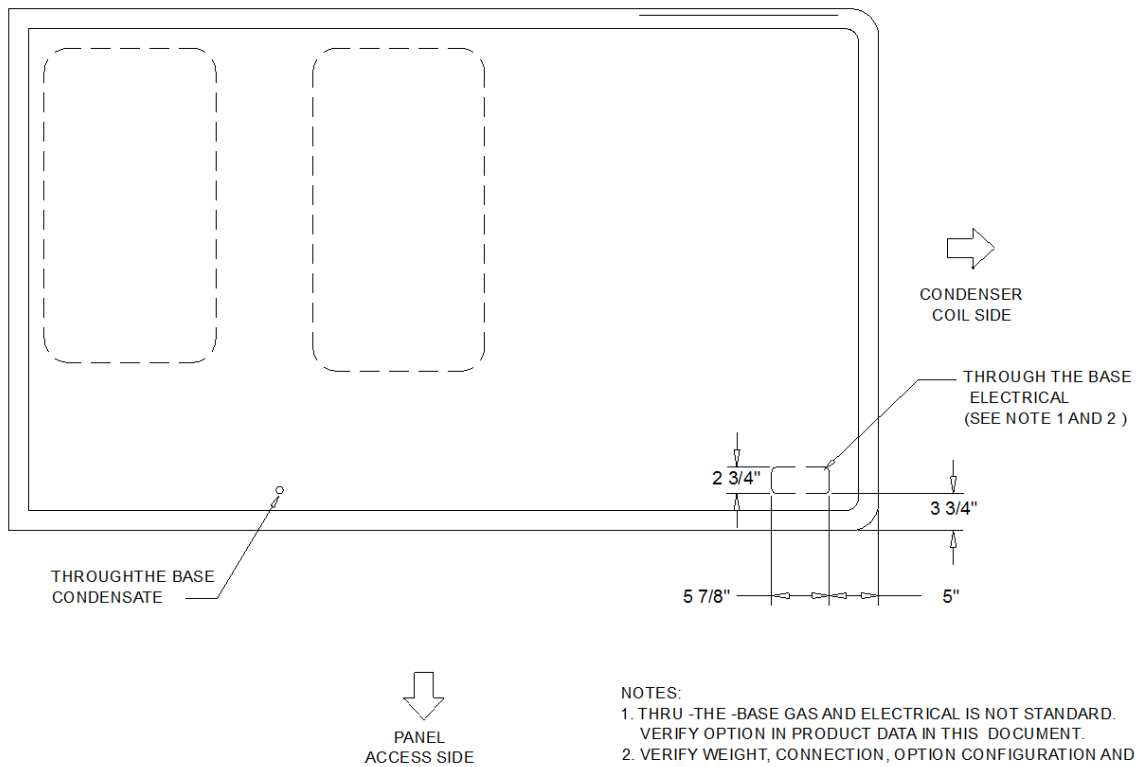
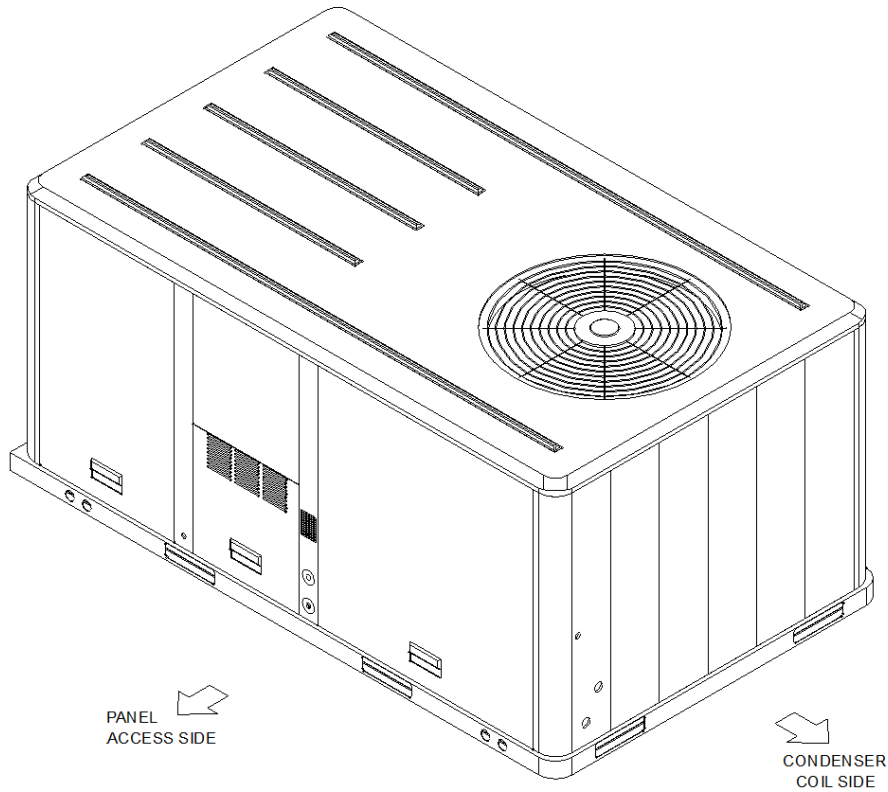

**THRU THE BASE ELECTRICAL**

PLAN / ISO VIEW DRAWING



### ELECTRICAL / GENERAL DATA

<b>GENERAL</b> (2)(4)(6) Model: YHC048F Oversized Motor Unit Operating Voltage: 187-253 F Unit Primary Voltage: 208 MCA: N/A Unit Secondary Voltage: 230 MFS: N/A Unit Hertz: 60 MCB: N/A Unit Phase: 3 EER/SEER 13.35/15.0 Standard Motor MCA: 24.6 MCA: N/A MFS: 35.0 MFS: N/A MCB: 35.0 MCB: N/A		<b>HEATING PERFORMANCE</b> HEATING - GENERAL DATA Heating Model: Low Heating Input (BTU): 60000 Heating Output (BTU): 49000 No. Burners: 2 No. Stages: 1 Gas Inlet Pressure Natural Gas (Min/Max): 4 1/2"/14" LP (Min/Max) 11"/14" Gas Pipe Connection Size: 1/2"																						
<b>INDOOR MOTOR</b> <table border="0" style="width:100%"> <tr> <td style="width:33%">Standard Motor</td> <td style="width:33%">Oversized Motor</td> <td style="width:33%">Field Installed Oversized Motor</td> </tr> <tr> <td>Number: 1</td> <td>Number: N/A</td> <td>Number: N/A</td> </tr> <tr> <td>Horsepower: 1.0</td> <td>Horsepower: N/A</td> <td>Horsepower: N/A</td> </tr> <tr> <td>Motor Speed (RPM): -</td> <td>Motor Speed (RPM): N/A</td> <td>Motor Speed (RPM): N/A</td> </tr> <tr> <td>Phase: 3</td> <td>Phase: N/A</td> <td>Phase: N/A</td> </tr> <tr> <td>Full Load Amps: 3.4</td> <td>Full Load Amps: N/A</td> <td>Full Load Amps: N/A</td> </tr> <tr> <td>Locked Rotor Amps: 32.2</td> <td>Locked Rotor Amps: N/A</td> <td>Locked Rotor Amps: N/A</td> </tr> </table>				Standard Motor	Oversized Motor	Field Installed Oversized Motor	Number: 1	Number: N/A	Number: N/A	Horsepower: 1.0	Horsepower: N/A	Horsepower: N/A	Motor Speed (RPM): -	Motor Speed (RPM): N/A	Motor Speed (RPM): N/A	Phase: 3	Phase: N/A	Phase: N/A	Full Load Amps: 3.4	Full Load Amps: N/A	Full Load Amps: N/A	Locked Rotor Amps: 32.2	Locked Rotor Amps: N/A	Locked Rotor Amps: N/A
Standard Motor	Oversized Motor	Field Installed Oversized Motor																						
Number: 1	Number: N/A	Number: N/A																						
Horsepower: 1.0	Horsepower: N/A	Horsepower: N/A																						
Motor Speed (RPM): -	Motor Speed (RPM): N/A	Motor Speed (RPM): N/A																						
Phase: 3	Phase: N/A	Phase: N/A																						
Full Load Amps: 3.4	Full Load Amps: N/A	Full Load Amps: N/A																						
Locked Rotor Amps: 32.2	Locked Rotor Amps: N/A	Locked Rotor Amps: N/A																						
<b>COMPRESSOR</b> Circuit 1/2 Number: 1 Horsepower: 3.5 Phase: 3 Rated Load Amps: 13.7 Locked Rotor Amps: -		<b>OUTDOOR MOTOR</b> Number: 1 Horsepower: 0.40 Motor Speed (RPM): 1075 Phase: 1 Full Load Amps: 2.5 -																						
<b>POWER EXHAUST ACCESSORY</b> (3,7) (Field Installed Power Exhaust) Phase: N/A Horsepower: N/A Motor Speed (RPM): N/A Full Load Amps: N/A Locked Rotor Amps: N/A	<b>FILTERS</b> Type: Throwaway Furnished: Yes Number: 4 Recommended: 16"x25"x2"	<b>REFRIGERANT</b> (2) Type: R-410 Factory Charge Circuit #1: 5.2 lb Circuit #2: N/A																						

**NOTES:**

1. Maximum (HACR) Circuit Breaker sizing is for installations in the United States only.
2. Refrigerant charge is an approximate value. For a more precise value, see unit nameplate and service instructions.
3. Value does not include Power Exhaust Accessory.
4. Value includes oversized motor.
5. Value does not include Power Exhaust Accessory.
6. EER is rated at AHRI conditions and in accordance with DOE test procedures.
7. Installation of this power exhaust kit will affect unit level MCA and could affect MOP sizing having a direct impact on existing field wiring and unit protection devices. The change in MCA/MOP is the sole responsibility of the field installing party. Trane will not issue new nameplates as a result of this power exhaust accessory installation. FLA of the power exhaust kit option must be added to the MCA of the unit for building supply conductor sizing determination.





CLEARANCE FROM TOP OF UNIT 72"

CLEARANCE 36"

CLEARANCE 48"

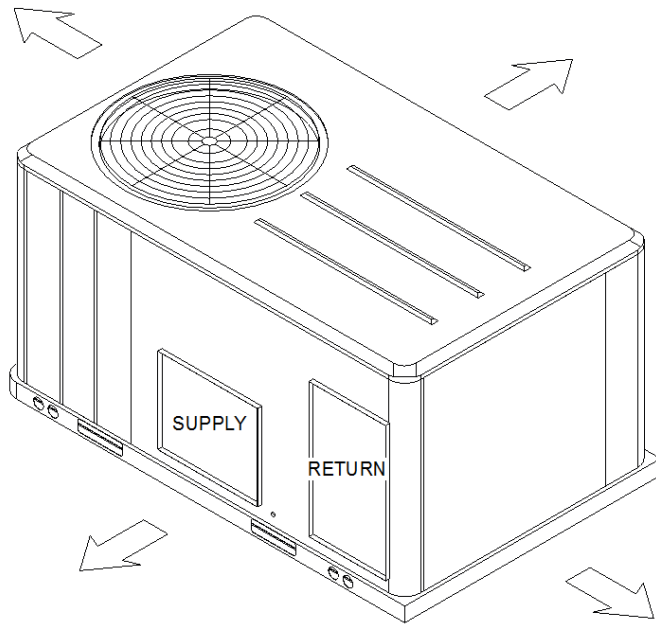

DOWNFLOW CLEARANCE 36"  
HORIZONTAL CLEARANCE 18"

CLEARANCE 36"

PACKAGED GAS / ELECTRIC  
CLEARANCE

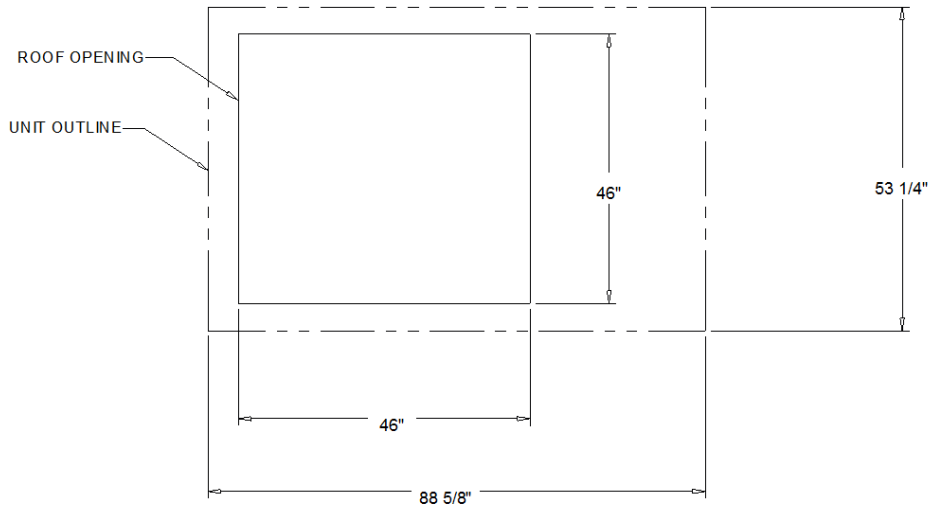

PACKAGED GAS / ELECTRIC  
DOWNFLOW TYPICAL ROOF OPENING

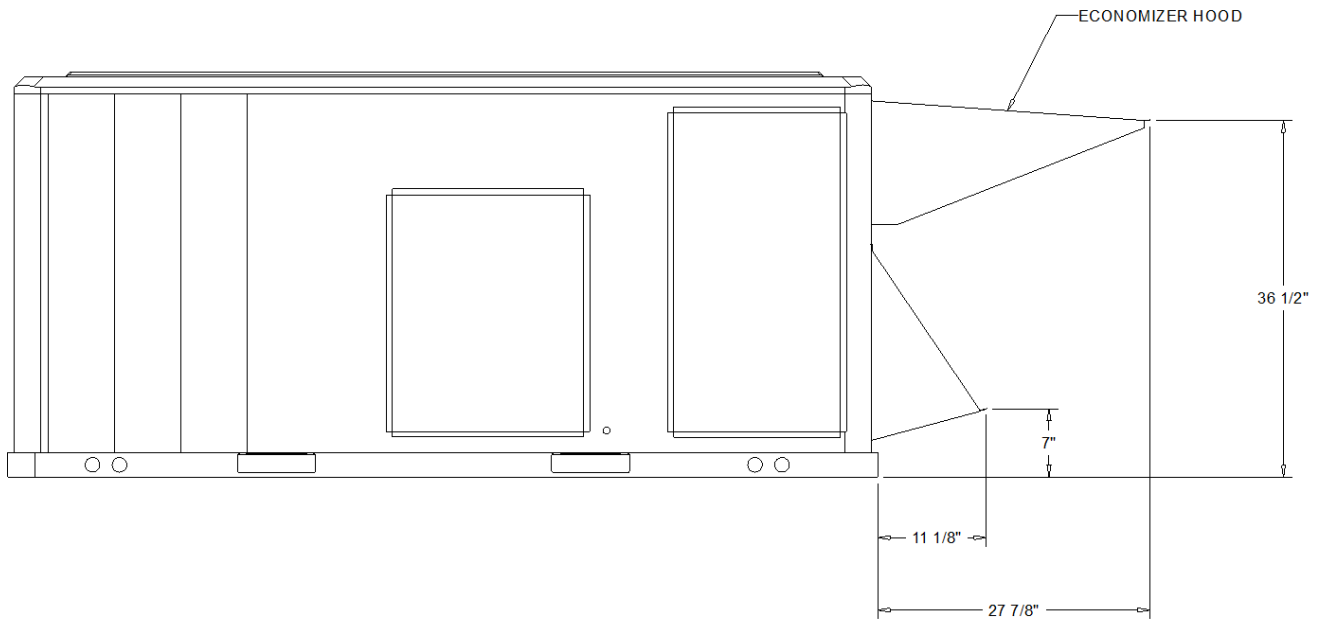
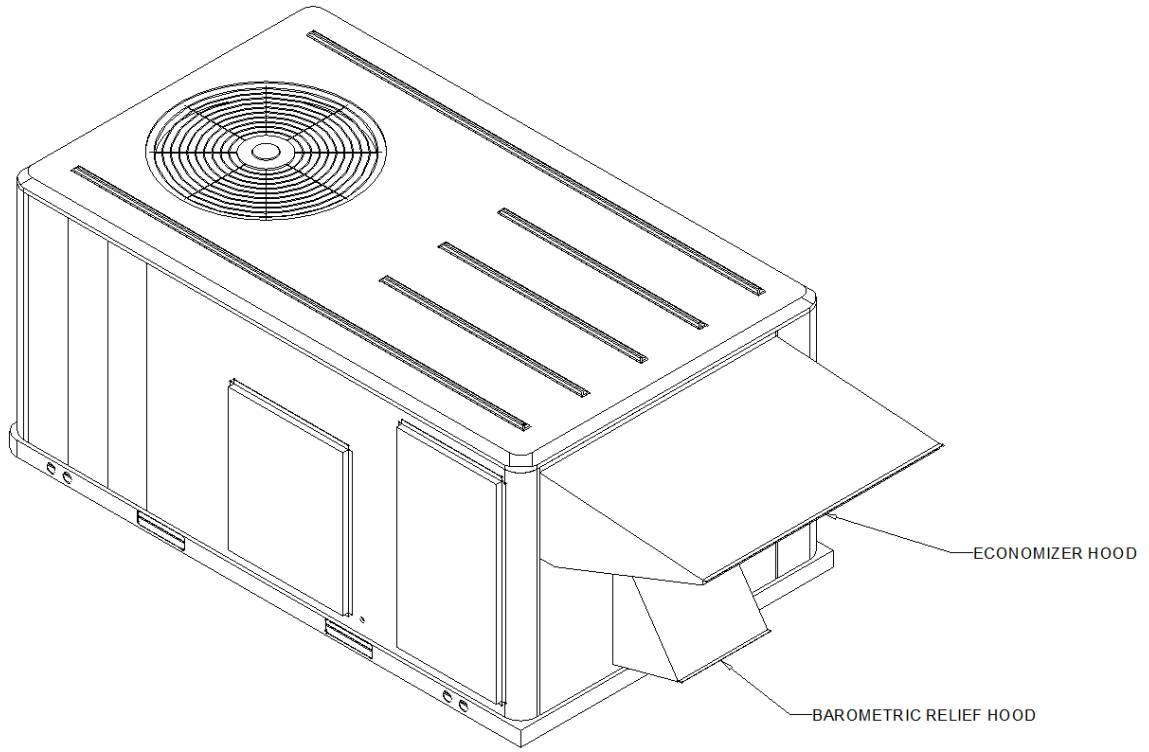

LOW LEAK ECONOMIZER HOOD  
 ACCESSORY

**APPENDIX 5.3:**  
**CADNAA OPERATIONAL NOISE MODEL INPUTS**

This page intentionally left blank

# 12975 - Moreno Valley Trade Center

CadnaA Noise Prediction Model: 15739-02\_Operation2.cna

Date: 22.12.23

Analyst: B. Lawson

## Calculation Configuration

Configuration	
Parameter	Value
<b>General</b>	
Max. Error (dB)	0.00
Max. Search Radius #(Unit,LEN)	2000.01
Min. Dist Src to Rcvr	0.00
<b>Partition</b>	
Raster Factor	0.50
Max. Length of Section #(Unit,LEN)	999.99
Min. Length of Section #(Unit,LEN)	1.01
Min. Length of Section (%)	0.00
Proj. Line Sources	On
Proj. Area Sources	On
<b>Ref. Time</b>	
Daytime Penalty (dB)	0.00
Recr. Time Penalty (dB)	5.00
Night-time Penalty (dB)	10.00
<b>DTM</b>	
Standard Height (m)	0.00
Model of Terrain	Triangulation
<b>Reflection</b>	
max. Order of Reflection	2
Search Radius Src	100.00
Search Radius Rcvr	100.00
Max. Distance Source - Rcvr	1000.00 1000.00
Min. Distance Rcvr - Reflector	1.00 1.00
Min. Distance Source - Reflector	0.10
<b>Industrial (ISO 9613)</b>	
Lateral Diffraction	some Obj
Obst. within Area Src do not shield	On
<b>Screening</b>	
	Incl. Ground Att. over Barrier
	Dz with limit (20/25)
Barrier Coefficients C1,2,3	3.0 20.0 0.0
Temperature #(Unit,TEMP)	10
rel. Humidity (%)	70
Ground Absorption G	0.50
Wind Speed for Dir. #(Unit,SPEED)	3.0
<b>Roads (TNM)</b>	
<b>Railways (FTA/FRA)</b>	
<b>Aircraft (???)</b>	
Strictly acc. to AzB	

## Receiver Noise Levels

Name	M.	ID	Level Lr			Limit. Value			Land Use			Height (ft)	Coordinates		
			Day (dBA)	Night (dBA)	CNEL (dBA)	Day (dBA)	Night (dBA)	CNEL (dBA)	Type	Auto	Noise Type		X (ft)	Y (ft)	Z (ft)
R1		R1	48.8	47.5	54.0	0.0	0.0	0.0	x	Total	5.00	a	6048902.71	2289711.61	5.00
R2		R2	39.2	37.2	43.8	0.0	0.0	0.0	x	Total	5.00	a	6049064.96	2289719.32	5.00
R3		R3	38.7	36.0	42.7	0.0	0.0	0.0	x	Total	5.00	a	6048915.48	2289455.26	5.00

## Point Source(s)

Name	M.	ID	Result. PWL			Lw / Li		Operating Time			Height (ft)	Coordinates			
			Day (dBA)	Evening (dBA)	Night (dBA)	Type	Value (dBA)	norm.	Day (min)	Special (min)		Night (min)	X (ft)	Y (ft)	Z (ft)
SPEAKER1		SPEAKER1	88.8	88.8	88.8	Lw	88.8	300.00	0.00	180.00	1.50	a	6048906.34	2289663.50	1.50
SPEAKER2		SPEAKER2	88.8	88.8	88.8	Lw	88.8	300.00	0.00	180.00	1.50	a	6048897.83	2289679.64	1.50
AC1		AC1	87.2	87.2	87.2	Lw	87.2	675.00	0.00	270.00	3.00	g	6048903.99	2289625.25	17.00
AC2		AC2	87.2	87.2	87.2	Lw	87.2	675.00	0.00	270.00	3.00	g	6048902.01	2289605.72	17.00

## Line Source(s)

Name	M.	ID	Result. PWL			Result. PWL'			Lw / Li		Operating Time			Moving Pt. Src			Height (ft)
			Day (dBA)	Evening (dBA)	Night (dBA)	Day (dBA)	Evening (dBA)	Night (dBA)	Type	Value (dBA)	norm.	Day (min)	Special (min)	Night (min)	Number	Speed (mph)	

Name	ID	Height		Coordinates			
		Begin (ft)	End (ft)	x (ft)	y (ft)	z (ft)	Ground (ft)

## Area Source(s)

Name	M.	ID	Result. PWL			Result. PWL"			Lw / Li			Operating Time			Height (ft)
			Day (dBA)	Evening (dBA)	Night (dBA)	Day (dBA)	Evening (dBA)	Night (dBA)	Type	Value	norm.	Day (min)	Special (min)	Night (min)	

Name	ID	Height		Coordinates			
		Begin (ft)	End (ft)	x (ft)	y (ft)	z (ft)	Ground (ft)

### Building(s)

Name	Sel.	M.	ID	RB	Residents	Absorption	Height (ft)	Coordinates				
								Begin (ft)	x (ft)	y (ft)	z (ft)	Ground (ft)
BUILDING			BUILDING00001	x	0		14.00	a	6048912.59	2289644.22	14.00	0.00
									6048912.59	2289616.45	14.00	0.00
									6048915.20	2289616.27	14.00	0.00
									6048915.20	2289607.25	14.00	0.00
									6048912.94	2289607.25	14.00	0.00
									6048912.77	2289585.20	14.00	0.00
									6048902.17	2289584.85	14.00	0.00
									6048902.17	2289589.02	14.00	0.00
									6048894.88	2289589.02	14.00	0.00
									6048895.06	2289644.05	14.00	0.00

### Ground Absorption(s)

Name	Sel.	M.	ID	G	Coordinates	
					x (ft)	y (ft)

### Contour(s)

Name	Sel.	M.	ID	OnlyPts	Height		Coordinates			
					Begin (ft)	End (ft)	x (ft)	y (ft)	z (ft)	

### Vertical Area Source(s)

Name	ID	Height		Coordinates			
		Begin (ft)	End (ft)	x (ft)	y (ft)	z (ft)	Ground (ft)

### Rail

Name	Sel.	M.	ID	Lw'	Train Class	Correct.	Vmax

### Sound Level Spectra

Name	ID	Type	Oktave Spectrum (dB)											Source			
			Weight.	31.5	63	125	250	500	1000	2000	4000	8000	A	lin			

### Roads

Name	Sel.	M.	ID	Lme			Count Data		exact Count Data						Speed Limit		SCS		Surface		Gradient (%)	Mult. Reflection											
				Day (dBA)	Evening (dBA)	Night (dBA)	DTV	Str.class.	M p (%)			p (%)			Auto (mph)	Truck (mph)	Dist. (dB)	Dstro (dB)	Type	Drefl (dB)		Hbuild (ft)	Dist. (ft)										

### RoadsGeo

Name	Height		Coordinates				Dist (ft)	LSlope (%)
	Begin (ft)	End (ft)	x (ft)	y (ft)	z (ft)	Ground (ft)		