

**CITY OF LA HABRA
PUBLIC WORKS AGREEMENT FOR
MACY STREET REHABILITATION PROJECT
CITY PROJECT NO. 1-R-23**

THIS AGREEMENT (herein "Agreement"), is made and entered into this 19 day of MAY, 2025, and between the **CITY OF LA HABRA**, a municipal corporation (herein "City") and **COPP CONTRACTING, INC.** (herein "Contractor"). The parties hereto agree as follows:

W I T N E S S E T H :

A. WHEREAS, City requires the construction of roadway improvements as set forth more fully in this Agreement.

B. WHEREAS, Contractor represents to City that Contractor is qualified to perform said work and has submitted a proposal to City for the same.

C. WHEREAS, City desires to have Contractor perform said services on the terms and conditions set forth herein.

D. WHEREAS, no official or employee of City has a financial interest, within the provisions of Sections 1090-1092 of the California Government Code, in the subject matter of this Agreement.

NOW, THEREFORE, for and in consideration of the mutual covenants and conditions contained herein and for good and valuable consideration, the receipt and sufficiency of which is acknowledged by both parties, City and Contractor hereby agree as follows:

1.0 DEFINITIONS

1.1 Definitions. As used in this Agreement, the following definitions shall be applicable:

- (a) Contractor. Contractor shall mean COPP CONTRACTING, INC., a California corporation located at 6751 Stanton Avenue, Buena Park, CA 90621.
- (b) City. City shall mean the City of La Habra, a Municipal Corporation and General Law City, located at 110 E. La Habra Blvd, La Habra, California 90631.
- (c) City Council. City Council shall mean the City Council of the City of La Habra.
- (d) Contract Officer shall mean the person designated by the City Administrator or City Engineer of City and shall have the duties set forth in Section 5.2.
- (e) Services. Services shall mean the services to be performed by the Contractor pursuant to this Agreement.
- (f) Satisfactory. Satisfactory shall mean satisfactory to the City Administrator or his/her designee.

2.0 SERVICES OF CONTRACTOR

2.1 Scope of Services. In compliance with all terms and conditions of this Agreement, the Contractor shall provide those services specified in the "Scope of Services" attached hereto as Exhibit "A" and incorporated herein by this reference, which services may be referred to herein as the "services" or "work" hereunder. As a material inducement to the City entering into this Agreement, Contractor represents and warrants that Contractor is a provider of first class work and services and Contractor is experienced in performing the work and services contemplated herein and, in light of such status and experience, Contractor covenants that it shall follow the highest professional standards in performing the work and services required hereunder and that all materials will be of good quality, fit for the purpose intended.

2.2 Documents Included in Contract. This contract consists of this Agreement and any Exhibits, which are incorporated herein by this reference. In the event of an inconsistency, the terms of this Agreement shall govern.

2.3 Compliance with Law. All services rendered hereunder shall be provided in accordance with all ordinances, resolutions, statutes, rules, and regulations of the City and any Federal, State or local governmental agency having jurisdiction in effect at the time service is rendered, including but not limited to, the claims procedure set forth in Public Contract Code Section 9204, a summary of which is attached to this agreement as Exhibit "D."

2.4 Licenses, Permits, Fees and Assessments. Contractor shall obtain at its sole cost and expense such licenses, permits and approvals as may be required by law for the performance of the services required by this Agreement, including registration with the Department of Industrial Relations of the State of California as required by Labor Code Section 1725.5 before commencing performance under this Agreement. Contractor shall have the sole obligation to pay for any fees, assessments and taxes, plus applicable penalties and interest, which may be imposed by law and arise from or are necessary for the Contractor's performance of the services required by this Agreement, and shall indemnify, defend and hold harmless City against any such fees, assessments, taxes penalties or interest levied, assessed or imposed against City hereunder. Contractor shall be responsible for all subcontractors' compliance with this Section 2.4.

2.5 Familiarity with Work. By executing this Contract, Contractor warrants that Contractor (a) has thoroughly investigated and considered the scope of services to be performed, (b) has carefully considered how the services should be performed, and (c) fully understands the facilities, difficulties and restrictions attending performance of the services under this Agreement. If the services involve work upon any site, Contractor warrants that Contractor has or will investigate the site and is or will be fully acquainted with the conditions there existing, prior to commencement of services hereunder. Should Contractor discover any latent or unknown conditions, which will materially affect the performance of the services hereunder, Contractor shall immediately inform the City of such fact and shall not proceed except at Contractor's risk until written instructions are received from the Contract Officer.

2.6 Standard of Performance. Contractor, its subcontractors and their employees, in the performance of Contractor's work under this Agreement shall be responsible for exercising the degree of skill and care required by customarily accepted good professional practices and procedures used in the Contractor's field.

Any costs for failure to meet the foregoing standard or to correct otherwise defective work that requires re-performance of the work, shall be borne in total by the Contractor and not by the City. The failure of a

project to achieve the performance goals and objectives stated in this Agreement is not a basis for requesting re-performance unless the work conducted by Contractor and/or its subcontractors is deemed by the City to have failed the foregoing standard of performance.

In the event Contractor fails to perform in accordance with the above standard:

1. Contractor will re-perform, at its own expense, any task which was not performed to the reasonable satisfaction of City. Any work re-performed pursuant to this paragraph shall be completed within the time limitations originally set forth for the specific task involved. Contractor shall work any overtime required to meet the deadline for the task at no additional cost to the City;
2. The City shall provide a new schedule for the re-performance of any task pursuant to this paragraph in the event that re-performance of a task within the original time limitations is not feasible; and
3. The City shall have the option to direct Contractor not to re-perform any task which was not performed to the reasonable satisfaction of the City Project Manager pursuant to application of (1) and (2) above. In the event the City directs Contractor not to re-perform a task, the City shall negotiate a reasonable settlement for satisfactory work performed. No previous payment shall be considered a waiver of the City's right to reimbursement.

Nothing contained in this section is intended to limit any of the rights or remedies which the City may have under law.

2.7 Care of Work. The Contractor shall adopt reasonable methods during the life of the Agreement to furnish continuous protection to the work, and the equipment, materials, papers, documents, plans, studies and/or other components thereof to prevent losses or damages, and shall be responsible for all such damages, to persons or property, until acceptance of the work by City, except such losses or damages as may be caused by City's own negligence.

2.8 Further Responsibilities of Parties. Both parties agree to use reasonable care and diligence to perform their respective obligations under this Agreement. Both parties agree to act in good faith to execute all instruments, prepare all documents and take all actions as may be reasonably necessary to carry out the purposes of this Agreement. Unless hereafter specified, neither party shall be responsible for the service of the other. Contractor shall require all subcontractors to comply with the provisions of this agreement.

2.9 Additional Services. City shall have the right at any time during the performance of the services, without invalidating this Agreement, to order extra work beyond that specified in the Scope of Services or make changes by altering, adding to or deducting from said work. No such extra work may be undertaken unless a written change order is first given by the Contract Officer to the Contractor, incorporating therein any adjustment in (i) the Contract Sum as set forth in Section 3.1, and/or (ii) the time to perform this Agreement, which said adjustments are subject to the written approval of the Contractor. Any increase in compensation of twenty five percent (25%) or less of the Contract Sum, or in the time to perform of one hundred eighty (180) days or less may be approved by the Contract Officer. Any increases, taken either separately or cumulatively, that result in the Contract Sum exceeding \$25,000 must be approved by the City Council. It is expressly understood by Contractor that the provisions of this Section shall not apply to services specifically set forth in the Scope of Services or reasonably contemplated therein. Contractor hereby acknowledges that it accepts the risk that the services to be provided pursuant to the Scope of Services may be more costly or time consuming than Contractor anticipates and that Contractor shall not be entitled to additional compensation therefore.

2.10 Prevailing Wage Laws. Contractor represents and warrants that it is registered with the Department of Industrial Relations pursuant to SB 854 and Labor Code 1725.5. Contractor shall ensure that its subcontractors comply with said requirements. In accordance with Labor Code Section 1770 et seq., the Director of the Department of Industrial Relations of the State of California has ascertained a general prevailing rate of wages, which is the minimum amount, which shall be paid to all workers employed to perform the work pursuant to this Agreement. A copy of the general prevailing wage rate determination is on file in the Office of the City Clerk and is hereby incorporated by reference into this Agreement. In accordance with the provisions of Labor Code Section 1810 et seq., eight (8) hours is the legal working day. Contractor must forfeit to the City Twenty Five Dollars (\$25.00) a day for each worker who works in excess of the minimum working hours when Contractor does not pay overtime. Contractor is required to post a copy of such wage rates at all times at the contract site. The statutory penalties for failure to pay prevailing wage or to comply with State wage and hour laws will be enforced. Contractor also shall comply with State law requirements to maintain payroll records and shall provide for certified records and inspection of records as required by California Labor Code Section 1770 et. seq., including Section 1776. Contractor shall comply with all statutory requirements relating to the employment of apprentices.

3.0 COMPENSATION

3.1 Contract Sum. For the services rendered pursuant to this Agreement, the Contractor shall be compensated as specified herein, but not exceeding the maximum contract amount of three hundred ninety-one thousand three hundred eleven Dollars and seventy-eight Cents (\$391,311.78) (herein "Contract Sum"), except as provided in Section 2.9. The Contract Sum shall include the attendance of Contractor at all project meetings reasonably deemed necessary by the City; Contractor shall not be entitled to any additional compensation for attending said meetings.

3.2 Progress Payments. Prior to the first day of the month, during the progress of the work, commencing on the day and month specified in the Agreement, Contractor shall submit to the Contract Officer a complete itemized statement of all labor and materials incorporated into the work during the preceding month and the portion of the contract sum applicable thereto. Upon approval in writing by the Contract Officer, payment shall be made in thirty (30) days. City shall pay Contractor a sum based upon ninety-five percent (95%) of the contract price apportionment of the labor and materials incorporated into the work under the contract during the month covered by said statement. The remaining five percent (5%) thereof shall be retained as performance security. Refer to Section 8.4 of this Agreement for retention of funds.

4.0 PERFORMANCE SCHEDULE

4.1 Time of Essence. Time is of the essence in the performance of this Agreement.

4.2 Schedule of Performance. Contractor shall commence the services pursuant to this Agreement upon receipt of a written notice to proceed and shall perform all services within the time period(s) established in Exhibit "A", and incorporated herein by this reference. When requested by the Contractor, extensions to the time period(s) specified in the Scope of Services may be approved in writing by the Contract Officer.

4.3 Force Majeure. The time period(s) specified in the Scope of Services for performance of the services rendered pursuant to this Agreement shall be extended because of any delays due to unforeseeable causes beyond the control and without the fault or negligence of the Contractor, including, but not restricted to, acts of God or of the public enemy, unusually severe weather, fires, earthquakes, floods, epidemics, quarantine restrictions, riots, strikes, freight embargoes, wars, litigation, and/or acts of any governmental agency, including

the City, if the Contractor shall within ten (10) days of the commencement of such delay notify the Contract Officer in writing of the causes for the delay. The Contract Officer shall ascertain the facts and the extent of delay, and extend the time for performing the services for the period of the enforced delay when and if in the judgment of the Contract Officer such delay is justified. The Contract Officer's determination shall be final and conclusive upon the parties to this Agreement.

4.4 Term. Unless earlier terminated in accordance with Section 8.9 of this Agreement, this Agreement shall continue in full force and effect until final approval and acceptance of the project by the Contract Officer. Notwithstanding the foregoing, this Agreement shall terminate no later than June 30, 2027, unless the parties mutually agree in writing to extend the term.

5.0 COORDINATION OF WORK

5.1 Representative of Contractor. The following principals of Contractor are hereby designated as being the principals and representatives of Contractor authorized to act in its behalf with respect to the work specified herein and make all decisions in connection therewith:

Ezekiel A. Copp, President
6751 Stanton Avenue
Buena Park, CA 90621

It is expressly understood that the experience, knowledge, capability and reputation of the foregoing principals were a substantial inducement for City to enter into this Agreement. Therefore, the foregoing principals shall be responsible during the term of this Agreement for directing all activities of Contractor and devoting sufficient time to personally supervise the services hereunder. For purposes of this Agreement, the foregoing principals may not be replaced nor may their responsibilities be substantially reduced by Contractor without the express written approval of City.

5.2 Contract Officer. The Contract Officer shall be such person as may be designated by the City Administrator or City Engineer of City. It shall be the Contractor's responsibility to assure that the Contract Officer is kept informed of the progress of the performance of the services and the Contractor shall refer any decisions that must be made by City to the Contract Officer. Unless otherwise specified herein, any approval of City required hereunder shall mean the approval of the Contract Officer. The Contract Officer shall have authority to sign all documents on behalf of the City required hereunder to carry out the terms of this Agreement.

5.3 Prohibition Against Assignment. The experience, knowledge, capability and reputation of Contractor, its principals and employees were a substantial inducement for the City to enter into this Agreement. Neither this Agreement nor any interest herein may be transferred, assigned, conveyed, hypothecated or encumbered voluntarily or by operation of law, whether for the benefit of creditors or otherwise, without the prior written approval of City. Transfers restricted hereunder shall include the transfer to any person or group of persons acting in concert of more than twenty five percent (25%) of the present ownership and/or control of Contractor, taking all transfers into account on a cumulative basis. In the event of any such unapproved transfer, including any bankruptcy proceeding, this Agreement shall be void. No approved transfer shall release the Contractor or any surety of Contractor of any liability hereunder without the express consent of City.

5.4 Independent Contractor. Neither the City nor any of its employees shall have any control over the manner, mode or means by which Contractor, its subcontractors, agents or employees, performs the services required herein, except as otherwise set forth herein. City shall have no voice in the

selection, discharge, supervision or control of Contractor's employees, subcontractors, servants, representatives or agents, or in fixing their number, compensation or hours of service. Contractor shall perform all services required herein as an independent contractor of City and shall remain at all times as to City a wholly independent contractor with only such obligations as are consistent with that role. Contractor shall not at any time or in any manner represent that it or any of its subcontractors, agents or employees are agents or employees of City. City shall not in any way or for any purpose become or be deemed to be a partner of Contractor in its business or otherwise or a joint venture or a member of any joint enterprise with Contractor.

5.5 Identity of Persons Performing Work. Contractor represents that it employs or will employ at its own expense all personnel required for the satisfactory performance of any and all tasks and services set forth herein. Contractor represents that the tasks and services required herein will be performed by Contractor or under its direct supervision, and that all personnel engaged in such work shall be fully qualified and shall be authorized and permitted under applicable State and local law to perform such tasks and services.

5.6 Utility Relocation. City is responsible for removal, relocation, or protection of existing main or trunkline utilities to the extent such utilities were not identified in the invitation for bids or specifications. City shall reimburse contractor for any costs incurred in locating, repairing damage not caused by contractor and removing or relocating such unidentified utility facilities, including equipment idled during such work. Contractor shall not be assessed liquidated damages for delay arising from the removal or relocation of such unidentified utility facilities.

5.7 Trenches or Excavations. Pursuant to California Public Contract Code Section 7104, in the event the work included in this Agreement requires excavations more than four (4) feet in depth, the following shall apply.

- (a) Contractor shall promptly, and before the following conditions are disturbed, notify City, in writing, of any: (1) material that Contractor believes may be material that is hazardous waste, as defined in Section 25117 of the Health and Safety Code, that is required to be removed to a Class I, Class II, or Class III disposal site in accordance with provisions of existing law; (2) Subsurface or latent physical conditions at the site different from those indicated; or (3) Unknown physical conditions at the site of any unusual nature, different materially from those ordinarily encountered and generally recognized as inherent in work of the character provided for in the contract.
- (b) City shall promptly investigate the conditions, and if it finds that the conditions do materially so differ, or do involve hazardous waste, and cause a decrease or increase in Contractor's cost of, or the time required for, performance of any part of the work shall issue a change order per Section 2.9 of this Agreement.
- (c) That, in the event that a dispute arises between City and Contractor whether the conditions materially differ, or involve hazardous waste, or cause a decrease or increase in Contractor's cost of, or time required for, performance of any part of the work, Contractor shall not be excused from any scheduled completion date provided for by the contract, but shall proceed with all work to be performed under the contract. Contractor shall retain any and all rights provided either by contract or by law, which pertain to the resolution of disputes and protests between the contracting parties.

6.0 INSURANCE, INDEMNIFICATION AND BONDS

6.1 Insurance. The Contractor and all subcontractors, if any, shall procure and maintain, at its sole cost and expense, in a form and content satisfactory to City, during the entire term of this Agreement including any extension thereof, insurance as set forth in Exhibit "B" attached hereto and incorporated herein by this reference.

Conditions:

In accordance with Public Contract Code Section 20170, the insurance of surety companies who provide or issue the policy shall have been admitted to do business in the State of California with a credit rating of A- or better.

This insurance shall not be canceled, limited in scope or coverage or non-renewed until after thirty (30) days prior written notice has been given to the Public Works Director, City of La Habra, 110 E. La Habra Blvd., La Habra, California 90631.

Any insurance maintained by the City of La Habra shall apply in excess of and not combined with insurance provided by this policy.

The City of La Habra, its officers, employees, representatives, attorneys, and volunteers shall be named as additional named insureds.

Prior to commencement of any work under this contract, Contractor shall deliver to the City insurance endorsements confirming the existence of the insurance required by this contract, and including the applicable clauses referenced above.

Such endorsements shall be signed by an authorized representative of the insurance company and shall include the signator's company affiliation and title. Should it be deemed necessary by the City, it shall be Contractor's responsibility to see that the City receives documentation, acceptable to the City, which sustains that the individual signing said endorsements is indeed authorized to do so by the insurance company.

If the Contractor fails to maintain the aforementioned insurance, or secure and maintain the aforementioned endorsement, the City may obtain such insurance, and deduct and retain the amount of the premiums for such insurance from any sums due under the agreement. However, procuring of said insurance by the City is an alternative to other remedies the City may have, and is not the exclusive remedy for failure of Contractor to maintain said insurance or secure said endorsement. In addition to any other remedies the City may have upon Contractor's failure to provide and maintain any insurance or policy endorsements to the extent and within the time herein required, the City shall have the right to order Contractor to stop work hereunder, and/or withhold any payment(s) which became due to Contractor hereunder until Contractor demonstrates compliance with the requirements hereof.

Nothing herein contained shall be construed as limiting in any way the extent to which Contractor may be held responsible for payments of damages to persons or property resulting from Contractor's or its subcontractor's performance of the work covered under this agreement.

Each contract between the Contractor and any subcontractor shall require the subcontractor to maintain the same policies of insurance that the Contractor is required to maintain pursuant to this Section 6.1 and Exhibit "B".

6.2 Certificates of Insurance. Contractor shall provide to City certificates of insurance showing the insurance coverages and required endorsements described above, in a form and content approved by City, prior to performing any services under this Agreement. The certificates of insurance and endorsements shall be attached to this Agreement as Exhibit "C", and are incorporated herein by this reference.

6.3 Indemnification. Contractor shall defend, indemnify, hold free and harmless the City of La Habra, its elected and appointed officials, officers, agents and employees, at Contractor's sole expense, from and against any and all actions, suits, claims, damages to persons or property, losses, costs, penalties, obligations, errors, omissions or liabilities, (herein "claims or liabilities") that may be asserted or claimed by any person, firm or entity arising or alleged to arise out of or in connection with the performance of the work, operations or activities of Contractor, its agents, employees, subcontractors, or invitees, provided for herein, or arising or alleged to arise from the negligent acts or omissions of Contractor hereunder, or arising or alleged to arise from Contractor's performance of or failure to perform any term, provision, covenant or condition of this Agreement.

- (a) Contractor will defend any action or actions filed in connection with any of said claims or liabilities and will pay all costs and expenses, including legal costs and attorneys' fees incurred in connection therewith.
- (b) Contractor will promptly pay any judgment rendered against the City, its officers, agents or employees for any such claims or liabilities arising or alleged to arise out of or in connection with Contractor's (or its agents', employees', subcontractors' or invitees') negligent performance of or failure to perform such work, operations or activities hereunder; and Contractor agrees to save and hold the City, its officers, agents, and employees harmless therefrom.
- (c) In the event the City, its officers, agents or employees is made a party to any action or proceeding filed or prosecuted against Contractor for such damages or other claims arising or alleged to arise out of or in connection with the performance of or failure to perform the work, operation or activities of Contractor hereunder, Contractor shall pay to the City, its officers, agents or employees, any and all costs and expenses incurred by the City, its officers, agents or employees in such action or proceeding, including but not limited to, legal costs and attorneys' fees for counsel selected by City.
- (d) Contractor's duty to defend and indemnify as set out in this Section 6.3 shall include any claims, liabilities, obligations, losses, demands, actions, penalties, suits, costs, expenses or damages or injury to persons or property arising or alleged to arise from, in connection with, as a consequence of or pursuant to any state or federal law or regulation regarding hazardous substances, including but not limited to the Federal Insecticide, Fungicide and Rodenticide Act ("FIFRA"), Comprehensive Environmental Response, Compensation and Liability Act of 1980 ("CERCLA"), Resource Conservation and Recovery Act of 1976 ("RCRA"), the Hazardous and Solid Waste Amendments of 1984, the Hazardous Material Transportation Act, the Toxic Substances control Act, the Clean Air Act, the Clean Water Act, the California Hazardous Substance Account Act, the California Hazardous Waste Control Law or the Porter-Cologne Water Quality Control Act, as any of those statutes may be amended from time to time.

Notwithstanding the foregoing, Contractor shall not be liable for the defense or indemnification of the City for claims, actions, complaints or suits arising out of the sole active negligence or willful misconduct of the City.

The Contractor's indemnification obligations pursuant to this Section 6.3 shall survive the termination of this Agreement. Contractor shall require the same indemnification from all subcontractors.

6.4 Labor and Materials and Performance Bonds. Concurrently with execution of this Agreement, Contractor shall deliver to City a labor and materials bond and a performance bond each in the sum of the amount of this Agreement, in the forms provided by the City Clerk, which secures the faithful performance of this Agreement. The bonds shall contain the original notarized signature of an authorized officer of the surety and affixed thereto shall be a certified and current copy of his power of attorney. The bonds shall be unconditional and remain in force during the entire term of the Agreement and shall be null and void only if the Contractor promptly and faithfully performs all terms and conditions of this Agreement.

6.5 Sufficiency of Insurer or Surety. Insurance required by this Agreement shall be satisfactory only if issued by companies qualified to do business in California, rated "A" or better in the most recent edition of Best Rating Guide, The Key Rating Guide or in the Federal Register, and only if they are of a financial category Class VII or better, unless such requirements are waived by the Risk Manager of the City due to unique circumstances.

6.6 Substitution of Securities. Pursuant to California Public Contract Code Section 22300, substitution of eligible equivalent securities for any monies withheld to ensure performance under the contract for the work to be performed will be permitted at the request and expense of the successful bidder.

7.0 RECORDS AND REPORTS

7.1 Reports. Contractor shall periodically prepare and submit to the Contract Officer such reports concerning the performance of the services required by this Agreement as the Contract Officer shall require. Contractor hereby acknowledges that the City is greatly concerned about the cost of work and services to be performed pursuant to this Agreement. For this reason, Contractor agrees that if Contractor becomes aware of any facts, circumstances, techniques, or events that may or will materially increase or decrease the cost of the work or services contemplated herein or, if Contractor is providing design services, the cost of the project being designed, Contractor shall promptly notify the Contract Officer of said fact, circumstance, technique or event and the estimated increased or decreased cost related thereto and, if Contractor is providing design services, the estimated increased or decreased cost estimate for the project being designed.

7.2 Records. Contractor shall keep, and require subcontractors to keep, such books and records (including but not limited to payroll records as required herein) as shall be necessary to perform the services required by this Agreement and enable the Contract Officer to evaluate the performance of such services. The Contract Officer shall have full and free access to such books and records at all times during normal business hours of City, including the right to inspect, copy, audit and make records and transcripts from such records. Such records shall be maintained for a period of three (3) years following completion of the services hereunder, and the City shall have access to such records in the event any audit is required.

7.3 Ownership of Documents. All drawings, specifications, reports, records, documents and other materials prepared by Contractor, its employees, subcontractors and agents in the performance of this Agreement shall be the property of City and shall be delivered to City upon request of the Contract Officer or upon the termination of this Agreement, and Contractor shall have no claim for further employment or additional compensation as a result of the exercise by City of its full rights of ownership of the documents and materials hereunder. Contractor may retain copies of such documents for its own use. Contractor shall have an unrestricted right to use the concepts embodied therein. All subcontractors shall

provide for assignment to City of any documents or materials prepared by them, and in the event Contractor fails to secure such assignment, Contractor shall indemnify City for all damages resulting therefrom.

7.4 Public Records Act Disclosure. Contractor has been advised and is aware that this Agreement and all reports, documents, information and data, including, but not limited to, computer tapes, discs or files furnished or prepared by Contractor, or any of its subcontractors, pursuant to this Agreement and provided to City may be subject to public disclosure as required by the California Public Records Act (California Government Code Section 6250 *et seq.*). Exceptions to public disclosure may be those documents or information that qualify as trade secrets, as that term is defined in the California Government Code Section 6254.7, and of which Contractor informs City of such trade secret. The City will endeavor to maintain as confidential all information obtained by it that is designated as a trade secret. The City shall not, in any way, be liable or responsible for the disclosure of any trade secret including, without limitation, those records so marked if disclosure is deemed to be required by law or by order of the Court.

8.0 GENERAL PROVISIONS

8.1 Governing Law. This Agreement shall be construed and interpreted both as to validity and to performance of the parties in accordance with the laws of the State of California. Legal actions concerning any dispute, claim or matter arising out of or in relation to this Agreement shall be instituted in the Superior Court of the County of Orange, State of California, or any other appropriate court in such county, and Contractor covenants and agrees to submit to the personal jurisdiction of such court in the event of such action.

8.2 Representatives. The City Administrator or his or her designee shall be the representative of City for purposes of this Agreement and may issue all consents, approvals, directives and agreements on behalf of the City, called for by this Agreement, except as otherwise expressly provided in this Agreement.

The Principal set forth in Section 5.1 above shall be the representative for Contractor for purposes of this Agreement, and shall be authorized to issue all consents, approvals, directives and agreements on behalf of Contractor called for by this Agreement, except as otherwise expressly provided in this Agreement.

8.3 Disputes. In the event either party fails to perform its obligations hereunder, the nondefaulting party shall provide the defaulting party written notice of such default. The defaulting party shall have ten (10) days to cure the default; provided that, if the default is not reasonably susceptible to being cured within said ten (10) day period, the defaulting party shall have a reasonable time to cure the default, not to exceed a maximum of thirty (30) days, so long as the defaulting party commences to cure such default within ten (10) days of service of such notice and diligently prosecutes the cure to completion; provided further that if the default is an immediate danger to the health, safety and general welfare, the defaulting party shall take such immediate action as may be necessary. Notwithstanding the foregoing, the nondefaulting party may, in its sole and absolute discretion, grant a longer cure period. Should the defaulting party fail to cure the default within the time period provided in this Section, the nondefaulting party shall have the right, in addition to any other rights the nondefaulting party may have at law or in equity, to terminate this Agreement. Compliance with the provisions of this Section 8.3 shall be a condition precedent to bringing any legal action, and such compliance shall not be a waiver of any party's right to take legal action in the event that the dispute is not cured.

8.4 Retention of Funds. Progress payments shall be made in accordance with the provisions of Section 3.2 of this Agreement. In accordance with said section, City shall pay Contractor a sum based upon ninety-five percent (95%) of the contract price apportionment of the labor and materials incorporated into

the work under the contract during the month covered by said statement. The remaining five percent (5%) thereof shall be retained as performance security to be paid to the Contractor within sixty (60) days after final acceptance of the work by the City Council, after Contractor shall have furnished City with a release of all undisputed contract amounts if required by City. In the event there are any claims specifically excluded by Contractor from the operation of the release, the City may retain proceeds (per Public Contract Code 7107) of up to 150% of the amount in dispute. City's failure to deduct or withhold shall not affect Contractor's obligations hereunder.

8.5 Waiver. No delay or omission in the exercise of any right or remedy by a nondefaulting party on any default shall impair such right or remedy or be construed as a waiver. A party's consent to or approval of any act by the other party requiring the party's consent or approval shall not be deemed to waive or render unnecessary the other party's consent to or approval of any subsequent act. Any waiver by either party of any default must be in writing and shall not be a waiver of any other default concerning the same or any other provision of this Agreement.

8.6 Rights and Remedies. Rights and Remedies are cumulative except with respect to rights and remedies expressly declared to be exclusive in this Agreement, the rights and remedies of the parties are cumulative and the exercise by either party of one or more of such rights or remedies shall not preclude the exercise by it, at the same or different times, of any other rights or remedies for the same default or any other default by the other party.

8.7 Legal Action. In addition to any other rights or remedies, either party may take legal action, in law or in equity, to cure, correct or remedy any default, to recover damages for any default, to compel specific performance of this Agreement, to obtain declaratory or injunctive relief, or to obtain any other remedy consistent with the purposes of this Agreement.

8.8 Liquidated Damages. Since the determination of actual damages for any delay in performance of this Agreement would be extremely difficult or impractical to determine in the event of a breach of this Agreement, the Contractor and its sureties shall be liable for and shall pay to the City Five Hundred Dollars (\$500.00) as liquidated damages for each working day of delay in the performance of any service required hereunder, as specified in the Scope of Services (Exhibit A). The City may withhold from any monies payable on account of services performed by the Contractor any accrued liquidated damages.

8.9 Termination for Default of Contractor. If termination is due to the failure of the Contractor to fulfill its obligations under this Agreement, Contractor shall vacate any City owned property which Contractor is permitted to occupy hereunder and City may, after compliance with the provisions of Section 8.3, take over the work and prosecute the same to completion by contract or otherwise, and the Contractor shall be liable to the extent that the total cost for completion of the services required hereunder exceeds the compensation herein stipulated (provided that the City shall use reasonable efforts to mitigate such damages), and City may withhold any payments to the Contractor for the purpose of setoff or partial payment of the amounts owed the City as previously stated.

8.10 Notice. Any notice, demand, request, document, consent, approval, or communication either party desires or is required to give to the other party or any other person shall be in writing and shall be deemed to be given when served personally or deposited in the US Mail, prepaid, first-class mail, return receipt requested, addressed as follows:

To City: City of La Habra
110 E. La Habra Blvd
La Habra, California 90631
Attn.: Albert Mendoza

To Contractor:

Ezekiel A. Copp
6751 Stanton Avenue
Buena Park, CA 90621

8.11 Non-liability of City Officers and Employees. No officer or employee of the City shall be personally liable to the Contractor, or any successor in interest, in the event of any default or breach by the City or for any amount which may become due to the Contractor or to its successor, or for breach of any obligation of the terms of this Agreement.

8.12 Conflict of Interest. The Contractor warrants that it has not paid or given and will not pay or give any third party any money or other consideration for obtaining this Agreement.

Contractor and its officers, employees, associates and subcontractors, if any, will comply with all conflict of interest statutes of the State of California applicable to Contractor's services under this agreement, including, but not limited to, the Political Reform Act (Government Code Sections 81000, *et seq.*) and Government Code Section 1090. During the term of this Agreement, Contractor and its officers, employees, associates and subcontractor shall not, without the prior written approval of the City Representative, perform work for another person or entity for whom Contractor is not currently performing work that would require Contractor or one of its officers, employees, associates or subcontractors to abstain from a decision under this Agreement pursuant to a conflict of interest statute.

8.13 Covenant Against Discrimination. Contractor covenants that, by and for itself, its heirs, executors, assigns, and all persons claiming under or through them, that there shall be no discrimination against or segregation of, any person or group of persons on account of race, color, creed, religion, sex, marital status, national origin, or ancestry in the performance of this Agreement. To the extent required by law, contractor shall take affirmative action to insure that applicants are employed and that employees are treated during employment without regard to their race, color, creed, religion, sex, marital status, national origin, or ancestry.

8.14 Interpretation. The terms of this Agreement shall be construed in accordance with the meaning of the language used and shall not be construed for or against either party by reason of the authorship of this Agreement or any other rule of construction which might otherwise apply.

8.15 Severability. In the event that any one or more of the phrases, sentences, clauses, paragraphs, or sections contained in this Agreement shall be declared invalid or unenforceable by a valid judgment or decree of a court of competent jurisdiction, such invalidity or unenforceability shall not affect any of the remaining phrases, sentences, clauses, paragraphs, or sections of this Agreement which are hereby declared as severable and shall be interpreted to carry out the intent of the parties hereunder unless the invalid provision is so material that its invalidity deprives either party of the basic benefit of their bargain or renders this Agreement meaningless.

8.16 [reserved]

8.17 Unfair Business Practices Claims. In entering into a public works contract or a subcontract to supply goods, services or materials pursuant to a public works contract, the contractor or subcontractor offers and agrees to assign to the awarding body all rights, title, and interest in and to all causes of action it may have under Section 4 of the Clayton Act (15 U.S.C. Sec. 15) or under the Cartwright Act (Chapter 2, (commencing with Section 16700) of Part 2 of Division 7 of the Business and Professions

Code), arising from purchases of goods, services or materials pursuant to the public works contract or the subcontract. This assignment shall be made and become effective at the time the awarding body renders final payment to the contractor without further acknowledgment by the parties. (Sec. 7103.5, California Public Contract Code).

8.18 Corporate Authority. The persons executing this Agreement on behalf of the parties hereto warrant that (i) such party is duly organized and existing, (ii) they are duly authorized to execute and deliver this Agreement on behalf of said party, (iii) by so executing this Agreement, such party is formally bound to the provisions of this Agreement, and (iv) the entering into this Agreement does not violate any provision of any other Agreement to which said party is bound.

8.19 PERS Eligibility Indemnification. In the event that Contractor or any employee, agent, or subcontractor of Contractor providing services under this Agreement claims or is determined by a court of competent jurisdiction or the California Public Employees Retirement System (PERS) to be eligible for enrollment in PERS as an employee of the City, Contractor shall indemnify, defend, and hold harmless City for the payment of any employee and/or employer contributions for PERS benefits on behalf of Contractor or its employees, agents, or subcontractors, as well as for the payment of any penalties and interest on such contributions, which would otherwise be the responsibility of City.

Notwithstanding any other agency, state or federal policy, rule, regulation, law or ordinance to the contrary, Contractor and any of its employees, agents, and subcontractors providing service under this Agreement shall not qualify for or become entitled to, and hereby agree to waive any claims to, any compensation, benefit, or any incident of employment by City, including but not limited to eligibility to enroll in PERS as an employee of City and entitlement to any contribution to be paid by City for employer contribution and/or employee contributions for PERS benefits.

8.20 Cooperation. In the event any claim or action is brought against City relating to Contractor's performance or services rendered under this Agreement, Contractor shall render any reasonable assistance and cooperation which City might require.

8.21 Legal Responsibilities. The Contractor shall keep itself informed of City, State, and Federal laws, ordinances and regulations, which may in any manner affect the performance of its services pursuant to this Agreement. The Contractor shall at all times observe and comply with all such laws, ordinances and regulations. Neither the City, nor its officers, agents, or employees shall be liable at law or in equity as a result of the Contractor's failure to comply with this section.

8.22 Termination for Convenience. The City may terminate this Agreement without cause for convenience of the City upon giving contractor 30 days prior written notice of termination of the Agreement. Upon receipt of the notice of termination the Contractor shall cease all further work pursuant to the Agreement. Upon such termination by the City the Contractor shall not be entitled to any other remedies, claims, actions, profits, or damages except as provided in this paragraph. Upon the receipt of such notice of termination Contractor shall be entitled to the following compensation:

1. The contract value of the work completed to and including the date of receipt of the notice of termination, less the amount of progress payments received by contractor.

2. Actual move-off costs including labor, rental fees, equipment transportation costs, the costs of maintaining on-site construction office for supervising the mover-off.

3. The cost of materials custom made for this Agreement which cannot be used by the Contractor in the normal course of his business, and which have not been paid for by City in progress payments.

4. All costs shall not include any markups as might otherwise be allowed by any plans or specifications which were a part of the Agreement.

The provisions of this paragraph shall supersede any other provision of the Agreement or any provision of any plans, specification, addendums or other documents which are or may become a part of this Agreement. City and Contractor agree that the provisions of this paragraph are a substantive part of the consideration for this Agreement.

8.23 Responsibility for Errors. Contractor shall be responsible for its work and results under this Agreement. Contractor, when requested, shall furnish clarification and/or explanation as may be required by the City's representative, regarding any services rendered under this Agreement at no additional cost to City. In the event that an error or omission attributable to Contractor occurs, then Contractor shall, at no cost to City, provide all necessary design drawings, estimates and other Contractor professional services necessary to rectify and correct the matter to the sole satisfaction of City and to participate in any meeting required with regard to the correction.

8.24 Order of Precedence. In the event of an inconsistency in this Agreement and any of the attached Exhibits, the terms set forth in this Agreement shall prevail. If, and to the extent this Agreement incorporates by reference any provision of any document, such provision shall be deemed a part of this Agreement. Nevertheless, if there is any conflict among the terms and conditions of this Agreement and those of any such provision or provisions so incorporated by reference, this Agreement shall govern over the document referenced.

8.25 Costs. Each party shall bear its own costs and fees incurred in the preparation and negotiation of this Agreement and in the performance of its obligations hereunder except as expressly provided herein.

8.26 No Third Party Beneficiary Rights. This Agreement is entered into for the sole benefit of City and Contractor and no other parties are intended to be direct or incidental beneficiaries of this Agreement and no third party shall have any right in, under or to this Agreement.

8.27 Headings. Paragraphs and subparagraph headings contained in this Agreement are included solely for convenience and are not intended to modify, explain or to be a full or accurate description of the content thereof and shall not in any way affect the meaning or interpretation of this Agreement.

8.28 Construction. The parties have participated jointly in the negotiation and drafting of this Agreement. In the event an ambiguity or question of intent or interpretation arises with respect to this Agreement, this Agreement shall be construed as if drafted jointly by the parties and in accordance with its fair meaning. There shall be no presumption or burden of proof favoring or disfavoring any party by virtue of the authorship of any of the provisions of this Agreement.

8.29 Counterparts. This Agreement may be executed in one or more counterparts, each of which shall be deemed an original. All counterparts shall be construed together and shall constitute one agreement.

8.30 Funding Source Conditions – Contractor’s Obligation. Contractor acknowledges that the City may be paying for the Project by using funds it receives or will receive from various funding sources in the form of grants and/or subsidies, and the like under certain terms and conditions. Contractor acknowledges and agrees that any failure of the Contractor and/or its subcontractors to perform its obligations under the Contract, including, but not limited to, timely submitting accurate reports and records, that in any way results in the City not meeting the terms and conditions placed on the funds by the funding source, or forfeiting its entitlement to or, otherwise, not receiving, the funds, then the Contractor shall be liable to pay the City for the funds not granted to the City on the Project.

8.31 Entire Agreement. This Agreement constitutes the entire agreement between the parties with respect to any matter referenced herein and supersedes any and all other prior writings and oral negotiations. This Agreement may be modified only in writing, and signed by the parties in interest at the time of such modification. The terms of this Agreement shall prevail over any inconsistent provision in any other contract document appurtenant hereto, including exhibits to this Agreement.

City Project No. 1-R-23

IN WITNESS WHEREOF, the parties have executed and entered into this Agreement as of the date first written above.

CITY OF LA HABRA,
A municipal corporation

Jim Sadro, City Manager

Date: _____

CONTRACTOR

Signature

Date: _____

Name and Title

Social Security or Taxpayer ID Number

ATTEST:

Rhonda J. Barone, City Clerk

Date: _____

APPROVED AS TO FORM:

Keith F. Collins, City Attorney

Date: _____

(Use of City Bond Form is Required)

**LABOR AND MATERIAL PAYMENT BOND
PUBLIC WORK (CALIFORNIA)**

KNOW ALL MEN BY THESE PRESENT:

WHEREAS, _____, as Principal, has entered into a contract dated May 19th, 2025 with the City of La Habra (Obligee) referred to and made a part hereof to perform the following work, to wit: Macy Street Rehabilitation and all appurtenant work in accordance with PROJECT NO. 1-R-23, which requires Principal to file this bond to secure claims made in relation to the project.

NOW THEREFORE, we, _____, as Principal, and _____, a corporation organized under the laws of _____ and duly authorized to transact business in the State of California, as Surety, are held firmly bound unto the City of La Habra, as Obligee, and all sub-contractors, laborers, material persons and other persons employed in the performance of the referenced agreement, in the sum of _____ Dollars (\$ _____ .00), lawful money of the United States of America, for the payment whereof well and truly to be made the Principal and Surety bind themselves, their heirs, executors, administrators, successors, and assigns, jointly and severally, firmly by these presents.

If the above bounden PRINCIPAL, his or its heirs, executors, administrators, successors, assigns, or any of his or its sub-contractors, fails to pay for any materials, provisions, provender, or other supplies, or teams, implements or machinery, used in, upon, for or about the performance of the work contracted to be done, or for any work or labor to persons named in Section 9100 or the Civil Code, thereon of any kind, or for amounts due under the Unemployment Insurance Code with respect to such work or labor deducted, withheld and paid over to the Employment Development Department from the wages of employees of the contractor and sub-contractors pursuant to Section 13020 of the Unemployment Insurance Code, that the SURETY on this bond will pay the same, in an amount not exceeding the sum specified in this bond, AND ALSO, in case suit is brought upon this bond, a reasonable attorney's fee, which shall be awarded by the court to the prevailing party in said suit, said attorney's fee to be taxed as costs in said suit and to be included in the judgment herein rendered.

As part of the obligation secured hereby, the SURETY shall not be exonerated or released from the obligation of the bond by any change, alteration, or modification in or of any contract, plans, specifications, or agreement pertaining or relating to any scheme or work of improvement or pertaining or relating to the furnishing of labor, materials, or equipment therefor, nor by any change or modification of any terms of payment or extension of the time for any payment pertaining or relating to any scheme of work of improvement, nor by any rescission or attempted rescission of the contract, agreement or bond, nor by any conditions precedent or subsequent in the bond attempting to limit the right of recovery of claimants otherwise entitled to recover under

any such contract or agreement, or under the bond, nor, where the bond is given for the benefit of claimants, by any fraud practiced by any person other than the claimant seeking to recover on the bond.

This bond shall inure to the benefit of any and all persons, companies and corporations entitled to file claims under the Civil Code so as to give them a right of action in a suit on this bond.

This bond is executed for the purpose of complying with the laws of the State of California and shall inure to the benefit of any of the persons named in Section 9100 of the Civil Code of the State of California.

IN WITNESS THEREOF, we have hereunto set our hands and seals this _____ day of _____, 20__.

(Corporate Seal)

Principal

By _____

Title

(Corporate Seal)

Principal

By _____

Title

APPROVED AS TO FORM:
/s/ Keith F. Collins
City Attorney

FAITHFUL PERFORMANCE BOND

KNOW ALL MEN BY THESE PRESENTS:

That we, _____

_____ hereinafter referred to as

“Contractor”, as principal, and _____

_____ as surety, are held and firmly

bound unto City of La Habra in the sum of _____

_____ Lawful money of the United States of America for the payment of which sum well and truly to be made we bind ourselves jointly and severally, firmly by these presents.

The condition of the foregoing obligation is such that WHEREAS, said Contract has been awarded and is about to enter into the annexed contract with City of La Habra for construction of Street Improvements as specifically set forth in the documents entitled:

**MACY STREET REHABILITATION PROJECT
CITY PROJECT NO. 1-R-23**

and is required under the terms of the Contract to give this bond in connection with the execution of said contract.

NOW, THEREFORE, if the said Contractor shall well and truly do and perform all of the covenants and obligations of said contract on his part to be done and performed at the times and in the manner specified herein, then this obligation shall be null and void, otherwise it shall be and remain in full force and effect.

PROVIDED, that any alterations in the work to be done or the materials to be furnished which may be made pursuant to the terms of said Contract shall not in any way release either the Contractor or the surety thereunder nor shall any extensions of time granted under the provisions of said Contract release either the Contractor or the surety, and notice of such alterations or extensions of the Contract is hereby waived by the surety.

WITNESS our hands this _____ day of _____, 2025.

Contractor

BY: _____

(Seal)

Title

APPROVED:

Surety

BY: _____

(Seal)

Mailing Address of Surety:

Telephone Number of Surety

Page 1 of 1

(Use of City form is required)

SUPPLEMENTAL INFORMATION TO BE COMPLETED BY PRINCIPAL

If an individual, so state. If a firm or co-partnership, state the firm and give the names of all individual co-partners composing the partnership. If a Corporation, state legal name of corporation; state also the names of the president, secretary, treasurer and manager thereof.

Business Address: _____

Telephone Number: _____

Date: _____

Print Name: _____
Principal

Signature: _____
Title

(Use of City form
is required)

TAX IDENTIFICATION NUMBER

The Tax Equity and Fiscal Responsibility Act of 1982 requires the payer (City of La Habra) to report to the Internal Revenue Service taxable payments to payees.

You (as a payee) are required by law to provide us with your Taxpayer Identification Number (if an individual or partnership, your Social Security Number). If you do not provide us with your correct identification number, you may be subject to a penalty imposed by the Internal Revenue Service. The payments subject to withholdings may include, but are not limited to, interest, dividends, or other payments the City of La Habra made to you. Other payments may include rents, royalties, commissions and fees for service of non-employees.

If you are exempt from income tax, we are still required, by law, to maintain a Tax Identification Number on file. **PLEASE PROVIDE YOUR TAX IDENTIFICATION NUMBER next to the appropriate listing below, sign, date and return to:**

CITY OF LA HABRA FINANCE DEPARTMENT
110 E. La Habra Blvd
La Habra, CA 90631

Exempt: Yes___ No___ Telephone () _____

CORPORATION: _____

U.S.A. OR ANY AGENCIES THEREOF: _____

IRS CODE #501 TAX-EXEMPT ORGANIZATION: _____

A NON-COMMISSIONED CITY OF LA HABRA EMPLOYEE: _____

SOLE PROPRIETOR: _____

A PARTNERSHIP: _____

OTHER: _____(Explain)

Signature/Title: _____ Date: _____

BID GUARANTEE

**TO THE CITY OF LA HABRA
MACY STREET REHABILITATION PROJECT, CITY PROJECT NO. 1-R-23**

As a material inducement to the City to award the contract for Project No. _____ to _____, the undersigned (“Guarantor”) has agreed to enter into this guarantee. The Guarantor hereby unconditionally guarantees to the fullest extent allowed by law the following work included in this project: _____ (“the work”).

Guarantor guarantees that the materials and equipment used by itself and its subcontractors will be free from defects and that the work will conform to the plans and specifications. Should any of the materials or equipment prove defective or should the work as a whole, or any part thereof, prove defective for any reason whatsoever (except due to intentional torts by the City), or should the work as a whole or any part thereof fail to operate properly or fail to comply with the plans and specifications, Guarantor will, at the City’s sole election: 1) reimburse the City, upon written demand, for all of the City’s expenses incurred replacing or restoring any such equipment or materials, including the cost of any work necessary to make such replacement or repairs; or 2) replace any such defective material or equipment and repair said work completely, all without any cost to the City. Guarantor further guarantees that any such repair work will conform to the plans and specifications for the project. This guarantee will remain in effect for one year from the date on which the contracted for work is accepted for use by the City.

Guarantor understands and agrees that the City shall have the unqualified option to make any replacements or repairs itself or to have such replacement, repair, performed by the undersigned. The City shall have no obligation to consult with Guarantor before the City proceeds to perform any repair, replacement, or work itself. If the City elects to have Guarantor perform said repair, replacement, or work, Guarantor agrees that the repair, replacement, or work shall be performed within 15 days after receipt of a written demand from the City.

If the City elects to perform the replacement, repairs itself, Guarantor agrees to make reimbursement payment within 15 days after receipt of a written demand for payment from the City.

If the Guarantor fails or refuses to comply with this guarantee, the City shall be entitled to all costs and expenses, including attorneys and expert fees, reasonably incurred by reason of Guarantor’s failure or refusal.

Guarantor _____ Date: _____

Contractor: _____ By: _____

Title: _____

STATEMENT OF NON COLLUSION BY CONTRACTOR

The undersigned who submits herewith to the City of La Habra a bid or proposal does hereby certify:

- a. That all statements of fact in such bid or proposal are true;
- b. That such bid or proposal was not made in the interest of or on behalf of any undisclosed person, partnership, company, association, organization or corporation;
- c. That such bid or proposal is genuine and not collusive or sham;
- d. That said bidder has not, directly or indirectly by agreement, communication or conference with anyone, attempted to induce action prejudicial to the interest of the City of La Habra or of any other bidder or anyone else interested in the proposed procurement;
- e. Did not, directly or indirectly, collude, conspire, connive or agree with anyone else that said bidder or anyone else would submit a false or sham bid or proposal, or that anyone should refrain from bidding or withdraw his bid or proposal;
- f. Did not in any manner, directly or indirectly seek by agreement, communication or conference with anyone to raise or fix the bid or proposal price of said bidder or of anyone else, or to raise or fix any overhead, profit or cost element of his bid or proposal price, or that of anyone else;
- g. Did not, directly or indirectly, submit his bid or proposal price or any breakdown thereof, or the contents thereof, or divulge information or data relative thereto, to any corporation, partnership, company, association, organization, bid depository, or to any member agent thereof, or to any individual or group of individuals, except to the City of La Habra, or to any person or persons who have a partnership or their financial interest with said bidder in his business.
- h. Did not provide, directly or indirectly to any officer or employee of the City of La Habra any gratuity, entertainment, meals, or anything of value, whatsoever, which could be objectively construed as intending to invoke any form of reciprocation or favorable treatment.
- i. That no officer or principal of the undersigned firm is related to any officer or employee of the city by blood or marriage within the third degree or is employed, either full or part time, by the City of La Habra either currently or within the last two (2) years.
- j. That no officer or principal of the undersigned firm nor any subcontractor to be engaged by the principal has been convicted by a court of competent jurisdiction of any charge of fraud, bribery, collusion, conspiracy or any other act in violation of any state or federal antitrust law in connection with the bidding upon award of, or performance of, any public work contract, with any public entity, within the last three years.

I certify, under penalty of perjury under the laws of the State of California, that the foregoing is true and correct and that this certification was executed:

On _____ at _____ California.

Firm _____

(Signature)

Street _____

(Print Name & Title)

City _____ State _____ Zip _____

CERTIFICATION OF COMPLIANCE

AFFIRMATIVE ACTION REQUIREMENTS

EQUAL EMPLOYMENT OPPORTUNITY

For

**MACY STREET REHABILITATION PROJECT
CITY PROJECT NO. 1-R-23**

_____ Certifies that:
(Contractor)

It has adopted and approved affirmative action plan in compliance with Title VII of the Civil Rights Act and the Equal Employment Opportunity Act of 1972 and agrees to submit a copy of that plan to the Assistant to the City Manager/Personnel of the City of La Habra for inspection prior to the award of contract.

Signed: _____

By: _____

Title: _____

Date: _____

EXHIBIT A
SCOPE OF SERVICES

SECTION D
PROPOSAL

PROPOSAL

City of La Habra
Civic Center
110 E. La Habra Blvd.
La Habra, California 90631

Gentlemen:

The undersigned hereby proposes to perform all work for which a contract may be awarded him and to furnish any and all plant, labor, services, materials, tools, equipment, supplies, transportation, utilities, and all other items and facilities necessary therefor as provided in the Contract Documents, and to do everything required therein for the project specifically set forth in documents entitled:

**MACY STREET REHABILITATION PROJECT
CITY PROJECT NO. 1-R-23**

together with appurtenances thereto, all as set forth on the drawing and in the specifications and other Contract Documents; and, he further proposes and agrees that if this Proposal is accepted he will contract in the form and manner stipulated to perform all the work called for by drawings, specifications and other Contract Documents and to complete all such work in strict conformity therewith within the time limits set forth therein, and that he will accept as full payment therefor the prices set forth in the Bid Schedule forming a part hereof.

A *(Cashier's Check) *(Certified Check) *(Bid Bond) properly made payable to City of La Habra hereinafter designated as the Owner for the sum of Thirty nine thousand one hundred thirty one dollars (\$ 39,131.00), which amount is not less than ten percent (10%) of the total amount of this bid, is attached hereto and is given as a guarantee that the undersigned will execute the Agreement and furnish the required bonds if awarded the Contract; and, in case of failure to do so within the time provided the proceeds of said check shall be forfeited to the *Owner/Sureties Liability to the Owner for forfeiture of the face amount of the Bond shall be considered as established.

(*) Delete inapplicable word or phrase.

It is understood and agreed that:

1. The undersigned has carefully examined all the Contract Documents which will form a part of the Contract;
2. The undersigned has, by investigation of the site of the work and otherwise, satisfied himself as to the nature and location of the work and has fully informed himself as to all conditions and matters which can in any way affect the work or the cost thereof;
3. The undersigned fully understands the scope of the work and has checked carefully all words and figures inserted in this proposal and he further understands that the Owner will in no way be responsible for any errors or omissions in the preparation of this proposal;
4. The undersigned will execute the Agreement and furnish the required Performance and Payment Bonds and proof of insurance coverage, within ten (10) days (not

including Saturdays, Sundays and holidays) after notice to him of acceptance of his bid by the Owner; and further, that this bid may not be withdrawn for a period of sixty (60) days after the date set for the opening thereof, unless otherwise required by law. If any bidder shall withdraw his bid within said period, the Contractor shall be liable under the provisions of the Bid Security or the Contract and his surety shall be liable under the Bid Bond, as the case may be;

5. The undersigned hereby certifies that this proposal is genuine and not sham or collusive or made in the interest or in behalf of any person not herein named and the undersigned has not directly or indirectly induced or solicited any other bidder to put in a sham bid or any other person, firm or corporation to refrain from bidding; the undersigned has not in any manner sought by collusion to secure for himself an advantage over any other bidder;
6. In conformance with current statutory requirements of Section 1860, et seq., of the Labor Code of the State of California, the undersigned confirms the following as his certification:

I am aware of the provisions of Section 3700 of the Labor Code which requires every employer to be insured against liability of worker's compensation or to undertake in accordance with the provisions before commencing the performance of the work of this contract.

NOW, in compliance with the Notice Inviting Bids and all the provisions hereinbefore stipulated, the undersigned, with full cognizance thereof, hereby proposes to perform the entire work for the prices set forth in the attached Bid Schedule upon which award of the Contract is made.

Date: April 15, 2025

Bidder Copp Contracting, Inc.

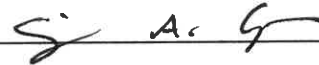
By 

Title Ezekiel A. Copp, President

Bidder's Post Office Address:

6751 Stanton Avenue

Buena Park, CA 90621

Corporation organized under
the laws of the State of California

Names and addresses of all owners
of the firm or names and titles of
all officers of the corporation:

Ezekiel A. Copp, President

Dennis W. Copp, Vice President

Erlinda Copp, Secretary

(corporate seal)

BIDDER'S INFORMATION

Contractor's License No. 384209 Expiration Date 11/30/2025

Classification of Contractor's License No. A

Contractor Copp Contracting, Inc.
(name of firm)

By  Ezekiel A. Copp, President
(signature) (title)

Business Address: 6751 Stanton Avenue
Buena Park, CA 90621

Phone (714) 522-7754

I/We certify that the information provided above is complete and true to the best of my/our knowledge.

Copp Contracting, Inc. April 15, 2025
Contractor Date

Contractor's DIR Public Works Registration No. 1000004241

EXHIBIT A
BID SCHEDULE

MACY STREET REHABILITATION PROJECT
CITY PROJECT NO. 1-R-23

ITEM	DESCRIPTION	QUANTITY	UNIT	UNIT PRICE	AMOUNT
1	MOBILIZATION, DEMOBILIZATION, & CLEANUP (Not to Exceed Five Percent (5%) of the total bid amount)	1	LS	\$12,000.00	\$12,000.00
2	TRAFFIC CONTROL AND PUBLIC NOTIFICATION (Not to Exceed Five Percent (5%) of the total bid amount)	1	LS	\$10,607.00	\$10,607.00
3	CONSTRUCTION SURVEYING AND MONUMENT PRESERVATION.	1	LS	\$6,000.00	\$6,000.00
4	STORM WATER BEST MANAGEMENT PRACTICES (BMPs)	1	LS	\$3,000.00	\$3,000.00
5	COLD MILL EXISTING AC PAVEMENT TO 2" DEPTH	99,500	SF	\$0.39	\$38,805.00
6	UNCLASSIFIED EXCAVATION AND DISPOSAL. LOCAL DIGOUTS. REMOVE EXISTING 12" DEPTH, SCARIFY, COMPACT BASE AND REGRADE.	70	CY	\$125.00	\$8,750.00
7	CONSTRUCT HEADER BOARD WITH STAKES	155	LF	\$9.00	\$1,395.00
8	PLACE 6" CMB FINE GRADE, SCARIFY AND COMPACT BASE.	70	TON	\$125.00	\$8,750.00
9	INSTALL 4" THICK ASPHALT CONCRETE BASE COURSE (B PG 64-10)	50	TON	\$210.00	\$10,500.00
10	INSTALL 2" THICK ASPHALT RUBBER HOT MIX (ARHM-GG-C PG 64-16) OVERLAY.	1,300	TON	\$127.81	\$166,153.00
11	INSTALL PCC CURB AND GUTTER PER SPPWC 120-3 A2-8	250	LF	\$105.00	\$26,250.00

12	REMOVE EXISTING & CONSTRUCT NEW ADA COMPLIANT CURB RAMP PER PLANS.	1	EA	\$9,800.00	\$9,800.00
13	SAWCUT AND REMOVE EXISTING DRIVEWAY APPROACH. CONSTRUCT NEW PCC DRIVEWAY APPROACH PER SPPWC 110-2 TYPE B.	90	SF	\$30.50	\$2,745.00
14	SAWCUT AND REMOVE EXISTING SIDEWALK. CONSTRUCT NEW 4" THICK PCC SIDEWALK OVER 4" CMB AS NEEDED.	360	SF	\$31.00	\$11,160.00
15	FURNISH AND INSTALL TRAFFIC SIGNING, THERMOPLASTIC PAVEMENT MARKINGS AND STRIPING.	1	LS	\$21,400.00	\$21,400.00
16	INSTALL 6-FOOT DIAMETER TYPE E TRAFFIC LOOP	1	EA	\$925.00	\$925.00
17	INSTALL 6-FOOT DIAMETER TYPE F TRAFFIC LOOP	2	EA	\$1,000.00	\$2,000.00
18	ADJUST MANHOLE FRAME AND COVER TO GRADE	7	EA	\$2,030.00	\$14,210.00
19	REMOVE AND REPLACE AC CURB PER SPPWC 120-3 D1-8	235	LF	\$47.00	\$11,045.00
20	WHITTIER UNCLASSIFIED EXCAVATION AND DISPOSAL. LOCAL DIGOUTS. REMOVE EXISTING TO 12" & 6"- 4" DEPTHS, SCARIFY, COMPACT BASE AND REGRADE	52	CY	\$125.00	\$6,500.00

21	WHITTIER PLACE 6" CMB FINE GRADE, SCARIFY AND COMPACT BASE.	30	TON	\$125.00	\$ 3,750.00
22	WHITTIER INSTALL 4" THICK ASPHALT CONCRETE BASE COURSE (B PG 64-10)	51	TON	\$210.00	\$ 10,710.00
23	WHITTIER INSTALL 2" THICK ASPHALT RUBBER HOT MIX (ARHM-GG-C PG 64-16) OVERLAY.	38	TON	\$ 127.81	\$ 4,856.78

TOTAL BID PRICE FOR BID SCHEDULE IN FIGURES: \$ 391,311.78

TOTAL BID PRICE FOR BID SCHEDULE IN WORDS: Three hundred

ninety-one thousand three hundred eleven dollars
and seventy-eight cents.

Note: All bid quantities are estimated and for bidding purposes only, it may be increased or decreased at the discretion of the CITY. The provisions of Sections 3-2.2.2 and 3-2.2.3 of the Greenbook governing increases or decreases in quantity of more than 25% shall not apply.

Note: The TOTAL BID PRICE shall be used as the basis of bid in determining the low bid for this project.

Copp Contracting, Inc.
CONTRACTOR

BY *S. A. Copp*

Ezekiel A. Copp, President
TITLE

April 15, 2025
DATE

ACKNOWLEDGEMENT OF ADDENDA RECEIVED

The Bidder shall acknowledge the receipt of addenda by placing an "X" by each addendum received.

- Addendum No. 1 N/A
- Addendum No. 2 _____
- Addendum No. 3 _____
- Addendum No. 4 _____
- Addendum No. 5 _____
- Addendum No. 6 _____
- Addendum No. 7 _____
- Addendum No. 8 _____

If an addendum or addenda have been issued by the CITY and is not noted above as being received by the Bidder, the Bid Proposal may be rejected.

REFERENCES

[Work similar in scope magnitude and degree of difficulty completed by Contractor within the past three (3) years.]

1. Name (Firm/Agency): City of Westminster
Address: 8200 Westminster Blvd., Westminster CA 92683

Contact Person: Cindy Huynh Telephone No. (714)-548-3497
Title of Project: CDBG 24-25 Street Improvements Project
Project Location: Various streets throughout the city.
Date of Completion: April 2025 Contract Amount: \$ 546,646.00
2. Name (Firm/Agency): City of Menifee
Address: 29844 Haun Road, Menifee CA 92586

Contact Person: Don Sharp Telephone No. (951)-672-6777
Title of Project: Menifee Road Resurfacing Project, CIP 24-21
Project Location: Menifee Road from McCall Blvd. to Aldergate Dr.
Date of Completion: November 2024 Contract Amount: \$ 1,430,470.92
3. Name (Firm/Agency): City of Westminster
Address: 8200 Westminster Blvd., Westminster CA 92683

Contact Person: Theresa Tran Telephone No. (714)-548-3464
Title of Project: Street Improvement Project for Citywide Residential Streets, Project No. CDBG 23-24
Project Location: Various streets throughout the city.
Date of Completion: June 2024 Contract Amount: \$ 914,344.64
4. Name (Firm/Agency): City of Artesia
Address: 18747 Clarkdale Ave., Artesia CA 90701

Contact Person: Ernesto Sanchez Telephone No. (562)-865-6262
Title of Project: FY 23-24 Street Improvement Project, Project No. 2023-003
Project Location: Various streets throughout the city.
Date of Completion: May 2024 Contract Amount: \$ 2,016,970.76

AGENCY	WORK DESCRIPTION	CONTRACT AMOUNT	COMPLETED	FEDERAL LAWS
LARCH AVE. CITY OF LAWDALE 4722 MANHATTAN BEACH BLVD. LAWDALE, CA 90260 FRANK SENTENO 310-973-3266	COLDMILL, R&R A/C, CONSTRUCT	294,771	2/2017	Yes
CALIMESA PAVEMENT CITY OF CALIMESA P O BOX 1190 CALIMESA, CA 92320 STEVE LEDBETTER 909-725-8549	COLDMILL, PCC, A/C OVERLAY, SLURRY, LOOPS, STRIPING	230,710.40	2/2017	NO
MINES CITY OF MONTEBELLO 1600 W BEVERLY BLVD. MONTEBELLO, CA 90640 HORMOZ VAHID 323-887-1200	PCC, COLDMILL, ARHM OVERLAY, M/H, LOOPS, SLURRY	236,899.70	3/2017	NO
PAVEMENT PRESERVATION - CHIPSEAL CITY OF SAN DIMAS 245 E BONITA AVE SAN DIMAS, CA 91773 JOHN CAMPBELL 909-394-6270	CHIPSEAL, SLURRY, CRACKSEAL	370,354	6/2017	NO
TENEJA ROAD REPAIR TENEJA COMMUNITY CITY OF TENEJA 24837 JEFFERSON #207 MURRIETA, CA 92562 ARLENE MILLER 951-696-5999	CRACKSEAL, A/C PAVE, CHIPSEAL, STRIPING	176,268	6/2017	NO
CDBG WEST BAY STREET CITY OF COSTA MESA 77 FAIR DRIVE COSTA MESA, CA 92628 MEJIA BALTAZAR 714-754-5291	COLDMILL, A/C OVERLAY, M/H, LOOPS, STRIPING, SLURRY	192,969	10/2017	YES
AREA 5 CITY OF DIAMOND BAR 21825 E. Copley Drive Diamond Bar, CA 90765-4177 Kimberly Young 909-839-7044	COLDMILL, AC OVERLAY, PCC CAPESEAL	1,731,183	10/2017	NO
2016-17 & 2017-18 ANNUAL PAVEMENT REHAB CITY OF BUENA PARK 6650 BEACH BLVD. BUENA PARK, CA 90620 JEFF TOWNSEND 714-562-3754	COLDMILL, A/C OVERLAY, PCC MANHOLE, STRIPING	608,409	11/2017	NO
JASPERSON WAY CALIFORNIA NEVADA CITY OF WESTMINSTER 8200 WESTMINSTER BLVD. WESTMINSTER, CA 92683 THERESA TRAN 714-548-3464	SLURRY, MANHOLES, COLD MILL A/C, FABRIC, PCC, STRIPING	291,184	2/2018	NO
CLARADAY STREET & GREER AVE CITY OF GLENDORA 116 E. FOOTHILL BLVD. GLENDORA, CA 91741 BARDIA RASTAN 626-914-8258	MANHOLE, SLURRY, COLD MILL A/C PCC	232,461	3/2018	NO
KENSINGTON NEIGHBORHOOD CITY OF LAGUNA NIGUEL	PCC, A/C PAVE, COLD MILL, STRIPING	954,163	6/2018	YES

30111 CROWN VALLEY PKWY
LAGUNA NIGUEL, CA 92677
FRANK BORGES 949-362-4337

POMONA AVE STREET IMPROVEMENT CITY OF COSTA MESA 77 FAIR DRIVE COSTA MESA, CA 92628 MEJIA BALTAZAR 714-754-5291	PCC, A/C PAVE, MANHOLES, STRIPING	878,896	8/2018	YES
CITYWIDE SLURRY SEAL FY 17-18 CITY OF WESTMINSTER 8200 WESTMINSTER BLVD. WESTMINSTER, CA 92683 THERESA TRAN 714-548-3464	R&R A/C, PCC, STRIPING, SLURRY SEAL	757,957	8/2018	NO
FAIRWAY BLVD PAVEMENT REHABILITATION CITY OF CHINO HILLS 14000 CITY CENTER DR CHINO HILLS, CA 91706 CARL HASSELL 909-364-2817	COLD MILL, ASPHALT OVERLAY, STRIPING	132,169	2/2019	NO
FROST AVE STREET IMPROVEMENTS CITY OF CHINO HILLS 14000 CITY CENTER DR CHINO HILLS, CA 90706 CARL HASSELL 909-364-2817	COLD MILL, ASPHALT OVERLAY STRIPING, MANHOLES	120,047	3/2019	NO
MIRALAGO RESURFACING CITY OF MENIFEE 29844 HAUN RD MENIFEE, CA 92586 CARLOS GERONIMO (951) 672-6777	COLD MILL, CHIP SEAL, ASPHALT OVERLAY, SLURRY	671,331	4/2019	YES
CITYWIDE SLURRY SEAL FY 18-19 CITY OF WESTMINSTER 8200 WESTMINSTER BLVD. WESTMINSTER, CA 92683 THERESA TRAN 714-548-3464	R&R ASPHALT, SLURRY	763,870	7/2019	YES
AREA 7 & DIAMOND BAR BLVD CITY OF DIAMOND BAR 21825 COPLEY DRIVE DIAMOND BAR, CA 90765 FABIAN AOUN 909- 839-7038	CONCRETE, COLD MILL, AC OVERLAY CHIP SEAL, SLURRY SEAL	2,414,825	2/2020	NO
FETILE STREET IMPROVEMENTS CITY OF LYNWOOD 11330 BULLIS RD LYNWOOD, CA 90262 THOMAS THORTON 310-603-0220	COLD MILL, AC PAVE, CONCRETE, STRIPING	191,259	3/2020	NO
VIRGINIA AVE STREET AND WATER MAIN IMPROVEMENTS CITY OF LYNWOOD 11330 BULLIS RD LYNWOOD, CA 90262 THOMAS THORTON 310-603-0220	COLD MILL, AC PAVE CONCRETE, WATER LINE, STRIPING	671,818	6/2020	NO
WOODVIEW ROAD IMPROVEMENTS CITY IF CHINO HILLS 14000 CITY CENTER DR CHINO HILLS, CA 91706 CARL HASSEL 909-364-2817	COLD MILL, AC OVERLAY, STRIPING	115,780	5/2020	NO
BARSTOW-CHIP SEAL CO. OF SAN BERNARDINO SERVICE AREA 70/R42 222 W. HOSPITALITY LN., 2ND FLOOR	CHIP SEAL, FOG SEAL	133,072	5/2020	NO

SAN BERNARDINO, CA 92415 PHIL KRAUSE 909-386-8800					
CANON LANE STREET IMPROVEMENTS CITY OF CHINO HILLS 14000 CITY CENTER DR CHINO HILLS, CA 91706 CARL HASSEL 909-364-2817	COLD MILL, AC OVERLAY, CRACK SEAL SLURRY SEAL	82,872	9/2020	NO	
CDBG FUNDED 19-20 VARIOUS STREETS CITY OF GLENDORA 116 E FOOTHILL BLVD GLENDORA, CA 91741 MALIHA ANSARI 626-914-8594	COLD MILL, ARHM OVERLAY, PCC	282,484	8/2020	YES	
PIPELINE AVENUE-M/H SEWER ACCESS ROAD CITY OF CHINO HILLS 14000 CITY CENTER DR CHINO HILLS, CA 90706 CARL HASSEL 909-364-2817	GRADING, A/C PAVE	110,121	10/2020	NO	
SOUTH STREET IMPROVEMENTS CITY OF CERRITOS 18125 BLOOMFIELD AVENUE CERRITOS, CA 90703 ALBERT ARTEAGA 562-860-0311	COLD MILL, AC REPAIRS, STRIPING SLURRY SEAL	218,560	11/2020	NO	
2019 SLURRY SEAL PROJECT CITY OF LAKE FOREST 25550 COMMERCENTRE DR STE. 100 LAKE FOREST, CA 92630 TAYLOR ABERNATHY 949-461-3490	A/C PAVE, SLURRY SEAL, STRIPING	1,211,042	12/2020	NO	
LUCRETIA AVE. PAVEMENT REHABILITATION CITY OF JURUPA VALLEY 8930 LIMONITE AVENUE JURUPA VALLEY, CA 92509 CHASE KEYS 951-332-6464	COLD MILL, AC OVERLAY, PCC STRIPING, M/H	420,611	4/2021	NO	
FY 18-19/19-20/20-21 PAVEMENT IMPROVEMENTS CITY OF HIGHLAND 27215 BASE LINE HIGHLAND, CA 92346 CARLOS ZAMANO 909-864-6861	COLD MILL, ARHM, PCC, CRACK REPAIR SLURRY SEAL, STRIPING, M/H	664,257	5/2021	YES	
2020-2021 PAVEMENT IMPROVEMENTS, ST 82101 CITY OF SIERRA MADRE 232 WEST SIERRA MADRE BLVD SIERRA MADRE, CA 91024 CHRIS CIMINO 626-355-7135	CONCRETE, COLD MILL, AC OVERLAY CHIP SEAL, SLURRY SEAL, TREES, STRIPING, M/H	1,021,571	9/2021	NO	
FOUNDERS DRIVE PAVEMENT REHAB, ST 21002 CITY OF CHINO HILLS 14000 CITY CENTER DR CHINO HILLS, CA 90706 CARL HASSEL 909-364-2817	GRIND AC, AC OVERLAY, CONCRETE STRIPING, M/H	278,017	9/2021	NO	
Glen Ridge Pavement Rehabilitation ST 21003 CITY OF CHINO HILLS 14000 CITY CENTER DR CHINO HILLS, CA 90706 CARL HASSEL 909-364-2817	CONCRETE, COLD MILL, A/C OVERLAY R&R AC, STRIPING, M/H	241,752	9/2021	NO	
RANCHOLAVITA RESURFACING PROJECT, CIP 21-16 CITY OF MENIFEE 29844 HAUN RD MENIFEE, CA 92586	CONCRETE, COLD MILLS, AC OVERLAY STRIPING, M/H	771,270	12/2021	NO	

DIEGO GUILLEN 951-672-6777

CITYWIDE OVERLAY STREET IMPROVEMENTS, PROJECT NO 21-22

CITY OF WESTMINSTER8200 WESTMINSTER BLVD.
WESTMINSTER, CA 92683
THERESA TRAN 714-548-3464CONCRETE, COLD MILL, ARHM OVERLAY
LOOPS, STRIPING, M/H

917,429

2/1/2022

NO

FORTUNA ET. AL. STREET IMPROVEMENTS PROJECT

CITY OF NORCO2870 CLARK AVENUE
NORCO, CA 92860
SAM NELSON 951-270-5677

AC OVERLAY, COLD MILL

191,607

2/28/2022

NO

PEACOCK PL COMMUNITY RESURFACING PROJECT

CITY OF MENIFEE29844 HAUN ROAD
MENIFEE, CA 92586
DON SHARP 951-672-6777

AC OVERLAY, REPAIR

938,650.00

7/1/2022

NO

RES. & COLLECTOR AREA 1 (GOLDEN SPRINGS)

CITY OF DIAMOND BAR21810 COPLEY DR.
DIAMOND BAR, CA 91765
CHRISTIAN MALPICA 909-839-7042CONCRETE, COLD MILL, AC REPAIRS,
AC OVERLAY, CAPE SEAL, STRIPING, M/H

2,635,516

10/3/2022

NO

STREETS IMPROVEMENT, CDBG 21-22

CITY OF WESTMINSTER8200 WESTMINSTER BLVD.
WESTMINSTER, CA 92683
THERESA TRAN 714-548-3464AC OVERLAY, CONCRETE, CRACK SEAL
SLURRY, STRIPING

407,113.02

11/1/2022

NO

CITYWIDE PAVEMENT REHABILITATION

CITY OF SAN BERNARDINO290 NORTH D STREET
SAN BERNARDINO, CA 92401
MIRELA GRIGORESCU 909-384-5202CONCRETE, A/C REPAIRS, CHIP SEAL,
SLURRY SEAL, LOOPS

1,563,483

5/31/2023

NO

CITYWIDE OVERLAY STREET IMPROVEMENTS PROJECT No 22-23

CITY OF WESTMINSTER8200 WESTMINSTER BLVD.
WESTMINSTER, CA 92683
THERESA TRAN 714-548-3464

CONCRETE, COLD MILL, ARHM OVERLAY

1,241,458

5/31/2023

YES

RESIDENTIAL & COLLECTOR STREETS REHABILITATION (AREA 2)
AND ARTERIAL STREETS REHABILITATION (GOLDEN SPRINGS)**CITY OF DIAMOND BAR**21810 COPLEY DR.
DIAMOND BAR, CA 91765
CHRISTIAN MALPICA 909-839-7042CONCRETE, COLD MILL, AC OVERLAY
CHIP SEAL, SLURRY SEAL

3,186,620.05

10/2023

NO

TOWNWIDE SLURRY/CAPE SEAL PROJECT

TOWN OF YUCCA VALLEY59828 BUSINESS CENTER DRIVE
YUCCA VALLEY, CA 92284
ALEX QISHTA 760-369-0801 x307

CAPE SEAL

1,365,728.12

10/2023

NO

CASA BLANCA NEIGHBORHOOD RESURFACING & WILLOWS/ LAKE RIDGE

CITY OF MENIFEE29844 HAUN ROAD
MENIFEE, CA 92586
DON SHARP 951-672-6777CONCRETE, ARAM, A/C REPAIRS, ARHM OVERLA
M/H, STRIPING

2,299,550.31

1/2024

NO

FISCAL YEAR 23-24 STREET IMPROVEMENT PROJECT, PROJECT No. 2023-003

CITY OF ARTESIA18747 CLARKDALE AVE
ARTESIA, CA 90701CONCRETE, COLD MILL, AC REPAIRS, AC OVERLAY
CHIP SEAL, SLURRY SEAL, M/H, STRIPING, LOOPS

2,061,970.76

5/2024

NO

ERNESTO SANCHEZ 562-865-6262

STREET IMPROVEMENT PROJECT FOR CITYWIDE RESIDENTIAL STREETS, PROJECT No. CDBG 23-24

CITY OF WESTMINSTER

8200 WESTMINSTER BLVD.

WESTMINSTER, CA 92683

THERESA TRAN 714-548-3464

CONCRETE, COLD MILL, ARHM OVERLAY
MH, STRIPING

914,344.64

6/2024

YES

LOCAL ROADS AC RESURFACING PROJECT

CITY OF MENIFEE

29844 HAUN ROAD

MENIFEE, CA 92586

DON SHARP 951-672-6777

CONCRETE, ARAM, ARHM OVERLAY
MH, STRIPING

727,909

8/2024

NO

SLURRY SEAL PROJECT; PMP No. 24-01

CITY OF MENIFEE

29844 HAUN ROAD

MENIFEE, CA 92586

DON SHARP 951-672-6777

CONCRETE, CAPE SEAL, MH, STRIPING

735,073

9/2024

NO

MENIFEE RD RESURFACING, CIP 24-21

CITY OF MENIFEE

29844 HAUN ROAD

MENIFEE, CA 92586

DON SHARP 951-672-6777

COLD MILL, AC OVERLAY, ARAM, CONCRETE
SLURRY SEAL, TRAFFIC LOOPS, UTILITY ADJ.
STRIPING

TBD

11/2024

NO

BELLA VERDE DR. PAVEMENT REHAB PROJECT

CITY OF MONTEBELLO

1600 W. BEVERLY BLVD

MONTEBELLO, CA 90640

MARIA ESTRADA (323) 271-4602

COLD MILL, AC OVERLAY, UTILITY ADJ, STRIPING
CONCRETE, FOG SEAL

1,010,978.55

12/2024

NO

SCENIC RIDGE DR & RIMROCK AVE PAVEMENT
REHAB. PROJECT**CITY OF CHINO HILLS**

14000 CITY CENTER DR.

CHINO HILLS, CA 91709

CARL HASSEL (909) 364-2817

COLD MILL, AC OVERLAY, UTILITY ADJ, STRIPING
CONCRETE

TBD

3/2025

NO

CDBG 24-25 STREET IMPROVEMENTS PROJECT

CITY OF WESTMINSTER

8200 WESTMINSTER BLVD.

WESTMINSTER, CA 92683

CINDY HUYNH (714) 548-3797

COLD MILL, ARHM OVERLAY, AC REPAIRS
CONCRETE, UT. ADJ, STRIPING

TBD

CURRENT

YES

DBE BIDDER'S LIST

All bidders/proposers are requested to provide the following information for all DBE and non-DBE contractors or consultants who provided a proposal, bid, quote, or were contacted by the proposed prime. This information is also requested from the proposed prime contractor/consultant and should be submitted with their bid/proposal. The City of La Habra will use this information to maintain and update a "Bidders" List to assist in the overall annual DBE goal-setting process.

Firm Name: <u>Copp Contracting, Inc.</u>	Phone: <u>(714)-522-7754</u>
Address: <u>6751 Stanton Avenue, Buena Park, CA 90621</u>	Fax: <u>(714)-522-2074</u>
Contact Person: <u>Hailey Copp</u>	No. of years in business: <u>45</u>
Is the firm currently certified as a DBE under 49 CFR Part 26: YES: <input type="checkbox"/> NO: <input checked="" type="checkbox"/>	
Type of work/services/materials provided by firm? _____	
<u>Paving, grading, chip sealing, concrete and asphalt removals.</u>	
<hr/> <hr/> What was your firm's Gross Annual receipts for last year?	
Less than \$1 Million	
Less than \$5 Million	
Less than \$10 Million	
Less than \$15 Million	
More than \$15 Million	

This form can be duplicated if necessary to report all bidders (DBEs and non-DBEs) information.

DBE BIDDER'S LIST

All bidders/proposers are requested to provide the following information for all DBE and non-DBE contractors or consultants who provided a proposal, bid, quote, or were contacted by the proposed prime. This information is also requested from the proposed prime contractor/consultant and should be submitted with their bid/proposal. The City of La Habra will use this information to maintain and update a "Bidders" List to assist in the overall annual DBE goal-setting process.

Firm Name: <u>On Point Land Surveying, Inc.</u>	Phone: <u>(909) 792.2221</u>
Address: <u>1906 Orange Tree Ln 240, Redlands, CA 92374</u>	Fax: <u>(909) 784.1836</u>
Contact Person: <u>Shari Todd</u>	No. of years in business: <u>20</u>
Is the firm currently certified as a DBE under 49 CFR Part 26: YES: <input type="checkbox"/> NO: <input checked="" type="checkbox"/>	
Type of work/services/materials provided by firm? <u>Land Surveying</u>	
What was your firm's Gross Annual receipts for last year? Less than \$1 Million <input checked="" type="checkbox"/> Less than \$5 Million <input checked="" type="checkbox"/> Less than \$10 Million Less than \$15 Million More than \$15 Million	

This form can be duplicated if necessary to report all bidders (DBEs and non-DBEs) information.

DBE BIDDER'S LIST

All bidders/proposers are requested to provide the following information for all DBE and non-DBE contractors or consultants who provided a proposal, bid, quote, or were contacted by the proposed prime. This information is also requested from the proposed prime contractor/consultant and should be submitted with their bid/proposal. The City of La Habra will use this information to maintain and update a "Bidders" List to assist in the overall annual DBE goal-setting process.

Firm Name:	<u>Interstate Striping</u>	Phone:	<u>909-774-9803</u>
Address:	<u>9784 Poplar Ave, Fontana, CA 92335</u>	Fax:	<u>None</u>
Contact Person:	<u>Stephanie Acosta</u>	No. of years in business:	<u>3</u>
Is the firm currently certified as a DBE under 49 CFR Part 26: YES: <input type="checkbox"/> NO: <input checked="" type="checkbox"/>			
Type of work/services/materials provided by firm? <u>Striping, Markings, Markers, Signage & Striping Removals.</u>			
What was your firm's Gross Annual receipts for last year?			
Less than \$1 Million			
Less than \$5 Million			
<u>Less than \$10 Million</u>			
Less than \$15 Million			
More than \$15 Million			

This form can be duplicated if necessary to report all bidders (DBEs and non-DBEs) information.

DBE BIDDER'S LIST

All bidders/proposers are requested to provide the following information for all DBE and non-DBE contractors or consultants who provided a proposal, bid, quote, or were contacted by the proposed prime. This information is also requested from the proposed prime contractor/consultant and should be submitted with their bid/proposal. The City of La Habra will use this information to maintain and update a "Bidders" List to assist in the overall annual DBE goal-setting process.

Firm Name: <u>All American Asphalt</u>	Phone: <u>951-736-7600</u>
Address: <u>400 East Sixth Street Corona, CA 92879</u>	
Fax: <u>951-736-7646</u>	
Contact Person: <u>Edward J Carlson, Vice President</u>	No. of years in business: <u>54</u>
Is the firm currently certified as a DBE under 49 CFR Part 26: YES: <input type="checkbox"/> NO: <input checked="" type="checkbox"/>	
Type of work/services/materials provided by firm? _____	
<u>Paving, Grading, Concrete, Grinding, Utility Adjustment, Slurry Seal</u>	
<u>Paving Fabric</u>	
<hr/> What was your firm's Gross Annual receipts for last year?	
Less than \$1 Million	
Less than \$5 Million	
Less than \$10 Million	
Less than \$15 Million	
More than \$15 Million	

This form can be duplicated if necessary to report all bidders (DBEs and non-DBEs) information.

DBE BIDDER'S LIST

All bidders/proposers are requested to provide the following information for all DBE and non-DBE contractors or consultants who provided a proposal, bid, quote, or were contacted by the proposed prime. This information is also requested from the proposed prime contractor/consultant and should be submitted with their bid/proposal. The City of La Habra will use this information to maintain and update a "Bidders" List to assist in the overall annual DBE goal-setting process.

Firm Name: Martinez Condeche, Inc. Phone: (626) 534-2979
Address: 920 West Verdugo Blvd Azusa, CA 91702 Fax: (626) 334-3365
Contact Person: Jose Mendoza No. of years in business: 45
Is the firm currently certified as a DBE under 49 CFR Part 26: YES: NO:
Type of work/services/materials provided by firm? Condeche

What was your firm's Gross Annual receipts for last year?

Less than \$1 Million
Less than \$5 Million
Less than \$10 Million
Less than \$15 Million
More than \$15 Million

This form can be duplicated if necessary to report all bidders (DBEs and non-DBEs) information.

DBE BIDDER'S LIST

All bidders/proposers are requested to provide the following information for all DBE and non-DBE contractors or consultants who provided a proposal, bid, quote, or were contacted by the proposed prime. This information is also requested from the proposed prime contractor/consultant and should be submitted with their bid/proposal. The City of La Habra will use this information to maintain and update a "Bidders" List to assist in the overall annual DBE goal-setting process.

Firm Name: <u>Global Road Sealing, Inc.</u>	Phone: <u>714-893-0845</u>
Address: <u>10641 Sycamore Ave., Stanton, CA 90680</u>	Fax: <u>714-893-0945</u>
Contact Person: <u>Tri La</u>	No. of years in business: <u>25</u>
Is the firm currently certified as a DBE under 49 CFR Part 26: YES: <input checked="" type="checkbox"/> NO: <input type="checkbox"/>	
Type of work/services/materials provided by firm? <u>Crack Sealing, Joint Sealing,</u> <u>Electrical</u>	
<hr/> What was your firm's Gross Annual receipts for last year?	
Less than \$1 Million	
Less than \$5 Million	
Less than \$10 Million	
Less than \$15 Million	
More than \$15 Million	

This form can be duplicated if necessary to report all bidders (DBEs and non-DBEs) information.

VIOLATIONS OF FEDERAL, STATE, OR LOCAL LAWS

1. Has your firm or its officers been assessed any penalties by an agency for noncompliance or violations of Federal, State, or Local labor laws and/or business or licensing regulations within the past five (5) years relating to your construction projects?

Yes/No: No Federal/State: N/A

If "yes", identify and describe, (including agency and status):

N/A

Have the penalties been paid? Yes/No: N/A

2. Does your firm or its officers have any ongoing investigations by any public agency regarding violations of the State Labor Code, California Business and Professions Code or State Licensing Laws?

Yes/No: No Code/Laws: N/A Section/Article: N/A

If "yes", identify and describe, (including agency and status):

N/A

DISQUALIFICATION OR DEBARMENT

Has your firm, any officer of your firm, or any employee who has a proprietary interest in your firm ever been disqualified, removed, or otherwise prevented from bidding on, performing work on, or completing a federal, state, or local project because of a violation of law or a safety regulation?

Yes/No: No

If yes, provide the following information (if more than once, use separate sheets):

Date: N/A Entity: N/A

Location: N/A

Reason: N/A

Provide Status and any Supplemental Statement: N/A

Has your firm been reinstated by this entity?

Yes/No: No

LIST OF SUBCONTRACTORS

**MACY STREET REHABILITATION PROJECT
CITY PROJECT NO. 1-R2-3**

The bidder shall list below the name and the location of the place of business of each Subcontractor who will perform work or render services to the prime contractor in or about the construction of the work or improvement in excess of one-half of one percent (1/2%) of the prime contractor's total bid or ten thousand dollars (\$10,000.00) whichever is greater in accordance with the requirements of Section 4100 to 4133 inclusive of the public contracts code.

<u>Work to be Performed</u>	<u>License Number</u>	<u>Subcontractor and Address of Office, Mill or Shops</u>	<u>Percent of Total Contract</u>	<u>DBE</u>	
				<u>YES</u>	<u>NO</u>
Item #16, 17 (partial)	757584	Global Road Sealing, Inc. 10641 Sycamore Ave., Stanton CA 90680	1%	Yes	
Items #11-14 (partial)	394471	Martinez Concrete, Inc. 920 W. Foothill Blvd., Azusa CA 91702	6%		No
Item #5, 7 (partial)	267073	All American Asphalt 400 E. Sixth St., Corona CA 92878-2229	11%		No
Item #15 (partial)	1087140	Interstate Striping, Inc. 9784 Poplar Ave., Fontana CA 92335	5%		No
Item 3 (partial)	LS 8133	On Point Land Surveying, Inc. 1906 Orange Tree Ln. #240 Redlands CA 92374	2%		No

Note: Do not list alternative subcontractors for the same work.

Contractor Copp Contracting, Inc.

BID SECURITY FORM

(Check to Accompany Bid)

(Note: The following form shall be used in case check accompanies bid.)

Accompanying this proposal is a *(Certified) *(Cashiers) check payable to the order of the City of La Habra, California, hereinafter referred to as "Owner", for

**MACY STREET REHABILITATION PROJECT
CITY PROJECT NO. 1-R-23**

In the amount of \$ N/A Dollars, this amount being ten percent (10%) of the total amount of the bid. The proceeds of this check shall become the property of said Owner provided this proposal shall be accepted by the said Owner through action if its legally constituted contracting authorities and the undersigned shall fail to execute a contract and furnish the required Performance and Payment Bonds and proof of insurance coverage within the stipulated time; otherwise, the check shall be returned to the undersigned. The proceeds of this check shall also become the property of the Owner if the undersigned shall withdraw his bid within the period of forty-five (45) days after the date set for the opening thereof unless otherwise required by law and notwithstanding the award of the Contract to another bidder.

Bidder

*Delete the inapplicable word.

NOTE: If the bidder desires to use a bond instead of a check, the Bid Bond form on the following pages shall be executed. The sum of this bond shall be not less than ten percent (10%) of the total amount of the bid.

BID BOND

KNOW ALL MEN BY THESE PRESENTS:

That we _____ Copp Contracting, Inc. _____ as principal and
Contractors Bonding and Insurance Company _____ as surety, are held and firmly
bound unto the City of La Habra, California hereinafter referred to as "Owner", in the sum of
Ten percent of the total bid amount _____ Dollars (\$
10% _____) to be paid to the said Owner, its successors and assigns for which payment
well and truly to be made we bind ourselves, our heirs, executors, administrators, successors and
assigns, jointly and severally, firmly by these presents.

THE CONDITION OF THIS OBLIGATION IS SUCH that if the certain proposal of the above
bounden for the construction of Street Improvements as specifically set forth in documents entitled:

**MACY STREET REHABILITATION PROJECT
CITY PROJECT NO. 1-R-23**

all in accordance with the specifications and drawings on file at the offices of the City Clerk of the
City of La Habra, California and is not withdrawn within the period of sixty (60) days after the date
set for the opening of bids unless otherwise required by law and notwithstanding the award of the
Contract to another bidder and that if said proposal is accepted by the Owner through action of its
legally constituted contracting authorities and if the above bounden his heirs, executors,
administrators, successors and assigns shall duly enter into and execute a contract for such
construction and shall execute and deliver the required Performance and Payment Bonds and proof
of insurance coverage within ten (10) days (not including Saturdays, Sundays and Holidays) after
the date of notification by and from the said Owner that the said contract is ready for execution, then
this obligation shall become null and void; otherwise, it shall be and remain in full force and virtue.

IN WITNESS WHEREOF, we hereunto set hands and seal this _____ 10th _____

day of _____ April _____, 2025.

Contractors Bonding and Insurance Company



Ryan Butterfas, Attorney-in-Fact

SURETY

Copp Contracting, Inc.



Ezekiel A Copp, President

BIDDER

NOTE: The standard printed bond form of any bonding company acceptable to the Owner may be used in
lieu of the foregoing approved sample bond form provided the security stipulations protecting the
Owner are not in any way reduced by use of the Surety Company's printed standard form.

CALIFORNIA ALL-PURPOSE ACKNOWLEDGMENT

CIVIL CODE § 1189

A notary public or other officer completing this certificate verifies only the identity of the individual who signed the document to which this certificate is attached, and not the truthfulness, accuracy, or validity of that document.

State of California)
County of Orange)
On April 15, 2025 before me, Yolanda Lujan - Notary Public,
Date Here Insert Name and Title of the Officer
personally appeared Ezekiel A Copp
Name(s) of Signer(s)

who proved to me on the basis of satisfactory evidence to be the person(s) whose name(s) is/are subscribed to the within instrument and acknowledged to me that he/she/they executed the same in his/her/their authorized capacity(ies), and that by his/her/their signature(s) on the instrument the person(s), or the entity upon behalf of which the person(s) acted, executed the instrument.

I certify under PENALTY OF PERJURY under the laws of the State of California that the foregoing paragraph is true and correct.

WITNESS my hand and official seal.

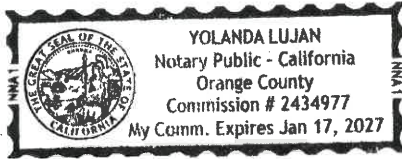

Signature [Handwritten Signature]
Signature of Notary Public

Place Notary Seal Above

OPTIONAL

Though this section is optional, completing this information can deter alteration of the document or fraudulent reattachment of this form to an unintended document.

Description of Attached Document

Title or Type of Document: Bid Bond Document Date: 04/10/2025

Number of Pages: _____ Signer(s) Other Than Named Above: _____

Capacity(ies) Claimed by Signer(s)

Signer's Name: _____

Corporate Officer — Title(s): _____

Partner — Limited General

Individual Attorney in Fact

Trustee Guardian or Conservator

Other: _____

Signer Is Representing: _____

Signer's Name: _____

Corporate Officer — Title(s): _____

Partner — Limited General

Individual Attorney in Fact

Trustee Guardian or Conservator

Other: _____

Signer Is Representing: _____

CALIFORNIA ALL-PURPOSE ACKNOWLEDGMENT

CIVIL CODE § 1189

A notary public or other officer completing this certificate verifies only the identity of the individual who signed the document to which this certificate is attached, and not the truthfulness, accuracy, or validity of that document.

State of California)
County of Orange)
On APR 10 2025 before me, Adelaide C. Hunter, Notary Public,
Date Here Insert Name and Title of the Officer
personally appeared Ryan Butterfas
Name(s) of Signer(s)

who proved to me on the basis of satisfactory evidence to be the person(s) whose name(s) is/are subscribed to the within instrument and acknowledged to me that he/she/they executed the same in his/her/their authorized capacity(ies), and that by his/her/their signature(s) on the instrument the person(s), or the entity upon behalf of which the person(s) acted, executed the instrument.

I certify under PENALTY OF PERJURY under the laws of the State of California that the foregoing paragraph is true and correct.

WITNESS my hand and official seal.

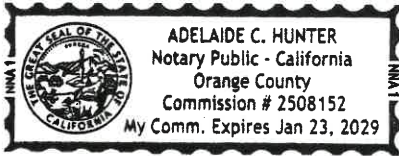

Signature *A. Hunter*
Signature of Notary Public

Place Notary Seal Above

OPTIONAL

Though this section is optional, completing this information can deter alteration of the document or fraudulent reattachment of this form to an unintended document.

Description of Attached Document

Title or Type of Document: _____ Document Date: _____

Number of Pages: _____ Signer(s) Other Than Named Above: _____

Capacity(ies) Claimed by Signer(s)

Signer's Name: _____

Corporate Officer — Title(s): _____

Partner — Limited General

Individual Attorney in Fact

Trustee Guardian or Conservator

Other: _____

Signer Is Representing: _____

Signer's Name: _____

Corporate Officer — Title(s): _____

Partner — Limited General

Individual Attorney in Fact

Trustee Guardian or Conservator

Other: _____

Signer Is Representing: _____

POWER OF ATTORNEY

RLI Insurance Company Contractors Bonding and Insurance Company

9025 N. Lindbergh Dr. Peoria, IL 61615
Phone: 800-645-2402

Know All Men by These Presents:

That this Power of Attorney is not valid or in effect unless attached to the bond which it authorizes executed, but may be detached by the approving officer if desired.

That **RLI Insurance Company** and/or **Contractors Bonding and Insurance Company**, each an Illinois corporation, (separately and together, the "Company") do hereby make, constitute and appoint:

Linda D. Coats, Matthew J. Coats, Summer Reyes, Ryan Butterfas, jointly or severally

in the City of Laguna Hills, State of California its true and lawful Agent(s) and Attorney(s) in Fact, with full power and authority hereby conferred, to sign, execute, acknowledge and deliver for and on its behalf as Surety, in general, any and all bonds and undertakings in an amount not to exceed Twenty Five Million Dollars (\$25,000,000.00) for any single obligation.

The acknowledgment and execution of such bond by the said Attorney in Fact shall be as binding upon the Company as if such bond had been executed and acknowledged by the regularly elected officers of the Company.

RLI Insurance Company and/or **Contractors Bonding and Insurance Company**, as applicable, have each further certified that the following is a true and exact copy of a Resolution adopted by the Board of Directors of each such corporation, and is now in force, to-wit:

"All bonds, policies, undertakings, Powers of Attorney or other obligations of the corporation shall be executed in the corporate name of the Company by the President, Secretary, any Assistant Secretary, Treasurer, or any Vice President, or by such other officers as the Board of Directors may authorize. The President, any Vice President, Secretary, any Assistant Secretary, or the Treasurer may appoint Attorneys in Fact or Agents who shall have authority to issue bonds, policies or undertakings in the name of the Company. The corporate seal is not necessary for the validity of any bonds, policies, undertakings, Powers of Attorney or other obligations of the corporation. The signature of any such officer and the corporate seal may be printed by facsimile."

IN WITNESS WHEREOF, the **RLI Insurance Company** and/or **Contractors Bonding and Insurance Company**, as applicable, have caused these presents to be executed by its respective Sr. Vice President with its corporate seal affixed this 19th day of March, 2024.



RLI Insurance Company
Contractors Bonding and Insurance Company

By: Eric Raudins
Eric Raudins Sr. Vice President

State of Illinois }
County of Peoria } SS

CERTIFICATE

On this 19th day of March, 2024, before me, a Notary Public, personally appeared Eric Raudins, who being by me duly sworn, acknowledged that he signed the above Power of Attorney as the aforesaid officer of the **RLI Insurance Company** and/or **Contractors Bonding and Insurance Company** and acknowledged said instrument to be the voluntary act and deed of said corporation.

I, the undersigned officer of **RLI Insurance Company** and/or **Contractors Bonding and Insurance Company**, do hereby certify that the attached Power of Attorney is in full force and effect and is irrevocable; and furthermore, that the Resolution of the Company as set forth in the Power of Attorney, is now in force. In testimony whereof, I have hereunto set my hand and the seal of the **RLI Insurance Company** and/or **Contractors Bonding and Insurance Company** this 10th day of April, 2025.

By: Jill A. Scott
Jill A. Scott Notary Public

RLI Insurance Company
Contractors Bonding and Insurance Company
By: Jeffrey D. Fick
Jeffrey D. Fick Corporate Secretary



JILL A. SCOTT
Notary Public
State of Ohio
My Comm. Expires
September 22, 2025

NON-COLLUSION AFFIDAVIT

FOR

**MACY STREET REHABILITATION PROJECT
CITY PROJECT NO. 1-R-23**

(TO BE EXECUTED BY EACH AWARDEE OF A PRINCIPAL CONTRACT)

STATE OF CALIFORNIA)
) SS.
)

_____ Ezekiel A. Copp _____, being first duly sworn,
deposes and says that he is _____ President _____
(sole owner, partner, president, secretary, etc.)

of _____ Copp Contracting, Inc. _____

The party making the foregoing bid; that such bid is not made in the interest of or on behalf of any undisclosed person, partnership, company, association, organization or corporation; that such bid is genuine and not collusive or sham: that said bidder has not directly or indirectly induced or solicited any other bidder to put in a false or sham bid, and has not directly or indirectly colluded, conspired, connived, or agreed with any bidder or anyone else to put in a sham bid, nor that anyone shall refrain from bidding; that said bidder has not in any manner directly or indirectly sought by agreement, communication or conference with anyone to fix the bid price of said bidder or of any other bidder, nor to fix any overhead, profit cost element of such bid price nor of that of any other bidder nor to secure any advantage against the public body awarding the contract or anyone interested in the proposed contract; that all statements contained in such bid are true; and, further, that said bidder has not directly or indirectly, submitted his bid price or any breakdown thereof, nor the contents thereof, nor divulged information or data relative thereto, nor paid and will not pay any fee in connection therewith to any corporation, partnership, company, association, organization, bid depository, nor to any member of agent thereof nor to any other individual except to such person or persons as have a partnership or other financial interest with said bidder in his general business.

Signed: _____ *E. A. Copp* _____

Title: Ezekiel A. Copp, President

Subscribed and sworn to before me
This _____ day of _____, 2025

See attached.

SEAL OF NOTARY PUBLIC

CALIFORNIA JURAT WITH AFFIANT STATEMENT

GOVERNMENT CODE § 8202

- See Attached Document (Notary to cross out lines 1-6 below)
- See Statement Below (Lines 1-6 to be completed only by document signer[s], *not* Notary)

Signature of Document Signer No. 1

Signature of Document Signer No. 2 (if any)

A notary public or other officer completing this certificate verifies only the identity of the individual who signed the document to which this certificate is attached, and not the truthfulness, accuracy, or validity of that document.

State of California
 County of Orange

Subscribed and sworn to (or affirmed) before me
 on this 15th day of April, 2025,
 by Ezekiel A Copp
 (1) _____
 (and (2) _____),

Name(s) of Signer(s)

proved to me on the basis of satisfactory evidence
 to be the person(s) who appeared before me.

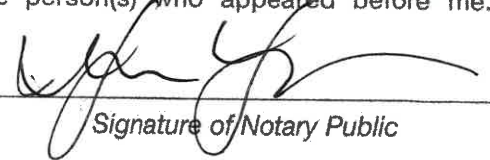
Signature 
Signature of Notary Public

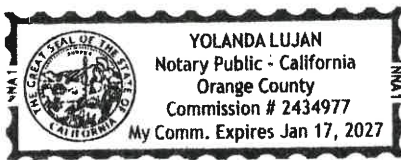

Seal
 Place Notary Seal Above

OPTIONAL

Though this section is optional, completing this information can deter alteration of the document or fraudulent reattachment of this form to an unintended document.

Description of Attached Document

Title or Type of Document: Non-Collusion Affidavit Document Date: _____

Number of Pages: _____ Signer(s) Other Than Named Above: _____

WORKER'S COMPENSATION CERTIFICATE

(AS REQUIRED BY SECTION 1861
OF THE CALIFORNIA LABOR CODE)

I am aware of the provisions of Section 3700 of the California Labor Code, which require every employer to be insured against liability for worker's compensation, or to undertake self-insurance in accordance with the provisions of said Code, and I will comply with such provisions before commencing the performance of the Work of this Contract.

Contractor Copp Contracting, Inc.

By 

Title Ezekiel A. Copp, President

Public Contract Code Section 10285.1 Statement

In conformance with Public Contract Code Section 10285.1 (Chapter 376, Stats. 1985), the bidder hereby declares under penalty of perjury under the laws of the State of California that the bidder **has** ____, **has not** been convicted within the preceding three years of any offenses referred to in that section, including any charge of fraud, bribery, collusion, conspiracy, or any other act in violation of any state or Federal antitrust law in connection with the bidding upon, award of, or performance of, any public works contract, as defined in Public Contract Code Section 1101, with any public entity, as defined in Public Contract Code Section 1100, including the Regents of the University of California or the Trustees of the California State University. The term "bidder" is understood to include any partner, member, officer, director, responsible managing officer, or responsible managing employee thereof, as referred to in Section 10285.1.

Note: The bidder must place a check mark after "has" or "has not" in one of the blank spaces provided. The above Statement is part of the Proposal. Signing this Proposal on the signature portion thereof shall also constitute signature of this Statement. Bidders are cautioned that making a false certification may subject the certifier to criminal prosecution.

Public Contract Code Section 10162 Questionnaire

In conformance with Public Contract Code Section 10162, the Bidder shall complete, under penalty of perjury, the following questionnaire:

Has the bidder, any officer of the bidder, or any employee of the bidder who has a proprietary interest in the bidder, ever been disqualified, removed, or otherwise prevented from bidding on, or completing a federal, state, or local government project because of a violation of law or a safety regulation?

Yes _____ No X

If the answer is yes, explain the circumstances in the following space.

Public Contract Code Section 10232 Statement

In conformance with Public Contract Code Section 10232, the Contractor, hereby states under penalty of perjury, that no more than one final unappealable finding of contempt of court by a federal court has been issued against the Contractor within the immediately preceding two year period because of the Contractor's failure to comply with an order of a federal court which orders the Contractor to comply with an order of the National Labor Relations Board.

Note: The above Statement and Questionnaire are part of the Proposal. Signing this Proposal on the signature portion thereof shall also constitute signature of this Statement and Questionnaire.

Bidders are cautioned that making a false certification may subject the certifier to criminal prosecution.



Contractor's License No. 384209 A

P.O. Box 457
Buena Park, CA. 90821-0457
714 522-7754
Fax 714 522-2074

MEETING OF THE BOARD OF DIRECTORS
OF
COPP CONTRACTING, INC.

A meeting of the Board of Directors of Copp Contracting, Inc., was held on January 6, 2014, during which a resolution was passed authorizing the following individual(s) to, by his/her signature(s) enter into any and all contracts on behalf of the corporation and, thereby, bind the corporation to such contract:

EZEKIEL A COPP - PRESIDENT

DENNIS W. COPP - VICE-PRES.

ERLINDA COPP - SEC-TREAS.

Attest:
(Seal)

ERLINDA COPP SEC.

**CITY OF LA HABRA
PUBLIC WORKS DEPARTMENT
ENGINEERING DIVISION**



110 E. LA HABRA BOULEVARD
LA HABRA, CA 90631
(562) 383-4151

**SPECIFICATIONS FOR
MACY STREET REHABILITATION PROJECT
CITY PROJECT NO. 1-R-23**

CITY MANAGER

JIM SADRO

LA HABRA CITY COUNCIL

MAYOR
MAYOR PRO TEM
COUNCIL MEMBER
COUNCIL MEMBER
COUNCIL MEMBER

ROSE ESPINOZA
JOSE MEDRANO
JAMES GOMEZ
DAREN NIGSAIAN
DELWIN LAMPKIN

BID OPENING: Tuesday, April 15, 2025, at 3:00 PM

**CITY OF LA HABRA
PUBLIC WORKS DEPARTMENT
ENGINEERING DIVISION**



110 E. LA HABRA BOULEVARD
LA HABRA, CA 90631
(562) 383-4151

**SPECIFICATIONS FOR
MACY STREET REHABILITATION PROJECT
CITY PROJECT NO. 1-R-23**

MARCH 2025

APPROVED BY:

**ALBERT MENDOZA, P.E.
DEPUTY DIRECTOR OF PUBLIC WORKS/CITY ENGINEER**

TABLE OF CONTENTS

<u>NOTICE INVITING BIDS</u>	A-1
<u>INSTRUCTION TO BIDDERS</u>	B-1
<u>SPECIAL PROVISIONS</u>	C-1
SECTION 1. DEFINITION OF TERMS	C-2
SECTION 2. REQUIREMENTS AND CONDITIONS	C-3
SECTION 3. SCOPE OF WORK	C-7
SECTION 4. CONTROL OF THE WORK	C-8
SECTION 5. CONTROL OF MATERIAL	C-12
SECTION 6. LEGAL RELATIONS AND RESPONSIBILITIES	C-14
SECTION 7. PROSECUTION AND PROGRESS	C-22
SECTION 8. PAYMENTS	C-23
SECTION 9. WORK SCHEDULES	C-24
SECTION 10. CITY REQUIREMENTS	C-24
SECTION 11. CONSTRUCTION DETAILS	C-26
SECTION 12. BID ITEMS FOR MACY ST. REHABILITATION PROJECT	C-35
<u>PROPOSAL</u>	D-1
PROPOSAL	D-2
BIDDER'S INFORMATION	D-5
EXHIBIT A, BID SCHEDULE 1	D-6
ACKNOWLEDGEMENT OF ADDENDA RECEIVED	D-9
REFERENCES	D-10
DBE BIDDER'S LIST	D-12
VIOLATIONS OF FEDERAL, STATE, OR LOCAL LAWS	D-13
DISQUALIFICATION OR DEBARMENT	D-14
LIST OF SUBCONTRACTORS	D-15
BID SECURITY FORM	D-16
BID BOND	D-17
NON-COLLUSION AFFIDAVIT	D-18
WORKER'S COMPENSATION CERTIFICATE	D-19
PUBLIC CONTRACT CODE SECTION 10285.1 STATEMENT	D-20
PUBLIC CONTRACT CODE SECTION 10162 QUESTIONNAIRE	D-21
PUBLIC CONTRACT CODE SECTION 10232 STATEMENT	D-22
<u>SAMPLE AGREEMENT</u>	E-1
ARTICLE I	E-2
ARTICLE II	E-2
ARTICLE III	E-3
ARTICLE IV	E-5
ARTICLE V	E-10
ARTICLE VI	E-12
FAITHFUL PERFORMANCE BOND	E-17

PAYMENT BOND
CERTIFICATION OF COMPLIANCE

E-19
E-21

APPENDIX "A", PROJECT PLANS
APPENDIX "B", STANDARD PLANS

SECTION A

NOTICE INVITING BIDS

CITY OF LA HABRA

NOTICE INVITING BIDS

NOTICE IS HEREBY GIVEN that sealed bids will be received by the City Clerk of the City of La Habra, California for furnishing all labor, services, materials, tools, equipment, supplies, transportation, utilities and all other items and facilities necessary therefor as provided in the Contract Documents for the: **MACY STREET REHABILITATION PROJECT, CITY PROJECT NO. 1-R-23** in strict compliance with the specifications, plans and contract documents on file at the Office of the City Clerk of the City of La Habra.

DATE OF OPENING BIDS: Bids will be received at the Office of the City Clerk of the City of La Habra until **3:00 P.M. on Tuesday, April 15, 2025**, at which time and place the bids will be publicly opened and read aloud. Bids shall be submitted in sealed envelopes marked on the outside: **“MACY STREET REHABILITATION, CITY PROJECT NO. 1-R-23. DO NOT OPEN WITH REGULAR MAIL.”**

LOCATION OF WORK: The work to be constructed hereunder is shown attached as APPENDIX “A” and on the plans. Typical work to be done is illustrated on the plans.

DESCRIPTION OF WORK: The work comprises the furnishing of all materials, equipment, tools, labor and incidentals as required by the Plans, Specifications and Contract Documents for the above stated project. The general items of work to be performed hereunder consist of but not be limited to **Mobilization/Demobilization; Traffic Control, Safety and Cleanup; Construction Staking and Monument Perpetuation; Storm Water Best Management Practices (BMPs); Crack Sealing; Unclassified Excavation and Disposal, Construct Rubberized AC pavement Overlay, Cold mill and Dispose of Existing Asphalt; Remove and Dispose of Existing Asphalt; Construct Concrete Curb and Gutter, and Driveways over CMB with AC Slot Trench; Sawcut and Remove Sidewalk and Ramp and Construct Curb Ramp with Detectable Warning Surface; Traffic Striping, Crosswalks, Curb Painting, Markings, and Raised Pavement Markers; Traffic Signal Loop Detectors; Adjust to Grade Valves, Manhole Covers; Pull Boxes, and Water Meter Boxes; Coordinate with Utilities for Adjust to Grade by Others; Grind Tree Roots; and all incidental work so indicated on the specifications, and required for the proposed improvements.**

CONTRACTOR’S LICENSE: The City of La Habra has determined that a Class “A” Contractor’s License is required for this project.

COMPLETION OF WORK: All work shall be completed within Thirty (30) working days from the start date specified in the Notice To Proceed.

LIQUIDATED DAMAGE: If the total amount of working days have expired and the work is not complete, liquidation damages are Five Hundred Dollars (\$500) per calendar day.

AWARD OF CONTRACT: The City of La Habra reserves the right, after opening the bids, to reject any or all bids, waive any informality or irregularity in such bids, or to award to the lowest responsible bidder and reject all other bids.

PROPOSAL GUARANTEE AND BONDS: Each bid must be accompanied by a certified cashier's check or by a corporate surety bond on the form furnished by the City of La Habra, as guarantee that the bidder will, if an award is made to him in accordance with the terms of his bid, promptly secure Worker's Compensation Insurance and Liability Insurance, execute the contract in the required form and furnish satisfactory bonds for the faithful performance of the contract and for the payment of claims of materialmen and workers thereunder. Said check or bidder's bond shall be in an amount of not less than ten percent (10%) of the amount of the bid. The Faithful Performance Bond shall be not less than one hundred percent (100%) of the total amount of the bid price named in the contract. The Payment Bond shall be not less than one hundred percent (100%) of the total amount of the bid price named in the contract. The City of La Habra reserves the right to reject any bond if, in the opinion of the Engineer, the Surety's acknowledgment is not in the form included in the contract documents or in another form substantially as prescribed by law.

PREVAILING RATES OF WAGES: Pursuant to the provisions of Section 1773 of the Labor Code of the State of California, the Director of Industrial Relations has ascertained the general prevailing rate of wages and employer payments for health and welfare, vacation, pension and similar purposes applicable to the work to be done. A copy of said wage rates is available on-line at:

<https://www.dir.ca.gov/dlsr/DPreWageDetermination.htm>

The Contractor and all subcontractors are responsible to pay the prevailing rates of wages that are specified within ten (10) calendar days before the bid open day and shall post a copy of said wage rates at the project site. The statutory provisions for penalties for failure to pay prevailing wages will be enforced (Labor Code §1775) and the statutory provisions for failure to comply with the States' wage and hour laws will be enforced (Labor Code §1813).

DEBARMENT: No Contractor or Subcontractor may be awarded as a contractor on a bid proposal if they have been Debarred by the State pursuant to Labor Code Sections 1777.1 and 1777.7 and Public Contracts Code Section 6109.

APPRENTICE: The Contractor shall comply with all laws, rules, regulations, and all the requirements of the Labor Code including, but not limited to, Section 1776, 1777.5, and 1777.6 of the California Labor Code.

CONTRACT DOCUMENTS: The Contract Documents shall consist of the following: Notice Inviting Bids; Instructions to Bidders; Proposal; Bidder's Information; Bid Schedule; Acknowledgement of Addenda Received; References; DBE Bidder's List; Violations of Federal, State, or Local Laws; Disqualification or Debarment; List of Subcontractors; Bid Security Form; Bid Bond; Non-Collusion Affidavit; Worker's Compensation Certificate; Public Contract Code Section 10285.1 Statement; Public

Contract Code Section 10162 Questionnaire; Public Contract Code Section 10232 Statement; Agreement; Faithful Performance Bond; Payment Bond; Certification of Compliance; Special Provisions; Drawings; and the Standard Specifications for Public Works Construction, latest edition and supplements thereto, made a part by reference, together with all additions, deletions, modifications or interpretations of any of said documents, all of which are hereby made a part of this Notice Inviting Bids.

Specifications are available for inspection, without charge, at the Office of the City Engineer of the City of La Habra.

Complete sets of said plans, specifications, and bid documents can be downloaded at PlanetBids.com.

ADDRESS AND MARKING OF PROPOSAL: The envelope enclosing the proposal shall be sealed and addressed to the City Clerk and hand delivered to the City Clerk at the Civic Center, 110 E. La Habra Blvd (Administration Department), or mailed to City Clerk, Civic Center, 110 E. La Habra Blvd, La Habra, California 90631. The envelope shall be plainly marked in the upper left-hand corner with the name and address of the bidder and shall bear the words "Proposal For" followed by the title of the specifications for the work, and the date and hour of opening bids. The certified or cashier's check, money order, or bidder's bond shall be enclosed in the same envelope with the proposal.

DEPARTMENT OF INDUSTRIAL RELATIONS (DIR) REQUIREMENT: No Contractor or Subcontractor may be listed on a bid proposal for a public works project unless registered with the Department of Industrial Relations (DIR) pursuant to Labor Code 1725.5 and Senate Bill 854. Payroll documents for the contractor and subcontractors should be submitted and registered on time with the DIR.

Under California Labor Code Section 1771.1, in order to be awarded and to perform work on public works projects, prime contractors and subcontractors must possess and maintain registration with the Department of Industrial Relations (DIR) at <https://www.dir.ca.gov/public-works/contractor-registration.html>. This is a separate requirement from the Contractors State License Board (CSLB) licensing requirement. See the Special Provisions for additional details.

SUBMISSION OF QUESTIONS:

- Questions received after Monday, March 31, 3:00 pm will not be considered.
- Questions or clarifications deemed by the City's to be material change will be answered via issuance of an addendum and posted to the City's online bidding service, PlanetBids.com.
- Only questions answered by formal written addenda shall be binding. Oral and other interpretations or clarifications shall be without legal effect. It is the Bidder's responsibility to be informed of any issued addenda and to include all such information in its Bid.
- Any questions regarding this solicitation shall be submitted electronically to Andrew Luna at anluna@lahabracalifornia.gov.

BID SCHEDULE:

Bid AdvertisementThursday, March 24, 2025
Requests for InformationMonday, March 31, 2025, by 3:00 pm
Response to Requested for Information.....Thursday, April 3, 2025, by 5:00 pm
Bid Opening.....Tuesday, April 15, 2025, 3:00 pm

SECTION B

INSTRUCTIONS TO BIDDERS

CITY OF LA HABRA

INSTRUCTIONS TO BIDDERS

The following instructions and conditions apply to the attached bid and the bidder acknowledges the acceptance thereof by signing and filing said bid.

Each bidder shall state whether he is an individual, firm or corporation; if firm, give name of each member; if a corporation, give name of president, secretary, treasurer and manager.

Proposals shall be submitted to the City of La Habra on forms prepared and furnished in the bid documents, or as provided by the Engineering Office of the City of La Habra. When presented, they must be completely made out in the manner and form indicated therein, showing the proposed prices clearly and legibly and must be properly signed by the bidder. Proposals presented otherwise may be rejected.

Each proposal so submitted, together with the required proposal guarantee hereinafter prescribed, shall be presented under sealed cover and must be filed prior to the time and place designated in the Notice Inviting Bids. A proposal so presented, however, may be withdrawn by the bidder provided the request therefor is made in writing, is signed by the bidder or his authorized representative and is filed prior to the time fixed for the opening of bids. The withdrawal of a bid proposal does not prejudice the right of the bidder to file a new bid.

All proposals submitted as hereinabove prescribed will be publicly opened and read at the time and place indicated in the Notice Inviting Bids.

Bids are required for the entire work. The amount of the bid for comparison purposes will be the total of all items.

The bidder shall set forth for each item of work, in words and in clearly legible figures, a unit price and an amount for the item in the respective space provided for this purpose. In the case of unit price items, the amount set forth under the "AMOUNT" column shall be the extension of the unit price bid on the basis of the estimated quantity for the item. In case of discrepancy between the words and figures, the words shall prevail.

In case of discrepancy between the "Unit Price" and the "Amount" set forth for the item, the Unit Price shall prevail. However, if the amount set forth as a Unit Price is ambiguous, unintelligible or uncertain for any cause or is omitted or in the case where the Unit Price is the same amount as the entry in the "AMOUNT" column for the item, the "AMOUNT" price shall prevail in accordance with the following:

- (1) As to lump sum items, the amount set forth in the "AMOUNT" column shall be the unit price.
- (2) As to unit price items, the amount set forth in the "AMOUNT" column shall be divided by the estimated quantity for the item and the price thus obtained shall be the unit price.

In case of discrepancy between the sum of the individual “AMOUNT” prices, and the Total Bid Price, the sum of the individual “AMOUNT” prices will prevail.

Bidders must satisfy themselves by personal examination of the location of the proposed work and by personal examination of the proposed contract documents as to the actual conditions and the requirements of this work and shall not at any time after submission of the bid dispute, complain or assert that there was any misunderstanding in regard to the nature or the amount of work to be done unless a written change in these specifications or contract or written clarification thereof has been issued by the City of La Habra.

Each bid must be in a sealed envelope which is to be clearly marked so as to identify it as a bid (such as “Sealed Bid - do not open with regular mail”), giving the number and name of the project or specification and the name of the bidder. These instructions are particularly necessary if your bid is transmitted by mail. Failure to identify the project or to address it to the City Clerk, Civic Center, 110 E. La Habra Blvd, La Habra, California 90631, Attention City Clerk, will result in the opening of the envelopes with the regular mail and may thereby void the bid.

The City Council will award the contract to the lowest responsible bidder, however, said Council reserves the right to reject any or all bids, to waive any informality in the bids received and, if necessary, to take said bids under advisement for a period not to exceed sixty (60) days including lead-time.

All proposal requirements and conditions as set forth in the Standard Specifications shall apply hereto.

APPROXIMATE ESTIMATE: The quantities shown in the proposal form and in the estimate included in the bid documents shall be considered as approximate only, being listed therein for the purpose of serving as a general indication of the amount of work or materials to be performed or furnished as a basis for the comparison of bids. The Council does not guarantee nor agree, either expressly or by implication, that the actual amounts required will correspond therewith, but reserves the right to increase or decrease the amount of any item, portion of work to be performed or material to be furnished, or to omit any such item or portion, in accordance with the provisions relative thereto set forth in the bid documents or Standard Specifications under which the work is to be constructed, without in any way invalidating the contract should such increase, decrease or omission be deemed necessary or expedient. The City of La Habra reserves the right to increase or decrease the amount of any item as necessary due to budgetary requirements.

DISADVANTAGED BUSINESS ENTERPRISE (DBE) REQUIREMENTS: The City of La Habra requires that Disadvantaged Business Enterprises (DBEs) have the opportunity to participate in public works projects. To assist the City of La Habra in establishing future Annual Anticipated DBE Participation Level (AADPL), all contractors are required to submit a list of all subcontractors and suppliers, whether DBE or not, contacted during preparation of the bid.

SECTION C
SPECIAL PROVISIONS

SPECIAL PROVISIONS

SECTION 1. DEFINITION OF TERMS

CITY: The City of La Habra

CITY COUNCIL: The City Council of the City of La Habra.

ENGINEER: Any reference to the “Engineer” in the specifications shall be construed to mean the City Engineer of the City of La Habra or his authorized agents.

BIDDER: Any individual, firm or corporation submitting a bid to furnish the materials and equipment and perform the work herein specified, properly made out on the form furnished by the City Engineer, duly executed by the bidder and enclosed within a sealed envelope directed to the City Clerk, Civic Center, 110 E. La Habra Blvd., La Habra, California 90631.

BID FORMS: The blank forms prepared by the City of La Habra on which the bidder must submit the bid.

CONTRACTOR: The bidder whose bid is accepted and to whom the contract is awarded.

CONTRACT: The Specifications, Special Provisions, the notice inviting bids, the bid and addenda of the Contract, and the agreement entered into pursuant thereto shall constitute the Contract between the City of La Habra and the Contractor.

LABORATORY: The designated laboratory authorized by the Engineer to test materials and work involved in the contract.

THE WORK: All the work required to be performed under the contract.

GENERAL CONSTRUCTION TERMS: Unless otherwise specifically defined herein or unless the content requires a different meaning, all words, terms and phrases having a well-known or technical meaning shall be so construed.

USE OF PRONOUNS: Words used herein in the masculine gender include the feminine and neuter and vice versa; the singular number includes the plural and the plural the singular. The word “person” includes a corporation, association or partnership.

SECTION: The part into which these Special Provisions are divided. Each section is designated by a whole number preceding its title.

ARTICLES: The parts into which sections are divided. Each article is designated by a number preceding its title, the first two figures to the right of the decimal point being the number of the article and the figures or figure to the left of the decimal point being the number of the section of which such article is a part. Thus: Article 11.05 indicates Article 5 of Section 11.

SUBDIVISIONS: The parts into which articles are divided. Each subdivision is designated by a number preceding its title, the figure or figures to the right of the article number being the number of the subdivision. Thus: Subdivision 11.05.2 indicates Subdivision 2 of Article 5 of Section 11.

STANDARD SPECIFICATIONS: The document entitled “Standard Specifications for Public Works Construction”, latest edition and supplements thereto, are hereinafter referred to as the Standard Specifications.

Other terms appearing in the Standard Specifications shall have the intent and meaning specified in Section 1 “General” of the Standard Specifications.

In case of conflict between the Standard Specifications and these Special Provisions, these Special Provisions shall take precedence over and be used in lieu of such conflicting portions of the Standard Specifications.

SECTION 2. REQUIREMENTS AND CONDITIONS

ARTICLE 2.01: EXAMINATION OF PLANS, SPECIFICATIONS, SPECIAL PROVISIONS, AND WORKSITE: Bidders must satisfy themselves by personal examination of the proposed work site and by such other means as they may prefer as to the actual conditions and requirements of the work. Bidders shall not at any time after submission of the bid, dispute, complain or assert that there was any misunderstanding in regard to the nature or amount of work to be done.

The CITY, in accordance with Title VI of the Civil Rights Act of 1964 (78 Stat 252) and the Regulations of the Department of Commerce (15 C.F.C., Part 8), issued pursuant to such Act, hereby notifies all bidders that it will affirmatively insure that the contract entered into pursuant to this advertisement will be awarded to the lowest responsible bidder without discrimination of the grounds of race, color or national origin.

ARTICLE 2.02 BID FORMS: All bids submitted shall be made on the blank forms provided with the bid documents. Bids submitted on forms other than those provided with the bid documents shall be rejected. All bids shall give the price bid both in writing and figures and shall be signed by the bidder with his address. Bids shall be enclosed in a sealed envelope directed to the City Clerk, Civic Center, 110 E. La Habra Blvd, La Habra, California 90631.

ARTICLE 2.03 IRREGULAR BIDS: Bids may be rejected if they show any alterations of form, additions not called for, conditional bids, incomplete bids, erasures or irregularities of any kind.

ARTICLE 2.04 DISQUALIFICATION OF BIDDERS: The CITY COUNCIL may reject any and all bids should it deem this for the public good and the bid of any party who has been delinquent or unfaithful in any former contract with the CITY, and may reject all bids

other than the lowest bid of any responsible bidder and may award the contract for said work or improvement to the lowest responsible bidder at the prices named in his bid.

ARTICLE 2.05 MATERIAL GUARANTEE: Before any bid is accepted, the bidder may be required to furnish a complete statement of the origin, composition and manufacture of any or all materials to be used in the construction of the work, together with samples which may be subjected to the tests provided for in these Specifications or in the Special Provisions to determine their quality and fitness for the work.

ARTICLE 2.06 BONDS: In lieu of Section 1-7.2 “Contract Bonds” of the Standard Specifications, the Contractor, simultaneously with the execution of the Agreement, shall furnish a surety bond in an amount equal to one hundred (100) percent of the contract price as security for the faithful performance of the contract and a separate surety bond in an amount equal to one hundred (100) percent of the contract price as security for the payment of all persons performing labor and furnishing materials in connection with the contract. Said bonds shall be secured from a Surety Company satisfactory to the CITY.

ARTICLE 2.07 BID GUARANTEE:

Subdivision 2.07.1: All bids shall be presented under sealed cover and shall be accompanied by cash, cashier’s check, certified check or bidder’s bond made payable to the City of La Habra for an amount equal to at least ten percent (10%) of the amount of said bid. No bid will be considered unless such cash, cashier’s check, certified check or bidder’s bond is enclosed therewith.

Subdivision 2.07.2: Return of Bid Guarantee: The bid guarantee of the bidder or bidders who are being considered for the award of Contract shall be held until the execution of said contract, and shall thereupon be returned to the bidder. Bid guarantee of other bidders will be returned to such bidders upon award of the Contract.

ARTICLE 2.08 AWARD OF CONTRACT: The award of contract, if it be awarded, will be within sixty (60) days of the opening of bids.

ARTICLE 2.09 EXECUTION OF CONTRACT: The contract, construction schedule, and bonds shall be executed and filed by the successful bidder with the City Clerk of the City of La Habra not later than ten (10) days after the award of contract.

All bidders may submit with their bids a sworn statement of their financial responsibility, technical ability and experience. Such sworn statement may be required to be furnished before award is made to any particular bidder.

The CITY COUNCIL may, upon the refusal or failure of successful lowest responsible bidder to accept the contract, award it to the second lowest responsible bidder. If the legislative body awards the contract to the second lowest bidder, the amount of the lowest bidder’s security shall be applied by the CITY to the difference between the low bid and the second lowest bid; and the surplus, if

any, shall be returned to the lowest bidder if cash or a check is used, or to the surety company if bidder's bond is used.

ARTICLE 2.10 BEGINNING OF WORK: The Contractor shall begin work from the start date specified in the Notice To Proceed.

ARTICLE 2.11 PLANS AND SPECIFICATIONS: Specifications and bid documents are on file at the Office of the City Engineer, Civic Center, 110 E. La Habra Blvd., La Habra and can be downloaded as a digital copy of said Contract Documents (saved in PDF format) are available free of charge posted at the following website:

<http://www.PlanetBids.com/>

ARTICLE 2.12 CONTRACT DOCUMENTS: The Contract Documents shall consist of the following: Notice Inviting Bids; Instructions to Bidders; Proposal; Bidder's Information; Bid Schedule; Acknowledgement of Addenda Received; References; DBE Bidder's List; Violations of Federal, State, or Local Laws; Disqualification or Debarment; List of Subcontractors; Bid Security Form; Bid Bond; Non-Collusion Affidavit; Worker's Compensation Certificate; Public Contract Code Section 10285.1 Statement; Public Contract Code Section 10162 Questionnaire; Public Contract Code Section 10232 Statement; Agreement; Faithful Performance Bond; Payment Bond; Certification of Compliance; Special Provisions; Drawings; and the Standard Specifications for Public Works Construction, latest edition and supplements thereto, together with all additions, deletions, modifications, appendices and all addenda as prepared prior to the date of the bid opening setting forth any modifications or interpretations of any said documents are hereby incorporated in and made a part of the Contract Documents.

All Contract Documents are complementary, and what is called for in any one shall be as binding as if called for in all. The intention of the documents is to require a complete and finished piece of work. The Contractor, at his sole cost and expense, shall perform all labor and services and shall furnish all materials, tools, equipment and facilities necessary for the proper execution of the work, with the exception of such items as may be definitely stipulated in the Specifications or on the Plans to be furnished by the CITY. Anything shown on the Plans and not in the Specifications, or in the Specifications and not in the Plans, shall be performed by the Contractor as though shown on both the Plans and Specifications.

Documents which shall be signed and returned to the CITY with Bid Proposal are:

Proposal; Bidder's Information; Bid Schedule; Acknowledgement of Addenda Received; References; DBE Bidder's List; Violations of Federal, State or Local Laws; Disqualification or Debarment; List of Subcontractors; Bid Security Form; Bid Bond; Non-Collusion Affidavit(s) (Principal and Subcontractor); Worker's Compensation Certificate; Public Contract Code Section 10285.1 Statement; Public Contract Code Section 10162 Questionnaire; and Public Contract Code Section 10232 Statement.

Documents which are to be signed and returned to the CITY by the winning bidder are:

Agreement; Faithful Performance Bond; Labor and Material Payment Bond; Supplemental Information to Be Completed by Principal; Tax Identification Number; Bid Guarantee; Statement of Non-Collusion by Contractor; Certification of Compliance; Liability Insurance; and Workers Compensation Insurance.

Subdivision 2.12.1 Precedence Of Contract Documents: If there is a conflict between Contract Documents, the order of precedence shall be as follows:

1. Contract
2. Specifications
3. Plans

Within the Specifications, the order of precedence is as follows:

1. Change Orders
2. Addenda
3. Permits from other agencies/Supplemental Agreements
4. Special Provisions
5. Instructions to Bidders
6. Notice Inviting Bids
7. Referenced Standard Drawings
8. Referenced Standard Specifications

With reference to Plans, the order of precedence is as follows:

1. Change Order drawings govern over Addenda and Contract drawings.
2. Addenda drawings govern over contract drawings.
3. Contract drawings govern over shop drawings and Standard drawings.
4. Detail drawings govern over general drawings.
5. Figures govern over scaled dimensions.

ARTICLE 2.13 AUTHORITY OF THE ENGINEER: The Engineer shall have the authority to direct as may be necessary to ensure that the work is in strict compliance with the Contract Documents; determine the quantity, quality and soundness of the work; determine if material and equipment being used is satisfactory; interpret the requirements of the contract; and, make decisions regarding the progress and execution of the work. However, neither the Engineer nor any representative of the Engineer shall have the authority to authorize extra work without prior approval by the CITY COUNCIL. Should any discrepancy appear or any misunderstanding arise as to the importance of anything contained in the Specifications or Plans, the matter shall be referred to the Engineer, who shall decide the same in accordance with the true intent and meaning as construed by him. Any difference or conflicts which may arise between the Contractor and any other contractor also under the contract administration of the Engineer shall be arbitrated by the Engineer.

ARTICLE 2.14 ACCESS TO WORK: The Engineer, his agents and duly authorized representatives of the CITY shall at all times and for any purpose, have access to the work and the premises used by the Contractor and the Contractor shall provide safe and proper facilities therefor.

ARTICLE 2.15 LEGAL ADDRESS OF THE CONTRACTOR: The address given in the Proposal is hereby designated as the place to which all notices, letters and other communications to the Contractor shall be mailed or delivered. The mailing or delivering to the above-named place of any notice, letter or other communication to the Contractor, shall be deemed sufficient service thereof upon the Contractor. The date of said service shall be the date of such mailing or delivery. Such address may be changed at any time by a written notice signed by the Contractor and delivered to the Engineer.

ARTICLE 2.16 CONTRACTOR'S RESPONSIBILITIES: The Contractor shall be responsible for the safe, efficient and adequate use of equipment during the progress of the work so as to secure the safety of the workers and others. The Contractor is also responsible for the quality of work required and the stipulated rate of progress. It shall be the Contractor's responsibility to perform the work strictly in accordance with the Specifications and Plans or in accordance with modifications as may be made by the Engineer in the form of addendum or written change orders. The presence of the Public Works Inspector does not relieve the Contractor of his obligation to comply with the requirements of the Plans, Specifications and Contract Documents.

The Contractor shall assume the defense of and indemnify and save harmless the CITY and its officers and agents from all claims of any kind arising from his own negligence or that of his agents in the performance of the Contract.

The Contractor shall be responsible for the custody of any material furnished to him for the care of all work until its completion and final acceptance. He shall, at his own expense, replace damaged or lost material and repair damaged parts of the work, regardless of cause, or the same may be done at the Contractor's expense by the CITY.

During the progress of the work the Contractor shall keep the worksite in a neat and clean condition and free from any unsightly accumulation of rubbish. If stockpiling is necessary, the material shall be removed or disposed of weekly. He shall remove from the vicinity of the completed work all plant, building, rubbish, unused materials, concrete forms and equipment belonging to him or used under his direction during construction. In the event of his failure to do so, the same may be removed by the CITY at the Contractor's expense.

All operations of the Contractor shall be conducted in such a manner as to avoid unnecessary dust. To this end, the Contractor shall provide equipment, materials, water, and labor to keep all parts of the work adequately sprinkled and dust free as determined by the Engineer. Full compensation for dust control measures and conforming with the provisions of this Section shall be included in the prices paid for the various contract items of work listed in the Bid Schedule, and no additional compensation will be allowed therefor.

SECTION 3. SCOPE OF WORK

ARTICLE 3.01 WORK TO BE DONE: The Contractor shall for the price bid furnish all the necessary labor, materials, equipment, methods, processes, implements, tools, and machinery except as otherwise specified to perform the required work in a thorough and workmanlike manner in accordance with the plans and specifications, and to the satisfaction of the Engineer.

The general items of work to be performed hereunder consist of but not be limited to

Mobilization/Demobilization; Traffic Control, Safety and Cleanup; Construction Staking and Monument Perpetuation; Storm Water Best Management Practices (BMPs); Crack Sealing; Unclassified Excavation and Disposal, Construct Rubberized AC pavement Overlay, Cold mill and Dispose of Existing Asphalt; Remove and Dispose of Existing Asphalt; Sawcut, Remove Existing, and Construct Concrete Curb and Gutter, and Driveways over CMB with AC Slot Trench; Sawcut and Remove Sidewalk and Ramp and Construct Curb Ramp with Detectable Warning Surface; Traffic Striping, Crosswalks, Curb Painting, Markings, and Raised Pavement Markers; Traffic Signal Loop Detectors; Adjust to Grade Valves, Manhole Covers; and Pull Boxes; Coordinate with Utilities for Adjust to Grade by Others; Grind Tree Roots; and all incidental work so indicated on the specifications, and required for the proposed improvements.

ARTICLE 3.02 FINAL CLEANING UP: Before acceptance of the work and final payment therefor, the Contractor shall clean the work and all ground occupied by him in connection with the work, of all rubbish, excess materials, equipment and forms. All parts of the work shall be left in a neat and presentable condition.

ARTICLE 3.03 REPAIRS AND REPLACEMENTS: All damage done to existing facilities and improvements by the Contractor shall be repaired by him to the satisfaction of the Engineer. Where sidewalks, curbs or gutters are to be repaired, the repairs shall be made by removing and replacing the entire section back to the nearest scoring lines and not by refinishing the damaged portion.

SECTION 4. CONTROL OF THE WORK

ARTICLE 4.01 COORDINATION OF PLANS, SPECIFICATIONS AND SPECIAL PROVISIONS: These specifications, drawings, special provisions and all supplementary documents are essential parts of the contract. A requirement occurring in one is as binding as though occurring in all. The drawings and specifications are intended to be cooperative and to describe and provide for the workmanlike completion of proposed improvements. Refer to Subdivision 2.12.1 for precedence of Contract Documents.

ARTICLE 4.02 SPECIFICATIONS AND DRAWINGS: The Contractor shall keep at the work site a copy of the Specifications and Plans at all times and provide the Engineer access thereto.

The Contractor shall check all dimensions and quantities on the drawings or schedules herein contained or given to him by the Engineer, and shall notify the Engineer of errors therein which may be discovered by examining and checking the drawing. He shall not take advantage of any error or omission in these specifications, drawings or schedules, but should such error or omission be discovered, the Contractor shall notify the Engineer and the Contractor shall carry out the Engineer's instructions, as if originally specified.

ARTICLE 4.03 SUPERVISION BY THE CONTRACTOR: The Contractor shall give his personal superintendence to the work, using all his skills and attention in directing the performance of the work or he shall provide a competent, full-time superintendent or foreman with the authority to act on his behalf and whom shall be present to direct the work on the project at all times during its progress. All directions given to the Contractor's superintendent or other authorized supervisory employee shall be as binding as if delivered to the Contractor personally.

ARTICLE 4.04 LABOR: Any overseer, superintendent, laborer or other person employed by the Contractor who shall perform his work in a manner contrary to the specifications shall be discharged immediately and such person shall not again be employed on the project.

ARTICLE 4.05 LINES AND GRADES: The Contractor will set all lines and grades in accordance with the plans and all work done shall conform thereto. The Contractor shall dig all stake holes necessary to give lines and grades. The Contractor shall preserve all stakes set for lines, grades or measurements of the work in their proper places until authorized to remove them by the Engineer. Any expense incurred in replacing stakes which the Contractor or his subordinates may have failed to preserve shall be borne by the Contractor. Unless otherwise noted, the grade between two grade points shall be a straight line between such two points.

ARTICLE 4.06 INSPECTION: The Contractor shall notify the Engineer at least 48 hours in advance of starting or resuming work so that the Engineer can arrange for an assistant engineer or inspector to be present. Failure to give such notice shall be cause for rejection of such work. The Contractor shall furnish the engineers and inspectors reasonable facilities for obtaining such information as may be necessary to give them full information at all times respecting the progress and manner of doing the work and the character of the materials.

Subdivision 4.06.1 Special Inspection Fees: If the Contractor elects to work under this contract more than 8 hours per day and 40 hours per week; or Saturday, Sunday, overtime, or CITY Holidays, the Contractor shall arrange with the Engineer for the

required inspection service and pay the special inspections fees which will be charged at the following rates:

Monday through Friday	\$150.00 / hour
Saturday, Sunday, overtime and Holidays	\$200.00 / hour

ARTICLE 4.07 DEFECTIVE WORK OR MATERIALS: Inspection of the work shall not relieve the Contractor of his obligation to fulfill his duty as herein prescribed. Defective work shall be made good by the Contractor. Unsuitable work and materials may be rejected notwithstanding that such work and materials were previously inspected by the Engineer and accepted or estimated for payment. If the work, or any part thereof, is determined to be defective at any time before final acceptance of the work, the Contractor shall forthwith make good such defect without additional compensation in a manner satisfactory to the Engineer.

If materials furnished and brought upon the job site by the Contractor for use in the work, or selected for the same by him shall be condemned by the Engineer as unsuitable or not in conformity with the Specifications, the Contractor shall forthwith discard such materials and remove them to a satisfactory distance from the vicinity of the work.

If the Contractor fails or neglects to make ordered repairs to defective work, or to remove rejected materials from the work site within 10 days after notification by the Engineer, the Engineer acting on behalf of the CITY may make the ordered repairs or remove the condemned materials and deduct the cost thereof from monies due to the Contractor.

ARTICLE 4.08 EQUIPMENT AND PLANT: Equipment not suitable to produce the quality of work required will not be permitted to operate on the project.

Plants, tools and equipment shall be designed and constructed in accordance with general practice for such equipment and shall be of sufficient capacity and of such character to insure the production of sufficient material to take the work to completion within the scheduled time frame. The Contractor shall provide adequate and suitable equipment and plants to meet the above requirements and when ordered by the Engineer shall remove unsuitable equipment from the worksite and discontinue receiving materials from unsatisfactory plants.

ARTICLE 4.09 ADDITIONS OR OMISSIONS OF WORK, LABOR OR MATERIALS:

Subdivision 4.09.1: Additions: The Contractor shall make additional excavations, furnish and place additional imported borrow, plant-mixed surfacing, concrete or do other additional work or furnish other additional materials where the necessity for or the extent of such work or materials does not appear and cannot with reasonable diligence, cost and certainty, be determined in advance or will only be disclosed by the doing of the work or in any contingency which reasonable care and consideration could not be foreseen. Such additional work or materials

shall be specified in writing by the Engineer, subject to approval of the CITY COUNCIL, and shall be paid for at the unit prices set for in the contract.

Subdivision 4.09.2: Omissions: The Contractor shall omit any portion of the work, labor or materials required to be done or furnished under the plans and the specifications when the necessity for the omission of said work, labor or materials does not appear and cannot with reasonable certainty, diligence and cost be ascertained in advance or will only be disclosed by the doing of the work or in any contingency which reasonable care and consideration could be foreseen; which said omission of work, labor or materials shall be specified and required in writing by the Engineer, subject to the approval of the CITY COUNCIL, and shall be deducted from the contract price at the unit prices therefore set forth in said contract. Where the contract price is a lump sum, then the cost of the amount deducted shall be proportion of said lump sum such as the quantity of work, labor or materials omitted bears to the quantity upon which said lump sum is based.

Subdivision 4.09.3: Mark-Ups For Extra Work: The Contractor shall use the specified mark ups for all approved extra work:

For General Contractor's work, 15% mark-up for materials and equipment; and 20% mark-up for labor.

For Subcontracted work, 10% mark-up for the first \$5,000; and 5% mark-up for costs in excess of \$5,000.

Subdivision 4.09.4: Tool and Equipment Rental: The rates to be used in determining equipment rental costs shall be as listed in the Caltrans "Labor Surcharge and Equipment Rental Rates" publication in effect at the time of bid.

ARTICLE 4.10 FINAL INSPECTION: The Engineer will not make the final inspection until the work provided and contemplated by the contract has been completed and the final clean-up performed.

ARTICLE 4.11 CONTRACTOR REPORTING REQUIREMENTS: The following items shall be required as a part of Contractor payment requests. Incomplete submittal or omission of any of the following requirements shall be cause for rejection and return of payment requests to the Contractor for correction. All items shall be complete and current to the satisfaction of the Engineer. The Contractor shall provide all information for his own firm as well as each and every subcontractor. Payment requests shall include at least the following items:

- Breakdown of each pay item showing locations and quantities of work requested for payment.
- Certification that the as-built records are current and documented in writing.
- Submission of DBE information including DBE amounts completed to date, DBE providers, Monthly DBE Trucking Utilization Report, and certification that the Contractor is meeting DBE contractual requirements.

- Certified Payroll Reports.
- Updated work schedule.
- All change order requests complete to date, including all Force Account cost supporting documentation.
- Copies of all SWPPP and other Best Management Practices reports, and certification that BMP's are current and implemented.
- Copies of test results (if testing is required of Contractor).
- Survey records, maps, cut sheets, calculations, and other data.
- Subcontractor Change Requests and subcontractor data.
- Other forms or reports as may be required by contract.

ARTICLE 4.12 PENALTIES: Notwithstanding penalty provisions elsewhere in these specifications, the CITY may impose financial penalties in the case of the Contractor not fulfilling his contractual obligations. These obligations include, but are not limited to, performing work within the time limits of the contract; public notification; implementation of Best Management Practices, SWPPP, and other management plans; maintaining records; notification of the Engineer; traffic control; safety; controlling the work area; maintaining a competent supervisor on site at all times while performing work; surveying; testing; updating of schedules; and other such contractual obligations. The Contractor shall be responsible for all obligations and penalties applied to subcontractors as if he himself were performing the work.

The amount of penalty shall be equal to the daily liquidated damages, prorated for each 15 minute period, or portion of 15 minutes, of contract violation. Each violation shall be additive if multiple violations occur during the same time period.

ARTICLE 4.13 CLEANUP, TRAFFIC CONTROL, SAFETY: The Contractor shall maintain complete liability and responsibility for implementing project site cleanliness, traffic control, and safety at all times. If, in the opinion of the Engineer or his designated representative, there is a condition warranting corrective action by the Contractor, the Contractor will be advised and requested to correct the condition to the satisfaction of the Engineer. This requirement in no way absolves the Contractor of any obligation or duty to provide for the safety of persons and property at all times, nor does it impose any obligation or duty on the Engineer to provide any such services or advisement.

The Contractor's supervisor will not leave the project site until he has personally inspected and verified that all cleanliness, traffic control, and safety conditions are in a suitable condition, and has informed the Engineer that he has performed such an inspection. Likewise, no work may commence at the beginning of the work day until all cleanliness, traffic control, and safety measures and procedures have been reviewed, discussed, and implemented by the supervisor with all of the Contractor's and subcontractor's forces.

In the event that the Contractor does not immediately respond to the Engineer's request for corrective action, and the situation presents a hazard to persons and/or property, the Engineer may cause the work to be corrected by others. Likewise, in the event that the Contractor is not on site, cannot immediately respond, or is otherwise unavailable, the Engineer may cause the work to be

corrected by others. If corrective work is performed by others, then the Contractor may be charged for all of the costs, including overhead and indirect costs, required to correct the work. Inspector's costs shall be per Article 4.06 INSPECTION. Engineer's costs shall be 1.5 times the noted Inspector's rate. In addition, the Engineer may impose additional penalties as provided for elsewhere in these specifications.

Full compensation for conforming to the requirements in this article shall be considered as included in the prices bid for the various contract items of work involved and no additional compensation will be allowed therefor.

ARTICLE 4.14 REMOVAL OF PERSONNEL: The Engineer reserves the right to direct the Contractor to remove any specified personnel from the project at any time without reason. If directed, the Contractor shall immediately remove such personnel from the project site, and replace such with another competent person. This requirement shall apply to subcontractor personnel as if they were the Contractor's personnel. Violation shall be subject to penalties as noted elsewhere in these specifications.

SECTION 5. CONTROL OF MATERIAL

ARTICLE 5.01 DRAWINGS AND INFORMATION REQUIRED OF CONTRACTOR: The Contractor shall before proceeding with the fabrication or erection of structures or appurtenances if called for under the contract and required in its erection thereof, furnish the Engineer with the information regarding same and shall submit to the Engineer for approval drawings, specifications, lists and graphs as required under these specifications. Said drawings, specifications, lists and graphs shall become the property of the CITY. In the event that the Engineer shall find that the drawings, specifications, lists and graphs as submitted by the Contractor, are in accordance with acceptable practice and meet the requirements of these specifications, the Engineer will return one (1) set of drawings and lists with his approval within 10 days after their receipt at the Engineer's office; otherwise, said drawings will be returned to the Contractor within the said 10 day period with a statement of the points wherein they have been found unsatisfactory, in which case, the Contractor at his own expense, shall proceed at once to revise said drawings and lists until they shall be found satisfactory by the Engineer and are approved by him. No fabrication shall be done prior to approval of drawings and lists. The Contractor shall have no claim for damages or extension of time on account of any delay due to revision of drawings as found necessary by the Engineer in order to fulfill the requirements of these specifications; but, regardless of such delays, the Contractor shall be liable to the CITY as provided in the specifications for any failure to complete the work as required by the terms of the contract. Revisions shown on shop drawings shall be considered as changes necessary to meet the requirements of specifications and shall not be taken as the basis of claims for extra work.

The approval of all drawings by the Engineer shall apply to general design only and shall in no way relieve the Contractor from responsibility for errors or omissions contained therein; nor shall said approval operate to waive or modify any provisions or requirement contained in these specifications.

ARTICLE 5.02 SAMPLES AND TESTS: All tests of materials furnished by the Contractor shall be made by a laboratory authorized by the Engineer to make the tests and work involved in the contract. The expense of such tests shall be included in the prices bid for the work.

Tests shall be made in accordance with commonly recognized standards of national organizations and such special methods and tests as are described in the Standard Specifications.

No material shall be used until it has been approved by the Engineer. Samples will be secured and tested whenever necessary to determine the quality of materials.

Whenever reference is made in these specifications to standard tests or requirements of the American Society for Testing Materials, the reference shall be construed to mean the standards that are in effect at the date of these specifications.

ARTICLE 5.03 STORAGE OF MATERIALS: Materials shall be so stored as to insure the preservation of their quality and fitness for the work. When considered necessary by the Engineer, they shall be placed on wooden platforms or other hard, clean surfaces and not on the ground. They shall be placed under cover when so directed. Stored materials shall be so located as to facilitate prompt inspection.

ARTICLE 5.04 SUBSTITUTION OF EQUIVALENTS: On demand of the CITY COUNCIL, the Bidder shall, at his own expense, furnish information or data concerning the article, equipment, material or process offered by him as an equivalent to that specified; and, if the CITY COUNCIL shall so require, the Bidder, at his own expense, shall have the article, equipment, materials or process tested to its quality, strength, physical, chemical or other characteristics, its durability, finish, efficiency or service by a reputable testing engineer or laboratory satisfactory to the CITY COUNCIL.

SECTION 6. LEGAL RELATIONS AND RESPONSIBILITIES

ARTICLE 6.01 LAWS TO BE OBSERVED AND DISPUTE RESOLUTION:

Subdivision 6.01.1 Laws and Regulations: The Contractor shall keep himself fully informed of all Federal and State laws, County and CITY ordinances and regulations which, in any manner, affect those engaged or employed on the work, the materials used in the work or the conduct of the work. If any discrepancy or inconsistency should be discovered in this contract or in the Plans or Specifications herein referred to, in relation to any such law, ordinance or regulation, the Contractor shall forthwith report the same in writing to the Engineer. The Contractor shall, at all times, observe and comply with and shall cause all his agents and employees to observe and comply with all such applicable laws, ordinances and regulations in effect or which may become effective before completion of this contract. He shall protect and indemnify the CITY and its officers and agents against any claim or liability arising from or based on the violations of any

such laws, ordinances or regulations whether by himself or by his employees or his subcontractors or their employees.

Except as otherwise explicitly provided in these specifications, all permits and licenses necessary to the prosecution of the work shall be secured by the Contractor at his own expense and he shall pay all taxes properly assessed against his equipment or property used or required in connection with the work.

All state laws, all county and CITY ordinances and regulations now imposed by competent authority and relating to any materials required to be furnished under these specifications and work required to be done hereunder, shall be deemed to be and hereby are made controlling and part of these specifications.

Subdivision 6.01.2 General: The Contractor shall keep himself fully informed of all existing state and national laws and municipal ordinances and regulations which in any manner affect those engaged or employed in the work, or the materials used in the work or which in any way affect the conduct of the work and of all such orders and decrees of bodies or tribunals having any jurisdiction or authority over the same.

Subdivision 6.01.3 Eight-Hour Law: Eight (8) hours labor constitutes a legal day's work. The Contractor shall forfeit as a penalty twenty-five dollars (\$25.00) for each workman employed in the execution of the contract by the Contractor or any subcontractor under him for each calendar day during which such workman is required or permitted to work more than eight (8) hours in any one calendar day and forty (40) hours in any one calendar week in violation of the provisions of the Labor Code and in particular, Section 1810 to Section 1815 thereof inclusive except that work performed by employees of Contractors in excess of eight (8) hours per day and forty (40) hours during any one week, shall be compensated at not less than one and one-half (1 ½) times the basic rate of pay as provided in Section 1815.

Subdivision 6.01.4 Prevailing Rate of Per Diem Wages: Pursuant to the provisions of Section 1773 of the Labor Code of the State of California, the Director of Industrial Relations has ascertained the general prevailing rate of wages and employer payments for health and welfare, vacation, pension and similar purposes applicable to the work to be done.

The Contractor shall comply with Labor Code Section 1775. In accordance with said section, the Contractor shall forfeit as a penalty to the CITY fifty dollars (\$50.00) for each calendar day, or portion thereof, for each workman paid less than the stipulated prevailing rates for such work or craft in which such workman is employed for any work done under the contract by him or by any subcontractor under him in violation of the provisions of the Labor Code and in particular Labor Code Sections 1770 to 1780, inclusive. In addition to said penalty and pursuant to said Section 1775, the difference between such stipulated prevailing wage rates and the amount paid to each workman for each calendar day or portion thereof for which each workman was paid less than the stipulated prevailing wage rate shall be paid to each workman by the Contractor.

Subdivision 6.01.5 Certified Payroll: Pursuant to Section 1776 of the Labor Code, the Contractor and/or subcontractors shall submit weekly to the CITY for each week in which any

contract work is performed a certified copy of all payroll records. Should the Contractor fail to provide such payroll certificates, the CITY may withhold one thousand dollars (\$1,000) for each weekly payroll certificate not received from payment due.

Subdivision 6.01.6 Governing Law, Venue, Dispute Resolution and Attorneys' Fees: This Agreement will be governed by and construed in accordance with laws of the State of California. Specifically, Government Code Section 9204 (A summary of which is set forth in Subdivision 6.01.7). If any disputed portion of the claim is not resolved with the procedure set forth in Subdivision 6.01.7 herein, prior to commencing suit in a court of competent jurisdiction, any unresolved portion of any controversy, dispute or claim arising out of the Agreement will first be submitted to an alternative dispute resolution process as set forth in Subdivision 6.01.8 herein. Any action at law or in equity brought by either of the parties hereto for the purpose of enforcing a right or rights provided for by this Agreement will be tried in a court of competent jurisdiction in the County of Orange, State of California. In the event either party hereto will bring suit to enforce any term of this Agreement or to recover any damages for and on account of the breach of any term or condition of this Agreement, it is mutually agreed that the prevailing party in such action will recover all costs thereof, including reasonable attorneys' fees, to be set by the court in such action.

Subdivision 6.01.7 Summary of Government Code Section 9204: A “claim” is a separate demand on the CITY by a Contractor on a public works project and sent by registered mail or certified mail with return receipt requested, for one or more of the following:

- A time extension, including relief from penalties for delay;
- Payment by the CITY of money damages under the terms of the contract;
- Payment of an amount that is disputed by the CITY.

Initial Review. The claim must be supported by appropriate documentation. The CITY has forty-five (45) days within which to review the claim and provide the Contractor with a written statement identifying the disputed and undisputed portions of the claim. If the CITY does not issue a written statement, the claim is deemed rejected in its entirety. The CITY will pay any undisputed portion of the claim within sixty (60) days of issuing the statement.

Meet & Confer. If the Contractor disputes the CITY’s written response, or if the CITY does not issue one, the Contractor may request in writing an informal conference to meet and confer for possible settlement of the claim. The CITY will schedule the meet and confer conference within thirty (30) days of this request and provide a written statement identifying the remaining disputed and undisputed portions of the claim within ten (10) business days of the meet and confer. The CITY will pay the undisputed portion within sixty (60) days of issuing this statement.

Mediation. With respect to any disputed portion remaining after the meet and confer, the CITY and Contractor must submit the matter to nonbinding mediation, agree to a mediator within ten (10) business days after issuing the written statement, and share mediation costs equally. If mediation is unsuccessful, then the terms of the public works agreement and applicable law will govern resolution of the dispute.

Miscellaneous Provisions. Amounts not paid by the CITY in a timely manner bear interest at 7% per annum. Subcontractors may submit claims via this procedure through the general contractor. The CITY and Contractor may waive the requirement to mediate, but cannot otherwise waive these claim procedures.

Subdivision 6.01.8 Alternative Dispute Resolution: In the event that there is any controversy, dispute or claim arising out of or relating to this Agreement, which have not been resolved pursuant to the process summarized in Subdivision 6.01.7 herein, the parties hereto will consult and negotiate with each other and, recognizing their mutual interest, attempt to reach a solution satisfactory to both parties. If they do not reach settlement within a period of sixty (60) days, the matter will be submitted to nonbinding arbitration (“Process”) by written notice from either party to the other. The parties will meet and confer in good faith and select an arbitrator that is agreeable to both sides. The Process will be completed no later than one hundred twenty (120) days (“Process Period”) after tender of the aforementioned written notice, unless the Parties mutually agree to an extension of the Process Period. If the matter is not successfully resolved by the Process, within the Process Period, the parties are free to commence litigation in a court of competent jurisdiction as defined in Subdivision 6.01.6 herein. Any litigation commenced without both parties’ consent prior to the end of the Process Period, will be subject to a stay until the end of the Process Period. The Parties further agree to equally bear the cost of the Process.

ARTICLE 6.02 PERMITS AND LICENSES: The Contractor shall procure all permits and licenses, pay all charges and fees, and give all notice necessary and incident to the due and lawful prosecution of the work. No fee is charged for an Encroachment Permit issued by the CITY for a Public Works Project. The Contractor and his subcontractors shall obtain a CITY Business License.

Full compensation for conforming to the requirements in this article shall be considered as included in the price bid for the various contract items of work involved and no additional compensation will be allowed therefor.

ARTICLE 6.03 PATENTS: The Contractor shall assume all costs arising from use of patented materials, equipment, devices or processes used on or incorporated in the work and agrees to indemnify and save harmless the CITY, the CITY COUNCIL, the City Engineer and their fully authorized representatives from all suits of law or actions of every nature for, or on account of, the use of any patented materials, equipment, devices or processes.

ARTICLE 6.04 PRESERVATION OF PROPERTY: The Contractor shall conduct the operations in a careful and prudent manner to avoid damage to adjacent property.

The Contractor shall preserve and protect all on-site and roadside trees from injury. All trees useful for shade or other purposes shall be cared for by the Contractor and no trees within the limits of project site shall be cut or removed unless indicated on the plans.

All fences along the line of the improvement shall be protected by the Contractor; if they are injured or destroyed they shall be restored to a condition as good as when he entered upon the

work. It is required that the Contractor replace in kind or reimburse the owners thereof for all fences, shrubs, buildings and other improvements damaged or removed by the construction operations not shown on the plans.

The Contractor shall preserve and protect from damage to all buildings, pole lines, pipe lines and all direction, warning and mileage signs and any other structures which have been placed within the limits of the project site.

Full compensation for conforming to the requirements in this article shall be considered as included in the price bid for the various contract items of work involved and no additional compensation will be allowed therefor.

ARTICLE 6.05 PRESERVATION OF MONUMENTS: The Contractor shall not disturb any monuments, stakes or sign posts found on the line of the improvement until authorized by the Engineer. The Contractor shall bear the expense of resetting any monument, stakes or sign posts which may be disturbed without authorization from the Engineer. After construction and prior to final acceptance, the Contractor's land surveyor or qualified Civil Engineer shall re-survey all field monuments and centerline ties within the construction zone, prepare tie sheets and Corner Record sheets, and file them with the City Engineer for review. After review by the City Engineer, the land surveyor shall file the Corner Records with the Orange County Land Surveyors Office as required by law, and file certified copies of the Corner Records with the City Engineer. Project retention will not be released until all records are recorded with the County Land Surveyor Office.

ARTICLE 6.06 RESPONSIBILITY FOR DAMAGE: During the progress of the work, the CITY will not be answerable or accountable, in any manner, for any loss or damage that may happen to the work or any part thereof; or for injury to any person or persons, either workmen or the public, or for damage to adjoining property from any cause which might have been prevented by the Contractor or his workmen or any one employed by him, against all of which injuries or damages to persons and property the Contractor having control over such work must properly guard. The Contractor shall be responsible for any damage to any person or property resulting from defects or obstructions or from any causes whatsoever during the progress of the work, or at any time before its completion and final acceptance and shall indemnify and save harmless the CITY and/or its officers and/or its employees from all suits or actions of every name and description brought for or on account of any injuries or damages received or sustained by any person or persons by or from the Contractor, his servants or agents in the construction of the work or by or in consequence of any negligence in guarding the same in improper materials used in its construction or by or on account of any act or omission of the Contractor or his agents.

ARTICLE 6.07 COOPERATION BETWEEN CONTRACTORS: Where two or more contractors are employed on related or adjacent work, each shall conduct his operations in such a manner as not to cause any unnecessary delay or hindrance to the other. Each

contractor shall be responsible to the other for all damage to work, person or property or for loss caused by failure to finish the work within the time specified for completion.

ARTICLE 6.08 CONTRACTOR'S RESPONSIBILITY FOR WORK: Except as provided above, until the formal acceptance of the work by the CITY COUNCIL, the Contractor shall have the charge and care thereof and shall bear the risk of injury or damage to any part thereof by the action of the elements or from any other cause whether arising from the execution or from the non-execution of the work. The Contractor shall rebuild, repair, restore and make good all injuries or damages to any portion of the work occasioned by any of the above causes before its completion and acceptance and shall bear the expense thereof except for such injuries or damages as occasioned by acts of the Federal Government and the public enemy. In case of suspension of work from any cause whatever, the Contractor shall be responsible for all materials and shall properly store them, if necessary, and shall provide suitable drainage of the project site and erect temporary structures where necessary.

ARTICLE 6.09 NO PERSONAL LIABILITY: Before the contract is executed on behalf of the CITY, a bidder to whom the contract has been awarded shall furnish to the CITY a policy or certificate of protective liability insurance in which the CITY shall be named as an additional insured with the bidder. The policy shall insure the CITY, his officers, and his employees; the bidder, his employees and his subcontractors and their employees, their heirs, agents and employees; while acting within the scope of their duties against all claims arising out of or in connection with the work to be performed and shall remain in full force and effect until the work is accepted by the CITY. The policy shall provide for the following limits:

Minimum Scope of Insurance.

- A. Workers Compensation & Employers Liability Insurance
 - Workers Compensation insurance with statutory limits as required by the Labor Code of the State of California.
 - Employers Liability with limits of \$1,000,000 per Accident; \$1,000,000 Disease per employee; \$1,000,000 Disease per policy.
 - The policy shall include a written waiver of the insurer's right to subrogate against CITY.
 - Required Evidence Of Coverage:
 - 1. Subrogation waiver endorsement; and
 - 2. Properly completed Certificate of Insurance.

- B. General Liability Insurance
 - Commercial General Liability Insurance no less broad than Insurance Services Office (ISO) form CG 00 01.
 - Coverage shall be on a standard occurrence form. Claims-Made forms are not acceptable without prior written consent. Modified, limited or restricted Occurrence forms are not acceptable without prior written consent.

- Minimum Limits: \$2,000,000 per Occurrence; \$4,000,000 General Aggregate; \$4,000,000 Products/Completed Operations Aggregate. The General Aggregate shall apply separately to each project. The required limits may be provided by a combination of General Liability Insurance and Commercial Excess or Umbrella Liability Insurance. If contractor maintains higher limits than the specified minimum limits, CITY requires and shall be entitled to coverage for the higher limits maintained by contractor.
- Any deductible or self-insured retention shall be shown on the Certificate of Insurance. If the deductible or self-insured retention exceeds \$25,000 it must be approved in advance by CITY. Contractor is responsible for any deductible or self-insured retention and shall fund it upon CITY'S written request, regardless of whether Contractor has a claim against the insurance or is named as a party in any action involving CITY.
- Coverage shall be continued for one (1) year after completion of the work.
- CITY shall be endorsed as an additional insured for liability arising out of ongoing and completed operations by or on behalf of the contractor. CITY shall continue to be an additional insured for completed operations for (1) year after completion of the work.
- The policy definition of "insured contract" shall include assumptions of liability arising out of both ongoing operations and the products-completed operations hazard ("F" definition of insured contract in ISO form CG 00 01, or equivalent).
- The insurance provided to the additional insureds shall be primary to, and non-contributory with, any insurance or self-insurance program maintained by them.
- The policy shall cover inter-insured suits and include a "Separation of Insureds" or "severability" clause which treats each insured separately.
- The policy shall be endorsed to include a written waiver of the insurer's right to subrogate against all persons or entities that are, or are required to be, additional insureds.
- The policy shall not contain a Contractors' Warranty or other similar language which eliminates or restricts insurance because of a subcontractor's failure to carry specific insurance or to supply evidence of such insurance.
- Required Evidence of Coverage:
 1. Copy of the additional insured endorsement or policy language granting additional insured status;
 2. Copy of the endorsement or policy language indicating that coverage applicable to the additional insureds is primary and non-contributory;
 3. Properly completed Certificate of Insurance; and
 4. Completed and signed Agent/Broker Questionnaire with supporting documentation as required.
 5. City of Whittier shall also be listed as additionally insured.

C. Automobile Liability Insurance

- Minimum Limit: \$2,000,000 combined single limit per accident.
- Coverage shall apply to all owned, hired and non-owned vehicles.
- CITY shall qualify as an insured.
- Required Evidence of Coverage:

1. Copy of the endorsement or policy language indicating that CITY is an insured; and
2. Properly completed Certificate of Insurance.
3. City of Whittier shall also be listed as additionally insured.

D. Standards for Insurance Companies

- Insurers, other than the California State Compensation Insurance Fund, shall have an A.M. Best's rating of at least A:VII.

E. Documentation

- The Certificate of Insurance shall include the following reference: [Macy Street Rehabilitation Project. City of La Habra Project 1-R-23]
- The name and address for Additional Insured endorsements and Certificates of Insurance is: City of La Habra and City of Whittier
- Contractor shall provide immediate written notice if: (1) any of the required insurance policies is terminated; (2) the limits of any of the required policies are reduced; or (3) the deductible or self-insured retention is increased.
- Current Evidence of Coverage shall be provided for the entire required period of insurance.
- Upon written request, certified copies of required insurance policies shall be provided within thirty (30) days.

F. Insurance for Caltrans and City of Whittier

- Contractor shall supply sufficient insurance as set forth by Caltrans and the City of Whittier at no additional cost to the City of La Habra

All insurance issued in compliance with this section shall be insured in the form and by the insurer or insurers satisfactory to and first approved by the CITY in writing. The Contractor shall not allow any subcontractor to commence work on his subcontract until the subcontractor has secured all required bonds and insurance.

ARTICLE 6.10 WORKER'S COMPENSATION INSURANCE: The Contractor shall procure and maintain Worker's Compensation Insurance as required by applicable state or territorial law for all of his employees to be engaged in work at the site of the project under this Contract. In case of any such work sublet, the Contractor shall require the subcontractor similarly to provide Worker's Compensation Insurance for all of the latter's employees to be engaged in such work unless such employees are covered by the protection afforded by the Contractor's Worker's Compensation Insurance. In case any class of employees engaged in hazardous work on the project under this Contract is not protected under the Worker's Compensation Statute, the Contractor shall provide and shall cause each subcontractor to provide adequate employer's liability insurance for the protection of such of his employees as are not otherwise protected.

The Contractor and/or subcontractor shall file a copy of their Certificate of Compensation Insurance with the CITY and no work shall begin until such certificate is filed with the CITY. In the event of cancellation, the insurance company shall give the CITY ten (10) days written notice.

ARTICLE 6.11 SUBCONTRACTING: Attention is directed to the provisions in Section 1-6.2, "Subcontractor Listing", of the Standard Specifications and these Special Provisions.

In accordance with the requirements of Sections 4100 to 4133 inclusive of the Public Contract Code, each bidder shall list in his Proposal the name and business address of each subcontractor to whom the bidder proposes to subcontract all or a portion of work and shall list each subcontractor licensed by the State of California proposed by the bidder to specially fabricate and install all or a portion of the work. Said list shall include a description of the portion of the work which will be done by each subcontractor.

A sheet for listing the subcontractors as required is included in the proposal. The successful responsible bidder shall submit a letter to the CITY requesting approval of all subcontractors. Included in the letter shall be a list of the names and addresses of each Contractor, items to be subcontracted by item number, brief description of the item, and contract bid value. If only a portion of the item is to be subcontracted, that portion and dollar value of work, based on contract item bid value, shall be indicated.

No subcontractor shall be permitted to perform any work under the contract without having first been approved, in writing, by the CITY.

ARTICLE 6.12 TRESPASS: The Contractor shall be responsible for all damage or injury which may be caused on any property by trespass of the Contractor's employees in the course of their employment whether the said trespass was committed with or without the consent or knowledge of the Contractor.

ARTICLE 6.13 SAFETY, SANITARY AND MEDICAL REQUIREMENTS: The Contractor, his employees, his subcontractors and their employees shall promptly and fully carry out the existing safety, sanitary and medical requirements as may from time to time be prescribed by the Industrial Safety Commission and by County or State Health Departments to the end that proper work shall be done and the safety and health of the employees and of the community may be conserved and safeguarded. In case any such regulations and orders are not observed by the Contractor, they may be enforced by the Engineer at the Contractor's expense.

ARTICLE 6.14 WATER AND POWER: Unless otherwise provided in the Special Provisions, the Contractor shall provide, at his own expense, all necessary water and power required for his operations under the contract.

ARTICLE 6.15 PROTECTION OF UNDERGROUND FACILITIES: Attention is directed to the possible existence of underground facilities not known to the CITY or in a location different from that which is indicated on the plans or in these Special Provisions. The Contractor shall take steps to ascertain the exact location of all underground facilities prior to doing work that may damage such facilities or interfere with their service. If the Contractor discovers underground facilities not indicated on the

Plans or in these Special Provisions, he shall immediately give the Engineer written notification of the existence of such facilities. Such facilities shall be protected from damage as directed by the Engineer and the Contractor will be paid for such work as extra work as provided in Section 7-4 "Payment for Extra Work" of the Standard Specifications.

ARTICLE 6.16 AIR POLLUTION CONTROL: Section 3-12.2, "Air Pollution Control", of the Standard Specifications is supplemented by the following:

The Contractor shall comply with all air pollution control rules, regulations, ordinances and statutes which apply to any work performed pursuant to the contract including any air pollution control rules, regulations, ordinances and statutes specified in Section 11017 of the Government Code.

In the absence of any applicable air pollution control rules, regulations, ordinances or statutes governing solvents, all solvents, including but not limited to the solvent portions of paints, thinners, curing compounds, and liquid asphalt used on the project shall comply with the applicable material requirements of the County Air Pollution Control District. All containers of paint, thinner, curing compound or liquid asphalt shall be labeled to indicate that the contents fully comply with said requirements.

Full compensation for conforming to the requirements in this article shall be considered as included in the price bid for the various contract items of work involved and no additional compensation will be allowed therefor.

ARTICLE 6.17 PROJECT APPEARANCE: The Contractor shall maintain a neat appearance to the work. In any area visible to the public, the following shall apply:

When practicable, broken concrete and debris developed shall be disposed of concurrently with its removal. If stockpiling is necessary the material shall be removed or disposed of on the next working day, except that stockpiles shall not be left in the public right of way on weekends or holidays.

Full compensation for conforming to the requirements in this article shall be considered as included in the prices bid for the various contract items of work involved and no additional compensation will be allowed therefor.

ARTICLE 6.18 FAIR EMPLOYMENT PRACTICE COMMISSION CERTIFICATION: The Contractor's attention is directed to the requirements in Section 12990 of the Government Code for nondiscrimination and compliance employment programs.

ARTICLE 6.19 SOUND CONTROL REQUIREMENTS: The Contractor shall comply with all local sound control and noise level rules, regulations and ordinances which apply to any work performed pursuant to the Contract.

Each internal combustion engine used for any purpose on the job or related to the job shall be equipped with a muffler of a type recommended by the manufacturer. No internal combustion engine shall be operated on the project without said muffler.

The noise level from the Contractor's operations between the hours of 7:00 a.m. and 4:00 p.m. shall not exceed 86 DBA at a distance of 50 feet. This requirement in no way relieves the Contractor from responsibility for complying with local ordinances regulating noise level.

Said noise level requirement shall apply to all equipment on the job or related to the job including, but not limited to, trucks, transit mixers or transient equipment that may or may not be owned by the Contractor. The use of loud sound signals shall be avoided in favor of light warnings except those required by safety laws for the protection of personnel.

Full compensation for conforming to the requirements in this article shall be considered as included in the prices bid for the various contract items of work involved and no additional compensation will be allowed therefor.

ARTICLE 6.20 LEGAL RELATIONS AND RESPONSIBILITY: The Contractor's attention is directed to the provisions of Section 5, "Legal Relations and Responsibilities", of the Standard Specifications and these Special Provisions for the requirements and conditions which he must observe in the execution of the work.

SECTION 7. PROSECUTION AND PROGRESS

ARTICLE 7.01 PROSECUTION AND PROGRESS: The Contractor's attention is directed to Section 6, "Prosecution and Progress of the Work", of the Standard Specifications.

ARTICLE 7.02 TIME LIMIT: The work specified herein and shown on the Plans and Specifications shall be completed within **Thirty (30) working days** from the start date specified in the Notice to Proceed. Attention is directed to Section 3-13 and 6-9 of the Standard Specifications for Public Works Construction (The "Greenbook"), "Completion, Acceptance, and Warranty"; and "Liquidated Damages". The CITY shall withhold liquidated damages before the accrual date if the anticipated liquidated damages may exceed the value of the remaining work. Liquidated damages for all work except plant establishment are as shown in the following table:

If the total amount of working days have expired and the work is not complete, liquidated damages are five hundred dollars (**\$500.00**) per calendar day.

SECTION 8. PAYMENTS

Within fifteen (15) workdays after the date of acceptance of the work the Engineer will cause to be filed on behalf of the CITY in the Office of the County Recorder a Notice of Completion of the work herein agreed to be done by the Contractor.

Upon expiration of forty-five (45) days after the filing of such Notice of Completion of the work, the CITY will pay to the Contractor the amount remaining after deduction from the amount of value stated in the above-mentioned estimate all prior payments to the contract and all amounts to be kept and retained under the provisions of the Contract.

If the Contractor disagrees with the Engineer's final estimate and within said period of forty-five (45) days files a written statement of his claims, the Engineer will issue as a semi-final estimate the proposed estimate submitted to the Contractor and the CITY will within thirty (30) days pay the sum found due thereon after deducting from the amount of value stated in the first mentioned estimate all prior payments to the Contractor and all amounts to be kept and retained under the provisions of the contract. The Engineer will then consider and investigate the Contractor's claim and will make such revision in the said estimate as he may find to be due and will then certify in writing to the City Clerk the whole amount and value of the work done by the Contractor under and according to the terms of the contract. The CITY will pay the amount so found due after deducting all previous payments, amounts to be retained under the contract, and amounts which may be retained in accordance with the applicable specifications.

ARTICLE 8.01 PARTIAL PAYMENTS: At the request of the Contractor, partial payments will be made on a monthly basis. The Progress Pay requests shall be submitted on or before the 20th day of each month. The estimate may include only work completed up to and including this date.

Progress pay requests showing work not accomplished by the 20th day of the month shall be rejected.

ARTICLE 8.02 PAY RETENTION: From each progress estimate **five percent (5%)** will be deducted and retained in accordance with Section 7-3.2 of the Standard Specifications.

ARTICLE 8.03 FINAL ESTIMATE AND PAYMENT: Whenever in the opinion of the Engineer the Contractor shall have completely performed the contract on his part the Contractor shall submit to the Engineer a written statement to the final quantities of contract items for inclusion in the final estimate.

All prior estimates upon which partial payments have been made shall be subject to correction in the final estimate. The final estimate and payments made thereunder shall be final and conclusive upon the Contractor.

ARTICLE 8.04 TAXES: No mention shall be made of sales tax or use tax, as all bid prices submitted shall be considered as including such tax.

SECTION 9. WORK SCHEDULES

ARTICLE 9.01 WORK SCHEDULE: Before the commencement of work, the Contractor shall submit a work schedule prepared using the latest version of Microsoft Project or approved equal to the Engineer for approval. The work schedule shall be submitted at least five (5) days prior to commencement of work or at the Pre-Construction Meeting, and shall be kept current through the progress of the work. The work shall be performed in order of their priorities and as directed by the Engineer.

The Contractor shall schedule his work so that all excavated locations shall be poured concrete no later than Friday. The Contractor shall not excavate any location that he is not sure that he is able to pour on Friday. No excavated location is allowed over weekends and / or holidays. The Contractor shall pay the sum of eight hundred dollars (**\$800.00**) per each calendar day for each excavation left open and not poured concrete over the weekend starting on Saturday or over a holiday for the sidewalk portion of the work.

Full compensation for conforming to the requirements in this article shall be considered as included in the prices bid for the various contract items of work involved and no additional compensation will be allowed therefor.

SECTION 10. CITY REQUIREMENTS

ARTICLE 10.01 FAIR EMPLOYMENT PRACTICES: In connection with the performance of work under this Contract, the Contractor agrees as follows:

1. The Contractor will not willfully discriminate against any employee or applicant for employment because of race, sex, color, religion, age, handicap status, or national origin. The Contractor will take affirmative action to ensure that the applicants are employed, and that employees are treated during employment, without regard to their race, sex, color, religion, age, handicap status, or national origin. Such action shall include, but not be limited to, the following: employment upgrading, demotion or transfer; recruitment or recruitment advertising; layoff or termination; rates of pay or other forms of compensation; and selection for training, including apprenticeship. The Contractor agrees to post in conspicuous places, available to employees and applicants for employment, notices to be provided by awarding authority setting forth the provisions of this fair Employment Practices section.
2. The Contractor will send to each labor union or representative of workers with which he has collective bargaining agreement or other contract or understanding, a notice advising the said labor union workers' representative of the Contractor's commitments under this section, and shall post copies of the notice in conspicuous places available to employees and applications for employment.
3. The Contractor will permit access to his records of employment, employment advertisements, application forms, and other pertinent data and records the Fair Employment Practices Commission, the CITY or any other appropriate agency designated by the CITY for the purposes of investigation to ascertain compliance with the Fair Employment Practices section of this Contract.

4. The finding of willful violation of the Fair Employment practices section of this Contract or of the Fair Employment Practices Act shall be regarded by the CITY as a basis for determining the Contractor to be not a “responsible bidder” as to future contracts for which such Contractor may submit bids.

The CITY shall deem a finding of willful violation of the Fair Employment Practices Act to have occurred upon receipt of written notice from the Fair Employment Practices Commission that it has investigated and determined that the Contractor has violated the Fair Employment Practices Act and has issued an order under Government Code Section 12970 or obtained an injunction under the Government Code Section 12973.

Upon receipt of such written notice from the Fair Employment Practices Commission, the CITY shall notify the Contractor that unless he demonstrates to the satisfaction of the awarding authority within a stated period that the violation has been corrected, his prequalification rating will be revoked at the expiration of such period.

5. The Contractor agrees, that should the CITY determine that the Contractor has not complied with the Fair Employment Practices section of this Contract, then pursuant to Labor Code Section 1735 and 1755, the Contractor shall, as a penalty to the Agency, forfeit for each calendar day, or portions thereof, for each person who was denied employment as a result of such non-compliance, the penalties provided in the Labor Code for violation of prevailing wage rates. Such monies may be recovered from the Contractor. The Agency may deduct any such damages from any monies due to the Contractor from the Contract.
6.
 - a. Nothing contained in this Fair Employment Practices section shall be construed in any manner or fashion so as to prevent the CITY from pursuing any other remedies that may be available by law.
 - b. Nothing contained in this Fair Employment Practices section shall be construed in any manner or fashion so as to require or permit the hiring of an employee not permitted by the National Labor Relations Act.
7. Prior to award of the Contract, the Contractor shall certify to the awarding authority that he has or will meet the following standards for affirmative compliance which shall be evaluated in each case by the CITY.
 - a. The Contractor shall provide evidence, as required by the CITY, that he has notified all supervisors, foremen and other personnel officers in writing of the content of the anti-discrimination clause and their responsibilities under it.
 - b. The Contractor shall provide evidence, as required by the CITY, that he has notified all sources of employee referrals (including unions, employment agencies, advertisements, Department of Employment) of the content of the anti-discrimination clause.

- c. Personally, or through his representatives, the Contractor shall, through negotiations with the unions with whom he has agreements, attempt to develop an agreement which will:
 - (1) Spell out responsibilities for non-discrimination in hiring, referral, upgrading and training.
 - (2) Otherwise implement an affirmative anti-discrimination program in terms of the union's specific areas of skill and geography, to the end that qualified minority workers will be available and given an equal opportunity for employment.
 - d. The Contractor shall notify the CITY of opposition to the anti-discrimination clause by individuals, firms or organizations during the period of its prequalification.
8. The Contractor will include the provisions of the foregoing paragraphs 1 through 7 in every first tier subcontract, so that such provisions will be binding upon each such subcontractor.
 9. The Contractor, in executing the proposal, thereby certifies that he has or will meet the standards for affirmative compliance with the Fair Employment Practices requirements contained herein.
 10. The Contractor shall comply with the procedures and conditions set forth in Section XII of the City of La Habra Affirmative Action Plan as adopted by Resolution 2404 of the City of La Habra January 21, 1975, a portion of which reads as follows:

“It shall be the policy of the City of La Habra to require all contractors and vendors doing business with the CITY in an amount in excess of \$50,000.00 and/or 200 employees to certify their compliance with Title VII of the civil Rights Act and the Equal Employment Opportunity Act of 1972. Said certification shall be stipulated by the CITY to safeguard against discrimination by contractors or vendors on the basis of race, color, creed, sex, age, or nationality concerning the practices of recruitment, promotion, demotion, transfer, layoff, or termination. A violation of this non-discrimination certification will be considered a material provision violation and shall be grounds for termination or suspension, in whole or in part, of the contract by the CITY”.

SECTION 11. CONSTRUCTION DETAILS

ARTICLE 11.01 GENERAL:

Subdivision 11.01.1 Description of Work: The general items of work to be performed hereunder shall be in various locations throughout the CITY, comprises the furnishing of

all materials, equipment, tools, labor and incidentals and shall consist of but not be limited to

Mobilization/Demobilization; Traffic Control, Safety and Cleanup; Construction Staking and Monument Perpetuation; Storm Water Best Management Practices (BMPs); Crack Sealing; Unclassified Excavation and Disposal, Construct Rubberized AC pavement Overlay, Cold mill and Dispose of Existing Asphalt; Remove and Dispose of Existing Asphalt; Sawcut, Remove, and Construct Concrete Sidewalk; Sawcut, Remove, and Construct Concrete Curb and Gutter and Driveways over CMB with AC Slot Trench; Sawcut and Remove Sidewalk and Ramp and Construct Curb Ramp with Detectable Warning Surface; Traffic Striping, Crosswalks, Curb Painting, Markings, and Raised Pavement Markers; Traffic Signal Loop Detectors; Adjust to Grade Water Valves, Manhole Covers; Traffic Signal Pull boxes, and Water Meter Boxes; Coordinate with Utilities for Adjust to Grade by Others; Grind Tree Roots; and all incidental work so indicated on the specifications, and required for the proposed improvements.

Subdivision 11.01.2 Order of Work: Order of work shall conform to the provisions of Section 6-1, "Construction Schedule and Commencement of the Work," of the Standard Specifications for Public Works Construction (The "Greenbook") and these Special Provisions.

The Contractor shall determine the sequence of work necessary to diligently pursue completion of the work, in accordance with the Special Provisions. Work shall be phased and constructed so that at the end of each work day, excavated trenches will be covered flush to grade by steel plates or pavement, opened to traffic, and parking restored. For cold milling, the Contractor shall mill only the quantity of street that the Contractor can base pave the same working day. Open trenches adjacent to sidewalks shall be covered and protected for pedestrian traffic. No open parkway excavation will be allowed over weekends. Sidewalks shall be ramped or filled to grade during the week.

- 1. Procurement of all materials requiring long lead-time. The Contractor shall order all long lead-time supplies, materials and equipment within ten (10) working days after the award of contract by the CITY.**
- 2. Develop and set up traffic control measures.**
- 3. Install initial project storm water pollution prevention plan and BMPs.**
- 4. Complete all required excavation. All Local Dig outs shall be completed before full street width milling operation begins.**
- 5. Complete all concrete improvements.**
- 6. Complete all backfill, compaction, T-cuts, AC cap and pavement restoration.**
- 7. Complete all street improvements.**
- 8. Adjust surface utilities and manholes to grade.**
- 9. Complete signing, striping, pavement markings and traffic loops.**

Subdivision 11.01.3 Public Convenience and Access: The Contractor shall conduct his operations so as to cause minimum obstruction and inconvenience to the public.

At least five (5) days prior to commencing work, the Contractor shall submit to the Engineer his construction schedule for approval in accordance with Section 9. This schedule shall allow businesses and residents on the affected streets to park within a reasonable distance from their business or home. The Contractor shall distribute to each resident or business affected by the construction a written notice at least 5 days prior to commencing construction. The notice shall include the date and working hours of construction. It shall be the Contractor's responsibility to complete the notification letter with the proper dates at the time of notification. If the Contractor fails to meet the schedule indicated in the Notice, the Contractor shall reschedule his work and re-notify the residents.

Continuous emergency and local traffic access shall be maintained in the area of work and vehicular access to individual driveways shall be provided and maintained except for short durations of not more than two hours and with prior notice to the adjacent residents involved. No overnight closure of driveways will be allowed except while construction is in progress and concrete is curing. The Contractor shall provide alternate ramps for access while concrete is curing, where feasible.

Should the Contractor appear to be neglectful or negligent in furnishing warning and protective measures, the Engineer may direct the Contractor's attention to the existence of such hazards. The Contractor shall provide all necessary warning and protective measures immediately, at his expense. Whether the Engineer points out the inadequacy of warning and protective measures or not, such action, or lack of action, on the part of the Engineer shall not relieve the Contractor from the responsibility for public safety or abrogate his obligation to furnish and pay for safety measures and devices. If attention is directed to the existence of a hazard, and the Contractor fails to provide an appropriate remedy, any expense incurred by the CITY for furnishing or maintaining safety measures and devices may be deducted from the pay estimates and the total contract price for the work.

The Contractor shall maintain access for residents at all times during the construction and at the end of each work day as specified above. The travel lanes shall be graded smooth and shall be maintained in a smooth condition throughout the period of construction including weekends, and at times as directed by the Engineer.

The Contractor shall be responsible for maintaining location of, and access to, all utilities and underground facilities during construction operations, including but not limited to valves and monitoring wells.

Subdivision 11.01.4 Public Notice: The Contractor shall notify businesses and residents affected by the construction in writing not less than 5 days advance of commencement of demolition, construction, or storage of materials in the street. The notice shall include but not be limited to:

1. Time and Date of Commencement.
2. Working Hours of Construction.
3. Date of Completion.
4. Name & Telephone Number of Person to be Contacted, at any hour, in the event of a condition requiring immediate correction.

A copy of the letter shall be submitted to the City Engineer for approval prior to distribution.

The Contractor shall also notify La Habra Police Department, Los Angeles County Fire Department, Trash Hauler, Post Office, Ambulance Service, La Habra City School District, and Orange County Transportation Authority about the construction. It shall be the Contractor's responsibility to complete the notification letter, with the proper dates, at the time of notification. If the Contractor fails to meet the schedule indicated in the Notice, the Contractor shall reschedule his work and re-notify all those listed above.

Subdivision 11.01.5 Hours of Work: All work shall be performed between 7:00 A.M. and 4:00 P.M., Mondays through Fridays except holidays. No work shall be performed outside normal working hours without advanced authorization from the Engineer. If work is adjacent to a school or on a major arterial, working hours will be restricted to 9:00 A.M. and 3:00 P.M. for lane closures, Mondays through Fridays except holidays. For any inspection outside of regular working hours, the Contractor shall pay all costs for the inspector's time. Request for overtime inspection shall be made in writing to the Engineer.

Full compensation for conforming to the requirements in this article shall be considered as included in the prices bid for the various contract items of work involved and no additional compensation will be allowed therefor.

ARTICLE 11.02 FURNISH AND APPLY WATER: Should the Contractor require water for construction operations, such as for compaction and dust control, he may use water from any fire hydrant adjacent to the job site upon application of a "No Fee" permit from the CITY, Engineering Department. The Contractor shall apply water for dust control as necessary and as directed by the Engineer.

Prior to using water, the Contractor shall install a water meter, a valve and an approved back-flow prevention device on the fire hydrant at his expense. The Contractor shall notify Los Angeles County Fire Department and the Public Works Department twenty-four (24) hours in advance, stating the location of the hydrant and the hours when it will be used. The Contractor shall operate the fire hydrant with a hydrant wrench only. Should damage occur to the hydrant, the Contractor shall make repairs at his expense and/or further use of CITY Water may be prohibited. The meter will be used for monitoring water use only. The Contractor will not be charged for water used on the project.

Full compensation for conforming to the requirements in this article shall be considered as included in the prices bid for the various contract items of work involved and no additional compensation will be allowed therefor.

ARTICLE 11.03 DUST CONTROL: The Contractor shall at all times, including weekends, at his expense, control dust on the project. Should the Contractor fail to maintain adequate dust control, the CITY will maintain the site, and an amount equal to twice the actual cost shall be assessed to the Contractor.

Full compensation for conforming to the requirements in this article shall be considered as included in the prices bid for the various contract items of work involved and no additional compensation will be allowed therefor.

ARTICLE 11.04 EXCESS EXCAVATED MATERIAL: Excess excavated material shall be removed from the site and disposed of by the Contractor at his own expense. Excavated material including pavement, base, rock and subgrade soils, shall be removed from the job site at the end of the workday. Failure to do so will result in the CITY removing material at the Contractor's expense. Cost shall be calculated at actual cost for labor and equipment plus administrative charges.

Full compensation for conforming to the requirements in this article shall be considered as included in the prices bid for the various contract items of work involved and no additional compensation will be allowed therefor.

ARTICLE 11.05 STORAGE OF MATERIALS: The Contractor shall at all times carefully and properly protect all materials of every description both before and after being used in the work and provide any enclosing or special protection from the weather as deemed necessary by the Engineer.

Full compensation for conforming to the requirements in this article shall be considered as included in the prices bid for the various contract items of work involved and no additional compensation will be allowed therefor.

ARTICLE 11.06 SOLID WASTE COLLECTION: If collection of solid waste shall occur during street construction, the Contractor shall assist the solid waste collection contractor in accessing containers for his collection of solid waste.

Full compensation for conforming to the requirements in this article shall be considered as included in the prices bid for the various contract items of work involved and no additional compensation will be allowed therefor.

ARTICLE 11.07 APPURTENANT WORK: All items in the proposal form are considered as complete in place including all incidental and appurtenant work and materials necessary for the satisfactory completion of the same.

Full compensation for conforming to the requirements in this article shall be considered as included in the prices bid for the various contract items of work involved and no additional compensation will be allowed therefor.

ARTICLE 11.08 STORAGE YARD: The Contractor shall at his expense provide a storage yard for his equipment, tools, and materials to be stored. Location of storage yard shall be approved by the Engineer. CITY streets are not to be used as a storage area/yard.

Full compensation for conforming to the requirements in this article shall be considered as included in the prices bid for the various contract items of work involved and no additional compensation will be allowed therefor.

ARTICLE 11.09 PUBLIC UTILITIES: It is the Contractor's responsibility to notify Underground Service Alert (USA) to locate facilities prior to beginning the work. In addition, the Contractor shall locate service laterals that may be affected by the work and take measures to protect all utilities and service laterals in the streets and parkways.

The Contractor shall determine for himself the exact location of all public and private utilities, facilities or substructures, which are not shown on the plans. In the event any utility, facility or substructure is disturbed or damaged, whether in its original or relocated position, the Contractor shall immediately cause repairs to be made to the satisfaction of the owner at no cost to the CITY.

The Contractor shall notify the utility companies at least forty-eight (48) hours prior to construction.

AT&T	YVETTE GAROFANO	(714) 618-9146
CALIFORNIA DOMESTIC WATER COMPANY	CHE VENEGAS	(562) 947-3811
CHEVRON USA	DAVE ZERLER	(310) 669-4014
CITY OF LA HABRA PARKS DEPT	DAVID VILLALBA	(562) 383-4170
CITY OF LA HABRA SEWER AND WATER DEPT	BRIAN JONES	(562) 383-4170
COMCAST CABLE COMPANY		(800) 501-5738
CRIMSON PIPELINE	APRIL HARVEY	(562) 285-4195
CR&R (WASTE HAULER)		(714) 372-8209
FRONTIER COMMUNICATIONS	ARIEL FATALA	(714) 375-6717
KINDER MORGAN	DON QUINN	(714) 560-4400
LA HABRA HEIGHTS WATER COMPANY		(562) 697-6769
METROPOLITAN WATER DISTRICT	MATT PARRY	(714) 577-5084
MOBIL OIL	RUTH CRONIN-FRUITT	(310) 212-1761
ORANGE COUNTY SANITATION DISTRICT	DANIEL LEE	(714) 593-7176
PLAINS ALL AMERICAN PIPELINE	JOE MATTEO	(562) 728-2368
SO CAL EDISON	JIMMY PARKIN	(714) 578-3434
SO CAL GAS	JASON MORTON	(213) 312-5735
SHELL PIPE COMPANY	MALDONADO	(310) 816-2063
SPECTRUM	PARKER YEE	(562)677-0213
SUBURBAN WATER SYSTEMS	JAMES CHO	(626) 543-2548
TORRANCE LOGISTICS COMPANY	TERI A. SHINDE	(310) 212-1794

UNOCAL	ARNA ADAMS	(213) 864-5663
WESCON C/O VINTAGE		
PRODUCTION	EMILIO RODRIGUEZ	(562) 665-9255
UNDERGROUND SERVICE ALERT		(800) 422-4133

Full compensation for conforming to the requirements in this article shall be considered as included in the prices bid for the various contract items of work involved and no additional compensation will be allowed therefor.

ARTICLE 11.10 RESTORATION OF IMPROVEMENTS: The Contractor shall restore the construction site per the Greenbook (SSPWC) Section 7-9. All damage done to existing facilities and improvements by the Contractor shall be repaired by him to the satisfaction of the Engineer. All paint marks shall be removed at the end of the project by using an approved blasting method.

Lawn areas disturbed by the construction area shall be graded smooth and level with the adjacent lawn. All dirt clumps greater than one inch in size shall be crumbled or removed and all stone or rock shall be removed. The disturbed area shall be replaced with sod of a variety similar to the adjacent lawn. Shrubs destroyed or removed shall be replaced in kind to the satisfaction of the adjacent property owner. Paved areas shall be restored in kind to the satisfaction of the adjacent property owner. All fences disturbed, damaged or removed shall be restored to the satisfaction of the Engineer. In areas of close quarters, the Contractor shall excavate by hand. Facilities damaged by using power tools shall be replaced to the satisfaction of the adjacent property owner. Cement concrete sidewalks removed or damaged shall be saw-cut and removed to the nearest score mark and replaced in accordance with Article 12.14. Any other improvements disturbed shall be restored to its original conditions and to the satisfaction of the adjacent property owner. Sprinklers and irrigation lines disturbed by the construction operations shall be restored to their original condition or better to the satisfaction of the adjacent property owner and/or Engineer.

Full compensation for conforming to the requirements in this article shall be considered as included in the prices bid for the various contract items of work involved and no additional compensation will be allowed therefor.

ARTICLE 11.11 WASTE MANAGEMENT: The Contractor shall comply with the requirements of AB939 and City of La Habra Construction and Demolition Ordinance, and submit a Waste Management Plan for the approval of the Engineer.

Full compensation for conforming to the requirements in this article shall be considered as included in the prices bid for the various contract items of work involved and no additional compensation will be allowed therefor.

ARTICLE 11.12 BID SCHEDULE: The quantities and sizes of materials shown in the bid schedule are for bid purposes only. The actual quantities used for construction and payment purposes shall be measured and determined by the CITY.

ARTICLE 11.13 EARTHWORK: Earthwork shall conform to the requirements of Section 300, "Earthwork" of the Standard Specifications and shall include all clearing and grubbing, demolition, saw-cut, excavation, grading, removal, disposal, backfilling or any other work necessary to prepare the sub-grade for construction of improvements.

Subdivision 11.13.1 Clearing and Grubbing: Clearing and grubbing shall conform to the applicable portions of Section 300, "Earthwork" of the Standard Specifications. All PCC and asphalt concrete to be removed shall be sawcut as needed to provide straight clean joints.

The tasks included as part of clearing and grubbing include the following:

1. Removal and restoration, replacement or relocation of fences, planters, foundations, walls, vegetation and irrigations systems not included as part of other bid items.
2. Protection of existing utilities, trees, fences, walls, signs and other facilities within the construction zone, except those directed to be removed or relocated.
3. Root pruning of tree roots and their disposal in areas where roots are causing lifting of existing concrete improvements. Work is to be as advised by the City Arborist.

Full compensation for conforming to the requirements in this article shall be considered as included in the prices bid for the various contract items of work involved and no additional compensation will be allowed therefor.

ARTICLE 11.14 TRENCHING: (Public Contracts Code §7104) If the herein public works contract involves digging trenches or other excavations that extend deeper than four feet below the surface the Contractor shall promptly, and before the following conditions are disturbed, notify the local public entity, in writing, of any:

- (1) Material that the Contractor believes may be material that is hazardous waste, as defined in Section 25117 of the Health and Safety Code, that is required to be removed to a Class I, Class II, or Class III disposal site in accordance with provisions of existing law.
- (2) Subsurface or latent physical conditions at the site differing from those indicated by information about the site made available to bidders prior to the deadline for submitting bids.
- (3) Unknown physical conditions at the site of any unusual nature, different materially from those ordinarily encountered and generally recognized as inherent in work of the character provided for in the contract.
- (4) The CITY shall promptly investigate the conditions, and if it finds that the conditions do materially so differ, or do involve hazardous waste, and cause a decrease or increase in the Contractor's cost of, or the time required for, performance of any part of the work shall issue a change order under the procedures described in the contract.
- (5) That in the event that a dispute arises between the CITY and the Contractor whether the conditions materially differ, or involve hazardous waste, or cause a decrease or increase in the Contractor's cost of, or time required for, performance of any part of the work, the Contractor shall not be excused from any scheduled completion date provided for by the contract, but shall proceed with all work to be performed under the contract. The Contractor

shall retain any and all rights provided either by contract (Section 6.01.6 of the herein Special Provisions) or by law which pertain to the resolution of disputes and protests between the contracting parties.

Trench excavation shall include, without classification, the removal of all materials of whatever nature encountered, including all asphalt or other obstructions of every nature that would interfere with the proper execution and completion of the work. The Contractor shall furnish, place and maintain all supports and shoring as set forth in the rules, orders and regulations of the Division of Industrial Safety of the State of California. The Contractor shall supply all pumping, ditching or other approved measure to effect the removal or exclusion of water, storm water and/or wastewater reaching the site of the work from any source so as to prevent damage to the work.

Full compensation for conforming to the requirements in this article, including but not limited to all saw cutting, trench excavation, moving and proper disposal of the excavated material, disposal fees, pumping, shoring, backfill, pipe zone material, backfill material, temporary AC pavement and related items shall be considered as included in the prices bid for the various contract items of work involved and no additional compensation will be allowed therefor.

ARTICLE 11.15 PUMPING: All excavations shall be kept free of water while concrete or pipe is being placed and until concrete has attained its initial set to eliminate any possible damage from such water. Any water accumulations in excavations from any source whatsoever shall be removed by the Contractor at his own expense. Wastewater shall be removed with a vacuum truck and disposed of offsite in such a manner that it will not cause any damage to public or private property or will not be a menace or inconvenience to the public. This article does not construe that groundwater is present. Field investigations have not been made to obtain water table depth.

Included as part of this article is removal and proper disposal of removed materials.

Full compensation for conforming to the requirements in this article shall be considered as included in the prices bid for the various contract items of work involved and no additional compensation will be allowed therefor.

ARTICLE 11.16 BACKFILLING AND COMPACTING: All excavations shall be backfilled to the level of the original ground surface unless otherwise shown on the plans or ordered by the Engineer.

Backfill around valve and valve box clusters shall be accomplished with sand (SE 30 or greater). The sand backfill shall be compacted by jetting. The trench, for a distance of five (5) feet each side of the valve box shall be filled with sand and compacted.

The trench shall be backfilled to a level six inches above the top of pipe with 1.5 sack sand-cement slurry. The remaining backfill shall be placed in horizontal layers per detail included herein. Each layer shall be moistened, tamped, puddled, rolled or otherwise compacted to maximum density per Greenbook requirements. The sand equivalent shall be certified by the Contractor. : 1.5 sack sand cement slurry backfill shall be placed at all tunnels and other locations that are impractical to

achieve base compaction. Slurry shall be placed from top of bedding material to bottom of pavement surface.

Full compensation for conforming to the requirements in this article shall be considered as included in the prices bid for the various contract items of work involved and no additional compensation will be allowed therefor.

ARTICLE 11.17 SAND CEMENT SLURRY BACKFILL: 1.5 sack cement slurry back fill shall be placed at all tunnels and other locations that are impractical to achieve base compaction. Slurry shall be placed from top of bedding material to bottom of pavement surface.

Full compensation for conforming to the requirements in this article shall be considered as included in the prices bid for various contract items of work involved and no additional compensation will be allowed therefor.

SECTION 12: BID ITEMS FOR MACY STREET REHABILITATION PROJECT:

ARTICLE 12.01: BID ITEM 1, MOBILIZATION, DEMOBILIZATION & CLEANUP: Mobilization, Demobilization & Cleanup shall include all labor, work, and materials necessary to mobilize and demobilize forces, equipment, and materials; obtain bonding, insurance, permits, licenses; and other work as necessary to prepare for the construction of the work. Compensation for Mobilization, Demobilization & Cleanup shall not exceed **Five Percent (5%)** of the total bid amount.

Additional Requirements part of Bid Item 1, Mobilization, Demobilization & Cleanup:

Contractor must apply for a No Fee Permit with the City of Whittier Public Works Department by contacting, Alfredo Hernandez at (562) 567-9500 to obtain the permit. Compensation for executing no fee permit and providing satisfactory insurance requirements set forth by City of Whittier shall also be included in this bid item.

The Contractor must obtain an encroachment Dual permit from Caltrans and shall satisfy all permit requirements set upon them by Caltrans including procuring insurance required by Caltrans. The Contractor shall coordinate with Caltrans as necessary for work within and adjacent to State highways, including obtaining a Caltrans Encroachment Dual Permit, obtaining and providing satisfactory insurance set forth by Caltrans, and paying for Caltrans permit fees and inspection costs. All work necessary (including signal work, paving, BMPs, traffic control plan, and traffic control labor and equipment) to coordinate with Caltrans shall be incidental and included in the Mobilization/Demobilization.

The Contractor shall include in his bid prices as an incidental cost an allowance for inspection fees in accordance with the Caltrans Permit.

Compensation for Mobilization shall not exceed **Five Percent (5%)** of the total bid amount. Full compensation for complying with the work contained in this article for MOBILIZATION,

DEMOBILIZATION & CLEANUP (BID ITEM 1) shall be considered included in the contract bid price per Lump Sum (LS), and no additional compensation will be allowed therefor. One half of the bid amount shall be paid upon beginning work and completion of at least ten percent (10%) of the other bid items. One half shall be paid upon completion of the work, punch-list items, and complete cleanup and restoration of the project site. Compensation for Mobilization, Demobilization & Cleanup shall not exceed **Five Percent (5%)** of the total bid amount.

ARTICLE 12.02: BID ITEM 2, TRAFFIC CONTROL AND PUBLIC NOTIFICATION: The Contractor is directed to Subdivision 11.01.3 “Public Convenience and Access” and Subdivision 11.01.4 “Public Notice” as part of this article. The Contractor shall be responsible for adequate barricading of the work area and controlling of traffic in the vicinity of the project as specified in Section 5-7 “Safety” in the Standard Specifications and these Special Provisions or as directed by the Engineer. Compensation for Traffic Control and Public Notification shall not exceed **Five Percent (5%)** of the total bid amount.

The Contractor’s operations shall cause no unnecessary inconvenience. The access rights of the public shall be considered at all times. Unless otherwise authorized, traffic shall be permitted to pass through the Work, or an approved detour shall be provided.

NOTE: The Contractor is notified that this work is in the vicinity of, and along the route of, the following schools: **Macy Elementary School, 2301 Russell St, La Habra, CA 90631**. The Contractor shall take sufficient precautions to protect his work and the traveling public, especially during school hour commutes and events. The contractor shall schedule there paving operation outside of school hours.

Prior to construction, the contractor shall submit a full TCP signed by a traffic engineer to Caltrans along with an application for an encroachment permit for review and approval. Compensation for submitting acceptable TCP to Caltrans is considered included in this bid item and no additional compensation will be allowed. The Contractor shall also submit to the City Engineer for approval, a traffic control plan signed by a Traffic Engineer or a P.E. and a construction phasing plan. The traffic control plan shall include, but not be limited to, location of all temporary signs, barriers, flashing arrow boards and proposed traffic flow diagrams. The information shall include the minimum requirements of the State of California Manual of Uniform Traffic Control Devices (MUTCD), latest edition. The TCP shall be signed and stamped by either a Traffic Engineer (T.E.) or Professional Civil Engineer (P.E.), registered in the State of California and submitted by the Contractor to the CITY for approval.

The Contractor shall furnish at his expense and with no extra cost to the CITY such flagmen and guards as are necessary to give adequate warning to the public that roadway work is underway and of any dangerous conditions to be encountered. Flagmen shall perform their duties and be provided with equipment in accordance with current “Flagging Instruction Handbook” of the State of California, Department of Transportation. The equipment shall be furnished, kept clean and in good repair by the Contractor at his own expense. The Contractor shall furnish, erect, maintain and regularly inspect barricades, lights, signs and other devices as are necessary to prevent accidents and avoid damage or injury to the public. These devices shall conform to the

requirements set forth in the current “Manual of Warning Signs, Lights and Devices for Use in Performance of Work Upon Highways”, issued by the State of California, Department of Transportation or State of California Manual of Uniform Traffic Control Devices (MUTCD), latest edition.

All traffic control devices (delineators, signs, etc.) must be picked up at the end of the workday and stored off-site at an approved location. Traffic control devices may not be left overnight in the medians, at the curb, on sidewalks, etc. All graffiti on construction traffic control devices (delineators, signs, etc.) must be removed daily, or the signs be replaced.

Traffic control shall limit travel on only the specific work area for each day.

The roadway shall have at least one lane open in both directions at all times.

Parking shall be restricted only as needed for the specific work area for each day, and shall be reopened at the end of each work day. Parking restrictions may be from 7:00 AM to 4:00 PM on working days.

Through lanes and parking shall be restored by 4:00 PM each working day.

Trench plates shall be H20 load rated, skid resistant, and shall have traffic markings as needed to designate existing lane lines.

Before excavating through traffic loops, Contractor shall notify the Caltrans and have the signal placed on timed cycles. Loops shall be restored as soon as practicable.

Closures and parking restrictions shall only be made for the amount of time necessary to complete construction activities. Areas that do not have active construction work shall be secured and reopened as directed by the Engineer. Extents of closures and parking restrictions shall be limited to areas as necessary for immediate construction activities. Contractor shall install temporary “No Parking” and “Tow Away” signs.

When necessary to provide vehicular or pedestrian crossings over the fresh pavement, the Engineer shall direct the Contractor to spread sufficient sand or rock dust on the affected area to eliminate tracking or damage to the pavement. Sand or rock dust used for this purpose shall be at the Contractor’s expense.

Safe and adequate pedestrian and vehicular access shall be provided and maintained to: fire hydrants; commercial and industrial establishments; churches, schools, and parking lots; service stations and motels; hospitals; police and fire stations; and establishments of similar nature. Access to these facilities shall be continuous and unobstructed unless otherwise approved by the Engineer.

Safe and adequate pedestrian zones and public transportation stops, as well as pedestrian crossings of the Work at intervals not exceeding 300 feet in each direction, shall be maintained unless otherwise approved by the Engineer.

Vehicular access to residential driveways shall be maintained to the property line except when necessary construction precludes such access for reasonable periods of time. If backfill has been completed to the extent that safe access may be provided, and the street is opened to local traffic, the Contractor shall immediately clear the street and driveways and provide and maintain access.

The Contractor shall provide temporary AC ramps where there are differences at removals and/or cold mills. Ramps shall be provided in advance of opening the lane to vehicular travel.

Note: The ramp replacement at the NW corner of Macy/Russell. The Contractor's work shall not affect school traffic at no additional cost to the City.

Grading operations, roadway excavation and fill construction shall be conducted by the Contractor in a manner to provide a reasonably satisfactory surface for traffic. When rough grading is completed, the roadbed surface shall be brought to a smooth, even condition satisfactory for traffic.

Unless otherwise authorized, work shall be performed in only one-half the roadway at one time. One half shall be kept open and unobstructed until the opposite side is ready for use. If one-half a street only is being improved, the other half shall be conditioned and maintained as a detour.

Contractor shall include the scheduling and required Traffic Control & Construction Phasing for all construction activities and shall provide a schedule to the Engineer for review prior to the construction. The Contractor is to provide and distribute notices to the impacted properties seven (7) calendar days in advance of construction. Contractor shall also post "No Parking" signage forty-eight (48) hours prior to the intended construction. The signage shall provide the date and time that vehicles are prohibited from on street parking.

Solar/battery powered Changeable Message Signs (CMS) shall be placed in advance of the project, one (1) CMS is required at Whittier Blvd and Macy Street. The CITY shall direct the Contractor on the language of the message. The CMS shall be installed a minimum of one (1) month before the project starts, and the CITY has the right to make changes to the message at any time and at no additional cost to the CITY.

The Contractor shall cooperate with the various parties involved in the delivery of mail, residents attempting to enter or exit, and the collection and removal of trash and garbage to maintain existing schedules for these services.

Full compensation for conforming to the requirements in this article TRAFFIC CONTROL AND PUBLIC NOTIFICATION (BID ITEM 2), shall be considered as included in the contract bid price per Lump Sum (LS), and shall include all labor, tools, materials, and appurtenances necessary to complete the work and no additional compensation will be allowed therefor. Compensation for Traffic Control and Public Notification shall not exceed **Five Percent (5%)** of the total bid amount.

ARTICLE 12.03: BID ITEM 3, CONSTRUCTION SURVEYING AND MONUMENT PRESERVATION: The Contractor shall provide all labor, tools, work, materials and appurtenances necessary to survey the work to conform to plan lines and limits, provide

grades for drainage, establish pavement grades, match to existing conditions, and otherwise lay out the work as necessary for construction. The Contractor shall review and set all reference points, grades and elevations to the satisfaction of the Engineer prior to construction operations.

Pavement grades shall be provided as necessary for PCC construction, and to prepare the street for asphalt pavement operations. Grades shall provide for adequate drainage, match to existing slopes, gutters and other improvements, and provide a smooth profile. Nominal pavement grades shall be 2% from the pavement centerline to edge of gutter. In locations where gutter elevations differ on each side of the street, the slope shall be adjusted to provide adequate drainage, but shall not be less than 1% or more than 4%, and shall be approved by the Engineer.

Prior to the start of construction, the Contractor's licensed Land Surveyor or registered Civil Engineer licensed to practice land surveying in the State of California shall, in conformance with California State Law AB 1414, locate all monuments (whether or not of record), bench marks, and centerline ties within the construction zone, i.e., within one hundred feet of the construction activity. Additional ties to monuments shall be set when ties are missing (min. 4 ties per monument.) The Contractor's Licensed Surveyor or qualified Civil Engineer shall prepare and submit for review to the Engineer separate tie sheets and Corner Record sheets (monuments not of record shall have only tie sheets prepared). Tie sheets and Corner Records shall conform to the County Standards and the County Engineers' Association of California's "Guide to the Preparation of Records of Survey and Corner Records" document as provided by the County of Orange Land Surveyor's Office. Upon review by the Engineer, the Land Surveyor shall file the Corner Records with the County of Orange Land Surveyor's Office as required by law, and file Certified Corner Records with the City Engineer.

After construction and prior to final acceptance by the CITY of the construction project, the Contractor's land surveyor or qualified Civil Engineer shall re-survey all field monuments and centerline ties within the construction zone, prepare tie sheets and Corner Record sheets as indicated above, and file them with the City Engineer for review. After review by the City Engineer, the land surveyor shall file the Corner Records with the County of Orange Land Surveyor's Office as required by law, and file certified copies of the Corner Records with the City Engineer.

The Contractor shall not disturb any monuments, stakes or sign posts found on the line of the improvement until authorized by the Engineer. The Contractor shall bear the expense of resetting any monument, stakes or sign posts which may be disturbed without authorization from the Engineer. All survey monuments removed or altered as a result of construction shall be reset, Corner Records filed with the County of Orange Land Surveyor's Office, and approved final Corner Records filed with the City Engineer. Centerline ties removed as a result of construction shall be reset and tie sheets filed with the City Engineer.

The Contractor is responsible to re-establish any survey monument that is disturbed, including monuments at the property line with no extra cost to the CITY to the satisfaction of the City Engineer.

The land surveyor shall provide a letter of certification for all monuments having four or more existing ties which are within 0.02 feet plus or minus of the original CITY tie sheet records. When several monuments or ties appear on one tie sheet and one of the ties has changed, the land surveyor shall re-measure all of the ties and re-file a new tie sheet with the CITY as required herein.

County of Orange permanent and temporary bench marks within the construction zone shall be located by survey, and the Contractor's Land Surveyor shall send a written notification of impending construction to the County of Orange Land Surveyor's Office two weeks prior to construction.

Lines and grades for the construction shall be the responsibility of the Contractor, with the following provisions:

All work under this contract shall be built in accordance with the lines and grades shown on the plans. Field survey for establishing these, and for the control of construction, shall be the responsibility of the Contractor. All such survey work including construction staking shall be done under the supervision of a California Licensed Land Surveyor or authorized Civil Engineer. Staking shall be done on all items ordinarily requiring grade and alignment, at intervals normally accepted by the agencies and trade involved.

The Contractor shall provide a copy of the office calculations and grade sheets to the Engineer. The Contractor shall be responsible for any errors in the finished work, and shall notify the Engineer, in writing, within twenty-four (24) hours, of any discrepancies, or design errors during the construction staking.

Contractor shall provide construction surveying for relocation of any conflicting utilities and provide a reasonable time window of opportunity to the utility owners to relocate their facilities after the survey is provided by the Contractor.

Construction shall not begin until the Preliminary Corner Records are submitted to the City.

Project retention will not be released until all records are recorded with the County of Orange Land Surveyor's Office.

Full compensation for conforming to the requirements in this article CONSTRUCTION SURVEYING AND MONUMENT PRESERVATION shall be considered as included in the contract bid price Lump Sum for (BID ITEM 3) for the project , and shall include, but not be limited to, construction staking, location and/or relocation of conflicting utilities, locating survey monuments, setting of survey monuments and center lines ties, preparing and filing centerline tie sheets and Corner Records, locating bench marks and notifying the County Surveyor's Office of same, professional office services and field calculation, and furnishing all labor, tools, materials, equipment and appurtenances necessary to complete the work and no additional compensation will be allowed therefor.

ARTICLE 12.04: BID ITEM 4, STORM WATER BEST MANAGEMENT PRACTICES (BMPs): The Contractor shall comply with Section 3-12 “Work Site Maintenance” of the Standard Specifications for Public Works Construction. The Contractor shall not permit polluted water to enter a catch basin or drainage channel. Water pollution control work shall consist of constructing those facilities which may be shown on the Plans, specified elsewhere in these Special Provisions, required by the Standard Specifications, required by National Pollutant Discharge Elimination System (NPDES No. CAS000002) California General Permit for Storm Water Discharges Associated with Construction and Land Disturbance Activities Order No. 2009-0009-DWQ, or ordered by the Engineer. Said work is intended to provide prevention, control and abatement of water pollution to streams, waterways and other bodies of water.

In order to provide effective and continuous control of water pollution, it may be necessary for the Contractor to perform the contract work in small or multiple units on an out-of-phase schedule and with modified construction procedures. The Contractor shall provide temporary pollution control measures including, but not limited to, dikes, basins, ditches and the application of straw and seed which become necessary as a result of his operations. The Contractor shall coordinate water and pollution control work with all other work done on the contract.

Before starting any work on the project, the Contractor shall submit to the Engineer for acceptance a Water Pollution Control Plan (WPCP) for effective control of water pollution. Such WPCP shall show the schedule for the erosion control work included in the contract and for all water pollution control measures which the Contractor proposes to take in connection with construction of the project to minimize the effect of his operations upon adjacent streams and other bodies of water. The Contractor shall not perform any clearing and grubbing, or earthwork on the project, other than that specifically authorized in writing by the Engineer, until such WPCP has been accepted. The Contractor shall revise and bring up to date said WPCP at any time the Engineer makes written request for such revision.

The Engineer will notify the Contractor of the acceptance or rejection of any submitted or revised WPCP in not more than ten (10) days.

The CITY shall not be liable to the Contractor for failure to accept all or any portion of an originally submitted or revised WPCP, nor for any delays to the work due to the Contractor’s failure to submit an acceptable WPCP.

The Contractor may request the Engineer to waive the requirement for submission of a written WPCP for control of water pollution when the nature of the Contractor’s operation is such that erosion is not likely to occur. Waiver of this requirement will not relieve the Contractor from responsibility for compliance with the other provisions of this section. Waiver of the requirement for a written WPCP for control of water pollution will not preclude submittal of a written WPCP at a later time if the Engineer deems it necessary because of the effect of the Contractor’s operations.

Where erosion control damage will cause water pollution which is probably due to the nature of the material or the season of the year, the Contractor’s operations shall be so scheduled that

permanent erosion control features will be installed concurrently with or immediately following grading operations.

Compliance with the requirements of this article shall in no way relieve the Contractor from his responsibility to comply with the other provisions of the Contract, in particular, his responsibility for damage and for preservation of property.

All water pollution control work performed in accordance with the accepted WPCP which is not otherwise required under the contract and which is ordered by the Engineer will be paid for as follows:

- (1) Such water pollution control work which may be accomplished under the various contract items of work will be measured and paid for as provided for in these Special Provisions for the said items of work.
- (2) Such water pollution control work not covered by contract items will be paid for as extra work as provided for in Section 7-4 "Payment for Extra Work" of the Standard Specifications.

Full compensation for conforming to the requirements in this article STORMWATER BEST MANAGEMENT PRACTICES (BMPs) shall be considered as included in the contract bid price Lump Sum for **(BID ITEM 4)** for the project , and shall include, but not be limited to, planning, placing maintaining and restoration of storm water BMP's as required during construction, and furnishing all labor, tools, materials, equipment and appurtenances necessary to complete the work and no additional compensation will be allowed therefor.

ARTICLE 12.05: BID ITEM 5, COLD MILL EXISTING AC PAVEMENT TO 2" DEPTH:

This bid item shall include all labor, tools, materials, and appurtenances necessary to cold mill 2" depth of asphalt concrete pavement. Cold milling shall conform to Subsection 302-1 of the Standard Specifications and as indicated in these Special Provisions.

Existing asphalt concrete shall be milled at the locations and to the dimensions shown on the plans and in accordance with these Special Provisions. The milling of asphalt concrete pavement shall be performed by cold milling. The cold milling machine shall have a cutter head at least 30 inches wide and shall be operated so as not to produce fumes or smoke. The depth, width and shape of the cut shall be as indicated on the typical cross sections or as directed by the Engineer. The final cut shall result in a uniform surface conforming to typical cross sections. The outside lines of the milled area shall be neat and uniform. The road surfacing to remain in place and other improvements in the public right-of-way or on private property shall not be damaged in any way. The Contractor shall use extreme caution when cold milling adjacent to the existing gutters, so as not to cause chipping and breakage of the concrete. The Contractor shall be responsible for the replacement of any and all concrete improvements damaged during the milling process.

The Contractor shall be responsible to locate and mark all facilities such as sewer manhole covers, telephone manhole covers, water valve covers, and catch basin covers, which, if struck, could damage the cold milling cutting drum and/or cutting teeth. The Contractor shall thoroughly inspect

the work site in advance of the cold milling operation to minimize the risk of striking any unseen under surface object(s) and shall include in the price(s) bid for edge milling removal work an additional amount sufficient to cover the cost of damage related down time and the cost of repair of damage to said cold milling cutting drum and/or cutting teeth.

The material milled from the roadway surface, including material deposited in existing gutters or on the adjacent traveled way, shall be immediately removed from the site of the work and disposed of outside the road right-of-way. The removal crew shall follow within fifty (50) feet of the miller unless otherwise directed by the Engineer. Residue from grinding shall not be permitted to flow or travel into gutters, onto adjacent street surfaces or parkways. All residue shall be immediately and completely removed by broom and properly disposed of. No washing of residue into drainage structures will be allowed. Cold milled materials shall become the property of the Contractor.

Both the perpendicular and parallel temporary taper transition may be achieved by over milling outside of the specified full depth mill limits or by using a full depth mill inside the specified full depth mill limits followed by a temporary asphalt concrete ramp. **The temporary asphalt concrete ramp must be removed prior to the actual asphalt concrete base course placement.** Adherence to all of the preceding temporary pavement surface maintenance requirements shall be absorbed into the unit costs for the various mills. Temporary ramping, where required by the Engineer for traffic control or other purposes, shall be considered included in this article and no additional compensation will be allowed.

In areas where new asphalt pavement will join existing asphalt pavement, the Contractor shall sawcut edges to ensure a clean joint to existing asphalt pavement and as shown on the plans.

Milled asphalt concrete pavement will be measured by the square foot. The quantity to be paid for will be the actual area of surface milled irrespective of the number of passes required.

Full compensation for conforming to the requirements in this article COLD MILL EXISTING AC PAVEMENT TO 2" DEPTH (BID ITEM 5), shall be considered as included in the contract bid price per Square Foot (SF), and shall include all labor, tools, materials, and appurtenances necessary to complete the work, including costs for trucking and disposing of material, and no additional compensation will be allowed therefor.

ARTICLE 12.06: BID ITEM 6, UNCLASSIFIED EXCAVATION AND DISPOSAL. LOCAL DIGOUTS. REMOVE EXISTING TO 12" DEPTH, SCARIFY, COMPACT BASE AND REGRADE.: This bid item shall include all labor, tools, materials and appurtenances necessary to complete the work necessary as part of this article which shall include, but not be limited to, sawcut, remove existing roadway structural asphalt concrete pavement, base aggregate, landscaping improvements and/or subgrade soils as necessary to prepare for placement of AC pavement per plans.

The removal of pumping soil, if encountered, shall also be included in roadway excavation. Limits of additional removals due to pumping soil shall be specified by the Engineer.

Excavation, grading and backfill shall be done in conformance with the applicable portion of Section 300 "Earthwork" of the Standard Specifications and shall include any necessary excavation, and/or fill within the right-of-way, including imported material grading of area to finish subgrade ready for improvements, as shown on the plans or as directed by the Engineer.

The Contractor shall comply with Section 300-2.6, "Surplus Material", and shall furnish written consent from the owner of the property where it is intended to dispose of the surplus material.

When the exposed subgrade within 1.0 foot of the grading plane has a relative compaction of less than ninety percent (90%), the subgrade shall be scarified and recompacted in accordance with the provisions of the Standard Specifications and the relative compaction shall not be less than ninety percent (90%). All aggregate base material shall be compacted to 95 percent (95%) of relative maximum density. Tests for the compliance may be made by a representative of the CITY, at the expense of the CITY, using Test Method No. California 231. In the event the initial test fails, additional tests shall be made at the Contractor's expense.

Backfill material and placement shall conform to the applicable portions of Section 300 of the Standard Specifications.

Localized reconstruction of pavement sections shall be completed prior to 2" grind of Macy Street.

The two asphalt driveways located at 1251 Macy Street, Station 24+00, shall be a 6" unclassified excavation, and a 4" Base Course, B PG-64-10, with a 2" ARHM PG 64-16 Cap. Unclassified excavation for the driveways is part of this bid item.

Full compensation for conforming to the requirements in this article ROADWAY EXCAVATION UNCLASSIFIED EXCAVATION AND DISPOSAL. LOCAL DIGOUTS. REMOVE EXISTING TO 12" DEPTH, SCARIFY, COMPACT BASE AND REGRADE (BID ITEM 6), shall be considered as included in the contract bid price per Cubic Yard (CY) measured volumetrically, and shall include all labor, tools, materials and appurtenances necessary to complete the work and no additional compensation will be allowed therefor.

ARTICLE 12.07: BID ITEM 7 - CONSTRUCT HEADER BOARD WITH STAKES: The contract bid item to furnish, construct the Header Board (Redwood Header 2" by 4") and stakes include all labor, work and materials necessary to remove existing materials, grade and backfill as required and construct the redwood header complete in place. The Contractor shall sawcut and remove existing asphalt, landscape and other materials, base, subgrade, and other in-place materials as necessary for construction; prepare the subgrade; grade; and construct the redwood header. Stakes shall be placed at 2 feet on-center at 12 inch depth.

Header board shall be installed on west side of street approximately between station 10+50 to 12+00 and at edges of both asphalt driveways at address 1251 Macy Street.

The bid item may be increased or reduced at the discretion of the City. The provisions of Section 2-7.1 of the Greenbook governing increases or decreases in quantity of more than 25% shall not

apply to this item. Unit prices shall continue to apply to the increased or decreased quantities for more and less than twenty-five percent (25%).

Full compensation for complying with the work contained in this section shall be included in the contract price bid per LINEAR FOOT (LF) to CONSTRUCT HEADER BOARD WITH STAKES (BID ITEM 7), and no additional compensation will be allowed therefore.

ARTICLE 12.08: BID ITEM 8, INSTALL 6" CMB FINE GRADE, SCARIFY AND COMPACT BASE: Work under this item shall include all labor, materials, equipment and incidentals required for AC preparation, installation of Tack coat, compaction and protection of work, and all other work associated with this task, complete and in place. The Contractor shall furnish to the Engineer at the time of delivery of the material on the job site a legible copy of a licensed weighmaster's certification showing gross, tare and net weights of each truckload of asphalt concrete mixture. Material that is delivered but not placed within the allotted bid item will not be measured or paid for. This work item shall include all surface preparation and weed abatement as well as labor, materials and work required to fully complete the noted item of work. Measurement and payment for work under this item shall be at the contract unit price per TON, as measured from the delivered material tickets for material actually installed.

Full compensation for conforming to the requirement in this article INSTALL 6" CMB FINE GRADE, SCARIFY AND COMPACT BASE (BID ITEM 8), shall be included in the contract unit price bid per ton (TON), based upon **certified weigh master tickets**. The unit price shall include all surface preparation, tack coat, rock dust blotter, labor, tools, equipment, materials, and incidentals required to complete the work. No additional compensation will be allowed.

ARTICLE 12.9: BID ITEM 9, INSTALL 4" THICK ASPHALT CONCRETE BASE COURSE (B PG 64-10)

This item in the bid price per Tons includes all labor, tools, materials and appurtenances necessary to lay the Asphalt Concrete Base Course as follows:

Asphalt concrete base course shall be Paving Asphalt, Type B PG 64-10, conforming to Section 203-1 as specified in Section 203.10.2.1 of the Standard Specifications (latest edition) per Typical Sections as shown on the plans, and shall conform to the following:

The Contractor shall submit a copy of the asphalt concrete mix design to the City or its designated laboratory a minimum of two weeks prior to the start of the construction.

Apply SS-1H tack coat at a rate not to exceed one-tenth (1/10) gallon per square yard uniformly in one coat on all vertical joints of AC patching and P.C.C. surfaces and edges against which Pavement Asphalt is to be placed. Diesel fuel shall not be used for cleaning purposes within the limits of this project.

B PG 64-10 shall be thoroughly compacted by rolling. The number of rollers necessary will be established in accordance with Section 302-5.6.1 of the Greenbook Specifications. All compacted B PG 64-10 shall have a relative compaction of not less than 95 percent in accordance with Section 302-5.6.2 of the Greenbook Specifications.

The two asphalt driveways located at 1251 Macy Street, Station 24+00, shall be a 6” unclassified excavation, and a 4” Base Course, B PG-64-10, with a 2” ARHM PG 64-16 Cap. The base course for the driveways is part of this bid item.

Full compensation for conforming to the requirement in this article INSTALL 4" THICK ASPHALT CONCRETE BASE COURSE (B PG 64-10), **(BID ITEM 9)**, shall be included in the contract unit price bid per ton (TON), based upon **certified weigh master tickets**. The unit price shall include all surface preparation, tack coat, rock dust blotter, labor, tools, equipment, materials, and incidentals required to complete the work. No additional compensation will be allowed.

ARTICLE 12.10: BID ITEM 10, INSTALL 2" THICK ASPHALT RUBBER HOT MIX (ARHM-GG-C PG 64-16) OVERLAY.

This item in the bid price per Tons includes all labor, tools, materials and appurtenances necessary to lay the Rubberized Asphalt as follows:

Asphalt concrete surface course shall be Asphalt Rubber Hot Mix, Type ARHM-GG-C, wet process, as specified in Section 203-11 and 302-9 of the Standard Specifications (latest edition), per Typical Sections as shown on the plans, and shall conform to the following:

Paving asphalt used for asphalt-rubber shall be performance grade PG 64-16. Composition and Grading shall be per Section 203-11.3 of the Standard Specifications (latest edition). The Contractor shall submit a copy of the asphalt concrete mix design to the City or its designated laboratory a minimum of two weeks prior to the start of the construction.

The Contractor shall place the ARHM a maximum of 48 hours after the commencement of all full width grinding operations during any stage of the work for this project.

Apply SS-1H tack coat at a rate not to exceed one-tenth (1/10) gallon per square yard uniformly in one coat on all vertical joints of AC patching and P.C.C. surfaces and edges against which ARHM is to be placed. Diesel fuel shall not be used for cleaning purposes within the limits of this project.

All surfaces to be overlaid shall be cleaned by the use of a broom and a vacuum sweeper. The overlaid surface shall be free of water, dust, or foreign material before tack is applied. All raised pavement markers shall be removed prior to the placement of any AHRM concrete overlay. Removal of all AC slurry seal residue from gutter lip should be completed prior to paving.

The Contractor shall utilize a paving machine equipped with an automatic adjusting screed, which is actuated by a 30-foot “ski”, for the entire ARHM-GG-C overlay.

ARHM-GG-C shall be thoroughly compacted by rolling. The number of rollers necessary will be established in accordance with Section 302-5.6.1 of the Greenbook Specifications. All compacted ARHM-GG-C shall have a relative compaction of not less than 95 percent in accordance with Section 302-5.6.2 of the Greenbook Specifications.

Rolling along a joint shall be such that the widest part of the roller is on the hot side of the joint. Join lines between successive runs shall be within 5 inches of lane lines or a minimum of 12 feet outside of the outermost lane line.

The Contractor shall provide for adequate quality control measures to ensure that delivery of asphalt rubber shall be neither too slow nor too fast to prevent stopping of the paving operation and/or cooling of the asphalt rubber material. Material delivery scheduling and handling is critical to provide for optimum compaction opportunity and maximize ride quality performance.

Rock dust blotter material shall be required immediately after the completion of the “finish rolling” and prior to opening to traffic to prevent bleeding and tracking of the asphalt rubber material.

Rock dust blotter shall be per Section 200-1.2 of the Standard Specifications and shall be uniformly applied using a mechanical spreader, which distributes uniformly at a rate of approximately three pounds per square yard. Compaction rollers shall not be allowed on the rock dust covered pavement surfaces. All excess rock dust blotter shall be removed from the street at the end of each workday.

The two asphalt driveways located at 1251 Macy Street, Station 24+00, shall be a 6” unclassified excavation, and a 4” Base Course, B PG-64-10 with a 2” ARHM PG 64-16 Cap. The ARHM cap for the driveways is part of this bid item.

Full compensation for conforming to the requirement in this article INSTALL 2" THICK ASPHALT RUBBER HOT MIX (ARHM-GG-C PG 64-16) OVERLAY. (BID ITEM 10), shall be included in the contract unit price bid per ton (TON), based upon **certified weigh master tickets**. The unit price shall include all surface preparation, tack coat, rock dust blotter, labor, tools, equipment, materials, and incidentals required to complete the work. No additional compensation will be allowed.

ARTICLE 12.11: BID ITEM 11, INSTALL PCC CURB & GUTTER PER SPPWC 120-3 A2-8: This bid item shall include all labor, materials, equipment, and work necessary to remove existing and construct new 8” concrete curb & gutter over 6” CMB per SPPWC 120-3 A2-8 with AC slot patch complete in place. If the curb height is higher than 8”, contract shall match height and this is considered included in the bid price. The Contractor shall saw-cut; excavate and remove existing in-place materials as necessary and properly dispose of material, subgrade, and concrete for new construction; compact subgrade; place 6” CMB; and construct new 8” curb and gutter. New curb and gutter finish shall match existing type, curb height and finish and shall maintain water flow through the flowline. Limits of construction shall be verified, measured, and marked in the field by the Engineer

prior to removing existing improvements. The Contractor shall construct an asphalt concrete slot twelve inches wide with length that matches the length of the new curb and gutter. Adjustment of any existing pipe openings, removal of existing pavement and base/subgrade, and the installation of the AC slot patch shall be included in the contract bid price. AC shall be 1' wide 8" depth unless stated otherwise on the plans.

Portland cement concrete material shall be Portland Cement Concrete of Type 520-C-2500. Slot Patch should be Type C2 PG 64-10. CMB shall be per Section 200-2.2 of Greenbook.

Station 11+05 to Station 11+35, 30 feet of curb and gutter, on the east side of the street shall be a variable height curb and gutter as needed with AC Slot Patch adjacent to gutter and back of curb; and is considered included in the price for this bid item.

The Contractor shall replace and repair any irrigation system damaged by his operation in all locations. In some locations, there may be tree roots that need to be removed for proper construction of the improvements. In these cases, the Contractor, at his own expenses, shall cut, remove, and properly dispose of the roots per Engineer instructions and per all applicable laws, rules and regulations. All work necessary to remove and properly dispose of all removed material shall be at no extra cost to the CITY.

Payment for root pruning within the limits of the curb and gutter shall be included in the contract bid price.

These pruning guidelines shall be followed by all persons or firms repairing or replacing damaged street, curbs, sidewalks, driveways, or access ramps where the damage is attributable to the roots of the trees growing in the public right-of-way. At least two (2) days prior to any digging or excavating, DigAlert and the Parks Department at 562-383-4170, must be notified.

The Contractor shall remove the concrete at all tree root locations and notify the Parks Department forty-eight (48) hours in advance prior to performing root pruning or selective root removal.

One of the following methods or a combination of methods shall be used when pruning or root removal of tree roots:

Whenever possible, root pruning should only be performed on one side of a tree at a time, meaning on the sidewalk side or street side, but not on both, unless specifically authorized by the City Arborist.

- a. Root Pruning: The actual pruning of roots should be done using a trenching machine, which operates in a vertical motion only, with a root pruning attachment or some comparable piece of equipment, which can safely cut a narrow trench four (4) to six (6) inches wide.
- b. Selective Root Removal: Root larger than three (3) inches in diameter shall be horizontally trimmed or selectively removed. The utilization of a chain saw, or other

sawing tool shall be employed during this procedure. This procedure shall be overseen by the City Arborist.

All tree activity shall be conducted in a manner specified by ANSI Z133.1 – 2006 Safety Requirements & ANSI A300 (Part 1)-2001 Standard Practices (Pruning).

If the report from the City Arborist recommends the tree be removed because necessary root pruning would be detrimental to the structural integrity of the tree, the Contractor will coordinate with the CITY for removal by CITY resources.

The Contractor shall paint the address of any house that is on a replaced curb with no extra cost to CITY to the satisfaction of the Engineer.

The CITY reserves the right to delete any item or items of the Exhibit A - Bid Schedule and to increase or decrease any quantities in the Bid Schedule as the Engineer directs in exclusion of the Standard Specification for Public Works Construction “the Green Book”. This exclusion shall include, but not be limited to, “Section 3 – Changes In Work” of the Green Book. The twenty-five percent (25%) Green Book rule on quantities of total arithmetic dollar value shall not apply to this project. Unit prices shall continue to apply to the increased or decreased quantities for more and less than twenty-five percent (25%).

No open excavations will be allowed over a weekend or holiday. The Contractor shall schedule work to accommodate this requirement. All concrete must be in place and forms removed prior to weekends and holidays.

Full compensation for conforming to the requirements in this article INSTALL PCC CURB & GUTTER PER SPPWC 120-3 A2-8 (BID ITEM 11) shall be considered as included in the contract bid price per Linear Foot (LF), and shall include 1' wide full depth (8") AC slot patch of the adjacent pavement, front or back or both, all labor, tools, materials, and appurtenances necessary to complete the work and no additional compensation will be allowed therefor.

ARTICLE 12.12: BID ITEM 12, REMOVE EXISTING & CONSTRUCT NEW ADA COMPLIANT CURB RAMP PER PLANS. This bid item shall include all labor, materials, equipment, and work necessary to remove existing and construct new PCC curb ramp with detectable warning surface over native per plan, unless otherwise noted, complete in place. The Contractor shall saw-cut and remove existing PCC sidewalk, curb access ramps, curbs, gutter, spandrels, sand, subgrade and other in-place materials as necessary and properly dispose of material, subgrade, and concrete for new construction; compact subgrade; and construct new PCC curb ramps with detectable warning surface where noted and as shown per detail drawings. New sidewalk shall match existing sidewalk finish and pattern as directed. **Bid item shall include curb ramp related sidewalk, retaining curb, curb, gutter, curb drain and 2' WIDE 8" FULL DEPTH AC slot patch. Additionally, all related adjustments of pull boxes, pull box covers, protection or sign replacements within construction limits shall be considered as part of the ramp work and shall be included in the contract bid price.** All work necessary beyond the ECR/BCR required to construct this ramp is considered included in the lump sum price.

New curb ramp finish shall match existing type, curb height and finish and shall maintain water flow through the flowline. Limits of construction shall be verified, measured and marked in the field by the Engineer prior to removing existing improvements. The Contractor shall construct an asphalt concrete slot twelve inches wide with length that matches the length of the new curb and gutter. Adjustment of any existing pipe openings, removal of existing pavement and base/subgrade, and the installation of the AC slot patch shall be included in the contract bid price. For curb ramps that are joined to a spandrel, the Contractor shall sawcut a neat line 4" from the existing curb face.

Portland cement concrete material shall be Portland Cement Concrete of Type 520-C-2500. Slot Patch should be Type C2 PG 64-10. CMB shall be per Section 200-2.2 of Greenbook but with the following modifications to Table 200-2.2.2:

- 3/4" Sieve (19.0 mm) shall have 100 percentage passing sieve
- 3/8" Sieve (19.0 mm) shall have 50-90 percentage passing sieve.

Integral retaining curbs shall be constructed at the back of curb ramps and sidewalks as necessary to match existing landscape grades or to match existing grades at a wall. Integral curbs, curb and gutter, and sidewalk shall be constructed as shown on the plans.

Curb access ramps and sidewalks shall meet all ADA requirements and shall not create impediments to access. Curb access ramps features, per standard plan, shall include:

Detectable warning surface shall conform to the standard plans and shall be cast in place Tactile Tile by Armor-Tile or approved equal, 3'x 5' minimum, extending the full width of ramp. Edge of detectable warning tile is to be 6" to 8" from the flowline at the bottom of the ramp and parallel to adjacent to the street or tangent to the curb return. The color of the detectable warning surface shall be YELLOW unless otherwise specified.

The Contractor shall submit to the Engineer for review the following items:

- A. Product Data: Submit manufacturer's literature describing products, installation procedures and routine maintenance.
- B. Samples: Submit two tile samples of the kind proposed for use (minimum size 6" by 8").
- C. Materials Test Reports: Submit test reports from qualified independent testing laboratory indicating that materials proposed for use are in compliance with requirements and meet the properties indicated. All test reports shall be conducted on a cast-in-place tactile tile system as certified by a qualified independent testing laboratory.
- D. Maintenance Instructions: Submit copies of manufacturer's specified maintenance practices for each type of tactile tile and accessory as required.

The manufacturer shall provide a written five year warranty for prefabricated detectable warning surfaces, guaranteeing replacement when there is defect in the dome shape, color

fastness, sound-on-cane acoustic quality, resilience, or attachment. The warranty period shall begin upon acceptance of the project.

The Contractor shall replace and repair any irrigation system damaged by his operation in all locations. In some locations, there may be tree roots that need to be removed for proper construction of the improvements. In these cases, the Contractor, at his own expenses, shall cut, remove, and properly dispose the roots per Engineer instructions and per all applicable laws, rules and regulations. All work necessary to remove and properly dispose of all removed material shall be at no extra cost to the CITY.

Payment for root pruning within the limits of the curb ramp shall be included in the contract bid price.

These pruning guidelines shall be followed by all persons or firms repairing or replacing damaged street, curbs, sidewalks, driveways, or access ramps where the damage is attributable to the roots of the trees growing in the public right-of-way. At least two (2) days prior to any digging or excavating, DigAlert and the Parks Department at 562-383-4170, must be notified.

The Contractor shall remove the concrete at all tree root locations and notify the Parks Department forty-eight (48) hours in advance prior to performing root pruning or selective root removal.

One of the following methods or a combination of methods shall be used when pruning or root removal of tree roots:

Whenever possible, root pruning should only be performed on one side of a tree at a time, meaning on the sidewalk side or street side, but not on both, unless specifically authorized by the City Arborist.

- c. Root Pruning: The actual pruning of roots should be done using a trenching machine, which operates in a vertical motion only, with a root pruning attachment or some comparable piece of equipment, which can safely cut a narrow trench four (4) to six (6) inches wide.
- d. Selective Root Removal: Root larger than three (3) inches in diameter shall be horizontally trimmed or selectively removed. The utilization of a chain saw or other sawing tool shall be employed during this procedure. This procedure shall be overseen by the City Arborist.

All tree activity shall be conducted in a manner specified by ANSI Z133.1 – 2006 Safety Requirements & ANSI A300 (Part 1)-2001 Standard Practices (Pruning).

If the report from the City Arborist recommends the tree be removed because necessary root pruning would be detrimental to the structural integrity of the tree, the Contractor will coordinate with the CITY for removal by CITY resources.

The CITY reserves the right to delete any item or items of the Exhibit A - Bid Schedule and to increase or decrease any quantities in the Bid Schedule as the Engineer directs in exclusion of the Standard Specification for Public Works Construction “the Green Book”. This exclusion shall include, but not be limited to, “Section 3 – Changes In Work” of the Green Book. The twenty-five percent (25%) Green Book rule on quantities of total arithmetic dollar value shall not apply to this project. Unit prices shall continue to apply to the increased or decreased quantities for more and less than twenty-five percent (25%).

No open excavations will be allowed over a weekend or holiday. The Contractor shall schedule work to accommodate this requirement. All concrete must be in place and forms removed prior to weekends and holidays.

Full compensation for conforming to the requirements in this article REMOVE EXISTING & CONSTRUCT NEW ADA COMPLIANT CURB RAMP PER PLAN. (BID ITEM 12), shall be considered as included in the contract bid price per Each (EA), and shall include all labor, tools, materials and appurtenances necessary to complete the work and no additional compensation will be allowed therefor. The Contractor shall be responsible to remove and reconstruct curb access ramps at his own cost if the ramps are deemed non-compliant with project plans and specifications.

ARTICLE 12.13: BID ITEM 13, SAWCUT AND REMOVE EXISTING DRIVEWAY APPROACH. CONSTRUCT NEW PCC DRIVEWAY APPROACH PER SPPWC 110-2 TYPE B.: This bid item shall include all labor, tools, materials and appurtenances necessary to remove existing and construct new concrete residential/commercial driveway approach per CITY Standard Detail SPPWC Standard Plan 110-2, Type B. The Contractor shall saw-cut, excavate and remove existing in-place materials as necessary and properly dispose of material, subgrade and concrete for new construction; compact subgrade,; and construct new driveway approaches. If CMB is needed it will be paid per the contract bid price, Item 8. The Contractor shall construct an asphalt concrete slot twelve inches wide with length that matches the length of the new driveway approach. New driveway approach finish shall match existing finish and shall maintain water flow through the flowline. Adjustment of any existing pipe openings, removal of existing pavement and base/subgrade, and the installation of the AC slot patch shall be included in the contract bid price. Limits of construction shall be verified, measured, and marked in the field by the Engineer prior to removing existing improvements.

Portland cement concrete material shall be Portland Cement Concrete of Type 520-C-2500. Slot Patch should be Type C2 PG 64-10. CMB shall be per Section 200-2.2 of Greenbook but with the following modifications to Table 200-2.2.2:

- 3/4” Sieve (19.0 mm) shall have 100 percentage passing sieve
- 3/8” Sieve (19.0 mm) shall have 50-90 percentage passing sieve.

The Contractor shall replace and repair any irrigation system damaged by his operation in all locations. In some locations, there may be tree roots that need to be removed for proper construction of the improvements. In these cases, the Contractor, at his own expenses, shall cut, remove, and properly dispose the roots per Engineer instructions and per all applicable laws, rules

and regulations. All work necessary to remove and properly dispose of all removed material shall be at no extra cost to the CITY.

Payment for root pruning within the limits of the driveway approach shall be included in the contract bid price.

These pruning guidelines shall be followed by all persons or firms repairing or replacing damaged street, curbs, sidewalks, driveways, or access ramps where the damage is attributable to the roots of the trees growing in the public right-of-way. At least two (2) days prior to any digging or excavating, DigAlert and the Parks Department at 562-383-4170, must be notified.

The Contractor shall remove the concrete at all tree root locations and notify the Parks Department forty-eight (48) hours in advance prior to performing root pruning or selective root removal.

One of the following methods or a combination of methods shall be used when pruning or root removal of tree roots:

Whenever possible, root pruning should only be performed on one side of a tree at a time, meaning on the sidewalk side or street side, but not on both, unless specifically authorized by the City Arborist.

- a. Root Pruning: The actual pruning of roots should be done using a trenching machine, which operates in a vertical motion only, with a root pruning attachment or some comparable piece of equipment, which can safely cut a narrow trench four (4) to six (6) inches wide.
- b. Selective Root Removal: Root larger than three (3) inches in diameter shall be horizontally trimmed or selectively removed. The utilization of a chain saw or other sawing tool shall be employed during this procedure. This procedure shall be overseen by the City Arborist.

All tree activity shall be conducted in a manner specified by ANSI Z133.1 – 2006 Safety Requirements & ANSI A300 (Part 1)-2001 Standard Practices (Pruning).

If the report from the City Arborist recommends the tree be removed because necessary root pruning would be detrimental to the structural integrity of the tree, the Contractor will coordinate with the CITY for removal by CITY resources.

The CITY reserves the right to delete any item or items of the Exhibit A - Bid Schedule and to increase or decrease any quantities in the Bid Schedule as the Engineer directs in exclusion of the Standard Specification for Public Works Construction “the Green Book”. This exclusion shall include, but not be limited to, “Section 3 – Changes In Work” of the Green Book. The twenty-five percent (25%) Green Book rule on quantities of total arithmetic dollar value shall not apply to this project. Unit prices shall continue to apply to the increased or decreased quantities for more and less than twenty-five percent (25%).

No open excavations will be allowed over a weekend or holiday. The Contractor shall schedule work to accommodate this requirement. All concrete must be in place and forms removed prior to weekends and holidays.

Payment for curb and gutter within the limits of the driveway approach shall be included in the contract bid price.

Full compensation for conforming to the requirements in this article SAWCUT AND REMOVE EXISTING DRIVEWAY APPROACH. CONSTRUCT NEW PCC DRIVEWAY APPROACH PER SPPWC 110-2 TYPE B. (BID ITEM 13), shall be considered as included in the contract bid price per Square Foot (SF), and shall include all labor, tools, materials and appurtenances necessary to complete the work and no additional compensation will be allowed therefor.

ARTICLE 12.14: BID ITEM 14, SAWCUT AND REMOVE EXISTING SIDEWALK. CONSTRUCT NEW 4" THICK PCC SIDEWALK OVER 4" CMB AS NEEDED: This bid item shall include all labor, materials, equipment, and work necessary to remove existing and construct new 4" concrete sidewalk over native, if 4" CMB needed it will be paid per Bid Item 8. The Contractor shall saw-cut; excavate and remove existing in-place materials as necessary and properly dispose of material, subgrade, and concrete for new construction; compact subgrade; and construct new 4" sidewalk. New sidewalk finish shall match existing type. Limits of construction shall be verified, measured, and marked in the field by the Engineer prior to removing existing improvements. Adjustment of any existing pipe crossings, and/or irrigation shall be included in the contract bid price.

Portland cement concrete material shall be Portland Cement Concrete of Type 520-C-2500.

The Contractor shall replace and repair any irrigation system damaged by his operation in all locations. In some locations, there may be tree roots that need to be removed for proper construction of the improvements. In these cases, the Contractor, at his own expenses, shall cut, remove, and properly dispose of the roots per Engineer instructions and per all applicable laws, rules and regulations. All work necessary to remove and properly dispose of all removed material shall be at no extra cost to the CITY.

Payment for root pruning within the limits of the curb and gutter shall be included in the contract bid price.

These pruning guidelines shall be followed by all persons or firms repairing or replacing damaged street, curbs, sidewalks, driveways, or access ramps where the damage is attributable to the roots of the trees growing in the public right-of-way. At least two (2) days prior to any digging or excavating, DigAlert and the Parks Department at 562-383-4170, must be notified.

The Contractor shall remove the concrete at all tree root locations and notify the Parks Department forty-eight (48) hours in advance prior to performing root pruning or selective root removal.

One of the following methods or a combination of methods shall be used when pruning or root removal of tree roots:

Whenever possible, root pruning should only be performed on one side of a tree at a time, meaning on the sidewalk side or street side, but not on both, unless specifically authorized by the City Arborist.

- e. Root Pruning: The actual pruning of roots should be done using a trenching machine, which operates in a vertical motion only, with a root pruning attachment or some comparable piece of equipment, which can safely cut a narrow trench four (4) to six (6) inches wide.
- f. Selective Root Removal: Root larger than three (3) inches in diameter shall be horizontally trimmed or selectively removed. The utilization of a chain saw, or other sawing tool shall be employed during this procedure. This procedure shall be overseen by the City Arborist.

All tree activity shall be conducted in a manner specified by ANSI Z133.1 – 2006 Safety Requirements & ANSI A300 (Part 1)-2001 Standard Practices (Pruning).

If the report from the City Arborist recommends the tree be removed because necessary root pruning would be detrimental to the structural integrity of the tree, the Contractor will coordinate with the CITY for removal by CITY resources.

The Contractor shall paint the address of any house that is on a replaced curb with no extra cost to CITY to the satisfaction of the Engineer.

The CITY reserves the right to delete any item or items of the Exhibit A - Bid Schedule and to increase or decrease any quantities in the Bid Schedule as the Engineer directs in exclusion of the Standard Specification for Public Works Construction “the Green Book”. This exclusion shall include, but not be limited to, “Section 3 – Changes In Work” of the Green Book. The twenty-five percent (25%) Green Book rule on quantities of total arithmetic dollar value shall not apply to this project. Unit prices shall continue to apply to the increased or decreased quantities for more and less than twenty-five percent (25%).

No open excavations will be allowed over a weekend or holiday. The Contractor shall schedule work to accommodate this requirement. All concrete must be in place and forms removed prior to weekends and holidays.

Full compensation for conforming to the requirements in this article SAWCUT AND REMOVE EXISTING SIDEWALK. CONSTRUCT NEW 4” THICK PCC SIDEWALK OVER 4” CMB AS NEEDED. (BID ITEM 14), shall be considered as included in the contract bid price per Square Foot (SF), and shall include all labor, tools, materials, CMB and appurtenances necessary to complete the work and no additional compensation will be allowed therefor.

ARTICLE 12.15: BID ITEM 15, FURNISH AND INSTALL TRAFFIC SIGNING, THERMOPLASTIC PAVEMENT MARKINGS AND STRIPING.: This bid item shall include all labor, tools, materials and appurtenances necessary to install traffic striping,

crosswalks, curb painting, curb addresses throughout the project area, markings, raised pavement markers and signs per the plans. The Contractor shall document all existing striping and pavement markings, curb paint, curb addresses, and raised pavement markers for areas which will be removed during construction. Contractor shall lay out and install new striping and markings to replace existing striping and markings, including painted curb and curb addresses where such have been removed due to construction, and raised pavement markers, including the installation of blue reflective raised pavement markers at all fire hydrant locations.

The materials for traffic paint shall be Thermoplastic conforming to the Caltrans Standard Specifications (latest edition), Section 84-2, and the applicable provisions of the Standard Specifications for Public Works Construction "Greenbook" (latest edition). Raised pavement markers shall conform to the Caltrans Standard Specifications (latest edition), Section 85, and the Caltrans Standard Plans (latest edition).

Striping and Markings shall be (Thermoplastic with reflective beads), unless otherwise shown, and shall be placed per Caltrans Standard Specification Section 84: Traffic Stripes and Pavement Markings. Paint, beads, and raised pavement markers shall be approved by the Engineer. The work shall include surface preparation, layout, material placement, curing, protection, testing, traffic control and all other work necessary to install the striping and markings, curb paint and addresses, and raised pavement markers.

Glass beads shall be applied to pavement markings, crosswalks, and striping by a dispensing device developed for this purpose or other methods approved by the Engineer. Streets and surrounding areas are to be kept clean of excess beads.

The Contractor shall furnish the necessary control points for replacement of all striping and markings and shall be responsible for the completeness and accuracy thereof to the satisfaction of the Engineer. No striping or markings shall be installed until the layout has been specifically approved by the Engineer.

Spotting shall be completed prior to the installation of any striping and markings. Striping not removed by grinding operation and shown on plans for striping shall be removed by wet sand blasting method. All markings will be re-striped in thermoplastic shall be removed by wet-sand blasting. Slow School Xing legends on Russell St shall be removed by wet-sand blasting and shall be included in the lump sum price.

All items shown on signing and striping are considered included in this bid item.

All new signs shall be Diamond Grade with anti-graffiti coating on a new 2" Telspar post with FHWA approved breakaway base.

After completion of paving, the Contractor shall install two-way blue raised reflectors on the pavement two (2) feet from centerline of the street (hydrant side) aligned with each fire hydrant location per City requirements.

Full compensation for conforming to the requirements in this article FURNISH AND INSTALL THERMOPLASTIC PAVEMENT MARKINGS AND TRAFFIC STRIPING. (BID ITEM 15), shall be considered as included in the contract bid price per Lump Sum (LS), and shall include all labor, tools, materials and appurtenances necessary to complete the work and no additional compensation will be allowed therefor.

ARTICLE 12.16 & 12.17: BID ITEM 16 & 17, INSTALL 6-FOOT DIAMETER TYPE E, & F TRAFFIC LOOPS: This bid item shall include all labor, tools, materials, and appurtenances necessary to install traffic signal loop detectors. The Contractor shall install Type E, & F loops, as shown per plan and in accordance with Section 86 and 87 of the Standard Specifications and Caltrans Standard Plan No. ES-5A and ES-5B, except as modified or supplemented herein. Loop detectors shall have a 6' diameter. Head loops shall be bicycle compatible Type F in the bike lane .

Loop detector sealant shall consist of hot melt rubber asphalt sealant, in accordance with 86-1.02W, "Loop Detector Sealants," and 87-1.03V, "Detectors," of the Caltrans Standard Specifications.

Existing loop leads shall be disconnected at the termination pull boxes prior to construction operations. New loop detectors shall be spliced to existing DLC's.

Maintain Traffic Signals

Existing traffic signals or approved temporary replacements shall be kept in effective operation for the benefit of the traveling public during the process of the work, except when shutdown is permitted, to allow for alterations of the system. The traffic signal shutdowns shall be limited to normal working hours or shall be as specified in the Special Provisions. The Contractor shall notify the Engineer prior to performing any work on existing systems.

The Contractor shall notify the Engineer and local traffic enforcement agency prior to any operational shutdown of a traffic signal.

All installation and maintenance of temporary traffic signals shall be the responsibility of the Contractor, and furnished and installed as required to maintain safe and acceptable traffic conditions.

NO ADDITIONAL COMPENSATION WILL BE ALLOWED FOR ADDITIONAL MOVE-INS REQUIRED TO CONFORM WITH PHASING SEQUENCING.

No additional compensation will be allowed for removal of concrete containing reinforcing or other steel.

Full compensation for conforming to the requirements in this article INSTALL 6-FOOT DIAMETER TYPE E and F TRAFFIC LOOPS. (BID ITEMS 16-17), shall be considered as included in the contract bid price per Each (EA), and shall include, but not be limited to, full compensation for obtaining required permits with fees, phasing, temporary traffic signals, removals, replacements and pavement restoration, all labor, tools, materials and appurtenances necessary to complete the work and no additional compensation will be allowed therefor.

ARTICLE 12.18: BID ITEM 18, ADJUST MANHOLE TO GRADE: This bid item shall include all labor, tools, materials, and appurtenances necessary to adjust sewer, storm drain, and water manhole covers and vault covers to grade per City of La Habra Standard Detail R-19. The work shall include, but not be limited to, saw-cut, excavation, removal and proper disposal of removed material, as well as protection, removal or lowering of the utility structure during demolition and preparation, setting the structure to grade, and forming pavement or other constructed work around the structure. The work may include replacement with a new structure or cover to be provided by others. The finished adjustment shall be flush to adjacent surfaces and of sufficient strength to support anticipated traffic. All utility adjustment work and safety requirements shall be coordinated with the appropriate utility agency. Additional adjustments shall be necessary to keep the valve lid level with the surrounding pavement as the pavement is lowered and raised during the construction process. At no additional cost to City, the contractor shall coordinate with other utilities as noted on plan for adjustments of their utilities.

The bid item may be increased or reduced at the discretion of the City. The provisions of Section 2-7.1 of the Greenbook governing increases or decreases in quantity of more than 25% shall not apply to this item. Unit prices shall continue to apply to the increased or decreased quantities for more and less than twenty-five percent (25%).

Full compensation for conforming to the requirements in this article ADJUST MANHOLE TO GRADE (BID ITEM 18), shall be considered as included in the contract bid price per Each (EA), and shall include all labor, tools, materials and appurtenances necessary to complete the work and no additional compensation will be allowed therefor.

ARTICLE 12.19: BID ITEM 19, INSTALL AC CURB PER SPPWC 120-3 D1-8

This item in the bid price per Linear Foot includes all labor, tools, materials and appurtenances necessary to install the Asphalt Concrete Curb per Typical Sections as shown on the plans, and shall conform to the following:

Asphalt Concrete Curb shall conform to section 203 of the Standard Specifications (newest edition).

Full compensation for conforming to the requirement in this article INSTALL AC CURB PER SPPWC 120-3 D1-8. (BID ITEM 19), shall be included in the contract unit price bid per linear foot (LF). The unit price shall include all surface preparation, labor, tools, equipment, materials, and incidentals required to complete the work. No additional compensation will be allowed.

ARTICLE 12.20: BID ITEM 20, WHITTIER UNCLASSIFIED EXCAVATION AND DISPOSAL. LOCAL DIGOUTS. REMOVE EXISTING TO 12" & 6"- 4" DEPTHS, SCARIFY, COMPACT BASE AND REGRADE.: This bid item shall include all labor, tools, materials and appurtenances necessary to complete the work necessary as part of this

article which shall include, but not be limited to, sawcut, remove existing roadway structural asphalt concrete pavement, base aggregate, landscaping improvements and/or subgrade soils as necessary to prepare for placement of AC pavement per plans.

The removal of pumping soil, if encountered, shall also be included in roadway excavation. Limits of additional removals due to pumping soil shall be specified by the Engineer.

Excavation, grading and backfill shall be done in conformance with the applicable portion of Section 300 "Earthwork" of the Standard Specifications and shall include any necessary excavation, and/or fill within the right-of-way, including imported material grading of area to finish subgrade ready for improvements, as shown on the plans or as directed by the Engineer.

The Contractor shall comply with Section 300-2.6, "Surplus Material", and shall furnish written consent from the owner of the property where it is intended to dispose of the surplus material.

When the exposed subgrade within 1.0 foot of the grading plane has a relative compaction of less than ninety percent (90%), the subgrade shall be scarified and recompactd in accordance with the provisions of the Standard Specifications and the relative compaction shall not be less than ninety percent (90%). All aggregate base material shall be compacted to 95 percent (95%) of relative maximum density. Tests for the compliance may be made by a representative of the CITY, at the expense of the CITY, using Test Method No. California 231. In the event the initial test fails, additional tests shall be made at the Contractor's expense.

Backfill material and placement shall conform to the applicable portions of Section 300 of the Standard Specifications.

Full compensation for conforming to the requirements in this article ROADWAY EXCAVATION UNCLASSIFIED EXCAVATION AND DISPOSAL. LOCAL DIGOUTS. REMOVE EXISTING TO 12" & 6" - 4" DEPTHS, SCARIFY, COMPACT BASE AND REGRADE. (BID ITEM 20), shall be considered as included in the contract bid price per Cubic Yard (CY) measured volumetrically, and shall include all labor, tools, materials and appurtenances necessary to complete the work and no additional compensation will be allowed therefor.

ARTICLE 12.21: BID ITEM 21, WHITTIER PLACE 6" CMB FINE GRADE, SCARIFY AND COMPACT BASE.

Work under this item shall include all labor, materials, equipment and incidentals required for AC preparation, installation of Tack coat, compaction and protection of work, and all other work associated with this task, complete and in place. The Contractor shall furnish to the Engineer at the time of delivery of the material on the job site a legible copy of a licensed weighmaster's certification showing gross, tare and net weights of each truckload of asphalt concrete mixture. Material that is delivered but not placed within the allotted bid item will not be measured or paid for. This work item shall include all surface preparation and weed abatement as well as labor, materials and work required to fully complete the noted item of work. Measurement and payment for work under this item shall be at the

contract unit price per TON, as measured from the delivered material tickets for material actually installed.

Full compensation for conforming to the requirement in this article WHITTIER PLACE 6" CMB FINE GRADE, SCARIFY AND COMPACT BASE (BID ITEM 21), shall be included in the contract unit price bid per ton (TON), based upon **certified weigh master tickets**. The unit price shall include all surface preparation, tack coat, rock dust blotter, labor, tools, equipment, materials, and incidentals required to complete the work. No additional compensation will be allowed.

ARTICLE 12.22: BID ITEM 22, WHITTIER INSTALL 4" THICK ASPHALT CONCRETE BASE COURSE (B PG 64-10)

This item in the bid price per Tons includes all labor, tools, materials and appurtenances necessary to lay the Asphalt Concrete Base Course as follows:

Asphalt concrete base course shall be Paving Asphalt, Type B PG 64-10, conforming to Section 203-1 as specified in Section 203.10.2.1 of the Standard Specifications (latest edition) per Typical Sections as shown on the plans, and shall conform to the following:

The Contractor shall submit a copy of the asphalt concrete mix design to the City or its designated laboratory a minimum of two weeks prior to the start of the construction.

Apply SS-1H tack coat at a rate not to exceed one-tenth (1/10) gallon per square yard uniformly in one coat on all vertical joints of AC patching and P.C.C. surfaces and edges against which Pavement Asphalt is to be placed. Diesel fuel shall not be used for cleaning purposes within the limits of this project.

B PG 64-10 shall be thoroughly compacted by rolling. The number of rollers necessary will be established in accordance with Section 302-5.6.1 of the Greenbook Specifications. All compacted B PG 64-10 shall have a relative compaction of not less than 95 percent in accordance with Section 302-5.6.2 of the Greenbook Specifications.

Rock dust blotter material shall be required immediately after the completion of the "finish rolling" and prior to opening to traffic to prevent bleeding and tracking of the asphalt material.

Rock dust blotter shall be per Section 200-1.2 of the Standard Specifications and shall be uniformly applied using a mechanical spreader, which distributes uniformly at a rate of approximately three pounds per square yard. Compaction rollers shall not be allowed on the rock dust covered pavement surfaces. All excess rock dust blotter shall be removed from the street at the end of each workday.

Full compensation for conforming to the requirement in this article WHITTIER INSTALL 4" THICK ASPHALT CONCRETE BASE COURSE (B PG 64-10). **(BID ITEM 22)**, shall be included in the contract unit price bid per ton (TON), based upon **certified weigh master tickets**.

The unit price shall include all surface preparation, tack coat, rock dust blotter, labor, tools, equipment, materials, and incidentals required to complete the work. No additional compensation will be allowed.

ARTICLE 12.23: BID ITEM 23, WHITTIER INSTALL 2" THICK ASPHALT RUBBER HOT MIX (ARHM-GG-C PG 64-16) OVERLAY.

This item in the bid price per Tons includes all labor, tools, materials and appurtenances necessary to lay the Rubberized Asphalt as follows:

Asphalt concrete surface course shall be Asphalt Rubber Hot Mix, Type ARHM-GG-C, wet process, as specified in Section 203-11 and 302-9 of the Standard Specifications (latest edition), per Typical Sections as shown on the plans, and shall conform to the following:

Paving asphalt used for asphalt-rubber shall be performance grade PG 64-16. Composition and Grading shall be per Section 203-11.3 of the Standard Specifications (latest edition). The Contractor shall submit a copy of the asphalt concrete mix design to the City or its designated laboratory a minimum of two weeks prior to the start of the construction.

The Contractor shall place the ARHM a maximum of 48 hours after the commencement of all full width grinding operations during any stage of the work for this project.

Apply SS-1H tack coat at a rate not to exceed one-tenth (1/10) gallon per square yard uniformly in one coat on all vertical joints of AC patching and P.C.C. surfaces and edges against which ARHM is to be placed. Diesel fuel shall not be used for cleaning purposes within the limits of this project.

All surfaces to be overlaid shall be cleaned by the use of a broom and a vacuum sweeper. The overlaid surface shall be free of water, dust, or foreign material before tack is applied. All raised pavement markers shall be removed prior to the placement of any AHRM concrete overlay. Removal of all AC slurry seal residue from gutter lip should be completed prior to paving.

The Contractor shall utilize a paving machine equipped with an automatic adjusting screed, which is actuated by a 30-foot "ski", for the entire ARHM-GG-C overlay.

ARHM-GG-C shall be thoroughly compacted by rolling. The number of rollers necessary will be established in accordance with Section 302-5.6.1 of the Greenbook Specifications. All compacted ARHM-GG-C shall have a relative compaction of not less than 95 percent in accordance with Section 302-5.6.2 of the Greenbook Specifications.

Rolling along a joint shall be such that the widest part of the roller is on the hot side of the joint. Join lines between successive runs shall be within 5 inches of lane lines or a minimum of 12 feet outside of the outermost lane line.

The Contractor shall provide for adequate quality control measures to ensure that delivery of asphalt rubber shall be neither too slow nor too fast to prevent stopping of the paving operation and/or cooling of the asphalt rubber material. Material delivery scheduling and handling is critical to provide for optimum compaction opportunity and maximize ride quality performance.

Rock dust blotter material shall be required immediately after the completion of the “finish rolling” and prior to opening to traffic to prevent bleeding and tracking of the asphalt rubber material.

Rock dust blotter shall be per Section 200-1.2 of the Standard Specifications and shall be uniformly applied using a mechanical spreader, which distributes uniformly at a rate of approximately three pounds per square yard. Compaction rollers shall not be allowed on the rock dust covered pavement surfaces. All excess rock dust blotter shall be removed from the street at the end of each workday.

Full compensation for conforming to the requirement in this article INSTALL 2" THICK ASPHALT RUBBER HOT MIX (ARHM-GG-C PG 64-16) OVERLAY. (BID ITEM 23), shall be included in the contract unit price bid per ton (TON), based upon **certified weigh master tickets**. The unit price shall include all surface preparation, tack coat, rock dust blotter, labor, tools, equipment, materials, and incidentals required to complete the work. No additional compensation will be allowed.

SECTION D
PROPOSAL

PROPOSAL

City of La Habra
Civic Center
110 E. La Habra Blvd.
La Habra, California 90631

Gentlemen:

The undersigned hereby proposes to perform all work for which a contract may be awarded him and to furnish any and all plant, labor, services, materials, tools, equipment, supplies, transportation, utilities, and all other items and facilities necessary therefor as provided in the Contract Documents, and to do everything required therein for the project specifically set forth in documents entitled:

**MACY STREET REHABILITATION PROJECT
CITY PROJECT NO. 1-R-23**

together with appurtenances thereto, all as set forth on the drawing and in the specifications and other Contract Documents; and, he further proposes and agrees that if this Proposal is accepted he will contract in the form and manner stipulated to perform all the work called for by drawings, specifications and other Contract Documents and to complete all such work in strict conformity therewith within the time limits set forth therein, and that he will accept as full payment therefor the prices set forth in the Bid Schedule forming a part hereof.

A *(Cashier’s Check) *(Certified Check) *(Bid Bond) properly made payable to City of La Habra hereinafter designated as the Owner for the sum of _____

dollars (\$ _____), which amount is not less than ten percent (10%) of the total amount of this bid, is attached hereto and is given as a guarantee that the undersigned will execute the Agreement and furnish the required bonds if awarded the Contract; and, in case of failure to do so within the time provided the proceeds of said check shall be forfeited to the *Owner/Sureties Liability to the Owner for forfeiture of the face amount of the Bond shall be considered as established.

(*) Delete inapplicable word or phrase.

It is understood and agreed that:

1. The undersigned has carefully examined all the Contract Documents which will form a part of the Contract;
2. The undersigned has, by investigation of the site of the work and otherwise, satisfied himself as to the nature and location of the work and has fully informed himself as to all conditions and matters which can in any way affect the work or the cost thereof;
3. The undersigned fully understands the scope of the work and has checked carefully all words and figures inserted in this proposal and he further understands that the Owner will in no way be responsible for any errors or omissions in the preparation of this proposal;
4. The undersigned will execute the Agreement and furnish the required Performance and Payment Bonds and proof of insurance coverage, within ten (10) days (not

including Saturdays, Sundays and holidays) after notice to him of acceptance of his bid by the Owner; and further, that this bid may not be withdrawn for a period of sixty (60) days after the date set for the opening thereof, unless otherwise required by law. If any bidder shall withdraw his bid within said period, the Contractor shall be liable under the provisions of the Bid Security or the Contract and his surety shall be liable under the Bid Bond, as the case may be;

5. The undersigned hereby certifies that this proposal is genuine and not sham or collusive or made in the interest or in behalf of any person not herein named and the undersigned has not directly or indirectly induced or solicited any other bidder to put in a sham bid or any other person, firm or corporation to refrain from bidding; the undersigned has not in any manner sought by collusion to secure for himself an advantage over any other bidder;
6. In conformance with current statutory requirements of Section 1860, et seq., of the Labor Code of the State of California, the undersigned confirms the following as his certification:

I am aware of the provisions of Section 3700 of the Labor Code which requires every employer to be insured against liability of worker's compensation or to undertake in accordance with the provisions before commencing the performance of the work of this contract.

NOW, in compliance with the Notice Inviting Bids and all the provisions hereinbefore stipulated, the undersigned, with full cognizance thereof, hereby proposes to perform the entire work for the prices set forth in the attached Bid Schedule upon which award of the Contract is made.

Date: _____, 2025

Bidder _____

By _____

Title _____

Bidder's Post Office Address:

Corporation organized under
the laws of the State of _____

Names and addresses of all owners
of the firm or names and titles of
all officers of the corporation:

(corporate seal)

BIDDER'S INFORMATION

Contractor's License No. _____ Expiration Date _____

Classification of Contractor's License No. _____

Contractor _____
(name of firm)

By _____
(signature) (title)

Business Address: _____

Phone () _____

I/We certify that the information provided above is complete and true to the best of my/our knowledge.

Contractor Date

Contractor's DIR Public Works Registration No. _____

EXHIBIT A
BID SCHEDULE

MACY STREET REHABILITATION PROJECT
CITY PROJECT NO. 1-R-23

ITEM	DESCRIPTION	QUANTITY	UNIT	UNIT PRICE	AMOUNT
1	MOBILIZATION, DEMOBILIZATION, & CLEANUP (Not to Exceed Five Percent (5%) of the total bid amount)	1	LS		
2	TRAFFIC CONTROL AND PUBLIC NOTIFICATION (Not to Exceed Five Percent (5%) of the total bid amount)	1	LS		
3	CONSTRUCTION SURVEYING AND MONUMENT PRESERVATION.	1	LS		
4	STORM WATER BEST MANAGEMENT PRACTICES (BMPs)	1	LS		
5	COLD MILL EXISTING AC PAVEMENT TO 2" DEPTH	99,500	SF		
6	UNCLASSIFIED EXCAVATION AND DISPOSAL. LOCAL DIGOUTS. REMOVE EXISTING 12" DEPTH, SCARIFY, COMPACT BASE AND REGRADE.	70	CY		
7	CONSTRUCT HEADER BOARD WITH STAKES	155	LF		
8	PLACE 6" CMB FINE GRADE, SCARIFY AND COMPACT BASE.	70	TON		
9	INSTALL 4" THICK ASPHALT CONCRETE BASE COURSE (B PG 64-10)	50	TON		
10	INSTALL 2" THICK ASPHALT RUBBER HOT MIX (ARHM-GG-C PG 64-16) OVERLAY.	1,300	TON		
11	INSTALL PCC CURB AND GUTTER PER SPPWC 120-3 A2-8	250	LF		

12	REMOVE EXISTING & CONSTRUCT NEW ADA COMPLIANT CURB RAMP PER PLANS.	1	EA		
13	SAWCUT AND REMOVE EXISTING DRIVEWAY APPROACH. CONSTRUCT NEW PCC DRIVEWAY APPROACH PER SPPWC 110-2 TYPE B.	90	SF		
14	SAWCUT AND REMOVE EXISTING SIDEWALK. CONSTRUCT NEW 4" THICK PCC SIDEWALK OVER 4" CMB AS NEEDED.	360	SF		
15	FURNISH AND INSTALL TRAFFIC SIGNING, THERMOPLASTIC PAVEMENT MARKINGS AND STRIPING.	1	LS		
16	INSTALL 6-FOOT DIAMETER TYPE E TRAFFIC LOOP	1	EA		
17	INSTALL 6-FOOT DIAMETER TYPE F TRAFFIC LOOP	2	EA		
18	ADJUST MANHOLE FRAME AND COVER TO GRADE	7	EA		
19	REMOVE AND REPLACE AC CURB PER SPPWC 120-3 D1-8	235	LF		
20	WHITTIER UNCLASSIFIED EXCAVATION AND DISPOSAL. LOCAL DIGOUTS. REMOVE EXISTING TO 12" & 6"- 4" DEPTHS, SCARIFY, COMPACT BASE AND REGRADE	52	CY		

21	WHITTIER PLACE 6" CMB FINE GRADE, SCARIFY AND COMPACT BASE.	30	TON		
22	WHITTIER INSTALL 4" THICK ASPHALT CONCRETE BASE COURSE (B PG 64-10)	51	TON		
23	WHITTIER INSTALL 2" THICK ASPHALT RUBBER HOT MIX (ARHM-GG-C PG 64-16) OVERLAY.	38	TON		

TOTAL BID PRICE FOR BID SCHEDULE IN FIGURES: \$_____

TOTAL BID PRICE FOR BID SCHEDULE IN WORDS: _____

Note: All bid quantities are estimated and for bidding purposes only, it may be increased or decreased at the discretion of the CITY. The provisions of Sections 3-2.2.2 and 3-2.2.3 of the Greenbook governing increases or decreases in quantity of more than 25% shall not apply.

Note: The TOTAL BID PRICE shall be used as the basis of bid in determining the low bid for this project.

CONTRACTOR

BY

TITLE

DATE

ACKNOWLEDGEMENT OF ADDENDA RECEIVED

The Bidder shall acknowledge the receipt of addenda by placing an “X” by each addendum received.

- Addendum No. 1 _____
- Addendum No. 2 _____
- Addendum No. 3 _____
- Addendum No. 4 _____
- Addendum No. 5 _____
- Addendum No. 6 _____
- Addendum No. 7 _____
- Addendum No. 8 _____

If an addendum or addenda have been issued by the CITY and is not noted above as being received by the Bidder, the Bid Proposal may be rejected.

REFERENCES

[Work similar in scope magnitude and degree of difficulty completed by Contractor within the past three (3) years.]

1. Name (Firm/Agency): _____
Address: _____
Contact Person: _____ Telephone No. _____
Title of Project: _____
Project Location: _____
Date of Completion: _____ Contract Amount: \$ _____
2. Name (Firm/Agency): _____
Address: _____
Contact Person: _____ Telephone No. _____
Title of Project: _____
Project Location: _____
Date of Completion: _____ Contract Amount: \$ _____
3. Name (Firm/Agency): _____
Address: _____
Contact Person: _____ Telephone No. _____
Title of Project: _____
Project Location: _____
Date of Completion: _____ Contract Amount: \$ _____
4. Name (Firm/Agency): _____
Address: _____
Contact Person: _____ Telephone No. _____
Title of Project: _____
Project Location: _____
Date of Completion: _____ Contract Amount: \$ _____

If Contractor has not performed work for the City of La Habra within the last five (5) years, list all work done within said five years (attach additional sheets if necessary). Note if work was done as subcontractor (include only subcontract amount):

Work Description & Contract Amount	Agency	Date Completed

Contractor's License No.: _____ Class: _____

a. Date first obtained: _____ Expiration: _____

b. Has License ever been suspended or revoked? _____

If yes, described when and why: _____

c. Any current claims against License or Bond? _____

If yes, describe claims: _____

Principals in Company (List all – attach additional sheets if necessary):

<u>NAME</u>	<u>TITLE</u>	<u>LICENSE NO.</u> (If Applicable)
_____	_____	_____
_____	_____	_____
_____	_____	_____

DBE BIDDER'S LIST

All bidders/proposers are requested to provide the following information for all DBE and non-DBE contractors or consultants who provided a proposal, bid, quote, or were contacted by the proposed prime. This information is also requested from the proposed prime contractor/consultant and should be submitted with their bid/proposal. The City of La Habra will use this information to maintain and update a "Bidders" List to assist in the overall annual DBE goal-setting process.

Firm Name: _____	Phone: _____
Address: _____	Fax: _____
Contact Person: _____	No. of years in business: _____
Is the firm currently certified as a DBE under 49 CFR Part 26: YES: ___ NO: ___	
Type of work/services/materials provided by firm? _____	

<hr/> <hr/> What was your firm's Gross Annual receipts for last year?	
Less than \$1 Million	
Less than \$5 Million	
Less than \$10 Million	
Less than \$15 Million	
More than \$15 Million	

This form can be duplicated if necessary to report all bidders (DBEs and non-DBEs) information.

VIOLATIONS OF FEDERAL, STATE, OR LOCAL LAWS

1. Has your firm or its officers been assessed any penalties by an agency for noncompliance or violations of Federal, State, or Local labor laws and/or business or licensing regulations within the past five (5) years relating to your construction projects?

Yes/No: _____ Federal/State: _____

If "yes", identify and describe, (including agency and status):

Have the penalties been paid? Yes/No: _____

2. Does your firm or its officers have any ongoing investigations by any public agency regarding violations of the State Labor Code, California Business and Professions Code or State Licensing Laws?

Yes/No: _____ Code/Laws: _____ Section/Article: _____

If "yes", identify and describe, (including agency and status):

DISQUALIFICATION OR DEBARMENT

Has your firm, any officer of your firm, or any employee who has a proprietary interest in your firm ever been disqualified, removed, or otherwise prevented from bidding on, performing work on, or completing a federal, state, or local project because of a violation of law or a safety regulation?

Yes/No: _____

If yes, provide the following information (if more than once, use separate sheets):

Date: _____ Entity: _____

Location: _____

Reason: _____

Provide Status and any Supplemental Statement: _____

Has your firm been reinstated by this entity?

Yes/No: _____

LIST OF SUBCONTRACTORS

**MACY STREET REHABILITATION PROJECT
CITY PROJECT NO. 1-R2-3**

The bidder shall list below the name and the location of the place of business of each Subcontractor who will perform work or render services to the prime contractor in or about the construction of the work or improvement in excess of one-half of one percent (1/2%) of the prime contractor's total bid or ten thousand dollars (\$10,000.00) whichever is greater in accordance with the requirements of Section 4100 to 4133 inclusive of the public contracts code.

<u>Work to be Performed</u>	<u>License Number</u>	<u>Subcontractor and Address of Office, Mill or Shops</u>	<u>Percent of Total Contract</u>	<u>DBE</u>	
				<u>YES</u>	<u>NO</u>

Note: Do not list alternative subcontractors for the same work.

Contractor _____

BID SECURITY FORM

(Check to Accompany Bid)

(Note: The following form shall be used in case check accompanies bid.)

Accompanying this proposal is a *(Certified) *(Cashiers) check payable to the order of the City of La Habra, California, hereinafter referred to as "Owner", for

**MACY STREET REHABILITATION PROJECT
CITY PROJECT NO. 1-R-23**

In the amount of \$ _____ Dollars, this amount being ten percent (10%) of the total amount of the bid. The proceeds of this check shall become the property of said Owner provided this proposal shall be accepted by the said Owner through action of its legally constituted contracting authorities and the undersigned shall fail to execute a contract and furnish the required Performance and Payment Bonds and proof of insurance coverage within the stipulated time; otherwise, the check shall be returned to the undersigned. The proceeds of this check shall also become the property of the Owner if the undersigned shall withdraw his bid within the period of forty-five (45) days after the date set for the opening thereof unless otherwise required by law and notwithstanding the award of the Contract to another bidder.

Bidder

*Delete the inapplicable word.

NOTE: If the bidder desires to use a bond instead of a check, the Bid Bond form on the following pages shall be executed. The sum of this bond shall be not less than ten percent (10%) of the total amount of the bid.

BID BOND

KNOW ALL MEN BY THESE PRESENTS:

That we _____ as principal and _____ as surety, are held and firmly bound unto the City of La Habra, California hereinafter referred to as "Owner", in the sum of _____ Dollars (§ _____) to be paid to the said Owner, its successors and assigns for which payment well and truly to be made we bind ourselves, our heirs, executors, administrators, successors and assigns, jointly and severally, firmly by these presents.

THE CONDITION OF THIS OBLIGATION IS SUCH that if the certain proposal of the above bounden for the construction of Street Improvements as specifically set forth in documents entitled:

**MACY STREET REHABILITATION PROJECT
CITY PROJECT NO. 1-R-23**

all in accordance with the specifications and drawings on file at the offices of the City Clerk of the City of La Habra, California and is not withdrawn within the period of sixty (60) days after the date set for the opening of bids unless otherwise required by law and notwithstanding the award of the Contract to another bidder and that if said proposal is accepted by the Owner through action of its legally constituted contracting authorities and if the above bounden his heirs, executors, administrators, successors and assigns shall duly enter into and execute a contract for such construction and shall execute and deliver the required Performance and Payment Bonds and proof of insurance coverage within ten (10) days (not including Saturdays, Sundays and Holidays) after the date of notification by and from the said Owner that the said contract is ready for execution, then this obligation shall become null and void; otherwise, it shall be and remain in full force and virtue.

IN WITNESS WHEREOF, we hereunto set hands and seal this _____

day of _____, 2025.

BIDDER

NOTE: The standard printed bond form of any bonding company acceptable to the Owner may be used in lieu of the foregoing approved sample bond form provided the security stipulations protecting the Owner are not in any way reduced by use of the Surety Company's printed standard form.

NON-COLLUSION AFFIDAVIT

FOR

**MACY STREET REHABILITATION PROJECT
CITY PROJECT NO. 1-R-23**

(TO BE EXECUTED BY EACH AWARDEE OF A PRINCIPAL CONTRACT)

STATE OF CALIFORNIA)
) SS.
)

_____, being first duly sworn,
deposes and says that he is _____
(sole owner, partner, president, secretary, etc.)

of _____

The party making the foregoing bid; that such bid is not made in the interest of or on behalf of any undisclosed person, partnership, company, association, organization or corporation; that such bid is genuine and not collusive or sham: that said bidder has not directly or indirectly induced or solicited any other bidder to put in a false or sham bid, and has not directly or indirectly colluded, conspired, connived, or agreed with any bidder or anyone else to put in a sham bid, nor that anyone shall refrain from bidding; that said bidder has not in any manner directly or indirectly sought by agreement, communication or conference with anyone to fix the bid price of said bidder or of any other bidder, nor to fix any overhead, profit cost element of such bid price nor of that of any other bidder nor to secure any advantage against the public body awarding the contract or anyone interested in the proposed contract; that all statements contained in such bid are true; and, further, that said bidder has not directly or indirectly, submitted his bid price or any breakdown thereof, nor the contents thereof, nor divulged information or data relative thereto, nor paid and will not pay any fee in connection therewith to any corporation, partnership, company, association, organization, bid depository, nor to any member of agent thereof nor to any other individual except to such person or persons as have a partnership or other financial interest with said bidder in his general business.

Signed: _____

Title: _____

Subscribed and sworn to before me

This _____ day of _____, 2025

SEAL OF NOTARY PUBLIC

WORKER'S COMPENSATION CERTIFICATE

(AS REQUIRED BY SECTION 1861
OF THE CALIFORNIA LABOR CODE)

I am aware of the provisions of Section 3700 of the California Labor Code, which require every employer to be insured against liability for worker's compensation, or to undertake self-insurance in accordance with the provisions of said Code, and I will comply with such provisions before commencing the performance of the Work of this Contract.

Contractor _____

By _____

Title _____

Public Contract Code Section 10285.1 Statement

In conformance with Public Contract Code Section 10285.1 (Chapter 376, Stats. 1985), the bidder hereby declares under penalty of perjury under the laws of the State of California that the bidder **has** ____, **has not** ____ been convicted within the preceding three years of any offenses referred to in that section, including any charge of fraud, bribery, collusion, conspiracy, or any other act in violation of any state or Federal antitrust law in connection with the bidding upon, award of, or performance of, any public works contract, as defined in Public Contract Code Section 1101, with any public entity, as defined in Public Contract Code Section 1100, including the Regents of the University of California or the Trustees of the California State University. The term "bidder" is understood to include any partner, member, officer, director, responsible managing officer, or responsible managing employee thereof, as referred to in Section 10285.1.

Note: The bidder must place a check mark after "has" or "has not" in one of the blank spaces provided. The above Statement is part of the Proposal. Signing this Proposal on the signature portion thereof shall also constitute signature of this Statement. Bidders are cautioned that making a false certification may subject the certifier to criminal prosecution.

Public Contract Code Section 10162 Questionnaire

In conformance with Public Contract Code Section 10162, the Bidder shall complete, under penalty of perjury, the following questionnaire:

Has the bidder, any officer of the bidder, or any employee of the bidder who has a proprietary interest in the bidder, ever been disqualified, removed, or otherwise prevented from bidding on, or completing a federal, state, or local government project because of a violation of law or a safety regulation?

Yes _____ No _____

If the answer is yes, explain the circumstances in the following space.

Public Contract Code Section 10232 Statement

In conformance with Public Contract Code Section 10232, the Contractor, hereby states under penalty of perjury, that no more than one final unappealable finding of contempt of court by a federal court has been issued against the Contractor within the immediately preceding two year period because of the Contractor's failure to comply with an order of a federal court which orders the Contractor to comply with an order of the National Labor Relations Board.

Note: The above Statement and Questionnaire are part of the Proposal. Signing this Proposal on the signature portion thereof shall also constitute signature of this Statement and Questionnaire.

Bidders are cautioned that making a false certification may subject the certifier to criminal prosecution.

SECTION E
SAMPLE AGREEMENT

**CITY OF LA HABRA
PUBLIC WORKS AGREEMENT FOR
MACY STREET REHABILITATION PROJECT
CITY PROJECT NO. 1-R-23**

THIS AGREEMENT (herein "Agreement"), is made and entered into this _____ day of _____, 2025 and between the **CITY OF LA HABRA**, a municipal corporation (herein "City") and _____ (herein "Contractor"). The parties hereto agree as follows:

WITNESSETH:

A. WHEREAS, City requires the construction of roadway improvements as set forth more fully in this Agreement.

B. WHEREAS, Contractor represents to City that Contractor is qualified to perform said work and has submitted a proposal to City for the same.

C. WHEREAS, City desires to have Contractor perform said services on the terms and conditions set forth herein.

D. WHEREAS, no official or employee of City has a financial interest, within the provisions of Sections 1090-1092 of the California Government Code, in the subject matter of this Agreement.

NOW, THEREFORE, for and in consideration of the mutual covenants and conditions contained herein and for good and valuable consideration, the receipt and sufficiency of which is acknowledged by both parties, City and Contractor hereby agree as follows:

1.0 DEFINITIONS

1.1 Definitions. As used in this Agreement, the following definitions shall be applicable:

- (a) Contractor. Contractor shall mean _____, a California corporation located at _____.
- (b) City. City shall mean the City of La Habra, a Municipal Corporation and General Law City, located at 110 E. La Habra Blvd, La Habra, California 90631.
- (c) City Council. City Council shall mean the City Council of the City of La Habra.
- (d) Contract Officer shall mean the person designated by the City Administrator or City Engineer of City and shall have the duties set forth in Section 5.2.
- (e) Services. Services shall mean the services to be performed by the Contractor pursuant to this Agreement.
- (f) Satisfactory. Satisfactory shall mean satisfactory to the City Administrator or his/her designee.

2.0 SERVICES OF CONTRACTOR

2.1 Scope of Services. In compliance with all terms and conditions of this Agreement, the Contractor shall provide those services specified in the "Scope of Services" attached hereto as Exhibit "A" and incorporated herein by this reference, which services may be referred to herein as the "services" or "work" hereunder. As a material inducement to the City entering into this Agreement, Contractor represents and warrants that Contractor is a provider of first class work and services and Contractor is experienced in performing the work and services contemplated herein and, in light of such status and experience, Contractor covenants that it shall follow the highest professional standards in performing the work and services required hereunder and that all materials will be of good quality, fit for the purpose intended.

2.2 Documents Included in Contract. This contract consists of this Agreement and any Exhibits, which are incorporated herein by this reference. In the event of an inconsistency, the terms of this Agreement shall govern.

2.3 Compliance with Law. All services rendered hereunder shall be provided in accordance with all ordinances, resolutions, statutes, rules, and regulations of the City and any Federal, State or local governmental agency having jurisdiction in effect at the time service is rendered, including but not limited to, the claims procedure set forth in Public Contract Code Section 9204, a summary of which is attached to this agreement as Exhibit "D."

2.4 Licenses, Permits, Fees and Assessments. Contractor shall obtain at its sole cost and expense such licenses, permits and approvals as may be required by law for the performance of the services required by this Agreement, including registration with the Department of Industrial Relations of the State of California as required by Labor Code Section 1725.5 before commencing performance under this Agreement. Contractor shall have the sole obligation to pay for any fees, assessments and taxes, plus applicable penalties and interest, which may be imposed by law and arise from or are necessary for the Contractor's performance of the services required by this Agreement, and shall indemnify, defend and hold harmless City against any such fees, assessments, taxes penalties or interest levied, assessed or imposed against City hereunder. Contractor shall be responsible for all subcontractors' compliance with this Section 2.4.

2.5 Familiarity with Work. By executing this Contract, Contractor warrants that Contractor (a) has thoroughly investigated and considered the scope of services to be performed, (b) has carefully considered how the services should be performed, and (c) fully understands the facilities, difficulties and restrictions attending performance of the services under this Agreement. If the services involve work upon any site, Contractor warrants that Contractor has or will investigate the site and is or will be fully acquainted with the conditions there existing, prior to commencement of services hereunder. Should Contractor discover any latent or unknown conditions, which will materially affect the performance of the services hereunder, Contractor shall immediately inform the City of such fact and shall not proceed except at Contractor's risk until written instructions are received from the Contract Officer.

2.6 Standard of Performance. Contractor, its subcontractors and their employees, in the performance of Contractor's work under this Agreement shall be responsible for exercising the degree of skill and care required by customarily accepted good professional practices and procedures used in the Contractor's field.

Any costs for failure to meet the foregoing standard or to correct otherwise defective work that requires re-performance of the work, shall be borne in total by the Contractor and not by the City. The failure of a

project to achieve the performance goals and objectives stated in this Agreement is not a basis for requesting re-performance unless the work conducted by Contractor and/or its subcontractors is deemed by the City to have failed the foregoing standard of performance.

In the event Contractor fails to perform in accordance with the above standard:

1. Contractor will re-perform, at its own expense, any task which was not performed to the reasonable satisfaction of City. Any work re-performed pursuant to this paragraph shall be completed within the time limitations originally set forth for the specific task involved. Contractor shall work any overtime required to meet the deadline for the task at no additional cost to the City;
2. The City shall provide a new schedule for the re-performance of any task pursuant to this paragraph in the event that re-performance of a task within the original time limitations is not feasible; and
3. The City shall have the option to direct Contractor not to re-perform any task which was not performed to the reasonable satisfaction of the City Project Manager pursuant to application of (1) and (2) above. In the event the City directs Contractor not to re-perform a task, the City shall negotiate a reasonable settlement for satisfactory work performed. No previous payment shall be considered a waiver of the City's right to reimbursement.

Nothing contained in this section is intended to limit any of the rights or remedies which the City may have under law.

2.7 Care of Work. The Contractor shall adopt reasonable methods during the life of the Agreement to furnish continuous protection to the work, and the equipment, materials, papers, documents, plans, studies and/or other components thereof to prevent losses or damages, and shall be responsible for all such damages, to persons or property, until acceptance of the work by City, except such losses or damages as may be caused by City's own negligence.

2.8 Further Responsibilities of Parties. Both parties agree to use reasonable care and diligence to perform their respective obligations under this Agreement. Both parties agree to act in good faith to execute all instruments, prepare all documents and take all actions as may be reasonably necessary to carry out the purposes of this Agreement. Unless hereafter specified, neither party shall be responsible for the service of the other. Contractor shall require all subcontractors to comply with the provisions of this agreement.

2.9 Additional Services. City shall have the right at any time during the performance of the services, without invalidating this Agreement, to order extra work beyond that specified in the Scope of Services or make changes by altering, adding to or deducting from said work. No such extra work may be undertaken unless a written change order is first given by the Contract Officer to the Contractor, incorporating therein any adjustment in (i) the Contract Sum as set forth in Section 3.1, and/or (ii) the time to perform this Agreement, which said adjustments are subject to the written approval of the Contractor. Any increase in compensation of twenty five percent (25%) or less of the Contract Sum, or in the time to perform of one hundred eighty (180) days or less may be approved by the Contract Officer. Any increases, taken either separately or cumulatively, that result in the Contract Sum exceeding \$25,000 must be approved by the City Council. It is expressly understood by Contractor that the provisions of this Section shall not apply to services specifically set forth in the Scope of Services or reasonably contemplated therein. Contractor hereby acknowledges that it accepts the risk that the services to be provided pursuant to the Scope of Services may be more costly or time consuming than Contractor anticipates and that Contractor shall not be entitled to additional compensation therefore.

2.10 Prevailing Wage Laws. Contractor represents and warrants that it is registered with the Department of Industrial Relations pursuant to SB 854 and Labor Code 1725.5. Contractor shall ensure that its subcontractors comply with said requirements. In accordance with Labor Code Section 1770 et seq., the Director of the Department of Industrial Relations of the State of California has ascertained a general prevailing rate of wages, which is the minimum amount, which shall be paid to all workers employed to perform the work pursuant to this Agreement. A copy of the general prevailing wage rate determination is on file in the Office of the City Clerk and is hereby incorporated by reference into this Agreement. In accordance with the provisions of Labor Code Section 1810 et seq., eight (8) hours is the legal working day. Contractor must forfeit to the City Twenty Five Dollars (\$25.00) a day for each worker who works in excess of the minimum working hours when Contractor does not pay overtime. Contractor is required to post a copy of such wage rates at all times at the contract site. The statutory penalties for failure to pay prevailing wage or to comply with State wage and hour laws will be enforced. Contractor also shall comply with State law requirements to maintain payroll records and shall provide for certified records and inspection of records as required by California Labor Code Section 1770 et. seq., including Section 1776. Contractor shall comply with all statutory requirements relating to the employment of apprentices.

3.0 COMPENSATION

3.1 Contract Sum. For the services rendered pursuant to this Agreement, the Contractor shall be compensated as specified herein, but not exceeding the maximum contract amount of ____ Dollars (\$____) (herein "Contract Sum"), except as provided in Section 2.9. The Contract Sum shall include the attendance of Contractor at all project meetings reasonably deemed necessary by the City; Contractor shall not be entitled to any additional compensation for attending said meetings.

3.2 Progress Payments. Prior to the first day of the month, during the progress of the work, commencing on the day and month specified in the Agreement, Contractor shall submit to the Contract Officer a complete itemized statement of all labor and materials incorporated into the work during the preceding month and the portion of the contract sum applicable thereto. Upon approval in writing by the Contract Officer, payment shall be made in thirty (30) days. City shall pay Contractor a sum based upon ninety-five percent (95%) of the contract price apportionment of the labor and materials incorporated into the work under the contract during the month covered by said statement. The remaining five percent (5%) thereof shall be retained as performance security. Refer to Section 8.4 of this Agreement for retention of funds.

4.0 PERFORMANCE SCHEDULE

4.1 Time of Essence. Time is of the essence in the performance of this Agreement.

4.2 Schedule of Performance. Contractor shall commence the services pursuant to this Agreement upon receipt of a written notice to proceed and shall perform all services within the time period(s) established in Exhibit "A", and incorporated herein by this reference. When requested by the Contractor, extensions to the time period(s) specified in the Scope of Services may be approved in writing by the Contract Officer.

4.3 Force Majeure. The time period(s) specified in the Scope of Services for performance of the services rendered pursuant to this Agreement shall be extended because of any delays due to unforeseeable causes beyond the control and without the fault or negligence of the Contractor, including, but not restricted to, acts of God or of the public enemy, unusually severe weather, fires, earthquakes, floods, epidemics, quarantine restrictions, riots, strikes, freight embargoes, wars, litigation, and/or acts of any governmental agency, including the City, if the Contractor shall within ten (10) days of the commencement of such delay notify the Contract

Officer in writing of the causes for the delay. The Contract Officer shall ascertain the facts and the extent of delay, and extend the time for performing the services for the period of the enforced delay when and if in the judgment of the Contract Officer such delay is justified. The Contract Officer's determination shall be final and conclusive upon the parties to this Agreement.

4.4 Term. Unless earlier terminated in accordance with Section 8.9 of this Agreement, this Agreement shall continue in full force and effect until final approval and acceptance of the project by the Contract Officer. Notwithstanding the foregoing, this Agreement shall terminate no later than June 30, 2027, unless the parties mutually agree in writing to extend the term.

5.0 COORDINATION OF WORK

5.1 Representative of Contractor. The following principals of Contractor are hereby designated as being the principals and representatives of Contractor authorized to act in its behalf with respect to the work specified herein and make all decisions in connection therewith:

It is expressly understood that the experience, knowledge, capability and reputation of the foregoing principals were a substantial inducement for City to enter into this Agreement. Therefore, the foregoing principals shall be responsible during the term of this Agreement for directing all activities of Contractor and devoting sufficient time to personally supervise the services hereunder. For purposes of this Agreement, the foregoing principals may not be replaced nor may their responsibilities be substantially reduced by Contractor without the express written approval of City.

5.2 Contract Officer. The Contract Officer shall be such person as may be designated by the City Administrator or City Engineer of City. It shall be the Contractor's responsibility to assure that the Contract Officer is kept informed of the progress of the performance of the services and the Contractor shall refer any decisions that must be made by City to the Contract Officer. Unless otherwise specified herein, any approval of City required hereunder shall mean the approval of the Contract Officer. The Contract Officer shall have authority to sign all documents on behalf of the City required hereunder to carry out the terms of this Agreement.

5.3 Prohibition Against Assignment. The experience, knowledge, capability and reputation of Contractor, its principals and employees were a substantial inducement for the City to enter into this Agreement. Neither this Agreement nor any interest herein may be transferred, assigned, conveyed, hypothecated or encumbered voluntarily or by operation of law, whether for the benefit of creditors or otherwise, without the prior written approval of City. Transfers restricted hereunder shall include the transfer to any person or group of persons acting in concert of more than twenty five percent (25%) of the present ownership and/or control of Contractor, taking all transfers into account on a cumulative basis. In the event of any such unapproved transfer, including any bankruptcy proceeding, this Agreement shall be void. No approved transfer shall release the Contractor or any surety of Contractor of any liability hereunder without the express consent of City.

5.4 Independent Contractor. Neither the City nor any of its employees shall have any control over the manner, mode or means by which Contractor, its subcontractors, agents or employees, performs the services required herein, except as otherwise set forth herein. City shall have no voice in the selection, discharge, supervision or control of Contractor's employees, subcontractors, servants, representatives

or agents, or in fixing their number, compensation or hours of service. Contractor shall perform all services required herein as an independent contractor of City and shall remain at all times as to City a wholly independent contractor with only such obligations as are consistent with that role. Contractor shall not at any time or in any manner represent that it or any of its subcontractors, agents or employees are agents or employees of City. City shall not in any way or for any purpose become or be deemed to be a partner of Contractor in its business or otherwise or a joint venture or a member of any joint enterprise with Contractor.

5.5 Identity of Persons Performing Work. Contractor represents that it employs or will employ at its own expense all personnel required for the satisfactory performance of any and all tasks and services set forth herein. Contractor represents that the tasks and services required herein will be performed by Contractor or under its direct supervision, and that all personnel engaged in such work shall be fully qualified and shall be authorized and permitted under applicable State and local law to perform such tasks and services.

5.6 Utility Relocation. City is responsible for removal, relocation, or protection of existing main or trunkline utilities to the extent such utilities were not identified in the invitation for bids or specifications. City shall reimburse contractor for any costs incurred in locating, repairing damage not caused by contractor and removing or relocating such unidentified utility facilities, including equipment idled during such work. Contractor shall not be assessed liquidated damages for delay arising from the removal or relocation of such unidentified utility facilities.

5.7 Trenches or Excavations. Pursuant to California Public Contract Code Section 7104, in the event the work included in this Agreement requires excavations more than four (4) feet in depth, the following shall apply.

- (a) Contractor shall promptly, and before the following conditions are disturbed, notify City, in writing, of any: (1) material that Contractor believes may be material that is hazardous waste, as defined in Section 25117 of the Health and Safety Code, that is required to be removed to a Class I, Class II, or Class III disposal site in accordance with provisions of existing law; (2) Subsurface or latent physical conditions at the site different from those indicated; or (3) Unknown physical conditions at the site of any unusual nature, different materially from those ordinarily encountered and generally recognized as inherent in work of the character provided for in the contract.
- (b) City shall promptly investigate the conditions, and if it finds that the conditions do materially so differ, or do involve hazardous waste, and cause a decrease or increase in Contractor's cost of, or the time required for, performance of any part of the work shall issue a change order per Section 2.9 of this Agreement.
- (c) That, in the event that a dispute arises between City and Contractor whether the conditions materially differ, or involve hazardous waste, or cause a decrease or increase in Contractor's cost of, or time required for, performance of any part of the work, Contractor shall not be excused from any scheduled completion date provided for by the contract, but shall proceed with all work to be performed under the contract. Contractor shall retain any and all rights provided either by contract or by law, which pertain to the resolution of disputes and protests between the contracting parties.

6.0 INSURANCE, INDEMNIFICATION AND BONDS

6.1 Insurance. The Contractor and all subcontractors, if any, shall procure and maintain, at its sole cost and expense, in a form and content satisfactory to City, during the entire term of this Agreement including any extension thereof, insurance as set forth in Exhibit "B" attached hereto and incorporated herein by this reference.

Conditions:

In accordance with Public Contract Code Section 20170, the insurance of surety companies who provide or issue the policy shall have been admitted to do business in the State of California with a credit rating of A- or better.

This insurance shall not be canceled, limited in scope or coverage or non-renewed until after thirty (30) days prior written notice has been given to the Public Works Director, City of La Habra, 110 E. La Habra Blvd., La Habra, California 90631.

Any insurance maintained by the City of La Habra shall apply in excess of and not combined with insurance provided by this policy.

The City of La Habra, its officers, employees, representatives, attorneys, and volunteers shall be named as additional named insureds.

Prior to commencement of any work under this contract, Contractor shall deliver to the City insurance endorsements confirming the existence of the insurance required by this contract, and including the applicable clauses referenced above.

Such endorsements shall be signed by an authorized representative of the insurance company and shall include the signator's company affiliation and title. Should it be deemed necessary by the City, it shall be Contractor's responsibility to see that the City receives documentation, acceptable to the City, which sustains that the individual signing said endorsements is indeed authorized to do so by the insurance company.

If the Contractor fails to maintain the aforementioned insurance, or secure and maintain the aforementioned endorsement, the City may obtain such insurance, and deduct and retain the amount of the premiums for such insurance from any sums due under the agreement. However, procuring of said insurance by the City is an alternative to other remedies the City may have, and is not the exclusive remedy for failure of Contractor to maintain said insurance or secure said endorsement. In addition to any other remedies the City may have upon Contractor's failure to provide and maintain any insurance or policy endorsements to the extent and within the time herein required, the City shall have the right to order Contractor to stop work hereunder, and/or withhold any payment(s) which became due to Contractor hereunder until Contractor demonstrates compliance with the requirements hereof.

Nothing herein contained shall be construed as limiting in any way the extent to which Contractor may be held responsible for payments of damages to persons or property resulting from Contractor's or its subcontractor's performance of the work covered under this agreement.

Each contract between the Contractor and any subcontractor shall require the subcontractor to maintain the same policies of insurance that the Contractor is required to maintain pursuant to this Section 6.1 and Exhibit "B".

6.2 Certificates of Insurance. Contractor shall provide to City certificates of insurance showing the insurance coverages and required endorsements described above, in a form and content approved by City, prior to performing any services under this Agreement. The certificates of insurance and endorsements shall be attached to this Agreement as Exhibit "C", and are incorporated herein by this reference.

6.3 Indemnification. Contractor shall defend, indemnify, hold free and harmless the City of La Habra, its elected and appointed officials, officers, agents and employees, at Contractor's sole expense, from and against any and all actions, suits, claims, damages to persons or property, losses, costs, penalties, obligations, errors, omissions or liabilities, (herein "claims or liabilities") that may be asserted or claimed by any person, firm or entity arising or alleged to arise out of or in connection with the performance of the work, operations or activities of Contractor, its agents, employees, subcontractors, or invitees, provided for herein, or arising or alleged to arise from the negligent acts or omissions of Contractor hereunder, or arising or alleged to arise from Contractor's performance of or failure to perform any term, provision, covenant or condition of this Agreement.

- (a) Contractor will defend any action or actions filed in connection with any of said claims or liabilities and will pay all costs and expenses, including legal costs and attorneys' fees incurred in connection therewith.
- (b) Contractor will promptly pay any judgment rendered against the City, its officers, agents or employees for any such claims or liabilities arising or alleged to arise out of or in connection with Contractor's (or its agents', employees', subcontractors' or invitees') negligent performance of or failure to perform such work, operations or activities hereunder; and Contractor agrees to save and hold the City, its officers, agents, and employees harmless therefrom.
- (c) In the event the City, its officers, agents or employees is made a party to any action or proceeding filed or prosecuted against Contractor for such damages or other claims arising or alleged to arise out of or in connection with the performance of or failure to perform the work, operation or activities of Contractor hereunder, Contractor shall pay to the City, its officers, agents or employees, any and all costs and expenses incurred by the City, its officers, agents or employees in such action or proceeding, including but not limited to, legal costs and attorneys' fees for counsel selected by City.
- (d) Contractor's duty to defend and indemnify as set out in this Section 6.3 shall include any claims, liabilities, obligations, losses, demands, actions, penalties, suits, costs, expenses or damages or injury to persons or property arising or alleged to arise from, in connection with, as a consequence of or pursuant to any state or federal law or regulation regarding hazardous substances, including but not limited to the Federal Insecticide, Fungicide and Rodenticide Act ("FIFRA"), Comprehensive Environmental Response, Compensation and Liability Act of 1980 ("CERCLA"), Resource Conservation and Recovery Act of 1976 ("RCRA"), the Hazardous and Solid Waste Amendments of 1984, the Hazardous Material Transportation Act, the Toxic Substances control Act, the Clean Air Act, the Clean Water Act, the California Hazardous Substance Account Act, the California Hazardous Waste Control Law or the Porter-Cologne Water Quality Control Act, as any of those statutes may be amended from time to time.

Notwithstanding the foregoing, Contractor shall not be liable for the defense or indemnification of the City for claims, actions, complaints or suits arising out of the sole active negligence or willful misconduct of the City.

The Contractor's indemnification obligations pursuant to this Section 6.3 shall survive the termination of this Agreement. Contractor shall require the same indemnification from all subcontractors.

6.4 Labor and Materials and Performance Bonds. Concurrently with execution of this Agreement, Contractor shall deliver to City a labor and materials bond and a performance bond each in the sum of the amount of this Agreement, in the forms provided by the City Clerk, which secures the faithful performance of this Agreement. The bonds shall contain the original notarized signature of an authorized officer of the surety and affixed thereto shall be a certified and current copy of his power of attorney. The bonds shall be unconditional and remain in force during the entire term of the Agreement and shall be null and void only if the Contractor promptly and faithfully performs all terms and conditions of this Agreement.

6.5 Sufficiency of Insurer or Surety. Insurance required by this Agreement shall be satisfactory only if issued by companies qualified to do business in California, rated "A" or better in the most recent edition of Best Rating Guide, The Key Rating Guide or in the Federal Register, and only if they are of a financial category Class VII or better, unless such requirements are waived by the Risk Manager of the City due to unique circumstances.

6.6 Substitution of Securities. Pursuant to California Public Contract Code Section 22300, substitution of eligible equivalent securities for any monies withheld to ensure performance under the contract for the work to be performed will be permitted at the request and expense of the successful bidder.

7.0 RECORDS AND REPORTS

7.1 Reports. Contractor shall periodically prepare and submit to the Contract Officer such reports concerning the performance of the services required by this Agreement as the Contract Officer shall require. Contractor hereby acknowledges that the City is greatly concerned about the cost of work and services to be performed pursuant to this Agreement. For this reason, Contractor agrees that if Contractor becomes aware of any facts, circumstances, techniques, or events that may or will materially increase or decrease the cost of the work or services contemplated herein or, if Contractor is providing design services, the cost of the project being designed, Contractor shall promptly notify the Contract Officer of said fact, circumstance, technique or event and the estimated increased or decreased cost related thereto and, if Contractor is providing design services, the estimated increased or decreased cost estimate for the project being designed.

7.2 Records. Contractor shall keep, and require subcontractors to keep, such books and records (including but not limited to payroll records as required herein) as shall be necessary to perform the services required by this Agreement and enable the Contract Officer to evaluate the performance of such services. The Contract Officer shall have full and free access to such books and records at all times during normal business hours of City, including the right to inspect, copy, audit and make records and transcripts from such records. Such records shall be maintained for a period of three (3) years following completion of the services hereunder, and the City shall have access to such records in the event any audit is required.

7.3 Ownership of Documents. All drawings, specifications, reports, records, documents and other materials prepared by Contractor, its employees, subcontractors and agents in the performance of this Agreement shall be the property of City and shall be delivered to City upon request of the Contract Officer or upon the termination of this Agreement, and Contractor shall have no claim for further employment or additional compensation as a result of the exercise by City of its full rights of ownership of the documents and materials hereunder. Contractor may retain copies of such documents for its own use. Contractor shall have an unrestricted right to use the concepts embodied therein. All subcontractors shall

provide for assignment to City of any documents or materials prepared by them, and in the event Contractor fails to secure such assignment, Contractor shall indemnify City for all damages resulting therefrom.

7.4 Public Records Act Disclosure. Contractor has been advised and is aware that this Agreement and all reports, documents, information and data, including, but not limited to, computer tapes, discs or files furnished or prepared by Contractor, or any of its subcontractors, pursuant to this Agreement and provided to City may be subject to public disclosure as required by the California Public Records Act (California Government Code Section 6250 *et seq.*). Exceptions to public disclosure may be those documents or information that qualify as trade secrets, as that term is defined in the California Government Code Section 6254.7, and of which Contractor informs City of such trade secret. The City will endeavor to maintain as confidential all information obtained by it that is designated as a trade secret. The City shall not, in any way, be liable or responsible for the disclosure of any trade secret including, without limitation, those records so marked if disclosure is deemed to be required by law or by order of the Court.

8.0 GENERAL PROVISIONS

8.1 Governing Law. This Agreement shall be construed and interpreted both as to validity and to performance of the parties in accordance with the laws of the State of California. Legal actions concerning any dispute, claim or matter arising out of or in relation to this Agreement shall be instituted in the Superior Court of the County of Orange, State of California, or any other appropriate court in such county, and Contractor covenants and agrees to submit to the personal jurisdiction of such court in the event of such action.

8.2 Representatives. The City Administrator or his or her designee shall be the representative of City for purposes of this Agreement and may issue all consents, approvals, directives and agreements on behalf of the City, called for by this Agreement, except as otherwise expressly provided in this Agreement.

The Principal set forth in Section 5.1 above shall be the representative for Contractor for purposes of this Agreement, and shall be authorized to issue all consents, approvals, directives and agreements on behalf of Contractor called for by this Agreement, except as otherwise expressly provided in this Agreement.

8.3 Disputes. In the event either party fails to perform its obligations hereunder, the nondefaulting party shall provide the defaulting party written notice of such default. The defaulting party shall have ten (10) days to cure the default; provided that, if the default is not reasonably susceptible to being cured within said ten (10) day period, the defaulting party shall have a reasonable time to cure the default, not to exceed a maximum of thirty (30) days, so long as the defaulting party commences to cure such default within ten (10) days of service of such notice and diligently prosecutes the cure to completion; provided further that if the default is an immediate danger to the health, safety and general welfare, the defaulting party shall take such immediate action as may be necessary. Notwithstanding the foregoing, the nondefaulting party may, in its sole and absolute discretion, grant a longer cure period. Should the defaulting party fail to cure the default within the time period provided in this Section, the nondefaulting party shall have the right, in addition to any other rights the nondefaulting party may have at law or in equity, to terminate this Agreement. Compliance with the provisions of this Section 8.3 shall be a condition precedent to bringing any legal action, and such compliance shall not be a waiver of any party's right to take legal action in the event that the dispute is not cured.

8.4 Retention of Funds. Progress payments shall be made in accordance with the provisions of Section 3.2 of this Agreement. In accordance with said section, City shall pay Contractor a sum based upon ninety-five percent (95%) of the contract price apportionment of the labor and materials incorporated into

the work under the contract during the month covered by said statement. The remaining five percent (5%) thereof shall be retained as performance security to be paid to the Contractor within sixty (60) days after final acceptance of the work by the City Council, after Contractor shall have furnished City with a release of all undisputed contract amounts if required by City. In the event there are any claims specifically excluded by Contractor from the operation of the release, the City may retain proceeds (per Public Contract Code 7107) of up to 150% of the amount in dispute. City's failure to deduct or withhold shall not affect Contractor's obligations hereunder.

8.5 Waiver. No delay or omission in the exercise of any right or remedy by a nondefaulting party on any default shall impair such right or remedy or be construed as a waiver. A party's consent to or approval of any act by the other party requiring the party's consent or approval shall not be deemed to waive or render unnecessary the other party's consent to or approval of any subsequent act. Any waiver by either party of any default must be in writing and shall not be a waiver of any other default concerning the same or any other provision of this Agreement.

8.6 Rights and Remedies. Rights and Remedies are cumulative except with respect to rights and remedies expressly declared to be exclusive in this Agreement, the rights and remedies of the parties are cumulative and the exercise by either party of one or more of such rights or remedies shall not preclude the exercise by it, at the same or different times, of any other rights or remedies for the same default or any other default by the other party.

8.7 Legal Action. In addition to any other rights or remedies, either party may take legal action, in law or in equity, to cure, correct or remedy any default, to recover damages for any default, to compel specific performance of this Agreement, to obtain declaratory or injunctive relief, or to obtain any other remedy consistent with the purposes of this Agreement.

8.8 Liquidated Damages. Since the determination of actual damages for any delay in performance of this Agreement would be extremely difficult or impractical to determine in the event of a breach of this Agreement, the Contractor and its sureties shall be liable for and shall pay to the City Five Hundred Dollars (\$500.00) as liquidated damages for each working day of delay in the performance of any service required hereunder, as specified in the Scope of Services (Exhibit A). The City may withhold from any monies payable on account of services performed by the Contractor any accrued liquidated damages.

8.9 Termination for Default of Contractor. If termination is due to the failure of the Contractor to fulfill its obligations under this Agreement, Contractor shall vacate any City owned property which Contractor is permitted to occupy hereunder and City may, after compliance with the provisions of Section 8.3, take over the work and prosecute the same to completion by contract or otherwise, and the Contractor shall be liable to the extent that the total cost for completion of the services required hereunder exceeds the compensation herein stipulated (provided that the City shall use reasonable efforts to mitigate such damages), and City may withhold any payments to the Contractor for the purpose of setoff or partial payment of the amounts owed the City as previously stated.

8.10 Notice. Any notice, demand, request, document, consent, approval, or communication either party desires or is required to give to the other party or any other person shall be in writing and shall be deemed to be given when served personally or deposited in the US Mail, prepaid, first-class mail, return receipt requested, addressed as follows:

To City: City of La Habra
110 E. La Habra Blvd
La Habra, California 90631
Attn.: Albert Mendoza

To Contractor:

8.11 Non-liability of City Officers and Employees. No officer or employee of the City shall be personally liable to the Contractor, or any successor in interest, in the event of any default or breach by the City or for any amount which may become due to the Contractor or to its successor, or for breach of any obligation of the terms of this Agreement.

8.12 Conflict of Interest. The Contractor warrants that it has not paid or given and will not pay or give any third party any money or other consideration for obtaining this Agreement.

Contractor and its officers, employees, associates and subcontractors, if any, will comply with all conflict of interest statutes of the State of California applicable to Contractor's services under this agreement, including, but not limited to, the Political Reform Act (Government Code Sections 81000, *et seq.*) and Government Code Section 1090. During the term of this Agreement, Contractor and its officers, employees, associates and subcontractor shall not, without the prior written approval of the City Representative, perform work for another person or entity for whom Contractor is not currently performing work that would require Contractor or one of its officers, employees, associates or subcontractors to abstain from a decision under this Agreement pursuant to a conflict of interest statute.

8.13 Covenant Against Discrimination. Contractor covenants that, by and for itself, its heirs, executors, assigns, and all persons claiming under or through them, that there shall be no discrimination against or segregation of, any person or group of persons on account of race, color, creed, religion, sex, marital status, national origin, or ancestry in the performance of this Agreement. To the extent required by law, contractor shall take affirmative action to insure that applicants are employed and that employees are treated during employment without regard to their race, color, creed, religion, sex, marital status, national origin, or ancestry.

8.14 Interpretation. The terms of this Agreement shall be construed in accordance with the meaning of the language used and shall not be construed for or against either party by reason of the authorship of this Agreement or any other rule of construction which might otherwise apply.

8.15 Severability. In the event that any one or more of the phrases, sentences, clauses, paragraphs, or sections contained in this Agreement shall be declared invalid or unenforceable by a valid judgment or decree of a court of competent jurisdiction, such invalidity or unenforceability shall not affect any of the remaining phrases, sentences, clauses, paragraphs, or sections of this Agreement which are hereby declared as severable and shall be interpreted to carry out the intent of the parties hereunder unless the invalid provision is so material that its invalidity deprives either party of the basic benefit of their bargain or renders this Agreement meaningless.

8.16 [reserved]

8.17 Unfair Business Practices Claims. In entering into a public works contract or a subcontract to supply goods, services or materials pursuant to a public works contract, the contractor or subcontractor offers and agrees to assign to the awarding body all rights, title, and interest in and to all causes of action it may have under Section 4 of the Clayton Act (15 U.S.C. Sec. 15) or under the Cartwright Act (Chapter 2, (commencing with Section 16700) of Part 2 of Division 7 of the Business and Professions

Code), arising from purchases of goods, services or materials pursuant to the public works contract or the subcontract. This assignment shall be made and become effective at the time the awarding body renders final payment to the contractor without further acknowledgment by the parties. (Sec. 7103.5, California Public Contract Code).

8.18 Corporate Authority. The persons executing this Agreement on behalf of the parties hereto warrant that (i) such party is duly organized and existing, (ii) they are duly authorized to execute and deliver this Agreement on behalf of said party, (iii) by so executing this Agreement, such party is formally bound to the provisions of this Agreement, and (iv) the entering into this Agreement does not violate any provision of any other Agreement to which said party is bound.

8.19 PERS Eligibility Indemnification. In the event that Contractor or any employee, agent, or subcontractor of Contractor providing services under this Agreement claims or is determined by a court of competent jurisdiction or the California Public Employees Retirement System (PERS) to be eligible for enrollment in PERS as an employee of the City, Contractor shall indemnify, defend, and hold harmless City for the payment of any employee and/or employer contributions for PERS benefits on behalf of Contractor or its employees, agents, or subcontractors, as well as for the payment of any penalties and interest on such contributions, which would otherwise be the responsibility of City.

Notwithstanding any other agency, state or federal policy, rule, regulation, law or ordinance to the contrary, Contractor and any of its employees, agents, and subcontractors providing service under this Agreement shall not qualify for or become entitled to, and hereby agree to waive any claims to, any compensation, benefit, or any incident of employment by City, including but not limited to eligibility to enroll in PERS as an employee of City and entitlement to any contribution to be paid by City for employer contribution and/or employee contributions for PERS benefits.

8.20 Cooperation. In the event any claim or action is brought against City relating to Contractor's performance or services rendered under this Agreement, Contractor shall render any reasonable assistance and cooperation which City might require.

8.21 Legal Responsibilities. The Contractor shall keep itself informed of City, State, and Federal laws, ordinances and regulations, which may in any manner affect the performance of its services pursuant to this Agreement. The Contractor shall at all times observe and comply with all such laws, ordinances and regulations. Neither the City, nor its officers, agents, or employees shall be liable at law or in equity as a result of the Contractor's failure to comply with this section.

8.22 Termination for Convenience. The City may terminate this Agreement without cause for convenience of the City upon giving contractor 30 days prior written notice of termination of the Agreement. Upon receipt of the notice of termination the Contractor shall cease all further work pursuant to the Agreement. Upon such termination by the City the Contractor shall not be entitled to any other remedies, claims, actions, profits, or damages except as provided in this paragraph. Upon the receipt of such notice of termination Contractor shall be entitled to the following compensation:

1. The contract value of the work completed to and including the date of receipt of the notice of termination, less the amount of progress payments received by contractor.

2. Actual move-off costs including labor, rental fees, equipment transportation costs, the costs of maintaining on-site construction office for supervising the mover-off.

3. The cost of materials custom made for this Agreement which cannot be used by the Contractor in the normal course of his business, and which have not been paid for by City in progress payments.

4. All costs shall not include any markups as might otherwise be allowed by any plans or specifications which were a part of the Agreement.

The provisions of this paragraph shall supersede any other provision of the Agreement or any provision of any plans, specification, addendums or other documents which are or may become a part of this Agreement. City and Contractor agree that the provisions of this paragraph are a substantive part of the consideration for this Agreement.

8.23 Responsibility for Errors. Contractor shall be responsible for its work and results under this Agreement. Contractor, when requested, shall furnish clarification and/or explanation as may be required by the City's representative, regarding any services rendered under this Agreement at no additional cost to City. In the event that an error or omission attributable to Contractor occurs, then Contractor shall, at no cost to City, provide all necessary design drawings, estimates and other Contractor professional services necessary to rectify and correct the matter to the sole satisfaction of City and to participate in any meeting required with regard to the correction.

8.24 Order of Precedence. In the event of an inconsistency in this Agreement and any of the attached Exhibits, the terms set forth in this Agreement shall prevail. If, and to the extent this Agreement incorporates by reference any provision of any document, such provision shall be deemed a part of this Agreement. Nevertheless, if there is any conflict among the terms and conditions of this Agreement and those of any such provision or provisions so incorporated by reference, this Agreement shall govern over the document referenced.

8.25 Costs. Each party shall bear its own costs and fees incurred in the preparation and negotiation of this Agreement and in the performance of its obligations hereunder except as expressly provided herein.

8.26 No Third Party Beneficiary Rights. This Agreement is entered into for the sole benefit of City and Contractor and no other parties are intended to be direct or incidental beneficiaries of this Agreement and no third party shall have any right in, under or to this Agreement.

8.27 Headings. Paragraphs and subparagraph headings contained in this Agreement are included solely for convenience and are not intended to modify, explain or to be a full or accurate description of the content thereof and shall not in any way affect the meaning or interpretation of this Agreement.

8.28 Construction. The parties have participated jointly in the negotiation and drafting of this Agreement. In the event an ambiguity or question of intent or interpretation arises with respect to this Agreement, this Agreement shall be construed as if drafted jointly by the parties and in accordance with its fair meaning. There shall be no presumption or burden of proof favoring or disfavoring any party by virtue of the authorship of any of the provisions of this Agreement.

8.29 Counterparts. This Agreement may be executed in one or more counterparts, each of which shall be deemed an original. All counterparts shall be construed together and shall constitute one agreement.

8.30 Funding Source Conditions – Contractor’s Obligation. Contractor acknowledges that the City may be paying for the Project by using funds it receives or will receive from various funding sources in the form of grants and/or subsidies, and the like under certain terms and conditions. Contractor acknowledges and agrees that any failure of the Contractor and/or its subcontractors to perform its obligations under the Contract, including, but not limited to, timely submitting accurate reports and records, that in any way results in the City not meeting the terms and conditions placed on the funds by the funding source, or forfeiting its entitlement to or, otherwise, not receiving, the funds, then the Contractor shall be liable to pay the City for the funds not granted to the City on the Project.

8.31 Entire Agreement. This Agreement constitutes the entire agreement between the parties with respect to any matter referenced herein and supersedes any and all other prior writings and oral negotiations. This Agreement may be modified only in writing, and signed by the parties in interest at the time of such modification. The terms of this Agreement shall prevail over any inconsistent provision in any other contract document appurtenant hereto, including exhibits to this Agreement.

IN WITNESS WHEREOF, the parties have executed and entered into this Agreement as of the date first written above.

CITY OF LA HABRA,
A municipal corporation

Jim Sadro, City Manager

Date: _____

CONTRACTOR

Signature

Date: _____

Name and Title

Social Security or Taxpayer ID Number

ATTEST:

Rhonda J. Barone, City Clerk

Date: _____

APPROVED AS TO FORM:

Keith F. Collins, City Attorney

Date: _____

(Use of City Bond Form is Required)

**LABOR AND MATERIAL PAYMENT BOND
PUBLIC WORK (CALIFORNIA)**

KNOW ALL MEN BY THESE PRESENT:

WHEREAS, _____, as Principal, has entered into a contract dated _____, with the City of La Habra (Obligee) referred to and made a part hereof to perform the following work, to wit: _____ and all appurtenant work in accordance with PROJECT NO. _____, which requires Principal to file this bond to secure claims made in relation to the project.

NOW THEREFORE, we, _____, as Principal, and _____, a corporation organized under the laws of _____ and duly authorized to transact business in the State of California, as Surety, are held firmly bound unto the City of La Habra, as Obligee, and all sub-contractors, laborers, material persons and other persons employed in the performance of the referenced agreement, in the sum of _____ Dollars (\$ _____ .00), lawful money of the United States of America, for the payment whereof well and truly to be made the Principal and Surety bind themselves, their heirs, executors, administrators, successors, and assigns, jointly and severally, firmly by these presents.

If the above bounden PRINCIPAL, his or its heirs, executors, administrators, successors, assigns, or any of his or its sub-contractors, fails to pay for any materials, provisions, provender, or other supplies, or teams, implements or machinery, used in, upon, for or about the performance of the work contracted to be done, or for any work or labor to persons named in Section 9100 or the Civil Code, thereon of any kind, or for amounts due under the Unemployment Insurance Code with respect to such work or labor deducted, withheld and paid over to the Employment Development Department from the wages of employees of the contractor and sub-contractors pursuant to Section 13020 of the Unemployment Insurance Code, that the SURETY on this bond will pay the same, in an amount not exceeding the sum specified in this bond, AND ALSO, in case suit is brought upon this bond, a reasonable attorney's fee, which shall be awarded by the court to the prevailing party in said suit, said attorney's fee to be taxed as costs in said suit and to be included in the judgment herein rendered.

As part of the obligation secured hereby, the SURETY shall not be exonerated or released from the obligation of the bond by any change, alteration, or modification in or of any contract, plans, specifications, or agreement pertaining or relating to any scheme or work of improvement or pertaining or relating to the furnishing of labor, materials, or equipment therefor, nor by any change or modification of any terms of payment or extension of the time for any payment pertaining or relating to any scheme of work of improvement, nor by any rescission or attempted rescission of the contract, agreement or bond, nor by any conditions precedent or subsequent in the bond attempting to limit the right of recovery of claimants otherwise entitled to recover under

any such contract or agreement, or under the bond, nor, where the bond is given for the benefit of claimants, by any fraud practiced by any person other than the claimant seeking to recover on the bond.

This bond shall inure to the benefit of any and all persons, companies and corporations entitled to file claims under the Civil Code so as to give them a right of action in a suit on this bond.

This bond is executed for the purpose of complying with the laws of the State of California and shall inure to the benefit of any of the persons named in Section 9100 of the Civil Code of the State of California.

IN WITNESS THEREOF, we have hereunto set our hands and seals this _____ day of _____, 20__.

(Corporate Seal)

Principal

By _____

Title

(Corporate Seal)

Principal

By _____

Title

APPROVED AS TO FORM:
/s/ Keith F. Collins
City Attorney

FAITHFUL PERFORMANCE BOND

KNOW ALL MEN BY THESE PRESENTS:

That we, _____

_____ hereinafter referred to as

“Contractor”, as principal, and _____

_____ as surety, are held and firmly

bound unto City of La Habra in the sum of _____

_____ Lawful money of the United States of America for the payment of which sum well and truly to be made we bind ourselves jointly and severally, firmly by these presents.

The condition of the foregoing obligation is such that WHEREAS, said Contract has been awarded and is about to enter into the annexed contract with City of La Habra for construction of Street Improvements as specifically set forth in the documents entitled:

**MACY STREET REHABILITATION PROJECT
CITY PROJECT NO. 1-R-23**

and is required under the terms of the Contract to give this bond in connection with the execution of said contract.

NOW, THEREFORE, if the said Contractor shall well and truly do and perform all of the covenants and obligations of said contract on his part to be done and performed at the times and in the manner specified herein, then this obligation shall be null and void, otherwise it shall be and remain in full force and effect.

PROVIDED, that any alterations in the work to be done or the materials to be furnished which may be made pursuant to the terms of said Contract shall not in any way release either the Contractor or the surety thereunder nor shall any extensions of time granted under the provisions of said Contract release either the Contractor or the surety, and notice of such alterations or extensions of the Contract is hereby waived by the surety.

WITNESS our hands this _____ day of _____, 2025.

Contractor

BY: _____

(Seal)

Title

APPROVED:

Surety

BY: _____

(Seal)

Mailing Address of Surety:

Telephone Number of Surety

(Use of City form is required)

SUPPLEMENTAL INFORMATION TO BE COMPLETED BY PRINCIPAL

If an individual, so state. If a firm or co-partnership, state the firm and give the names of all individual co-partners composing the partnership. If a Corporation, state legal name of corporation; state also the names of the president, secretary, treasurer and manager thereof.

Business Address: _____

Telephone Number: _____

Date: _____

Print Name: _____
Principal

Signature: _____
Title

(Use of City form
is required)

TAX IDENTIFICATION NUMBER

The Tax Equity and Fiscal Responsibility Act of 1982 requires the payer (City of La Habra) to report to the Internal Revenue Service taxable payments to payees.

You (as a payee) are required by law to provide us with your Taxpayer Identification Number (if an individual or partnership, your Social Security Number). If you do not provide us with your correct identification number, you may be subject to a penalty imposed by the Internal Revenue Service. The payments subject to withholdings may include, but are not limited to, interest, dividends, or other payments the City of La Habra made to you. Other payments may include rents, royalties, commissions and fees for service of non-employees.

If you are exempt from income tax, we are still required, by law, to maintain a Tax Identification Number on file. **PLEASE PROVIDE YOUR TAX IDENTIFICATION NUMBER next to the appropriate listing below, sign, date and return to:**

CITY OF LA HABRA FINANCE DEPARTMENT
110 E. La Habra Blvd
La Habra, CA 90631

Exempt: Yes___ No___ Telephone () _____

CORPORATION: _____

U.S.A. OR ANY AGENCIES THEREOF: _____

IRS CODE #501 TAX-EXEMPT ORGANIZATION: _____

A NON-COMMISSIONED CITY OF LA HABRA EMPLOYEE: _____

SOLE PROPRIETOR: _____

A PARTNERSHIP: _____

OTHER: _____ (Explain)

Signature/Title: _____ Date: _____

BID GUARANTEE

**TO THE CITY OF LA HABRA
MACY STREET REHABILITATION PROJECT, CITY PROJECT NO. 1-R-23**

As a material inducement to the City to award the contract for Project No. _____ to _____, the undersigned (“Guarantor”) has agreed to enter into this guarantee. The Guarantor hereby unconditionally guarantees to the fullest extent allowed by law the following work included in this project: _____ (“the work”).

Guarantor guarantees that the materials and equipment used by itself and its subcontractors will be free from defects and that the work will conform to the plans and specifications. Should any of the materials or equipment prove defective or should the work as a whole, or any part thereof, prove defective for any reason whatsoever (except due to intentional torts by the City), or should the work as a whole or any part thereof fail to operate properly or fail to comply with the plans and specifications, Guarantor will, at the City’s sole election: 1) reimburse the City, upon written demand, for all of the City’s expenses incurred replacing or restoring any such equipment or materials, including the cost of any work necessary to make such replacement or repairs; or 2) replace any such defective material or equipment and repair said work completely, all without any cost to the City. Guarantor further guarantees that any such repair work will conform to the plans and specifications for the project. This guarantee will remain in effect for one year from the date on which the contracted for work is accepted for use by the City.

Guarantor understands and agrees that the City shall have the unqualified option to make any replacements or repairs itself or to have such replacement, repair, performed by the undersigned. The City shall have no obligation to consult with Guarantor before the City proceeds to perform any repair, replacement, or work itself. If the City elects to have Guarantor perform said repair, replacement, or work, Guarantor agrees that the repair, replacement, or work shall be performed within 15 days after receipt of a written demand from the City.

If the City elects to perform the replacement, repairs itself, Guarantor agrees to make reimbursement payment within 15 days after receipt of a written demand for payment from the City.

If the Guarantor fails or refuses to comply with this guarantee, the City shall be entitled to all costs and expenses, including attorneys and expert fees, reasonably incurred by reason of Guarantor’s failure or refusal.

Guarantor _____ Date: _____

Contractor: _____ By: _____

Title: _____

STATEMENT OF NON COLLUSION BY CONTRACTOR

The undersigned who submits herewith to the City of La Habra a bid or proposal does hereby certify:

- a. That all statements of fact in such bid or proposal are true;
- b. That such bid or proposal was not made in the interest of or on behalf of any undisclosed person, partnership, company, association, organization or corporation;
- c. That such bid or proposal is genuine and not collusive or sham;
- d. That said bidder has not, directly or indirectly by agreement, communication or conference with anyone, attempted to induce action prejudicial to the interest of the City of La Habra or of any other bidder or anyone else interested in the proposed procurement;
- e. Did not, directly or indirectly, collude, conspire, connive or agree with anyone else that said bidder or anyone else would submit a false or sham bid or proposal, or that anyone should refrain from bidding or withdraw his bid or proposal;
- f. Did not in any manner, directly or indirectly seek by agreement, communication or conference with anyone to raise or fix the bid or proposal price of said bidder or of anyone else, or to raise or fix any overhead, profit or cost element of his bid or proposal price, or that of anyone else;
- g. Did not, directly or indirectly, submit his bid or proposal price or any breakdown thereof, or the contents thereof, or divulge information or data relative thereto, to any corporation, partnership, company, association, organization, bid depository, or to any member agent thereof, or to any individual or group of individuals, except to the City of La Habra, or to any person or persons who have a partnership or their financial interest with said bidder in his business.
- h. Did not provide, directly or indirectly to any officer or employee of the City of La Habra any gratuity, entertainment, meals, or anything of value, whatsoever, which could be objectively construed as intending to invoke any form of reciprocation or favorable treatment.
- i. That no officer or principal of the undersigned firm is related to any officer or employee of the city by blood or marriage within the third degree or is employed, either full or part time, by the City of La Habra either currently or within the last two (2) years.
- j. That no officer or principal of the undersigned firm nor any subcontractor to be engaged by the principal has been convicted by a court of competent jurisdiction of any charge of fraud, bribery, collusion, conspiracy or any other act in violation of any state or federal antitrust law in connection with the bidding upon award of, or performance of, any public work contract, with any public entity, within the last three years.

I certify, under penalty of perjury under the laws of the State of California, that the foregoing is true and correct and that this certification was executed:

On _____ at _____ California.

Firm _____

(Signature)

Street _____

(Print Name & Title)

City _____ State _____ Zip _____

CERTIFICATION OF COMPLIANCE

AFFIRMATIVE ACTION REQUIREMENTS

EQUAL EMPLOYMENT OPPORTUNITY

For

**MACY STREET REHABILITATION PROJECT
CITY PROJECT NO. 1-R-23**

_____ Certifies that:

(Contractor)

It has adopted and approved affirmative action plan in compliance with Title VII of the Civil Rights Act and the Equal Employment Opportunity Act of 1972 and agrees to submit a copy of that plan to the Assistant to the City Manager/Personnel of the City of La Habra for inspection prior to the award of contract.

Signed: _____

By: _____

Title: _____

Date: _____

EXHIBIT A
SCOPE OF SERVICES

EXHIBIT B
INSURANCE REQUIREMENTS

Contractor shall maintain and shall require all of its subcontractors, consultants, and other agents to maintain the insurance listed below. Any requirement for insurance to be maintained after completion of the work shall survive this agreement.

CITY reserves the right to review any and all of the required insurance policies and/or endorsements, but has no obligation to do so. Failure to demand evidence of full compliance with the insurance requirements set forth in this agreement or failure to identify any insurance deficiency shall not relieve Contractor from, nor be construed or deemed a waiver of, its obligation to maintain the required insurance at all times during the performance of this agreement.

A. Workers Compensation & Employers Liability Insurance

- Workers Compensation insurance with statutory limits as required by the Labor Code of the State of California.
- Employers Liability with limits of \$1,000,000 per Accident; \$1,000,000 Disease per employee; \$1,000,000 Disease per policy.
- The policy shall include a written waiver of the insurer's right to subrogate against CITY.
- Required Evidence Of Coverage:
 1. Subrogation waiver endorsement; and
 2. Properly completed Certificate of Insurance.

B. General Liability Insurance

- Commercial General Liability Insurance no less broad than Insurance Services Office (ISO) form CG 00 01.
- Coverage shall be on a standard occurrence form. Claims-Made forms are not acceptable without prior written consent. Modified, limited or restricted Occurrence forms are not acceptable without prior written consent.
- Minimum Limits: \$2,000,000 per Occurrence; \$4,000,000 General Aggregate; \$4,000,000 Products/Completed Operations Aggregate. The General Aggregate shall apply separately to each project. The required limits may be provided by a combination of General Liability Insurance and Commercial Excess or Umbrella Liability Insurance. If contractor maintains higher limits than the specified minimum limits, CITY requires and shall be entitled to coverage for the higher limits maintained by contractor.
- Any deductible or self-insured retention shall be shown on the Certificate of Insurance. If the deductible or self-insured retention exceeds \$25,000 it must be approved in advance by CITY. Contractor is responsible for any deductible or self-insured retention and shall fund it upon CITY'S written request, regardless of whether Contractor has a claim against the insurance or is named as a party in any action involving CITY.
- Coverage shall be continued for one (1) year after completion of the work.
- CITY shall be endorsed as an additional insured for liability arising out of ongoing and completed operations by or on behalf of the contractor. CITY shall continue to be an additional insured for completed operations for (1) year after completion of the work.
- The policy definition of "insured contract" shall include assumptions of liability

arising out of both ongoing operations and the products-completed operations hazard (“P” definition of insured contract in ISO form CG 00 01, or equivalent).

- The insurance provided to the additional insureds shall be primary to, and non-contributory with, any insurance or self-insurance program maintained by them.
- The policy shall cover inter-insured suits and include a “Separation of Insureds” or “severability” clause which treats each insured separately.
- The policy shall be endorsed to include a written waiver of the insurer’s right to subrogate against all persons or entities that are, or are required to be, additional insureds.
- The policy shall not contain a Contractors' Warranty or other similar language which eliminates or restricts insurance because of a subcontractor's failure to carry specific insurance or to supply evidence of such insurance.
- Required Evidence of Coverage:
 1. Copy of the additional insured endorsement or policy language granting additional insured status;
 2. Copy of the endorsement or policy language indicating that coverage applicable to the additional insureds is primary and non-contributory;
 3. Properly completed Certificate of Insurance; and
 4. Completed and signed Agent/Broker Questionnaire with supporting documentation as required.
 5. City of Whittier shall also be listed as additionally insured.

C. Automobile Liability Insurance

- Minimum Limit: \$2,000,000 combined single limit per accident.
- Coverage shall apply to all owned, hired and non-owned vehicles.
- CITY shall qualify as an insured.
- Required Evidence of Coverage:
 1. Copy of the endorsement or policy language indicating that CITY is an insured; and
 2. Properly completed Certificate of Insurance.
 3. City of Whittier shall also be listed as additionally insured.

D. Surety Bonds

- Bid bond.
- Performance and payment bonds for the entire contract price.
- The surety must be authorized to issue these bonds in the State of California.

E. Standards for Insurance Companies

- Insurers, other than the California State Compensation Insurance Fund, shall have an A.M. Best's rating of at least A:VII.

F. Documentation

- The Certificate of Insurance shall include the following reference: [Macy Street Rehabilitation Project. Fiscal Year 2022-2023 City of La Habra Project 1-R-23]
- The name and address for Additional Insured endorsements and Certificates of Insurance is: City of La Habra and City of Whittier

- Contractor shall supply sufficient insurance as set forth by Caltrans and the City of Whittier at no additional cost to the City of La Habra
- Contractor shall provide immediate written notice if: (1) any of the required insurance policies is terminated; (2) the limits of any of the required policies are reduced; or (3) the deductible or self-insured retention is increased.
- Current Evidence of Coverage shall be provided for the entire required period of insurance.
- Upon written request, certified copies of required insurance policies shall be provided within thirty (30) days.

EXHIBIT C

CERTIFICATES OF INSURANCE AND ENDORSEMENTS

EXHIBIT D
CLAIMS PROCEDURE

SUMMARY OF PUBLIC CONTRACT CODE § 9204

The following procedure will apply to any claims by the Contractor on the City:

A “claim” is a separate demand on the City by a contractor on a public works project and sent by registered mail or certified mail with return receipt requested, for one or more of the following:

- A time extension, including relief from penalties for delay
- Payment by the City of money damages under the terms of the contract
- Payment of an amount that is disputed by the City

Initial Review

The claim must be supported by appropriate documentation. The City has 45 days within which to review the claim and provide the contractor with a written statement identifying the disputed and undisputed portions of the claim. If the City does not issue a written statement, the claim is deemed rejected in its entirety. The City will pay any undisputed portion of the claim within 60 days of issuing the statement.

Meet & Confer

If the contractor disputes the City’s written response, or if the City does not issue one, the contractor may request in writing an informal conference to meet and confer for possible settlement of the claim. The City will schedule the meet and confer conference within 30 days of this request and provide a written statement identifying the remaining disputed and undisputed portions of the claim within 10 business days of the meet and confer. The City will pay the undisputed portion within 60 days of issuing this statement.

Mediation

With respect to any disputed portion remaining after the meet and confer, the City and contractor will submit the matter to nonbinding mediation, agree to a mediator within 10 business days after issuing the written statement, and share mediation costs equally. If mediation is unsuccessful, then the terms of the public works agreement and applicable law will govern resolution of the dispute.

Miscellaneous Provisions

Amounts not paid by the City in a timely manner bear interest at 7% per annum. Subcontractors may submit claims via this procedure through the general contractor. The City and contractor may waive the requirement to mediate, but cannot otherwise waive these claim procedures.

APPENDIX “A”

PROJECT PLANS

CITY OF LA HABRA ENGINEERING DEPARTMENT

MACY STREET REHABILITATION PROJECT PROJECT NO. 1-R-23

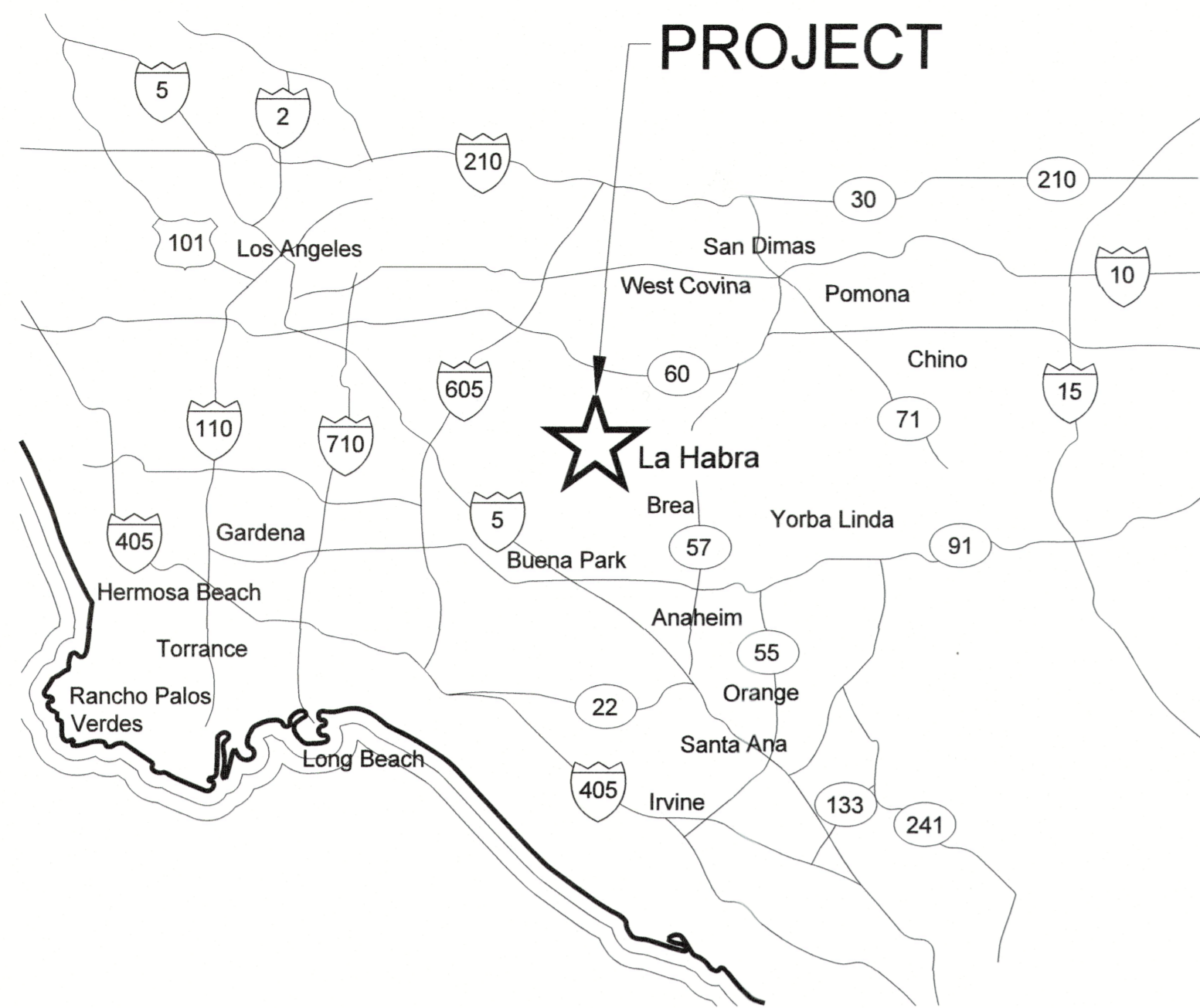

SITE MAP
N.T.S.

SHEET INDEX

SHEET NO.	DESCRIPTION
01	TITLE SHEET
02	TYPICAL SECTIONS
03	DETAILS
04-07	PAVEMENT IMPROVEMENTS
08-11	STRIPING PLANS

UTILITY CONTACTS

AT&T	YVETTE GAROFANO	(714) 618-9146
CALIFORNIA DOMESTIC WATER COMPANY	CHE VENEGAS	(562) 947-3811
CHEVRON USA	DAVE ZERLER	(310) 669-4014
CITY OF LA HABRA SEWER AND WATER DEPT.	BRIAN JONES	(562) 383-4170
COMCAST CABLE COMPANY	SIR/MADAM	(800) 501-5738
CRIMSON PIPELINE	APRIL HARVEY	(562) 285-4195
CR&R (WASTE HAULER)	SIR/MADAM	(714) 372-8209
FRONTIER COMMUNICATIONS	PHILLIP OLIVAS	(909) 480-9286
KINDER MORGAN	DON QUINN	(714) 560-4400
LA HABRA HEIGHTS WATER COMPANY	JOE MATHEWS	(562) 697-6769
METROPOLITAN WATER DISTRICT	MATT PARRY	(714) 577-5084
MOBIL OIL	RUTH CRONIN-FRUITT	(310) 212-1761
ORANGE COUNTY SANITATION DISTRICT	DANIEL LEE	(714) 593-7176
PLAINS ALL AMERICAN PIPELINE	JOE MATTEO	(562) 728-2368
SO CAL EDISON	JIMMY PARKIN	(714) 578-3434
SO CAL GAS	KEITH BROWN	(840) 201-8017
SHELL PIPE COMPANY	CLARINDA MALDONADO	(310) 816-2063
SUBURBAN WATER SYSTEMS	JAMES CHO	(626) 543-2548
SPECTRUM	DOMINIC HERNANDEZ	(714) 287-9385
TORRANCE LOGISTICS COMPANY	TERI A. SHINDE	(310) 212-1794
UNOCAL	ARNA ADAMS	(213) 864-5663
WESCON C/O VINTAGE PRODUCTION	EMILIO RODRIGUEZ	(562) 665-9255
UNDERGROUND SERVICE ALERT	SIR/MADAM	(800) 227-2600
ELLER MEDIA	SIR/MADAM	(714) 289-2018
ORANGE COUNTY FLOOD CONTROL DISTRICT	ALEC GAMEZ	(714) 788-9829

NOTES TO CONTRACTOR

- ACTUAL EXISTING SITE CONDITIONS MAY DIFFER FROM THOSE SHOWN. THE CONTRACTOR SHALL VERIFY SITE CONDITIONS PRIOR TO BIDDING. LOCATIONS OF EXISTING AND ABANDONED UTILITIES ARE UNKNOWN OR FROM RECORD DATA ONLY. THE CONTRACTOR SHALL VERIFY TO HIS SATISFACTION LOCATIONS OF ALL UTILITIES PRIOR TO BIDDING AND CONSTRUCTION. CONTRACTOR SHALL MAINTAIN AS-BUILT RECORDS OF EXISTING UTILITIES AND INFORM THE ENGINEER IN CASE OF DISCREPANCIES.
- THE CONSTRUCTION CONTRACTOR AGREES THAT IN ACCORDANCE WITH GENERALLY ACCEPTED CONSTRUCTION PRACTICES, CONSTRUCTION CONTRACTOR WILL BE REQUIRED TO ASSUME SOLE AND COMPLETE RESPONSIBILITY FOR JOB SITE CONDITIONS DURING THE COURSE OF CONSTRUCTION OF THE PROJECT, INCLUDING THE SAFETY OF ALL PERSONS AND PROPERTY, THAT THIS REQUIREMENT SHALL BE MADE TO APPLY CONTINUOUSLY AND NOT TO BE LIMITED TO NORMAL WORKING HOURS, AND CONSTRUCTION CONTRACTOR FURTHER AGREES TO DEFEND, INDEMNIFY, AND HOLD DESIGN PROFESSIONAL HARMLESS FROM ANY LIABILITY, REAL OR ALLEGED, IN CONNECTION WITH THE PERFORMANCE OF WORK ON THIS PROJECT, EXCEPTING LIABILITY ARISING FROM THE SOLE NEGLIGENCE OF DESIGN PROFESSIONAL.
- THE ENGINEER PREPARING THESE PLANS WILL NOT BE RESPONSIBLE FOR, OR LIABLE FOR, UNAUTHORIZED USE OF THESE PLANS. ALL CHANGES TO THE PLANS MUST BE IN WRITING AND MUST BE APPROVED BY THE PREPARER OF THESE PLANS.

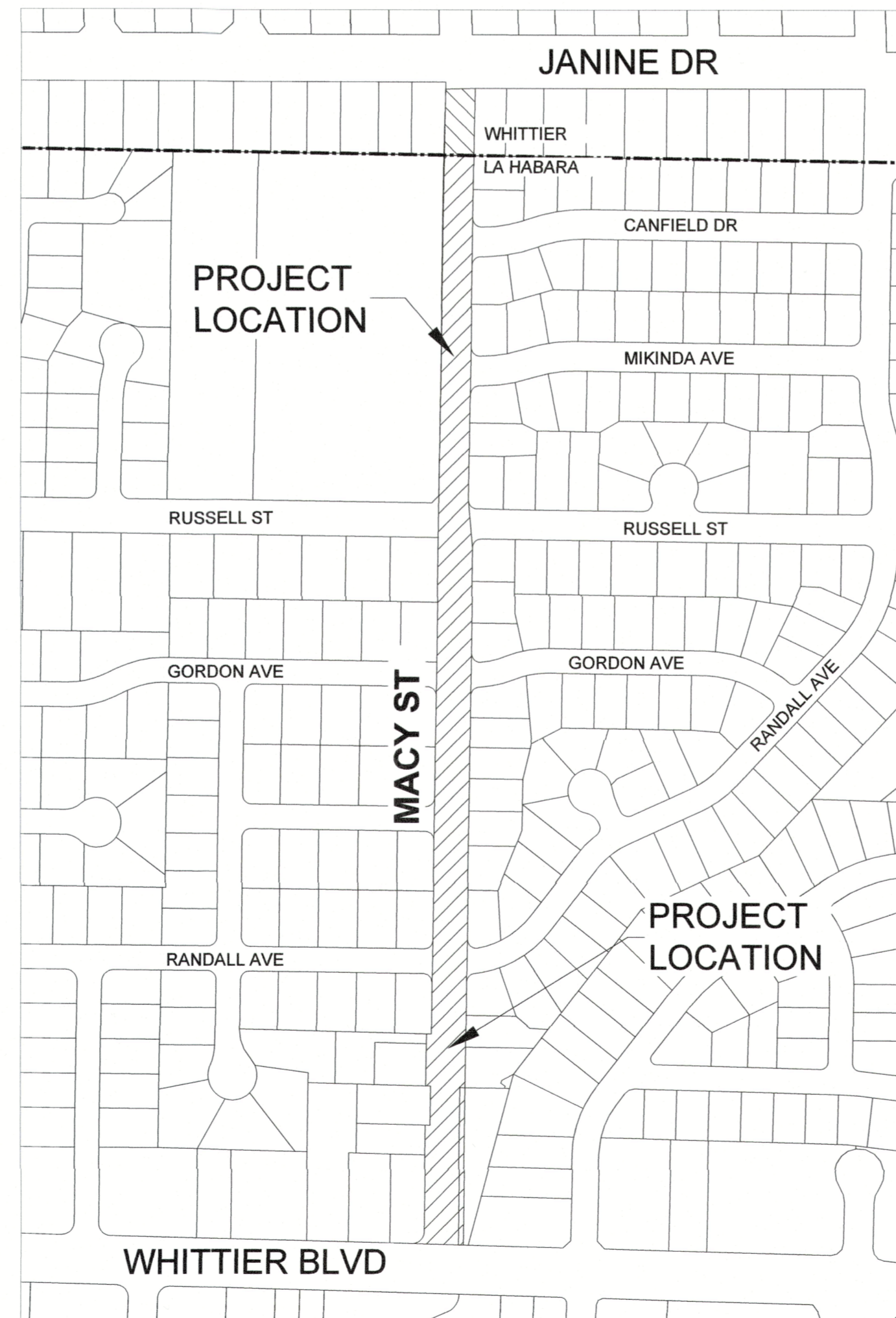

PROJECT LOCATION MAP
N.T.S.

GENERAL NOTES

- ALL WORK SHALL CONFORM TO THE LATEST EDITION OF THE STANDARD SPECIFICATIONS FOR PUBLIC WORKS CONSTRUCTION (GREEN BOOK), CALIFORNIA DEPARTMENT OF TRANSPORTATION STANDARD PLANS & SPECIFICATIONS, CITY OF LA HABRA STANDARD PLANS, AND PROJECT SPECIAL PROVISIONS, EACH OF THE MOST RECENT DATE.
- THE CONTRACTOR SHALL OBTAIN ALL NECESSARY PERMITS AND NOTIFY THE CITY OF LA HABRA AT LEAST TWO WORKING DAYS (48 HOURS) PRIOR TO STARTING CONSTRUCTION.
- TRAFFIC CONTROL AND SAFETY DEVICES SHALL BE INSTALLED PER THE STATE OF CALIFORNIA MANUAL OF UNIFORM TRAFFIC CONTROL DEVICES (CA MUTCD), AND TO THE SATISFACTION OF THE CITY INSPECTOR.
- IT SHALL BE THE CONTRACTOR'S RESPONSIBILITY TO ARRANGE FOR AND COORDINATE THE RELOCATION OF ANY EXISTING UTILITIES DEEMED NECESSARY BY THE PROPOSED IMPROVEMENTS.
- THE CONTRACTOR SHALL BE RESPONSIBLE FOR PROTECTION OF ALL EXISTING UTILITIES. ANY DAMAGE TO SUCH FACILITIES CAUSED BY HIS WORK SHALL BE REPAIRED BY THE CONTRACTOR AT HIS EXPENSE.
- THE CONTRACTOR SHALL MAINTAIN ADJACENT STREETS AND ALLEYS IN A NEAT, CLEAN, DUST FREE AND SANITARY CONDITION TO THE SATISFACTION OF THE CITY'S INSPECTOR. THE ADJACENT STREETS AND ALLEYS SHALL BE KEPT CLEAN OF DEBRIS, WITH DUST AND OTHER NUISANCES BEING CONTROLLED AT ALL TIMES. THE CONTRACTOR SHALL BE RESPONSIBLE FOR ANY CLEAN UP ON ADJACENT STREETS AND ALLEYS AFFECTED BY HIS CONSTRUCTION. STOCKPILING OF MATERIALS WITHIN THE PUBLIC RIGHT-OF-WAY IS NOT ALLOWED WITHOUT PRIOR WRITTEN APPROVAL OF THE CITY ENGINEER.
- NEW CONCRETE SHALL MATCH EXISTING CONCRETE IN COLOR, FINISH, AND TEXTURE, TO THE APPROVAL OF THE CITY ENGINEER.
- CONTRACTOR SHALL OBTAIN ALL REQUIRED O.S.H.A. PERMITS PRIOR TO CONSTRUCTION OF UNDERGROUND FACILITIES.
- ACCESS RAMPS, DRIVEWAY APRONS, SLABS, WALLS, FENCES, CURBS, OR GUTTERS DISTURBED BY CONSTRUCTION SHALL BE REPLACED.
- ALL SAWCUTS SHALL BE DONE BY THE WET-CUT METHOD, UNLESS OTHERWISE APPROVED BY THE CITY ENGINEER, AND ALL SLURRY SHALL BE VACUUM REMOVED.
- THE CONTRACTOR SHALL UTILIZE BEST MANAGEMENT PRACTICES FOR THE CONTROL OF EROSION AND RUNOFF, AND PROTECTION OF EXISTING STORM DRAIN FACILITIES.
- PLACEMENT AND SCHEDULING OF PAVEMENT MARKINGS AND STRIPING SHOULD BE DETERMINED BY THE CITY ENGINEER.
- STRICT ADHERENCE TO DUST CONTROL REQUIREMENTS SHALL BE ENFORCED AND ALL DUST SHALL BE CONTROLLED BY WATERING UNLESS OTHERWISE APPROVED BY THE ENGINEER.
- PRIOR TO TAKING ANY WATER FROM A FIRE HYDRANT, THE CONTRACTOR SHALL MAKE ARRANGEMENTS TO OBTAIN A FIRE HYDRANT METER.
- ALL SURVEY MONUMENTS SHALL BE PROTECTED AND PERPETUATED IN PLACE. ANY DISTURBED OR COVERED MONUMENTS SHALL BE RESET BY A QUALIFIED REGISTERED CIVIL ENGINEER OR LICENSED LAND SURVEYOR.
- ANY CONTRACTOR PERFORMING WORK ON THIS PROJECT SHALL VISIT THE LOCATION OF WORK, FAMILIARIZE THEMSELVES WITH THE WORK SITE, SLOPES, LANDSCAPING AND STRUCTURES AND SHALL BE SOLELY RESPONSIBLE FOR ANY DAMAGE TO EXISTING FACILITIES RESULTING DIRECTLY OR INDIRECTLY FROM THEIR OPERATION WHETHER OR NOT SUCH FACILITIES ARE SHOWN ON THESE PLANS.
- TRAFFIC CONTROL PLAN TO BE APPROVED BY TRAFFIC MANAGER PRIOR TO START OF CONSTRUCTION ACTIVITY. (REQUIRED FOR PERMIT.)

STORMWATER PERMIT (NPDES REQUIREMENTS) NOTES:

- SEDIMENT FROM AREAS DISTURBED BY CONSTRUCTION SHALL BE RETAINED ON SITE USING STRUCTURAL CONTROLS AS REQUIRED BY THE STATEWIDE GENERAL CONSTRUCTION STORMWATER PERMIT.
- STOCKPILES OF SOIL SHALL BE PROPERLY CONTAINED TO ELIMINATE OR REDUCE SEDIMENT TRANSPORT FROM THE SITE TO STREETS, DRAINAGE FACILITIES OR ADJACENT PROPERTIES VIA RUNOFF, VEHICLE TRACKING, OR WIND AS REQUIRED BY THE STATEWIDE GENERAL CONSTRUCTION STORMWATER PERMIT.
- APPROPRIATE BMPs FOR CONSTRUCTION-RELATED MATERIALS, WASTES, SPILLS OR RESIDUES SHALL BE IMPLEMENTED TO ELIMINATE OR REDUCE TRANSPORT FROM THE SITE TO STREETS, DRAINAGE FACILITIES, OR ADJACENT PROPERTIES BY WIND OR RUNOFF AS REQUIRED BY THE STATEWIDE GENERAL CONSTRUCTION STORMWATER PERMIT.
- RUNOFF FROM EQUIPMENT AND VEHICLE WASHING SHALL BE CONTAINED AT CONSTRUCTION SITES AND MUST NOT BE DISCHARGED TO RECEIVING WATERS OR THE LOCAL STORM DRAIN SYSTEM.
- ALL PERSONNEL FROM THE CONSTRUCTION CONTRACTORS AND SUBCONTRACTOR'S PERSONNEL ARE TO BE MADE AWARE OF THE REQUIRED BEST MANAGEMENT PRACTICES AND GOOD HOUSEKEEPING MEASURES FOR THE PROJECT SITE AND ANY ASSOCIATED CONSTRUCTION STAGING AREAS.
- AT THE END OF EACH DAY OF CONSTRUCTION ACTIVITY ALL CONSTRUCTION DEBRIS AND WASTE MATERIALS SHALL BE COLLECTED AND PROPERLY DISPOSED IN TRASH OR RECYCLE BINS.
- CONSTRUCTION SITES SHALL BE MAINTAINED IN SUCH A CONDITION THAT A STORM DOES NOT CARRY WASTES OR POLLUTANTS OFF THE SITE. DISCHARGES OTHER THAN STORMWATER (NON-STORMWATER DISCHARGES) ARE PROHIBITED, EXCEPT AS AUTHORIZED BY AN INDIVIDUAL NPDES PERMIT OR THE STATEWIDE GENERAL CONSTRUCTION STORMWATER PERMIT. POTENTIAL POLLUTANTS INCLUDE BUT ARE NOT LIMITED TO: SOLID OR LIQUID CHEMICAL SPILLS; WASTES FROM PAINTS, STAINS, SEALANTS, SOLVENTS, DETERGENTS, GLUES, LIME, PESTICIDES, HERBICIDES, FERTILIZERS, WOOD PRESERVATIVES, AND ASBESTOS FIBERS; PAINT FLAKES OR STUCCO FRAGMENTS; FUELS, OILS, LUBRICANTS, AND HYDRAULIC, RADIATOR OR BATTERY FLUIDS; CONCRETE AND RELATED CUTTING OR CURING RESIDUES; FLOATABLE WASTES; WASTES FROM ENGINE/EQUIPMENT STEAM CLEANING OR CHEMICAL DEGREASING; WASTES FROM STREET CLEANING; AND SUPER-CHLORINATED POTABLE WATER FROM LINE FLUSHING AND TESTING.
- DURING CONSTRUCTION, DISPOSAL OF SUCH MATERIALS SHOULD OCCUR IN A SPECIFIED AND CONTROLLED TEMPORARY AREA ON-SITE PHYSICALLY SEPARATED FROM POTENTIAL STORMWATER RUNOFF, WITH ULTIMATE DISPOSAL IN ACCORDANCE WITH LOCAL, STATE AND FEDERAL REQUIREMENTS. DISCHARGING CONTAMINATED GROUNDWATER PRODUCED BY DEWATERING GROUNDWATER THAT HAS INFILTRATED INTO THE CONSTRUCTION SITE IS PROHIBITED. DISCHARGING OF CONTAMINATED SOILS VIA SURFACE EROSION IS ALSO PROHIBITED.
- DISCHARGING NON-CONTAMINATED GROUNDWATER PRODUCED BY DEWATERING ACTIVITIES REQUIRES A NATIONAL POLLUTANT DISCHARGE ELIMINATION SYSTEM (NPDES) PERMIT FROM THE RESPECTIVE STATE REGIONAL WATER QUALITY CONTROL BOARD.

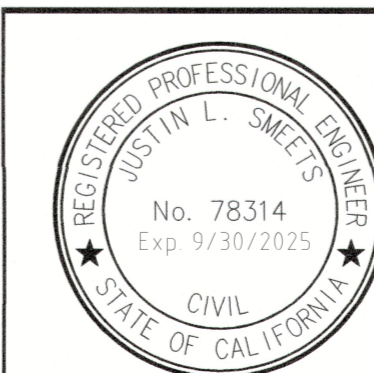
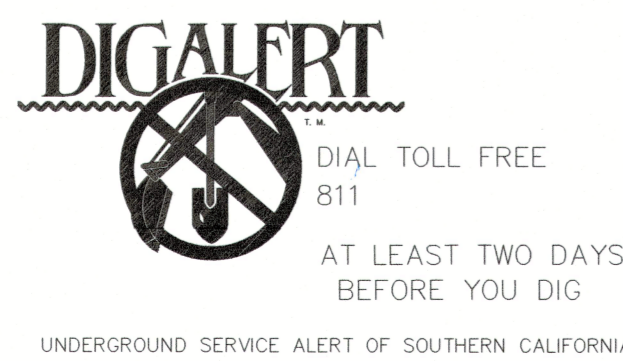

REVISION		CITY OF LA HABRA	
NO.	DATE	DESCRIPTION	BY

MACY STREET REHABILITATION PROJECT WHITTIER BLVD. TO JANINE DR. TITLE SHEET		
DESIGNED BY: <i>Justin Smeets</i> JUSTIN SMEETS, P.E., PROJECT MANAGER	CITY ENGINEER: <i>Albert Mendoza</i> ALBERT MENDOZA, P.E. 60382	PROJECT NO. 1-R-23
DATE: DECEMBER 20, 2024	DATE: <i>2.2025</i>	SHEET 01 of 11

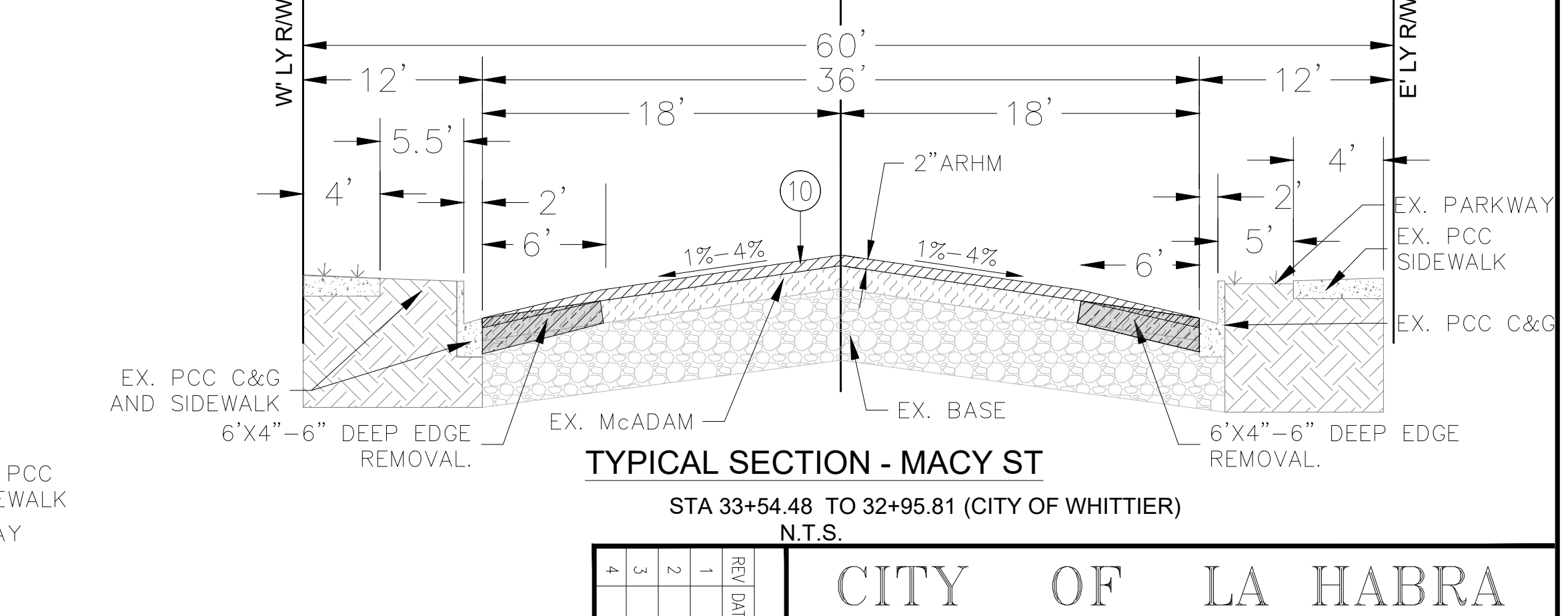
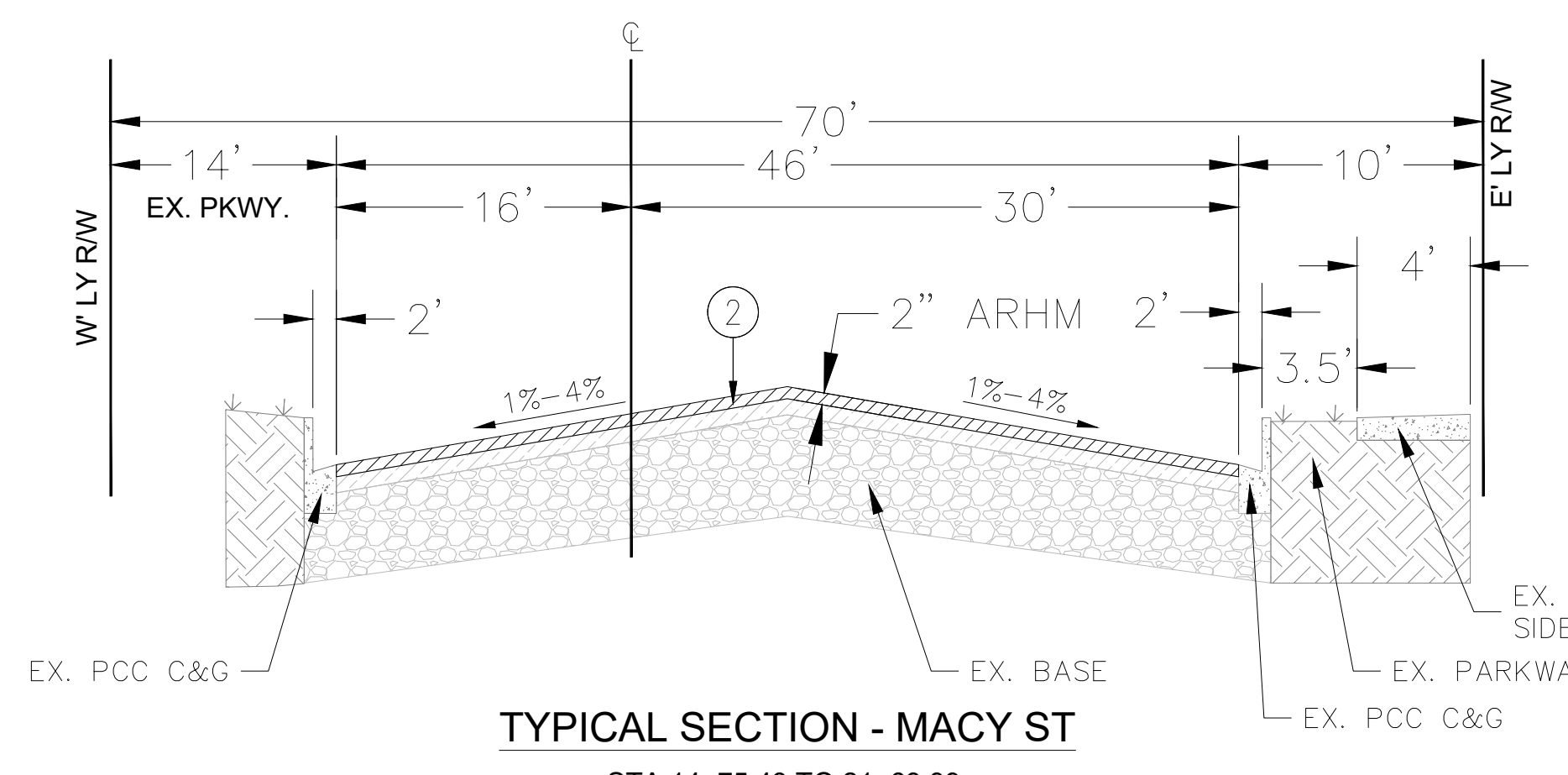
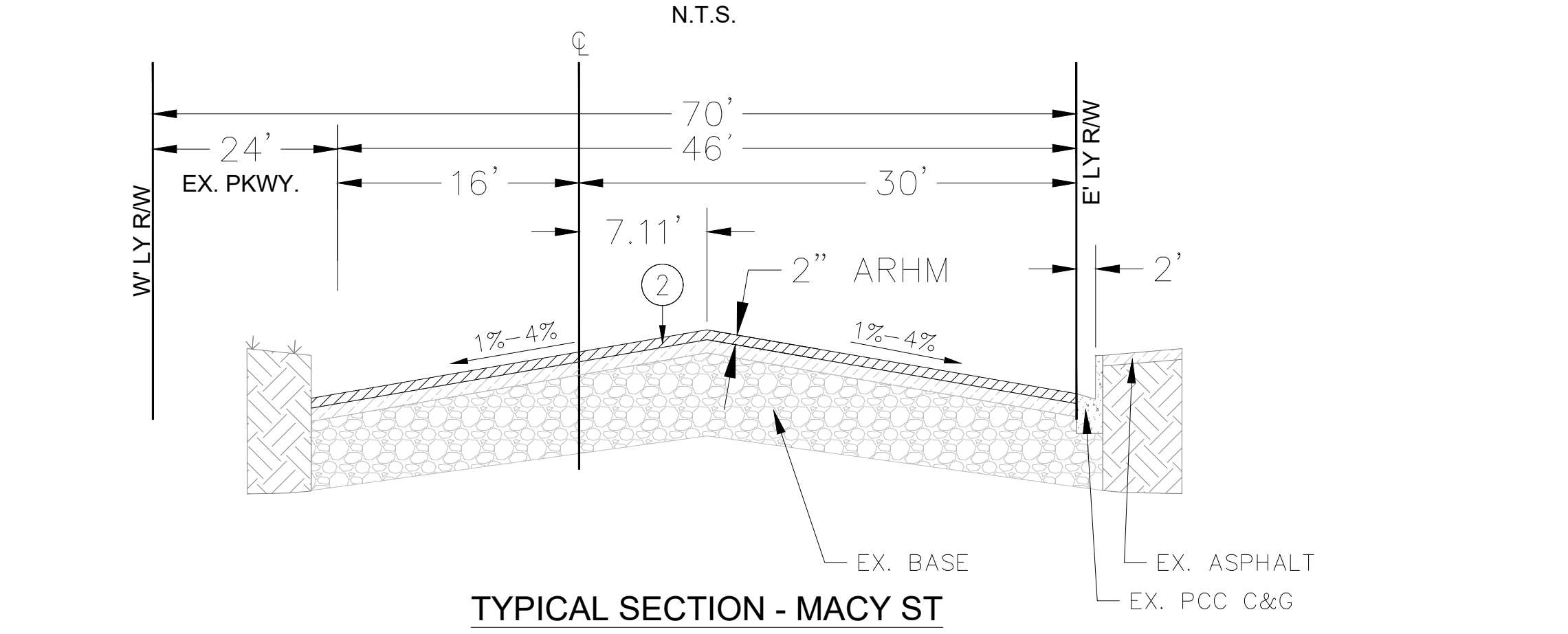
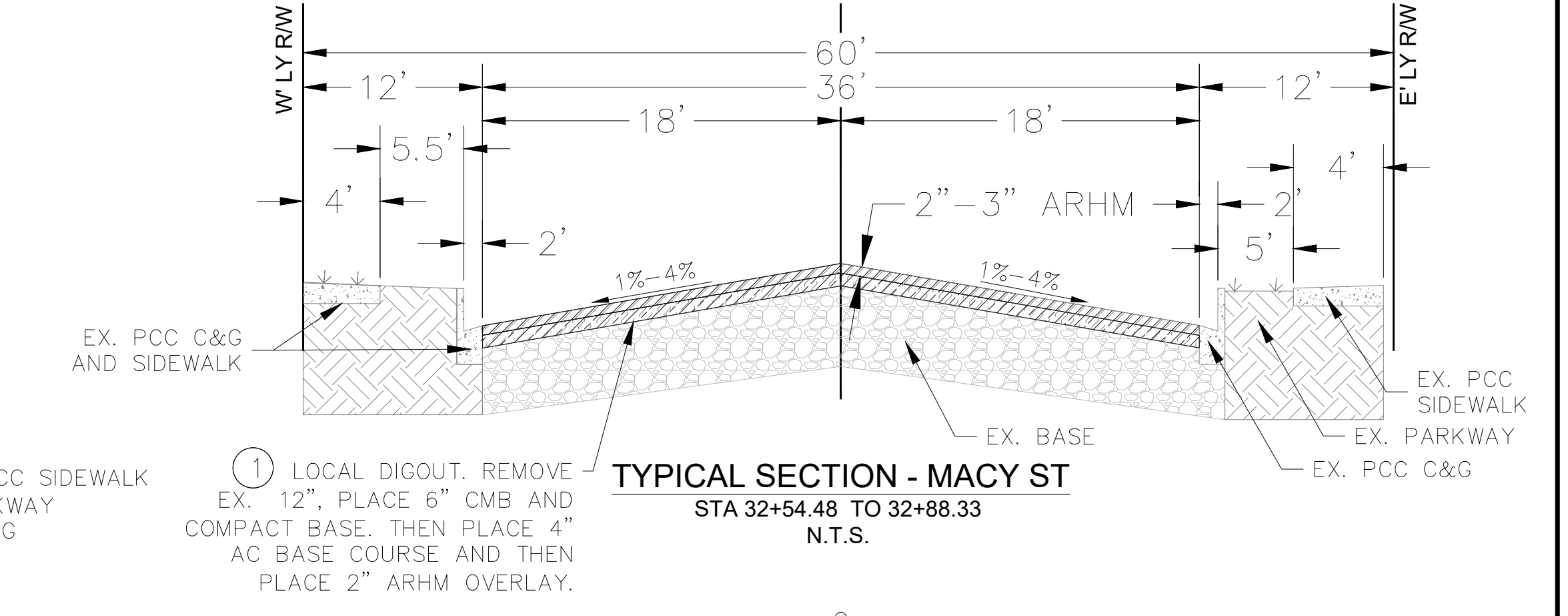
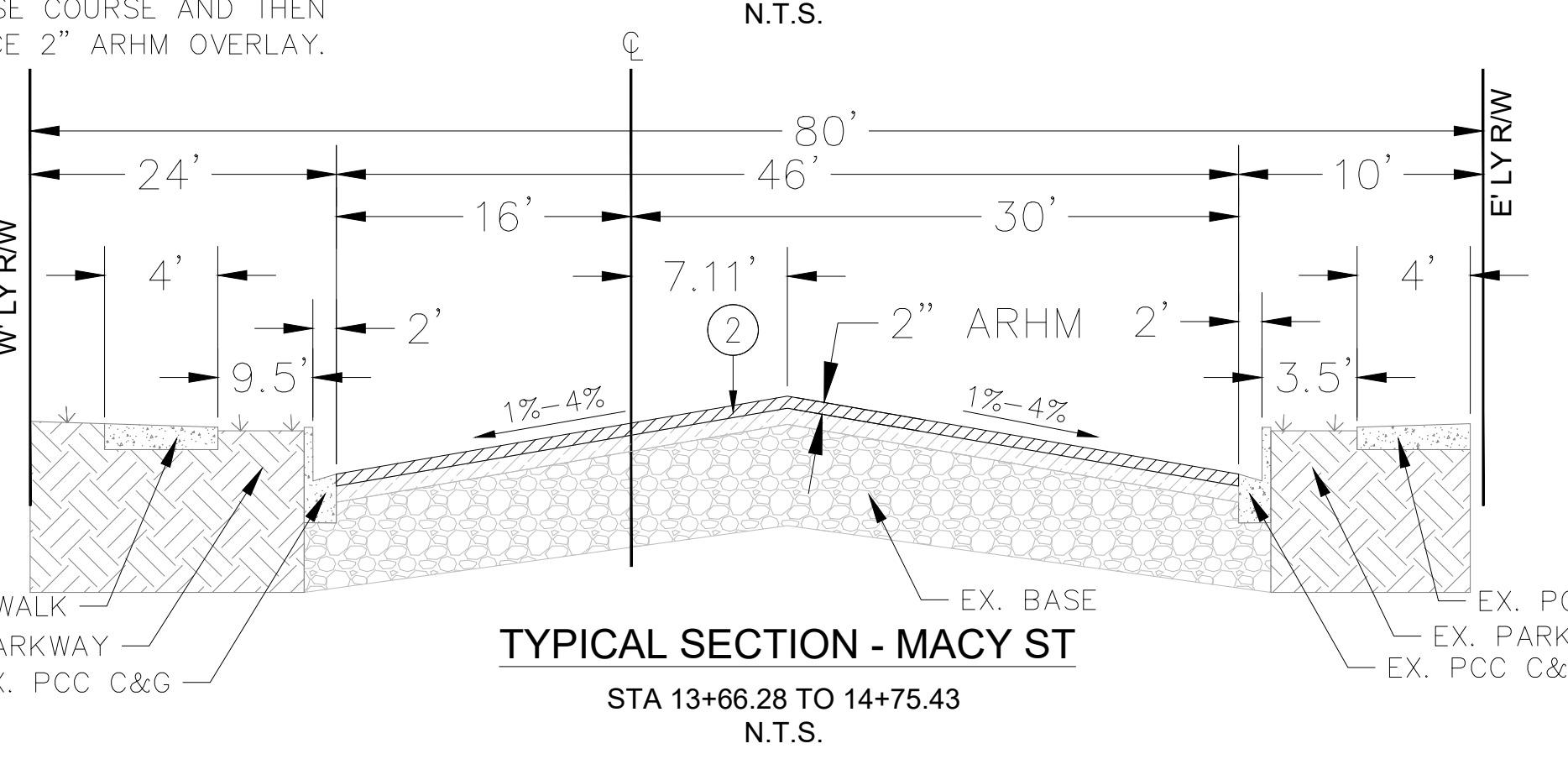
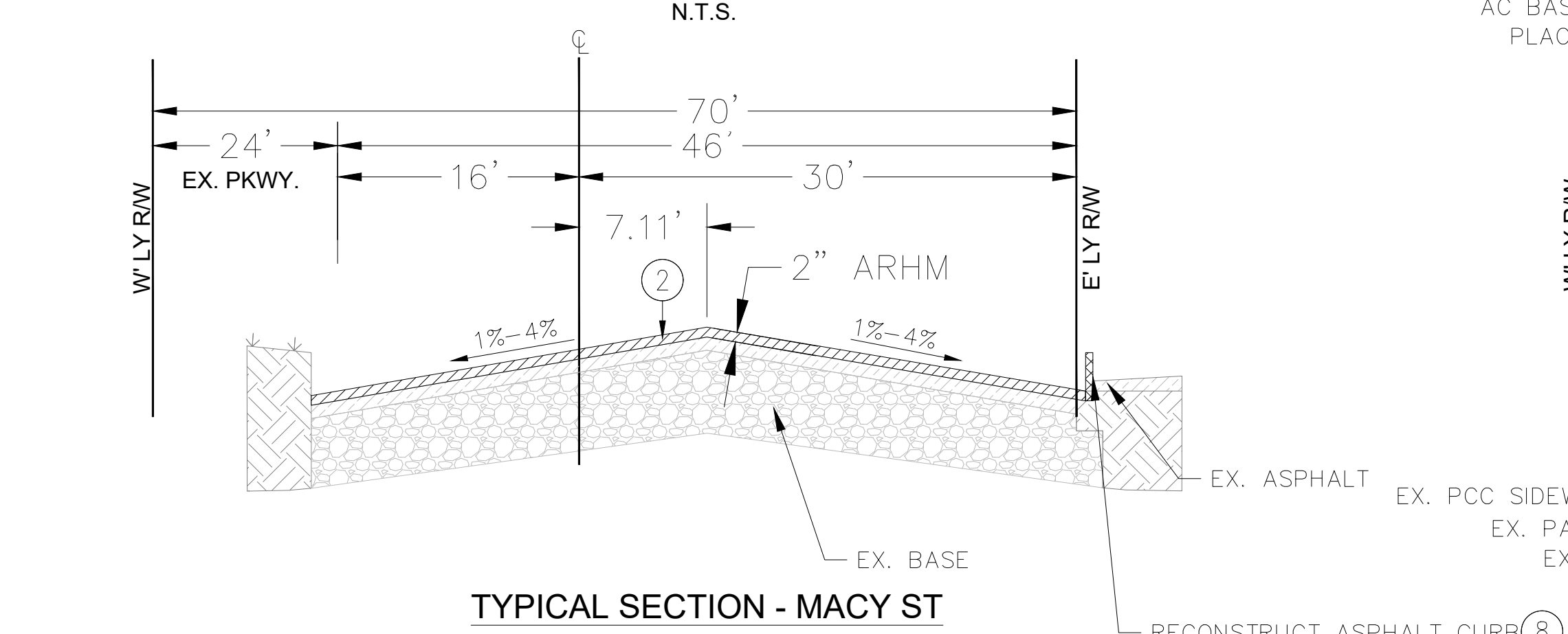
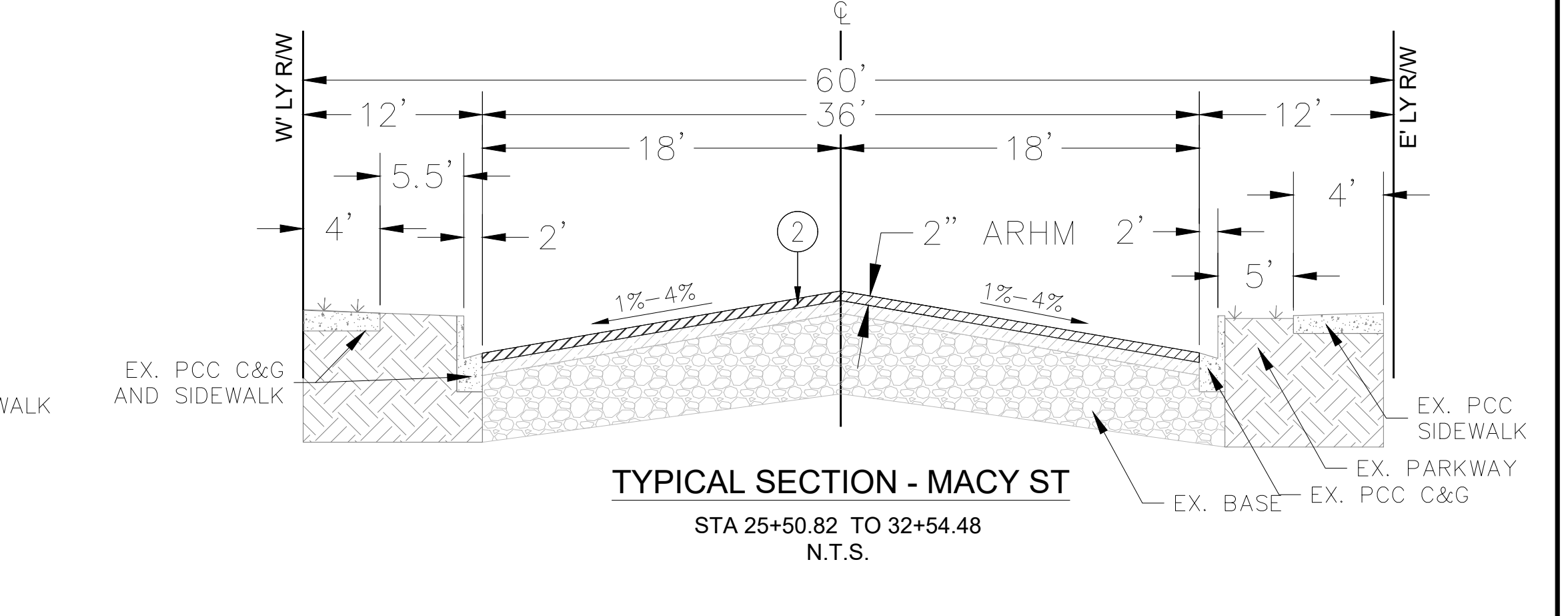
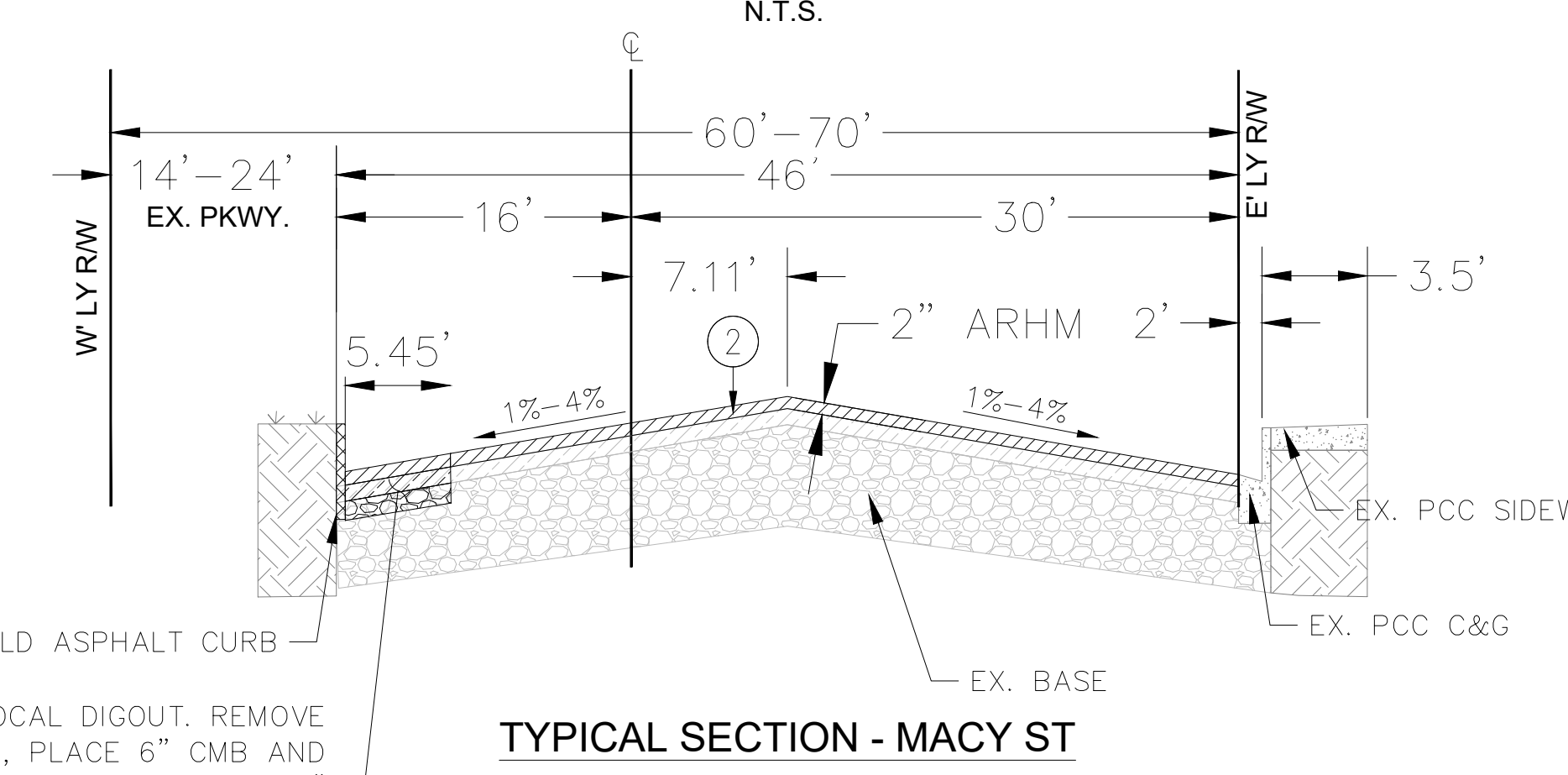
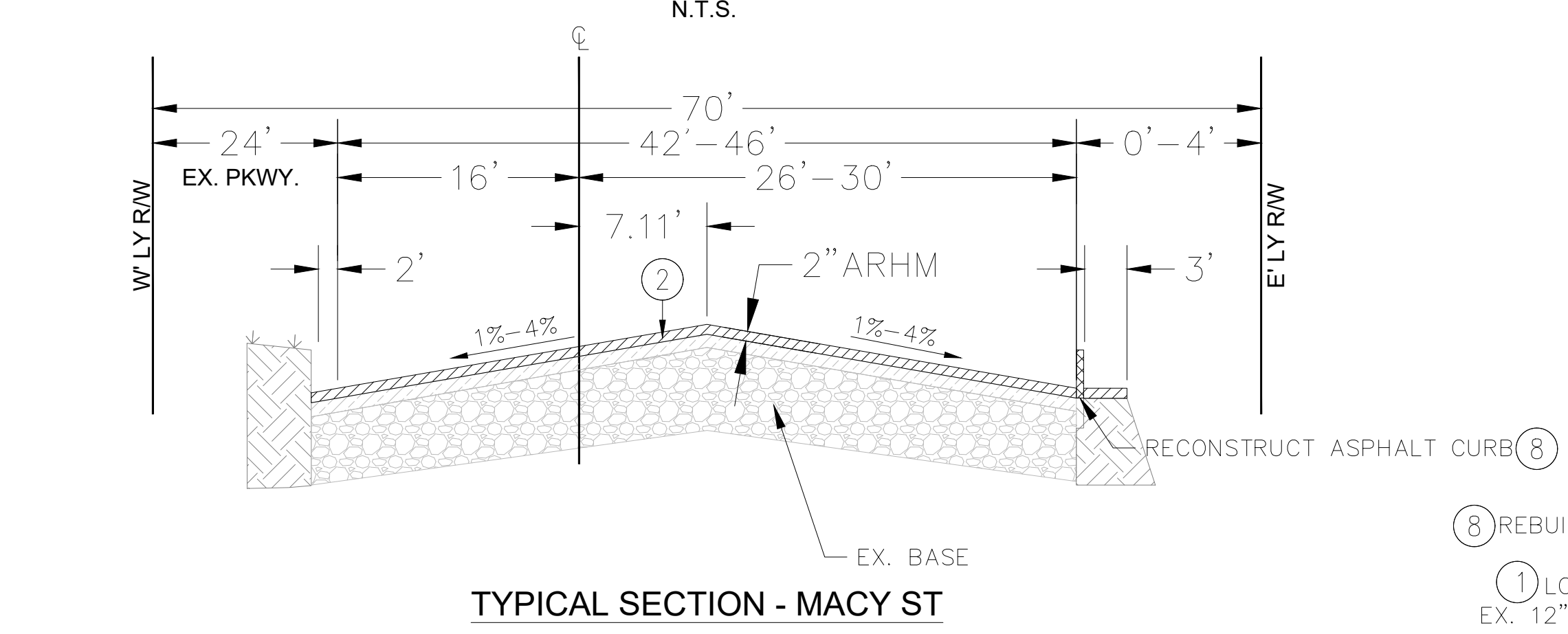
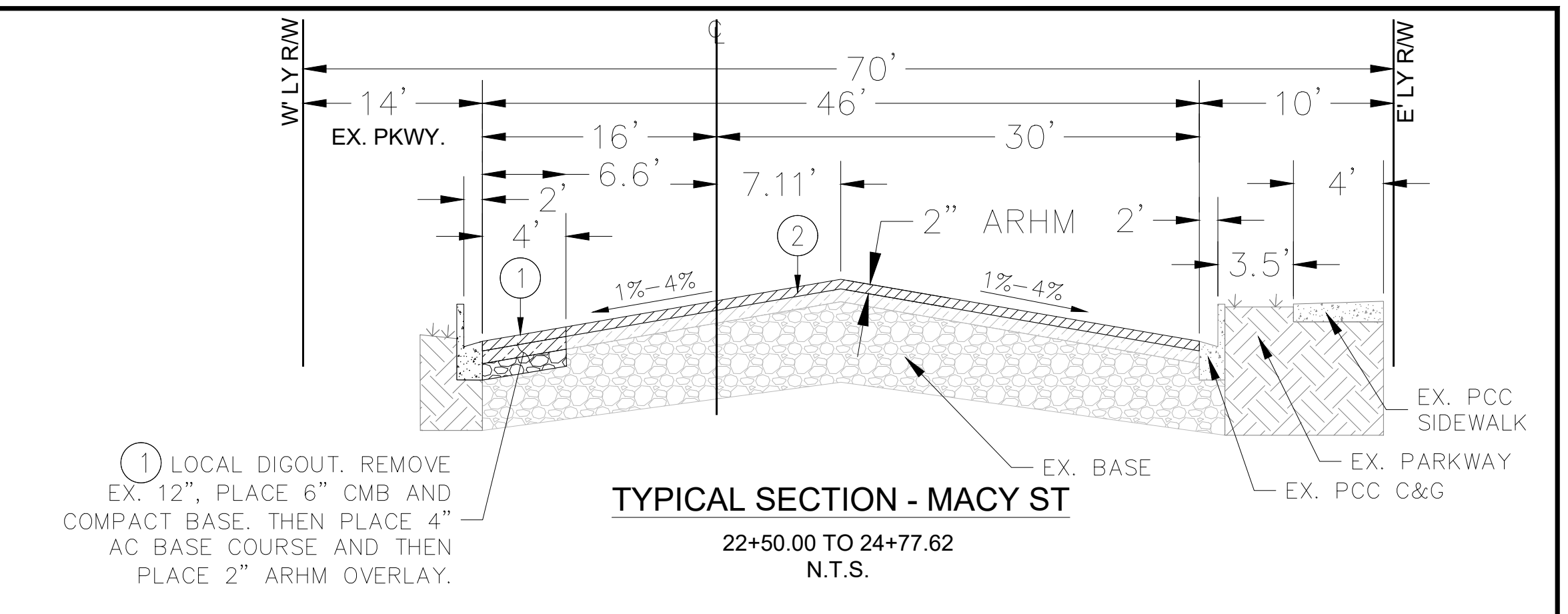
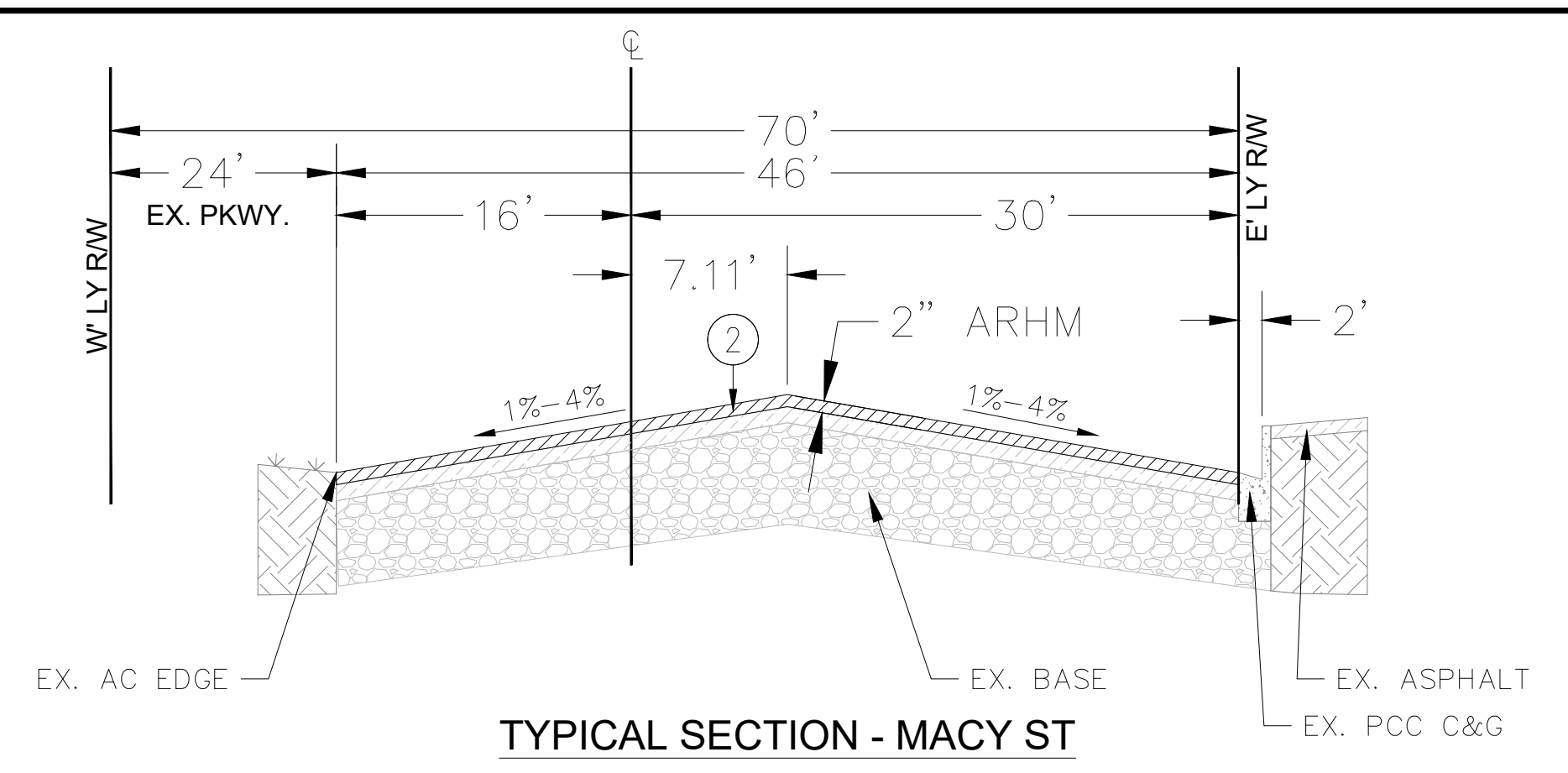
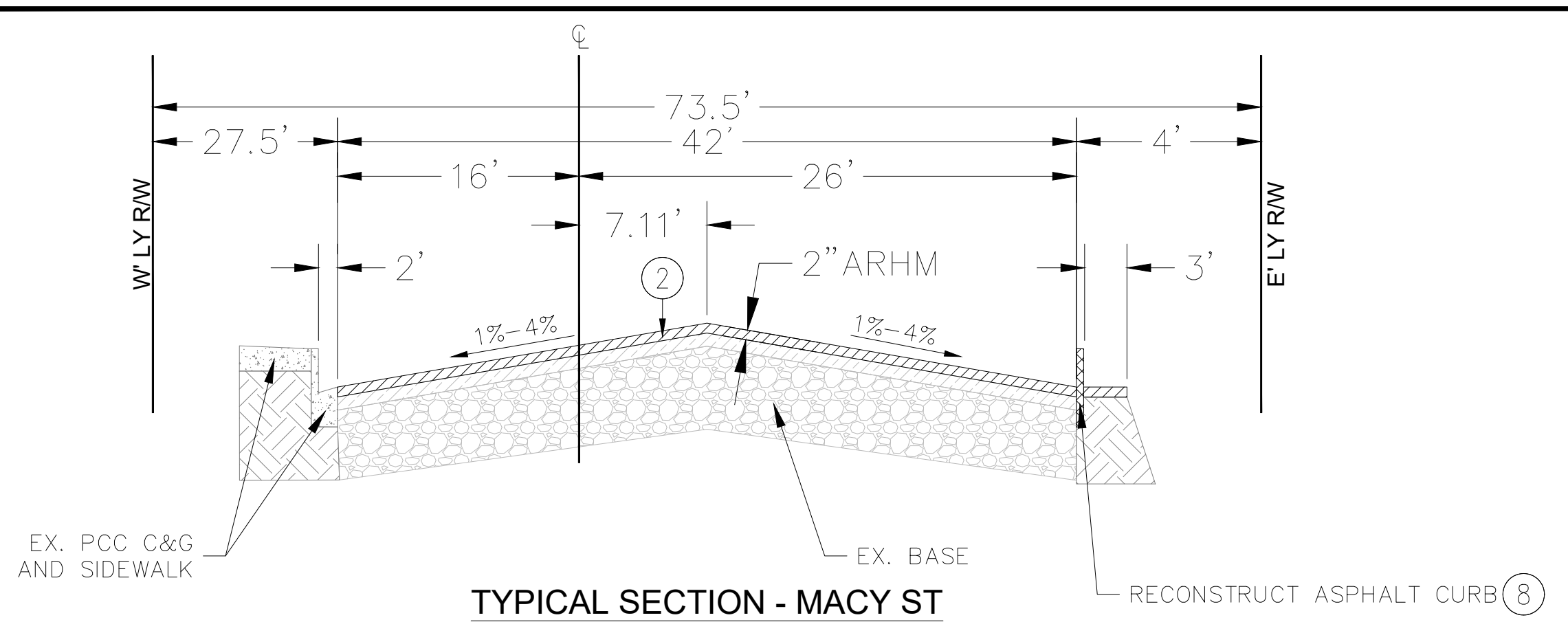

- CONSTRUCTION NOTES**
- ① LOCALIZED DIGOUTS - REMOVE EXISTING 12", PLACE 6" CMB AND COMPACT BASE. THEN PLACE 4" AC BASE COURSE AND THEN PLACE 2" ARHM OVERLAY.
 - ② 2" COLD MILL AND PLACE 2" THICK ARHM WEARING COURSE.
 - ⑧ RECONSTRUCT AC CURB PER SPPWC 120-3 TYPE D1-8 (200).
 - ⑩ 6' WIDE, 6"-4" MACADAM EDGE EXCAVATION, PLACE 4" AC BASE COURSE AND 2" ARHM OVERLAY PER TYPICAL SECTION ON SHEET 2.

LEGEND

	PROPOSED CONCRETE IMPROVEMENTS		EXISTING CONCRETE
	PROPOSED AC CURB		EXISTING AC PAVEMENT
	PROPOSED OVERLAY		EXISTING AGGREGATE BASE
	PROPOSED AC BASE COURSE		EXISTING PARKWAY
	PROPOSED CMB		EXISTING MACADAM
	REMOVE		

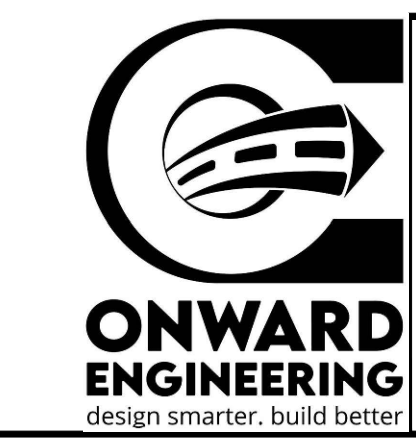

CITY OF LA HABRA
MACY STREET REHABILITATION PROJECT
WHITTIER BLVD. TO JANINE DR.
TYPICAL SECTIONS

DESIGNED BY: <i>Justin Smets</i>	PROJECT NO. 1-R-23
DATE: DECEMBER 20, 2024	SHEET 02 OF 11

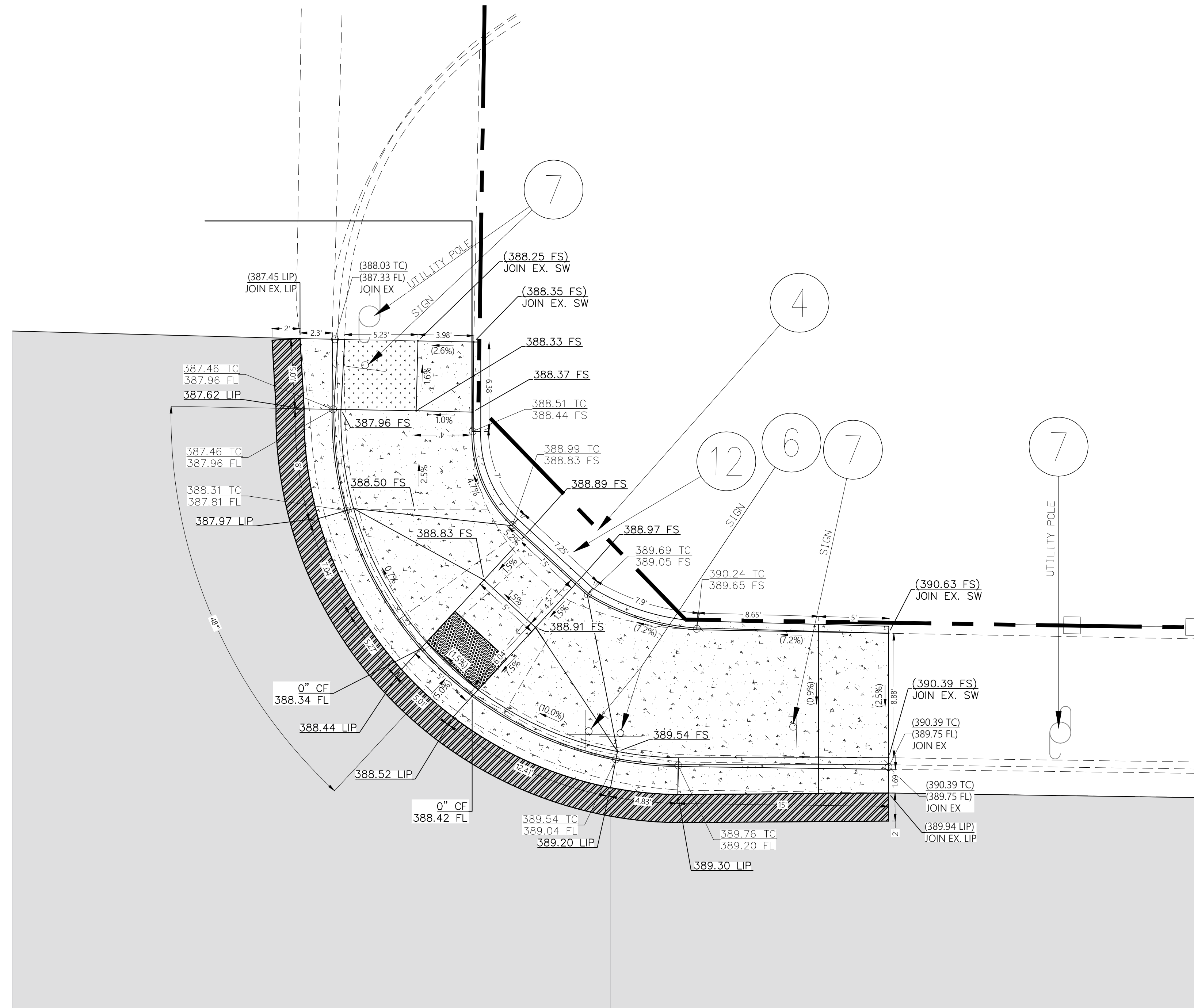

CURB RAMP DETAIL #1

SCALE: 1" = 5'



CONSTRUCTION NOTES

- ④ INSTALL NEW ADA RAMP PER CURB RAMP DETAIL 1.
- ⑥ REMOVE POST, PATCH CONCRETE, RELOCATE SIGNS ON NEW TELESPAR POST.
- ⑦ PROTECT IN PLACE AS NOTED ON PLAN.
- ⑫ CONSTRUCT NEW VARIABLE HEIGHT RETAINING CURB.

LEGEND

- PROPOSED CONCRETE IMPROVEMENTS.
- PROPOSED DETECTABLE WARNING SURFACE.
- 6" FULL DEPTH AC SLOT CUT.

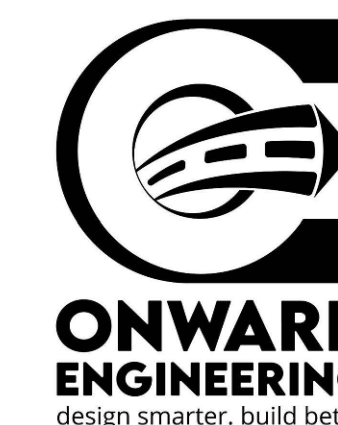

REVISION		CITY OF LA HABRA	
4			MACY STREET REHABILITATION PROJECT WHITTIER BLVD. TO JANINE DR. DETAILS
3			
2			
1			
DESIGNED BY:	<i>Justin Smeets</i>	PROJECT NO.	1-R-23
DATE	DECEMBER 20, 2024	SHEET	03 of 11

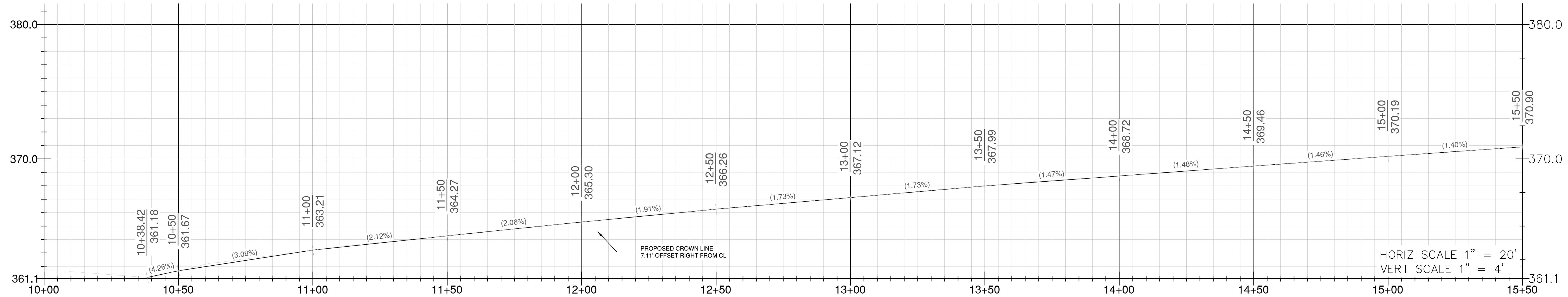

HORIZ SCALE 1" = 20'
VERT SCALE 1" = 4'

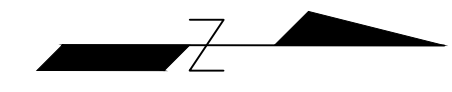
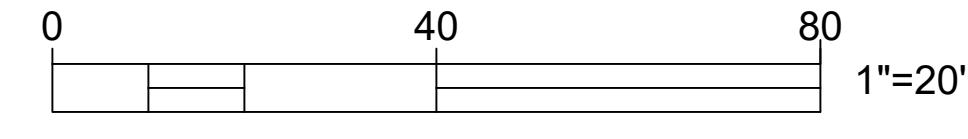
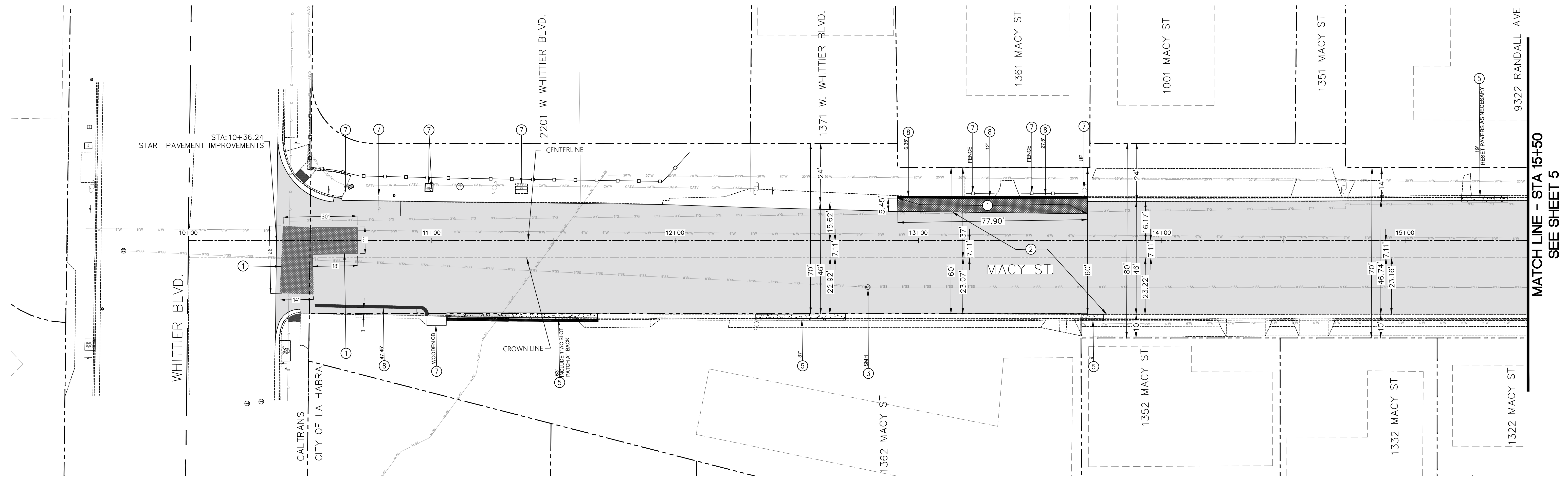

CONSTRUCTION NOTES

- ① LOCALIZED DIGOUTS - REMOVE EXISTING 12", PLACE 6" CMB AND COMPACT BASE. THEN PLACE 4" AC BASE COURSE AND THEN PLACE 2" ARHM OVERLAY.
- ② 2" COLD MILL AND PLACE 2" THICK ARHM WEARING COURSE.
- ③ ADJUST TO GRADE ITEM AS NOTED ON PLAN.
- ⑤ INSTALL NEW CURB AND GUTTER PER SPPWC 120-3 TYPE A2, VARIABLE HEIGHT CURB FACE, OVER 6" CMB
- ⑦ PROTECT IN PLACE AS NOTED ON PLAN.
- ⑧ RECONSTRUCT AC CURB PER SPPWC 120-3 TYPE D1-8 (200).

LEGEND

- LOCALIZED DIGOUTS - REMOVE EXISTING 12", PLACE 6" CMB AND COMPACT BASE. THEN PLACE 4" AC BASE COURSE AND THEN PLACE 2" ARHM OVERLAY.
- 2" COLD MILL AND PLACE 2" THICK ARHM WEARING COURSE.
- PCC IMPROVEMENTS.

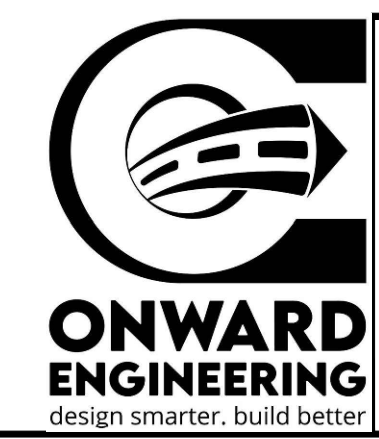

REV	DATE	DESCRIPTION	BY
1			
2			
3			
4			

CITY OF LA HABRA
MACY STREET REHABILITATION PROJECT
WHITTIER BLVD. TO JANINE DR.
PAVEMENT IMPROVEMENTS

DESIGNED BY: *Justin Smeets*
JUSTIN SMEETS, P.E., PROJECT MANAGER
DATE: DECEMBER 20, 2024

PROJECT NO.
1-R-23
SHEET 04 OF 11

MATCH LINE - STA 15+50
SEE SHEET 5

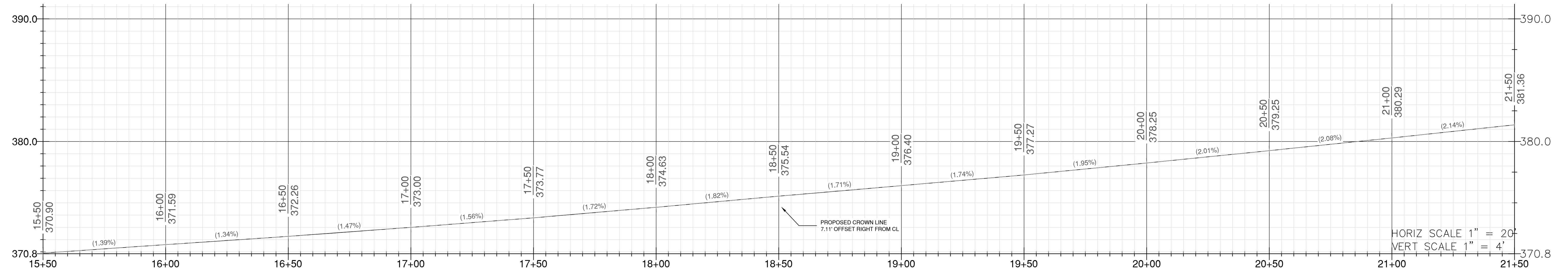

HORIZ SCALE 1" = 20'
VERT SCALE 1" = 4'

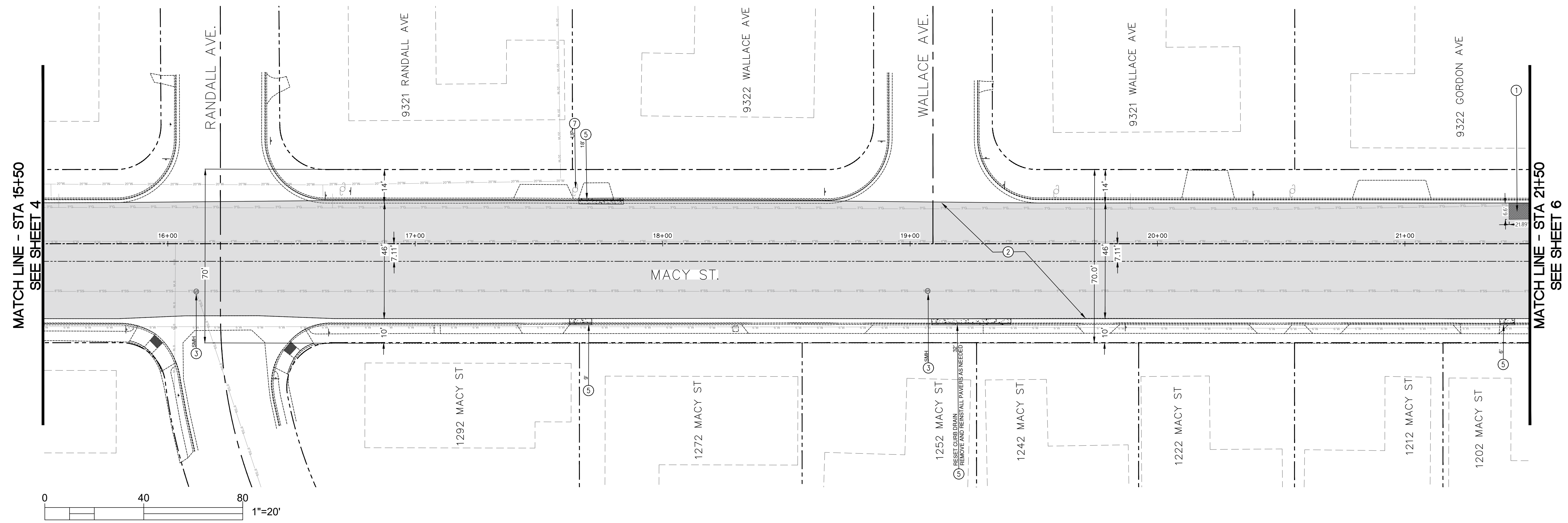

MATCH LINE - STA 15+50
SEE SHEET 4

MATCH LINE - STA 21+50
SEE SHEET 6

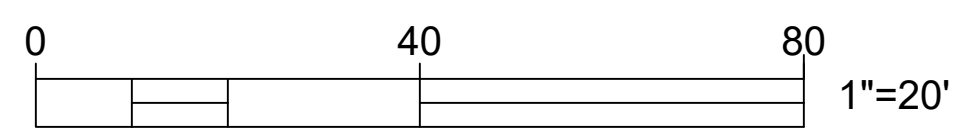

CONSTRUCTION NOTES

- ① LOCALIZED DIGOUTS - REMOVE EXISTING 12", PLACE 6" CMB AND COMPACT BASE. THEN PLACE 4" AC BASE COURSE AND THEN PLACE 2" ARHM OVERLAY.
- ② 2" COLD MILL AND PLACE 2" THICK ARHM WEARING COURSE.
- ③ ADJUST TO GRADE ITEM AS NOTED ON PLAN.
- ⑤ INSTALL NEW CURB AND GUTTER PER SPPWC 120-3 TYPE A2, VARIABLE HEIGHT CURB FACE, OVER 6" CMB
- ⑦ PROTECT IN PLACE AS NOTED ON PLAN.

LEGEND

- LOCALIZED DIGOUTS - REMOVE EXISTING 12", PLACE 6" CMB AND COMPACT BASE. THEN PLACE 4" AC BASE COURSE AND THEN PLACE 2" ARHM OVERLAY.
- 2" COLD MILL AND PLACE 2" THICK ARHM WEARING COURSE.
- CONCRETE IMPROVEMENTS

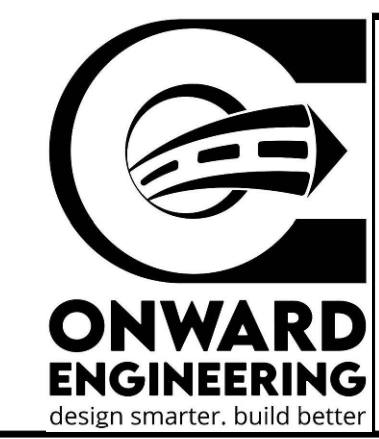

REVISION		CITY OF LA HABRA	
4		MACY STREET REHABILITATION PROJECT WHITTIER BLVD. TO JANINE DR. PAVEMENT IMPROVEMENTS	
3			
2			
1			
REV	DATE	DESIGNED BY:	PROJECT NO.
		<i>Justin Smeets</i>	1-R-23
		JUSTIN SMEETS, P.E., PROJECT MANAGER	SHEET 05 of 11
		DATE: DECEMBER 20, 2024	

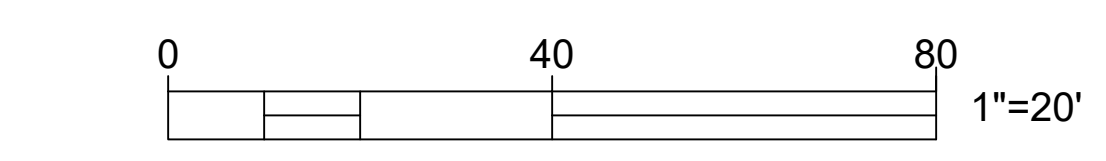
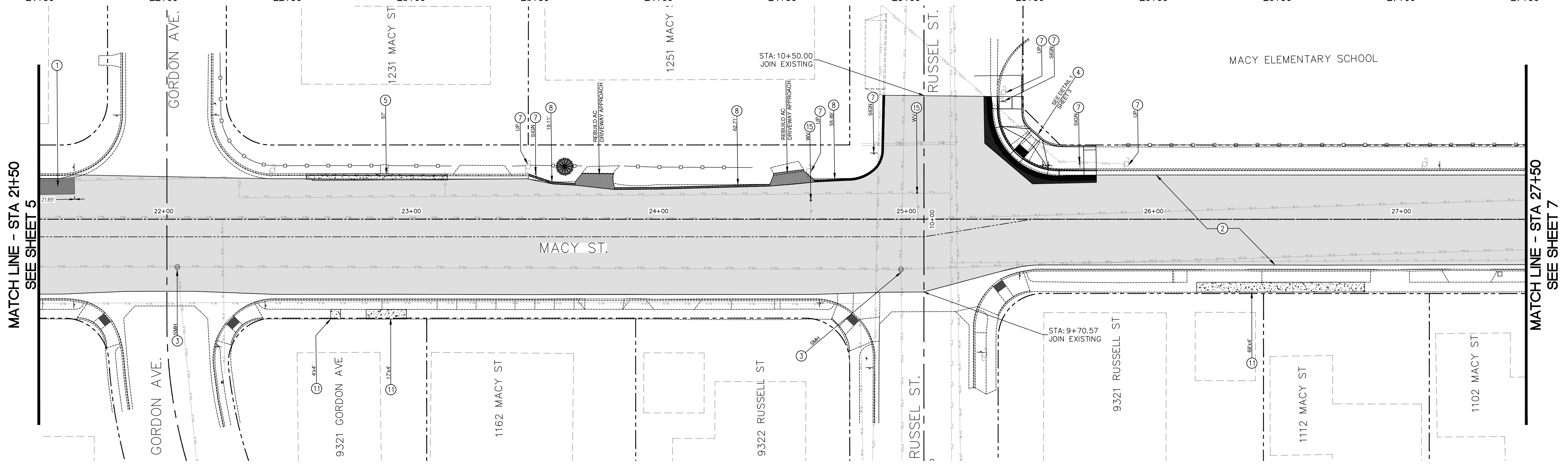
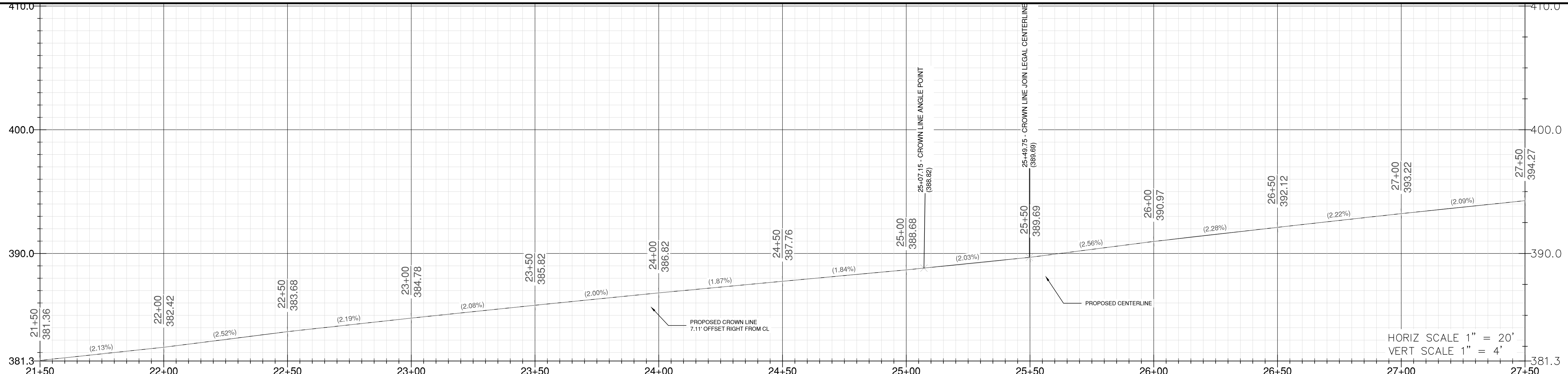

- CONSTRUCTION NOTES**
- ① LOCALIZED DIGOUTS - REMOVE EXISTING 12", PLACE 6" CMB AND COMPACT BASE. THEN PLACE 4" AC BASE COURSE AND THEN PLACE 2" ARHM OVERLAY.
 - ② 2" COLD MILL AND PLACE 2" THICK ARHM WEARING COURSE.
 - ③ ADJUST TO GRADE ITEM AS NOTED ON PLAN.
 - ④ INSTALL NEW ADA RAMP PER CURB RAMP DETAIL 1.
 - ⑤ INSTALL NEW CURB AND GUTTER PER SPPWC 120-3 TYPE A2, VARIABLE HEIGHT CURB FACE, OVER 6" CMB
 - ⑦ PROTECT IN PLACE AS NOTED ON PLAN.
 - ⑧ RECONSTRUCT AC CURB PER SPPWC 120-3 TYPE D1-8 (200).
 - ⑩ REMOVE EXISTING AND CONSTRUCT NEW SIDEWALK PER SPPWC STD. PLAN 113-2.
 - ⑫ ADJUST WATER VALVE CAN AND LID TO GRADE BY OTHERS

- LEGEND**
- LOCALIZED DIGOUTS - REMOVE EXISTING 12", PLACE 6" CMB AND COMPACT BASE. THEN PLACE 4" AC BASE COURSE AND THEN PLACE 2" ARHM OVERLAY.
 - 2" COLD MILL AND PLACE 2" THICK ARHM WEARING COURSE.
 - CONCRETE IMPROVEMENTS

HORIZ SCALE 1" = 20'
VERT SCALE 1" = 4'

MATCH LINE - STA 21+50
SEE SHEET 5

MATCH LINE - STA 27+50
SEE SHEET 7

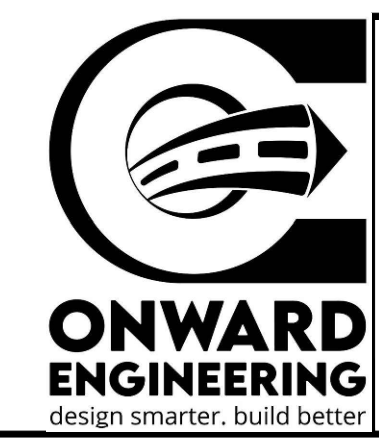

REV	DATE	DESCRIPTION	BY
1			
2			
3			
4			

CITY OF LA HABRA
MACY STREET REHABILITATION PROJECT
WHITTIER BLVD. TO JANINE DR.
PAVEMENT IMPROVEMENTS

DESIGNED BY: *Justin Smeets*
JUSTIN SMEETS, P.E., PROJECT MANAGER
DATE: DECEMBER 20, 2024

PROJECT NO.
1-R-23
SHEET 06 OF 11

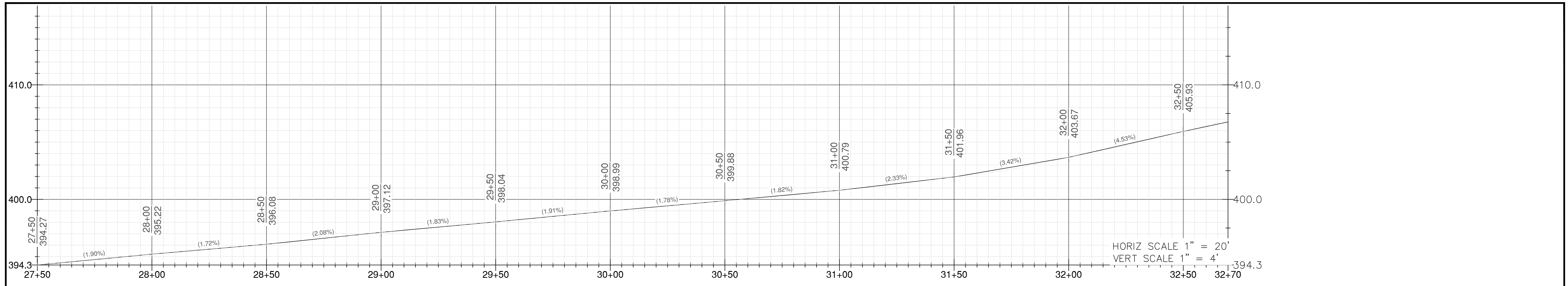

HORIZ SCALE 1" = 20'
VERT SCALE 1" = 4'

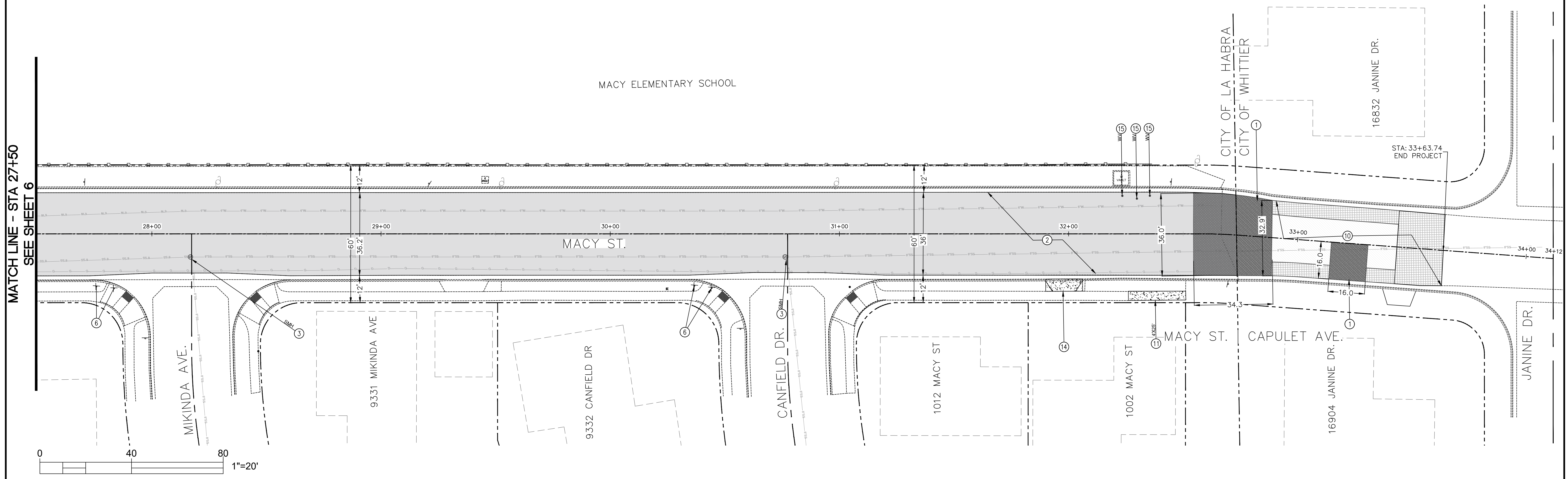

MATCH LINE - STA 27+50
SEE SHEET 6

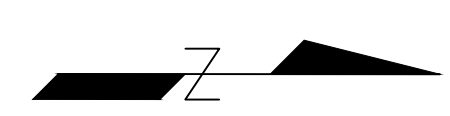
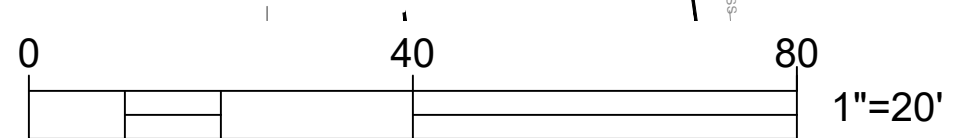

CONSTRUCTION NOTES

- ① LOCALIZED DIGOUTS - REMOVE EXISTING 12", PLACE 6" CMB AND COMPACT BASE. THEN PLACE 4" AC BASE COURSE AND THEN PLACE 2" ARHM OVERLAY.
- ② 2" COLD MILL AND PLACE 2" THICK ARHM WEARING COURSE.
- ③ ADJUST TO GRADE ITEM AS NOTED ON PLAN.
- ④ REMOVE POST, PATCH CONCRETE, RELOCATE SIGNS ON NEW TELESPAR POST.
- ⑩ 6' WIDE, 6"-4" MACADAM EDGE EXCAVATION, PLACE 4" AC BASE COURSE AND 2" ARHM OVERLAY PER TYPICAL SECTION ON SHEET 2.
- ⑪ REMOVE EXISTING AND CONSTRUCT NEW SIDEWALK PER SPPWC STD. PLAN 113-2.
- ⑭ REMOVE AND RECONSTRUCT PCC DRIVEWAY APPROACH PER SPPWC STD. PLAN 110-2 B.
- ⑮ ADJUST WATER VALVE CAN AND LID TO GRADE BY OTHERS

LEGEND

- ① LOCALIZED DIGOUTS - REMOVE EXISTING 12", PLACE 6" CMB AND COMPACT BASE. THEN PLACE 4" AC BASE COURSE AND THEN PLACE 2" ARHM OVERLAY.
- ⑩ 6' WIDE, 6"-4" MACADAM EDGE EXCAVATION, PLACE 4" AC BASE COURSE AND 2" ARHM OVERLAY PER TYPICAL SECTION ON SHEET 2.
- ② 2" COLD MILL AND PLACE 2" THICK ARHM WEARING COURSE.
- ③ 2" THICK ARHM WEARING COURSE.
- ④ CONCRETE IMPROVEMENTS

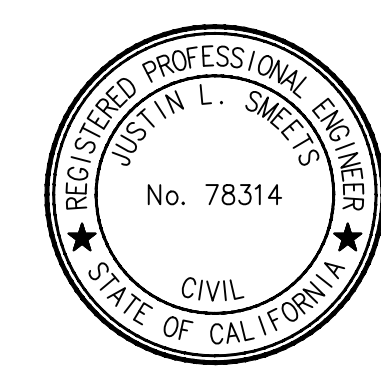
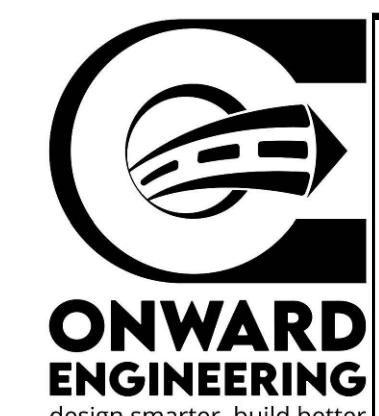

CITY OF LA HABRA																
MACY STREET REHABILITATION PROJECT																
WHITTIER BLVD. TO JANINE DR.																
PAVEMENT IMPROVEMENTS																
<table border="1" style="width: 100%; border-collapse: collapse;"> <thead> <tr> <th>REV</th> <th>DATE</th> <th>DESCRIPTION</th> </tr> </thead> <tbody> <tr> <td>1</td> <td></td> <td></td> </tr> <tr> <td>2</td> <td></td> <td></td> </tr> <tr> <td>3</td> <td></td> <td></td> </tr> <tr> <td>4</td> <td></td> <td></td> </tr> </tbody> </table>	REV	DATE	DESCRIPTION	1			2			3			4			<p>DESIGNED BY: <i>Justin Smeets</i></p> <p>JUSTIN SMEETS, P.E., PROJECT MANAGER</p> <p>DATE: DECEMBER 20, 2024</p>
REV	DATE	DESCRIPTION														
1																
2																
3																
4																
<p>PROJECT NO. 1-R-23</p> <p>SHEET 07 OF 11</p>																

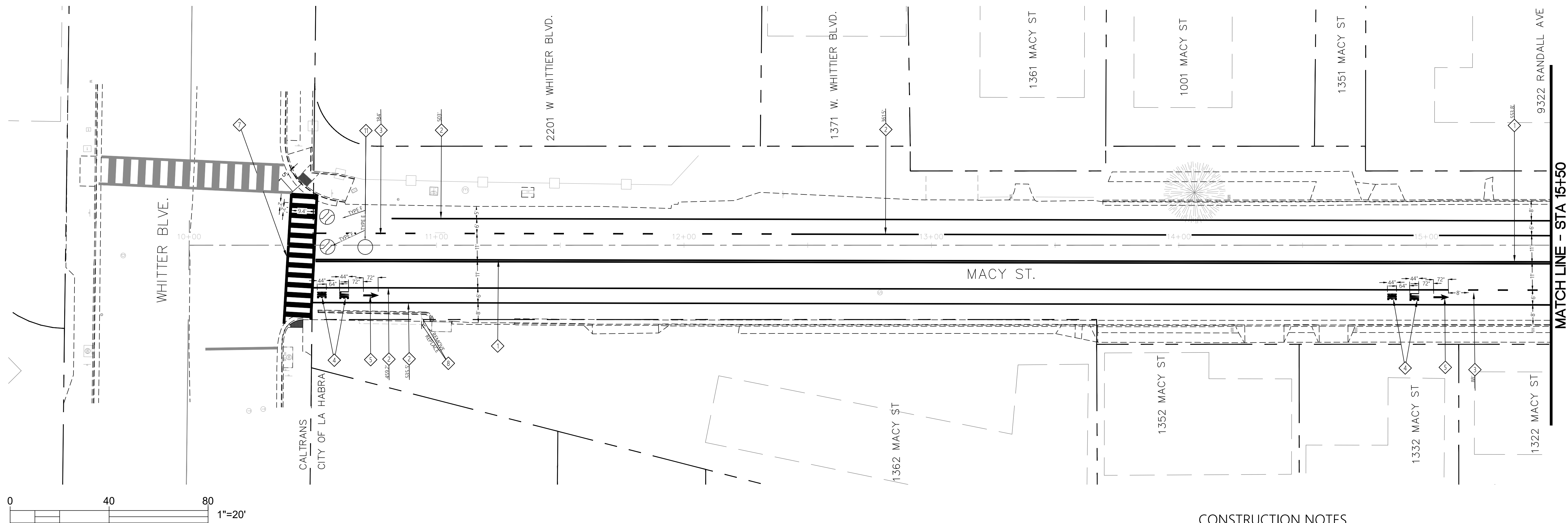

MATCH LINE - STA 15+50
SEE SHEET 9

CONSTRUCTION NOTES

- 1. TWO DIRECTION NO PASSING ZONE PER CALTRANS STANDARD PLAN A20A DETAIL 22.
- 2. BIKE LANE LINE PER CALTRANS STANDARD PLAN A20D DETAIL 39.
- 3. BIKE LANE, INTERSECTION LINE PER CALTRANS STANDARD PLAN A20D DETAIL 39A.
- 4. PAVEMENT MARKING WORDS AS SHOWN ON PLAN, PER CALTRANS STANDARD PLAN A24D, SPACED PER CA MUTCD FIGURE 9C-3.
- 5. BIKE LANE ARROW PER CALTRANS STANDARD PLAN A24A, SPACED PER CA MUTCD FIGURE 9C-3.
- 6. INSTALL 10' WIDE LADDER CROSSWALK PER CALTRANS STD. PLAN A24F 2' LADDER WITH 2' SPACING.
- 7. REMOVE EXISTING SIGN AND POST. PATCH PCC IF NEEDED. ATTACH EXISTING SIGN TO NEW TELSPAR POST IN NEW LOCATION PER PLAN.
- 8. INSTALL DETECTION LOOP PER CALTRANS STANDARD PLAN ES-5B

GENERAL NOTES

1. ALL TRAFFIC LINES AND PAVEMENT MARKINGS SHALL BE INSTALLED WITH THERMOPLASTIC BY THE CONTRACTOR, UNLESS OTHERWISE NOTED.
2. ALL TRAFFIC LINES AND PAVEMENT MARKINGS SHALL CONFORM TO CALTRANS STANDARD PLANS AND SPECIFICATIONS (2023 EDITION)
3. ALL CONFLICTING LINES AND MARKINGS SHALL BE REMOVED BY WET SANDBLASTING.
4. ALL TURN ARROW MARKINGS SHALL BE TYPE IV (L OR R) UNLESS OTHERWISE NOTED.
5. ALL LANE STRIPING AT INTERSECTION APPROACHES WITHOUT CROSSWALKS OR LIMIT LINES SHALL END 10 FEET FROM THE EXTENSION OF THE INTERSECTING CURB LINE.
6. ALL LANE LINES AT INTERSECTION APPROACHES AND DEPARTURES SHALL BEGIN AND END WITH 50 FEET OF 4-INCH SOLID WHITE LINE, UNLESS OTHERWISE NOTED.
7. LANE WIDTHS SHALL BE MEASURED BETWEEN THE CENTERLINES OF EACH ADJACENT SINGLE OR DOUBLE STRIPE OR TOP OF CURB AS APPROPRIATE.
8. PROPOSED LIMIT LINE SHOULD BE INSTALLED AT A MINIMUM OF 4 FEET BEHIND THE CURB EXTENSION OR EDGE OF TRAVEL WAY. IN THE CASE OF AN INTERSECTION WITH A CURB ACCESS RAMP, THE LIMIT LINE SHALL BE PLACED BEHIND THE RAMP'S LANDING AREA, BUT IN NO CASE GREATER THAN 30 FEET BACK.
9. ALL NEW SIGNING AND STRIPING SHALL CONFORM TO THE CALIFORNIA MANUAL OF UNIFORM TRAFFIC CONTROL DEVICES, 2014 EDITION.
10. ALL HOUSE ADDRESSES SHALL BE RE-PAINTED BY CONTRACTOR.

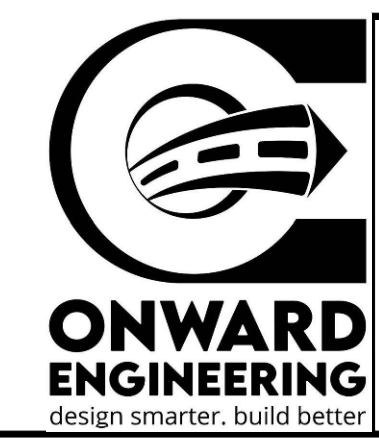

REV.	DATE	DESCRIPTION	BY
1			
2			
3			
4			

CITY OF LA HABRA

MACY STREET STRIPING PLANS

WHITTIER BLVD. TO JANINE DR.

SUBMITTED BY: <i>Justin Smeets</i> JUSTIN SMEETS, P.E., PROJECT MANAGER DATE: DECEMBER 20, 2024	PROJECT NO. 1-R-23 SHEET 08 of 11
---	---

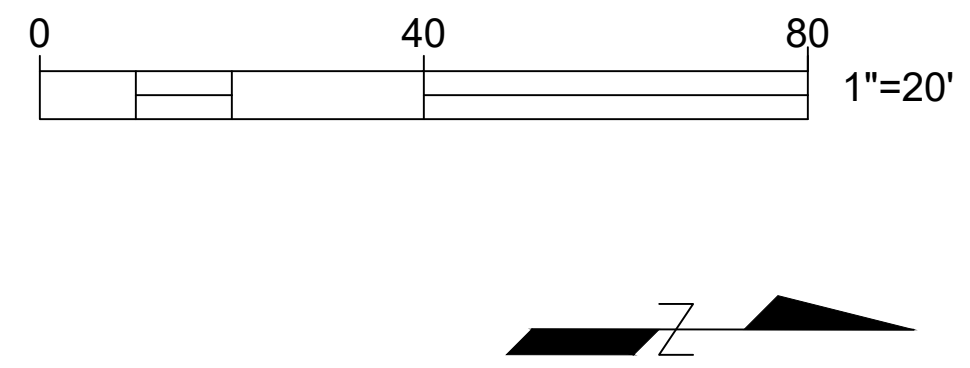
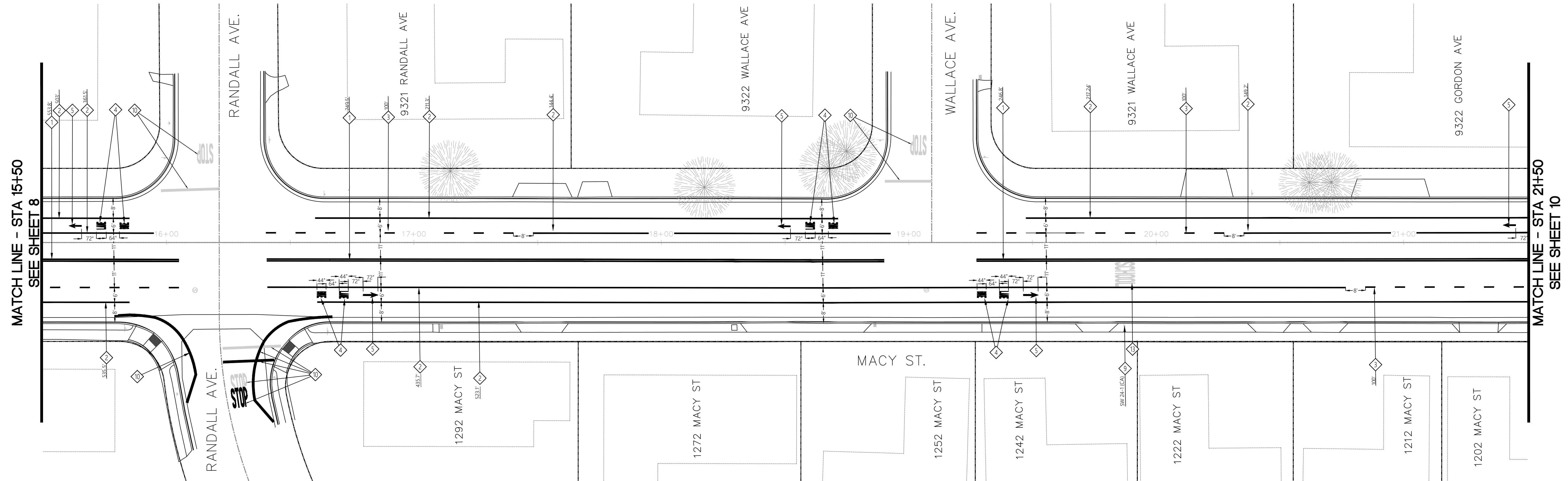

MATCH LINE - STA 15+50
SEE SHEET 8

MATCH LINE - STA 21+50
SEE SHEET 10

- CONSTRUCTION NOTES**
- 1. TWO DIRECTION NO PASSING ZONE PER CALTRANS STANDARD PLAN A20A DETAIL 22.
 - 2. BIKE LANE LINE PER CALTRANS STANDARD PLAN A20D DETAIL 39.
 - 3. BIKE LANE, INTERSECTION LINE PER CALTRANS STANDARD PLAN A20D DETAIL 39A.
 - 4. PAVEMENT MARKING WORDS AS SHOWN ON PLAN, PER CALTRANS STANDARD PLAN A24D, SPACED PER CA MUTCD FIGURE 9C-3.
 - 5. BIKE LANE ARROW PER CALTRANS STANDARD PLAN A24A, SPACED PER CA MUTCD FIGURE 9C-3.
 - 6. INSTALL NEW SIGN ON NEW TELSAR POST PER PLAN.
 - 7. WET SAND BLAST AND REPLACE WITH THERMOPLASTIC.
 - 8. WET SAND BLAST FOR REMOVAL.

GENERAL NOTES

1. ALL TRAFFIC LINES AND PAVEMENT MARKINGS SHALL BE INSTALLED WITH THERMOPLASTIC BY THE CONTRACTOR, UNLESS OTHERWISE NOTED.
2. ALL TRAFFIC LINES AND PAVEMENT MARKINGS SHALL CONFORM TO CALTRANS STANDARD PLANS AND SPECIFICATIONS (2023 EDITION)
3. ALL CONFLICTING LINES AND MARKINGS SHALL BE REMOVED BY WET SANDBLASTING.
4. ALL TURN ARROW MARKINGS SHALL BE TYPE IV (L OR R) UNLESS OTHERWISE NOTED.
5. ALL LANE STRIPING AT INTERSECTION APPROACHES WITHOUT CROSSWALKS OR LIMIT LINES SHALL END 10 FEET FROM THE EXTENSION OF THE INTERSECTING CURB LINE.
6. ALL LANE LINES AT INTERSECTION APPROACHES AND DEPARTURES SHALL BEGIN AND END WITH 50 FEET OF 4-INCH SOLID WHITE LINE, UNLESS OTHERWISE NOTED.
7. LANE WIDTHS SHALL BE MEASURED BETWEEN THE CENTERLINES OF EACH ADJACENT SINGLE OR DOUBLE STRIPE OR TOP OF CURB AS APPROPRIATE.
8. PROPOSED LIMIT LINE SHOULD BE INSTALLED AT A MINIMUM OF 4 FEET BEHIND THE CURB EXTENSION OR EDGE OF TRAVEL WAY. IN THE CASE OF AN INTERSECTION WITH A CURB ACCESS RAMP, THE LIMIT LINE SHALL BE PLACED BEHIND THE RAMP'S LANDING AREA, BUT IN NO CASE GREATER THAN 30 FEET BACK.
9. ALL NEW SIGNING AND STRIPING SHALL CONFORM TO THE CALIFORNIA MANUAL OF UNIFORM TRAFFIC CONTROL DEVICES, 2014 EDITION.
10. ALL HOUSE ADDRESSES SHALL BE RE-PAINTED BY CONTRACTOR.

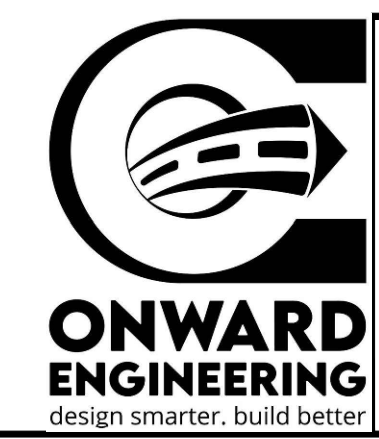

CITY OF LA HABRA																
MACY STREET STRIPING PLANS																
WHITTIER BLVD. TO JANINE DR.																
<table border="1"> <tr><th>REV.</th><th>DATE</th><th>DESCRIPTION</th></tr> <tr><td>1</td><td></td><td></td></tr> <tr><td>2</td><td></td><td></td></tr> <tr><td>3</td><td></td><td></td></tr> <tr><td>4</td><td></td><td></td></tr> </table>	REV.	DATE	DESCRIPTION	1			2			3			4			<p>SUBMITTED BY: <i>Justin Smeets</i></p> <p>JUSTIN SMEETS, P.E., PROJECT MANAGER</p> <p>DATE: DECEMBER 20, 2024</p>
REV.	DATE	DESCRIPTION														
1																
2																
3																
4																
PROJECT NO. 1-R-23	SHEET 09 of 11															

MATCH LINE - STA 21+50
SEE SHEET 9

MATCH LINE - STA 27+50
SEE SHEET 11

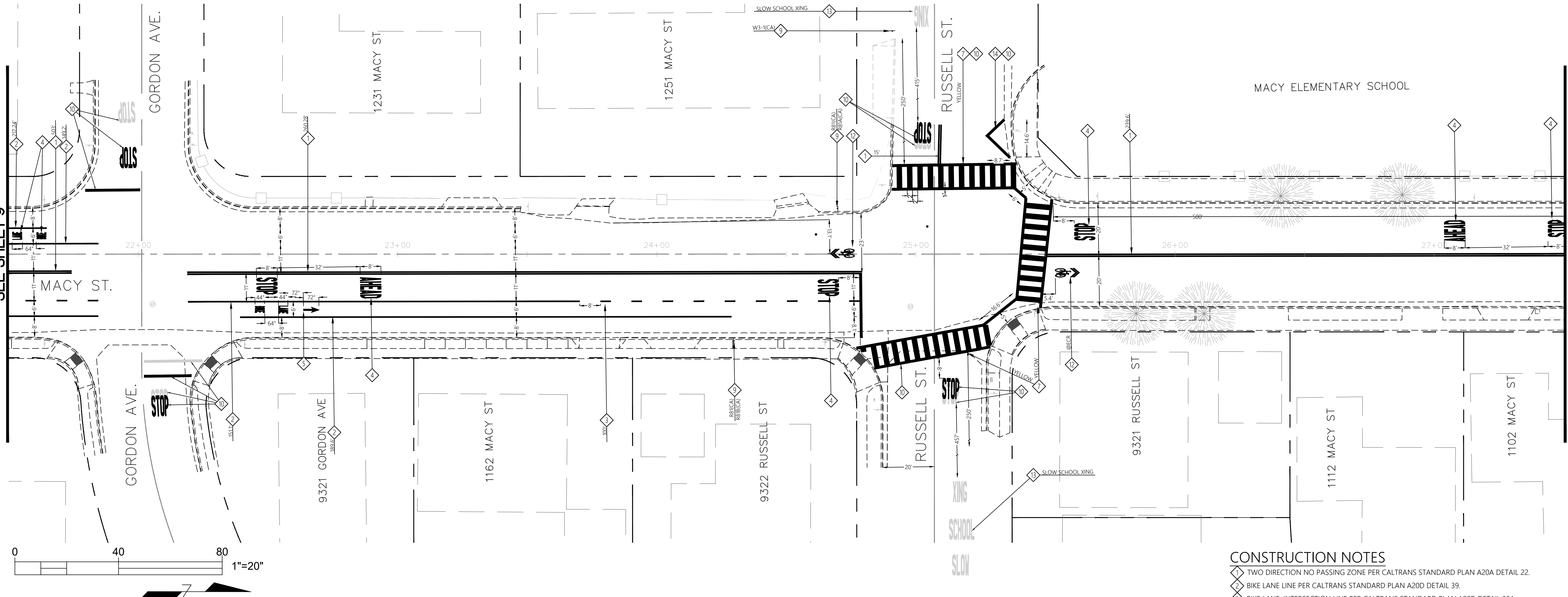

- CONSTRUCTION NOTES**
- 1. TWO DIRECTION NO PASSING ZONE PER CALTRANS STANDARD PLAN A20A DETAIL 22.
 - 2. BIKE LANE LINE PER CALTRANS STANDARD PLAN A20D DETAIL 39.
 - 3. BIKE LANE, INTERSECTION LINE PER CALTRANS STANDARD PLAN A20D DETAIL 39A.
 - 4. PAVEMENT MARKING WORDS AS SHOWN ON PLAN, PER CALTRANS STANDARD PLAN A24D, SPACED PER CA MUTCD FIGURE 9C-3.
 - 5. BIKE LANE ARROW PER CALTRANS STANDARD PLAN A24A, SPACED PER CA MUTCD FIGURE 9C-3.
 - 6. INSTALL 10' WIDE LADDER CROSSWALK PER CALTRANS STD. PLAN A24F 2' LADDER WITH 2' SPACING.
 - 7. INSTALL NEW SIGN ON NEW TELSPAR POST PER PLAN.
 - 8. WET SAND BLAST AND REPLACE WITH THERMOPLASTIC.
 - 9. INSTALL SHARED ROADWAY BICYCLE MARKING PER CALTRANS STD. PLAN A24C, LOCATED PER CA MUTCD FIGURES 9C-9 AND 9C-108.
 - 10. WET SAND BLAST FOR REMOVAL.
 - 11. INSTALL 6" WHITE CHANNELIZING LINE PER CALTRANS STANDARD PLAN A20D DETAIL 38A.

GENERAL NOTES

1. ALL TRAFFIC LINES AND PAVEMENT MARKINGS SHALL BE INSTALLED WITH THERMOPLASTIC BY THE CONTRACTOR, UNLESS OTHERWISE NOTED.
2. ALL TRAFFIC LINES AND PAVEMENT MARKINGS SHALL CONFORM TO CALTRANS STANDARD PLANS AND SPECIFICATIONS (2023 EDITION)
3. ALL CONFLICTING LINES AND MARKINGS SHALL BE REMOVED BY WET SANDBLASTING.
4. ALL TURN ARROW MARKINGS SHALL BE TYPE IV (L OR R) UNLESS OTHERWISE NOTED.
5. ALL LANE STRIPING AT INTERSECTION APPROACHES WITHOUT CROSSWALKS OR LIMIT LINES SHALL END 10 FEET FROM THE EXTENSION OF THE INTERSECTING CURB LINE.
6. ALL LANE LINES AT INTERSECTION APPROACHES AND DEPARTURES SHALL BEGIN AND END WITH 50 FEET OF 4-INCH SOLID WHITE LINE, UNLESS OTHERWISE NOTED.
7. LANE WIDTHS SHALL BE MEASURED BETWEEN THE CENTERLINES OF EACH ADJACENT SINGLE OR DOUBLE STRIPE OR TOP OF CURB AS APPROPRIATE.
8. PROPOSED LIMIT LINE SHOULD BE INSTALLED AT A MINIMUM OF 4 FEET BEHIND THE CURB EXTENSION OR EDGE OF TRAVEL WAY. IN THE CASE OF AN INTERSECTION WITH A CURB ACCESS RAMP, THE LIMIT LINE SHALL BE PLACED BEHIND THE RAMP'S LANDING AREA, BUT IN NO CASE GREATER THAN 30 FEET BACK.
9. ALL NEW SIGNING AND STRIPING SHALL CONFORM TO THE CALIFORNIA MANUAL OF UNIFORM TRAFFIC CONTROL DEVICES, 2014 EDITION.
10. ALL HOUSE ADDRESSES SHALL BE RE-PAINTED BY CONTRACTOR.

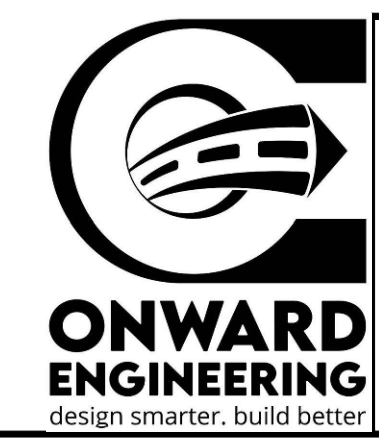

REV	DATE	DESCRIPTION	BY
1			
2			
3			
4			

CITY OF LA HABRA

MACY STREET STRIPING PLANS

WHITTIER BLVD. TO JANINE DR.

SUBMITTED BY: *Justin Smeets*

JUSTIN SMEETS, P.E., PROJECT MANAGER

DATE: DECEMBER 20, 2024

PROJECT NO. 1-R-23

SHEET 10 OF 11

MATCH LINE - STA 27+50
SEE SHEET 10

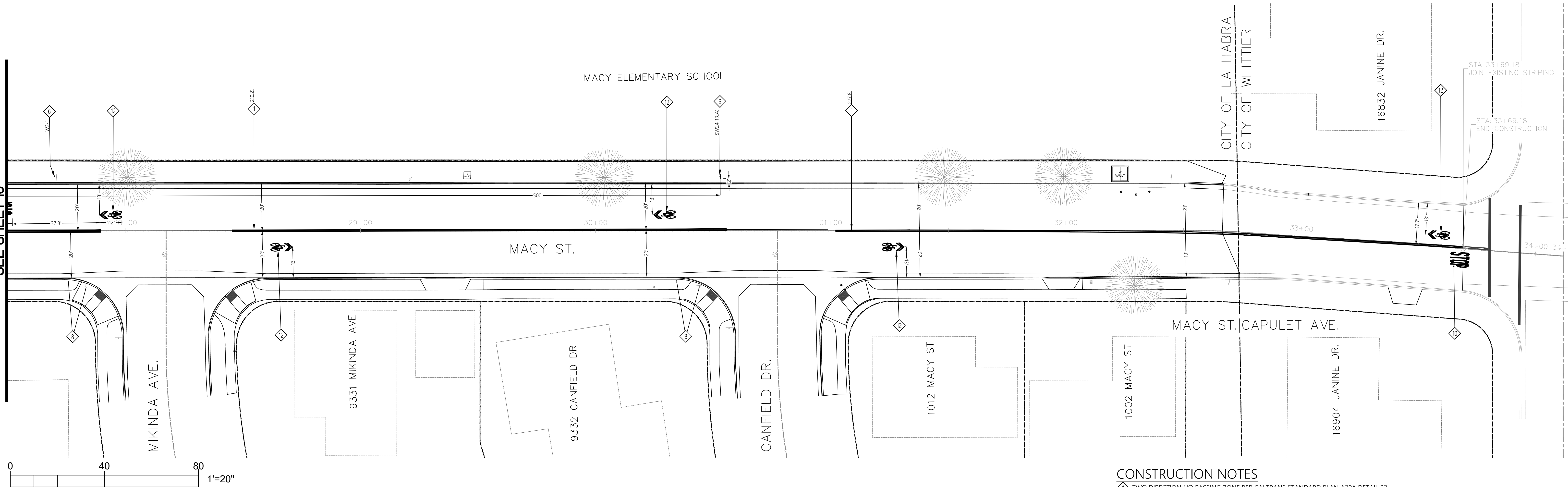

CONSTRUCTION NOTES

- ◆ TWO DIRECTION NO PASSING ZONE PER CALTRANS STANDARD PLAN A20A DETAIL 22.
- ◆ REMOVE EXISTING SIGN AND REPLACE WITH NEW SIGN PER PLAN.
- ◆ REMOVE EXISTING SIGN AND POST. PATCH PCC IF NEEDED. ATTACH EXISTING SIGN TO NEW TELSAR POST IN NEW LOCATION PER PLAN.
- ◆ INSTALL NEW SIGN ON NEW TELSAR POST PER PLAN.
- ◆ WET SAND BLAST AND REPLACE WITH THERMOPLASTIC.
- ◆ INSTALL SHARED ROADWAY BICYCLE MARKING PER CALTRANS STD. PLAN A24C, LOCATED PER CA MUTCD FIGURES 9C-9 AND 9C-10B.

GENERAL NOTES

1. ALL TRAFFIC LINES AND PAVEMENT MARKINGS SHALL BE INSTALLED WITH THERMOPLASTIC BY THE CONTRACTOR, UNLESS OTHERWISE NOTED.
2. ALL TRAFFIC LINES AND PAVEMENT MARKINGS SHALL CONFORM TO CALTRANS STANDARD PLANS AND SPECIFICATIONS (2023 EDITION)
3. ALL CONFLICTING LINES AND MARKINGS SHALL BE REMOVED BY WET SANDBLASTING.
4. ALL TURN ARROW MARKINGS SHALL BE TYPE IV (L OR R) UNLESS OTHERWISE NOTED.
5. ALL LANE STRIPING AT INTERSECTION APPROACHES WITHOUT CROSSWALKS OR LIMIT LINES SHALL END 10 FEET FROM THE EXTENSION OF THE INTERSECTING CURB LINE.
6. ALL LANE LINES AT INTERSECTION APPROACHES AND DEPARTURES SHALL BEGIN AND END WITH 50 FEET OF 4-INCH SOLID WHITE LINE, UNLESS OTHERWISE NOTED.
7. LANE WIDTHS SHALL BE MEASURED BETWEEN THE CENTERLINES OF EACH ADJACENT SINGLE OR DOUBLE STRIPE OR TOP OF CURB AS APPROPRIATE.
8. PROPOSED LIMIT LINE SHOULD BE INSTALLED AT A MINIMUM OF 4 FEET BEHIND THE CURB EXTENSION OR EDGE OF TRAVEL WAY. IN THE CASE OF AN INTERSECTION WITH A CURB ACCESS RAMP, THE LIMIT LINE SHALL BE PLACED BEHIND THE RAMP'S LANDING AREA, BUT IN NO CASE GREATER THAN 30 FEET BACK.
9. ALL NEW SIGNING AND STRIPING SHALL CONFORM TO THE CALIFORNIA MANUAL OF UNIFORM TRAFFIC CONTROL DEVICES, 2014 EDITION.
10. ALL HOUSE ADDRESSES SHALL BE RE-PAINTED BY CONTRACTOR.

CITY OF LA HABRA																					
MACY STREET STRIPING PLANS																					
WHITTIER BLVD. TO JANINE DR.																					
<table border="1"> <thead> <tr> <th>REV.</th> <th>DATE</th> <th>DESCRIPTION</th> <th>BY</th> </tr> </thead> <tbody> <tr> <td>1</td> <td></td> <td></td> <td></td> </tr> <tr> <td>2</td> <td></td> <td></td> <td></td> </tr> <tr> <td>3</td> <td></td> <td></td> <td></td> </tr> <tr> <td>4</td> <td></td> <td></td> <td></td> </tr> </tbody> </table>	REV.	DATE	DESCRIPTION	BY	1				2				3				4				<p>SUBMITTED BY: <i>Justin Smeets</i></p> <p>JUSTIN SMEETS, P.E., PROJECT MANAGER</p> <p>DATE: DECEMBER 20, 2024</p>
REV.	DATE	DESCRIPTION	BY																		
1																					
2																					
3																					
4																					
PROJECT NO. 1-R-23	SHEET 11 OF 11																				

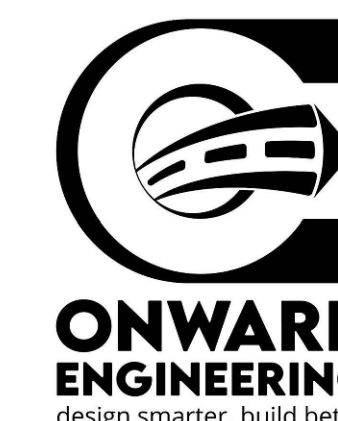

APPENDIX “B”

STANDARD PLANS

- SPPWC 110-2
- SPPWC 113-2
- SPPWC 120-3
- Standard Detail R-19
- CALTRANS STD. PLAN A20A
- CALTRANS STD. PLAN A20D
- CALTRANS STD. PLAN A24A
- CALTRANS STD. PLAN A24C
- CALTRANS STD. PLAN A24D
- CALTRANS STD. PLAN A24F
- CALTRANS STD. PLAN ES-5B

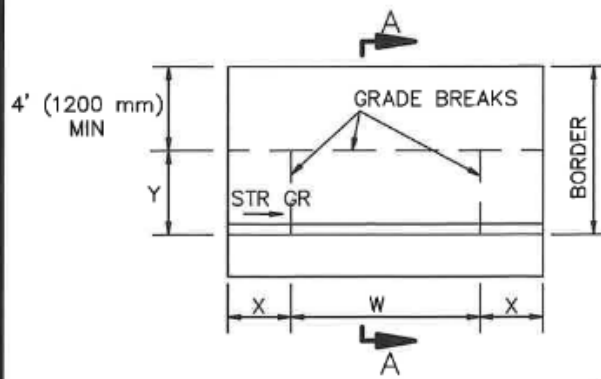

TYPE A

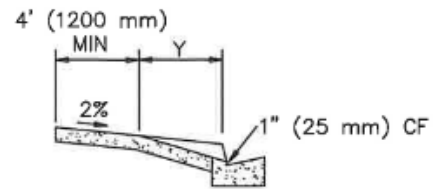

SECTION A-A

CURB FACE, inches (mm)	X, inches (mm)	Y, inches (mm)
6" (150) or less	3'-0" (900)	4'-0" (1200)
7" (175)	3'-6" (1050)	4'-9" (1425)
8" (200)	4'-0" (1200)	5'-8" (1700)
9" (225)	4'-6" (1350)	6'-6" (1950)
10" (250)	5'-0" (1500)	7'-3" (2175)
11" (275)	5'-6" (1650)	8'-0" (2400)
12" (300) or more	6'-0" (1800)	8'-9" (2625)

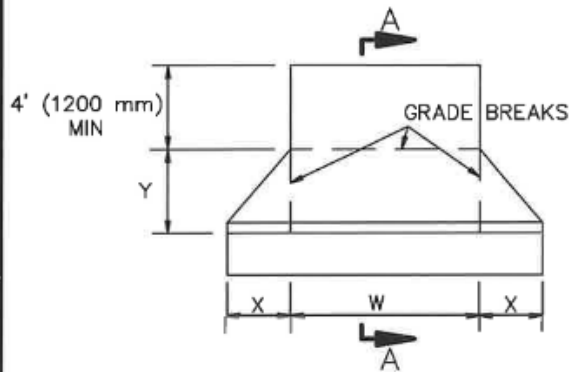

TYPE B

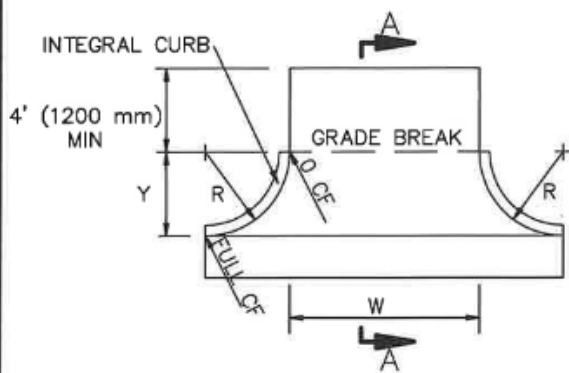

TYPE C

NOTES:

1. RESIDENTIAL DRIVEWAYS SHALL BE 4" (100 mm) THICK PCC.
2. COMMERCIAL DRIVEWAYS SHALL BE 6" (150 mm) THICK PCC.
3. WEAKENED PLANE JOINTS SHALL BE INSTALLED AT BOTH SIDES OF A DRIVEWAY AND AT 10' (3.0 m) INTERVALS.
4. CURB FOR TYPE C DRIVEWAY SHALL BE INTEGRAL AND MATCH ADJACENT CONSTRUCTION.
5. REFER TO LOCAL DEVELOPMENT REGULATIONS FOR AMERICANS WITH DISABILITIES ACCESS REQUIREMENTS AND MAXIMUM PERMITTED DRIVEWAY WIDTHS.

STANDARD PLANS FOR PUBLIC WORKS CONSTRUCTION

PROMULGATED BY THE
PUBLIC WORKS STANDARDS INC.
GREENBOOK COMMITTEE
1984
REV. 1996, 2009

DRIVEWAY APPROACHES

STANDARD PLAN

110-2

USE WITH STANDARD SPECIFICATIONS FOR PUBLIC WORKS CONSTRUCTION

SHEET 1 OF 1

WALK OR FILL-IN REPLACEMENT FOR EXCAVATIONS MADE
PARALLEL TO CURB OR PROPERTY LINE

WALK ADJACENT TO PROPERTY LINE

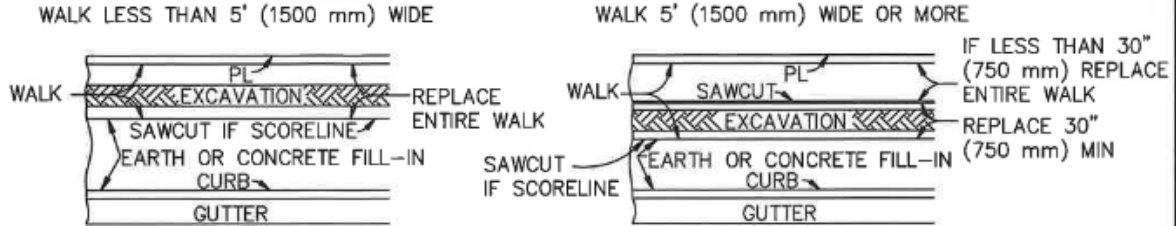

WALK ADJACENT TO CURB

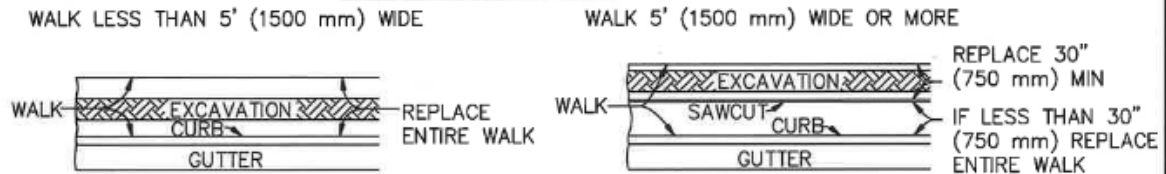

FILL-IN REPLACEMENT

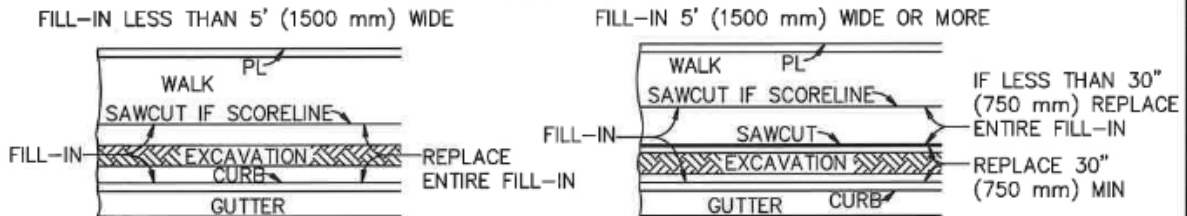

WALK OR FILL-IN REPLACEMENT FOR EXCAVATIONS MADE
NORMAL TO CURB OR PROPERTY LINE

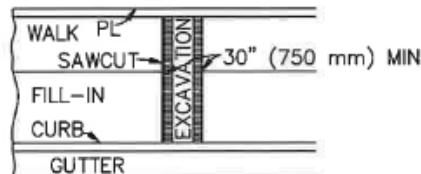

THESE REQUIREMENTS ALSO APPLY TO ENDS OF PARALLEL EXCAVATIONS.

IF AN EXCAVATION FALLS WITHIN 30" (750 mm) OF AN EXPANSION JOINT, CONSTRUCTION JOINT, WEAKENED PLANE JOINT, OR EDGE, THE CONCRETE SHALL BE REMOVED AND REPLACED TO THE JOINT OR EDGE.

IF AN EXCAVATION FALLS WITHIN 12" (300 mm) OF A SCORELINE, THE CONCRETE SHALL BE REMOVED AND REPLACED TO THE SCORELINE. THE SCORELINE SHALL BE SAWCUT BEFORE CONCRETE REMOVAL. THE MINIMUM LENGTH OF REPLACEMENT IN BOTH CASES SHALL BE 30" (750 mm).

STANDARD PLANS FOR PUBLIC WORKS CONSTRUCTION

PROMULGATED BY THE
PUBLIC WORKS STANDARDS INC.
GREENBOOK COMMITTEE
1993
REV. 1996, 2009

SIDEWALK & DRIVEWAY REPLACEMENT

USE WITH STANDARD SPECIFICATIONS FOR PUBLIC WORKS CONSTRUCTION

STANDARD PLAN

113-2

SHEET 1 OF 2

NOTES

1. CONCRETE WALK, FILL-IN AND DRIVEWAYS REMOVED IN CONNECTION WITH CONSTRUCTION SHALL BE REPLACED TO NEATLY SAWED EDGES. ALL CUTS SHALL BE PARALLEL TO OR PERPENDICULAR TO THE CURB; ON CURVES, THE CUT SHALL BE RADIAL TO THE CURB.
2. DRIVEWAY APRONS IN WHICH THE "W" DISTANCE IS LESS THAN 11' (3300 mm) SHALL BE REPLACED IN THEIR ENTIRETY IF CUT IN ANY AREA.
3. DRIVEWAY APRONS IN WHICH THE "W" DISTANCE IS 11' (3300 mm) OR MORE MAY BE CUT WITHIN THE "W" SECTION. THE MINIMUM REPLACEMENT SHALL BE 30" (750 mm) IN LENGTH. THE MINIMUM DISTANCE ALLOWED BETWEEN SUCH CUTS SHALL BE 14' (4200 mm).
4. DRIVEWAY APRONS IN WHICH THE "W" DISTANCE IS 11' (3300 mm) OR MORE MAY BE CUT IN THE "X" OR "R" SECTION. REPLACEMENT SHALL BE THE ENTIRE "X" OR "R" SECTION.
5. DRIVEWAY APRONS SHALL BE REPLACED FROM THE BACK OF THE CURB TO THE FRONT EDGE OF THE WALK, EXCEPT, WHERE WALK IS ADJACENT TO CURB, REPLACEMENT SHALL BE FROM BACK OF CURB TO BACK OF WALK.
6. WALK PORTIONS OF DRIVEWAYS SHALL BE REPLACED AS SHOWN ABOVE FOR EXCAVATIONS MADE PARALLEL OR NORMAL TO CURB.
7. REPLACEMENT OF THE "X" OR "R" SECTION SHALL MATCH EXISTING CONSTRUCTION.

STANDARD PLANS FOR PUBLIC WORKS CONSTRUCTION

SIDEWALK & DRIVEWAY REPLACEMENT

STANDARD PLAN

113-2

SHEET 2 OF 2

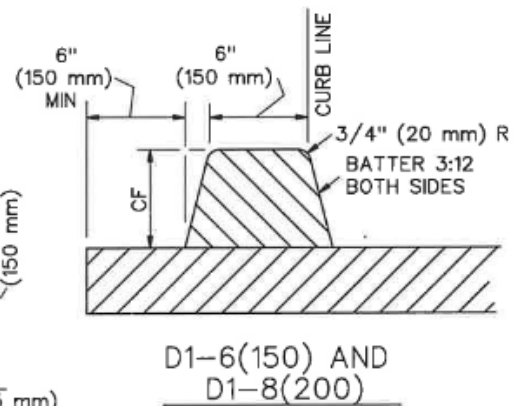
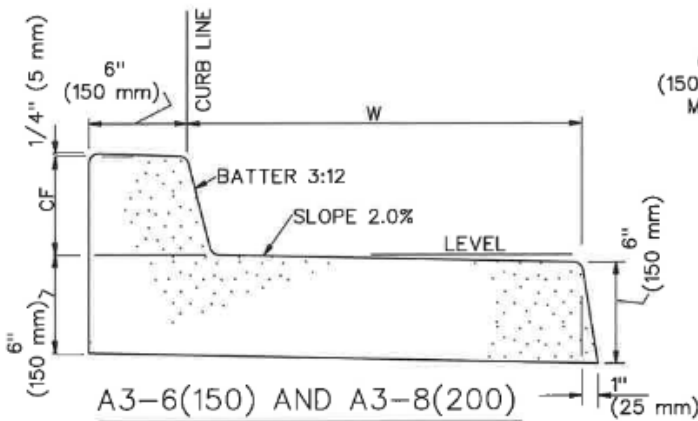
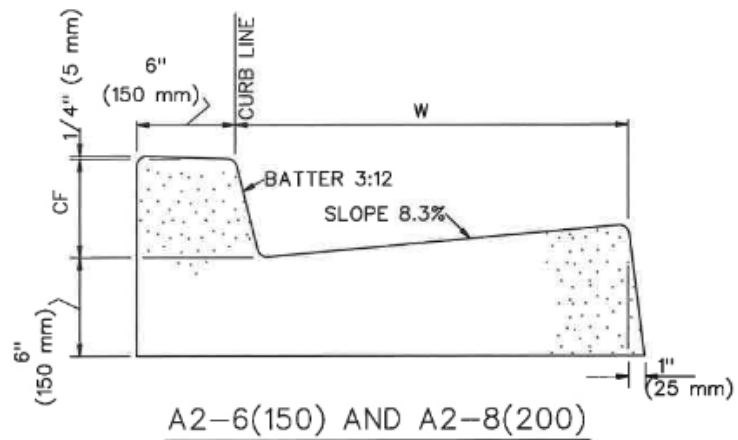
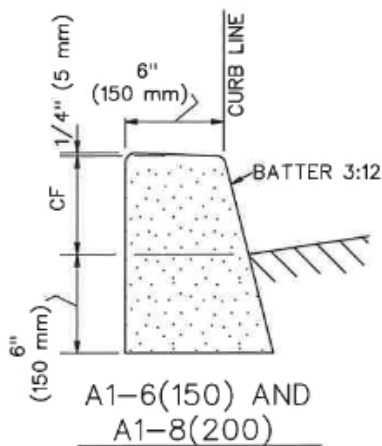

NOTES:

1. THE LAST NUMBER IN THE DESIGNATION IS THE CURB FACE (CF) HEIGHT, INCHES (mm). IF SHOWN AS 'VAR' THE CURB FACE VARIES.
2. GUTTER WIDTH, W, IS 24" (600 mm) UNLESS OTHERWISE SPECIFIED.
3. TYPES A1, A2, A3 AND C1 SHALL BE CONSTRUCTED OF CONCRETE.
4. TYPE D1 CURB SHALL BE CONSTRUCTED OF ASPHALT CONCRETE.
5. TYPE C1 CURB SHALL BE ANCHORED WITH STEEL DOWELS AS SHOWN OR WITH AN EPOXY APPROVED BY THE ENGINEER.
6. ALL EXPOSED CORNERS ON CONCRETE CURBS AND GUTTERS SHALL BE ROUNDED WITH A 1/2" (15 mm) RADIUS.

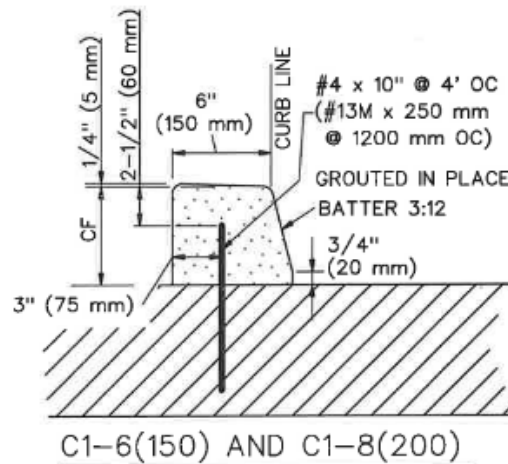

STANDARD PLANS FOR PUBLIC WORKS CONSTRUCTION

PROMULGATED BY THE
PUBLIC WORKS STANDARDS INC.
GREENBOOK COMMITTEE
1964
REV. 1986, 2009, 2021

CURB AND GUTTER - BARRIER

USE WITH STANDARD SPECIFICATIONS FOR PUBLIC WORKS CONSTRUCTION

STANDARD PLAN

120-3

SHEET 1 OF 1

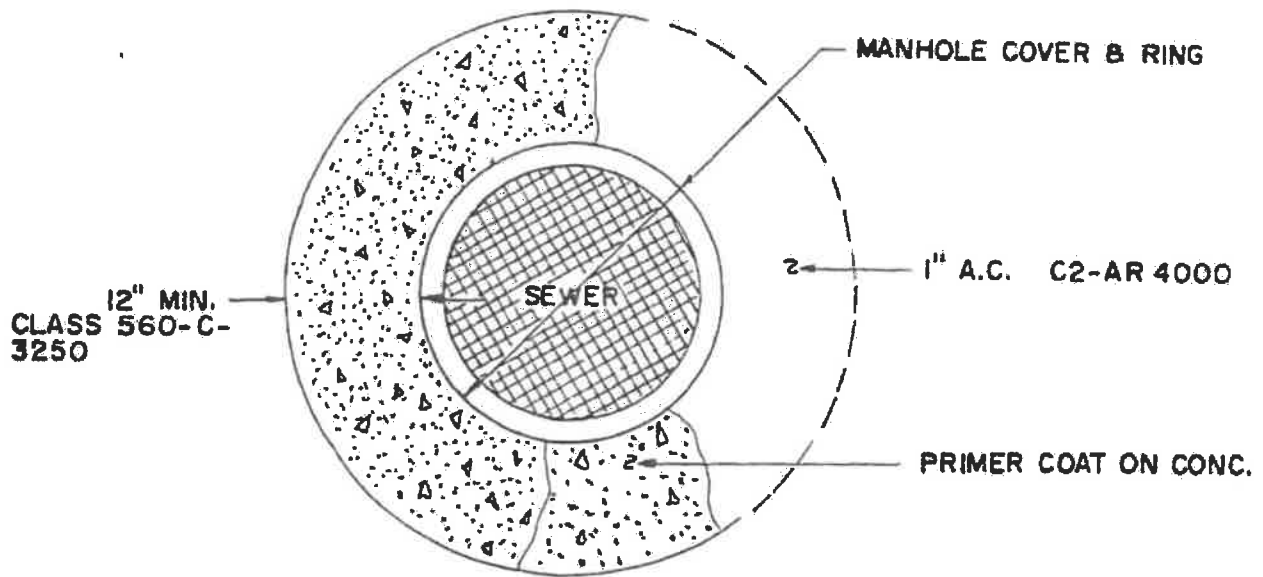

PLAN VIEW

CONC. MAY BE CIRCULAR OR SQUARE IN SHAPE WITH A MINIMUM DISTANCE OF 12" BETWEEN EDGE OF CONC. AND LIP OF M.H. RING.

MANHOLES MAY BE ADJUSTED TO GRADE USING BRICK AND MORTAR OR PRECAST RINGS AT THE CONTRACTORS OPTION.

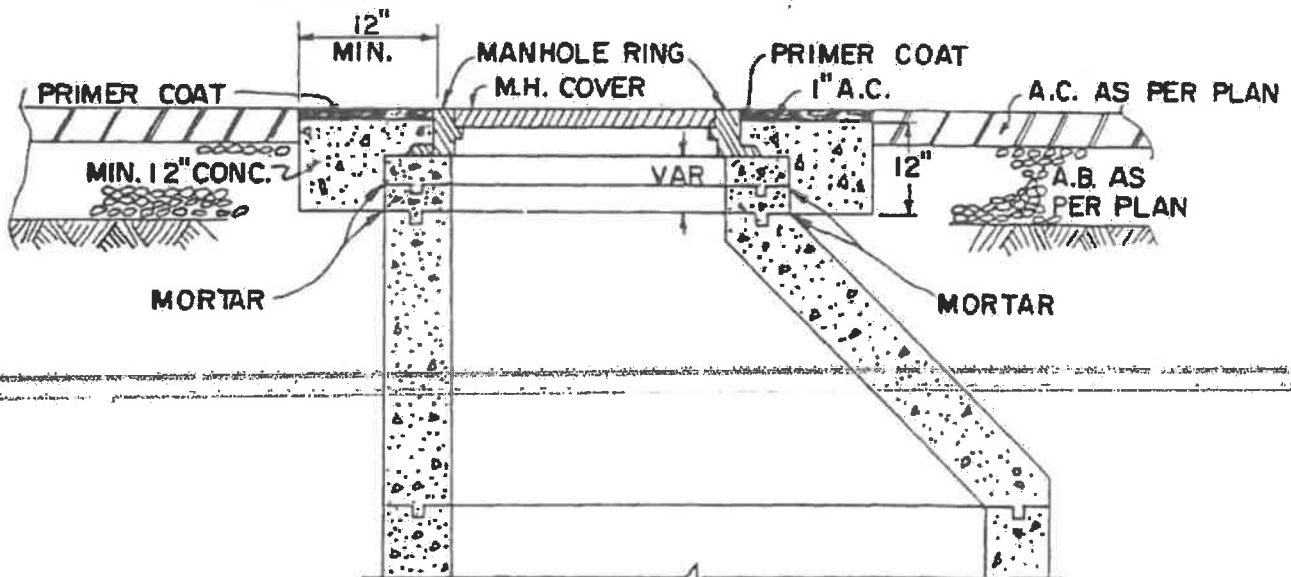

CROSS SECTION

CITY OF LA HABRA

MANHOLE ADJUSTMENT DETAILS

APPROVED *Rob B...* DATE 1-28-86

STANDARD DETAIL R-19A

DISTRICT COUNTY ROUTE
 SHEET NO. 1 OF 1
 TOTAL SHEETS
 REGISTERED CIVIL ENGINEER
 September 20, 2024
 THE STATE OF CALIFORNIA
 REGISTERED CIVIL ENGINEER
 No. 3-31-28
 (Seal)

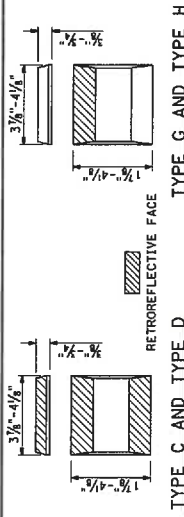

MARKER DETAILS

NO PASSING ZONES - ONE DIRECTION

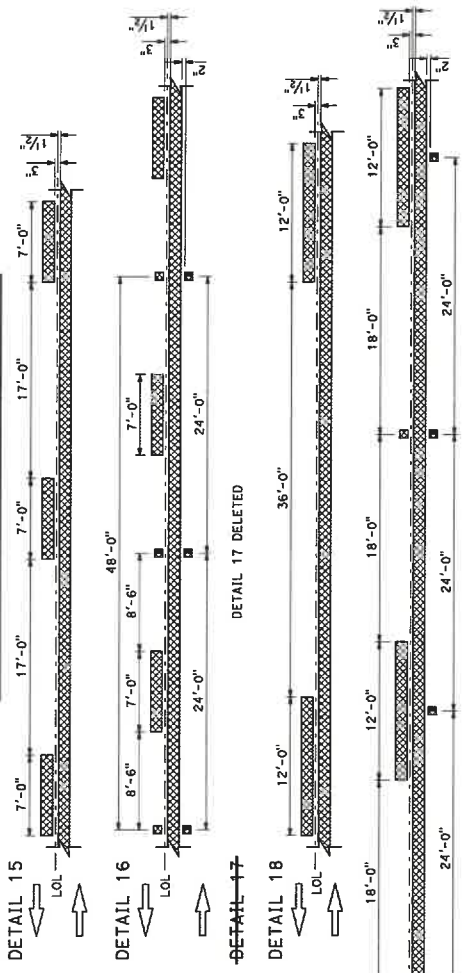

NO PASSING ZONES - TWO DIRECTION

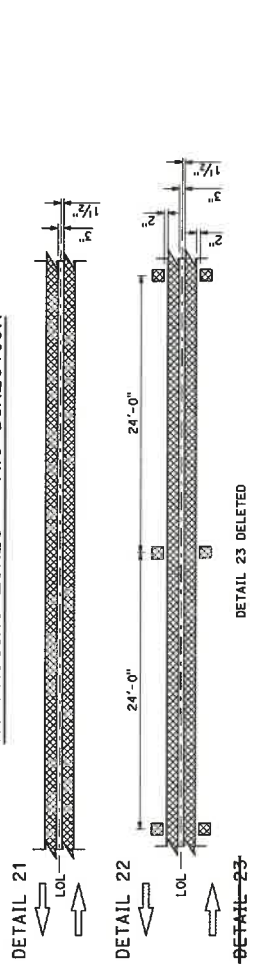

CENTERLINES
(2 LANE HIGHWAYS)

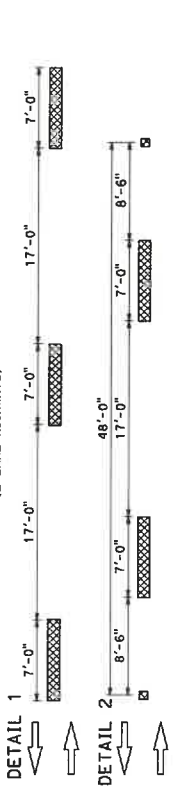

LANE LINES
(MULTILANE HIGHWAYS)

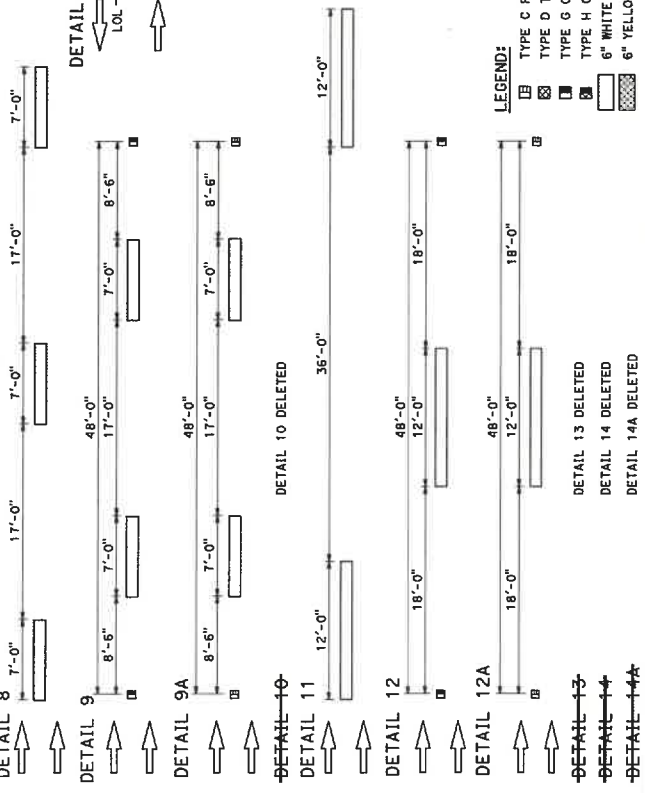

- LEGEND:
- TYPE C RED-CLEAR RETROREFLECTIVE MARKER
 - ▣ TYPE D TWO-WAY YELLOW RETROREFLECTIVE MARKER
 - ▤ TYPE G ONE-WAY CLEAR RETROREFLECTIVE MARKER
 - ▥ TYPE H ONE-WAY YELLOW RETROREFLECTIVE MARKER
 - ▧ 6" WHITE LINE
 - ▨ 6" YELLOW LINE

STATE OF CALIFORNIA
 DEPARTMENT OF TRANSPORTATION
PAVEMENT MARKERS AND TRAFFIC LINES
TYPICAL DETAILS
 NO SCALE

A20A

DIST COUNTY ROUTE POST MILES SHEET TOTAL
 TOTAL PROJECT NO. SHEETS
 REGISTERED CIVIL ENGINEER
 September 20, 2024
 PLANS APPROVAL DATE
 THE STATE OF CALIFORNIA OR ITS OFFICERS
 SHALL BE RESPONSIBLE FOR THE ACCURACY OF THE INFORMATION CONTAINED
 HEREON AND THE COMPLETENESS OF THE INFORMATION CONTAINED
 HEREON IS NOT GUARANTEED BY THE STATE OF CALIFORNIA.

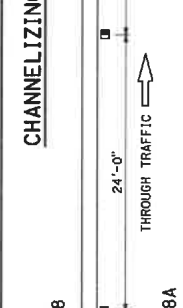
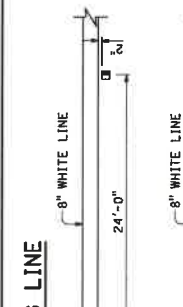

RECESS DETAIL FOR RETROREFLECTIVE PAVEMENT MARKER
 See Note 4
RECESSED PAVEMENT MARKER NOTES:
 1. See typical traffic line details for marker patterns to be used with recessed pavement markers.
 2. The retroreflective pavement markers shown are for use with non-recessed installations.
 3. The top of pavement markers installed in recesses shall be 0 to 1/8" below the pavement surface.
 4. Use Type 1 recess for pavement markers with one-way retroreflective face. Use Type 2 recess for pavement markers with two-way retroreflective face.
 5. For exit ramps, use Type 1 recess for Type B markers with one-way retroreflective face. Use Type 2 recess for Type H markers with two-way retroreflective face and place the marker at the upstream end of the recess.

STATE OF CALIFORNIA
 DEPARTMENT OF TRANSPORTATION
PAVEMENT MARKERS AND TRAFFIC LINES
TYPICAL DETAILS
 NO SCALE
A 20D

DI ST COUNTY ROUTE SHEET TITLE SHEET NO. TOTAL PROJECT SHEETS

A. Sorensen
REGISTERED CIVIL ENGINEER

September 20, 2024
Fresno, ALameda
PLANS ORIGINAL DATE
No. 081703
Exp. 3-31-26

REGISTERED PROFESSIONAL ENGINEER
STATE OF CALIFORNIA
No. 081703
Exp. 3-31-26

THE STATE OF CALIFORNIA OR ITS OFFICERS
OR AGENTS SHALL NOT BE RESPONSIBLE FOR
CONSEQUENCES OF THIS PLAN SHEET.

NOTE:
Minor variations in dimensions may be accepted by the Engineer.

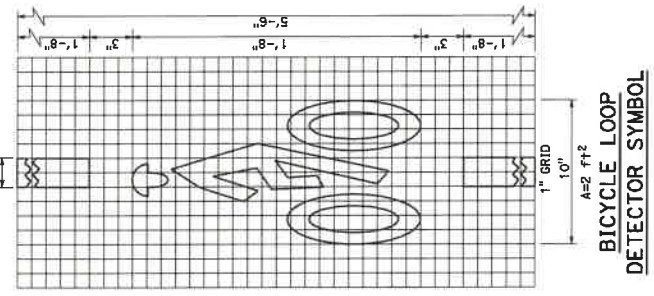
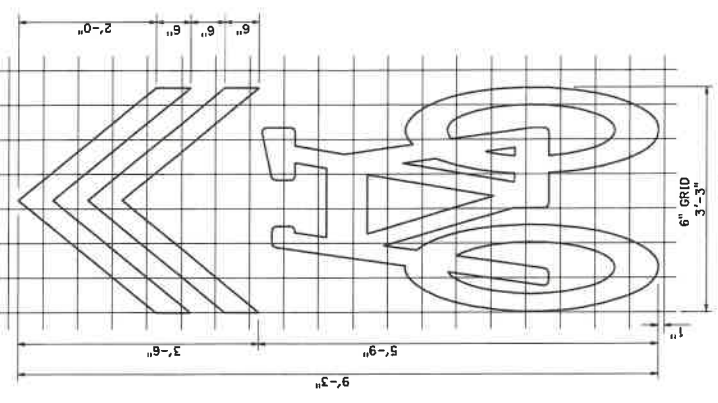
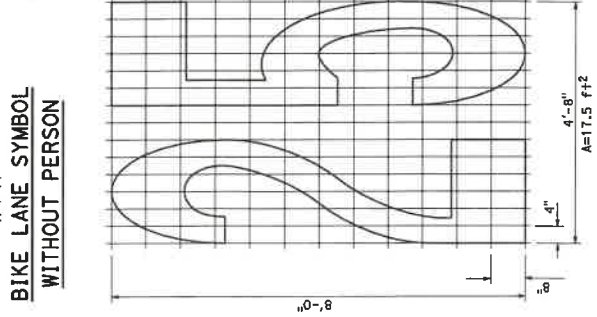
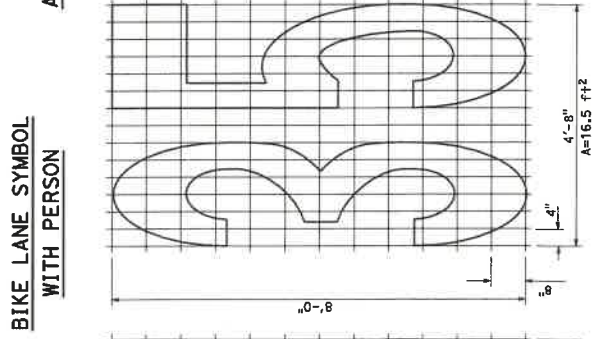
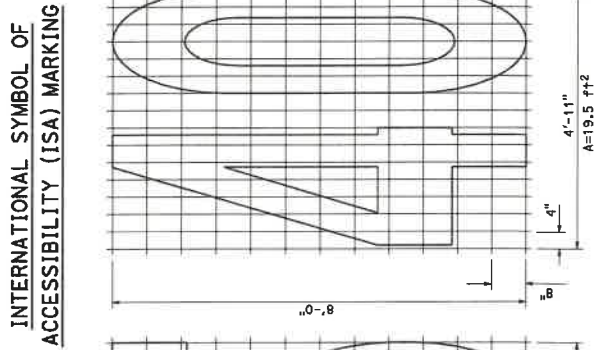
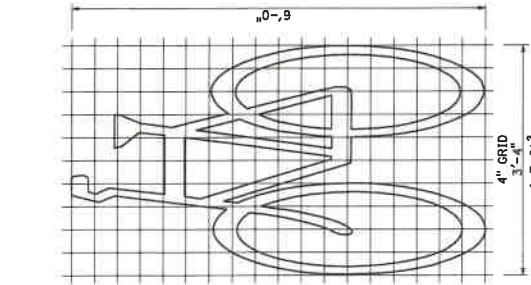
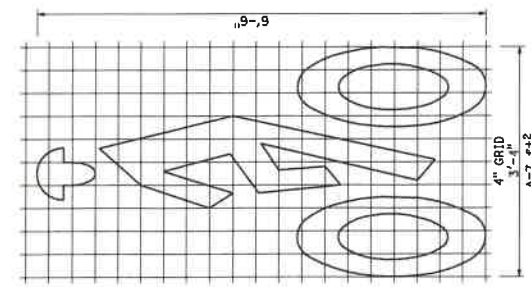
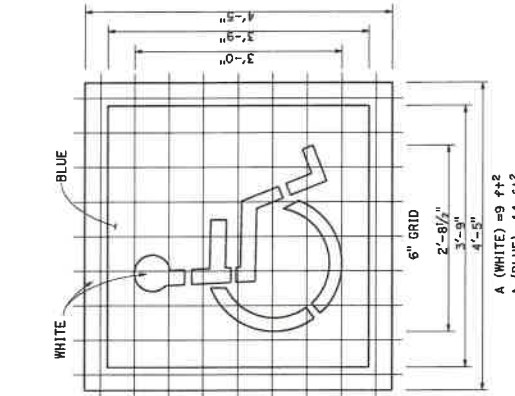
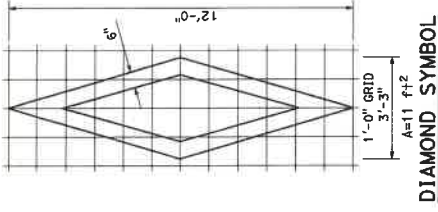

STATE OF CALIFORNIA
DEPARTMENT OF TRANSPORTATION

**PAVEMENT MARKINGS
SYMBOLS AND NUMERALS**

NO SCALE

A24C

DIST COUNTY ROUTE SHEET TOTAL PROJECT SHEET NO. TOTAL SHEETS

A. Saunders
REGISTERED CIVIL ENGINEER

September 30, 2024
PLANS APPROVAL DATE

REGISTERED PROFESSIONAL ENGINEER
Merrill Allen
No. 3-31-96
STATE OF CALIFORNIA

September 30, 2024
PLANS APPROVAL DATE

THE STATE OF CALIFORNIA OR ITS OFFICERS
OR AGENTS SHALL NOT BE RESPONSIBLE FOR
CONTRACTS OF THIS PLAN SHEET.

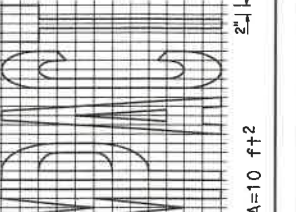
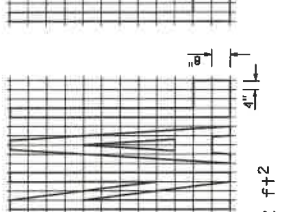
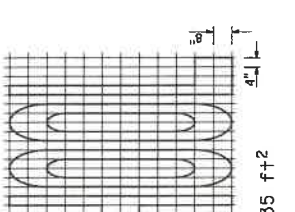
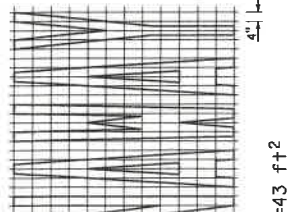
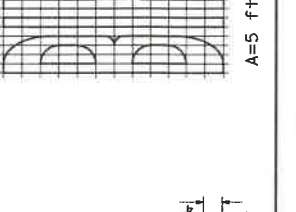
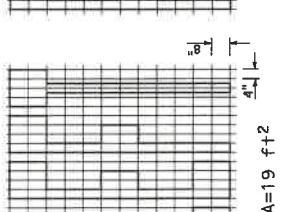
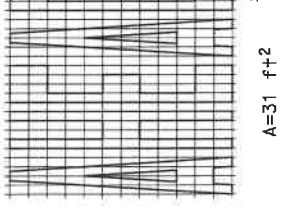
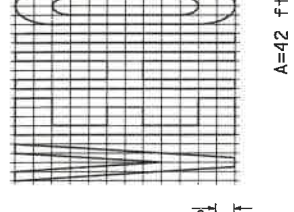
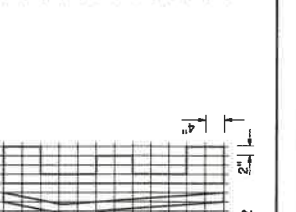
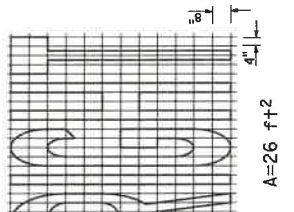
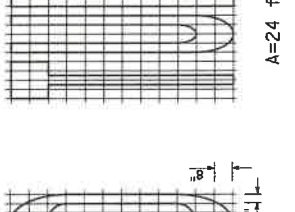
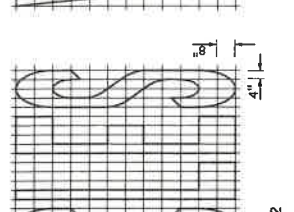
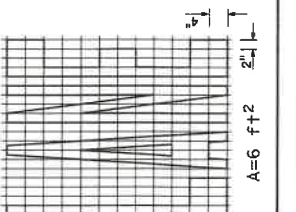
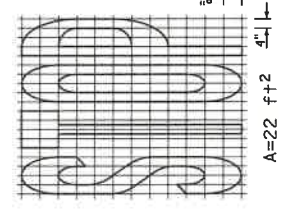
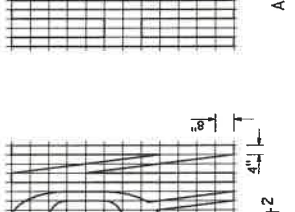
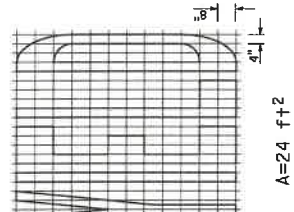
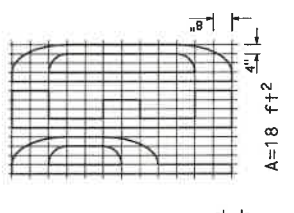
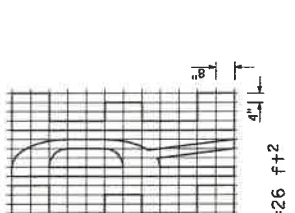
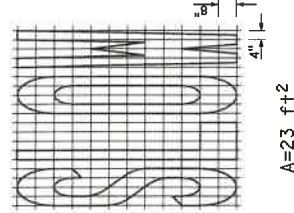
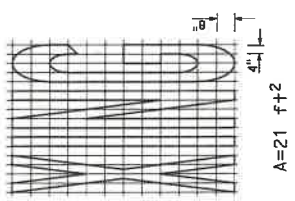
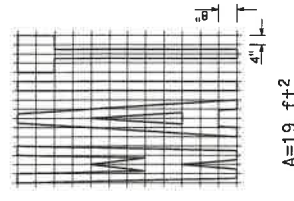

- NOTES:**
- If a message consists of more than one word, it must read "up", i.e., the first word must be nearest the driver.
 - The space between words must be at least four times the height of the characters for low speed roads, but not more than ten times the height of the characters. The space may be reduced appropriately where there is limited space because of local conditions.
 - Minor variations in dimensions may be accepted by the Engineer.
 - Portions of a letter, number or symbol may be separated by connecting segments not to exceed 2" in width.

WORD MARKINGS

ITEM	f+2	ITEM	f+2	ITEM	f+2		
XING	21	YIELD	24	BIKE	5	PED	18
AHEAD	31	SCHOOL	35	SLOW	23	COMPACT	10
WAIT	19	SIGNAL	32	STOP	22	RUNWAY	43
LANE	6	TURN	24	LEFT	19	VEHICLES	42
RIGHT	26	HERE	26				

STATE OF CALIFORNIA
DEPARTMENT OF TRANSPORTATION
PAVEMENT MARKINGS
WORD MARKINGS
NO SCALE

A24D

Return to Table of Contents

DIST.	COUNTY	ROUTE	POST MILES	SHEET NO.	TOTAL SHEETS

REGISTERED CIVIL ENGINEER
 September 20, 2024
 License Number: 081105
 THE STATE OF CALIFORNIA OR ITS OFFICERS
 OR AGENTS SHALL NOT BE RESPONSIBLE FOR
 ERRORS OR OMISSIONS ON THIS PLAN SHEET.

NOTES:

1. If a message consists of more than one word, it must read "up", i.e., the first word must be nearest the driver.
2. The space between words must be at least four times the height of the characters. The space may be reduced appropriately where there is limited space because of local conditions.
3. Minor variations in dimensions may be accepted by the Engineer.
4. Portions of a letter, number, or symbol may be separated by connecting segments not to exceed 2" in width.
5. The words "NO PARKING" pavement marking is to be used for parking facilities. For typical locations of markings, see Standard Plans A90A and A90B.
6. The words "NO PARKING" shall be painted in white letters no less than 1'-0" high on a contrasting background and located so that it is visible to traffic enforcement officials.

WORD MARKINGS

ITEM	SOFT	ITEM	SOFT
LANE	24	EXPRS	30
CLEAR	27	NO	14
KEEP	24	BIKE	21
HOV	18	BUS	20
TRAIL	23	ONLY	22
		WEST	24

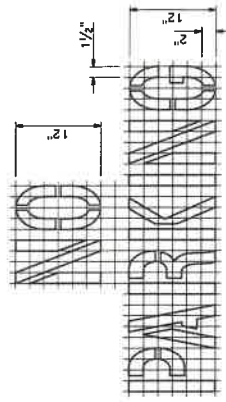
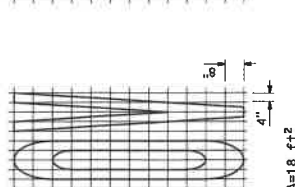
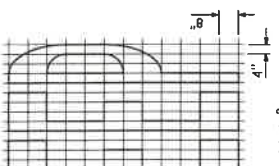
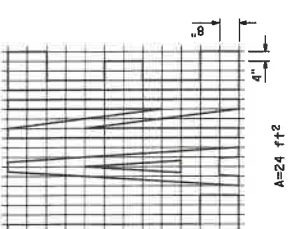
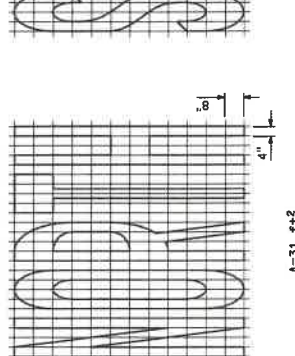
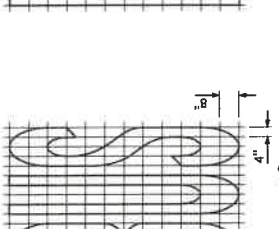
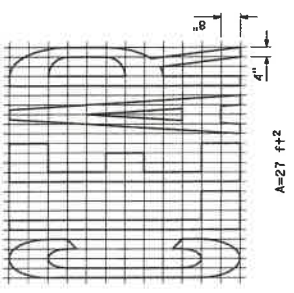
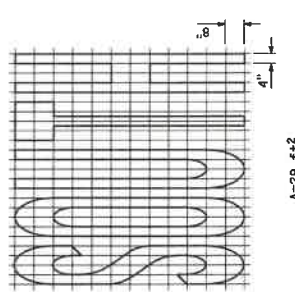
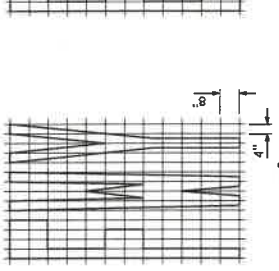
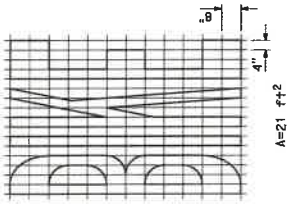
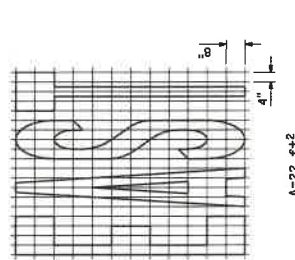
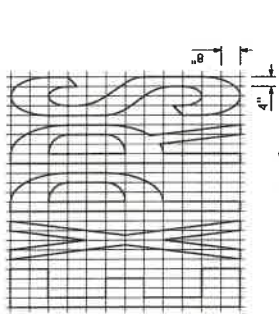
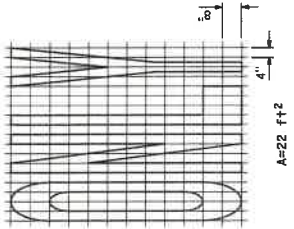
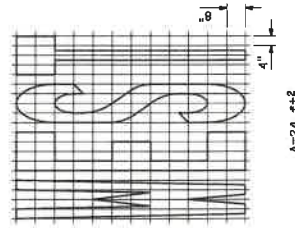
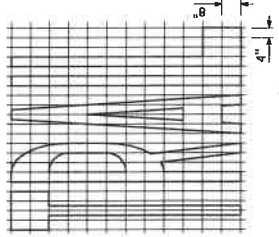
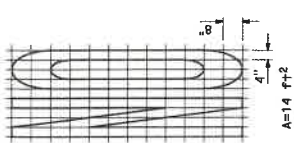

A=2 ft+2
 See Notes 5 and 6

STATE OF CALIFORNIA
 DEPARTMENT OF TRANSPORTATION
PAVEMENT MARKINGS
WORD MARKINGS
 NO SCALE

A24E

Return to Table of Contents

DIST.	COUNTY	ROUTE	POST MILES TOTAL PROJECT	SHEET TOTAL NO. SHEETS

REGISTERED CIVIL ENGINEER
Antonio Alvarez
 PROFESSIONAL ENGINEER
 No. 50105
 STATE OF CALIFORNIA
 EXPIRES 12/31/2025
 PLANS APPROVAL DATE: September 20, 2024
 THE STATE OF CALIFORNIA OR ITS OFFICERS AND EMPLOYEES ASSUME NO LIABILITY FOR THE ACCURACY OR COMPLETENESS OF ANY INFORMATION CONTAINED ON THIS PLAN SHEET.

NOTES:

1. Spaces between markings must be placed in wheel tracks of each lane.
2. Spacings not to exceed 2.5 x width of longitudinal line.
3. All crosswalk markings must be white except those near schools must be yellow.

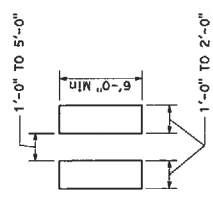

CONTINENTAL
See Note 1

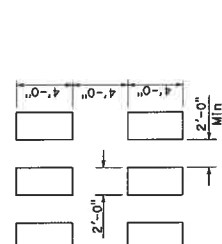

TRIPLE FOUR
See Note 1

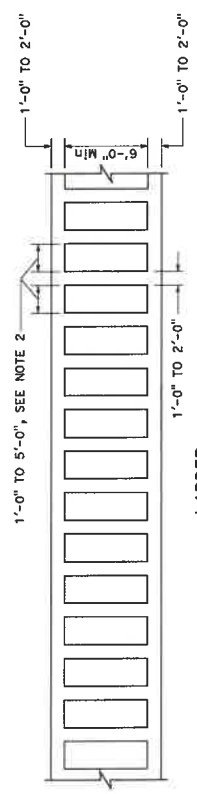

LADDER

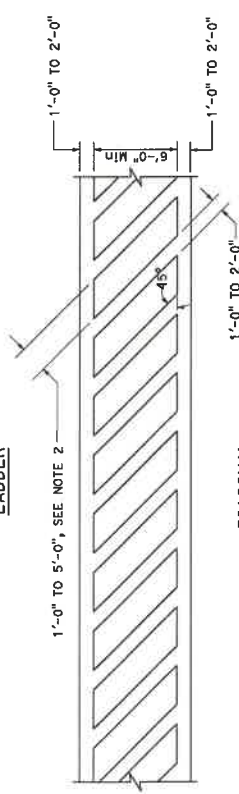

DIAGONAL

HIGHER VISIBILITY CROSSWALKS

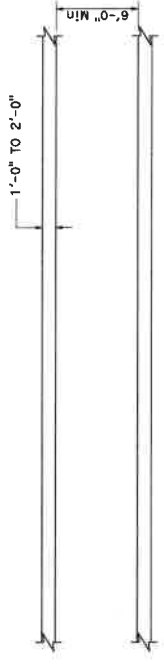

BASIC

STATE OF CALIFORNIA
 DEPARTMENT OF TRANSPORTATION
**PAVEMENT MARKINGS
 CROSSWALKS**
 NO SCALE

A 24F

DIST#	COUNTY	ROUTE	SHEET NO.	TOTAL SHEETS

REGISTERED ELECTRICAL ENGINEER
Conrad M. ...
 PROFESSIONAL ENGINEER
 No. E17982
 EXPIRES 12-31-24
 REGISTERED IN THE STATE OF CALIFORNIA
 THE STATE OF CALIFORNIA OR ITS OFFICERS OR AGENTS SHALL NOT BE RESPONSIBLE FOR ANY ERRORS OR OMISSIONS OR FOR THE CONSEQUENCES OF THIS PLAN SHEET.

September 20, 2024
 PLANS APPROVAL DATE
 REGISTERED ELECTRICAL ENGINEER

- NOTES:**
1. Round corners of acute angle saw cuts to prevent damage to conductors.
 2. Typical distance separating loops from edge to edge is 10' for Type A, B, D, E, and F installation in single lane.
 3. Use Type D and F loops for limit line detection and bicycle lanes.

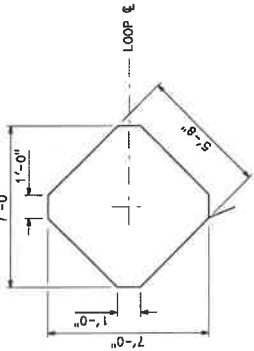

WINDING DETAIL
 TYPE B LOOP DETECTOR CONFIGURATION
 SAW CUT DETAIL

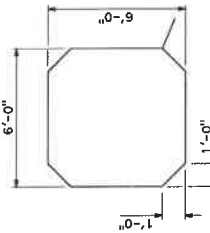
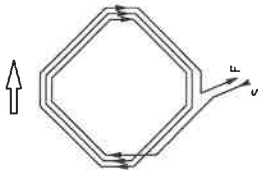

WINDING DETAIL
 TYPE A LOOP DETECTOR CONFIGURATION
 SAW CUT DETAIL

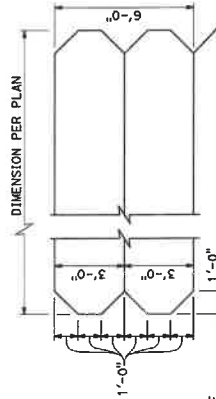
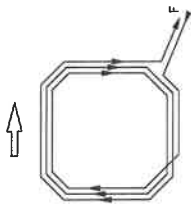

WINDING DETAIL
 TYPE C LOOP DETECTOR CONFIGURATION
 SAW CUT DETAIL

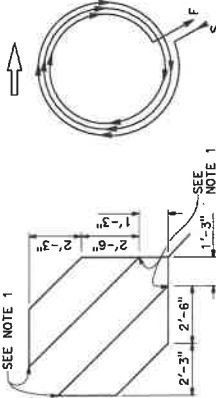
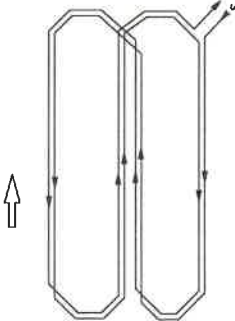

WINDING DETAIL
 TYPE D LOOP DETECTOR CONFIGURATION
 SAW CUT DETAIL

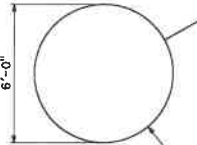
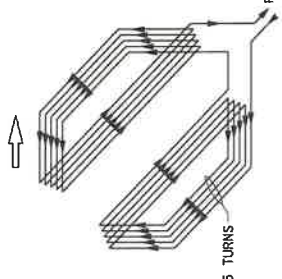

WINDING DETAIL
 TYPE E LOOP DETECTOR CONFIGURATION
 SAW CUT DETAIL

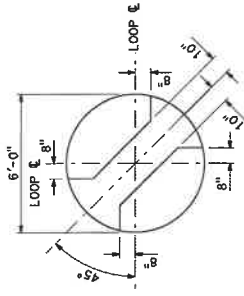

WINDING DETAIL
 TYPE F LOOP DETECTOR CONFIGURATION
 SAW CUT DETAIL

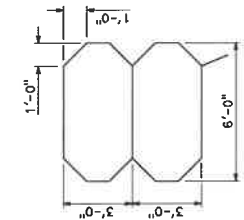
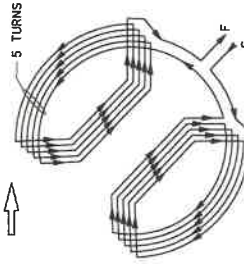

WINDING DETAIL
 TYPE Q LOOP DETECTOR CONFIGURATION
 SAW CUT DETAIL

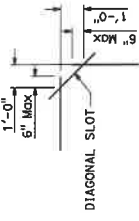
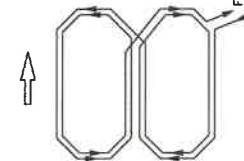

PLAN VIEW OF
 DIAGONAL SLOT
 AT CORNERS

STATE OF CALIFORNIA
 DEPARTMENT OF TRANSPORTATION
**ELECTRICAL SYSTEMS
 (DETECTORS)**
 NO SCALE

ES-5B

EXHIBIT B
INSURANCE REQUIREMENTS

Contractor shall maintain and shall require all of its subcontractors, consultants, and other agents to maintain the insurance listed below. Any requirement for insurance to be maintained after completion of the work shall survive this agreement.

CITY reserves the right to review any and all of the required insurance policies and/or endorsements, but has no obligation to do so. Failure to demand evidence of full compliance with the insurance requirements set forth in this agreement or failure to identify any insurance deficiency shall not relieve Contractor from, nor be construed or deemed a waiver of, its obligation to maintain the required insurance at all times during the performance of this agreement.

A. Workers Compensation & Employers Liability Insurance

- Workers Compensation insurance with statutory limits as required by the Labor Code of the State of California.
- Employers Liability with limits of \$1,000,000 per Accident; \$1,000,000 Disease per employee; \$1,000,000 Disease per policy.
- The policy shall include a written waiver of the insurer's right to subrogate against CITY.
- Required Evidence Of Coverage:
 1. Subrogation waiver endorsement; and
 2. Properly completed Certificate of Insurance.

B. General Liability Insurance

- Commercial General Liability Insurance no less broad than Insurance Services Office (ISO) form CG 00 01.
- Coverage shall be on a standard occurrence form. Claims-Made forms are not acceptable without prior written consent. Modified, limited or restricted Occurrence forms are not acceptable without prior written consent.
- Minimum Limits: \$2,000,000 per Occurrence; \$4,000,000 General Aggregate; \$4,000,000 Products/Completed Operations Aggregate. The General Aggregate shall apply separately to each project. The required limits may be provided by a combination of General Liability Insurance and Commercial Excess or Umbrella Liability Insurance. If contractor maintains higher limits than the specified minimum limits, CITY requires and shall be entitled to coverage for the higher limits maintained by contractor.
- Any deductible or self-insured retention shall be shown on the Certificate of Insurance. If the deductible or self-insured retention exceeds \$25,000 it must be approved in advance by CITY. Contractor is responsible for any deductible or self-insured retention and shall fund it upon CITY'S written request, regardless of whether Contractor has a claim against the insurance or is named as a party in any action involving CITY.
- Coverage shall be continued for one (1) year after completion of the work.
- CITY shall be endorsed as an additional insured for liability arising out of ongoing and completed operations by or on behalf of the contractor. CITY shall continue to be an additional insured for completed operations for (1) year after completion of the work.
- The policy definition of "insured contract" shall include assumptions of liability

arising out of both ongoing operations and the products-completed operations hazard (“P” definition of insured contract in ISO form CG 00 01, or equivalent).

- The insurance provided to the additional insureds shall be primary to, and non-contributory with, any insurance or self-insurance program maintained by them.
- The policy shall cover inter-insured suits and include a “Separation of Insureds” or “severability” clause which treats each insured separately.
- The policy shall be endorsed to include a written waiver of the insurer’s right to subrogate against all persons or entities that are, or are required to be, additional insureds.
- The policy shall not contain a Contractors' Warranty or other similar language which eliminates or restricts insurance because of a subcontractor's failure to carry specific insurance or to supply evidence of such insurance.
- Required Evidence of Coverage:
 1. Copy of the additional insured endorsement or policy language granting additional insured status;
 2. Copy of the endorsement or policy language indicating that coverage applicable to the additional insureds is primary and non-contributory;
 3. Properly completed Certificate of Insurance; and
 4. Completed and signed Agent/Broker Questionnaire with supporting documentation as required.
 5. City of Whittier shall also be listed as additionally insured.

C. Automobile Liability Insurance

- Minimum Limit: \$2,000,000 combined single limit per accident.
- Coverage shall apply to all owned, hired and non-owned vehicles.
- CITY shall qualify as an insured.
- Required Evidence of Coverage:
 1. Copy of the endorsement or policy language indicating that CITY is an insured; and
 2. Properly completed Certificate of Insurance.
 3. City of Whittier shall also be listed as additionally insured.

D. Surety Bonds

- Bid bond.
- Performance and payment bonds for the entire contract price.
- The surety must be authorized to issue these bonds in the State of California.

E. Standards for Insurance Companies

- Insurers, other than the California State Compensation Insurance Fund, shall have an A.M. Best's rating of at least A:VII.

F. Documentation

- The Certificate of Insurance shall include the following reference: [Macy Street Rehabilitation Project. Fiscal Year 2022-2023 City of La Habra Project 1-R-23]
- The name and address for Additional Insured endorsements and Certificates of Insurance is: City of La Habra and City of Whittier

City Project No. 1-R-23

- Contractor shall supply sufficient insurance as set forth by Caltrans and the City of Whittier at no additional cost to the City of La Habra
- Contractor shall provide immediate written notice if: (1) any of the required insurance policies is terminated; (2) the limits of any of the required policies are reduced; or (3) the deductible or self-insured retention is increased.
- Current Evidence of Coverage shall be provided for the entire required period of insurance.
- Upon written request, certified copies of required insurance policies shall be provided within thirty (30) days.

EXHIBIT C

CERTIFICATES OF INSURANCE AND ENDORSEMENTS

EXHIBIT D
CLAIMS PROCEDURE

SUMMARY OF PUBLIC CONTRACT CODE § 9204

The following procedure will apply to any claims by the Contractor on the City:

A “claim” is a separate demand on the City by a contractor on a public works project and sent by registered mail or certified mail with return receipt requested, for one or more of the following:

- A time extension, including relief from penalties for delay
- Payment by the City of money damages under the terms of the contract
- Payment of an amount that is disputed by the City

Initial Review

The claim must be supported by appropriate documentation. The City has 45 days within which to review the claim and provide the contractor with a written statement identifying the disputed and undisputed portions of the claim. If the City does not issue a written statement, the claim is deemed rejected in its entirety. The City will pay any undisputed portion of the claim within 60 days of issuing the statement.

Meet & Confer

If the contractor disputes the City’s written response, or if the City does not issue one, the contractor may request in writing an informal conference to meet and confer for possible settlement of the claim. The City will schedule the meet and confer conference within 30 days of this request and provide a written statement identifying the remaining disputed and undisputed portions of the claim within 10 business days of the meet and confer. The City will pay the undisputed portion within 60 days of issuing this statement.

Mediation

With respect to any disputed portion remaining after the meet and confer, the City and contractor will submit the matter to nonbinding mediation, agree to a mediator within 10 business days after issuing the written statement, and share mediation costs equally. If mediation is unsuccessful, then the terms of the public works agreement and applicable law will govern resolution of the dispute.

Miscellaneous Provisions

Amounts not paid by the City in a timely manner bear interest at 7% per annum. Subcontractors may submit claims via this procedure through the general contractor. The City and contractor may waive the requirement to mediate, but cannot otherwise waive these claim procedures.