

**CITY OF LA HABRA
PUBLIC WORKS AGREEMENT FOR
ANNUAL SIDEWALK IMPROVEMENTS PROJECT FY 24-25**

THIS AGREEMENT (herein "Agreement"), is made and entered into this 3rd day of November, 2025 and between the **CITY OF LA HABRA**, a municipal corporation (herein "City") and **LESLIE GUNNER CAMPBELL CONSTRUCTION**. (herein "Contractor"). The parties hereto agree as follows:

W I T N E S S E T H :

A. WHEREAS, City requires the construction of concrete improvements as set forth more fully in this Agreement.

B. WHEREAS, Contractor represents to City that Contractor is qualified to perform said work and has submitted a proposal to City for the same.

C. WHEREAS, City desires to have Contractor perform said services on the terms and conditions set forth herein.

D. WHEREAS, no official or employee of City has a financial interest, within the provisions of Sections 1090-1092 of the California Government Code, in the subject matter of this Agreement.

NOW, THEREFORE, for and in consideration of the mutual covenants and conditions contained herein and for good and valuable consideration, the receipt and sufficiency of which is acknowledged by both parties, City and Contractor hereby agree as follows:

1.0 DEFINITIONS

1.1 Definitions. As used in this Agreement, the following definitions shall be applicable:

- (a) Contractor. Contractor shall mean **LESLIE GUNNER CAMPBELL CONSTRUCTION**., a California corporation located at 22313 San Joaquin Drive West Canyon Lake, CA 92587.
- (b) City. City shall mean the City of La Habra, a Municipal Corporation and General Law City, located at 110 E. La Habra Blvd, La Habra, California 90631.
- (c) City Council. City Council shall mean the City Council of the City of La Habra.
- (d) Contract Officer shall mean the person designated by the City Manager or City Engineer of City and shall have the duties set forth in Section 5.2.
- (e) Services. Services shall mean the services to be performed by the Contractor pursuant to this Agreement.
- (f) Satisfactory. Satisfactory shall mean satisfactory to the City Manager or his/her designee.

2.0 SERVICES OF CONTRACTOR

2.1 Scope of Services. In compliance with all terms and conditions of this Agreement, the Contractor shall provide those services specified in the "Scope of Services" attached hereto as Exhibit "A" and incorporated herein by this reference, which services may be referred to herein as the "services" or "work" hereunder. As a material inducement to the City entering into this Agreement, Contractor represents and warrants that Contractor is a provider of first class work and services and Contractor is experienced in performing the work and services contemplated herein and, in light of such status and experience, Contractor covenants that it shall follow the highest professional standards in performing the work and services required hereunder and that all materials will be of good quality, fit for the purpose intended.

2.2 Documents Included in Contract. This contract consists of this Agreement and any Exhibits, which are incorporated herein by this reference. In the event of an inconsistency, the terms of this Agreement shall govern.

2.3 Compliance with Law. All services rendered hereunder shall be provided in accordance with all ordinances, resolutions, statutes, rules, and regulations of the City and any Federal, State or local governmental agency having jurisdiction in effect at the time service is rendered, including but not limited to, the claims procedure set forth in Public Contract Code Section 9204, a summary of which is attached to this agreement as Exhibit "D."

2.4 Licenses, Permits, Fees and Assessments. Contractor shall obtain at its sole cost and expense such licenses, permits and approvals as may be required by law for the performance of the services required by this Agreement, including registration with the Department of Industrial Relations of the State of California as required by Labor Code Section 1725.5 before commencing performance under this Agreement. Contractor shall have the sole obligation to pay for any fees, assessments and taxes, plus applicable penalties and interest, which may be imposed by law and arise from or are necessary for the Contractor's performance of the services required by this Agreement, and shall indemnify, defend and hold harmless City against any such fees, assessments, taxes penalties or interest levied, assessed or imposed against City hereunder. Contractor shall be responsible for all subcontractors' compliance with this Section 2.4.

2.5 Familiarity with Work. By executing this Contract, Contractor warrants that Contractor (a) has thoroughly investigated and considered the scope of services to be performed, (b) has carefully considered how the services should be performed, and (c) fully understands the facilities, difficulties and restrictions attending performance of the services under this Agreement. If the services involve work upon any site, Contractor warrants that Contractor has or will investigate the site and is or will be fully acquainted with the conditions there existing, prior to commencement of services hereunder. Should Contractor discover any latent or unknown conditions, which will materially affect the performance of the services hereunder, Contractor shall immediately inform the City of such fact and shall not proceed except at Contractor's risk until written instructions are received from the Contract Officer.

2.6 Standard of Performance. Contractor, its subcontractors and their employees, in the performance of Contractor's work under this Agreement shall be responsible for exercising the degree of skill and care required by customarily accepted good professional practices and procedures used in the Contractor's field.

Any costs for failure to meet the foregoing standard or to correct otherwise defective work that requires re-performance of the work, shall be borne in total by the Contractor and not by the City. The failure of a

project to achieve the performance goals and objectives stated in this Agreement is not a basis for requesting re-performance unless the work conducted by Contractor and/or its subcontractors is deemed by the City to have failed the foregoing standard of performance.

In the event Contractor fails to perform in accordance with the above standard:

1. Contractor will re-perform, at its own expense, any task which was not performed to the reasonable satisfaction of City. Any work re-performed pursuant to this paragraph shall be completed within the time limitations originally set forth for the specific task involved. Contractor shall work any overtime required to meet the deadline for the task at no additional cost to the City;
2. The City shall provide a new schedule for the re-performance of any task pursuant to this paragraph in the event that re-performance of a task within the original time limitations is not feasible; and
3. The City shall have the option to direct Contractor not to re-perform any task which was not performed to the reasonable satisfaction of the City Engineer pursuant to application of (1) and (2) above. In the event the City directs Contractor not to re-perform a task, the City shall negotiate a reasonable settlement for satisfactory work performed. No previous payment shall be considered a waiver of the City's right to reimbursement.

Nothing contained in this section is intended to limit any of the rights or remedies which the City may have under law.

2.7 Care of Work. The Contractor shall adopt reasonable methods during the life of the Agreement to furnish continuous protection to the work, and the equipment, materials, papers, documents, plans, studies and/or other components thereof to prevent losses or damages, and shall be responsible for all such damages, to persons or property, until acceptance of the work by City, except such losses or damages as may be caused by City's own negligence.

2.8 Further Responsibilities of Parties. Both parties agree to use reasonable care and diligence to perform their respective obligations under this Agreement. Both parties agree to act in good faith to execute all instruments, prepare all documents and take all actions as may be reasonably necessary to carry out the purposes of this Agreement. Unless hereafter specified, neither party shall be responsible for the service of the other. Contractor shall require all subcontractors to comply with the provisions of this agreement.

2.9 Additional Services. City shall have the right at any time during the performance of the services, without invalidating this Agreement, to order extra work beyond that specified in the Scope of Services or make changes by altering, adding to or deducting from said work. No such extra work may be undertaken unless a written change order is first given by the Contract Officer to the Contractor, incorporating therein any adjustment in (i) the Contract Sum as set forth in Section 3.1, and/or (ii) the time to perform this Agreement, which said adjustments are subject to the written approval of the Contractor. Any increase in compensation of twenty five percent (25%) or less of the Contract Sum, or in the time to perform of one hundred eighty (180) days or less may be approved by the Contract Officer. Any increases, taken either separately or cumulatively, that result in the Contract Sum exceeding \$25,000 must be approved by the City Council. It is expressly understood by Contractor that the provisions of this Section shall not apply to services specifically set forth in the Scope of Services or reasonably contemplated therein. Contractor hereby acknowledges that it accepts the risk that the services to be provided pursuant to the Scope of Services may be more costly or time consuming than Contractor anticipates and that Contractor shall not be entitled to additional compensation therefore.

2.10 Prevailing Wage Laws. Contractor represents and warrants that it is registered with the Department of Industrial Relations pursuant to SB 854 and Labor Code 1725.5. Contractor shall ensure that its subcontractors comply with said requirements. In accordance with Labor Code Section 1770 et seq., the Director of the Department of Industrial Relations of the State of California has ascertained a general prevailing rate of wages, which is the minimum amount, which shall be paid to all workers employed to perform the work pursuant to this Agreement. A copy of the general prevailing wage rate determination is on file in the Office of the City Clerk and is hereby incorporated by reference into this Agreement. In accordance with the provisions of Labor Code Section 1810 et seq., eight (8) hours is the legal working day. Contractor must forfeit to the City Twenty Five Dollars (\$25.00) a day for each worker who works in excess of the minimum working hours when Contractor does not pay overtime. Contractor is required to post a copy of such wage rates at all times at the contract site. The statutory penalties for failure to pay prevailing wage or to comply with State wage and hour laws will be enforced. Contractor also shall comply with State law requirements to maintain payroll records and shall provide for certified records and inspection of records as required by California Labor Code Section 1770 et. seq., including Section 1776. Contractor shall comply with all statutory requirements relating to the employment of apprentices.

3.0 COMPENSATION

3.1 Contract Sum. For the services rendered pursuant to this Agreement, the Contractor shall be compensated as specified herein, but not exceeding the maximum contract amount of One Hundred Thirty Five Thousand Five Hundred Fifty Dollars (\$135,550) (herein "Contract Sum"), except as provided in Section 2.9. The Contract Sum shall include the attendance of Contractor at all project meetings reasonably deemed necessary by the City; Contractor shall not be entitled to any additional compensation for attending said meetings.

3.2 Progress Payments. Prior to the first day of the month, during the progress of the work, commencing on the day and month specified in the Agreement, Contractor shall submit to the Contract Officer a complete itemized statement of all labor and materials incorporated into the work during the preceding month and the portion of the contract sum applicable thereto. Upon approval in writing by the Contract Officer, payment shall be made in thirty (30) days. City shall pay Contractor a sum based upon ninety-five percent (95%) of the contract price apportionment of the labor and materials incorporated into the work under the contract during the month covered by said statement. The remaining five percent (5%) thereof shall be retained as performance security. Refer to Section 8.4 of this Agreement for retention of funds.

4.0 PERFORMANCE SCHEDULE

4.1 Time of Essence. Time is of the essence in the performance of this Agreement.

4.2 Schedule of Performance. Contractor shall commence the services pursuant to this Agreement upon receipt of a written notice to proceed and shall perform all services within the time period(s) established in Exhibit "A", and incorporated herein by this reference. When requested by the Contractor, extensions to the time period(s) specified in the Scope of Services may be approved in writing by the Contract Officer.

4.3 Force Majeure. The time period(s) specified in the Scope of Services for performance of the services rendered pursuant to this Agreement shall be extended because of any delays due to unforeseeable causes beyond the control and without the fault or negligence of the Contractor, including, but not restricted to, acts of God or of the public enemy, unusually severe weather, fires, earthquakes, floods, epidemics, quarantine restrictions, riots, strikes, freight embargoes, wars, litigation, and/or acts of any governmental agency, including

the City, if the Contractor shall within ten (10) days of the commencement of such delay notify the Contract Officer in writing of the causes for the delay. The Contract Officer shall ascertain the facts and the extent of delay, and extend the time for performing the services for the period of the enforced delay when and if in the judgment of the Contract Officer such delay is justified. The Contract Officer's determination shall be final and conclusive upon the parties to this Agreement.

4.4 Term. Unless earlier terminated in accordance with Section 8.9 of this Agreement, this Agreement shall continue in full force and effect until final approval and acceptance of the project by the Contract Officer. Notwithstanding the foregoing, this Agreement shall terminate no later than November 3, 2026, unless the parties mutually agree in writing to extend the term.

5.0 COORDINATION OF WORK

5.1 Representative of Contractor. The following principals of Contractor are hereby designated as being the principals and representatives of Contractor authorized to act in its behalf with respect to the work specified herein and make all decisions in connection therewith:

Leslie Campbell
22313 San Joaquin Drive West
Canyon Lake, CA 92587

It is expressly understood that the experience, knowledge, capability and reputation of the foregoing principals were a substantial inducement for City to enter into this Agreement. Therefore, the foregoing principals shall be responsible during the term of this Agreement for directing all activities of Contractor and devoting sufficient time to personally supervise the services hereunder. For purposes of this Agreement, the foregoing principals may not be replaced nor may their responsibilities be substantially reduced by Contractor without the express written approval of City.

5.2 Contract Officer. The Contract Officer shall be such person as may be designated by the City Manager or City Engineer of City. It shall be the Contractor's responsibility to assure that the Contract Officer is kept informed of the progress of the performance of the services and the Contractor shall refer any decisions that must be made by City to the Contract Officer. Unless otherwise specified herein, any approval of City required hereunder shall mean the approval of the Contract Officer. The Contract Officer shall have authority to sign all documents on behalf of the City required hereunder to carry out the terms of this Agreement.

5.3 Prohibition Against Assignment. The experience, knowledge, capability and reputation of Contractor, its principals and employees were a substantial inducement for the City to enter into this Agreement. Neither this Agreement nor any interest herein may be transferred, assigned, conveyed, hypothecated or encumbered voluntarily or by operation of law, whether for the benefit of creditors or otherwise, without the prior written approval of City. Transfers restricted hereunder shall include the transfer to any person or group of persons acting in concert of more than twenty five percent (25%) of the present ownership and/or control of Contractor, taking all transfers into account on a cumulative basis. In the event of any such unapproved transfer, including any bankruptcy proceeding, this Agreement shall be void. No approved transfer shall release the Contractor or any surety of Contractor of any liability hereunder without the express consent of City.

5.4 Independent Contractor. Neither the City nor any of its employees shall have any control over the manner, mode or means by which Contractor, its subcontractors, agents or employees, performs the services required herein, except as otherwise set forth herein. City shall have no voice in the

selection, discharge, supervision or control of Contractor's employees, subcontractors, servants, representatives or agents, or in fixing their number, compensation or hours of service. Contractor shall perform all services required herein as an independent contractor of City and shall remain at all times as to City a wholly independent contractor with only such obligations as are consistent with that role. Contractor shall not at any time or in any manner represent that it or any of its subcontractors, agents or employees are agents or employees of City. City shall not in any way or for any purpose become or be deemed to be a partner of Contractor in its business or otherwise or a joint venture or a member of any joint enterprise with Contractor.

5.5 Identity of Persons Performing Work. Contractor represents that it employs or will employ at its own expense all personnel required for the satisfactory performance of any and all tasks and services set forth herein. Contractor represents that the tasks and services required herein will be performed by Contractor or under its direct supervision, and that all personnel engaged in such work shall be fully qualified and shall be authorized and permitted under applicable State and local law to perform such tasks and services.

5.6 Utility Relocation. City is responsible for removal, relocation, or protection of existing main or trunkline utilities to the extent such utilities were not identified in the invitation for bids or specifications. City shall reimburse contractor for any costs incurred in locating, repairing damage not caused by contractor and removing or relocating such unidentified utility facilities, including equipment idled during such work. Contractor shall not be assessed liquidated damages for delay arising from the removal or relocation of such unidentified utility facilities.

5.7 Trenches or Excavations. Pursuant to California Public Contract Code Section 7104, in the event the work included in this Agreement requires excavations more than four (4) feet in depth, the following shall apply.

- (a) Contractor shall promptly, and before the following conditions are disturbed, notify City, in writing, of any: (1) material that Contractor believes may be material that is hazardous waste, as defined in Section 25117 of the Health and Safety Code, that is required to be removed to a Class I, Class II, or Class III disposal site in accordance with provisions of existing law; (2) Subsurface or latent physical conditions at the site different from those indicated; or (3) Unknown physical conditions at the site of any unusual nature, different materially from those ordinarily encountered and generally recognized as inherent in work of the character provided for in the contract.
- (b) City shall promptly investigate the conditions, and if it finds that the conditions do materially so differ, or do involve hazardous waste, and cause a decrease or increase in Contractor's cost of, or the time required for, performance of any part of the work shall issue a change order per Section 2.9 of this Agreement.
- (c) That, in the event that a dispute arises between City and Contractor whether the conditions materially differ, or involve hazardous waste, or cause a decrease or increase in Contractor's cost of, or time required for, performance of any part of the work, Contractor shall not be excused from any scheduled completion date provided for by the contract, but shall proceed with all work to be performed under the contract. Contractor shall retain any and all rights provided either by contract or by law, which pertain to the resolution of disputes and protests between the contracting parties.

6.0 INSURANCE, INDEMNIFICATION AND BONDS

6.1 Insurance. The Contractor and all subcontractors, if any, shall procure and maintain, at its sole cost and expense, in a form and content satisfactory to City, during the entire term of this Agreement including any extension thereof, insurance as set forth in Exhibit "B" attached hereto and incorporated herein by this reference.

Conditions:

The insurance of surety companies who provide or issue the policy shall have been admitted to do business in the State of California with a credit rating of A- or better.

This insurance shall not be canceled, limited in scope or coverage or non-renewed until after thirty (30) days prior written notice has been given to the Public Works Director, City of La Habra, 110 E. La Habra Blvd., La Habra, California 90631.

Any insurance maintained by the City of La Habra shall apply in excess of and not combined with insurance provided by this policy.

The City of La Habra, its officers, employees, representatives, attorneys, and volunteers shall be named as additional named insureds.

Prior to commencement of any work under this contract, Contractor shall deliver to the City insurance endorsements confirming the existence of the insurance required by this contract, and including the applicable clauses referenced above.

Such endorsements shall be signed by an authorized representative of the insurance company and shall include the signator's company affiliation and title. Should it be deemed necessary by the City, it shall be Contractor's responsibility to see that the City receives documentation, acceptable to the City, which sustains that the individual signing said endorsements is indeed authorized to do so by the insurance company.

If the Contractor fails to maintain the aforementioned insurance, or secure and maintain the aforementioned endorsement, the City may obtain such insurance, and deduct and retain the amount of the premiums for such insurance from any sums due under the agreement. However, procuring of said insurance by the City is an alternative to other remedies the City may have, and is not the exclusive remedy for failure of Contractor to maintain said insurance or secure said endorsement. In addition to any other remedies the City may have upon Contractor's failure to provide and maintain any insurance or policy endorsements to the extent and within the time herein required, the City shall have the right to order Contractor to stop work hereunder, and/or withhold any payment(s) which became due to Contractor hereunder until Contractor demonstrates compliance with the requirements hereof.

Nothing herein contained shall be construed as limiting in any way the extent to which Contractor may be held responsible for payments of damages to persons or property resulting from Contractor's or its subcontractor's performance of the work covered under this agreement.

Each contract between the Contractor and any subcontractor shall require the subcontractor to maintain the same policies of insurance that the Contractor is required to maintain pursuant to this Section 6.1 and Exhibit "B".

6.2 Certificates of Insurance. Contractor shall provide to City certificates of insurance showing the insurance coverages and required endorsements described above, in a form and content approved by City, prior to performing any services under this Agreement. The certificates of insurance and endorsements shall be attached to this Agreement as Exhibit "C", and are incorporated herein by this reference.

6.3 Indemnification. Contractor shall defend, indemnify, hold free and harmless the City of La Habra, its elected and appointed officials, officers, agents and employees, at Contractor's sole expense, from and against any and all actions, suits, claims, damages to persons or property, losses, costs, penalties, obligations, errors, omissions or liabilities, (herein "claims or liabilities") that may be asserted or claimed by any person, firm or entity arising or alleged to arise out of or in connection with the performance of the work, operations or activities of Contractor, its agents, employees, subcontractors, or invitees, provided for herein, or arising or alleged to arise from the negligent acts or omissions of Contractor hereunder, or arising or alleged to arise from Contractor's performance of or failure to perform any term, provision, covenant or condition of this Agreement.

- (a) Contractor will defend any action or actions filed in connection with any of said claims or liabilities and will pay all costs and expenses, including legal costs and attorneys' fees incurred in connection therewith.
- (b) Contractor will promptly pay any judgment rendered against the City, its officers, agents or employees for any such claims or liabilities arising or alleged to arise out of or in connection with Contractor's (or its agents', employees', subcontractors' or invitees') negligent performance of or failure to perform such work, operations or activities hereunder; and Contractor agrees to save and hold the City, its officers, agents, and employees harmless therefrom.
- (c) In the event the City, its officers, agents or employees is made a party to any action or proceeding filed or prosecuted against Contractor for such damages or other claims arising or alleged to arise out of or in connection with the performance of or failure to perform the work, operation or activities of Contractor hereunder, Contractor shall pay to the City, its officers, agents or employees, any and all costs and expenses incurred by the City, its officers, agents or employees in such action or proceeding, including but not limited to, legal costs and attorneys' fees for counsel selected by City.
- (d) Contractor's duty to defend and indemnify as set out in this Section 6.3 shall include any claims, liabilities, obligations, losses, demands, actions, penalties, suits, costs, expenses or damages or injury to persons or property arising or alleged to arise from, in connection with, as a consequence of or pursuant to any state or federal law or regulation regarding hazardous substances, including but not limited to the Federal Insecticide, Fungicide and Rodenticide Act ("FIFRA"), Comprehensive Environmental Response, Compensation and Liability Act of 1980 ("CERCLA"), Resource Conservation and Recovery Act of 1976 ("RCRA"), the Hazardous and Solid Waste Amendments of 1984, the Hazardous Material Transportation Act, the Toxic Substances control Act, the Clean Air Act, the Clean Water Act, the California Hazardous Substance Account Act, the California Hazardous Waste Control Law or the Porter-Cologne Water Quality Control Act, as any of those statutes may be amended from time to time.

Notwithstanding the foregoing, Contractor shall not be liable for the defense or indemnification of the City for claims, actions, complaints or suits arising out of the sole active negligence or willful misconduct of the City.

The Contractor's indemnification obligations pursuant to this Section 6.3 shall survive the termination of this Agreement. Contractor shall require the same indemnification from all subcontractors.

6.4 Labor and Materials and Performance Bonds. Concurrently with execution of this Agreement, Contractor shall deliver to City a labor and materials bond and a performance bond each in the sum of the amount of this Agreement, in the forms provided by the City Clerk, which secures the faithful performance of this Agreement. The bonds shall contain the original notarized signature of an authorized officer of the surety and affixed thereto shall be a certified and current copy of his power of attorney. The bonds shall be unconditional and remain in force during the entire term of the Agreement and shall be null and void only if the Contractor promptly and faithfully performs all terms and conditions of this Agreement.

6.5 Sufficiency of Insurer or Surety. Insurance required by this Agreement shall be satisfactory only if issued by companies qualified to do business in California, rated "A" or better in the most recent edition of Best Rating Guide, The Key Rating Guide or in the Federal Register, and only if they are of a financial category Class VII or better, unless such requirements are waived by the Risk Manager of the City due to unique circumstances.

6.6 Substitution of Securities. Pursuant to California Public Contract Code Section 22300, substitution of eligible equivalent securities for any monies withheld to ensure performance under the contract for the work to be performed will be permitted at the request and expense of the successful bidder.

7.0 RECORDS AND REPORTS

7.1 Reports. Contractor shall periodically prepare and submit to the Contract Officer such reports concerning the performance of the services required by this Agreement as the Contract Officer shall require. Contractor hereby acknowledges that the City is greatly concerned about the cost of work and services to be performed pursuant to this Agreement. For this reason, Contractor agrees that if Contractor becomes aware of any facts, circumstances, techniques, or events that may or will materially increase or decrease the cost of the work or services contemplated herein or, if Contractor is providing design services, the cost of the project being designed, Contractor shall promptly notify the Contract Officer of said fact, circumstance, technique or event and the estimated increased or decreased cost related thereto and, if Contractor is providing design services, the estimated increased or decreased cost estimate for the project being designed.

7.2 Records. Contractor shall keep, and require subcontractors to keep, such books and records (including but not limited to payroll records as required herein) as shall be necessary to perform the services required by this Agreement and enable the Contract Officer to evaluate the performance of such services. The Contract Officer shall have full and free access to such books and records at all times during normal business hours of City, including the right to inspect, copy, audit and make records and transcripts from such records. Such records shall be maintained for a period of three (3) years following completion of the services hereunder, and the City shall have access to such records in the event any audit is required.

7.3 Ownership of Documents. All drawings, specifications, reports, records, documents and other materials prepared by Contractor, its employees, subcontractors and agents in the performance of this Agreement shall be the property of City and shall be delivered to City upon request of the Contract Officer or upon the termination of this Agreement, and Contractor shall have no claim for further employment or additional compensation as a result of the exercise by City of its full rights of ownership of the documents and materials hereunder. Contractor may retain copies of such documents for its own use. Contractor shall have an unrestricted right to use the concepts embodied therein. All subcontractors shall

provide for assignment to City of any documents or materials prepared by them, and in the event Contractor fails to secure such assignment, Contractor shall indemnify City for all damages resulting therefrom.

7.4 Public Records Act Disclosure. Contractor has been advised and is aware that this Agreement and all reports, documents, information and data, including, but not limited to, computer tapes, discs or files furnished or prepared by Contractor, or any of its subcontractors, pursuant to this Agreement and provided to City may be subject to public disclosure as required by the California Public Records Act (California Government Code Section 7920.000 *et seq.*). Exceptions to public disclosure may be those documents or information that qualify as trade secrets, as that term is defined in the California Government Code Section 7924.510, and of which Contractor informs City of such trade secret. The City will endeavor to maintain as confidential all information obtained by it that is designated as a trade secret. The City shall not, in any way, be liable or responsible for the disclosure of any trade secret including, without limitation, those records so marked if disclosure is deemed to be required by law or by order of the Court.

8.0 GENERAL PROVISIONS

8.1 Governing Law. This Agreement shall be construed and interpreted both as to validity and to performance of the parties in accordance with the laws of the State of California. Legal actions concerning any dispute, claim or matter arising out of or in relation to this Agreement shall be instituted in the Superior Court of the County of Orange, State of California, or any other appropriate court in such county, and Contractor covenants and agrees to submit to the personal jurisdiction of such court in the event of such action.

8.2 Representatives. The City Manager or his or her designee shall be the representative of City for purposes of this Agreement and may issue all consents, approvals, directives and agreements on behalf of the City, called for by this Agreement, except as otherwise expressly provided in this Agreement.

The Principal set forth in Section 5.1 above shall be the representative for Contractor for purposes of this Agreement, and shall be authorized to issue all consents, approvals, directives and agreements on behalf of Contractor called for by this Agreement, except as otherwise expressly provided in this Agreement.

8.3 Disputes. In the event either party fails to perform its obligations hereunder, the nondefaulting party shall provide the defaulting party written notice of such default. The defaulting party shall have ten (10) days to cure the default; provided that, if the default is not reasonably susceptible to being cured within said ten (10) day period, the defaulting party shall have a reasonable time to cure the default, not to exceed a maximum of thirty (30) days, so long as the defaulting party commences to cure such default within ten (10) days of service of such notice and diligently prosecutes the cure to completion; provided further that if the default is an immediate danger to the health, safety and general welfare, the defaulting party shall take such immediate action as may be necessary. Notwithstanding the foregoing, the nondefaulting party may, in its sole and absolute discretion, grant a longer cure period. Should the defaulting party fail to cure the default within the time period provided in this Section, the nondefaulting party shall have the right, in addition to any other rights the nondefaulting party may have at law or in equity, to terminate this Agreement. Compliance with the provisions of this Section 8.3 shall be a condition precedent to bringing any legal action, and such compliance shall not be a waiver of any party's right to take legal action in the event that the dispute is not cured.

8.4 Retention of Funds. Progress payments shall be made in accordance with the provisions of Section 3.2 of this Agreement. In accordance with said section, City shall pay Contractor a sum based upon ninety-five percent (95%) of the contract price apportionment of the labor and materials

incorporated into the work under the contract during the month covered by said statement. The remaining five percent (5%) thereof shall be retained as performance security to be paid to the Contractor within sixty (60) days after final acceptance of the work by the City Council, after Contractor shall have furnished City with a release of all undisputed contract amounts if required by City. In the event there are any claims specifically excluded by Contractor from the operation of the release, the City may retain proceeds (per Public Contract Code 7107) of up to 150% of the amount in dispute. City's failure to deduct or withhold shall not affect Contractor's obligations hereunder.

8.5 Waiver. No delay or omission in the exercise of any right or remedy by a nondefaulting party on any default shall impair such right or remedy or be construed as a waiver. A party's consent to or approval of any act by the other party requiring the party's consent or approval shall not be deemed to waive or render unnecessary the other party's consent to or approval of any subsequent act. Any waiver by either party of any default must be in writing and shall not be a waiver of any other default concerning the same or any other provision of this Agreement.

8.6 Rights and Remedies. Rights and Remedies are cumulative except with respect to rights and remedies expressly declared to be exclusive in this Agreement, the rights and remedies of the parties are cumulative and the exercise by either party of one or more of such rights or remedies shall not preclude the exercise by it, at the same or different times, of any other rights or remedies for the same default or any other default by the other party.

8.7 Legal Action. In addition to any other rights or remedies, either party may take legal action, in law or in equity, to cure, correct or remedy any default, to recover damages for any default, to compel specific performance of this Agreement, to obtain declaratory or injunctive relief, or to obtain any other remedy consistent with the purposes of this Agreement.

8.8 Liquidated Damages. Since the determination of actual damages for any delay in performance of this Agreement would be extremely difficult or impractical to determine in the event of a breach of this Agreement, the Contractor and its sureties shall be liable for and shall pay to the City Five Hundred Dollars (\$500.00) as liquidated damages for each working day of delay in the performance of any service required hereunder, as specified in the Scope of Services (Exhibit "A"). The City may withhold from any monies payable on account of services performed by the Contractor any accrued liquidated damages.

8.9 Termination for Default of Contractor. If termination is due to the failure of the Contractor to fulfill its obligations under this Agreement, Contractor shall vacate any City owned property which Contractor is permitted to occupy hereunder and City may, after compliance with the provisions of Section 8.3, take over the work and prosecute the same to completion by contract or otherwise, and the Contractor shall be liable to the extent that the total cost for completion of the services required hereunder exceeds the compensation herein stipulated (provided that the City shall use reasonable efforts to mitigate such damages), and City may withhold any payments to the Contractor for the purpose of setoff or partial payment of the amounts owed the City as previously stated.

8.10 Notice. Any notice, demand, request, document, consent, approval, or communication either party desires or is required to give to the other party or any other person shall be in writing and shall be deemed to be given when served personally or deposited in the US Mail, prepaid, first-class mail, return receipt requested, addressed as follows:

To City: City of La Habra
110 E. La Habra Blvd
La Habra, California 90631

City Project No. 1-R-25.

Attn.: Elias Saykali

To Contractor:

Leslie Gunner
22313 San Joaquin Drive West
Canyon Lake, CA 92587

8.11 Non-liability of City Officers and Employees. No officer or employee of the City shall be personally liable to the Contractor, or any successor in interest, in the event of any default or breach by the City or for any amount which may become due to the Contractor or to its successor, or for breach of any obligation of the terms of this Agreement.

8.12 Conflict of Interest. The Contractor warrants that it has not paid or given and will not pay or give any third party any money or other consideration for obtaining this Agreement.

Contractor and its officers, employees, associates and subcontractors, if any, will comply with all conflict of interest statutes of the State of California applicable to Contractor's services under this agreement, including, but not limited to, the Political Reform Act (Government Code Sections 81000, *et seq.*) and Government Code Section 1090. During the term of this Agreement, Contractor and its officers, employees, associates and subcontractor shall not, without the prior written approval of the City Representative, perform work for another person or entity for whom Contractor is not currently performing work that would require Contractor or one of its officers, employees, associates or subcontractors to abstain from a decision under this Agreement pursuant to a conflict of interest statute.

8.13 Covenant Against Discrimination. Contractor covenants that, by and for itself, its heirs, executors, assigns, and all persons claiming under or through them, that there shall be no discrimination against or segregation of, any person or group of persons on account of race, color, creed, religion, sex, marital status, national origin, or ancestry in the performance of this Agreement. To the extent required by law, contractor shall take affirmative action to insure that applicants are employed and that employees are treated during employment without regard to their race, color, creed, religion, sex, marital status, national origin, or ancestry.

8.14 Interpretation. The terms of this Agreement shall be construed in accordance with the meaning of the language used and shall not be construed for or against either party by reason of the authorship of this Agreement or any other rule of construction which might otherwise apply.

8.15 Severability. In the event that any one or more of the phrases, sentences, clauses, paragraphs, or sections contained in this Agreement shall be declared invalid or unenforceable by a valid judgment or decree of a court of competent jurisdiction, such invalidity or unenforceability shall not affect any of the remaining phrases, sentences, clauses, paragraphs, or sections of this Agreement which are hereby declared as severable and shall be interpreted to carry out the intent of the parties hereunder unless the invalid provision is so material that its invalidity deprives either party of the basic benefit of their bargain or renders this Agreement meaningless.

8.16 [reserved]

8.17 Unfair Business Practices Claims. In entering into a public works contract or a subcontract to supply goods, services or materials pursuant to a public works contract, the contractor or subcontractor offers and agrees to assign to the awarding body all rights, title, and interest in and to all causes of action it may have under Section 4 of the Clayton Act (15 U.S.C. Sec. 15) or under the Cartwright

Act (Chapter 2, (commencing with Section 16700) of Part 2 of Division 7 of the Business and Professions Code), arising from purchases of goods, services or materials pursuant to the public works contract or the subcontract. This assignment shall be made and become effective at the time the awarding body renders final payment to the contractor without further acknowledgment by the parties. (Sec. 7103.5, California Public Contract Code).

8.18 Corporate Authority. The persons executing this Agreement on behalf of the parties hereto warrant that (i) such party is duly organized and existing, (ii) they are duly authorized to execute and deliver this Agreement on behalf of said party, (iii) by so executing this Agreement, such party is formally bound to the provisions of this Agreement, and (iv) the entering into this Agreement does not violate any provision of any other Agreement to which said party is bound.

8.19 PERS Eligibility Indemnification. In the event that Contractor or any employee, agent, or subcontractor of Contractor providing services under this Agreement claims or is determined by a court of competent jurisdiction or the California Public Employees Retirement System (PERS) to be eligible for enrollment in PERS as an employee of the City, Contractor shall indemnify, defend, and hold harmless City for the payment of any employee and/or employer contributions for PERS benefits on behalf of Contractor or its employees, agents, or subcontractors, as well as for the payment of any penalties and interest on such contributions, which would otherwise be the responsibility of City.

Notwithstanding any other agency, state or federal policy, rule, regulation, law or ordinance to the contrary, Contractor and any of its employees, agents, and subcontractors providing service under this Agreement shall not qualify for or become entitled to, and hereby agree to waive any claims to, any compensation, benefit, or any incident of employment by City, including but not limited to eligibility to enroll in PERS as an employee of City and entitlement to any contribution to be paid by City for employer contribution and/or employee contributions for PERS benefits.

8.20 Cooperation. In the event any claim or action is brought against City relating to Contractor's performance or services rendered under this Agreement, Contractor shall render any reasonable assistance and cooperation which City might require.

8.21 Legal Responsibilities. The Contractor shall keep itself informed of City, State, and Federal laws, ordinances and regulations, which may in any manner affect the performance of its services pursuant to this Agreement. The Contractor shall at all times observe and comply with all such laws, ordinances and regulations. Neither the City, nor its officers, agents, or employees shall be liable at law or in equity as a result of the Contractor's failure to comply with this section.

8.22 Termination for Convenience. The City may terminate this Agreement without cause for convenience of the City upon giving contractor 30 days prior written notice of termination of the Agreement. Upon receipt of the notice of termination the Contractor shall cease all further work pursuant to the Agreement. Upon such termination by the City the Contractor shall not be entitled to any other remedies, claims, actions, profits, or damages except as provided in this paragraph. Upon the receipt of such notice of termination Contractor shall be entitled to the following compensation:

1. The contract value of the work completed to and including the date of receipt of the notice of termination, less the amount of progress payments received by contractor.
2. Actual move-off costs including labor, rental fees, equipment transportation costs, the costs of maintaining on-site construction office for supervising the mover-off.

3. The cost of materials custom made for this Agreement which cannot be used by the Contractor in the normal course of his business, and which have not been paid for by City in progress payments.

4. All costs shall not include any markups as might otherwise be allowed by any plans or specifications which were a part of the Agreement.

The provisions of this paragraph shall supersede any other provision of the Agreement or any provision of any plans, specification, addendums or other documents which are or may become a part of this Agreement. City and Contractor agree that the provisions of this paragraph are a substantive part of the consideration for this Agreement.

8.23 Responsibility for Errors. Contractor shall be responsible for its work and results under this Agreement. Contractor, when requested, shall furnish clarification and/or explanation as may be required by the City's representative, regarding any services rendered under this Agreement at no additional cost to City. In the event that an error or omission attributable to Contractor occurs, then Contractor shall, at no cost to City, provide all necessary design drawings, estimates and other Contractor professional services necessary to rectify and correct the matter to the sole satisfaction of City and to participate in any meeting required with regard to the correction.

8.24 Order of Precedence. In the event of an inconsistency in this Agreement and any of the attached Exhibits, the terms set forth in this Agreement shall prevail. If, and to the extent this Agreement incorporates by reference any provision of any document, such provision shall be deemed a part of this Agreement. Nevertheless, if there is any conflict among the terms and conditions of this Agreement and those of any such provision or provisions so incorporated by reference, this Agreement shall govern over the document referenced.

8.25 Costs. Each party shall bear its own costs and fees incurred in the preparation and negotiation of this Agreement and in the performance of its obligations hereunder except as expressly provided herein.

8.26 No Third Party Beneficiary Rights. This Agreement is entered into for the sole benefit of City and Contractor and no other parties are intended to be direct or incidental beneficiaries of this Agreement and no third party shall have any right in, under or to this Agreement.

8.27 Headings. Paragraphs and subparagraph headings contained in this Agreement are included solely for convenience and are not intended to modify, explain or to be a full or accurate description of the content thereof and shall not in any way affect the meaning or interpretation of this Agreement.

8.28 Construction. The parties have participated jointly in the negotiation and drafting of this Agreement. In the event an ambiguity or question of intent or interpretation arises with respect to this Agreement, this Agreement shall be construed as if drafted jointly by the parties and in accordance with its fair meaning. There shall be no presumption or burden of proof favoring or disfavoring any party by virtue of the authorship of any of the provisions of this Agreement.

8.29 Counterparts. This Agreement may be executed in one or more counterparts, each of which shall be deemed an original. All counterparts shall be construed together and shall constitute one agreement.

8.30 Funding Source Conditions – Contractor’s Obligation. Contractor acknowledges that the City may be paying for the Project by using funds it receives or will receive from various funding sources in the form of grants and/or subsidies, and the like under certain terms and conditions. Contractor acknowledges and agrees that any failure of the Contractor and/or its subcontractors to perform its obligations under the Contract, including, but not limited to, timely submitting accurate reports and records, that in any way results in the City not meeting the terms and conditions placed on the funds by the funding source, or forfeiting its entitlement to or, otherwise, not receiving, the funds, then the Contractor shall be liable to pay the City for the funds not granted to the City on the Project.

8.31 Entire Agreement. This Agreement constitutes the entire agreement between the parties with respect to any matter referenced herein and supersedes any and all other prior writings and oral negotiations. This Agreement may be modified only in writing, and signed by the parties in interest at the time of such modification. The terms of this Agreement shall prevail over any inconsistent provision in any other contract document appurtenant hereto, including exhibits to this Agreement.

City Project No. 1-R-25.

IN WITNESS WHEREOF, the parties have executed and entered into this Agreement as of the date first written above.

CITY OF LA HABRA,
A municipal corporation

Jim Sadro, City Manager

Date: _____

CONTRACTOR

Signature

Date: _____

Name and Title

Social Security or Taxpayer ID Number

ATTEST:

Rhonda J. Barone, City Clerk

Date: _____

APPROVED AS TO FORM:

Keith F. Collins, City Attorney

Date: _____

(Use of City Bond Form is Required)

**LABOR AND MATERIAL PAYMENT BOND
PUBLIC WORK (CALIFORNIA)**

KNOW ALL MEN BY THESE PRESENT:

WHEREAS, _____, as Principal, has entered into a contract dated _____, with the City of La Habra (Obligee) referred to and made a part hereof to perform the following work, to wit: Annual Sidewalk Improvements Project FY24-25 and all appurtenant work in accordance with PROJECT NO. 1-R-25, which requires Principal to file this bond to secure claims made in relation to the project.

NOW THEREFORE, we, _____, as Principal, and _____, a corporation organized under the laws of _____ and duly authorized to transact business in the State of California, as Surety, are held firmly bound unto the City of La Habra, as Obligee, and all sub-contractors, laborers, material persons and other persons employed in the performance of the referenced agreement, in the sum of _____ Dollars (\$ _____ .00), lawful money of the United States of America, for the payment whereof well and truly to be made the Principal and Surety bind themselves, their heirs, executors, administrators, successors, and assigns, jointly and severally, firmly by these presents.

If the above bounden PRINCIPAL, his or its heirs, executors, administrators, successors, assigns, or any of his or its sub-contractors, fails to pay for any materials, provisions, provender, or other supplies, or teams, implements or machinery, used in, upon, for or about the performance of the work contracted to be done, or for any work or labor to persons named in Section 9100 or the Civil Code, thereon of any kind, or for amounts due under the Unemployment Insurance Code with respect to such work or labor deducted, withheld and paid over to the Employment Development Department from the wages of employees of the contractor and sub-contractors pursuant to Section 13020 of the Unemployment Insurance Code, that the SURETY on this bond will pay the same, in an amount not exceeding the sum specified in this bond, AND ALSO, in case suit is brought upon this bond, a reasonable attorney's fee, which shall be awarded by the court to the prevailing party in said suit, said attorney's fee to be taxed as costs in said suit and to be included in the judgment herein rendered.

As part of the obligation secured hereby, the SURETY shall not be exonerated or released from the obligation of the bond by any change, alteration, or modification in or of any contract, plans, specifications, or agreement pertaining or relating to any scheme or work of improvement or pertaining or relating to the furnishing of labor, materials, or equipment therefor, nor by any change or modification of any terms of payment or extension of the time for any payment pertaining or relating to any scheme of work of improvement, nor by any rescission or attempted rescission of the contract, agreement or bond, nor by any conditions precedent or subsequent in the bond attempting to limit the right of recovery of claimants otherwise entitled to recover under

any such contract or agreement, or under the bond, nor, where the bond is given for the benefit of claimants, by any fraud practiced by any person other than the claimant seeking to recover on the bond.

This bond shall inure to the benefit of any and all persons, companies and corporations entitled to file claims under the Civil Code so as to give them a right of action in a suit on this bond.

This bond is executed for the purpose of complying with the laws of the State of California and shall inure to the benefit of any of the persons named in Section 9100 of the Civil Code of the State of California.

IN WITNESS THEREOF, we have hereunto set our hands and seals this _____ day of _____, 20__.

(Corporate Seal)

Principal

By _____

Title _____

(Corporate Seal)

Principal

By _____

Title _____

APPROVED AS TO FORM:
/s/ Keith F. Collins, City Attorney
City Attorney

FAITHFUL PERFORMANCE BOND

KNOW ALL MEN BY THESE PRESENTS:

That we, _____

_____ hereinafter referred to as

“Contractor”, as principal, and _____

_____ as surety, are held and firmly

bound unto City of La Habra in the sum of _____

_____ Lawful money of the United States of America for the payment of which sum well and truly to be made we bind ourselves jointly and severally, firmly by these presents.

The condition of the foregoing obligation is such that WHEREAS, said Contract has been awarded and is about to enter into the annexed contract with City of La Habra for construction of Concrete Improvements as specifically set forth in the documents entitled:

**ANNUAL SIDEWALK IMPROVEMENTS PROJECT FY24-25
CITY PROJECT NO. 1-R-25**

and is required under the terms of the Contract to give this bond in connection with the execution of said contract.

NOW, THEREFORE, if the said Contractor shall well and truly do and perform all of the covenants and obligations of said contract on his part to be done and performed at the times and in the manner specified herein, then this obligation shall be null and void, otherwise it shall be and remain in full force and effect.

PROVIDED, that any alterations in the work to be done or the materials to be furnished which may be made pursuant to the terms of said Contract shall not in any way release either the Contractor or the surety thereunder nor shall any extensions of time granted under the provisions of said Contract release either the Contractor or the surety, and notice of such alterations or extensions of the Contract is hereby waived by the surety.

WITNESS our hands this _____ day of _____, 2025.

Contractor

BY: _____

(Seal)

Title

APPROVED:

Surety

BY: _____

(Seal)

Mailing Address of Surety:

Telephone Number of Surety

(Use of City form is required)

SUPPLEMENTAL INFORMATION TO BE COMPLETED BY PRINCIPAL

If an individual, so state. If a firm or co-partnership, state the firm and give the names of all individual co-partners composing the partnership. If a Corporation, state legal name of corporation; state also the names of the president, secretary, treasurer and manager thereof.

Business Address: _____

Telephone Number: _____

Date: _____

Print Name: _____
Principal

Signature: _____
Title

(Use of City form
is required)

TAX IDENTIFICATION NUMBER

The Tax Equity and Fiscal Responsibility Act of 1982 requires the payer (City of La Habra) to report to the Internal Revenue Service taxable payments to payees.

You (as a payee) are required by law to provide us with your Taxpayer Identification Number (if an individual or partnership, your Social Security Number). If you do not provide us with your correct identification number, you may be subject to a penalty imposed by the Internal Revenue Service. The payments subject to withholdings may include, but are not limited to, interest, dividends, or other payments the City of La Habra made to you. Other payments may include rents, royalties, commissions and fees for service of non-employees.

If you are exempt from income tax, we are still required, by law, to maintain a Tax Identification Number on file. **PLEASE PROVIDE YOUR TAX IDENTIFICATION NUMBER next to the appropriate listing below, sign, date and return to:**

CITY OF LA HABRA FINANCE DEPARTMENT
110 E. La Habra Blvd
La Habra, CA 90631

Exempt: Yes___ No___ Telephone () _____

CORPORATION: _____

U.S.A. OR ANY AGENCIES THEREOF: _____

IRS CODE #501 TAX-EXEMPT ORGANIZATION: _____

A NON-COMMISSIONED CITY OF LA HABRA EMPLOYEE: _____

SOLE PROPRIETOR: _____

A PARTNERSHIP: _____

OTHER: _____(Explain)

Signature/Title: _____ Date: _____

City Project No. 1-R-25.

BID GUARANTEE

**TO THE CITY OF LA HABRA
ANNUAL SIDEWALK IMPROVEMENTS PROJECT FY24-25
PROJECT NO. 1-R-25**

As a material inducement to the City to award the contract for Project No. 4-B-25_to
LESLIE GUNNER CAMPBELL CONSTRUCTION., the undersigned (“Guarantor”) has agreed to
enter into this guarantee. The Guarantor hereby unconditionally guarantees to the fullest extent allowed
by law the following work included in this project: ANNUAL SIDEWALK IMPROVEMENTS
PROJECT FY24-25 (“the work”).

Guarantor guarantees that the materials and equipment used by itself and its subcontractors will be free
from defects and that the work will conform to the plans and specifications. Should any of the materials or
equipment prove defective or should the work as a whole, or any part thereof, prove defective for any reason
whatsoever (except due to intentional torts by the City), or should the work as a whole or any part thereof
fail to operate properly or fail to comply with the plans and specifications, Guarantor will, at the City’s sole
election: 1) reimburse the City, upon written demand, for all of the City’s expenses incurred replacing or
restoring any such equipment or materials, including the cost of any work necessary to make such
replacement or repairs; or 2) replace any such defective material or equipment and repair said work
completely, all without any cost to the City. Guarantor further guarantees that any such repair work will
conform to the plans and specifications for the project. This guarantee will remain in effect for one years
from the date on which the contracted for work is accepted for use by the City.

Guarantor understands and agrees that the City shall have the unqualified option to make any
replacements or repairs itself or to have such replacement, repair, performed by the undersigned. The
City shall have no obligation to consult with Guarantor before the City proceeds to perform any repair,
replacement, or work itself. If the City elects to have Guarantor perform said repair, replacement, or
work, Guarantor agrees that the repair, replacement, or work shall be performed within 15 days after
receipt of a written demand from the City.

If the City elects to perform the replacement, repairs itself, Guarantor agrees to make reimbursement
payment within 15 days after receipt of a written demand for payment from the City.

If the Guarantor fails or refuses to comply with this guarantee, the City shall be entitled to all costs and
expenses, including attorneys and expert fees, reasonably incurred by reason of Guarantor’s failure or
refusal.

Guarantor _____ Date: _____

Contractor: _____ By: _____

Title: _____

STATEMENT OF NON COLLUSION BY CONTRACTOR

The undersigned who submits herewith to the City of La Habra a bid or proposal does hereby certify:

- a. That all statements of fact in such bid or proposal are true;
- b. That such bid or proposal was not made in the interest of or on behalf of any undisclosed person, partnership, company, association, organization or corporation;
- c. That such bid or proposal is genuine and not collusive or sham;
- d. That said bidder has not, directly or indirectly by agreement, communication or conference with anyone, attempted to induce action prejudicial to the interest of the City of La Habra or of any other bidder or anyone else interested in the proposed procurement;
- e. Did not, directly or indirectly, collude, conspire, connive or agree with anyone else that said bidder or anyone else would submit a false or sham bid or proposal, or that anyone should refrain from bidding or withdraw his bid or proposal;
- f. Did not in any manner, directly or indirectly seek by agreement, communication or conference with anyone to raise or fix the bid or proposal price of said bidder or of anyone else, or to raise or fix any overhead, profit or cost element of his bid or proposal price, or that of anyone else;
- g. Did not, directly or indirectly, submit his bid or proposal price or any breakdown thereof, or the contents thereof, or divulge information or data relative thereto, to any corporation, partnership, company, association, organization, bid depository, or to any member agent thereof, or to any individual or group of individuals, except to the City of La Habra, or to any person or persons who have a partnership or their financial interest with said bidder in his business.
- h. Did not provide, directly or indirectly to any officer or employee of the City of La Habra any gratuity, entertainment, meals, or anything of value, whatsoever, which could be objectively construed as intending to invoke any form of reciprocation or favorable treatment.
- i. That no officer or principal of the undersigned firm is related to any officer or employee of the city by blood or marriage within the third degree or is employed, either full or part time, by the City of La Habra either currently or within the last two (2) years.
- j. That no officer or principal of the undersigned firm nor any subcontractor to be engaged by the principal has been convicted by a court of competent jurisdiction of any charge of fraud, bribery, collusion, conspiracy or any other act in violation of any state or federal antitrust law in connection with the bidding upon award of, or performance of, any public work contract, with any public entity, within the last three years.

I certify, under penalty of perjury under the laws of the State of California, that the foregoing is true and correct and that this certification was executed:

On _____ at _____ California.

Firm _____

(Signature)

Street _____

(Print Name & Title)

City _____ State _____ Zip _____

CERTIFICATION OF COMPLIANCE

AFFIRMATIVE ACTION REQUIREMENTS

EQUAL EMPLOYMENT OPPORTUNITY

For

**ANNUAL SIDEWALK IMPROVEMENT PROJECT FY 24-25
CITY PROJECT NO. 1-R-25**

_____ Certifies that:

(Contractor)

It has adopted and approved affirmative action plan in compliance with Title VII of the Civil Rights Act and the Equal Employment Opportunity Act of 1972 and agrees to submit a copy of that plan to the Assistant to the City Manager/Personnel of the City of La Habra for inspection prior to the award of contract.

Signed: _____

By: _____

Title: _____

Date: _____

EXHIBIT A
SCOPE OF SERVICES

SECTION D

PROPOSAL

PROPOSAL

City of La Habra
Civic Center
110 E. La Habra Blvd.
La Habra, California 90631

Gentlemen:

The undersigned hereby proposes to perform all work for which a contract may be awarded him and to furnish any and all plant, labor, services, materials, tools, equipment, supplies, transportation, utilities, and all other items and facilities necessary therefor as provided in the Contract Documents, and to do everything required therein for the project specifically set forth in documents entitled:

**ANNUAL SIDEWALK IMPROVEMENTS PROJECT
FY 24-25, PROJECT NO. 1-R-25**

together with appurtenances thereto, all as set forth on the drawing and in the specifications and other Contract Documents; and, he further proposes and agrees that if this Proposal is accepted he will contract in the form and manner stipulated to perform all the work called for by drawings, specifications and other Contract Documents and to complete all such work in strict conformity therewith within the time limits set forth therein, and that he will accept as full payment therefor the prices set forth in the Bid Schedule forming a part hereof.

A *(Cashier's Check) *(Certified Check) *(Bid Bond) properly made payable to City of La Habra hereinafter designated as the Owner for the sum of thirteen thousand five hundred and six and five dollars (\$ 13,555.00), which amount is not less than ten percent (10%) of the total amount of this bid, is attached hereto and is given as a guarantee that the undersigned will execute the Agreement and furnish the required bonds if awarded the Contract; and, in case of failure to do so within the time provided the proceeds of said check shall be forfeited to the *Owner/Sureties Liability to the Owner for forfeiture of the face amount of the Bond shall be considered as established.

(*) Delete inapplicable word or phrase.

It is understood and agreed that:

1. The undersigned has carefully examined all the Contract Documents which will form a part of the Contract;
2. The undersigned has, by investigation of the site of the work and otherwise, satisfied himself as to the nature and location of the work and has fully informed himself as to all conditions and matters which can in any way affect the work or the cost thereof;
3. The undersigned fully understands the scope of the work and has checked carefully all words and figures inserted in this proposal and he further understands that the Owner will in no way be responsible for any errors or omissions in the preparation of this proposal;

4. The undersigned will execute the Agreement and furnish the required Performance and Payment Bonds and proof of insurance coverage, within ten (10) days (not including Saturdays, Sundays and holidays) after notice to him of acceptance of his bid by the Owner; and further, that this bid may not be withdrawn for a period of sixty (60) days after the date set for the opening thereof, unless otherwise required by law. If any bidder shall withdraw his bid within said period, the Contractor shall be liable under the provisions of the Bid Security or the Contract and his surety shall be liable under the Bid Bond, as the case may be;
5. The undersigned hereby certifies that this proposal is genuine and not sham or collusive or made in the interest or in behalf of any person not herein named and the undersigned has not directly or indirectly induced or solicited any other bidder to put in a sham bid or any other person, firm or corporation to refrain from bidding; the undersigned has not in any manner sought by collusion to secure for himself an advantage over any other bidder;
6. In conformance with current statutory requirements of Section 1860, et seq., of the Labor Code of the State of California, the undersigned confirms the following as his certification:

I am aware of the provisions of Section 3700 of the Labor Code which requires every employer to be insured against liability of worker's compensation or to undertake self insurance in accordance with the provisions before commencing the performance of the work of this contract.

NOW, in compliance with the Notice Inviting Bids and all the provisions hereinbefore stipulated, the undersigned, with full cognizance thereof, hereby proposes to perform the entire work for the prices set forth in the attached Bid Schedule upon which award of the Contract is made.

Date: 9/29, 2025

Bidder Leslie Gumar Campbell Construction

By Les Campbell

Title Owner

Bidder's Post Office Address:
22313 San Joaquin DR W
CANYON LAKE CA 92587

Corporation organized under
the laws of the State of

Names and addresses of all owners
of the firm or names and titles of
all officers of the corporation:

Leslie Geneva Campbell

(corporate seal)

BIDDER'S INFORMATION

Contractor's License No. 954172 Expiration Date 12/31/2026

Classification of Contractor's License No. A, B, C10

Contractor Leslie Gunner Campbell Construction
(name of firm)

By  Curren
(signature) (title)

Business Address: 22313 SAN JOAQUIN DR. West
CANYON LAKE CA 92587

Phone (760) 905-0043

I/We certify that the information provided above is complete and true to the best of my/our knowledge.

 9/28/25
Contractor Date

Contractor's DIR Public Works Registration No. 2 00000 3460

BID SCHEDULE

**ANNUAL SIDEWALK IMPROVEMENTS PROJECT FY24-25
PROJECT NO. 1-R-25**

ITEM	DESCRIPTION	QUANTITY	UNIT	UNIT PRICE	AMOUNT
1	MOBILIZATION (Not to exceed Five Percent (5%) of the total bid amount)	1	LS	1000 ^{cc}	1,000 ^{cc}
2	STORM WATER BEST MANAGEMENT PRACTICES (BMPs)	1	LS	2000 ^{cc}	2,000 ^{cc}
3	TRAFFIC CONTROL, SAFETY, AND CLEANUP (Not to exceed Five Percent (5%) of the total bid amount)	1	LS	2000 ^{cc}	2,000 ^{cc}
4	REMOVE AND RECONSTRUCT 4" THICK CONCRETE SIDEWALK PER SPPWC DETAIL 112-2	7,000	SF	9 ^{cc}	63,000 ^{cc}
5	REMOVE AND RECONSTRUCT 6" THICK CONCRETE DRIVEWAY APPROACH PER SPPWC DETAIL 110-2 WITH 1 FT. WIDTH AC SLOT	750	SF	16 ^{cc}	12,000 ^{cc}
6	REMOVE AND RECONSTRUCT VARIABLE HEIGHT CONCRETE CURB & GUTTER OVER 6" CMB PER SPPWC DETAIL 120-3 WITH 1 FT. WIDTH AC SLOT	250	LF	85 ^{cc}	21,250 ^{cc}
7	REMOVE STREET TREE (12 IN. TO 24 IN. DIAMATER)	11	EA	1,000 ^{cc}	11,000 ^{cc}
8	PLANT 24" BOX STREET TREE AND STAKE, AND INSTALL ROOT BARRIERS PER SPPWC DETAIL 518-4 AND 520-5	11	EA	1,300 ^{cc}	14,300 ^{cc}
9	REMOVE AND RECONSTRUCT CONCRETE WALKWAY WITH DETECTABLE WARNING SURFACE AND 1 FT. AC SLOT	200	SF	45	9,000 ^{cc}

Continued on next page

TOTAL BID PRICE FOR BID SCHEDULE IN WORDS: One hundred
thirty five thousand five hundred & fifty dollars and $\frac{00}{100}$

Note: All bid quantities are estimated and for bidding purposes only, it may be increased or decreased at the discretion of the CITY. The provisions of Sections 7-3.5.2 and 7-3.5.3 of the Greenbook governing increases or decreases in quantity of more than 25% shall not apply.

Note: The TOTAL BID PRICE shall be used as the basis of bid in determining the low bid for this project.

Leslie Gunna Campbell Construction
CONTRACTOR

Leslie Gunna Campbell
BY

Owner
TITLE

9/30/25
DATE

ACKNOWLEDGEMENT OF ADDENDA RECEIVED

The Bidder shall acknowledge the receipt of addenda by placing an "X" by each addendum received.

Addendum No. 1 X
Addendum No. 2
Addendum No. 3
Addendum No. 4
Addendum No. 5
Addendum No. 6
Addendum No. 7
Addendum No. 8

If an addendum or addenda have been issued by the CITY and is not noted above as being received by the Bidder, the Bid Proposal may be rejected.



September 22, 2025

ADDENDUM NO. 1
ANNUAL SIDEWALK IMPROVEMENTS PROJECT FY24-25
CITY PROJECT NO. 1-R-25

To all prospective bidders and plan holders for **ANNUAL SIDEWALK IMPROVEMENTS PROJECT FY24-25 CITY PROJECT NO. 1-R-25.**

The intent of this Addendum No. 1 is to make revisions, additions and/or deletions, and answer and/or clarify questions for the Annual Sidewalk Improvements Project FY24-25, City Project No. 1-R-25; and are therefore hereby made a part of the contract bid documents.

A. Questions and Answers:

1) Reference: Is there a DBE goal amount?

Response: City does not have a specific DBE goals however it does strongly encourage the utilization of DBE subcontractors/vendors, etc.

2) Does this project have PLA?

Response: No.

An acknowledgment of receipt of this Addendum No. 1 shall be submitted with the Bid Proposal. Failure to provide such acknowledgment shall render the bid as non-responsive and subject to rejection.

Date: September 22, 2025

BY ORDER OF THE CITY OF LA HABRA

BY:

Albert Mendoza, P.E.
Deputy Director of Public Works /
City Engineer

Contractor (Signature)

Name

Date

If Contractor has not performed work for the City of La Habra within the last five (5) years, list all work done within said five years (attach additional sheets if necessary). Note if work was done as subcontractor (include only subcontract amount):

Work Description & Contract Amount	Agency	Date Completed
See attached		

Contractor's License No.: 954172 Class: A, B, C10

a. Date first obtained: Nov 2010 Expiration: 12/31/26

b. Has License ever been suspended or revoked? NO
 If yes, described when and why: _____

c. Any current claims against License or Bond? NO
 If yes, describe claims: _____

Principals in Company (List all – attach additional sheets if necessary):

<u>NAME</u>	<u>TITLE</u>	<u>LICENSE NO.</u> (If Applicable)
<u>Les Campbell</u>	<u>owner</u>	<u>954172</u>
_____	_____	_____
_____	_____	_____

City of La Habra
ANNUAL SIDEWALK IMPROVEMENT PROJECT FY24-25
City Project No. 1-R-25

Relevant Work Experience – LGC Construction

I bring over 30 years of construction expertise across public works, civil, healthcare, and security sectors. My career began in the U.S. Navy as a Seabee with the Civil Engineering and Construction Battalion, where I trained as a Civil Engineer, Carpenter, and Construction Electrician. Following my service, I advanced as a Journeyman Carpenter through Local 630 Union Hall in Long Beach and later served as a Project Superintendent and Project Manager on large-scale union and public works projects.

Over the years, I have delivered projects ranging from \$10,000 to over \$25 million in value. My experience includes:

- **Civil/Public Works:** sidewalks, curbs and gutters, ADA ramps and entrances, landscaping planters, and heavy civil projects.
- **Healthcare Construction (OSHDP/DSA):** hospitals, medical office buildings, tenant improvements, and specialized compliance projects.
- **Security/Defense Construction:** SCIFs, SAPFs, and secure facilities under Army Corps of Engineers and Department of Defense oversight.
- **Commercial & Infrastructure:** high-rises, parking structures, bridges, electrical upgrades, and site development.

I hold A, B, and C-10 contractor licenses in California and certifications in Construction Quality Control (2024), OSHA-30 (2016, 2022), and DoD SCIF/SAPF regulations. With a track record managing union crews and multi-site programs under stringent compliance, I bring the leadership experience earned on multi-million-dollar projects to deliver this work confidently.

Representative Projects

- **City of Temecula – Park Renovation and ADA Improvement - April 2025 - Aug 2025**
Contract Value: \$170,000 | *Completed:* August 2025
Reference: Jay Oldham, City Inspector – (951) 491-5620
 - Work performed - ADA concrete , electrical , steel stud framing , drywall , stucco , structural steel , plumbing , windows , concrete demo

- **City of Corona – Fundamental ADA Improvements**
Contract Value: \$2.3 million | *Role:* Site Superintendent for GC (Newman Midland Corp)
References:
 - Giovanni Miliaki, DSA Inspector – (714) 306-3387

 - Adam Nasary, Owner – NMC – (562) 254-1901
 - Work performed - ADA concrete , electrical , steel stud framing , drywall , stucco , structural steel , plumbing , windows , concrete demo

- **Army Corps of Engineers / Federal Security Facilities**
Scope: SCIFs, OSHPD facilities, public works, and union-scale infrastructure projects valued \$10,000 to \$25 million.
Roles: Project Manager, Site Superintendent, QC Manager
References:
 - Christina Ramariz – (530) 933-7991

 - Brandon Rivers – (406) 480-3605
 - Public Works (side walks , Bridges , Site work , Street lights , grading
 - Large Union Work (Parking Structures , High Rises , Bridges , Hospital OSHPD
 - Army Corp of Engineers — Civil Construction (Highways , Under Ground Utilities , SCIFs)
 - Naval Construction Battalion – Civil Work (Surveying , Parking Lots , RCP / UNder Ground Utilities , Pole Lighting units , CMU ,)

DBE BIDDER'S LIST

All bidders/proposers are requested to provide the following information for all DBE and non-DBE contractors or consultants who provided a proposal, bid, quote, or were contacted by the proposed prime. This information is also requested from the proposed prime contractor/consultant and should be submitted with their bid/proposal. The City of La Habra will use this information to maintain and update a "Bidders" List to assist in the overall annual DBE goal-setting process.

Firm Name: <u>LGC CONSTRUCTION</u>	Phone: <u>761-905-0043</u>
Address: <u>22313 SAN JOAQUIN BLVD. WEST CANYON LAKE CA 92507</u>	Fax: _____
Contact Person: <u>April Campbell</u>	No. of years in business: <u>15</u>
Is the firm currently certified as a DBE under 49 CFR Part 26: YES: <input checked="" type="checkbox"/> NO: <input type="checkbox"/>	
Type of work/services/materials provided by firm? <u>A, B, AND C10</u>	
<u>Contracting</u>	
<hr/> What was your firm's Gross Annual receipts for last year?	
<u>Less than \$1 Million</u>	
Less than \$5 Million	
Less than \$10 Million	
Less than \$15 Million	
More than \$15 Million	

This form can be duplicated if necessary to report all bidders (DBEs and non-DBEs) information.

REFERENCES

[Work similar in scope magnitude and degree of difficulty completed by Contractor within the past three (3) years.]

1. Name (Firm/Agency): City of Temecula
Address: 4100 Main Street Temecula CA
Contact Person: Jay Oldham Telephone No. 951-491-5600
Title of Project: Park Renovations Expansion and ADA Improvements
Project Location: 30875 Rancho Vista Road Temecula CA
Date of Completion: Aug 2025 Contract Amount: \$ 170K
2. Name (Firm/Agency): New MAN Mid Land Corp
Address: 1355 Redondo Ave #12 Long Beach CA
Contact Person: Adam Nasay Telephone No. 562-254-1901
Title of Project: Corona Fundamental ADA Upgrade
Project Location: 1230 S. Main Corona CA
Date of Completion: March 2025 Contract Amount: \$ 2.3 million
3. Name (Firm/Agency): ASI
Address: 4061 Seaport Blvd West Sacramento CA
Contact Person: Kendall Sokolowski Telephone No. 909-714-7701
Title of Project: Brea Bank of America CA
Project Location: 290 S State College Blvd Brea 92821
Date of Completion: Sept 2023 Contract Amount: \$ 300K
4. Name (Firm/Agency): Whitney Turner
Address: 3911 Sorrento Valley Blvd San Diego CA
Contact Person: Brandon Reeves Telephone No. 408-480-3805
Title of Project: Kaiser Zion / Kaiser Riverside
Project Location: 4647 Zion Ave San Diego / 10800 Magdalen Ave Riverside
Date of Completion: July 2023 Contract Amount: \$ 25 million

VIOLATIONS OF FEDERAL, STATE, OR LOCAL LAWS

1. Has your firm or its officers been assessed any penalties by an agency for noncompliance or violations of Federal, State, or Local labor laws and/or business or licensing regulations within the past five (5) years relating to your construction projects?

Yes/No: Federal/State:

If "yes", identify and describe, (including agency and status):

Have the penalties been paid? Yes/No: N/A

2. Does your firm or its officers have any ongoing investigations by any public agency regarding violations of the State Labor Code, California Business and Professions Code or State Licensing Laws?

Yes/No: Code/Laws: Section/Article:

If "yes", identify and describe, (including agency and status):

DISQUALIFICATION OR DEBARMENT

Has your firm, any officer of your firm, or any employee who has a proprietary interest in your firm ever been disqualified, removed, or otherwise prevented from bidding on, performing work on, or completing a federal, state, or local project because of a violation of law or a safety regulation?

Yes/No: NO

If yes, provide the following information (if more than once, use separate sheets):

Date: _____ Entity: _____

Location: _____

Reason: _____

Provide Status and any Supplemental Statement: _____

Has your firm been reinstated by this entity?

Yes/No: N/A

LIST OF SUBCONTRACTORS

**ANNUAL SIDEWALK IMPROVEMENTS PROJECT FY24-25
PROJECT NO.1-R-25**

The bidder shall list below the name and the location of the place of business of each Subcontractor who will perform work or render services to the prime contractor in or about the construction of the work or improvement in excess of one-half of one percent (1/2%) of the prime contractor's total bid or ten thousand dollars (\$10,000.00) whichever is greater in accordance with the requirements of Section 4100 to 4133 inclusive of the public contracts code.

<u>Work to be Performed</u>	<u>License Number</u>	<u>Subcontractor and Address of Office, Mill or Shops</u>	<u>Percent of Total Contract</u>	<u>DBE YES</u>
NO				
LGC Construction 954172 will be performing all the work in house, we have a DBE certification see attached				

Note: Do not list alternative subcontractors for the same work.

Contractor Leslie Gummer Campbell Construction 

*I will be using my Bonding Company
OPPOSED TO A CHECK*

BID SECURITY FORM

(Check to Accompany Bid)

(Note: The following form shall be used in case check accompanies bid.)

Accompanying this proposal is a *(Certified) *(Cashiers) check payable to the order of the City of La Habra, California, hereinafter referred to as "Owner", for

**ANNUAL SIDEWALK IMPROVEMENT PROJECT FY24-25
PROJECT NO. 1-R-25**

In the amount of \$ _____ Dollars,
this amount being ten percent (10%) of the total amount of the bid. The proceeds of this check shall become the property of said Owner provided this proposal shall be accepted by the said Owner through action if its legally constituted contracting authorities and the undersigned shall fail to execute a contract and furnish the required Performance and Payment Bonds and proof of insurance coverage within the stipulated time; otherwise, the check shall be returned to the undersigned. The proceeds of this check shall also become the property of the Owner if the undersigned shall withdraw his bid within the period of forty-five (45) days after the date set for the opening thereof unless otherwise required by law and notwithstanding the award of the Contract to another bidder.

Bidder

*Delete the inapplicable word.

NOTE: If the bidder desires to use a bond instead of a check, the Bid Bond form on the following pages shall be executed. The sum of this bond shall be not less than ten percent (10%) of the total amount of the bid.

BID BOND

KNOW ALL MEN BY THESE PRESENTS:

That we LESLIE GUNNER CAMPBELL CONSTRUCTION as principal and Travelers Casualty and Surety Company of America as surety, are held and firmly bound unto the City of La Habra, California hereinafter referred to as "Owner", in the sum of 10% of Bid Amount Dollars (\$) to be paid to the said Owner, its successors and assigns for which payment well and truly to be made we bind ourselves, our heirs, executors, administrators, successors and assigns, jointly and severally, firmly by these presents.

THE CONDITION OF THIS OBLIGATION IS SUCH that if the certain proposal of the above bounden for the construction of Street Improvements as specifically set forth in documents entitled:

**ANNUAL SIDEWALK IMPROVEMENTS PROJECT FY24-25
CITY PROJECT NO. 1-R-25**

all in accordance with the specifications and drawings on file at the offices of the City Clerk of the City of La Habra, California and is not withdrawn within the period of sixty (60) days after the date set for the opening of bids unless otherwise required by law and notwithstanding the award of the Contract to another bidder and that if said proposal is accepted by the Owner through action of its legally constituted contracting authorities and if the above bounden his heirs, executors, administrators, successors and assigns shall duly enter into and execute a contract for such construction and shall execute and deliver the required Performance and Payment Bonds and proof of insurance coverage within ten (10) days (not including Saturdays, Sundays and Holidays) after the date of notification by and from the said Owner that the said contract is ready for execution, then this obligation shall become null and void; otherwise, it shall be and remain in full force and virtue.

IN WITNESS WHEREOF, we hereunto set hands and seal this 23rd

day of September, 2025.



[Signature]
SURETY- Travelers Casualty and Surety Company of America

[Signature]
BIDDER

NOTE: The standard printed bond form of any bonding company acceptable to the Owner may be used in lieu of the foregoing approved sample bond form provided the security stipulations protecting the Owner are not in any way reduced by use of the Surety Company's printed standard form.



Travelers Casualty and Surety Company of America
Travelers Casualty and Surety Company
St. Paul Fire and Marine Insurance Company

POWER OF ATTORNEY

Travelers Casualty and Surety Company of America, Travelers Casualty and Surety Company, and St. Paul Fire and Marine Insurance Company are corporations duly organized under the laws of the State of Connecticut (herein collectively called the "Companies"), and the Companies do hereby make, constitute and appoint **KEVIN P HARVEY** of **TENMILE**, **Oregon**, their true and lawful Attorney(s)-in-Fact to sign, execute, seal and acknowledge any and all bonds, recognizances, conditional undertakings and other writings obligatory in the nature thereof on behalf of the Companies in their business of guaranteeing the fidelity of persons, guaranteeing the performance of contracts and executing or guaranteeing bonds and undertakings required or permitted in any actions or proceedings allowed by law.

IN WITNESS WHEREOF, the Companies have caused this instrument to be signed, and their corporate seals to be hereto affixed, this 16th day of February, 2024.



State of Connecticut

By: 
 Bryce Grissom, Senior Vice President

City of Hartford ss.

On this the 16th day of February, 2024, before me personally appeared Bryce Grissom, who acknowledged himself to be the Senior Vice President of each of the Companies, and that he, as such, being authorized so to do, executed the foregoing instrument for the purposes therein contained by signing on behalf of said Companies by himself as a duly authorized officer.

IN WITNESS WHEREOF, I hereunto set my hand and official seal.

My Commission expires the 30th day of June, 2026



 Anna P. Nowik, Notary Public

This Power of Attorney is granted under and by the authority of the following resolutions adopted by the Boards of Directors of each of the Companies, which resolutions are now in full force and effect, reading as follows:

RESOLVED, that the Chairman, the President, any Vice Chairman, any Executive Vice President, any Senior Vice President, any Vice President, any Second Vice President, the Treasurer, any Assistant Treasurer, the Corporate Secretary or any Assistant Secretary may appoint Attorneys-in-Fact and Agents to act for and on behalf of the Company and may give such appointee such authority as his or her certificate of authority may prescribe to sign with the Company's name and seal with the Company's seal bonds, recognizances, contracts of indemnity, and other writings obligatory in the nature of a bond, recognizance, or conditional undertaking, and any of said officers or the Board of Directors at any time may remove any such appointee and revoke the power given him or her; and it is

FURTHER RESOLVED, that the Chairman, the President, any Vice Chairman, any Executive Vice President, any Senior Vice President or any Vice President may delegate all or any part of the foregoing authority to one or more officers or employees of this Company, provided that each such delegation is in writing and a copy thereof is filed in the office of the Secretary; and it is

FURTHER RESOLVED, that any bond, recognizance, contract of indemnity, or writing obligatory in the nature of a bond, recognizance, or conditional undertaking shall be valid and binding upon the Company when (a) signed by the President, any Vice Chairman, any Executive Vice President, any Senior Vice President or any Vice President, any Assistant Vice President, any Secretary, any Assistant Secretary, the Treasurer, any Assistant Treasurer, the Corporate Secretary or any Assistant Secretary and duly attested and sealed with the Company's seal by a Secretary or Assistant Secretary; or (b) duly executed (under seal, if required) by one or more Attorneys-in-Fact and Agents pursuant to the power prescribed in his or her certificate or their certificates of authority or by one or more Company officers pursuant to a written delegation of authority; and it is

FURTHER RESOLVED, that the signature of each of the following officers: President, any Executive Vice President, any Senior Vice President, any Vice President, any Assistant Vice President, any Secretary, any Assistant Secretary, and the seal of the Company may be affixed by facsimile to any Power of Attorney or to any certificate relating thereto appointing Resident Vice Presidents, Resident Assistant Secretaries or Attorneys-in-Fact for purposes only of executing and attesting bonds and undertakings and other writings obligatory in the nature thereof, and any such Power of Attorney or certificate bearing such facsimile signature or facsimile seal shall be valid and binding upon the Company and any such power so executed and certified by such facsimile signature and facsimile seal shall be valid and binding on the Company in the future with respect to any bond or understanding to which it is attached.

I, **Kevin E. Hughes**, the undersigned, Assistant Secretary of each of the Companies, do hereby certify that the above and foregoing is a true and correct copy of the Power of Attorney executed by said Companies, which remains in full force and effect.

Dated this 24th day of September, 2025



 Kevin E. Hughes, Assistant Secretary

To verify the authenticity of this Power of Attorney, please call us at 1-800-421-3880.
 Please refer to the above-named Attorney(s)-in-Fact and the details of the bond to which this Power of Attorney is attached.

ACKNOWLEDGMENT

A notary public or other officer completing this certificate verifies only the identity of the individual who signed the document to which this certificate is attached, and not the truthfulness, accuracy, or validity of that document.

State of Wyoming
County of Albany)

On Sep 24th 2025 before me, G.L. Harvey
(insert name and title of the officer)

personally appeared Kevin Harvey
who proved to me on the basis of satisfactory evidence to be the person(s) whose name(s) is/are subscribed to the within instrument and acknowledged to me that he/she/they executed the same in his/her/their authorized capacity(ies), and that by his/her/their signature(s) on the instrument the person(s), or the entity upon behalf of which the person(s) acted, executed the instrument.

WITNESS my hand and official seal.

Signature  (Seal)

G.L. HARVEY
Notary Public - State of Wyoming
Commission ID: 171446
My Commission Expires July 17, 2031

NON-COLLUSION AFFIDAVIT
FOR

ANNUAL SIDEWALK IMPROVEMENTS PROJECT FY24-25
PROJECT NO. 1-R-25

(TO BE EXECUTED BY EACH AWARDEE OF A PRINCIPAL CONTRACT)

STATE OF CALIFORNIA)
) SS.
)

Leslie G Campbell, being first duly sworn,
deposes and says that he is Owner
(sole owner, partner, president, secretary, etc.)

of Leslie G. Campbell Construction

The party making the foregoing bid; that such bid is not made in the interest of or on behalf of any undisclosed person, partnership, company, association, organization or corporation; that such bid is genuine and not collusive or sham; that said bidder has not directly or indirectly induced or solicited any other bidder to put in a false or sham bid, and has not directly or indirectly colluded, conspired, connived, or agreed with any bidder or anyone else to put in a sham bid, nor that anyone shall refrain from bidding; that said bidder has not in any manner directly or indirectly sought by agreement, communication or conference with anyone to fix the bid price of said bidder or of any other bidder, nor to fix any overhead, profit cost element of such bid price nor of that of any other bidder nor to secure any advantage against the public body awarding the contract or anyone interested in the proposed contract; that all statements contained in such bid are true; and, further, that said bidder has not directly or indirectly, submitted his bid price or any breakdown thereof, nor the contents thereof, nor divulged information or data relative thereto, nor paid and will not pay any fee in connection therewith to any corporation, partnership, company, association, organization, bid depository, nor to any member of agent thereof nor to any other individual except to such person or persons as have a partnership or other financial interest with said bidder in his general business.

Signed: [Signature]
Title: Owner

Subscribed and sworn to before me

This 29 day of Sept, 2025

SEAL OF NOTARY PUBLIC

Please See Notary
Attachment AA

CALIFORNIA JURAT CERTIFICATE

A Notary Public or other officer completing this certificate verifies only the identity of the individual who signed the document to which this certificate is attached, and not the truthfulness, accuracy, or validity of that document.

State of California

County of Riverside

Subscribed and sworn to (or affirmed) before me on this 29 day of September
2025, by Leslie G. Campbell

proved to me on the basis of satisfactory evidence to be the person who appeared before me.

WITNESS MY HAND AND OFFICIAL SEAL.

Signature of Notary Public

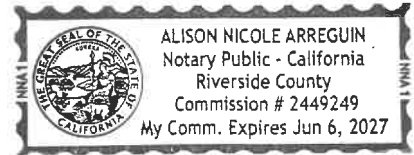

(Notary Seal)

OPTIONAL INFORMATION

The jurat contained within this document is in accordance with California law. Any affidavit subscribed and sworn to before a notary shall use the preceding wording or substantially similar wording pursuant to Civil Code sections 1189 and 8202. A jurat certificate cannot be affixed to a document sent by mail or otherwise delivered to a notary public, including electronic means, whereby the signer did not personally appear before the notary public, even if the signer is known by the notary public. The seal and signature cannot be affixed to a document without the correct notarial wording. As an additional option an affiant can produce an affidavit on the same document as the notarial certificate wording to eliminate the use of additional documentation.

DESCRIPTION OF ATTACHED DOCUMENT

Non-Collusion Affidavit
(Title of document)

Number of Pages 1 (Including jurat)

Document Date 9/29/25

(Additional Information)

CAPACITY CLAIMED BY THE SIGNER

- Individual
 Corporate Officer
 Partner
 Attorney-In-Fact
 Trustee
 Other: _____

WORKER'S COMPENSATION CERTIFICATE

(AS REQUIRED BY SECTION 1861
OF THE CALIFORNIA LABOR CODE)

I am aware of the provisions of Section 3700 of the California Labor Code, which require every employer to be insured against liability for worker's compensation, or to undertake self-insurance in accordance with the provisions of said Code, and I will comply with such provisions before commencing the performance of the Work of this Contract.

Contractor Leslie Gunn Campbell Construction
By Les Campbell
Title Owner

Public Contract Code Section 10285.1 Statement

In conformance with Public Contract Code Section 10285.1 (Chapter 376, Stats. 1985), the bidder hereby declares under penalty of perjury under the laws of the State of California that the bidder **has** ____, **has not** been convicted within the preceding three years of any offenses referred to in that section, including any charge of fraud, bribery, collusion, conspiracy, or any other act in violation of any state or Federal antitrust law in connection with the bidding upon, award of, or performance of, any public works contract, as defined in Public Contract Code Section 1101, with any public entity, as defined in Public Contract Code Section 1100, including the Regents of the University of California or the Trustees of the California State University. The term "bidder" is understood to include any partner, member, officer, director, responsible managing officer, or responsible managing employee thereof, as referred to in Section 10285.1.

Note: The bidder must place a check mark after "has" or "has not" in one of the blank spaces provided. The above Statement is part of the Proposal. Signing this Proposal on the signature portion thereof shall also constitute signature of this Statement. Bidders are cautioned that making a false certification may subject the certifier to criminal prosecution.

Public Contract Code Section 10162 Questionnaire

In conformance with Public Contract Code Section 10162, the Bidder shall complete, under penalty of perjury, the following questionnaire:

Has the bidder, any officer of the bidder, or any employee of the bidder who has a proprietary interest in the bidder, ever been disqualified, removed, or otherwise prevented from bidding on, or completing a federal, state, or local government project because of a violation of law or a safety regulation?

Yes _____ No

If the answer is yes, explain the circumstances in the following space.

Public Contract Code Section 10232 Statement

In conformance with Public Contract Code Section 10232, the Contractor, hereby states under penalty of perjury, that no more than one final unappealable finding of contempt of court by a federal court has been issued against the Contractor within the immediately preceding two year period because of the Contractor's failure to comply with an order of a federal court which orders the Contractor to comply with an order of the National Labor Relations Board.

Note: The above Statement and Questionnaire are part of the Proposal. Signing this Proposal on the signature portion thereof shall also constitute signature of this Statement and Questionnaire.

Bidders are cautioned that making a false certification may subject the certifier to criminal prosecution.



Metro

Los Angeles County
Metropolitan Transportation Authority

One Gateway Plaza
Los Angeles, CA 90012-2952

213.922.2000 Tel
metro.net

February 20, 2024

Metro File #9711

Mrs. April Campbell
LGC Construction DBA Leslie Gunner Campbell Construction
22313 San Joaquin Drive W
Canyon Lake, CA 92587

Subject: Small Business Enterprise Certification

Dear Mrs. April Campbell:

We are pleased to advise you that after careful review of your application and supporting documentation, the Los Angeles County Metropolitan Transportation Authority (Metro) has determined that your firm meets the eligibility standards to be certified as a Small Business Enterprise (SBE) as required under Metro's SBE Program. Your firm will be listed in Metro's SBE database of certified SBEs under the following specific areas of expertise:

NAICS 238210: ELECTRICAL CONTRACTORS AND OTHER WIRING INSTALLATION CONTRACTORS
NAICS 561621: SECURITY SYSTEMS SERVICES (EXCEPT LOCKSMITHS)

Your SBE certification is valid for five years from the date of this letter and applies only for the above NAICS code(s). Any additions and revisions must be submitted to Metro for review and approval.

In order to ensure your continuing SBE status, you are required to submit an annual update along with supporting documentation. If no changes are noted, then your SBE status remains current. If there are changes, Metro will review to determine continued SBE eligibility. Please note, your SBE status remains in effect unless Metro notifies you otherwise.

After the five-year certification period, your entire file will be reviewed in order to ascertain continued SBE certification status. You will be notified of the pending SBE status review and any documentation updates necessary prior to the expiration date.

Also, should any changes occur that could affect your certification status prior to receipt of the annual update application, such as changes in your firm's name, business/ mailing address, ownership, management or control, or failure to meet the applicable business size standards or personal net worth standard, please notify Metro immediately.

Metro reserves the right to withdraw this certification if at any time it is determined that it was knowingly obtained by false, misleading, or incorrect information. Your SBE certification is subject to review at any time. The firm thereby consents to the examination of its books, records, and documents by Metro.

Congratulations, and thank you for your interest in Metro's SBE Program. Should you have any questions, please contact us at (213) 922-2600. For information on Metro contracting opportunities, please visit our website at www.metro.net/connect.

Sincerely,

Ramon Ortiz
Director, Certification & Economic Development



Metro

Los Angeles County
Metropolitan Transportation Authority

One Gateway Plaza
Los Angeles, CA 90012-2952

213.922.2000 Tel
metro.net



CALIFORNIA UNIFIED CERTIFICATION PROGRAM

February 20, 2024

CUCP# 52022
Metro File #9711

Mrs. April Campbell
LGC Construction DBA Leslie Gunner Campbell Construction
22313 San Joaquin Drive W
Canyon Lake, CA 92587

Subject: Disadvantaged Business Enterprise Certification

Dear Mrs. April Campbell:

We are pleased to advise you that after careful review of your application and supporting documentation, the Los Angeles County Metropolitan Transportation Authority (Metro) has determined that your firm meets the eligibility standards to be certified as a Disadvantaged Business Enterprise (DBE) as required under the U.S. Department of Transportation (U.S. DOT) Regulation 49 CFR Part 26, as amended. This certification will be recognized by all of the U.S. DOT recipients in California. Your firm will be listed in the California Unified Certification Program (CUCP) database of certified DBEs under the following specific area(s) of expertise that you have identified on the NAICS codes form of the application package:

NAICS 238210: ELECTRICAL CONTRACTORS AND OTHER WIRING INSTALLATION CONTRACTORS
NAICS 561621: SECURITY SYSTEMS SERVICES (EXCEPT LOCKSMITHS)

Your DBE certification applies only for the above code(s). You may review your firm's information in the CUCP DBE database which can be accessed at the CUCP website at <https://californiaucp.dbesystem.com>. Any additions and revisions must be submitted to Metro for review and approval.

In order to ensure your continuing DBE status, you are required to submit an annual update along with supporting documentation. If no changes are noted, then your DBE status remains current. If there are changes, Metro will review to determine continued DBE eligibility. Please note, your DBE status remains in effect unless Metro notifies you otherwise.

Also, should any changes occur that could affect your certification status prior to receipt of the annual update, such as changes in your firm's name, business/ mailing address, ownership, management or control, or failure to meet the applicable business size standards or personal net worth standard, please notify Metro immediately. Failure to submit forms and/or change of information will be deemed a failure to cooperate under Section 26.109 of the Regulations.

Metro reserves the right to withdraw this certification if at any time it is determined that it was knowingly obtained by false, misleading, or incorrect information. Your DBE certification is subject to review at any time. The firm thereby consents to the examination of its books, records and documents by Metro.

Congratulations, and thank you for your interest in the DBE program. Should you have any questions, please contact us at (213) 922-2600. For information on Metro contracting opportunities, please visit our website at www.metro.net/connect.

Sincerely,

**CITY OF LA HABRA
PUBLIC WORKS DEPARTMENT
ENGINEERING DIVISION**



110 E. LA HABRA BOULEVARD
LA HABRA, CA 90631
(562) 383-4151

**SPECIFICATIONS FOR
ANNUAL SIDEWALK IMPROVEMENTS PROJECT
FY24-25 - CITY PROJECT NO. 1-R-25**

CITY MANAGER JIM SADRO

LA HABRA CITY COUNCIL

MAYOR	ROSE ESPINOZA
MAYOR PRO TEM	JOSE MEDRANO
COUNCIL MEMBER	JAMES GOMEZ
COUNCIL MEMBER	DELWIN LAMPKIN
COUNCIL MEMBER	DAREN NIGSARIAN

BID OPENING: Thursday, October 2, 2025, at 3:00 PM

**CITY OF LA HABRA
PUBLIC WORKS DEPARTMENT
ENGINEERING DIVISION**



110 E. LA HABRA BOULEVARD
LA HABRA, CA 90631
(562) 383-4151

**SPECIFICATIONS FOR
ANNUAL SIDEWALK IMPROVEMENTS PROJECT
FY24-25 - CITY PROJECT NO. 1-R-25**

SEPTEMBER 2025

APPROVED BY:

ALBERT MENDOZA, P.E.
DEPUTY DIRECTOR OF PUBLIC WORKS/CITY ENGINEER

9. 8. 25

DATE

TABLE OF CONTENTS

<u>NOTICE INVITING BIDS</u>	A-1
<u>INSTRUCTION TO BIDDERS</u>	B-1
<u>SPECIAL PROVISIONS</u>	C-1
SECTION 1. DEFINITION OF TERMS	C-2
SECTION 2. REQUIREMENTS AND CONDITIONS	C-3
SECTION 3. SCOPE OF WORK	C-7
SECTION 4. CONTROL OF THE WORK	C-8
SECTION 5. CONTROL OF MATERIAL	C-12
SECTION 6. LEGAL RELATIONS AND RESPONSIBILITIES	C-13
SECTION 7. PROSECUTION AND PROGRESS	C-22
SECTION 8. PAYMENTS	C-23
SECTION 9. WORK SCHEDULES	C-24
SECTION 10. CITY REQUIREMENTS	C-24
SECTION 11. CONSTRUCTION DETAILS	C-26
SECTION 12. BID ITEMS FOR ANNUAL SIDEWALK IMPROVEMENT PROJECT FY24-25	C-36
<u>PROPOSAL</u>	D-1
PROPOSAL	D-2
BIDDER'S INFORMATION	D-5
EXHIBIT A, BID SCHEDULE 1	D-6
ACKNOWLEDGEMENT OF ADDENDA RECEIVED	D-8
REFERENCES	D-9
DBE BIDDER'S LIST	D-11
VIOLATIONS OF FEDERAL, STATE, OR LOCAL LAWS	D-12
DISQUALIFICATION OR DEBARMENT	D-13
LIST OF SUBCONTRACTORS	D-14
BID SECURITY FORM	D-15
BID BOND	D-16
NON-COLLUSION AFFIDAVIT	D-17
WORKER'S COMPENSATION CERTIFICATE	D-18
PUBLIC CONTRACT CODE SECTION 10285.1 STATEMENT	D-19
PUBLIC CONTRACT CODE SECTION 10162 QUESTIONNAIRE	D-20
PUBLIC CONTRACT CODE SECTION 10232 STATEMENT	D-21
<u>SAMPLE AGREEMENT</u>	E-1
ARTICLE I	E-2
ARTICLE II	E-3
ARTICLE III	E-5
ARTICLE IV	E-5
ARTICLE V	E-6
ARTICLE VI	E-8
ARTICLE VII	E-10

ARTICLE VIII	E-11
FAITHFUL PERFORMANCE BOND	E-17
PAYMENT BOND	E-18
CERTIFICATION OF COMPLIANCE	E-26

APPENDIX "A", PROJECT PLANS
APPENDIX "B", STANDARD PLANS
APPENDIX "C", LIST OF QUANTITIES

SECTION A

NOTICE INVITING BIDS

CITY OF LA HABRA

NOTICE INVITING BIDS

NOTICE IS HEREBY GIVEN that sealed bids will be received by the City Clerk of the City of La Habra, California for furnishing all labor, services, materials, tools, equipment, supplies, transportation, utilities and all other items and facilities necessary therefor as provided in the Contract Documents for the: **ANNUAL SIDEWALK IMPROVEMENTS PROJECT FY24-25, CITY PROJECT NO. 1-R-25**, in strict compliance with the specifications, plans and contract documents on file at the Office of the City Clerk of the City of La Habra.

DATE OF OPENING BIDS: Bids will be received at the Office of the City Clerk of the City of La Habra until **3:00 P.M. on Thursday, October 2, 2025**, at which time and place the bids will be publicly opened and read aloud. Bids shall be submitted in sealed envelopes marked on the outside: **“ANNUAL SIDEWALK IMPROVEMENTS PROJECT FY24-25, CITY PROJECT NO. 1-R-25. DO NOT OPEN WITH REGULAR MAIL.”**

LOCATION OF WORK: The work to be constructed hereunder is located at various locations within the City of La Habra, County of Orange. Typical work to be done is illustrated on plans and these specifications.

DESCRIPTION OF WORK: The general items of work to be performed hereunder shall be at various locations throughout the City of La Habra and shall consist of but not be limited to Removal and Reconstruction of PCC Sidewalks, Curbs, Gutters, and Driveway Approaches; Removal and Construction of AC Pavement Slot Trench; Restoring Parkway Irrigation Systems; Regrade Landscape; Install Sod; Root Pruning; Tree Removals; Tree Planting; and all incidental work so indicated on the plans, specifications and tables, and required for the proposed improvements.

CONTRACTOR’S LICENSE: The City of La Habra has determined that a Class “A” or “C-8” State Contractor’s License is required for this project.

COMPLETION OF WORK: All work shall be completed within Thirty (30) working days from the start date specified in the Notice To Proceed.

LIQUIDATED DAMAGE: If the total amount of working days have expired and the work is not complete, liquidation damages are Five Hundred Dollars (\$500) per calendar day.

AWARD OF CONTRACT: The City of La Habra reserves the right, after opening the bids, to reject any or all bids, waive any informality or irregularity in such bids, or to award to the lowest responsible bidder and reject all other bids.

PROPOSAL GUARANTEE AND BONDS: Each bid must be accompanied by a certified cashier’s check or by a corporate surety bond on the form furnished by the City of La

Habra, as guarantee that the bidder will, if an award is made to him in accordance with the terms of his bid, promptly secure Worker's Compensation Insurance and Liability Insurance, execute the contract in the required form and furnish satisfactory bonds for the faithful performance of the contract and for the payment of claims of materialmen and workers thereunder. Said check or bidder's bond shall be in an amount of not less than ten percent (10%) of the amount of the bid. The Faithful Performance Bond shall be not less than one hundred percent (100%) of the total amount of the bid price named in the contract. The Payment Bond shall be not less than one hundred percent (100%) of the total amount of the bid price named in the contract. The City of La Habra reserves the right to reject any bond if, in the opinion of the Engineer, the Surety's acknowledgment is not in the form included in the contract documents or in another form substantially as prescribed by law.

PREVAILING RATES OF WAGES: Pursuant to the provisions of Section 1773 of the Labor Code of the State of California, the Director of Industrial Relations has ascertained the general prevailing rate of wages and employer payments for health and welfare, vacation, pension and similar purposes applicable to the work to be done. A copy of said wage rates is available on-line at:

<https://www.dir.ca.gov/dlsr/DPreWageDetermination.htm>

The Contractor and all subcontractors are responsible to pay the prevailing rates of wages that are specified within ten (10) calendar days before the bid open day and shall post a copy of said wage rates at the project site. The statutory provisions for penalties for failure to pay prevailing wages will be enforced (Labor Code §1775) and the statutory provisions for failure to comply with the States' wage and hour laws will be enforced (Labor Code §1813).

DEBARMENT: No Contractor or Subcontractor may be awarded as a contractor on a bid proposal if they have been Debarred by the State pursuant to Labor Code Sections 1777.1 and 1777.7 and Public Contracts Code Section 6109.

APPRENTICE: The Contractor shall comply with all laws, rules, regulations, and all the requirements of the Labor Code including, but not limited to, Section 1776, 1777.5, and 1777.6 of the California Labor Code.

CONTRACT DOCUMENTS: The Contract Documents shall consist of the following: Notice Inviting Bids; Instructions to Bidders; Proposal; Bidder's Information; Bid Schedule; Acknowledgement of Addenda Received; References; DBE Bidder's List; Violations of Federal, State, or Local Laws; Disqualification or Debarment; List of Subcontractors; Bid Security Form; Bid Bond; Non-Collusion Affidavit; Worker's Compensation Certificate; Public Contract Code Section 10285.1 Statement; Public Contract Code Section 10162 Questionnaire; Public Contract Code Section 10232 Statement; Agreement; Faithful Performance Bond; Payment Bond; Certification of Compliance; Special Provisions; Drawings; and the Standard Specifications for Public Works Construction, latest edition and supplements thereto, made a part by reference,

together with all additions, deletions, modifications or interpretations of any of said documents, all of which are hereby made a part of this Notice Inviting Bids.

Specifications are available for inspection, without charge, at the Office of the City Engineer of the City of La Habra.

Complete sets of said plans, specifications, and bid documents can be downloaded at PlanetBids.com.

ADDRESS AND MARKING OF PROPOSAL: The envelope enclosing the proposal shall be sealed and addressed to the City Clerk and hand delivered to the City Clerk at the Civic Center, 110 E. La Habra Blvd (Administration Department), or mailed to City Clerk, Civic Center, 110 E. La Habra Blvd, La Habra, California 90631. The envelope shall be plainly marked in the upper left-hand corner with the name and address of the bidder and shall bear the words "Proposal For" followed by the title of the specifications for the work, and the date and hour of opening bids. The certified or cashier's check, money order, or bidder's bond shall be enclosed in the same envelope with the proposal.

DEPARTMENT OF INDUSTRIAL RELATIONS (DIR) REQUIREMENT: No Contractor or Subcontractor may be listed on a bid proposal for a public works project unless registered with the Department of Industrial Relations (DIR) pursuant to Labor Code 1725.5 and Senate Bill 854. Payroll documents for the contractor and subcontractors should be submitted and registered on time with the DIR.

Under California Labor Code Section 1771.1, in order to be awarded and to perform work on public works projects, prime contractors and subcontractors must possess and maintain registration with the Department of Industrial Relations (DIR) at <https://www.dir.ca.gov/public-works/contractor-registration.html>. This is a separate requirement from the Contractors State License Board (CSLB) licensing requirement. See the Special Provisions for additional details.

SUBMISSION OF QUESTIONS:

- Questions received after Thursday, September 18, 2025 5:00 pm will not be considered.
- Questions or clarifications deemed by the City's to be material change will be answered via issuance of an addendum and posted to the City's online bidding service, PlanetBids.com.
- Only questions answered by formal written addenda shall be binding. Oral and other interpretations or clarifications shall be without legal effect. It is the Bidder's responsibility to be informed of any issued addenda and to include all such information in its Bid.
- Any questions regarding this solicitation shall be submitted electronically to Jay Kasondra – Assistant Civil Engineer at jkasondra@lahabracal.gov.

BID SCHEDULE:

Bid AdvertisementWednesday, September 10, 2025
Requests for Information/Questions...due by Thursday, September 18, 2025, by 5:00 pm
Response to Requested for Information...Tuesday, September 23, 2025, by 5:00 pm
Bid Openingdue by Thursday, October 2, 2025, 3:00 pm

SECTION B
INSTRUCTIONS TO BIDDERS

CITY OF LA HABRA

INSTRUCTIONS TO BIDDERS

The following instructions and conditions apply to the attached bid and the bidder acknowledges the acceptance thereof by signing and filing said bid.

Each bidder shall state whether he is an individual, firm or corporation; if firm, give name of each member; if a corporation, give name of president, secretary, treasurer and manager.

Proposals shall be submitted to the City of La Habra on forms prepared and furnished in the bid documents, or as provided by the Engineering Office of the City of La Habra. When presented, they must be completely made out in the manner and form indicated therein, showing the proposed prices clearly and legibly and must be properly signed by the bidder. Proposals presented otherwise may be rejected.

Each proposal so submitted, together with the required proposal guarantee hereinafter prescribed, shall be presented under sealed cover and must be filed prior to the time and place designated in the Notice Inviting Bids. A proposal so presented, however, may be withdrawn by the bidder provided the request therefor is made in writing, is signed by the bidder or his authorized representative and is filed prior to the time fixed for the opening of bids. The withdrawal of a bid proposal does not prejudice the right of the bidder to file a new bid.

All proposals submitted as hereinabove prescribed will be publicly opened and read at the time and place indicated in the Notice Inviting Bids.

Bids are required for the entire work. The amount of the bid for comparison purposes will be the total of all items.

The bidder shall set forth for each item of work, in words and in clearly legible figures, a unit price and an amount for the item in the respective space provided for this purpose. In the case of unit price items, the amount set forth under the "AMOUNT" column shall be the extension of the unit price bid on the basis of the estimated quantity for the item. In case of discrepancy between the words and figures, the words shall prevail.

In case of discrepancy between the "Unit Price" and the "Amount" set forth for the item, the Unit Price shall prevail. However, if the amount set forth as a Unit Price is ambiguous, unintelligible or uncertain for any cause or is omitted or in the case where the Unit Price is the same amount as the entry in the "AMOUNT" column for the item, the "AMOUNT" price shall prevail in accordance with the following:

- (1) As to lump sum items, the amount set forth in the "AMOUNT" column shall be the unit price.
- (2) As to unit price items, the amount set forth in the "AMOUNT" column shall be divided by the estimated quantity for the item and the price thus obtained shall be the unit price.

In case of discrepancy between the sum of the individual “AMOUNT” prices, and the Total Bid Price, the sum of the individual “AMOUNT” prices will prevail.

Bidders must satisfy themselves by personal examination of the locations of the proposed work and by personal examination of the proposed contract documents as to the actual conditions and the requirements of this work and shall not at any time after submission of the bid dispute, complain or assert that there was any misunderstanding in regard to the nature or the amount of work to be done unless a written change in these specifications or contract or written clarification thereof has been issued by the City of La Habra.

Each bid must be in a sealed envelope which is to be clearly marked so as to identify it as a bid (such as “Sealed Bid - do not open with regular mail”), giving the number and name of the project or specification and the name of the bidder. These instructions are particularly necessary if your bid is transmitted by mail. Failure to identify the project or to address it to the City Clerk, Civic Center, 110 E. La Habra Blvd, La Habra, California 90631, Attention City Clerk, will result in the opening of the envelopes with the regular mail and may thereby void the bid.

The City Council will award the contract to the lowest responsible bidder, however, said Council reserves the right to reject any or all bids, to waive any informality in the bids received and, if necessary, to take said bids under advisement for a period not to exceed sixty (60) days including lead-time.

All proposal requirements and conditions as set forth in the Standard Specifications shall apply hereto.

APPROXIMATE ESTIMATE: The quantities shown in the proposal form and in the estimate included in the bid documents shall be considered as approximate only, being listed therein for the purpose of serving as a general indication of the amount of work or materials to be performed or furnished as a basis for the comparison of bids. The Council does not guarantee nor agree, either expressly or by implication, that the actual amounts required will correspond therewith, but reserves the right to increase or decrease the amount of any item, portion of work to be performed or material to be furnished, or to omit any such item or portion, in accordance with the provisions relative thereto set forth in the bid documents or Standard Specifications under which the work is to be constructed, without in any way invalidating the contract should such increase, decrease or omission be deemed necessary or expedient. The City of La Habra reserves the right to increase or decrease the amount of any item as necessary due to budgetary requirements.

DISADVANTAGED BUSINESS ENTERPRISE (DBE) REQUIREMENTS: The City of La Habra requires that Disadvantaged Business Enterprises (DBEs) have the opportunity to participate in public works projects. To assist the City of La Habra in establishing future Annual Anticipated DBE Participation Level (AADPL), all contractors are required to submit a list of all subcontractors and suppliers, whether DBE or not, contacted during preparation of the bid.

SECTION C
SPECIAL PROVISIONS

SPECIAL PROVISIONS

SECTION 1. DEFINITION OF TERMS

CITY: The City of La Habra

CITY COUNCIL: The City Council of the City of La Habra.

ENGINEER: Any reference to the “Engineer” in the specifications shall be construed to mean the City Engineer of the City of La Habra or his authorized agents.

BIDDER: Any individual, firm or corporation submitting a bid to furnish the materials and equipment and perform the work herein specified, properly made out on the form furnished by the City Engineer, duly executed by the bidder and enclosed within a sealed envelope directed to the City Clerk, Civic Center, 110 E. La Habra Blvd., La Habra, California 90631.

BID FORMS: The blank forms prepared by the City of La Habra on which the bidder must submit the bid.

CONTRACTOR: The bidder whose bid is accepted and to whom the contract is awarded.

CONTRACT: The Specifications, Special Provisions, the notice inviting bids, the bid and addenda of the Contract, and the agreement entered into pursuant thereto shall constitute the Contract between the City of La Habra and the Contractor.

LABORATORY: The designated laboratory authorized by the Engineer to test materials and work involved in the contract.

THE WORK: All the work required to be performed under the contract.

GENERAL CONSTRUCTION TERMS: Unless otherwise specifically defined herein or unless the content requires a different meaning, all words, terms and phrases having a well-known or technical meaning shall be so construed.

USE OF PRONOUNS: Words used herein in the masculine gender include the feminine and neuter and vice versa; the singular number includes the plural and the plural the singular. The word “person” includes a corporation, association or partnership.

SECTION: The part into which these Special Provisions are divided. Each section is designated by a whole number preceding its title.

ARTICLES: The parts into which sections are divided. Each article is designated by a number preceding its title, the first two figures to the right of the decimal point being the number of the article and the figures or figure to the left of the decimal point being the number of the section of which such article is a part. Thus: Article 11.05 indicates Article 5 of Section 11.

SUBDIVISIONS: The parts into which articles are divided. Each subdivision is designated by a number preceding its title, the figure or figures to the right of the article number being the number of the subdivision. Thus: Subdivision 11.05.2 indicates Subdivision 2 of Article 5 of Section 11.

STANDARD SPECIFICATIONS: The document entitled “Standard Specifications for Public Works Construction”, 2024 Edition and supplements thereto, are hereinafter referred to as the Standard Specifications.

Other terms appearing in the Standard Specifications shall have the intent and meaning specified in Section 1 “General” of the Standard Specifications.

In case of conflict between the Standard Specifications and these Special Provisions, these Special Provisions shall take precedence over and be used in lieu of such conflicting portions of the Standard Specifications.

SECTION 2. REQUIREMENTS AND CONDITIONS

ARTICLE 2.01: EXAMINATION OF PLANS, SPECIFICATIONS, SPECIAL PROVISIONS, AND WORKSITE: Bidders must satisfy themselves by personal examination of the proposed work site and by such other means as they may prefer as to the actual conditions and requirements of the work. Bidders shall not at any time after submission of the bid, dispute, complain or assert that there was any misunderstanding in regard to the nature or amount of work to be done.

The CITY, in accordance with Title VI of the Civil Rights Act of 1964 (78 Station 252) and the Regulations of the Department of Commerce (15 C.F.C., Part 8), issued pursuant to such Act, hereby notifies all bidders that it will affirmatively insure that the contract entered into pursuant to this advertisement will be awarded to the lowest responsible bidder without discrimination of the grounds of race, color or national origin.

ARTICLE 2.02 BID FORMS: All bids submitted shall be made on the blank forms provided with the bid documents. Bids submitted on forms other than those provided with the bid documents shall be rejected. All bids shall give the price bid both in writing and figures and shall be signed by the bidder with his address. Bids shall be enclosed in a sealed envelope directed to the City Clerk, Civic Center, 110 E. La Habra Blvd, La Habra, California 90631.

ARTICLE 2.03 IRREGULAR BIDS: Bids may be rejected if they show any alterations of form, additions not called for, conditional bids, incomplete bids, erasures or irregularities of any kind.

ARTICLE 2.04 DISQUALIFICATION OF BIDDERS: The CITY COUNCIL may reject any and all bids should it deem this for the public good and the bid of any party who has been delinquent or unfaithful in any former contract with the CITY, and may reject all bids other than the lowest bid of any responsible bidder and may award the contract for said work or improvement to the lowest responsible bidder at the prices named in his bid.

ARTICLE 2.05 MATERIAL GUARANTEE: Before any bid is accepted, the bidder may be required to furnish a complete statement of the origin, composition and manufacture of any or all

materials to be used in the construction of the work, together with samples which may be subjected to the tests provided for in these Specifications or in the Special Provisions to determine their quality and fitness for the work.

ARTICLE 2.06 BONDS: In lieu of Section 1-7.2 “Contract Bonds” of the Standard Specifications, the Contractor, simultaneously with the execution of the Agreement, shall furnish a surety bond in an amount equal to one hundred (100) percent of the contract price as security for the faithful performance of the contract and a separate surety bond in an amount equal to one hundred (100) percent of the contract price as security for the payment of all persons performing labor and furnishing materials in connection with the contract. Said bonds shall be secured from a Surety Company satisfactory to the CITY.

ARTICLE 2.07 BID GUARANTEE:

Subdivision 2.07.1: All bids shall be presented under sealed cover and shall be accompanied by cash, cashier’s check, certified check or bidder’s bond made payable to the City of La Habra for an amount equal to at least ten percent (10%) of the amount of said bid. No bid will be considered unless such cash, cashier’s check, certified check or bidder’s bond is enclosed therewith.

Subdivision 2.07.2: Return of Bid Guarantee: The bid guarantee of the bidder or bidders who are being considered for the award of Contract shall be held until the execution of said contract, and shall thereupon be returned to the bidder. Bid guarantee of other bidders will be returned to such bidders upon award of the Contract.

ARTICLE 2.08 AWARD OF CONTRACT: The award of contract, if it be awarded, will be within sixty (60) days of the opening of bids.

ARTICLE 2.09 EXECUTION OF CONTRACT: The contract, construction schedule, and bonds shall be executed and filed by the successful bidder with the City Clerk of the City of La Habra not later than ten (10) days after the award of contract.

All bidders may submit with their bids a sworn statement of their financial responsibility, technical ability and experience. Such sworn statement may be required to be furnished before award is made to any particular bidder.

The CITY COUNCIL may, upon the refusal or failure of successful lowest responsible bidder to accept the contract, award it to the second lowest responsible bidder. If the legislative body awards the contract to the second lowest bidder, the amount of the lowest bidder’s security shall be applied by the CITY to the difference between the low bid and the second lowest bid; and the surplus, if any, shall be returned to the lowest bidder if cash or a check is used, or to the surety company if bidder’s bond is used.

ARTICLE 2.10 BEGINNING OF WORK: The Contractor shall begin work from the start date specified in the Notice To Proceed.

ARTICLE 2.11 PLANS AND SPECIFICATIONS: Specifications and bid documents are on file at the Office of the City Engineer, Civic Center, 110 E. La Habra Blvd., La Habra and can be downloaded as a digital copy of said Contract Documents (saved in PDF format) are available free of charge posted at the following website:

<http://www.PlanetBids.com/>

ARTICLE 2.12 CONTRACT DOCUMENTS: The Contract Documents shall consist of the following: Notice Inviting Bids; Instructions to Bidders; Proposal; Bidder's Information; Bid Schedule; Acknowledgement of Addenda Received; References; DBE Bidder's List; Violations of Federal, State, or Local Laws; Disqualification or Debarment; List of Subcontractors; Bid Security Form; Bid Bond; Non-Collusion Affidavit; Worker's Compensation Certificate; Public Contract Code Section 10285.1 Statement; Public Contract Code Section 10162 Questionnaire; Public Contract Code Section 10232 Statement; Agreement; Faithful Performance Bond; Payment Bond; Certification of Compliance; Special Provisions; Drawings; and the Standard Specifications for Public Works Construction, latest edition and supplements thereto, together with all additions, deletions, modifications, appendices and all addenda as prepared prior to the date of the bid opening setting forth any modifications or interpretations of any said documents are hereby incorporated in and made a part of the Contract Documents.

All Contract Documents are complementary, and what is called for in any one shall be as binding as if called for in all. The intention of the documents is to require a complete and finished piece of work. The Contractor, at his sole cost and expense, shall perform all labor and services and shall furnish all materials, tools, equipment and facilities necessary for the proper execution of the work, with the exception of such items as may be definitely stipulated in the Specifications or on the Plans to be furnished by the CITY. Anything shown on the Plans and not in the Specifications, or in the Specifications and not in the Plans, shall be performed by the Contractor as though shown on both the Plans and Specifications.

Documents which shall be signed and returned to the CITY with Bid Proposal are:

Proposal; Bidder's Information; Bid Schedule; Acknowledgement of Addenda Received; References; DBE Bidder's List; Violations of Federal, State or Local Laws; Disqualification or Debarment; List of Subcontractors; Bid Security Form; Bid Bond; Non-Collusion Affidavit(s) (Principal and Subcontractor); Worker's Compensation Certificate; Public Contract Code Section 10285.1 Statement; Public Contract Code Section 10162 Questionnaire; and Public Contract Code Section 10232 Statement.

Documents which are to be signed and returned to the CITY by the winning bidder are:

Agreement; Faithful Performance Bond; Labor and Material Payment Bond; Supplemental Information to Be Completed by Principal; Tax Identification Number; Bid Guarantee; Statement of Non-Collusion by Contractor; Certification of Compliance; Liability Insurance; and Workers Compensation Insurance.

Subdivision 2.12.1 Precedence Of Contract Documents: If there is a conflict between Contract Documents, the order of precedence shall be as follows:

1. Contract
2. Specifications
3. Plans

Within the Specifications, the order of precedence is as follows:

1. Change Orders
2. Addenda
3. Permits from other agencies/Supplemental Agreements
4. Special Provisions
5. Instructions to Bidders
6. Notice Inviting Bids
7. Referenced Standard Drawings
8. Referenced Standard Specifications

With reference to Plans, the order of precedence is as follows:

1. Change Order drawings govern over Addenda and Contract drawings.
2. Addenda drawings govern over contract drawings.
3. Contract drawings govern over shop drawings and Standard drawings.
4. Detail drawings govern over general drawings.
5. Figures govern over scaled dimensions.

ARTICLE 2.13 AUTHORITY OF THE ENGINEER: The Engineer shall have the authority to direct as may be necessary to ensure that the work is in strict compliance with the Contract Documents; determine the quantity, quality and soundness of the work; determine if material and equipment being used is satisfactory; interpret the requirements of the contract; and, make decisions regarding the progress and execution of the work. However, neither the Engineer nor any representative of the Engineer shall have the authority to authorize extra work without prior approval by the CITY COUNCIL. Should any discrepancy appear or any misunderstanding arise as to the importance of anything contained in the Specifications or Plans, the matter shall be referred to the Engineer, who shall decide the same in accordance with the true intent and meaning as construed by him. Any difference or conflicts which may arise between the Contractor and any other contractor also under the contract administration of the Engineer shall be arbitrated by the Engineer.

ARTICLE 2.14 ACCESS TO WORK: The Engineer, his agents and duly authorized representatives of the CITY shall at all times and for any purpose, have access to the work and the premises used by the Contractor and the Contractor shall provide safe and proper facilities therefor.

ARTICLE 2.15 LEGAL ADDRESS OF THE CONTRACTOR: The address given in the Proposal is hereby designated as the place to which all notices, letters and other communications to the Contractor shall be mailed or delivered. The mailing or delivering to the above-named place of any notice, letter or other communication to the Contractor, shall be deemed sufficient service thereof

upon the Contractor. The date of said service shall be the date of such mailing or delivery. Such address may be changed at any time by a written notice signed by the Contractor and delivered to the Engineer.

ARTICLE 2.16 CONTRACTOR'S RESPONSIBILITIES: The Contractor shall be responsible for the safe, efficient and adequate use of equipment during the progress of the work so as to secure the safety of the workers and others. The Contractor is also responsible for the quality of work required and the stipulated rate of progress. It shall be the Contractor's responsibility to perform the work strictly in accordance with the Specifications and Plans or in accordance with modifications as may be made by the Engineer in the form of addendum or written change orders. The presence of the Public Works Inspector does not relieve the Contractor of his obligation to comply with the requirements of the Plans, Specifications and Contract Documents.

The Contractor shall assume the defense of and indemnify and save harmless the CITY and its officers and agents from all claims of any kind arising from his own negligence or that of his agents in the performance of the Contract.

The Contractor shall be responsible for the custody of any material furnished to him for the care of all work until its completion and final acceptance. He shall, at his own expense, replace damaged or lost material and repair damaged parts of the work, regardless of cause, or the same may be done at the Contractor's expense by the CITY.

During the progress of the work the Contractor shall keep the worksite in a neat and clean condition and free from any unsightly accumulation of rubbish. If stockpiling is necessary, the material shall be removed or disposed of weekly. He shall remove from the vicinity of the completed work all plant, building, rubbish, unused materials, concrete forms and equipment belonging to him or used under his direction during construction. In the event of his failure to do so, the same may be removed by the CITY at the Contractor's expense.

All operations of the Contractor shall be conducted in such a manner as to avoid unnecessary dust. To this end, the Contractor shall provide equipment, materials, water, and labor to keep all parts of the work adequately sprinkled and dust free as determined by the Engineer. Full compensation for dust control measures and conforming with the provisions of this Section shall be included in the prices paid for the various contract items of work listed in the Bid Schedule, and no additional compensation will be allowed therefor.

SECTION 3. SCOPE OF WORK

ARTICLE 3.01 WORK TO BE DONE: The Contractor shall for the price bid furnish all the necessary labor, materials, equipment, methods, processes, implements, tools, and machinery except as otherwise specified to perform the required work in a thorough and workmanlike manner in accordance with the plans and specifications, and to the satisfaction of the Engineer.

The work comprises the furnishing of all materials, equipment, tools, labor and incidentals as required by the Plans, Specifications and Contract Documents for the above stated project. The general items of work to be performed hereunder shall be at various locations throughout

the City of La Habra and shall consist of but not be limited to Removal and Reconstruction of PCC Sidewalks, Curbs, Gutters, and Driveway Approaches; Removal and Construction of AC Pavement Slot Trench; Restoring Parkway Irrigation Systems; Regrade Landscape; Install Sod; Root Pruning; Tree Removals; Tree Planting; and all incidental work so indicated on the plans, specifications and tables, and required for the proposed improvements.

ARTICLE 3.02 FINAL CLEANING UP: Before acceptance of the work and final payment therefor, the Contractor shall clean the work and all ground occupied by him in connection with the work, of all rubbish, excess materials, equipment and forms. All parts of the work shall be left in a neat and presentable condition.

ARTICLE 3.03 REPAIRS AND REPLACEMENTS: All damage done to existing facilities and improvements by the Contractor shall be repaired by him to the satisfaction of the Engineer. Where sidewalks, curbs or gutters are to be repaired, the repairs shall be made by removing and replacing the entire section back to the nearest scoring lines and not by refinishing the damaged portion.

SECTION 4. CONTROL OF THE WORK

ARTICLE 4.01 COORDINATION OF PLANS, SPECIFICATIONS AND SPECIAL PROVISIONS: These specifications, drawings, special provisions and all supplementary documents are essential parts of the contract. A requirement occurring in one is as binding as though occurring in all. The drawings and specifications are intended to be cooperative and to describe and provide for the workmanlike completion of proposed improvements. Refer to Subdivision 2.12.1 for precedence of Contract Documents.

ARTICLE 4.02 SPECIFICATIONS AND DRAWINGS: The Contractor shall keep at the work site a copy of the Specifications and Plans at all times and provide the Engineer access thereto.

The Contractor shall check all dimensions and quantities on the drawings or schedules herein contained or given to him by the Engineer, and shall notify the Engineer of errors therein which may be discovered by examining and checking the drawing. He shall not take advantage of any error or omission in these specifications, drawings or schedules, but should such error or omission be discovered, the Contractor shall notify the Engineer and the Contractor shall carry out the Engineer's instructions, as if originally specified.

ARTICLE 4.03 SUPERVISION BY THE CONTRACTOR: The Contractor shall give his personal superintendence to the work, using all his skills and attention in directing the performance of the work or he shall provide a competent, full-time superintendent or foreman with the authority to act on his behalf and whom shall be present to direct the work on the project at all times during its progress. All directions given to the Contractor's superintendent or other authorized supervisory employee shall be as binding as if delivered to the Contractor personally.

ARTICLE 4.04 LABOR: Any overseer, superintendent, laborer or other person employed by the Contractor who shall perform his work in a manner contrary to the specifications shall be discharged immediately and such person shall not again be employed on the project.

ARTICLE 4.05 LINES AND GRADES: The Contractor will set all lines and grades in accordance with the plans and all work done shall conform thereto. The Contractor shall dig all stake holes necessary to give lines and grades. The Contractor shall preserve all stakes set for lines, grades or measurements of the work in their proper places until authorized to remove them by the Engineer. Any expense incurred in replacing stakes which the Contractor or his subordinates may have failed to preserve shall be borne by the Contractor. Unless otherwise noted, the grade between two grade points shall be a straight line between such two points.

ARTICLE 4.06 INSPECTION: The Contractor shall notify the Engineer at least 48 hours in advance of starting or resuming work so that the Engineer can arrange for an assistant engineer or inspector to be present. Failure to give such notice shall be cause for rejection of such work. The Contractor shall furnish the engineers and inspectors reasonable facilities for obtaining such information as may be necessary to give them full information at all times respecting the progress and manner of doing the work and the character of the materials.

Subdivision 4.06.1 Special Inspection Fees: If the Contractor elects to work under this contract more than 8 hours per day and 40 hours per week; or Saturday, Sunday, overtime, or CITY Holidays, the Contractor shall arrange with the Engineer for the required inspection service and pay the special inspections fees which will be charged at the following rates:

Monday through Friday	\$150.00 / hour
Saturday, Sunday, overtime and Holidays	\$200.00 / hour

ARTICLE 4.07 DEFECTIVE WORK OR MATERIALS: Inspection of the work shall not relieve the Contractor of his obligation to fulfill his duty as herein prescribed. Defective work shall be made good by the Contractor. Unsuitable work and materials may be rejected notwithstanding that such work and materials were previously inspected by the Engineer and accepted or estimated for payment. If the work, or any part thereof, is determined to be defective at any time before final acceptance of the work, the Contractor shall forthwith make good such defect without additional compensation in a manner satisfactory to the Engineer.

If materials furnished and brought upon the job site by the Contractor for use in the work, or selected for the same by him shall be condemned by the Engineer as unsuitable or not in conformity with the Specifications, the Contractor shall forthwith discard such materials and remove them to a satisfactory distance from the vicinity of the work.

If the Contractor fails or neglects to make ordered repairs to defective work, or to remove rejected materials from the work site within 10 days after notification by the Engineer, the Engineer acting on behalf of the CITY may make the ordered repairs or remove the condemned materials and deduct the cost thereof from monies due to the Contractor.

ARTICLE 4.08 EQUIPMENT AND PLANT: Equipment not suitable to produce the quality of work required will not be permitted to operate on the project.

Plants, tools and equipment shall be designed and constructed in accordance with general practice for such equipment and shall be of sufficient capacity and of such character to insure the production

of sufficient material to take the work to completion within the scheduled time frame. The Contractor shall provide adequate and suitable equipment and plants to meet the above requirements and when ordered by the Engineer shall remove unsuitable equipment from the worksite and discontinue receiving materials from unsatisfactory plants.

ARTICLE 4.09 ADDITIONS OR OMISSIONS OF WORK, LABOR OR MATERIALS:

Subdivision 4.09.1: Additions: The Contractor shall make additional excavations, furnish and place additional imported borrow, plant-mixed surfacing, concrete or do other additional work or furnish other additional materials where the necessity for or the extent of such work or materials does not appear and cannot with reasonable diligence, cost and certainty, be determined in advance or will only be disclosed by the doing of the work or in any contingency which reasonable care and consideration could not be foreseen. Such additional work or materials shall be specified in writing by the Engineer, subject to approval of the CITY COUNCIL, and shall be paid for at the unit prices set for in the contract.

Subdivision 4.09.2: Omissions: The Contractor shall omit any portion of the work, labor or materials required to be done or furnished under the plans and the specifications when the necessity for the omission of said work, labor or materials does not appear and cannot with reasonable certainty, diligence and cost be ascertained in advance or will only be disclosed by the doing of the work or in any contingency which reasonable care and consideration could be foreseen; which said omission of work, labor or materials shall be specified and required in writing by the Engineer, subject to the approval of the CITY COUNCIL, and shall be deducted from the contract price at the unit prices therefore set forth in said contract. Where the contract price is a lump sum, then the cost of the amount deducted shall be proportion of said lump sum such as the quantity of work, labor or materials omitted bears to the quantity upon which said lump sum is based.

Subdivision 4.09.3: Mark-Ups For Extra Work: The Contractor shall use the specified mark ups for all approved extra work:

For General Contractor's work, 15% mark-up for materials and equipment; and 20% mark-up for labor.

For Subcontracted work, 10% mark-up for the first \$5,000; and 5% mark-up for costs in excess of \$5,000.

No mark-up for bonds shall be allowed.

Subdivision 4.09.4: Tool and Equipment Rental: The rates to be used in determining equipment rental costs shall be as listed in the Caltrans "Labor Surcharge and Equipment Rental Rates" publication in effect at the time of bid.

ARTICLE 4.10 FINAL INSPECTION: The Engineer will not make the final inspection until the work provided and contemplated by the contract has been completed and the final clean-up performed.

ARTICLE 4.11 CONTRACTOR REPORTING REQUIREMENTS: The following items shall be required as a part of Contractor payment requests. Incomplete submittal or omission of any of the following requirements shall be cause for rejection and return of payment requests to the Contractor for correction. All items shall be complete and current to the satisfaction of the Engineer. The Contractor shall provide all information for his own firm as well as each and every subcontractor. Payment requests shall include at least the following items:

- Breakdown of each pay item showing locations and quantities of work requested for payment.
- Certification that the as-built records are current and documented in writing.
- Submission of DBE information including DBE amounts completed to date, DBE providers, Monthly DBE Trucking Utilization Report, and certification that the Contractor is meeting DBE contractual requirements.
- Certified Payroll Reports.
- Updated work schedule.
- All change order requests complete to date, including all Force Account cost supporting documentation.
- Copies of all applicable Best Management Practices reports, and certification that BMP's are current and implemented.
- Copies of test results (if testing is required of Contractor).
- Survey records, maps, cut sheets, calculations, and other data.
- Subcontractor Change Requests and subcontractor data.
- Other forms or reports as may be required by contract.

ARTICLE 4.12 PENALTIES: Notwithstanding penalty provisions elsewhere in these specifications, the CITY may impose financial penalties in the case of the Contractor not fulfilling his contractual obligations. These obligations include, but are not limited to, performing work within the time limits of the contract; public notification; implementation of Best Management Practices, SWPPP, and other management plans; maintaining records; notification of the Engineer; traffic control; safety; controlling the work area; maintaining a competent supervisor on site at all times while performing work; surveying; testing; updating of schedules; and other such contractual obligations. The Contractor shall be responsible for all obligations and penalties applied to subcontractors as if he himself were performing the work.

The amount of penalty shall be equal to the daily liquidated damages, prorated for each 15 minute period, or portion of 15 minutes, of contract violation. Each violation shall be additive if multiple violations occur during the same time period.

ARTICLE 4.13 REMOVAL OF PERSONNEL: The Engineer reserves the right to direct the Contractor to remove any specified personnel from the project at any time without reason. If directed, the Contractor shall immediately remove such personnel from the project site, and replace such with another competent person. This requirement shall apply to subcontractor personnel as if they were the Contractor's personnel. Violation shall be subject to penalties as noted elsewhere in these specifications.

SECTION 5. CONTROL OF MATERIAL

ARTICLE 5.01 DRAWINGS AND INFORMATION REQUIRED OF CONTRACTOR: The Contractor shall before proceeding with the fabrication or erection of structures or appurtenances if called for under the contract and required in its erection thereof, furnish the Engineer with the information regarding same and shall submit to the Engineer for approval drawings, specifications, lists and graphs as required under these specifications. Said drawings, specifications, lists and graphs shall become the property of the CITY. In the event that the Engineer shall find that the drawings, specifications, lists and graphs as submitted by the Contractor, are in accordance with acceptable practice and meet the requirements of these specifications, the Engineer will return one (1) set of drawings and lists with his approval within 10 days after their receipt at the Engineer's office; otherwise, said drawings will be returned to the Contractor within the said 10 day period with a statement of the points wherein they have been found unsatisfactory, in which case, the Contractor at his own expense, shall proceed at once to revise said drawings and lists until they shall be found satisfactory by the Engineer and are approved by him. No fabrication shall be done prior to approval of drawings and lists. The Contractor shall have no claim for damages or extension of time on account of any delay due to revision of drawings as found necessary by the Engineer in order to fulfill the requirements of these specifications; but, regardless of such delays, the Contractor shall be liable to the CITY as provided in the specifications for any failure to complete the work as required by the terms of the contract. Revisions shown on shop drawings shall be considered as changes necessary to meet the requirements of specifications and shall not be taken as the basis of claims for extra work.

The approval of all drawings by the Engineer shall apply to general design only and shall in no way relieve the Contractor from responsibility for errors or omissions contained therein; nor shall said approval operate to waive or modify any provisions or requirement contained in these specifications.

ARTICLE 5.03 STORAGE OF MATERIALS: Materials shall be so stored as to insure the preservation of their quality and fitness for the work. When considered necessary by the Engineer, they shall be placed on wooden platforms or other hard, clean surfaces and not on the ground. They shall be placed under cover when so directed. Stored materials shall be so located as to facilitate prompt inspection.

ARTICLE 5.04 SUBSTITUTION OF EQUIVALENTS: On demand of the CITY COUNCIL, the Bidder shall, at his own expense, furnish information or data concerning the article, equipment, material or process offered by him as an equivalent to that specified; and, if the CITY COUNCIL shall so require, the Bidder, at his own expense, shall have the article, equipment, materials or process tested to its quality, strength, physical, chemical or other characteristics, its durability, finish, efficiency or service by a reputable testing engineer or laboratory satisfactory to the CITY COUNCIL.

SECTION 6. LEGAL RELATIONS AND RESPONSIBILITIES

ARTICLE 6.01 LAWS TO BE OBSERVED AND DISPUTE RESOLUTION:

Subdivision 6.01.1 Laws and Regulations: The Contractor shall keep himself fully informed of all Federal and State laws, County and CITY ordinances and regulations which, in any manner, affect those engaged or employed on the work, the materials used in the work or the conduct of the work. If any discrepancy or inconsistency should be discovered in this contract or in the Plans or Specifications herein referred to, in relation to any such law, ordinance or regulation, the Contractor shall forthwith report the same in writing to the Engineer. The Contractor shall, at all times, observe and comply with and shall cause all his agents and employees to observe and comply with all such applicable laws, ordinances and regulations in effect or which may become effective before completion of this contract. He shall protect and indemnify the CITY and its officers and agents against any claim or liability arising from or based on the violations of any such laws, ordinances or regulations whether by himself or by his employees or his subcontractors or their employees.

Except as otherwise explicitly provided in these specifications, all permits and licenses necessary to the prosecution of the work shall be secured by the Contractor at his own expense and he shall pay all taxes properly assessed against his equipment or property used or required in connection with the work.

All state laws, all county and CITY ordinances and regulations now imposed by competent authority and relating to any materials required to be furnished under these specifications and work required to be done hereunder, shall be deemed to be and hereby are made controlling and part of these specifications.

Subdivision 6.01.2 General: The Contractor shall keep himself fully informed of all existing state and national laws and municipal ordinances and regulations which in any manner affect those engaged or employed in the work, or the materials used in the work or which in any way affect the conduct of the work and of all such orders and decrees of bodies or tribunals having any jurisdiction or authority over the same.

Subdivision 6.01.3 Eight-Hour Law: Eight (8) hours labor constitutes a legal day's work. The Contractor shall forfeit as a penalty twenty-five dollars (\$25.00) for each workman employed in the execution of the contract by the Contractor or any subcontractor under him for each calendar day during which such workman is required or permitted to work more than eight (8) hours in any one calendar day and forty (40) hours in any one calendar week in violation of the provisions of the Labor Code and in particular, Section 1810 to Section 1815 thereof inclusive except that work performed by employees of Contractors in excess of eight (8) hours per day and forty (40) hours during any one week, shall be compensated at not less than one and one-half (1 ½) times the basic rate of pay as provided in Section 1815.

Subdivision 6.01.4 Prevailing Rate of Per Diem Wages: Pursuant to the provisions of Section 1773 of the Labor Code of the State of California, the Director of Industrial Relations has ascertained the general prevailing rate of wages and employer payments for health and welfare, vacation, pension and similar purposes applicable to the work to be done.

The Contractor shall comply with Labor Code Section 1775. In accordance with said section, the Contractor shall forfeit as a penalty to the CITY fifty dollars (\$50.00) for each calendar day, or portion thereof, for each workman paid less than the stipulated prevailing rates for such work or craft in which such workman is employed for any work done under the contract by him or by any subcontractor under him in violation of the provisions of the Labor Code and in particular Labor Code Sections 1770 to 1780, inclusive. In addition to said penalty and pursuant to said Section 1775, the difference between such stipulated prevailing wage rates and the amount paid to each workman for each calendar day or portion thereof for which each workman was paid less than the stipulated prevailing wage rate shall be paid to each workman by the Contractor.

Subdivision 6.01.5 Certified Payroll: Pursuant to Section 1776 of the Labor Code, the Contractor and/or subcontractors shall submit weekly to the CITY for each week in which any contract work is performed a certified copy of all payroll records. Should the Contractor fail to provide such payroll certificates, the CITY may withhold one thousand dollars (\$1,000) for each weekly payroll certificate not received from payment due.

Subdivision 6.01.6 Governing Law, Venue, Dispute Resolution and Attorneys' Fees: This Agreement will be governed by and construed in accordance with laws of the State of California. Specifically, Government Code Section 9204 (A summary of which is set forth in Subdivision 6.01.7). If any disputed portion of the claim is not resolved with the procedure set forth in Subdivision 6.01.7 herein, prior to commencing suit in a court of competent jurisdiction, any unresolved portion of any controversy, dispute or claim arising out of the Agreement will first be submitted to an alternative dispute resolution process as set forth in Subdivision 6.01.8 herein. Any action at law or in equity brought by either of the parties hereto for the purpose of enforcing a right or rights provided for by this Agreement will be tried in a court of competent jurisdiction in the County of Orange, State of California. In the event either party hereto will bring suit to enforce any term of this Agreement or to recover any damages for and on account of the breach of any term or condition of this Agreement, it is mutually agreed that the prevailing party in such action will recover all costs thereof, including reasonable attorneys' fees, to be set by the court in such action.

Subdivision 6.01.7 Summary of Government Code Section 9204: A “claim” is a separate demand on the CITY by a Contractor on a public works project and sent by registered mail or certified mail with return receipt requested, for one or more of the following:

- A time extension, including relief from penalties for delay;
- Payment by the CITY of money damages under the terms of the contract;
- Payment of an amount that is disputed by the CITY.

Initial Review. The claim must be supported by appropriate documentation. The CITY has forty-five (45) days within which to review the claim and provide the Contractor with a written statement identifying the disputed and undisputed portions of the claim. If the CITY does not issue a written statement, the claim is deemed rejected in its entirety. The CITY will pay any undisputed portion of the claim within sixty (60) days of issuing the statement.

Meet & Confer. If the Contractor disputes the CITY's written response, or if the CITY does not issue one, the Contractor may request in writing an informal conference to meet and confer for possible settlement of the claim. The CITY will schedule the meet and confer conference within thirty (30) days of this request and provide a written statement identifying the remaining disputed and undisputed portions of the claim within ten (10) business days of the meet and confer. The CITY will pay the undisputed portion within sixty (60) days of issuing this statement.

Mediation. With respect to any disputed portion remaining after the meet and confer, the CITY and Contractor must submit the matter to nonbinding mediation, agree to a mediator within ten (10) business days after issuing the written statement, and share mediation costs equally. If mediation is unsuccessful, then the terms of the public works agreement and applicable law will govern resolution of the dispute.

Miscellaneous Provisions. Amounts not paid by the CITY in a timely manner bear interest at 7% per annum. Subcontractors may submit claims via this procedure through the general contractor. The CITY and Contractor may waive the requirement to mediate, but cannot otherwise waive these claim procedures.

Subdivision 6.01.8 Alternative Dispute Resolution: In the event that there is any controversy, dispute or claim arising out of or relating to this Agreement, which have not been resolved pursuant to the process summarized in Subdivision 6.01.7 herein, the parties hereto will consult and negotiate with each other and, recognizing their mutual interest, attempt to reach a solution satisfactory to both parties. If they do not reach settlement within a period of sixty (60) days, the matter will be submitted to nonbinding arbitration ("Process") by written notice from either party to the other. The parties will meet and confer in good faith and select an arbitrator that is agreeable to both sides. The Process will be completed no later than one hundred twenty (120) days ("Process Period") after tender of the aforementioned written notice, unless the Parties mutually agree to an extension of the Process Period. If the matter is not successfully resolved by the Process, within the Process Period, the parties are free to commence litigation in a court of competent jurisdiction as defined in Subdivision 6.01.6 herein. Any litigation commenced without both parties' consent prior to the end of the Process Period, will be subject to a stay until the end of the Process Period. The Parties further agree to equally bear the cost of the Process.

ARTICLE 6.02 PERMITS AND LICENSES: The Contractor shall procure all permits and licenses, pay all charges and fees, and give all notice necessary and incident to the due and lawful prosecution of the work. No fee is charged for an Encroachment Permit issued by the CITY for a Public Works Project. The Contractor and his subcontractors shall obtain a CITY Business License.

Full compensation for conforming to the requirements in this article shall be considered as included in the price bid for the various contract items of work involved and no additional compensation will be allowed therefor.

ARTICLE 6.03 PATENTS: The Contractor shall assume all costs arising from use of patented materials, equipment, devices or processes used on or incorporated in the work and agrees to indemnify and save harmless the CITY, the CITY COUNCIL, the City Engineer and their fully

authorized representatives from all suits of law or actions of every nature for, or on account of, the use of any patented materials, equipment, devices or processes.

ARTICLE 6.04 PRESERVATION OF PROPERTY: The Contractor shall conduct the operations in a careful and prudent manner to avoid damage to adjacent property.

The Contractor shall preserve and protect all on-site and roadside trees from injury. All trees useful for shade or other purposes shall be cared for by the Contractor and no trees within the limits of project site shall be cut or removed unless indicated on the plans.

All fences along the line of the improvement shall be protected by the Contractor; if they are injured or destroyed they shall be restored to a condition as good as when he entered upon the work. It is required that the Contractor replace in kind or reimburse the owners thereof for all fences, shrubs, buildings and other improvements damaged or removed by the construction operations not shown on the plans.

The Contractor shall preserve and protect from damage to all buildings, pole lines, pipe lines and all direction, warning and mileage signs and any other structures which have been placed within the limits of the project site.

Full compensation for conforming to the requirements in this article shall be considered as included in the price bid for the various contract items of work involved and no additional compensation will be allowed therefor.

ARTICLE 6.05 PRESERVATION OF MONUMENTS: The Contractor shall not disturb any monuments, stakes or sign posts found on the line of the improvement until authorized by the Engineer. The Contractor shall bear the expense of resetting any monument, stakes or sign posts which may be disturbed without authorization from the Engineer. After construction and prior to final acceptance, the Contractor's land surveyor or qualified Civil Engineer shall re-survey all field monuments and centerline ties within the construction zone, prepare tie sheets and Corner Record sheets, and file them with the City Engineer for review. After review by the City Engineer, the land surveyor shall file the Corner Records with the Orange County Land Surveyors Office as required by law, and file certified copies of the Corner Records with the City Engineer. Project retention will not be released until all records are recorded with the County Land Surveyor Office.

ARTICLE 6.06 RESPONSIBILITY FOR DAMAGE: During the progress of the work, the CITY will not be answerable or accountable, in any manner, for any loss or damage that may happen to the work or any part thereof; or for injury to any person or persons, either workmen or the public, or for damage to adjoining property from any cause which might have been prevented by the Contractor or his workmen or any one employed by him, against all of which injuries or damages to persons and property the Contractor having control over such work must properly guard. The Contractor shall be responsible for any damage to any person or property resulting from defects or obstructions or from any causes whatsoever during the progress of the work, or at any time before its completion and final acceptance and shall indemnify and save harmless the CITY and/or its officers and/or its employees from all suits or actions of every name and description brought for or on account of any injuries or damages received or sustained by any person or persons by or from the Contractor, his

servants or agents in the construction of the work or by or in consequence of any negligence in guarding the same in improper materials used in its construction or by or on account of any act or omission of the Contractor or his agents.

ARTICLE 6.07 COOPERATION BETWEEN CONTRACTORS: Where two or more contractors are employed on related or adjacent work, each shall conduct his operations in such a manner as not to cause any unnecessary delay or hindrance to the other. Each contractor shall be responsible to the other for all damage to work, person or property or for loss caused by failure to finish the work within the time specified for completion.

ARTICLE 6.08 CONTRACTOR'S RESPONSIBILITY FOR WORK: Except as provided above, until the formal acceptance of the work by the CITY COUNCIL, the Contractor shall have the charge and care thereof and shall bear the risk of injury or damage to any part thereof by the action of the elements or from any other cause whether arising from the execution or from the non-execution of the work. The Contractor shall rebuild, repair, restore and make good all injuries or damages to any portion of the work occasioned by any of the above causes before its completion and acceptance and shall bear the expense thereof except for such injuries or damages as occasioned by acts of the Federal Government and the public enemy. In case of suspension of work from any cause whatever, the Contractor shall be responsible for all materials and shall properly store them, if necessary, and shall provide suitable drainage of the project site and erect temporary structures where necessary.

ARTICLE 6.09 NO PERSONAL LIABILITY: Before the contract is executed on behalf of the CITY, a bidder to whom the contract has been awarded shall furnish to the CITY a policy or certificate of protective liability insurance in which the CITY shall be named as an additional insured with the bidder. The policy shall insure the CITY, his officers, and his employees; the bidder, his employees and his subcontractors and their employees, their heirs, agents and employees; while acting within the scope of their duties against all claims arising out of or in connection with the work to be performed and shall remain in full force and effect until the work is accepted by the CITY. The policy shall provide for the following limits:

Minimum Scope of Insurance.

A. Workers Compensation & Employers Liability Insurance

- Workers Compensation insurance with statutory limits as required by the Labor Code of the State of California.
- Employers Liability with limits of \$1,000,000 per Accident; \$1,000,000 Disease per employee; \$1,000,000 Disease per policy.
- The policy shall include a written waiver of the insurer's right to subrogate against CITY.
- Required Evidence of Coverage:
 1. Subrogation waiver endorsement; and
 2. Properly completed Certificate of Insurance.

B. General Liability Insurance

- Commercial General Liability Insurance no less broad than Insurance Services Office (ISO) form CG 00 01.

- Coverage shall be on a standard occurrence form. Claims-Made forms are not acceptable without prior written consent. Modified, limited or restricted Occurrence forms are not acceptable without prior written consent.
- Minimum Limits: \$2,000,000 per Occurrence; \$4,000,000 General Aggregate; \$4,000,000 Products/Completed Operations Aggregate. The General Aggregate shall apply separately to each project. The required limits may be provided by a combination of General Liability Insurance and Commercial Excess or Umbrella Liability Insurance. If contractor maintains higher limits than the specified minimum limits, CITY requires and shall be entitled to coverage for the higher limits maintained by contractor.
- Any deductible or self-insured retention shall be shown on the Certificate of Insurance. If the deductible or self-insured retention exceeds \$25,000 it must be approved in advance by CITY. Contractor is responsible for any deductible or self-insured retention and shall fund it upon CITY'S written request, regardless of whether Contractor has a claim against the insurance or is named as a party in any action involving CITY.
- Coverage shall be continued for one (1) year after completion of the work.
- CITY shall be endorsed as an additional insured for liability arising out of ongoing and completed operations by or on behalf of the contractor. CITY shall continue to be an additional insured for completed operations for (1) year after completion of the work.
- The policy definition of "insured contract" shall include assumptions of liability arising out of both ongoing operations and the products-completed operations hazard ("F" definition of insured contract in ISO form CG 00 01, or equivalent).
- The insurance provided to the additional insureds shall be primary to, and non-contributory with, any insurance or self-insurance program maintained by them.
- The policy shall cover inter-insured suits and include a "Separation of Insureds" or "severability" clause which treats each insured separately.
- The policy shall be endorsed to include a written waiver of the insurer's right to subrogate against all persons or entities that are, or are required to be, additional insureds.
- The policy shall not contain a Contractors' Warranty or other similar language which eliminates or restricts insurance because of a subcontractor's failure to carry specific insurance or to supply evidence of such insurance.
- Required Evidence of Coverage:
 1. Copy of the additional insured endorsement or policy language granting additional insured status;
 2. Copy of the endorsement or policy language indicating that coverage applicable to the additional insureds is primary and non-contributory;
 3. Properly completed Certificate of Insurance; and
 4. Completed and signed Agent/Broker Questionnaire with supporting documentation as required.

C. Automobile Liability Insurance

- Minimum Limit: \$2,000,000 combined single limit per accident.
- Coverage shall apply to all owned, hired and non-owned vehicles.

- CITY shall qualify as an insured.
- Required Evidence of Coverage:
 1. Copy of the endorsement or policy language indicating that CITY is an insured; and
 2. Properly completed Certificate of Insurance.

D. Surety Bonds

- Bid bond.
- Performance and payment bonds for the entire contract price.
- The surety must be authorized to issue these bonds in the State of California.

E. Standards for Insurance Companies

- Insurers, other than the California State Compensation Insurance Fund, shall have an A.M. Best's rating of at least A:VII.

F. Documentation

- The Certificate of Insurance shall include the following reference: [Annual Sidewalk Improvements Project, FY24-25, Project No. 1-R-25]
- The name and address for Additional Insured endorsements and Certificates of Insurance is: City of La Habra
- Contractor shall provide immediate written notice if : (1) any of the required insurance policies is terminated; (2) the limits of any of the required policies are reduced; or (3) the deductible or self-insured retention is increased.
- Current Evidence of Coverage shall be provided for the entire required period of insurance.
- Upon written request, certified copies of required insurance policies shall be provided within thirty (30) days.

All insurance issued in compliance with this section shall be insured in the form and by the insurer or insurers satisfactory to and first approved by the CITY in writing. The Contractor shall not allow any subcontractor to commence work on his subcontract until the subcontractor has secured all required bonds and insurance.

ARTICLE 6.10 WORKER'S COMPENSATION INSURANCE: The Contractor shall procure and maintain Worker's Compensation Insurance as required by applicable state or territorial law for all of his employees to be engaged in work at the site of the project under this Contract. In case of any such work sublet, the Contractor shall require the subcontractor similarly to provide Worker's Compensation Insurance for all of the latter's employees to be engaged in such work unless such employees are covered by the protection afforded by the Contractor's Worker's Compensation Insurance. In case any class of employees engaged in hazardous work on the project under this Contract is not protected under the Worker's Compensation Statute, the Contractor shall provide and shall cause each subcontractor to provide adequate employer's liability insurance for the protection of such of his employees as are not otherwise protected.

The Contractor and/or subcontractor shall file a copy of their Certificate of Compensation Insurance with the CITY and no work shall begin until such certificate is filed with the CITY. In the event of cancellation, the insurance company shall give the CITY ten (10) days written notice.

ARTICLE 6.11 SUBCONTRACTING: Attention is directed to the provisions in Section 1-6.2, “Subcontractor Listing”, of the Standard Specifications and these Special Provisions.

In accordance with the requirements of Sections 4100 to 4133 inclusive of the Public Contract Code, each bidder shall list in his Proposal the name and business address of each subcontractor to whom the bidder proposes to subcontract all or a portion of work and shall list each subcontractor licensed by the State of California proposed by the bidder to specially fabricate and install all or a portion of the work. Said list shall include a description of the portion of the work which will be done by each subcontractor.

A sheet for listing the subcontractors as required is included in the proposal. The successful responsible bidder shall submit a letter to the CITY requesting approval of all subcontractors. Included in the letter shall be a list of the names and addresses of each Contractor, items to be subcontracted by item number, brief description of the item, and contract bid value. If only a portion of the item is to be subcontracted, that portion and dollar value of work, based on contract item bid value, shall be indicated.

No subcontractor shall be permitted to perform any work under the contract without having first been approved, in writing, by the CITY.

ARTICLE 6.12 TRESPASS: The Contractor shall be responsible for all damage or injury which may be caused on any property by trespass of the Contractor’s employees in the course of their employment whether the said trespass was committed with or without the consent or knowledge of the Contractor.

ARTICLE 6.13 SAFETY, SANITARY AND MEDICAL REQUIREMENTS: The Contractor, his employees, his subcontractors and their employees shall promptly and fully carry out the existing safety, sanitary and medical requirements as may from time to time be prescribed by the Industrial Safety Commission and by County or State Health Departments to the end that proper work shall be done and the safety and health of the employees and of the community may be conserved and safeguarded. In case any such regulations and orders are not observed by the Contractor, they may be enforced by the Engineer at the Contractor’s expense.

ARTICLE 6.14 WATER AND POWER: Unless otherwise provided in the Special Provisions, the Contractor shall provide, at his own expense, all necessary power required for his operations under the contract.

ARTICLE 6.15 PROTECTION OF UNDERGROUND FACILITIES: Attention is directed to the possible existence of underground facilities not known to the CITY or in a location different from that which is indicated on the plans or in these Special Provisions. The Contractor shall take steps to ascertain the exact location of all underground facilities prior to doing work that may damage such facilities or interfere with their service. If the Contractor discovers underground facilities not indicated on the Plans or in these Special Provisions, he shall immediately give the Engineer written notification of the existence of such facilities. Such facilities shall be protected from damage as

directed by the Engineer and the Contractor will be paid for such work as extra work as provided in Section 7-4 "Payment for Extra Work" of the Standard Specifications.

ARTICLE 6.16 AIR POLLUTION CONTROL: Section 3-12.2, "Air Pollution Control", of the Standard Specifications is supplemented by the following:

The Contractor shall comply with all air pollution control rules, regulations, ordinances and statutes which apply to any work performed pursuant to the contract including any air pollution control rules, regulations, ordinances and statutes specified in Section 11017 of the Government Code.

In the absence of any applicable air pollution control rules, regulations, ordinances or statutes governing solvents, all solvents, including but not limited to the solvent portions of paints, thinners, curing compounds, and liquid asphalt used on the project shall comply with the applicable material requirements of the County Air Pollution Control District. All containers of paint, thinner, curing compound or liquid asphalt shall be labeled to indicate that the contents fully comply with said requirements.

Full compensation for conforming to the requirements in this article shall be considered as included in the price bid for the various contract items of work involved and no additional compensation will be allowed therefor.

ARTICLE 6.17 PROJECT APPEARANCE: The Contractor shall maintain a neat appearance to the work. In any area visible to the public, the following shall apply:

When practicable, broken concrete and debris developed shall be disposed of concurrently with its removal. If stockpiling is necessary the material shall be removed or disposed of on the next working day, except that stockpiles shall not be left in the public right of way on weekends or holidays.

Full compensation for conforming to the requirements in this article shall be considered as included in the prices bid for the various contract items of work involved and no additional compensation will be allowed therefor.

ARTICLE 6.18 FAIR EMPLOYMENT PRACTICE COMMISSION CERTIFICATION: The Contractor's attention is directed to the requirements in Section 12990 of the Government Code for nondiscrimination and compliance employment programs.

ARTICLE 6.19 SOUND CONTROL REQUIREMENTS: The Contractor shall comply with all local sound control and noise level rules, regulations and ordinances which apply to any work performed pursuant to the Contract.

Each internal combustion engine used for any purpose on the job or related to the job shall be equipped with a muffler of a type recommended by the manufacturer. No internal combustion engine shall be operated on the project without said muffler.

The noise level from the Contractor's operations between the hours of 7:30 a.m. and 4:00 p.m. shall not exceed 86 DBA at a distance of 50 feet. This requirement in no way relieves the Contractor from responsibility for complying with local ordinances regulating noise level.

Said noise level requirement shall apply to all equipment on the job or related to the job including, but not limited to, trucks, transit mixers or transient equipment that may or may not be owned by the Contractor. The use of loud sound signals shall be avoided in favor of light warnings except those required by safety laws for the protection of personnel.

Full compensation for conforming to the requirements in this article shall be considered as included in the prices bid for the various contract items of work involved and no additional compensation will be allowed therefor.

ARTICLE 6.20 LEGAL RELATIONS AND RESPONSIBILITY: The Contractor's attention is directed to the provisions of Section 5, "Legal Relations and Responsibilities", of the Standard Specifications and these Special Provisions for the requirements and conditions which he must observe in the execution of the work.

SECTION 7. PROSECUTION AND PROGRESS

ARTICLE 7.01 PROSECUTION AND PROGRESS: The Contractor's attention is directed to Section 6, "Prosecution and Progress of the Work", of the Standard Specifications.

ARTICLE 7.02 TIME LIMIT: The work specified herein and shown on the Plans and Specifications shall be completed within **thirty (30) working days** from the start date specified in the Notice to Proceed. Attention is directed to Section 3-13 and 6-9 of the Standard Specifications for Public Works Construction (The "Greenbook"), "Completion, Acceptance, and Warranty"; and "Liquidated Damages". The CITY shall withhold liquidated damages before the accrual date if the anticipated liquidated damages may exceed the value of the remaining work.

If the total amount of working days have expired and the work is not complete, liquidated damages are five hundred dollars (**\$500.00**) per calendar day.

SECTION 8. PAYMENTS

Within fifteen (15) workdays after the date of acceptance of the work the Engineer will cause to be filed on behalf of the CITY in the Office of the County Recorder a Notice of Completion of the work herein agreed to be done by the Contractor.

Upon expiration of sixty (60) days after the filing of such Notice of Completion of the work, the CITY will pay to the Contractor the amount remaining after deduction from the amount of value stated in the above-mentioned estimate all prior payments to the contract and all amounts to be kept and retained under the provisions of the Contract.

If the Contractor disagrees with the Engineer's final estimate and within said period of sixty (60) days files a written statement of his claims, the Engineer will issue as a semi-final estimate the

proposed estimate submitted to the Contractor and the CITY will within thirty (30) days pay the sum found due thereon after deducting from the amount of value stated in the first mentioned estimate all prior payments to the Contractor and all amounts to be kept and retained under the provisions of the contract. The Engineer will then consider and investigate the Contractor's claim and will make such revision in the said estimate as he may find to be due and will then certify in writing to the City Clerk the whole amount and value of the work done by the Contractor under and according to the terms of the contract. The CITY will pay the amount so found due after deducting all previous payments, amounts to be retained under the contract, and amounts which may be retained in accordance with the applicable specifications.

ARTICLE 8.01 PARTIAL PAYMENTS: At the request of the Contractor, partial payments will be made on a monthly basis. The Progress Pay requests shall be submitted on or before the 20th day of each month. The estimate may include only work completed up to and including this date.

Progress pay requests showing work not accomplished by the 20th day of the month shall be rejected.

ARTICLE 8.02 PAY RETENTION: From each progress estimate **five percent (5%)** will be deducted and retained in accordance with Section 7-3.2 of the Standard Specifications.

ARTICLE 8.03 FINAL ESTIMATE AND PAYMENT: Whenever in the opinion of the Engineer the Contractor shall have completely performed the contract on his part the Contractor shall submit to the Engineer a written statement to the final quantities of contract items for inclusion in the final estimate.

All prior estimates upon which partial payments have been made shall be subject to correction in the final estimate. The final estimate and payments made thereunder shall be final and conclusive upon the Contractor.

ARTICLE 8.04 TAXES: No mention shall be made of sales tax or use tax, as all bid prices submitted shall be considered as including such tax.

SECTION 9. WORK SCHEDULES

ARTICLE 9.01 WORK SCHEDULE: Before the commencement of work, the Contractor shall submit a work schedule prepared using the latest version of Microsoft Project or approved equal to the Engineer for approval. The work schedule shall be submitted at least ten (10) days prior to commencement of work or at the Pre-Construction Meeting, and shall be kept current through the progress of the work. The work shall be performed in order of their priorities and as directed by the Engineer.

The Contractor shall schedule his work so that all excavated locations shall be poured concrete no later than Friday. The Contractor shall not excavate any location that he is not sure that he is able to pour on Friday. No excavated location is allowed over weekends and / or holidays. The Contractor shall pay the sum of five hundred dollars (**\$500.00**) per each calendar day for each excavation left open and not poured concrete over the weekend starting on Saturday or over a holiday for the sidewalk portion of the work.

Full compensation for conforming to the requirements in this article shall be considered as included in the prices bid for the various contract items of work involved and no additional compensation will be allowed therefor.

SECTION 10. CITY REQUIREMENTS

ARTICLE 10.01 FAIR EMPLOYMENT PRACTICES: In connection with the performance of work under this Contract, the Contractor agrees as follows:

1. The Contractor will not willfully discriminate against any employee or applicant for employment because of race, sex, color, religion, age, handicap status, or national origin. The Contractor will take affirmative action to ensure that the applicants are employed, and that employees are treated during employment, without regard to their race, sex, color, religion, age, handicap status, or national origin. Such action shall include, but not be limited to, the following: employment upgrading, demotion or transfer; recruitment or recruitment advertising; layoff or termination; rates of pay or other forms of compensation; and selection for training, including apprenticeship. The Contractor agrees to post in conspicuous places, available to employees and applicants for employment, notices to be provided by awarding authority setting forth the provisions of this fair Employment Practices section.
2. The Contractor will send to each labor union or representative of workers with which he has collective bargaining agreement or other contract or understanding, a notice advising the said labor union workers' representative of the Contractor's commitments under this section, and shall post copies of the notice in conspicuous places available to employees and applications for employment.
3. The Contractor will permit access to his records of employment, employment advertisements, application forms, and other pertinent data and records the Fair Employment Practices Commission, the CITY or any other appropriate agency designated by the CITY for the purposes of investigation to ascertain compliance with the Fair Employment Practices section of this Contract.
4. The finding of willful violation of the Fair Employment practices section of this Contract or of the Fair Employment Practices Act shall be regarded by the CITY as a basis for determining the Contractor to be not a "responsible bidder" as to future contracts for which such Contractor may submit bids.

The CITY shall deem a finding of willful violation of the Fair Employment Practices Act to have occurred upon receipt of written notice from the Fair Employment Practices Commission that it has investigated and determined that the Contractor has violated the Fair Employment Practices Act and has issued an order under Government Code Section 12970 or obtained an injunction under the Government Code Section 12973.

Upon receipt of such written notice from the Fair Employment Practices Commission, the CITY shall notify the Contractor that unless he demonstrates to the satisfaction of

the awarding authority within a stated period that the violation has been corrected, his prequalification rating will be revoked at the expiration of such period.

5. The Contractor agrees, that should the CITY determine that the Contractor has not complied with the Fair Employment Practices section of this Contract, then pursuant to Labor Code Section 1735 and 1755, the Contractor shall, as a penalty to the Agency, forfeit for each calendar day, or portions thereof, for each person who was denied employment as a result of such non-compliance, the penalties provided in the Labor Code for violation of prevailing wage rates. Such monies may be recovered from the Contractor. The Agency may deduct any such damages from any monies due to the Contractor from the Contract.
6.
 - a. Nothing contained in this Fair Employment Practices section shall be construed in any manner or fashion so as to prevent the CITY from pursuing any other remedies that may be available by law.
 - b. Nothing contained in this Fair Employment Practices section shall be construed in any manner or fashion so as to require or permit the hiring of an employee not permitted by the National Labor Relations Act.
7. Prior to award of the Contract, the Contractor shall certify to the awarding authority that he has or will meet the following standards for affirmative compliance which shall be evaluated in each case by the CITY.
 - a. The Contractor shall provide evidence, as required by the CITY, that he has notified all supervisors, foremen and other personnel officers in writing of the content of the anti-discrimination clause and their responsibilities under it.
 - b. The Contractor shall provide evidence, as required by the CITY, that he has notified all sources of employee referrals (including unions, employment agencies, advertisements, Department of Employment) of the content of the anti-discrimination clause.
 - c. Personally, or through his representatives, the Contractor shall, through negotiations with the unions with whom he has agreements, attempt to develop an agreement which will:
 - (1) Spell out responsibilities for non-discrimination in hiring, referral, upgrading and training.
 - (2) Otherwise implement an affirmative anti-discrimination program in terms of the union's specific areas of skill and geography, to the end that qualified minority workers will be available and given an equal opportunity for employment.
 - d. The Contractor shall notify the CITY of opposition to the anti-discrimination clause by individuals, firms or organizations during the period of its prequalification.

8. The Contractor will include the provisions of the foregoing paragraphs 1 through 7 in every first tier subcontract, so that such provisions will be binding upon each such subcontractor.
9. The Contractor, in executing the proposal, thereby certifies that he has or will meet the standards for affirmative compliance with the Fair Employment Practices requirements contained herein.
10. The Contractor shall comply with the procedures and conditions set forth in Section XII of the City of La Habra Affirmative Action Plan as adopted by Resolution 2404 of the City of La Habra January 21, 1975, a portion of which reads as follows:

“It shall be the policy of the City of La Habra to require all contractors and vendors doing business with the CITY in an amount in excess of \$50,000.00 and/or 200 employees to certify their compliance with Title VII of the civil Rights Act and the Equal Employment Opportunity Act of 1972. Said certification shall be stipulated by the CITY to safeguard against discrimination by contractors or vendors on the basis of race, color, creed, sex, age, or nationality concerning the practices of recruitment, promotion, demotion, transfer, layoff, or termination. A violation of this non-discrimination certification will be considered a material provision violation and shall be grounds for termination or suspension, in whole or in part, of the contract by the CITY”.

SECTION 11. CONSTRUCTION DETAILS

ARTICLE 11.01 GENERAL:

Subdivision 11.01.1 Description of Work: The work comprises the furnishing of all materials, equipment, tools, labor and incidentals as required by the Plans, Specifications and Contract Documents for the above stated project. The general items of work to be performed hereunder shall be at various locations throughout the City of La Habra and shall consist of but not be limited to Removal and Reconstruction of PCC Sidewalks, Curbs, Gutters, and Driveway Approaches; Removal and Construction of AC Pavement Slot Trench; Restoring Parkway Irrigation Systems; Regrade Landscape; Install Sod; Root Pruning; Tree Removals; Tree Planting; and all incidental work so indicated on the plans, specifications and tables, and required for the proposed improvements.

Subdivision 11.01.2 Order of Work: Order of work shall conform to the provisions of Section 6-1, “Construction Schedule and Commencement of the Work,” of the Standard Specifications for Public Works Construction (The “Greenbook”) and these Special Provisions.

Subdivision 11.01.3 Public Convenience and Access: The Contractor shall conduct his operations so as to cause minimum obstruction and inconvenience to the public.

At least ten (10) days prior to commencing work, the Contractor shall submit to the Engineer his construction schedule for approval in accordance with Section 9. This schedule shall allow businesses and residents on the affected streets to park within a reasonable distance from their

business or home. The Contractor shall distribute to each resident or business affected by the construction a written notice at least 7 calendar days prior to commencing construction. The Contractor shall notify residents and businesses of the work and post temporary "No Parking" signs. The notice shall include the date and working hours of construction. It shall be the Contractor's responsibility to complete the notification letter with the proper dates at the time of notification. If the Contractor fails to meet the schedule indicated in the Notice, the Contractor shall reschedule his work and re-notify the residents. Request for changes shall be submitted by the Contractor to the Engineer for approval at least 10 working days in advance and residents shall be re-notified 7 calendar days prior to commencing construction.

Continuous emergency and local traffic access shall be maintained in the area of work and vehicular access to individual driveways shall be provided and maintained except for short durations of not more than two hours and with prior notice to the adjacent residents involved. No overnight closure of driveways will be allowed except while construction is in progress and concrete is curing. The Contractor shall provide alternate ramps for access while concrete is curing, where feasible.

Should the Contractor appear to be neglectful or negligent in furnishing warning and protective measures, the Engineer may direct the Contractor's attention to the existence of such hazards. The Contractor shall provide all necessary warning and protective measures immediately, at his expense. Whether the Engineer points out the inadequacy of warning and protective measures or not, such action, or lack of action, on the part of the Engineer shall not relieve the Contractor from the responsibility for public safety or abrogate his obligation to furnish and pay for safety measures and devices. If attention is directed to the existence of a hazard, and the Contractor fails to provide an appropriate remedy, any expense incurred by the CITY for furnishing or maintaining safety measures and devices may be deducted from the pay estimates and the total contract price for the work.

The Contractor shall maintain access for residents at all times during the construction and at the end of each work day as specified above. The travel lanes shall be graded smooth and shall be maintained in a smooth condition throughout the period of construction including weekends, and at times as directed by the Engineer.

The Contractor shall be responsible for maintaining location of, and access to, all utility valves during construction operations.

Subdivision 11.01.4 Public Notice: The Contractor shall notify businesses and residents affected by the construction in writing not less than forty-eight (48) hours in advance of commencement of demolition, construction, or storage of materials in the street. The notice shall include but not be limited to:

1. Time and Date of Commencement.
2. Working Hours of Construction.
3. Date of Completion.
4. Name & Telephone Number of Person to be Contacted, at any hour, in the event of a condition requiring immediate correction.

A copy of the letter shall be submitted to the City Engineer for approval prior to distribution.

The Contractor shall also notify La Habra Police Department, Los Angeles County Fire Department, Trash Hauler, Post Office, Ambulance Service, La Habra City School District Lowell Joint Elementary District, and Fullerton Joint Union High School District about the construction. It shall be the Contractor's responsibility to complete the notification letter, with the proper dates, at the time of notification. If the Contractor fails to meet the schedule indicated in the Notice, the Contractor shall reschedule his work and re-notify all those listed above.

Subdivision 11.01.5 Hours of Work: All work shall be performed between 7:30 A.M. and 4:00 P.M., Mondays through Fridays except holidays. No work shall be performed outside normal working hours without advanced authorization from the Engineer. If work is adjacent to a school or on a major arterial including Idaho Street and La Habra Boulevard, working hours will be restricted to 9:00 A.M. to 3:00 P.M., Mondays through Fridays except holidays. For any inspection outside of regular working hours, the Contractor shall pay all costs for the inspector's time. Request for overtime inspection shall be made in writing to the Engineer.

Full compensation for conforming to the requirements in this article shall be considered as included in the prices bid for the various contract items of work involved and no additional compensation will be allowed therefor.

ARTICLE 11.02 FURNISH AND APPLY WATER: Should the Contractor require water for construction operations, such as for compaction and dust control, he may use water from any fire hydrant adjacent to the job site upon application of a "No Fee" permit from the CITY, Engineering Department. The Contractor shall apply water for dust control as necessary and as directed by the Engineer.

Prior to using water, the Contractor shall install a water meter, a valve and an approved back-flow prevention device on the fire hydrant at his expense. The Contractor shall notify Los Angeles County Fire Department and the Public Works Department twenty-four (24) hours in advance, stating the location of the hydrant and the hours when it will be used. The Contractor shall operate the fire hydrant with a hydrant wrench only. Should damage occur to the hydrant, the Contractor shall make repairs at his expense and/or further use of CITY Water may be prohibited. The meter will be used for monitoring water use only. The Contractor will not be charged for water used on the project.

Full compensation for conforming to the requirements in this article shall be considered as included in the prices bid for the various contract items of work involved and no additional compensation will be allowed therefor.

ARTICLE 11.03 DUST CONTROL: The Contractor shall at all times, including weekends, at his expense, control dust on the project. Should the Contractor fail to maintain adequate dust control, the CITY will maintain the site, and an amount equal to twice the actual cost shall be assessed to the Contractor.

Full compensation for conforming to the requirements in this article shall be considered as included in the prices bid for the various contract items of work involved and no additional compensation will be allowed therefor.

ARTICLE 11.04 EXCESS EXCAVATED MATERIAL: Excess excavated material shall be removed from the site and disposed of by the Contractor at his own expense. Excavated material including base, rock and subgrade soils, shall be removed from the job site at the end of the workday. Failure to do so will result in the CITY removing material at the Contractor's expense. Cost shall be calculated at actual cost for labor and equipment plus overhead and benefits plus 125 percent administrative charges.

Full compensation for conforming to the requirements in this article shall be considered as included in the prices bid for the various contract items of work involved and no additional compensation will be allowed therefor.

ARTICLE 11.05 STORAGE OF MATERIALS: The Contractor shall at all times carefully and properly protect all materials of every description both before and after being used in the work and provide any enclosing or special protection from the weather as deemed necessary by the Engineer.

Full compensation for conforming to the requirements in this article shall be considered as included in the prices bid for the various contract items of work involved and no additional compensation will be allowed therefor.

ARTICLE 11.06 SOLID WASTE COLLECTION: If collection of solid waste shall occur during street construction, the Contractor shall assist the solid waste collection contractor in accessing containers for his collection of solid waste.

Full compensation for conforming to the requirements in this article shall be considered as included in the prices bid for the various contract items of work involved and no additional compensation will be allowed therefor.

ARTICLE 11.07 APPURTENANT WORK: All items in the proposal form are considered as complete in place including all incidental and appurtenant work and materials necessary for the satisfactory completion of the same.

Full compensation for conforming to the requirements in this article shall be considered as included in the prices bid for the various contract items of work involved and no additional compensation will be allowed therefor.

ARTICLE 11.08 STORAGE YARD: The Contractor shall at his expense provide a storage yard for his equipment, tools, and materials to be stored. Location of storage yard shall be approved by the Engineer. CITY streets are not to be used as a storage area/yard.

Full compensation for conforming to the requirements in this article shall be considered as included in the prices bid for the various contract items of work involved and no additional compensation will be allowed therefor.

ARTICLE 11.09 PUBLIC UTILITIES: It is the Contractor’s responsibility to notify Underground Service Alert (USA) to locate facilities prior to beginning the work. In addition, the Contractor shall locate service laterals that may be affected by the work and take measures to protect all utilities and service laterals in the streets and parkways.

The Contractor shall determine for himself the exact location of all public and private utilities, facilities or substructures, which are not shown on the plans. In the event any utility, facility or substructure is disturbed or damaged, whether in its original or relocated position, the Contractor shall immediately cause repairs to be made to the satisfaction of the owner at no cost to the CITY.

The Contractor shall notify the utility companies at least forty-eight (48) hours prior to construction.

AT&T	YVETTE GAROFANO	(714) 618-9146
CALIFORNIA DOMESTIC WATER COMPANY	CHE VENEGAS	(562) 947-3811
CHEVRON USA	DAVE ZERLER	(310) 669-4014
CITY OF LA HABRA PARKS DEPT	DAVID VILLALBA	(562) 383-4170
CITY OF LA HABRA SEWER AND WATER DEPT	BRIAN JONES	(562) 383-4170
COMCAST CABLE COMPANY		(800) 501-5738
CRIMSON PIPELINE	APRIL HARVEY	(562) 285-4195
CR&R (WASTE HAULER)		(714) 372-8209
FRONTIER COMMUNICATIONS	ARIEL FATALA	(714) 375-6717
KINDER MORGAN	DON QUINN	(714) 560-4400
LA HABRA HEIGHTS WATER COMPANY		(562) 697-6769
METROPOLITAN WATER DISTRICT	MATT PARRY	(714) 577-5084
MOBIL OIL	RUTH CRONIN-FRUITT	(310) 212-1761
ORANGE COUNTY SANITATION DISTRICT	DANIEL LEE	(714) 593-7176
PLAINS ALL AMERICAN PIPELINE	JOE MATTEO	(562) 728-2368
SO CAL EDISON	JIMMY PARKIN	(714) 578-3434
SO CAL GAS	JASON MORTON	(213) 312-5735
SHELL PIPE COMPANY	MALDONADO	(310) 816-2063
SPECTRUM	PARKER YEE	(562) 677-0213
SUBURBAN WATER SYSTEMS	JAMES CHO	(626) 543-2548
TORRANCE LOGISTICS COMPANY	TERI A. SHINDE	(310) 212-1794
UNOCAL	ARNA ADAMS	(213) 864-5663
WESCON C/O VINTAGE PRODUCTION	EMILIO RODRIGUEZ	(562) 665-9255
UNDERGROUND SERVICE ALERT		(800) 422-4133

Full compensation for conforming to the requirements in this article shall be considered as included in the prices bid for the various contract items of work involved and no additional compensation will be allowed therefor.

ARTICLE 11.10 RESTORATION OF IMPROVEMENTS: Improvements disturbed by the Contractor shall be restored to its original condition or better as follows:

Lawn Areas: Lawn areas disturbed by the construction area shall be graded smooth and level with the adjacent lawn. All dirt clumps greater than one inch in size shall be crumbled or removed and all stone or rock shall be removed. The disturbed area shall be replaced with sod of a variety similar to the adjacent lawn. Shrubs destroyed or removed shall be replaced in kind to the satisfaction of the adjacent property owner. Paved areas shall be restored in kind to the satisfaction of the adjacent property owner. All fences disturbed, damaged or removed shall be restored to the satisfaction of the Engineer. In areas of close quarters the Contractor shall excavate by hand. Facilities damaged by using power tools shall be replaced to the satisfaction of the adjacent property owner. Cement concrete sidewalks removed or damaged shall be saw-cut and removed to the nearest score mark and replaced in accordance with SPPWC Detail 112-2. Any other improvements disturbed shall be restored to its original conditions and to the satisfaction of the adjacent property owner. Sprinklers and irrigation lines disturbed by the construction operations shall be restored to their original condition or better to the satisfaction of the adjacent property owner and/or Engineer.

Full compensation for conforming to the requirements in this article shall be considered as included in the prices bid for the various contract items of work involved and no additional compensation will be allowed therefor.

ARTICLE 11.11 WASTE MANAGEMENT: The Contractor shall comply with the requirements of AB939 and City of La Habra Construction and Demolition Ordinance, and submit a Waste Management Plan for the approval of the Engineer.

Full compensation for conforming to the requirements in this article shall be considered as included in the prices bid for the various contract items of work involved and no additional compensation will be allowed therefor.

ARTICLE 11.12 PUBLIC CONVENIENCE & SAFETY: At least ten (10) working days prior to commencing work, the Contractor shall submit its construction schedule to the Agency for approval. This schedule shall allow residents on the streets to park within a reasonable distance from their homes. Based upon the construction schedule, the Contractor shall notify residents and businesses forty-eight (48) hours prior to the commencement of work and post temporary "No Parking" signs. Requests for changes in the schedule shall be submitted by the Contractor to the Engineer for approval at least five (5) business days prior to the commencement of work.

The Contractor shall be responsible for adequate barricading of the work area and controlling of traffic in the vicinity of the project as specified in Section 5-7 "Safety" in the Standard Specifications or as directed by the Engineer.

Closures and parking restrictions shall only be made for the amount of time necessary to complete construction activities. Areas that do not have active construction work shall be secured and reopened as directed by the Engineer. Extents of closures and parking restrictions shall be limited to areas as necessary for immediate construction activities.

The Contractor's operations shall cause no unnecessary inconvenience. The access rights of the public shall be considered at all times. Unless otherwise authorized, traffic shall be permitted to pass through the Work, or an approved detour shall be provided.

Safe and adequate pedestrian and vehicular access shall be provided and maintained to: fire hydrants; commercial and industrial establishments; churches, schools, and parking lots; service stations and motels; hospitals; police and fire stations; and establishments of similar nature. Access to these facilities shall be continuous and unobstructed unless otherwise approved by the Engineer.

Safe and adequate pedestrian zones and public transportation stops, as well as pedestrian crossings of the Work at intervals not exceeding 300 feet in each direction, shall be maintained unless otherwise approved by the Engineer. Contractor shall not disturb two consecutive transportation stops.

Vehicular access to residential driveways shall be maintained to the property line except when necessary construction precludes such access for reasonable periods of time. If backfill has been completed to the extent that safe access may be provided, and the street is opened to local traffic, the Contractor shall immediately clear the street and driveways and provide and maintain access.

The Contractor shall cooperate with the various parties involved in the delivery of mail and the collection and removal of trash and garbage to maintain existing schedules for these services.

Full compensation for conforming to the requirements in this article shall be considered as included in the prices bid for the various contract items of work involved and no additional compensation will be allowed therefor.

ARTICLE 11.13 BID SCHEDULE: The quantities and sizes of materials shown in the bid schedule are for bid purposes only. The actual quantities used for construction and payment purposes shall be measured and determined by the CITY.

ARTICLE 11.14 EARTHWORK: Earthwork shall conform to the requirements of Section 300, "Earthwork" of the Standard Specifications and shall include all clearing and grubbing, demolition, saw-cut, excavation, grading, removal, disposal, backfilling or any other work necessary to prepare the sub-grade for construction of improvements.

Subdivision 11.14.1 Clearing and Grubbing: Clearing and grubbing shall conform to the applicable portions of Section 300, "Earthwork" of the Standard Specifications. All PCC and asphalt concrete to be removed shall be sawcut as needed to provide straight clean joints.

The tasks included as part of clearing and grubbing include the following:

1. Removal and restoration, replacement or relocation of fences, planters, foundations, walls, vegetation and irrigations systems not included as part of other bid items.
2. Protection of existing utilities, trees, fences, walls, signs and other facilities within the construction zone, except those directed to be removed or relocated.

Full compensation for conforming to the requirements in this article shall be considered as included in the prices bid for the various contract items of work involved and no additional compensation will be allowed therefor.

ARTICLE 11.15 TRENCHING: (Public Contracts Code §7104) If the herein public works contract involves digging trenches or other excavations that extend deeper than four feet below the surface the Contractor shall promptly, and before the following conditions are disturbed, notify the local public entity, in writing, of any:

- (1) Material that the Contractor believes may be material that is hazardous waste, as defined in Section 25117 of the Health and Safety Code, that is required to be removed to a Class I, Class II, or Class III disposal site in accordance with provisions of existing law.
- (2) Subsurface or latent physical conditions at the site differing from those indicated by information about the site made available to bidders prior to the deadline for submitting bids.
- (3) Unknown physical conditions at the site of any unusual nature, different materially from those ordinarily encountered and generally recognized as inherent in work of the character provided for in the contract.
- (4) The CITY shall promptly investigate the conditions, and if it finds that the conditions do materially so differ, or do involve hazardous waste, and cause a decrease or increase in the Contractor's cost of, or the time required for, performance of any part of the work shall issue a change order under the procedures described in the contract.
- (5) That in the event that a dispute arises between the CITY and the Contractor whether the conditions materially differ, or involve hazardous waste, or cause a decrease or increase in the Contractor's cost of, or time required for, performance of any part of the work, the Contractor shall not be excused from any scheduled completion date provided for by the contract, but shall proceed with all work to be performed under the contract. The Contractor shall retain any and all rights provided either by contract (Section 6.01.6 of the herein Special Provisions) or by law which pertain to the resolution of disputes and protests between the contracting parties.

ARTICLE 11.16 ROOT PRUNING: In some locations, there may be tree roots that need to be removed for proper construction of the improvements. In these cases, the Contractor, at his own expenses, shall cut, remove, and properly dispose the roots per Engineer instructions and per all applicable laws, rules and regulations. All work necessary to remove and properly dispose of all removed material shall be at no extra cost to the CITY.

Payment for root pruning/shaving within the limits of the street, curbs, sidewalks, or drive approaches shall be included in the prices paid for the various contract items of work listed in the Bid Schedule, and no additional compensation will be allowed therefor.

These pruning guidelines shall be followed by all persons or firms repairing or replacing damaged street, curbs, sidewalks, driveways or access ramps where the damage is attributable to the roots of the trees growing in the public right-of-way.

One of the following methods or a combination of methods shall be used when pruning or root removal of tree roots:

Whenever possible, root pruning should only be performed on one side of a tree at a time, meaning on the sidewalk side or street side, but not on both, unless specifically authorized by an International Society of Arboriculture (I.S.A.), Certified Arborist. The Certified Arborist shall be in good standing with the I.S.A.

- a. Root Pruning: The actual pruning of roots should be done using a trenching machine, which operates in a vertical motion only, with a root pruning attachment or some comparable piece of equipment, which can safely cut a narrow trench four (4) to six (6) inches wide.
- b. Selective Root Removal: Root larger than three (3) inches in diameter shall be horizontally trimmed or selectively removed. The utilization of a chain saw or other sawing tool shall be employed during this procedure. This procedure shall be overseen by an I.S.A. Certified Arborist at the Contractor's expense. Certified Arborist cost shall be included in the prices paid for the various contract items of work listed in the Bid Schedule, and no additional compensation will be allowed therefor.

All tree activity shall be conducted in a manner specified by ANSI Z133.1 – 2006 Safety Requirements & ANSI A300 (Part 1)-2001 Standard Practices (Pruning).

If the report from the Certified Arborist recommends the tree be removed because necessary root pruning would be detrimental to the structural integrity of the tree, the Contractor will coordinate with the CITY for removal by CITY resources.

ARTICLE 11.17: CONSTRUCTION STAKING AND MONUMENT PERPETUATION: The Contractor shall provide all labor, tools, work, materials and appurtenances necessary to survey the work to conform to plan lines and limits, provide grades for drainage, establish pavement grades, match to existing conditions, and otherwise lay out the work as necessary for construction. The Contractor shall review and set all reference points, grades and elevations to the satisfaction of the Engineer prior to construction operations.

Pavement shall be replaced to match existing conditions. Grades shall provide for adequate drainage, match to existing slopes, gutters and other improvements, and provide a smooth profile.

Prior to the start of construction, the Contractor's licensed Land Surveyor or registered Civil Engineer licensed to practice land surveying in the State of California shall, in conformance with California State Law AB 1414, locate all monuments (whether or not of record), bench marks, and centerline ties within the construction zone, i.e., within one hundred feet of the construction activity. Additional ties to monuments shall be set when ties are missing (min. 4 ties per monument.) The Contractor's surveyor or qualified Civil Engineer shall prepare and submit for review to the Engineer separate tie sheets and Corner Record sheets (monuments not of record shall have only tie sheets prepared). Tie sheets and Corner Records shall conform to the County Standards and the County Engineers' Association of California's "Guide to the Preparation of Records of Survey and Corner

Records” document as provided by the County of Orange Land Surveyor’s Office. Upon review by the Engineer, the Land Surveyor shall file the Corner Records with the County of Orange Land Surveyor’s Office as required by law, and file Certified Corner Records with the City Engineer.

After construction and prior to final acceptance by the CITY of the construction project, the Contractor’s land surveyor or qualified Civil Engineer shall re-survey all field monuments and centerline ties within the construction zone, prepare tie sheets and Corner Record sheets as indicated above, and file them with the City Engineer for review. After review by the City Engineer, the land surveyor shall file the Corner Records with the County of Orange Land Surveyor’s Office as required by law, and file certified copies of the Corner Records with the City Engineer.

The Contractor shall not disturb any monuments, stakes or sign posts found on the line of the improvement until authorized by the Engineer. The Contractor shall bear the expense of resetting any monument, stakes or sign posts which may be disturbed without authorization from the Engineer. All survey monuments removed or altered as a result of construction shall be reset, Corner Records filed with the County of Orange Land Surveyor’s Office, and approved final Corner Records filed with the City Engineer. Centerline ties removed as a result of construction shall be reset and tie sheets filed with the City Engineer.

The Contractor is responsible to re-establish any survey monument that is disturbed, including monuments at the property line with no extra cost to the CITY to the satisfaction of the City Engineer.

The land surveyor shall provide a letter of certification for all monuments having four or more existing ties which are within 0.02 feet plus or minus of the original CITY tie sheet records. When several monuments or ties appear on one tie sheet and one of the ties has changed, the land surveyor shall re-measure all of the ties and re-file a new tie sheet with the CITY as required herein.

County of Orange permanent and temporary bench marks within the construction zone shall be located by survey, and the Contractor’s Land Surveyor shall send a written notification of impending construction to the County of Orange Land Surveyor’s Office two weeks prior to construction.

Lines and grades for the construction shall be the responsibility of the Contractor, with the following provisions:

All work under this contract shall be built in accordance with the lines and grades shown on the plans. Field survey for establishing these, and for the control of construction, shall be the responsibility of the Contractor. All such survey work including construction staking shall be done under the supervision of a California Licensed Land Surveyor or authorized Civil Engineer. Staking shall be done on all items ordinarily requiring grade and alignment, at intervals normally accepted by the agencies and trade involved.

The Contractor shall provide a copy of the office calculations and grade sheets to the Engineer. The Contractor shall be responsible for any errors in the finished work, and shall notify the Engineer, in writing, within twenty-four (24) hours, of any discrepancies, or design errors during the construction staking.

Contractor shall provide construction surveying for relocation of any conflicting utilities and provide a reasonable time window of opportunity to the utility owners to relocate their facilities after the survey is provided by the Contractor.

Project retention will not be released until all records are recorded with the County of Orange Land Surveyor's Office.

Full compensation for conforming to the requirements in this article shall be considered as included in the contract bid prices for the various contract items of work involved and no additional compensation will be allowed thereof.

SECTION 12: BID ITEMS FOR ANNUAL SIDEWALK IMPROVEMENT PROJECT FY 24-25:

(BID ITEM 1) ARTICLE 12.01: MOBILIZATION (Not to exceed Five Percent (5%) of the total bid amount): Mobilization shall include all labor, work, and materials necessary to mobilize and demobilize forces, equipment, and materials; obtain bonding, insurance, permits, licenses; and other work as necessary to prepare for the construction of the work. Compensation for Mobilization shall not exceed **Five Percent (5%)** of the total bid amount for BID SCHEDULE.

Full compensation for complying with the work contained in this article for **MOBILIZATION (BID ITEM 1)** shall be considered included in the contract bid price per Lump Sum (LS), and no additional compensation will be allowed therefor. One half of the bid amount shall be paid upon beginning work and completion of at least ten percent (10%) of the other bid items. One half shall be paid upon completion of the work, punch-list items, and complete cleanup and restoration of the project site.

(BID ITEM 2) ARTICLE 12.02: STORM WATER BEST MANAGEMENT PRACTICES (BMPs): The Contractor shall comply with Section 3-12 "Work Site Maintenance" of the Standard Specifications for Public Works Construction. The Contractor shall not permit polluted water to enter a catch basin or drainage channel. Water pollution control work shall consist of constructing those facilities which may be shown on the Plans, specified elsewhere in these Special Provisions, required by the Standard Specifications, required by National Pollutant Discharge Elimination System (NPDES No. CAS000002) California General Permit for Storm Water Discharges Associated with Construction and Land Disturbance Activities Order No. 2009-0009-DWQ, or ordered by the Engineer. Said work is intended to provide prevention, control and abatement of water pollution to streams, waterways and other bodies of water.

In order to provide effective and continuous control of water pollution, it may be necessary for the Contractor to perform the contract work in small or multiple units on an out-of-phase schedule and with modified construction procedures. The Contractor shall provide temporary pollution control measures including, but not limited to, dikes, basins, ditches and the application of straw and seed which become necessary as a result of his operations. The Contractor shall coordinate water and pollution control work with all other work done on the contract.

Before starting any work on the project, the Contractor shall submit to the Engineer for acceptance a Water Pollution Control Plan (WPCP) for effective control of water pollution. Such WPCP shall show the schedule for the erosion control work included in the contract and for all water pollution control measures which the Contractor proposes to take in connection with construction of the project to minimize the effect of his operations upon adjacent streams and other bodies of water. The Contractor shall not perform any clearing and grubbing, or earthwork on the project, other than that specifically authorized in writing by the Engineer, until such WPCP has been accepted. The Contractor shall revise and bring up to date said WPCP at any time the Engineer makes written request for such revision.

The Engineer will notify the Contractor of the acceptance or rejection of any submitted or revised WPCP in not more than ten (10) days.

The CITY shall not be liable to the Contractor for failure to accept all or any portion of an originally submitted or revised WPCP, nor for any delays to the work due to the Contractor's failure to submit an acceptable WPCP.

The Contractor may request the Engineer to waive the requirement for submission of a written WPCP for control of water pollution when the nature of the Contractor's operation is such that erosion is not likely to occur. Waiver of this requirement will not relieve the Contractor from responsibility for compliance with the other provisions of this section. Waiver of the requirement for a written WPCP for control of water pollution will not preclude submittal of a written WPCP at a later time if the Engineer deems it necessary because of the effect of the Contractor's operations.

Where erosion control damage will cause water pollution which is probably due to the nature of the material or the season of the year, the Contractor's operations shall be so scheduled that permanent erosion control features will be installed concurrently with or immediately following grading operations.

Compliance with the requirements of this article shall in no way relieve the Contractor from his responsibility to comply with the other provisions of the Contract, in particular, his responsibility for damage and for preservation of property.

All water pollution control work performed in accordance with the accepted WPCP which is not otherwise required under the contract and which is ordered by the Engineer will be paid for as follows:

- (1) Such water pollution control work which may be accomplished under the various contract items of work will be measured and paid for as provided for in these Special Provisions for the said items of work.
- (2) Such water pollution control work not covered by contract items will be paid for as extra work as provided for in Section 7-4 "Payment for Extra Work" of the Standard Specifications.

Except as otherwise provided in this Article 12.02, or in the Standard Specifications or elsewhere in these Special Provisions, full compensation for complying with the work contained in this article for STORM WATER BEST MANAGEMENT PRACTICES (BMPs) (BID ITEM 2) shall be considered included in the contract bid price per Lump Sum (LS), and no additional compensation will be allowed therefor.

(BID ITEM 3) ARTICLE 12.03: TRAFFIC CONTROL, SAFETY, AND CLEANUP (Not to exceed Five Percent (5%) of the total bid amount): Prior to construction, the Contractor shall submit to the Engineer for approval, a traffic control plan. This plan shall include, but not be limited to, location of all signs and barriers and proposed traffic flow diagrams. The information shall include the minimum requirements of W.A.T.C.H., latest edition. **An approved Traffic Control Plan (TCP) will be required for locations on major arterials including Idaho Street and La Habra Boulevard.** The TCP shall be signed and stamped by either a Traffic Engineer (T.E.) or Professional Civil Engineer (P.E.), registered in the State of California and submitted by the Contractor to the CITY for approval. Compensation for Traffic Control, Safety, and Cleanup shall not exceed **Five Percent (5%)** of the total bid amount for BID SCHEDULE.

The Contractor shall furnish at his expense and with no extra cost to the CITY, flagmen and guards as are necessary to give adequate warning to the public that roadway work is underway and of any dangerous conditions to be encountered. Flagmen shall perform their duties and be provided with equipment in accordance with current "Instructions to Flagmen" of the State of California, Division of Highways.

The equipment shall be furnished, kept clean and in good repair by the Contractor at his own expense. The Contractor shall furnish, erect, maintain and regularly inspect barricades, lights, signs and other devices as are necessary to prevent accidents and avoid damage or injury to the public. These devices shall conform to the requirements set forth in the current "Manual of Warning Signs, Lights and Devices for Use in Performance of Work Upon Highways", issued by the State of California, Department of Transportation.

Traffic maintenance shall conform to the provisions in Section 5-7 "Safety" of the Standard Specifications and these Special Provisions or as directed by the Engineer.

The Contractor shall maintain complete liability and responsibility for implementing project site cleanliness, traffic control, and safety at all times. If, in the opinion of the Engineer or his designated representative, there is a condition warranting corrective action by the Contractor, the Contractor will be advised and requested to correct the condition to the satisfaction of the Engineer. This requirement in no way absolves the Contractor of any obligation or duty to provide for the safety of persons and property at all times, nor does it impose any obligation or duty on the Engineer to provide any such services or advisement.

In the event that the Contractor does not immediately respond to the Engineer's request for corrective action, and the situation presents a hazard to persons and/or property, the Engineer may cause the work to be corrected by others. Likewise, in the event that the Contractor is not on site, cannot immediately respond, or is otherwise unavailable, the Engineer may cause the work to be corrected by others. If corrective work is performed by others, then the Contractor may be charged for all of

the costs, including overhead and indirect costs, required to correct the work. Inspector's costs shall be per Article 4.06 INSPECTION. Engineer's costs shall be 1.5 times the noted Inspector's rate. In addition, the Engineer may impose additional penalties as provided for elsewhere in these specifications.

The Contractor's supervisor in the field will not leave the project site until he has personally inspected and verified that all cleanliness, traffic control, and safety conditions are in a suitable condition. Likewise, no work may commence at the beginning of the work day until all cleanliness, traffic control, and safety measures and procedures have been reviewed, discussed, and implemented by the Contractor's supervisor with all of the contractor's and subcontractor's forces.

Full compensation for conforming to the requirements in this article TRAFFIC CONTROL, SAFETY, AND CLEANUP (BID ITEM 3) shall be considered as included in the contract bid price per Lump Sum (LS), and shall include all labor, tools, materials and appurtenances necessary to complete the work and no additional compensation will be allowed therefor.

(BID ITEM NO. 4) ARTICLE 12.04: REMOVE AND RECONSTRUCT 4" THICK CONCRETE SIDEWALK PER SPPWC DETAIL 112-2: This bid item shall include all labor, tools, materials, and appurtenances necessary to remove existing and reconstruct new 4" thick concrete sidewalks per the SPWWC DETAIL 112-2, complete in place. Portland cement concrete material shall be Portland Cement Concrete of type 520-C-2500. The Contractor shall saw-cut, excavate, and remove existing in-place materials as necessary for construction. Following removal, the subgrade shall be prepared and compacted to a minimum of 90% relative compaction, as determined by ASTM D1557, to ensure a stable and uniform base for the new sidewalk. This includes any necessary backfill with approved granular material, and compacted to the specified density. Fine grading of the subgrade will be performed to achieve the required elevations and slopes for proper drainage. After subgrade preparation, the Contractor shall construct the new concrete sidewalk. Included in this item is the enlargement of tree wells, to be paid per square foot of removed sidewalk. Proper disposal of all removed materials is required. Limits of construction shall be verified, measured, and marked in the field by the Engineer prior to removing existing improvements.

Sidewalks shall meet all ADA requirements and shall not create impediments to access. Sidewalk features, per standard plan, shall include:

- Cross-slope not exceeding 1.5% slope
- Running slope not exceeding 4.5% slope

The Contractor shall replace/restore and repair irrigation system damaged or affected by his operation at all locations.

Full compensation for conforming to the requirements in this article REMOVE AND RECONSTRUCT 4" THICK CONCRETE SIDEWALK PER SPPWC DETAIL 112-2 (BID ITEM 4) shall be considered as included in the contract bid price per Square Foot (SF), and shall include all labor, tools, materials and appurtenances necessary to complete the work and no additional compensation will be allowed thereof.

(BID ITEM NO. 5) ARTICLE 12.05: REMOVE AND RECONSTRUCT 6" THICK CONCRETE DRIVEWAY APPROACH PER SPPWC DETAIL 110-2, WITH 1 FT. AC SLOT: This bid item shall include all labor, tools, materials and appurtenances necessary to remove existing and construct new 6" thick concrete driveway per SPPWC DETAIL 110-2 (as indicated in Appendix B) with 1 ft. AC slot patch complete in place. The Contractor shall saw-cut, excavate and remove existing in-place materials as necessary and properly dispose of material, grade and compact subgrade to a minimum of 95% relative compaction; and construct new driveway approach. The Contractor shall construct an asphalt concrete slot twelve inches wide with length that matches the length of the new driveway approach. Adjustment of any existing pipe openings shall be included in the contract bid price. Limits of construction shall be verified, measured and marked in the field by the Engineer prior to removing existing improvements.

Portland cement concrete material shall be Portland Cement Concrete of Type 520-C-2500. Slot Patch should be Type C2 PG 64-10.

AC slot patch shall also be required on backside of driveway where driveway adjoins asphalt parking lot.

The Contractor shall replace/restore and repair irrigation system damaged or affected by his operation in all locations.

No open excavations will be allowed over a weekend or holiday. The Contractor shall schedule work to accommodate this requirement. All concrete must be in place and forms removed prior to weekends and holidays.

Any businesses shall have driveway plated and be provided continuous access to their parking lot.

Parking lot striping affected by the work shall be replaced in kind with two coats of water based paint a minimum of 7 days apart between coats and with glass beads. Striping of parking lot is considered included in this bid item and no additional compensation will be allowed.

Payment for curb and gutter within the limits of the driveway approach shall be included in the contract bid price. Contractor shall pour curb and gutter non-monolithic from driveway.

Full compensation for conforming to the requirements in this article **REMOVE AND RECONSTRUCT 6" THICK CONCRETE DRIVEWAY APPROACH PER SPPWC DETAIL 110-2, WITH 1 FT. AC SLOT (BID ITEM 5)** shall be considered as included in the contract bid price per Square Foot (SF), and shall include all labor, tools, materials and appurtenances necessary to complete the work and no additional compensation will be allowed thereof.

(BID ITEM NO. 6) ARTICLE 12.06: REMOVE AND RECONSTRUCT VARIABLE HEIGHT CONCRETE CURB AND GUTTER OVER 6" CMB PER SPPWC DETAIL 120-3, WITH 1 FT. AC SLOT: This bid item shall include all labor, materials, equipment, and work necessary to remove existing and construct new variable height concrete curb and gutter over 6" CMB per SPPWC detail 120-3 with 1 ft. AC slot patch complete in place. The Contractor shall saw-cut; excavate and remove existing in-place materials as necessary and properly dispose of materials, grade and compact subgrade; and construct new variable height curb and gutter. Limits of construction shall be verified,

measured and marked in the field by the Engineer prior to removing existing improvements. The Contractor shall construct an asphalt concrete slot twelve inches wide with length that matches the length of the new curb and gutter. Adjustment of any existing pipe openings shall be included in the contract bid price. Curb and gutter shall be poured non-monolithic with sidewalk at locations where new sidewalk would adjoin new curb and gutter.

Portland cement concrete material shall be Portland Cement Concrete of Type 520-C-2500. Slot Patch should be Type C2 PG 64-10.

The Contractor shall replace/restore and repair irrigation system damaged or affected by his operation in all locations.

The Contractor shall repaint the address of any house that is affected by the curb and gutter replacement at no extra cost to CITY to the satisfaction of the Engineer.

No open excavations will be allowed over a weekend or holiday. The Contractor shall schedule work to accommodate this requirement. All concrete must be in place and forms removed prior to weekends and holidays.

Full compensation for conforming to the requirements in this article VARIABLE HEIGHT CONCRETE CURB AND GUTTER OVER 6" CMB PER SPPWC DETAIL 120-3, WITH 1 FT. AC SLOT (BID ITEM 6) shall be considered as included in the contract bid price per Linear Foot (LF), and shall include all labor, tools, materials and appurtenances necessary to complete the work and no additional compensation will be allowed thereof.

(BID ITEM NO. 7) ARTICLE 12.07: REMOVE VARIOUS DIAMETER STREET TREE: This bid item shall include the removal of street trees ranging from twelve-inch diameter to twenty-four-inch diameter, removal of stumps, removal of roots, removal of stump grindings, backfill with clean dirt, grading, compaction, repair of affected working irrigation, and re-establishment of existing landscaping.

Full compensation for conforming to the requirements in this article REMOVE VARIOUS DIAMETER STREET TREES (BID ITEM 7) shall be considered as included in the contractor bid price per each (EA), and shall include all labor, tools, equipment, materials, and appurtenances necessary to complete the work and no additional compensation will be allowed thereof.

(BID ITEM NO. 8) ARTICLE 12.11: PLANT AND STAKE 24 IN. BOX STREET TREE AND INSTALL ROOT BARRIERS PER SPPWC DETAILS 518-4 AND 520-5: This bid item shall include the planting and staking of 24" box street trees, to include install of root barrier (18 in. x 12 ft.), water and maintain street trees until the project punch list of completed. Tree species and planting location to be selected by the City Engineer. The street trees are to be planted at, or near locations where street trees were removed.

Full compensation for conforming to the requirements in this article PLANT AND STAKE 24 IN. BOX STREET TREE AND INSTALL ROOT BARRIERS PER SPPWC DETAILS 518-4 AND 520-5 (BID ITEM 8) shall be considered as included in the contractor bid price per each (EA), and

shall include all labor, tools, equipment, materials, and appurtenances necessary to complete the work and no additional compensation will be allowed thereof.

(BID ITEM NO. 9) ARTICLE 12.13: REMOVE AND RECONSTRUCT CONCRETE WALKWAY WITH DETECTABLE WARNING SURFACE AND 1 FT. AC SLOT: This bid shall include all labor, tools, materials and appurtenances necessary to remove existing and construct new concrete walkway with detectable warning surface over compacted native soil, and 1 ft. AC slot patch complete in place. The Contractor shall saw-cut, excavate and remove existing in-place materials as necessary and provide proper disposal of material, compact subgrade, and construct new 4” concrete walkway with detectable warning surface and 1 ft. AC slot. The Contractor shall construct an asphalt concrete slot twelve inches wide with length that matches the length of the new concrete walkway with detectable warning surface. Limits of construction shall be verified, measured and marked in the field by the Engineer prior to removing existing improvements.

Detectable warning surface shall conform to the standard plans and shall be precast tactile tiles by Armor-Tile Cast in place or approved equal, 4’x3’ minimum. The color of the detectable warning surface shall be YELLOW unless otherwise specified. Length of Armor-Tile Cast to be installed adjacent to building is 55’x3’.

The Contractor shall submit to the Engineer for review the following items:

- A. Product Data: Submit manufacturer’s literature describing products, installation procedures and routine maintenance.
- B. Samples: Submit two tile samples of the kind proposed for use (minimum size 6” by 8”).

Full compensation for conforming to the requirements in this article **REMOVE AND RECONSTRUCT CONCRETE WALKWAY WITH DETECTABLE WARNING SURFACE AND 1 FT. AC SLOT (BID ITEM 9)** shall be considered as included in the contractor bid price per each (SF), and shall include all labor, tools, equipment, materials, and appurtenances necessary to complete the work and no additional compensation will be allowed thereof.

SECTION D

PROPOSAL

PROPOSAL

City of La Habra
Civic Center
110 E. La Habra Blvd.
La Habra, California 90631

Gentlemen:

The undersigned hereby proposes to perform all work for which a contract may be awarded him and to furnish any and all plant, labor, services, materials, tools, equipment, supplies, transportation, utilities, and all other items and facilities necessary therefor as provided in the Contract Documents, and to do everything required therein for the project specifically set forth in documents entitled:

**ANNUAL SIDEWALK IMPROVEMENTS PROJECT
FY 24-25, PROJECT NO. 1-R-25**

together with appurtenances thereto, all as set forth on the drawing and in the specifications and other Contract Documents; and, he further proposes and agrees that if this Proposal is accepted he will contract in the form and manner stipulated to perform all the work called for by drawings, specifications and other Contract Documents and to complete all such work in strict conformity therewith within the time limits set forth therein, and that he will accept as full payment therefor the prices set forth in the Bid Schedule forming a part hereof.

A *(Cashier's Check) *(Certified Check) *(Bid Bond) properly made payable to City of La Habra hereinafter designated as the Owner for the sum of _____

_____dollars (\$_____), which amount is not less than ten percent (10%) of the total amount of this bid, is attached hereto and is given as a guarantee that the undersigned will execute the Agreement and furnish the required bonds if awarded the Contract; and, in case of failure to do so within the time provided the proceeds of said check shall be forfeited to the *Owner/Sureties Liability to the Owner for forfeiture of the face amount of the Bond shall be considered as established.

(*) Delete inapplicable word or phrase.

It is understood and agreed that:

1. The undersigned has carefully examined all the Contract Documents which will form a part of the Contract;
2. The undersigned has, by investigation of the site of the work and otherwise, satisfied himself as to the nature and location of the work and has fully informed himself as to all conditions and matters which can in any way affect the work or the cost thereof;
3. The undersigned fully understands the scope of the work and has checked carefully all words and figures inserted in this proposal and he further understands that the Owner will in no way be responsible for any errors or omissions in the preparation of this proposal;

4. The undersigned will execute the Agreement and furnish the required Performance and Payment Bonds and proof of insurance coverage, within ten (10) days (not including Saturdays, Sundays and holidays) after notice to him of acceptance of his bid by the Owner; and further, that this bid may not be withdrawn for a period of sixty (60) days after the date set for the opening thereof, unless otherwise required by law. If any bidder shall withdraw his bid within said period, the Contractor shall be liable under the provisions of the Bid Security or the Contract and his surety shall be liable under the Bid Bond, as the case may be;
5. The undersigned hereby certifies that this proposal is genuine and not sham or collusive or made in the interest or in behalf of any person not herein named and the undersigned has not directly or indirectly induced or solicited any other bidder to put in a sham bid or any other person, firm or corporation to refrain from bidding; the undersigned has not in any manner sought by collusion to secure for himself an advantage over any other bidder;
6. In conformance with current statutory requirements of Section 1860, et seq., of the Labor Code of the State of California, the undersigned confirms the following as his certification:

I am aware of the provisions of Section 3700 of the Labor Code which requires every employer to be insured against liability of worker's compensation or to undertake self insurance in accordance with the provisions before commencing the performance of the work of this contract.

NOW, in compliance with the Notice Inviting Bids and all the provisions hereinbefore stipulated, the undersigned, with full cognizance thereof, hereby proposes to perform the entire work for the prices set forth in the attached Bid Schedule upon which award of the Contract is made.

Date: _____, 2025

Bidder _____

By _____

Title _____

Bidder's Post Office Address:

Corporation organized under
 the laws of the State of

Names and addresses of all owners
of the firm or names and titles of
all officers of the corporation:

(corporate seal)

BIDDER'S INFORMATION

Contractor's License No. _____ Expiration Date _____

Classification of Contractor's License No. _____

Contractor _____
(name of firm)

By _____
(signature) (title)

Business Address: _____

Phone () _____

I/We certify that the information provided above is complete and true to the best of my/our knowledge.

Contractor Date

Contractor's DIR Public Works Registration No. _____

BID SCHEDULE

**ANNUAL SIDEWALK IMPROVEMENTS PROJECT FY24-25
PROJECT NO. 1-R-25**

ITEM	DESCRIPTION	QUANTITY	UNIT	UNIT PRICE	AMOUNT
1	MOBILIZATION (Not to exceed Five Percent (5%) of the total bid amount)	1	LS		
2	STORM WATER BEST MANAGEMENT PRACTICES (BMPs)	1	LS		
3	TRAFFIC CONTROL, SAFETY, AND CLEANUP (Not to exceed Five Percent (5%) of the total bid amount)	1	LS		
4	REMOVE AND RECONSTRUCT 4" THICK CONCRETE SIDEWALK PER SPPWC DETAIL 112-2	7,000	SF		
5	REMOVE AND RECONSTRUCT 6" THICK CONCRETE DRIVEWAY APPROACH PER SPPWC DETAIL 110-2 WITH 1 FT. WIDTH AC SLOT	750	SF		
6	REMOVE AND RECONSTRUCT VARIABLE HEIGHT CONCRETE CURB & GUTTER OVER 6" CMB PER SPPWC DETAIL 120-3 WITH 1 FT. WIDTH AC SLOT	250	LF		
7	REMOVE STREET TREE (12 IN. TO 24 IN. DIAMATER)	11	EA		
8	PLANT 24" BOX STREET TREE AND STAKE, AND INSTALL ROOT BARRIERS PER SPPWC DETAIL 518-4 AND 520-5	11	EA		
9	REMOVE AND RECONSTRUCT CONCRETE WALKWAY WITH DETECTABLE WARNING SURFACE AND 1 FT. AC SLOT	200	SF		

Continued on next page

TOTAL BID PRICE FOR BID SCHEDULE IN WORDS: _____

Note: All bid quantities are estimated and for bidding purposes only, it may be increased or decreased at the discretion of the CITY. The provisions of Sections 7-3.5.2 and 7-3.5.3 of the Greenbook governing increases or decreases in quantity of more than 25% shall not apply.

Note: The TOTAL BID PRICE shall be used as the basis of bid in determining the low bid for this project.

CONTRACTOR

BY

TITLE

DATE

ACKNOWLEDGEMENT OF ADDENDA RECEIVED

The Bidder shall acknowledge the receipt of addenda by placing an “X” by each addendum received.

- Addendum No. 1 _____
- Addendum No. 2 _____
- Addendum No. 3 _____
- Addendum No. 4 _____
- Addendum No. 5 _____
- Addendum No. 6 _____
- Addendum No. 7 _____
- Addendum No. 8 _____

If an addendum or addenda have been issued by the CITY and is not noted above as being received by the Bidder, the Bid Proposal may be rejected.

REFERENCES

[Work similar in scope magnitude and degree of difficulty completed by Contractor within the past three (3) years.]

1. Name (Firm/Agency): _____
Address: _____
Contact Person: _____ Telephone No. _____
Title of Project: _____
Project Location: _____
Date of Completion: _____ Contract Amount: \$ _____
2. Name (Firm/Agency): _____
Address: _____
Contact Person: _____ Telephone No. _____
Title of Project: _____
Project Location: _____
Date of Completion: _____ Contract Amount: \$ _____
3. Name (Firm/Agency): _____
Address: _____
Contact Person: _____ Telephone No. _____
Title of Project: _____
Project Location: _____
Date of Completion: _____ Contract Amount: \$ _____
4. Name (Firm/Agency): _____
Address: _____
Contact Person: _____ Telephone No. _____
Title of Project: _____
Project Location: _____
Date of Completion: _____ Contract Amount: \$ _____

If Contractor has not performed work for the City of La Habra within the last five (5) years, list all work done within said five years (attach additional sheets if necessary). Note if work was done as subcontractor (include only subcontract amount):

Work Description & Contract Amount	Agency	Date Completed

Contractor's License No.: _____ Class: _____

a. Date first obtained: _____ Expiration: _____

b. Has License ever been suspended or revoked? _____

If yes, described when and why: _____

c. Any current claims against License or Bond? _____

If yes, describe claims: _____

Principals in Company (List all – attach additional sheets if necessary):

<u>NAME</u>	<u>TITLE</u>	<u>LICENSE NO.</u> (If Applicable)
_____	_____	_____
_____	_____	_____
_____	_____	_____

DBE BIDDER'S LIST

All bidders/proposers are requested to provide the following information for all DBE and non-DBE contractors or consultants who provided a proposal, bid, quote, or were contacted by the proposed prime. This information is also requested from the proposed prime contractor/consultant and should be submitted with their bid/proposal. The City of La Habra will use this information to maintain and update a "Bidders" List to assist in the overall annual DBE goal-setting process.

Firm Name: _____	Phone: _____
Address: _____	Fax: _____
Contact Person: _____	No. of years in business: _____
Is the firm currently certified as a DBE under 49 CFR Part 26: YES: ___ NO: ___	
Type of work/services/materials provided by firm? _____	

<hr/> <hr/> What was your firm's Gross Annual receipts for last year?	
Less than \$1 Million	
Less than \$5 Million	
Less than \$10 Million	
Less than \$15 Million	
More than \$15 Million	

This form can be duplicated if necessary to report all bidders (DBEs and non-DBEs) information.

VIOLATIONS OF FEDERAL, STATE, OR LOCAL LAWS

1. Has your firm or its officers been assessed any penalties by an agency for noncompliance or violations of Federal, State, or Local labor laws and/or business or licensing regulations within the past five (5) years relating to your construction projects?

Yes/No: _____ Federal/State: _____

If “yes”, identify and describe, (including agency and status):

Have the penalties been paid? Yes/No: _____

2. Does your firm or its officers have any ongoing investigations by any public agency regarding violations of the State Labor Code, California Business and Professions Code or State Licensing Laws?

Yes/No: _____ Code/Laws: _____ Section/Article: _____

If “yes”, identify and describe, (including agency and status):

DISQUALIFICATION OR DEBARMENT

Has your firm, any officer of your firm, or any employee who has a proprietary interest in your firm ever been disqualified, removed, or otherwise prevented from bidding on, performing work on, or completing a federal, state, or local project because of a violation of law or a safety regulation?

Yes/No: _____

If yes, provide the following information (if more than once, use separate sheets):

Date: _____ Entity: _____

Location: _____

Reason: _____

Provide Status and any Supplemental Statement: _____

Has your firm been reinstated by this entity?

Yes/No: _____

LIST OF SUBCONTRACTORS

**ANNUAL SIDEWALK IMPROVEMENTS PROJECT FY24-25
PROJECT NO.1-R-25**

The bidder shall list below the name and the location of the place of business of each Subcontractor who will perform work or render services to the prime contractor in or about the construction of the work or improvement in excess of one-half of one percent (1/2%) of the prime contractor's total bid or ten thousand dollars (\$10,000.00) whichever is greater in accordance with the requirements of Section 4100 to 4133 inclusive of the public contracts code.

<u>Work to be Performed</u> NO	<u>License Number</u>	<u>Subcontractor and Address of Office, Mill or Shops</u>	<u>Percent of Total Contract</u>	<u>DBE YES</u>

Note: Do not list alternative subcontractors for the same work.

Contractor _____

BID SECURITY FORM

(Check to Accompany Bid)

(Note: The following form shall be used in case check accompanies bid.)

Accompanying this proposal is a *(Certified) *(Cashiers) check payable to the order of the City of La Habra, California, hereinafter referred to as "Owner", for

**ANNUAL SIDEWALK IMPROVEMENT PROJECT FY24-25
PROJECT NO. 1-R-25**

In the amount of \$ _____ Dollars, this amount being ten percent (10%) of the total amount of the bid. The proceeds of this check shall become the property of said Owner provided this proposal shall be accepted by the said Owner through action of its legally constituted contracting authorities and the undersigned shall fail to execute a contract and furnish the required Performance and Payment Bonds and proof of insurance coverage within the stipulated time; otherwise, the check shall be returned to the undersigned. The proceeds of this check shall also become the property of the Owner if the undersigned shall withdraw his bid within the period of forty-five (45) days after the date set for the opening thereof unless otherwise required by law and notwithstanding the award of the Contract to another bidder.

Bidder

*Delete the inapplicable word.

NOTE: If the bidder desires to use a bond instead of a check, the Bid Bond form on the following pages shall be executed. The sum of this bond shall be not less than ten percent (10%) of the total amount of the bid.

BID BOND

KNOW ALL MEN BY THESE PRESENTS:

That we _____ as principal and _____ as surety, are held and firmly bound unto the City of La Habra, California hereinafter referred to as "Owner", in the sum of _____ Dollars (\$ _____) to be paid to the said Owner, its successors and assigns for which payment well and truly to be made we bind ourselves, our heirs, executors, administrators, successors and assigns, jointly and severally, firmly by these presents.

THE CONDITION OF THIS OBLIGATION IS SUCH that if the certain proposal of the above bounden for the construction of Street Improvements as specifically set forth in documents entitled:

**ANNUAL SIDEWALK IMPROVEMENTS PROJECT FY24-25
CITY PROJECT NO. 1-R-25**

all in accordance with the specifications and drawings on file at the offices of the City Clerk of the City of La Habra, California and is not withdrawn within the period of sixty (60) days after the date set for the opening of bids unless otherwise required by law and notwithstanding the award of the Contract to another bidder and that if said proposal is accepted by the Owner through action of its legally constituted contracting authorities and if the above bounden his heirs, executors, administrators, successors and assigns shall duly enter into and execute a contract for such construction and shall execute and deliver the required Performance and Payment Bonds and proof of insurance coverage within ten (10) days (not including Saturdays, Sundays and Holidays) after the date of notification by and from the said Owner that the said contract is ready for execution, then this obligation shall become null and void; otherwise, it shall be and remain in full force and virtue.

IN WITNESS WHEREOF, we hereunto set hands and seal this _____
day of _____, 2025.

BIDDER

NOTE: The standard printed bond form of any bonding company acceptable to the Owner may be used in lieu of the foregoing approved sample bond form provided the security stipulations protecting the Owner are not in any way reduced by use of the Surety Company's printed standard form.

NON-COLLUSION AFFIDAVIT
FOR

ANNUAL SIDEWALK IMPROVEMENTS PROJECT FY24-25
PROJECT NO. 1-R-25

(TO BE EXECUTED BY EACH AWARDEE OF A PRINCIPAL CONTRACT)

STATE OF CALIFORNIA)
) SS.
)

_____, being first duly sworn,
deposes and says that he is _____
(sole owner, partner, president, secretary, etc.)

of _____

The party making the foregoing bid; that such bid is not made in the interest of or on behalf of any undisclosed person, partnership, company, association, organization or corporation; that such bid is genuine and not collusive or sham: that said bidder has not directly or indirectly induced or solicited any other bidder to put in a false or sham bid, and has not directly or indirectly colluded, conspired, connived, or agreed with any bidder or anyone else to put in a sham bid, nor that anyone shall refrain from bidding; that said bidder has not in any manner directly or indirectly sought by agreement, communication or conference with anyone to fix the bid price of said bidder or of any other bidder, nor to fix any overhead, profit cost element of such bid price nor of that of any other bidder nor to secure any advantage against the public body awarding the contract or anyone interested in the proposed contract; that all statements contained in such bid are true; and, further, that said bidder has not directly or indirectly, submitted his bid price or any breakdown thereof, nor the contents thereof, nor divulged information or data relative thereto, nor paid and will not pay any fee in connection therewith to any corporation, partnership, company, association, organization, bid depository, nor to any member of agent thereof nor to any other individual except to such person or persons as have a partnership or other financial interest with said bidder in his general business.

Signed: _____

Title: _____

Subscribed and sworn to before me

This _____ day of _____, 2025

SEAL OF NOTARY PUBLIC

WORKER'S COMPENSATION CERTIFICATE

(AS REQUIRED BY SECTION 1861
OF THE CALIFORNIA LABOR CODE)

I am aware of the provisions of Section 3700 of the California Labor Code, which require every employer to be insured against liability for worker's compensation, or to undertake self-insurance in accordance with the provisions of said Code, and I will comply with such provisions before commencing the performance of the Work of this Contract.

Contractor _____

By _____

Title _____

Public Contract Code Section 10285.1 Statement

In conformance with Public Contract Code Section 10285.1 (Chapter 376, Stats. 1985), the bidder hereby declares under penalty of perjury under the laws of the State of California that the bidder **has ___**, **has not ___** been convicted within the preceding three years of any offenses referred to in that section, including any charge of fraud, bribery, collusion, conspiracy, or any other act in violation of any state or Federal antitrust law in connection with the bidding upon, award of, or performance of, any public works contract, as defined in Public Contract Code Section 1101, with any public entity, as defined in Public Contract Code Section 1100, including the Regents of the University of California or the Trustees of the California State University. The term "bidder" is understood to include any partner, member, officer, director, responsible managing officer, or responsible managing employee thereof, as referred to in Section 10285.1.

Note: The bidder must place a check mark after "has" or "has not" in one of the blank spaces provided. The above Statement is part of the Proposal. Signing this Proposal on the signature portion thereof shall also constitute signature of this Statement. Bidders are cautioned that making a false certification may subject the certifier to criminal prosecution.

Public Contract Code Section 10162 Questionnaire

In conformance with Public Contract Code Section 10162, the Bidder shall complete, under penalty of perjury, the following questionnaire:

Has the bidder, any officer of the bidder, or any employee of the bidder who has a proprietary interest in the bidder, ever been disqualified, removed, or otherwise prevented from bidding on, or completing a federal, state, or local government project because of a violation of law or a safety regulation?

Yes _____ No _____

If the answer is yes, explain the circumstances in the following space.

Public Contract Code Section 10232 Statement

In conformance with Public Contract Code Section 10232, the Contractor, hereby states under penalty of perjury, that no more than one final unappealable finding of contempt of court by a federal court has been issued against the Contractor within the immediately preceding two year period because of the Contractor's failure to comply with an order of a federal court which orders the Contractor to comply with an order of the National Labor Relations Board.

Note: The above Statement and Questionnaire are part of the Proposal. Signing this Proposal on the signature portion thereof shall also constitute signature of this Statement and Questionnaire.

Bidders are cautioned that making a false certification may subject the certifier to criminal prosecution.

SECTION E
SAMPLE AGREEMENT

**CITY OF LA HABRA
PUBLIC WORKS AGREEMENT FOR
ANNUAL SIDEWALK IMPROVEMENTS PROJECT FY24-25
CITY PROJECT NO. 1-R-25**

THIS AGREEMENT (herein "Agreement"), is made and entered into this ___ day of _____, 2025 and between the **CITY OF LA HABRA**, a municipal corporation (herein "City") and _____ (herein "Contractor"). The parties hereto agree as follows:

WITNESSETH:

A. WHEREAS, City requires the construction of roadway improvements as set forth more fully in this Agreement.

B. WHEREAS, Contractor represents to City that Contractor is qualified to perform said work and has submitted a proposal to City for the same.

C. WHEREAS, City desires to have Contractor perform said services on the terms and conditions set forth herein.

D. WHEREAS, no official or employee of City has a financial interest, within the provisions of Sections 1090-1092 of the California Government Code, in the subject matter of this Agreement.

NOW, THEREFORE, for and in consideration of the mutual covenants and conditions contained herein and for good and valuable consideration, the receipt and sufficiency of which is acknowledged by both parties, City and Contractor hereby agree as follows

1.0 DEFINITIONS

1.1 Definitions. As used in this Agreement, the following definitions shall be applicable:

- (a) Contractor. Contractor shall mean _____, a California corporation located at _____.
- (b) City. City shall mean the City of La Habra, a Municipal Corporation and General Law City, located at 110 E. La Habra Blvd, La Habra, California 90631.
- (c) City Council. City Council shall mean the City Council of the City of La Habra.
- (d) Contract Officer shall mean the person designated by the City Administrator or City Engineer of City and shall have the duties set forth in Section 5.2.
- (e) Services. Services shall mean the services to be performed by the Contractor pursuant to this Agreement.
- (f) Satisfactory. Satisfactory shall mean satisfactory to the City Administrator or his/her designee.

2.0 SERVICES OF CONTRACTOR

2.1 Scope of Services. In compliance with all terms and conditions of this Agreement, the Contractor shall provide those services specified in the "Scope of Services" attached hereto as Exhibit "A" and incorporated herein by this reference, which services may be referred to herein as the "services" or "work" hereunder. As a material inducement to the City entering into this Agreement, Contractor represents and warrants that Contractor is a provider of first class work and services and Contractor is experienced in performing the work and services contemplated herein and, in light of such status and experience, Contractor covenants that it shall follow the highest professional standards in performing the work and services required hereunder and that all materials will be of good quality, fit for the purpose intended.

2.2 Documents Included in Contract. This contract consists of this Agreement and any Exhibits, which are incorporated herein by this reference. In the event of an inconsistency, the terms of this Agreement shall govern.

2.3 Compliance with Law. All services rendered hereunder shall be provided in accordance with all ordinances, resolutions, statutes, rules, and regulations of the City and any Federal, State or local governmental agency having jurisdiction in effect at the time service is rendered, including but not limited to, the claims procedure set forth in Public Contract Code Section 9204, a summary of which is attached to this agreement as Exhibit "D."

2.4 Licenses, Permits, Fees and Assessments. Contractor shall obtain at its sole cost and expense such licenses, permits and approvals as may be required by law for the performance of the services required by this Agreement, including registration with the Department of Industrial Relations of the State of California as required by Labor Code Section 1725.5 before commencing performance under this Agreement. Contractor shall have the sole obligation to pay for any fees, assessments and taxes, plus applicable penalties and interest, which may be imposed by law and arise from or are necessary for the Contractor's performance of the services required by this Agreement, and shall indemnify, defend and hold harmless City against any such fees, assessments, taxes penalties or interest levied, assessed or imposed against City hereunder. Contractor shall be responsible for all subcontractors' compliance with this Section 2.4.

2.5 Familiarity with Work. By executing this Contract, Contractor warrants that Contractor (a) has thoroughly investigated and considered the scope of services to be performed, (b) has carefully considered how the services should be performed, and (c) fully understands the facilities, difficulties and restrictions attending performance of the services under this Agreement. If the services involve work upon any site, Contractor warrants that Contractor has or will investigate the site and is or will be fully acquainted with the conditions there existing, prior to commencement of services hereunder. Should Contractor discover any latent or unknown conditions, which will materially affect the performance of the services hereunder, Contractor shall immediately inform the City of such fact and shall not proceed except at Contractor's risk until written instructions are received from the Contract Officer.

2.6 Standard of Performance. Contractor, its subcontractors and their employees, in the performance of Contractor's work under this Agreement shall be responsible for exercising the degree of skill and care required by customarily accepted good professional practices and procedures used in the Contractor's field.

Any costs for failure to meet the foregoing standard or to correct otherwise defective work that requires re-performance of the work, shall be borne in total by the Contractor and not by the City. The failure of a

project to achieve the performance goals and objectives stated in this Agreement is not a basis for requesting re-performance unless the work conducted by Contractor and/or its subcontractors is deemed by the City to have failed the foregoing standard of performance.

In the event Contractor fails to perform in accordance with the above standard:

1. Contractor will re-perform, at its own expense, any task which was not performed to the reasonable satisfaction of City. Any work re-performed pursuant to this paragraph shall be completed within the time limitations originally set forth for the specific task involved. Contractor shall work any overtime required to meet the deadline for the task at no additional cost to the City;
2. The City shall provide a new schedule for the re-performance of any task pursuant to this paragraph in the event that re-performance of a task within the original time limitations is not feasible; and
3. The City shall have the option to direct Contractor not to re-perform any task which was not performed to the reasonable satisfaction of the City Project Manager pursuant to application of (1) and (2) above. In the event the City directs Contractor not to re-perform a task, the City shall negotiate a reasonable settlement for satisfactory work performed. No previous payment shall be considered a waiver of the City's right to reimbursement.

Nothing contained in this section is intended to limit any of the rights or remedies which the City may have under law.

2.7 Care of Work. The Contractor shall adopt reasonable methods during the life of the Agreement to furnish continuous protection to the work, and the equipment, materials, papers, documents, plans, studies and/or other components thereof to prevent losses or damages, and shall be responsible for all such damages, to persons or property, until acceptance of the work by City, except such losses or damages as may be caused by City's own negligence.

2.8 Further Responsibilities of Parties. Both parties agree to use reasonable care and diligence to perform their respective obligations under this Agreement. Both parties agree to act in good faith to execute all instruments, prepare all documents and take all actions as may be reasonably necessary to carry out the purposes of this Agreement. Unless hereafter specified, neither party shall be responsible for the service of the other. Contractor shall require all subcontractors to comply with the provisions of this agreement.

2.9 Additional Services. City shall have the right at any time during the performance of the services, without invalidating this Agreement, to order extra work beyond that specified in the Scope of Services or make changes by altering, adding to or deducting from said work. No such extra work may be undertaken unless a written change order is first given by the Contract Officer to the Contractor, incorporating therein any adjustment in (i) the Contract Sum as set forth in Section 3.1, and/or (ii) the time to perform this Agreement, which said adjustments are subject to the written approval of the Contractor. Any increase in compensation of twenty five percent (25%) or less of the Contract Sum, or in the time to perform of one hundred eighty (180) days or less may be approved by the Contract Officer. Any increases, taken either separately or cumulatively, that result in the Contract Sum exceeding \$25,000 must be approved by the City Council. It is expressly understood by Contractor that the provisions of this Section shall not apply to services specifically set forth in the Scope of Services or reasonably contemplated therein. Contractor hereby acknowledges that it accepts the risk that the services to be provided pursuant to the Scope of Services may be more costly or time consuming than Contractor anticipates and that Contractor shall not be entitled to additional compensation therefore.

2.10 Prevailing Wage Laws. Contractor represents and warrants that it is registered with the Department of Industrial Relations pursuant to SB 854 and Labor Code 1725.5. Contractor shall ensure that its subcontractors comply with said requirements. In accordance with Labor Code Section 1770 et seq., the Director of the Department of Industrial Relations of the State of California has ascertained a general prevailing rate of wages, which is the minimum amount, which shall be paid to all workers employed to perform the work pursuant to this Agreement. A copy of the general prevailing wage rate determination is on file in the Office of the City Clerk and is hereby incorporated by reference into this Agreement. In accordance with the provisions of Labor Code Section 1810 et seq., eight (8) hours is the legal working day. Contractor must forfeit to the City Twenty Five Dollars (\$25.00) a day for each worker who works in excess of the minimum working hours when Contractor does not pay overtime. Contractor is required to post a copy of such wage rates at all times at the contract site. The statutory penalties for failure to pay prevailing wage or to comply with State wage and hour laws will be enforced. Contractor also shall comply with State law requirements to maintain payroll records and shall provide for certified records and inspection of records as required by California Labor Code Section 1770 et. seq., including Section 1776. Contractor shall comply with all statutory requirements relating to the employment of apprentices.

3.0 COMPENSATION

3.1 Contract Sum. For the services rendered pursuant to this Agreement, the Contractor shall be compensated as specified herein, but not exceeding the maximum contract amount of ____ Dollars (\$____) (herein "Contract Sum"), except as provided in Section 2.9. The Contract Sum shall include the attendance of Contractor at all project meetings reasonably deemed necessary by the City; Contractor shall not be entitled to any additional compensation for attending said meetings.

3.2 Progress Payments. Prior to the first day of the month, during the progress of the work, commencing on the day and month specified in the Agreement, Contractor shall submit to the Contract Officer a complete itemized statement of all labor and materials incorporated into the work during the preceding month and the portion of the contract sum applicable thereto. Upon approval in writing by the Contract Officer, payment shall be made in thirty (30) days. City shall pay Contractor a sum based upon ninety-five percent (95%) of the contract price apportionment of the labor and materials incorporated into the work under the contract during the month covered by said statement. The remaining five percent (5%) thereof shall be retained as performance security. Refer to Section 8.4 of this Agreement for retention of funds.

4.0 PERFORMANCE SCHEDULE

4.1 Time of Essence. Time is of the essence in the performance of this Agreement.

4.2 Schedule of Performance. Contractor shall commence the services pursuant to this Agreement upon receipt of a written notice to proceed and shall perform all services within the time period(s) established in Exhibit "A", and incorporated herein by this reference. When requested by the Contractor, extensions to the time period(s) specified in the Scope of Services may be approved in writing by the Contract Officer.

4.3 Force Majeure. The time period(s) specified in the Scope of Services for performance of the services rendered pursuant to this Agreement shall be extended because of any delays due to unforeseeable causes beyond the control and without the fault or negligence of the Contractor, including, but not restricted to, acts of God or of the public enemy, unusually severe weather, fires, earthquakes, floods, epidemics, quarantine restrictions, riots, strikes, freight embargoes, wars, litigation, and/or acts of any governmental agency, including the City, if the Contractor shall within ten (10) days of the commencement of such delay notify the Contract

Officer in writing of the causes for the delay. The Contract Officer shall ascertain the facts and the extent of delay, and extend the time for performing the services for the period of the enforced delay when and if in the judgment of the Contract Officer such delay is justified. The Contract Officer's determination shall be final and conclusive upon the parties to this Agreement.

4.4 Term. Unless earlier terminated in accordance with Section 8.9 of this Agreement, this Agreement shall continue in full force and effect until final approval and acceptance of the project by the Contract Officer. Notwithstanding the foregoing, this Agreement shall terminate no later than June 30, 2027, unless the parties mutually agree in writing to extend the term.

5.0 COORDINATION OF WORK

5.1 Representative of Contractor. The following principals of Contractor are hereby designated as being the principals and representatives of Contractor authorized to act in its behalf with respect to the work specified herein and make all decisions in connection therewith:

It is expressly understood that the experience, knowledge, capability and reputation of the foregoing principals were a substantial inducement for City to enter into this Agreement. Therefore, the foregoing principals shall be responsible during the term of this Agreement for directing all activities of Contractor and devoting sufficient time to personally supervise the services hereunder. For purposes of this Agreement, the foregoing principals may not be replaced nor may their responsibilities be substantially reduced by Contractor without the express written approval of City.

5.2 Contract Officer. The Contract Officer shall be such person as may be designated by the City Administrator or City Engineer of City. It shall be the Contractor's responsibility to assure that the Contract Officer is kept informed of the progress of the performance of the services and the Contractor shall refer any decisions that must be made by City to the Contract Officer. Unless otherwise specified herein, any approval of City required hereunder shall mean the approval of the Contract Officer. The Contract Officer shall have authority to sign all documents on behalf of the City required hereunder to carry out the terms of this Agreement.

5.3 Prohibition Against Assignment. The experience, knowledge, capability and reputation of Contractor, its principals and employees were a substantial inducement for the City to enter into this Agreement. Neither this Agreement nor any interest herein may be transferred, assigned, conveyed, hypothecated or encumbered voluntarily or by operation of law, whether for the benefit of creditors or otherwise, without the prior written approval of City. Transfers restricted hereunder shall include the transfer to any person or group of persons acting in concert of more than twenty five percent (25%) of the present ownership and/or control of Contractor, taking all transfers into account on a cumulative basis. In the event of any such unapproved transfer, including any bankruptcy proceeding, this Agreement shall be void. No approved transfer shall release the Contractor or any surety of Contractor of any liability hereunder without the express consent of City.

5.4 Independent Contractor. Neither the City nor any of its employees shall have any control over the manner, mode or means by which Contractor, its subcontractors, agents or employees, performs the services required herein, except as otherwise set forth herein. City shall have no voice in the selection, discharge, supervision or control of Contractor's employees, subcontractors, servants, representatives

or agents, or in fixing their number, compensation or hours of service. Contractor shall perform all services required herein as an independent contractor of City and shall remain at all times as to City a wholly independent contractor with only such obligations as are consistent with that role. Contractor shall not at any time or in any manner represent that it or any of its subcontractors, agents or employees are agents or employees of City. City shall not in any way or for any purpose become or be deemed to be a partner of Contractor in its business or otherwise or a joint venture or a member of any joint enterprise with Contractor.

5.5 Identity of Persons Performing Work. Contractor represents that it employs or will employ at its own expense all personnel required for the satisfactory performance of any and all tasks and services set forth herein. Contractor represents that the tasks and services required herein will be performed by Contractor or under its direct supervision, and that all personnel engaged in such work shall be fully qualified and shall be authorized and permitted under applicable State and local law to perform such tasks and services.

5.6 Utility Relocation. City is responsible for removal, relocation, or protection of existing main or trunkline utilities to the extent such utilities were not identified in the invitation for bids or specifications. City shall reimburse contractor for any costs incurred in locating, repairing damage not caused by contractor and removing or relocating such unidentified utility facilities, including equipment idled during such work. Contractor shall not be assessed liquidated damages for delay arising from the removal or relocation of such unidentified utility facilities.

5.7 Trenches or Excavations. Pursuant to California Public Contract Code Section 7104, in the event the work included in this Agreement requires excavations more than four (4) feet in depth, the following shall apply.

- (a) Contractor shall promptly, and before the following conditions are disturbed, notify City, in writing, of any: (1) material that Contractor believes may be material that is hazardous waste, as defined in Section 25117 of the Health and Safety Code, that is required to be removed to a Class I, Class II, or Class III disposal site in accordance with provisions of existing law; (2) Subsurface or latent physical conditions at the site different from those indicated; or (3) Unknown physical conditions at the site of any unusual nature, different materially from those ordinarily encountered and generally recognized as inherent in work of the character provided for in the contract.
- (b) City shall promptly investigate the conditions, and if it finds that the conditions do materially so differ, or do involve hazardous waste, and cause a decrease or increase in Contractor's cost of, or the time required for, performance of any part of the work shall issue a change order per Section 2.9 of this Agreement.
- (c) That, in the event that a dispute arises between City and Contractor whether the conditions materially differ, or involve hazardous waste, or cause a decrease or increase in Contractor's cost of, or time required for, performance of any part of the work, Contractor shall not be excused from any scheduled completion date provided for by the contract, but shall proceed with all work to be performed under the contract. Contractor shall retain any and all rights provided either by contract or by law, which pertain to the resolution of disputes and protests between the contracting parties.

6.0 INSURANCE, INDEMNIFICATION AND BONDS

6.1 Insurance. The Contractor and all subcontractors, if any, shall procure and maintain, at its sole cost and expense, in a form and content satisfactory to City, during the entire term of this Agreement including any extension thereof, insurance as set forth in Exhibit "B" attached hereto and incorporated herein by this reference.

Conditions:

In accordance with Public Contract Code Section 20170, the insurance of surety companies who provide or issue the policy shall have been admitted to do business in the State of California with a credit rating of A- or better.

This insurance shall not be canceled, limited in scope or coverage or non-renewed until after thirty (30) days prior written notice has been given to the Public Works Director, City of La Habra, 110 E. La Habra Blvd., La Habra, California 90631.

Any insurance maintained by the City of La Habra shall apply in excess of and not combined with insurance provided by this policy.

The City of La Habra, its officers, employees, representatives, attorneys, and volunteers shall be named as additional named insureds.

Prior to commencement of any work under this contract, Contractor shall deliver to the City insurance endorsements confirming the existence of the insurance required by this contract, and including the applicable clauses referenced above.

Such endorsements shall be signed by an authorized representative of the insurance company and shall include the signator's company affiliation and title. Should it be deemed necessary by the City, it shall be Contractor's responsibility to see that the City receives documentation, acceptable to the City, which sustains that the individual signing said endorsements is indeed authorized to do so by the insurance company.

If the Contractor fails to maintain the aforementioned insurance, or secure and maintain the aforementioned endorsement, the City may obtain such insurance, and deduct and retain the amount of the premiums for such insurance from any sums due under the agreement. However, procuring of said insurance by the City is an alternative to other remedies the City may have, and is not the exclusive remedy for failure of Contractor to maintain said insurance or secure said endorsement. In addition to any other remedies the City may have upon Contractor's failure to provide and maintain any insurance or policy endorsements to the extent and within the time herein required, the City shall have the right to order Contractor to stop work hereunder, and/or withhold any payment(s) which became due to Contractor hereunder until Contractor demonstrates compliance with the requirements hereof.

Nothing herein contained shall be construed as limiting in any way the extent to which Contractor may be held responsible for payments of damages to persons or property resulting from Contractor's or its subcontractor's performance of the work covered under this agreement.

Each contract between the Contractor and any subcontractor shall require the subcontractor to maintain the same policies of insurance that the Contractor is required to maintain pursuant to this Section 6.1 and Exhibit "B".

6.2 Certificates of Insurance. Contractor shall provide to City certificates of insurance showing the insurance coverages and required endorsements described above, in a form and content approved by City, prior to performing any services under this Agreement. The certificates of insurance and endorsements shall be attached to this Agreement as Exhibit "C", and are incorporated herein by this reference.

6.3 Indemnification. Contractor shall defend, indemnify, hold free and harmless the City of La Habra, its elected and appointed officials, officers, agents and employees, at Contractor's sole expense, from and against any and all actions, suits, claims, damages to persons or property, losses, costs, penalties, obligations, errors, omissions or liabilities, (herein "claims or liabilities") that may be asserted or claimed by any person, firm or entity arising or alleged to arise out of or in connection with the performance of the work, operations or activities of Contractor, its agents, employees, subcontractors, or invitees, provided for herein, or arising or alleged to arise from the negligent acts or omissions of Contractor hereunder, or arising or alleged to arise from Contractor's performance of or failure to perform any term, provision, covenant or condition of this Agreement.

- (a) Contractor will defend any action or actions filed in connection with any of said claims or liabilities and will pay all costs and expenses, including legal costs and attorneys' fees incurred in connection therewith.
- (b) Contractor will promptly pay any judgment rendered against the City, its officers, agents or employees for any such claims or liabilities arising or alleged to arise out of or in connection with Contractor's (or its agents', employees', subcontractors' or invitees') negligent performance of or failure to perform such work, operations or activities hereunder; and Contractor agrees to save and hold the City, its officers, agents, and employees harmless therefrom.
- (c) In the event the City, its officers, agents or employees is made a party to any action or proceeding filed or prosecuted against Contractor for such damages or other claims arising or alleged to arise out of or in connection with the performance of or failure to perform the work, operation or activities of Contractor hereunder, Contractor shall pay to the City, its officers, agents or employees, any and all costs and expenses incurred by the City, its officers, agents or employees in such action or proceeding, including but not limited to, legal costs and attorneys' fees for counsel selected by City.
- (d) Contractor's duty to defend and indemnify as set out in this Section 6.3 shall include any claims, liabilities, obligations, losses, demands, actions, penalties, suits, costs, expenses or damages or injury to persons or property arising or alleged to arise from, in connection with, as a consequence of or pursuant to any state or federal law or regulation regarding hazardous substances, including but not limited to the Federal Insecticide, Fungicide and Rodenticide Act ("FIFRA"), Comprehensive Environmental Response, Compensation and Liability Act of 1980 ("CERCLA"), Resource Conservation and Recovery Act of 1976 ("RCRA"), the Hazardous and Solid Waste Amendments of 1984, the Hazardous Material Transportation Act, the Toxic Substances control Act, the Clean Air Act, the Clean Water Act, the California Hazardous Substance Account Act, the California Hazardous Waste Control Law or the Porter-Cologne Water Quality Control Act, as any of those statutes may be amended from time to time.

Notwithstanding the foregoing, Contractor shall not be liable for the defense or indemnification of the City for claims, actions, complaints or suits arising out of the sole active negligence or willful misconduct of the City.

The Contractor's indemnification obligations pursuant to this Section 6.3 shall survive the termination of this Agreement. Contractor shall require the same indemnification from all subcontractors.

6.4 Labor and Materials and Performance Bonds. Concurrently with execution of this Agreement, Contractor shall deliver to City a labor and materials bond and a performance bond each in the sum of the amount of this Agreement, in the forms provided by the City Clerk, which secures the faithful performance of this Agreement. The bonds shall contain the original notarized signature of an authorized officer of the surety and affixed thereto shall be a certified and current copy of his power of attorney. The bonds shall be unconditional and remain in force during the entire term of the Agreement and shall be null and void only if the Contractor promptly and faithfully performs all terms and conditions of this Agreement.

6.5 Sufficiency of Insurer or Surety. Insurance required by this Agreement shall be satisfactory only if issued by companies qualified to do business in California, rated "A" or better in the most recent edition of Best Rating Guide, The Key Rating Guide or in the Federal Register, and only if they are of a financial category Class VII or better, unless such requirements are waived by the Risk Manager of the City due to unique circumstances.

6.6 Substitution of Securities. Pursuant to California Public Contract Code Section 22300, substitution of eligible equivalent securities for any monies withheld to ensure performance under the contract for the work to be performed will be permitted at the request and expense of the successful bidder.

7.0 RECORDS AND REPORTS

7.1 Reports. Contractor shall periodically prepare and submit to the Contract Officer such reports concerning the performance of the services required by this Agreement as the Contract Officer shall require. Contractor hereby acknowledges that the City is greatly concerned about the cost of work and services to be performed pursuant to this Agreement. For this reason, Contractor agrees that if Contractor becomes aware of any facts, circumstances, techniques, or events that may or will materially increase or decrease the cost of the work or services contemplated herein or, if Contractor is providing design services, the cost of the project being designed, Contractor shall promptly notify the Contract Officer of said fact, circumstance, technique or event and the estimated increased or decreased cost related thereto and, if Contractor is providing design services, the estimated increased or decreased cost estimate for the project being designed.

7.2 Records. Contractor shall keep, and require subcontractors to keep, such books and records (including but not limited to payroll records as required herein) as shall be necessary to perform the services required by this Agreement and enable the Contract Officer to evaluate the performance of such services. The Contract Officer shall have full and free access to such books and records at all times during normal business hours of City, including the right to inspect, copy, audit and make records and transcripts from such records. Such records shall be maintained for a period of three (3) years following completion of the services hereunder, and the City shall have access to such records in the event any audit is required.

7.3 Ownership of Documents. All drawings, specifications, reports, records, documents and other materials prepared by Contractor, its employees, subcontractors and agents in the performance of this Agreement shall be the property of City and shall be delivered to City upon request of the Contract Officer or upon the termination of this Agreement, and Contractor shall have no claim for further employment or additional compensation as a result of the exercise by City of its full rights of ownership of the documents and materials hereunder. Contractor may retain copies of such documents for its own use. Contractor shall have an unrestricted right to use the concepts embodied therein. All subcontractors shall

provide for assignment to City of any documents or materials prepared by them, and in the event Contractor fails to secure such assignment, Contractor shall indemnify City for all damages resulting therefrom.

7.4 Public Records Act Disclosure. Contractor has been advised and is aware that this Agreement and all reports, documents, information and data, including, but not limited to, computer tapes, discs or files furnished or prepared by Contractor, or any of its subcontractors, pursuant to this Agreement and provided to City may be subject to public disclosure as required by the California Public Records Act (California Government Code Section 6250 *et seq.*). Exceptions to public disclosure may be those documents or information that qualify as trade secrets, as that term is defined in the California Government Code Section 6254.7, and of which Contractor informs City of such trade secret. The City will endeavor to maintain as confidential all information obtained by it that is designated as a trade secret. The City shall not, in any way, be liable or responsible for the disclosure of any trade secret including, without limitation, those records so marked if disclosure is deemed to be required by law or by order of the Court.

8.0 GENERAL PROVISIONS

8.1 Governing Law. This Agreement shall be construed and interpreted both as to validity and to performance of the parties in accordance with the laws of the State of California. Legal actions concerning any dispute, claim or matter arising out of or in relation to this Agreement shall be instituted in the Superior Court of the County of Orange, State of California, or any other appropriate court in such county, and Contractor covenants and agrees to submit to the personal jurisdiction of such court in the event of such action.

8.2 Representatives. The City Administrator or his or her designee shall be the representative of City for purposes of this Agreement and may issue all consents, approvals, directives and agreements on behalf of the City, called for by this Agreement, except as otherwise expressly provided in this Agreement.

The Principal set forth in Section 5.1 above shall be the representative for Contractor for purposes of this Agreement, and shall be authorized to issue all consents, approvals, directives and agreements on behalf of Contractor called for by this Agreement, except as otherwise expressly provided in this Agreement.

8.3 Disputes. In the event either party fails to perform its obligations hereunder, the nondefaulting party shall provide the defaulting party written notice of such default. The defaulting party shall have ten (10) days to cure the default; provided that, if the default is not reasonably susceptible to being cured within said ten (10) day period, the defaulting party shall have a reasonable time to cure the default, not to exceed a maximum of thirty (30) days, so long as the defaulting party commences to cure such default within ten (10) days of service of such notice and diligently prosecutes the cure to completion; provided further that if the default is an immediate danger to the health, safety and general welfare, the defaulting party shall take such immediate action as may be necessary. Notwithstanding the foregoing, the nondefaulting party may, in its sole and absolute discretion, grant a longer cure period. Should the defaulting party fail to cure the default within the time period provided in this Section, the nondefaulting party shall have the right, in addition to any other rights the nondefaulting party may have at law or in equity, to terminate this Agreement. Compliance with the provisions of this Section 8.3 shall be a condition precedent to bringing any legal action, and such compliance shall not be a waiver of any party's right to take legal action in the event that the dispute is not cured.

8.4 Retention of Funds. Progress payments shall be made in accordance with the provisions of Section 3.2 of this Agreement. In accordance with said section, City shall pay Contractor a sum based upon ninety-five percent (95%) of the contract price apportionment of the labor and materials incorporated into

the work under the contract during the month covered by said statement. The remaining five percent (5%) thereof shall be retained as performance security to be paid to the Contractor within sixty (60) days after final acceptance of the work by the City Council, after Contractor shall have furnished City with a release of all undisputed contract amounts if required by City. In the event there are any claims specifically excluded by Contractor from the operation of the release, the City may retain proceeds (per Public Contract Code 7107) of up to 150% of the amount in dispute. City's failure to deduct or withhold shall not affect Contractor's obligations hereunder.

8.5 Waiver. No delay or omission in the exercise of any right or remedy by a nondefaulting party on any default shall impair such right or remedy or be construed as a waiver. A party's consent to or approval of any act by the other party requiring the party's consent or approval shall not be deemed to waive or render unnecessary the other party's consent to or approval of any subsequent act. Any waiver by either party of any default must be in writing and shall not be a waiver of any other default concerning the same or any other provision of this Agreement.

8.6 Rights and Remedies. Rights and Remedies are cumulative except with respect to rights and remedies expressly declared to be exclusive in this Agreement, the rights and remedies of the parties are cumulative and the exercise by either party of one or more of such rights or remedies shall not preclude the exercise by it, at the same or different times, of any other rights or remedies for the same default or any other default by the other party.

8.7 Legal Action. In addition to any other rights or remedies, either party may take legal action, in law or in equity, to cure, correct or remedy any default, to recover damages for any default, to compel specific performance of this Agreement, to obtain declaratory or injunctive relief, or to obtain any other remedy consistent with the purposes of this Agreement.

8.8 Liquidated Damages. Since the determination of actual damages for any delay in performance of this Agreement would be extremely difficult or impractical to determine in the event of a breach of this Agreement, the Contractor and its sureties shall be liable for and shall pay to the City Five Hundred Dollars (\$500.00) as liquidated damages for each working day of delay in the performance of any service required hereunder, as specified in the Scope of Services (Exhibit A). The City may withhold from any monies payable on account of services performed by the Contractor any accrued liquidated damages.

8.9 Termination for Default of Contractor. If termination is due to the failure of the Contractor to fulfill its obligations under this Agreement, Contractor shall vacate any City owned property which Contractor is permitted to occupy hereunder and City may, after compliance with the provisions of Section 8.3, take over the work and prosecute the same to completion by contract or otherwise, and the Contractor shall be liable to the extent that the total cost for completion of the services required hereunder exceeds the compensation herein stipulated (provided that the City shall use reasonable efforts to mitigate such damages), and City may withhold any payments to the Contractor for the purpose of setoff or partial payment of the amounts owed the City as previously stated.

8.10 Notice. Any notice, demand, request, document, consent, approval, or communication either party desires or is required to give to the other party or any other person shall be in writing and shall be deemed to be given when served personally or deposited in the US Mail, prepaid, first-class mail, return receipt requested, addressed as follows:

To City: City of La Habra
110 E. La Habra Blvd
La Habra, California 90631
Attn.: Albert Mendoza

To Contractor:

8.11 Non-liability of City Officers and Employees. No officer or employee of the City shall be personally liable to the Contractor, or any successor in interest, in the event of any default or breach by the City or for any amount which may become due to the Contractor or to its successor, or for breach of any obligation of the terms of this Agreement.

8.12 Conflict of Interest. The Contractor warrants that it has not paid or given and will not pay or give any third party any money or other consideration for obtaining this Agreement.

Contractor and its officers, employees, associates and subcontractors, if any, will comply with all conflict of interest statutes of the State of California applicable to Contractor's services under this agreement, including, but not limited to, the Political Reform Act (Government Code Sections 81000, *et seq.*) and Government Code Section 1090. During the term of this Agreement, Contractor and its officers, employees, associates and subcontractor shall not, without the prior written approval of the City Representative, perform work for another person or entity for whom Contractor is not currently performing work that would require Contractor or one of its officers, employees, associates or subcontractors to abstain from a decision under this Agreement pursuant to a conflict of interest statute.

8.13 Covenant Against Discrimination. Contractor covenants that, by and for itself, its heirs, executors, assigns, and all persons claiming under or through them, that there shall be no discrimination against or segregation of, any person or group of persons on account of race, color, creed, religion, sex, marital status, national origin, or ancestry in the performance of this Agreement. To the extent required by law, contractor shall take affirmative action to insure that applicants are employed and that employees are treated during employment without regard to their race, color, creed, religion, sex, marital status, national origin, or ancestry.

8.14 Interpretation. The terms of this Agreement shall be construed in accordance with the meaning of the language used and shall not be construed for or against either party by reason of the authorship of this Agreement or any other rule of construction which might otherwise apply.

8.15 Severability. In the event that any one or more of the phrases, sentences, clauses, paragraphs, or sections contained in this Agreement shall be declared invalid or unenforceable by a valid judgment or decree of a court of competent jurisdiction, such invalidity or unenforceability shall not affect any of the remaining phrases, sentences, clauses, paragraphs, or sections of this Agreement which are hereby declared as severable and shall be interpreted to carry out the intent of the parties hereunder unless the invalid provision is so material that its invalidity deprives either party of the basic benefit of their bargain or renders this Agreement meaningless.

8.16 [reserved]

8.17 Unfair Business Practices Claims. In entering into a public works contract or a subcontract to supply goods, services or materials pursuant to a public works contract, the contractor or subcontractor offers and agrees to assign to the awarding body all rights, title, and interest in and to all causes of action it may have under Section 4 of the Clayton Act (15 U.S.C. Sec. 15) or under the Cartwright Act (Chapter 2, (commencing with Section 16700) of Part 2 of Division 7 of the Business and Professions

Code), arising from purchases of goods, services or materials pursuant to the public works contract or the subcontract. This assignment shall be made and become effective at the time the awarding body renders final payment to the contractor without further acknowledgment by the parties. (Sec. 7103.5, California Public Contract Code).

8.18 Corporate Authority. The persons executing this Agreement on behalf of the parties hereto warrant that (i) such party is duly organized and existing, (ii) they are duly authorized to execute and deliver this Agreement on behalf of said party, (iii) by so executing this Agreement, such party is formally bound to the provisions of this Agreement, and (iv) the entering into this Agreement does not violate any provision of any other Agreement to which said party is bound.

8.19 PERS Eligibility Indemnification. In the event that Contractor or any employee, agent, or subcontractor of Contractor providing services under this Agreement claims or is determined by a court of competent jurisdiction or the California Public Employees Retirement System (PERS) to be eligible for enrollment in PERS as an employee of the City, Contractor shall indemnify, defend, and hold harmless City for the payment of any employee and/or employer contributions for PERS benefits on behalf of Contractor or its employees, agents, or subcontractors, as well as for the payment of any penalties and interest on such contributions, which would otherwise be the responsibility of City.

Notwithstanding any other agency, state or federal policy, rule, regulation, law or ordinance to the contrary, Contractor and any of its employees, agents, and subcontractors providing service under this Agreement shall not qualify for or become entitled to, and hereby agree to waive any claims to, any compensation, benefit, or any incident of employment by City, including but not limited to eligibility to enroll in PERS as an employee of City and entitlement to any contribution to be paid by City for employer contribution and/or employee contributions for PERS benefits.

8.20 Cooperation. In the event any claim or action is brought against City relating to Contractor's performance or services rendered under this Agreement, Contractor shall render any reasonable assistance and cooperation which City might require.

8.21 Legal Responsibilities. The Contractor shall keep itself informed of City, State, and Federal laws, ordinances and regulations, which may in any manner affect the performance of its services pursuant to this Agreement. The Contractor shall at all times observe and comply with all such laws, ordinances and regulations. Neither the City, nor its officers, agents, or employees shall be liable at law or in equity as a result of the Contractor's failure to comply with this section.

8.22 Termination for Convenience. The City may terminate this Agreement without cause for convenience of the City upon giving contractor 30 days prior written notice of termination of the Agreement. Upon receipt of the notice of termination the Contractor shall cease all further work pursuant to the Agreement. Upon such termination by the City the Contractor shall not be entitled to any other remedies, claims, actions, profits, or damages except as provided in this paragraph. Upon the receipt of such notice of termination Contractor shall be entitled to the following compensation:

1. The contract value of the work completed to and including the date of receipt of the notice of termination, less the amount of progress payments received by contractor.

2. Actual move-off costs including labor, rental fees, equipment transportation costs, the costs of maintaining on-site construction office for supervising the mover-off.

3. The cost of materials custom made for this Agreement which cannot be used by the Contractor in the normal course of his business, and which have not been paid for by City in progress payments.

4. All costs shall not include any markups as might otherwise be allowed by any plans or specifications which were a part of the Agreement.

The provisions of this paragraph shall supersede any other provision of the Agreement or any provision of any plans, specification, addendums or other documents which are or may become a part of this Agreement. City and Contractor agree that the provisions of this paragraph are a substantive part of the consideration for this Agreement.

8.23 Responsibility for Errors. Contractor shall be responsible for its work and results under this Agreement. Contractor, when requested, shall furnish clarification and/or explanation as may be required by the City's representative, regarding any services rendered under this Agreement at no additional cost to City. In the event that an error or omission attributable to Contractor occurs, then Contractor shall, at no cost to City, provide all necessary design drawings, estimates and other Contractor professional services necessary to rectify and correct the matter to the sole satisfaction of City and to participate in any meeting required with regard to the correction.

8.24 Order of Precedence. In the event of an inconsistency in this Agreement and any of the attached Exhibits, the terms set forth in this Agreement shall prevail. If, and to the extent this Agreement incorporates by reference any provision of any document, such provision shall be deemed a part of this Agreement. Nevertheless, if there is any conflict among the terms and conditions of this Agreement and those of any such provision or provisions so incorporated by reference, this Agreement shall govern over the document referenced.

8.25 Costs. Each party shall bear its own costs and fees incurred in the preparation and negotiation of this Agreement and in the performance of its obligations hereunder except as expressly provided herein.

8.26 No Third Party Beneficiary Rights. This Agreement is entered into for the sole benefit of City and Contractor and no other parties are intended to be direct or incidental beneficiaries of this Agreement and no third party shall have any right in, under or to this Agreement.

8.27 Headings. Paragraphs and subparagraph headings contained in this Agreement are included solely for convenience and are not intended to modify, explain or to be a full or accurate description of the content thereof and shall not in any way affect the meaning or interpretation of this Agreement.

8.28 Construction. The parties have participated jointly in the negotiation and drafting of this Agreement. In the event an ambiguity or question of intent or interpretation arises with respect to this Agreement, this Agreement shall be construed as if drafted jointly by the parties and in accordance with its fair meaning. There shall be no presumption or burden of proof favoring or disfavoring any party by virtue of the authorship of any of the provisions of this Agreement.

8.29 Counterparts. This Agreement may be executed in one or more counterparts, each of which shall be deemed an original. All counterparts shall be construed together and shall constitute one agreement.

8.30 Funding Source Conditions – Contractor’s Obligation. Contractor acknowledges that the City may be paying for the Project by using funds it receives or will receive from various funding sources in the form of grants and/or subsidies, and the like under certain terms and conditions. Contractor acknowledges and agrees that any failure of the Contractor and/or its subcontractors to perform its obligations under the Contract, including, but not limited to, timely submitting accurate reports and records, that in any way results in the City not meeting the terms and conditions placed on the funds by the funding source, or forfeiting its entitlement to or, otherwise, not receiving, the funds, then the Contractor shall be liable to pay the City for the funds not granted to the City on the Project.

8.31 Entire Agreement. This Agreement constitutes the entire agreement between the parties with respect to any matter referenced herein and supersedes any and all other prior writings and oral negotiations. This Agreement may be modified only in writing, and signed by the parties in interest at the time of such modification. The terms of this Agreement shall prevail over any inconsistent provision in any other contract document appurtenant hereto, including exhibits to this Agreement.

SAMPLE

IN WITNESS WHEREOF, the parties have executed and entered into this Agreement as of the date first written above.

CITY OF LA HABRA,
A municipal corporation

Jim Sadro, City Manager

Date: _____

CONTRACTOR

Signature

Date: _____

Name and Title

Social Security or Taxpayer ID Number

ATTEST:

Rhonda J. Barone, City Clerk

Date: _____

APPROVED AS TO FORM:

Keith F. Collins, City Attorney

Date: _____

SAMPLE

(Use of City Bond Form is Required)

**LABOR AND MATERIAL PAYMENT BOND
PUBLIC WORK (CALIFORNIA)**

KNOW ALL MEN BY THESE PRESENT:

WHEREAS, _____, as Principal, has entered into a contract dated _____, with the City of La Habra (Obligee) referred to and made a part hereof to perform the following work, to wit: _____ and all appurtenant work in accordance with PROJECT NO. _____, which requires Principal to file this bond to secure claims made in relation to the project.

NOW THEREFORE, we, _____, as Principal, and _____, a corporation organized under the laws of _____ and duly authorized to transact business in the State of California, as Surety, are held firmly bound unto the City of La Habra, as Obligee, and all sub-contractors, laborers, material persons and other persons employed in the performance of the referenced agreement, in the sum of _____ Dollars (\$ _____ .00), lawful money of the United States of America, for the payment whereof well and truly to be made the Principal and Surety bind themselves, their heirs, executors, administrators, successors, and assigns, jointly and severally, firmly by these presents.

If the above bounden PRINCIPAL, his or its heirs, executors, administrators, successors, assigns, or any of his or its sub-contractors, fails to pay for any materials, provisions, provender, or other supplies, or teams, implements or machinery, used in, upon, for or about the performance of the work contracted to be done, or for any work or labor to persons named in Section 9100 or the Civil Code, thereon of any kind, or for amounts due under the Unemployment Insurance Code with respect to such work or labor deducted, withheld and paid over to the Employment Development Department from the wages of employees of the contractor and sub-contractors pursuant to Section 13020 of the Unemployment Insurance Code, that the SURETY on this bond will pay the same, in an amount not exceeding the sum specified in this bond, AND ALSO, in case suit is brought upon this bond, a reasonable attorney's fee, which shall be awarded by the court to the prevailing party in said suit, said attorney's fee to be taxed as costs in said suit and to be included in the judgment herein rendered.

As part of the obligation secured hereby, the SURETY shall not be exonerated or released from the obligation of the bond by any change, alteration, or modification in or of any contract, plans, specifications, or agreement pertaining or relating to any scheme or work of improvement or pertaining or relating to the furnishing of labor, materials, or equipment therefor, nor by any change or modification of any terms of payment or extension of the time for any payment pertaining or relating to any scheme of work of improvement, nor by any rescission or attempted rescission of the contract, agreement or bond, nor by any conditions precedent or subsequent in the bond attempting to limit the right of recovery of claimants otherwise entitled to recover under

any such contract or agreement, or under the bond, nor, where the bond is given for the benefit of claimants, by any fraud practiced by any person other than the claimant seeking to recover on the bond.

This bond shall inure to the benefit of any and all persons, companies and corporations entitled to file claims under the Civil Code so as to give them a right of action in a suit on this bond.

This bond is executed for the purpose of complying with the laws of the State of California and shall inure to the benefit of any of the persons named in Section 9100 of the Civil Code of the State of California.

IN WITNESS THEREOF, we have hereunto set our hands and seals this _____ day of _____, 2025.

(Corporate Seal)

Principal

By _____

Title

(Corporate Seal)

Principal

By _____

Title

APPROVED AS TO FORM:
/s/ Keith F. Collins
City Attorney

FAITHFUL PERFORMANCE BOND

KNOW ALL MEN BY THESE PRESENTS:

That we, _____

_____ hereinafter referred to as

“Contractor”, as principal, and _____

_____ as surety, are held and firmly

bound unto City of La Habra in the sum of _____

_____ Lawful money of the United States of America for the payment of which sum well and truly to be made we bind ourselves jointly and severally, firmly by these presents.

The condition of the foregoing obligation is such that WHEREAS, said Contract has been awarded and is about to enter into the annexed contract with City of La Habra for construction of Street Improvements as specifically set forth in the documents entitled:

**ANNUAL SIDEWALK IMPROVEMENTS PROJECT
CITY PROJECT NO. 1-R-25 FY24-25**

and is required under the terms of the Contract to give this bond in connection with the execution of said contract.

NOW, THEREFORE, if the said Contractor shall well and truly do and perform all of the covenants and obligations of said contract on his part to be done and performed at the times and in the manner specified herein, then this obligation shall be null and void, otherwise it shall be and remain in full force and effect.

PROVIDED, that any alterations in the work to be done or the materials to be furnished which may be made pursuant to the terms of said Contract shall not in any way release either the Contractor or the surety thereunder nor shall any extensions of time granted under the provisions of said Contract release either the Contractor or the surety, and notice of such alterations or extensions of the Contract is hereby waived by the surety.

WITNESS our hands this _____ day of _____, 2025.

Contractor

BY: _____

(Seal)

Title

APPROVED:

Surety

BY: _____

(Seal)

Mailing Address of Surety:

Telephone Number of Surety

(Use of City form is required)

SUPPLEMENTAL INFORMATION TO BE COMPLETED BY PRINCIPAL

If an individual, so state. If a firm or co-partnership, state the firm and give the names of all individual co-partners composing the partnership. If a Corporation, state legal name of corporation; state also the names of the president, secretary, treasurer and manager thereof.

Business Address:

Telephone Number:

Date:

Print Name:

Principal

Signature:

Title

(Use of City form is required)

TAX IDENTIFICATION NUMBER

The Tax Equity and Fiscal Responsibility Act of 1982 requires the payer (City of La Habra) to report to the Internal Revenue Service taxable payments to payees.

You (as a payee) are required by law to provide us with your Taxpayer Identification Number (if an individual or partnership, your Social Security Number). If you do not provide us with your correct identification number, you may be subject to a penalty imposed by the Internal Revenue Service. The payments subject to withholdings may include, but are not limited to, interest, dividends, or other payments the City of La Habra made to you. Other payments may include rents, royalties, commissions and fees for service of non-employees.

If you are exempt from income tax, we are still required, by law, to maintain a Tax Identification Number on file. **PLEASE PROVIDE YOUR TAX IDENTIFICATION NUMBER next to the appropriate listing below, sign, date and return to:**

CITY OF LA HABRA FINANCE DEPARTMENT
110 E. La Habra Blvd
La Habra, CA 90631

Exempt: Yes___ No___ Telephone () _____

CORPORATION: _____

U.S.A. OR ANY AGENCIES THEREOF: _____

IRS CODE #501 TAX-EXEMPT ORGANIZATION: _____

A NON-COMMISSIONED CITY OF LA HABRA EMPLOYEE: _____

SOLE PROPRIETOR: _____

A PARTNERSHIP: _____

OTHER: _____(Explain)

Signature/Title: _____ Date: _____

BID GUARANTEE

**TO THE CITY OF LA HABRA
ANNUAL SIDEWALK IMPROVEMENTS PROJECT FY24-25, CITY PROJECT NO. 1-R-25**

As a material inducement to the City to award the contract for Project No. _____ to _____, the undersigned (“Guarantor”) has agreed to enter into this guarantee. The Guarantor hereby unconditionally guarantees to the fullest extent allowed by law the following work included in this project: _____ (“the work”).

Guarantor guarantees that the materials and equipment used by itself and its subcontractors will be free from defects and that the work will conform to the plans and specifications. Should any of the materials or equipment prove defective or should the work as a whole, or any part thereof, prove defective for any reason whatsoever (except due to intentional torts by the City), or should the work as a whole or any part thereof fail to operate properly or fail to comply with the plans and specifications, Guarantor will, at the City’s sole election: 1) reimburse the City, upon written demand, for all of the City’s expenses incurred replacing or restoring any such equipment or materials, including the cost of any work necessary to make such replacement or repairs; or 2) replace any such defective material or equipment and repair said work completely, all without any cost to the City. Guarantor further guarantees that any such repair work will conform to the plans and specifications for the project. This guarantee will remain in effect for one year from the date on which the contracted for work is accepted for use by the City.

Guarantor understands and agrees that the City shall have the unqualified option to make any replacements or repairs itself or to have such replacement, repair, performed by the undersigned. The City shall have no obligation to consult with Guarantor before the City proceeds to perform any repair, replacement, or work itself. If the City elects to have Guarantor perform said repair, replacement, or work, Guarantor agrees that the repair, replacement, or work shall be performed within 15 days after receipt of a written demand from the City.

If the City elects to perform the replacement, repairs itself, Guarantor agrees to make reimbursement payment within 15 days after receipt of a written demand for payment from the City.

If the Guarantor fails or refuses to comply with this guarantee, the City shall be entitled to all costs and expenses, including attorneys and expert fees, reasonably incurred by reason of Guarantor’s failure or refusal.

Guarantor _____ Date: _____

Contractor: _____ By: _____

Title: _____

STATEMENT OF NON COLLUSION BY CONTRACTOR

The undersigned who submits herewith to the City of La Habra a bid or proposal does hereby certify:

- a. That all statements of fact in such bid or proposal are true;
- b. That such bid or proposal was not made in the interest of or on behalf of any undisclosed person, partnership, company, association, organization or corporation;
- c. That such bid or proposal is genuine and not collusive or sham;
- d. That said bidder has not, directly or indirectly by agreement, communication or conference with anyone, attempted to induce action prejudicial to the interest of the City of La Habra or of any other bidder or anyone else interested in the proposed procurement;
- e. Did not, directly or indirectly, collude, conspire, connive or agree with anyone else that said bidder or anyone else would submit a false or sham bid or proposal, or that anyone should refrain from bidding or withdraw his bid or proposal;
- f. Did not in any manner, directly or indirectly seek by agreement, communication or conference with anyone to raise or fix the bid or proposal price of said bidder or of anyone else, or to raise or fix any overhead, profit or cost element of his bid or proposal price, or that of anyone else;
- g. Did not, directly or indirectly, submit his bid or proposal price or any breakdown thereof, or the contents thereof, or divulge information or data relative thereto, to any corporation, partnership, company, association, organization, bid depository, or to any member agent thereof, or to any individual or group of individuals, except to the City of La Habra, or to any person or persons who have a partnership or their financial interest with said bidder in his business.
- h. Did not provide, directly or indirectly to any officer or employee of the City of La Habra any gratuity, entertainment, meals, or anything of value, whatsoever, which could be objectively construed as intending to invoke any form of reciprocation or favorable treatment.
- i. That no officer or principal of the undersigned firm is related to any officer or employee of the city by blood or marriage within the third degree or is employed, either full or part time, by the City of La Habra either currently or within the last two (2) years.
- j. That no officer or principal of the undersigned firm nor any subcontractor to be engaged by the principal has been convicted by a court of competent jurisdiction of any charge of fraud, bribery, collusion, conspiracy or any other act in violation of any state or federal antitrust law in connection with the bidding upon award of, or performance of, any public work contract, with any public entity, within the last three years.

I certify, under penalty of perjury under the laws of the State of California, that the foregoing is true and correct and that this certification was executed:

On _____ at _____ California.

Firm _____

(Signature)

Street _____

(Print Name & Title)

City _____ State _____ Zip _____

CERTIFICATION OF COMPLIANCE

AFFIRMATIVE ACTION REQUIREMENTS

EQUAL EMPLOYMENT OPPORTUNITY

For

**ANNUAL SIDEWALK IMPROVEMENTS PROJECT FY24-25
CITY PROJECT NO. 1-R-25**

_____ Certifies that:
(Contractor)

It has adopted and approved affirmative action plan in compliance with Title VII of the Civil Rights Act and the Equal Employment Opportunity Act of 1972 and agrees to submit a copy of that plan to the Assistant to the City Manager/Personnel of the City of La Habra for inspection prior to the award of contract.

Signed: _____

By: _____

Title: _____

Date: _____

EXHIBIT A
SCOPE OF SERVICES

EXHIBIT B
INSURANCE REQUIREMENTS

Contractor shall maintain and shall require all of its subcontractors, consultants, and other agents to maintain the insurance listed below. Any requirement for insurance to be maintained after completion of the work shall survive this agreement.

CITY reserves the right to review any and all of the required insurance policies and/or endorsements, but has no obligation to do so. Failure to demand evidence of full compliance with the insurance requirements set forth in this agreement or failure to identify any insurance deficiency shall not relieve Contractor from, nor be construed or deemed a waiver of, its obligation to maintain the required insurance at all times during the performance of this agreement.

A. Workers Compensation & Employers Liability Insurance

- Workers Compensation insurance with statutory limits as required by the Labor Code of the State of California.
- Employers Liability with limits of \$1,000,000 per Accident; \$1,000,000 Disease per employee; \$1,000,000 Disease per policy.
- The policy shall include a written waiver of the insurer's right to subrogate against CITY.
- Required Evidence Of Coverage:
 1. Subrogation waiver endorsement; and
 2. Properly completed Certificate of Insurance.

B. General Liability Insurance

- Commercial General Liability Insurance no less broad than Insurance Services Office (ISO) form CG 00 01.
- Coverage shall be on a standard occurrence form. Claims-Made forms are not acceptable without prior written consent. Modified, limited or restricted Occurrence forms are not acceptable without prior written consent.
- Minimum Limits: \$2,000,000 per Occurrence; \$4,000,000 General Aggregate; \$4,000,000 Products/Completed Operations Aggregate. The General Aggregate shall apply separately to each project. The required limits may be provided by a combination of General Liability Insurance and Commercial Excess or Umbrella Liability Insurance. If contractor maintains higher limits than the specified minimum limits, CITY requires and shall be entitled to coverage for the higher limits maintained by contractor.
- Any deductible or self-insured retention shall be shown on the Certificate of Insurance. If the deductible or self-insured retention exceeds \$25,000 it must be approved in advance by CITY. Contractor is responsible for any deductible or self-insured retention and shall fund it upon CITY'S written request, regardless of whether Contractor has a claim against the insurance or is named as a party in any action involving CITY.
- Coverage shall be continued for one (1) year after completion of the work.
- CITY shall be endorsed as an additional insured for liability arising out of ongoing and completed operations by or on behalf of the contractor. CITY shall continue to be an additional insured for completed operations for (1) year after completion of the work.
- The policy definition of "insured contract" shall include assumptions of liability

arising out of both ongoing operations and the products-completed operations hazard (“P” definition of insured contract in ISO form CG 00 01, or equivalent).

- The insurance provided to the additional insureds shall be primary to, and non-contributory with, any insurance or self-insurance program maintained by them.
- The policy shall cover inter-insured suits and include a “Separation of Insureds” or “severability” clause which treats each insured separately.
- The policy shall be endorsed to include a written waiver of the insurer’s right to subrogate against all persons or entities that are, or are required to be, additional insureds.
- The policy shall not contain a Contractors' Warranty or other similar language which eliminates or restricts insurance because of a subcontractor's failure to carry specific insurance or to supply evidence of such insurance.
- Required Evidence of Coverage:
 1. Copy of the additional insured endorsement or policy language granting additional insured status;
 2. Copy of the endorsement or policy language indicating that coverage applicable to the additional insureds is primary and non-contributory;
 3. Properly completed Certificate of Insurance; and
 4. Completed and signed Agent/Broker Questionnaire with supporting documentation as required.
 5. City of Whittier shall also be listed as additionally insured.

C. Automobile Liability Insurance

- Minimum Limit: \$2,000,000 combined single limit per accident.
- Coverage shall apply to all owned, hired and non-owned vehicles.
- CITY shall qualify as an insured.
- Required Evidence of Coverage:
 1. Copy of the endorsement or policy language indicating that CITY is an insured; and
 2. Properly completed Certificate of Insurance.
 3. City of Whittier shall also be listed as additionally insured.

D. Surety Bonds

- Bid bond.
- Performance and payment bonds for the entire contract price.
- The surety must be authorized to issue these bonds in the State of California.

E. Standards for Insurance Companies

- Insurers, other than the California State Compensation Insurance Fund, shall have an A.M. Best's rating of at least A:VII.

F. Documentation

- The Certificate of Insurance shall include the following reference: [ANNUAL SIDEWALK IMPROVEMENTS PROJECT FY24-25, PROJECT NO. 1-R-25]
- The name and address for Additional Insured endorsements and Certificates of Insurance is: City of La Habra and City of Whittier

- Contractor shall supply sufficient insurance as set forth by Caltrans and the City of Whittier at no additional cost to the City of La Habra
- Contractor shall provide immediate written notice if: (1) any of the required insurance policies is terminated; (2) the limits of any of the required policies are reduced; or (3) the deductible or self-insured retention is increased.
- Current Evidence of Coverage shall be provided for the entire required period of insurance.
- Upon written request, certified copies of required insurance policies shall be provided within thirty (30) days.

EXHIBIT C

CERTIFICATES OF INSURANCE AND ENDORSEMENTS

EXHIBIT D
CLAIMS PROCEDURE

SUMMARY OF PUBLIC CONTRACT CODE § 9204

The following procedure will apply to any claims by the Contractor on the City:

A “claim” is a separate demand on the City by a contractor on a public works project and sent by registered mail or certified mail with return receipt requested, for one or more of the following:

- A time extension, including relief from penalties for delay
- Payment by the City of money damages under the terms of the contract
- Payment of an amount that is disputed by the City

Initial Review

The claim must be supported by appropriate documentation. The City has 45 days within which to review the claim and provide the contractor with a written statement identifying the disputed and undisputed portions of the claim. If the City does not issue a written statement, the claim is deemed rejected in its entirety. The City will pay any undisputed portion of the claim within 60 days of issuing the statement.

Meet & Confer

If the contractor disputes the City’s written response, or if the City does not issue one, the contractor may request in writing an informal conference to meet and confer for possible settlement of the claim. The City will schedule the meet and confer conference within 30 days of this request and provide a written statement identifying the remaining disputed and undisputed portions of the claim within 10 business days of the meet and confer. The City will pay the undisputed portion within 60 days of issuing this statement.

Mediation

With respect to any disputed portion remaining after the meet and confer, the City and contractor will submit the matter to nonbinding mediation, agree to a mediator within 10 business days after issuing the written statement, and share mediation costs equally. If mediation is unsuccessful, then the terms of the public works agreement and applicable law will govern resolution of the dispute.

Miscellaneous Provisions

Amounts not paid by the City in a timely manner bear interest at 7% per annum. Subcontractors may submit claims via this procedure through the general contractor. The City and contractor may waive the requirement to mediate, but cannot otherwise waive these claim procedures.

APPENDIX “A”

PROJECT PLANS



STREET MAP

CITY SERVICES DIRECTORY

City Hall (B3-4)
110 E. La Habra Blvd.
(562) 383-4000

Police Department (B3-4)
150 N. Euclid St.
(562) 383-4300

Fire Department (B2-3)
850 W. La Habra Blvd.
(562) 691-4692

Public Works (C3)
621 W. Lambert Rd.
(562) 383-4170

Community Services (B3)
101 W. La Habra Blvd.
(562) 383-4200

Child Development (B3)
215 N. Euclid St.
(562) 383-4270

Children's Museum (C3)
301 S. Euclid St.
(562) 383-4236

Youth Center (A4)
441 E. Whittier Blvd. #A
(562) 383-4227

www.lahabraca.gov

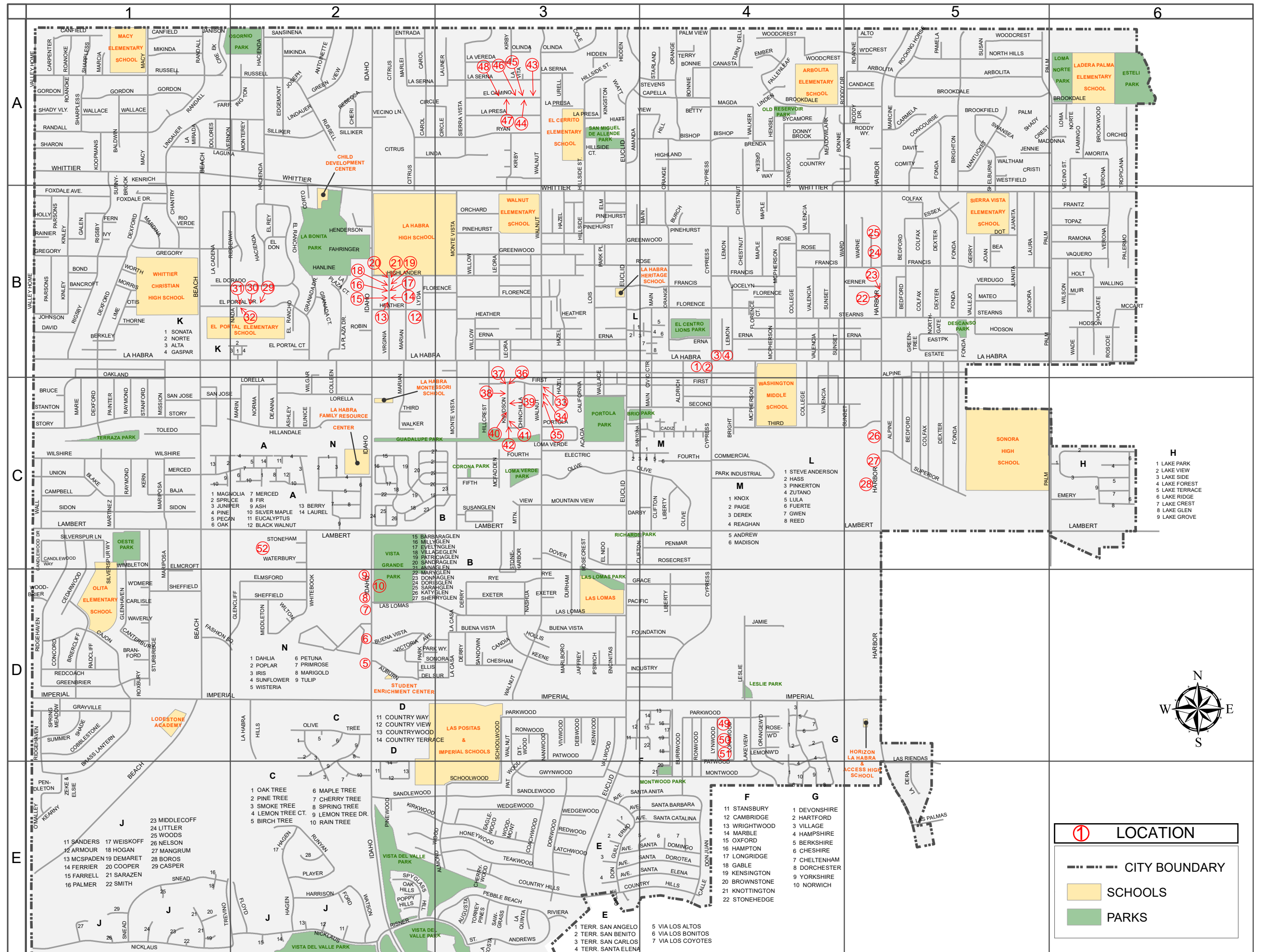

ANNUAL SIDEWALK IMPROVEMENTS PROJECT LOCATION MAP

-- A --		Carmela Lane A5	El Portal Court B2	Hensel Drive A4, B4	Latchwood Lane E3	Oak Hills Court E2	Salamanca Ct C4	-- V --	
Acacia Street C3	Carol Street A2	El Portal Drive B1, B2	Hidden Lane A3	Launer Drive A3	Laurel Street B5	Oak Tree Court D2	San Jose Avenue C1, C2	Valencia Street B4, C4	
Aldrich Street B4, C4	Carpenter Street A1	El Rancho Drive B2	Highland Court A4	Laura Street B5	Laurel Way C2	Oak Way C2	Sanders Court E2	Vallejo Street B5	
Aledo Court C4	Cartama Court C4	El Rey Drive B2	Highlander Avenue B2, B3	Lemon Street B4	Lemon Tree Court E2	Oakland Drive B1, C1	Sandlewood Ave E2, E3	Valley Home Ave A1, B1	
Alicante Court C4	Casper Court E1	Electric Avenue C3, C4	Hill Road A4	Lemon Tree Drive D2	Lemonwood Drive D4	Olinda Avenue A3	Sandown Street D3	Walwood Street D3	
Almondwood St E2, E3	Cedarwood Drive C1, D1	Elm Street B3	Hilldale Avenue C1, C2	Liberty Street C4, D4	Leslie Street D4	Olive Avenue C3, C4	Sandraglen Lane C2, C3	Vaquero Avenue B6	
Alpine Street C5	Center Lane D2	Elmcraft Circle C1	Hillcrest Street B3, C3	Lime Street B1	Orangewood Street D4, E4	Olive Tree Drive D2	Sansinena Lane A2	Vecino Lane A2	
Alta Street B2	Chantry Drive A1, B1	Elmsford Avenue D2	Hillside Court A3	Linda Avenue A2, A3	Orchard Place B3	Orange Street A4, B4	Santona Court C3	Vecino Street A6, B6	
Alto Lane A5	Charleston Avenue D2	Ellie Street A4, A5	Hillside Drive A3	Lindauer Drive A1, A2	Orchid Avenue A6	Orangewood Street D4, E4	Sarahglen Lane C2	Verdugo Avenue B5	
Amanda Lane A3, A4	Cheltenham Lane D4, E4	Ellis Court D2	Hodson Avenue B5, B6	Linden Lane A4	Otis Avenue B1	Orchard Place B3	Sarazen Court E1	Vernon Street A2	
Amorita Ave A6	Cheri Drive A2	Ember Lane A4	Hogon Avenue E1	Little Court E1	Oxford Lane D3, D4	Orchid Avenue A6	Sawgrass Court E3	Verona Street A6, B6	
Anaglen Lane C2, C3	Cherry Tree Circle E2	Emery Avenue C6	Hollis Circle D3	Lois Street B3	-- P --		Schoolwood Drive D3, E3	Via Los Altos E3, E4	
Andrew Lane C4	Cherrywood Street E3	Encinitas Street D3	Holly Avenue B1	Loma Norte Place A6	Pacific Avenue D3, D4	Palmer Court E1	Second Avenue C3, C4	Via Los Bonitos E4	
Antoinette Drive A2	Chesham Avenue D3	Entrada Drive A2	Holt Drive B6	Loma Verde Ave C3	Paige Lane C3	Park Avenue D2	Seville Court C4	Via Los Coyotes E4	
Arbolita Drive A5	Cheshire Lane D3	Erma Avenue B3, B4, B5	Honeywood Lane E2, E3	Longridge Drive D4, E4	Painter Street B1, C1	Park Industrial Drive C4	Shady Crest Lane A5	Victoria Way D2	
Armour Court E2	Chestnut Street A4, B4	Essex Drive B5	-- I --		Palermo Way B6	Park Place B3	Shady Valley Lane A1	View Drive A4, A3	
Ash Way C1, C2	Chestnut Street A4, B4	Estate Drive B5	Idaho St A2, B2, C2, D2, E2	Lorawood Street D4	Palm St A5-6, B5-6, C5-6, D5	Parkway D2	Sharon Way A1	Village Drive D4, E4	
Ashley Circle C2	Chinchilla Street C3	Eucalyptus Way C2	Imperial Hwy D1 - D5	Lorella Avenue B2, C2	Palm View A4	Parkway D2	Sharpless Street A1	Villageglen Drive C2	
Auburn Way D2	Circle Drive A2, A3	Euclid St A3, B3, C3, D3, E3, A4	Industry Avenue D3, D4	Lula Lane B4	Pamela Lane A5	Parkway D2	Sheffield Drive D1, D2	Villageglen Lane C2	
Augusta Court E3	Citrus Drive A2	Eunice Circle C2	Inola Court A6, B6	Lydia Street B2	Palmer Court E1	Parkway D2	Shelburne Street A5, B5	Virginia Street B2	
Avenida Santa Anita E3, E4	Citrus Hill Lane B3	Evelyn Lane C2	Ipswich Street D3	Lynwood Street D4	Park Avenue D2	Parkway D2	Sherryglen Lane C2, C3	Vitoria Court C3	
Avenida Santa Barbara E3, E4	Civic Center Plaza B4, C4	Exeter Avenue D3	Iris Street C2	-- M --		Parkway D2	Sidon Avenue C1	Viviwood Place D3	
Avenida Santa Catalina E3, E4	Clifton Street C4	Exeter Circle D3	Ironwood Street D4, E4	Macy Street A1	Parkwood Avenue D3, D4	Parkway D2	Sierra Vista Drive A3	-- W --	
Avenida Santa Dorotea E3, E4	Coachwood Street E3	-- F --		Madonna Lane A6	Parsons Street B1	Parkway D2	Silliker Avenue A2	Wade Street B6	
Avenida Santa Elena E3, E4	Cobblestone Road D1	Fahringer Way B2	Ivy Place B1	Madison Lane C4	Patriciaglen Lane C2	Parkway D2	Silver Maple Drive C1, C2	Walker Avenue C2	
Avenida Santo Domingo E3, E4	Cole Way A3	Fallen Leaf Street A4	-- J --		Madison Way D2	Parkway D2	Silverspur Lane C1	Walker Road A4	
Avo Lane B3	Colfax Street B5, C5	Farell Court E2	Jaffrey Street D3	Jennie Lane A5, A6	Magda Lane A4	Parkway D2	Silverspur Way C1	Wall Street C1	
-- B --		Colleen Street B2, C2	Jamie Avenue D4	Joan Street B5	Magnolia Way C2	Parkway D2	Smith Court E1	Wallace Avenue A1	
Baja Avenue C1	College Street B4, C4	Farrington Drive A1, A2	Jamie Avenue D4	Jocelyn Avenue B4	Main Street B4, C4	Parkway D2	Smoke Tree Court D2, E2	Wallace Street B3, C3	
Baja Court C4	Comity Circle A5	Fashion Square Ln D1	Jennette Lane A5, A6	Johnson Avenue B1	Mangrum Court E1	Parkway D2	Smoke Tree Drive D2, E2	Walling Avenue B6	
Baldwin Street A1	Commercial Way C4	Fern Way B1	Joan Street B5	Joseph Court A2	Maple Street B4	Parkway D2	Snead Street E1	Walnut Street A3, B3, C3, D3, E3	
Bancroft Avenue B1	Concord Way D1	Fifth Avenue C3	Joan Street B5	Juanita Street B5	Maple Tree Court D2	Parkway D2	Sonata Street B2	Waltham Way A5	
Barbaraglen Lane C2	Concourse Street A5, B5	Fir Way C2	Juniper Way C2	Katyglen Lane C2	Marble Lane D4	Parkway D2	Sonora Avenue D2, D3	Ward Street B5	
Bea Way B5	Cooper Court E1	First Avenue B3, C3, C4	Kearny Lane E1	Keene Drive D3	Marcia Drive A1	Parkway D2	Sonora Place B5	Warne Street B5	
Beach Blvd A1, B1, C1, D1, E1	Cordoba Court C4	Florence Avenue B2, B3, B4	Keene Drive D3	Kenrich Court A1	Marcine Street A5	Parkway D2	Spring Meadow Lane D1	Waterbury Way C2	
Beach Street A1	Corto Way A2, B2	Florence Avenue B3	Mardina Way B1	Kensington Lane D4	Mardina Way B1	Parkway D2	Spring Tree Court D2	Watson Street E2	
Bedford Street B5, C5	Costa Blanca Court C4	Florence Court B4	Marian Street B2, C2	Kenwood Street D3	Marie Street B1, C1	Parkway D2	Spruce Way C1	Waverly Terrace D1	
Berkley Avenue B1	Costa Blanca Ave C4	Florence Court B4	Marigold Avenue C2	Kern Street C1	Marigold Avenue C2	Parkway D2	Pinewood Place E2, E3	Wedgewood Lane E3	
Berkshire Lane D4	Country Hills Drive E3, E4	Floyd Court E1, E2	Marin Street B2, C2	Kerner Way B5	Marion Street B2, C2	Parkway D2	St. Andrews Ave E2, E3	Weiskoff Court E2	
Berry Way C1	Country Lane A4	Fonda Street A5, B5, C5	Mariposa Street C1, D1	Kingston Drive A3	Mariposa Street C1, D1	Parkway D2	Stanford Street B1, C1	Westfield Way A5	
Betty Lane A4	Country Terrace D2	Ford Court E2	Marlboro Street D3	Knox Drive C3, C4	Marlboro Street D3	Parkway D2	Stansbury Lane D3, D4	Whitebook Drive C2, D2	
Birch Tree Court D2	Country View E2	Foundation Avenue D3, D4	Martinez Drive C1	Kirkwood Lane E2, E3	Marlei Road A2	Parkway D2	Stanton Avenue C1	Whittier Blvd A1-3, B2-6	
Bishop Drive A4	Country Way D2, E2	Fourth Avenue C3, C4	Maryglen Lane C2, C3	Kirkwood Lane E2, E3	Martinez Drive C1	Parkway D2	Starland Street A4	Wiatt Way A3	
Black Walnut Way C2	Countrywood D2, E2	Foxdale Avenue B1	Mateo Avenue B5	Knottington Lane E4	Maryglen Lane C2, C3	Parkway D2	Stearns Avenue B4, B5, B6	Wilgar Drive B2, C2	
Blake Street C1	Creek Lane A1, A2	Francis Avenue B3, B4, B5	McCart Avenue B6	Knox Drive C3, C4	Mateo Avenue B5	Parkway D2	Steve Anderson Pl B3, B4	Willow Street B3	
Bond Avenue B1	Cristi Lane A5, A6	Frantz Avenue B6	McFadden Street C3	Koopmans Way A1	McCart Avenue B6	Parkway D2	Stevens Avenue A4	Wilshire Avenue C1	
Bonnie Ann Court A4, A5	Cypress Street A4, B4, C4, D4	Fuerte Lane B4	McPherson Street B4	-- K --		Parkway D2	Stone Harbor Circle C3	Wilson Street B6	
Bonnie Lane A4	-- D --		McSpaden Court E2	La Cadena Way B1	Meadow Lark Street A4	Parkway D2	Stoneham Way C2	Wilton Way D2	
Boros Court E2	Dahlia Street C2	Gable Lane D4	Meadow Lark Street A4	La Casa Avenue D3	Merced Avenue C1, C2	Parkway D2	Stonewood Lane D3	Wimbleton Lane C1	
Branford Lane D1	Darby Court C3, C4	Galen Drive B1	Merced Avenue C1, C2	La Costa Court E3	Middlecoff Court E1	Parkway D2	Stonewood Street A4, B4	Wisteria Avenue C2	
Brass Lantern Drive D1, E1	Daffodil Avenue C2	Gaspar Street B2	Middlecoff Court E1	La Habra Blvd B1-6	Middleton Street D2	Parkway D2	Story Avenue C1	Woodbrier Drive D1	
Brenda Lane A4	David Avenue B1	Gerry Street B5	Middleton Street D2	La Habra Hills Dr D2	Mikinda Avenue A1, A2	Parkway D2	Sturbridge Drive C1, D1	Woodcrest Avenue A4, A5	
Bridenbecker Ave C3, C4	Davit Circle A5	Glenciff Street D1, D2	Mikinda Avenue A1, A2	La Mirada Street A1	Millglen Lane C2	Parkway D2	Summershade Dr D1	Woodmere Circle D1	
Briercliff Drive D1	Deanna Street B2, C2	Glenhaven Drive C1, D1	Millglen Lane C2	La Plaza Court B2	Mission Street B1, C1	Parkway D2	Sunflower Avenue C2	Woodmont Place E3	
Bright Street C4	Debwood Place D3	Gordon Avenue A1	Mission Street B1, C1	La Plaza Drive B2	Monte Vista Street B3, C3	Parkway D2	Sunnybrook Drive A1, B1	Woods Court E1	
Brighton Street A5, B5	Del Sur Avenue D2, D3	Grace Avenue D3, D4	Monte Vista Street B3, C3	La Presa Drive A3	Monterey Street A2	Parkway D2	Sunset Street B4	Worth Avenue B1	
Brookdale Avenue A4, A5, A6	Demaret Court E1	Granada Court B2	Monterey Street A2	La Quinta Court E3	Montwood Avenue E3, E4	Parkway D2	Superior Avenue C5	Wrightwood Drive D3, D4	
Brookfield Avenue A5	Derek Lane C3	Granada Drive B2	Montwood Avenue E3, E4	La Serna Avenue A2, A3	Morris Street B1	Parkway D2	Susan Lane A5	-- Y --	
Brookwood Drive A6	Derry Street D3	Grayville Drive D1	Morris Street B1	La Vereda Drive A3	Mountain View Ave C3	Parkway D2	Susanglen Circle C3	-- Z --	
Brownstone Drive D4, E4	Devonshire Lane D4, E4	Greenbrier Lane D1	Mountain View Ave C3	La Vita Place A3	Muir Way B6	Parkway D2	Swansea Circle A5	Zeke & Elsie Ave E1	
Bruce Lane C1	Dexford Drive B1, C1	Greentree Lane B5	Muir Way B6	Ladera Terrace E5	Murcia Court C4	Parkway D2	Sycamore Avenue A4	Zutano Lane B4	
Buena Vista Ave D2, D3	Dexter Street B5, C5	Greenview Drive A2	-- L --		-- R --				
Burch Way B4	Ditwood Place D3	Greenway Terrace A4	La Cadena Way B1	Laguna Drive A1, A2	Radcliff Place D1	Parkway D2			
Burwood Street D4, E4	Dolores Street A1	Greenwood Avenue B3, B4	La Casa Avenue D3	Lake Crest Lane C6	Rain Tree Drive D2, E2	Parkway D2			
-- C --		Donnaglen Lane C2, C3	La Costa Court E3	Lake Forest Circle C6	Rainier Way B1	Parkway D2			
Cadiz Court C4	Donnybrook Ave A4	Gregory Lane B1, B2	La Habra Blvd B1-6	Knudson Street C3	Ramona Avenue B6	Parkway D2			
Cajon Drive D1	Dorchester Lane E4	Gwen Lane B4	La Habra Hills Dr D2	Koopmans Way A1	Randall Avenue A1	Parkway D2			
California Street B3, C3	Dorisglen Lane C2, C3	Gwynwood Avenue E3	La Habra Blvd B1-6	-- M --		Parkway D2			
Calle Don Guillermo E3	Dorwood Avenue E3	-- H --		La Merced Ave C1, C2	Raymond Street B1, C1	Parkway D2			
Calle Don Juan E4	Dot Avenue B5	Hacienda Drive B2	La Merced Ave C1, C2	Middlecoff Court E1	Reagan Lane C4	Parkway D2			
Cambridge Drive D3	Dover Drive C3	Hacienda Road A2, B2	Middlecoff Court E1	Middleton Street D2	Rebecca Drive A2	Parkway D2			
Campbell Avenue C1	Doves Nest Avenue A4, A5	Hagen Street E2	Middleton Street D2	Mikinda Avenue A1, A2	Red Coach Lane D1	Parkway D2			
Canasta Drive A4	Durham Street C3, D3	Hampshire Lane D4, E4	Mikinda Avenue A1, A2	Millglen Lane C2	Redwood Lane E3	Parkway D2			
Candace Lane A5	-- E --		Millglen Lane C2	Mission Street B1, C1	Reed Lane B4	Parkway D2			
Candia Circle D3	Eaglewood Place E3	Harrison Avenue E2	Mission Street B1, C1	Monte Vista Street B3, C3	Ridgehaven Drive C1, D1	Parkway D2			
Candlewood Drive C1	Eastpark Drive B5	Hartford Lane D4	Monte Vista Street B3, C3	Monterey Street A2	Ridgeway Lane B2	Parkway D2			
Candlewood Way C1	Edgemont Street A2	Hass Lane B3	Monterey Street A2	Morris Street B1	Rigsby Street A1, B1	Parkway D2			
Canfield Drive A1	Edwards Drive C5	Hazel Street B3, C3	Morris Street B1	Mountain View Ave C3	Rio Verde Drive B1	Parkway D2			
Canterbury Lane D1	El Camino Drive A3	Heather Avenue B2, B3	Mountain View Ave C3	Muir Way B6	Risner Way B2	Parkway D2			
Cantabria Court C4	El Don Drive B2	Heather Way B3	Muir Way B6	Murcia Court C4	Riviera Court E3	Parkway D2			
Capella Avenue A3, A4	El Dorado Avenue B1, B2	Henderson Way B2	Murcia Court C4	-- N --		Parkway D2			
Carlisle Circle D1	El Nido Street C3	-- O --		Nada Street B2	Roscoe Street B6	Parkway D2			
				Nantucket Street A5	Rose Avenue B3, B4	Parkway D2			
				Nanwood Street D3	Rosecrest Avenue C3, C4	Parkway D2			
				Nashua Street D3	Rosewood Lane D4	Parkway D2			
				Nicklaus Avenue E1, E2	Roxbury Terrace D1	Parkway D2			
				Nelson Court E1	Runyan Street E2	Parkway D2			
				Norma Street C2	Russell Street A1, A2	Parkway D2			
				Norte Street B1, B2	Ryan Avenue A2, A3	Parkway D2			
				North Hills Drive A5	Rye Avenue D3	Parkway D2			
				Northgate Way B5	Rye Circle D3	Parkway D2			
				Norwich Lane E4	-- S --				
				O'Malley Lane E1					

APPENDIX “B”

STANDARD PLANS

- SPPWC 110-2 – DRIVEWAY APPROACHES
- SPPWC 112-2 – CURB AND SIDEWALK JOINTS
- SPPWC 120-3 – CURB AND GUTTER - BARRIER
- SPPWC 518-4 – TREE STAKING
- SPPWC 520-5 – TREE PLANTING

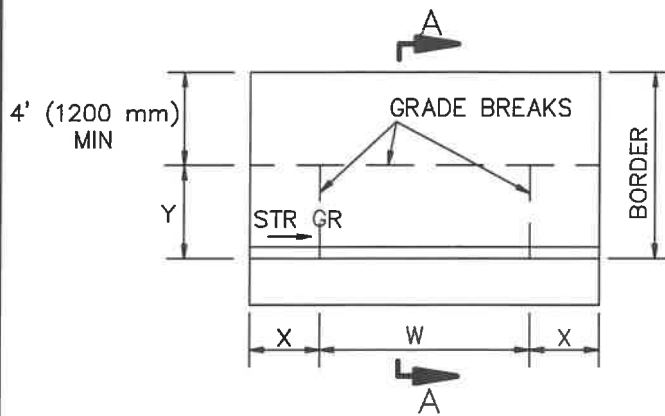

TYPE A

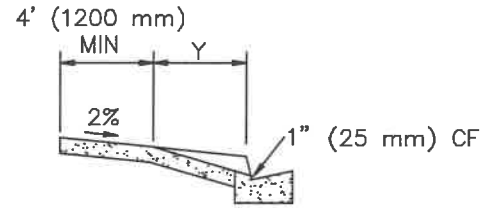

SECTION A-A

CURB FACE, inches (mm)	X, inches (mm)	Y, inches (mm)
6" (150) or less	3'-0" (900)	4'-0" (1200)
7" (175)	3'-6" (1050)	4'-9" (1425)
8" (200)	4'-0" (1200)	5'-8" (1700)
9" (225)	4'-6" (1350)	6'-6" (1950)
10" (250)	5'-0" (1500)	7'-3" (2175)
11" (275)	5'-6" (1650)	8'-0" (2400)
12" (300) or more	6'-0" (1800)	8'-9" (2625)

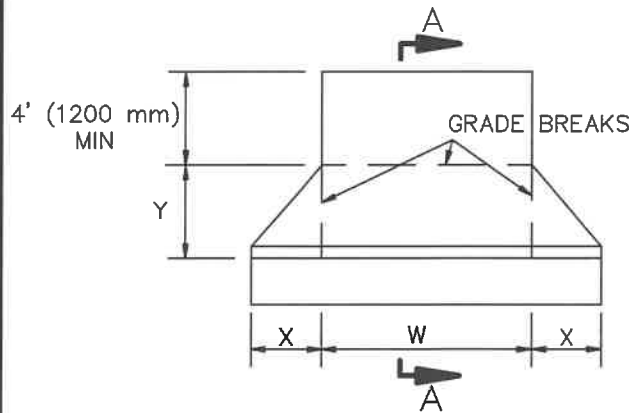

TYPE B

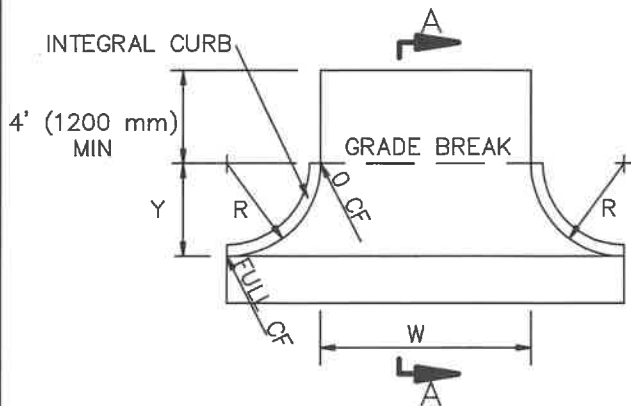

TYPE C

NOTES:

1. RESIDENTIAL DRIVEWAYS SHALL BE 4" (100 mm) THICK PCC.
2. COMMERCIAL DRIVEWAYS SHALL BE 6" (150 mm) THICK PCC.
3. WEAKENED PLANE JOINTS SHALL BE INSTALLED AT BOTH SIDES OF A DRIVEWAY AND AT 10' (3.0 m) INTERVALS.
4. CURB FOR TYPE C DRIVEWAY SHALL BE INTEGRAL AND MATCH ADJACENT CONSTRUCTION.
5. REFER TO LOCAL DEVELOPMENT REGULATIONS FOR AMERICANS WITH DISABILITIES ACCESS REQUIREMENTS AND MAXIMUM PERMITTED DRIVEWAY WIDTHS.

STANDARD PLANS FOR PUBLIC WORKS CONSTRUCTION

PROMULGATED BY THE
PUBLIC WORKS STANDARDS INC.
GREENBOOK COMMITTEE
1984
REV. 1996, 2009

DRIVEWAY APPROACHES

USE WITH STANDARD SPECIFICATIONS FOR PUBLIC WORKS CONSTRUCTION

STANDARD PLAN

110-2

SHEET 1 OF 1

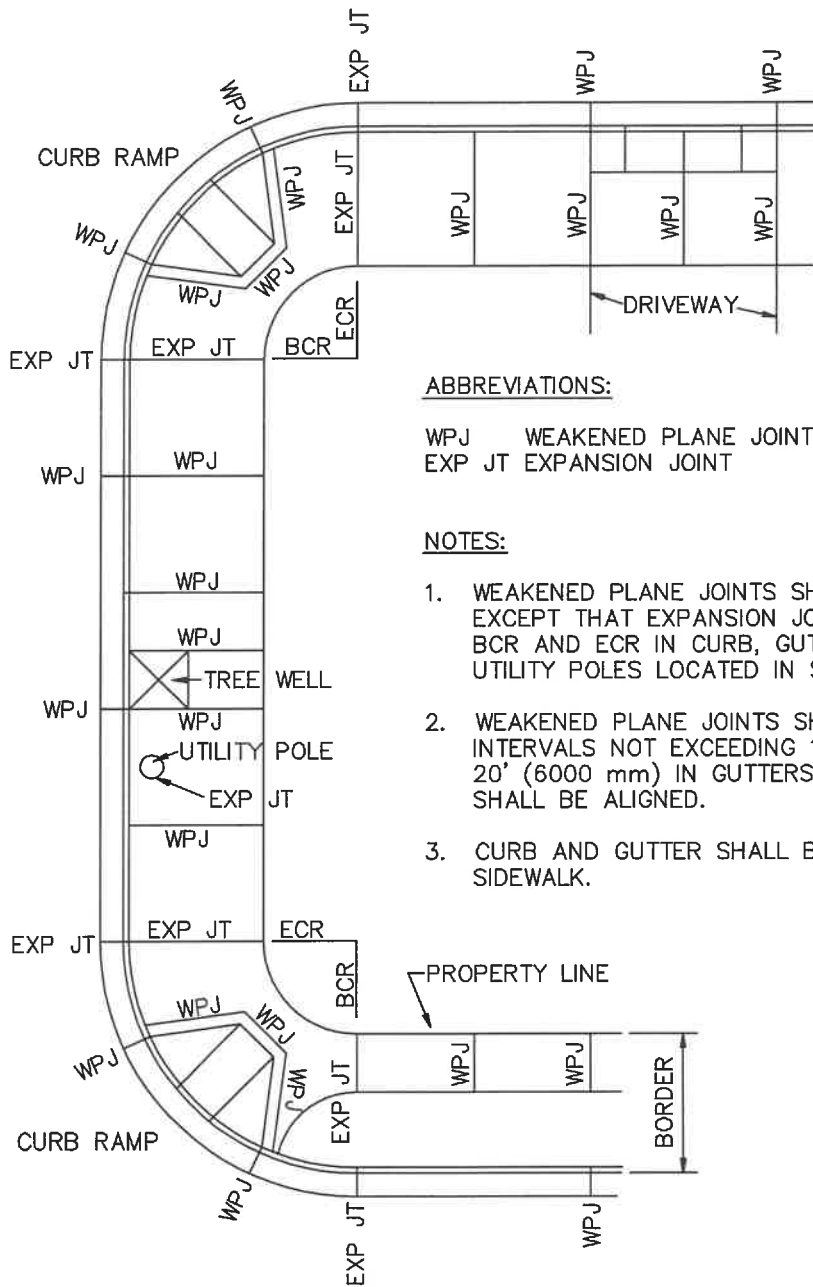

ABBREVIATIONS:

WPJ WEAKENED PLANE JOINT BCR BEGINNING OF CURB RETURN
 EXP JT EXPANSION JOINT ECR END OF CURB RETURN

NOTES:

1. WEAKENED PLANE JOINTS SHALL BE USED FOR ALL JOINTS, EXCEPT THAT EXPANSION JOINTS SHALL BE PLACED AT THE BCR AND ECR IN CURB, GUTTER AND SIDEWALK, AND AROUND UTILITY POLES LOCATED IN SIDEWALK AREAS.
2. WEAKENED PLANE JOINTS SHALL BE CONSTRUCTED AT REGULAR INTERVALS NOT EXCEEDING 10' (3000 mm) IN WALKS AND 20' (6000 mm) IN GUTTERS. JOINTS IN CURB AND WALK SHALL BE ALIGNED.
3. CURB AND GUTTER SHALL BE CONSTRUCTED SEPARATELY FROM SIDEWALK.

STANDARD PLANS FOR PUBLIC WORKS CONSTRUCTION

PROMULGATED BY THE
 PUBLIC WORKS STANDARDS INC.
 GREENBOOK COMMITTEE
 1984
 REV. 1996, 2009

CURB AND SIDEWALK JOINTS

USE WITH STANDARD SPECIFICATIONS FOR PUBLIC WORKS CONSTRUCTION

STANDARD PLAN

112-2

SHEET 1 OF 1

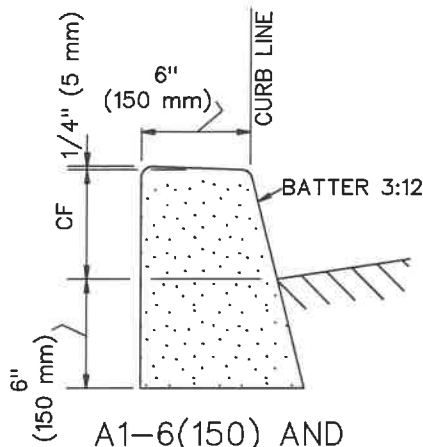

A1-6(150) AND
A1-8(200)

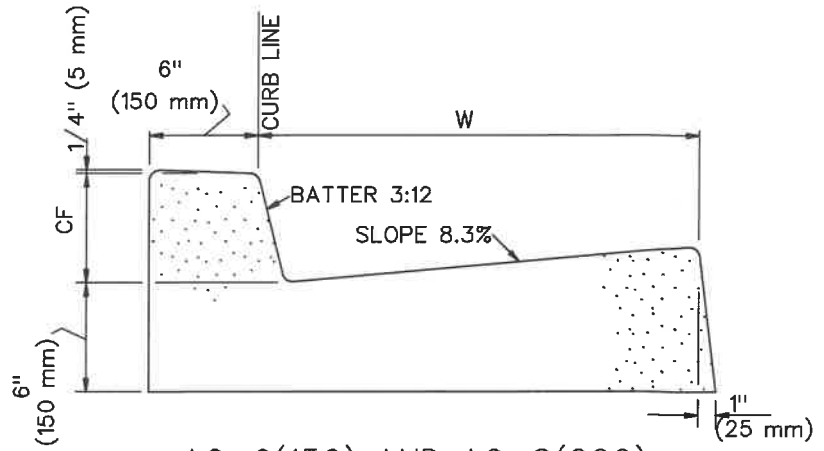

A2-6(150) AND A2-8(200)

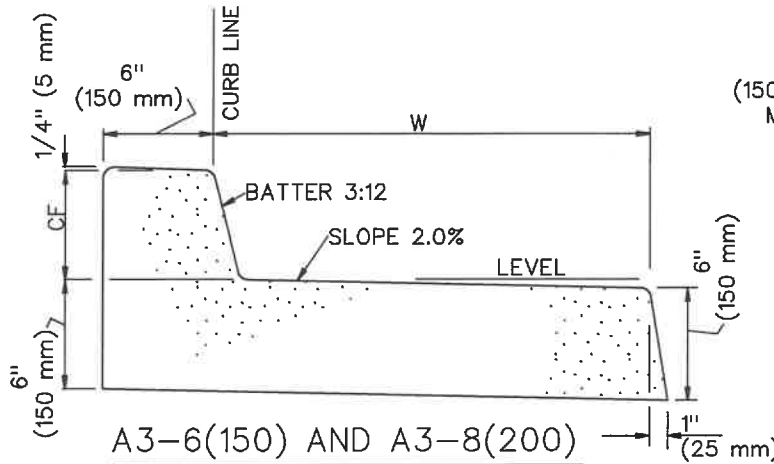

A3-6(150) AND A3-8(200)

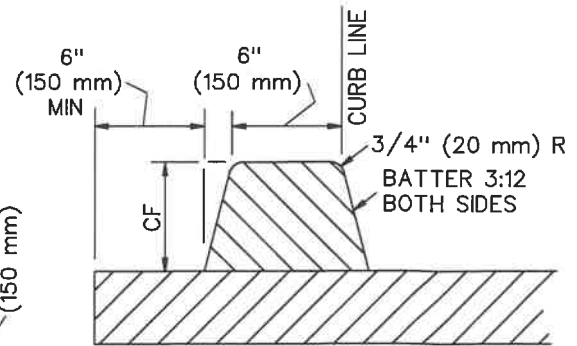

D1-6(150) AND
D1-8(200)

NOTES:

1. THE LAST NUMBER IN THE DESIGNATION IS THE CURB FACE (CF) HEIGHT, INCHES (mm). IF SHOWN AS 'VAR' THE CURB FACE VARIES.
2. GUTTER WIDTH, W, IS 24" (600 mm) UNLESS OTHERWISE SPECIFIED.
3. TYPES A1, A2, A3 AND C1 SHALL BE CONSTRUCTED OF CONCRETE.
4. TYPE D1 CURB SHALL BE CONSTRUCTED OF ASPHALT CONCRETE.
5. TYPE C1 CURB SHALL BE ANCHORED WITH STEEL DOWELS AS SHOWN OR WITH AN EPOXY APPROVED BY THE ENGINEER.
6. ALL EXPOSED CORNERS ON CONCRETE CURBS AND GUTTERS SHALL BE ROUNDED WITH A 1/2" (15 mm) RADIUS.

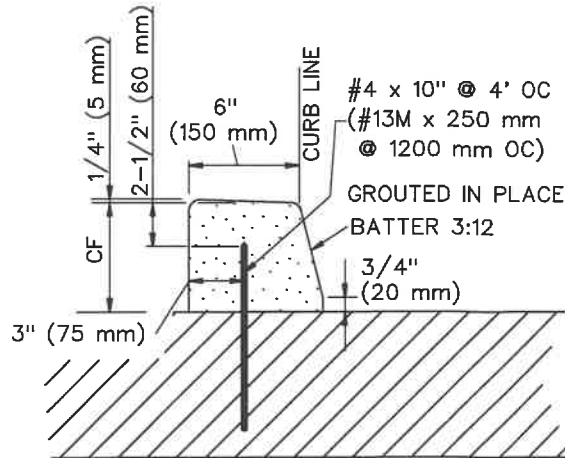

C1-6(150) AND C1-8(200)

STANDARD PLANS FOR PUBLIC WORKS CONSTRUCTION

PROMULGATED BY THE
PUBLIC WORKS STANDARDS INC.
GREENBOOK COMMITTEE
1984
REV. 1986, 2009, 2021

CURB AND GUTTER - BARRIER

USE WITH STANDARD SPECIFICATIONS FOR PUBLIC WORKS CONSTRUCTION

STANDARD PLAN

120-3

SHEET 1 OF 1

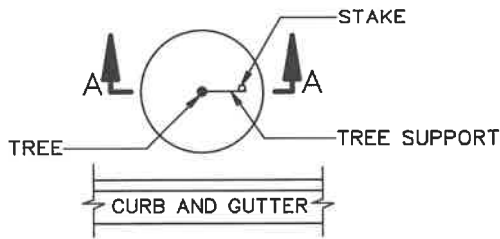

PLAN

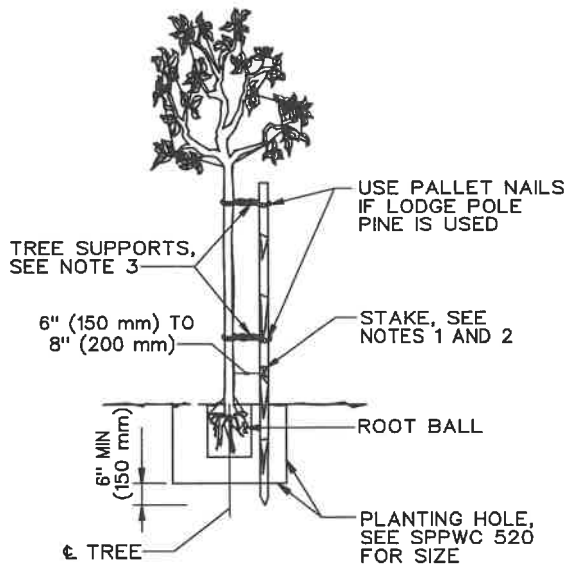

SECTION A-A

SINGLE STAKING

NOTES:

1. STAKE SHALL BE EITHER 2" (50 mm) DIAMETER LODGE POLE PINE TREATED WITH COPPER NAPHTHANATE OR PRESSURE TREATED WITH CHROMATED COPPER ARSENATE, OR GALVANIZED STEEL PIPE PER SSPWC 801-4.6.1 (METHOD A).
2. HEIGHT OF STAKE SHALL BE 10' (3 m); HOWEVER, IT SHALL NOT BE HIGHER THAN THE TOP OF THE TREE.
3. TREE SUPPORTS SHALL BE PER SSPWC 801-4.6.1.

STANDARD PLANS FOR PUBLIC WORKS CONSTRUCTION

PROMLGATED BY THE
PUBLIC WORKS STANDARDS INC.
GREENBOOK COMMITTEE
1984
REV. 1998, 2006, 2009, 2021

TREE STAKING

STANDARD PLAN

518-4

USE WITH STANDARD SPECIFICATIONS FOR PUBLIC WORKS CONSTRUCTION

SHEET 1 OF 3

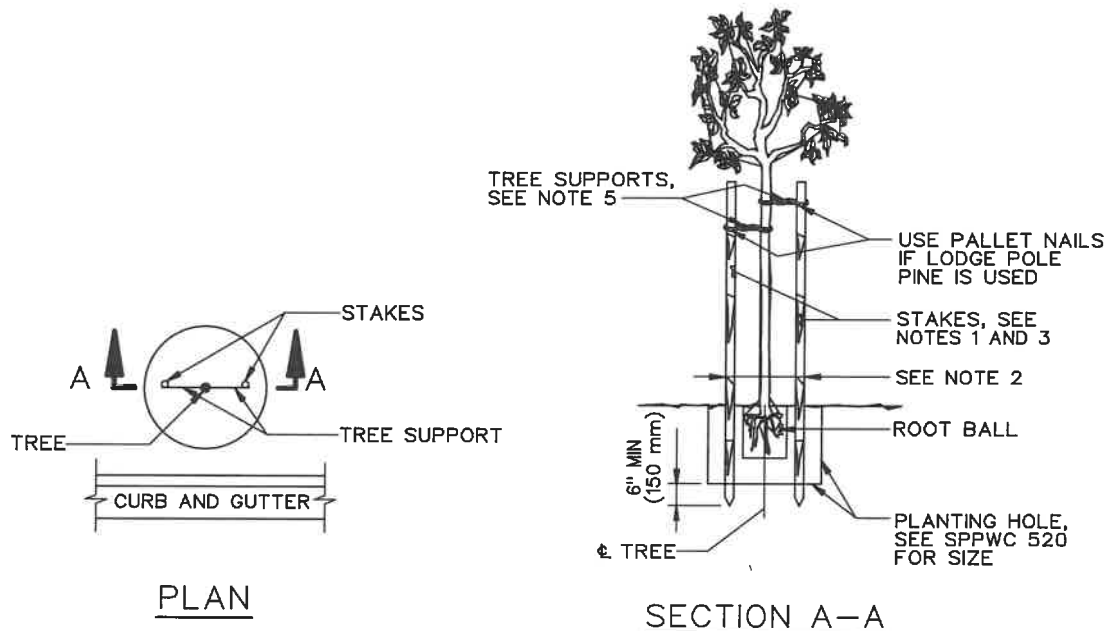

LENGTH OF STAKES	
TREE SIZE	LENGTH
15 GAL (55 L)	10' (3 m)
24" (600 mm) BOX	12' (3.6 m)
30" (750 mm) BOX	12' (3.6 m)
36"-48" (900 - 1200 mm) BOX	SEE NOTE 4

DOUBLE STAKING

NOTES:

1. STAKE SHALL BE EITHER 50 mm (2") DIAMETER LODGE POLE PINE, TREATED WITH COPPER NAPHTHANATE OR PRESSURE TREATED WITH CHROMATED COPPER ARSENATE, OR GALVANIZED STEEL PIPE, PER SSPWC 801-4.6.1 (METHOD A).
2. PLACE STAKES 18" (450 mm) APART FOR 15 GAL (55 L) TREE. PLACE STAKES AT OUTER EDGE OF ROOT BALL FOR LARGER SIZE (BOX) TREES.
3. HEIGHT OF STAKES SHALL NOT BE HIGHER THAN THE TOP OF THE TREE.
4. FOR 36" (900 mm) OR LARGER BOX TREES: STAKE OR GUY AT THE DIRECTION OF THE ENGINEER.
5. TREE SUPPORTS SHALL BE PER SSPWC 801-4.6.1.

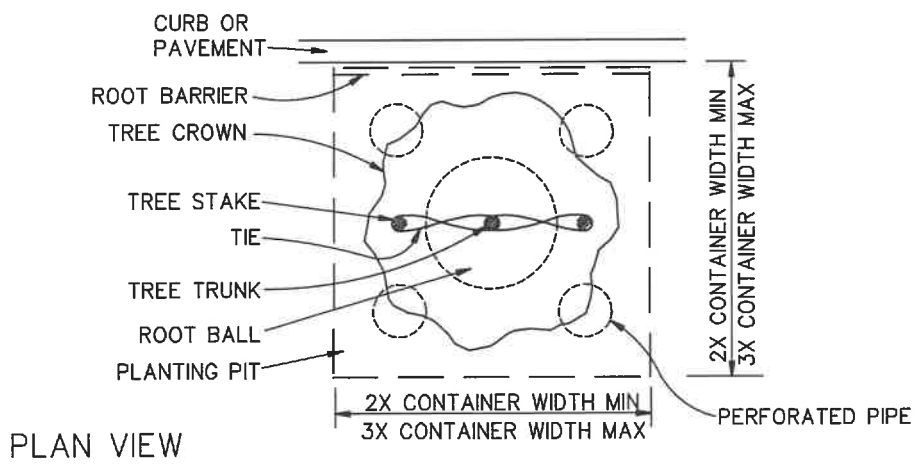
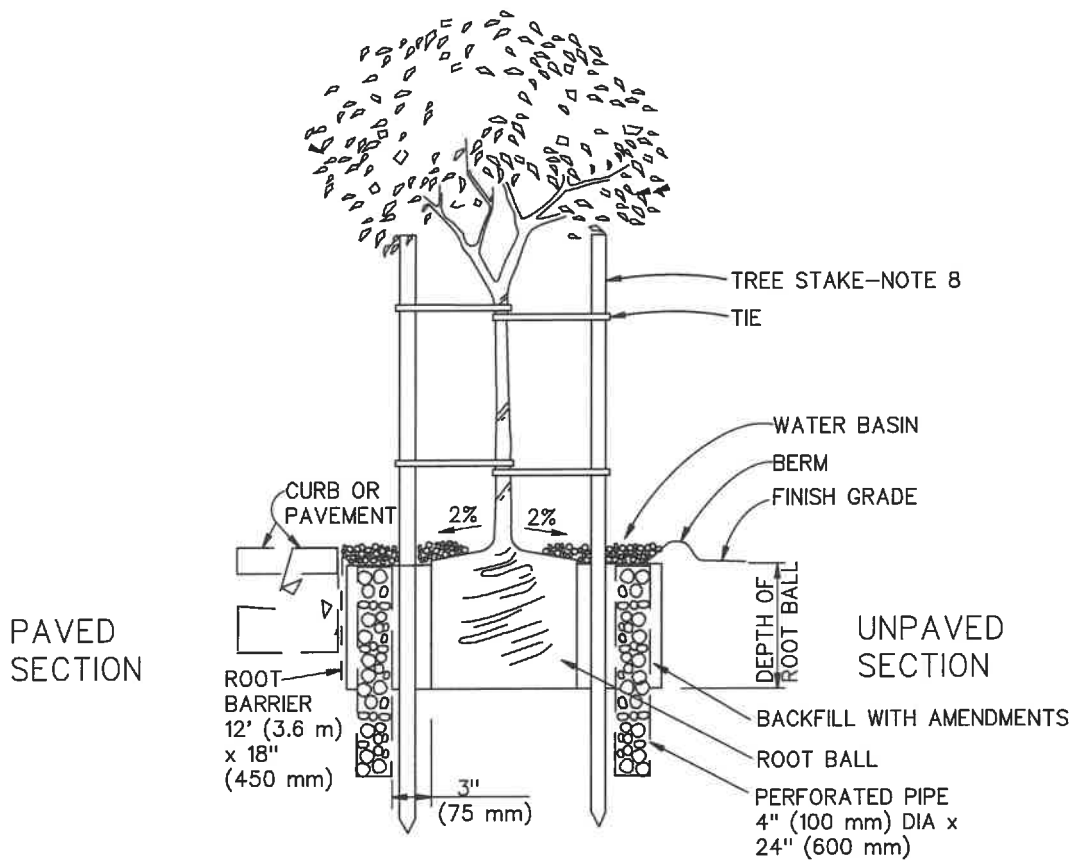

UNPAVED PARKWAY
15 GAL (55 L) OR 24" (600 mm) BOX

STANDARD PLANS FOR PUBLIC WORKS CONSTRUCTION

PROMULGATED BY THE
PUBLIC WORKS STANDARDS INC.
GREENBOOK COMMITTEE
1984
REV. 1993, 1996, 2005, 2009, 2021

TREE PLANTING

STANDARD PLAN

520-5

USE WITH STANDARD SPECIFICATIONS FOR PUBLIC WORKS CONSTRUCTION

SHEET 1 OF 4

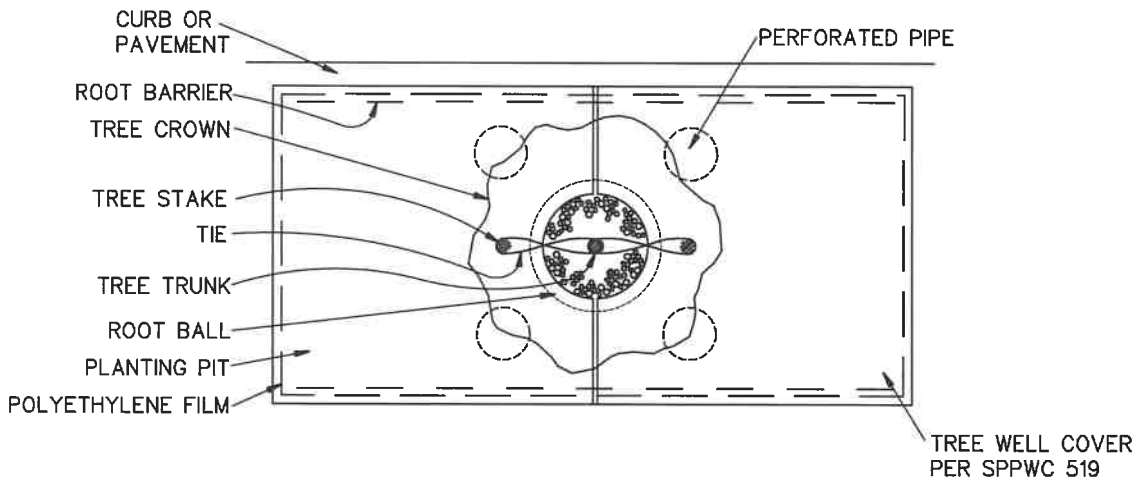
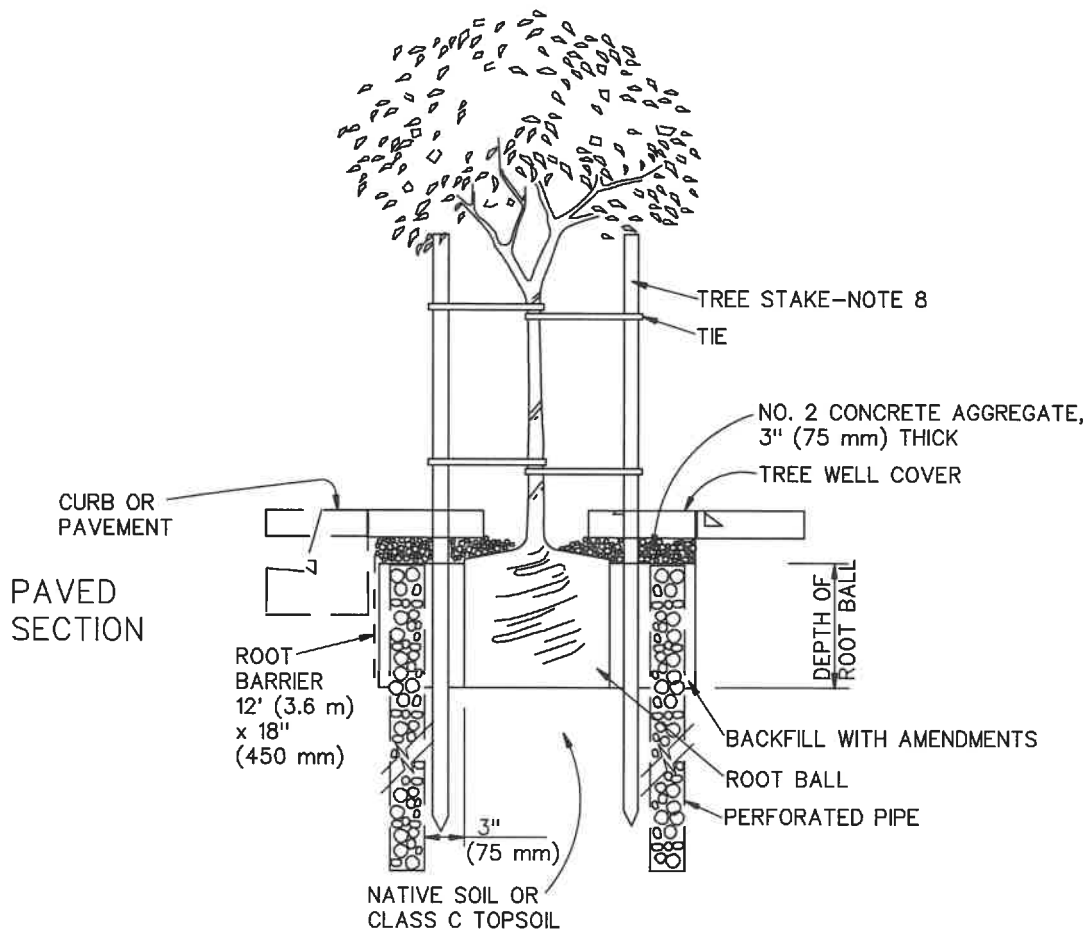

PLAN VIEW

SIDEWALK TREE WELL
15 GAL (55 L) OR 24" (600 mm) BOX

SECTION

ROOT BARRIER
16' (4800 mm)
x 36" (900 mm)

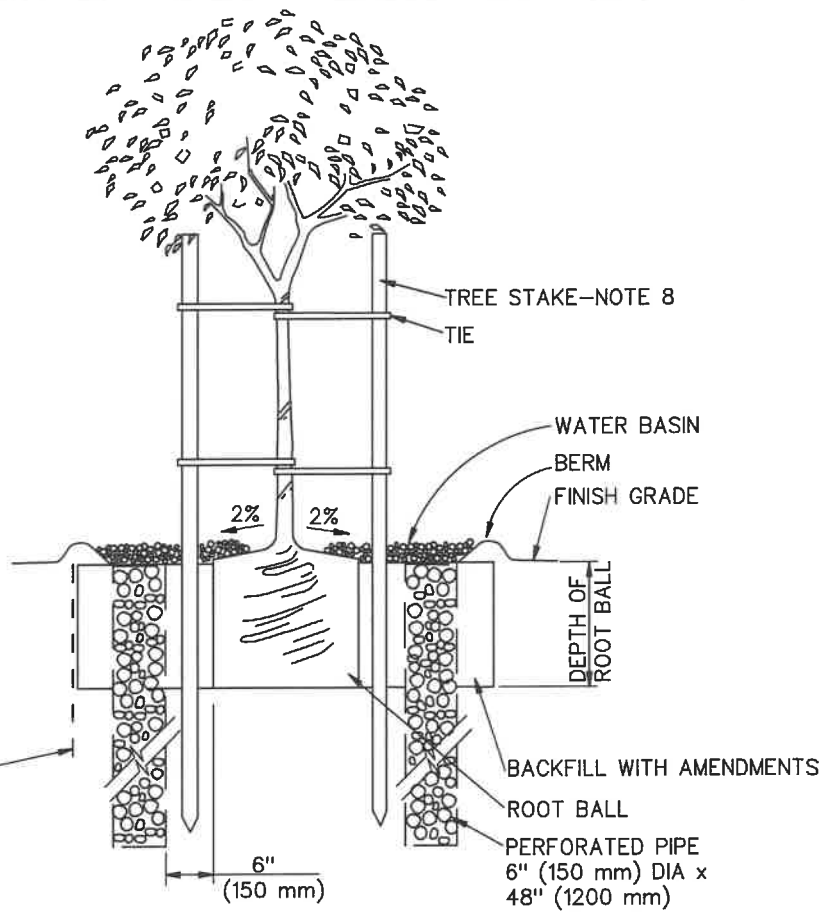

PLAN VIEW

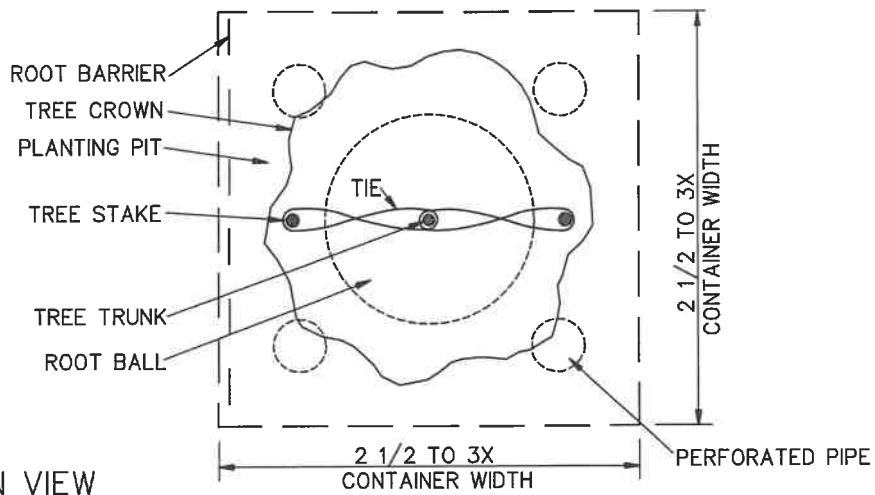

30" (750 mm) TO 48" (1200 mm) BOX

NOTES:

1. SET TOP OF ROOT BALL 1" (25 mm) ABOVE FINISH GRADE.
2. FOR 24" (600 mm) BOX TREES OR SMALLER, INSTALL ROOT BARRIERS IF TRUNK IS WITHIN 5' (1.5 m) OF CURB OR WALK.
FOR 30" TO 48" (750 TO 1200 mm) BOX TREES, INSTALL ROOT BARRIERS IF TRUNK IS WITHIN 10' (3.0 m) OF CURB OR WALK.
3. AMEND BACKFILL MIX PER SPECIFICATIONS. LEAVE TRUNK AND ROOT FLARE VISIBLE.
4. SET PERFORATED PIPE FLUSH WITH TOP OF BACKFILL. FILL PIPE WITH NO. 2 CONCRETE AGGREGATE PER SSPWC TABLE 200-1.4 (B) AND COVER WITH FILTER FABRIC. WRAP FABRIC 6" (150 mm) DOWN SIDES OF PIPE.
5. FORM 3 1/2" (90 mm) HIGH BERM AROUND BACKFILL AS A WATER BASIN.
6. TOP WATER BASIN WITH 3 1/2" (90 mm) OF NO. 2 CONCRETE AGGREGATE OR TYPE 1 MULCH PER THE SPECIAL PROVISIONS. KEEP CONCRETE AGGREGATE OR MULCH 3 1/2" (90 mm) CLEAR OF TRUNK. LEAVE TRUNK AND ROOT FLARE VISIBLE.
7. REMOVE ALL NURSERY STAKES.
8. INSTALL NEW TREE STAKES PER SPPWC 518.
9. FASTEN TREE TO STAKES PER 801-4.6, TWO TIES PER STAKE.
10. AFTER PLANTING, PRUNE THE TREE AS APPROVED BY THE ENGINEER.
11. POLYETHYLENE FILM, WHERE SHOWN, SHALL BE 6 MIL (0.15 mm) THICK. LINE ALL FOUR SIDES OF PLANTING PIT.

APPENDIX “C”
LIST OF QUANTITIES

CITY OF LA HABRA

SIDEWALK AND CURB RAMP IMPROVEMENTS PROJECT

LIST OF QUANTITIES

Item No.	Address No.	Street Address	From	To	Location	R/R Concrete Walkway with Detectable Warning Surface	R/R Sidewalk	R/R Drive Approach (6 in)	R/R Private Walkway (4 in)	R/R Curb and Gutter (G = 24 in., CF = 8in.)	Private Parking Lot Striping	Remove Street Tree, 12 in. dia.	Remove Street Tree, 18 in. dia.	Remove Street Tree, 24 in. dia.	Plant Street Tree, 24 in. box tree	Install Root Barrier
1	362	E La Habra Blvd	Aldrich Street	Cypress Street			96									
2	374	E La Habra Blvd	Aldrich Street	Cypress Street			9									
3	409	E La Habra Blvd	Cypress Street	Lemon Street			144	224			1					
4	405	E La Habra Blvd	Cypress Street	Lemon Street				272			1					
5		East Side Idaho Street	951 Idaho Street Driveway	Imperial Hwy			1250						2		2	2
6		East Side Idaho Street	Las Lomas Dr	951 Idaho Street Driveway			500					2			2	2
7		East Side Idaho Street	Village Green Apt Driveway	Las Lomas Dr			550			15			2		2	2
8		East Side Idaho Street	Woodlake Village Driveway	Village Green Apt Driveway			325									
9		East Side Idaho Street	Village Green Apt Driveway	Lambert Road			800		20				3		3	3
10		West Side Idaho Street	Lambert Road	Las Lomas Dr			68									
11		West Side Idaho Street	Las Lomas Dr	Exit Driveway to La Habra Knolls			160									
12	920	Heather Ave	Marian Street	Lydia Street	between 920 Heather Ave and 930 Heather Ave					10						
13	311	Virginia Street	Highlander Ave	Heather Ave			88									
14	320	Virginia Street	Highlander Ave	Heather Ave			112									
15	321	Virginia Street	Highlander Ave	Heather Ave			20	15								
16	331	Virginia Street	Highlander Ave	Heather Ave			96									

CITY OF LA HABRA

SIDEWALK AND CURB RAMP IMPROVEMENTS PROJECT

LIST OF QUANTITIES

Item No.	Address No.	Street Address	From	To	Location	R/R Concrete Walkway with Detectable Warning Surface	R/R Sidewalk	R/R Drive Approach (6 in)	R/R Private Walkway (4 in)	R/R Curb and Gutter (G = 24 in., CF = 8in.)	Private Parking Lot Striping	Remove Street Tree, 12 in. dia.	Remove Street Tree, 18 in. dia.	Remove Street Tree, 24 in. dia.	Plant Street Tree, 24 in. box tree	Install Root Barrier
17	400	Virginia Street	Highlander Ave	Heather Ave						36						
18	401	Virginia Street	Highlander Ave	Heather Ave				40								
19	410	Virginia Street	Highlander Ave	Heather Ave			200			22						
20	421	Virginia Street	Highlander Ave	Heather Ave				70								
21	430	Virginia Street	Highlander Ave	Heather Ave						12						
22	339	N Harbor	Francis Ave	Stearns Ave			20									
23	361	N Harbor	Francis Ave	Stearns Ave			234									
24	509	N Harbor	Whittier Blvd	Francis Ave			150									
25	609	N Harbor	Whittier Blvd	Francis Ave			40									
26	431	S Harbor	3rd Ave	Lambert Road			72									
27	511	S Harbor	3rd Ave	Lambert Road			9									
28	511	S Harbor	3rd Ave	East side of Harbor Blvd	Going south to Train Tracks		154									
29	1641	W El Portal Dr	Beach Blvd	El Rancho Dr			72									
30	1701	W El Portal Dr	Beach Blvd	El Rancho Dr			208									
31	1741	W El Portal Dr	Beach Blvd	El Rancho Dr			48									
32	1750	W El Portal Dr	Beach Blvd	El Rancho Dr			56									
33	204	S Walnut St	1st Ave	Portola Ave			48									
34	212	S Walnut St	1st Ave	Portola Ave			88									
35	220	S Walnut St	1st Ave	Portola Ave			120									
36	200	Knudson	1st Ave	3rd Ave			100									
37	201	Knudson	1st Ave	3rd Ave			60							1	1	1
38	231	Knudson	1st Ave	3rd Ave						30						
39	300	Knudson	1st Ave	3rd Ave			125									
40	321	Knudson	1st Ave	3rd Ave			90									
41	330	Knudson	1st Ave	3rd Ave			190			38						
42	340	Knudson	1st Ave	3rd Ave			100	100		44				1	1	1
43	501	El Camino	Sierra Vista Dr	Walnut Street			20									
44	530	El Camino	Sierra Vista Dr	Walnut Street			32									
45	531	El Camino	Sierra Vista Dr	Walnut Street			64									
46	541	El Camino	Sierra Vista Dr	Walnut Street			32									
47	610	El Camino	Sierra Vista Dr	Walnut Street			64									

CITY OF LA HABRA

SIDEWALK AND CURB RAMP IMPROVEMENTS PROJECT

LIST OF QUANTITIES

Item No.	Address No.	Street Address	From	To	Location	R/R Concrete Walkway with Detectable Warning Surface	R/R Sidewalk	R/R Drive Approach (6 in)	R/R Private Walkway (4 in)	R/R Curb and Gutter (G = 24 in., CF = 8in.)	Private Parking Lot Striping	Remove Street Tree, 12 in. dia.	Remove Street Tree, 18 in. dia.	Remove Street Tree, 24 in. dia.	Plant Street Tree, 24 in. box tree	Install Root Barrier
48	631	El Camino	Sierra Vista Dr	Walnut Street			20									
49	1230	Lynwood	Parkwood Ave	Patwood Dr			50									
50	1270	Lynwood	Parkwood Ave	Patwood Dr			65									
51	1320	Lynwood	Parkwood Ave	Patwood Dr			60			26						
52	1750	W Lambert Road				200	40									
					TOTAL:	200	6,849	721	20	233	2	2	7	2	11	11

EXHIBIT B
INSURANCE REQUIREMENTS

Contractor shall maintain and shall require all of its subcontractors, consultants, and other agents to maintain the insurance listed below. Any requirement for insurance to be maintained after completion of the work shall survive this agreement.

CITY reserves the right to review any and all of the required insurance policies and/or endorsements, but has no obligation to do so. Failure to demand evidence of full compliance with the insurance requirements set forth in this agreement or failure to identify any insurance deficiency shall not relieve Contractor from, nor be construed or deemed a waiver of, its obligation to maintain the required insurance at all times during the performance of this agreement.

A. Workers Compensation & Employers Liability Insurance

- Workers Compensation insurance with statutory limits as required by the Labor Code of the State of California.
- Employers Liability with limits of \$1,000,000 per Accident; \$1,000,000 Disease per employee; \$1,000,000 Disease per policy.
- The policy shall include a written waiver of the insurer's right to subrogate against CITY.
- Required Evidence Of Coverage:
 1. Subrogation waiver endorsement; and
 2. Properly completed Certificate of Insurance.

B. General Liability Insurance

- Commercial General Liability Insurance no less broad than Insurance Services Office (ISO) form CG 00 01.
- Coverage shall be on a standard occurrence form. Claims-Made forms are not acceptable without prior written consent. Modified, limited or restricted Occurrence forms are not acceptable without prior written consent.
- Minimum Limits: \$2,000,000 per Occurrence; \$4,000,000 General Aggregate; \$4,000,000 Products/Completed Operations Aggregate. The General Aggregate shall apply separately to each project. The required limits may be provided by a combination of General Liability Insurance and Commercial Excess or Umbrella Liability Insurance. If contractor maintains higher limits than the specified minimum limits, CITY requires and shall be entitled to coverage for the higher limits maintained by contractor.
- Any deductible or self-insured retention shall be shown on the Certificate of Insurance. If the deductible or self-insured retention exceeds \$25,000 it must be approved in advance by CITY. Contractor is responsible for any deductible or self-insured retention and shall fund it upon CITY'S written request, regardless of whether Contractor has a claim against the insurance or is named as a party in any action involving CITY.
- Coverage shall be continued for one (1) year after completion of the work.
- CITY shall be endorsed as an additional insured for liability arising out of ongoing and completed operations by or on behalf of the contractor. CITY shall continue to be an additional insured for completed operations for (1) year after completion of the work.
- The policy definition of "insured contract" shall include assumptions of liability

arising out of both ongoing operations and the products-completed operations hazard (“P” definition of insured contract in ISO form CG 00 01, or equivalent).

- The insurance provided to the additional insureds shall be primary to, and non-contributory with, any insurance or self-insurance program maintained by them.
- The policy shall cover inter-insured suits and include a “Separation of Insureds” or “severability” clause which treats each insured separately.
- The policy shall be endorsed to include a written waiver of the insurer’s right to subrogate against all persons or entities that are, or are required to be, additional insureds.
- The policy shall not contain a Contractors' Warranty or other similar language which eliminates or restricts insurance because of a subcontractor's failure to carry specific insurance or to supply evidence of such insurance.
- Required Evidence of Coverage:
 1. Copy of the additional insured endorsement or policy language granting additional insured status;
 2. Copy of the endorsement or policy language indicating that coverage applicable to the additional insureds is primary and non-contributory;
 3. Properly completed Certificate of Insurance; and
 4. Completed and signed Agent/Broker Questionnaire with supporting documentation as required.

C. Automobile Liability Insurance

- Minimum Limit: \$2,000,000 combined single limit per accident.
- Coverage shall apply to all owned, hired and non-owned vehicles.
- CITY shall qualify as an insured.
- Required Evidence of Coverage:
 1. Copy of the endorsement or policy language indicating that CITY is an insured; and
 2. Properly completed Certificate of Insurance.

D. Surety Bonds

- Bid bond.
- Performance and payment bonds for the entire contract price.
- The surety must be authorized to issue these bonds in the State of California.

E. Standards for Insurance Companies

- Insurers, other than the California State Compensation Insurance Fund, shall have an A.M. Best's rating of at least A:VII.

F. Documentation

- The Certificate of Insurance shall include the following reference: [Annual Sidewalk Improvements Project FY24-25 City Project No. 1-R-25]
- The name and address for Additional Insured endorsements and Certificates of Insurance is: City of La Habra
- Contractor shall provide immediate written notice if: (1) any of the required

City Project No. 1-R-25.

insurance policies is terminated; (2) the limits of any of the required policies are reduced; or (3) the deductible or self-insured retention is increased.

- Current Evidence of Coverage shall be provided for the entire required period of insurance.
- Upon written request, certified copies of required insurance policies shall be provided within thirty (30) days.

City Project No. 1-R-25.

EXHIBIT C

CERTIFICATES OF INSURANCE AND ENDORSEMENTS

EXHIBIT D
CLAIMS PROCEDURE

SUMMARY OF PUBLIC CONTRACT CODE § 9204

The following procedure will apply to any claims by the Contractor on the City:

A “claim” is a separate demand on the City by a contractor on a public works project and sent by registered mail or certified mail with return receipt requested, for one or more of the following:

- A time extension, including relief from penalties for delay
- Payment by the City of money damages under the terms of the contract
- Payment of an amount that is disputed by the City

Initial Review

The claim must be supported by appropriate documentation. The City has 45 days within which to review the claim and provide the contractor with a written statement identifying the disputed and undisputed portions of the claim. If the City does not issue a written statement, the claim is deemed rejected in its entirety. The City will pay any undisputed portion of the claim within 60 days of issuing the statement.

Meet & Confer

If the contractor disputes the City’s written response, or if the City does not issue one, the contractor may request in writing an informal conference to meet and confer for possible settlement of the claim. The City will schedule the meet and confer conference within 30 days of this request and provide a written statement identifying the remaining disputed and undisputed portions of the claim within 10 business days of the meet and confer. The City will pay the undisputed portion within 60 days of issuing this statement.

Mediation

With respect to any disputed portion remaining after the meet and confer, the City and contractor will submit the matter to nonbinding mediation, agree to a mediator within 10 business days after issuing the written statement, and share mediation costs equally. If mediation is unsuccessful, then the terms of the public works agreement and applicable law will govern resolution of the dispute.

Miscellaneous Provisions

Amounts not paid by the City in a timely manner bear interest at 7% per annum. Subcontractors may submit claims via this procedure through the general contractor. The City and contractor may waive the requirement to mediate, but cannot otherwise waive these claim procedures.