

**CITY OF LA HABRA
PUBLIC WORKS AGREEMENT FOR THE
Portola Park Lighting Project 2025**

THIS AGREEMENT (herein "Agreement") is made and entered into this 1st day of December, 2025 by and between the CITY OF LA HABRA, a municipal corporation, (herein "City") and Musco Sports Lighting, LLC (herein "Contractor"). The parties hereto agree as follows:

WITNESSETH:

A. WHEREAS, City requires the construction of lighting and electrical sources at Portola Park, 301 South Euclid Street, La Habra, CA 90631 as set forth more fully in this Agreement.

B. WHEREAS, Contractor represents to City that Contractor is qualified to perform said work and has submitted a proposal to City for the same.

C. WHEREAS, City desires to have Contractor perform said services on the terms and conditions set forth herein.

D. WHEREAS, no official or employee of City has a financial interest, within the provisions of Sections 1090-1092 of the California Government Code, in the subject matter of this Agreement.

NOW, THEREFORE, for and in consideration of the mutual covenants and conditions contained herein and for good and valuable consideration, the receipt and sufficiency of which is acknowledged by both parties, City and Contractor hereby agree as follows:

1.0 DEFINITIONS

1.1 Definitions. As used in this Agreement, the following definitions shall be applicable:

- (a) Contractor. Contractor shall mean Limited Liability Company, a California company located at 3002 Dow Avenue, #504, Tustin, CA 92780.
- (b) City. City shall mean the City of La Habra, a Municipal Corporation, located at 110 East La Habra Boulevard, La Habra, California 90631.
- (c) City Council. City Council shall mean the City Council of the City of La Habra.
- (d) Contract Officer. Contract Officer shall mean the person designated by the City Manager or City Engineer of City and shall have the duties set forth in Section 5.2.
- (e) Services. Services shall mean the services to be performed by the Contractor pursuant to this Agreement.

- (f) Satisfactory. Satisfactory shall mean satisfactory to the City Manager or his/her designee.

2.0 SERVICES OF CONTRACTOR

2.1 Scope of Services. In compliance with all terms and conditions of this Agreement, the Contractor shall provide those services specified in the "Scope of Services" attached hereto as Exhibit "A" and incorporated herein by this reference, which services may be referred to herein as the "services" or "work" hereunder. As a material inducement to the City entering into this Agreement, Contractor represents and warrants that Contractor is a provider of first class work and services and Contractor is experienced in performing the work and services contemplated herein and, in light of such status and experience, Contractor covenants that it shall follow the highest professional standards in performing the work and services required hereunder and that all materials will be of good quality, fit for the purpose intended.

2.2 Documents Included in Contract. This contract consists of this Agreement and any Exhibits, which are incorporated herein by this reference. In the event of an inconsistency, the terms of this Agreement shall govern.

2.3 Compliance with Law. All services rendered hereunder shall be provided in accordance with all ordinances, resolutions, statutes, rules, and regulations of the City and any Federal, State, or local governmental agency having jurisdiction in effect at the time service is rendered, including but not limited to, the claims procedure set forth in Public Contract Code Section 9204, a summary of which is attached to this agreement as Exhibit "E".

2.4 Licenses, Permits, Fees, and Assessments. Contractor shall obtain at its sole cost and expense such licenses, permits, and approvals as may be required by law for the performance of the services required by this Agreement, including registration with the Department of Industrial Relations of the State of California as required by Labor Code Section 1725.5 before commencing performance under this Agreement. Contractor shall have the sole obligation to pay for any fees, assessments, and taxes, plus applicable penalties and interest, which may be imposed by law and arise from or are necessary for the Contractor's performance of the services required by this Agreement, and shall indemnify, defend, and hold harmless City against any such fees, assessments, taxes penalties, or interest levied, assessed, or imposed against City hereunder. Contractor shall be responsible for all subcontractors' compliance with this Section 2.4.

2.5 Familiarity with Work. By executing this Contract, Contractor warrants that Contractor (a) has thoroughly investigated and considered the scope of services to be performed, (b) has carefully considered how the services should be performed, and (c) fully understands the facilities, difficulties, and restrictions attending performance of the services under this Agreement. If the services involve work upon any site, Contractor warrants that Contractor has or will investigate the site and is or will be fully acquainted with the conditions there existing, prior to commencement of services hereunder. Should Contractor discover any latent or unknown conditions, which will materially affect the performance of the services hereunder, Contractor shall immediately inform the City of such fact and shall not proceed except at Contractor's risk until written instructions are received from the Contract Officer.

2.6 Standard of Performance. Contractor, its subcontractors, and their employees, in the performance of Contractor's work under this Agreement, shall be responsible for exercising the

degree of skill and care required by customarily accepted good professional practices and procedures used in the Contractor's field.

Any costs for failure to meet the foregoing standard or to correct otherwise defective work that requires re-performance of the work, shall be borne in total by the Contractor and not by the City. The failure of a project to achieve the performance goals and objectives stated in this Agreement is not a basis for requesting re-performance unless the work conducted by Contractor and/or its subcontractors is deemed by the City to have failed the foregoing standard of performance.

In the event Contractor fails to perform in accordance with the above standard:

1. Contractor will re-perform, at its own expense, any task which was not performed to the reasonable satisfaction of City. Any work re-performed pursuant to this paragraph shall be completed within the time limitations originally set forth for the specific task involved. Contractor shall work any overtime required to meet the deadline for the task at no additional cost to the City;
2. The City shall provide a new schedule for the re-performance of any task pursuant to this paragraph in the event that re-performance of a task within the original time limitations is not feasible; and
3. The City shall have the option to direct Contractor not to re-perform any task which was not performed to the reasonable satisfaction of the City Project Manager pursuant to application of (1) and (2) above. In the event the City directs Contractor not to re-perform a task, the City shall negotiate a reasonable settlement for satisfactory work performed. No previous payment shall be considered a waiver of the City's right to reimbursement.

Nothing contained in this section is intended to limit any of the rights or remedies which the City may have under law.

2.7 Care of Work. The Contractor shall adopt reasonable methods during the life of the Agreement to furnish continuous protection to the work, and the equipment, materials, papers, documents, plans, studies, and/or other components thereof to prevent losses or damages, and shall be responsible for all such damages, to persons or property, until acceptance of the work by City, except such losses or damages as may be caused by City's own negligence.

2.8 Further Responsibilities of Parties. Both parties agree to use reasonable care and diligence to perform their respective obligations under this Agreement. Both parties agree to act in good faith to execute all instruments, prepare all documents and take all actions as may be reasonably necessary to carry out the purposes of this Agreement. Unless hereafter specified, neither party shall be responsible for the service of the other. Contractor shall require all subcontractors to comply with the provisions of this agreement.

2.9 Additional Services. City shall have the right at any time during the performance of the services, without invalidating this Agreement, to order extra work beyond that specified in the Scope of Services or make changes by altering, adding to, or deducting from said work. No such extra work may be undertaken unless a written change order is first given by the Contract Officer to the Contractor, incorporating therein any adjustment in (i) the Contract Sum as set forth in Section 3.1, and/or (ii) the time to perform this Agreement, which said adjustments are subject to the written approval of the Contractor. Any increase in compensation of ten percent (10%) or less of the Contract Sum, or in the time to perform of one hundred eighty (180) days or less, may be approved

by the Contract Officer. It is expressly understood by Contractor that the provisions of this Section shall not apply to services specifically set forth in the Scope of Services or reasonably contemplated therein. Contractor hereby acknowledges that it accepts the risk that the services to be provided pursuant to the Scope of Services may be more costly or time consuming than Contractor anticipates and that Contractor shall not be entitled to additional compensation therefore.

2.10 Prevailing Wage Laws. Contractor represents and warrants that it is registered with the Department of Industrial Relations as required by SB 854 and Labor Code 1725.5 and understands that this project is subject to compliance monitoring and enforcement by the Department of Industrial Relations. Contractor shall ensure that its subcontractors comply with said requirements. Contractor shall comply with Labor Code Section 1771.4 and shall post all legally required job site notices. In accordance with Labor Code Section 1770 et seq., the Director of the Department of Industrial Relations of the State of California has ascertained a general prevailing rate of wages, which is the minimum amount, which shall be paid to all workers employed to perform the work pursuant to this Agreement. A copy of the general prevailing wage rate determination is on file in the Office of the City Clerk and is hereby incorporated by reference into this Agreement. In accordance with the provisions of Labor Code Section 1810 et seq., eight (8) hours is the legal working day. Contractor must forfeit to the City Twenty Five Dollars (\$25.00) a day for each worker who works in excess of the minimum working hours when Contractor does not pay overtime. Contractor is required to post a copy of such wage rates at all times at the contract site. The statutory penalties for failure to pay prevailing wage or to comply with State wage and hour laws will be enforced. Contractor also shall comply with State law requirements to maintain payroll records and shall provide for certified records and inspection of records as required by California Labor Code Section 1770 et. seq., including Section 1776. Contractor shall comply with all statutory requirements relating to the employment of apprentices.

3.0 COMPENSATION

3.1 Contract Sum. For the services rendered pursuant to this Agreement, the Contractor shall be compensated as specified herein, but not exceeding the maximum contract amount of Six Hundred and Seventy Eight Thousand, Six Hundred and Two Dollars (\$ 678,602) (herein "Contract Sum"), except as provided in Section 2.9. The Contract Sum shall include the attendance of Contractor at all project meetings reasonably deemed necessary by the City; Contractor shall not be entitled to any additional compensation for attending said meetings.

3.2 Progress Payments. Prior to the first day of the month, during the progress of the work, commencing on the day and month specified in the Agreement, Contractor shall submit to the Contract Officer a complete itemized statement of all labor and materials incorporated into the work during the preceding month and the portion of the contract sum applicable thereto. Upon approval in writing by the Contract Officer, payment shall be made in thirty (30) days. City shall pay Contractor a sum based upon ninety-five percent (95%) of the contract price apportionment of the labor and materials incorporated into the work under the contract during the month covered by said statement. The remaining five percent (5%) thereof shall be retained as performance security. Refer to Section 8.4 of this Agreement for retention of funds.

4.0 PERFORMANCE SCHEDULE

4.1 Time of Essence. Time is of the essence in the performance of this Agreement.

4.2 Schedule of Performance. Contractor shall commence the services pursuant to this Agreement upon receipt of a written notice to proceed and shall perform all services within the time period(s) established in the "Schedule of Performance" attached hereto as Exhibit "B", and incorporated herein by this reference. When requested by the Contractor, extensions to the time period(s) specified in the Scope of Services may be approved in writing by the Contract Officer.

4.3 Force Majeure. The time period(s) specified in the Scope of Services for performance of the services rendered pursuant to this Agreement shall be extended because of any delays due to unforeseeable causes beyond the control and without the fault or negligence of the Contractor, including, but not restricted to, acts of God or of the public enemy, unusually severe weather, fires, earthquakes, floods, epidemics, quarantine restrictions, riots, strikes, freight embargoes, wars, litigation, and/or acts of any governmental agency, including the City, if the Contractor shall within ten (10) days of the commencement of such delay notify the Contract Officer in writing of the causes for the delay. The Contract Officer shall ascertain the facts and the extent of delay, and extend the time for performing the services for the period of the enforced delay when and if in the judgment of the Contract Officer such delay is justified. The Contract Officer's determination shall be final and conclusive upon the parties to this Agreement.

4.4 Term. Unless earlier terminated in accordance with Section 8.9 of this Agreement, this Agreement shall continue in full force and effect until final approval and acceptance of the project by the Contract Officer. Notwithstanding the foregoing, this Agreement shall terminate no later than September 30, 2026, unless the parties mutually agree in writing to extend the term.

5.0 COORDINATION OF WORK

5.1 Representative of Contractor. The following principals of Contractor are hereby designated as being the principals and representatives of Contractor authorized to act in its behalf with respect to the work specified herein and make all decisions in connection therewith:

Mike Marchetti
Musco Sports Lighting, LLC
3002 Dow Ave., #504
Tustin, CA 92780
949-754-0503 x6111
Mike.marchetti@musco.com

It is expressly understood that the experience, knowledge, capability and reputation of the foregoing principals were a substantial inducement for City to enter into this Agreement. Therefore, the foregoing principals shall be responsible during the term of this Agreement for directing all activities of Contractor and devoting sufficient time to personally supervise the services hereunder. For purposes of this Agreement, the foregoing principals may not be replaced nor may their responsibilities be substantially reduced by Contractor without the express written approval of City.

5.2 Contract Officer. The Contract Officer shall be such person as may be designated by the City Manager or City Engineer of City. It shall be the Contractor's responsibility to assure that the Contract Officer is kept informed of the progress of the performance of the services and the Contractor shall refer any decisions that must be made by City to the Contract Officer. Unless otherwise specified herein, any approval of City required hereunder shall mean the approval of the Contract Officer. The Contract Officer shall have authority to sign all documents on behalf of the City required hereunder to carry out the terms of this Agreement.

5.3 Prohibition Against Assignment. The experience, knowledge, capability, and reputation of Contractor, its principals and employees were a substantial inducement for the City to enter into this Agreement. Neither this Agreement nor any interest herein may be transferred, assigned, conveyed, hypothecated, or encumbered voluntarily or by operation of law, whether for the benefit of creditors or otherwise, without the prior written approval of City. Transfers restricted hereunder shall include the transfer to any person or group of persons acting in concert of more than twenty five percent (25%) of the present ownership and/or control of Contractor, taking all transfers into account on a cumulative basis. In the event of any such unapproved transfer, including any bankruptcy proceeding, this Agreement shall be void. No approved transfer shall release the Contractor or any surety of Contractor of any liability hereunder without the express consent of City.

5.4 Independent Contractor. Neither the City nor any of its employees shall have any control over the manner, mode, or means by which Contractor, its subcontractors, agents, or employees, performs the services required herein, except as otherwise set forth herein. City shall have no voice in the selection, discharge, supervision, or control of Contractor's employees, subcontractors, servants, representatives, or agents, or in fixing their number, compensation, or hours of service. Contractor shall perform all services required herein as an independent contractor of City and shall remain at all times as to City a wholly independent contractor with only such obligations as are consistent with that role. Contractor shall not at any time or in any manner represent that it or any of its subcontractors, agents, or employees are agents or employees of City. City shall not in any way or for any purpose become or be deemed to be a partner of Contractor in its business or otherwise or a joint venture or a member of any joint enterprise with Contractor.

5.5 Identity of Persons Performing Work. Contractor represents that it employs or will employ at its own expense all personnel required for the satisfactory performance of any and all tasks and services set forth herein. Contractor represents that the tasks and services required herein will be performed by Contractor or under its direct supervision, and that all personnel engaged in such work shall be fully qualified and shall be authorized and permitted under applicable State and local law to perform such tasks and services.

5.6 Utility Relocation. City is responsible for removal, relocation, or protection of existing main or trunkline utilities to the extent such utilities were not identified in the invitation for bids or specifications. City shall reimburse contractor for any costs incurred in locating, repairing damage not caused by contractor, and removing or relocating such unidentified utility facilities, including equipment idled during such work. Contractor shall not be assessed liquidated damages for delay arising from the removal or relocation of such unidentified utility facilities.

5.7 Trenches or Excavations. Pursuant to California Public Contract Code Section 7104, in the event the work included in this Agreement requires excavations more than four (4) feet in depth, the following shall apply.

- (a) Contractor shall promptly, and before the following conditions are disturbed, notify City, in writing, of any: (1) material that Contractor believes may be material that is hazardous waste, as defined in Section 25117 of the Health and Safety Code, that is required to be removed to a Class I, Class II, or Class III disposal site in accordance with provisions of existing law; (2) Subsurface or latent physical conditions at the site different from those indicated; or (3) Unknown physical conditions at the site of any unusual nature, different materially from those ordinarily encountered and

generally recognized as inherent in work of the character provided for in the contract.

- (b) City shall promptly investigate the conditions, and if it finds that the conditions do materially so differ, or do involve hazardous waste, and cause a decrease or increase in Contractor's cost of, or the time required for, performance of any part of the work shall issue a change order per Section 2.9 of this Agreement.
- (c) That, in the event that a dispute arises between City and Contractor whether the conditions materially differ, or involve hazardous waste, or cause a decrease or increase in Contractor's cost of, or time required for, performance of any part of the work, Contractor shall not be excused from any scheduled completion date provided for by the contract, but shall proceed with all work to be performed under the contract. Contractor shall retain any and all rights provided either by contract or by law, which pertain to the resolution of disputes and protests between the contracting parties.

6.0 INSURANCE, INDEMNIFICATION, AND BONDS

6.1 Insurance. The Contractor and all subcontractors, if any, shall procure and maintain, at its sole cost and expense, in a form and content satisfactory to City, during the entire term of this Agreement, including any extension thereof, insurance as set forth in Exhibit "C" attached hereto and incorporated herein by this reference.

Conditions:

In accordance with Public Contract Code Section 20170, the insurance of surety companies who provide or issue the policy shall have been admitted to do business in the State of California with a credit rating of A- or better.

The City of La Habra, its officers, officials, employees, agents, and volunteers shall be named as additional insureds.

Prior to commencement of any work under this contract, Contractor shall deliver to the City insurance endorsements confirming the existence of the insurance required by this contract, and including the applicable clauses as set forth in Exhibit "C" attached hereto and incorporated herein by this reference.

Such endorsements shall be signed by an authorized representative of the insurance company and shall include the signatory's company affiliation and title. Should it be deemed necessary by the City, it shall be Contractor's responsibility to see that the City receives documentation, acceptable to the City, which sustains that the individual signing said endorsements is indeed authorized to do so by the insurance company.

If the Contractor fails to maintain the aforementioned insurance, or secure and maintain the aforementioned endorsement, the City may obtain such insurance, and deduct and retain the amount of the premiums for such insurance from any sums due under the agreement. However, procuring of said insurance by the City is an alternative to other remedies the City may have, and is not the exclusive remedy for failure of Contractor to maintain said insurance or secure said endorsement. In addition to any other remedies

the City may have upon Contractor's failure to provide and maintain any insurance or policy endorsements to the extent and within the time herein required, the City shall have the right to order Contractor to stop work hereunder, and/or withhold any payment(s) which became due to Contractor hereunder until Contractor demonstrates compliance with the requirements hereof.

Nothing herein contained shall be construed as limiting in any way the extent to which Contractor may be held responsible for payments of damages to persons or property resulting from Contractor's or its subcontractor's performance of the work covered under this agreement.

Each contract between the Contractor and any subcontractor shall require the subcontractor to maintain the same policies of insurance that the Contractor is required to maintain pursuant to this Section 6.1.

6.2 Certificates of Insurance. Contractor shall provide to City certificates of insurance showing the insurance coverages, as well as providing the City with the required endorsements, in a form and content approved by City, prior to performing any services under this Agreement. The certificates of insurance and endorsements shall be attached to this Agreement as Exhibit "D" and are incorporated herein by this reference.

6.3 Indemnification. Contractor shall protect, defend, indemnify, and hold free and harmless the City of La Habra, its officers, officials, employees, agents, and volunteers, at Contractor's sole expense, from and against any and all actions, suits, claims, damages to persons or property, losses, costs, penalties, obligations, errors, omissions, or liabilities (herein "claims or liabilities") that may be asserted or claimed by any person, firm, or entity arising or alleged to arise out of or in any way connected with the performance of the work, operations, or activities of Contractor, its agents, employees, subcontractors, or invitees, provided for herein, or arising or alleged to arise from the acts or omissions of Contractor hereunder, or arising or alleged to arise from Contractor's performance of or failure to perform any term, provision, covenant or condition of this Agreement including all acts or omissions, willful misconduct or negligent conduct, whether active or passive, on the part of the Contractor, its employees, and/or subcontractors.

- (a) Contractor will defend any action or actions filed in connection with any of said claims or liabilities and will pay all costs and expenses, including legal costs and attorneys' fees incurred in connection therewith.
- (b) Contractor will promptly pay any judgment rendered against the City, its officers, officials, employees, agents, or volunteers for any such claims or liabilities arising or alleged to arise out of or in connection with Contractor's (or its agents', employees', subcontractors', or invitees') negligent performance of or failure to perform such work, operations, or activities hereunder; and Contractor agrees to save and hold the City, its officers, officials, employees, agents, and volunteers harmless therefrom.
- (c) In the event the City, its officers, officials, employees, agents, or volunteers are made a party to any action or proceeding filed or prosecuted against Contractor for such damages or other claims arising or alleged to arise out of or in connection with the performance of or failure to perform the work, operation or activities of Contractor hereunder, Contractor shall pay to the

City, its officers, officials, employees, agents, or volunteers any and all costs and expenses incurred by the City, its officers, officials, employees, agents, or volunteers in such action or proceeding, including but not limited to, legal costs and attorneys' fees for counsel selected by City.

- (d) Contractor's duty to defend and indemnify as set out in this Section 6.3 shall include any claims, liabilities, obligations, losses, demands, actions, penalties, suits, costs, expenses or damages or injury to persons or property arising or alleged to arise from, in connection with, as a consequence of or pursuant to any State or Federal law or regulation regarding hazardous substances, including but not limited to the Federal Insecticide, Fungicide and Rodenticide Act ("FIFRA"), Comprehensive Environmental Response, Compensation and Liability Act of 1980 ("CERCLA"), Resource Conservation and Recovery Act of 1976 ("RCRA"), the Hazardous and Solid Waste Amendments of 1984, the Hazardous Material Transportation Act, the Toxic Substances control Act, the Clean Air Act, the Clean Water Act, the California Hazardous Substance Account Act, the California Hazardous Waste Control Law or the Porter-Cologne Water Quality Control Act, as any of those statutes may be amended from time to time.

Notwithstanding the foregoing, Contractor shall not be liable for the defense or indemnification of the City for claims, actions, complaints, or suits arising out of the sole active negligence or willful misconduct of the City.

The Contractor's indemnification obligations pursuant to this Section 6.3 shall survive the termination of this Agreement. Contractor shall require the same indemnification from all subcontractors.

6.4 PERS Eligibility Indemnification. In the event that Consultant or any employee, agent, or subcontractor of Consultant providing services under this Agreement claims or is determined by a court of competent jurisdiction or the California Public Employees Retirement System (PERS) to be eligible for enrollment in PERS as an employee of the City, Consultant shall indemnify, defend, and hold harmless City for the payment of any employee and/or employer contributions for PERS benefits on behalf of Consultant or its employees, agents, or subcontractors, as well as for the payment of any penalties and interest on such contributions, which would otherwise be the responsibility of City.

Notwithstanding any other agency, State, or Federal policy, rule, regulation, law, or ordinance to the contrary, Consultant and any of its employees, agents, and subcontractors providing service under this Agreement shall not qualify for or become entitled to, and hereby agree to waive any claims to, any compensation, benefit, or any incident of employment by City, including but not limited to eligibility to enroll in PERS as an employee of City and entitlement to any contribution to be paid by City for employer contribution and/or employee contributions for PERS benefits.

6.5 Labor and Materials and Performance Bonds. Concurrently with execution of this Agreement, Contractor shall deliver to City a labor and materials bond and a performance bond each in the sum of the amount of this Agreement, in the forms provided by the City Clerk, which secures the faithful performance of this Agreement. The bonds shall contain the original notarized signature of an authorized officer of the surety and affixed thereto shall be a certified and current copy of his

power of attorney. The bonds shall be unconditional and remain in force during the entire term of the Agreement and shall be null and void only if the Contractor promptly and faithfully performs all terms and conditions of this Agreement.

6.6 Sufficiency of Insurer or Surety. Insurance required by this Agreement shall be satisfactory only if issued by companies qualified to do business in California, rated "A-" or better in the most recent edition of Best's Key Rating Guide or in the Federal Register, and only if they are of a Financial Size Category Class VII or larger, unless such requirements are waived by the Risk Manager of the City due to unique circumstances. In the event the Project Manager and Risk Manager determine that the work or services to be performed under this Agreement creates an increased risk of loss to the City, the Contractor agrees that the minimum limits of the insurance policies required by this Section 6 may be changed accordingly upon receipt of written notice from the Project Manager provided that the Contractor shall have the right to appeal a determination of increased coverage by the Project Manager to the City Council of City within ten (10) days of receipt of notice from the Project Manager.

6.7 Substitution of Securities. Pursuant to California Public Contract Code Section 22300, substitution of eligible equivalent securities for any monies withheld to ensure performance under the contract for the work to be performed will be permitted at the request and expense of the successful bidder.

7.0 RECORDS AND REPORTS

7.1 Reports. Contractor shall periodically prepare and submit to the Contract Officer such reports concerning the performance of the services required by this Agreement as the Contract Officer shall require. Contractor hereby acknowledges that the City is greatly concerned about the cost of work and services to be performed pursuant to this Agreement. For this reason, Contractor agrees that if Contractor becomes aware of any facts, circumstances, techniques, or events that may or will materially increase or decrease the cost of the work or services contemplated herein or, if Contractor is providing design services, the cost of the project being designed, Contractor shall promptly notify the Contract Officer of said fact, circumstance, technique or event and the estimated increased or decreased cost related thereto and, if Contractor is providing design services, the estimated increased or decreased cost estimate for the project being designed.

7.2 Records. Contractor shall keep, and require subcontractors to keep, such books and records (including but not limited to payroll records as required herein) as shall be necessary to perform the services required by this Agreement and enable the Contract Officer to evaluate the performance of such services. The Contract Officer shall have full and free access to such books and records at all times during normal business hours of City, including the right to inspect, copy, audit and make records and transcripts from such records. Such records shall be maintained for a period of three (3) years following completion of the services hereunder, and the City shall have access to such records in the event any audit is required.

7.3 Ownership of Documents. All drawings, specifications, reports, records, documents, and other materials prepared by Contractor, its employees, subcontractors, and agents in the performance of this Agreement shall be the property of City and shall be delivered to City upon request of the Contract Officer or upon the termination of this Agreement, and Contractor shall have no claim for further employment or additional compensation as a result of the exercise by City of its full rights of ownership of the documents and materials hereunder. Contractor may retain copies of

such documents for its own use. Contractor shall have an unrestricted right to use the concepts embodied therein. All subcontractors shall provide for assignment to City of any documents or materials prepared by them, and in the event Contractor fails to secure such assignment, Contractor shall indemnify City for all damages resulting therefrom.

7.4 Public Records Act Disclosure. Contractor has been advised and is aware that this Agreement and all reports, documents, information, and data, including, but not limited to, computer tapes, discs or files furnished or prepared by Contractor, or any of its subcontractors, pursuant to this Agreement and provided to City may be subject to public disclosure as required by the California Public Records Act (California Government Code Section 7920.000 *et seq.*). Exceptions to public disclosure may be those documents or information that qualify as trade secrets, as that term is defined in the California Government Code Section 7924.510, and of which Contractor informs City of such trade secret. The City will endeavor to maintain as confidential all information obtained by it that is designated as a trade secret. The City shall not, in any way, be liable or responsible for the disclosure of any trade secret including, without limitation, those records so marked if disclosure is deemed to be required by law or by order of the Court.

8.0 GENERAL PROVISIONS

8.1 Governing Law. This Agreement shall be construed and interpreted both as to validity and to performance of the parties in accordance with the laws of the State of California. Legal actions concerning any dispute, claim, or matter arising out of or in relation to this Agreement shall be instituted in the Superior Court of the County of Orange, State of California, or any other appropriate court in such county, and Contractor covenants and agrees to submit to the personal jurisdiction of such court in the event of such action.

8.2 Representatives. The City Manager or his or her designee shall be the representative of City for purposes of this Agreement and may issue all consents, approvals, directives, and agreements on behalf of the City, called for by this Agreement, except as otherwise expressly provided in this Agreement.

The Principal set forth in Section 5.1 above shall be the representative for Contractor for purposes of this Agreement, and shall be authorized to issue all consents, approvals, directives, and agreements on behalf of Contractor called for by this Agreement, except as otherwise expressly provided in this Agreement.

8.3 Disputes. In the event either party fails to perform its obligations hereunder, the nondefaulting party shall provide the defaulting party written notice of such default. The defaulting party shall have ten (10) days to cure the default; provided that, if the default is not reasonably susceptible to being cured within said ten (10) day period, the defaulting party shall have a reasonable time to cure the default, not to exceed a maximum of thirty (30) days, so long as the defaulting party commences to cure such default within ten (10) days of service of such notice and diligently prosecutes the cure to completion; provided further that if the default is an immediate danger to the health, safety and general welfare, the defaulting party shall take such immediate action as may be necessary. Notwithstanding the foregoing, the nondefaulting party may, in its sole and absolute discretion, grant a longer cure period. Should the defaulting party fail to cure the default within the time period provided in this Section, the nondefaulting party shall have the right, in addition to any other rights the nondefaulting party may have at law or in equity, to terminate this Agreement. Compliance with the provisions of this Section 8.3 shall be a condition precedent to bringing any

legal action, and such compliance shall not be a waiver of any party's right to take legal action in the event that the dispute is not cured.

8.4 Retention of Funds. Progress payments shall be made in accordance with the provisions of Section 3.2 of this Agreement. In accordance with said section, City shall pay Contractor a sum based upon ninety-five percent (95%) of the contract price apportionment of the labor and materials incorporated into the work under the contract during the month covered by said statement. The remaining five percent (5%) thereof shall be retained as performance security to be paid to the Contractor within sixty (60) days after final acceptance of the work by the City Council, after Contractor shall have furnished City with a release of all undisputed contract amounts if required by City. In the event there are any claims specifically excluded by Contractor from the operation of the release, the City may retain proceeds (per Public Contract Code 7107) of up to 150% of the amount in dispute. City's failure to deduct or withhold shall not affect Contractor's obligations hereunder.

8.5 Waiver. No delay or omission in the exercise of any right or remedy by a nondefaulting party on any default shall impair such right or remedy or be construed as a waiver. A party's consent to or approval of any act by the other party requiring the party's consent or approval shall not be deemed to waive or render unnecessary the other party's consent to or approval of any subsequent act. Any waiver by either party of any default must be in writing and shall not be a waiver of any other default concerning the same or any other provision of this Agreement.

8.6 Rights and Remedies. Rights and Remedies are cumulative except with respect to rights and remedies expressly declared to be exclusive in this Agreement, the rights and remedies of the parties are cumulative and the exercise by either party of one or more of such rights or remedies shall not preclude the exercise by it, at the same or different times, of any other rights or remedies for the same default or any other default by the other party.

8.7 Legal Action. In addition to any other rights or remedies, either party may take legal action, in law or in equity, to cure, correct or remedy any default, to recover damages for any default, to compel specific performance of this Agreement, to obtain declaratory or injunctive relief, or to obtain any other remedy consistent with the purposes of this Agreement.

8.8 Liquidated Damages. Since the determination of actual damages for any delay in performance of this Agreement would be extremely difficult or impractical to determine in the event of a breach of this Agreement, the Contractor and its sureties shall be liable for and shall pay to the City Five Hundred Dollars (\$500.00) as liquidated damages for each working day of delay in the performance of any service required hereunder, as specified in the Scope of Services (Exhibit "A") or Schedule of Performance (Exhibit "B"). The City may withhold from any monies payable on account of services performed by the Contractor any accrued liquidated damages.

8.9 Termination for Default of Contractor. If termination is due to the failure of the Contractor to fulfill its obligations under this Agreement, Contractor shall vacate any City owned property which Contractor is permitted to occupy hereunder and City may, after compliance with the provisions of Section 8.3, take over the work and prosecute the same to completion by contract or otherwise, and the Contractor shall be liable to the extent that the total cost for completion of the services required hereunder exceeds the compensation herein stipulated (provided that the City shall use reasonable efforts to mitigate such damages), and City may withhold any payments to the Contractor for the purpose of setoff or partial payment of the amounts owed the City as previously stated.

8.10 Notice. Any notice, demand, request, document, consent, approval, or communication either party desires or is required to give to the other party or any other person shall be in writing and shall be deemed to be given when served personally or deposited in the U.S. Mail, prepaid, first-class mail, return receipt requested, addressed as follows:

To City: City of La Habra
110 East La Habra Boulevard
La Habra, California 90631
Attn.: Kimberly Albarian, Deputy Director of Community Services

To Contractor: Musco Lighting, LLC
3002 Dow Avenue, #504
Tustin, CA 92780

8.11 Non-liability of City Officers and Employees. No officer or employee of the City shall be personally liable to the Contractor, or any successor in interest, in the event of any default or breach by the City or for any amount which may become due to the Contractor or to its successor, or for breach of any obligation of the terms of this Agreement.

8.12 Conflict of Interest. The Contractor warrants that it has not paid or given and will not pay or give any third party any money or other consideration for obtaining this Agreement.

Contractor and its officers, employees, associates, and subcontractors, if any, will comply with all conflict of interest statutes of the State of California applicable to Contractor's services under this agreement, including, but not limited to, the Political Reform Act (Government Code Sections 81000, *et seq.*) and Government Code Section 1090. During the term of this Agreement, Contractor and its officers, employees, associates, and subcontractor shall not, without the prior written approval of the City Representative, perform work for another person or entity for whom Contractor is not currently performing work that would require Contractor or one of its officers, employees, associates, or subcontractors to abstain from a decision under this Agreement pursuant to a conflict of interest statute. Contractor's duties and services under this Agreement shall not include preparing or assisting the City with any portion of the City's preparation of a request for proposals, request for qualifications, or any other solicitation regarding a subsequent or additional contract with the City. The City shall at all times retain responsibility for public contracting, including with respect to any subsequent phase of this project. Contractor's participation in the planning, discussions, or drawing of project plans or specifications shall be limited to conceptual, preliminary, or initial plans or specifications. Contractor shall cooperate with the public entity to ensure that all bidders for a subsequent contract on any subsequent phase of this project, if any, have access to the same information, including all conceptual, preliminary, or initial plans or specifications prepared by Contractor pursuant to this Agreement.

8.13 Covenant Against Discrimination. Contractor covenants that, by and for itself, its heirs, executors, assigns, and all persons claiming under or through them, that there shall be no discrimination against or segregation of, any person or group of persons on account of race, color, creed, religion, sex, marital status, national origin, or ancestry in the performance of this Agreement. To the extent required by law, contractor shall take affirmative action to insure that applicants are employed and that employees are treated during employment without regard to their race, color, creed, religion, sex, marital status, national origin, or ancestry.

8.14 Interpretation. The terms of this Agreement shall be construed in accordance with the meaning of the language used and shall not be construed for or against either party by reason of the authorship of this Agreement or any other rule of construction which might otherwise apply.

8.15 Severability. In the event that any one or more of the phrases, sentences, clauses, paragraphs, or sections contained in this Agreement shall be declared invalid or unenforceable by a valid judgment or decree of a court of competent jurisdiction, such invalidity or unenforceability shall not affect any of the remaining phrases, sentences, clauses, paragraphs, or sections of this Agreement which are hereby declared as severable and shall be interpreted to carry out the intent of the parties hereunder unless the invalid provision is so material that its invalidity deprives either party of the basic benefit of their bargain or renders this Agreement meaningless.

8.16 Hiring of Undocumented Workers Prohibited. Contractor shall not hire or employ any person to perform work within the City of La Habra or allow any person to perform work required under this Agreement unless such person is properly documented and legally entitled to be employed within the United States. Further, Contractor shall comply with the following:

- (a) Unauthorized Aliens. Contractor hereby represents and warrants that it will comply with all of the provisions of the Federal Immigration and Nationality Act, 8 U.S.C.A. §§ 1101, et seq., as amended, and in connection therewith, shall not employ unauthorized aliens as defined therein. Should Contractor so employ such unauthorized aliens for the performance of any work and/or services under this Agreement, and should any liability or sanctions be imposed against City for such use of unauthorized aliens, Contractor hereby agrees to reimburse City for any and all liabilities, actions, suits, claims, demands, losses, costs, judgments, arbitration awards, settlements, damages, demands, orders, or penalties which arise out of or are related to such employment, together with any and all costs, including attorneys' fees, incurred by City.
- (b) E-Verify. If Contractor is not already enrolled in the U.S. Department of Homeland Security's E-Verify program, Contractor shall enroll in the E-Verify program within fifteen (15) days of the effective date of this Agreement to verify the employment authorization of employees assigned to perform work hereunder. Contractor shall verify employment authorization within three (3) days of hiring a new employee to perform work under this Agreement. Information pertaining to the E-Verify program can be found at <http://www.uscis.gov>, or access the registration page at <https://e-verify.uscis.gov/enroll>. Contractor shall certify its registration with E-Verify and provide City its registration number within sixteen days of the effective date of this Agreement. Failure to provide certification will result in withholding payment until full compliance is demonstrated.¹

8.17 Unfair Business Practices Claims. In entering into a public works contract or a subcontract to supply goods, services, or materials pursuant to a public works contract, the contractor or subcontractor offers and agrees to assign to the awarding body all rights, title, and interest in and to all causes of action it may have under Section 4 of the Clayton Act (15 U.S.C. Sec. 15) or under the Cartwright Act (Chapter 2, (commencing with Section 16700) of Part 2 of Division 7 of the Business and Professions Code), arising from purchases of goods, services, or materials pursuant to the public works contract or the subcontract. This assignment shall be

made and become effective at the time the awarding body renders final payment to the contractor without further acknowledgment by the parties. (Sec. 7103.5, California Public Contract Code).

8.18 Corporate Authority. The persons executing this Agreement on behalf of the parties hereto warrant that (i) such party is duly organized and existing, (ii) they are duly authorized to execute and deliver this Agreement on behalf of said party, (iii) by so executing this Agreement, such party is formally bound to the provisions of this Agreement, and (iv) the entering into this Agreement does not violate any provision of any other Agreement to which said party is bound.

8.19 PERS Eligibility Indemnification. In the event that Contractor or any employee, agent, or subcontractor of Contractor providing services under this Agreement claims or is determined by a court of competent jurisdiction or the California Public Employees Retirement System (PERS) to be eligible for enrollment in PERS as an employee of the City, Contractor shall indemnify, defend, and hold harmless City for the payment of any employee and/or employer contributions for PERS benefits on behalf of Contractor or its employees, agents, or subcontractors, as well as for the payment of any penalties and interest on such contributions, which would otherwise be the responsibility of City.

Notwithstanding any other agency, State, or Federal policy, rule, regulation, law, or ordinance to the contrary, Contractor and any of its employees, agents, and subcontractors providing service under this Agreement shall not qualify for or become entitled to, and hereby agree to waive any claims to, any compensation, benefit, or any incident of employment by City, including but not limited to eligibility to enroll in PERS as an employee of City and entitlement to any contribution to be paid by City for employer contribution and/or employee contributions for PERS benefits.

8.20 Cooperation. In the event any claim or action is brought against City relating to Contractor's performance or services rendered under this Agreement, Contractor shall render any reasonable assistance and cooperation which City might require.

8.21 Legal Responsibilities. The Contractor shall keep itself informed of City, State, and Federal laws, ordinances, and regulations, which may in any manner affect the performance of its services pursuant to this Agreement. The Contractor shall at all times observe and comply with all such laws, ordinances, and regulations. Neither the City, nor its officers, agents, or employees shall be liable at law or in equity as a result of the Contractor's failure to comply with this section.

8.22 Termination for Convenience. The City may terminate this Agreement without cause for convenience of the City upon giving contractor 30 days prior written notice of termination of the Agreement. Upon receipt of the notice of termination the Contractor shall cease all further work pursuant to the Agreement. Upon such termination by the City the Contractor shall not be entitled to any other remedies, claims, actions, profits, or damages except as provided in this paragraph. Upon the receipt of such notice of termination Contractor shall be entitled to the following compensation:

1. The contract value of the work completed to and including the date of receipt of the notice of termination, less the amount of progress payments received by contractor.
2. Actual move-off costs including labor, rental fees, equipment transportation costs, the costs of maintaining on-site construction office for supervising the mover-off.

3. The cost of materials custom made for this Agreement which cannot be used by the Contractor in the normal course of his business, and which have not been paid for by City in progress payments.
4. All costs shall not include any markups as might otherwise be allowed by any plans or specifications which were a part of the Agreement.

The provisions of this paragraph shall supersede any other provision of the Agreement or any provision of any plans, specification, addendums, or other documents which are or may become a part of this Agreement. City and Contractor agree that the provisions of this paragraph are a substantive part of the consideration for this Agreement.

8.23 Responsibility for Errors. Contractor shall be responsible for its work and results under this Agreement. Contractor, when requested, shall furnish clarification and/or explanation as may be required by the City's representative, regarding any services rendered under this Agreement at no additional cost to City. In the event that an error or omission attributable to Contractor occurs, then Contractor shall, at no cost to City, provide all necessary design drawings, estimates, and other Contractor professional services necessary to rectify and correct the matter to the sole satisfaction of City and to participate in any meeting required with regard to the correction.

8.24 Order of Precedence. In the event of an inconsistency in this Agreement and any of the attached Exhibits, the terms set forth in this Agreement shall prevail. If, and to the extent this Agreement incorporates by reference any provision of any document, such provision shall be deemed a part of this Agreement. Nevertheless, if there is any conflict among the terms and conditions of this Agreement and those of any such provision or provisions so incorporated by reference, this Agreement shall govern over the document referenced.

8.25 Costs. Each party shall bear its own costs and fees incurred in the preparation and negotiation of this Agreement and in the performance of its obligations hereunder except as expressly provided herein.

8.26 No Third Party Beneficiary Rights. This Agreement is entered into for the sole benefit of City and Contractor and no other parties are intended to be direct or incidental beneficiaries of this Agreement and no third party shall have any right in, under or to this Agreement.

8.27 Headings. Paragraphs and subparagraph headings contained in this Agreement are included solely for convenience and are not intended to modify, explain or to be a full or accurate description of the content thereof and shall not in any way affect the meaning or interpretation of this Agreement.

8.28 Construction. The parties have participated jointly in the negotiation and drafting of this Agreement. In the event an ambiguity or question of intent or interpretation arises with respect to this Agreement, this Agreement shall be construed as if drafted jointly by the parties and in accordance with its fair meaning. There shall be no presumption or burden of proof favoring or disfavoring any party by virtue of the authorship of any of the provisions of this Agreement.

8.29 Counterparts. This Agreement may be executed in one or more counterparts, each of which shall be deemed an original. All counterparts shall be construed together and shall

constitute one agreement.

8.30 Funding Source Conditions – Contractor’s Obligation. Contractor acknowledges that the City may be paying for the Project by using funds it receives or will receive from various funding sources in the form of grants and/or subsidies, and the like under certain terms and conditions. Contractor warrants that it is not suspended or debarred from doing business with the United States government and can legally be paid from federal funds. Contractor acknowledges and agrees that any failure of the Contractor and/or its subcontractors to perform its obligations under the Contract, including, but not limited to, timely submitting accurate reports and records, that in any way results in the City not meeting the terms and conditions placed on the funds by the funding source, or forfeiting its entitlement to or, otherwise, not receiving, the funds, then the Contractor shall be liable to pay the City for the funds not granted to the City on the Project.

8.31 Entire Agreement. This Agreement constitutes the entire agreement between the parties with respect to any matter referenced herein and supersedes any and all other prior writings and oral negotiations. This Agreement may be modified only in writing, and signed by the parties in interest at the time of such modification. The terms of this Agreement shall prevail over any inconsistent provision in any other contract document appurtenant hereto, including exhibits to this Agreement.

IN WITNESS WHEREOF, the parties have executed and entered into this Agreement as of the date first written above.

ATTEST:

CITY OF LA HABRA,
A municipal corporation

Jim Sadro, City Manager

Date: _____

ATTEST:

Rhonda J. Barone, CMC, City Clerk

CONTRACTOR:

Signature

Date: _____

Name and Title

Social Security or Taxpayer ID Number

APPROVED AS TO FORM:

Keith F. Collins, City Attorney

Date: _____

APPROVED AS TO CONTENT:

Kimberly Albarian, Deputy Director of Community Services
Project Manager

Date: _____

DEPARTMENTAL APPROVAL:

Kelly Fujio, Director of Community Services

Date: _____

**LABOR AND MATERIAL PAYMENT BOND
PUBLIC WORK (CALIFORNIA)**

KNOW ALL PERSONS BY THESE PRESENTS:

WHEREAS, _____, as Principal, has entered into a contract dated _____, with the City of La Habra (Obligee) referred to and made a part hereof to perform the following work, to wit: _____ and all appurtenant work in accordance with PROJECT NO. _____, which requires Principal to file this bond to secure claims made in relation to the project.

NOW THEREFORE, we, _____, as Principal, and _____, a corporation organized under the laws of _____ and duly authorized to transact business in the State of California, as Surety, are held firmly bound unto the City of La Habra, as Obligee, and all sub-contractors, laborers, material persons and other persons employed in the performance of the referenced agreement, in the sum of _____ Dollars (\$...), lawful money of the United States of America, for the payment whereof well and truly to be made the Principal and Surety bind themselves, their heirs, executors, administrators, successors, and assigns, jointly and severally, firmly by these presents.

If the above bounden PRINCIPAL, his or its heirs, executors, administrators, successors, assigns, or any of his or its sub-contractors, fails to pay for any materials, provisions, provender, or other supplies, or teams, implements or machinery, used in, upon, for or about the performance of the work contracted to be done, or for any work or labor to persons named in Section 9100 or the Civil Code, thereon of any kind, or for amounts due under the Unemployment Insurance Code with respect to such work or labor deducted, withheld and paid over to the Employment Development Department from the wages of employees of the contractor and sub-contractors pursuant to Section 13020 of the Unemployment Insurance Code, that the SURETY on this bond will pay the same, in an amount not exceeding the sum specified in this bond, AND ALSO, in case suit is brought upon this bond, a reasonable attorney's fee, which shall be awarded by the court to the prevailing party in said suit, said attorney's fee to be taxed as costs in said suit and to be included in the judgment herein rendered.

As part of the obligation secured hereby, the SURETY shall not be exonerated or released from the obligation of the bond by any change, alteration, or modification in or of any contract, plans, specifications, or agreement pertaining or relating to any scheme or work of improvement or pertaining or relating to the furnishing of labor, materials, or equipment therefor, nor by any change or modification of any terms of payment or extension of the time for any payment pertaining or relating to any scheme of work of improvement, nor by any rescission or attempted rescission of the contract, agreement or bond, nor by any conditions precedent or subsequent in the bond attempting to limit the right of recovery of claimants otherwise entitled to recover under

any such contract or agreement, or under the bond, nor, where the bond is given for the benefit of claimants, by any fraud practiced by any person other than the claimant seeking to recover on the bond.

This bond shall inure to the benefit of any and all persons, companies and corporations entitled to file claims under the Civil Code so as to give them a right of action in a suit on this bond.

This bond is executed for the purpose of complying with the laws of the State of California and shall inure to the benefit of any of the persons named in Section 9100 of the Civil Code of the State of California.

IN WITNESS THEREOF, we have hereunto set our hands and seals this _____ day of _____, 20__.

(Corporate Seal)

Principal

By _____

Title

(Corporate Seal)

Principal

By _____

Title

APPROVED AS TO FORM:
/s/ Richard D. Jones
City Attorney

SUPPLEMENTAL INFORMATION TO BE COMPLETED BY PRINCIPAL

If an individual, so state. If a firm or co-partnership, state the firm and give the names of all individual co-partners composing the partnership. If a Corporation, state legal name of corporation; state also the names of the president, secretary, treasurer and manager thereof.

Business Address:

Telephone Number:

Date:

Print Name:

Principal

Signature:

Title

TAX IDENTIFICATION NUMBER

The Tax Equity and Fiscal Responsibility Act of 1982 requires the payer (City of La Habra) to report to the Internal Revenue Service taxable payments to payees.

You (as a payee) are required by law to provide us with your Taxpayer Identification Number (if an individual or partnership, your Social Security Number). If you do not provide us with your correct identification number, you may be subject to a penalty imposed by the Internal Revenue Service. The payments subject to withholdings may include, but are not limited to, interest, dividends, or other payments the City of La Habra and/or the La Habra Redevelopment Agency made to you. Other payments may include rents, royalties, commissions and fees for service of non-employees.

If you are exempt from income tax, we are still required, by law, to maintain a Tax Identification Number on file. **PLEASE PROVIDE YOUR TAX IDENTIFICATION NUMBER next to the appropriate listing below, sign, date and return to:**

CITY OF LA HABRA FINANCE DEPARTMENT
110 East La Habra Boulevard
La Habra, CA 90631

Exempt: Yes No Telephone () _____

CORPORATION: _____

U.S.A. OR ANY AGENCIES THEREOF: _____

IRS CODE #501 TAX-EXEMPT ORGANIZATION: _____

A NON-COMMISSIONED CITY OF LA HABRA EMPLOYEE: _____

SOLE PROPRIETOR: _____

A PARTNERSHIP: _____

OTHER: _____ (Explain)

Signature/Title: _____ Date: _____

BID GUARANTEE
TO THE CITY OF LA HABRA
PROJECT NO. _____

As a material inducement to the City to award the contract for Project No. _____ to _____, the undersigned ("Guarantor") has agreed to enter into this guarantee. The Guarantor hereby unconditionally guarantees to the fullest extent allowed by law the following work included in this project: _____ ("the work").

Guarantor guarantees that the materials and equipment used by itself and its subcontractors will be free from defects and that the work will conform to the plans and specifications. Should any of the materials or equipment prove defective or should the work as a whole, or any part thereof, prove defective for any reason whatsoever (except due to intentional torts by the City), or should the work as a whole or any part thereof fail to operate properly or fail to comply with the plans and specifications, Guarantor will, at the City's sole election: 1) reimburse the City, upon written demand, for all of the City's expenses incurred replacing or restoring any such equipment or materials, including the cost of any work necessary to make such replacement or repairs; or 2) replace any such defective material or equipment and repair said work completely, all without any cost to the City. Guarantor further guarantees that any such repair work will conform to the plans and specifications for the project. This guarantee will remain in effect for five years from the date on which the contracted for work is accepted for use by the City.

Guarantor understands and agrees that the City shall have the unqualified option to make any replacements or repairs itself or to have such replacement, repair, performed by the undersigned. The City shall have no obligation to consult with Guarantor before the City proceeds to perform any repair, replacement, or work itself. If the City elects to have Guarantor perform said repair, replacement, or work, Guarantor agrees that the repair, replacement, or work shall be performed within 15 days after receipt of a written demand from the City.

If the City elects to perform the replacement, repairs itself, Guarantor agrees to make reimbursement payment within 15 days after receipt of a written demand for payment from the City.

If the Guarantor fails or refuses to comply with this guarantee, the City shall be entitled to all costs and expenses, including attorneys and expert fees, reasonably incurred by reason of Guarantor's failure or refusal.

Guarantor _____ Date: _____

Contractor: _____ By: _____

Title: _____

STATEMENT OF NON COLLUSION BY CONTRACTOR

The undersigned who submits herewith to the City of La Habra a bid or proposal does hereby certify:

- a. That all statements of fact in such bid or proposal are true.
- b. That such bid or proposal was not made in the interest of or on behalf of any undisclosed person, partnership, company, association, organization or corporation.
- c. That such bid or proposal is genuine and not collusive or sham.
- d. That said bidder has not, directly or indirectly by agreement, communication or conference with anyone, attempted to induce action prejudicial to the interest of the City of La Habra or of any other bidder or anyone else interested in the proposed procurement.
- e. Did not, directly or indirectly, collude, conspire, connive or agree with anyone else that said bidder or anyone else would submit a false or sham bid or proposal, or that anyone should refrain from bidding or withdraw his bid or proposal.
- f. Did not in any manner, directly or indirectly seek by agreement, communication or conference with anyone to raise or fix the bid or proposal price of said bidder or of anyone else, or to raise or fix any overhead, profit or cost element of his bid or proposal price, or that of anyone else.
- g. Did not, directly or indirectly, submit his bid or proposal price or any breakdown thereof, or the contents thereof, or divulge information or data relative thereto, to any corporation, partnership, company, association, organization, bid depository, or to any member agent thereof, or to any individual or group of individuals, except to the City of La Habra, or to any person or persons who have a partnership or their financial interest with said bidder in his business.
- h. Did not provide, directly or indirectly to any officer or employee of the City of La Habra any gratuity, entertainment, meals, or anything of value, whatsoever, which could be objectively construed as intending to invoke any form of reciprocation or favorable treatment.
- i. That no officer or principal of the undersigned firm is related to any officer or employee of the city by blood or marriage within the third degree or is employed, either full or part time, by the City of La Habra either currently or within the last two (2) years.
- j. That no officer or principal of the undersigned firm nor any subcontractor to be engaged by the principal has been convicted by a court of competent jurisdiction of any charge of fraud, bribery, collusion, conspiracy or any other act in violation of any State or Federal antitrust law in connection with the bidding upon award of, or performance of, any public work contract, with any public entity, within the last three years.

I certify, under penalty of perjury under the laws of the State of California, that the foregoing is true and correct and that this certification was executed:

On _____ at _____ California.

Firm _____

Street _____

City _____ State _____ Zip _____

(Signature)

(Print Name & Title)

EXHIBIT A

SCOPE OF SERVICES

Customer/City of La Habra Responsibilities:

1. Complete access to the site for construction utilizing standard 2-wheel drive rubber tire equipment.
2. Locate existing underground utilities not covered by your local utilities. (i.e. water lines, electrical lines, irrigation systems, and sprinkler heads). Musco or Subcontractor will not be responsible for repairs to unmarked utilities.
3. Shut-off irrigation system at park at least one week prior to start of construction. Irrigation systems to remain off during construction timeframe.
4. Closer playing fields to activities from 6AM – 3PM, Monday-Friday, during project.
5. Provide geotechnical report for the site.
6. Pay for extra costs associated with foundation design that differs from the preliminary foundation design provided with this proposal once the geotechnical report has been provided; as well as excavation in non-standard soils (rock, caliche, high water table, collapsing holes, etc.) or soils not defined in geotechnical report.
7. Musco will submit plans to the City for plan check, and pull permits once plans are approved. City of Santa Ana to pay all plan check and permit fees, and any fees associated with special inspections.
8. Pay all SCE fees for new service at the park.
9. Provide laydown area on site for dumpsters, equipment containers, etc.

Musco Responsibilities:

1. Provide required foundations, poles, electrical enclosures, luminaires, wire harnesses, and control cabinets.
2. Provide layout of pole locations and aiming diagram.
3. Provide Project Management as required.
4. Provide stamped structural calculations and foundation designs based on soil parameters as outlined in the geotechnical report to be provided by the City. Provide special inspections from the geotechnical technical engineer during auguring of the foundations and backfill/concrete placement during foundation installation. Provide concrete cylinder testing to ensure concrete backfill is adequate strength prior to steel pole installation. If there are any other special inspections required, those are to be provided by the City.
5. Submit electrical and structural plans to the City Building Department for approval. City to pay cost of plan-check.
6. Assist our installing subcontractor and ensure our responsibilities are satisfied.

Musco Subcontractor Responsibilities

General:

1. Provide sealed Electrical Plans to include stamped foundation design and structural calculations.
2. Obtain required construction permits, City to pay cost of permits.
3. Contact 811 to locate underground public utilities and then confirm they have been clearly marked.
4. Contact the facility owner/manager to confirm the existing private underground utilities and irrigation systems have been located and are clearly marked to avoid damage from construction equipment. Notify owner and repair damage to marked utilities. Notify owner and Musco regarding damage which occurred to unmarked utilities.
5. Provide labor, equipment, and materials to offload equipment at jobsite per scheduled delivery.
6. Provide storage containers for material, (including electrical components enclosures), as needed.
7. Provide necessary waste disposal and daily cleanup.
8. Provide adequate security to protect the jobsite, and Musco delivered products from theft, vandalism, or damage during the installation.
9. Keep all heavy equipment off playing fields when possible, provide ground protection as needed to minimize damage to existing grounds. Repair damage to grounds which exceeds that which would be expected.

Quote

Indentations caused by heavy equipment traveling over dry ground would be an example of expected damage. Ruts and sod damage caused by equipment traveling over wet grounds would be an example of damage requiring repair.

10. Provide startup and aiming as required to provide complete and operating sports lighting system.
11. Installation to commence upon delivery and proceed without interruption until complete. Notify Musco immediately of any breaks in schedule or delays.
12. Ground restoration over trenches to match adjacent landscape/turf.

Foundations, Poles, and Luminaires:

1. Mark and confirm pole locations per the aiming diagram provided. If there are any issues, immediately notify your Musco Project Manager.
2. Provide labor, materials, and equipment to install (5) LSS foundations as specified on Layout and per the stamped foundation drawings.
3. Remove spoils from site.
4. Provide labor, materials, and equipment to assemble (28) Musco TLC-LED luminaires, electrical component enclosures, poles, and pole harnesses.
5. Provide labor, equipment, and materials to install (5) dressed/assembled LSS Poles and aim utilizing the pole alignment beam.

Electrical:

1. Provide labor (prevailing wages), materials, and equipment to install new:
 - a. Concrete pad for installation of new switchgear enclosure
 - b. Stainless Steel Strongbox 200A 480/277v Pedestal (65KAIC)
 - c. 10 KVA 277-120/240 Step Down Transformer
 - d. 72x72x24 Hoffman NEMA 3R Enclosure to house Control-Link lighting controls cabinet
2. Provide labor, materials, and equipment to install all underground conduit, wiring, pull boxes etc. and terminate wiring as required for the sports lighting and area lighting.
3. Provide as-built drawings on completion of installation.

Control System:

1. Provide labor, equipment, and materials to install Musco control and monitoring cabinet(s) inside new Hoffman NEMA 3R enclosure and terminate all necessary wiring.
2. Provide a dedicated 120 V 20 A controls circuit or a step-down transformer for 120 V control circuit if not available.
3. Check all zones to make sure they work in both auto and manual mode.
4. Commission Control-Link® by contacting Control-Link Central™ at 877-347-3319.

PRELIMINARY FOUNDATION AND POLE ASSEMBLY DRAWING

TABLE 1: POLE ASSEMBLY

POLE ID	POLE HEIGHT ft (m)	# OF LUMINAIRES	ASSEMBLED POLE WEIGHT ¹ lb (kg)
A1	60 (18.3)	4	1037 (470)
A2	60 (18.3)	4	1037 (470)
A3	60 (18.3)	5	1126 (511)
B1	70 (21.3)	10	2128 (965)
B2	70 (21.3)	5	1552 (704)

Pole Assembly Notes:

- Steel pole should overlap concrete base and be sealed light with 1/2 ton come-alongs (connector provided).
- Align weldmarks on steel sections before assembling.
- Assembled pole weight includes steel sections, crossarms, luminaires, and electrical components enclosures. If pole has stamped structural design then use pole weight (listed as vertical force) on stamped structural design document.
- Section overlap must be pulled together until light. Overlap measurement should be +/- 6 in (150 mm).
- This document is not intended for use as an assembly instruction. See *Installation Instructions: Light-Structure System™* Lighting System for complete assembly procedure.

TABLE 2: FOUNDATION DETAILS

POLE ID	CONCRETE BASE WEIGHT lb (kg)	BURIAL INFORMATION ^{1,2} C (ft) / H (m) CONCRETE BACKFILL ^{1,2} yp ³ (m ³)	CUT BASE	LIGHTNING GROUND ³ SUPPLEMENTAL INSTRUCTION	
				TYPE	N/A
A1	1870 (846)	30 (762) 10 (3.0) 1.2 (0.9)	NO	INTEGRATED ⁴	N/A
A2	1870 (846)	30 (762) 10 (3.0) 1.2 (0.9)	NO	INTEGRATED ⁴	N/A
A3	1870 (846)	30 (762) 10 (3.0) 1.2 (0.9)	NO	INTEGRATED ⁴	N/A
B1	2740 (1243)	30 (762) 12 (3.7) 1.5 (1.1)	NO	INTEGRATED ⁴	N/A
B2	2740 (1243)	30 (762) 12 (3.7) 1.5 (1.1)	NO	INTEGRATED ⁴	N/A

Foundation Notes:

- Concrete backfill is calculated to 2 ft (0.6m) below grade (no average indicated). Top 2 ft (0.6m) to be class 5 soil compacted to 95% density of surrounding undisturbed soil unless otherwise specified in stamped structural design.
- Concrete backfill required 3000 lb/ft³ (23 MPa) minimum.
- Foundation design per 2022 CBC, 95 mph, exposure category C, variation STD.
- Assumes IBC class 5 soils.
- Standard bases include integrated lightning protection. If bases are cut, supplemental lightning protection is required. Contact Musco for materials and instruction.
- Lighting protection is a manufacturer installed concrete encased electrode and connector. Ground connection is made when concrete base is installed and footing is poured. No additional steps required.

This is a preliminary foundation design used for installation pricing and is not intended to be used for construction. Musco will provide a stamped foundation design by a State of California licensed structural engineer once a soils report is received. If soil conditions dictate a different foundation design than indicated on this preliminary design, a change order will be provided for the difference in costs.

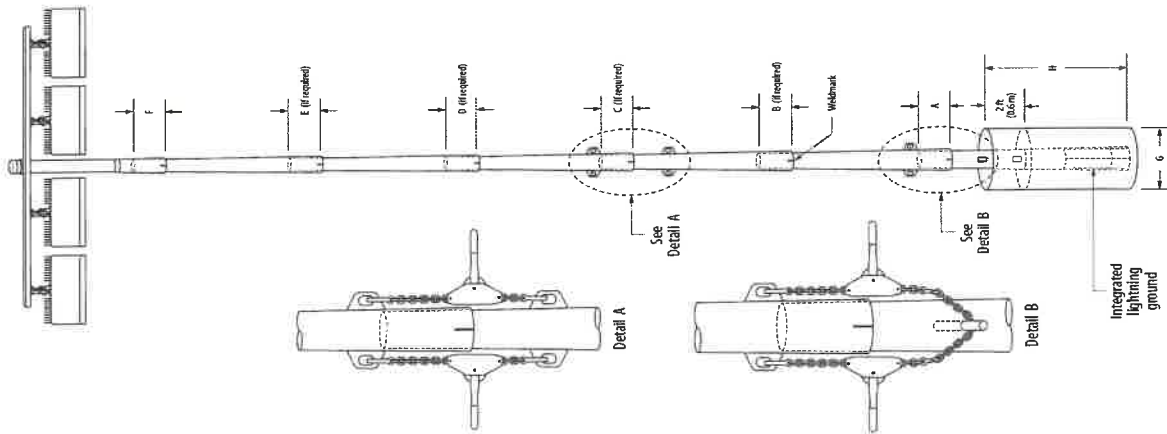

160-60-00-004-01_B



System Requirements: Control System Summary

Project Name: Portola Park | Project #: 200920

Control System ID: 1 of 1

Distribution Panel Location/ID: Service 1

Project Information

Control System

Control System ID: 1201
 Control System Type: Control-Link Control and Monitoring System
 Communication Type: PowerLine-ST

Project Notes:

Prelim Control Summary
 LED C&M
 480V/3P
 Powerline Comm
 120V Control

Power Requirements

Control cabinet(s):
 Control voltage (phase to neutral) 120/60
 VA loading - Inrush 2043.0
 VA loading - Sealed 232.0

Lighting Circuits:

Voltage/Hertz/Phase 480/60/3

Equipment Listing

Description	Qty	Size (in)
Control and monitoring cabinet - primary	1	24 X 48
Contactors, 30 amperes	6	-
Off/On/Auto switches	2	-

Important Notes:

- Please confirm that the lighting circuit voltage listed above is accurate for this facility. This is the voltage/phase being connected and utilized at each lighting pole's electrical components enclosure disconnect. Inaccurate voltage/phase can result in additional costs and delays. Contact your Musco sales representative to confirm this item.
- In a 3 phase design, all 3 phases are to be run to each pole location. Musco's single phase luminaires come pre-wired to utilize all 3 phases across the entire facility.
- One contactor is required for each circuit at each pole location. Contactors are 3 pole and 100% rated for the published continuous load.
- If the lighting system will be fed from more than one distribution location, additional equipment may be required. Contact your Musco sales representative.
- Size overcurrent devices using the full load amps column of the Circuit Summary by Switch chart (Minimum power factor is 0.9). Size conduit per code unless otherwise specified as larger to allow for harness connectors.
- Avoid use of in-ground junction/pull boxes when possible. If used, the following best practices must be followed:
 - Underground handholes (pull boxes) must be supported to prevent settling. Boxes buried directly in soil, without support, are not allowed.
 - Use polymer concrete lids marked with ELECTRIC for underground handholes. Steel lids are not allowed.
 - Avoid underground connections when possible. If used, all wire connectors must be UL listed for Wet Locations to prevent leakage current.
- Control power wiring must be in separate conduit from line or load power wiring. Communication cables must be in separate conduit from any power wiring.
- Test wire per ANSI/NETA ATS-2021. Wires with insulation resistance less than 100 MOhms, in water-filled conduit, must be replaced.
- Refer to Installation Instructions for more details on equipment information and the installation requirements.

System Requirements: Control System Summary

Project Name: Portola Park | Project #: 200920

Control System ID: 1 of 1

Distribution Panel Location/ID: Service 1

Equipment Layout and Connection Details



Lighting system

Control cabinet location(s)

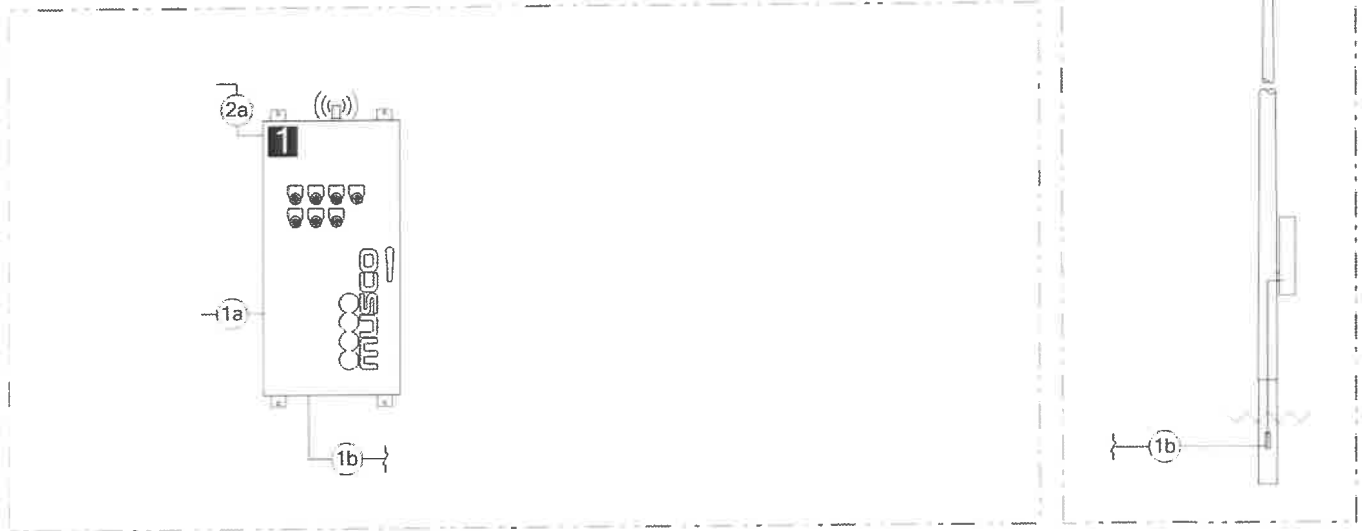

Connection Details

Equipment

ID	Description
1a	Line power to contactors, and equipment grounding conductor. Requires one circuit per contactor, size wiring per load and voltage drop.
1b	Load power from contactors, and equipment grounding conductor. Requires one circuit per contactor, size wiring per load and voltage drop.
2a	Control power with equipment ground to control cabinet. Requires dedicated 20 A circuit. Provide transformer if control voltage not present.

ID	Description
1	Control and monitoring cabinet - primary

System Requirements: Control System Summary

Project Name: Portola Park | Project #: 200920

Control System ID: 1 of 1

Distribution Panel Location/ID: Service 1

Circuit Summary

Switching Schedule

Field/Switch Description	Switches
Baseball	1
Little League	2

Control Module ID: 1

Lighting Circuit Voltage: 480/60/3

Circuit Summary by Switch

Switch	Zone Description	Pole ID	Qty of Fixtures	Full load amperes	Contactor Size (Amps)	Cabinet #	Contactor ID
1	Baseball	A1	4	5.17	30	1	C1
	Baseball	A2	4	5.17	30	1	C2
	Baseball	B1	5	7.01	30	1	C3
	Baseball	B2	5	7.77	30	1	C4
2	Little League	A3	5	7.13	30	1	C5
	Little League	B1	5	7.77	30	1	C6



© 2013 Musco Lighting, Inc. All rights reserved. Photo by Tommaso De Luca



© 2013 Musco Lighting, Inc. All rights reserved. Photo by Tommaso De Luca



© 2013 Musco Lighting, Inc. All rights reserved. Photo by Tommaso De Luca



© 2013 Musco Lighting, Inc. All rights reserved. Photo by Tommaso De Luca

Portola Park La Habra, CA



Sales Representative: M. Marchetti - Designer: E. Fox - Design No.: 2009208 - June 30, 2015

All in the registered in La Habra, CA. All without the written consent of Musco Lighting, Inc. © 2015 Musco Lighting, Inc.

Portola Park
La Habra, CA

LIGHTING SYSTEM

Structure/Fixture Summary

Structure ID	Structure Height	Fixt. Attachment Ht.	Fixture Qty	Fixture Type	Design Level	Circuit
A1A2	60'	18'	1	TLC-LED-900	2.64 kW	A
A3	60'	18'	1	TLC-91-575	0.57 kW	A
B1	70'	18'	1	TLC-LED-1200	1.18 kW	B
B1	70'	18'	1	TLC-LED-900	2.64 kW	B
B1	70'	18'	1	TLC-91-575	0.57 kW	B
B1	70'	18'	1	TLC-LED-550	0.53 kW	A
B1	70'	18'	1	TLC-LED-900	0.88 kW	A
B1	70'	18'	2	TLC-LED-1200	2.33 kW	A
B1	70'	18'	3	TLC-LED-900	2.64 kW	B
B1	70'	18'	1	TLC-91-575	0.57 kW	A
B1	70'	18'	1	TLC-91-575	0.57 kW	B
B2	70'	18'	2	TLC-LED-1200	2.33 kW	A
B2	70'	18'	2	TLC-LED-900	1.76 kW	A
B2	70'	18'	1	TLC-91-575	0.57 kW	A
B2	70'	18'	28	TLC-91-575	24.17 kW	A

* Fixtures in this design have dimmed output values to meet design-specific needs.

Circuit Summary

Circuit	Description	Design Level	Fixture Qty
A	Baseball	15.41 kW	18
B	Little League	8.75 kW	10

Fixture Type Summary

Type	Circuit	Avg. Wattage	Avg. Lumens	Qty	Design Level	Quantity
TLC-91-575	A	575W	52,051	180	>120,000	4
TLC-91-575	B	575W	52,051	>120,000	>120,000	2
TLC-LED-1200	A	1,183W	127,246	>120,000	>120,000	2
TLC-LED-1200	B	1,183W	127,246	>120,000	>120,000	2
TLC-LED-900	A	880W	96,166	>120,000	>120,000	1
TLC-LED-900	B	880W	96,166	>120,000	>120,000	6
TLC-LED-500	A	880W	96,166	>120,000	>120,000	1

Single Fixture Amperage Draw Chart

Fixture Specifications (30 min. driver factor)	Line Amperage Per Fixture
Single Phase Voltage	240
TLC-LED-1200	200 (60)
TLC-LED-900	6.0 (60)
TLC-91-575	5.2 (60)
TLC-LED-500	3.9 (60)
TLC-LED-500	2.5 (60)
TLC-91-575	2.4 (60)
TLC-LED-500	1.9 (60)
TLC-LED-500	1.8 (60)
TLC-91-575	1.5 (60)
TLC-LED-500	1.4 (60)

* Amp draw based on 100% fixture output, consult design specific datasheet for adjusted amperage draw chart

Light Level Summary

Grid Name	Calculation Metric	Min	Max	Avg/ft²	Circuits	Fixture Qty
Baseball (Infield)	Horizontal Illuminance	50.35	38	1.72	A	18
Baseball (Outfield)	Horizontal Illuminance	30.12	19	2.27	A	18
Little League (Infield)	Horizontal Illuminance	38.34	24	2.40	B	10
Little League (Outfield)	Horizontal Illuminance	18.48	10	2.95	B	10
Soil @ 3ft	Horizontal Illuminance	0.2685	0.00	3.95	A,B	28
Soil @ 5ft	Max Candela Metric	2966.3813	0.00	37779.16	A,B	28
Soil @ 5ft	Max Vertical Illuminance Metric	0.3384	0.00	5.05	A,B	28

Guaranteed Performance: The ILLUMINATION described above is guaranteed per your Musco Warranty document.

Field Measurements: Individual field measurements may vary from computer-calculated predictions.

Electrical System Requirements: Refer to Amperage Draw Chart and/or the "Musco Control System Summary" for electrical string.

Installation Requirements: Results assume ±3% nominal voltage at the side of the driver and structures located within 3 feet (1m) of design locations.



Portola Park

La Habra, CA

Grid Summary

Name: Little League
 Size: Irregular 145'x151'x140'
 Spacing: 20.0' x 20.0'
 Height: 3.0' above grade

Illumination Summary

MOUNTED HORIZONTAL FOOTCANDLES	
	Outfield
Guaranteed Average:	50
Scan Average:	38.34
Minimum:	57
Maximum:	29
Avg/Min:	1.52
Guaranteed Max/Min:	2 / 2.5
Max/Min:	2.40 / 1.95
UG (adjacent pts):	1.35 / 1.65
CU:	0.64
No. of Points:	25
Applied Circuits:	0
No. of Fixtures:	30
Total Load:	8.75 kW

Guaranteed Performance: The ILLUMINATION described above is guaranteed per your Musco Warranty document.
Field Measurements: Individual field measurements may vary from computer-calculated predictions.
Electrical System Requirements: Refer to Appendix Draw Chart and/or the "Musco Control System Summary" for electrical sizing.
Installation Requirements: Results assume ±3% accuracy. All structures located within 5 feet (1.5m) of design locations.

Equipment List For Areas Shown

QTY	STRUCTURE #	SIZE	GRADE ELEVATION	ABOVE FIELD LEVEL	FITTURE TYPE	OTHER	
						THIS	OTHER
1	A3	60"		60"	TLC-LED-3200	1	0
				60"	TLC-LED-900	3	0
				15.5'	TLC-8T-575	1	0
1	B1	70"		70"	TLC-LED-3200	2/1*	0
				70"	TLC-LED-900	1/1*	0
				15.5'	TLC-8T-575	2	1
2					TLC-8T-575	15	10
					Totals:	15	10

Above Field Level is height of fixtures above area shown
 *This structure utilizes a back-to-back mounting configuration

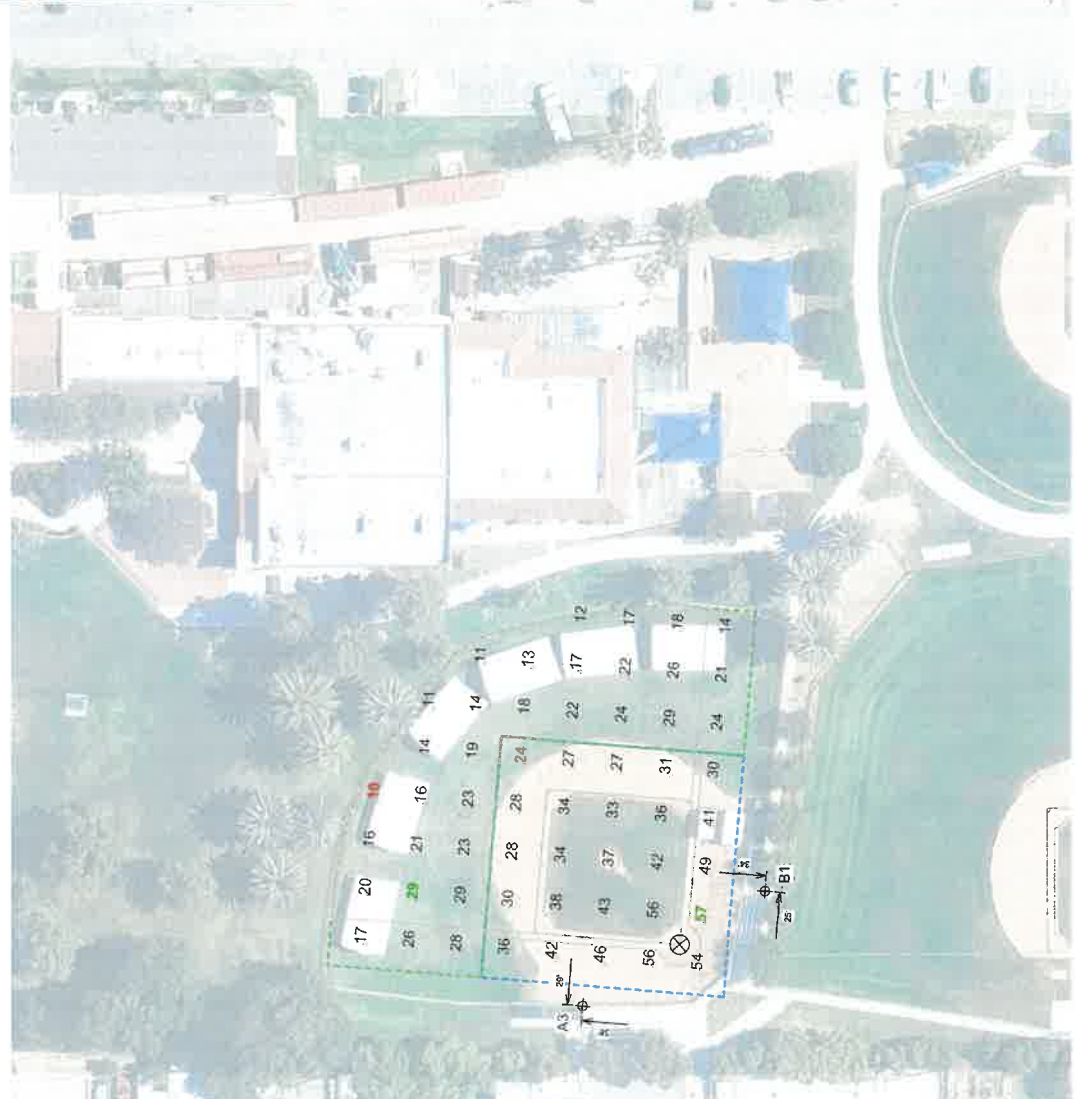

Pole location(s) dimensions are relative to 0.0 reference point(s)



ENGINEERED DESIGN By: E.Fox • File #Z009208 • 30-Jun-25



Not to be reproduced in whole or in part without the written consent of Musco Sports Lighting, LLC. ©1983 - 2025 Musco Sports Lighting, LLC.

ILLUMINATION SUMMARY

Portola Park La Habra, CA

Grid Summary

Name: 1011 @ 5/1
Spacing: 30.0'
Height: 5.0' above grade

ILLUMINATION SUMMARY

Entire Grid	
Scan Average:	2966.8243
Maximum:	37779.16
Minimum:	0.00
CU:	0.01
No. of Points:	98
Applied Circuits:	A, B
No. of Fixtures:	28
Total Load:	24.17 kW

Guaranteed Performance: The ILLUMINATION described above is guaranteed per your Musco Warranty document.

Field Measurements: Individual field measurements may vary from computer-calculated predictions.

Electrical System Requirements: Refer to Amperage Draw Chart and/or the "Musco Control System Summary" for electrical sizing.

Installation Requirements: Results assume ± 3% nominal voltage at line side of the driver and structures located within 3 feet (1m) of design locations.

Equipment List for Areas Shown

QTY	STRUCTURE ID	SIZE	GRADE ELEVATION	MONO LEVEL	FIXTURE TYPE	COMPPOSE	THIS END	OTHER ENDS	
2	A1-A2	60"	-	60"	TLC-LED-900	3	3	0	
			15.5'		TLC-R1-575	1	1	0	
1	A3	60"	-	60"	TLC-LED-1200	3	3	0	
			15.5'		TLC-LED-900	3	3	0	
			15.5'		TLC-R1-575	2	2	0	
1	B1	70"	-	70"	TLC-LED-900	2	2	0	
			15.5'		TLC-LED-500	1/2*	1/2*	0	
			15.5'		TLC-R1-575	2	2	0	
1	B2	70"	-	70"	TLC-LED-1200	2	2	0	
			15.5'		TLC-LED-900	2	2	0	
5					TLC-R1-575	1	1	0	
Totals:							28	28	0

Above Field Level is height of fixtures above area shown

*This structure utilizes a back-to-back mounting configuration



Pole location(s) dimensions are relative to 0,0 reference point(s)



ENGINEERED DESIGN By: E.Fox • File #2009208 • 30-Jun-25



Not to be reproduced in whole or part without the written consent of Musco Sports Lighting, LLC. ©1981, 2025 Musco Sports Lighting, LLC.

ILLUMINATION SUMMARY

Portola Park

La Habra, CA

Grid Summary

Name: Split @ 3ft
 Spacing: 30.0'
 Height: 5.0' above grade

ILLUMINATION SUMMARY

Entire Grid
 Scan Average: 0.3384
 Maximum: 5.05
 Minimum: 0.00
 CU: 0.01
 No. of Fixtures: 36
 Applied Circuits: A, B
 No. of Fixtures: 28
 Total Load: 24.17 KW

Guaranteed Performance: The ILLUMINATION described above is guaranteed per your Musco Warranty document.

Field Measurements: Individual field measurements may vary from computer-calculated predictions.

Electrical System Requirements: Refer to Ampage Draw Chart and/or the "Musco Control System Summary" for electrical sizing.

Installation Requirements: Results assume 4.3% nominal voltage at line side of the driver and structures located within 3 feet (1m) of design locations.

Equipment List for Areas Shown

QTY	STRUCTURE ID	SIZE	BRAND	HEIGHT	FIXTURE TYPE	CONTROL	THIS GRID	OTHER GRIDS
2	A1-A2	60"	-	60"	TLC-LED-900	3	3	0
1	A3	60"	-	15.5'	TLC-BT-575	1	1	0
1	B1	70"	-	60"	TLC-LED-900	3	3	0
1	B2	70"	-	15.5'	TLC-BT-575	2	2	0
5	Totals					28	28	0

Above Field Level is height of fixtures above areas shown

*This structure utilizes a back-to-back mounting configuration



Pole location(s) dimensions are relative to 0.0 reference point(s)

SCALE IN FEET 1: 120



ENGINEERED DESIGN By: E. Fox • File #200920B • 30-Jun-25



Not to be reproduced, in whole or in part, without the written consent of Musco Sport Lighting, LLC.
 © 2024, 2025 Musco Sport Lighting, LLC.

ILLUMINATION SUMMARY

Portola Park La Habra, CA

Equipment Layout

INCLUDES:

- Little League
- Little League

Electrical System Requirements: Refer to Amperage Draw Chart and/or the "Musco Control System Summary" for electrical sizing.

Installation Requirements: Results assume ± 3% tolerance. All structures located within ± feet (1m) of design locations.

Equipment List For Areas Shown

QTY	STRUCTURE ID	STRUCTURE SIZE	GLOBAL ELEVATION	MOUNTING GLOBAL LEVEL	FITTINGS	
					PICTURE TYPE	OPTIONAL
2	A1-A2	60"	-	60"	TLC-LED-900	3
				15.5'	TLC-8T-575	1
1	A3	60"	-	60"	TLC-LED-1200	1
				15.5'	TLC-8T-575	1
1	B1	70"	-	70"	TLC-LED-1200	2/1*
				15.5'	TLC-LED-900	1/3*
1	B2	70"	-	70"	TLC-LED-1200	2
				15.5'	TLC-8T-575	2
5					TLC-8T-575	1
					TLC-8T-575	28

*This structure utilizes a back-to-back mounting configuration Above Global Level is height of fixtures above design (0,0,0)

Single Fixture Amperage Draw Chart

Fixture Type	Line Amperage Per Fixture (50' with package fixture)									
	208' (60)	210' (60)	240' (60)	277' (60)	347' (60)	360' (60)	480' (60)	500' (60)	600' (60)	660' (60)
Single Phase Voltage	6.9	6.5	6.0	5.2	4.2	3.8	3.0	2.3	1.9	1.5
TLC-LED-1200	5.2	4.9	4.5	3.9	3.1	2.9	2.3	1.8	1.4	1.1
TLC-LED-900	3.3	3.2	2.9	2.5	2.0	1.8	1.5	1.1	0.9	0.7
TLC-8T-575	3.2	3.0	2.8	2.4	1.9	1.8	1.4	1.1	0.8	0.6

*Amp draw based on 100% fixture output, consult design specific datasheet for adjusted amperage draw chart

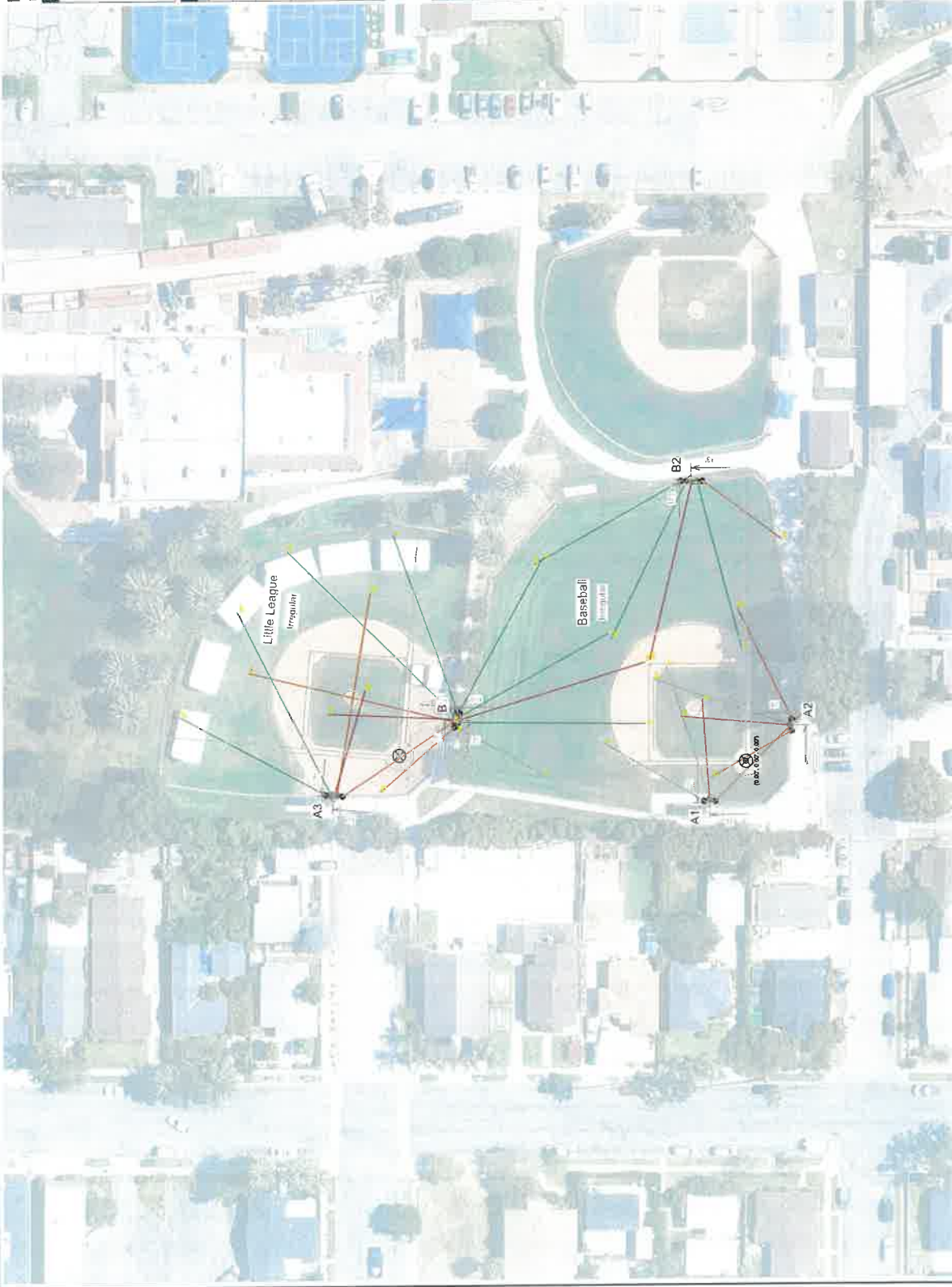

SCALE IN FEET 1 : 60
0 60 120'

ENGINEERED DESIGN By: E. Fox • File #200920B • 30-Jun-25

Pole location(s) dimensions are relative to 0,0 reference point(s)



Not to be reproduced in whole or part without the written consent of Musco Sports Lighting, LLC.
©1991, 2025 Musco Sports Lighting, LLC.

EQUIPMENT LAYOUT

EXHIBIT B
INSURANCE REQUIREMENTS
Portola Park Lighting Project 2025

Contractor shall maintain and shall require all of its subcontractors, consultants, and other agents to maintain the insurance listed below. Any requirement for insurance to be maintained after completion of the work shall survive this agreement.

CITY reserves the right to review any and all of the required insurance policies and/or endorsements, but has no obligation to do so. Failure to demand evidence of full compliance with the insurance requirements set forth in this agreement or failure to identify any insurance deficiency shall not relieve Contractor from, nor be construed or deemed a waiver of, its obligation to maintain the required insurance at all times during the performance of this agreement.

A. Workers Compensation & Employers Liability Insurance

The Contractor shall procure and maintain Worker's Compensation Insurance as required by applicable state or territorial law for all of his employees to be engaged in work at the site of the project under this Contract. In case of any such work sublet, the Contractor shall require the subcontractor similarly to provide Worker's Compensation Insurance for all of the latter's employees to be engaged in such work unless such employees are covered by the protection afforded by the Contractor's Worker's Compensation Insurance. In case any class of employees engaged in hazardous work on the project under this Contract is not protected under the Worker's Compensation Statute, the Contractor shall provide and shall cause each subcontractor to provide adequate employer's liability insurance for the protection of such of his employees as are not otherwise protected.

The Contractor and/or subcontractor shall file a copy of their Certificate of Compensation Insurance with the CITY and no work shall begin until such certificate is filed with the CITY. In the event of cancellation, the insurance company shall give the CITY ten (10) days written notice.

- Workers Compensation insurance with statutory limits as required by the Labor Code of the State of California.
- Employers Liability with limits of \$1,000,000 per Accident; \$1,000,000 Disease per employee; \$1,000,000 Disease per policy.
- The policy shall include a written waiver of the insurer's right to subrogate against CITY.
- Required Evidence of Coverage:
 1. Subrogation waiver endorsement; and
 2. Properly completed Certificate of Insurance.

B. General Liability Insurance

- Commercial General Liability Insurance no less broad than Insurance Services Office (ISO) form CG 00 01.

- Coverage shall be on a standard occurrence form. Claims-Made forms are not acceptable without prior written consent. Modified, limited or restricted Occurrence forms are not acceptable without prior written consent.
- Minimum Limits: \$2,000,000 per Occurrence; \$4,000,000 General Aggregate; \$4,000,000 Products/Completed Operations Aggregate. The General Aggregate shall apply separately to each project. The required limits may be provided by a combination of General Liability Insurance and Commercial Excess or Umbrella Liability Insurance. If contractor maintains higher limits than the specified minimum limits, CITY requires and shall be entitled to coverage for the higher limits maintained by contractor.
- Any deductible or self-insured retention shall be shown on the Certificate of Insurance. If the deductible or self-insured retention exceeds \$25,000 it must be approved in advance by CITY. Contractor is responsible for any deductible or self-insured retention and shall fund it upon CITY'S written request, regardless of whether Contractor has a claim against the insurance or is named as a party in any action involving CITY.
- Coverage shall be continued for one (1) year after completion of the work.
- CITY shall be endorsed as an additional insured for liability arising out of ongoing and completed operations by or on behalf of the contractor. CITY shall continue to be an additional insured for completed operations for (1) year after completion of the work.
- The policy definition of "insured contract" shall include assumptions of liability arising out of both ongoing operations and the products-completed operations hazard ("f" definition of insured contract in ISO form CG 00 01, or equivalent).
- The insurance provided to the additional insureds shall be primary to, and non-contributory with, any insurance or self-insurance program maintained by them.
- The policy shall cover inter-insured suits and include a "Separation of Insureds" or "severability" clause which treats each insured separately.
- The policy shall be endorsed to include a written waiver of the insurer's right to subrogate against all persons or entities that are, or are required to be, additional insureds.
- The policy shall not contain a Contractors' Warranty or other similar language which eliminates or restricts insurance because of a subcontractor's failure to carry specific insurance or to supply evidence of such insurance.
- Required Evidence of Coverage:
 - Copy of the additional insured endorsement or policy language granting additional insured status;
 - Copy of the endorsement or policy language indicating that coverage applicable to the additional insureds is primary and non-contributory;
 - Properly completed Certificate of Insurance; and
 - Completed and signed Agent/Broker Questionnaire with supporting documentation as required.

C. Automobile Liability Insurance

- Minimum Limit: \$2,000,000 combined single limit per accident.
- Coverage shall apply to all owned, hired and non-owned vehicles.
- CITY shall qualify as an insured.
- Required Evidence of Coverage:

Project No CS-2025-102

- Copy of the endorsement or policy language indicating that CITY is an insured;
and
- Properly completed Certificate of Insurance.

D. Surety Bonds

- Bid bond.
- Performance and payment bonds for the entire contract price.
- The surety must be authorized to issue these bonds in the State of California.

E. Standards for Insurance Companies

- Insurers, other than the California State Compensation Insurance Fund, shall have an A.M. Best's rating of at least A:VII.

F. Documentation

- The Certificate of Insurance shall include the following reference: City of La Habra
- The name and address for Additional Insured endorsements and Certificates of Insurance is: City of La Habra
- Contractor shall provide immediate written notice if: (1) any of the required insurance policies is terminated; (2) the limits of any of the required policies are reduced; or (3) the deductible or self-insured retention is increased.
- Current Evidence of Coverage shall be provided for the entire required period of insurance.
- Upon written request, certified copies of required insurance policies shall be provided within thirty (30) days.