

MIL-S-11030F
14 September 1990
SUPERSEDING
MIL-S-11030E
2 July 1976

MILITARY SPECIFICATION

SEALING COMPOUND, SINGLE-COMPONENT, NON-CURING, POLYSULFIDE BASE

This specification is approved for use by all Departments and Agencies of the Department of Defense.

1. SCOPE

1.1 Scope. This specification covers single-component black, inert, thermoplastic, mastic, non-curing, sealing compounds. These sealing compounds are not to be used as an integral fuel tank or pressure cabin standards. The service temperature of the sealing compounds are -40°C to 82°C (-40° to 180°F) (see 6.1).

1.2 Classification. Sealing compound shall be furnished in the following types:

- Type I - For static sealing of metal, glass, Polyacrylic plastics to each other and in combinations with each other.
- Type II - For rotary sealing of metal to metal having a cone penetration of approximately 200.
- Type III - Extruded tape (see 3.1.3).

2. APPLICABLE DOCUMENTS

2.1 Government documents.

2.1.1 Specifications, standards, and handbooks. The following specifications, standards, and handbooks form a part of this document to the extent specified herein. Unless otherwise specified, the issues of these documents are those listed in the issue of the Department of Defense Index of Specifications and Standards (DODISS) and supplement thereto, cited in the solicitation (see 6.2).

SPECIFICATIONS

FEDERAL

- O-S-595 - Sodium Dichromate, Dihydrate, Technical
- O-S-809 - Sulfuric Acid, Technical

Beneficial comments (recommendations, additions, deletions) and any pertinent data which may be of use in improving this document should be addressed to: Director, U.S. Army Laboratory Command, Materials Technology Laboratory, ATTN: SLCMT-MEE, Watertown, MA 02172-0001 by using the Standardization Document Improvement Proposal (DD Form 1426) appearing at the end of this document or by letter.

MIL-S-11030F

- QQ-A-250/5 - Aluminum Alloy Alclad 2024, Plate and Sheet
- TT-S-735 - Standard Test Fluids, Hydrocarbon
- PPP-B-601 - Boxes, Wood, Cleated Plywood
- PPP-B-636 - Box, Shipping, Fiberboard, Wood-Cleated
- PPP-C-96 - Can, Metal, 28 Gage and Lighter

MILITARY

- MIL-C-38736 - Compound, Solvent, For Use In Integral Fuel Tanks
- MIL-G-23827 - Grease, Aircraft and Instruments, Gear and Actuator Screw
- MIL-P-8184 - Plastic Sheet, Acrylic, Modified

STANDARDS

FEDERAL

- FED-STD-313 - Material Safety Data Sheets, Preparation and the Submission Of

MILITARY

- MIL-STD-105 - Sampling Procedures and Tables for Inspection by Attributes
- MIL-STD-129 - Marking for Shipment and Storage
- MIL-STD-1190 - Minimum Guidelines for Level C Preservation, Packing and Marking
- MIL-STD-2073 - DoD Material Procedure for Development and Application of Packaging Requirements

(Unless otherwise indicated, copies of federal and military specifications, standards, and handbooks are available from the Standardization Documents Order Desk, Bldg. 4D, 700 Robbins Avenue, Philadelphia, PA 19111-5094.)

UNIFORM CLASSIFICATION COMMITTEE AGENT

Uniform Freight Classification Rules

(Application for copies should be addressed to the Uniform Classification Committee, Rm 1106, 222 South Riverside Plaza, Chicago, IL 60606.)

NATIONAL MOTOR FREIGHT TRAFFIC ASSOCIATION INC., AGENT

National Motor Freight Classification Rules

(Application for copies should be addressed to the American Trucking Association, Inc., ATTN: Traffic Order Section, 2200 Mill Road, Alexandria, VA 22314.)

2.2 Non-Government publications. The following documents form a part of this specification to the extent specified herein. Unless otherwise specified, the issues of the documents which are DoD adopted are those listed in the issue of the DODISS cited in the solicitation. Unless otherwise

specified, the issues of documents not listed in the DODISS are the issues of the documents cited in the solicitation (see 6.2).

AMERICAN SOCIETY FOR TESTING AND MATERIALS (ASTM)

- ASTM D217 - Cone Penetration of Lubricating Grease
- ASTM D471 - Rubber Property - Effect of Liquids
- ASTM D897 - Tensile Properties of Adhesive Bonds
- ASTM D4397 - Polyethylene Sheeting for Construction Industrial, and Agricultural Applications
- ASTM E437 - Industrial Wire Cloth and Screens (Square Opening Series)

(Application for copies should be addressed to American Society for Testing and Materials, 1916 Race Street, Philadelphia, PA 19103).

(Non-Government standards and other publications are normally available from the organizations that prepare or distribute the documents. These documents also may be available in or through libraries or other informational services.)

2.3 Order of precedence. In the event of a conflict between the text of this document and the references cited herein, the text of this document takes precedence. Nothing in this document, however, supersedes applicable laws and regulations unless a specific exemption has been obtained.

3. REQUIREMENTS

3.1 Material.

3.1.1 Type I. Type I sealing compound shall be a non-curing mastic organic polysulfide polymer. The sealing compound shall be homogeneous, stable, and noncorrosive.

3.1.2 Type II. Type II sealing compound shall consist of 7.0 parts (by weight) of type I sealing compound plus 2.0 parts (by weight) of grease as specified in MIL-G-23827 (see 4.5.13).

3.1.3 Type III. Type III sealing compound shall be of the same consistency and as specified in 3.1.1 except for the following: Type III sealing compound shall be in tape form 0.05 in. (1.1 mm) thick by 1.5 in. (38 mm) wide applied to a suitable release paper. Approximately 50 feet (15 m) of the tape shall be rolled on fiberboard cores having an inside diameter of approximately 3 in. (76 mm).

3.2 Volatile content. The volatile content of Type I and Type III sealing compound shall be not greater than 1.5 percent when tested as specified in 4.5.1. There is no requirement for Type II compound.

3.3 Water solubility. The water solubility of Type I and Type III sealing compound shall be not greater than 0.4 percent when tested as specified 4.5.2. There is no requirement for Type II compound.

3.4 Oil resistance. Type I and type III sealing compound shall show no evidence of blistering, softening, or loss of adhesion when exposed to mineral

oil and tested as specified in 4.5.3. There is no oil resistance requirement for Type II sealing compound.

3.5 Adhesion. Type I and type III sealing compound shall have a bond strength of not less than 25 psi (1.75 kg/cm²). Failure shall occur only in the sealing material itself when tested as specified in 4.5.4. Type II sealing compound has no adhesion requirements.

3.6 Aging. When tested as specified in 4.5.5, the sealing compound shall show a cone penetration before and after aging as specified in table I.

3.7 Effect of volatile compounds. For type I and type III, there shall be no evidence of chemical attack such as crazing, pitting or etching on the surface of poly (methyl methacrylate) when exposed to volatile components of freshly prepared sealing compound and tested as specified in 4.5.6. There is no requirement for type II.

TABLE I. Cone Penetration.

	Types I and III	Type II
Depth of cone penetration before aging in 1/10 mm	40-80	150-250
Change in cone penetration after aging in 1/10 mm	20 max.	40 max.

3.8. Crazing on stressed acrylic plastic. Type I and type III sealing compound shall not cause crazing or cracking of acrylic plastic under stress when tested as specified in 4.5.7.

3.9 Low temperature flexibility. Type I and type III sealing compound shall show no evidence of cracking or loss of adhesion when subjected to flexing at $-40^{\circ} \pm 1^{\circ}\text{C}$ ($-40^{\circ} \pm 2^{\circ}\text{F}$) and tested as specified in 4.5.8.

3.10 Fluid resistance at elevated temperature. Type I and type III sealing compound shall show no evidence of hardening, blistering, or any other deleterious property when tested as specified in 4.5.9. There is no heat resistance requirement for type II sealing compound.

3.11 Water vapor permeability. When tested as specified in 4.5.10, the water vapor permeability rate of the sealing compound shall not exceed the following requirements:

- Types I and III - Not greater than 0.010 gm/hr/sq. in.
- Type II - Not greater than 0.012 gm/hr/sq. in.

3.12 Color. The color shall be black (see 4.5.11).

3.13 Toxicity. The materials shall not contain any asbestos, mercury or chromate compounds. The material shall have no adverse effects on the health of personnel when used for its intended purpose. Questions pertinent to this effect shall be referred by the contracting activity to the appropriate

departmental medical service who will act as an advisor to the contracting agency (see 4.5.12).

3.14 Workmanship. The sealing compound shall be homogeneous and contain no foreign matter, and shall conform to the quality and grade of product established by this specification.

3.15 Material Safety Data Sheet (MSDS). A MSDS shall be prepared in accordance with FED-STD-313 (see 4.6).

4. QUALITY ASSURANCE PROVISIONS

4.1 Responsibility for inspection. Unless otherwise specified in the contract or purchase order, the contractor is responsible for the performance of all inspection requirements (examinations and tests) as specified herein. Except as otherwise specified in the contract or purchase order, the contractor may use his own or any other facilities suitable for the performance of the inspection requirements specified herein, unless disapproved by the Government. The Government reserves the right to perform any of the inspections set forth in this specification where such inspections are deemed necessary to ensure supplies and services conform to prescribed requirements.

4.2 Lot acceptance tests. A lot shall consist of all materials of the same type, from the same batch or blending operation, subjected to the same processing operations and conditions, produced by one manufacturer and offered for delivery at one time. Unless otherwise specified, for the purpose of lot acceptance tests, representative results shall be reported from the results obtained on a frequency basis for grades of sealing compound which are monitored using process control systems and procedures which insure no defects and shall be the basis for acceptance or rejection of the lot. Lot acceptance tests shall consist of the test indicated in table II.

TABLE II. Lot acceptance test requirements.

Characteristic	Requirements			Test Method
	Type I	Type II	Type III	
Volatile content	3.2	--	3.2	4.5.1
Water solubility	3.3	--	3.3	4.5.2
Oil Resistance	3.4	--	3.4	4.5.3
Adhesion	3.5	--	3.5	4.5.4
Aging	3.6	3.6	3.6	4.5.5
Effect of volatile compounds	3.7	--	3.7	4.5.6
Crazing	3.8	--	3.8	4.5.7
Low temperature flexibility	3.9	--	3.9	4.5.8
Fluid resistance	3.10	--	3.10	4.5.9
Water vapor permeability	3.11	3.11	3.11	4.5.10
Color	3.12	3.12	3.12	4.5.11
Toxicity	3.13	3.13	3.13	4.5.12

4.3. Sampling.

4.3.1 Sampling for examination of sealing compound. Unless otherwise specified a random sample of filled containers shall be selected in accordance with level 1 of MIL-STD-105.

4.3.2 Sampling for tests. A sample consisting on 1 qt (0.95 liter) of sealant or one roll of 50 ft (15 meter) tape, representative of the lot shall be selected and placed in a wide-mouth, glass, 1 qt (0.95 liter) container and sealed tightly.

4.4 Examination.

4.4.1 Examination of sealing compound. Sample units of sealing compound selected in accordance with 4.3.1 shall be examined for defects listed in table III. Sampling plan acceptance and rejection numbers apply collectively to all characteristics.

TABLE III. Classification of defects in sealing compound.

Classification of defect	Defect	Method of inspection
Major 101	Evidence of settling or separation (see 3.1)	Visual
Major 102	Milling and blending not as specified (see 3.1)	Visual
Major 103	Evidence of corrosion on inside of containers (see 3.1)	Visual
Major 104	Type III tape not on suitable release paper (see 3.1.3)	Manual and Visual
Major 105	Type III tape on improper cores or not wound properly (see 3.1.3)	Manual and Visual
Major 106	Type III tape of wrong dimensions (see 3.1.3)	Measure
Major 107	Evidence of foreign matter (see 3.14)	Visual
Major 108	Workmanship not as specified (see 3.14)	Visual

4.4.2 Cleaning on test panels. Except where otherwise specified herein, metal panels shall be cleaned with lint-free cheesecloth using solvent formulated in accordance with MIL-C-38736.

4.5 Tests.

4.5.1 Volatile content. Weigh a 2 by 4 inch (5.0 by 10.1 cm) aluminum panel to the nearest 0.001 g. Approximately 2 g of the sealing compound shall be spread uniformly to approximately 0.0625 in. (1.5 mm) thick on one side of the panel. The panel with the compound shall be weighed and then placed in an oven at $65.5^{\circ} \pm 1^{\circ}\text{C}$ ($150 \pm 2^{\circ}\text{F}$) for two hours. The panel with the compound shall then be reweighed. The loss in weight divided by the weight of the original coating multiplied by 100 shall constitute the percent of volatile content. Tests shall be performed in duplicate. Failure of either sample shall be cause for rejection of the lot (see 3.2).

4.5.2 Water solubility. The panels used in determining volatile content shall be immersed in distilled water and heated at $65.5^{\circ} \pm 1^{\circ}\text{C}$ ($150^{\circ} \pm$

20°F) for 4 hours. They shall then be removed and dried at $65.5^{\circ} \pm 1^{\circ}\text{C}$ ($150^{\circ} \pm 2^{\circ}\text{F}$) for 4 hours. The loss in weight divided by the weight of the coating after determination of the volatile content and multiplied by 100 shall constitute the percent of water soluble material. Failure of the sample shall be cause for rejection of the lot (see 3.3).

4.5.3 Oil resistance. Approximately 2 g of the sealing compound shall be spread uniformly on one side of a 1 by 4 in. (2.5 by 10.1 cm) aluminum panel. The aluminum shall have first been cleaned by dipping in MIL-C-38736 type I solvent for a few seconds, immersing in 3% alkaline cleaner (90% sodium metasilicate and 10% Aerosol OT-B) at 80°C (176°F) for 5 minutes, washing in running tap water, immersing in dichromate solution (85 grams of sodium dichromate, O-S-595, and 250 ml of concentrated sulfuric acid, O-S-809 type I, class I to 2 liters of distilled water) at 75°C (167°F) for 5 minutes, washing in running tap water and distilled water and drying. The sample shall then be partially immersed for 96 hours in oil conforming to Oil No. 2 (ASTM D471). The test shall be conducted at room temperature. The panel shall be removed and the sample examined for evidence of blistering, softening and lack of adhesion. Test shall be performed in duplicate. Failure of either sample shall be cause for rejection of the lot (see 3.4).

4.5.4 Adhesion. Test shall be made as described in ASTM D897 except that there shall be 3 types of specimens: (a) steel specimens as described in ASTM D897; (b) steel specimens with a thin glass wafer bonded with suitable adhesive (epoxy resin base) to the steel working surfaces; (c) steel specimen with a polyacrylic plastic (conforming to MIL-P-8184) wafer bonded to the working surface. The sealing compound shall be applied to both surfaces. The specimen shall be compressed under a load of 200 lb (90 kg) for about 20 seconds to insure a minimum gap between the adherents of the specimen. The prepared specimen shall be conditioned at room temperature $72^{\circ} - 77^{\circ}\text{F}$ ($22^{\circ} - 25^{\circ}\text{C}$) for 49 hours prior to testing. The bond strength of the assembly shall be measured in a tensile testing machine whose jaw separation speed is 1-in. per minute. The specimens shall be examined for failure in cohesion of the sealing material. Test shall be performed in duplicate. Failure of the sample shall be cause for rejection of the lot (see 3.5).

4.5.5 Aging. The consistency of the sealing compound shall be determined in the original condition and after aging for 24 hours at $65.5^{\circ} \pm 1^{\circ}\text{C}$ ($150^{\circ} \pm 2^{\circ}\text{F}$). The sample shall be tested in accordance with ASTM D217 tested for unworked penetration, using a 150 g total load for 5 seconds. Four readings shall be taken on each sample. More than one unsatisfactory reading shall be cause for rejection of the lot (see 3.6).

4.5.6 Effect of volatile components. A 5-6 g sample of the sealing compound shall be placed on a 2 in. (5.0 cm) diameter watch glass and then placed in an enclosed vessel which contains a polished polymethylmethacrylate (conforming to MIL-P-8184) window as shown on figure 1. The test fixture shall be placed in an oven at $71^{\circ} \pm 1^{\circ}\text{C}$ ($160^{\circ} \pm 2^{\circ}\text{F}$) for 3 hours, then removed and allowed to cool to a temperature of approximately 38°C (100°F). The outer surface of the polymethylmethacrylate window shall be cooled by placing a piece of dry ice having a flat size of about 0.5 in² onto the window of the fixture and allowing it to remain in contact with the window until condensation is observed on the inner surface of the window or for a period not greater than 20 minutes. The fixture shall then be

allowed to remain at room temperature for a period of 2 hours. The window of the fixture shall be removed and its inner surface washed with tap water and wiped with a soft cloth. The surface shall then be examined with the aid of a 10-power magnifier in the area where condensation had formed for visual evidence of crazing, pitting, or etching. Visual examination shall be done by viewing perpendicular to the surface and then at an angle of 30 to 45° to the surface. Tests shall be performed in duplicate. Failure of either sample shall be cause for rejection of the lot (see 3.7).

4.5.7 Crazing on stressed acrylic plastic. A piece of sheet plastic in accordance with MIL-P-8184 shall be set up as a cantilever beam under load, as shown in figure 2. After the beam has been loaded for 10 minutes and while still under load, the compound shall be applied to the top (tension) side of the plastic specimen two inches from the clamped end and directly above the support and allowed to remain an additional 10 minutes under load. The acrylic plastic sheet shall be examined with the aid of a 10 power magnifier for visual evidence of crazing or other attack while under stress. Visual examination shall be done by viewing perpendicular to the surface and then at an angle of 30 to 45° to the surface. Visible evidence of crazing or other attack while under stress constitutes failure of this test. Failure of the test shall be cause for rejection of the lot (see 3.8).

4.5.8 Low temperature flexibility. Two panels, 1 by 6 by 0.030 in. (2.5 by 15.2 by 0.07 cm) of aluminum surfaced aluminum alloy, conforming to QQ-A-250/5, shall be coated on one side with the sealing compound to a thickness of 0.03 in. (0.07 cm) or for the test of type III a single thickness of tape. The panels shall then be immersed for 48 hours at $38^{\circ} \pm 1^{\circ}\text{C}$ ($100^{\circ} \pm 2^{\circ}\text{F}$) in 30 percent aromatic hydrocarbon test fluid, conforming to TT-S-735, type III. At the completion of the immersion period, the panels and the flexibility jig (figure 3), shall be subjected to a temperature of $-40^{\circ} \pm 1^{\circ}\text{C}$ ($-40^{\circ} \pm 2^{\circ}\text{F}$) for two hours. While at this temperature, one end of the test panel shall be placed in the slotted position and the other bent around the curved portion of the flexibility test jig, at a steady uniform rate such that 3 seconds are required to complete the bend. The panels shall be removed and examined. Failure of either panel shall be cause for rejection of the lot (see 3.9).

4.5.9 Fluid resistance at elevated temperatures. Two panels, 3 by 5 inches (7.6 by 12.7 cm) of aluminum surfaced alloy conforming to QQ-A-250/5, shall be coated on one side with the sealing compound to a thickness of (0.0625 in. (0.16 cm) or for the test of type III a single thickness of the tape. The panels shall be immersed for 48 hours at $38^{\circ}\text{C} \pm 1^{\circ}\text{C}$ ($100^{\circ} \pm 2^{\circ}\text{F}$) in aromatic hydrocarbon test fluid conforming to TT-S-735, type III, so that one half of the material is above the liquid level. The panels shall then be removed, air dried for 24 hours, and baked at $82^{\circ} \pm 1^{\circ}\text{C}$ ($180^{\circ} \pm 2^{\circ}\text{F}$) for 72 hours. The panels shall then be examined for changes in film properties. Visible evidence of change in the film property shall constitute failure of this test. Failure of the sample shall be cause for rejection of the lot (see 3.10).

4.5.10 Water vapor permeability. A sufficient amount of sealing compound shall be pressed between two sheets of polyethylene film (0.003-0.004 inches thick), according to ASTM D4397 to form a film about 0.075 in. (0.19 cm) thick and 2 in. (5.0 cm) in diameter. One of the polyethylene sheets shall be

peeled off and a suitable size screen which shall retain the sealing compound shall be placed on the sealing compound. Use 2.5 inch (6.3 cm) diameter 30 mesh plain weave screening with 0.010 inch (0.025 m) diameter wire made of type 5056 aluminum or brass, according to ASTM E437. The polyethylene sheet shall be placed on the screen and the assembly shall be compressed until the overall thickness of the sealing compound and the screen is 0.064 ± 0.002 in. (0.16 ± 0.01 cm). The polyethylene sheets shall be removed and the screen-supported film shall be trimmed to size and placed in a position as shown in figure 4. 5 ml of distilled water shall be placed in a Petri dish. The two metal plates holding the film of sealing compound and the Petri dish shall be screwed tightly to insure a good seal between the edge of the Petri dish and the sealing material (see 3.11).

4.5.10.1 Assemblies. Two assemblies shall be prepared as described in 4.5.10. A third assembly shall be prepared in the same manner except that no water shall be placed in the Petri dish. The three assemblies shall be weighed to the nearest 0.001 grams and then placed in an oven at $71^{\circ} \pm 1^{\circ}\text{C}$ ($160^{\circ} \pm 2^{\circ}\text{F}$) for 4 hours. The loss in weight of the dry assembly shall be subtracted from the weight of each of the other two assemblies. The water vapor transmission rates shall be calculated in units of g of water/hr/in.² of open area. The open area is the area of the 1.875 in-hole in the metal plate minus the area occupied by the wires of the screen within the hole. Failure of either sample shall be cause for rejection of the lot. Percent of water vapor is calculated as follows:

$$\frac{\text{wt of (sample + water + dish)}}{\text{wt of dish}} \times 100$$

conducted at 1 hr intervals until constant weight.

4.5.11 Color. The material shall be visually examined for conformance to color requirements (see 3.12).

4.5.12 Toxicity. The supplier shall furnish the toxicological data and formulations required to evaluate the safety of the material for the proposed use (see 3.13).

4.5.13 Certification. The test procedures for type II for the quantity of grease and for the grease to be specified in MIL-G-23827 may be waived by the procuring activity upon certification by the supplier that the lot for acceptance meets the requirements of the specification. The certificate shall be signed by a responsible agent of the certifying organization and shall be accompanied by evidence of this agent's authority to bind his principal. The Government reserves the right to check test material submitted by the supplier under certification.

4.6 Inspection of Material Safety Data Sheet (MSDS). Material Safety Data Sheets shall be inspected to determine conformance to FED-STD-313 (see 3.15).

4.7 Inspection of packaging.

4.7.1 Quality conformance inspection of packaging.

4.7.1.1 Unit of product. For the purpose of inspection, a complete pack prepared for shipment shall be considered a unit of product.

4.7.1.2 Sampling. Sampling for examination shall be in accordance with MIL-STD-105.

4.7.2 Examination. Samples selected in accordance with 4.6.1.2 shall be examined for the following defects. Presence of one or more defects shall be cause for rejection (see table IV).

TABLE IV. Classification of defects, packaging requirements.

Classification of Defect	Defect	Method of Inspection
Major 109	Preservation not as specified for Level A or C	Visual
Major 110	Packing not as specified for Level A, B, or C	Visual
Major 111	Marking missing, illegible, incorrect or incomplete for Level A, B, or C	Visual

5. PACKAGING

5.1 Preservation. Preservation shall be level A or level C as specified (see 6.2).

5.1.1 Level A.

5.1.1.1 Preservation. Sealing compound shall be preserved level A as specified in MIL-STD-2073 (see 6.2).

5.1.2 Level C. For Army use only, preservation shall be accomplished in accordance with MIL-STD-1190.

5.2 Packing. Packing shall be level A, B or C, as specified (see 6.2).

5.2.1 Level A and B. Level A or B packing shall meet the requirements of MIL-STD-2073.

5.2.2 Level C packing for Army use. Level C shall be accomplished in accordance with MIL-STD-1190.

5.3 Marking. In addition to any special marking required by the contract (see 6.2), all unit intermediate and exterior shipping containers shall be marked in accordance with MIL-STD-129.

6. NOTES

(This section contains information of a general or explanatory nature that may be helpful, but is not mandatory.)

6.1 Intended use. The sealing compounds covered by this specification are intended for use in sealing metal to metal, glass to metal and acrylic to metal and for general purpose as deemed necessary by the using activity. This material is not to be used as an integral fuel tank or pressure cabin sealant.

6.2 Acquisition requirements. Procurement documents should specify the following:

- a. Title, number and date of the specification.
- b. Type of material required (see 1.2).
- c. Quantity of material desired.
- d. Level of preservation required (see 5.1)
- e. Level of packing required (see 5.2).
- e. Special marking if required (see 5.3)

6.3 Supersession. This specification supersedes MIL-S-11030E, dated 2 July 1976, type III of MIL-S-11030D had superseded type II (extruded tape) of MIL-S-7126A.

6.4 Subject term (Key word) Listing

Sealant Polysulfide

6.5 Changes from previous issue. Marginal notations are not used in this revision to identify changes with respect to the previous issue due to extensiveness of the changes.

Custodians:

Army - MR
Navy - AS
Air Force - 11

Preparing activity:

Army - MR

Project 8030-0488

Review activities:

Army - AT, ME, MD, MI, EA, AR, GL, SM
GSA - PSS
Air Force - 84, 99

User activity:

Navy - AS

(WP# ID 1682A/DISC 0029A. FOR MTL USE ONLY)

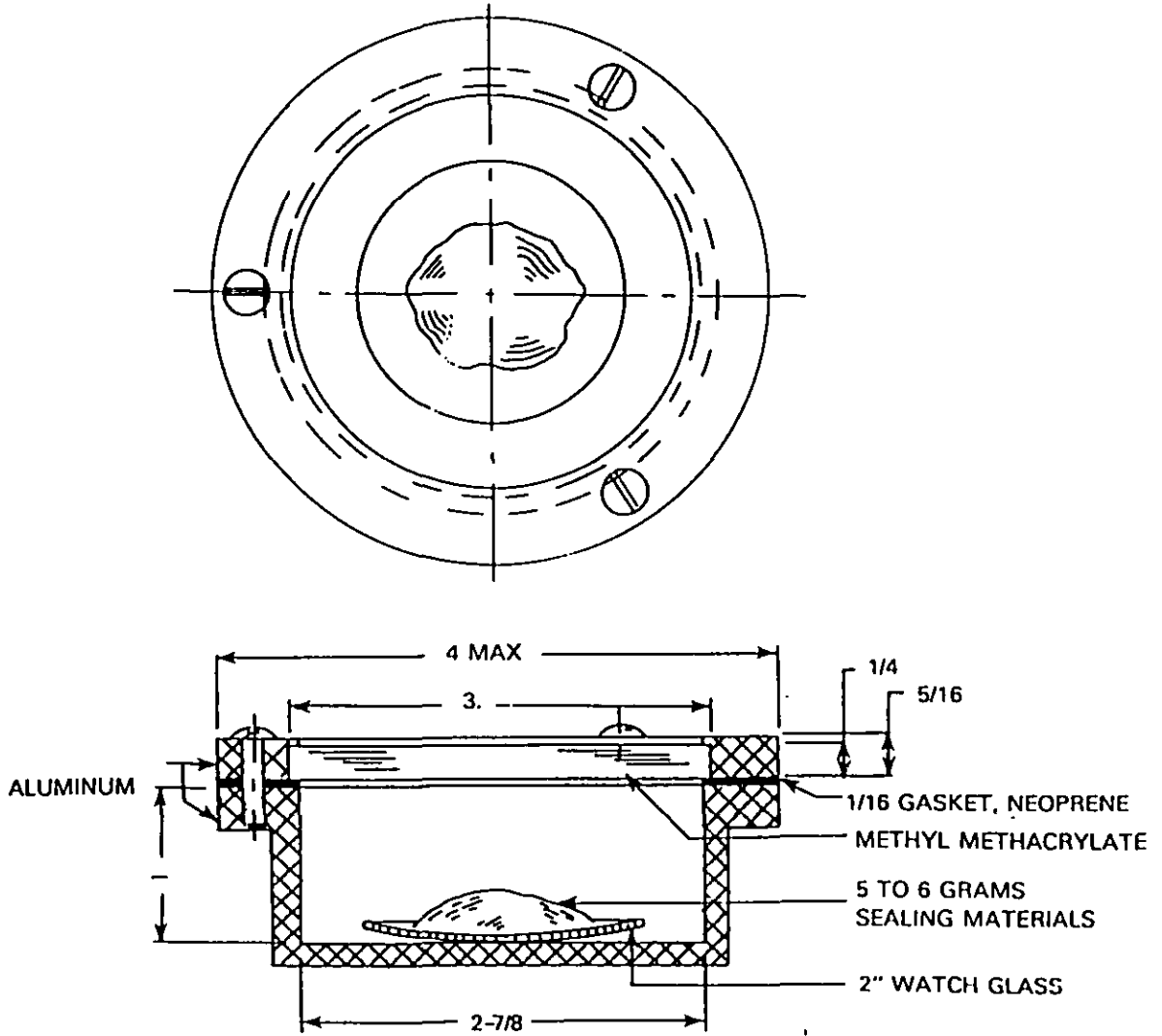
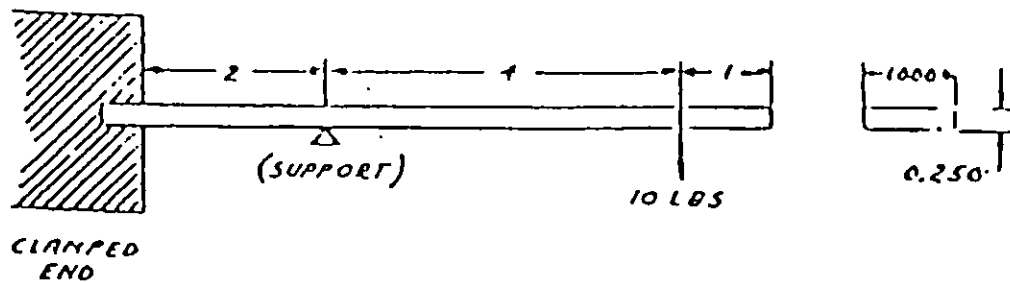
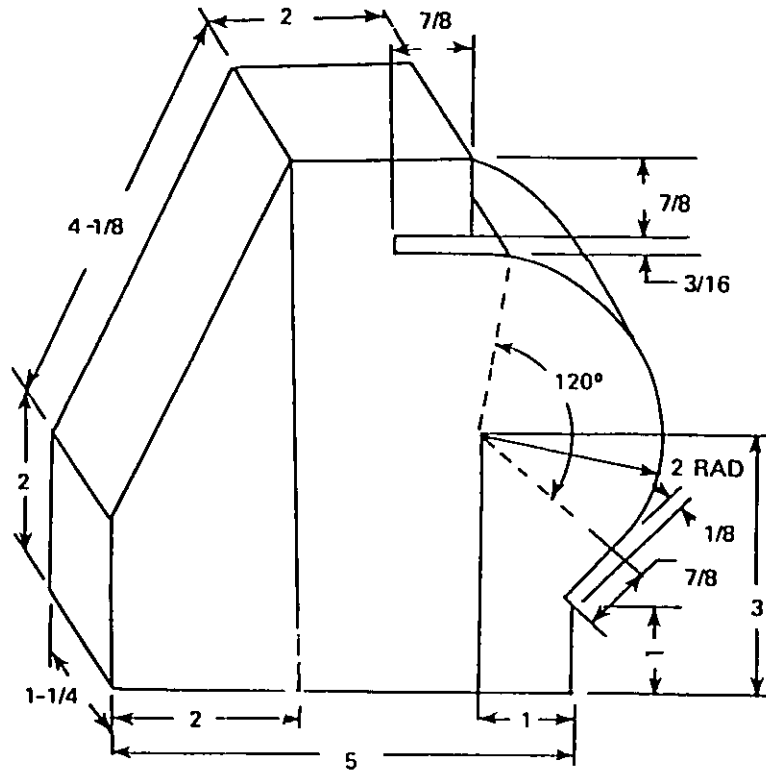

FIGURE 1. Assembly for test on effect of volatile components.
(dimensions in inches)



DIMENSIONS IN INCHES.

FIGURE 2. Stress crazing test.



MATERIAL: MAPLE WOOD

FIGURE 3. Low temperature flexibility test jig.
(dimensions in inches.)

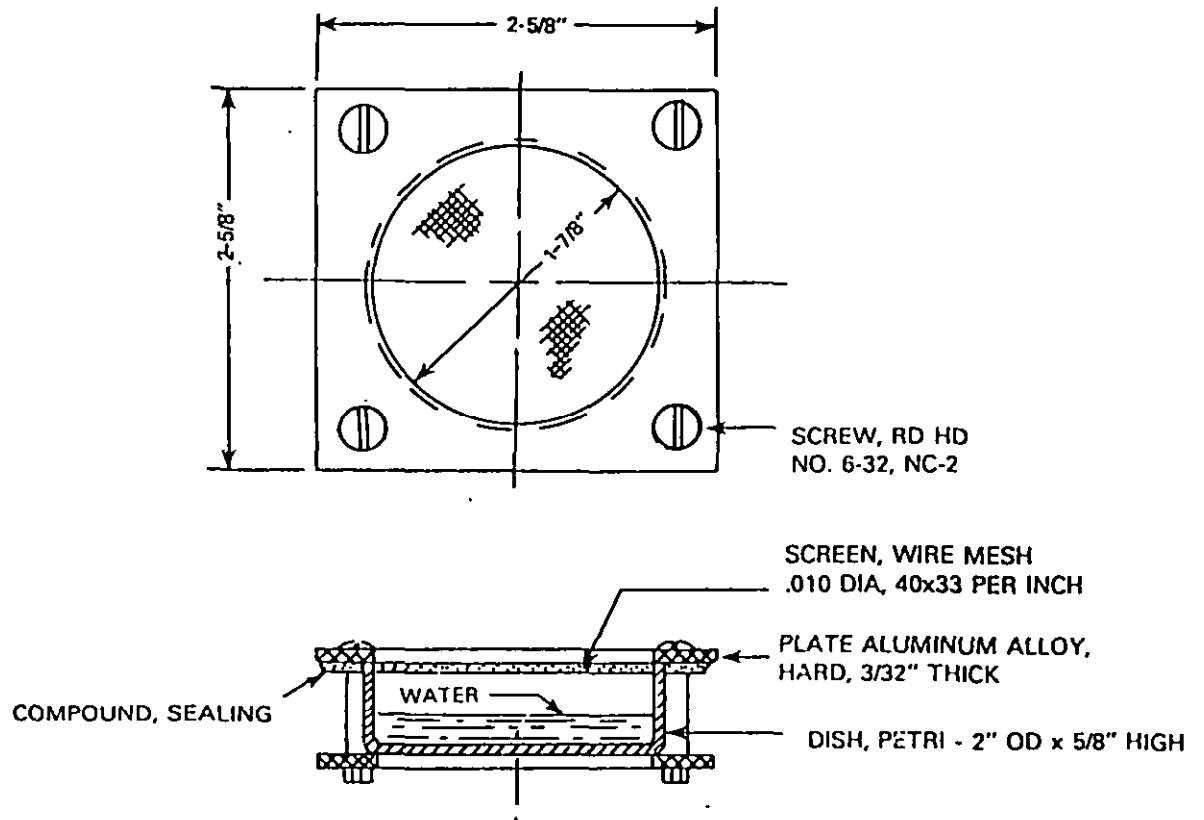

NOTE: TOP & BOTTOM PLATES ARE IDENTICAL, EXCEPT THAT
SCREW HOLES ARE TAPPED INTO BOTTOM PLATE

FIGURE 4. Assembly for water vapor permeability test.
(dimensions in inches)

