

The City of Muskogee encourages participation from all its citizens in public meetings. If participation is not possible due to a disability, notify the City Clerk, in writing, at least forty-eight hours prior to the scheduled meeting and necessary accommodations will be made (ADA 28 CFR/36).

**(Public Comment during Public Hearing or Agenda item comment)**

Council Rules of Decorum limit citizen comments on agenda items and public hearings to five (5) minutes and general comments for non-agenda items to (3) minutes. Any person desiring to address the Committee during such period is required to sign in with the City Clerk prior to the Committee meeting between 5:00 p.m. and 5:15 p.m. on the third floor of City Hall or any time between 8:00 a.m. and 5:00 p.m. in the Office of the City Clerk. They shall provide their name, address and specify the agenda item they wish to address. Remarks shall be directed to the matter being considered and the speaker is allowed to speak only one time. If written materials are to be submitted twelve (12) copies should be made available, and may not be returned.

**AGENDA**  
**FINANCE COMMITTEE**  
**APRIL 8, 2024**

*Official action can only be taken on items which appear on the agenda. The public body may adopt, approve, ratify, deny, defer, recommend, amend, strike, or continue any agenda item.*

*When more information is needed to act on an item, the public body may refer the matter to Staff or back to Committee or the recommending body.*

*Under certain circumstances, items are deferred to a specific date or stricken from the agenda entirely.*

**REGULAR SESSION - 5:30 P.M., 3RD FLOOR, COUNCIL CHAMBERS, MUNICIPAL BUILDING, 229 W. OKMULGEE, MUSKOGEE, OKLAHOMA**

INVOCATION - COMMITTEE MEMBER ALEX REYNOLDS

FLAG SALUTE - DEPUTY MAYOR DERRICK REED

1. Consider approval of Finance Committee minutes of March 11, 2024, or take other necessary action.
2. Consider approval of Resolution No. 2980 declaring items of personal property presently in the possession of the City of Muskogee, to be surplus to the needs of the City of Muskogee, and authorize the City Manager, or his designee, to offer for sale or dispose of the same, all as per the attached list, or take other necessary action. (Dennis Read)
3. Consider approval of Change Order No. 1 for US-62 and Country Club Signalization Project No. 2023004, with TLS Group, Inc., in the amount of \$22,715.32 for quantity overruns, or take other necessary action. (Mike Stewart)
4. Consider approval to purchase a 2023 Caterpillar 303.5 CR Mini Excavator for the Parks & Recreation Department in the amount of \$66,950.00, utilizing Sourcewell cooperative purchase pricing, or take other necessary action. (Mark Wilkerson)
5. Consider approval to apply for and accept the 2024 Attorney General's Safe Oklahoma Grant in the amount of \$17,600.00, or take other necessary action. (Johnny Teehee)

6. Discuss and take possible action related to a Forensic Audit of the City of Muskogee, or take other necessary action. (Councilor Traci McGee)

ADJOURN

**Finance Committee**

**1.**

Meeting Date: 04/08/2024  
Initiator: Jennifer Sharp, Admin II  
Department: City Clerk  
Staff Information Source:

---

Information

AGENDA ITEM TITLE:

Consider approval of Finance Committee minutes of March 11, 2024, or take other necessary action.

BACKGROUND:

RECOMMENDED ACTION:

---

Fiscal Impact

Attachments

3-11 finmin

---

## MINUTES

### OF THE FINANCE COMMITTEE OF THE CITY OF MUSKOGEE, OKLAHOMA MET IN REGULAR SESSION IN COUNCIL CHAMBERS OF CITY HALL MARCH 11, 2024

The Finance Committee of the City of Muskogee, Oklahoma, met in Regular Session at 5:30 p.m. on March 11, 2024, in Council Chambers, Municipal Building, 229 W. Okmulgee Ave., Muskogee, Oklahoma.

Present: Chair Derrick Reed; Vice Chair Jaime Stout; Committee Member Alex Reynolds; Committee Member Traci McGee; Committee Member Tracy Hoos; Committee Member Shirley Hilton-Flanary; Committee Member Perline Boyattia-Craig; Committee Memeber Patrick Cale

Absent: Mayor Marlon J. Coleman

Staff Present: Mike Miller, City Manager; Roger Kolman, Assistant City Manager; Katrina Bodenhamer, City Attorney; Tammy L. Tracy, City Clerk; Kenna Terrell, Deputy City Clerk; Mike Stewart, Public Works Director; Jeff Reeves, Project Manager; Dennis Read, Treasurer; Maggie Eaton, Human Resources Director; Jody Moore, Fire Chief; Avery Rigney, Assistant Public Works Director; Mark Wilkerson, Parks & Recreation Director; Seth Campbell, Assistant City Attorney; Alicia Glanz, Deputy Treasurer; Reggie Cotton, Deputy Police Chief; Austin Witt, Deputy City Attorney

Invocation was led by Deputy Mayor Derrick Reed.

Flag Salute was led by Deputy Mayor Derrick Reed.

1. Consider approval of Finance Committee minutes of February 12, 2024, or take other necessary action.

Motion was made by Committee Memeber Patrick Cale, seconded by Committee Member Alex Reynolds to approve of Finance Committee minutes of February 12, 2024.

AYE: Chair Derrick Reed, Vice Chair Jaime Stout, Committee Member Alex Reynolds, Committee Member Traci McGee, Committee Member Tracy Hoos, Committee Member Shirley Hilton-Flanary, Committee Member Perline Boyattia-Craig, Committee Memeber Patrick Cale

Carried - Unanimously

2. Consider approval of claims for all City departments February 3, 2024 through March 1, 2024, or take other necessary action.

Motion was made by Vice Chair Jaime Stout, seconded by Committee Member Patrick Cale to approve of claims for all City departments February 3, 2024 through March 1, 2024.

AYE: Chair Derrick Reed, Vice Chair Jaime Stout, Committee Member Alex Reynolds, Committee Member Traci McGee, Committee Member Tracy Hoos, Committee Member Shirley Hilton-Flanary, Committee Member Perline Boyattia-Craig, Committee Member Patrick Cale

Carried - Unanimously

3. Consider approval of the lowest and best bid from RJR Enterprises for the Langston Park Splashpad Project, for the base bid amount of \$272,715.50, with an Alternate A-1 Bid of \$18,315.00 for an additional shade structure, for a total of \$291,030.50, or take other necessary action. (Mark Wilkerson)

Motion was made by Committee Member Alex Reynolds, seconded by Committee Member Shirley Hilton-Flanary to approve of the lowest and best bid from RJR Enterprises for the Langston Park Splashpad Project, for the base bid amount of \$272,715.50, with an Alternate A-1 Bid of \$18,315.00 for an additional shade structure, for a total of \$291,030.50.

AYE: Chair Derrick Reed, Vice Chair Jaime Stout, Committee Member Alex Reynolds, Committee Member Traci McGee, Committee Member Tracy Hoos, Committee Member Shirley Hilton-Flanary, Committee Member Perline Boyattia-Craig, Committee Member Patrick Cale

Carried - Unanimously

4. Consider approval of an application for an Assistance to Firefighters Grant (AFG) for a Heavy Rescue Vehicle, and if awarded to receive said grant funds, and authorizing the use of the city's matching grant fund of \$85,000 for the required 10% match, or take other necessary action. (Jody Moore)

Motion was made by Vice Chair Jaime Stout, seconded by Committee Member Shirley Hilton-Flanary to approve of an application for an Assistance to Firefighters Grant (AFG) for a Heavy Rescue Vehicle, and if awarded to receive said grant funds, and authorizing the use of the city's matching grant fund of \$85,000 for the required 10% match.

AYE: Chair Derrick Reed, Vice Chair Jaime Stout, Committee Member Alex Reynolds, Committee Member Traci McGee, Committee Member Tracy Hoos, Committee Member Shirley Hilton-Flanary, Committee Member Perline Boyattia-Craig, Committee Member Patrick Cale

Carried - Unanimously

5. (Stricken) Consider directing staff to prepare a budget amendment transferring funds in the amount of \$455,000 from the city's hotel/motel tax fund to the Muskogee Tourism Authority to be restricted for capital expenditures or major projects. (Committee Member Patrick Cale)

There being no further business, the meeting was adjourned.

CHAIR DERRICK REED  
FINANCE COMMITTEE

finmin  
TT

**Finance Committee**

**2.**

Meeting Date: 04/08/2024  
Submitted For: Dennis Read, Finance  
Initiator: Benita Hotema, Assistant Financial Analyst  
Department: Finance  
Staff Information Source:

---

Information

AGENDA ITEM TITLE:

Consider approval of Resolution No. 2980 declaring items of personal property presently in the possession of the City of Muskogee, to be surplus to the needs of the City of Muskogee, and authorize the City Manager, or his designee, to offer for sale or dispose of the same, all as per the attached list, or take other necessary action. (Dennis Read)

BACKGROUND:

There are currently several items, per the attached list, that are no longer needed or cannot be used by the City of Muskogee. The City would like to dispose of these items of personal property as surplus.

RECOMMENDED ACTION:

Approve Resolution.

---

Fiscal Impact

Attachments

Resolution 2980 Surplus Property

---

**RESOLUTION NO. 2980**

**A RESOLUTION DECLARING CERTAIN ITEMS OF PERSONAL PROPERTY PRESENTLY IN THE POSSESSION OF THE CITY OF MUSKOGEE, TO BE SURPLUS TO THE NEEDS OF THE CITY OF MUSKOGEE AND AUTHORIZING THE CITY MANAGER TO OFFER FOR SELL OR DISPOSE OF THE SAME AS ATTACHED LIST.**

**WHEREAS**, the City of Muskogee, Oklahoma has in its possession certain items of personal property which can no longer be put to good use; and

**WHEREAS**, the City of Muskogee desires to dispose of items of personal property, which are no longer needed, as surplus properties, according to the provisions of the Charter and the Ordinances of the City;

**NOW, THEREFORE, BE IT RESOLVED BY THE CITY COUNCIL OF THE CITY OF MUSKOGEE, OKLAHOMA;**

**SECTION 1:** The property listed herein is hereby declared to be surplus to the needs of the City of Muskogee, Oklahoma.

<b><u>ITEM DESCRIPTION</u></b>	<b><u>QTY</u></b>	<b><u>WORKS?</u></b>	<b><u>SERIAL #</u></b>	<b><u>BRAND</u></b>	<b><u>MODEL</u></b>
<b><u>Civic Center</u></b>					
6x6 Steel Shelf	1	No			
Stainless Cart	1	No			
Office Chairs	5	No			
Magnifying Projector	1	Yes			
Commercial Warmer					
Box	1	Yes			
Projector Screen	1	No			
Commercial Floor					
Scrubber	1	No		Chariot	Iscrub
Commercial Floor					
Scrubber	1	No		Chariot	Z
Commercial					
Crockpots	3	No			
Residential Crockpots	4	Yes			
<b><u>Human Resource</u></b>					
Office Chairs	4	Yes			



**IT Dept**

Fax Machine	1	Unknown	U60995B4J124267	Brother	MFC-8220
Color Toner	5			Dell	5130cdn
Imaging Cartridge	3			Dell	5130cdn
Copier Toner	10			Xerox	Various Colors
Drum Cartridge	1			Xerox	VersaLink
Printer-Color	1	Unknown	7HB465505	Xerox	C400
DLP Front Projector	1	Unknown	3H6C1S1	Dell	S500wi
DLP Front Projector	1	Unknown	5C9SF22	Dell	S500wi
DLP Front Projector	1	Unknown	5D9SF22	Dell	S500wi
DLP Front Projector	1	Unknown	6D9SF22	Dell	S500wi
DLP Front Projector	1	Unknown	BC9SF22	Dell	S500wi
DLP Front Projector	1	Unknown	F66M1S1	Dell	S500wi
DLP Front Projector	1	Unknown	J69SF22	Dell	S500wi
Remote	1	Unknown	10024122	Dell	TSKB-IR02
DLP Front Projector	1	Unknown	20018919	Dell	TSKB-IR02
Remote	1	Unknown	30019057	Dell	TSKB-IR02
DLP Front Projector	1	Unknown	40005605	Dell	TSKB-IR02
Remote	1	Unknown	40005779	Dell	TSKB-IR02
DLP Front Projector	1	Unknown	40006539	Dell	TSKB-IR02
Remote	1	Unknown		Dell	TSKB-IR02
DLP Interactive Projector Pens (2) and Charging Station	1	Unknown		Dell	AirWrite II
DLP Interactive Projector Pens (2) and Charging Station	1	Unknown		Dell	AirWrite II
EZ-Bridge-LT Brackets&Accessories	1			Tycon Systems	
EZ-Bridge-LT Point-to-Point Bridge	1	Unknown	13020091	Tycon Systems	EZBR-0519
EZ-Bridge-LT Point-to-Point Bridge	1	Unknown	13020100	Tycon Systems	EZBR-0519
EZ-Bridge-LT Point-to-Point Bridge	1	Unknown	13130107	Tycon Systems	EZBR-0519
EZ-Bridge-LT Point-to-Point Bridge	1	Unknown	13130108	Tycon Systems	EZBR-0519
EZ-Bridge-LT Point-to-Point Bridge	1	Unknown	13130109	Tycon Systems	EZBR-0519
HD Digital Video Recorder&Mouse	1	Unknown	180630020		AD-5004CH
HotSpot	1	Unknown	09611333944	Sierra Wireless	AirCard 250U

HotSpot	1	Unknown	09612030575	Sierra Wireless	AirCard 250U
HotSpot	1	Unknown	09613319328	Sierra Wireless	
HotSpot	1	Unknown	09613379112	Sierra Wireless	
HotSpot	1	Unknown	089267098100066435	Netgear	AirCard 771S
HotSpot	1	Unknown	089890432401114422	Sierra Wireless	AirCard 803S
HotSpot	1	Unknown	QLI7046720	Franklin Wireless	FRKR910KIT
HotSpot Pocket WiFi	1	Unknown	320266883332	ZTE	ZTE MF975S
LIFEBOOK	1	No	Q1Z02166	Fujitsu	T731
LIFEBOOK	1	No	Q1Z02169	Fujitsu	T731
LIFEBOOK	1	No	Q1Z02178	Fujitsu	T731
LIFEBOOK	1	No	Q1Z02179	Fujitsu	T731
LIFEBOOK	1	No	Q1Z02181	Fujitsu	T731
LIFEBOOK	1	No	Q1Z02250	Fujitsu	T731
Monitor	1	No	CN-00KTG0-72872-15I-AD4M	Dell	E2210f
Monitor	1	No	CN-0D3073-74445-922-FDUL CN-0F4WW6-74261-4AA- 1PUU	Dell	1908FPt E2214Hb
Monitor	1	No	CN-0FP816-46633-76I-4W0L	Dell	1708FPb
Monitor	1	No	CN-0G433H-74445-97O- CWYL	Dell	2009Wt
Monitor	1	No	CN-0G433H-74445-97O-DS6L CN-0GFXN4-74445-2CC- C9LL	Dell	2009Wt P2312Ht
Monitor	1	No	CN-0MM226-73731-7B3-71RS	Dell	E198WFPv
Monitor	1	No	CN-0VXV49-72872-21G-J58L	Dell	E2311Hf
Monitor	1	No	8GLKY01TW-094TKJ-12800- 1936	Dell	P2010Ht Latitude PP01S
Laptop 12"Screen	1	No	1YK7GZ1	Dell	Optiplex 7010
PC-SmallFormFactor	1	No	1ZF3Z23	Dell	Optiplex 5070
PC-SmallFormFactor	1	No	1ZG0Z23	Dell	Optiplex 5070
PC-SmallFormFactor	1	No	1ZG2Z23	Dell	Optiplex 5070
PC-SmallFormFactor	1	No	2G9T282	Dell	Optiplex 7020
PC-SmallFormFactor	1	No	31GSDZ1	Dell	Optiplex 7010
PC-SmallFormFactor	1	No	42F60R1	Dell	Optiplex 790
PC-SmallFormFactor	1	No	42F70R1	Dell	Optiplex 790
PC-SmallFormFactor	1	No	46L0YM2	Dell	Optiplex 7050
PC-SmallFormFactor	1	No	46L2YM2	Dell	Optiplex 7050
PC-SmallFormFactor	1	No	4RP7GZ1	Dell	Optiplex 7010
PC-SmallFormFactor	1	No	6MMXTQ2	Dell	Optiplex 7050
PC-SmallFormFactor	1	No	6MNWTQ2	Dell	Optiplex 7050
PC-SmallFormFactor	1	No	6NSKRP2	Dell	Optiplex 7010
PC-SmallFormFactor	1	No	6SB0022	Dell	Optiplex 7010
PC-SmallFormFactor	1	No	6SBVZ12	Dell	Optiplex 7010

PC-SmallFormFactor	1	No	6SBZZ12	Dell	Optiplex 7010
PC-SmallFormFactor	1	No	6SCWZ12	Dell	Optiplex 7010
PC-SmallFormFactor	1	No	6SCXZ12	Dell	Optiplex 7010
PC-SmallFormFactor	1	No	6SD0022	Dell	Optiplex 7010
PC-SmallFormFactor	1	No	6SD1022	Dell	Optiplex 7010
PC-SmallFormFactor	1	No	7KCZBD1	Dell	Optiplex 745
PC-SmallFormFactor	1	No	8QPGQ22	Dell	Optiplex 7010
PC-SmallFormFactor	1	No	8QQ8Q22	Dell	Optiplex 7010
PC-SmallFormFactor	1	No	8QQBQ22	Dell	Optiplex 7010
PC-SmallFormFactor	1	No	8QQFQ22	Dell	Optiplex 7010
PC-SmallFormFactor	1	No	9119DV2	Dell	Optiplex 7060
PC-SmallFormFactor	1	No	BJTP052	Dell	Optiplex 7020
PC-SmallFormFactor	1	No	BTTP052	Dell	Optiplex 7020
PC-SmallFormFactor	1	No	CP3QXG2	Dell	Optiplex 7040
PC-SmallFormFactor	1	No	CP4PXG2	Dell	Optiplex 7040
PC-SmallFormFactor	1	No	H3TXN22	Dell	Optiplex 7010
PC-SmallFormFactor	1	No	HJG2FB2	Dell	Optiplex 7020
PC-SmallFormFactor	1	No	JD09842	Dell	Optiplex 7010
PC-SmallFormFactor	1	No	JKQR0T2	Dell	Optiplex 7060
PC-SmallFormFactor	1	No	JKQTOT2	Dell	Optiplex 7060
PC-SmallFormFactor	1	No	JKQW0T2	Dell	Optiplex 7060
PC-SmallFormFactor	1	No	JKRW0T2	Dell	Optiplex 7060
PC-SmallFormFactor	1	No	JKSK0T2	Dell	Optiplex 7060
VoiceSwitch					
ShoreGear SG-30	1	Unknown	S30F13102E8C5C	Shoretel	ST001
Wireless Microphone					
Diversity Receiver					SM58, T4N,
Charger	1	Unknown	0821000152	SHURE	PS20
Wireless Microphone					
Diversity Received					SM58, T4N,
Charger	1	Unknown	0821000154	SHURE	PS20
Large White Boards					
(4'x8')	2				
Medium White					
Boards (4'x6')	3				
<b><u>PW-Waterplant</u></b>					
Air Compressor 30					
gallon	1	Yes			
Towel Dispenser	6	Yes		Georgia Pacific	BlueUltra
Stir Plate	1	No		Fisher Scientific	
Fluoride Analyzer	1	Yes		Hach	CA610
TOC Analyzer	1	Unknown		Sievers	M5310
C12 Analyzer	1	Yes		Hach	CL17SC
Spectrophotometer	1	Unknown		Hach	DR2800
Spectrophotometer	1	No		Hach	DREL2800

Case				
Backup Battery	1	No	Ferrups	FE series
<b><u>Revenue</u></b>				
Office Chair	1	Yes		
Bill Counter Machine	1	Yes	Magner	MAGII 20TM
Red Adjustable Chair	1	Yes		
Black Adjust. Chair	1	Yes		
Chair Mats	2	Yes		

**SECTION 2:** The City of Muskogee authorizes the City Manager to sell or otherwise dispose of said real property and personal property listed above.

**PASSED AND APPROVED** by the City Council of the City of Muskogee, Oklahoma this \_\_\_\_\_ day of \_\_\_\_\_, 2024.

CITY OF MUSKOGEE,  
A municipal corporation,

\_\_\_\_\_  
MARLON J. COLEMAN, MAYOR

ATTEST

\_\_\_\_\_  
TAMMY L. TRACY, CITY CLERK

APPROVED as to form and legality this \_\_\_\_\_ day of \_\_\_\_\_, 2024.

\_\_\_\_\_  
KATRINA BODENHAMER, CITY ATTORNEY

**Finance Committee**

**3.**

**Meeting Date:** 04/08/2024

**Submitted For:** Mike Stewart, Public Works

**Initiator:** Ashley Wallace

**Department:** Public Works

**Staff Information Source:**

---

**Information**

**AGENDA ITEM TITLE:**

Consider approval of Change Order No. 1 for US-62 and Country Club Signalization Project No. 2023004, with TLS Group, Inc., in the amount of \$22,715.32 for quantity overruns, or take other necessary action. (Mike Stewart)

**BACKGROUND:**

The change order is related to bid line items that exceeded the engineers' estimates for roadway striping removal, and repairs to one (1) concrete pole base that was damaged by a motorist during the construction process.

**RECOMMENDED ACTION:**

Approve Change Order No.1 in the amount of \$22,715.32 to TLS Group, Inc.

---

**Fiscal Impact**

**Attachments**

Change Order No. 1

---



**TLS  
GROUP, INC**

P.O. Box 14788  
Oklahoma City, OK 73113  
(405) 524-1341

<b>To:</b> City Of Muskogee	<b>Contact:</b>
<b>Address:</b> 229 W Okmulgee Ave Muskogee, OK 74001	<b>Phone:</b>
	<b>Fax:</b>
<b>Project Name:</b> Change Order #01 - Quantity Overruns	<b>Bid Number:</b>
<b>Project Location:</b> US-62 & County Club Rd, Muskogee, OK	<b>Bid Date:</b> 3/4/2024

The following is a quotation for the above subject project.

Line #	Item Description	Estimated Quantity	Unit	Unit Price	Total Price
<b>Section 01 - Base Bid</b>					
01002	3" PVC SCH.40 PLASTIC CONDUIT TRENCHED	100.00	LF	\$50.00	\$5,000.00
01006	STRUCTURAL CONCRETE	7.98	CY	\$1,590.00	\$12,688.20
01007	REINFORCING STEEL	1,023.80	LB	\$2.40	\$2,457.12
01014	1/C NO.10 ELECT.COND.	90.00	LF	\$1.60	\$144.00
01021	5/C TRAFFIC SIGNAL ELECTRICAL CABLE	12.00	LF	\$4.00	\$48.00
01023	21/C TRAFFIC SIGNAL ELECTRICAL CABLE	114.00	LF	\$12.00	\$1,368.00
01025	E.P.S. OPTICAL DETECTOR CABLE	95.00	LF	\$4.30	\$408.50
01029	TRAFFIC STRIPE(MULTI-POLY.)(24" WIDE)	5.00	LF	\$21.00	\$105.00
01031	PAVEMENT MARKING REMOVAL(TRAFFIC STRIPE)	662.00	LF	\$0.75	\$496.50
<b>Total Price for above Section 01 - Base Bid Items:</b>					<b>\$22,715.32</b>

**Total Bid Price: \$22,715.32**

**Notes:**

- This change order represents overruns of base bid items to match field installed quantities.
- All notes from our original quote letter apply to this change order.

**Payment Terms:**

Terms for Payment are NET 30 days from date of our invoice.

<p><b>ACCEPTED:</b> The above prices, specifications and conditions are satisfactory and hereby accepted.</p> <p><b>Buyer:</b> _____</p> <p><b>Signature:</b> _____</p> <p><b>Date of Acceptance:</b> _____</p>	<p><b>CONFIRMED:</b> <b>TLS</b></p> <p><b>Authorized Signature:</b> _____</p> <p><b>Estimator:</b> Lawson Miracle 405-423-0623 estimating@tlsokc.com</p>
---	--

**Finance Committee**

4.

Meeting Date: 04/08/2024  
Submitted For: Mark Wilkerson, Parks & Recreation  
Initiator: Rick Ewing, Assistant Director Parks & Recreation  
Department: Parks & Recreation  
Staff Information Source: Mark Wilkerson

---

Information

AGENDA ITEM TITLE:

Consider approval to purchase a 2023 Caterpillar 303.5 CR Mini Excavator for the Parks & Recreation Department in the amount of \$66,950.00, utilizing Sourcewell cooperative purchase pricing, or take other necessary action. (Mark Wilkerson)

BACKGROUND:

In FY24, a new excavator was budgeted for the Parks & Recreation Department. The department would like to purchase a 2023 Caterpillar 303.5 CR Mini Excavator from Warren Cat in the amount of \$66,950.00, with all standard equipment in addition to the additional features of hydraulic quick coupler, thumb, 18" bucket, and angle blade for backfilling trenches and grading.

This unit is offered to the City of Muskogee under Sourcewell cooperative purchase pricing for a total discount of \$20,366.00 off the list price of \$85,536.00. The optional extended warranty of 84-MO/5000-HR at \$1,780.00 was included with the price. The purchase amount of \$66,950.00 is funded in account 213-7520-452.64-50.

RECOMMENDED ACTION:

Recommend approval to purchase the Caterpillar 303.5 CR Mini Excavator as quoted for the amount of \$66,950.

---

Fiscal Impact

FUNDING SOURCE:

This unit is offered to the City of Muskogee under Sourcewell cooperative purchase pricing for a total discount of \$20,366.00 off the list price of \$85,536.00. The optional extended warranty of 84-MO/5000-HR at \$1,780.00 was included with the price. The purchase amount of \$66,950.00 is funded in account 213-7520-452.64-50.

---

Attachments

Caterpillar 303.5 CR quote  
Caterpillar 303.5 CR specs

---



Quote 294022-01

Apr 01, 2024

CITY OF MUSKOGEE FLEET DEPARTMENT  
FLEET DEPARTMENT  
PO 1927  
MUSKOGEE  
Oklahoma  
74402

Attention: RICK EWING

Dear Rick Ewing, Thank you for this opportunity to quote Caterpillar products for your business needs. We are pleased to quote the following for your purchase consideration.

One (1) New Caterpillar Model: 303.5 Hydraulic Excavators with all standard equipment in addition to the additional specifications listed below:

**STOCK NUMBER:** C133016

**SERIAL NUMBER:** 0RE903793

**YEAR:** 2023

**SMU:** 5

We wish to thank you for the opportunity of quoting on your equipment needs. This quotation is valid for 30 days, after which time we reserve the right to re-quote. If there are any questions, please do not hesitate to contact me.

Sincerely,

Jeremy Mangrum  
Machine Sales Representative



**One (1) New Caterpillar Model: 303.5 Hydraulic Excavators with all standard equipment in addition to the additional specifications listed below:**

**STANDARD EQUIPMENT**

**POWERTRAIN** -Cat C1.7 NA engine -(U.S. EPA Tier 4 Final/ -JAPAN MLIT Tier 3) -Automatic engine idle -Automatic engine shutdown -Automatic two speed travel -Fuel water separator -

**UNDERCARRIAGE** -Track, 300 mm (11.8") -Dozer blade(BOCE) with float -Tie downs on track frame -

**HYDRAULICS** -Variable displacement piston pump -Smart tech electronic pump -Load sensing/flow sharing hydraulics -Automatic swing brake -Hydraulic lockout - all controls -One and two way auxiliary flow -Continuous auxiliary flow -Bio oil capable

**ELECTRICAL** -12 volt electrical system -Software (machine and monitor) -65 ampere alternator -650CCA maintenance free battery -Battery disconnect -Signaling/warning horn -12 volt power socket -

**OPERATOR ENVIRONMENT** -Product link PLE243 (regulations apply) -Cab sound pressure 94dB(A) ISO 6395 -Coat hook -Next generation color LCD monitor (IP66) --Fuel level and coolant temperature -gauges --Maintenance and machine monitoring --Performance and machine adjustments --Numeric security code --Multiple languages --Hour meter with wake up switch -Cup Holder -Utility space for mobile phone -ROPS - ISO 12117-2:2008 -TOPS - ISO 12117:1997 -Top guard ISO 10262: 1998 Level I -Adjustable wrist rests -Non suspension vinyl seat -Retractable high visibility seat belt -Removable washable floormat -Tilt operator station -Storage pocket -Skylight -Mounting bosses for front guard

**OTHER STANDARD EQUIPMENT** -Control Pattern Changer -Caterpillar corporate "one key" system -Door locks on cab door and external -enclosure doors -Lockable fuel cap -Beacon socket -Joystick travel and steering mode -Travel cruise control -Boom light -

**INSTRUCTIONS** -REGIONAL STANDARD EQUIPMENT INCLUDES: -United States and Canada --Accumulator, certified --Retractable high visibility -seat belt 75mm (3") --Ecology drain - engine --Auxiliary hydraulic lines --Auxiliary line quick disconnects -South America --Accumulator, certified --Retractable high visibility -seat belt 75mm (3") --Ecology drain - engine --Auxiliary hydraulic lines --Auxiliary line quick disconnects -

**MACHINE SPECIFICATIONS**

303.5 07A CR MHE CFG2B	616-3219
303.5 07A CR HYD EXCAVATOR	558-1751
SEAT, SUSPENSION, VINYL	519-9266
CAT KEY, WITH PASS CODE OPTION	525-4465
FILM, PRODUCT LINK, ANSI	541-4787
2 WAY CONTROL	542-1495
FILM, INC. CANADA	542-1504
BOOM LIGHT, LED	542-8886
HYDRAULIC OIL, STD	546-1520
SOFTWARE, PROPORTIONAL CONTROL	557-1709
SOFTWARE, STICK STEER CONTROL	557-1710
SOFTWARE, CODED START	557-1713
ALARM, TRAVEL	558-1744
BOOM, STANDARD	558-1754
LINES, BOOM W/O BLCV	558-1760
LINES, STICK W/O SLCV	558-1763
CANOPY, ROPS	563-6658
TRACK, 12", RUBBER	566-2914
BLADE, ANGLE, BOCE	568-5199
TRAVEL LEVERS AND PEDALS	568-5200
INSTRUCTIONS, ANSI	569-3572
LINKAGE, BUCKET, W/LIFTING EYE	571-9088
STICK, LONG, W/ THUMB BRACKET	571-9661
UNDERCARRIAGE, FIXED, ANGLE BLD	571-9665
DRAIN, ECOLOGY	573-4364
PRODUCT LINK, CELLULAR PL243	573-9677
LINES, BUCKET, LONG STICK	575-2776
CONTROL, 1ST AUX, JOYSTICK	575-4420
LINES, 1ST AUX, LONG STICK	575-7225
ENGINE, EPA TIER 4F	576-2961
MONITOR NEXT GEN, NO CAMERA	580-7179
ACCUMULATOR	588-2227
CWT EXTRA, 550LBS	592-1442
FILM, CANOPY	594-5727
FLOORMAT, CANOPY, W/TRAVEL	594-7895
SEAT BELT, 3" RETRACTABLE	599-7202
FILM, ROPS, ISO, CANOPY	602-3576
LANE 3 ORDER	0P-9003
SERIALIZED TECHNICAL MEDIA KIT	421-8926
SHIPPING/STORAGE PROTECTION	0P-2266
PACKING, LAST MILE PROGRAM	0P-4299
COUPLER, PG, HYDR.D.LOCK, 3-4T	485-5300
PINS, BUCKET, 40MM	154-2638
BUCKET-HD, 18", 2.9 FT3, 3T	464-9902
THUMB, HYDRAULIC, 3-4T	452-2740

CATERPILLAR LIST PRICE	\$85,536.00
<b>SOURCEWELL DISCOUNT OF 20% OFF LIST</b>	<b>(\$17,107.20)</b>
BALANCE BEFORE ADDITIONAL DEALER DISCOUNT	\$68,428.80
<b>ADDITIONAL DISCOUNT PROVIDED BY WARREN CAT</b>	<b>(\$3,258.80)</b>
BALANCE DUE BEFORE OPTIONAL EXTENDED WARRANTY	\$65,170.00
<i>OPTIONAL EXTENDED WARRANTY</i>	<i>\$1,780.00</i>
<b>BALANCE INCLUDING OPTIONAL EXTENDED WARRANTY</b>	<b>\$66,950.00</b>

**WARRANTY**

Standard Warranty:	Standard 24 Month 2000 Hour Full Machine Coverage
Extended Coverage:	303.5-84 MO/5000 HR PREMIER- <b>OPTIONAL FOR ADDITIONAL CHARGE</b>

**F.O.B/TERMS:**

Delivered to Muskogee, OK

**PAYMENT TERMS**

**Cash Invoice Terms**

CASH WITH ORDER	QUOTE SELL PRICE
\$0.00	\$66,950.00

Accepted by \_\_\_\_\_ on \_\_\_\_\_

Signature

# Cat<sup>®</sup> 303.5 CR

## MINI EXCAVATOR



### FEATURES:

The Cat<sup>®</sup> 303.5 CR Mini Excavator delivers power and performance in a compact size to help you work in a wide range of applications.

#### ALL DAY COMFORT

- Choose either a canopy or a sealed and pressurized cab which can be equipped with air conditioning, adjustable wrist rests, and a suspension seat option to help keep you working comfortably all day long.

#### EASY TO OPERATE

- Controls are easy to use and the intuitive Next Generation LCD monitor provides easy to read machine information. An advanced touchscreen monitor can also be equipped.

#### STICK STEER TRAVEL MODE

- Moving around the job site is even easier with the Cat Stick Steer option. Easily switch from traditional travel controls with levers and pedals to joystick controls to move the machine and to operate the blade. The benefit of less effort and improved control is in your hands!

#### BIG PERFORMANCE IN A COMPACT DESIGN

- Strong lift and dig performance helps you get the job done faster. The compact radius design lets you access and work in the tightest areas. Dozer float allows for easy clean up.

#### SAFETY ON THE JOB SITE

- Your safety is our top priority. The Cat mini excavator is designed to help keep you safe on the job. Courtesy work lights and a fluorescent retractable seat belt are just a couple of the safety features we've built into the machine.

#### SIMPLE SERVICE FOR LESS DOWNTIME

- Maintenance is quick and easy on the Cat mini excavator. Routine check points are easy to access at ground level through the side doors. The unique tilt up cab or canopy lets you reach additional service areas when needed.

#### LOWER OPERATING COSTS

- Equipped with features such as auto idle, auto engine shutdown, and efficient hydraulics with a variable displacement pump, the Cat mini excavator was designed with reducing your operating costs in mind.

#### UNMATCHED DEALER SUPPORT

- Your Cat dealer is here to help you reach your business goals. From providing equipment solutions to operator training to service needs and beyond, your Cat dealer is ready to help.

## Specifications

### Engine

Engine Model	C1.7	
<b>Net Power @ 2,200 rpm</b>		
ISO 9249, 80/1269/EEC	17.6 kW	23.6 hp
<b>Gross Power @ 2,200 rpm</b>		
SAE J1995:2014	18.4 kW	24.7 hp
Bore	84.0 mm	3.3 in
Stroke	100.0 mm	3.9 in
Displacement	1.7 L	104.0 in <sup>3</sup>

- Meets U.S. EPA Tier 4 Final and EU Stage V emission standards.
- Net power advertised is the power available at the flywheel when the engine is at rated speed and rated power when the engine is installed with the factory configured fan, air intake system, exhaust system, and alternator with a minimum alternator load.

### Weights

Minimum Operating Weight with Canopy*	3480 kg	7,673 lb
Maximum Operating Weight with Canopy**	4050 kg	8,930 lb
Minimum Operating Weight with Cab*	3620 kg	7,982 lb
Maximum Operating Weight with Cab**	4190 kg	9,239 lb
EU: CE Plate Weight with Canopy***	3530 kg	7,784 lb
EU: CE Plate Weight with Cab***	3630 kg	8,004 lb

\*Minimum Weight is based on fixed rubber tracks, operator, full fuel tank, standard stick, blade, bucket and no extra counterweight.

\*\*Maximum Weight is based on steel tracks, operator, full fuel tank, long stick, blade, bucket and extra counterweight.

\*\*\*CE Plate Weight is based on the most common EU configuration. Includes 75 kg (165 lb) operator and full fuel tank and excludes bucket.



# 303.5 CR Mini Excavator

## Weight Increase from Minimum Configuration

Cab	140 kg	309 lb
Counterweight (light)	100 kg	221 lb
Counterweight (extra)	250 kg	551 lb
Long Stick	20 kg	44 lb
Steel Tracks	130 kg	287 lb
Angle Blade	160 kg	353 lb

## Travel System

Travel Speed – High	4.5 km/h	2.8 mph
Travel Speed – Low	2.6 km/h	1.6 mph
Maximum Traction Force – High Speed	16.9 kN	3,799 lbf
Maximum Traction Force – Low Speed	31.0 kN	6,969 lbf
Ground Pressure – Minimum Weight	29.6 kPa	4.3 psi
Ground Pressure – Maximum Weight	35.7 kPa	5.2 psi
Gradeability (maximum)	30 degrees	

## Service Refill Capacities

Cooling System	7.0 L	1.8 gal
Engine Oil	6.0 L	1.6 gal
Fuel Tank	45.0 L	11.9 gal
Hydraulic Tank	20.0 L	5.3 gal
Hydraulic System	45.0 L	11.9 gal

## Hydraulic System

Load Sensing Hydraulics with Variable Displacement Piston Pump

Pump Flow @ 2,400 rpm	100 L/min	26 gal/min
Operating Pressure – Equipment	245 bar	3,553 psi
Operating Pressure – Travel	245 bar	3,553 psi
Operating Pressure – Swing	181 bar	2,625 psi
Auxiliary Circuit – Primary		
Flow*	70 L/min	18 gal/min
Pressure*	245 bar	3,553 psi
Auxiliary Circuit – Secondary		
Flow*	25 L/min	7.0 gal/min
Pressure*	245 bar	3,553 psi
Digging Force – Stick (standard)	18.9 kN	4,249 lbf
Digging Force – Stick (long)	16.9 kN	3,799 lbf
Digging Force – Bucket	33.0 kN	7,419 lbf

\*Flow and pressure are not combinable. Under load, as flow rises pressure goes down.

## Swing System

Machine Swing Speed	9.0 rpm
Boom Swing – Left	75 Degrees
Boom Swing – Right	50 Degrees

## Blade

Width	1780 mm	70.1 in
Height	350 mm	13.8 in

## Certification – Cab and Canopy

Roll Over Protective Structure (ROPS)	ISO 12117-2:2008
Tip Over Protective Structure (TOPS)	ISO 12117:1997
Top Guard	ISO 10262:1998 (Level I)

## Sound

Operator Sound Pressure (ISO 6396:2008)	78 dB(A)
Average Exterior Sound Pressure (ISO 6395:2008)	94 dB(A)

• European Union Directive “2000/14/EC”

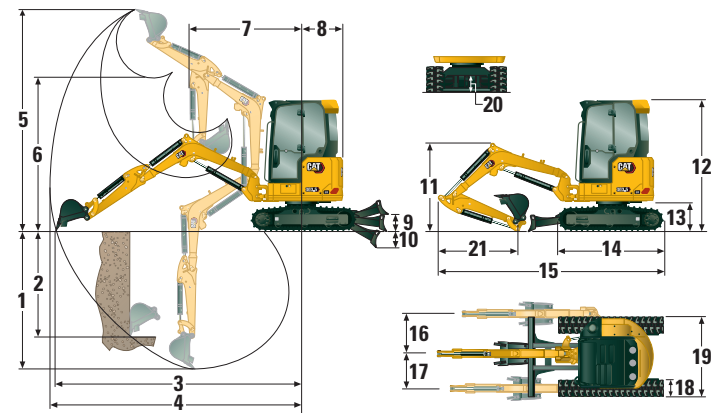

## Dimensions

	Standard Stick	Long Stick
<b>1</b> Dig Depth	2810 mm (110.6 in)	3110 mm (122.4 in)
<b>2</b> Vertical Wall	2250 mm (88.6 in)	2390 mm (94.1 in)
<b>3</b> Maximum Reach at Ground Level	5130 mm (202.0 in)	5380 mm (211.8 in)
<b>4</b> Maximum Reach	5270 mm (207.5 in)	5510 mm (216.9 in)
<b>5</b> Maximum Dig Height	4920 mm (193.7 in)	5020 mm (197.6 in)
<b>6</b> Maximum Dump Clearance	3490 mm (137.4 in)	3600 mm (141.7 in)
<b>7</b> Boom in Reach	1760 mm (69.3 in)	1860 mm (73.2 in)
<b>8</b> Tail Swing		
without Counterweight	890 mm (35.0 in)	890 mm (35.0 in)
with Counterweight (light)	960 mm (37.8 in)	960 mm (37.8 in)
with Counterweight (extra)	1005 mm (39.6 in)	1005 mm (39.6 in)
<b>9</b> Maximum Blade Height	385 mm (15.2 in)	385 mm (15.2 in)
<b>10</b> Maximum Blade Depth	535 mm (21.1 in)	535 mm (21.1 in)
<b>11</b> Boom Height in Shipping Position	1520 mm (59.8 in)	1750 mm (68.9 in)
<b>12</b> Overall Shipping Height	2480 mm (97.6 in)	2480 mm (97.6 in)
<b>13</b> Swing Bearing Height	565 mm (22.2 in)	565 mm (22.2 in)
<b>14</b> Overall Undercarriage Length	2220 mm (87.4 in)	2220 mm (87.4 in)
<b>15</b> Overall Shipping Length†	4800 mm (189.0 in)	4850 mm (190.9 in)
<b>16</b> Boom Swing Right	870 mm (34.3 in)	870 mm (34.3 in)
<b>17</b> Boom Swing Left	640 mm (25.2 in)	640 mm (25.2 in)
<b>18</b> Track Belt/Shoe Width	300 mm (11.8 in)	300 mm (11.8 in)
<b>19</b> Track Width	1780 mm (70.1 in)	1780 mm (70.1 in)
<b>20</b> Ground Clearance	310 mm (12.2 in)	310 mm (12.2 in)
<b>21</b> Stick Length	1260 mm (49.6 in)	1560 mm (61.4 in)

†Overall Shipping Length depends on blade position during shipment.

## Cab

Lift Capacities – Minimum Configuration			Lift Point Radius – 2 m (6.6 ft)			Lift Point Radius – 3 m (9.8 ft)			Lift Point Radius (Maximum)					
			Over Front			Over Side	Over Front			Over Side	Over Front		Over Side	m (ft)
			Blade Down	Blade Up	kg (lb)		Blade Down	Blade Up	kg (lb)		Blade Down	Blade Up		
3 m (9.8 ft)	Standard Stick	kg (lb)				*917 (*2,022)	*917 (*2,022)	904 (1,993)	*835 (*1,841)	583 (1,285)	575 (1,268)	3.95 (13.0)		
	Long Stick	kg (lb)							*758 (*1,671)	514 (1,133)	507 (1,118)	4.26 (14.0)		
2 m (6.6 ft)	Standard Stick	kg (lb)				*1176 (*2,593)	888 (1,958)	867 (1,911)	*809 (*1,784)	483 (1,065)	478 (1,054)	4.41 (14.5)		
	Long Stick	kg (lb)				*1033 (*2,377)	892 (1,967)	870 (1,918)	*750 (*1,653)	435 (959)	430 (948)	4.67 (15.3)		
1 m (3.3 ft)	Standard Stick	kg (lb)				*1547 (*3,411)	833 (1,836)	813 (1,792)	*860 (*1,896)	454 (1,001)	449 (990)	4.54 (14.9)		
	Long Stick	kg (lb)				*1462 (*3,223)	831 (1,832)	811 (1,788)	*805 (*1,775)	410 (904)	406 (895)	4.79 (15.7)		
0 m (0 ft)	Standard Stick	kg (lb)				*1676 (*3,695)	805 (1,775)	786 (1,733)	*947 (*2,088)	472 (1,041)	466 (1,027)	4.39 (14.4)		
	Long Stick	kg (lb)	*1345 (*2,965)	*1345 (*2,965)	*1345 (*2,965)	*1696 (*3,739)	793 (1,748)	774 (1,706)	*907 (*2,000)	424 (935)	420 (926)	4.63 (15.2)		

Minimum Weight includes cab, rubber tracks, no extra counterweight, operator, full fuel tank and blade.

Lift Capacities – Maximum Configuration			Lift Point Radius – 2 m (6.6 ft)			Lift Point Radius – 3 m (9.8 ft)			Lift Point Radius (Maximum)					
			Over Front			Over Side	Over Front			Over Side	Over Front		Over Side	m (ft)
			Blade Down	Blade Up	kg (lb)		Blade Down	Blade Up	kg (lb)		Blade Down	Blade Up		
3 m (9.8 ft)	Standard Stick	kg (lb)				*917 (*2,022)	*917 (*2,022)	*917 (*2,022)	*835 (*1,841)	720 (1,587)	663 (1,462)	3.95 (13.0)		
	Long Stick	kg (lb)							*758 (*1,671)	638 (1,407)	588 (1,296)	4.26 (14.0)		
2 m (6.6 ft)	Standard Stick	kg (lb)				*1176 (*2,593)	1086 (2,394)	988 (2,178)	*809 (*1,784)	602 (1,327)	556 (1,226)	4.41 (14.5)		
	Long Stick	kg (lb)				*1033 (*2,377)	*1033 (*2,377)	992 (2,187)	*750 (*1,653)	546 (1,204)	504 (1,111)	4.67 (15.3)		
1 m (3.3 ft)	Standard Stick	kg (lb)				*1547 (*3,411)	1031 (2,273)	936 (2,064)	*860 (*1,896)	568 (1,252)	524 (1,155)	4.54 (14.9)		
	Long Stick	kg (lb)				*1462 (*3,223)	1029 (2,269)	933 (2,057)	*805 (*1,775)	518 (1,142)	477 (1,052)	4.79 (15.7)		
0 m (0 ft)	Standard Stick	kg (lb)				*1676 (*3,695)	1003 (2,211)	909 (2,004)	*947 (*2,088)	591 (1,303)	545 (1,202)	4.39 (14.4)		
	Long Stick	kg (lb)	*1345 (*2,965)	*1345 (*2,965)	*1345 (*2,965)	*1696 (*3,739)	991 (2,185)	897 (1,978)	*907 (*2,000)	536 (1,182)	494 (1,089)	4.63 (15.2)		

Maximum Weight includes cab, steel tracks, extra counterweight, operator, full fuel tank and blade.

## Canopy

Lift Capacities – Minimum Configuration			Lift Point Radius – 2 m (6.6 ft)			Lift Point Radius – 3 m (9.8 ft)			Lift Point Radius (Maximum)					
			Over Front			Over Side	Over Front			Over Side	Over Front		Over Side	m (ft)
			Blade Down	Blade Up	kg (lb)		Blade Down	Blade Up	kg (lb)		Blade Down	Blade Up		
3 m (9.8 ft)	Standard Stick	kg (lb)				*917 (*2,022)	884 (1,949)	866 (1,909)	*835 (*1,841)	555 (1,224)	549 (1,210)	3.95 (13.0)		
	Long Stick	kg (lb)							*764 (*1,684)	490 (1,080)	485 (1,069)	4.26 (14.0)		
2 m (6.6 ft)	Standard Stick	kg (lb)				*1176 (*2,593)	846 (1,865)	829 (1,828)	*809 (*1,784)	458 (1,010)	455 (1,003)	4.41 (14.5)		
	Long Stick	kg (lb)				*1034 (*2,280)	851 (1,876)	834 (1,839)	*755 (*1,664)	413 (911)	411 (906)	4.67 (15.3)		
1 m (3.3 ft)	Standard Stick	kg (lb)				*1547 (*3,411)	791 (1,744)	776 (1,711)	*860 (*1,896)	429 (946)	427 (941)	4.54 (14.9)		
	Long Stick	kg (lb)				*1461 (*3,221)	788 (1,737)	772 (1,702)	*809 (*1,784)	389 (858)	387 (853)	4.79 (15.7)		
0 m (0 ft)	Standard Stick	kg (lb)				*1676 (*3,695)	763 (1,682)	749 (1,651)	*947 (*2,088)	446 (983)	443 (977)	4.39 (14.4)		
	Long Stick	kg (lb)	*1351 (*2,978)	*1351 (*2,978)	*1351 (*2,978)	*1694 (*3,735)	749 (1,651)	735 (1,620)	*908 (*2,002)	402 (886)	399 (880)	4.63 (15.2)		

Minimum Weight includes canopy, rubber tracks, no extra counterweight, operator, full fuel tank and blade.

Lift Capacities – Maximum Configuration			Lift Point Radius – 2 m (6.6 ft)			Lift Point Radius – 3 m (9.8 ft)			Lift Point Radius (Maximum)					
			Over Front			Over Side	Over Front			Over Side	Over Front		Over Side	m (ft)
			Blade Down	Blade Up	kg (lb)		Blade Down	Blade Up	kg (lb)		Blade Down	Blade Up		
3 m (9.8 ft)	Standard Stick	kg (lb)				*917 (*2,022)	*917 (*2,022)	*917 (*2,022)	*835 (*1,841)	691 (1,523)	639 (1,409)	3.95 (13.0)		
	Long Stick	kg (lb)							*758 (*1,671)	612 (1,349)	566 (1,248)	4.26 (14.0)		
2 m (6.6 ft)	Standard Stick	kg (lb)				*1176 (*2,593)	1044 (2,302)	953 (2,101)	*809 (*1,784)	577 (1,272)	534 (1,177)	4.41 (14.5)		
	Long Stick	kg (lb)				*1033 (*2,277)	*1033 (*2,277)	956 (2,108)	*750 (*1,653)	523 (1,153)	483 (1,065)	4.67 (15.3)		
1 m (3.3 ft)	Standard Stick	kg (lb)				*1547 (*3,411)	989 (2,180)	901 (1,986)	*860 (*1,896)	544 (1,199)	504 (1,111)	4.54 (14.9)		
	Long Stick	kg (lb)				*1462 (*3,223)	987 (2,176)	898 (1,980)	*805 (*1,775)	495 (1,091)	458 (1,010)	4.79 (15.7)		
0 m (0 ft)	Standard Stick	kg (lb)				*1676 (*3,695)	961 (2,199)	874 (1,927)	*947 (*2,088)	566 (1,248)	523 (1,153)	4.39 (14.4)		
	Long Stick	kg (lb)	*1345 (*2,965)	*1345 (*2,965)	*1345 (*2,965)	*1696 (*3,739)	949 (2,092)	862 (1,900)	*907 (*2,000)	513 (1,131)	473 (1,043)	4.63 (15.2)		

Maximum Weight includes canopy, steel tracks, extra counterweight, operator, full fuel tank and blade.

\*The above loads are in compliance with hydraulic excavator lift capacity rating standard ISO 10567:2007 and they do not exceed 87% of hydraulic lifting capacity or 75% of tipping capacity. The excavator bucket weight is not included on this chart. Lifting capacities are for standard stick.

# 303.5 CR Mini Excavator

## Standard and Optional Equipment

Standard and optional equipment may vary. Consult your Cat dealer for details.

	Standard	Optional		Standard	Optional
<b>ENGINE</b>			<b>OPERATOR ENVIRONMENT (continued)</b>		
Cat® C1.7 NA Engine (U.S. EPA Tier 4 Final/EU Stage V)	✓		Next Generation Color LCD Monitor (IP66)	✓	
Automatic Engine Idle	✓		– Fuel Level and Coolant Temperature Gauges	✓	
Automatic Engine Shutdown	✓		– Maintenance and Machine Monitoring	✓	
Automatic Two Speed Travel	✓		– Performance and Machine Adjustments	✓	
Fuel Water Separator	✓		– Numeric Security Code	✓	
Power on Demand (not available in all regions)	✓		– Multiple Languages	✓	
Variable Displacement Piston Pump	✓		– Hour Meter with Wake Up Switch	✓	
Load Sensing/Flow Sharing Hydraulics	✓		– Jog Dial (cab only)	✓	
<b>HYDRAULICS</b>			Next Generation Advanced Monitor		✓
Smart Tech Electronic Pump	✓		– Touch Screen		✓
Accumulator	✓		– Site Reference System		✓
Automatic Swing Brake	✓		– High Definition Camera Capable (IP68 and IP69K)		✓
Auxiliary Hydraulic Lines	✓		– Numeric Security Code		✓
One and Two Way Auxiliary Flow	✓		<b>UNDERCARRIAGE</b>		
Continuous Auxiliary Flow	✓		Rubber Belt (300 mm/11.8 in wide)	✓	
Auxiliary Line Quick Disconnects	✓		Steel Track (300 mm/11.8 in wide)		✓
<b>OPERATOR ENVIRONMENT</b>			Dozer Blade	✓	
Tilt-up Canopy or Tilt-Up Cab	✓		Dozer Blade Float	✓	
Cab with Air Conditioning		✓	Angle Blade		✓
Cab with Heater		✓	Tie Downs on Track Frame	✓	
Top Guard ISO 10262:1998 Level I	✓		<b>BOOM, STICK AND LINKAGES</b>		
ROPS – ISO 12117-2:2008	✓		One Piece Boom (2400 mm/94.5 in)	✓	
TOPS – ISO 12117:1997	✓		Standard Stick (1260 mm/49.6 in)	✓	
Stick Steer Mode	✓		Long Stick (1560 mm/61.4 in)		✓
Travel Cruise Control	✓		Front Shovel Capable	✓	
Control Pattern Changer (optional in some regions)	✓		Pin-On	✓	
Adjustable Wrist Rests	✓		Dual Lock Manual Coupler		✓
Washable Floor Mat	✓		Hydraulic Coupler		✓
Travel Pedals and Hand Levers	✓		Thumb Ready (not available in all regions)	✓	
No Travel Pedals and Hand Levers (optional in some regions)		✓	Certified Lifting Eye (optional in some regions)	✓	
Machine Security	✓		Attachments including Couplers, Thumbs, Buckets, Augers and Hammers		✓
Standard Key with Pass Code	✓		2nd Auxiliary Hydraulic Lines		✓
Push to Start with Key Fob/Pass Code		✓	Bucket Divert Lines		✓
Fabric Suspension Seat (Cab only)	✓		Boom Lowering Check Valve		✓
Vinyl Suspension Seat (Canopy only)	✓		Stick Lowering Check Valve		✓
Vinyl Non-Suspension Seat (Canopy only) (not available in all regions)		✓	Hydraulic Quick Coupler Lines (not available in all regions)		✓
Hydraulic Lockout – All Controls	✓		<b>ELECTRICAL</b>		
Retractable High Visibility Seat Belt (75 mm/3 in)	✓		12 Volt Battery	✓	
Coat Hook	✓		Software (machine and monitor)	✓	
Cup Holder	✓		Maintenance Free Battery	✓	
Storage Pocket	✓		Battery Disconnect	✓	
Skylight	✓		Signaling/Warning Horn	✓	
Mounting Bosses for Front	✓		12 Volt Power Socket	✓	
Signaling/Warning Horn	✓		Product Link PL243 (regulations apply)		✓
Interior Light (Cab only)	✓		Product Link PLE643 (regulations apply)		✓
Boom Light, Halogen (not available in all regions)	✓		Travel Alarm (standard in some regions)		✓
LED Front Lights		✓	<b>GUARDING</b>		
LED Front and Rear Lights		✓	Polycarbonate Half Height Front Guard (Canopy only)		✓
LED Boom Light		✓	Polycarbonate Front Guard (ISO 10262:1998 Level I and EN356 P5A)		✓
Utility Space for Mobile Phone	✓		Heavy Duty Front Guard ISO 10262:1998 Level II		✓
Mirrors Left and Right		✓	<b>OTHER</b>		
Camera		✓	Bio Oil Capable		✓
Radio – Bluetooth®, Auxiliary, Microphone, USB (charging only) (Cab only)		✓	Eco Drain		✓
			Water Jacket Heater		✓
			Light Counterweight (100 kg/221 lb)		✓
			Extra Counterweight (250 kg/551 lb)		✓

For more complete information on Cat products, dealer services, and industry solutions, visit us on the web at [www.cat.com](http://www.cat.com)

© 2021 Caterpillar  
All rights reserved

Materials and specifications are subject to change without notice. Featured machines in photos may include additional equipment. See your Cat dealer for available options.

CAT, CATERPILLAR, LET'S DO THE WORK, their respective logos, "Caterpillar Corporate Yellow," the "Power Edge" and Cat "Modern Hex" trade dress as well as corporate and product identity used herein, are trademarks of Caterpillar and may not be used without permission.

AEHQ8351-00 (03-2021)  
Build Number: 07A  
(Global excluding  
China and Japan)



**Finance Committee**

**5.**

Meeting Date: 04/08/2024

Submitted For: Johnny Teehee, Police

Initiator: Gayle Johnson, Chief Secretary

Department: Police

Staff Information Source:

Information

AGENDA ITEM TITLE:

Consider approval to apply for and accept the 2024 Attorney General's Safe Oklahoma Grant in the amount of \$17,600.00, or take other necessary action. (Johnny Teehee)

BACKGROUND:

The Attorney General's Safe Oklahoma Grant Program is a yearly award given to law enforcement jurisdictions. The grant money will be used to purchase two (2) handheld Fentanyl / Methamphetamine Spectrometers, which will be used in the field to test these types of drugs. This is a non-matching grant and will not cost the City of Muskogee any funds.

RECOMMENDED ACTION:

Accept the 2024 Attorney General's Safe Oklahoma Grant Program in the amount of \$17,600.00 or take other necessary action. (Johnny Teehee)

Fiscal Impact

FUNDING SOURCE:

This is grant funded and will not impact the City of Muskogee's fiscal budget.

Attachments

Safe Oklahoma Grant Application

Safe Oklahoma Grant Award Letter & Contract

Resolution 2981





**ATTORNEY GENERAL  
SAFE OKLAHOMA GRANT APPLICATION 2024**

**PREPARED BY THE  
OFFICE OF THE  
ATTORNEY GENERAL OF OKLAHOMA**

**Oklahoma Office of the Attorney General  
Safe Oklahoma Grant Program**

In 2012, the Oklahoma Legislature passed HB 3052 creating a grant program within the Attorney General's office, now known as the Safe Oklahoma Grant Program. The Attorney General is authorized pursuant to 74 O.S. § 20k to "award one or more such competitive grants" to eligible applicants. Specifically, monies will be directed toward strategies that assist in reducing and preventing violent crime.

## **I. AVAILABLE FUNDS**

Appropriations made available through legislation provide a funding stream that, according to law, will be made fully available at the end of each fiscal year. Funds made available through the Safe Oklahoma Grant Program shall be used to supplement, and not supplant, other federal, state, and local funds expended to carry out activities relating to daily law enforcement duties. Grant funds are to be used to enhance the budget of the law enforcement agency, not replace any appropriated funds from the local authority.

## **II. PURPOSE AREA**

To be eligible for a Safe Oklahoma Grant, local law enforcement agencies shall submit proposals to the Office of the Attorney General that focus on decreasing violent crime within their jurisdiction through one of the following priority strategies found at 74 O.S. § 20k(B)(1)-(5), as listed below:

1. Focusing on intervention and enforcement through the use of increased staffing resources with overtime funds to target violent crime with evidence-driven approaches. Policing initiatives may include directed patrols, "hot spot" policing, intelligence-led policing, or youth and gang violence interventions [funds cannot be used for new hires or regular salary and benefits];
2. Increasing technological capacity to support intervention and enforcement with the purchase of technology for crime prevention and criminal justice problem solving. Technology shall include, but not be limited to, crime-mapping software, Global Positioning Systems (GPS) technology and smart phone tools;
3. Enhancing analytical capacity through the development or expansion of analytical capabilities that focus on crime mapping, analysis of crime trends and developing data-driven strategies that focus on violent crime reduction;
4. Engaging with community partners in order to develop partnerships and projects that focus on preventing violent crime in the community. Community partners may include, but are not limited to, public and private service providers, the courts, and probation and parole services. Projects shall include, but are not limited to, programs that focus on drug enforcement efforts, youth violent crime, gang violence, and offender recidivism; and
5. Increasing direct services to crime victims through local law enforcement efforts which shall include, but not be limited to, addressing gaps in crime victims' services by enhancing accessibility to services, increasing awareness of victimization and partnering with local community providers to improve supports and services to victims of crime.

### III. ELIGIBLE APPLICANTS

Awards will be made to local law enforcement agencies across Oklahoma, including police and sheriffs' departments. Cities or counties must be the legal applicant and recipient of funds on behalf of police and sheriffs' departments. It will be necessary to have an authorized official sign the grant application.

### IV. REQUIREMENTS FOR ALL APPLICANTS

All applicants must submit a completed grant application, signed by the authorized official (i.e., the person who is authorized to enter into contracts on behalf of the city or county). Applicants **MUST** include in their application the violent crime rate<sup>1</sup> for the previous five years (2018-2022). When applying for the grant, law enforcement agencies must consider evidence-based techniques that will produce tangible results in their jurisdiction.

### V. GRANT PERIOD

Funds for projects receiving approval will be dispersed upon the Attorney General's Office receipt of an invoice from the agency receiving the funds. The term of the grant period is for one year, beginning on the date the awarded agency receives the funding. Continued funding is not guaranteed. This grant is awarded on an advancement basis and not reimbursement.

### VI. PRIMARY FUNDING CRITERIA

The Office of Attorney General will consider the following factors when awarding funds through the Safe Oklahoma Grant Program:

- Overall quality of the grant application
- Demonstration of need (violent crime reduction is top priority)
- High historical violent crime rates

### VII. APPLICATION PROCESS / DEADLINE

Applicants should describe the problem and indicate how the Safe Oklahoma Grant Program funds will be used to address the reduction of violent crime (attach additional sheets if necessary). Each item requested must be prioritized on the Purpose Area Prioritization Schedule. Equipment and/or technology requests must include a detailed description including the brand name and cost estimate for each item. Personnel requests must be specific and detail exactly how the monies will be spent.

**The completed application must be emailed no later than Friday, July 21, 2023.**

Only those applications that are received by the deadline will be considered for funding. Late or incomplete applications will not be reviewed.

**Email completed applications to: [Stephanie.Lowery@oag.ok.gov](mailto:Stephanie.Lowery@oag.ok.gov)**

---

<sup>1</sup> Consistent with the OSBI's UCR and SIBRS Reports using the categories of murder, rape, robbery, and aggravated assault.

## **VIII. GRANT REVIEW / AWARD PROCESS**

Funds will be awarded based on a city or county's plans for evidence-based practices and deployment tactics, neighborhood targeting, community partnerships, etc. Factors such as violent crime rate, usage of grant funds, demonstration of need, and overall quality of the application will be considered in selecting the grant recipients.

### **INSTRUCTIONS FOR COMPLETION OF GRANT APPLICATION FACE PAGE**

(1) **SUBGRANTEE:**

Enter the name of the local unit of government. Eligible applicants are units of local government such as a city or county.

(2) **AUTHORIZED OFFICIAL:**

Enter the name, title, address, and phone number of the official (city auditor or county auditor) who will receive the state funds, and who will have overall responsibility for the operation and financial administration of the project.

(3) **IMPLEMENTING AGENCY:**

Enter the name of the agency that will have direct responsibility for the grant.

(4) **PROJECT DIRECTOR:**

Enter the name, title, agency, address, phone number, and email address of the person who will have direct responsibility for the overall operation of the project. This person will prepare and submit program reports as required by the Office of Attorney General.

(5) **FISCAL OFFICER:**

Enter the name, title, agency, address, phone number, and email address of the person who will have direct responsibility for the financial administration of the project. This person will prepare and submit financial reports as required by the Office of Attorney General.

(6) **POPULATION OF JURISDICTION**

Enter the population from the most recent US Census for the entire area that the applicant agency serves.

(7) **NUMBER OF LAW ENFORCEMENT OFFICERS**

Enter the total number of law enforcement officers employed by the applicant agency separated by full-time and part-time.

(8) **PRIOR GRANT AWARDS**

Enter the amount of the SAFE grant awards for the applicant agency in 2019, 2020, 2021, 2022, and 2023.

(9) **ALTERNATE FUNDING SOURCES:**

Enter other funding sources that the applicant uses has. This could include other federal grants, county or city appropriations, etc.

(10) **ANNUAL BUDGET**

Enter the annual budget for the city or county law enforcement ONLY.

(11) **DETAIL BUDGET REQUEST FOR THE SAFE GRANT**

Enter the amount of grant funds and items requested. Put the items in order of prioritization with the first request on Line 1 being the highest priority. Place the Purpose Area # to show the request aligns with the SAFE grant priorities.



*Be sure to attach quotes if requesting equipment/supplies.  
You may attach supporting documentation or include  
additional pages if needed.*



**APPLICATION  
2024 SAFE OKLAHOMA GRANT PROGRAM  
OFFICE OF THE ATTORNEY GENERAL**

(1) Name of Subgrantee (City, County) Muskogee Police Department	Title Police Chief	
(2) Name of Authorized Official Johnny Teehee	Phone 918-683-8000	E-Mail Address jteehee@muskogeeepd.org
Mailing Address 112 S. 3rd Street	City State Muskogee OK	Zip Code 74401

(3) Name of Implementing Agency Muskogee Police Department	Title Deputy Chief	
(4) Name of Project Director Chad Farmer	Phone 918-683-8000	E-Mail Address cfarmer@muskogeeepd.org
Mailing Address 112 S. 3rd Street	City State Muskogee OK	Zip Code 74401

(5) Name of Fiscal Officer Dennis Read	Title Finance Director	
Agency City of Muskogee	Phone 918-682-6602	E-Mail Address dread@muskogeeonline.org
Mailing Address 229 W Okmulgee St.	City State Muskogee OK	Zip Code 74401

(6) Population of Jurisdiction	36,738
(7) Number of Law Enforcement Officers Employed by the Agency	85
(8) Prior Grant Awards in 2019, 2020, 2021, 2022, and 2023	No previous Safe Oklahoma Grant awards have been received.
(9) Alternate Funding Sources	The Muskogee Police Department receives funding from the JAG Grant, the City of Muskogee Foundation, and the Muskogee Medical Foundation. However, none of these funding sources include funding for items in this application.
(10) City/County Annual Budget for Law Enforcement	\$5,900,000

**(11) PURPOSE AREA PRIORITIZATION SCHEDULE**

PRIORITY*	PURPOSE AREA	DESCRIPTION	ESTIMATED COST**
<i>EXAMPLE</i>	3	<i>Funds will be used for overtime targeted policing in high violent crime areas.</i>	\$ 75,000.00
1	2	Funds will be allocated to procure three mass spectrometers specifically designated for identifying, solving, and mitigating violent crime related to drug offenses. (estimated cost calculation= 3 x \$8,800)	\$ 26,400.00
2	3	Funds will be utilized to acquire five in-car Mobile Data Terminals (MDTs), replacing the existing outdated ones, with the aim of enhancing technological capacity to support intervention and enforcement efforts. This investment in technology for crime prevention and criminal justice problem-solving will not only improve operational efficiency but also contribute to the reduction of violent crime. (estimated cost calculation= 5 x \$3,200)	\$16,000.00
3			
4			
5			
<b>Total Amount Requested</b>			\$42,400

\*Prioritize each request

\*\*Attach price quote or supporting documentation

From the requests on the previous page, list the portion of your agency's annual budget that is currently allocated on each item.

(Please attach additional pages, if needed.)

ITEM	DESCRIPTION	CURRENT COST
<i>EXAMPLE</i>	<i>Overtime targeted policing in high violent crime areas.</i>	<i>\$ 35,000.00</i>
1	Procurement of three mass spectrometers	\$0
2	Acquisition of five in-car Mobile Data Terminals (MDTs)	\$0
3		
4		
5		

I certify that the project proposed in this application meets applicable requirements of the Justice Reinvestment Grant Program/Safe Oklahoma Grant, that all information presented is correct. By appropriate language incorporated in each grant, or other document under which funds are to be disbursed, the undersigned shall assure that the applicable conditions shown above apply to all recipients of these state funds.

  
 \_\_\_\_\_  
 Signature of Authorized Official

7-17-23  
 \_\_\_\_\_  
 Date



**PROGRAM NARRATIVE**

*NOTE: The grant application will be reviewed based on the narrative provided in this application.  
Use additional pages if necessary to describe the need for grant funds.*

**a. Please list the Violent Crime Rate (per 1,000 people) for your jurisdiction from the following years:**

**2018** 50.93    **2019** 50.22    **2020** 47.20    **2021** 94.13    **2022** \*\*data not yet available

**b. Explain any fluctuation(s) in the Violent Crime Rates listed above.**

The changes in the above crime rates are due to the change in the way crimes are reported as crimes against property, person, and society. While the city's crime rate has increased, the sharp increase is based on reporting changes in addition to the increased crime.

---



---



---



---

**c. Specify the number of occurrences recorded by your agency for the crimes listed in the table below.**

<b>Crime</b>	<b>2018</b>	<b>2019</b>	<b>2020</b>	<b>2021</b>	<b>2022</b>
Murder	2	2	2	2	1
Rape	29	31	31	32	29
Robbery	67	53	43	24	31
Assault (felonious)	228	237	272	229	275
Assault (simple)	583	589	561	500	537

**d. Explain the demographics, hot spot locations and peak seasons of top crime areas in your community.**

*Demographics*

The applicant agency will serve the City of Muskogee, with a population of 36,738. According to the US Census Bureau, 26.5% of the population are under age 18, and 14.8% are over age 65, with the median age being 35.4. Median household income is \$41,430 and 24% of the population are below the poverty level, which is 53.85% higher than the Oklahoma average. 51.3% of the population is white alone; 15.0% Black or African American alone; 15.6% American Indian and Alaska Native alone; 0.9% Asian alone; 11.8% two or more races; 8.3% Hispanic or Latino; and 49.4% White alone, not Hispanic.

*Hot spot locations*

A recent hot spot study found that the west and southwest sections of the city (Districts 36, 37, 38, 39) have an atypically high crime rate in comparison to other parts of the city. The area's boundaries are Main St. on the east, Shawnee Bypass. on the north, Peak Blvd. on the south, and N 64th St. W on the west. The zip code for the identified area is 74401.

*Peak seasons*

During the peak crime season, which typically spans spring until late fall, coinciding with the warmest weather, crime rates tend to reach their highest levels.

**e. Describe how your agency currently tracks changes in violent crime.**

Our agency employs a comprehensive approach to track and analyze violent crime patterns. We rely on the annual OSBI crime reports, which provide a macro-level overview of violent crime trends. We also utilize our records management system to continuously monitor and analyze data throughout the year. We can identify any potential spikes or fluctuations in violent crime occurrences by examining real-time data from r incidents, arrests, and related information. This enables us to promptly recognize emerging trends or areas of concern that require immediate attention. Furthermore, we recognize the significance of officer anecdotal information. Our officers, being on the front lines, possess firsthand knowledge and experiences that provide insights into the nature and dynamics of violent crime within our community. By actively engaging our officers and encouraging their input, we gather qualitative information that complements the quantitative data analysis. This approach ensures a more comprehensive understanding of the situation and aids in formulating effective strategies to address violent crime. This process provides a nuanced understanding of the patterns and trends of violent crime throughout the year. This information forms the basis for our proactive measures, resource allocation, and targeted interventions to address and mitigate violent crime effectively in our jurisdiction.

**f. Please explain how the Safe Oklahoma Grant funds will aid in reducing violent crime.**

The Muskogee Police Department is requesting funds that will be utilized to enhance its capabilities in combating violent crime within the city. Specifically, the department plans to allocate these funds toward the purchase of three mass spectrometers and five Mobile Data Terminals (MDTs). (Please see attached additional pages)

**g. If your office has received a previous SAFE grant (as noted in question 8 above), please describe what was purchased (listed by year for the years 2019-2023)**

No previous SAFE grants have been received.

---

---

---

---

---

---

---

---

---

---

The Muskogee Police Department is requesting funds that will be utilized to enhance its capabilities in combating violent crime within the city. Specifically, the department plans to allocate these funds toward the purchase of three mass spectrometers and five Mobile Data Terminals (MDTs).

The acquisition of three mass spectrometers will significantly aid the department in addressing drug-related crimes, which often exhibit a violent nature. Mass spectrometers are powerful scientific instruments that can identify and analyze substances, providing crucial insights into illicit drugs, explosives, and other materials associated with criminal activities. By employing these advanced devices, law enforcement officers can efficiently and accurately identify substances involved in drug crimes, supporting investigations and facilitating the prosecution of offenders.

As part of the MPD's comprehensive efforts to decrease violent crime, it is our belief that focusing on decreasing drug-related arrests will have an impact on violent crime rates through several mechanisms:

- *Resource reallocation:* utilizing the mass spectrometers will decrease officer time required for substance identification and logging the high volume of drug-related arrests in Muskogee. By shifting these resources to addressing violent crimes, MPD can prioritize efforts to prevent, investigate, and solve violent offenses. This reallocation of resources allows us to focus on more immediate threats to public safety, potentially reducing violent crime.
- *Reduction in drug-related disputes:* Drug use and drug dealing often lead to conflicts and disputes among individuals involved in the drug trade, which often escalate into violence. MPD will utilize the identified technology to quickly identify in-situ bulk controlled substances while on the scene, verify substances during investigations which may include informants and controlled buys, and create criminal linkages to other violent crimes and trafficking organizations. This will enable faster arrests of more organization members, reducing the likelihood of drug-trade violence.
- *Community trust and collaboration:* MPD's comprehensive efforts to decrease drug-related crime is directly-related to voiced community concerns. We believe listening to community concerns around drug crimes is imperative to foster stronger relationships between our department and community members. This collaboration and cooperation will lead to better intelligence gathering, more effective crime prevention efforts, and improved public safety. Additionally, Community trust enables MPD to establish effective channels of communication with community members. This communication allows for sharing of information and intelligence regarding potential criminal activity, including violent crimes. With reliable information from the community, law enforcement can proactively address crime hotspots, target high-risk areas, and intervene in potentially violent situations before they escalate.
- *Incident Linkage:* Identifying illicit substances at the scene provides critical evidence for criminal investigations. By linking the presence and concentration of these substances to violent incidents, MPD investigators can establish connections, identify potential perpetrators, and build stronger cases against individuals involved in violent crimes.

Mass spectrometers are only one part of MPD's comprehensive approach to addressing the social, economic, and educational factors contributing to violence and implementing community-based strategies crucial for effectively reducing violent crime rates.

Additionally, funds will be utilized to acquire five Mobile Data Terminals (MDTs), replacing the existing outdated ones, with the aim of enhancing technological capacity to support intervention and enforcement efforts. This investment in technology for crime prevention and criminal justice problem-solving will not

only improve operational efficiency but also contribute to the reduction of violent crime through several mechanisms:

- *Real-time information access:* In-car Mobile Data Terminals (MDTs) allow MPD officers to access vital information, such as databases, records, and live feeds, directly from their vehicles. This immediate access to information enables officers to make informed decisions on the spot, improving their situational awareness and response effectiveness, and officers can swiftly identify individuals involved in criminal activities, including those associated with violent crime, leading to faster apprehension and intervention.
- *Enhanced communication and coordination:* Mobile Data Terminals (MDTs) enable seamless communication between officers in the field and dispatch centers or other units. Officers can receive and send messages, access radio systems, and collaborate with colleagues in real time, improving coordination and response times. This efficient communication helps officers coordinate efforts during critical incidents, share vital information, and request backup when needed, leading to more effective law enforcement operations and potentially reducing the risks associated with violent crimes.
- *Improved officer safety:* MPD officers are provided with crucial information about potentially dangerous individuals, locations, or vehicles they may encounter in the field. With access to real-time data, officers can be better prepared and take appropriate precautions. They can quickly assess potential threats, access safety alerts, or receive warnings about armed or violent individuals, enabling them to respond more safely and effectively.
- *Evidence collection and documentation:* Mobile Data Terminals (MDTs) have integrated systems for capturing and documenting evidence. Officers can use them to take photos, record videos, or input detailed incident reports directly into the system. This streamlined process enhances accuracy, reduces paperwork, and ensures proper documentation of crime scenes and other crucial evidence for investigations, prosecutions, and building strong cases against violent offenders.
- *Crime mapping and analysis:* Geographic Information Systems (GIS) can be used to provide officers with crime mapping capabilities. They can view and analyze crime patterns, hotspots, and trends in real time, helping them make data-driven decisions and deploy resources strategically. By identifying areas with higher rates of violent crime, MPD can allocate patrols and resources more efficiently, potentially deterring violent crimes and criminal activity and increasing community safety.
- *Efficiency and productivity:* Mobile Data Terminals (MDTs) streamline administrative tasks, such as accessing reports, submitting paperwork, or performing data entry, reducing paperwork burdens for officers. By automating these processes, officers can spend more time in the field, engaging in proactive policing, violent crime reduction efforts and responding to emergencies promptly.

As part of MPD's comprehensive approach to reducing violent crime, the utilization of Mobile Data Terminals (MDTs) is a proactive and efficient strategy to combat violent crime. By reducing administrative burdens and improving data-driven decision-making, these Mobile Data Terminals (MDTs) contribute to the overall goal of reducing and preventing violent crime in our communities.



OFFICE OF ATTORNEY GENERAL  
STATE OF OKLAHOMA

October 4, 2023

*Via Email*

Chief Johnny Teehee  
Muskogee Police Department  
112 S. 3<sup>rd</sup> Street  
Muskogee, Oklahoma 74401

Dear Chief Teehee,

Thank you for your application to the Attorney General's Safe Oklahoma Grant Program. We received a significant increase in applicants this grant period. The Muskogee Police Department has been awarded **\$17,600.00** for the purpose of purchasing two (2) mass spectrometers.

We are pleased your community is taking advantage of this opportunity. Past grantees have proven their efforts to combat violent crime in their communities with the support of this program's funding, and we are proud to partner with you to help achieve the same goal.

Thank you for your commitment to making your community and our state safe. We look forward to working with the Muskogee Police Department. Congratulations on your award for the FY 2024 Safe Oklahoma Grant.

Respectfully,

A handwritten signature in blue ink, appearing to read "Gentner Drummond".

Gentner Drummond  
Oklahoma Attorney General



**THE OFFICE OF ATTORNEY GENERAL**  
**2024 SAFE OKLAHOMA GRANT PROGRAM CONTRACT**

This contract is made between the Office of the Attorney General (“OAG”) and the Muskogee Police Department (“Recipient”) (hereinafter collectively referred to as the “Parties”). OAG agrees to provide funding to Recipient for the purposes provided in Appendix A of this contract and in accordance with the terms and conditions provided in this contract. Recipient agrees to carry out the purposes for funding provided in Appendix A timely and in good faith and to abide by all terms and conditions of this contract.

1. AMOUNT AND PURPOSE OF FUNDS

- a. OAG is providing \$17,600.00 to Recipient for the purchase of two (2) mass spectrometers. The terms of use for the funds are more fully described in Appendix A.

2. AVAILABILITY OF FUNDS

- a. Payment pursuant to this contract is to be made only from monies appropriated to the Office of Attorney General (OAG) by the Oklahoma Legislature for the Safe Oklahoma Grant Program established in Title 74, Section 20k of Oklahoma Statutes. Notwithstanding any other provisions, payments to the Recipient by OAG are contingent upon sufficient appropriations being made by the Oklahoma Legislature. OAG may terminate its obligation under this contract if sufficient appropriations are not made available by the Legislature. OAG may take any action necessary in accord with such determination.

3. TERM OF CONTRACT

- a. The term of the contract begins the date that funds are received by the Recipient.
- b. The term of this contract shall expire twelve (12) months from the date of the Recipient’s receipt of funds unless otherwise agreed in Appendix A or an extension is granted by OAG in writing. The date of receipt of funds by Recipient shall be used as a time reference date for purposes of reporting.

- c. If the funds are not fully spent by the expiration of this contract, Recipient shall return all unencumbered funds to OAG, unless an extension is granted by OAG in writing.

#### 4. MODIFICATION AMENDMENT

- a. This contract is subject to such modification as may be required by law or regulation. Any such modification may be done unilaterally by OAG.
- b. Revisions to the contract and any attachment in Appendix A, which is part of this contract, by Recipient must be approved in writing in advance by OAG.
- c. A waiver by OAG to any provision in this contract must be signed and in writing by OAG.

#### 5. OAG PERFORMANCE

- a. In accordance with the terms of this contract, the OAG will provide funding for the project up to the total amount detailed in Appendix A pursuant to the terms of this contract.

#### 6. RECIPIENT PERFORMANCE

- a. Recipient agrees to perform those duties, obligations and representations contained in this contract and Appendix A, and to be bound by the provisions of this contract and Appendix A, and all amendments thereto, which were submitted to OAG.
- b. In no event shall any subcontract or subcontractor of the Recipient incur obligation on the part of OAG or beyond the terms of Appendix A of this contract.
- c. Recipient shall commence implementation of the project described in Appendix A within sixty (60) days from the date of receipt of funds unless otherwise agreed to in Appendix A or in writing by OAG.
- d. Recipient agrees to cooperate with, and provide information to, any third-party evaluator that has been approved by the Attorney General's Office for the purpose of tracking results of the Safe Oklahoma Grant Program.

#### 7. FUNDING TO RECIPIENT

- a. **Funding will be dispersed only upon receipt of an invoice received by OAG from Recipient for the full amount of the awarded funds.**
- b. Funds made available shall be used only for the purposes and expenses approved by OAG under this contract. These funds are distributed to Recipient who shall be responsible for the payment of all expenses incurred by Recipient in performing



under this contract. The funds provided to the Recipient shall be expended only for expenses incurred during the term of this contract as specified in Appendix A and shall not be expended for expenses incurred prior to, or after, the term of this contract.

- c. Funds made available to Recipient under this grant shall be used to supplement, and not supplant, other funds expended to carry out activities of the Recipient.

#### 8. EMPLOYEE BENEFITS

- a. Recipient acknowledges that the grant funds used to pay overtime are to pay for time worked and not to be used to pay the associated benefits an employee is entitled to in addition to payment for overtime hours worked.
- b. Recipient has full responsibility for the payment of Workers' Compensation insurance, unemployment insurance, social security, state and federal income tax, salaries, benefits, and any other obligations required by law for its employees.
- c. The Parties intend that each shall be responsible for its own intentional and negligent acts or omissions to act. OAG shall not be responsible for the acts and omissions to act of Recipient or any of Recipient's subcontractors or vendors.

#### 9. CERTIFICATIONS BY RECIPIENT

Recipient expressly agrees to be solely responsible to ensure that the use of monies received under this contract complies with all federal, state and local statutes, regulations and other legal authority, including any laws relating to nondiscrimination, equal opportunity, and labor standards.

#### 10. NO-CONFLICT COVENANT

Recipient covenants that no officers or employees of Recipient have any interest, direct or indirect, and that none shall acquire any such interest during their tenure that would conflict with the full and complete execution of this contract. Recipient further covenants that no employee of OAG received anything of value in connection to this contract.

#### 11. NON-COLLUSION

- a. The Parties certify that neither has been a party to any collusion among applicants to the Safe Oklahoma Grant Program, collusion with any state official or employee in the awarding of this grant, or in any discussions with any applicants or state officials concerning the exchange of anything of value for special consideration in awarding this grant.

- b. Recipient has not paid, given or donated or agreed to pay, give or donate to any officer or employee of the State of Oklahoma any money or other thing of value, directly or indirectly, in the procuring of this contract.
- c. No person who has been involved in any manner in the development of this contract while employed by the State of Oklahoma will be employed to fulfill any of the services provided for under this contract.

## 12. PUBLICATIONS AND OTHER MATERIALS

Any material produced in whole or in part as a result of this contract may be subject to the Open Records Act of Oklahoma. OAG shall have authority to publish, disclose, distribute and otherwise use any reports, data or other materials prepared under this contract.

## 13. PROCUREMENT

Recipient agrees and is responsible for ensuring that procurement, management, and disposition of property acquired with contract funds shall be governed by any applicable federal and state laws, including any competitive bidding requirements and requirements for the accounting of public funds.

## 14. RECORDS, REPORTS, DOCUMENTATION

- a. Recipient shall provide a quarterly report every three (3) months to OAG of funds dispersed during the term of this contract and a report detailing the progress of the project. The reporting period shall commence on the date of the Recipient's receipt of funds. Reports shall be due within two (2) weeks of the end of the reporting period. The reports shall include, but not be limited to, the following information:
  - i. A detailed itemization of the funds spent during the three (3) month reporting period (including the attachment of supporting financial documents to the report);
  - ii. An explanation of what was funded under item i. above;
  - iii. The remaining balance of the funds provided under this contract;
  - iv. An explanation of measurement and evaluation tools used to track progress and results;
  - v. An explanation of any observed change in violent crime rates or trends as a result of this project; and
  - vi. A brief narrative of the results, successes, and other observations from this reporting period.
- b. The Recipient shall maintain records and accounts, including property, personnel, and financial records that properly account for all project funds. Recipient shall make these records available to OAG upon request.

- c. Recipient shall keep and maintain appropriate books and records reflecting the services performed and costs and expenses incurred in connection with its performance of this contract for a period of five (5) years from the ending date of this contract. Upon reasonable notice, OAG, the State Auditor's Office, the State Purchasing Director, or their representatives, shall be entitled to access any books, records, and other documents and items directly pertaining to the project funds for purpose of audit and examination, at Recipient's premises during normal business hours. In the event any audit, litigation, or other action involving these pertinent records is started before the end of the five (5) year period, the Recipient agrees to retain these records until all issues arising out of the action are resolved or until the end of the five (5) year period, whichever is later.
- d. Recipient shall provide any status updates during the term of this contract to OAG upon request.

#### 15. CLOSING OUT OF CONTRACT

- a. Recipient shall promptly, but no later than thirty (30) days following the expiration of the contract, return to OAG any funds received under this contract that are not expended for the agreed purposes under this contract in Appendix A.
- b. Recipient shall promptly, but no later than thirty (30) days following the expiration of the contract, submit any closeout documents showing proof of completion of the terms of this contract to OAG.
- c. Recipient agrees to provide any additional information required by OAG after the expiration of this contract for the purpose of showing completion and results of the project.

#### 16. DISPUTE RESOLUTION, INTERPRETATION, REMEDIES, VENUE, AND CHOICE OF LAW

- a. The Parties agree that their authorized representatives will timely meet and negotiate in good faith to resolve any problems or disputes that may arise in the performance of the terms and provisions of this contract.
- b. This contract shall be construed and interpreted pursuant to Oklahoma law.
- c. Venue for any disagreement or cause of action arising under this contract shall be Oklahoma County, Oklahoma.

#### 17. TERMINATION OR SUSPENSION

- a. This contract may be terminated or suspended in whole or in part at any time by written agreement of the Parties.

- b. This contract may be terminated or suspended by OAG in whole or in part, for cause, after notice and an opportunity for Recipient to present reasons why such action should not be taken. Grounds for cause include, but are not limited to:
  - i. Recipient fails to commence implementation of the terms of this contract within 60 days or as otherwise agreed in writing or in Appendix A.
  - ii. Recipient fails to comply with the terms of this contract or with any applicable laws or regulations or is unduly dilatory in executing its commitments under this contract.
  - iii. Purposes for the funds have not been or will not be fulfilled or would be illegal to carry out.
  - iv. The Recipient has submitted incorrect or incomplete documentation pertaining to this contract.
- c. In the event of termination or suspension, Recipient shall be entitled to payment for otherwise valid and allowable obligations incurred in good faith prior to notice of termination or suspension.

#### 18. ENTIRE CONTRACT

This contract, together with Appendix A, constitutes the entire contract between the Parties relating to the rights granted and obligations assumed by the Parties hereunder.

#### 19. HEADINGS

Titles of parts or sections of this contract are inserted for convenience only and shall be disregarded in construing or interpreting the provisions of the contract.

#### 20. SEVERABILITY

If any provision of this contract is held invalid by any court of competent jurisdiction, such invalidity does not affect any other provision of this contract that can be given effect.

#### 21. COUNTERPARTS

The Parties may execute this contract in one or more counterparts, each of which will be deemed an original and all of which, when taken together, will be deemed to constitute one and the same contract. Any signature page delivered by facsimile machine or electronic mail (including any pdf format) shall be binding to the same extent as an original signature page.

22. POINT OF CONTACT

Correspondence and contact to the OAG shall be made through the primary and secondary contact persons listed below:

Primary Contact Name: Stephanie Lowery  
Title: Grants Administrator  
Phone Number: (405) 522-2617  
Email: [Stephanie.Lowery@oag.ok.gov](mailto:Stephanie.Lowery@oag.ok.gov)

Secondary Contact Name: Dane Towery  
Title: Deputy Attorney General  
Phone Number: 405-522-8965  
Email: [dane.towery@oag.ok.gov](mailto:dane.towery@oag.ok.gov)

Agreed to the \_\_\_\_\_ day of \_\_\_\_\_, 2023.

X

  
\_\_\_\_\_  
Chief, Muskogee Police Department

X

  
\_\_\_\_\_  
City Manager, City of Muskogee

X

\_\_\_\_\_  
Stacy Morey  
Senior Deputy Attorney General, Oklahoma Office of Attorney General

## APPENDIX A – Purposes of Funding

The Recipient is required to complete a budget outline for the funds awarded under the terms of this contract and attach as Appendix A.

Appendix A must include a copy of the Recipient's itemized budget for the project with of all items/labor/services to be purchased with funds and provide descriptions and overviews of the activities planned. These documents are attached to this contract and incorporated into the terms and requirements of this contract.

Funding is provided solely for the purposes in Appendix A and shall be spent solely on items in Appendix A.

**RESOLUTION NO. 2981.**

**A RESOLUTION OF THE CITY COUNCIL OF THE CITY OF MUSKOGEE TO APPLY FOR AND ACCEPT GRANT FUNDS FROM THE OPIOID ABATEMENT BOARD OF THE OFFICE OF THE ATTORNEY GENERAL OF THE STATE OF OKLAHOMA SAFE OKLAHOMA GRANT TO FINANCE POLICE DEPARTMENT RESPONSE AND ABATEMENT ACTIVITIES IN THE AMOUNT OF SEVENTEEN THOUSAND SIX HUNDRED DOLLARS (\$17,600.00). BE IT FURTHER RESOLVED THAT THE CITY COUNCIL OF THE CITY OF MUSKOGEE AUTHORIZES THE CITY MANAGER TO SIGN ALL DOCUMENTS RELATING TO THE AWARD.**

**WHEREAS**, the Opioid Abatement Board of the Office of the Attorney General of Oklahoma has made funds available for Opioid Response and Abatement through its Safe Oklahoma Grant Program, and

**WHEREAS**, the grant funds awarded are to be used by the City of Muskogee Police Department to acquire two (2) mass spectrometers for the City of Muskogee Police Department, and

**NOW, THEREFORE**, it was duly moved and seconded that the following resolution be adopted.

**THEREFORE, BE IT RESOLVED** that the City of Muskogee, Oklahoma hereby elects to apply for financial assistance from the Attorney General of Oklahoma Opioid Abatement Board through its Safe Oklahoma Grant Program in the amount of Seventeen Thousand Six Hundred Dollars (\$17,600.00), and authorizes the City Manager of the City of Muskogee, or the Manager's designee, to execute any forms required in the acceptance of said funds.

**ADOPTED, PASSED AND APPROVED** by the Council of the City of Muskogee this \_\_\_\_\_ day of \_\_\_\_\_, 2024.

\_\_\_\_\_  
MARLON J. COLEMAN, MAYOR

ATTEST:

(SEAL)

\_\_\_\_\_  
TAMMY L. TRACY, City Clerk

APPROVED as to form and legality this \_\_\_\_ day of \_\_\_\_\_, 2024.

\_\_\_\_\_  
KATRINA BODENHAMER, City Attorney



**Finance Committee**

**6.**

**Meeting Date:** 04/08/2024  
**Submitted For:** Katrina Bodenhamer, City Attorney  
**Initiator:** Katrina Bodenhamer, City Attorney  
**Department:** City Attorney  
**Staff Information Source:**

---

**Information**

**AGENDA ITEM TITLE:**

Discuss and take possible action related to a Forensic Audit of the City of Muskogee, or take other necessary action. (Councilor Traci McGee)

**BACKGROUND:**

Councilwoman Traci McGee would like to discuss having a forensic audit conducted of the City of Muskogee, and take possible action related to thereto.

**RECOMMENDED ACTION:**

Discuss and take possible action related to a forensic audit.

---

**Fiscal Impact**

**Attachments**

*No file(s) attached.*

---