



Minutes of the Regular City Council Meeting

Held October 20, 2025

7:00 p.m.

A regular meeting of the Oberlin City Council was held on October 20, 2025, in the Council Chambers of the Oberlin City Hall, located at 85 S. Main Street, Oberlin, Ohio. The Presiding Officer, Eboni Johnson called the meeting to order at 7:00 p.m. Roll Call was taken as follows:

1. COUNCIL BUSINESS

- (a) Call Regular City Council Meeting to Order and Roll Call – 7:05 p.m.

Council Members:

	Present	Absent
Joseph Waltzer	<input checked="" type="checkbox"/>	<input type="checkbox"/>
Jessa D. New	<input checked="" type="checkbox"/>	<input type="checkbox"/>
Michael McFarlin, Presiding Officer	<input checked="" type="checkbox"/>	<input type="checkbox"/>
Ray English	<input type="checkbox"/>	<input checked="" type="checkbox"/>
Libni Lopez	<input type="checkbox"/>	<input checked="" type="checkbox"/>
Kristin Peterson	<input checked="" type="checkbox"/>	<input type="checkbox"/>
Eboni A. Johnson, President	<input checked="" type="checkbox"/>	<input type="checkbox"/>

Appointees:

Jon Clark, Interim City Manager/Law Director
 Marin Fowler, Interim Finance Director
 Belinda Anderson, Clerk of Council

- (b) Approval of Minutes – Work Session and Regular City Council Meeting – October 6, 2025

Minutes approved as submitted.

- (c) Proclamation - Indigenous Peoples' Day

New read a proclamation recognizing Indigenous Peoples' Day in the City of Oberlin.

- (d) Consider a Motion not to Object to an Application for the Transfer of a C-1 Liquor Permit from Dollar General to DOLGEN, LLC.

Clark remarked that since there would not be enough members to discuss the item due to recusals and the absence of two members of Council, the Clerk will inform the Department of Liquor Control (DOLC) that Council has declined to request a hearing.

- (e) Discuss and Consider a Recommendation to the City Council from the Open Space and Visual Environment Commission Regarding the Establishment of a Memorial Tree Planting Program

Members of Council considered a recommendation from Martin Buck on behalf of OSVE to establish a Memorial Tree Planting Program. The program will provide residents and community members with a meaningful way to commemorate loved ones, celebrate milestones, or honor significant events through the planting of trees in public spaces throughout Oberlin. This initiative will enhance the city’s urban forest, contribute to environmental sustainability, and beautify our shared public spaces for generations to come.

Buck remarked that the Commission believes this program aligns with Oberlin’s commitment to environmental stewardship, community engagement, and the enhancement of our city’s visual and natural character.

Following remarks New, seconded by Peterson, moved that City Council approve the establishment of this Memorial Tree Planting Program and direct City staff to finalize the administrative guidelines, cost schedule, and public communication materials necessary for a successful launch.

Roll Call:	5 Ayes	0 Nays	Motion Carried
-------------------	--------	--------	----------------

- (f) Discuss and Consider a Recommendation to the City Council from the Open Space and Visual Environment Commission Regarding the Initiation of a Wayfinding and Branding Signage Program

Members of Council considered a recommendation from Martin Buck on behalf of OSVE to adopt a unified wayfinding and branding signage initiative. The Commission believes that by advancing this initiative, Oberlin can build on prior investments, create a cohesive visual identity, and enhance both function and cultural vibrancy across the city.

Buck noted that in both instances, the commission is prepared to assist where needed.

McFarlin commented that the OCIC Downtown Strategies Subcommittee had weighed in on design and wayfinding. He wondered if that had been discussed in the context of coming up with the recommendation. New replied that it had been.

McFarlin recalled that the company that assisted the Oberlin Community Improvements Corporation offered to provide a reference for a wayfinding firm that could be retained at a reasonable cost. He also suggested that Oberlin school district and the College be involved in this process to ensure coordination in signage. He also mentioned the need to reach out to the Comprehensive Plan Implementation Committee to avoid duplication of effort, since this is also listed as part of the Comprehensive Plan Subcommittee's goals.

New summarized the process that was used to reach the commission’s decisions. She noted that it was important for the Council to move forward on this to fulfill its obligation under the comprehensive plan, which supports this project.

New, seconded by McFarlin, moved that the City adopt a unified wayfinding and branding signage initiative to enhance Oberlin’s identity, facilitate navigation, support economic vitality, and reflect the city’s cultural and environmental values.

Roll Call: 5 Ayes 0 Nays Motion Carried

2. ANY CONCERNS NOT ON THE AGENDA MAY BE BROUGHT TO THE ATTENTION OF THE COUNCIL AT THIS TIME

- Aliza Weidenbaum, 99 South Cedar Street, remarked that, given these times of political division and cultural division she had prepared something for the record, she read:

With many tough problems, such as racism and bodily autonomy. These have both legal and cultural elements. Certain legal equalities and guarantees need to be put in place. But then a huge bulk of the work is at the cultural level, warming up hearts and persuading minds. And that is not done through a City Council ordinance. And sometimes over-politicizing can result in backlash.

So, when I think of the role of government, specifically, the role of City Council. I am urging you all to keep in mind what should be done as a matter of policy, versus what should be done as a matter of the bully pulpit, by expressing attitudes in resolutions as elected representatives, whether attitudes of welcoming and belonging or attitudes of unwelcoming and condemnation, versus what probably shouldn’t be done from a government position at all. Especially when it pertains to realms of society which have their own authority. Whether that is athletics, religion, or these days with the internet simply online business reviews and product reviews for products that might change your skin, hair, or body, to reviews of professional service providers.

Second, not all tactics fit all causes. We don’t like bans when people try to ban books. Some banned books become everlastingly popular. We know that banning businesses that sell alcohol simply didn’t work. We know what a speakeasy is, it’s a place with a code word to continue doing what is banned. You might want to consider bans on some type of explosives, chemicals, or machine guns, though sometimes other policies might be more effective, such as gun buy-backs. There are major differences between banning chemicals that poison the water and air of everybody versus banning physical products, personal services, and forms of expression in speech. So please think carefully about any ban, any tactic, or method.

Finally, regarding the First Amendment rights of speech and association, we have to remember the very nature of truly protecting rights and freedoms and of the golden rule. I feel most protected when I know that even people who have opposite beliefs and opposite tendencies from me have their rights. Then I am assured that my rights are real and firm. If I don’t want someone to ban my ability to talk with whomever, about whatever topics I want and need to talk about at any age, and yes, maybe that is talking about abortion with a doctor. I cannot ban their ability to talk to whomever about whatever topics they want and need to discuss. Free speech about whether it is about the condition of my uterus, or the sexual thoughts in my head, it is something that needs consistent protection. Free speech means that it is not the role of government to make rules about speech. So that our culture can advocate passionately on both sides of any issue.

- Maureen Simen, League of Women Voters of Lorain County, promoted National Voter Early Registration Day, which is Tuesday, October 28, 2025. We have a General Election coming on November 4, 2025, with several important races and tax issues on the ballot for Oberlin residents. Ensuring all registered voters can exercise their right to vote is a top priority of the League of

Women Voters, and we, of course, value all avenues of voting equally, but “Vote Early” is an important opportunity to highlight this option. Ohioans have two options for voting early: they can request an absentee ballot or vote early in person at their Board of Elections. She remarked that if anyone had questions or concerns, they could call the Board of Elections at 440-326-5900, or learn more about the candidate and the issues at the League of Women Voters elections information website at vote411.org. However, you decide to vote, whether early or on Election Day we at the League of Women Voters of Lorain County thank you for exercising this important right.

- Jill Sawyer, 12 East Vine Street. Remarked that she is here to provide perspective on what it is like to live in the midst of the East Vine Street Bridge project, which has been extremely fascinating from her picture window, which looks just over the site. She pointed out that most people are familiar with the Road Closed sign at the East Vine/Main Street intersection and might think it’s just another standard road construction project. She and the residents of 15 and 19 East Vine Street see things quite differently. Our homes are literally at the edge of a crevasse, a deep, often muddy hole below that has frequently filled with water in the past few weeks. She is aware that there have been some complications lately.

The conservatory student who lives in the white house across from her has bulldozers directly outside their windows. The steep cliff that has been created next to their house is buttressed by temporary wood supports, which have been added to as the weeks go by and the site expands eastward. She imagines that this is nerve-racking for them, and then there is the noise nuisance.

First, it was a gas-powered generator that had been keeping us up at night. That was eventually moved, but now we have a huge pump at the north end of the work site, which continues to operate on and off all day and all night, powered by the water that has flooded into that big hole where Vine Street used to be. She has heard that the conservatory students have reported staying up all night, which is impacting their ability to perform and do their work at the college. She can guarantee everyone in this room, that no one would want to be in this position.

What also keeps her up at night is the lack of communication from the City. This has been disappointing. In the beginning, her neighbors didn’t know where to park their cars, where to put their garbage and recycling bins on pick up day, or even how their packages would get to their doors. She has gathered this information by making phone calls and has been sharing the information with her neighbors. The positive in all of this is the construction company, which has been incredibly proactive and has reached out to her to let her know when there will be extremely disruptive construction and what their work schedules will be. She emphasized that this didn’t feel like a typical standard construction project. A massive piece of road is gone, and the schedule isn’t clear anymore. We used to hear that the project would run from August to December, but now we don’t know what is coming up. She wished there was a way to insulate the sound of the pump, and that the students had been offered relocation so they could sleep at night.

- Residents of Edgemere Place, including Kay Zimmer (360 Edgemere Place), Carol Hoffman (366 Edgemere Place, and Barbara Hill (355 Edgemere Place), addressed the City Council to express ongoing concerns about conditions on their street. Speakers reported a persistent odor resembling natural gas, believed to be caused by an aging sewer line dating back to the 1930s, and emphasized potential health and safety risks if the issue continues. Residents also requested that the City prioritize replacing the sewer line before repaving the street, citing the poor pavement condition, uneven sidewalks, and accessibility challenges for individuals using mobility devices. They asked that these improvements, which are consistent with the City’s strategic plan, be considered in the upcoming budget discussions.

- Linda Rothacker, POB 613, noted that several parking spaces in front of City Hall have been commandeered and suggested that the City Council implement a two-hour parking limit.

3. OPPORTUNITY FOR A REPORT FROM A CITY BOARD OR COMMISSION REPRESENTATIVE

4. OPPORTUNITY FOR A REPORT FROM AN ADMINISTRATIVE DEPARTMENT REPRESENTATIVE

Members of Council heard updates from Public Works Director Jeff Baumann regarding several infrastructure projects and concerns.

East Lorain Street and Oberlin Road Intersection

Baumann explained that the City has contracted with the GPD group to assess the intersection. Their review will include an evaluation of traffic movement, a speed study, and a review of crash history records to determine whether improvements such as a conventional traffic signal, a four-way stop, or other measures are warranted.

East Vine Street Bridge and Sanitary Sewer Replacement Project

Mr. Baumann provided an update on the ongoing project. He noted that the brick around the 60-inch storm sewer will need to be replaced due to corrosion. In addition, replacement of the sanitary sewer was discussed. Baumann explained that it cannot be replaced in its existing location and reviewed the proposed solution. He noted that collectively this will result in a \$110,000 change order and an additional \$10k to American Structurepoint for additional design work.

Council Member McFarlin asked how this plan addresses Ms. Sawyer's concerns about the project timeline. Mr. Baumann responded that a meeting is scheduled for the following day to discuss those issues further; at this time, they do not have a revised scheduled.

New expressed support for pursuing the option that provides the most efficient solution possible while minimizing future disruption for residents affected by the work.

Edgemere Street Pavement Inventory Report:

Waltzer asked Mr. Baumann to review how he uses his pavement inventory report to track pavement conditions across the community and how that is used to determine when a street improvement project will be done. Baumann provided an overview of his process. He noted that all information they are able to collect is integrated and balanced with the budget to guide maintenance and improvement decisions.

5. OLD BUSINESS:

- A. Ordinance No. 25-53 AC CMS: An Ordinance Authorizing the City Manager to Enter into an Agreement with the Nord Family Foundation for the Cooperative Use, Maintenance, Repair, and Improvement of Shared Improvements at Depot Park and the Depot Building Property (2nd)

The Clerk read the Ordinance by number and title only.

New, seconded by Waltzer, moved to approve the Ordinance on second reading.

Baumann commented that staff members are not seeking immediate passage at this time. Late last week, they received additional feedback from Legal Counsel representing the Nord Family Foundation. Many of the requested changes are non-material to the City, and staff have agreed to those revisions. However, two remaining points are still under review by him and Law Director Clark.

He noted that the Nord Family Foundation Board held its quarterly meeting on Saturday and approved the agreement, contingent upon their legal counsel's final approval. Staff anticipates that the outstanding matter will be resolved by the November 3 regular City Council meeting and therefore asks Council withhold immediate passage until that time.

Baumann added that the good news is the Nord Family Foundation Board agreed to budget funds for their share of the brick pavers as part of a larger project and has also agreed to cost-share the reconstruction of their portion of the parking lot and driveway next year.

Roll Call: 5 Ayes 0 Nays Motion Carried
(Second Reading)

6. NEW BUSINESS:

- A. Ordinance No. 25-54 AC CMS: An Ordinance to Approve the Form and Authorize the Execution of the 2027 Waste Heat Energy Schedule with American Municipal Power, Inc. and Taking of other Actions in Connection Therewith to Go into Immediate Effect

The Clerk read the Ordinance by number, title, and substantive portions.

Peterson, seconded by McFarlin, moved to approve the Ordinance on first reading.

Skolnicki remarked that the City has an opportunity to enter into a power purchase agreement for Waste Heat Energy. He explained that the agreement would provide baseload renewable energy, with the City subscribing to 1.9 megawatts, representing approximately 14% of its total power supply. Currently, the City's power supply is running at about 80 - 85% renewable. Participation in this project would further increase the share of renewable energy; however, staff must take into consideration that the existing landfill gas contracts will expire at the end of 2027. When those contracts expire, the City will experience a gap in its renewable energy portfolio. AMP has begun discussions with Waste Management to determine whether those landfill gas contracts can be extended, but no agreement has been reached to date.

Following his remarks, Paul Beckhusen, Senior VP of Power Supply Planning and Generation Operation for AMP Ohio, provided City Council with a Power Supply Update. A copy of the presentation is attached to the minutes.

Councilmember McFarlin asked whether the 2% annual escalation was included in the agreement. He also asked whether AMP was confident that the landfill gas contracts set to expire in 2027 could be replaced.

Beckhusen confirmed that the 2% annual escalation is built into the agreement. He stated that it may be possible to extend the Erie County Landfill Gas Agreement, though he was less optimistic

about being able to renegotiate the same level of participation in the Waste Management Landfill Contract.

McFarlin further inquired whether the City would have an opportunity to acquire additional shares from the Erie County Landfill project.

Beckhusen explained that since increased output is expected from the Erie County Landfill, all current participants would receive a proportional increase in their allocations, provided that no current participants withdraw from the project. If any participant were to withdraw, Oberlin may have the opportunity to acquire their share.

Following the presentation, Peterson, seconded by McFarlin, moved to waive the three-reading rule for Ordinance No. 25-54 AC CMS.

Roll Call: 5 Ayes 0 Nays Motion Carried
(Suspension of Rules)

Peterson, seconded by McFarlin, moved that Ordinance No. 25-54 AC CMS go into immediate effect to assure that the electric capacity and energy requirements of the City of Oberlin's electric utility system are satisfied.

Roll Call: 5 Ayes 0 Nays Motion Carried
(Effective Immediately)

- B. Ordinance No. 25-55 AC CMS: An Ordinance Adopting the Recommendation of the Oberlin Planning Commission to Approve the Final Development Plan for the Development to be Known as "Oberlin Place" on Property Located at 450 West College Street

The Clerk read the Ordinance by number, title, and substantive portions.

Peterson, seconded by McFarlin, moved to read Ordinance 25-55 AC CMS on the first meeting.

Porter remarked that this is the final development plan for Oberlin Place, which the Planning Commission is requesting Council to approve. As required under the Development Overlay District rezoning, Council must adopt the final development plan by ordinance.

The plan provides for 62 affordable housing units and 78 parking spaces. The applicant has addressed all of staff's comments. Some adjoining residents expressed concerns regarding screening and landscaping: in response, the applicant submitted a revised landscaping plan that incorporates fencing and additional plantings along the property lines to buffer neighboring residences.

The applicant also submitted a lighting plan to mitigate light pollution. The photometric study indicates zero light levels along all property boundaries except at the front entrance, where lighting and signage will be located.

A key change in this final plan pertains to the sidewalk configuration, which was modified to address accessibility issues identified by the City Engineer at the main entrance, though the overall site layout remains consistent with the preliminary plan.

Roll Call: 5 Ayes 0 Nays Motion Carried
 (First reading)

- C. Ordinance No. 25-56 AC CMS: An Ordinance Declaring 8.6994 Acres of Real Property Located on U.S. Route 20 to be Surplus and Authorizing the City Manager to Sell Said Property to GPH Holdings, LLC to Go into Immediate Effect

The Clerk read the Ordinance by number, title, and substantive portions.

New, seconded by McFarlin, moved to approve the Ordinance on first reading.

Clark remarked that this ordinance serves as an invitation to consider an offer from GPH Holdings to purchase 8.6994, of City-owned land. GPH owns the property where Game Day Soccer operates and has requested to purchase the adjacent City parcel to expand its operations.

Because the City is retaining approximately three acres at the front of the site for its electric facility, the buyer would be required to combine the newly acquired property with its existing parcel to meet Planning Commission requirements. The property would be subject to a 50-foot utility easement to allow the City to extend utilities from the substation to the remainder of the industrial park.

Clark noted that the \$22,000 offer is lower than what is anticipated for the sale of the remaining Industrial land; however, the parcel in question is not suitable for industrial development and is encumbered by the easement. The purchase agreement is not yet attached and would need to be formalized and brought back to Council. Therefore, this item is being presented for first reading only.

Roll Call: 5 Ayes 0 Nays Motion Carried
 (1st Reading)

- D. Resolution No. R25-13 CMS: A Resolution Accepting the Amounts and Rates as Determined by the Budget Commission and Authorizing the Necessary Tax Levies and Certifying Them to the County Auditor Pursuant to Ohio Revised Code Section 5705.34 to Go into Immediate Effect

The Clerk read the Resolution by number, title, and substantive portions.

Peterson, seconded by Fowler, approved the Resolution on first reading.

Fowler explained that this resolution is approved each year. Although the levies have already been approved by the voters, Council still needs to request that the County Auditor levy the taxes for the coming year. The deadline for this is October 31, 2025.

New, seconded by Peterson, moved to waive the three-reading rule for Resolution No. R25-13 CMS.

Roll Call: 5 Ayes 0 Nays Motion Carried
 (Suspension of Rules)

New, seconded by Peterson, moved that Resolution No. R25- 13 CMS go into immediate effect to ensure the property tax rates are approved and submitted to the County Budget Commission and County by the October 31, 2025, filing deadline.

Roll Call: 5 Ayes 0 Nays Motion Carried
(Effective Immediately)

- E. Resolution No. R25-14 CMS: A Resolution Petitioning the Board of Commissioners of Lorain County, Ohio, to Extend the Current Boundary of Oberlin Township to include Territory Recently Annexed to the City of Oberlin, so the Boundaries of Said Township Conform to and are Accepting the Amounts and Rates as Determined by the Budget Commission and Authorizing the Necessary Tax Levies and Certifying Them to the County Auditor Pursuant to Ohio Revised Code Section 5705.34 to Go into Immediate Effect

The Clerk read the Resolution by number, title, and substantive portions.

Peterson, seconded by New, moved to accept the Resolution on first reading.

Clark explained that the Council has approved several annexations, and the final step is to request that the County Commissioners adjust the boundaries of the recently annexed areas so they fall entirely within the City of Oberlin. Approval from the County Commissioners is required before the boundary changes take effect.

New, seconded by Peterson, moved to waive the three-reading rule for Resolution No. R25-14 CMS.

Roll Call: 5 Ayes 0 Nays Motion Carried
(Suspension of Rules)

New, seconded by Peterson, moved that Resolution No. R25-14 CMS go into immediate effect to memorialize conformance of recently annexed territory to the City of Oberlin to clarify taxation and voter eligibility.

Roll Call: 5 Ayes 0 Nays Motion Carried
(Effective Immediately)

5. COUNCIL COMMUNICATIONS:

(A). Referrals

(B). Advocacy

(C). Correspondence

(D). Reports

Council members provided updates on board and commission meetings, initiatives, community events, upcoming legislative items for boards and commissions handbook and Council Rules, and announced upcoming meeting dates.

6. CITY MANAGER'S REPORT:

City Manager Holcomb reminded everyone that the Halloween Parade will be Saturday, October 25th. Halloween will be on the 31st from 6:00 to 7:30 p.m.

7. OPPORTUNITY FOR OTHER APPOINTEES TO REPORT:

Clerk of Council Anderson reported that she received notification that the annual Ohio Municipal League membership dues of \$1,528 are due and asked if Council wished to renew. She highlighted several benefits of membership. Council approved renewing the City's membership.

8. PUBLIC PARTICIPATION:

Carol Hoffman, 366 Edgemere Place, asked how residents will know if the project will be included in the budget. Johnson replied that this will require coordination with the City Manager, Public Works, and Finance Director. Ms. Hoffman then asked if they could expect to hear back from the City Manager regarding the outcome of their request during the budget process. Johnson confirmed that they would and invited residents to attend the upcoming budget work sessions, where this would be discussed.

9. ADJOURNMENT:

Being that there was no additional business before Council, the regular meeting adjourned at 8:59 p.m.

Attest:



BELINDA B. ANDERSON, MMC
CLERK OF COUNCIL



EBONI A. JOHNSON
PRESIDENT OF COUNCIL

APPROVED: 11/03/2025

POSTED: 11/04/2025

City of Oberlin Power Supply Update

October 14, 2025

Mike Migliore - VP of Power
Supply Planning



Oberlin Monthly Energy Totals

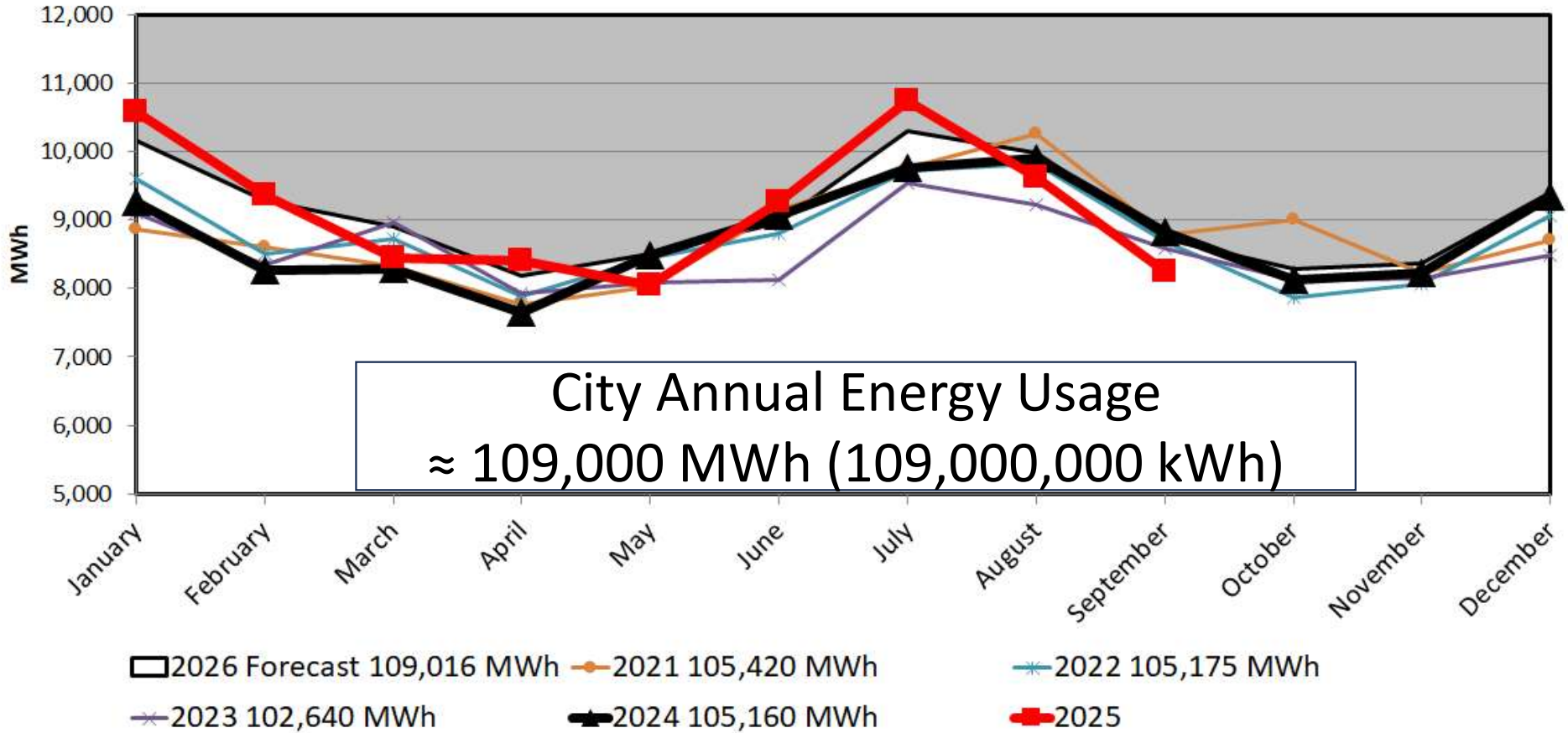

Peak Demand

Oberlin	2025	2024	2023	2022
Peak Demand (MW)	20.94	20.73	20.47	21.07
Month & Day	Jun 26	Aug 27	Sep 05	Jun 16
Hour Ending (EDT)	15	15	16	14
Temp. During Peak	89°	91°	87°	91°

Total City Peak including EDL is 26.816 MW on June 26 at 1500

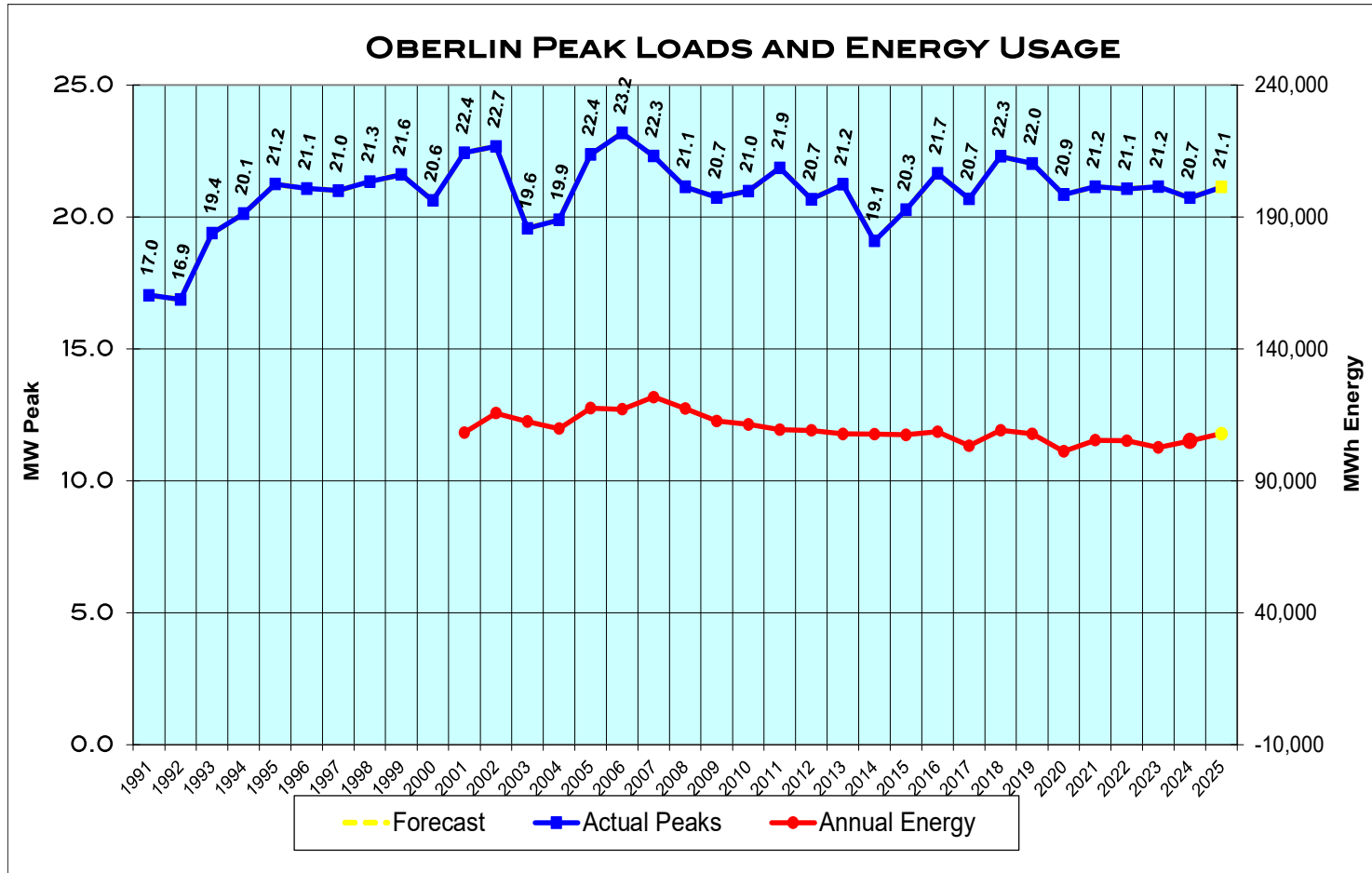



Delivery of Power (3 Types of Charges)

- Transmission
 - High Voltage (69 kV) electric lines delivering power to municipal system
 - Fixed cost (\$/ kW-mo) based on Oberlin meter at time of FirstEnergy peak (summer)
- Installed Capacity
 - Ensuring that there is enough generation in place to supply customers during period of maximum usage
 - Fixed cost (\$/ kW-mo) based on Oberlin meter at time of PJM five highest peaks (summer)
- Energy
 - Kilowatt-hours consumed by customers and produced by generators
 - Variable cost (\$ / MWh, cents / kWh)

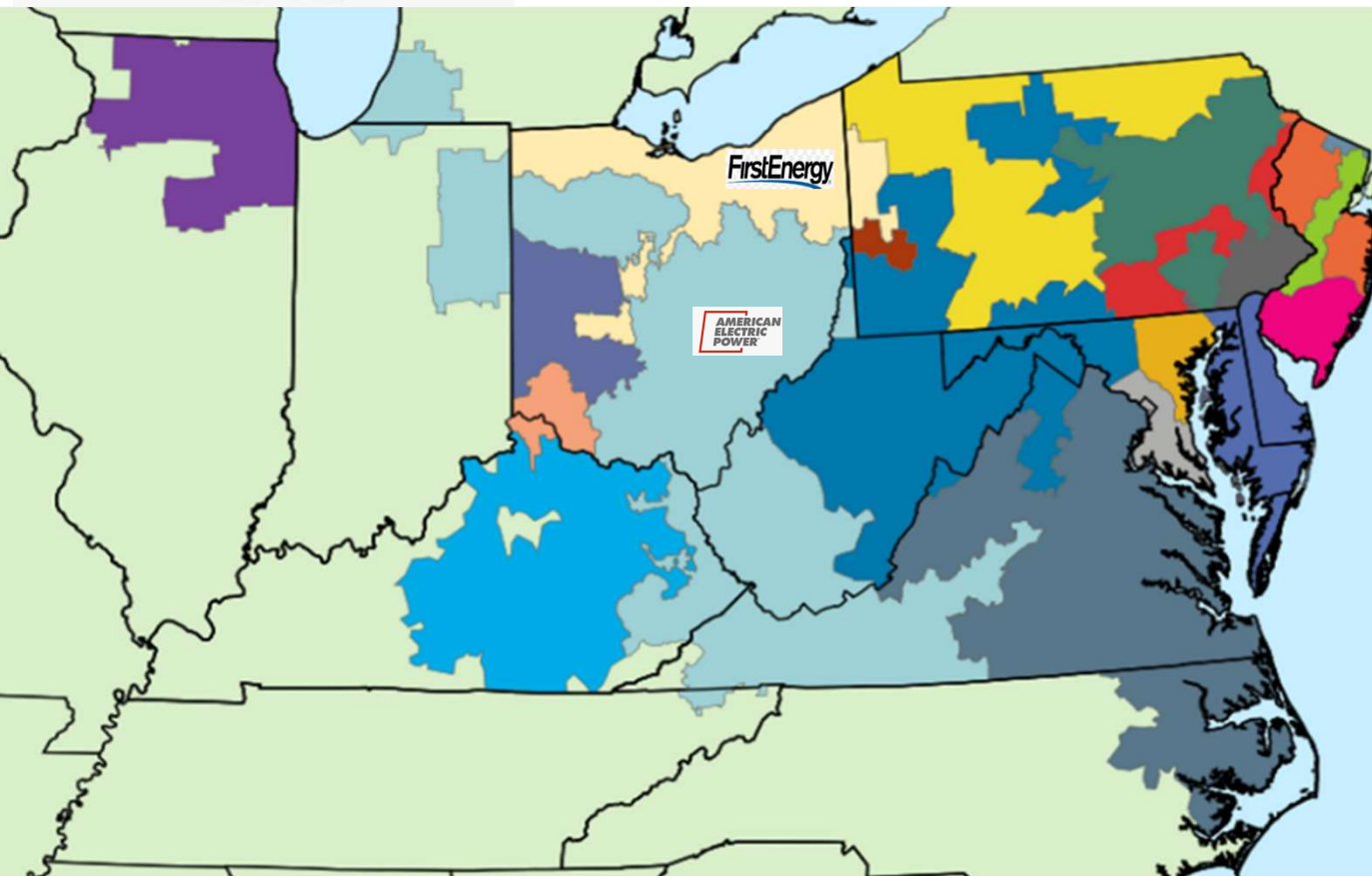

1. Economically Dispatch power plants (PJM pays generators for energy)

[hourly auction]

2. Keep the Lights on (PJM pays generators to be on call for emergency)

[annual auction]

Normal Power Flow into Oberlin

- Power metered from transmission system to municipal electric system

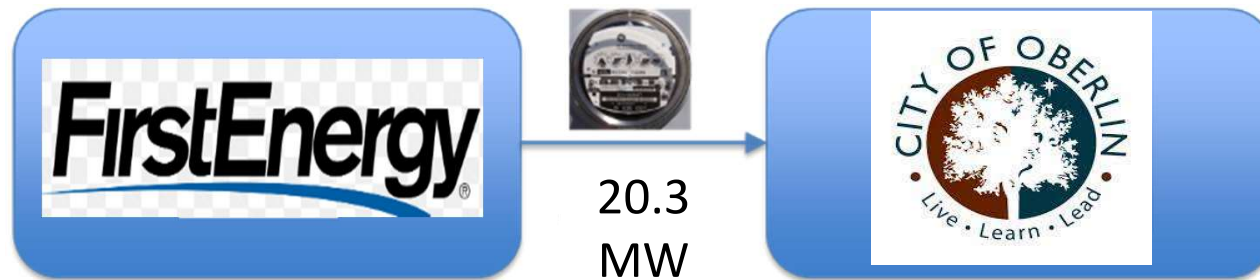

Behind the Meter Generation (BTM)

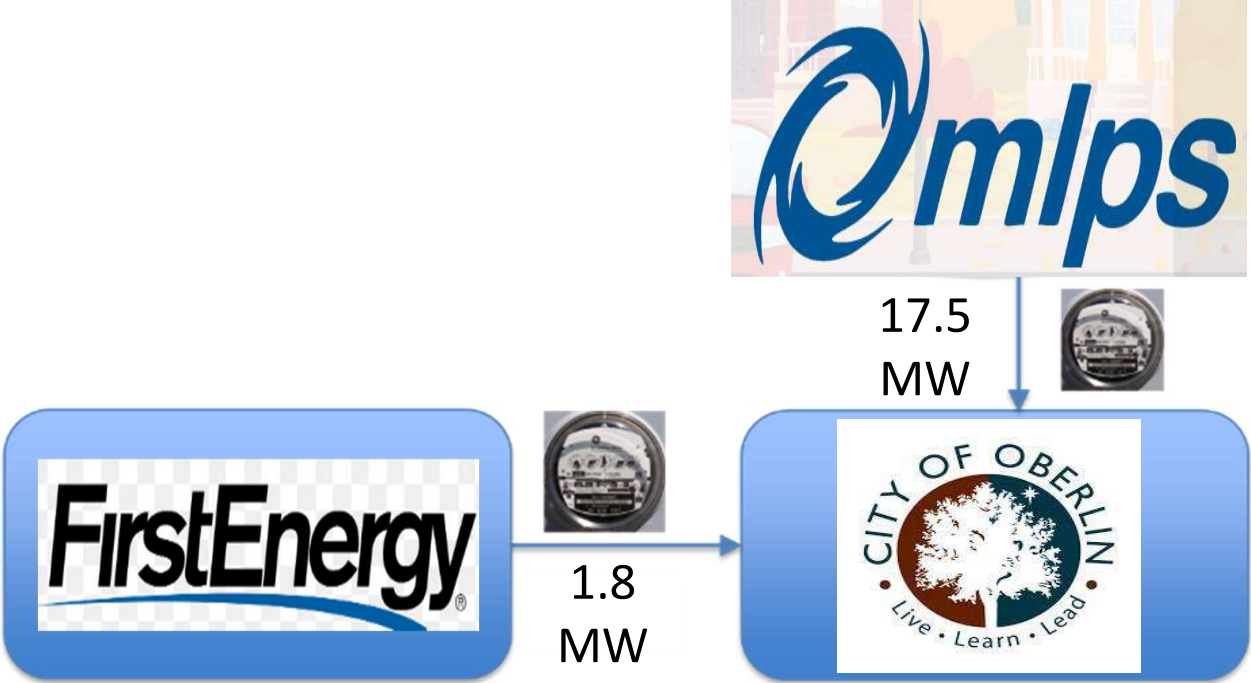

- Operation of Oberlin Power Plant saves \approx \$1.8 million per year in transmission costs (\$16 / MWh or 1.6 cents)



\$14 billion per year starting
June 2025 vs. \$2 billion in 2024

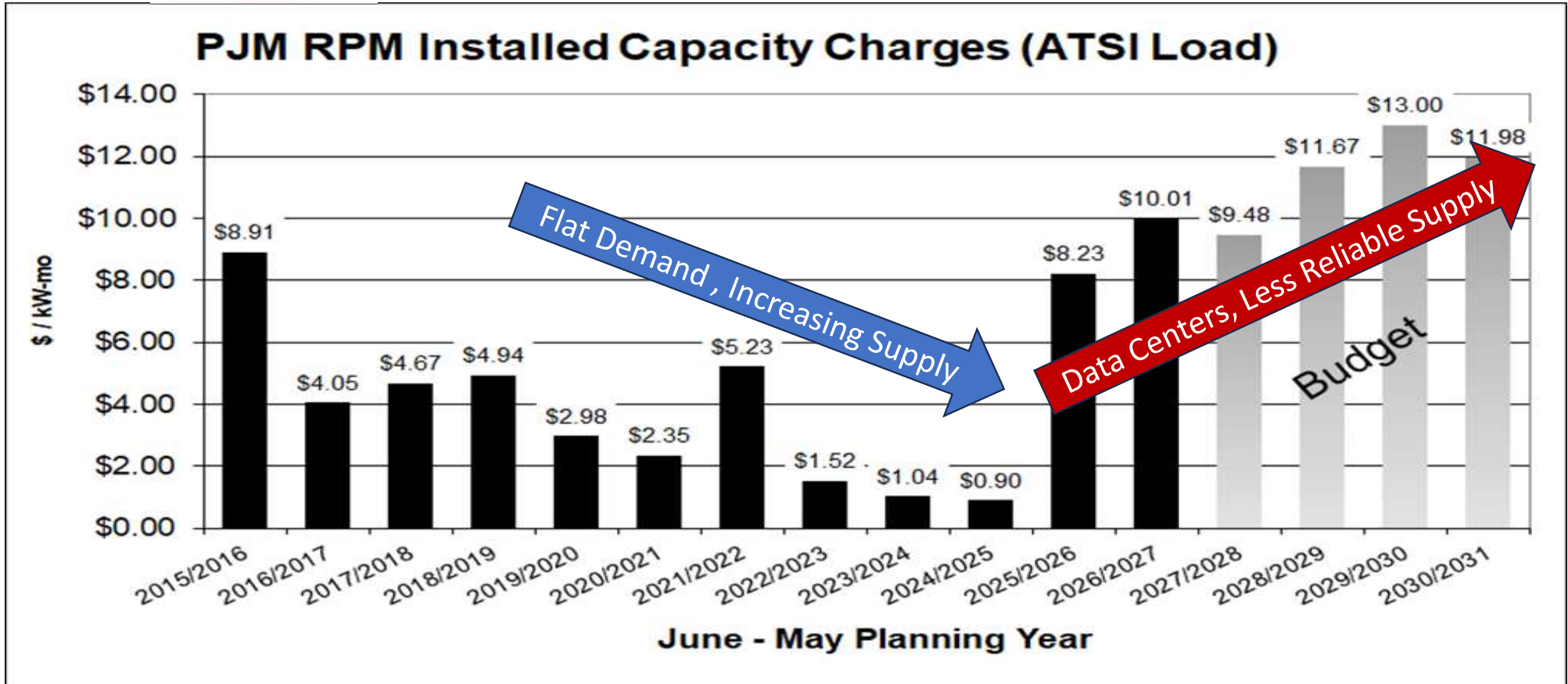

The capacity cost increase in Ohio means residential customers will see a 10-15% increase in their bills for June 2025 – May 2026, or around 2 cents per kWh. Businesses can expect an increase of up to 29%.

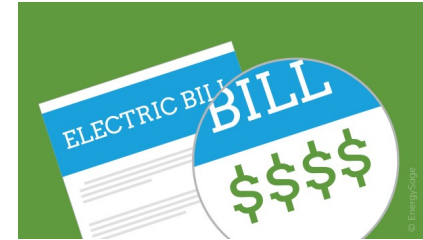

Operation of Oberlin Power Plant in summer of 2025 saved \approx \$2,000,000 per year in capacity costs (\$18 / MWh or 1.8 cents / kWh)

Total One Year Savings from Oberlin Power Plant is **\$3.8 million.** (~45 hours of operation)

Reduced Oberlin Customers' power costs by 3.4 cents / kWh

Oberlin 2025 Monthly Rates

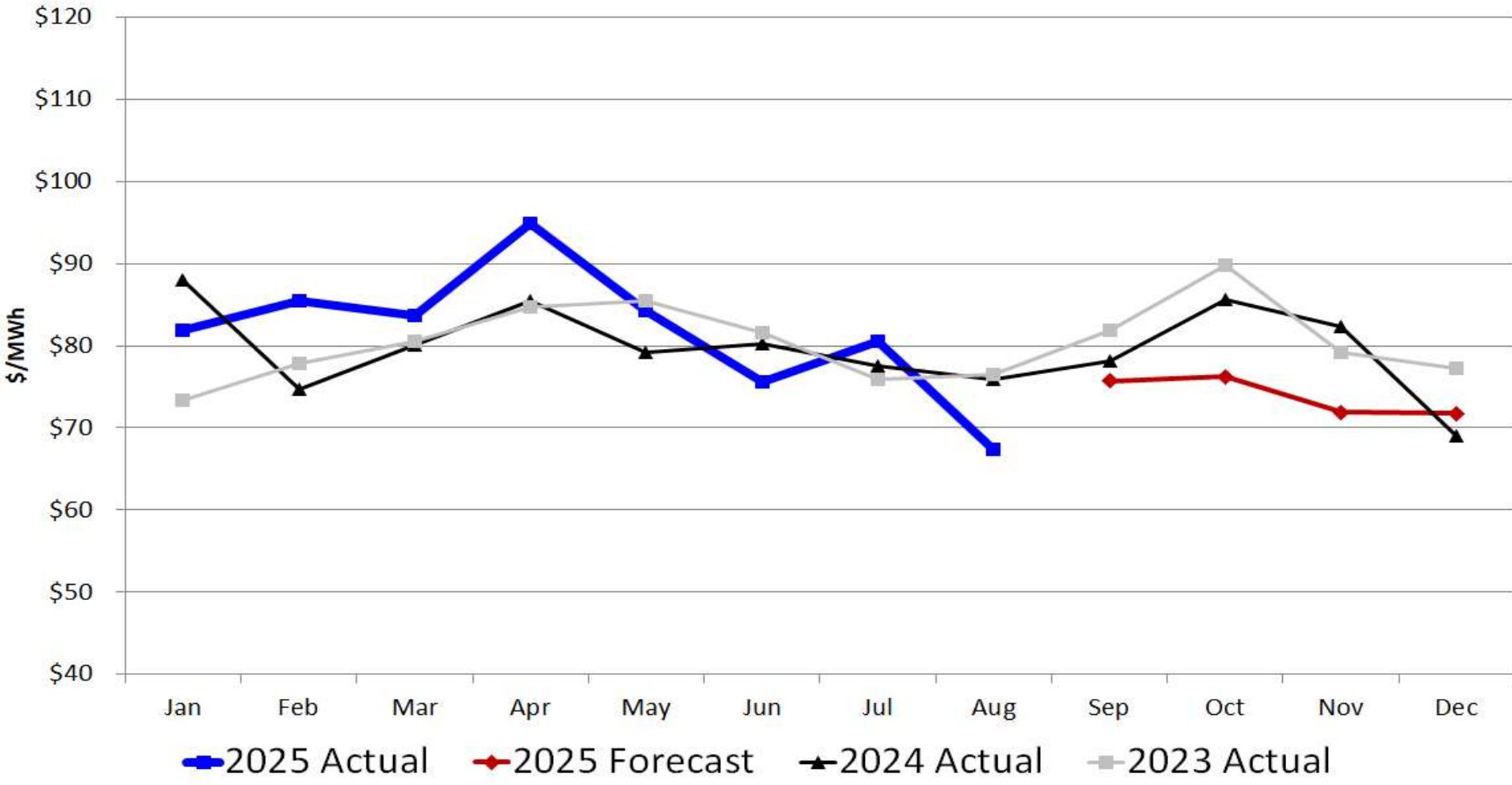

***POWER
SOURCES***



Oberlin Energy Sources

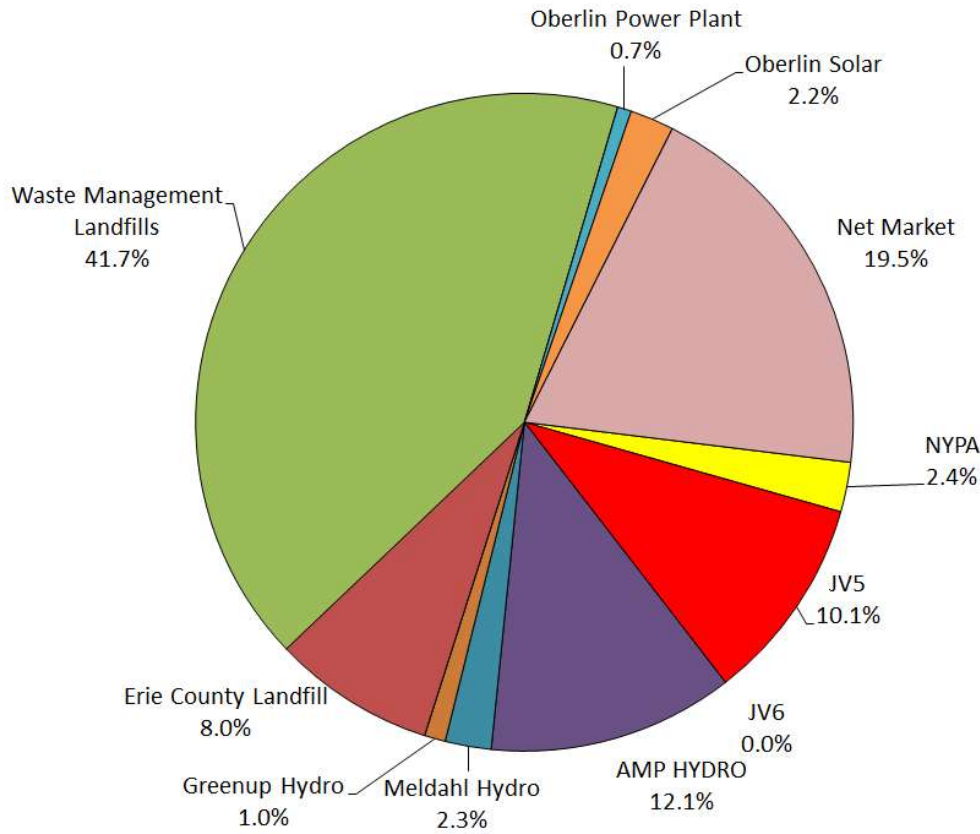

Hydro Plants and Ohio River Watershed

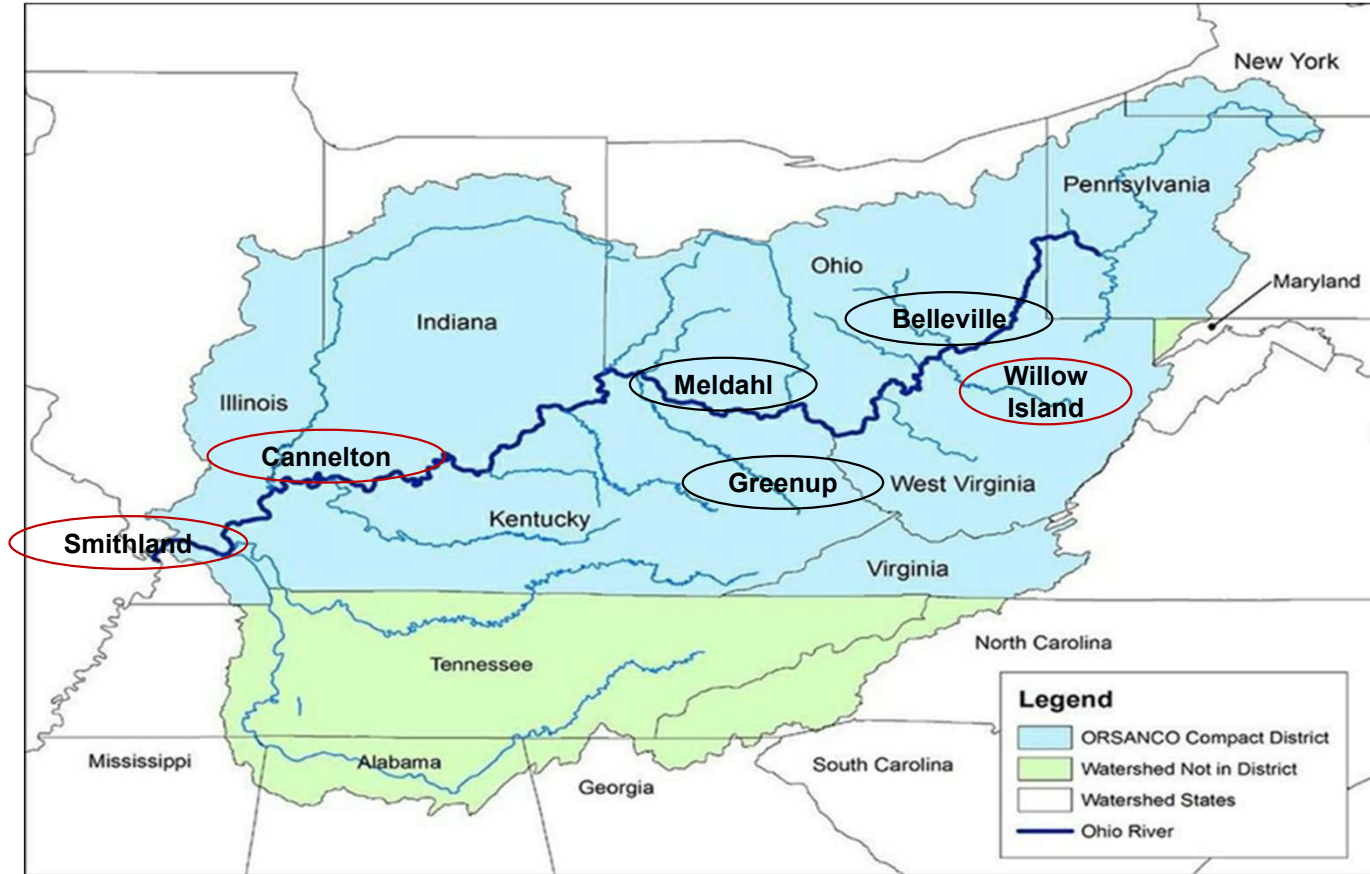

OMEGA JV5 (1,270 kW)

- 42 MW Belleville hydro project (on line 1999)
 - **Oberlin is 3.02% owner of project**
 - Debt collection through 2029
 - Approximate net rate of \$27 / MWh

NYPA (473 kW)

- New York Power Authority
- **Purchase Power Agreement**
- Current License through 2032
- Approximate net rate of \$10 / MWh



Weighted Cost of
Oberlin Hydro =
\$82 / MWh

AMP Hydro (2,598 kW)

- 208 MW project (on line 2016)
 - **Oberlin is 1.25% of project**
 - Debt collection through 2049
- Approximate net rate of \$139 / MWh

Meldahl (504 kW)

- 105 MW project (on line 2016)
 - **Oberlin is 0.48% of project**
 - Debt collection through 2049
- Approximate net rate of \$67 / MWh

Greenup (330 kW)

- 70.2 MW project (on line 1982)
 - **Oberlin is 0.47% of project**
 - Debt collection through 2045
- Approximate net rate of \$97 / MWh

Erie County Landfill (1,000 kW)

- Purchase Power Agreement through December 2028
- Located near Milan, Ohio in FirstEnergy
- Approximate net rate of \$40 / MWh
 - After Installed Capacity and 50% of RECs
 - RECs sold in Pennsylvania market



Waste Management Landfills (5,400 kW)

- Purchase Power Agreement through December 2027
- Located near Geneva, Ohio and New Springfield, Ohio (Mahoning County)
 - FirstEnergy
- Approximate net rate of \$50 / MWh
 - After Installed Capacity and 100% of RECs
 - RECs sold in Pennsylvania market



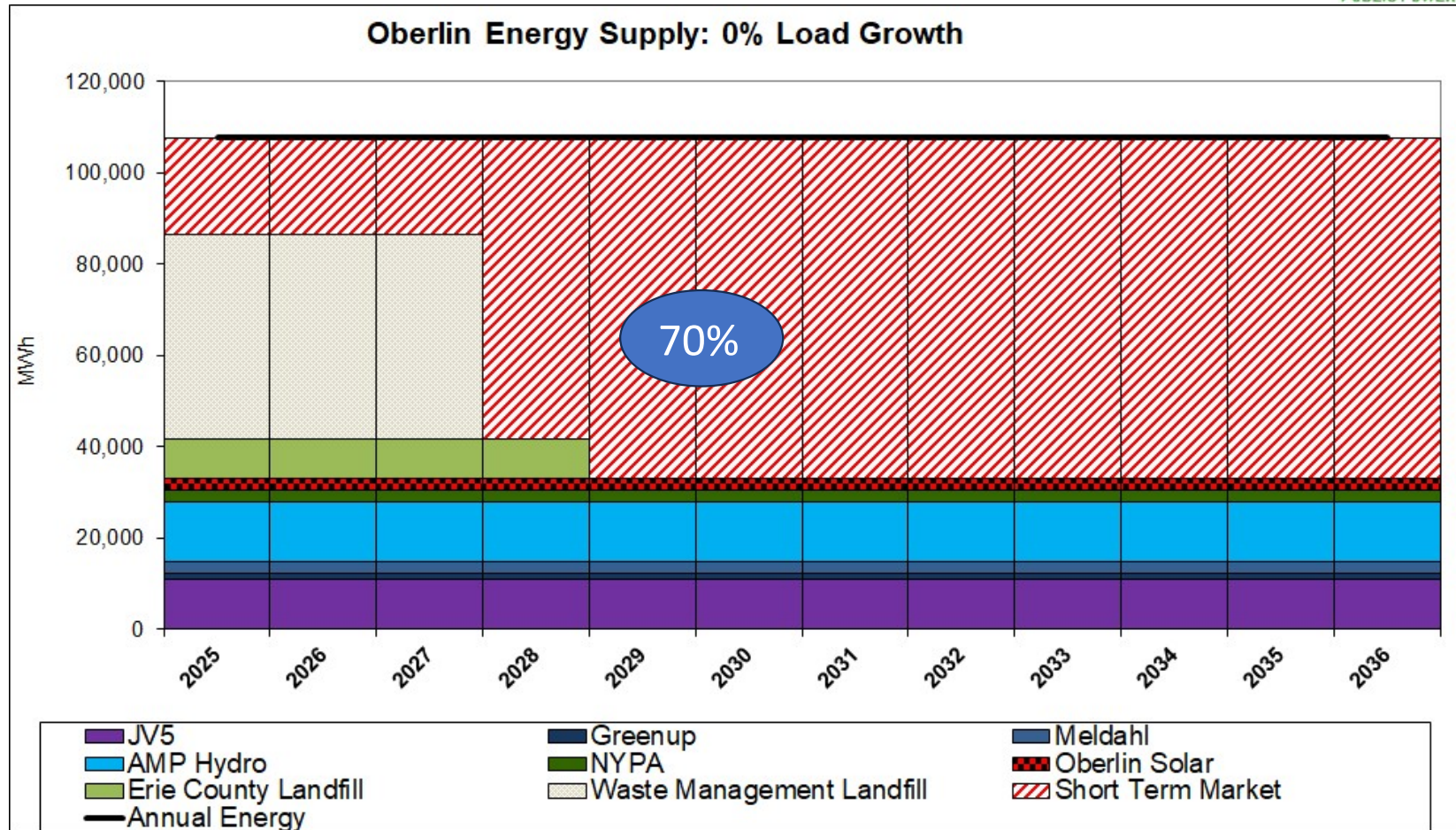

Recommended Purchase for 2027 and future

- 1.94 MW Tallgrass PPA (approximately 14% of Oberlin supply)
15-year term from January 2027 through 2042.

PPA similar to Landfill PPAs. AMP will not own the facility. We will only pay supplier for energy produced.

2027 price of \$59.50/MWh (2% per year escalation).

Approximate net rate of \$45 / MWh
After Installed Capacity and 100% of RECs
Assumes RECs sold in Ohio market

Waste Heat to Power PPAs

- Tallgrass offering two waste heat to power projects in Ohio [Chandlersville/Philo (Muskingum County) and Ashville/Columbus (Pickaway County)], totaling 22.74 MW. (AEP Zone)
 - Power from third site in Clinton County sold to University of Dayton

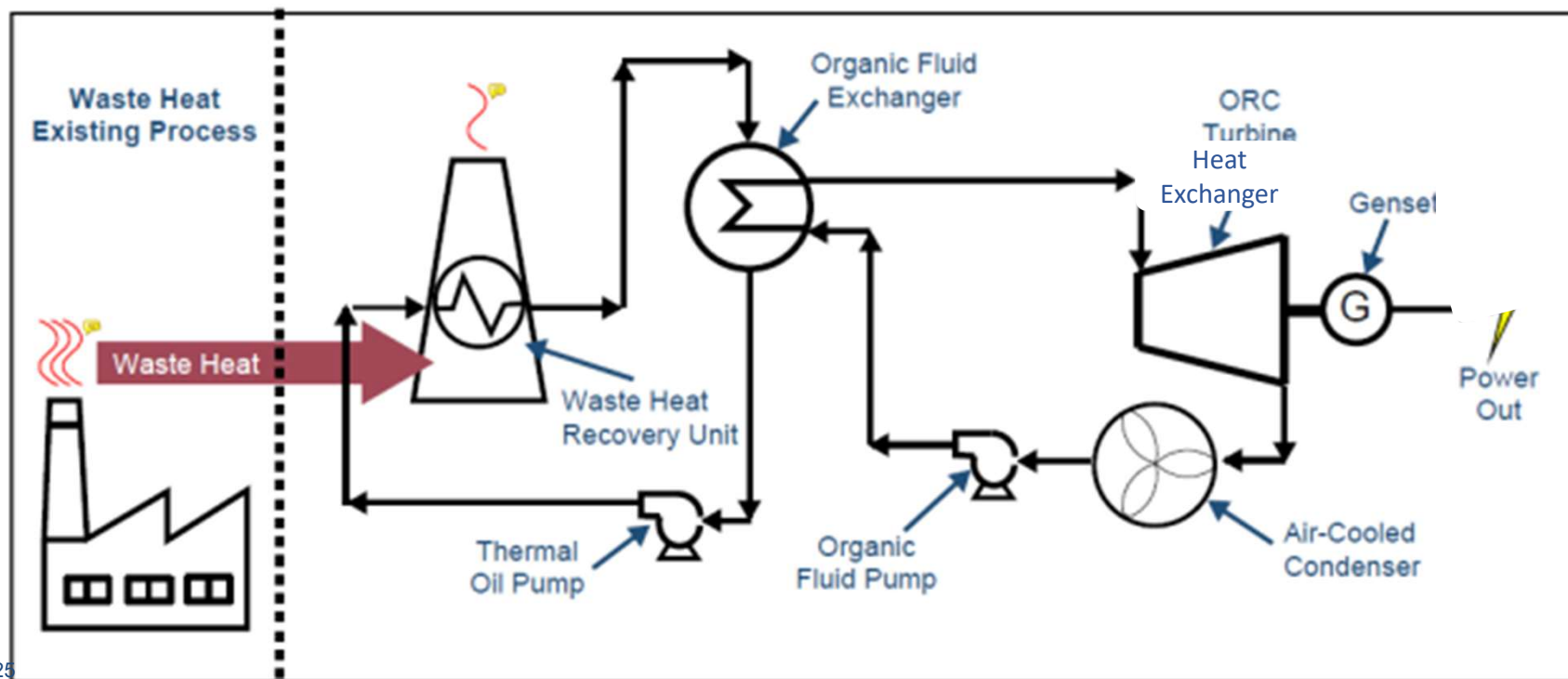

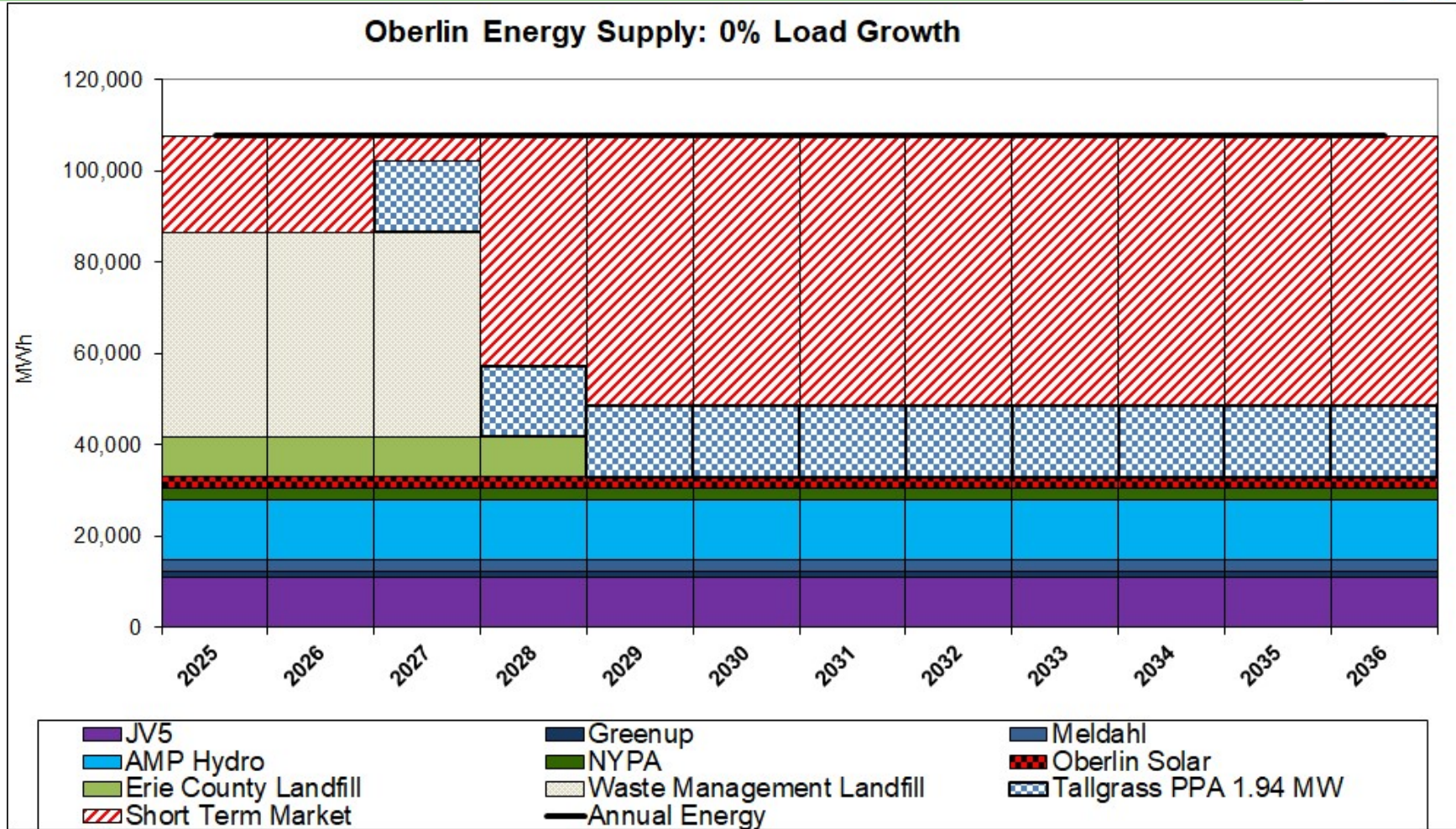

Benefits of Tallgrass PPA

- Adds to long term supply energy with renewable resource.
 - Limited amount of new renewable resources available in PJM.
- Diversifies future supply (can reduce Waste Management Landfill amount)
- Net cost is lower than current market
 - Net will be lower if RECs can be sold in other states
- Provides hedge against further increases in capacity costs

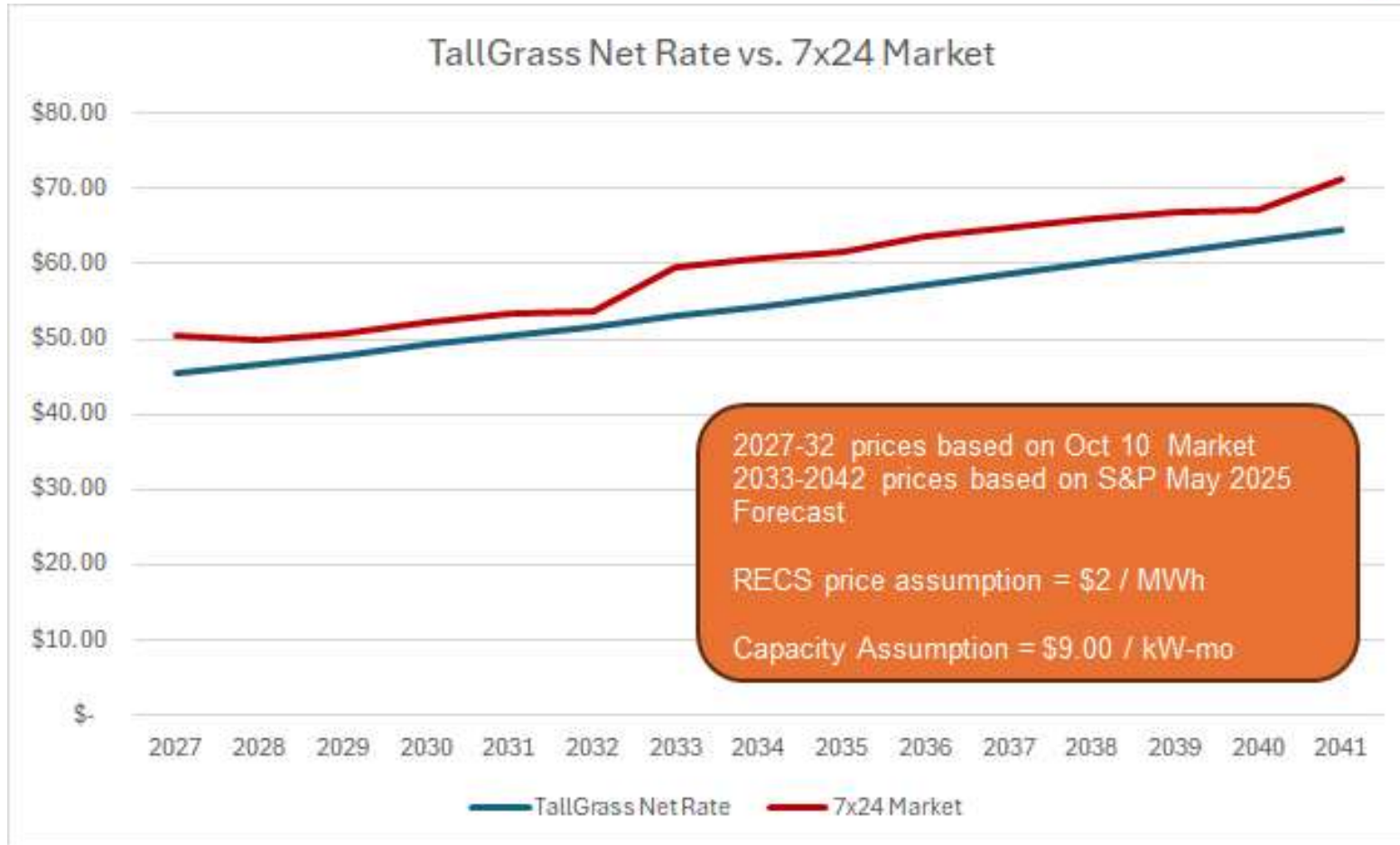

Oberlin Annual Power Rates (\$/MWh)

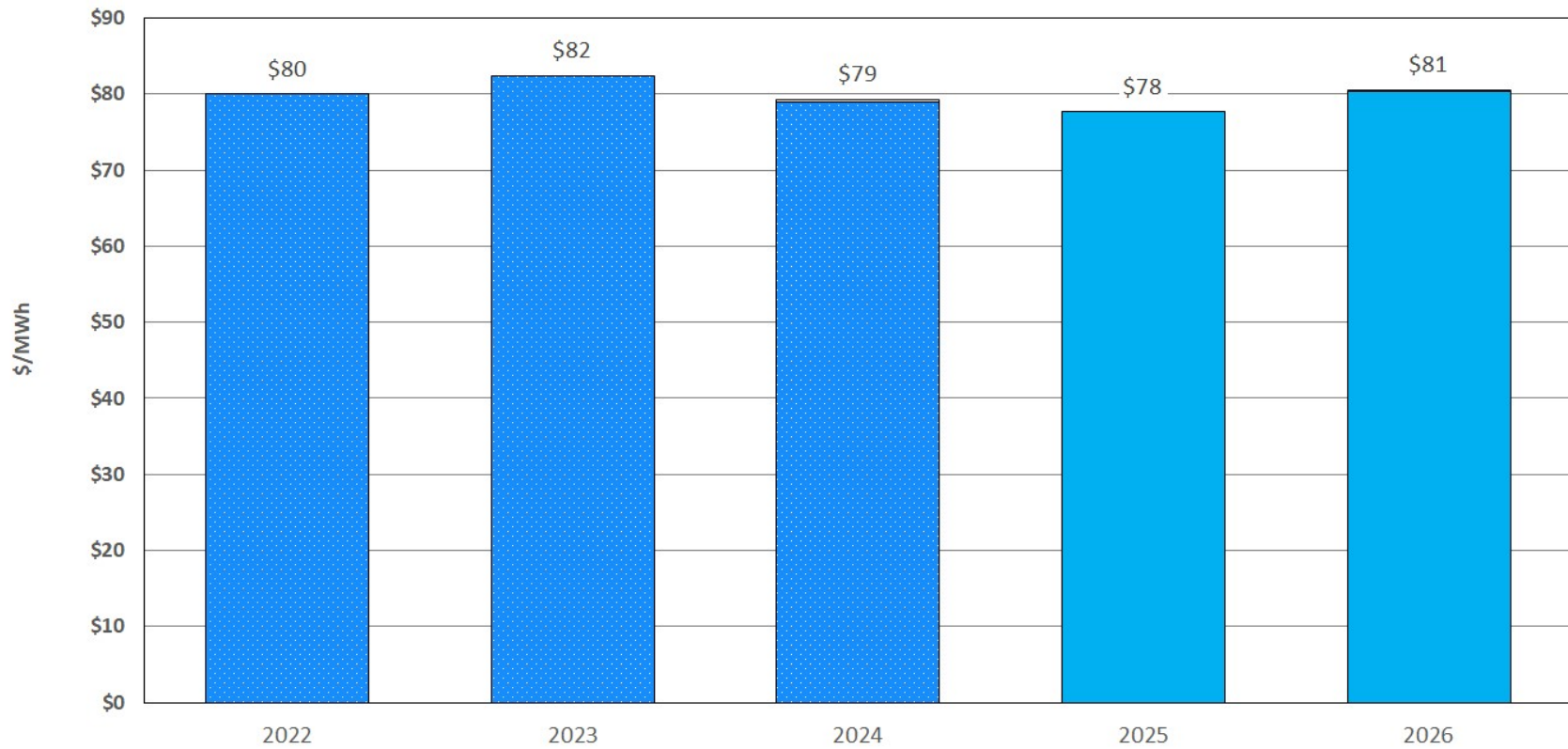

Oberlin

1,000 kWh customer pays \$145 / month
14.5 cents / kWh
 Based on past 12 mo. avg. generation charge of 9.24 cents
 ≈ 15.3 cents in 2026

	<u>2025</u>	<u>2026</u>	<u>2027</u>
Customer Charge:	\$10.00	\$12.50	\$15.00
Distribution Charge all kWh:	\$.038	\$.041	\$.044
Generation Charge:	See Generation Charge below		

The KWh Tax is applicable to all electric consumption on and after May 1, 2001. The Rates to be charged are as follows subject to automatic adjustment based on any future amendment to the Ohio Revised Code.

For a consumption period of 30 days the KWh Tax is the sum of the following:

- First 2,000 kWh consumed times \$0.00465 per kWh
- Next 13,000 kWh consumed times \$0.00419 per kWh
- Over 15,000 kWh consumed times \$0.00363 per kWh

Excise (kWh) Tax Adjustment

FE Ohio Edison Retail Rate

- Base rate approximately 9.0 cents / kWh
 - Transmission / Distribution Costs
- Generation rate for Jun 25 – May 26 = 8.2 cents / kWh

- Total FE Ohio Edison residential rate
 - **2025/2026 – 17.2 cents / kWh (Average)**

Contacts

- Mike Migliore – VP Power Supply
 - mmigliore@amppartners.org
 - 614-540-0921
- Craig Kleinhenz – Asst. VP of Power Supply Planning
 - ckleinhenz@amppartners.org
 - 614-623-7553
- Charlie Cicci - Power Supply Analyst
 - ccicci@amppartners.org
 - 614-540-1016
- Isabelle Wolford – Power Supply Analyst
 - iwolford@amppartners.org
 - 614-540-0920
- Jerry Willman – VP Energy Marketing
 - jwillman@amppartners.org
 - 614-540-6419

Waste Heat to Power Overview

- Tallgrass, owner of the Rockies Express Pipeline (REX) is developing power projects that convert waste heat at REX compressor stations to baseload, emissions free power.
- The projects utilize a process similar to a combined cycle plant, which is a proven technology to utilize otherwise waste heat into useful electric energy



Tallgrass Locations

Business Confidential - Distribution & Public Record



- 9.84 MW Located in Muskingum County, Ohio
 - Connected to Guernsey-Muskingum 12kV distribution with wheeling agreement to deliver to AMP in AEP Zone
- 12.9 MW Located in Pickaway County, Ohio
 - Connected to South Central Power 69kV distribution with wheeling agreement to deliver to AMP in AEP Zone

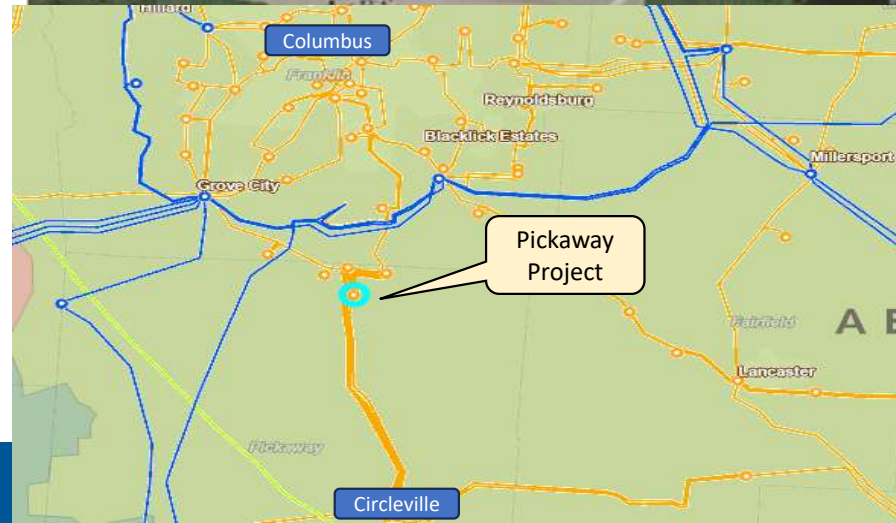
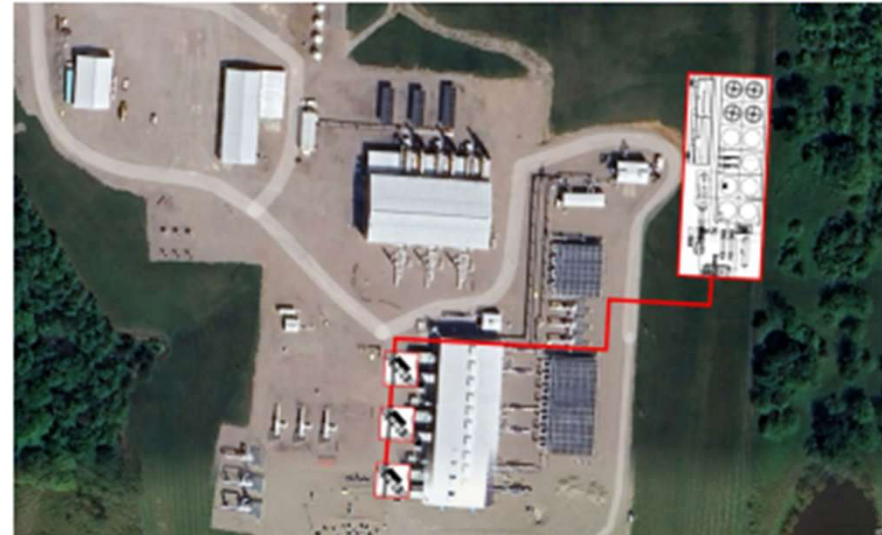

City of Oberlin Power Supply Update

October 14, 2025

Mike Migliore - VP of Power
Supply Planning



Oberlin Monthly Energy Totals

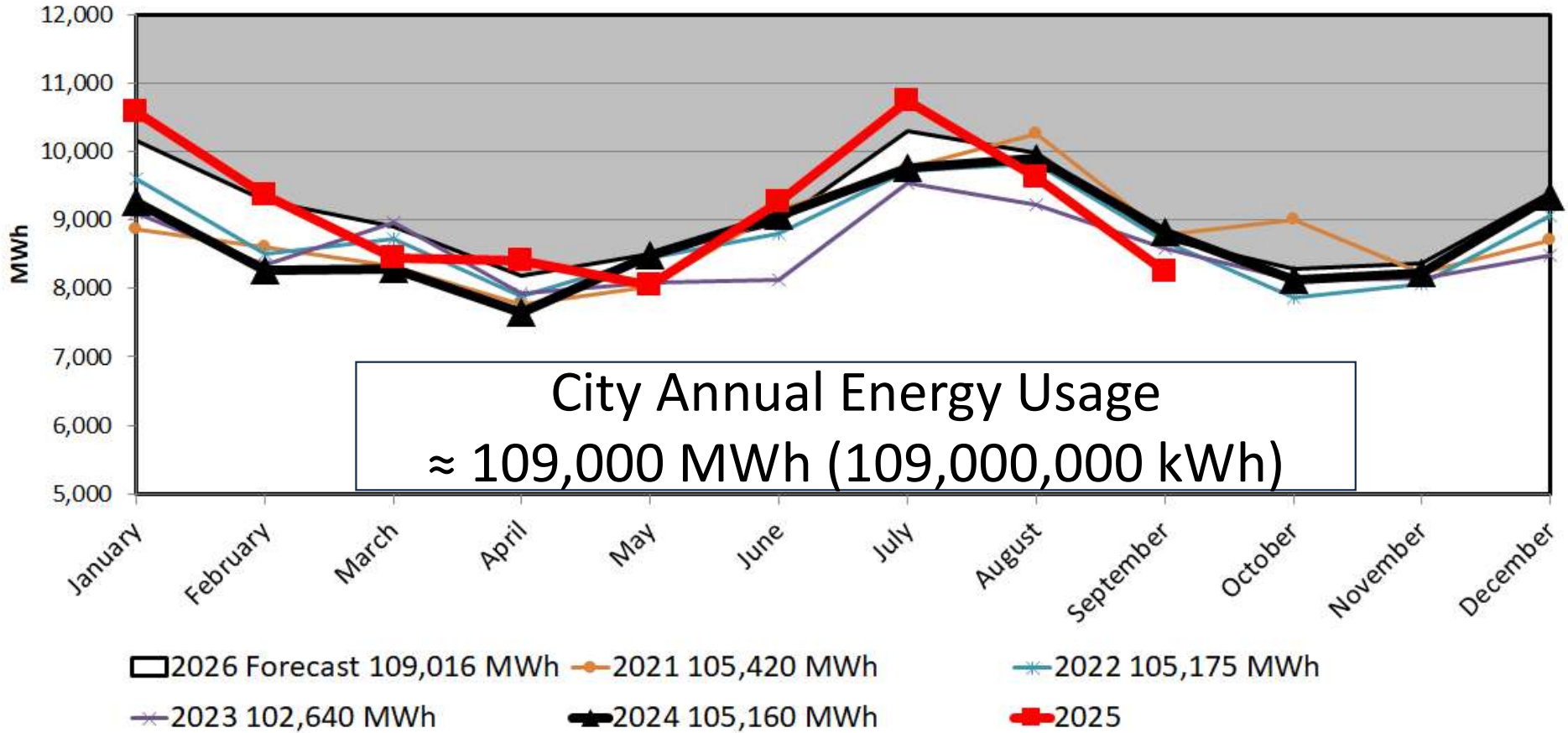

Peak Demand

Oberlin	2025	2024	2023	2022
Peak Demand (MW)	20.94	20.73	20.47	21.07
Month & Day	Jun 26	Aug 27	Sep 05	Jun 16
Hour Ending (EDT)	15	15	16	14
Temp. During Peak	89°	91°	87°	91°

Total City Peak including EDL is 26.816 MW on June 26 at 1500

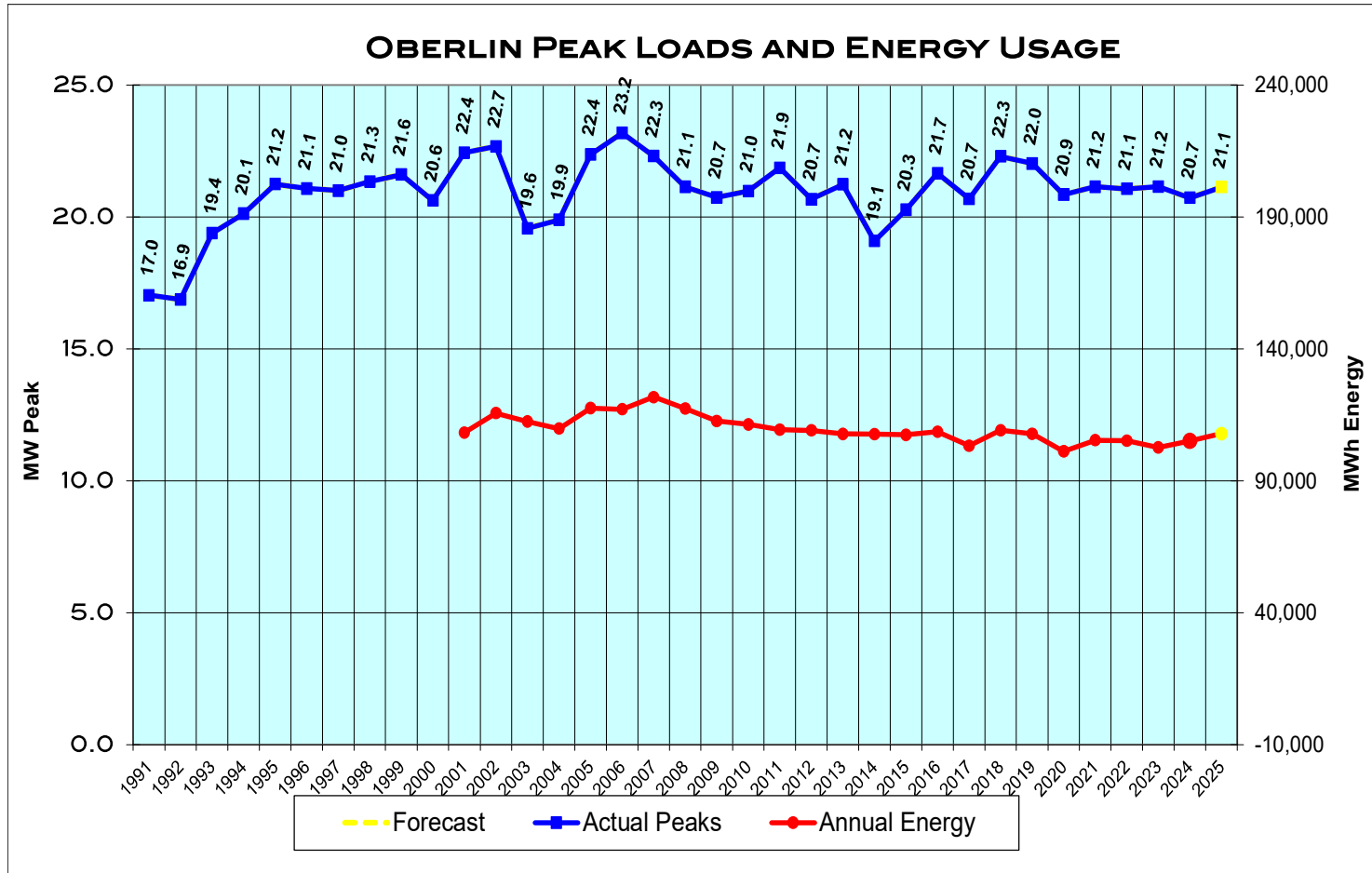



Delivery of Power (3 Types of Charges)

- Transmission
 - High Voltage (69 kV) electric lines delivering power to municipal system
 - Fixed cost (\$/ kW-mo) based on Oberlin meter at time of FirstEnergy peak (summer)
- Installed Capacity
 - Ensuring that there is enough generation in place to supply customers during period of maximum usage
 - Fixed cost (\$/ kW-mo) based on Oberlin meter at time of PJM five highest peaks (summer)
- Energy
 - Kilowatt-hours consumed by customers and produced by generators
 - Variable cost (\$ / MWh, cents / kWh)

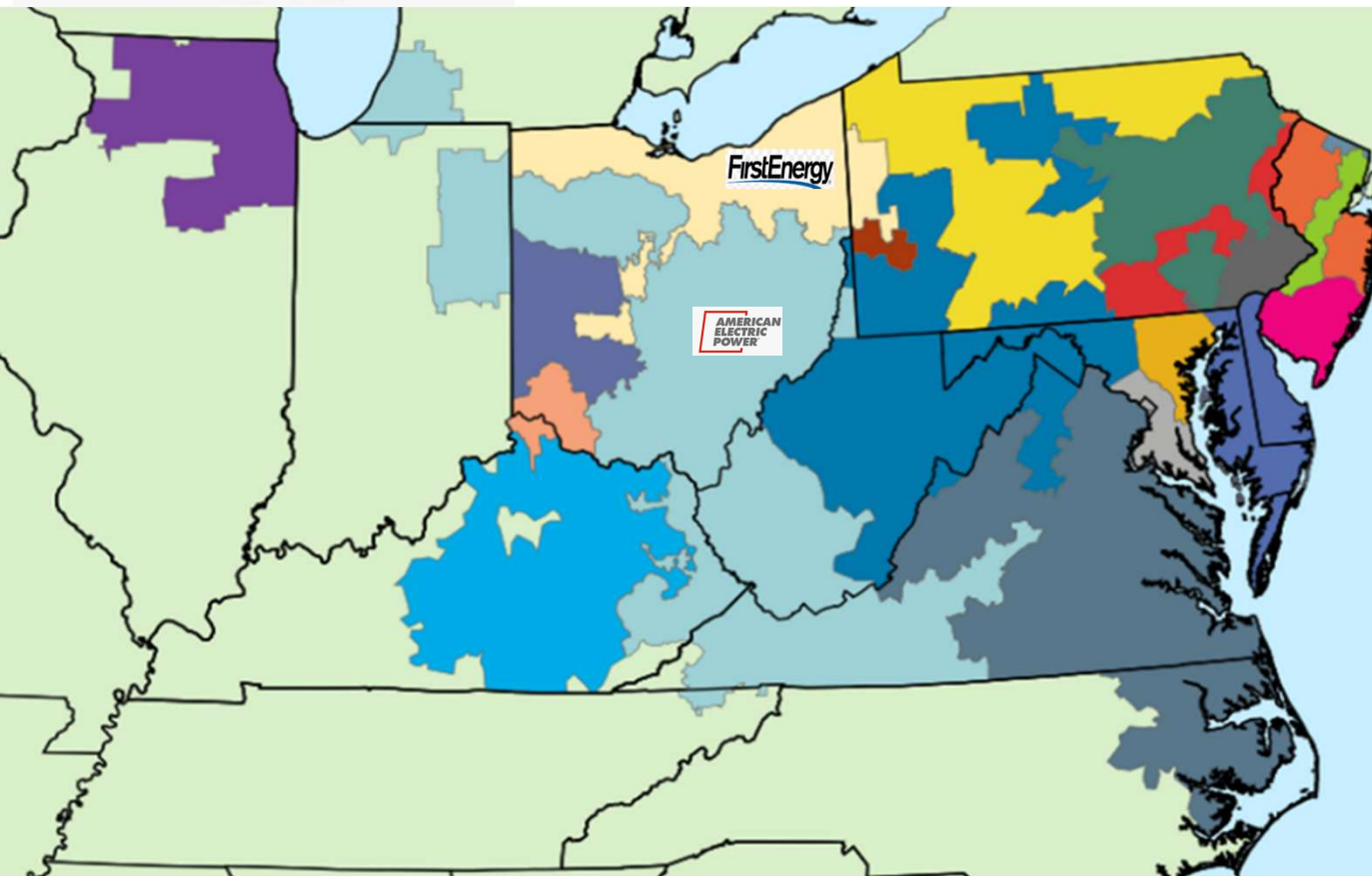

1. Economically Dispatch power plants (PJM pays generators for energy)

[hourly auction]

2. Keep the Lights on (PJM pays generators to be on call for emergency)

[annual auction]

Normal Power Flow into Oberlin

- Power metered from transmission system to municipal electric system

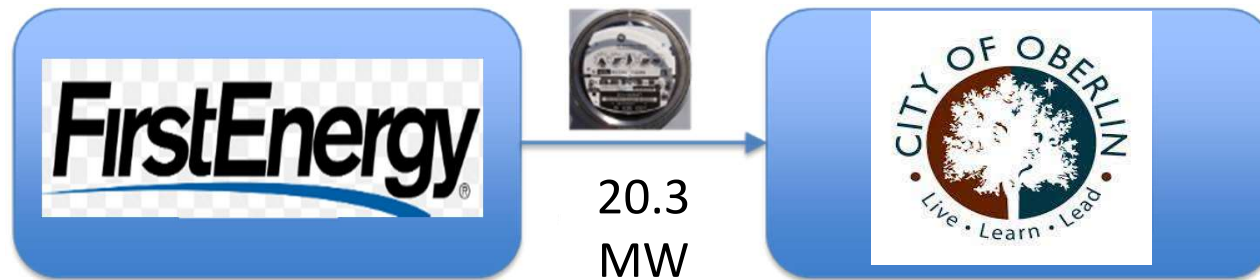

Behind the Meter Generation (BTM)

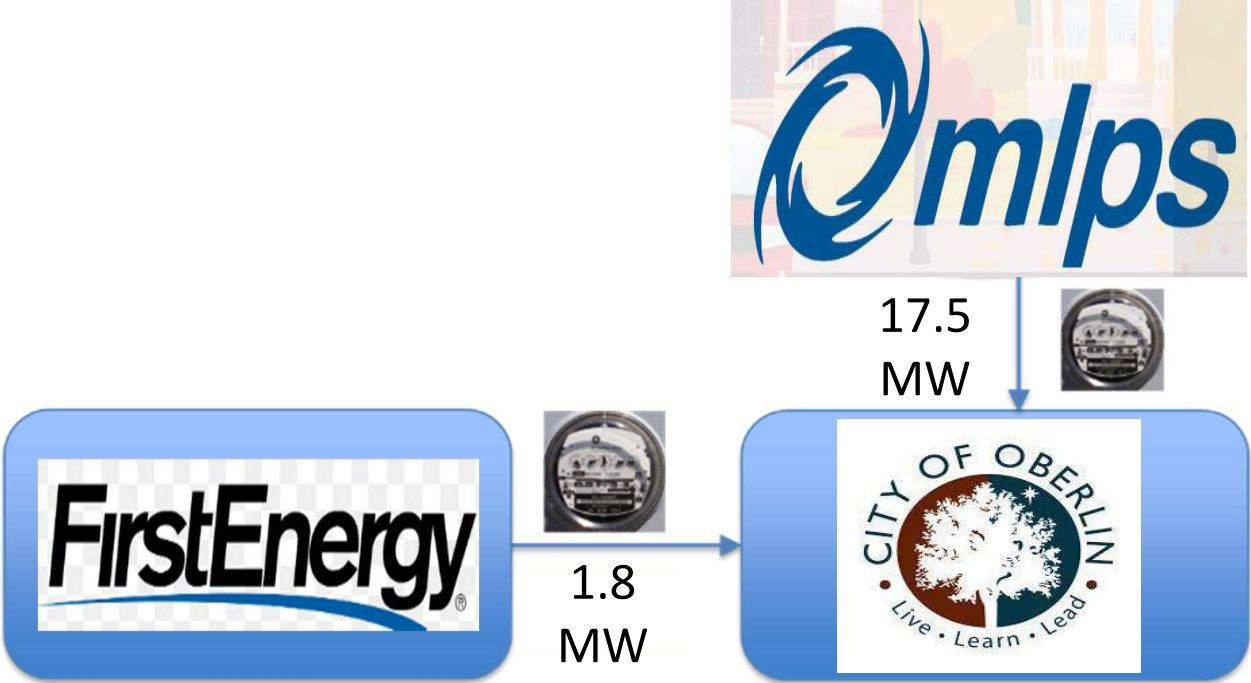

- Operation of Oberlin Power Plant saves \approx \$1.8 million per year in transmission costs (\$16 / MWh or 1.6 cents)



\$14 billion per year starting
June 2025 vs. \$2 billion in 2024

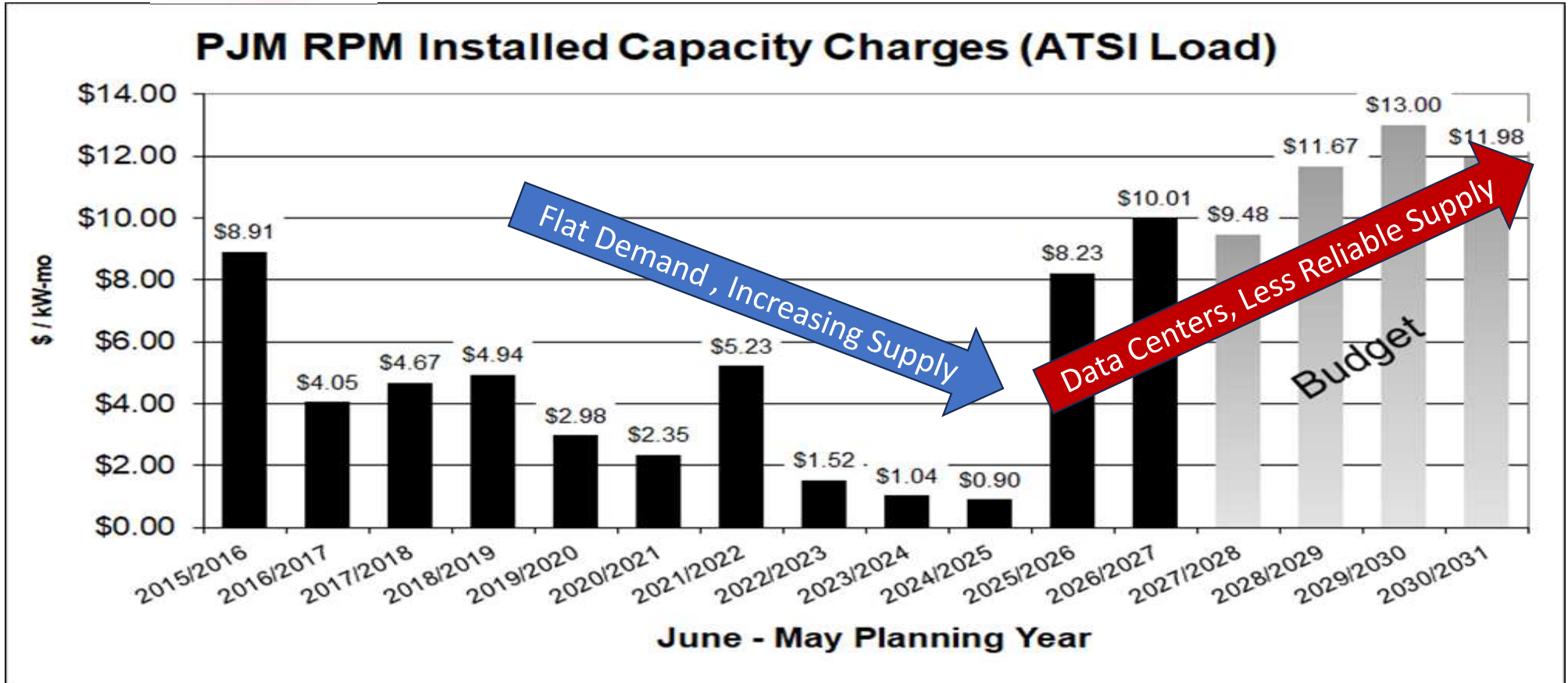

The capacity cost increase in Ohio means residential customers will see a 10-15% increase in their bills for June 2025 – May 2026, or around 2 cents per kWh. Businesses can expect an increase of up to 29%.

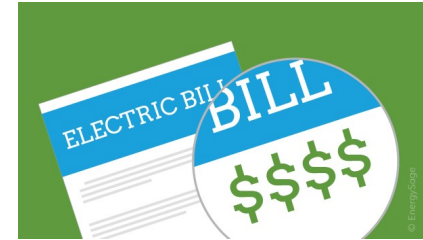

Operation of Oberlin Power Plant in summer of 2025 saved \approx \$2,000,000 per year in capacity costs (\$18 / MWh or 1.8 cents / kWh)

Total One Year Savings from Oberlin Power Plant is **\$3.8 million.** (~45 hours of operation)

Reduced Oberlin Customers' power costs by 3.4 cents / kWh

Oberlin 2025 Monthly Rates

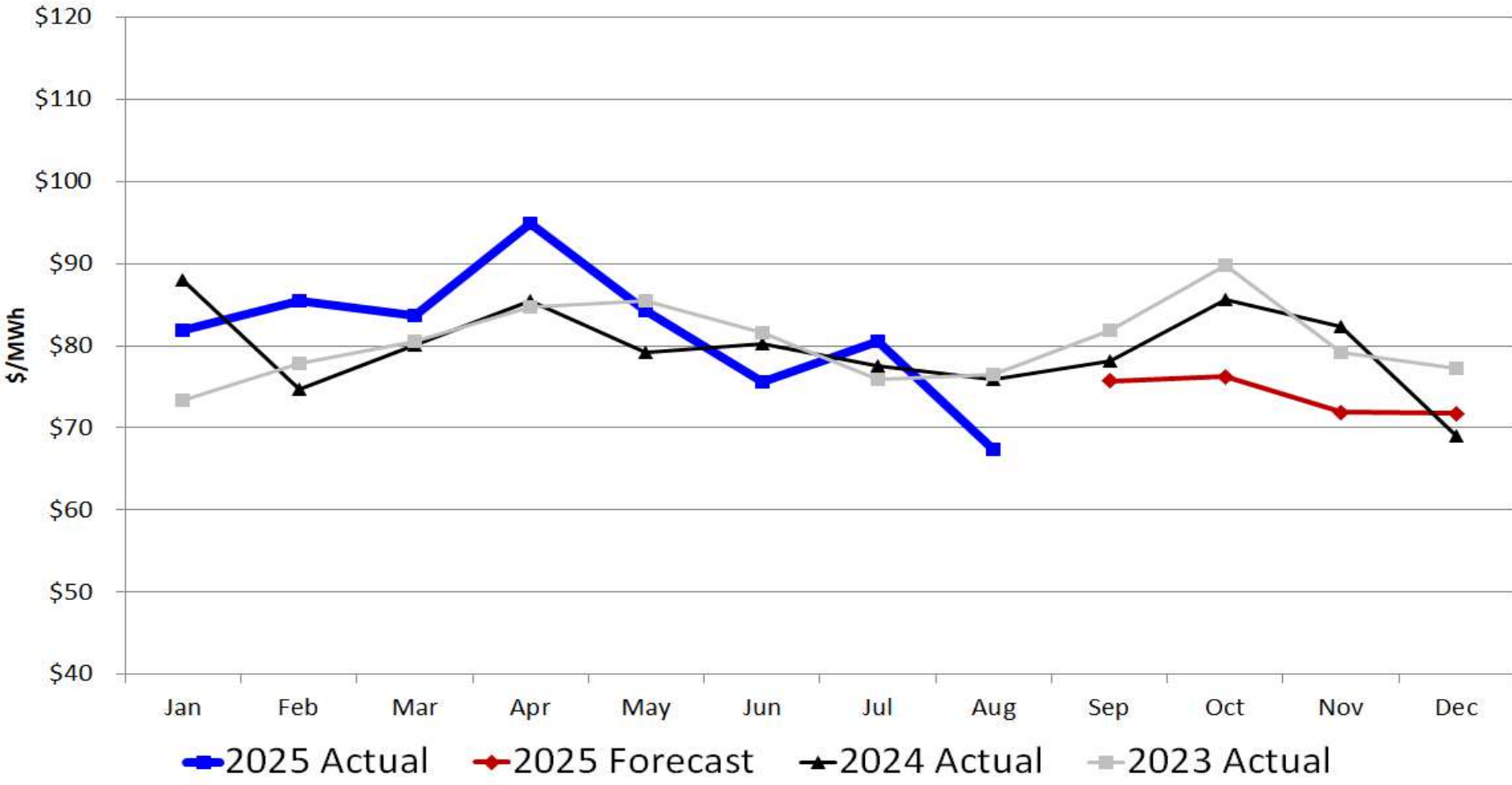

***POWER
SOURCES***



Oberlin Energy Sources

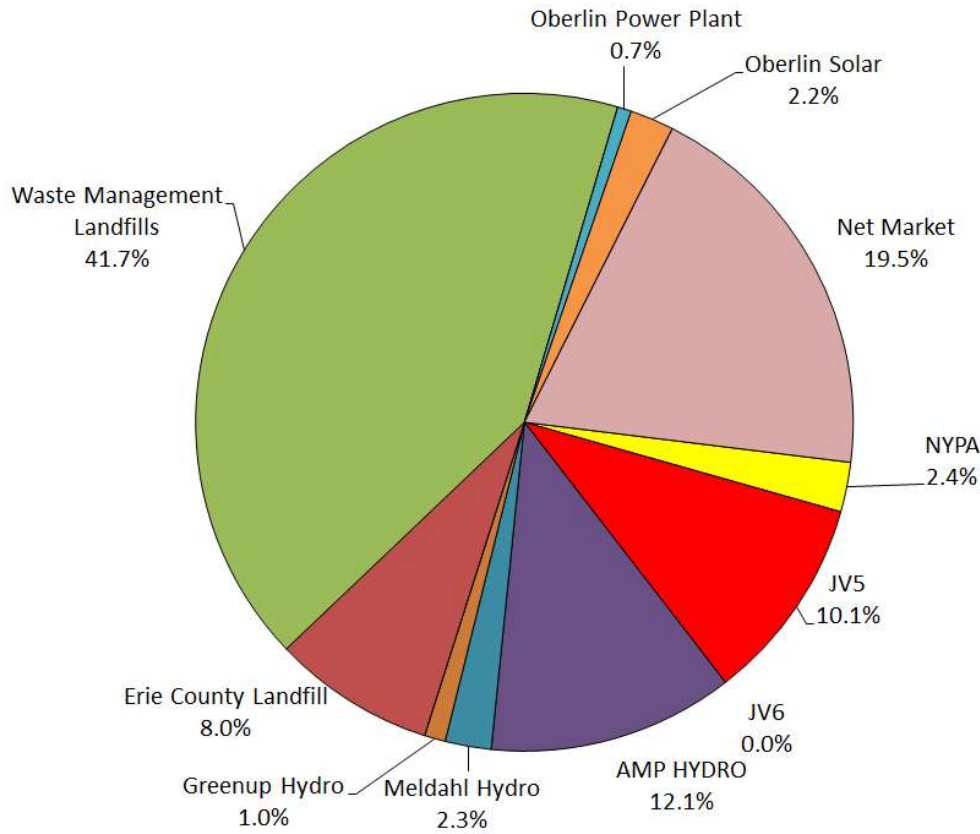

Hydro Plants and Ohio River Watershed

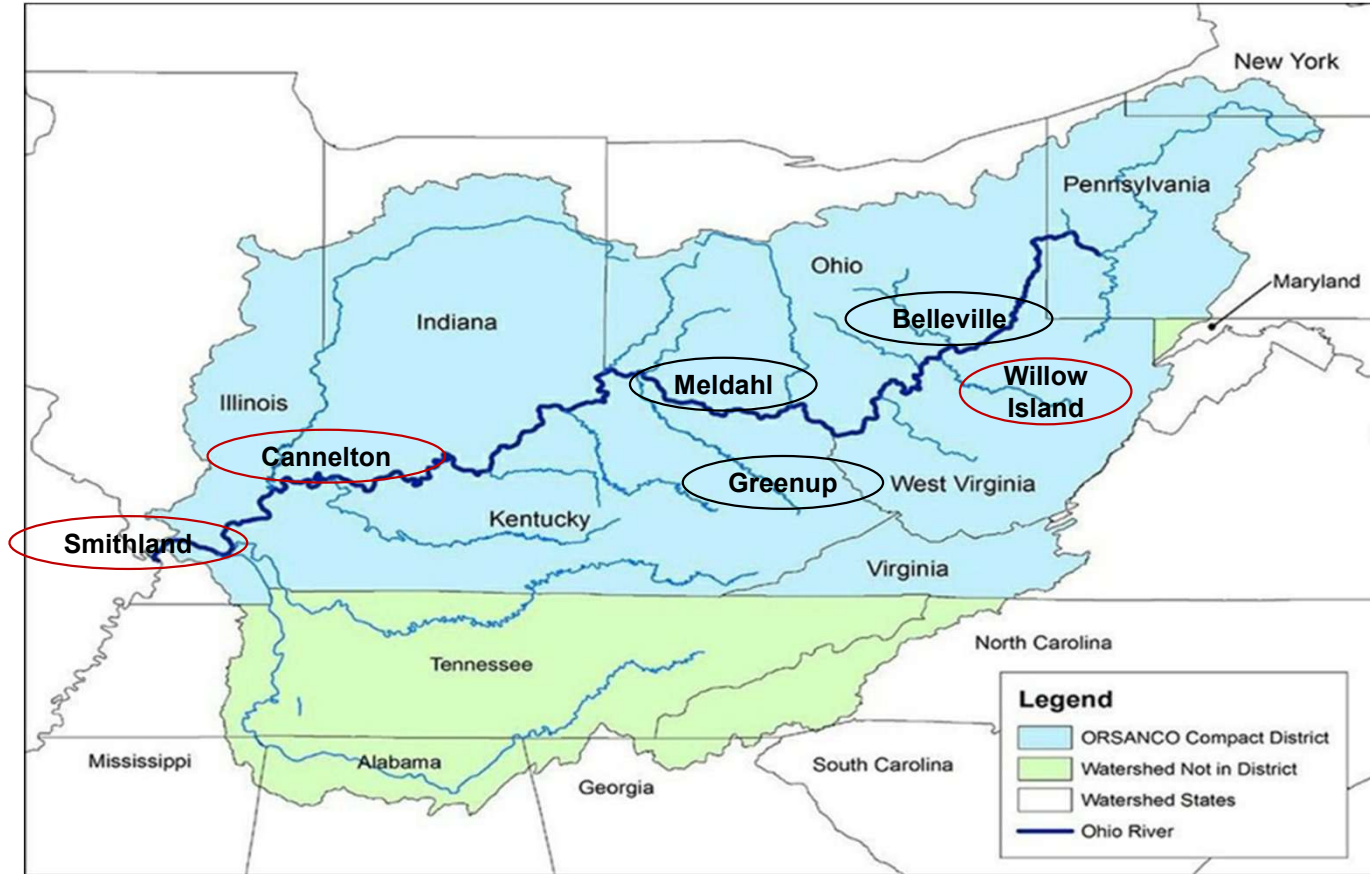

OMEGA JV5 (1,270 kW)

- 42 MW Belleville hydro project (on line 1999)
 - **Oberlin is 3.02% owner of project**
 - Debt collection through 2029
 - Approximate net rate of \$27 / MWh

NYPA (473 kW)

- New York Power Authority
- **Purchase Power Agreement**
- Current License through 2032
- Approximate net rate of \$10 / MWh



Weighted Cost of
Oberlin Hydro =
\$82 / MWh

AMP Hydro (2,598 kW)

- 208 MW project (on line 2016)
 - **Oberlin is 1.25% of project**
 - Debt collection through 2049
- Approximate net rate of \$139 / MWh

Meldahl (504 kW)

- 105 MW project (on line 2016)
 - **Oberlin is 0.48% of project**
 - Debt collection through 2049
- Approximate net rate of \$67 / MWh

Greenup (330 kW)

- 70.2 MW project (on line 1982)
 - **Oberlin is 0.47% of project**
 - Debt collection through 2045
- Approximate net rate of \$97 / MWh

Erie County Landfill (1,000 kW)

- Purchase Power Agreement through December 2028
- Located near Milan, Ohio in FirstEnergy
- Approximate net rate of \$40 / MWh
 - After Installed Capacity and 50% of RECs
 - RECs sold in Pennsylvania market



Waste Management Landfills (5,400 kW)

- Purchase Power Agreement through December 2027
- Located near Geneva, Ohio and New Springfield, Ohio (Mahoning County)
 - FirstEnergy
- Approximate net rate of \$50 / MWh
 - After Installed Capacity and 100% of RECs
 - RECs sold in Pennsylvania market



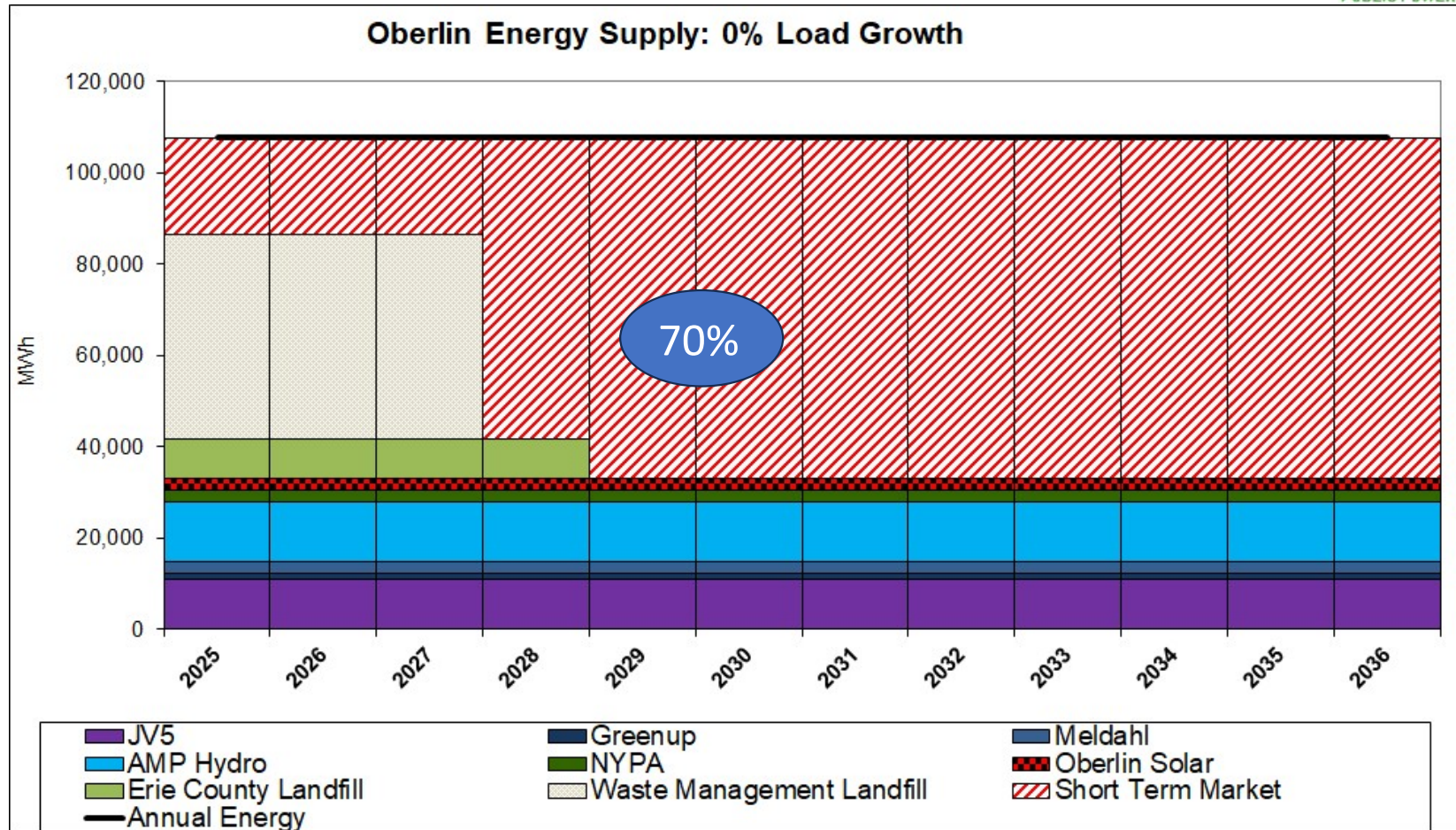

Recommended Purchase for 2027 and future

- 1.94 MW Tallgrass PPA (approximately 14% of Oberlin supply)
15-year term from January 2027 through 2042.

PPA similar to Landfill PPAs. AMP will not own the facility. We will only pay supplier for energy produced.

2027 price of \$59.50/MWh (2% per year escalation).

Approximate net rate of \$45 / MWh
After Installed Capacity and 100% of RECs
Assumes RECs sold in Ohio market

Waste Heat to Power PPAs

- Tallgrass offering two waste heat to power projects in Ohio [Chandlersville/Philo (Muskingum County) and Ashville/Columbus (Pickaway County)], totaling 22.74 MW. (AEP Zone)
 - Power from third site in Clinton County sold to University of Dayton

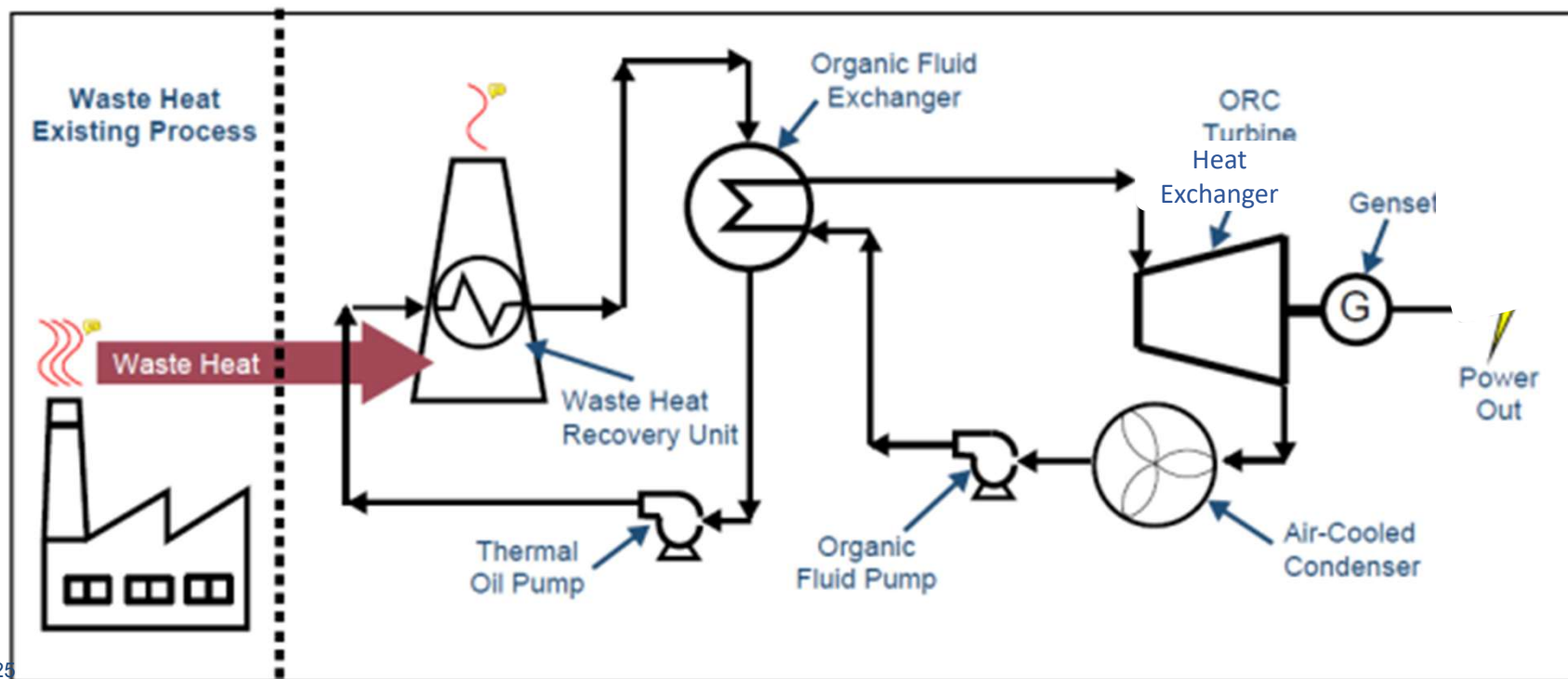

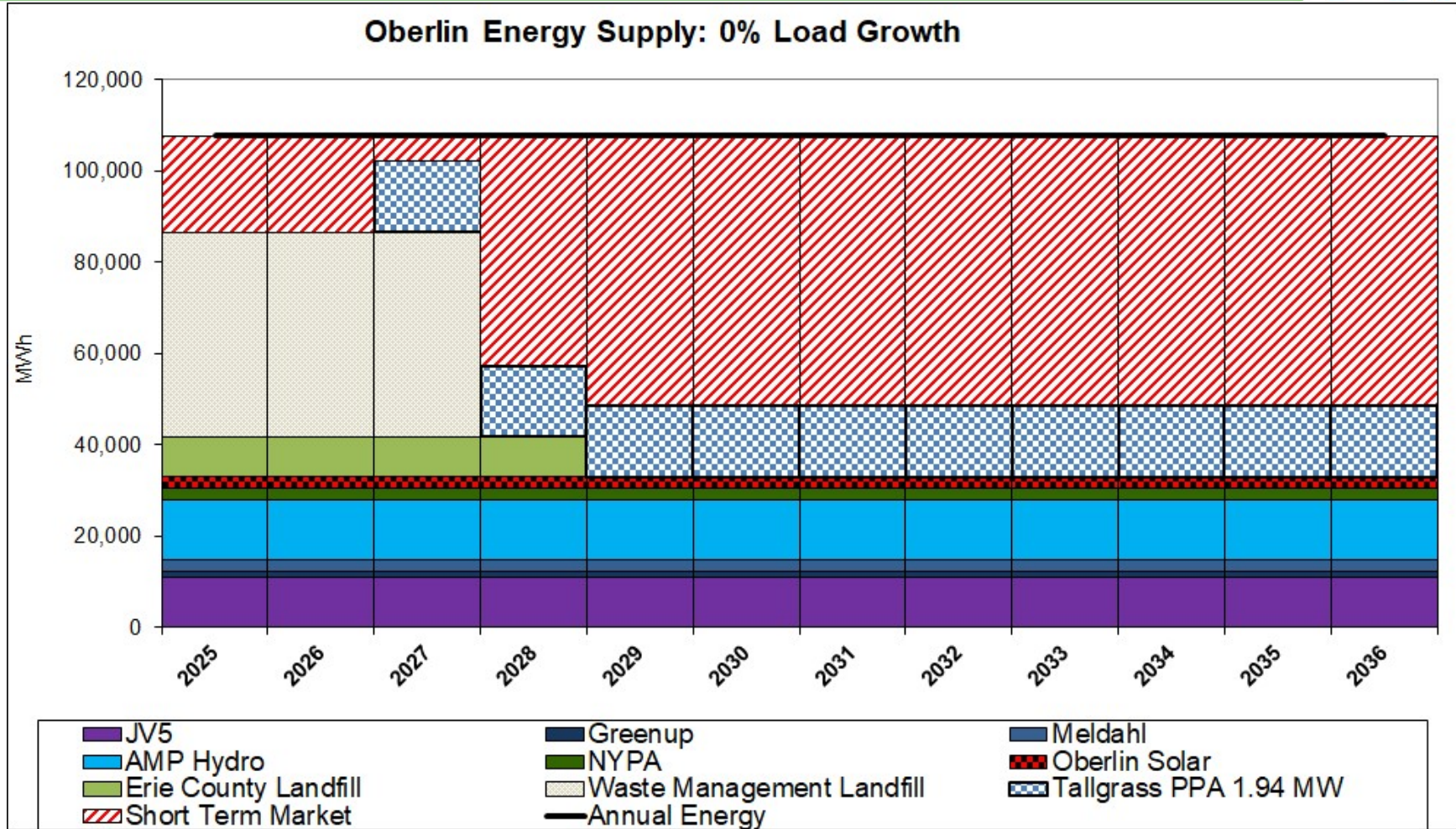

Benefits of Tallgrass PPA

- Adds to long term supply energy with renewable resource.
 - Limited amount of new renewable resources available in PJM.
- Diversifies future supply (can reduce Waste Management Landfill amount)
- Net cost is lower than current market
 - Net will be lower if RECs can be sold in other states
- Provides hedge against further increases in capacity costs

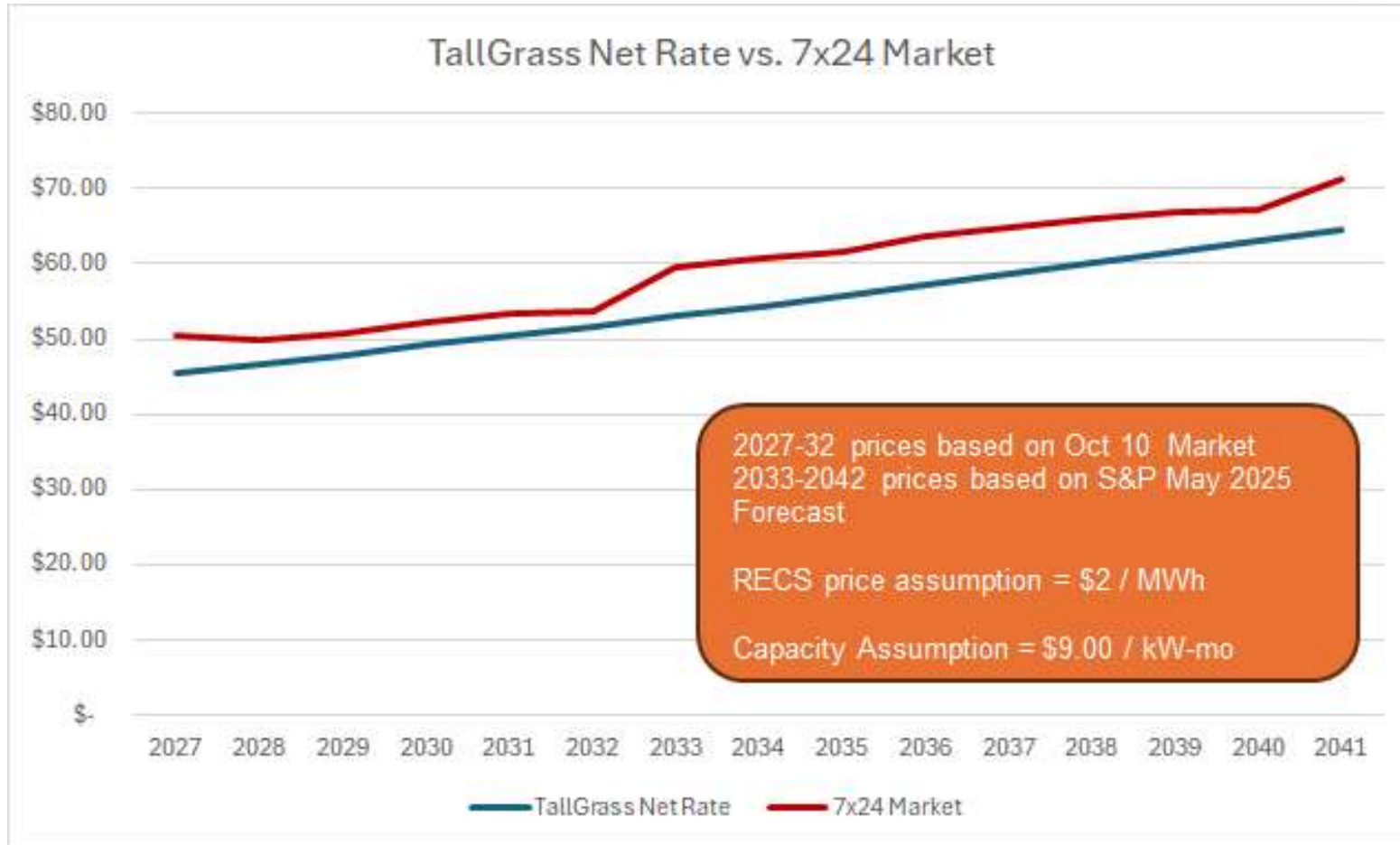

Oberlin Annual Power Rates (\$/MWh)

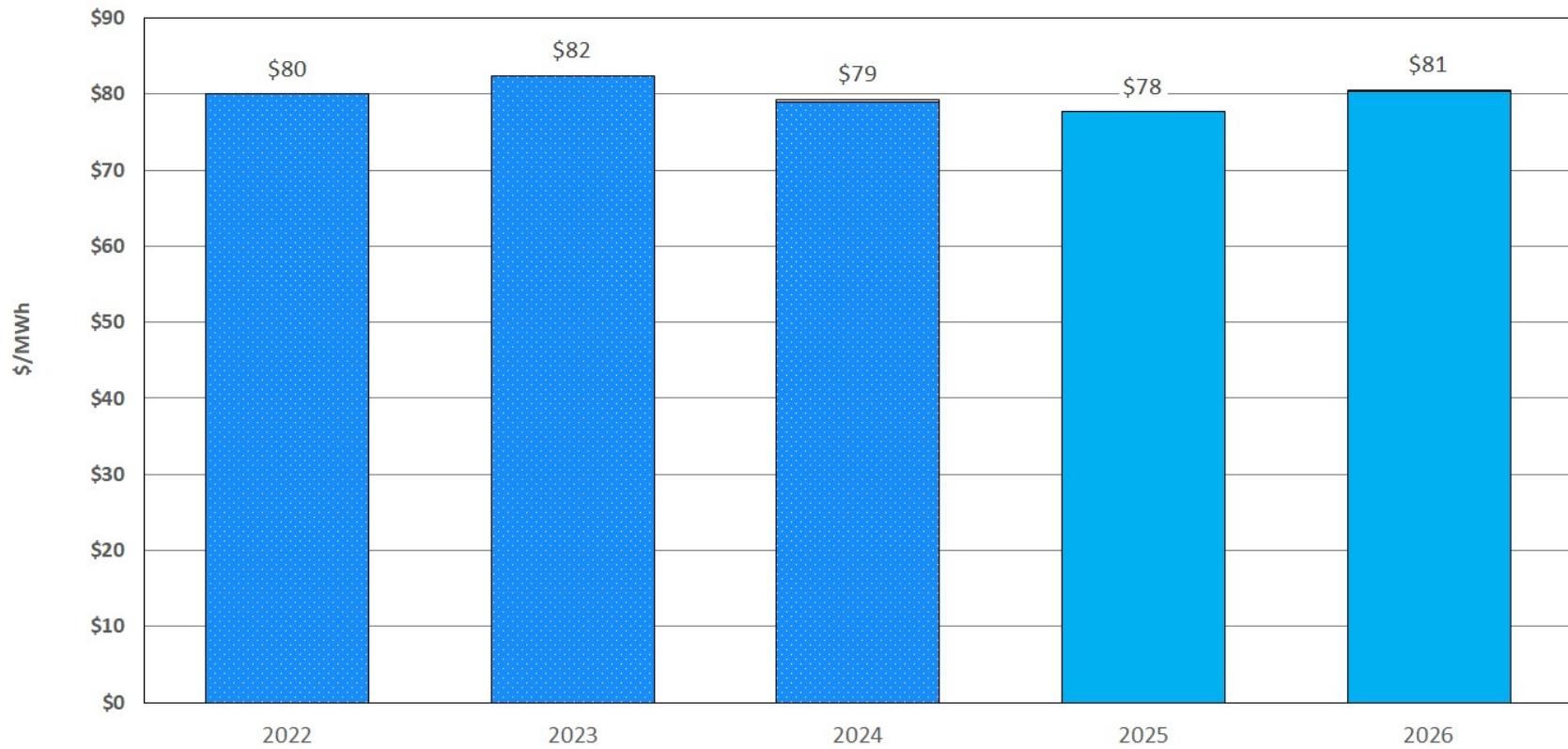

Oberlin

1,000 kWh customer pays \$145 / month
14.5 cents / kWh
Based on past 12 mo. avg. generation charge of 9.24 cents
≈ 15.3 cents in 2026

	<u>2025</u>	<u>2026</u>	<u>2027</u>
Customer Charge:	\$10.00	\$12.50	\$15.00
Distribution Charge all kWh:	\$.038	\$.041	\$.044
Generation Charge:	See Generation Charge below		

The KWh Tax is applicable to all electric consumption on and after May 1, 2001. The Rates to be charged are as follows subject to automatic adjustment based on any future amendment to the Ohio Revised Code.

For a consumption period of 30 days the KWh Tax is the sum of the following:

- First 2,000 kWh consumed times \$0.00465 per kWh
- Next 13,000 kWh consumed times \$0.00419 per kWh
- Over 15,000 kWh consumed times \$0.00363 per kWh

Excise (kWh) Tax Adjustment

FE Ohio Edison Retail Rate

- Base rate approximately 9.0 cents / kWh
 - Transmission / Distribution Costs
- Generation rate for Jun 25 – May 26 = 8.2 cents / kWh

- Total FE Ohio Edison residential rate
 - **2025/2026 – 17.2 cents / kWh (Average)**

Contacts

- Mike Migliore – VP Power Supply
 - mmigliore@amppartners.org
 - 614-540-0921
- Craig Kleinhenz – Asst. VP of Power Supply Planning
 - ckleinhenz@amppartners.org
 - 614-623-7553
- Charlie Cicci - Power Supply Analyst
 - ccicci@amppartners.org
 - 614-540-1016
- Isabelle Wolford – Power Supply Analyst
 - iwolford@amppartners.org
 - 614-540-0920
- Jerry Willman – VP Energy Marketing
 - jwillman@amppartners.org
 - 614-540-6419

Waste Heat to Power Overview

- Tallgrass, owner of the Rockies Express Pipeline (REX) is developing power projects that convert waste heat at REX compressor stations to baseload, emissions free power.
- The projects utilize a process similar to a combined cycle plant, which is a proven technology to utilize otherwise waste heat into useful electric energy



Tallgrass Locations

Business Confidential - Distribution & Public Record



- 9.84 MW Located in Muskingum County, Ohio
 - Connected to Guernsey-Muskingum 12kV distribution with wheeling agreement to deliver to AMP in AEP Zone
- 12.9 MW Located in Pickaway County, Ohio
 - Connected to South Central Power 69kV distribution with wheeling agreement to deliver to AMP in AEP Zone

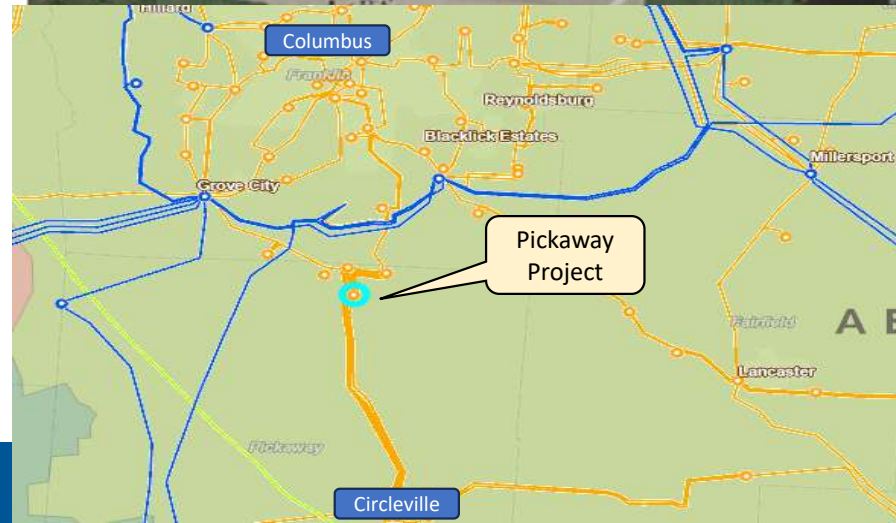

City of Oberlin Power Supply Update

October 14, 2025

Mike Migliore - VP of Power
Supply Planning



Oberlin Monthly Energy Totals

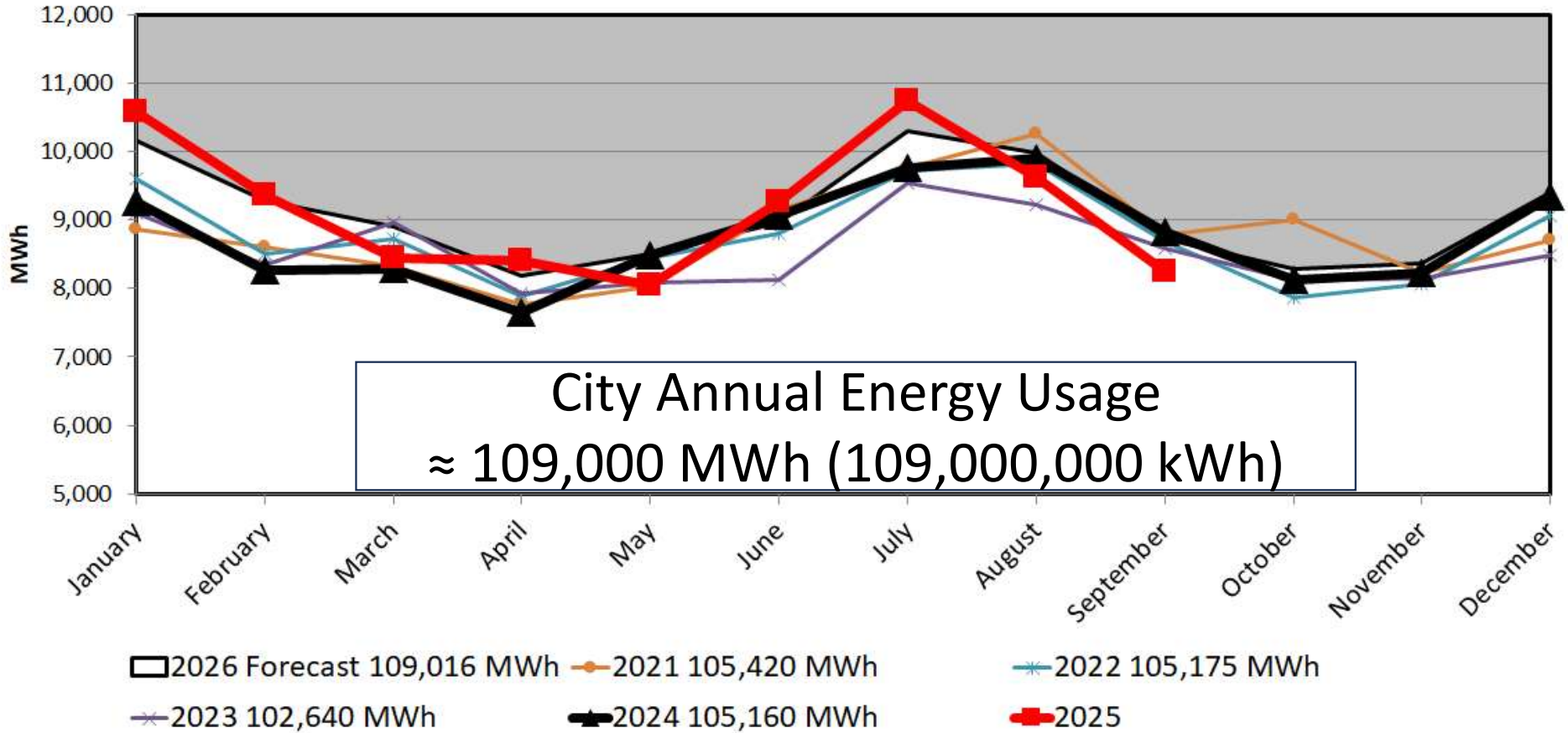

Peak Demand

Oberlin	2025	2024	2023	2022
Peak Demand (MW)	20.94	20.73	20.47	21.07
Month & Day	Jun 26	Aug 27	Sep 05	Jun 16
Hour Ending (EDT)	15	15	16	14
Temp. During Peak	89°	91°	87°	91°

Total City Peak including EDL is 26.816 MW on June 26 at 1500

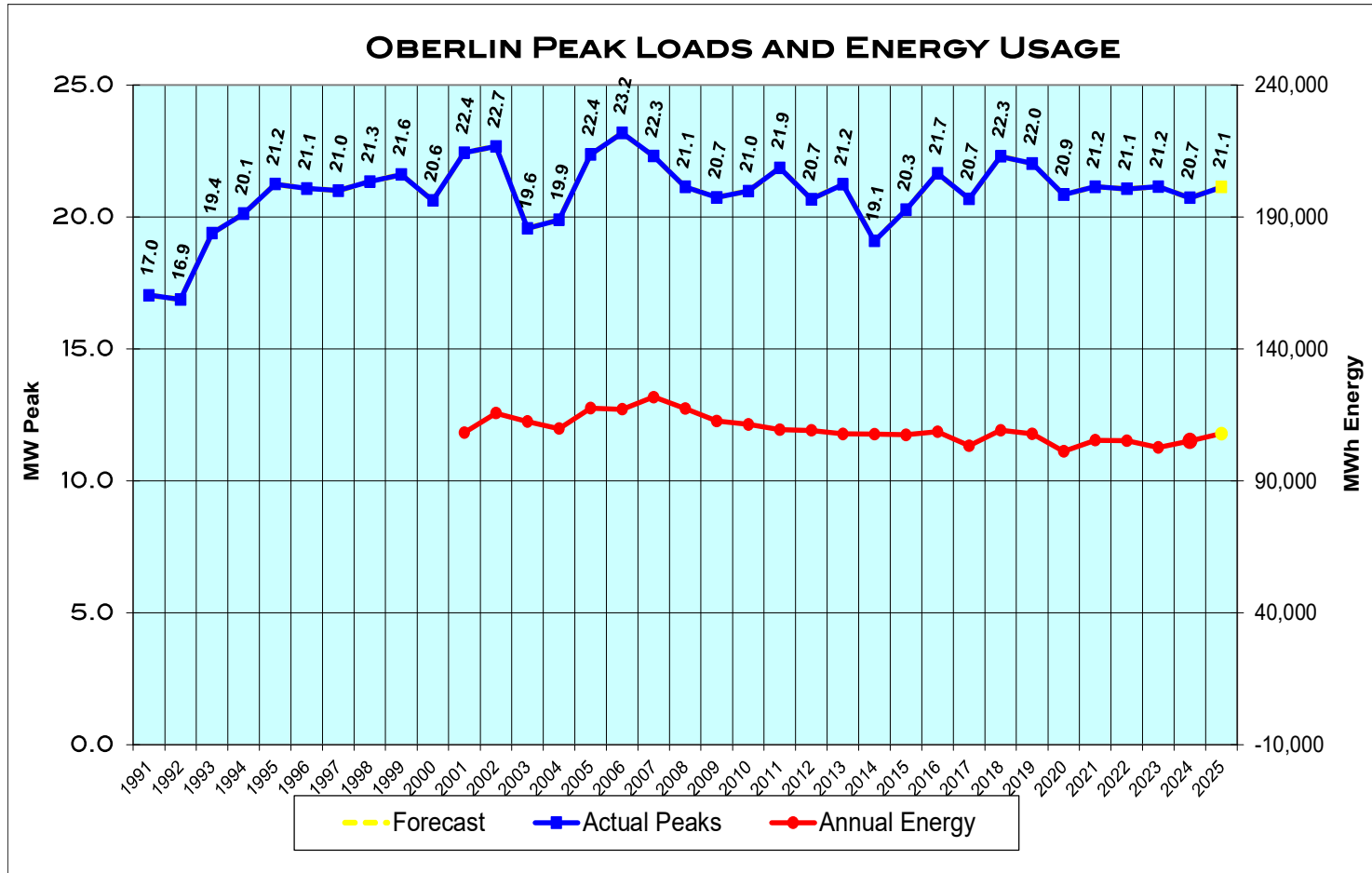



Delivery of Power (3 Types of Charges)

- Transmission
 - High Voltage (69 kV) electric lines delivering power to municipal system
 - Fixed cost (\$/ kW-mo) based on Oberlin meter at time of FirstEnergy peak (summer)
- Installed Capacity
 - Ensuring that there is enough generation in place to supply customers during period of maximum usage
 - Fixed cost (\$/ kW-mo) based on Oberlin meter at time of PJM five highest peaks (summer)
- Energy
 - Kilowatt-hours consumed by customers and produced by generators
 - Variable cost (\$ / MWh, cents / kWh)

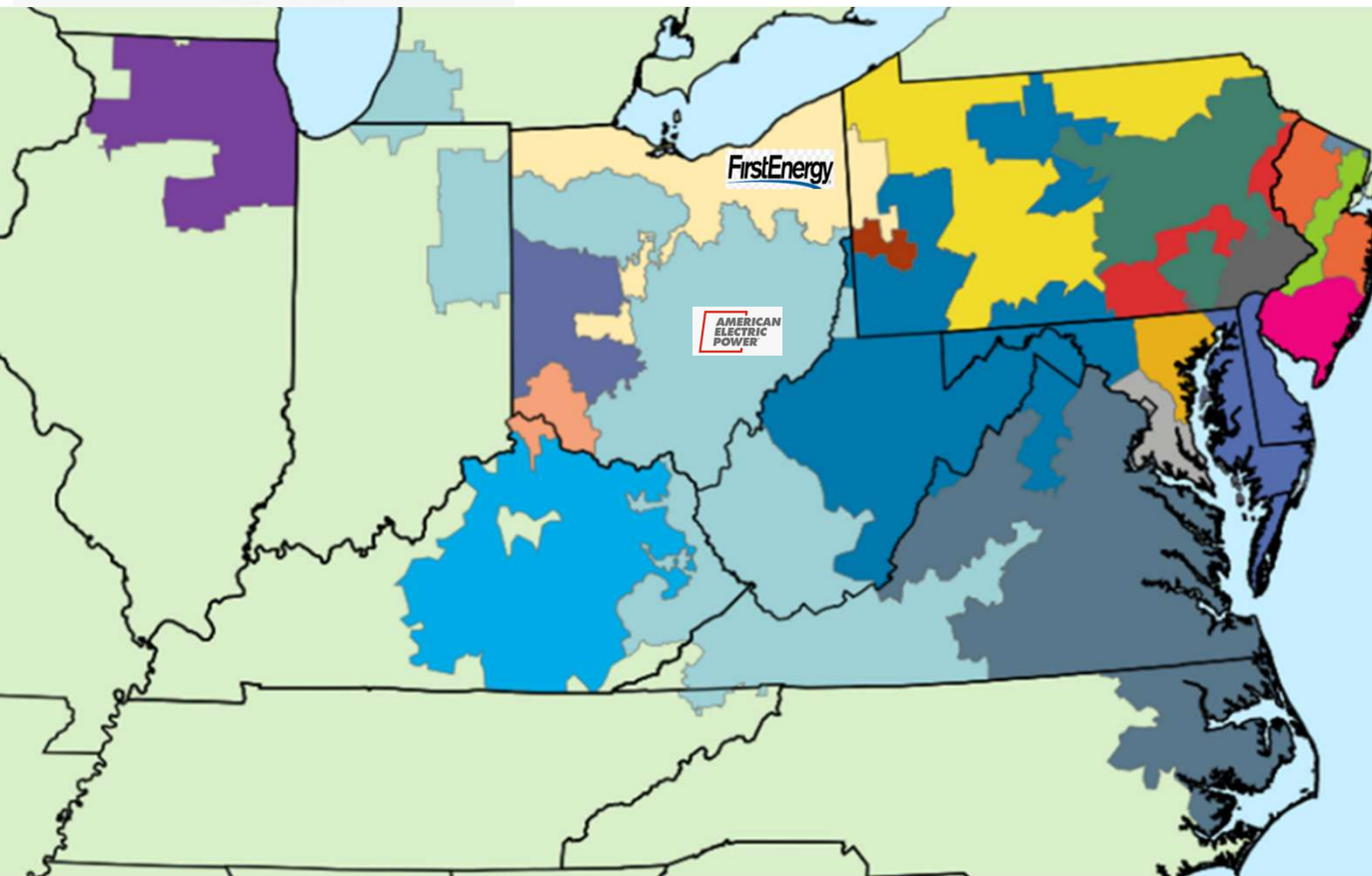

1. Economically Dispatch power plants (PJM pays generators for energy)

[hourly auction]

2. Keep the Lights on (PJM pays generators to be on call for emergency)

[annual auction]

Normal Power Flow into Oberlin

- Power metered from transmission system to municipal electric system

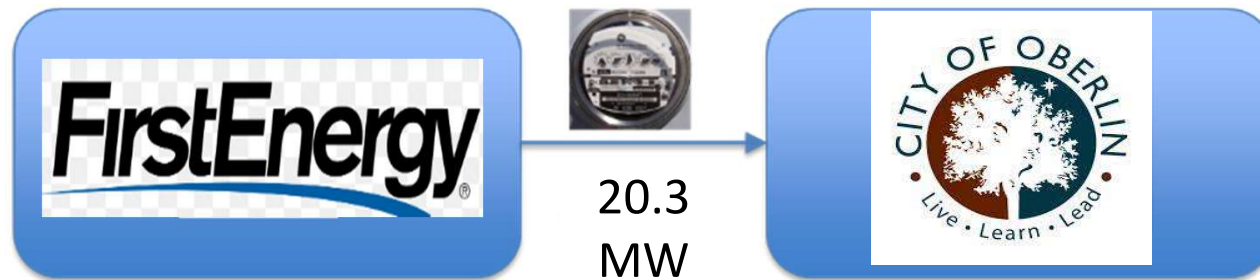

Behind the Meter Generation (BTM)

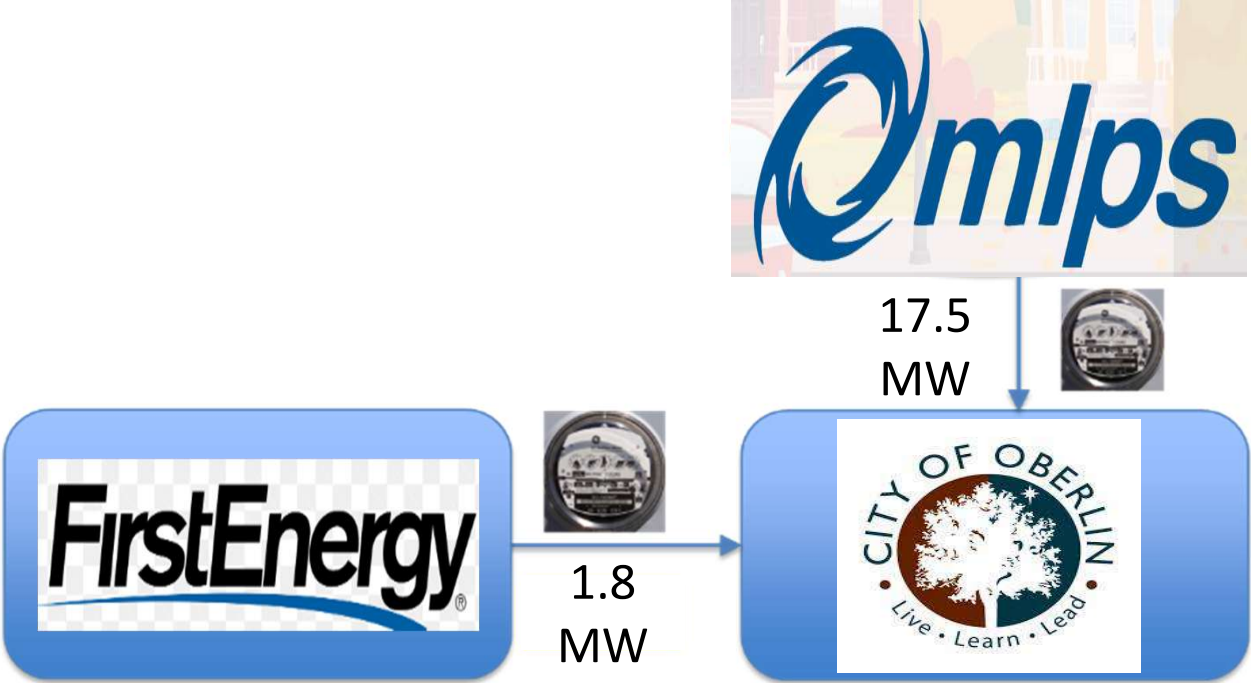

- Operation of Oberlin Power Plant saves \approx \$1.8 million per year in transmission costs (\$16 / MWh or 1.6 cents)



\$14 billion per year starting June 2025 vs. \$2 billion in 2024

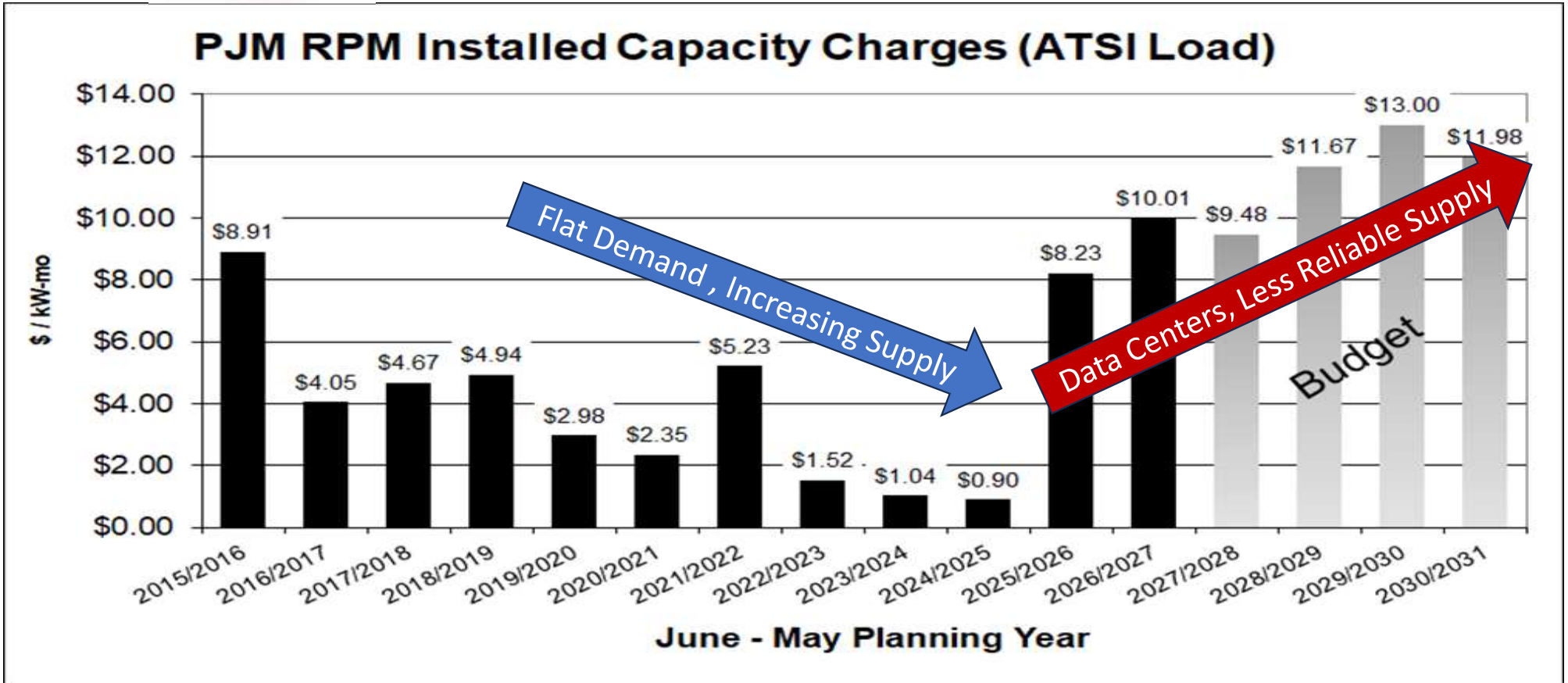

The capacity cost increase in Ohio means residential customers will see a 10-15% increase in their bills for June 2025 – May 2026, or around 2 cents per kWh. Businesses can expect an increase of up to 29%.

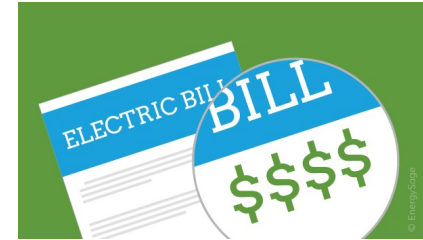

Operation of Oberlin Power Plant in summer of 2025 saved \approx \$2,000,000 per year in capacity costs (\$18 / MWh or 1.8 cents / kWh)

Total One Year Savings from Oberlin Power Plant is **\$3.8 million.** (~45 hours of operation)

Reduced Oberlin Customers' power costs by 3.4 cents / kWh

Oberlin 2025 Monthly Rates

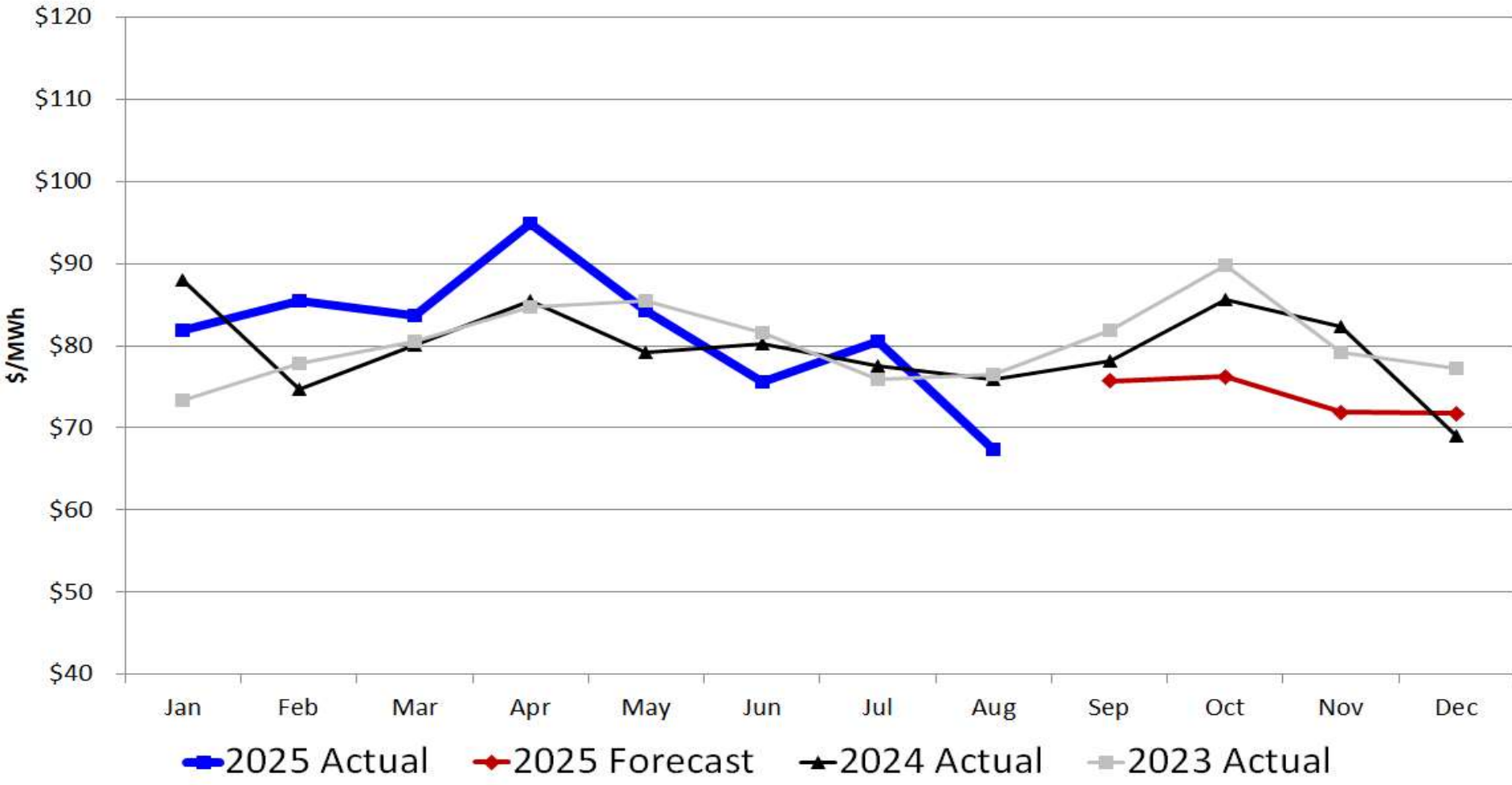

***POWER
SOURCES***



Oberlin Energy Sources

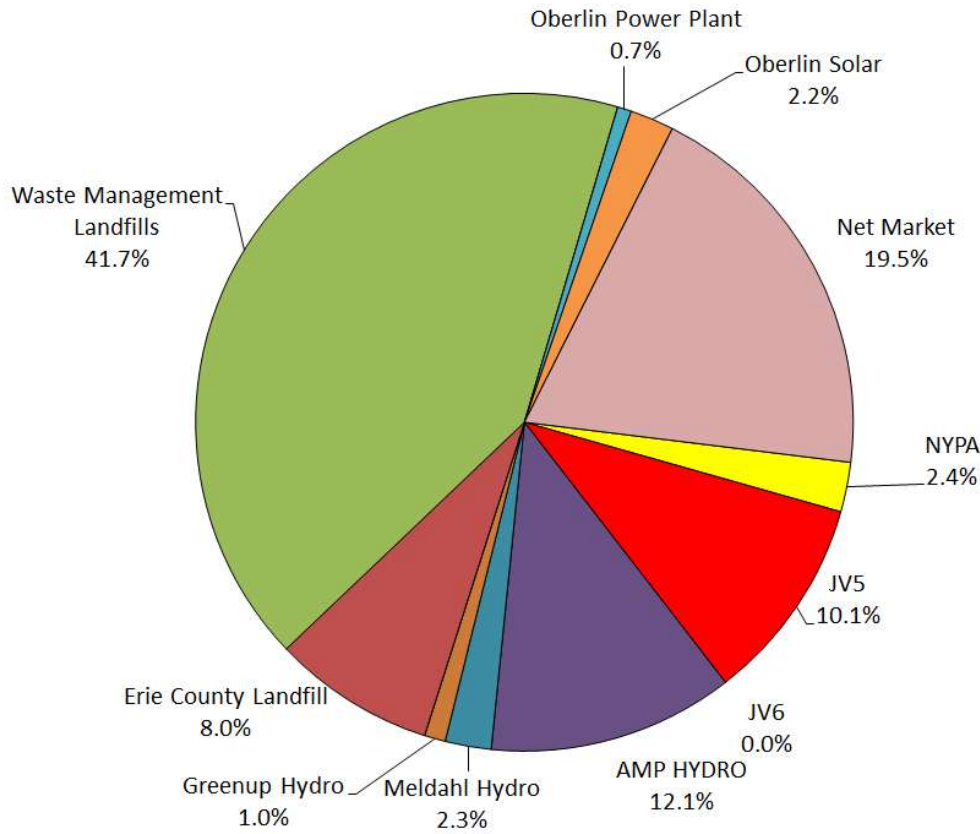

Hydro Plants and Ohio River Watershed

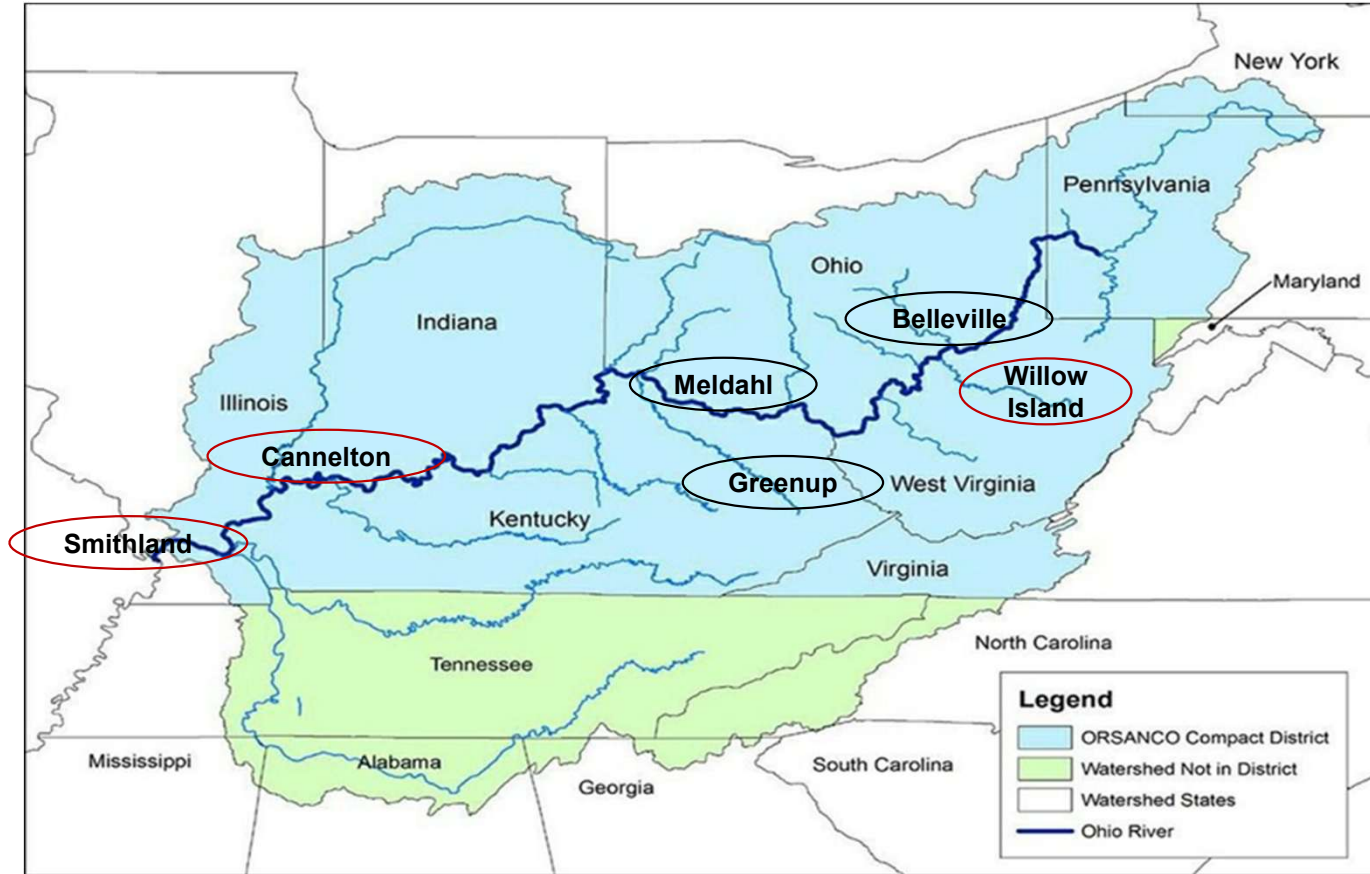

OMEGA JV5 (1,270 kW)

- 42 MW Belleville hydro project (on line 1999)
 - **Oberlin is 3.02% owner of project**
 - Debt collection through 2029
 - Approximate net rate of \$27 / MWh

NYPA (473 kW)

- New York Power Authority
- **Purchase Power Agreement**
- Current License through 2032
- Approximate net rate of \$10 / MWh



Weighted Cost of
Oberlin Hydro =
\$82 / MWh

AMP Hydro (2,598 kW)

- 208 MW project (on line 2016)
 - **Oberlin is 1.25% of project**
 - Debt collection through 2049
- Approximate net rate of \$139 / MWh

Meldahl (504 kW)

- 105 MW project (on line 2016)
 - **Oberlin is 0.48% of project**
 - Debt collection through 2049
- Approximate net rate of \$67 / MWh

Greenup (330 kW)

- 70.2 MW project (on line 1982)
 - **Oberlin is 0.47% of project**
 - Debt collection through 2045
- Approximate net rate of \$97 / MWh

Erie County Landfill (1,000 kW)

- Purchase Power Agreement through December 2028
- Located near Milan, Ohio in FirstEnergy
- Approximate net rate of \$40 / MWh
 - After Installed Capacity and 50% of RECs
 - RECs sold in Pennsylvania market



Waste Management Landfills (5,400 kW)

- Purchase Power Agreement through December 2027
- Located near Geneva, Ohio and New Springfield, Ohio (Mahoning County)
 - FirstEnergy
- Approximate net rate of \$50 / MWh
 - After Installed Capacity and 100% of RECs
 - RECs sold in Pennsylvania market



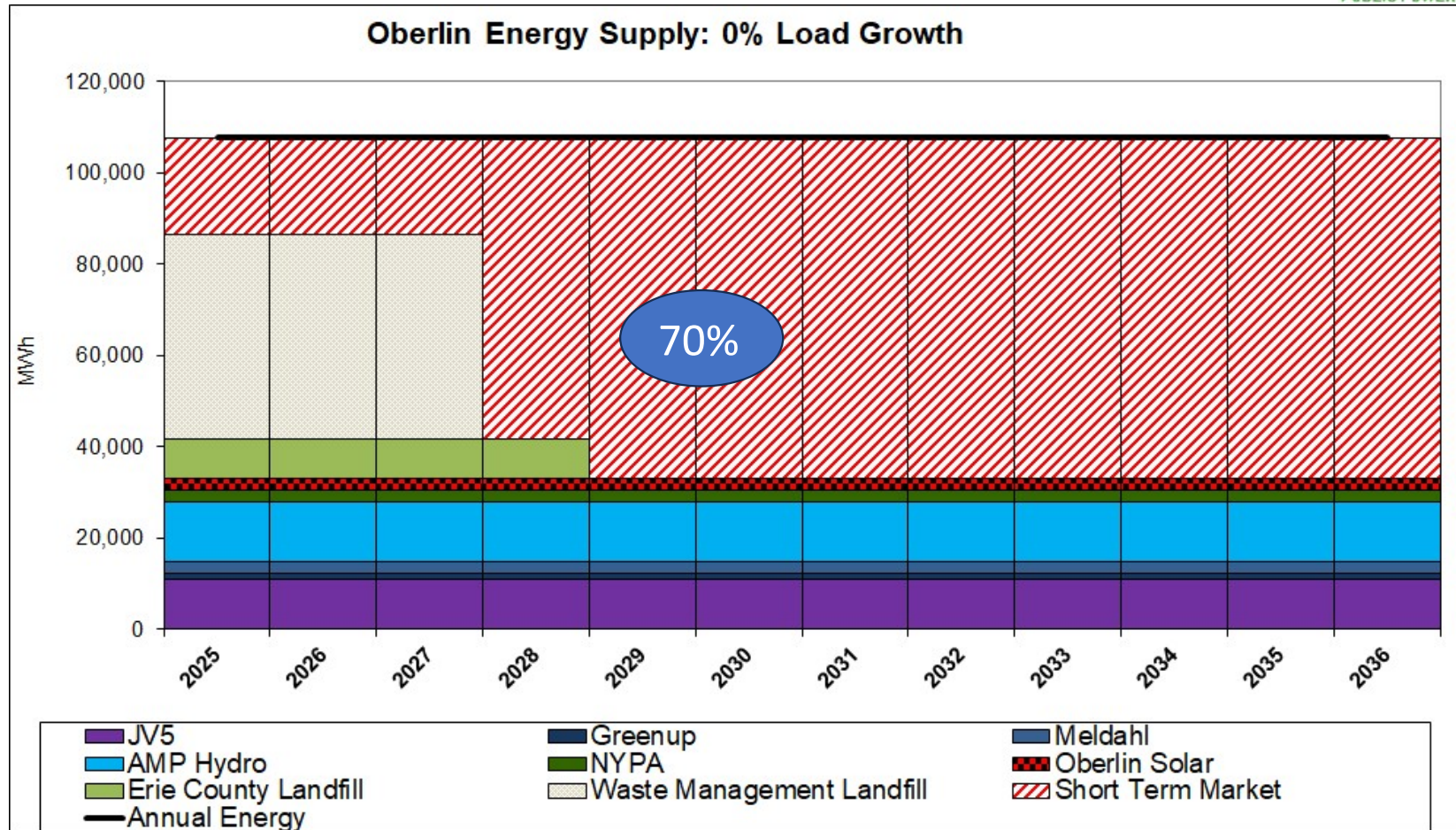

Recommended Purchase for 2027 and future

- 1.94 MW Tallgrass PPA (approximately 14% of Oberlin supply)
15-year term from January 2027 through 2042.

PPA similar to Landfill PPAs. AMP will not own the facility. We will only pay supplier for energy produced.

2027 price of \$59.50/MWh (2% per year escalation).

Approximate net rate of \$45 / MWh
After Installed Capacity and 100% of RECs
Assumes RECs sold in Ohio market

Waste Heat to Power PPAs

- Tallgrass offering two waste heat to power projects in Ohio [Chandlersville/Philo (Muskingum County) and Ashville/Columbus (Pickaway County)], totaling 22.74 MW. (AEP Zone)
 - Power from third site in Clinton County sold to University of Dayton

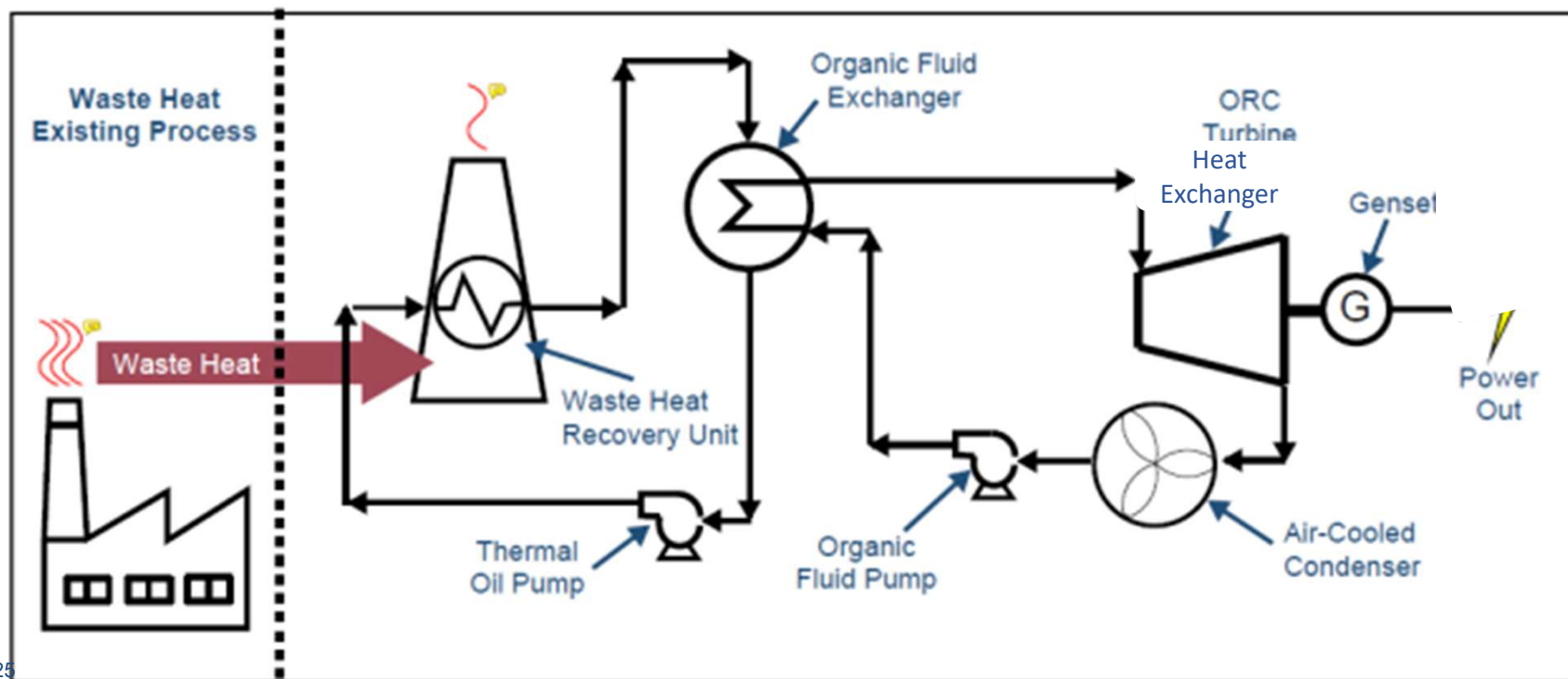

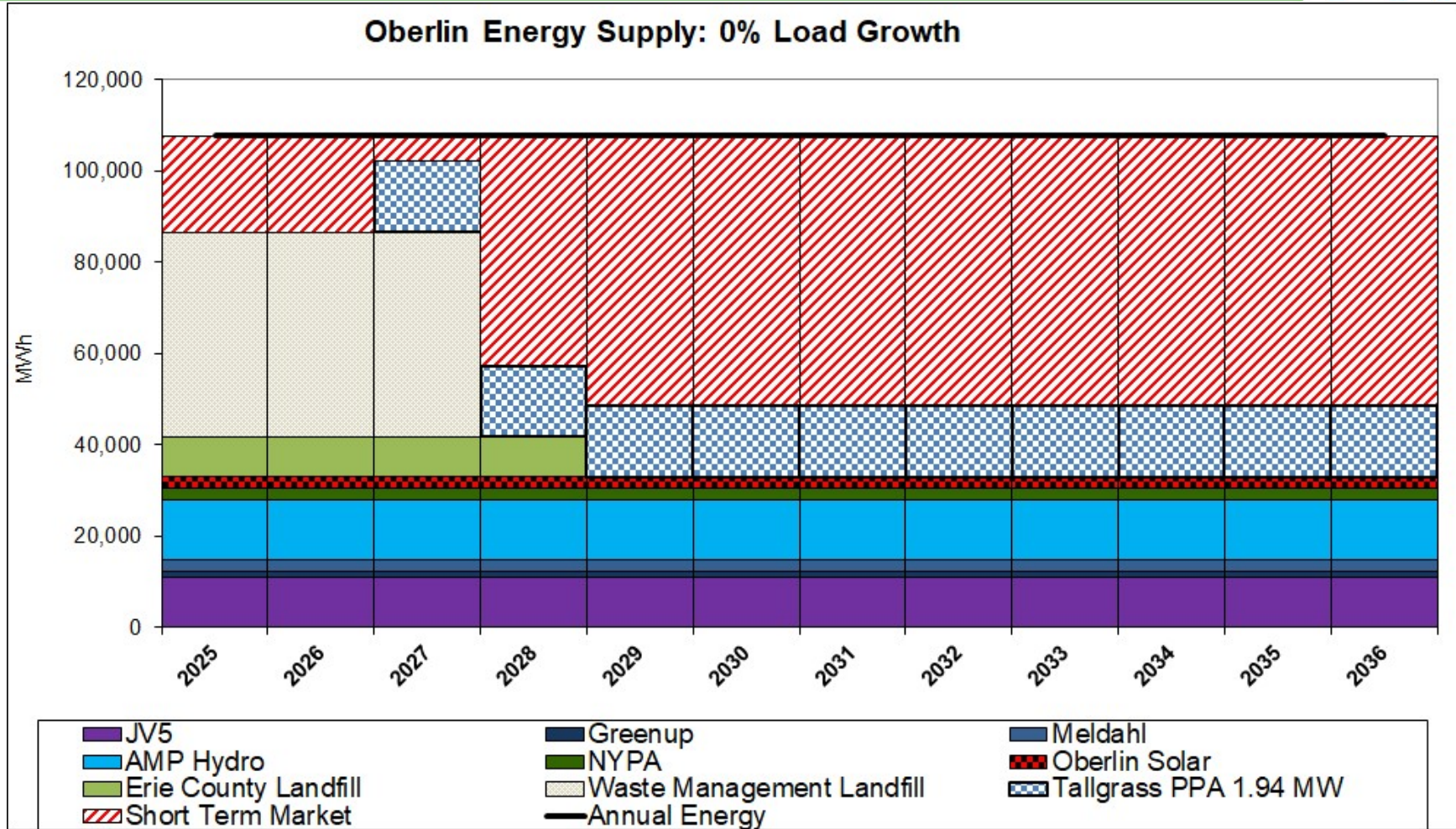

Benefits of Tallgrass PPA

- Adds to long term supply energy with renewable resource.
 - Limited amount of new renewable resources available in PJM.
- Diversifies future supply (can reduce Waste Management Landfill amount)
- Net cost is lower than current market
 - Net will be lower if RECs can be sold in other states
- Provides hedge against further increases in capacity costs

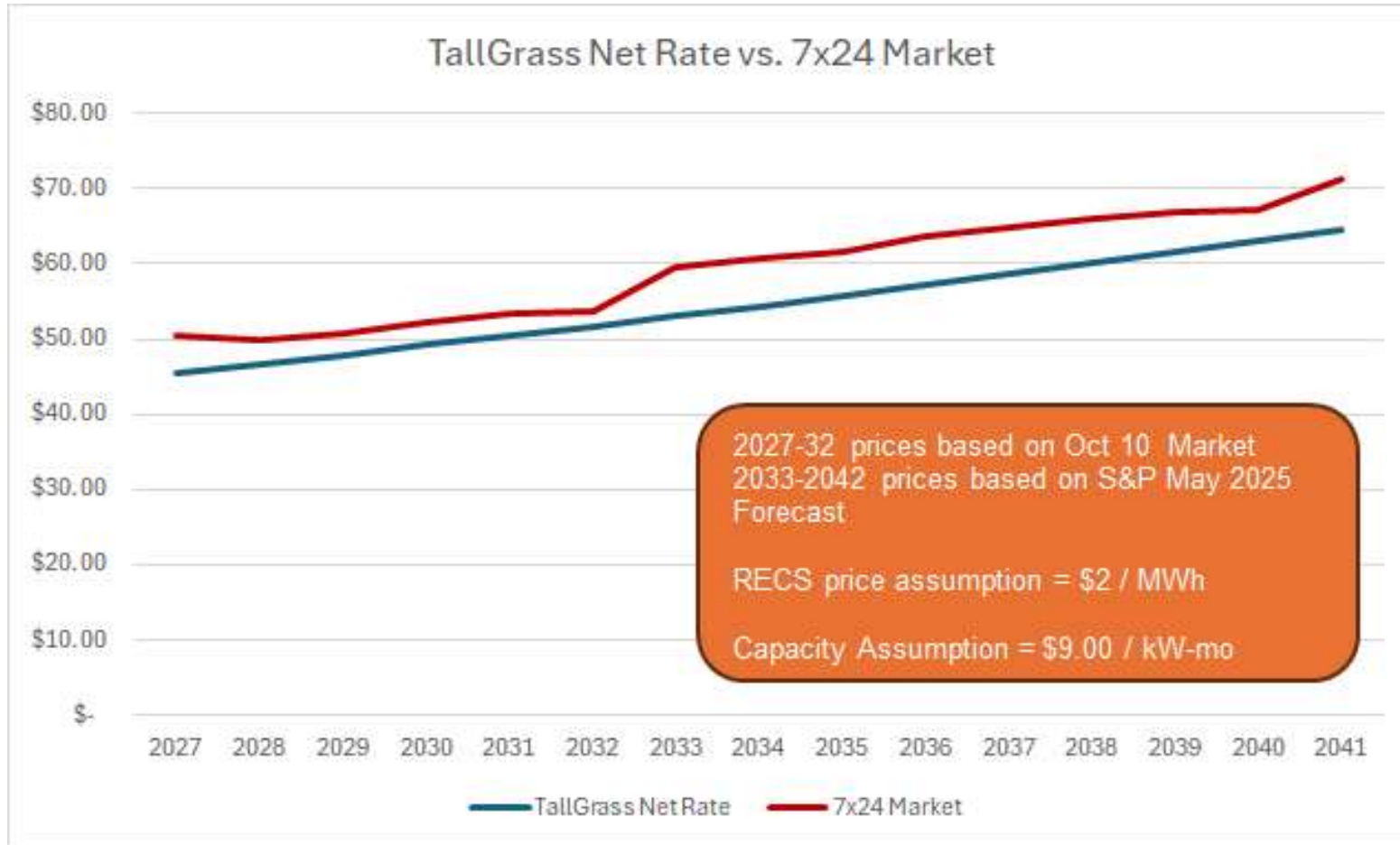

Oberlin Annual Power Rates (\$/MWh)

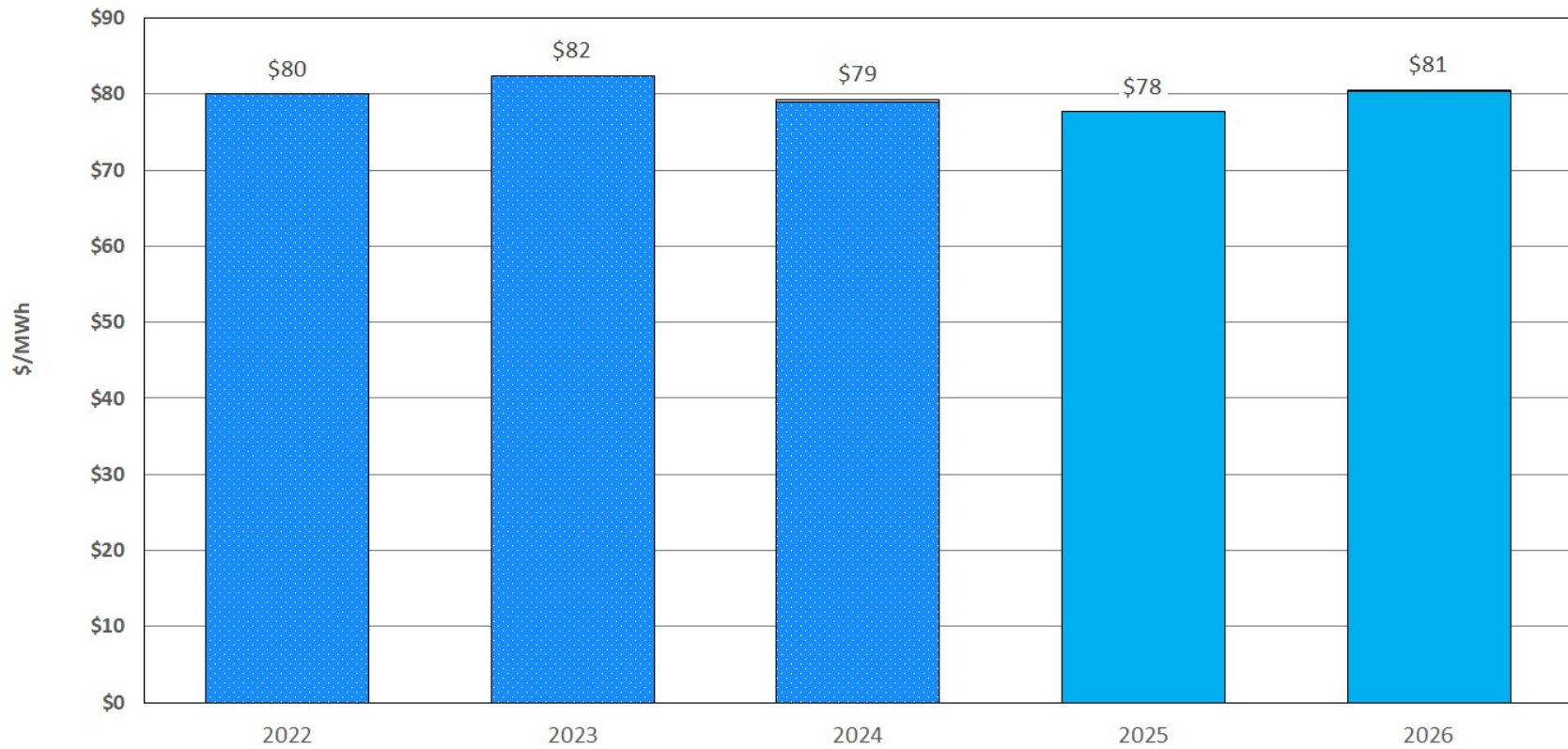

Oberlin

1,000 kWh customer pays \$145 / month
14.5 cents / kWh
 Based on past 12 mo. avg. generation charge of 9.24 cents
 ≈ 15.3 cents in 2026

	<u>2025</u>	<u>2026</u>	<u>2027</u>
Customer Charge:	\$10.00	\$12.50	\$15.00
Distribution Charge all kWh:	\$.038	\$.041	\$.044
Generation Charge:	See Generation Charge below		

The KWh Tax is applicable to all electric consumption on and after May 1, 2001. The Rates to be charged are as follows subject to automatic adjustment based on any future amendment to the Ohio Revised Code.

For a consumption period of 30 days the KWh Tax is the sum of the following:

- First 2,000 kWh consumed times \$0.00465 per kWh
- Next 13,000 kWh consumed times \$0.00419 per kWh
- Over 15,000 kWh consumed times \$0.00363 per kWh

Excise (kWh) Tax Adjustment

FE Ohio Edison Retail Rate

- Base rate approximately 9.0 cents / kWh
 - Transmission / Distribution Costs
- Generation rate for Jun 25 – May 26 = 8.2 cents / kWh

- Total FE Ohio Edison residential rate
 - **2025/2026 – 17.2 cents / kWh (Average)**

Contacts

- Mike Migliore – VP Power Supply
 - mmigliore@amppartners.org
 - 614-540-0921
- Craig Kleinhenz – Asst. VP of Power Supply Planning
 - ckleinhenz@amppartners.org
 - 614-623-7553
- Charlie Cicci - Power Supply Analyst
 - ccicci@amppartners.org
 - 614-540-1016
- Isabelle Wolford – Power Supply Analyst
 - iwolford@amppartners.org
 - 614-540-0920
- Jerry Willman – VP Energy Marketing
 - jwillman@amppartners.org
 - 614-540-6419

Waste Heat to Power Overview

- Tallgrass, owner of the Rockies Express Pipeline (REX) is developing power projects that convert waste heat at REX compressor stations to baseload, emissions free power.
- The projects utilize a process similar to a combined cycle plant, which is a proven technology to utilize otherwise waste heat into useful electric energy



Tallgrass Locations

Business Confidential - AMP Distribution & Public Record



- 9.84 MW Located in Muskingum County, Ohio
 - Connected to Guernsey-Muskingum 12kV distribution with wheeling agreement to deliver to AMP in AEP Zone
- 12.9 MW Located in Pickaway County, Ohio
 - Connected to South Central Power 69kV distribution with wheeling agreement to deliver to AMP in AEP Zone

