

MEMORIAL SITE EASEMENT AGREEMENT
Ramsey Rotary and the City of Ramsey

This agreement (this "Agreement") is entered into between the City of Ramsey, MN, a Minnesota Municipal Corporation (the "City" and sometimes "Grantor"), and the Ramsey Rotary Club, a Rotary Club sanctioned by Rotary International and designated as Rotary Club No. _____ in District 5960, (the "Rotary Club" of sometimes "Grantee").

FOR AND IN CONSIDERATION of the mutual undertakings set out, the parties agree as follows:

1. **Park Area.** Whereas, the Rotary Club desires to erect a memorial structure, at its expense in that City Park known as The Draw (the "Park") and located within the Park as shown on attached Exhibit A (the "Easement Area") which exhibit is incorporated herein by reference; and
2. **City's Memorial Policy.** Whereas, the City has by its Resolution #09-04-075 adopted a policy for accepting Park Donations, Monuments, Memorials and other Improvements, which policy is attached hereto as Exhibit B and incorporated herein by reference; and
3. **City's Memorial Maintenance Policy.** Whereas, the City by its said Resolution #09-04-075 has also adopted a policy for the maintenance of Park Donations, Monuments, Memorials and other Improvements ("Maintenance Agreement") which Maintenance Agreement is attached hereto as Exhibit C and incorporated herein by reference; and
4. **Appropriate Site.** Whereas, the City finds that the proposed memorial structure is an appropriate memorial within a City park; and
5. **Project.** Whereas, the Rotary Club's proposed memorial consists of a garden area, sculpture, flag pole and appropriate supporting structure and memorial brick pavers, modifications to the existing irrigation system and restoration with sod or seed all within the Easement Area (the "Project"); and
6. **Brick Pavers Sale.** Whereas, the Rotary Club proposes to sell the brick pavers as a fund raiser to defray the cost of the memorial construction; and
7. **Park Grading.** Whereas, the Project requires certain earth work and grading within the Easement Area prior to its construction; and
8. **City Maintenance.** Whereas, the City maintains the Park including the Easement Area, and will continue to do so except as specifically excepted herein; and
9. **Project Lighting.** Whereas, the Project requires certain specialized illuminating fixtures which are considered a part of the Project; and

10. **Rotary Club Responsibility.** Whereas, the Rotary Club is requesting that it have full responsibility for the design construction, maintenance and repair of the Project; and

11. **Rotary Club Easement.** Whereas, the Rotary Club desires to have a perpetual easement for the purpose of maintaining the Project within the Easement Area and

12. **Public Park.** Whereas, the Park is a public facility owned by the City for public purposes including recreational active park purposes.

NOW THEREFORE, in consideration of the mutual promises contained in this Agreement the parties agree as follows:

A. **Grant to Construct.** The City grants to the Rotary Club the right to construct and maintain the Project within the Park, provided the Rotary Club deems that sufficient funds have been secured to construct the full monument and facility usable and suitable for the Park. Prior to commencement of the Project, its plans and specifications shall be presented to the City for City's approval. In addition, the monument plans shall be certified by a licensed Minnesota structural engineer as being structurally sound and safe for display in the Park.

B. **Failure to Construct.** The grant to construct the Project shall expire if the Rotary Club has not commenced and substantially completed construction of the Project on or before December 31, 2014.

C. **Park Easement.** Term of the Easement shall be as follows:

- i. **Grant of Easement.** The City, as Grantor, for good and valuable consideration, hereby grants, sells and conveys to the Rotary Club as Grantee a non-exclusive easement over, under and across the Easement Area for the purposes of construction and maintenance of the Project.
- ii. **Term of Easement.** The easement will have an indefinite term commencing on the first day written above and continuing until terminated by the City by written Notice to the Rotary Club. In the event the Rotary Club is not in existence at the time of notification, written Notice to Rotary International at One Rotary Center, 1560 Sherman Avenue, Evanston, Illinois 60201 shall be deemed good and sufficient Notice. Notwithstanding the above, the City may not terminate the easement unless there has been a material breach of any of the terms of this Agreement by the Rotary Club, including failure to repair and maintain the memorial and associated appurtenances.

This easement may also be terminated at any time by the Rotary Club by written notice to the City. Such notice shall be given at least 180 days in advance of the effective date of such termination and shall be delivered either personally or by certified mail to the City Administrator at the City's main offices currently 7550 Sunwood Drive NW, Ramsey, MN 55303. Before the effective date of such termination, the Rotary Club

shall remove all of its improvements from the Easement Area at its sole cost and expense, and shall return the Easement Area to its preexisting condition or better.

D. **Condition of Premises not Warranted.** The City does not warrant that the Easement Area is suitable for the purposes for the Project and the Rotary Club assumes all risk with respect to the Project's construction and maintenance within, and use of, the Easement Area. More specifically, the City shall have no responsibility with regard to any failure of or damage to the Rotary Club's improvements within the Easement Area.

E. **Maintenance.** The Rotary Club at its expense shall be entirely responsible for maintenance of the Project and the Easement Area.

F. **Construction.** The Rotary Club at its expense shall be responsible for grading, other care work and construction of the Project.

G. **Utilities.** In the event the Rotary Club requires lighting for its monument component of the Project, it shall be responsible to install at its expense separate metered electric service and pay the on-going electric utility expense.

H. **Indemnification.** The Rotary Club shall defend, indemnify and hold harmless the City and its officers, employees and agents from and against any and all claims, demands, actions, and causes of action, including expenses, reasonable attorneys' fees, and costs of alternative dispute resolution, arising out of or related to the Rotary Club's construction and maintenance of the Project within, and use of, the Easement Area.

I. **Governing Law.** This Agreement shall be governed by and construed and enforced in accordance with the laws of the State of Minnesota.

J. **Entire Agreement.** This Agreement shall constitute the entire agreement of the parties and any prior understanding or representation of any kind preceding the date of this Agreement shall not be binding upon either party except to the extent incorporated in this Agreement.

K. **Modification of Agreement.** Any modification of this Agreement shall be binding only if evidenced in writing signed by both parties.

L. **Recording.** This Agreement may be recorded with the Anoka County Recorder by either party at the expense of that party.



SITE PLAN

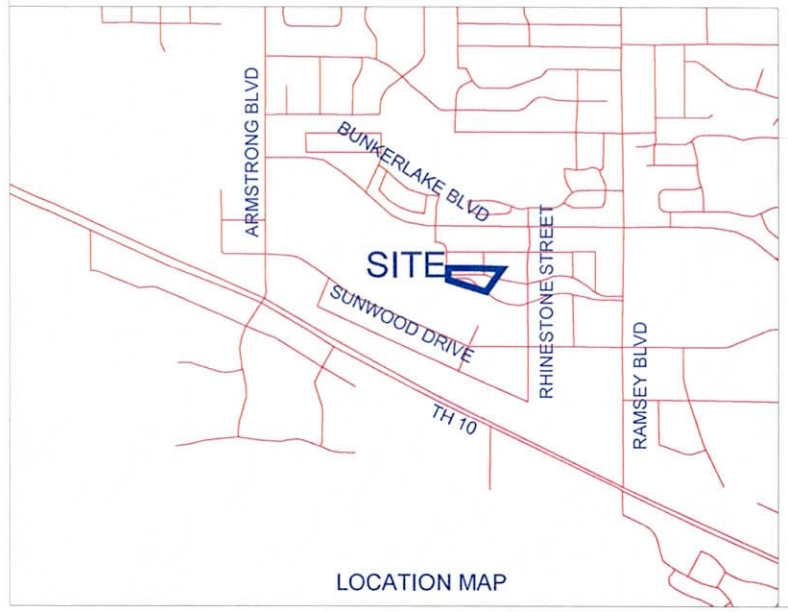

LOCATION MAP

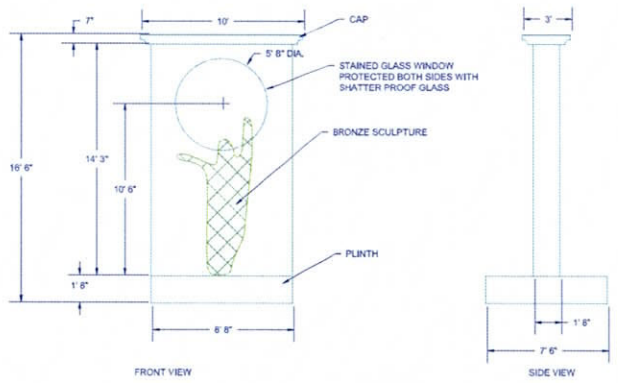

SCULPTURE DETAIL

THE DRAW SCULPTURE AND MEMORIAL

Blumberg No. 5208
EXHIBIT
A

Councilmember Elvig introduced the following resolution and moved for its adoption:

RESOLUTION #09-04-075

**RESOLUTION ADOPTING POLICY FOR ACCEPTING PARK DONATIONS, MONUMENTS,
MEMORIALS, AND OTHER IMPROVEMENTS**

WHEREAS, a formal policy for accepting park donations, monuments, memorials, and other improvements is needed to absorb donation proposals in a manner that is consistent with the goals of the City Parks and Recreation System; and

WHEREAS, this policy is needed to provide a standard procedure for accepting park donations; and

WHEREAS, the City encourages donations of land, facilities, equipment, park improvements and money to support the Parks and Recreation system.

NOW THEREFORE, BE IT RESOLVED BY THE CITY COUNCIL OF THE CITY OF RAMSEY, ANOKA COUNTY, STATE OF MINNESOTA, as follows:

That the Ramsey City Council hereby approves the attached Policy for Accepting Park Donations, Monuments, Memorials, and Other Improvements dated April 14th 2009.

The motion for the adoption of the foregoing resolution was duly seconded by Councilmember McGlone and upon vote being taken thereon, the following voted in favor thereof:

Mayor Ramsey
Councilmember Elvig
Councilmember McGlone
Councilmember Dehen
Councilmember Jeffrey
Councilmember Look
Councilmember Wise

and the following voted against the same:

None

and the following abstained:

None

and the following were absent:

None



whereupon said resolution was declared duly passed and adopted by the Ramsey City Council this the 14th day of April, 2009.

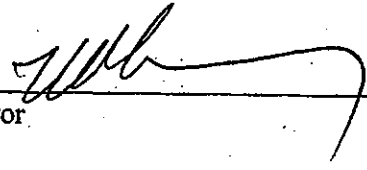

Mayor

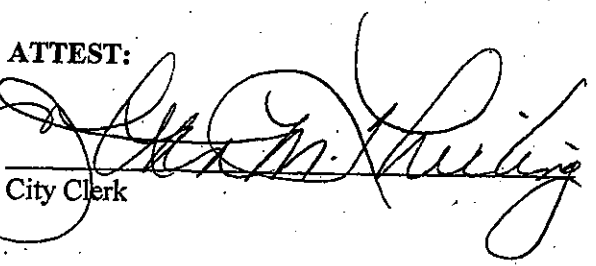
ATTEST:

City Clerk

POLICY FOR ACCEPTING PARK DONATIONS, MONUMENTS, MEMORIALS, AND OTHER IMPROVEMENTS

Purpose:

The purpose of this policy is to provide guidelines for accepting donations for park facilities and granting donor recognition within the City Parks and Recreation system.

Scope:

This policy applies within all Existing Developed City Parks and Planned City Parks identified in the City Capital Improvements Plan, the City Park and Trails Map, or the City Parks Plan.

Policy:

1. The City encourages donations of land, facilities, equipment, park improvements and money to support the Parks and Recreation system.
2. All donations must respond to a recognized need within the Parks and Recreation System.
3. No donations may detract from the primary recreational objectives of the receiving park.
4. Administrative approval may be granted for the following types of donations:
 - a. [\$200] [plus the cost of installation, maintenance, and purchase] for a Park Bench with a commemorative plaque,
 - b. [\$200] [plus the cost of installation, maintenance, and purchase] for a Park Tree with a commemorative plaque,
 - c. Any monetary donation toward a need identified in the City Parks Plan.
5. Park benches and trees must be installed by the City and purchased from the City. Benches and trees will be maintained in a reasonable state by the City for an agreed upon time-frame.
6. Commemorative plaques may honor a special person, organization, or event, but honor to persons should be worded in a way that does not imply a loss of life. For example (In honor of...) or (Celebrating...) are more acceptable messages than (In memory of...) or (In remembrance of...).
7. Donations not eligible for administrative approval may be accepted only through the vote of the City Council. All such donations must cover the cost of administrative review, and must first be considered by the Parks and Recreation Commission.
8. Donations of any kind become the property of the City of Ramsey.

9. Unless other agreements have been made with the donor, the City is responsible for the construction, installation and maintenance of improvements, and selection of equipment paid for by the donor.
10. Available forms of donor recognition include the placement of a plaque or marker located proximate to location of donated improvements;
11. If a financial contribution exceeding 60% of the cost of major planned improvements is made, naming rights for new parks and recreational facilities may be granted through City Council approval.
12. No donation may reflect a political or religious statement or position; and may not mention any form of deity.
13. The City reserves the right to remove or alter any donated equipment or improvements.
14. Donor recognition will be maintained for an agreed upon time-frame.

Adoption

This foregoing Policy for Accepting Park Donations, Monuments, Memorials, and Other Improvements, was adopted by a vote the Ramsey City Council adopting Resolution #09-04-075 on this the 14th day of April, 2009.



Mayor

ATTEST:



City Clerk

MAINTENANCE AGREEMENT

1. The memorial garden park project is supported by donations of the Rotary and independent companies.
2. The City shall perform the initial grading for the site at no cost to the Rotary.
3. The City shall maintain all necessary areas in the Park.
4. The Rotary shall be prohibited from performing any maintenance to Park areas without written permission from the City.
5. The City shall provide and maintain all area lighting systems.
6. The Rotary will be responsible for the long-term maintenance and repair of the statue.
7. The Rotary is in charge of the commemorative park project in the Park, utilizing the existing memorial policy to cover the memorial brick pavers.
8. The memorial policy is attached.

