

City of Ramsey
Agenda
Housing and Redevelopment Authority (HRA)
Work Session
Tuesday September 4, 2012
Immediately Following CC Work Session
Lake Itasca Room, 7550 Sunwood Drive NW

- 1. Call to Order**
- 2. Topics for Discussion**
 1. 2013 HRA Budget & Levy
 2. Discuss Sign Package and Design Framework Modifications
- 3. Development Team Report**
- 4. Commissioner Input**
- 5. Adjournment**

HRA Work Session

2. 1.

Meeting Date: 09/04/2012**By:** Diana Lund, Finance**Information****Title:**

2013 HRA Budget & Levy

Background:

The city council was presented with the proposed 2013 HRA budget and levy at the worksession of August 28, 2012. Much inquiry was made in regard to the funds held at Anoka County HRA and the availability of those funds in regard to reducing the City HRA's levy.

Staff contacted Karen Skepper of the Anoka County HRA and got a further clarification of the use of these funds. To quote Ms. Skepper: "The use of the Anoka County HRA funds need to be tied to eligible projects. There may be ways to use the funding for the city HRA budget, but a copy of the budget and a resolution from the city council is needed to bring to the Anoka County HRA Board. In the past, funding for very specific projects have always been approved. It is likely that there will be considerable discussion in regards to the city's budget and there is the potential for some line items to be approved and others denied. I'm certain that reserves will not be allowed as we are statutorily obligated to only expend the HRA levy in eligible areas. I can't anticipate what the reaction of the board would be to funding an entire budget".

Notification:

A line-item detail of the transactions of the HRA for the last three years will be presented at the worksession.

Recommendation:

Based upon the uncertainty of a County approval of the use of it's levy authority, to fund all or part of the City's HRA function, It is recommended that the city the proposed levy amount at the September 11, 2012 HRA meeting. A revised final levy in December could be based upon an approved County action as requested by the City.

Funding Source:

Not Applicable

Council Action:

Discussion of the HRA budget and levy

Attachments[2013 HRA budget](#)[County HRA funding](#)[Levy Comparisons 2007-2013](#)**Form Review**

Inbox	Reviewed By	Date
Kurt Ulrich	Diana Lund	08/30/2012 03:35 PM
Diana Lund (Originator)	Diana Lund	08/30/2012 03:38 PM
Kurt Ulrich	Kurt Ulrich	08/30/2012 04:33 PM
Form Started By: Diana Lund		Started On: 08/30/2012 03:14 PM
	Final Approval Date: 08/30/2012	

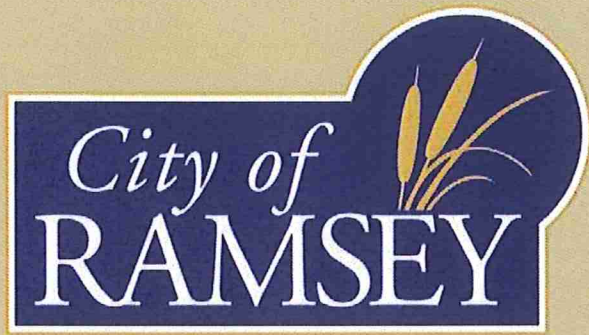

CITY OF RAMSEY
HOUSING REDEVELOPMENT AUTHORITY
REQUESTED BUDGET
For Fiscal Year 2013

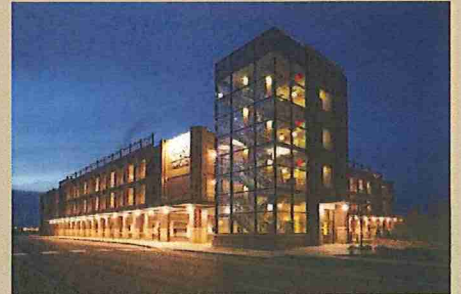

City of Ramsey
2013 Requested Housing Redevelopment Authority Fund Budget

HOUSING REDEVELOPMENT AUTHORITY FUND 295 - SUMMARY

REVENUES

	-Actual 2009-	-Actual 2010-	-Actual 2011-	-Adopted 2012-	-Requested 2013-
TAXES	547,631	383,005	346,428	368,532	328,567
INTERGOVERNMENTAL REVENUES	13,722				
INVESTMENT EARNINGS	24,699	5,000	2,500	2,500	2,500
MISCELLANEOUS	6,446,837	5	34,395	-	-
OTHER FINANCING SOURCES	1,583,185	5,000	136,302	-	-
TOTAL REVENUES	8,616,074	393,010	519,625	371,032	331,067

EXPENDITURES

	-Actual 2009-	-Actual 2010-	-Actual 2011-	-Adopted 2012-	-Requested 2013-
PERSONAL SERVICES	97,849	43,084	150,015	130,251	130,268
SUPPLIES		76,482	59,826	30,000	30,000
OTHER SERVICES & CHARGES	441,023	423,163	433,741	347,160	170,799
CAPITAL OUTLAY			111,669	-	-
TRANSFERS OUT					
TOTAL EXPENDITURES	538,873	542,729	755,251	507,411	331,067

FUND BALANCE

	-Actual 2009-	-Actual 2010-	-Actual 2011-	-Adopted 2012-	-Requested 2013-
FUND BALANCE, Beginning on Yr	621,442	751,807	602,088	366,462	230,083
Revenues & Other Sources	7,433,666	393,010	519,625	371,032	331,067
Expenditures & Other Uses	(7,303,301)	(542,729)	(755,251)	(507,411)	(331,067)
FUND BALANCE, End of Yr	751,807	602,088	366,462	230,083	230,083

City of Ramsey
2013 Requested Housing Redevelopment Authority Fund Budget

HOUSING REDEVELOPMENT AUTHORITY FUND 295 - REVENUE DETAIL

2009 Actual 2010 Actual 2011 Actual 2012 Adopted 2013 Requested

HRA FUND 9295 - REVENUE SUMMARY	-Actual 2009-	-Actual 2010-	-Actual 2011-	-Adopted 2012-	-Requested 2013-
TAXES	547,631	383,005	346,428	368,532	328,567
INTERGOVERNMENTAL REVENUES	13,722				
INVESTMENT EARNINGS	24,699	5,000	2,500	2,500	2,500
MISCELLANEOUS	6,446,837	5	34,395	-	
OTHER FINANCING SOURCES	1,583,185	5,000	136,302	-	
TOTAL REVENUES	8,616,074	393,010	519,625	371,032	331,067

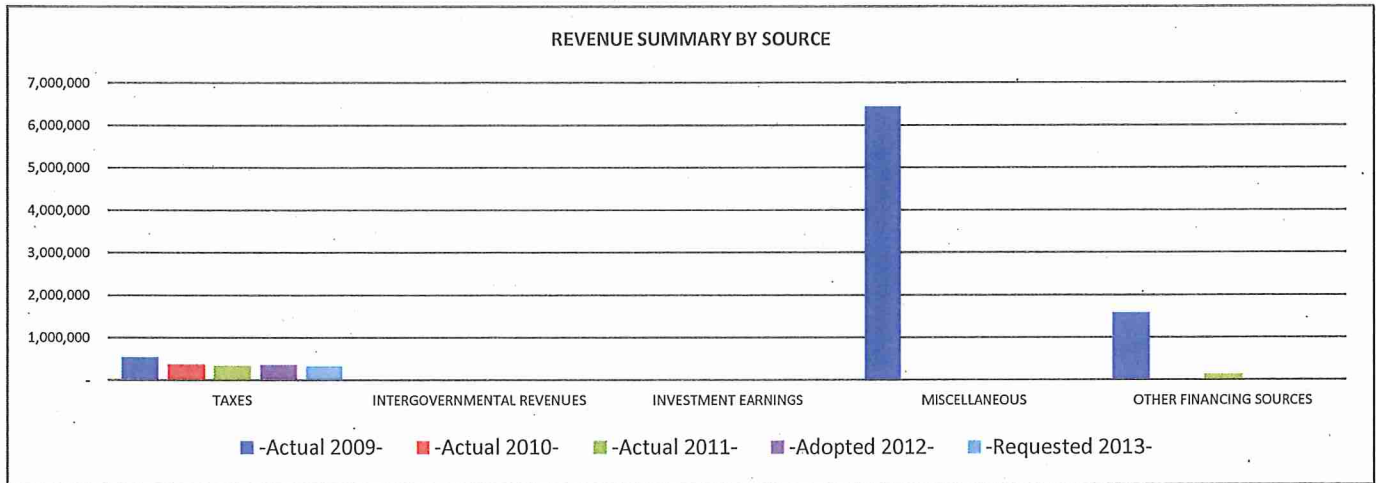

HRA FUND 9295 - REVENUE BY SOURCE		-Actual 2009-	-Actual 2010-	-Actual 2011-	-Adopted 2012-	-Requested 2013-
TAXES						
4011	CURRENT-AD VALOREM TAXES	488,127	383,005	270,931	368,532	328,567
4012	DELINQUENT-AD VALOREM TAXES	16,263		5,517	-	
4014	FISCAL DISPARITIES	43,241		69,980	-	
TAXES Total		547,631	383,005	346,428	368,532	328,567
INTERGOVERNMENTAL REVENUES						
- STATE INTERGOVERNMENTAL						
4263	MARKET VALUE HOMESTEAD CREDIT	13,722				
INTERGOVERNMENTAL REVENUES Total		13,722				
INVESTMENT EARNINGS						
4701	INTEREST ON INVESTMENTS	24,699	5,000	2,500	2,500	2,500
INVESTMENT EARNINGS Total		24,699	5,000	2,500	2,500	2,500
MISCELLANEOUS						
4609	OTHER MISCELLANEOUS REVENUES	595,641	5	34,395	-	
4723	SPECIAL REVENUE-UNUSUAL EVENT	5,851,196				
MISCELLANEOUS Total		6,446,837	5	34,395	-	
OTHER FINANCING SOURCES						
TRANSFERS IN						
4901	TRANSFER IN FROM OTHER FUNDS	1,583,185	5,000	136,302	-	
OTHER FINANCING SOURCES Total		1,583,185	5,000	136,302	-	
TOTAL REVENUE		8,616,074	393,010	519,625	371,032	331,067

City of Ramsey
2013 Requested Housing Redevelopment Authority Fund Budget

2009 Actual	2010 Actual	2011 Actual	2012 Adopted	2013 Requested
-------------	-------------	-------------	--------------	----------------

HOUSING REDEVELOPMENT AUTHORITY FUND 295 - REVENUE DETAIL

	2009 Actual	2010 Actual	2011 Actual	2012 Adopted	2013 Requested
4011 Current Ad Valorem Taxes					
((includes taxes from Town Center)	561,353	383,005	346,428	368,532	328,567
	561,353	383,005	346,428	368,532	328,567
4701 Interest Earnings					
	24,699	5,000	2,500	2,500	2,500
	24,699	5,000	2,500	2,500	2,500
4609 Miscellaneous Revenues					
Earnest Money - TOTI			34,395	-	-
County HRA payment towards RTC land purchase	595,641	5	-	-	-
	595,641	5	34,395	-	-
4901 Transfers in from other funds					
Letter of Credit Proceeds & Sewer/Water Loan	1,583,185	5,000	-	-	-
Non TIF Interest Earnings	0	0	136,302	-	-
	1,583,185	5,000	136,302	-	-

City of Ramsey
2013 Requested Housing Redevelopment Authority Fund Budget

HOUSING REDEVELOPMENT AUTHORITY FUND 295 - EXPENDITURE DETAIL

	2009 Actual	2010 Actual	2011 Actual	2012 Adopted	2013 Requested
EXPENDITURE BY OBJECT SUMMARY					
PERSONAL SERVICES	97,849	43,084	150,015	130,251	130,268
SUPPLIES		76,482	59,826	30,000	30,000
OTHER SERVICES & CHARGES	441,023	423,163	433,741	347,160	170,799
CAPITAL OUTLAY			111,669		
TRANSFERS OUT					
TOTAL EXPENDITURE BY OBJECT	538,873	542,729	755,251	507,411	331,067

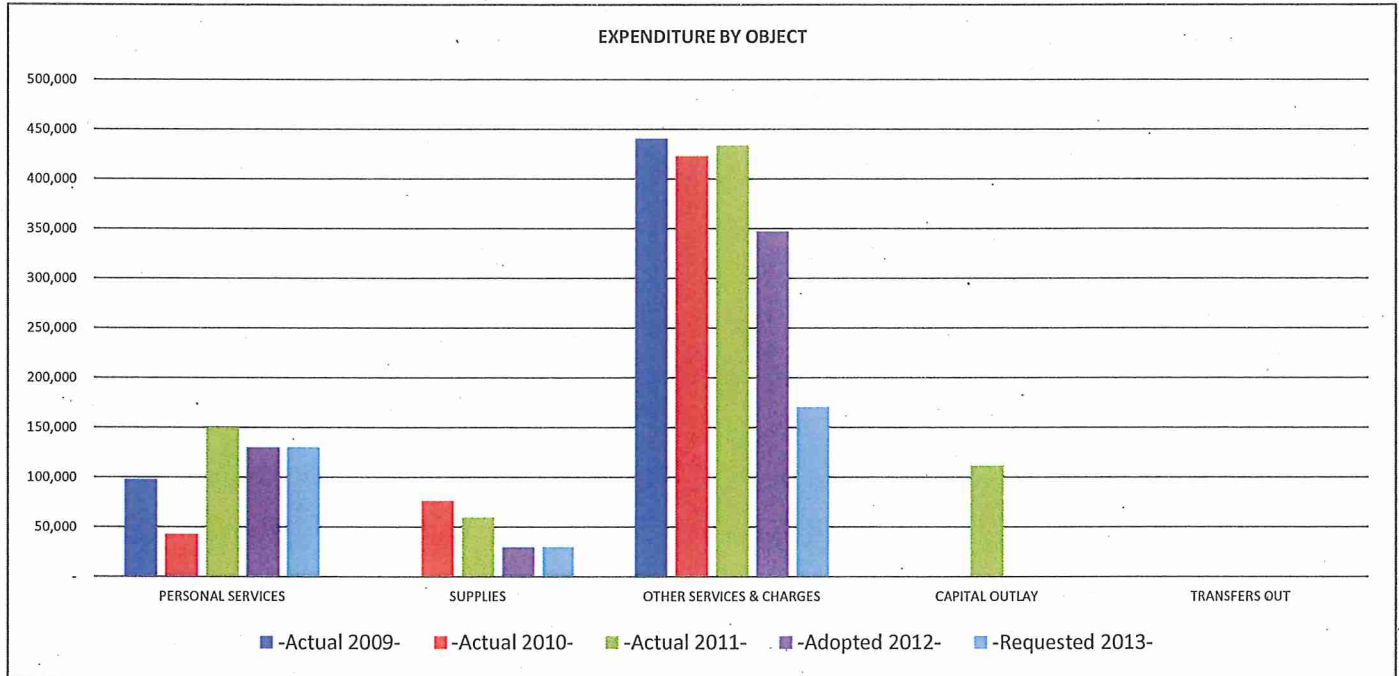

EXPENDITURE BY OBJECT RECAP		-Actual 2009-	-Actual 2010-	-Actual 2011-	-Adopted 2012-	-Requested 2013-
PERSONAL SERVICES						
WAGES AND SALARIES						
6102	F.T. REGULAR-WAGES & SALARIES	84,591	37,221	123,895	100,129	107,410
6104	PART TIME-WAGES & SALARIES			6,175	8,400	6,000
6105	TEMPORARY-WAGES & SALARIES			-	6,000	-
WAGES AND SALARIES		84,591	37,221	130,070	114,529	113,410
EMPLOYER CONTRIBUTIONS						
6121	PERA CONTRIBUTIONS	5,710	2,605	8,983	7,259	7,787
6122	FICA/MEDICARE CONTRIBUTIONS	6,472	2,847	9,973	7,660	8,217
6133	WORKERS COMP INSURANCE PREMIUM	1,076	411	989	803	854
EMPLOYER CONTRIBUTIONS		13,258	5,863	19,945	15,722	16,858
PERSONAL SERVICES Total		97,849	43,084	150,015	130,251	130,268
SUPPLIES						
OPERATING SUPPLIES						
6246	MARKETING & PROMOTIONS		76,264	59,350	30,000	30,000
6249	MISCELLANEOUS OPERATING SUPPLY		218	476	-	-
OPERATING SUPPLIES			76,482	59,826	30,000	30,000
SUPPLIES Total			76,482	59,826	30,000	30,000

City of Ramsey
2013 Requested Housing Redevelopment Authority Fund Budget

HOUSING REDEVELOPMENT AUTHORITY FUND 295 - EXPENDITURE DETAIL

	2009 Actual	2010 Actual	2011 Actual	2012 Adopted	2013 Requested
OTHER SERVICES & CHARGES					
PROFESSIONAL SERVICES					
6304 LEGAL FEES	1,198	29,847	77,390	25,000	35,000
6315 MISCELLANEOUS PROFESSIONAL SER	437,184	323,886	284,525	240,000	51,499
PROFESSIONAL SERVICES	438,382	353,733	361,915	265,000	86,499
COMMUNICATION					
6322 POSTAGE		27	938	1,000	1,000
COMMUNICATION		27	938	1,000	1,000
EMPLOYEE REIMBURSEMENTS					
6331 TRAVEL & LODGING	-	11,366	19,858	20,000	20,000
6334 MILEAGE REIMBURSEMENT			36	500	400
6335 TRAINING	989	3,655	242	2,500	2,000
EMPLOYEE REIMBURSEMENTS	989	15,021	20,136	23,000	22,400
INSURANCE					
6361 GENERAL LIABILITY/PROPERTY INS	1,652	4,562	3,004	-	6,000
INSURANCE	1,652	4,562	3,004	-	6,000
UTILITIES					
6371 ELECTRIC UTILITIES			50	6,500	3,000
UTILITIES			50	6,500	3,000
DUES, SUBSCRIPTIONS, AND REGISTRATION FEES					
6451 MEMBERSHIP DUES	-	2,160	-	3,500	3,500
6452 SUBSCRIPTIONS	-	-	98	500	400
DUES, SUBSCRIPTIONS, AND REGISTRATION FEES	-	2,160	98	4,000	3,900
CONTRACTED SERVICES					
6489 OTHER CONTRACTED SERVICES		47,660	47,600	47,660	48,000
CONTRACTED SERVICES		47,660	47,600	47,660	48,000
OTHER SERVICES & CHARGES Total	441,023	423,163	433,741	347,160	170,799
TOTAL EXPENDITURES & OTHER FINANCING	538,873	542,729	643,582	507,411	331,067

	2009 Actual	2010 Actual	2011 Actual	2012 Adopted	2013 Requested
6102 Wages & Salaries					
Personnel	84,591	37,221	123,895	100,129	107,410
	84,591	37,221	123,895	100,129	107,410
6105 Wages & Salaries-Part Time					
Stipend for HRA Meeting \$25/mtg	-	-	6,175	8,400	6,000
	-	-	6,175	8,400	6,000
6105 Temporary Wages & Salaries					
Temporary Labor-Maintenance	-	-	-	6,000	-
	-	-	-	6,000	-
6246 Marketing & Promotional Supplies					
COR Website Domains	-	2,234	1,750	3,000	3,000
COR Marketing	-	74,030	57,600	27,000	27,000
	-	76,264	59,350	30,000	30,000
6249 Miscellaneous Operating Supplies					
Miscellaneous	-	218	476	-	-
	-	218	476	-	-
6304 Legal Fees					
Legal Fees	1,198	29,847	77,390	25,000	35,000
	1,198	29,847	77,390	25,000	35,000

City of Ramsey
2013 Requested Housing Redevelopment Authority Fund Budget

HOUSING REDEVELOPMENT AUTHORITY FUND 295 - EXPENDITURE DETAIL

	2009 Actual	2010 Actual	2011 Actual	2012 Adopted	2013 Requested
6315 Miscellaneous Professional Services					
Development Management Contract & Exp	-	311,750	267,944	210,000	30,000
Property Taxes	323,185	-	-	-	-
Misc Consulting Services	113,999	12,136	15,996	30,000	21,499
	437,184	323,886	283,940	240,000	51,499
6322 Postage					
Mailing Housing Surveys	-	27	938	1,000	1,000
	-	27	938	1,000	1,000
6331 Travel/Meals/Lodging					
Travel for COR	-	11,366	19,858	20,000	20,000
	-	11,366	19,858	20,000	20,000
6334 Mileage Reimbursement					
Reimbursement for personal use of auto	-	-	36	500	400
	-	-	36	500	400
6335 Training					
Misc HRA Conferences	989	3,655	242	2,500	2,000
	989	3,655	242	2,500	2,000
6361 General Liability/Property/Auto Insurance					
Share of applicable insurance coverage.	1,652	4,562	5,865	-	6,000
	1,652	4,562	5,865	-	6,000
6371 Electric Utilities					
Electric for COR Sign	-	-	109	6,500	3,000
	-	-	109	6,500	3,000
6451 Dues					
ICSC	-	2,160	-	3,500	3,500
	-	2,160	-	3,500	3,500
6452 Subscriptions					
MN Real Estate Journal & Business Journal	-	-	98	500	400
	-	-	98	500	400
6489 Other Contracted Services					
Park Ramp Maintenance Agreement	-	47,660	47,600	47,660	48,000
	-	47,660	47,600	47,660	48,000

2013 PROPOSED HRA LEVY

Maximum Levy	\$ 328,567.00 (.0185x\$1,776,038,835)
Annual County HRA Levy \$'s Undesignated	\$ 236,000.00

2013 Possible Levy Scenarios:

<u>Annual County Levy %</u>	<u>County HRA \$'s</u>	<u>Amount Levied</u>	<u>Effect on Taxpayer of \$200,000 Home</u>
	\$ -	\$ 328,567.00	\$ 37.00
25%	\$ 59,000.00	\$ 269,567.00	\$ 30.36
50%	\$ 118,000.00	\$ 210,567.00	\$ 23.71
75%	\$ 177,000.00	\$ 151,567.00	\$ 17.07
100%	\$ 236,000.00	\$ 92,567.00	\$ 10.42

Levy Comparisons for Years 2006-2013

	Payable 2007	Payable 2008	Payable 2009	Payable 2010	Payable 2011	Payable 2012	Payable 2013
General	\$ 6,884,480	\$ 7,610,338	\$ 8,092,034	\$ 7,194,194	\$ 6,992,127	\$ 6,997,150	\$ 7,248,829
EDA	\$ 393,375	\$ 393,375	\$ 291,705	\$ 291,705	\$ 291,705	\$ 169,853	\$ 104,466
Debt Service	\$ 1,247,126	\$ 1,012,112	\$ 1,091,999	\$ 1,056,431	\$ 844,777	\$ 1,246,795	\$ 644,918
Total Levy	\$ 8,524,981	\$ 9,015,825	\$ 9,475,738	\$ 8,542,330	\$ 8,128,609	\$ 8,413,798	\$ 7,998,213
HRA (2006 first levy year) (.0185 total tax mkt value)	\$ 312,443	\$ 312,443	\$ 312,443	\$ 408,765	\$ 368,549	\$ 368,549	\$ 328,567
GRAND TOTAL ALL LEVIES	\$ 8,837,424	\$ 9,328,268	\$ 9,788,181	\$ 8,951,095	\$ 8,497,158	\$ 8,782,347	\$ 8,326,780

HRA Work Session

2. 2.

Meeting Date: 09/04/2012

By: Darren Lazan, Housing &
Redevelopment Authority

Information

Title:

Discuss Sign Package and Design Framework Modifications

Background:

At the regular HRA meeting on August 28, 2012, the HRA approved the expenditure for modifications and additions to The COR Design Framework.

The current draft of The COR Design Framework was approved by the HRA and adopted by the City Council on February 28, 2012. As presented in those meetings, this document serves to provide both the necessary zoning and design controls for The COR, and was intended to evolve and expand as the project moved forward.

At the time of adoption, the master signage portion of the project was very schematic. It indicated a desire to have three general components to the project that would be detailed in a future appendix as development occurs. These were generally described as Community Signs, Project Gateway Signs, and directional or informational signs.

Contemplated in the main body of the framework, were some revisions to the building and site signage requirements for individual developments in The COR.

Notification:

In working through the purchase agreements for the three lots in the Sunwood Retail area, we have had the opportunity to spend considerably more time on both the master signage, as well as the individual signage for these projects.

Attached to this case:

- A current draft of the Master Signage Plan
- A working draft of Appendix B to the Design Framework. This contains all the examples of master signage in the project for your consideration and discussion.
- A current draft of a freestanding multi-tenant sign

If the design and signage concepts are acceptable, there are additions and modifications to the design framework necessary to prepare for adaption by the City Council. The planning budget previously allocated to the design framework effort was exhausted with the adapted document effort. Because this effort is predominantly related to the master developers role in establishing a master signage plan, the development team recommends the HRA consider a contribution to the effort to continue the development of these standards. It is estimated to be an professional services effort of approximately \$10,000 in drafting necessary sections and preparing final exhibits.

Observations:

The discussion items for the HRA are as follows:

- Review the proposed master sign plan concepts for gateway and directional signage.
- Review the proposed free-standing tenant signs
- Provide direction on the establishment and adaption of Appendix B to the Design Framework

Recommendation:

The development team recommends the HRA review the design concepts and structure of the framework modifications, and provide input and consensus direction on the preparation of necessary revisions.

Funding Source:

HRA Professional Services Budget

Council Action:

Provide consensus direction on the draft master signage documents and provide input to the development team from which to proceed with the preparation of Appendix B and necessary modifications to the Design Framework.

Attachments

Master Sign Plan - Draft

Appendix B - Draft

Multi-Tenant Sign - Draft

Form Review

Inbox
Tim Gladhill
Kurt Ulrich

Reviewed By
JoAnn Shaw
Kurt Ulrich

Date
08/30/2012 03:51 PM
08/30/2012 04:35 PM
Started On: 08/30/2012

Form Started By: Darren Lazan

Final Approval Date: 08/30/2012

PYLON/COMMUNITY SIGNS

-  COMMUNITY KIOSK
-  PROJECT GATEWAY
-  PARKING

*See 'Appendix B' for sign details

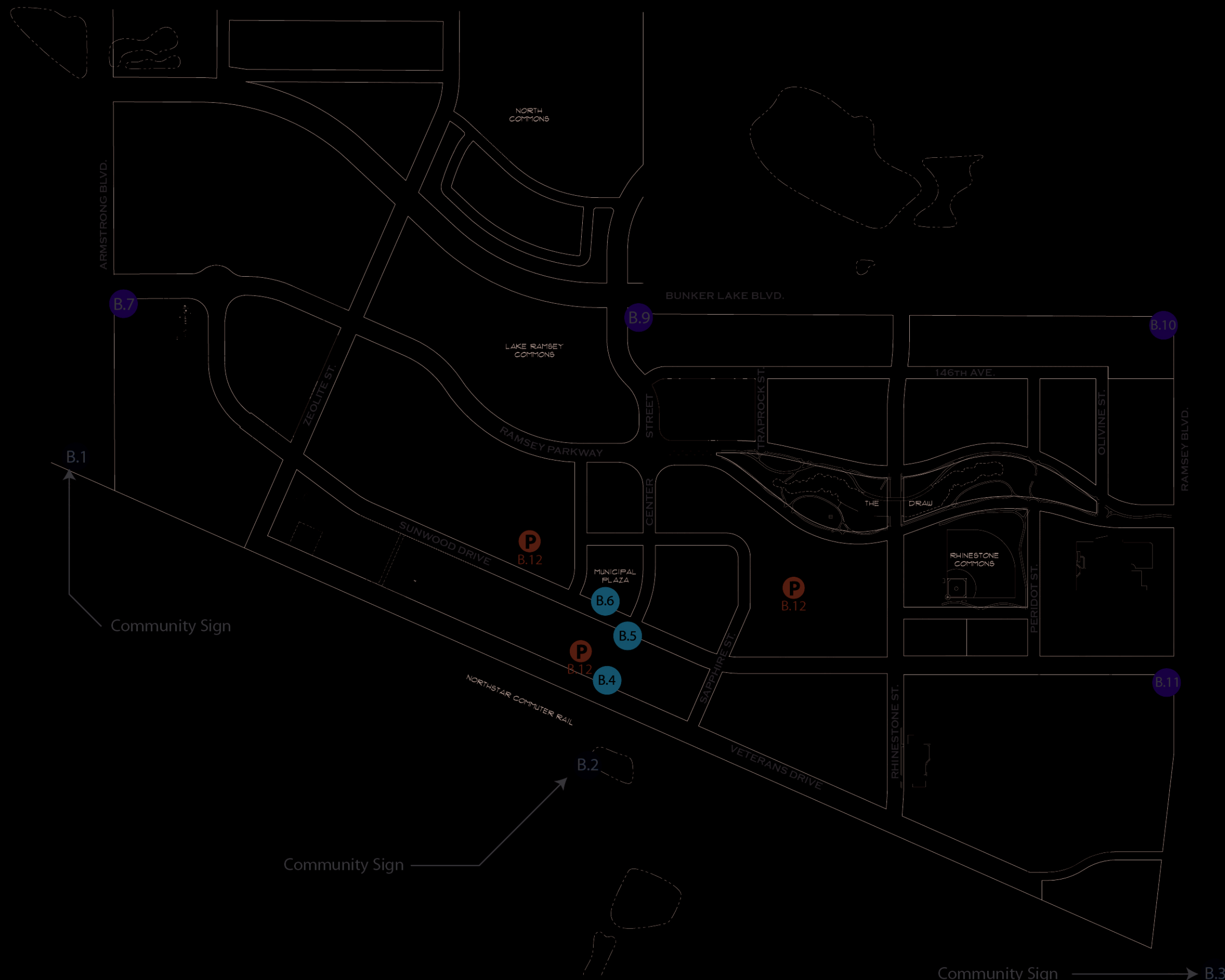

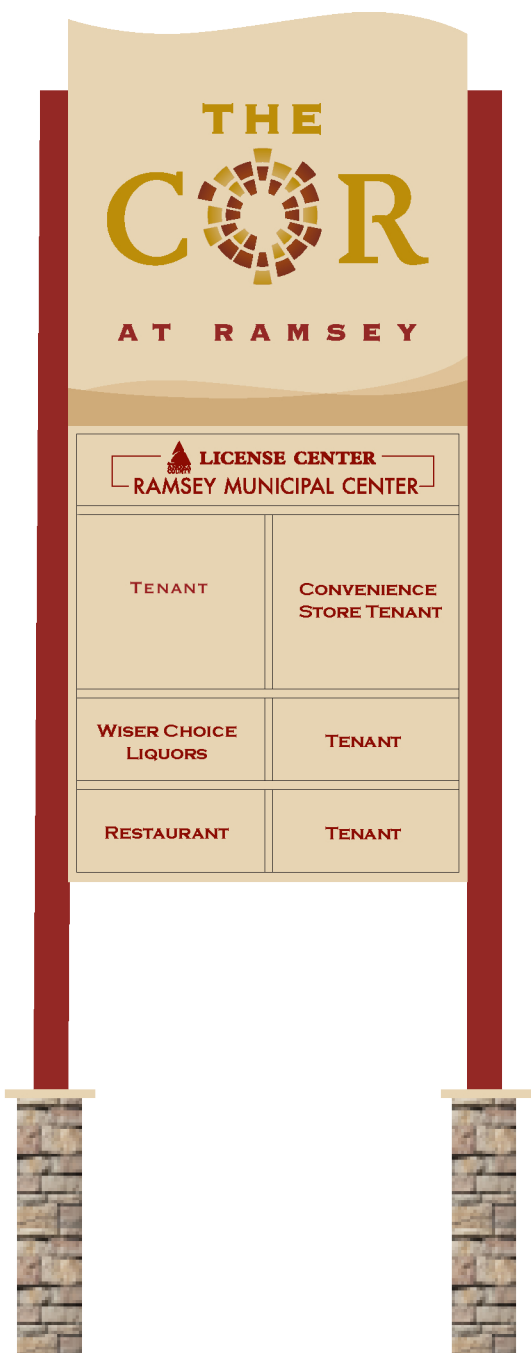

EXHIBIT B.1



Eastbound



Westbound

EXHIBIT B.2

LANDFORM
From Site to Finish

DESIGN FRAMEWORK
The COR at Ramsey
PYLON/COMMUNITY SIGN 'B'
Commuter Rail & Highway 10



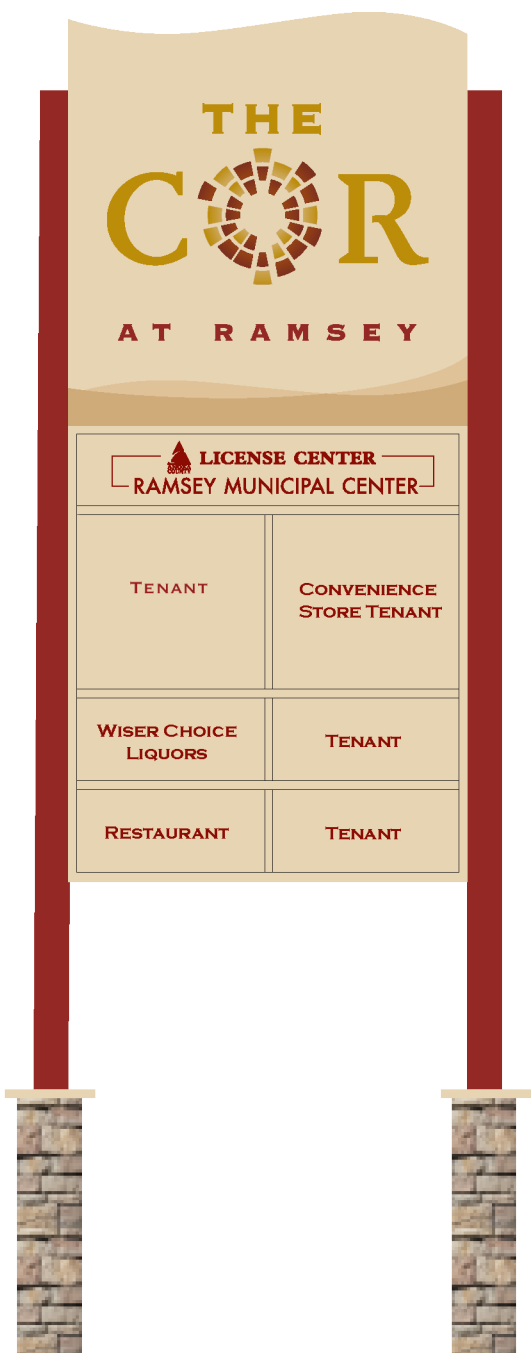

EXHIBIT B.3

●
●

L A N D F O R M

 From Site to Finish

DESIGN FRAMEWORK
 The COR at Ramsey
 PYLON/COMMUNITY SIGN 'C'
 Ramsey Blvd. & Highway 10



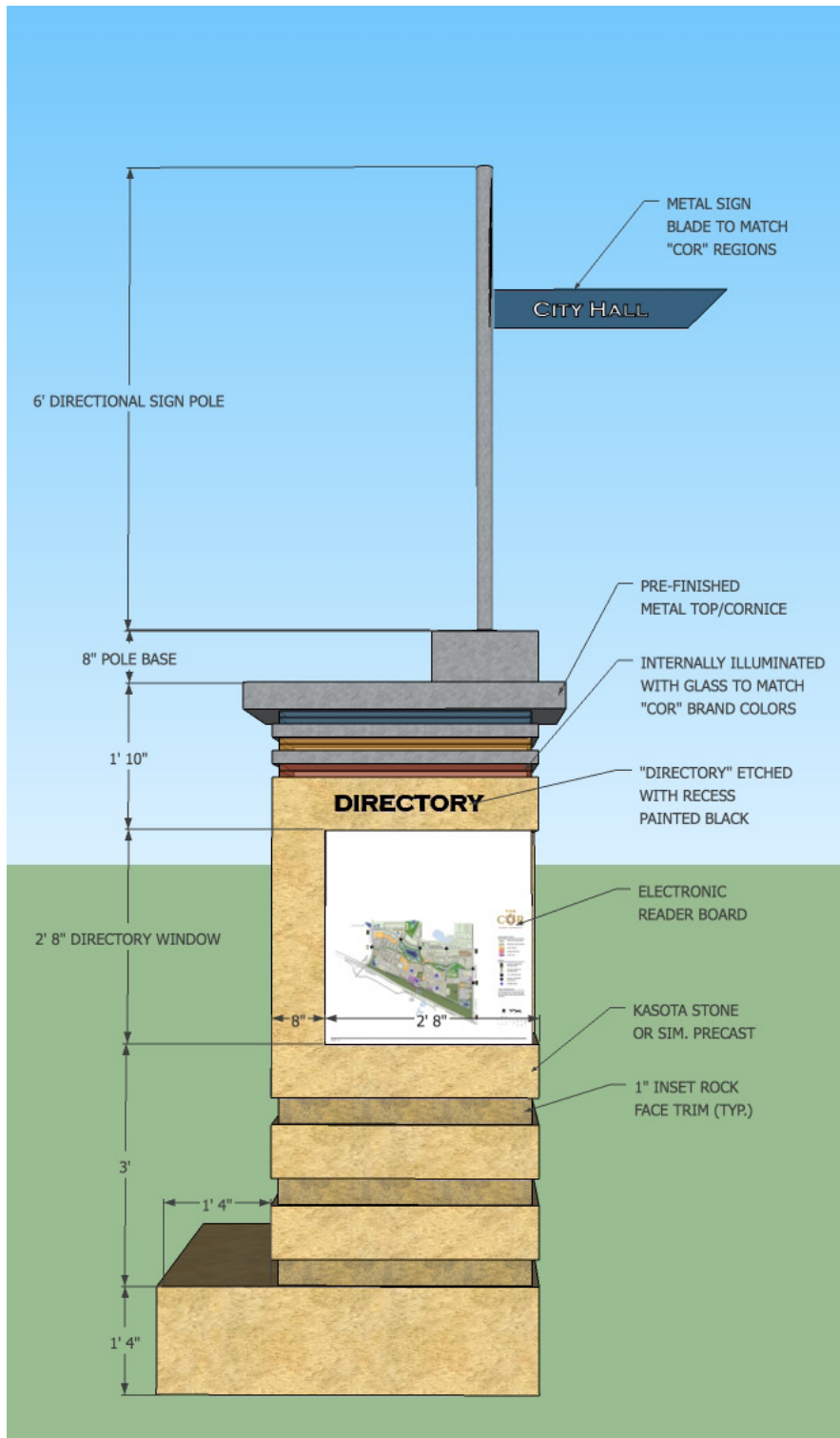

DIRECTORY PANEL VIEW



EVENTS PANEL VIEW

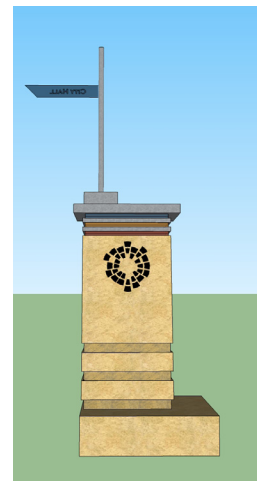

REAR VIEW

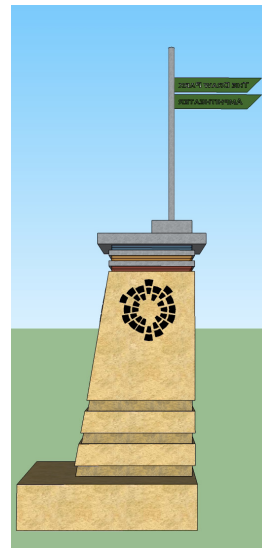

SIDE VIEW



PERSPECTIVE

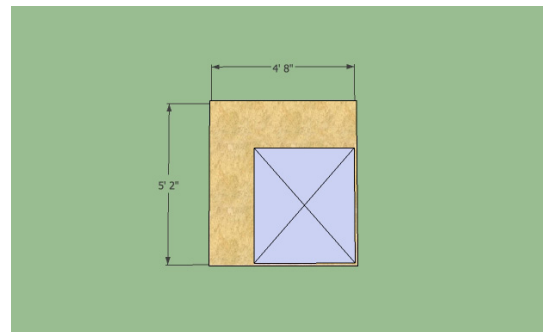

PLAN VIEW

EXHIBIT B.4

LANDFORM
From Site to Finish

DESIGN FRAMEWORK
The COR at Ramsey
COMMUNITY KIOSK 'A'
Commuter Rail & Veterans Dr.



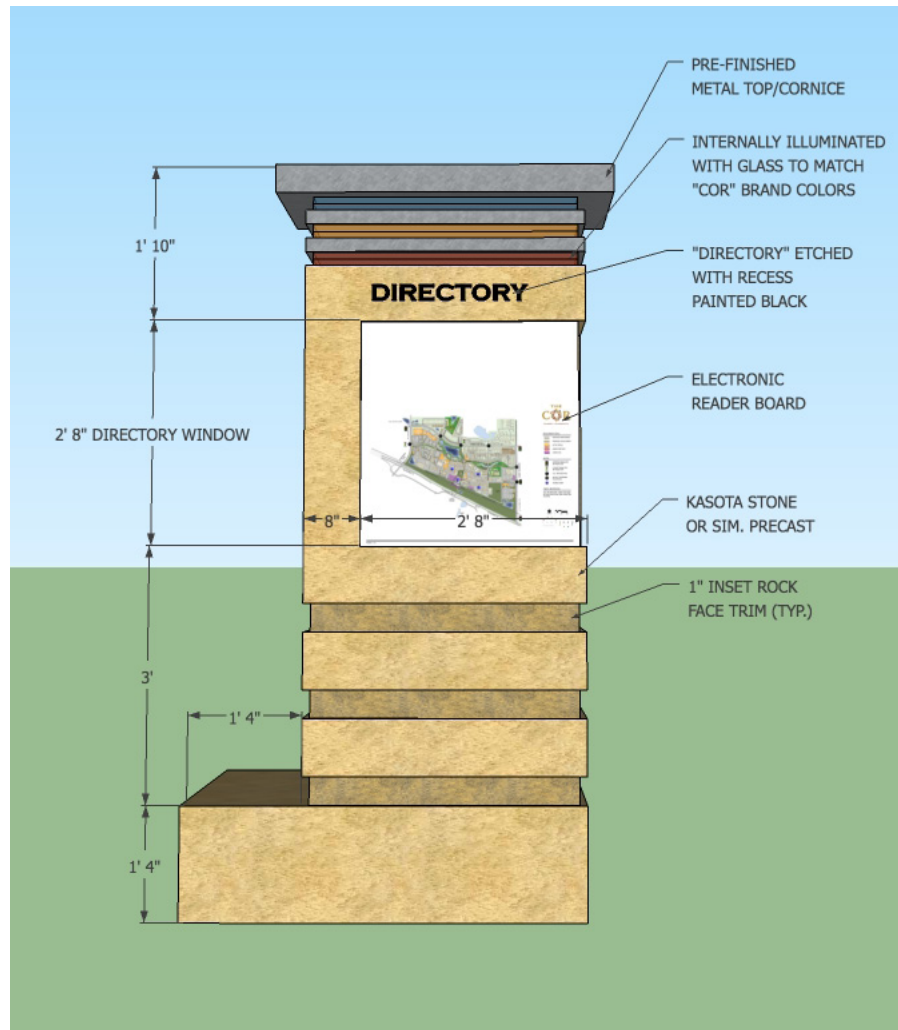

DIRECTORY PANEL VIEW



EVENTS PANEL VIEW

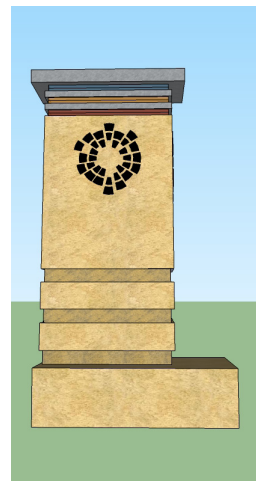

REAR VIEW

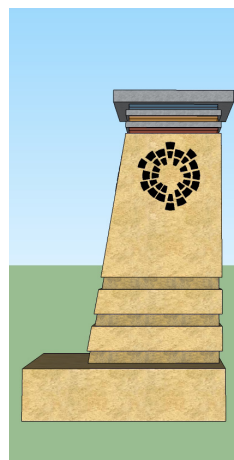

SIDE VIEW



PERSPECTIVE

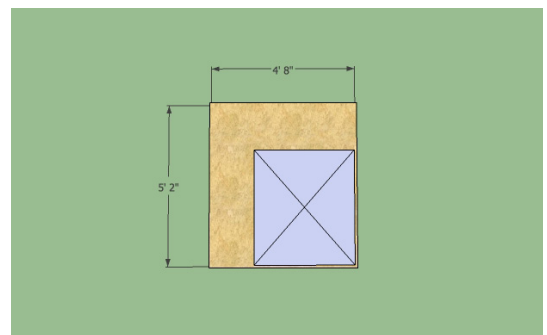

PLAN VIEW

EXHIBIT B.5

LANDFORM
From Site to Finish

DESIGN FRAMEWORK
The COR at Ramsey
COMMUNITY KIOSK 'B'
Sunwood Dr. & Center St.



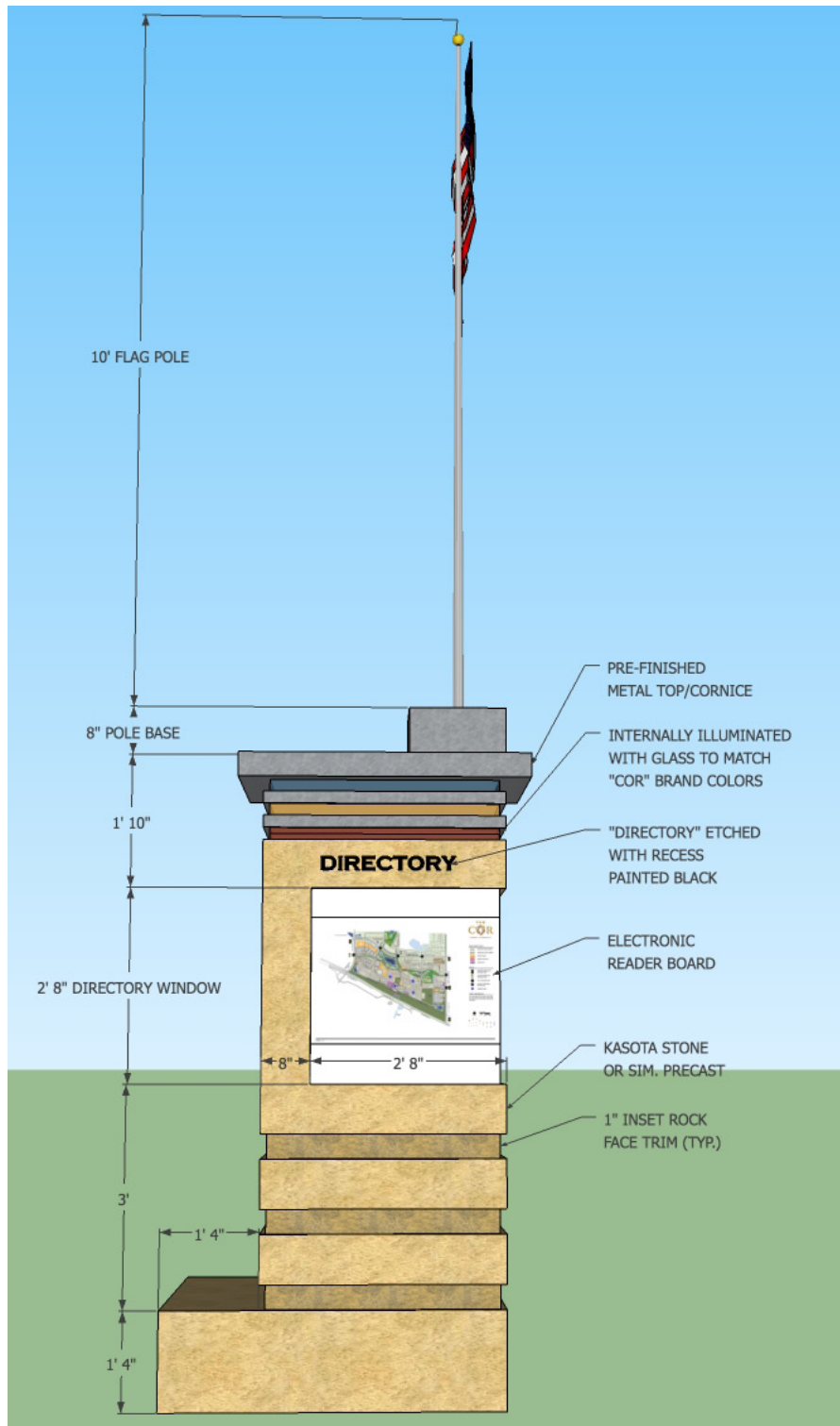

DIRECTORY PANEL VIEW

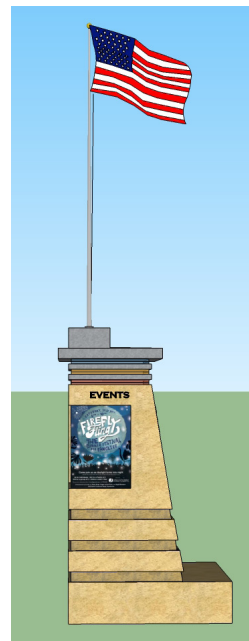

EVENTS PANEL VIEW

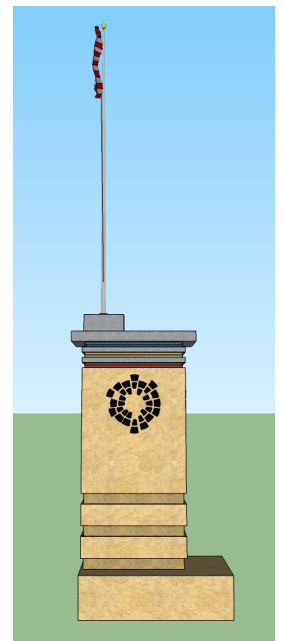

REAR VIEW

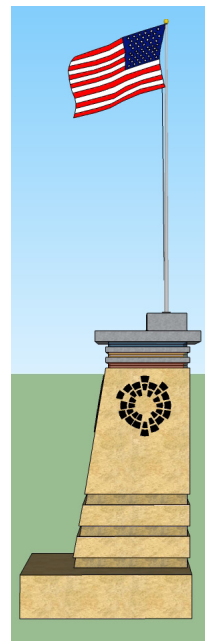

SIDE VIEW



PERSPECTIVE

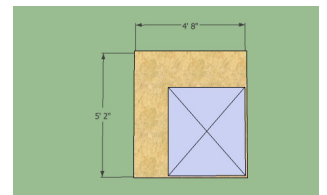

PLAN VIEW

EXHIBIT B.6

LANDFORM
From Site to Finish

DESIGN FRAMEWORK
The COR at Ramsey
COMMUNITY KIOSK 'C'
Sunwood Dr. at Municipal Plaza



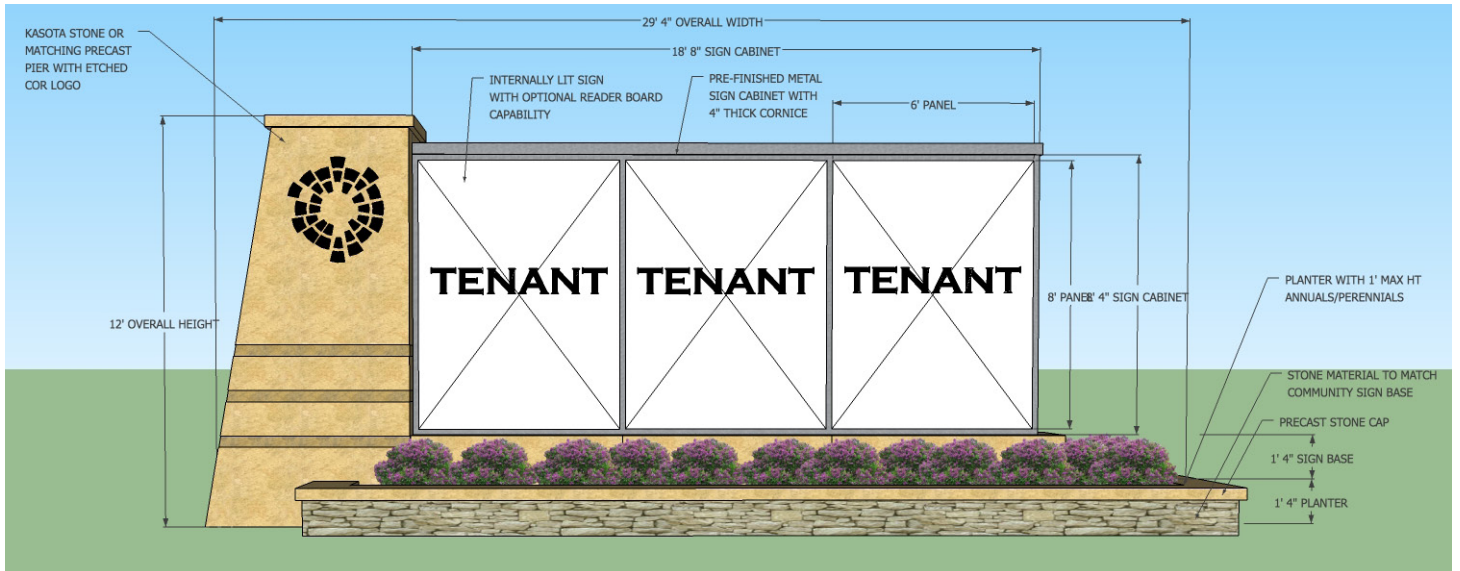

ELEVATION AT SUNWOOD

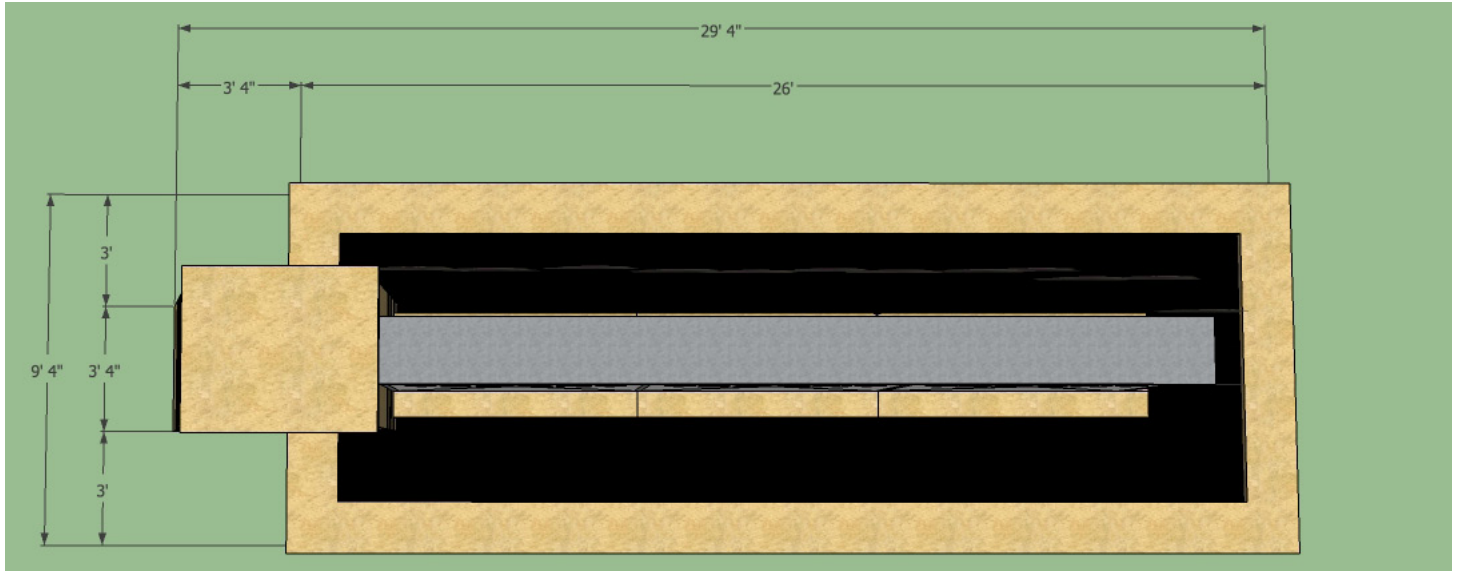

PLAN VIEW

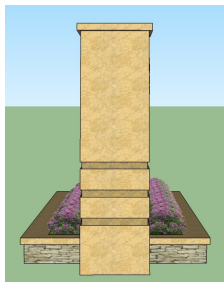

PROFILE VIEW

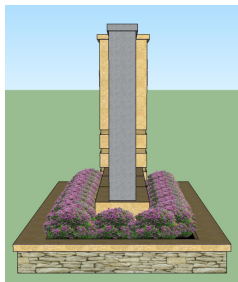

PROFILE VIEW

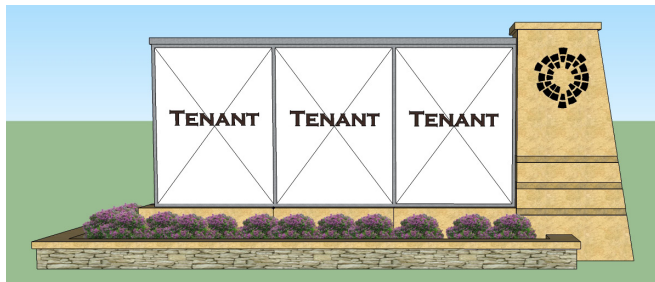

ELEVATION

EXHIBIT B.7



DESIGN FRAMEWORK
 The COR at Ramsey
 PROJECT GATEWAY SIGN 'A'
 Sunwood Dr. & Armstrong Blvd.



THIS PAGE LEFT INTENTIONALLY BLANK

EXHIBIT B.8



DESIGN FRAMEWORK
The COR at Ramsey



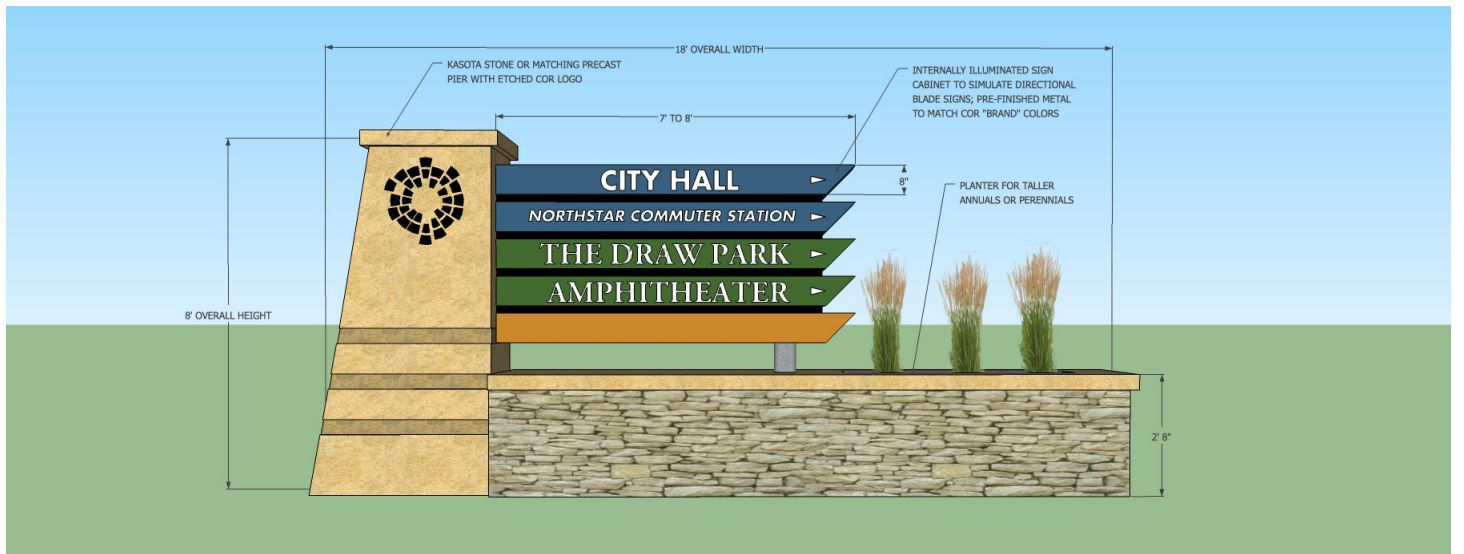

ELEVATION AT EASTBOUND BUNKER LAKE

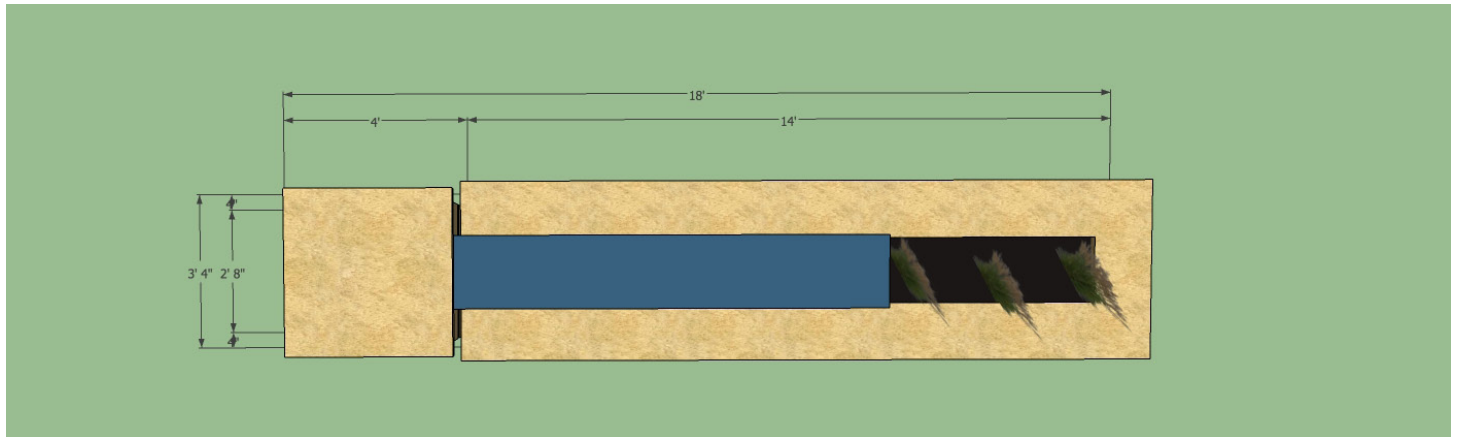

PLAN VIEW



PROFILE VIEW

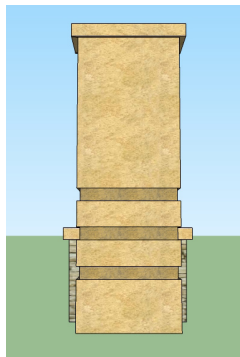

PROFILE VIEW



ELEVATION AT WESTBOUND BUNKER LAKE

EXHIBIT B.9

● ●
L A N D F O R M
 From Site to Finish

DESIGN FRAMEWORK
 The COR at Ramsey
 PROJECT GATEWAY SIGN 'C'
 Bunker Lake Blvd. & Center St.



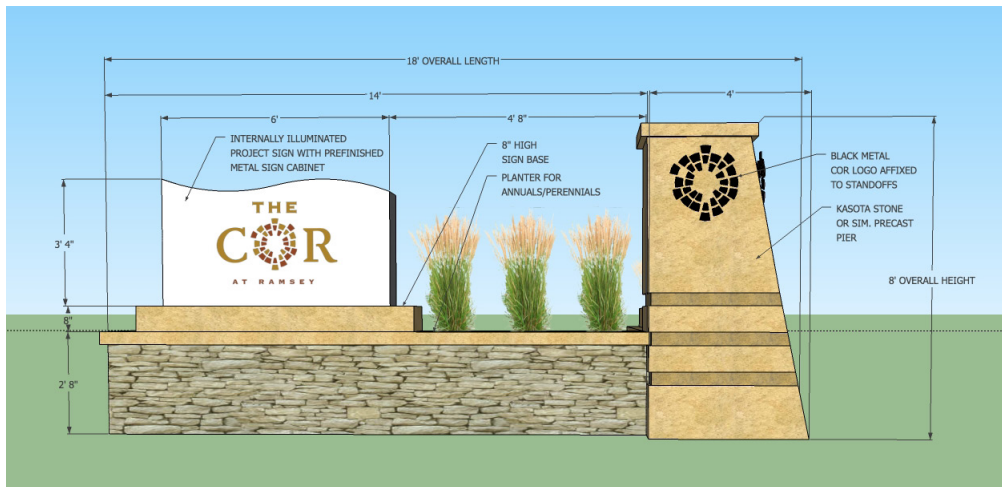

ELEVATION AT WESTBOUND BUNKER LAKE

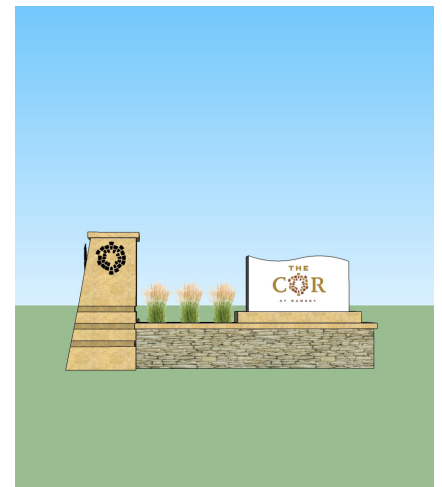

ELEVATION AT SOUTH BOUND RAMSEY

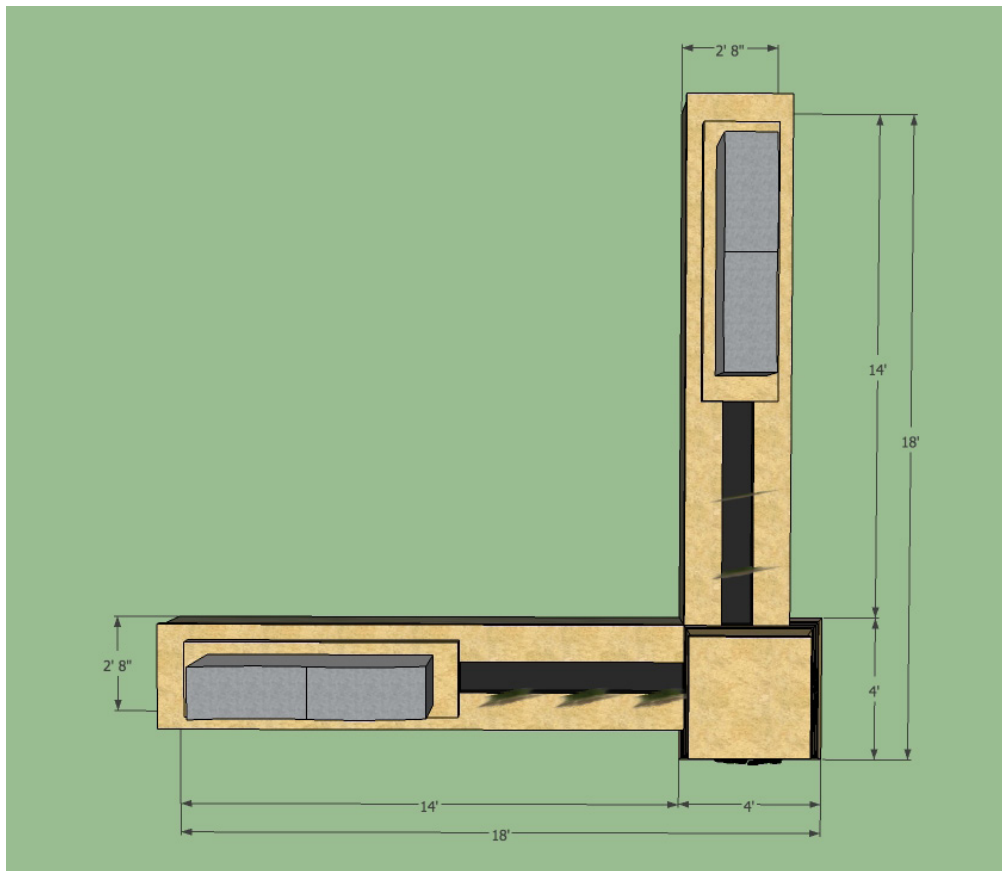

PLAN VIEW

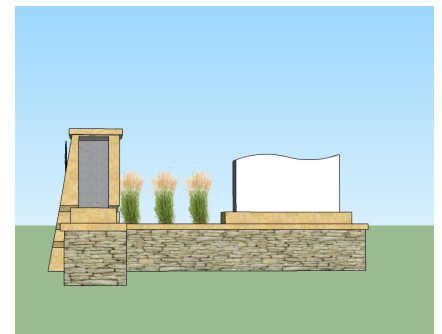

REAR PROFILE

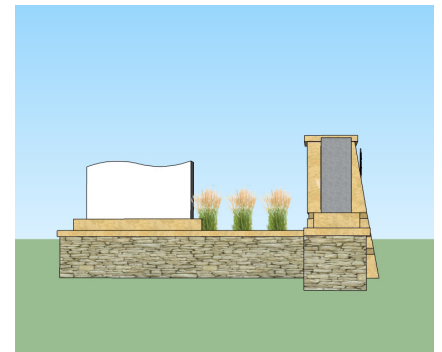

REAR PROFILE



PERSPECTIVE

EXHIBIT B.10

LANDFORM
From Site to Finish

DESIGN FRAMEWORK
The COR at Ramsey
PROJECT GATEWAY SIGN 'D'
Bunker Lake Blvd. & Ramsey Blvd.



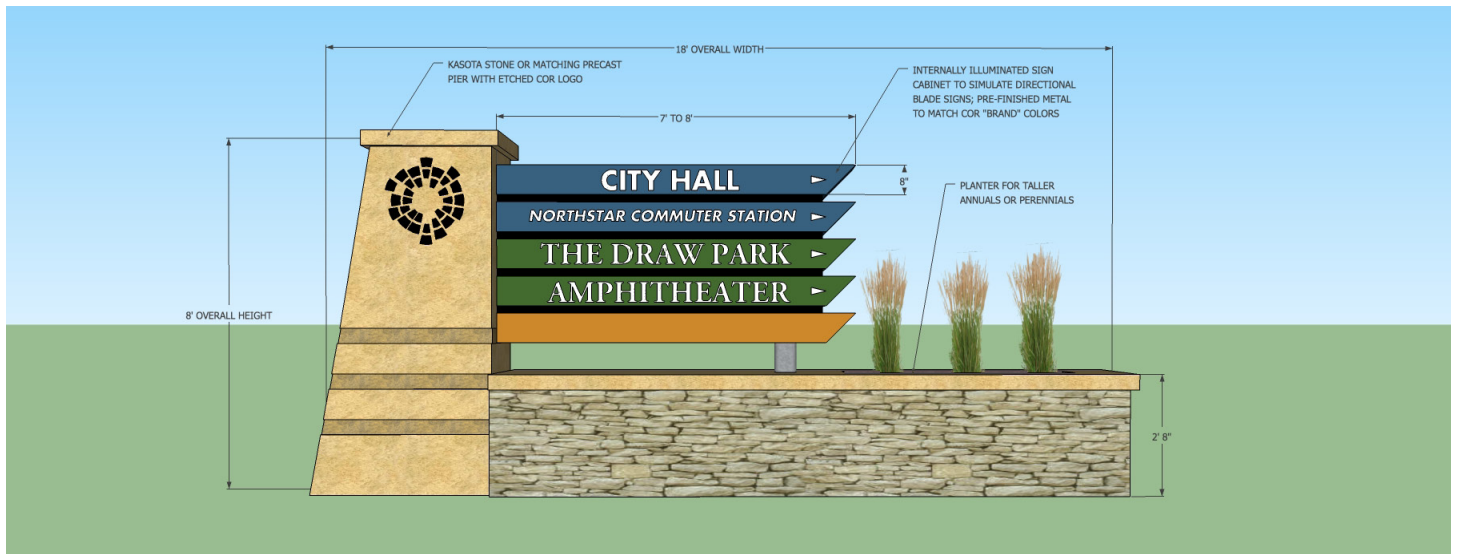

ELEVATION AT SOUTHBOUND RAMSEY

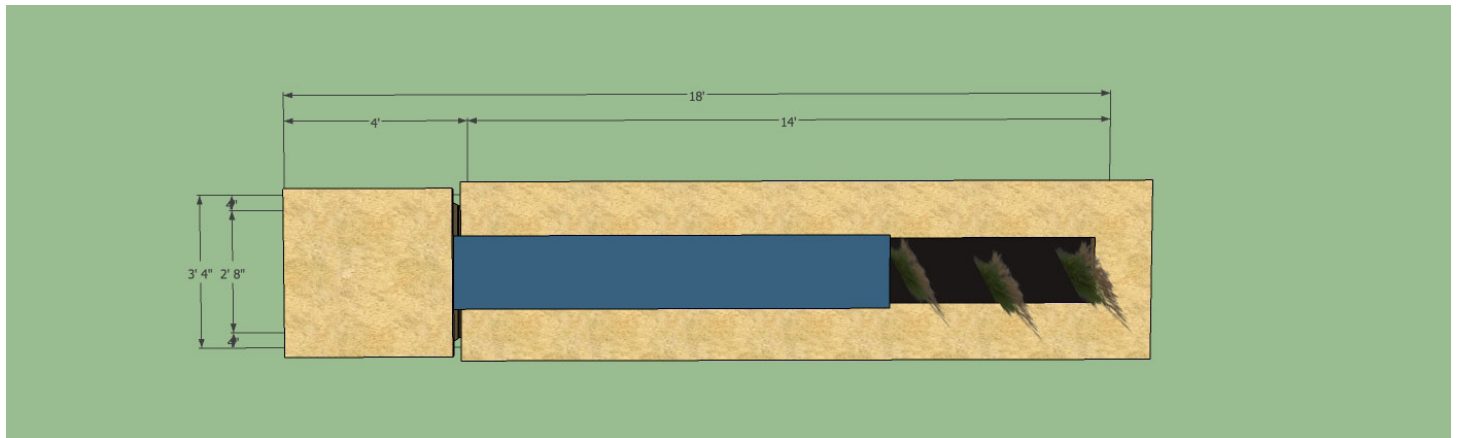

PLAN VIEW



PROFILE VIEW

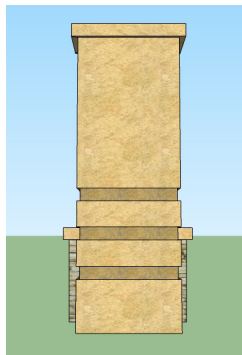

PROFILE VIEW



ELEVATION AT NORTHBOUND RAMSEY

EXHIBIT B.11

LANDFORM
From Site to Finish

DESIGN FRAMEWORK
The COR at Ramsey
PROJECT GATEWAY SIGN 'E'
Sunwood Dr. & Ramsey Blvd.



EXHIBIT B.12



DESIGN FRAMEWORK
The COR at Ramsey

PUBLIC PARKING SIGNAGE
Standard Signage



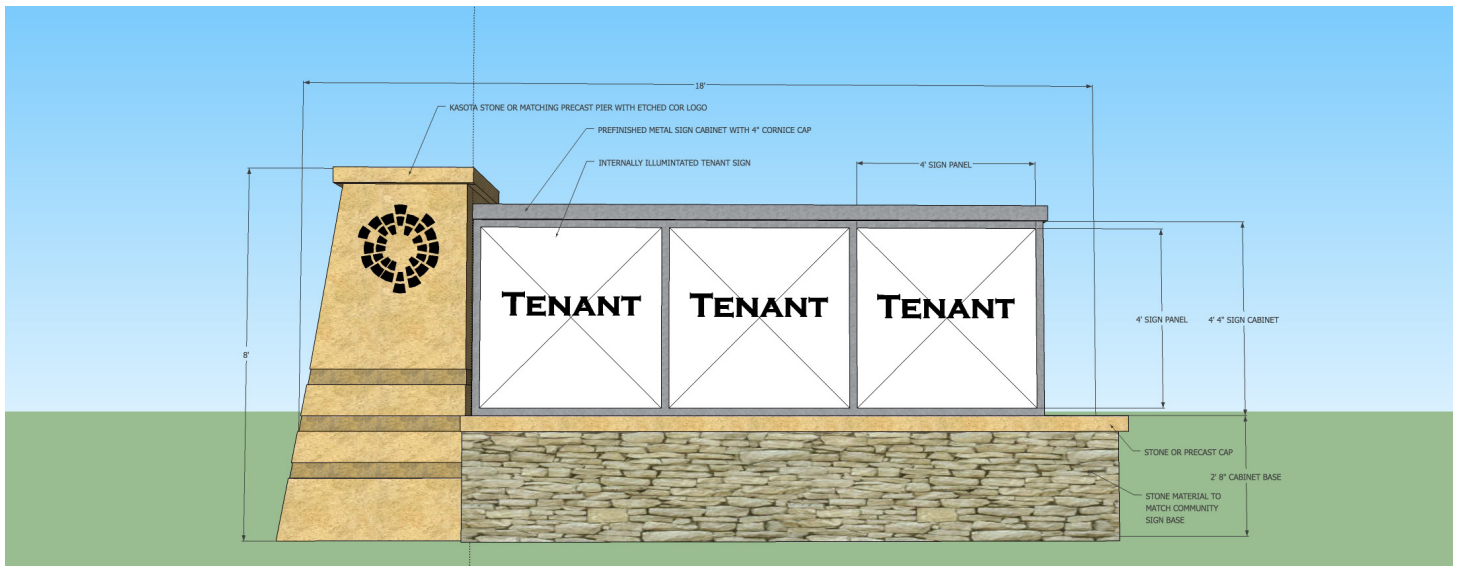

ELEVATION AT NORTHBOUND SUNWOOD

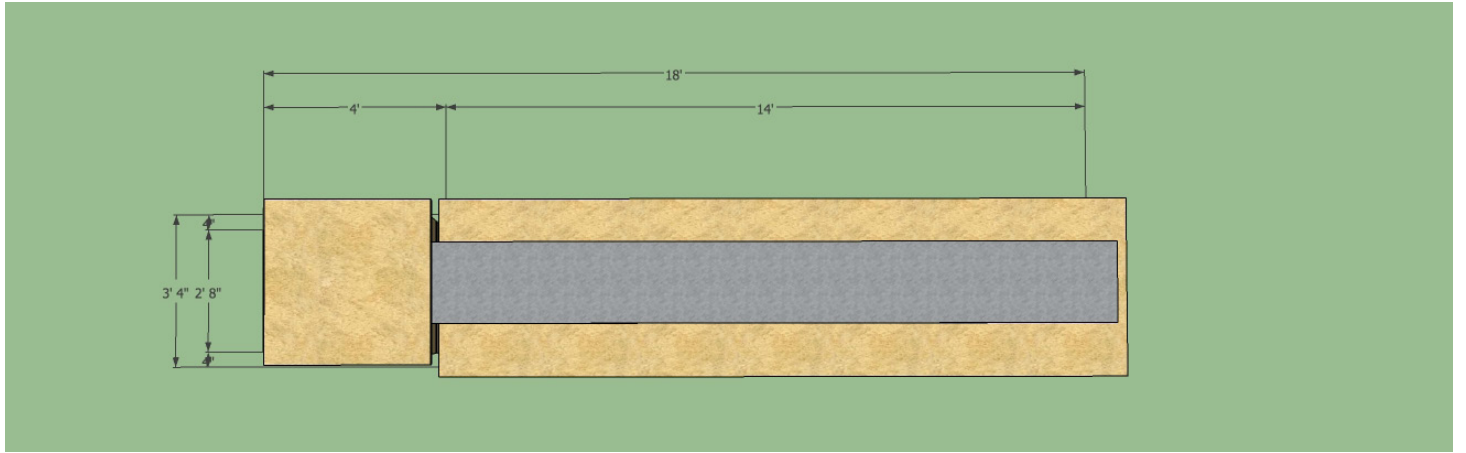

PLAN VIEW

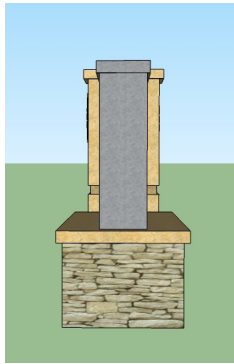

PROFILE VIEW

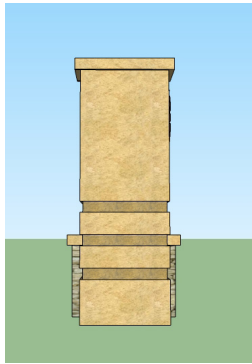

PROFILE VIEW

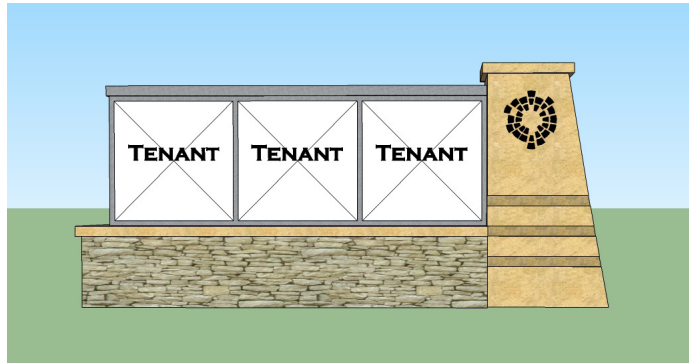

ELEVATION FROM SOUTHBOUND SUNWOOD

●
●

L A N D F O R M

 From Site to Finish

DESIGN FRAMEWORK
 The COR at Ramsey
 Multi-tenant Sign
 Sunwood Dr. & East COR II Entry

