

City of Ramsey
Agenda
Park and Recreation Commission
Thursday March 14, 2013
6:30 pm
Council Chambers, 7550 Sunwood Drive NW

- 1. Call to Order**
- 2. Citizen Input**
- 3. Approve Agenda**
- 4. Approve Minutes**
 1. Approve Park and Recreation Commission Meeting Minutes dated February 14, 2013.
- 5. Commission Business**
 1. Consider Park Land Dedication in Lieu of Cash Dedication for Future Development Adjacent to Lake Itasca
 2. Recommend Park Monuments for The Draw - 2013 Parks Capital Improvement
- 6. Commission/Staff Input**
 - 1. Commission/Staff Input**
 - Final 2012-13 Rink Patronage Count In: 5,953 persons counted at the warming houses - 3,085 at Central Park,
2,868 at Ramsey Elementary School (Use up *slightly* over preceeding winter)
 - Update on the status of various 2013 Parks Capital Improvements
 - April agenda items
- 7. Adjournment**

Park and Recreation Commission

4. 1.

Meeting Date: 03/14/2013

Submitted For: MaryJo Warner

By: MaryJo Warner, Engineering/Public Works

Information

Title:

Approve Park and Recreation Commission Meeting Minutes dated February 14, 2013.

Background:

The Park and Recreation Commission held its regular meeting on February 14, 2013.

Notification:

Observations/Alternatives:

Funding Source:

n/a

Staff Recommendation:

Action:

Motion to approve Park and Recreation Commission meeting minutes dated February 14, 2013.

Attachments

Minutes 02.14.13

Form Review

Inbox
Grant Riemer

Reviewed By
MaryJo Warner

Date
03/08/2013 02:25 PM
Started On: 03/08/2013 02:17 PM

Form Started By: MaryJo Warner

Final Approval Date: 03/08/2013

**PARK AND RECREATION COMMISSION
CITY OF RAMSEY
ANOKA COUNTY
STATE OF MINNESOTA**

The Ramsey Park and Recreation Commission conducted a regular meeting on Thursday, February 14, 2013, at the Ramsey Municipal Center, Ramsey, Minnesota.

Commission Members Present: Chairperson Melody Shryock
 Vice Chair Angela Olsen
 Commissioner Bridgett Barr
 Commissioner Shane Bennett
 Commissioner Andrew Fyten
 Commissioner David Minke

Commission Members Absent: Commissioner Richard Chubb (excused)

Also Present: Parks & Assistant Public Works Superintendent Mark Riverblood

1. CALL TO ORDER

Chairperson Shryock called the Park and Recreation Commission meeting to order at 6:30 p.m.

2. CITIZEN INPUT

None.

3. APPROVE AGENDA

Motion by Commissioner Olsen, seconded by Commissioner Barr to approve the Park and Recreation Commission meeting agenda as presented.

Motion carried. Voting Yes: Chairperson Shryock, Commissioners Olson, Barr, Bennett, Fyten, and Minke. Voting No: None. Absent: Commissioner Chubb.

4. APPROVE MINUTES

4.01: Approve Park and Recreation Commission Meeting Minutes dated January 10, 2013

Motion by Commissioner Minke, seconded by Commissioner Fyten, to approve the following Park and Recreation Commission Regular Meeting Minutes:

- 1) Park and Recreation Commission Regular Meeting Minutes dated January 10, 2013.

Motion carried. Voting Yes: Chairperson Shryock, Commissioners Minke, Fyten, Barr, Bennett, and Olsen. Voting No: None. Absent: Commissioner Chubb.

5. COMMISSION BUSINESS

5.01: Recommend the Decommission of Titterud Park's Tennis Court.

Parks & Assistant Public Works Superintendent Riverblood noted one of the City's first improved parks was Titterud Park. In the late 1970's several improvements occurred in the park, including the installation of a two-court tennis court (with lights being added later). The courts have been color-coated several times over the decades and in 2007, staff routed the significant vertical cracks in the court and patched with bituminous in an attempt to extend the courts useful life. This did extend the time the courts could be used for play for a short while until the color-coating began to spall off in increasingly larger pieces. In the Spring of 2012, staff inspected the courts and deemed them no longer safe for play and did not install nets.

Parks & Assistant Public Works Superintendent Riverblood reported shortly after the courts were deemed unsafe for play. Staff posted a notice at the entrance asking potential patrons to contact staff if they had questions or concerns with the court's closure. Two inquiries were received from residents and they were directed to the other tennis courts in the City.

Parks & Assistant Public Works Superintendent Riverblood explained that replacement of the courts would cost a minimum of \$50,000. The City also has four courts at Rivers' Bend Park, four at Central Park, and a single court each at Riverdale and Fox Parks. The primary users of these tennis courts at Rivers' Bend and Central are seniors.

Riverblood continued that the removal of the courts and recycling of the materials can be performed in-house with Public Works Staff as time permits. The lighting relocation from Titterud Park to Central Park is being investigated. No supplemental funding is required at this time as the equipment and trucking time to remove the courts would be absorbed by the Parks operating budget. Funding for the relocation of the lights will be addressed separately, if found to be feasible. Staff recommends that the tennis courts at Titterud Park be removed and disposed of, as appropriate, and to look at relocating the lighting system. This would cost approximately \$8,000. Parks & Assistant Public Works Superintendent Riverblood stated he does not believe tennis play is increasing in the City at this point in time nor nationally as a trend.

Chairperson Shryock asked what the \$8,000 cost to move the lighting consisted of.

Parks & Assistant Public Works Superintendent Riverblood reviewed what was entailed in moving the lighting. One question is whether the lighting for a two-court system would be able to light a four-court system. It is staff's belief it would and staff will look at using the same power supply as used by the hockey rink lights; however, more cable will be needed.

Commissioner Bennett asked what the cost would be for the removal of the fencing.

Parks & Assistant Public Works Superintendent Riverblood stated staff would remove the fencing and the bituminous would be hauled away. Any equipment that could be salvaged would be salvaged and the remainder would be scrapped.

Commissioner Barr asked if putting a volleyball area in place of the tennis courts was considered.

Parks & Assistant Public Works Superintendent Riverblood stated a volleyball court may be better suited in a park with bathroom facilities.

Chair Shryock asked if the existing fencing would remain when the tennis courts are removed to ensure safety on the construction site.

Parks & Assistant Public Works Superintendent Riverblood stated he has not considered the details of security that as of yet, however, public safety is always the first priority in project planning.

Motion by Commissioner Barr, seconded by Commissioner Olsen, to recommend to the City Council that the tennis courts at Titterud Park be removed and disposed of as may be appropriate.

Motion carried. Voting Yes: Chairperson Shryock, Commissioners Barr, Olsen, Bennett, Fyten, and Minke. Voting No: None. Absent: Commissioner Chubb.

6. COMMISSION/STAFF INPUT

6.01: Commission/Staff Input

Parks & Assistant Public Works Superintendent Riverblood stated he had hoped to provide a report on skating rink usage but the usage numbers were not yet available due to a staff member's vacation. He stated the ice is skateable and is being used.

Commissioner Barr thanked staff for their work on the skating rinks.

Commissioner Minke asked if there was any feedback on the capital improvement meeting held.

Parks & Assistant Public Works Superintendent Riverblood stated the meeting went very well and lasted approximately one and a half hours. It was found the best method was to provide a group of choices. He suggested a subcommittee be formed from the Commission to investigate options for Elmcrest Park's playground project.

Parks & Assistant Public Works Superintendent Riverblood led a discussion on a Subcommittee to Refine Components/Theme for Elmcrest Park's Playground.

Commissioners Bennett and Olsen offered to serve on the subcommittee.

Parks & Assistant Public Works Superintendent Riverblood stated it might take a month or so to get to the point where the subcommittee would start their work. There was discussion about

locations of the concession plan, building orientation, pedestrian traffic flow, containment border. It was noted that \$75,000 will be invested in the project. Inquiries have been received from residents on the other side of Highway 47 about the park.

Chair Shryock suggested boulders be added to the park.

Parks & Assistant Public Works Superintendent Riverblood stated the boulders fit well in these projects and a lot of play is done on the boulders.

Chair Shryock stated another park spot this week was recorded and a winter edition was done featuring cross country skiing and skating. She stated trails continue to be groomed within the City.

Parks & Assistant Public Works Superintendent Riverblood stated the trails are plowed as soon as possible after a weather incident. He stated the sliding hill at Alpine Park is being utilized regularly and noted the North Commons sliding hill is also being used.

7. ADJOURNMENT

Motion by Commissioner Bennett, seconded by Commissioner Minke, to adjourn the meeting.

Motion carried. Voting Yes: Chairperson Shryock, Commissioners Bennett, Minke, Barr, Fyten, and Olsen. Voting No: None. Absent: Commissioner Chubb.

The Park and Recreation Commission meeting adjourned at 6:50 p.m.

Respectfully submitted,

Mark Riverblood
Parks & Assistant Public Works Superintendent

Drafted by Debbie Wolfe
TimeSaver Off Site Secretarial, Inc.

Meeting Date: 03/14/2013

By: Mark Riverblood, Engineering/Public Works

Information

Title:

Consider Park Land Dedication in Lieu of Cash Dedication for Future Development Adjacent to Lake Itasca

Background:

In 1987 a Planned Unit Development was approved known as North Fork. As part of the phases of the platting, and by mutual agreement, two outstanding Park Dedication matters remain from those lands that have already been subdivided. These are that North Fork Inc. (the Developer) 'owes' the City two acres of quality park land, and also 'owes' a 50' foot wide easement to access the presently undeveloped park tracts east of Lake Itasca and generally north of Outlot E. The 50' access dedication is understood to be over or across Outlot E.

Attached as 'North Fork Subdivision Key' are those parcels labeled as referenced within this case.

Notification:

Observations/Alternatives:

The purpose of this case is to receive the Commission's *general* position on exploring park land dedication (over and above what may be owed), in lieu of cash dedication for that undeveloped parcel south of Alpine Drive entitled 'Proposed Future Development' on the attachment. This land at this time, is expected to permit approximately 16 single family homes.

There are many variables and considerations that also may enter into the question above, however this case is only intended to address the general position, as a beginning point of discussion between the Developer and the City. It should be noted that the Developer is seeking to answer this question for their planning purposes, and thus the timing of this case.

While the Developer may also be interested in receiving Park Dedication credit for the dedication of land involving Outlot C and Outlot D (Moors), Staff is not recommending that they be considered, or if ultimately they are a part of some equation, that it be ancillary to receiving Outlot E.

More information and background will be available at the meeting and based upon discussion.

Funding Source:

No funding considerations are germane at this time, relating to the question of land versus cash Park Dedication in the matter of North Fork Inc. and the City.

Staff Recommendation:

A Staff's recommendation would be to remain amenable to North Fork Inc.'s request to explore any number of formulas for meeting present and future Park Dedication owed.

Action:

Motion to recommend to City Council that Staff work with North Fork Inc. to present options to solve the present and future Park Dedication owed.

Attachments

North Fork Subdivision Key

Form Review

Inbox
Grant Riemer

Reviewed By
Grant Riemer

Date
03/08/2013 03:50 PM
Started On: 03/07/2013 12:30 PM

Form Started By: Mark Riverblood

Final Approval Date: 03/08/2013

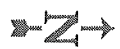
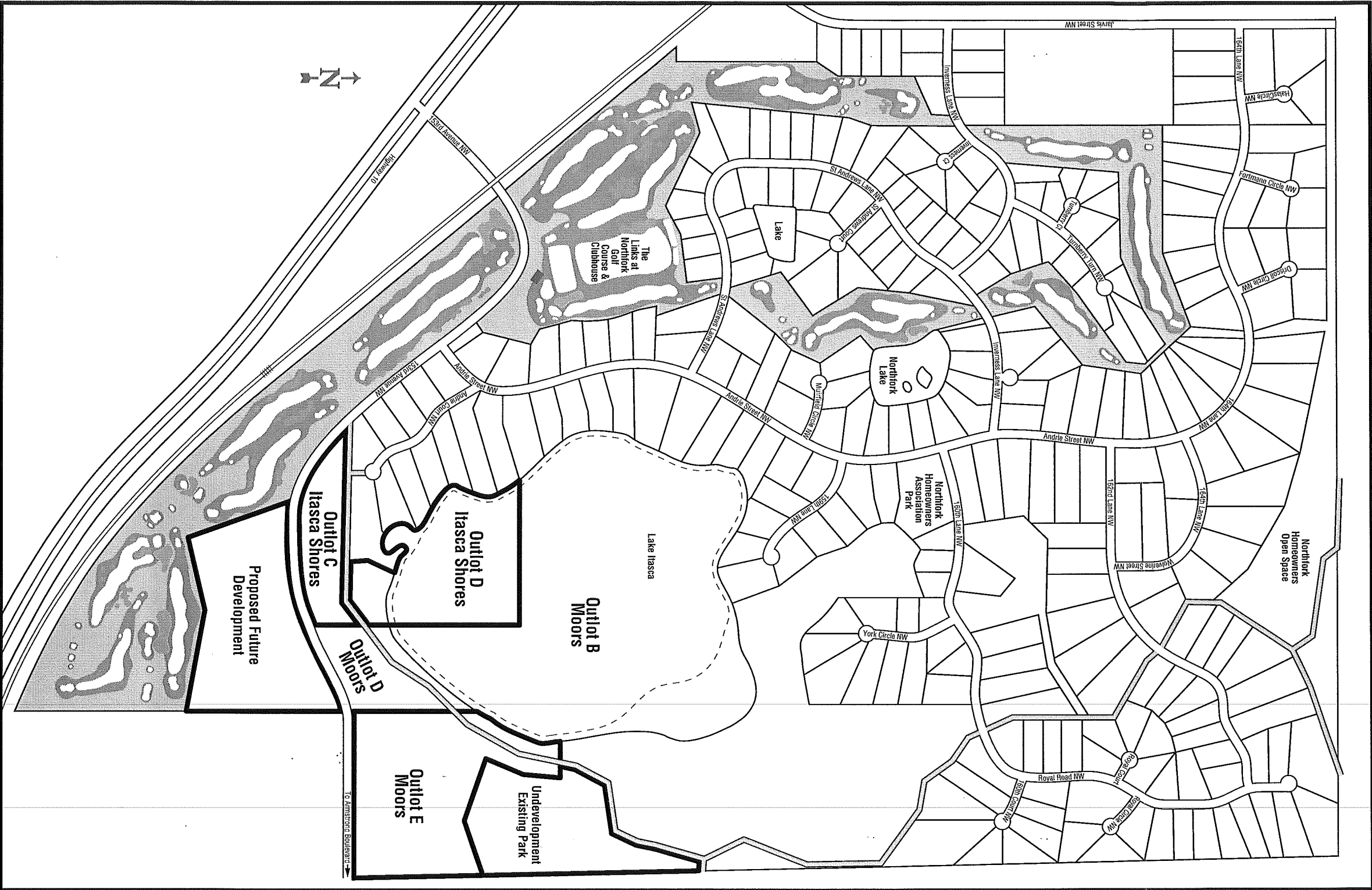

The Links at Northfork Golf Course & Clubhouse

Lake

Northfork Lake

Lake Hasca

Northfork Homeowners Association Park

Northfork Homeowners Open Space

Proposed Future Development

Outlet C Itasca Shores

Outlet D Itasca Shores

Outlet B MOORS

Outlet D MOORS

Outlet E MOORS

Undevelopment Existing Park

10 ARMSTRONG BOULEVARD

Jarvis Street NW

14th Lane NW

Fortmann Circle NW

Haselgrove NW

St Andrews Lane NW

Northfork Circle NW

York Circle NW

Royal Road NW

St Andrews Lane NW

Andrie Street NW

14th Lane NW

12th Lane NW

10th Lane NW

14th Lane NW

12th Lane NW

10th Lane NW

Viking Street NW

Royal Road NW

Royal Road NW

Royal Road NW

14th Lane NW

12th Lane NW

10th Lane NW

York Circle NW

Royal Road NW

Royal Road NW

15th Avenue NW

13th Avenue NW

11th Avenue NW

9th Avenue NW

7th Avenue NW

5th Avenue NW

3rd Avenue NW

1st Avenue NW

15th Lane NW

13th Lane NW

11th Lane NW

9th Lane NW

7th Lane NW

5th Lane NW

3rd Lane NW

1st Lane NW

15th Lane NW

13th Lane NW

Park and Recreation Commission

5. 2.

Meeting Date: 03/14/2013

By: Mark Riverblood, Engineering/Public Works

Information

Title:

Recommend Park Monuments for The Draw - 2013 Parks Capital Improvement

Background:

On February 5th, 2013, the Park and Recreation Commission met with City Council in a joint work session for the purposes of a preview of the 2013 Parks Capital Improvement Program (CIP). Consensus was *generally* that most projects should move forward as discussed within the CIP document.

However, considerable discussion ensued regarding the two park entrance monuments (signs) for The Draw. Discussion may be summarized between two views:

One shared by a couple Council members was that park signage need not cost several 10's of thousands of dollars. Another position iterated was that these are indeed way-finding monuments, and are also expected to be in service for many decades - and should be constructed in a manner that befits the 3 million dollar investment that represents the 7-acre park's construction cost. (It may also be noted that the entrance monument at Central Park cost approximately \$50,000 in 1997.)

Notification:

Observations/Alternatives:

The purpose of this case is to further the discussion on the scope and cost of the proposed 2013 monuments for The Draw. Several documents are attached to aid in the discussion:

- The COR sign design guidelines approved by City Council in December 2012
- Exhibit showing the two monument or sign locations for The The Draw
- 'Cadillac' monument cost
- 'Chevrolet' monument cost
- 'Metro Geo' monument cost

Staff requested three estimates from sign maker Archetype from Minneapolis (based upon the approved COR sign guidelines), in three quality/cost 'levels' fondly referred to herein as the 'Cadillac', 'Chevrolet' and 'Geo Metro' for descriptive purposes. While the price points are outlined in the attachments, Staff does not have a perspective view to compare these choices to, but has asked the vendor to prepare these **to be available for the meeting**.

It may also be noted that the intent for this element of the Parks CIP would be to have these installed if possible in time for the The Draw Summer Concert Series beginning June 20th. (Attached also for your information is the summer schedule of events.)

Funding Source:

The funding source is presently shown as \$20,000 within the 2013 Parks CIP from the Park Improvement Trust Fund.

Staff Recommendation:

A Staff recommendation is pending the examination of the perspective views of the three categories of monument choices, together with an investigation of materials and durability and utility.

Action:

Motion to recommend to City Council a level of scope and cost for the two monuments and way-finding signs for The Draw, based upon discussion.

Attachments

The COR Sign Plan

The Draw Location styles

Metro Geo

chevy

caddy

The Draw Events 2013

Form Review

Inbox
Grant Riemer

Reviewed By
Grant Riemer

Date
03/08/2013 12:17 PM
Started On: 03/07/2013 12:33 PM

Form Started By: Mark Riverblood

Final Approval Date: 03/08/2013



EXHIBIT B.1



Eastbound

Westbound

EXHIBIT B.2

●
●

L A N D F O R M

 From Site to Finish

DESIGN FRAMEWORK
The COR at Ramsey
 PYLON/COMMUNITY SIGN 'B'
Commuter Rail & Highway 10





EXHIBIT B.3

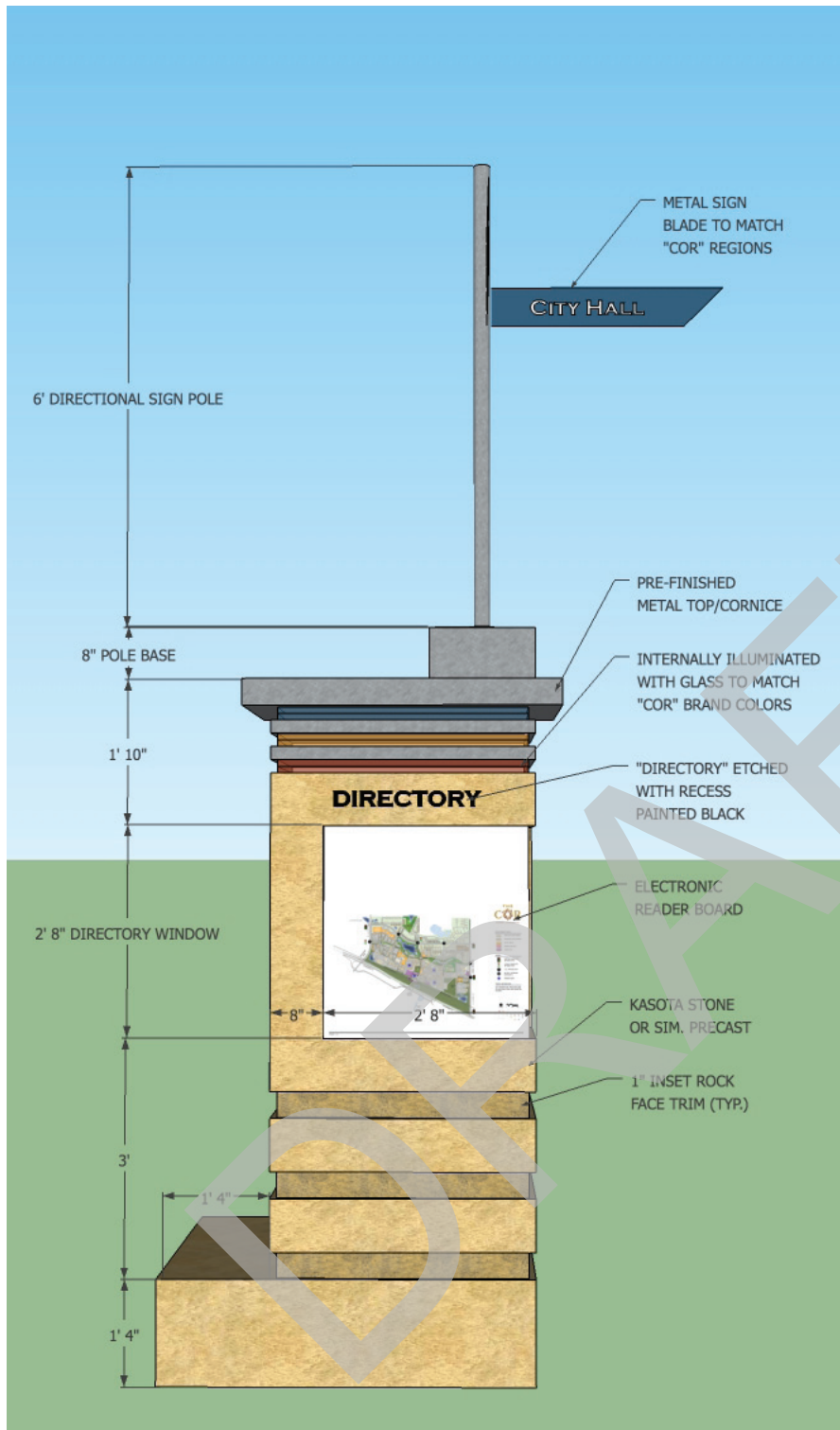

DIRECTORY PANEL VIEW



EVENTS PANEL VIEW

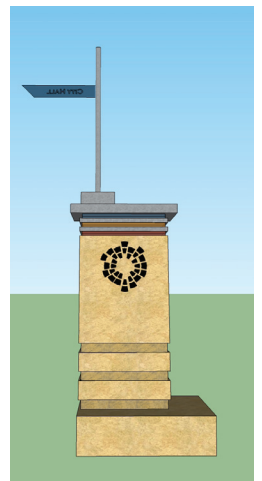

REAR VIEW

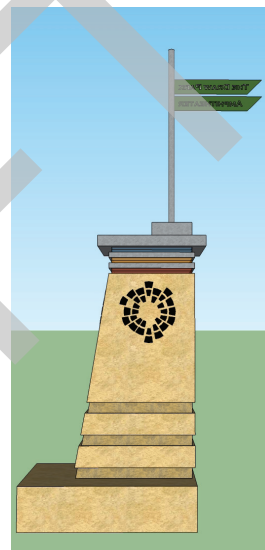

SIDE VIEW



PERSPECTIVE

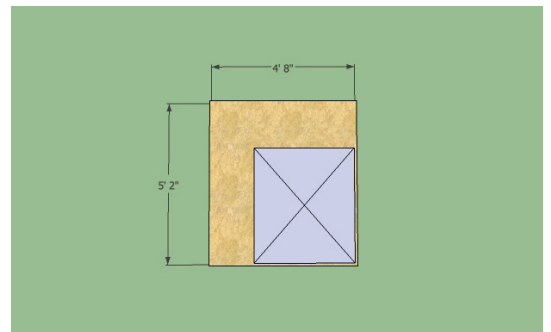

PLAN VIEW

EXHIBIT B.4

LANDFORM
From Site to Finish

DESIGN FRAMEWORK
The COR at Ramsey
COMMUNITY KIOSK 'A'
Commuter Rail & Veterans Dr.



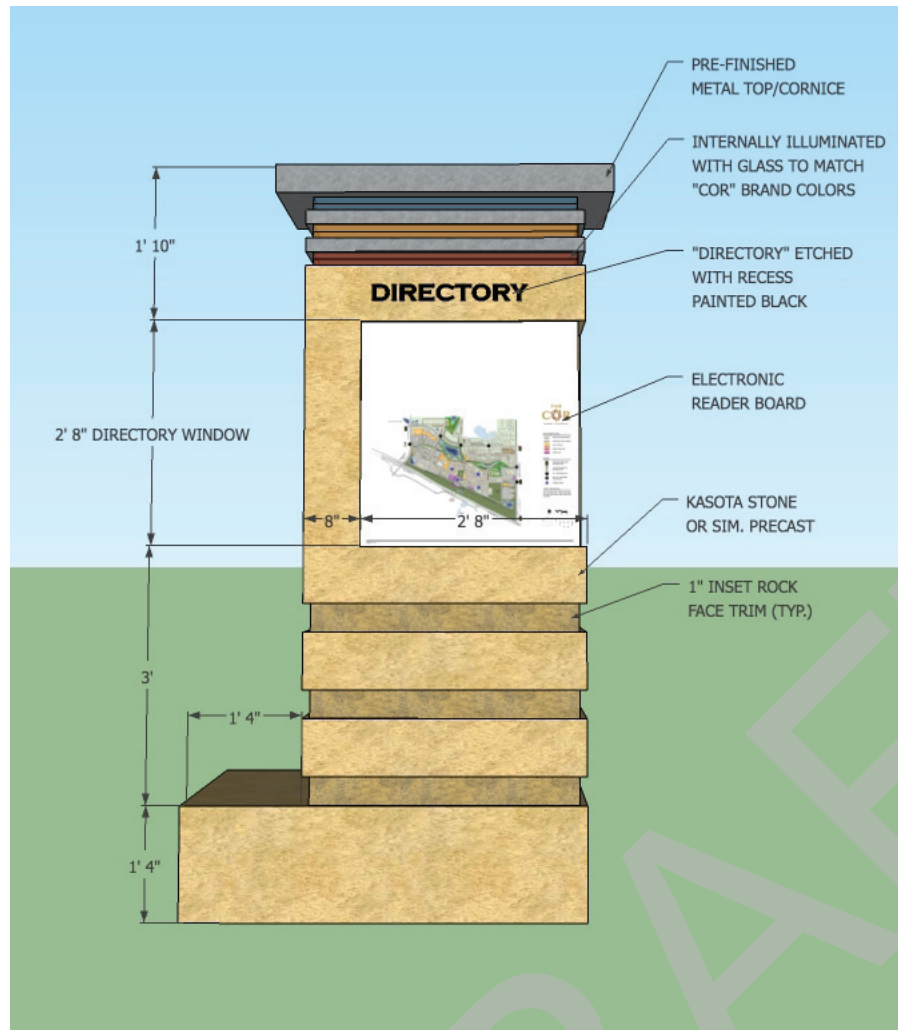

EVENTS PANEL VIEW

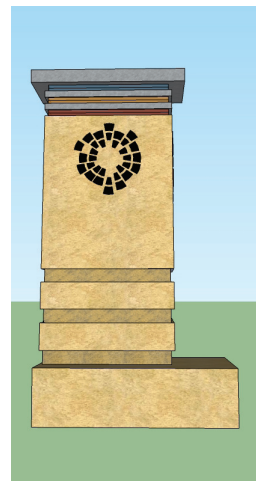

REAR VIEW

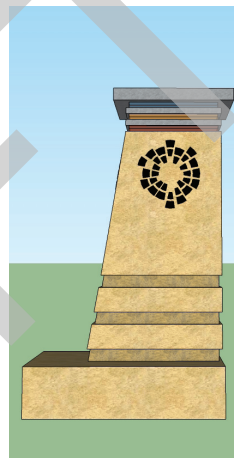

SIDE VIEW



PERSPECTIVE

DIRECTORY PANEL VIEW

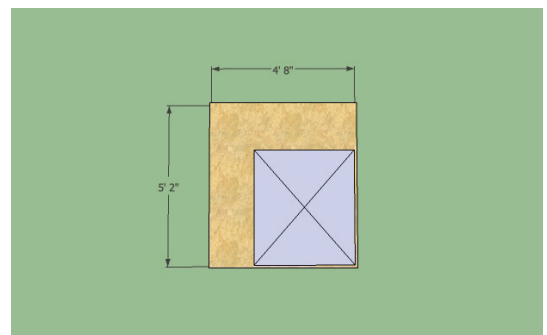

PLAN VIEW

EXHIBIT B.5

LANDFORM
From Site to Finish

DESIGN FRAMEWORK
The COR at Ramsey
COMMUNITY KIOSK 'B'
Sunwood Dr. & Center St.



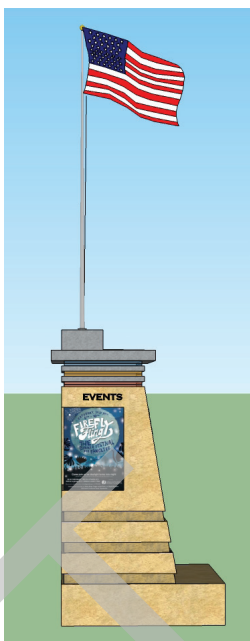
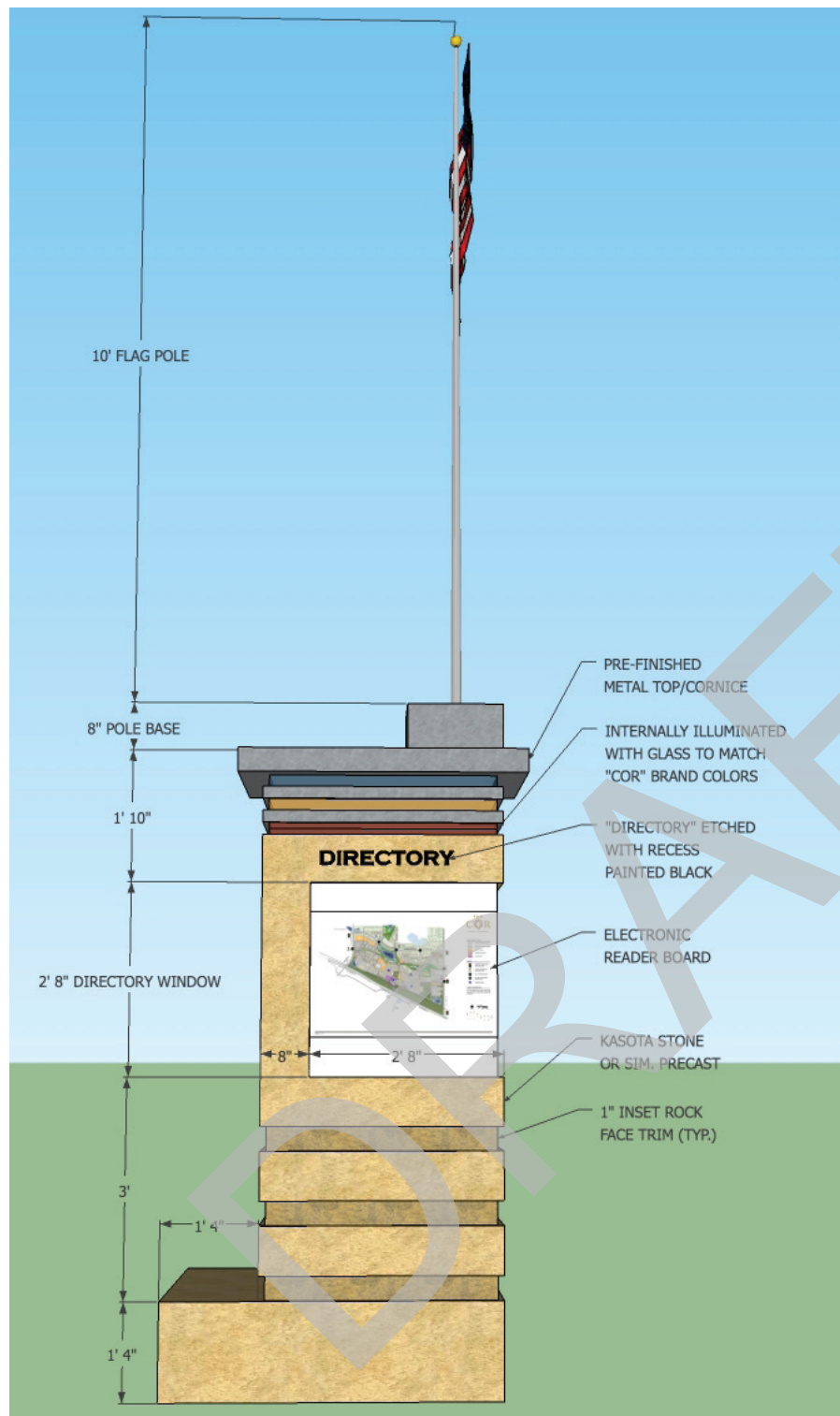

EVENTS PANEL VIEW

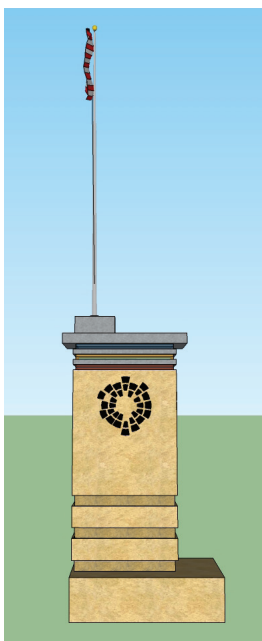

REAR VIEW

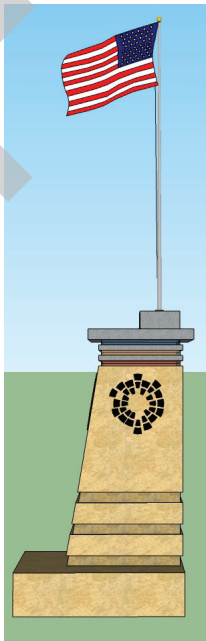

SIDE VIEW



PERSPECTIVE

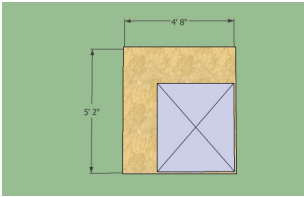

PLAN VIEW

DIRECTORY PANEL VIEW

EXHIBIT B.6

LANDFORM
From Site to Finish

DESIGN FRAMEWORK
The COR at Ramsey
COMMUNITY KIOSK 'C'
Sunwood Dr. at Municipal Plaza



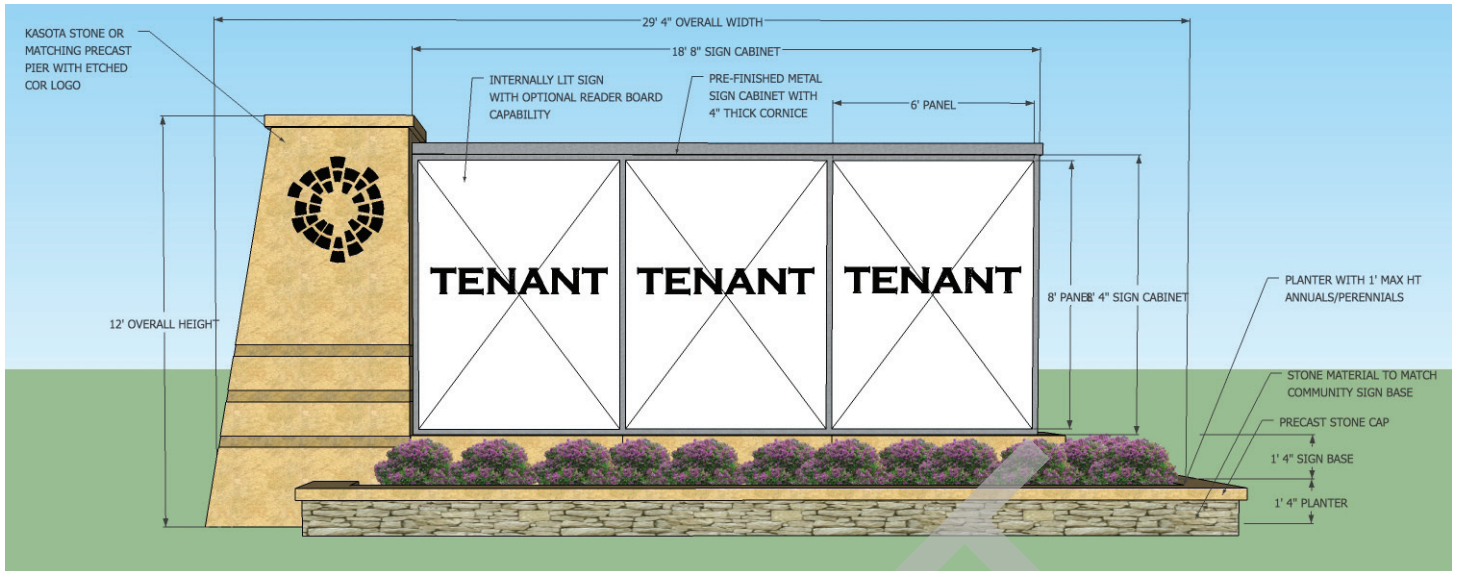

ELEVATION AT SUNWOOD

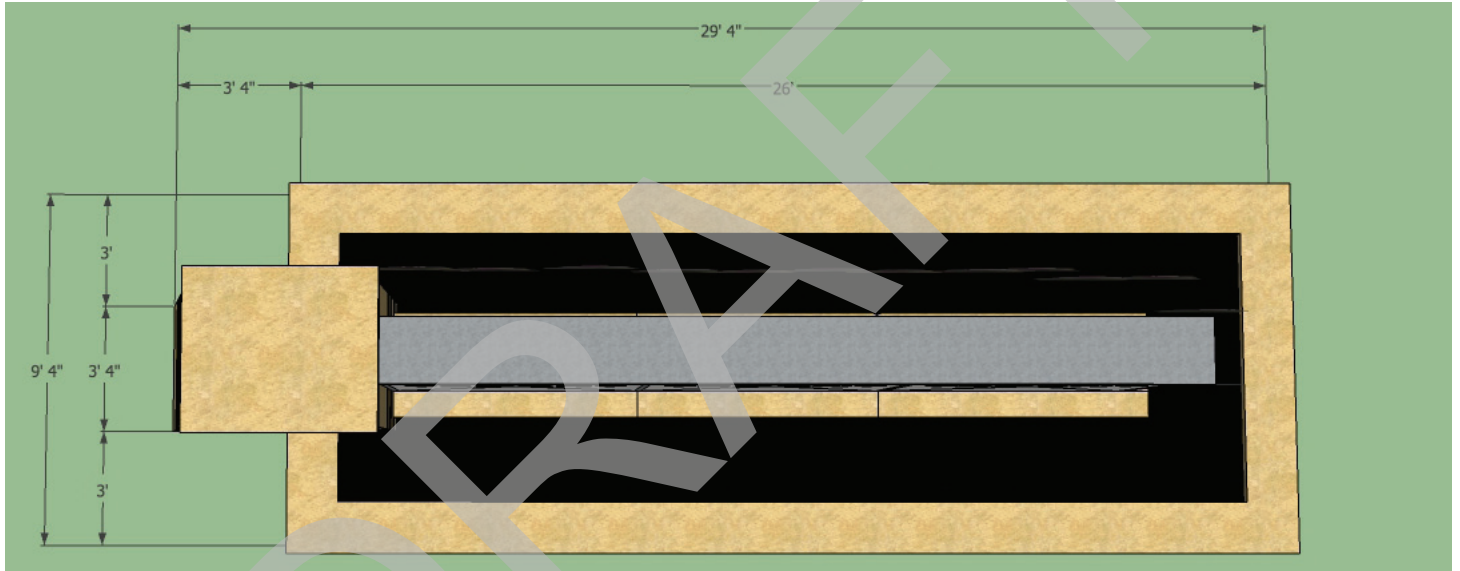

PLAN VIEW

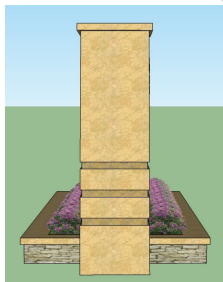

PROFILE VIEW

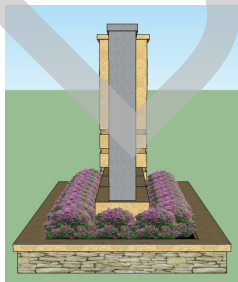

PROFILE VIEW

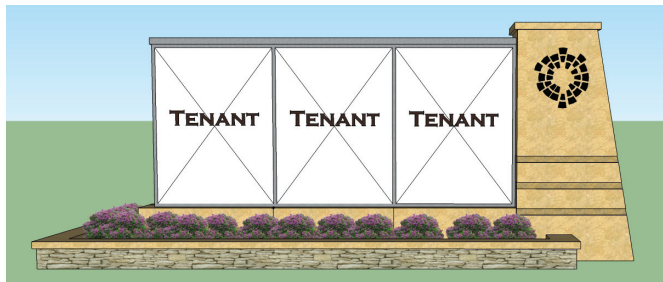

ELEVATION

EXHIBIT B.7



DESIGN FRAMEWORK
 The COR at Ramsey
 PROJECT GATEWAY SIGN 'A'
 Sunwood Dr. & Armstrong Blvd.



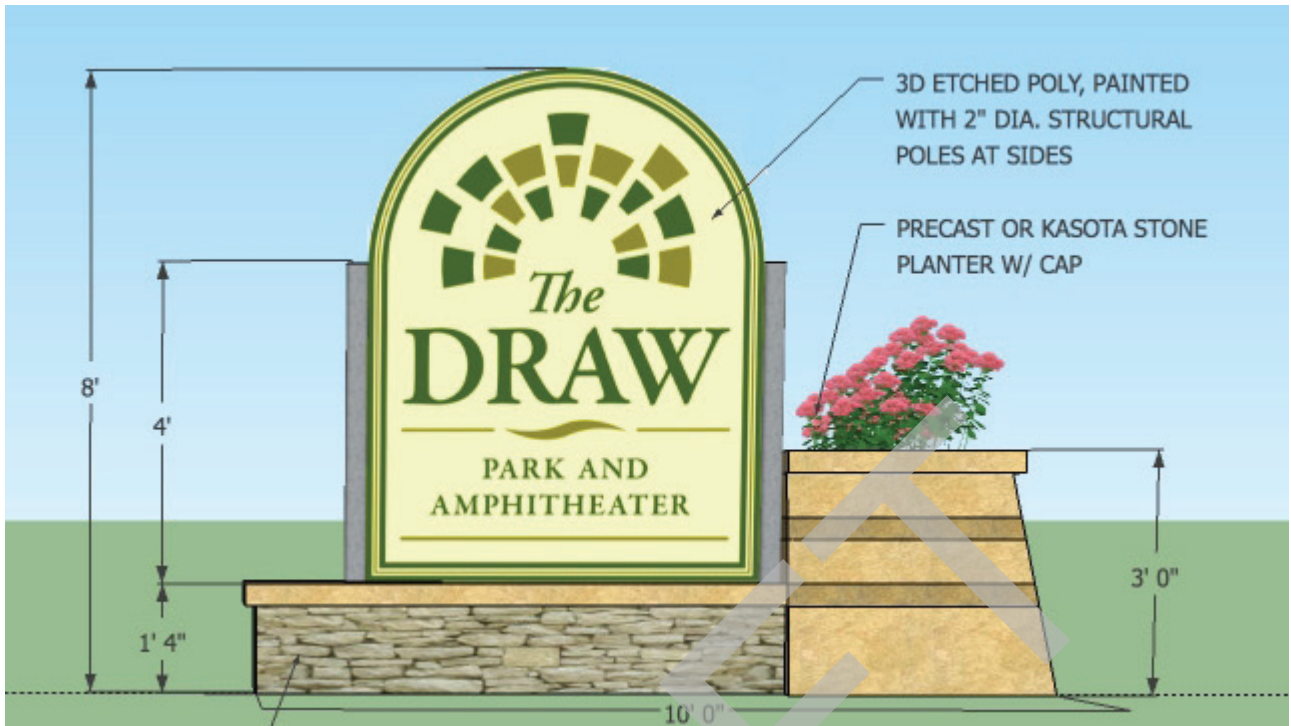

EXHIBIT B.8

●
●

L A N D F O R M

 From Site to Finish

DESIGN FRAMEWORK
 The COR at Ramsey
PUBLIC PARK SIGNS



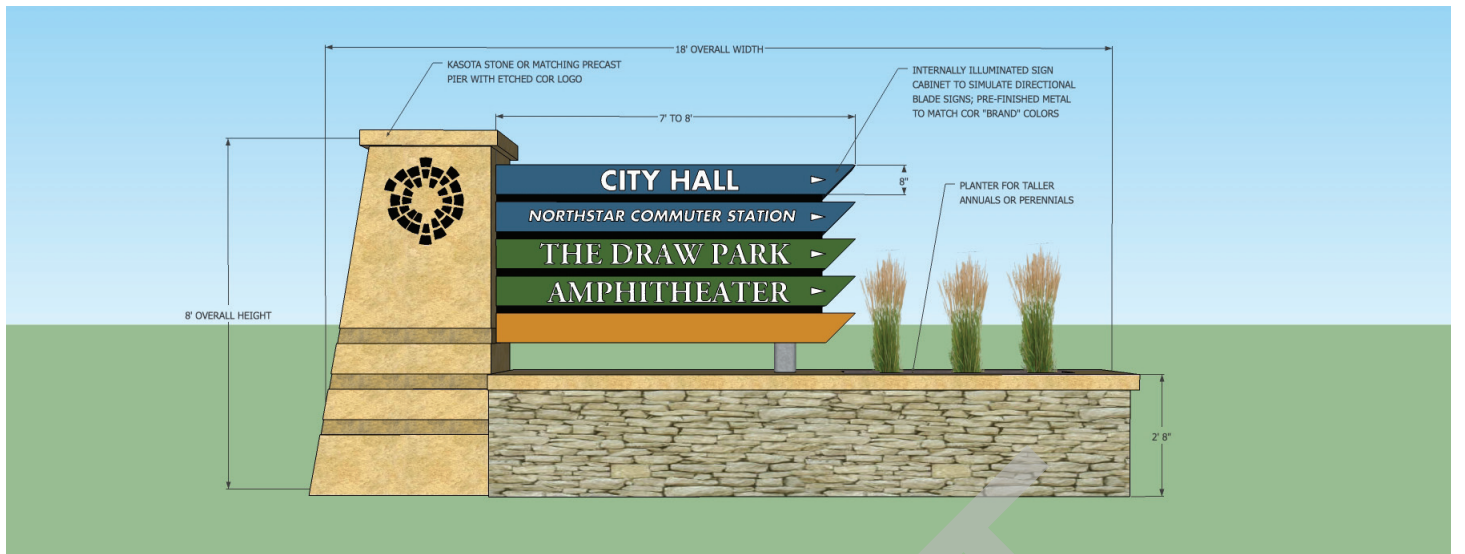

ELEVATION AT EASTBOUND BUNKER LAKE

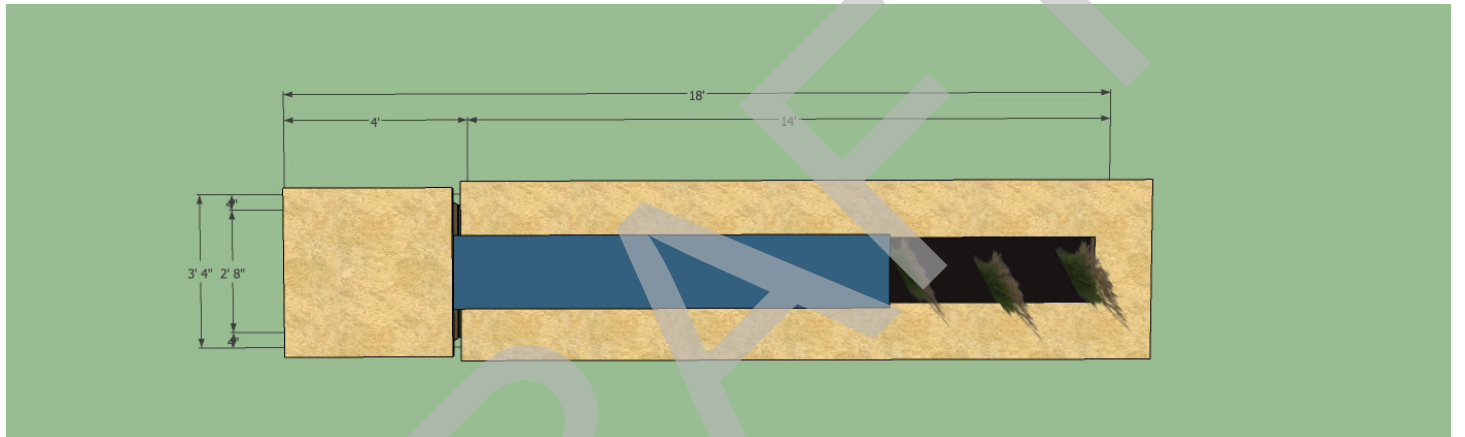

PLAN VIEW



PROFILE VIEW

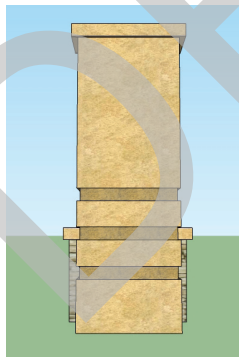

PROFILE VIEW



ELEVATION AT WESTBOUND BUNKER LAKE

EXHIBIT B.9

LANDFORM
From Site to Finish

DESIGN FRAMEWORK
The COR at Ramsey
PROJECT GATEWAY SIGN 'C'
Bunker Lake Blvd. & Center St.





ELEVATION AT SOUTH BOUND RAMSEY

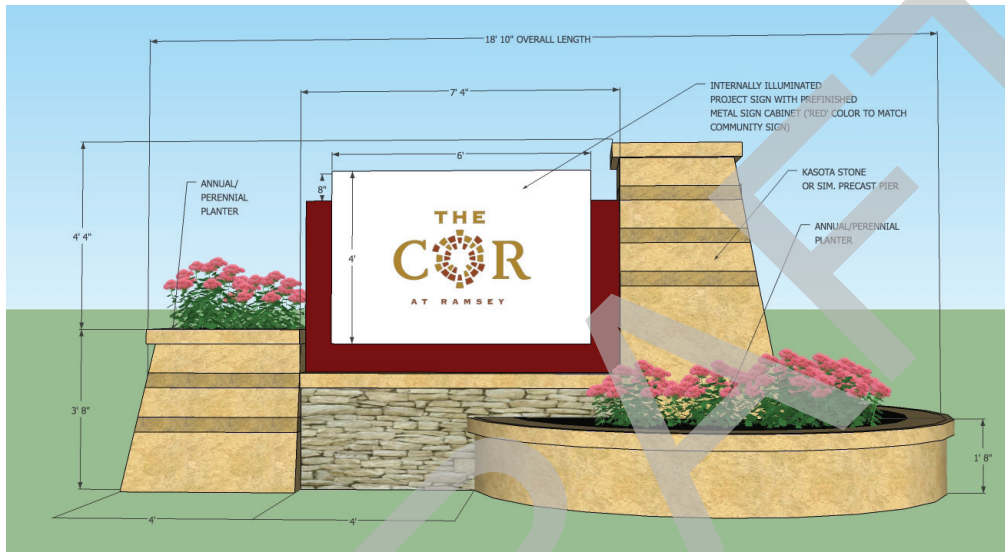

ELEVATION AT WESTBOUND BUNKER LAKE



PERSPECTIVE

EXHIBIT B.10

● ●
L A N D F O R M
 From Site to Finish

DESIGN FRAMEWORK
The COR at Ramsey
 PROJECT GATEWAY SIGN 'D'
 Bunker Lake Blvd. & Ramsey Blvd.



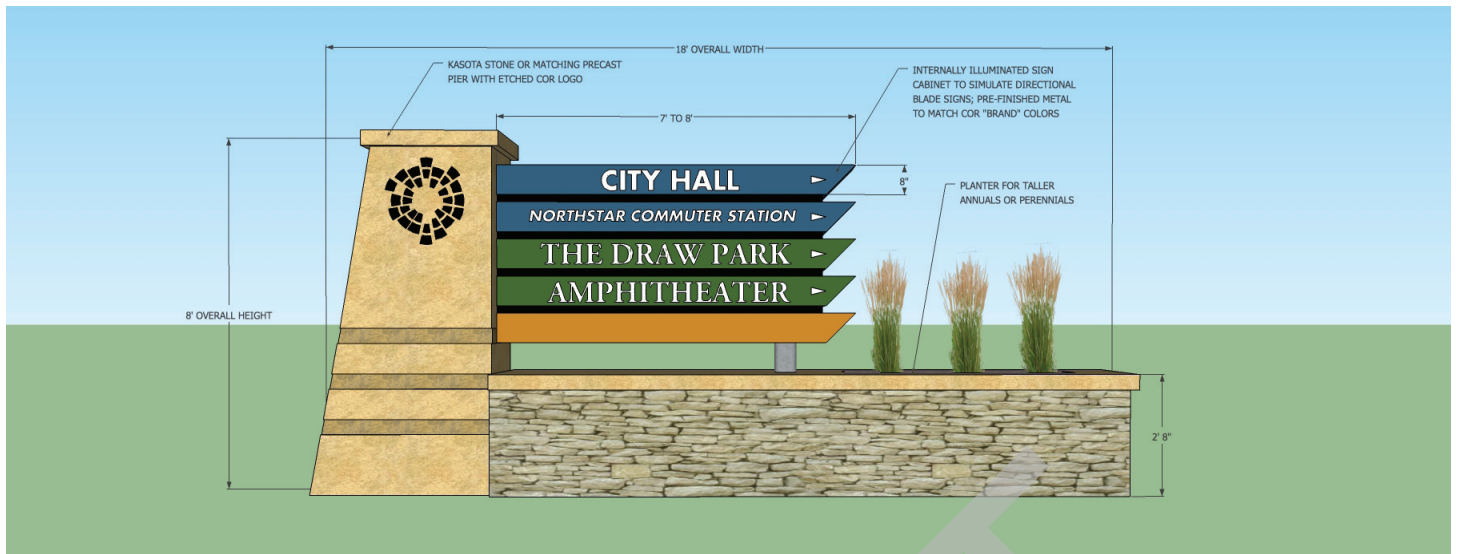

ELEVATION AT SOUTHBOUND RAMSEY

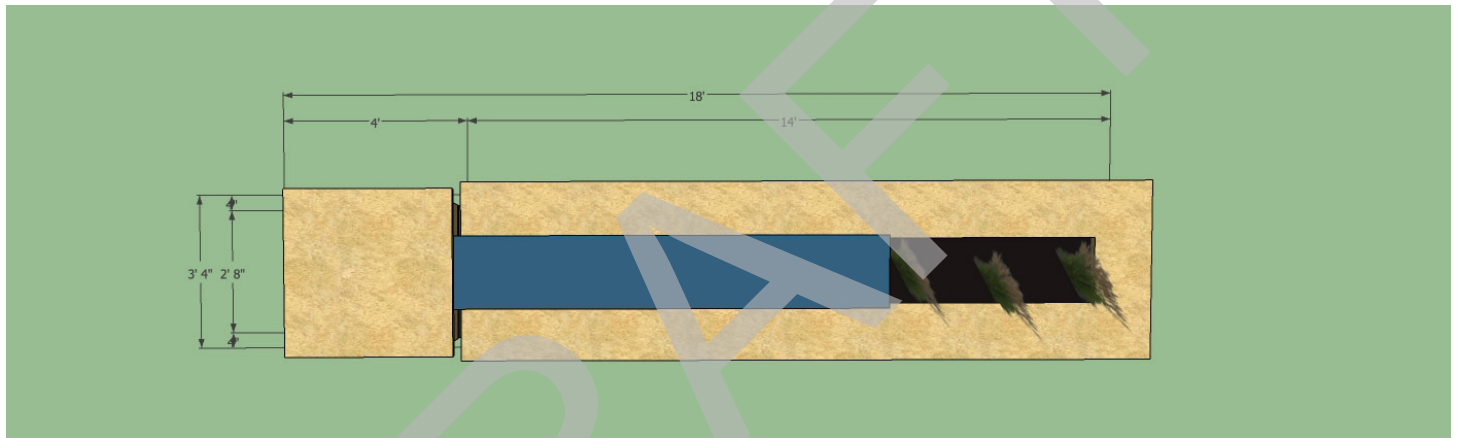

PLAN VIEW



PROFILE VIEW

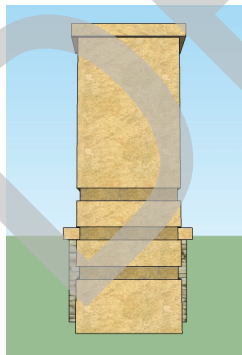

PROFILE VIEW



ELEVATION AT NORTHBOUND RAMSEY

EXHIBIT B.11



DESIGN FRAMEWORK
 The COR at Ramsey
 PROJECT GATEWAY SIGN 'E'
 Sunwood Dr. & Ramsey Blvd.





EXHIBIT B.12

●
●

L A N D F O R M

 From Site to Finish
 ●
●
●

DESIGN FRAMEWORK
 The COR at Ramsey
PUBLIC PARKING SIGNAGE
Standard Signage



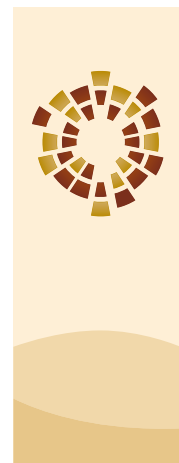
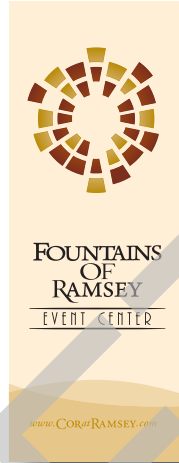
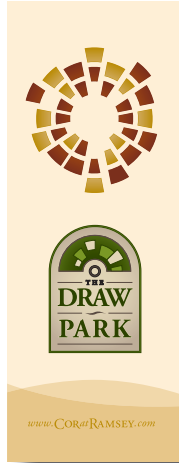

EXHIBIT B.13

LANDFORM
From Site to Finish

DESIGN FRAMEWORK
The COR at Ramsey
LIGHT POLE BANNER SIGNS
Standard Signage



NORTH

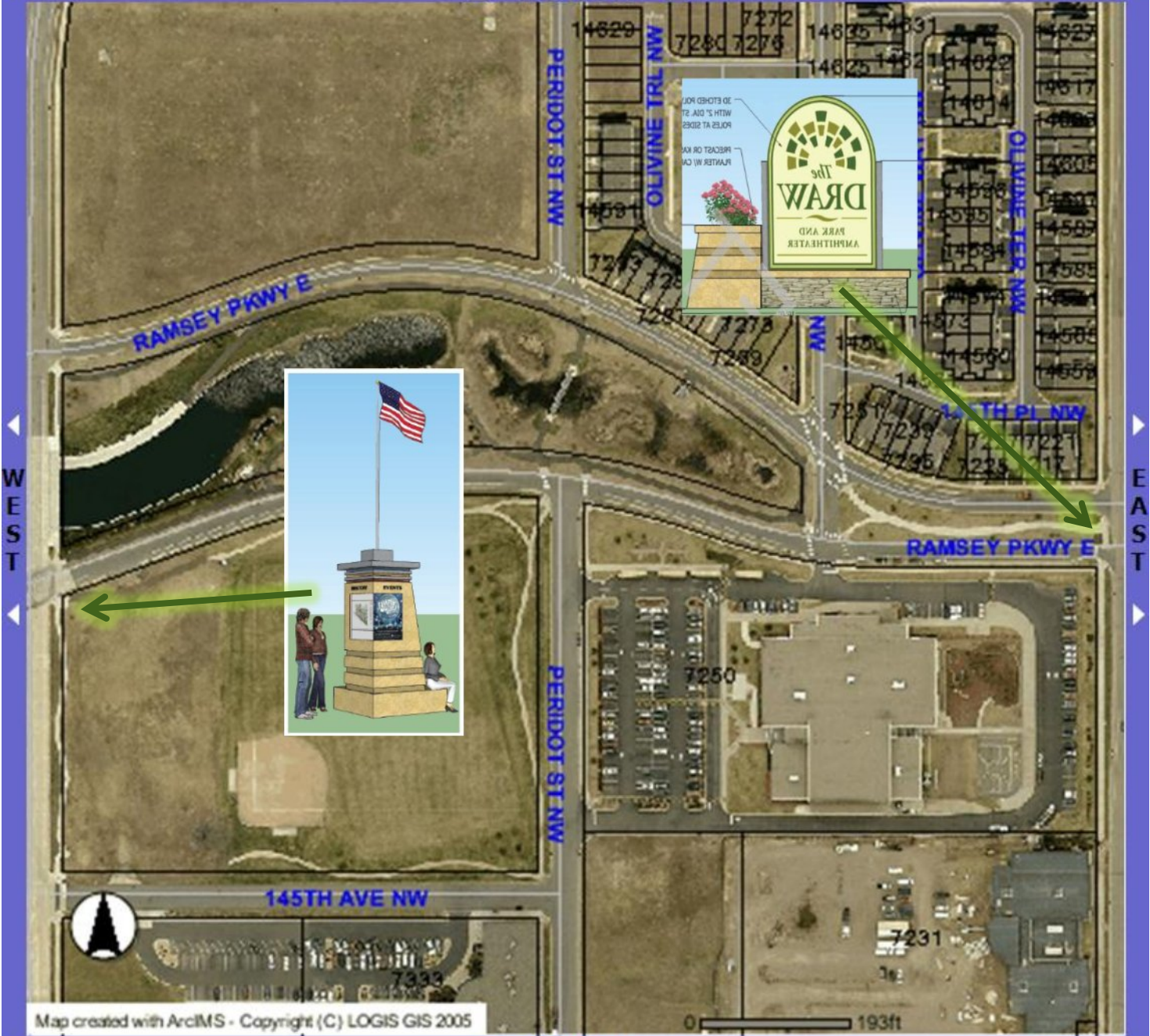

Map created with ArcIMS - Copyright (C) LOGIS GIS 2005

SOUTH

WEST

EAST

Proposal

Number: 20231
Date: 03/06/13



archetype

9635 Girard Ave. S
Minneapolis, Minnesota 55431

952 641 9600

archetypesign.com

Customer:	Project Location:
LANDFORM PROFESSIONAL SERVICES 105 SOUTH FITFTH AVENUE SUITE 513 MINNEAPOLIS MN 55401	The COR at Ramsey Sunwood Drive and East COR II Entry Ramsey MN 55303 REQUESTED BY: Mark Riverblood

1	QUOTE #45559-08 Furnish and install double sided exterior monument "The Draw" (exhibit B.8) sign. Overall sign face to be 48"x80" with 16" pole cover base. Sides have 4" square tube accents. Externally illuminated with flood lamps by others. Sign face to be 1/8" aluminum with digitally printed graphics. Sign base and stone base are not included.	\$7,600.00	\$7,600.00
1	QUOTE #45559-09 Furnish and install Community Kiosk "C". Kiosk to be fabricated aluminum cabinet with simple profile and fabricated aluminum base. No-illuminated is included. Graphics prints inside lockable hinged cabinet (prints not included). Flag pole and flag pole and flag pole base by others.	\$8,450.00	\$8,450.00
TOTAL PROPOSAL AMOUNT:			\$16,050.00

General Qualifications:

- Sales tax is additional
- Performance and payment bond if required is additional
- All electrical signage is wired for 120V primary with final electrical connection by others
- Permits if required are additional
- 1 Year warranty on fabricated components
- 5 Year warranty on finishes
- 90 Day warranty on electrical components

Accepted By: _____

Title: _____

Signature: _____

Date: _____

Archetype Representative: _____

Signature: _____

Date: _____



9635 Girard Ave. S
 Minneapolis, Minnesota 55431

952 641 9600

Deposit Invoice

Invoice Date: **03/06/13**
 Invoice Number: **DP20231**

Customer:	Project Location:
LANDFORM PROFESSIONAL SERVICES 105 SOUTH FITFTH AVENUE SUITE 513 MINNEAPOLIS MN 55401	The COR at Ramsey Sunwood Drive and East COR II Entry Ramsey MN 55303 REQUESTED BY: Mark Riverblood

Ordered By	PO Number	Salesperson	Order Date	Payment Terms	Due Date
Mark Riverblood		Joshua Ellis	03/05/13	50.0% Due Upon Receipt	03/06/13

Qty	Description	Unit Price	Total Price
1	QUOTE #45559-08 Furnish and install double sided exterior monument "The Draw" (exhibit B.8) sign. Overall sign face to be 48"x80" with 16" pole cover base. Sides have 4" square tube accents. Externally illuminated with flood lamps by others. Sign face to be 1/8" alumninum with digitally printed graphics. Sign base and stone base are not included.	\$7,600.00	\$7,600.00
1	QUOTE #45559-09 Furinsh and install Community Kiosk "C". Kiosk to be fabricated aluminum cabinet with simple profile and fabricated aluminum base. No-illuminated is included. Graphics prints inside lockable hinged cabinet (prints not included). Flag pole and flag pole and flag pole base by others.	\$8,450.00	\$8,450.00
TOTAL PROPOSAL AMOUNT			----- \$16,050.00
*** FINAL INVOICE AMOUNT MAY VARY UPON COMPLETION ***			

Please Pay This Deposit Amount: \$8,025.00

Proposal

Number: **19569**
Date: **01/30/13**



archetype

9635 Girard Ave. S
Minneapolis, Minnesota 55431

952 641 9600

archetypesign.com

Customer:		Project Location:	
LANDFORM PROFESSIONAL SERVICES 105 SOUTH FITFTH AVENUE SUITE 513 MINNEAPOLIS MN 55401		The COR at Ramsey Sunwood Drive and East COR II Entry Ramsey MN 55303	
		REQUESTED BY: Matt Rentsch	

1	QUOTE #45559-06 Furnish and install double sided exterior monument "The Draw" (exhibit B.8) sign. Overall sign face to be 48"x80" Externally illuminated with flood lamps by others. Sign face to be 1/8" alumninum with digitally printed graphics. Sign base and planter to be fabricated aluminum with 2 color paint finish.	\$15,250.00	\$15,250.00
1	QUOTE #45559-07 Furnish and install Community Kiosk "C". Kiosk to be fabricated aluminum, with non-illuminated caps. Graphics to be custom fabricated light boxes with static translucent illuminated prints. Flag pole and flag pole and flag pole base by others.	\$14,200.00	\$14,200.00
TOTAL PROPOSAL AMOUNT:			\$29,450.00

General Qualifications:

- Sales tax is additional
- Performance and payment bond if required is additional
- All electrical signage is wired for 120V primary with final electrical connection by others
- Permits if required are additional
- 1 Year warranty on fabricated components
- 5 Year warranty on finishes
- 90 Day warranty on electrical components

Accepted By: _____

Title: _____

Signature: _____

Date: _____

Archetype Representative: _____

Signature: _____

Date: _____

Proposal

Number: **19568**
Date: **01/30/13**



archetype

9635 Girard Ave. S
Minneapolis, Minnesota 55431

952 641 9600

archetypesign.com

Customer:	Project Location:
LANDFORM PROFESSIONAL SERVICES 105 SOUTH FITFTH AVENUE SUITE 513 MINNEAPOLIS MN 55401	The COR at Ramsey Sunwood Drive and East COR II Entry Ramsey MN 55303 REQUESTED BY: Matt Rentsch

1	QUOTE #45559-04 Furnish and install double sided exterior monument "The Draw" (exhibit B.8) sign. Externally illuminated with flood lamps by others. Flat lexan with vinyl graphics.	\$28,300.00	\$28,300.00
1	QUOTE #45559-05 Furnish and install Community Kiosk "C". Kiosk to be constructed of Kasota Stone, internally illuminated caps. Graphics to be custom fabricated light boxes with static translucent illuminated prints. Flag pole and flag pole and flag pole base by others.	\$33,290.00	\$33,290.00
TOTAL PROPOSAL AMOUNT:			\$61,590.00

General Qualifications:

- Sales tax is additional
- Performance and payment bond if required is additional
- All electrical signage is wired for 120V primary with final electrical connection by others
- Permits if required are additional
- 1 Year warranty on fabricated components
- 5 Year warranty on finishes
- 90 Day warranty on electrical components

Accepted By: _____

Title: _____

Signature: _____

Date: _____

Archetype Representative: _____

Signature: _____

Date: _____

The Draw 2013

Presented by:



Summer Event Series

These events are FREE to the public!

Food and Drinks will be available for purchase before and during events!

DATE: **TIME:** **ACT:**

June 20 **6:30-8:00pm** **Roadhouse Blue Band**
Roadhouse Blue is a variety/classic country/rock band. Free Killebrew Root Beer floats and samples of Killebrew Root Beer will be distributed to everyone in attendance. *Sponsor: RJM and Killebrew Root Beer*

June 27 **6:30-8:00pm** **Dirt Road Prophets**
The Dirt Road Prophets specialize in country from the golden era, they will mix in top 40 country songs, and a little rock. *Sponsor: Bolton & Menk and Trott Brook Financial*

July 11 **6:30-8:00pm** **Stimulus Package**
No genre is off limits for SP, putting an invigorating spin on all the hits from classic rock to rocking country and everything in between. *Sponsor: Open and Village Bank*

July 18 **6:30-8:00pm** **Bill and Tom Show**
The Bill & Tom Show is a 2 man Guitar/Piano Duo playing popular good time songs from the 60's and 70's. *Sponsor: Field Law, P.A.*

July 25 **6:30-8:00pm** **1st Things 1st**
1st Things 1st is a tribute to great writers and performers of 40's and 50's. The musical revue is a fun, high energy show that has delighted all ages. *Sponsor: Open*

Aug 01 **6:30-8:00pm** **BOB FM Night**
BOB FM will host this special evening, with a band and many free giveaways. This is also COBORN's customer appreciation dinner night. *Sponsor: Coborn's & Ramsey Rotary*

Aug 08 **6:30-8:00pm** **Splatter Sisters**
This is a great opportunity for the whole family and kids of all ages. The Splatter Sisters show is a style of sassy-folk and jazz based vocals. *Sponsor: Connexus Energy*

Aug 15 **6:30-8:00pm** **Church of Cash**
The Church of Cash is the Midwest's best Johnny Cash Tribute show performing a multitude of hits spanning Johnny's entire career! *Sponsor: Open*

Aug 22 **6:30-8:00pm** **Elvis, Todd Anderson**
Elvis is a delightfully entertaining show for all ages! Todd's voice and moves are an exciting depiction of an actual Elvis concert. *Sponsor: Ramsey HRA/ The COR at Ramsey*

Aug 29 **6:30-8:00pm** **The Audities and Time Well Spent**
These are local teenagers playing from the Braven Music School. They play rock music like pretty women, Radar Love, Snow Blind and Iron Man. *Sponsor: Open*

Sep 05 **6:30-8:00pm** **Dan Perry and Ice Cream**
Dan Perry and Ice Cream perform 60s/70s classic rock, blues, R&B, pop, jazz, country and originals with their 13 member band. *Sponsor: Open*

Sep 12 **5:30-7:30pm** **Park Patron Picnic**
Community picnic with a live broadcast from BOB FM. Shop at the farmers market and you will receive free food from the grill. *Sponsor: Ramsey Park and Recreation Commission*



Thursday nights from June 20- Sept 12 there will be an event at 'The Draw' Amphitheater

FARMERS MARKET adjacent to the amphitheater in The Draw every Thursday beginning on July 11 from 3-7!

LOCATION 'The Draw' 7401 E Ramsey Parkway, Ramsey, MN 55303 (within the COR)

Park and Recreation Commission

6. 1.

Meeting Date: 03/14/2013

By: Mark Riverblood, Engineering/Public Works

Information

Title:

Commission/Staff Input

- Final 2012-13 Rink Patronage Count In: 5,953 persons counted at the warming houses - 3,085 at Central Park, 2,868 at Ramsey Elementary School (Use up *slightly* over preceeding winter)
- Update on the status of various 2013 Parks Capital Improvements
- April agenda items

Background:

.

Notification:

Observations/Alternatives:

Funding Source:

.

Staff Recommendation:

Action:

Form Review

Inbox
Grant Riemer

Form Started By: Mark Riverblood

Reviewed By
Grant Riemer

Final Approval Date: 03/08/2013

Date
03/08/2013 03:23 PM
Started On: 03/07/2013 12:39 PM