

# CITY OF RAMSEY

## 2018 STREET OVERLAY IMPROVEMENTS

### CITY IMPROVEMENT PROJECT NO. 18-03

## GOVERNING SPECIFICATIONS

THE 2018 EDITION OF THE MINNESOTA DEPARTMENT OF TRANSPORTATION "STANDARD SPECIFICATIONS FOR CONSTRUCTION" SHALL GOVERN.

ALL FEDERAL, STATE AND LOCAL LAWS, REGULATIONS AND ORDINANCES SHALL BE COMPLIED WITH IN THE CONSTRUCTION OF THIS PROJECT.

ALL TRAFFIC CONTROL DEVICES AND SIGNING SHALL CONFORM TO THE MINNESOTA MANUAL ON UNIFORM TRAFFIC CONTROL DEVICES, INCLUDING THE FIELD MANUAL FOR TEMPORARY TRAFFIC CONTROL ZONE LAYOUTS.

### SHEET INDEX

THIS PLAN CONTAINS 22 SHEETS

SHEET No.	DESCRIPTION
1	TITLE SHEET
2	STATEMENT OF ESTIMATED QUANTITIES
3	CITY DETAILS
4	PEDESTRIAN RAMP LAYOUTS
5 - 10	MINDOT PED RAMP DETAILS
11 - 12	WOODLAND GREEN OVERLAY
13 - 14	THE NORTH FORTY 2ND OVERLAY
15 - 18	THE NORTH FORTY 3RD OVERLAY
19	NORTHFORK ITASCA SHORES OVERLAY
20	NORTHFORK OVERLAY
21	NORTHFORK 2ND & 3RD OVERLAY
22	NORTHFORK OAKS OVERLAY

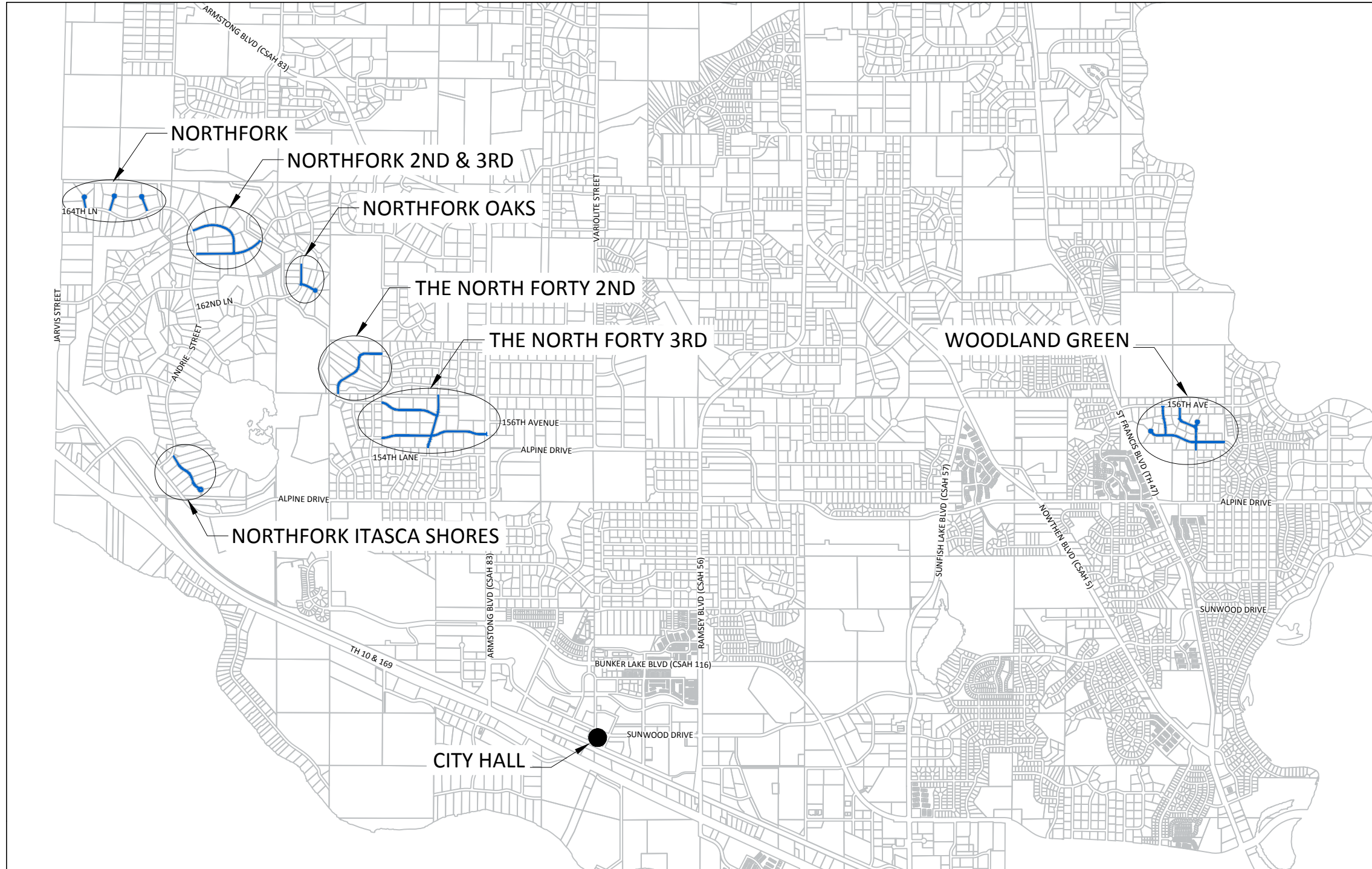

Apr. 03, 2018 - 11:58am  
c:\Engineering\AutoCad Dwg\Projects\18-03\Overlays\18-03\_2018\_Mill\_and\_Overlay\_Program\Plan\_Drawings\18-03\_Cover\_Sheet.dwg

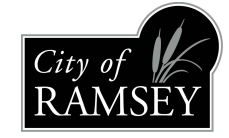

CITY OF RAMSEY  
7550 SUNWOOD DRIVE  
RAMSEY, MN 55303  
(763) 427-1410 FAX (763) 433-9898

THE SUBSURFACE UTILITY INFORMATION IN THIS PLAN IS UTILITY QUALITY LEVEL D. THIS QUALITY LEVEL WAS DETERMINED ACCORDING TO THE GUIDELINES OF CI/ASCE 38-02, ENTITLED "STANDARD GUIDELINES FOR THE COLLECTION AND DEPICTION OF EXISTING SUBSURFACE UTILITY DATA."

NOTE: EXISTING UTILITY INFORMATION SHOWN ON THIS PLAN HAS BEEN PROVIDED BY THE UTILITY OWNER. THE CONTRACTOR SHALL FIELD VERIFY EXACT LOCATIONS PRIOR TO COMMENCING CONSTRUCTION AS REQUIRED BY STATE LAW. NOTIFY GOPHER STATE ONE CALL 1-800-252-1166 OR 651-454-0002



I hereby certify that this plan, specification, or report was prepared by me or under my direct supervision and that I am a duly Licensed Professional Engineer under the laws of the State of Minnesota.

*Bruce R Westby*  
BRUCE R WESTBY, P.E.  
RAMSEY CITY ENGINEER

40116 DATE 4/3/18  
LIC. NO.

DATE	REVISION

**18-03 2018 OVERLAY IMPROVEMENTS  
STATEMENT OF ESTIMATED QUANTITIES**

PAGE No.	NOTE	MNDOT No.	DESCRIPTION	UNIT	ESTIMATED QUANTITY
		2021.501	MOBILIZATION	LS	1
4	1	2104.503	REMOVE CONCRETE PAVEMENT	SF	66
11 - 22	1	2104.505	REMOVE BITUMINOUS PAVEMENT	SY	113
19 - 22		2104.509	REMOVE CASTING	EA	10
11 - 22	1	2104.513	SAWING BITUMINOUS PAVEMENT	LF	1,325
19 - 22	2	2211.503	AGGREGATE BASE CLASS 5 MODIFIED (CV)	CY	8
20 - 22	1	2231.604	BITUMINOUS PATCH	SY	1,932
11 - 12	1	2232.501	EDGE MILL BITUMINOUS PAVEMENT 7' X (0" - 2")	SY	6,600
11 - 22	1	2232.501	MILL BITUMINOUS PAVEMENT	SY	170
11 - 22	3	2357.502	BITUMINOUS MATERIAL FOR TACK COAT	GAL	4,423
11 - 22	4	2360.501	TYPE SP 9.5 WEARING COURSE MIXTURE (SPWEA340C) (2.0")	TON	6,947
19 - 22		2506.516	CASTING ASSEMBLY	EA	10
19 - 22	6	2506.521	INSTALL CASTING	EA	10
11 - 12	6	2506.602	RESET CATCH BASIN / MANHOLE CASTING	EA	10
4		2521.501	6" CONCRETE WALK	SF	120
19 - 22		2531.501	CONCRETE CURB & GUTTER DESIGN SURMOUNTABLE	LF	100
4		2531.618	TRUNCATED DOMES	SF	32
	5	2563.601	TRAFFIC CONTROL	LS	1
19 - 22	2	2574.525	COMMON TOPSOIL BORROW (LV)	CY	20
19 - 22		2575.505	SODDING TYPE LAWN	SY	141

**PAY ITEM NOTES:**

- REMOVAL LIMITS SHALL BE MARKED IN THE FIELD BY CITY STAFF.
- EV TO CV CONVERSION FACTOR = 1.2.
- ESTIMATED QUANTITY BASED ON APPLICATION RATE OF 0.07 GAL/SY.
- ESTIMATED QUANTITY BASED ON APPLICATION RATE OF 110 LB/SY-IN.
- LUMP SUM QUANTITY SHALL INCLUDE ALL COST REQUIRED FOR MAINTAINING ALL FLAGGING OPERATIONS AS NECESSARY, MAINTAINING PEDESTRIAN ACCESS ROUTES, ANY SIGNAGE AND BARRICADES AS NECESSARY.
- PAY ITEM INCLUDES ALL REQUIRED ADJUSTMENTS TO CASTINGS AS WELL AS THE ADDITION AND/OR REPLACEMENT OF ADJUSTMENT RINGS, GROUTING OF THE INSIDE OF THE ADJUSTMENT RINGS AND DOGHOUSES TO A SMOOTH FINISH.

**GENERAL NOTES:**

- THE LOCATIONS OF EXISTING UNDERGROUND UTILITIES ARE SHOWN IN AN APPROXIMATE WAY ONLY. IT IS NOT GUARANTEED ANY OR ALL EXISTING UTILITIES ARE SHOWN. THE CONTRACTOR SHALL DETERMINE THE EXACT LOCATION OF ALL EXISTING UTILITIES BEFORE COMMENCING WORK. HE AGREES TO BE FULLY RESPONSIBLE FOR ANY AND ALL DAMAGES WHICH MIGHT BE OCCASIONED BY HIS FAILURE TO EXACTLY LOCATE AND PRESERVE ANY AND ALL UNDERGROUND UTILITIES.

DATE	REVISION

I hereby certify that this plan, specification, or report was prepared by me or under my direct supervision and that I am a duly Licensed Professional Engineer under the laws of the State of Minnesota

*Bruce Westby*  
Bruce Westby  
Date: 4/3/18 Lic. No. 40116

DESIGNED BY: JJF  
DRAWN BY: JJF  
CHECKED BY: BRW  
DATE: 4/3/18  
FILE No. 18-03

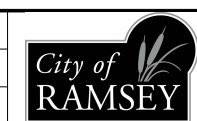

CITY OF RAMSEY  
7550 SUNWOOD DRIVE  
RAMSEY, MN 55303  
(763) 427-1410 FAX (763) 433-9898

STATEMENT OF ESTIMATED QUANTITIES

2018 STREET OVERLAY IMPROVEMENTS  
CITY PROJECT NO. 18-03  
CITY OF RAMSEY, MINNESOTA

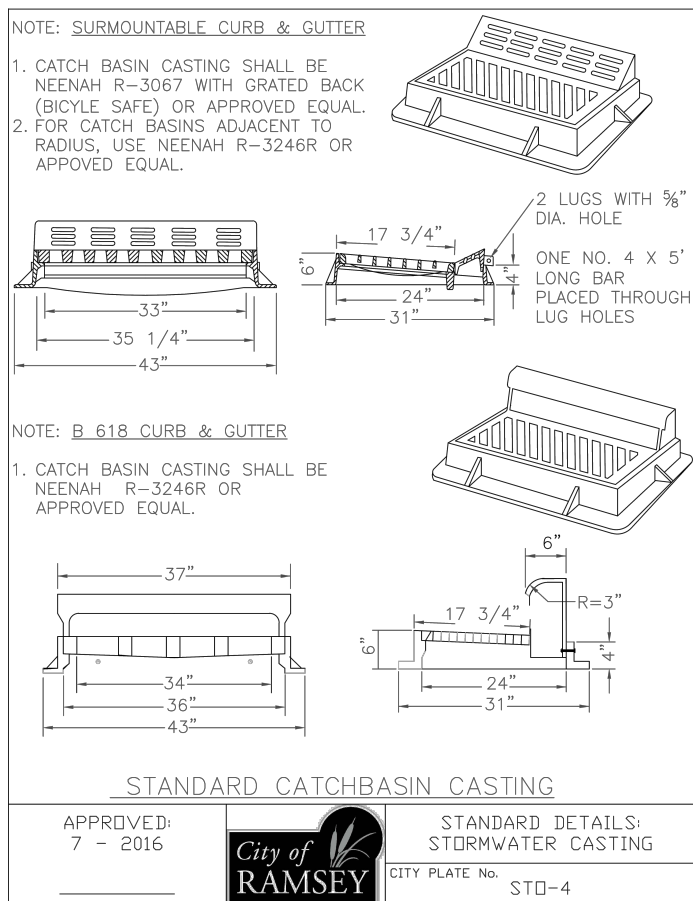
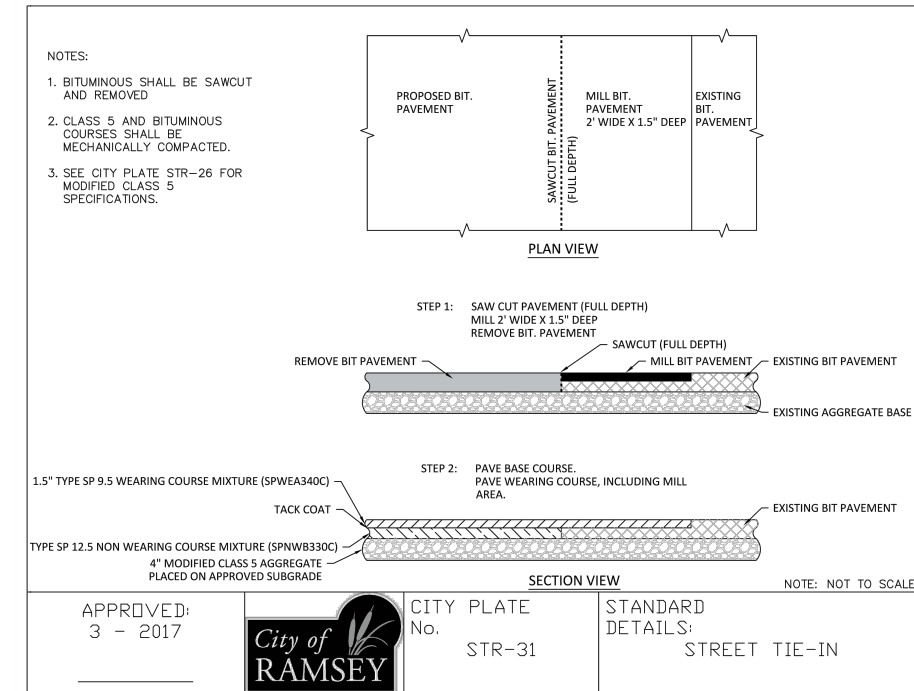
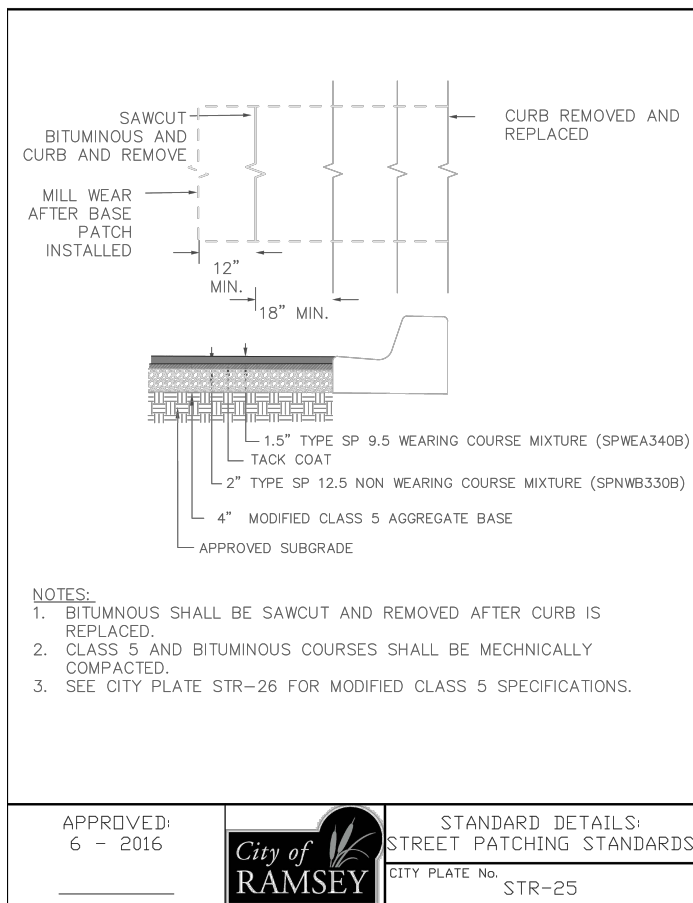
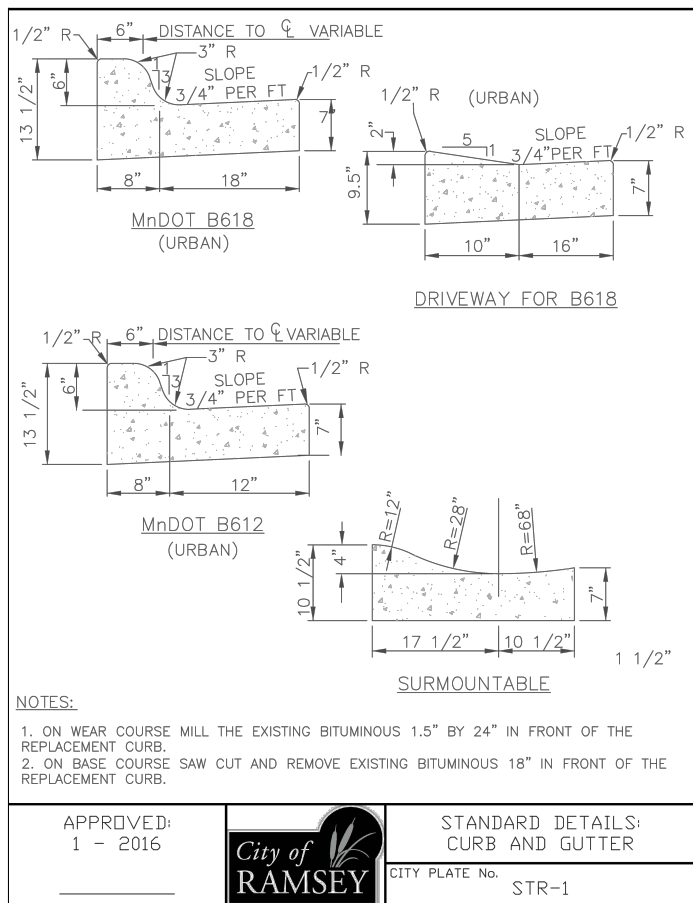

**TABLE A**

**MODIFIED CLASS 5 SPECIFICATIONS**

	% PASSING
1"	100
3/4"	90 - 100
3/8"	50 - 80
No. 4	35 - 70
No. 10	20 - 60
No. 40	10 - 35
No. 200	5 - 10

**NOTES:**

- THE AGGREGATE BASE CONSTRUCTION WILL BE ACCEPTED FOR PAYMENT IN ACCORDANCE WITH THE PROVISIONS IN TABLE A.
- IF THE AGGREGATE BASE FAILS TO MEET THE REQUIREMENTS OF TABLE A THE MATERIAL CAN BE CORRECTED IN PLACE OR REMOVED AND REPLACED WITH MATERIAL THAT MEET THE REQUIREMENTS OF TABLE A.
- IN THE EVENT THAT RECYCLED MATERIAL IS USE IT MUST MEET MNDOT REQUIREMENTS FOR RECYCLED BASE.

APPROVED: 2 - 2003

**City of RAMSEY**

STANDARD DETAILS: MODIFIED CLASS 5 SPECIFICATIONS

CITY PLATE No. STR-26

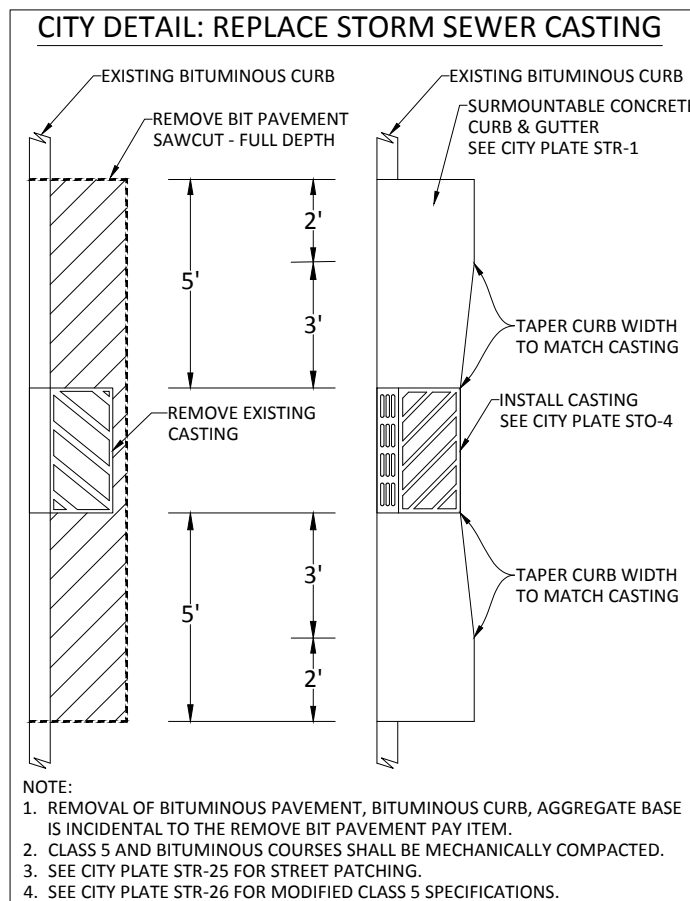

**MNDOT 2016 SPEC**

MNDOT 2016 SPEC TABLE 3877-1 COMMON TOPSOIL BORROW		
REQUIREMENT	RANGE	TEST METHOD
MATERIAL PASSING THE 3/4 IN [19MM]	100%	ASTM D 422
MATERIAL PASSING NO. 4 [4.75MM]	>85%	-
CLAY	5% - 35%	ASTM D 422
SILT	5% - 70%	ASTM D 422
SAND	10% - 75%	ASTM D 422
ORGANIC MATTER	3% - 15%	ASTM D 2974
pH	6.1-7.8	ASTM G 51

**NOTE:**

- INSTALLATION OF 4" OF TOPSOIL MEETING MNDOT SPECIFICATION 3877A COMMON TOPSOIL BORROW, MAY BE REQUIRED ACROSS ALL DISTURBED AREAS.
- A SOIL CERTIFICATION FROM A GEOTECHNICAL FIRM MUST BE PROVIDED VERIFYING THE TOPSOIL MEETS SPECIFICATION ALONG WITH LOAD TICKETS TO VERIFY THE SOURCE OF MATERIAL AND QUANTITY.
- TOPSOIL MUST COME FROM A CITY APPROVED SOURCE.

APPROVED: 1 - 2016

**City of RAMSEY**

CITY PLATE No. ERO-6

STANDARD DETAILS: TOPSOIL REQUIREMENTS

DATE	REVISION

I hereby certify that this plan, specification, or report was prepared by me or under my direct supervision and that I am a duly Licensed Professional Engineer under the laws of the State of Minnesota

*Bruce Westby*

Bruce Westby

Date: 4/3/18 Lic. No. 40116

DESIGNED BY: JJJ

DRAWN BY: JJJ

CHECKED BY: BRW

DATE: 4/3/18

FILE No. 18-03

**CITY OF RAMSEY**

7550 SUNWOOD DRIVE

RAMSEY, MN 55303

(763) 427-1410 FAX (763) 433-9898

CITY DETAILS

**2018 STREET OVERLAY IMPROVEMENTS**

**CITY PROJECT NO. 18-03**

CITY OF RAMSEY, MINNESOTA

5211

EXISTING 8' WIDE BITUMINOUS TRAIL

5201

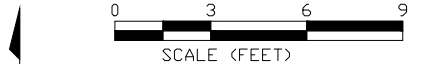

LEGEND

- 0" H.C. XXX.XX PROPOSED SPOT ELEV. ZERO HEIGHT CURB AT BACK OF CURB
- 6" H.C. XXX.XX PROPOSED SPOT ELEV. FULL HEIGHT CURB AT BACK OF CURB
- XXX.XX PROPOSED SPOT ELEV.
- LANDING AREA - MAX 2% SLOPE IN ALL DIRECTIONS.

ANDRIE COURT

6" THICK CONCRETE WALK

MATCH EXISTING 866.90

EXISTING 5' WIDE BITUMINOUS TRAIL

EXISTING BIT CURB

MATCH EXISTING 866.88

TRUNCATED DOMES - 16 SF

6.6'

F.H.C. 886.00

0" H.C. 866.00

0" H.C. 886.03

F.H.C. 886.15

R - 57

TRUNCATED DOMES - 16 SF

886.13

5.0'

5.0'

886.10

6.4%

6" THICK CONCRETE WALK

MATCH EXISTING 886.39

EXISTING BIT CURB

F.H.C. 867.05

0" H.C. 867.06

0" H.C. 867.02

F.H.C. 867.03

MATCH EXISTING 886.48

EXISTING 8' WIDE BITUMINOUS TRAIL

155TH LANE

9080

9050

PEDESTRIAN RAMP A DETAIL - WOODLAND GREEN

PEDESTRIAN RAMP B DETAIL - NORTHFORK ITASCA SHORES

DATE	REVISION

I hereby certify that this plan, specification, or report was prepared by me or under my direct supervision and that I am a duly Licensed Professional Engineer under the laws of the State of Minnesota

*Bruce Westby*  
Bruce Westby  
Date: 4/3/18 Lic. No. 40116

DESIGNED BY: JJF	DATE: 4/3/18
DRAWN BY: JJF	FILE No. 18-03
CHECKED BY: BRW	

CITY OF RAMSEY  
7550 SUNWOOD DRIVE  
RAMSEY, MN 55303  
(763) 427-1410 FAX (763) 433-9898

PEDESTRIAN RAMP LAYOUTS

2018 STREET OVERLAY IMPROVEMENTS  
CITY PROJECT NO. 18-03  
CITY OF RAMSEY, MINNESOTA

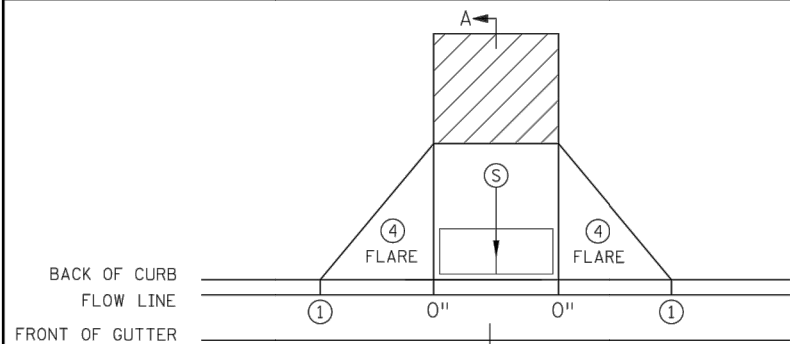

PERPENDICULAR

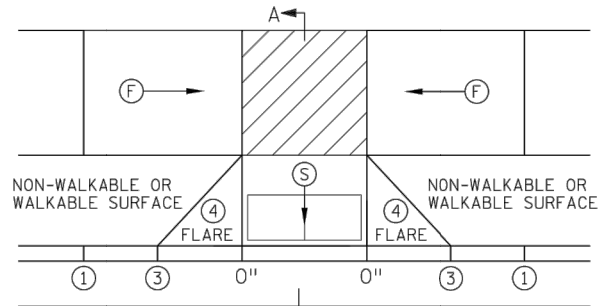

TIERED PERPENDICULAR

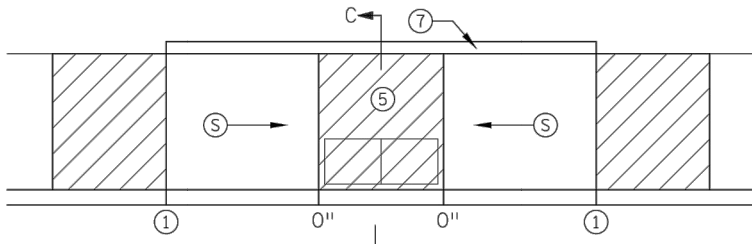

PARALLEL

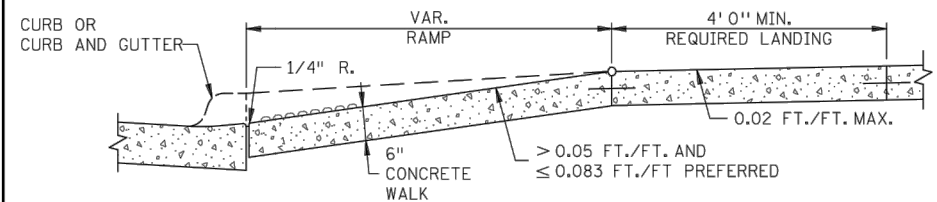

SECTION A-A  
PERPENDICULAR/TIERED/DIAGONAL

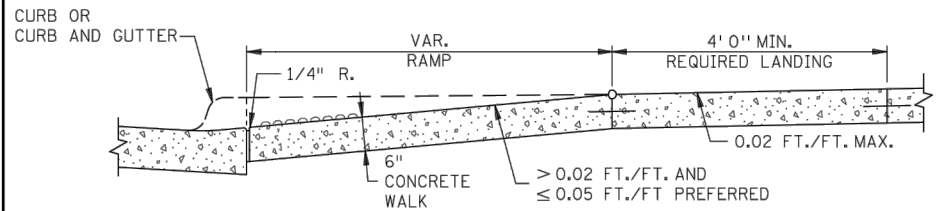

SECTION B-B  
FAN

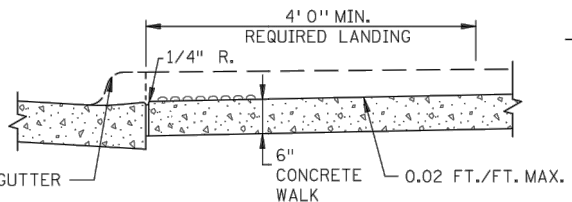

SECTION C-C  
PARALLEL/DEPRESSED CORNER

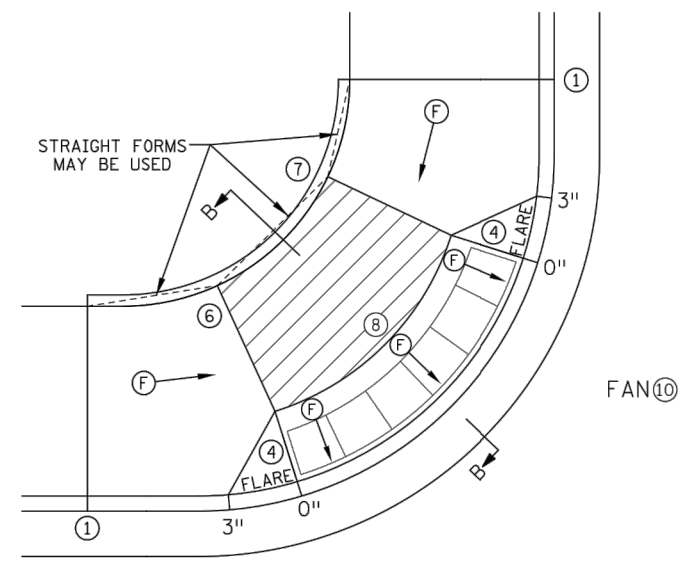

FAN 10

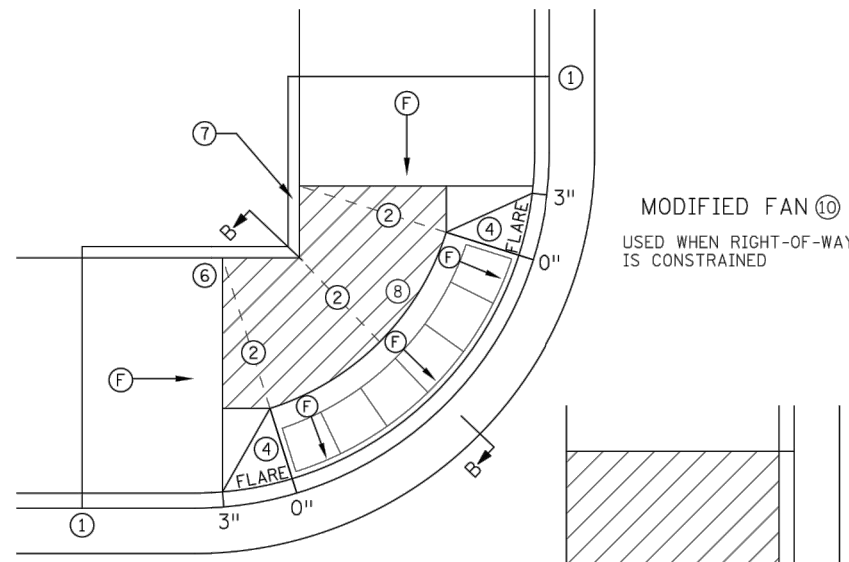

MODIFIED FAN 10  
USED WHEN RIGHT-OF-WAY IS CONSTRAINED

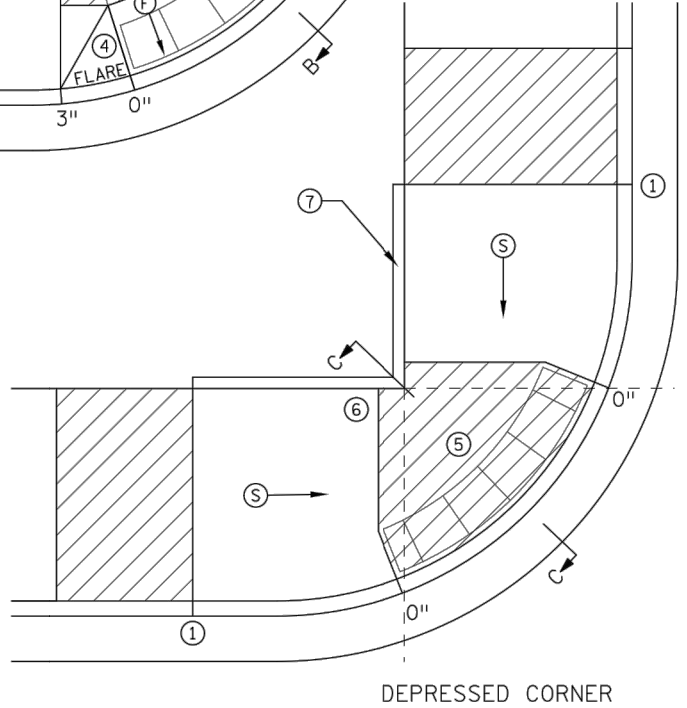

DEPRESSED CORNER

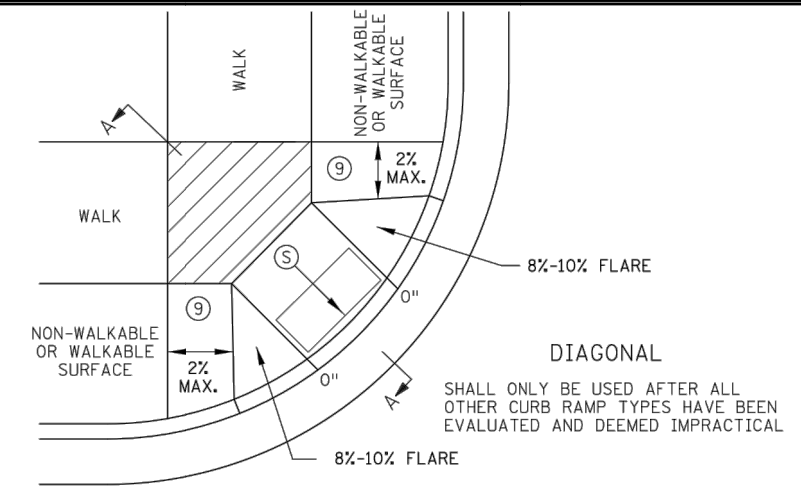

DIAGONAL

SHALL ONLY BE USED AFTER ALL OTHER CURB RAMP TYPES HAVE BEEN EVALUATED AND DEEMED IMPRACTICAL

NOTES:

- LANDINGS SHALL BE LOCATED ANYWHERE THE PEDESTRIAN ACCESS ROUTE (PAR) CHANGES DIRECTION, AT THE TOP OF RAMPS THAT HAVE RUNNING SLOPES GREATER THAN 5.0%, AND IF THE APPROACHING WALK IS INVERSE GRADE GREATER THAN 2%.
  - INITIAL CURB RAMP LANDINGS SHALL BE CONSTRUCTED WITHIN 15' FROM THE BACK OF CURB, WITH 6' FROM THE BACK OF CURB BEING THE PREFERRED DISTANCE, ONLY APPLICABLE WHEN THE INITIAL RAMP RUNNING SLOPE IS OVER 5.0%.
  - SECONDARY CURB RAMP LANDINGS ARE REQUIRED FOR EVERY 30" OF VERTICAL RISE WHEN THE LONGITUDINAL RUNNING SLOPE IS GREATER THAN 5.0%.
  - CONTRACTION JOINTS SHALL BE CONSTRUCTED ALONG ALL GRADE BREAKS WITHIN THE PAR. 1/4" DEEP VISUAL JOINTS SHALL BE USED AT THE TOPS OF CONCRETE FLARES ADJACENT TO WALKABLE SURFACES.
  - ALL GRADE BREAKS WITHIN THE PAR SHALL BE PERPENDICULAR TO THE PATH OF TRAVEL, THUS BOTH SIDES OF A SLOPED WALKING SURFACE MUST BE EQUAL LENGTH. (EXCEPT AS STATED IN 6 BELOW.)
  - TO ENSURE INITIAL RAMPS AND INITIAL LANDINGS ARE PROPERLY CONSTRUCTED, LANDINGS SHALL BE CAST SEPARATELY. FOLLOW SIDEWALK REINFORCEMENT DETAILS ON SHEET 6 AND THE ADA SPECIAL PROVISIONS - PROSECUTION OF WORK (ADA).
  - TOP OF CURB SHALL MATCH PROPOSED ADJACENT WALK GRADE.
  - WHEN THE BOULEVARD IS 4' WIDE OR LESS, THE TOP OF CURB TAPER SHALL MATCH THE RAMP SLOPES TO REDUCE NEGATIVE BOULEVARD SLOPES FROM THE TOP BACK OF CURB TO THE PAR.
  - ALL RAMP TYPES SHOULD HAVE A MINIMUM 3' LONG RAMP LENGTH.
  - 4' MINIMUM WIDTH OF DETECTABLE WARNING IS REQUIRED FOR ALL RAMPS. DETECTABLE WARNINGS SHALL CONTINUOUSLY EXTEND FOR A MIN. OF 24" IN THE PATH OF TRAVEL. DETECTABLE WARNING TO COVER ENTIRE WIDTH OF SHARED-USE PATHS AND THE ENTIRE PAR WIDTH OF THE WALK. DETECTABLE WARNING SHOULD BE 6" LESS THAN THE PAR/TRAIL WIDTH. ARC LENGTH OF RADIAL DETECTABLE WARNINGS SHOULD NOT BE GREATER THAN 20 FEET.
  - RECTANGULAR DETECTABLE WARNINGS SHALL BE SETBACK 3" FROM THE BACK OF CURB. RADIAL DETECTABLE WARNINGS SHALL BE SETBACK 3" MINIMUM TO 6" MAXIMUM FROM THE BACK OF CURB.
- 1 MATCH FULL HEIGHT CURB.
  - 2 4' MINIMUM DEPTH LANDING REQUIRED ACROSS TOP OF RAMP.
  - 3 3" HIGH CURB WHEN USING A 3' LONG RAMP, 4" HIGH CURB WHEN USING A 4' LONG RAMP.
  - 4 SEE SHEET 4 OF 6, TYPICAL SIDE TREATMENT OPTIONS, FOR DETAILS ON FLARES AND RETURNED CURBS, WHEN INITIAL LANDING IS AT FULL CURB HEIGHT.
  - 5 DETECTABLE WARNINGS MAY BE PART OF THE 4' X 4' MIN. LANDING AREA IF IT IS NOT FEASIBLE TO CONSTRUCT THE LANDING OUTSIDE OF THE DETECTABLE WARNING AREA.
  - 6 THE GRADE BREAK SHALL BE PERPENDICULAR TO THE BACK OF WALK. THIS WILL ENSURE THAT THE GRADE BREAK IS PERPENDICULAR TO THE DIRECTION OF TRAVEL. (TYPICAL FOR ALL)
  - 7 WHEN ADJACENT TO GRASS, GRADING SHALL ALWAYS BE USED WHEN FEASIBLE. V CURB, IF USED, SHALL BE PLACED OUTSIDE THE SIDEWALK LIMITS WHEN RIGHT OF WAY ALLOWS. WHEN ADJACENT TO PARKING LOTS, CONCRETE OR BITUMINOUS TAPERS SHOULD BE USED OVER V CURB TO REDUCE TRIPPING HAZARDS AND FACILITATE SNOW & ICE REMOVAL.
  - 8 A 7' MIN TOP RADIUS GRADE BREAK REQUIRED TO BE CONSTRUCTIBLE.
  - 9 PAVE FULL WALK WIDTH.
  - 10 "S" SLOPES ON FANS SHALL ONLY BE USED WHEN ALL OTHER FEASIBLE OPTIONS HAVE BEEN EVALUATED AND DEEMED IMPRACTICAL.

LEGEND	
(S)	INDICATES PEDESTRIAN RAMP - SLOPE SHALL BE BETWEEN 5.0% MINIMUM AND 8.3% MAXIMUM IN THE DIRECTION SHOWN AND THE CROSS SLOPE SHALL NOT EXCEED 2.0%.
(F)	INDICATES PEDESTRIAN RAMP - SLOPE SHALL BE GREATER THAN 2.0% AND LESS THAN 5.0% IN THE DIRECTION SHOWN AND CROSS SLOPE SHALL NOT EXCEED 2.0%.
[Hatched Box]	LANDING AREA - 4' X 4' MIN. (5' X 5' MIN. PREFERRED) DIMENSIONS AND MAX 2.0% SLOPE IN ALL DIRECTIONS. LANDING SHALL BE FULL WIDTH OF INCOMING PARS.
X"	CURB HEIGHT

REVISION:  
APPROVED: JANUARY 23, 2017  
OPERATIONS ENGINEER

MINNESOTA DEPARTMENT OF TRANSPORTATION  
STATE DESIGN ENGINEER  
APPROVED: 1-23-2017

PEDESTRIAN CURB RAMP DETAILS  
STANDARD PLAN 5-297.250 1 OF 6

DATE	REVISION

I hereby certify that this plan, specification, or report was prepared by me or under my direct supervision and that I am a duly Licensed Professional Engineer under the laws of the State of Minnesota  
Bruce Westby  
Date: 4/3/18 Lic. No. 40116

DESIGNED BY: JJF  
DRAWN BY: JJF  
CHECKED BY: BRW  
DATE: 4/3/18  
FILE NO.: 18-03

CITY OF RAMSEY  
7550 SUNWOOD DRIVE  
RAMSEY, MN 55303  
(763) 427-1410 FAX (763) 433-9898

MNDOT PED RAMP DETAILS

2018 STREET OVERLAY IMPROVEMENTS  
CITY PROJECT NO. 18-03  
CITY OF RAMSEY, MINNESOTA

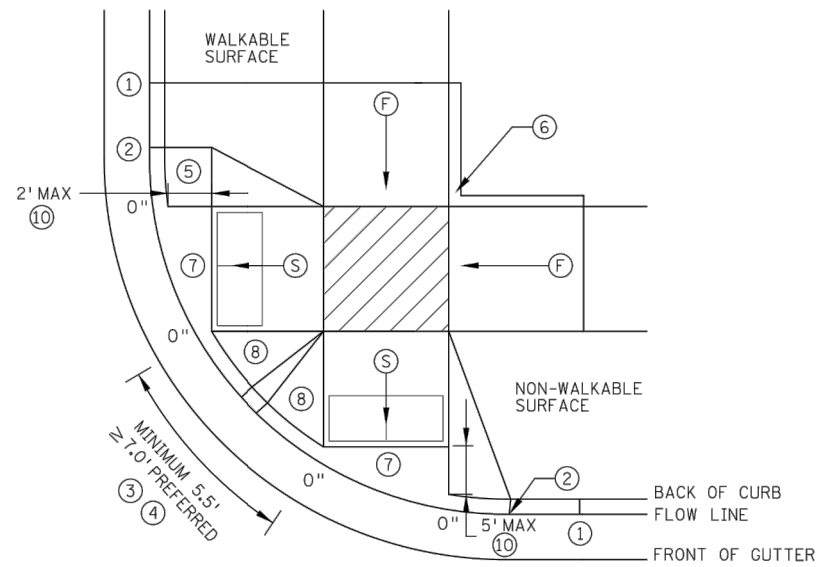

COMBINED DIRECTIONAL ⑨

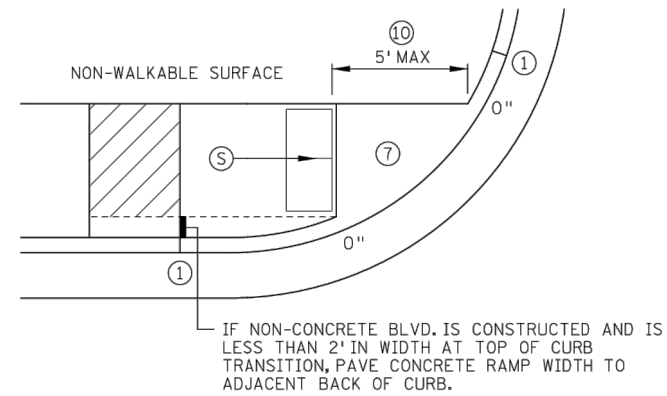

STANDARD ONE-WAY DIRECTIONAL ⑨

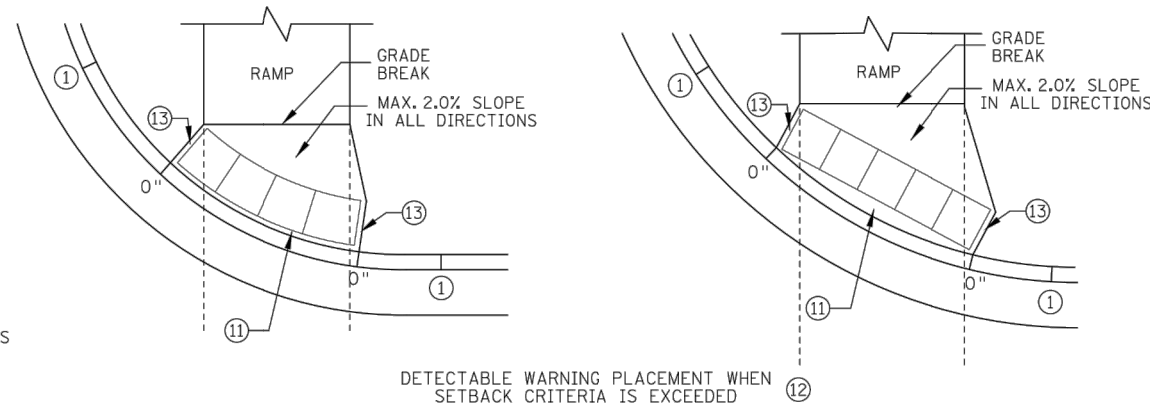

ONE-WAY DIRECTIONAL WITH DETECTABLE WARNING AT BACK OF CURB

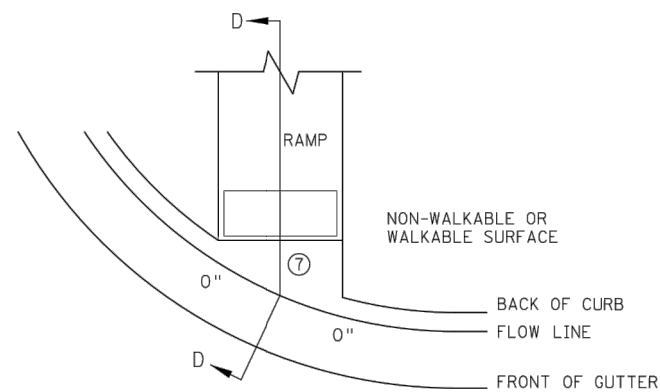

CURB FOR DIRECTIONAL RAMPS ⑭

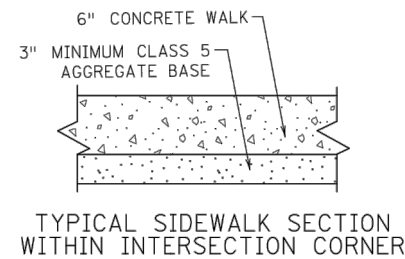
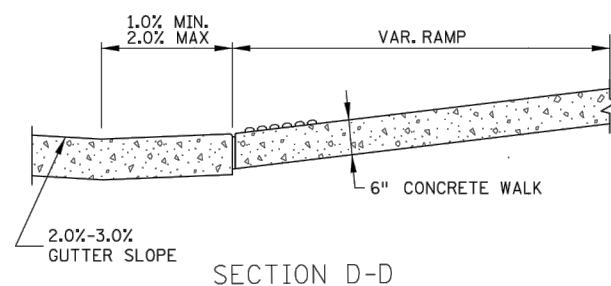

NOTES:

LANDINGS SHALL BE LOCATED ANYWHERE THE PEDESTRIAN ACCESS ROUTE (PAR) CHANGES DIRECTION, AT THE TOP OF RAMPS THAT HAVE RUNNING SLOPES GREATER THAN 5.0%, AND IF THE APPROACHING WALK IS INVERSE GRADE.

INITIAL CURB RAMP LANDINGS SHALL BE CONSTRUCTED WITHIN 15' FROM THE BACK OF CURB, WITH 6' FROM THE BACK OF CURB BEING THE PREFERRED DISTANCE, ONLY APPLICABLE WHEN THE INITIAL RAMP RUNNING SLOPE IS OVER 5.0%.

SECONDARY CURB RAMP LANDINGS ARE REQUIRED FOR EVERY 30" OF VERTICAL RISE WHEN THE LONGITUDINAL SLOPE IS GREATER THAN 5.0%.

CONTRACTION JOINTS SHALL BE CONSTRUCTED ALONG ALL GRADE BREAKS WITHIN THE PAR. 1/4" DEEP VISUAL JOINTS SHALL BE USED AT THE TOP GRADE BREAK OF CONCRETE FLARES ADJACENT TO WALKABLE SURFACES.

ALL GRADE BREAKS WITHIN THE PAR SHALL BE PERPENDICULAR TO THE PATH OF TRAVEL. THUS BOTH SIDES OF A SLOPED WALKING SURFACE MUST BE EQUAL LENGTH.

TO ENSURE INITIAL RAMPS AND INITIAL LANDINGS ARE PROPERLY CONSTRUCTED, LANDINGS SHALL BE CAST SEPARATELY. FOLLOW SIDEWALK REINFORCEMENT DETAILS ON SHEET 6 AND THE ADA SPECIAL PROVISION (PROSECUTION OF WORK).

TOP OF CURB SHALL MATCH PROPOSED ADJACENT WALK GRADE.

WHEN THE BOULEVARD IS 4' WIDE OR LESS, THE TOP OF CURB TAPER SHALL MATCH THE RAMP SLOPES TO REDUCE NEGATIVE BOULEVARD SLOPES FROM THE TOP BACK OF CURB TO THE PAR.

ALL RAMP TYPES SHOULD HAVE A MINIMUM 3' LONG RAMP LENGTH.

4' MINIMUM WIDTH OF DETECTABLE WARNING IS REQUIRED FOR ALL RAMPS. DETECTABLE WARNINGS SHALL CONTINUOUSLY EXTEND FOR A MIN. OF 24" IN THE PATH OF TRAVEL. DETECTABLE WARNING TO COVER ENTIRE WIDTH OF SHARED-USE PATH AND THE ENTIRE PAR WIDTH OF THE WALK. DETECTABLE WARNING SHOULD BE 6" LESS THAN THE PAR/PATH WIDTH. ARC LENGTH OF RADIAL DETECTABLE WARNINGS SHOULD NOT BE GREATER THAN 20 FEET.

RADIAL DETECTABLE WARNINGS SHALL BE SETBACK 3" MINIMUM TO 6" MAXIMUM FROM THE BACK OF CURB. SEE NOTES ⑩ & ⑪ FOR INFORMATION REGARDING RECTANGULAR DETECTABLE WARNING PLACEMENT.

- ① MATCH FULL CURB HEIGHT.
- ② 3" HIGH CURB WHEN USING A 3' LONG RAMP  
4" HIGH CURB WHEN USING A 4' LONG RAMP.
- ③ 3" MINIMUM CURB HEIGHT (5.5' MIN. DISTANCE REQUIRED BETWEEN DOMES)  
4" PREFERRED (7' MIN. DISTANCE REQUIRED BETWEEN DOMES).
- ④ THE "BUMP" IN BETWEEN THE RAMPS SHOULD NOT BE IN THE PATH OF TRAVEL FOR COMBINED DIRECTIONAL RAMPS. IF THIS OCCURS MODIFY THE RAMP LOCATION OR SWITCH RAMP TO A FAN/DEPRESSED CORNER.
- ⑤ WHEN USING CONCRETE PAVED FLARES ON THE OUTSIDE OF DIRECTIONAL RAMPS, AND ADJACENT TO A WALKABLE SURFACE, DIRECTIONAL RAMP FLARES SHOULD BE USED. SEE THE DETAIL ON THIS SHEET.
- ⑥ GRADING SHALL ALWAYS BE USED WHEN FEASIBLE. V CURB, IF USED, SHALL BE PLACED OUTSIDE THE SIDEWALK LIMITS WHEN RIGHT OF WAY ALLOWS. WHEN ADJACENT TO PARKING LOTS, CONCRETE OR BITUMINOUS TAPERS SHOULD BE USED OVER V CURB TO REDUCE TRIPPING HAZARDS AND FACILITATE SNOW & ICE REMOVAL.
- ⑦ MAX. 2.0% SLOPE IN ALL DIRECTIONS IN FRONT OF GRADE BREAK AND DRAIN TO FLOW LINE. SHALL BE CONSTRUCTED INTEGRAL WITH CURB AND GUTTER.
- ⑧ 8% TO 10% WALKABLE FLARE.
- ⑨ PLACE DOMES AT THE BACK OF CURB WHEN ALLOWABLE SETBACK CRITERIA IS EXCEEDED.
- ⑩ FRONT EDGE OF DETECTABLE WARNING SHALL BE SET BACK 2' MAXIMUM WHEN ADJACENT TO WALKABLE SURFACE, AND 5' MAXIMUM WHEN ADJACENT TO NON-WALKABLE SURFACE WITH ONE CORNER SET 3" FROM BACK OF CURB. A WALKABLE SURFACE IS DEFINED AS A PAVED SURFACE ADJACENT TO A CURB RAMP WITHOUT RAISED OBSTACLES THAT COULD MISTAKENLY BE TRAVERSED BY A USER WHO IS VISUALLY IMPAIRED.
- ⑪ RECTANGULAR DETECTABLE WARNINGS MAY BE SETBACK UP TO 9" FROM THE BACK OF CURB WITH CORNERS SET 3" FROM BACK OF CURB. IF 9" SETBACK IS EXCEEDED USE RADIAL DETECTABLE WARNINGS.
- ⑫ FOR DIRECTIONAL RAMPS WITH THE DETECTABLE WARNINGS PLACED AT THE BACK OF CURB, THE DETECTABLE WARNINGS SHALL COVER THE ENTIRE WIDTH OF THE WALK/PATH. THIS ENSURES A DETECTABLE EDGE AND HELPS ELIMINATE THE CURB TAPER OBSTRUCTING THE PATH OF PEDESTRIAN TRAVEL.
- ⑬ THE CONCRETE WALK SHALL BE FORMED AND CONSTRUCTED PERPENDICULAR TO THE BACK OF CURB. MAINTAIN 3" BETWEEN EDGE OF DOMES AND EDGE OF CONCRETE.
- ⑭ TO BE USED FOR ALL DIRECTIONAL RAMPS, EXCEPT WHERE DOMES ARE PLACED ALONG THE BACK OF CURB.

LEGEND	
THESE LONGITUDINAL SLOPE RANGES SHALL BE THE STARTING POINT. IF SITE CONDITIONS WARRANT, LONGITUDINAL SLOPES UP TO 8.3% OR FLATTER ARE ALLOWED.	
(S)	INDICATES PEDESTRIAN RAMP - SLOPE SHALL BE BETWEEN 5.0% MINIMUM AND 8.3% MAXIMUM IN THE DIRECTION SHOWN AND THE CROSS SLOPE SHALL NOT EXCEED 2.0%.
(F)	INDICATES PEDESTRIAN RAMP - SLOPE SHALL BE GREATER THAN 2.0% AND LESS THAN 5.0% IN THE DIRECTION SHOWN AND CROSS SLOPE SHALL NOT EXCEED 2.0%.
(Hatched Box)	LANDING AREA - 4' X 4' MIN. (5' X 5' MIN. PREFERRED) DIMENSIONS AND MAX 2.0% SLOPE IN ALL DIRECTIONS. LANDING SHALL BE FULL WIDTH OF INCOMING PAR.
X"	CURB HEIGHT

REVISION:
APPROVED: JANUARY 23, 2017
<i>Bruce Westby</i> OPERATIONS ENGINEER

MINNESOTA DEPARTMENT OF TRANSPORTATION

REVISOR: \_\_\_\_\_

APPROVED: *Tom Ska...*  
STATE DESIGN ENGINEER

1-23-2017

PEDESTRIAN CURB RAMP DETAILS

STANDARD PLAN 5-297.250

2 OF 6

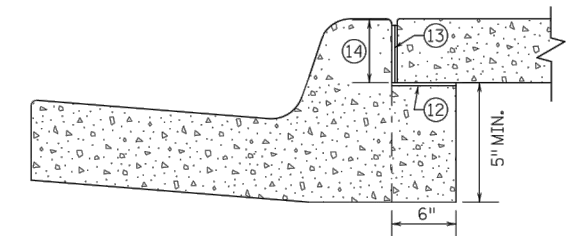
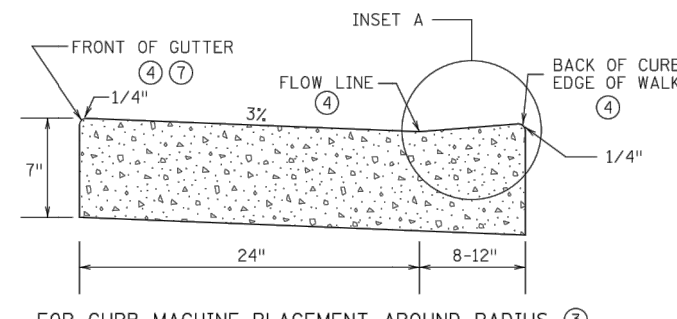
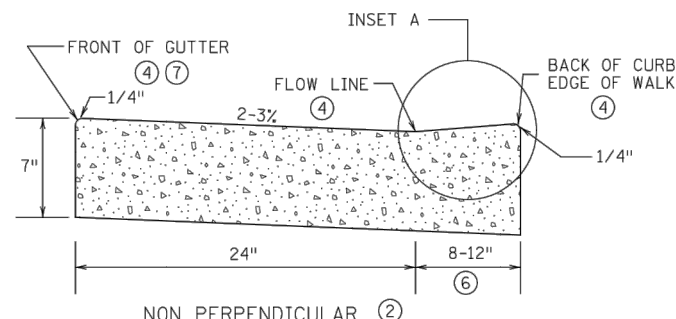
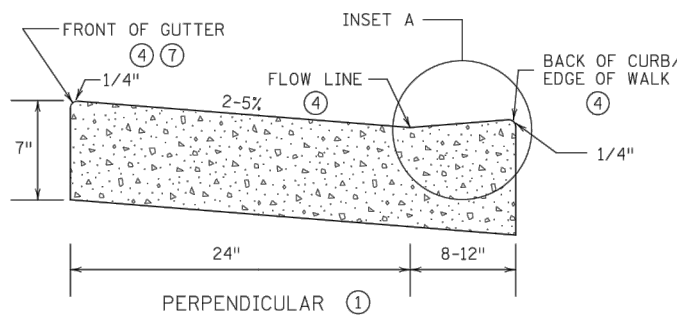

OPTIONAL SILL CURB WHEN SIDEWALK IS AT BACK OF CURB  
CONCRETE SILL TO BE USED ONLY WHEN SPECIFIED IN THE PLAN.

PEDESTRIAN ACCESS ROUTE CURB & GUTTER DETAIL

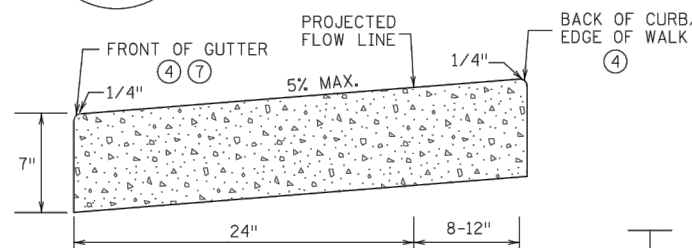
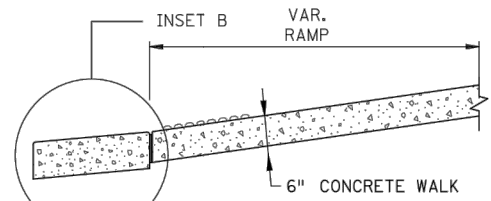

INSET B  
OUTFLOW GUTTER ⑧

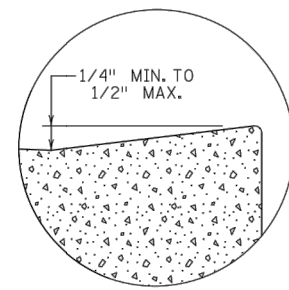

INSET A

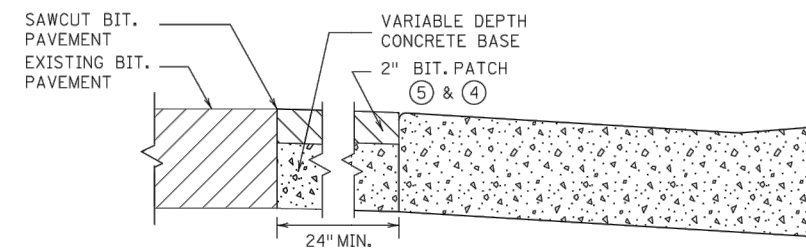
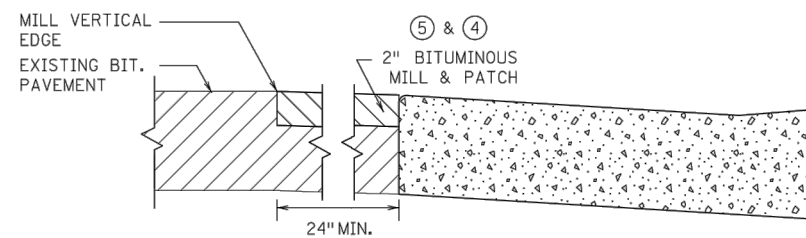

ONLY ALLOWED PER ENGINEER'S APPROVAL

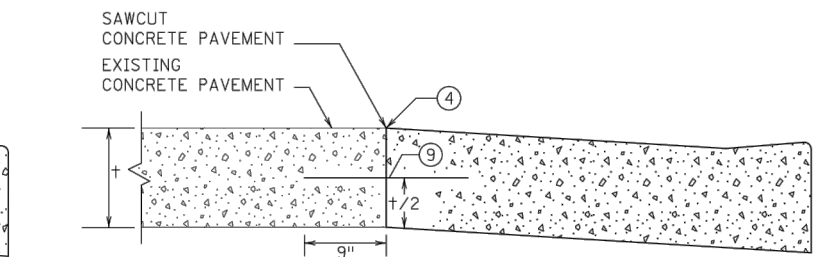
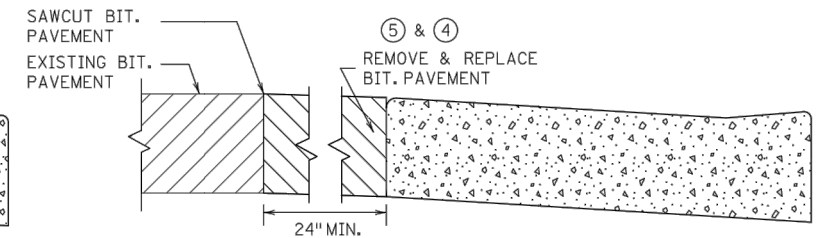

PAVEMENT TREATMENT OPTIONS IN FRONT OF CURB & GUTTER  
FOR USE ON CURB RAMP RETROFITS

NOTES:

POSITIVE FLOW LINE DRAINAGE SHALL BE MAINTAINED THROUGH THE PEDESTRIAN ACCESS ROUTE (PAR) AT A 2% MAXIMUM. NO PONDING SHALL BE PRESENT IN THE PAR.

ANY VERTICAL LIP THAT OCCURS AT THE FLOW LINE SHALL NOT BE GREATER THAN 1/4 INCH.

① FOR USE AT CURB CUTS WHERE THE PEDESTRIAN'S PATH OF TRAVEL IS ASSUMED PERPENDICULAR TO THE GUTTER FLOW LINE. RAMP TYPES INCLUDE: PERPENDICULAR, TIERED PERPENDICULAR, PARALLEL, AND DIAGONAL RAMPS.

② FOR USE AT CURB RAMPS WHERE THE PEDESTRIAN'S PATH OF TRAVEL IS ASSUMED NON PERPENDICULAR TO THE GUTTER FLOW LINE. RAMP TYPES INCLUDE: FANS & DEPRESSED CORNERS.

③ BEGIN GUTTER SLOPE TRANSITION 10' OUTSIDE OF ALL CURB RAMPS.

④ THERE SHALL BE NO VERTICAL DISCONTINUITIES GREATER THAN 1/4".

⑤ ELEVATION CHANGE TAKES PLACE FROM THE EXISTING TO NEW FRONT OF GUTTER. PATCH IS USED TO MATCH THE NEW GUTTER FACE INTO THE EXISTING ROADWAY.

⑥ VARIABLE WIDTH FOR DIRECTIONAL CURB APPLICATIONS. SEE SHEET 2 FOR DIRECTIONAL CURB SLOPE REQUIREMENTS.

⑦ TOP FRONT OF GUTTER SHALL BE CONSTRUCTED FLUSH WITH PROPOSED ADJACENT PAVEMENT ELEVATION. TOP 1.5" OF THE GUTTER FACE MUST BE A FORMED EDGE. PAR GUTTER SHALL NOT BE OVERLAID.

⑧ SHOULD BE USED AT VERTICALLY CONSTRAINED AREAS WHEN AT A DRAINAGE HIGH POINT OR SUPER ELEVATED ROADWAY SEGMENTS.

⑨ DRILL AND GROUT NO. 4 EPOXY-COATED 18" LONG TIE BARS AT 30" CENTER TO CENTER INTO EXISTING CONCRETE PAVEMENT 1' MINIMUM FROM ALL JOINTS.

⑩ HELPS PROVIDE TWO SEPARATE RAMPS, REDUCES THE DOME SETBACK LENGTH AND MINIMIZES DIRECTIONAL CURB. THIS RADIUS DESIGN CLOSELY FOLLOWS THE TURNING VEHICLE PATH WHILE OPTIMIZING CURB RAMP LENGTH.

⑪ CURB EXTENSIONS SHOULD BE USED IN VERTICALLY CONSTRAINED AREAS, USUALLY IN DOWNTOWN ROADWAY SEGMENTS WHERE ON-STREET PARKING IS AVAILABLE. CURB EXTENSIONS SHOULD BE CONSIDERED FOR APS INTERSECTIONS WHERE SPACE IS LIMITED. PUSH BUTTONS MUST MEET APS CRITERIA AS DESCRIBED IN THE PUSH BUTTON LOCATION DETAIL SHEET.

⑫ PLACE BOND BREAKER BETWEEN WALK AND TOP OF SILL.

⑬ 1/2" PREFORMED JOINT FILLER PER MNDOT SPEC. 3702.

⑭ DIMENSION TO BE SAME AS SIDEWALK THICKNESS, 4" MIN.

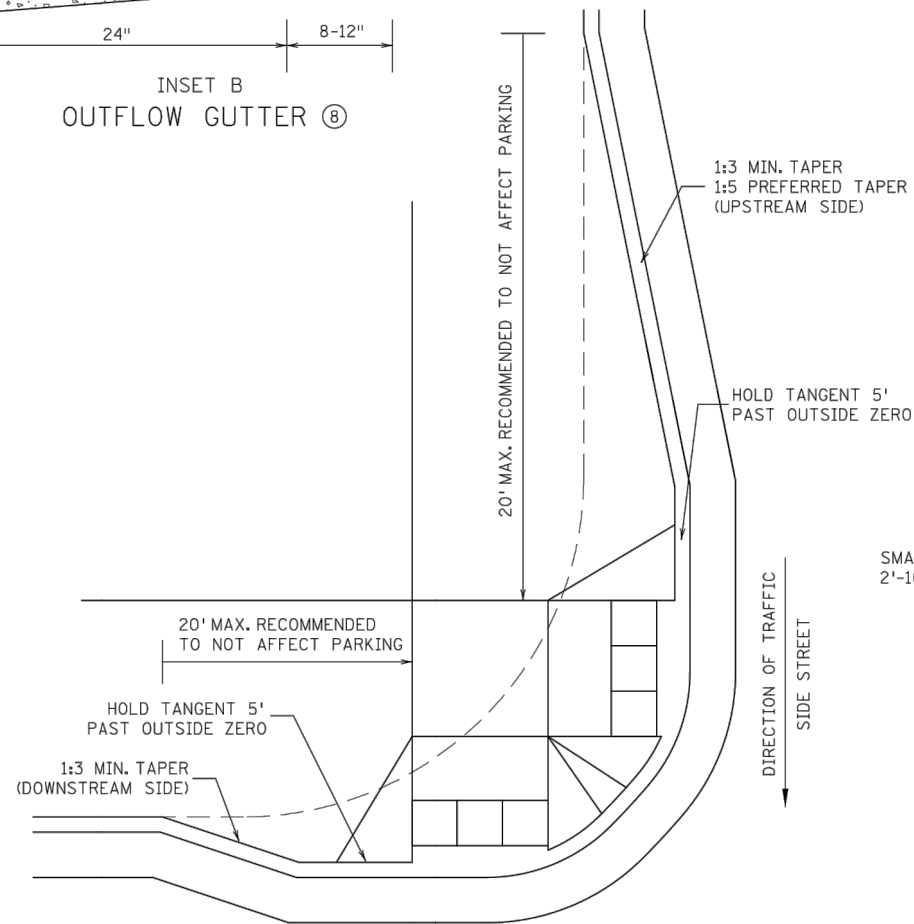

ADA CURB EXTENSION WITH COMPOUND RADIUS (BUMP OUT) ⑪

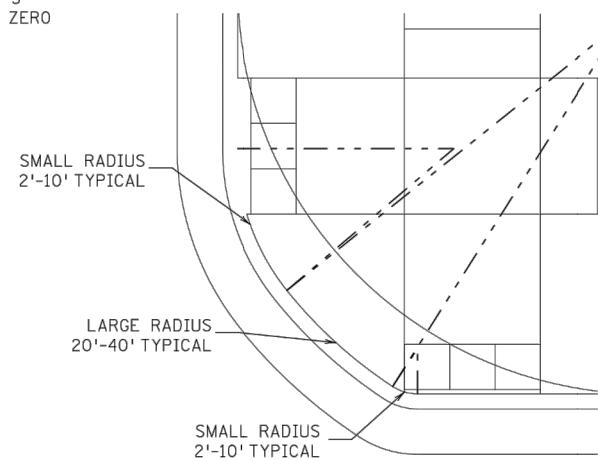

COMBINED DIRECTIONAL ⑩  
(COMPOUND RADIUS)

REVISION:
APPROVED: JANUARY 23, 2017
OPERATIONS ENGINEER

DIRECTION OF TRAFFIC  
MAIN STREET



REVISOR:  
APPROVED:  
1-23-2017  
STATE DESIGN ENGINEER

REVISOR:  
APPROVED:  
1-23-2017

PEDESTRIAN CURB RAMP DETAILS

STANDARD PLAN 5-297.250 3 OF 6

DATE	REVISION

I hereby certify that this plan, specification, or report was prepared by me or under my direct supervision and that I am a duly Licensed Professional Engineer under the laws of the State of Minnesota.  
Bruce Westby  
Date: 4/3/18 Lic. No. 40116

DESIGNED BY: JJF	DATE: 4/3/18
DRAWN BY: JJF	FILE NO.:
CHECKED BY: BRW	18-03

CITY OF RAMSEY  
7550 SUNWOOD DRIVE  
RAMSEY, MN 55303  
(763) 427-1410 FAX (763) 433-9898

MNDOT PED RAMP DETAILS

2018 STREET OVERLAY IMPROVEMENTS  
CITY PROJECT NO. 18-03  
CITY OF RAMSEY, MINNESOTA

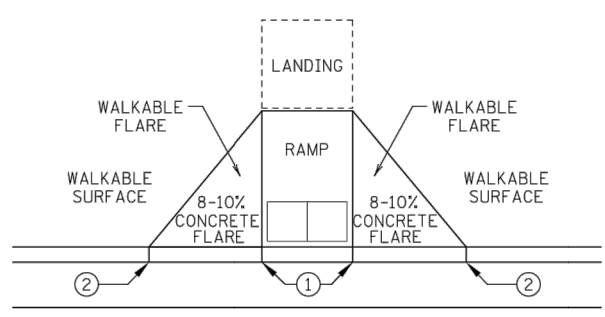

PAVED FLARES ADJACENT TO WALKABLE SURFACE

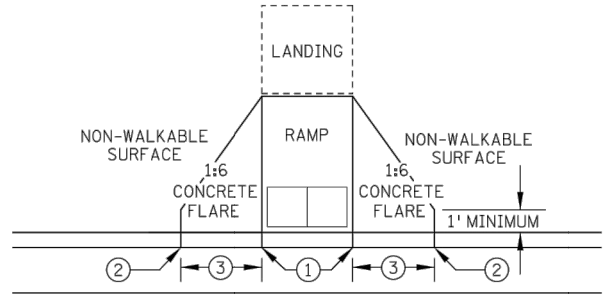

PAVED FLARES ADJACENT TO NON-WALKABLE SURFACE

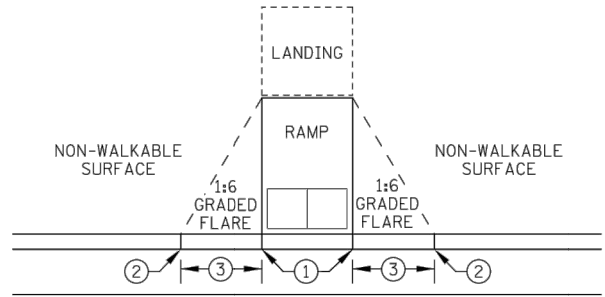

GRADED FLARES

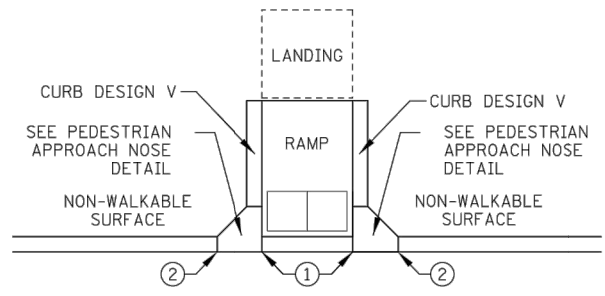

RETURNED CURB ⑤

TYPICAL SIDE TREATMENT OPTIONS ④ ⑪

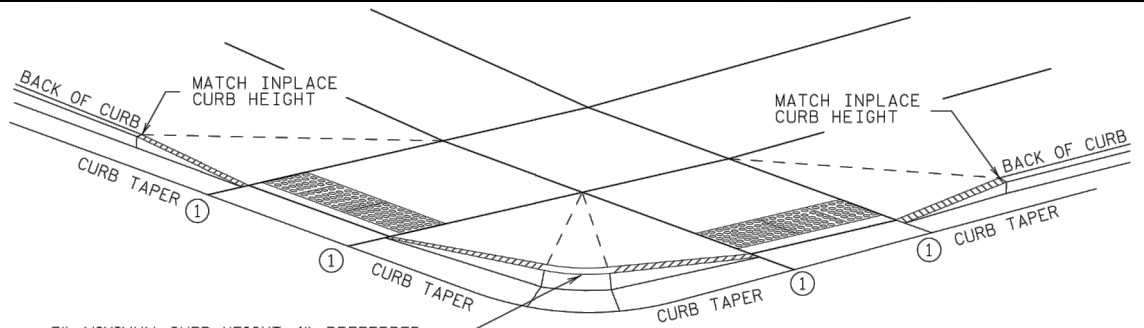

3" MINIMUM CURB HEIGHT, 4" PREFERRED (MEASURED AT FRONT FACE OF CURB) FOR A MIN. 6" LENGTH (MEASURED ALONG FLOW LINE)

DETECTABLE EDGE WITH ⑧ CURB AND GUTTER

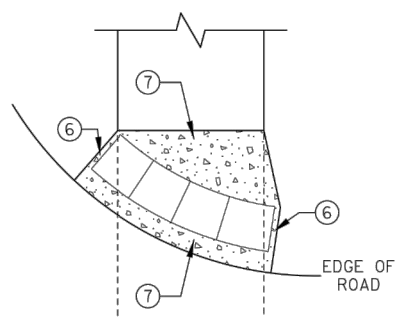

RADIAL DETECTABLE WARNING

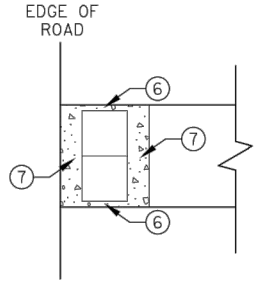

RECTANGULAR DETECTABLE WARNING

DETECTABLE EDGE WITHOUT CURB AND GUTTER

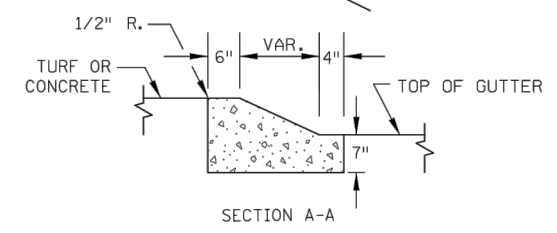
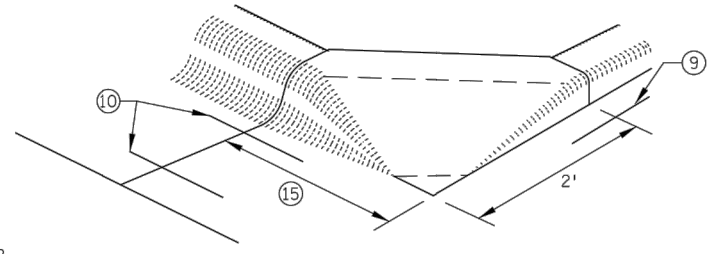

SECTION A-A

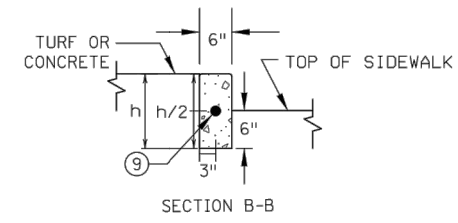

SECTION B-B

PEDESTRIAN APPROACH NOSE DETAIL (FOR RETURNED CURB SIDE TREATMENT)

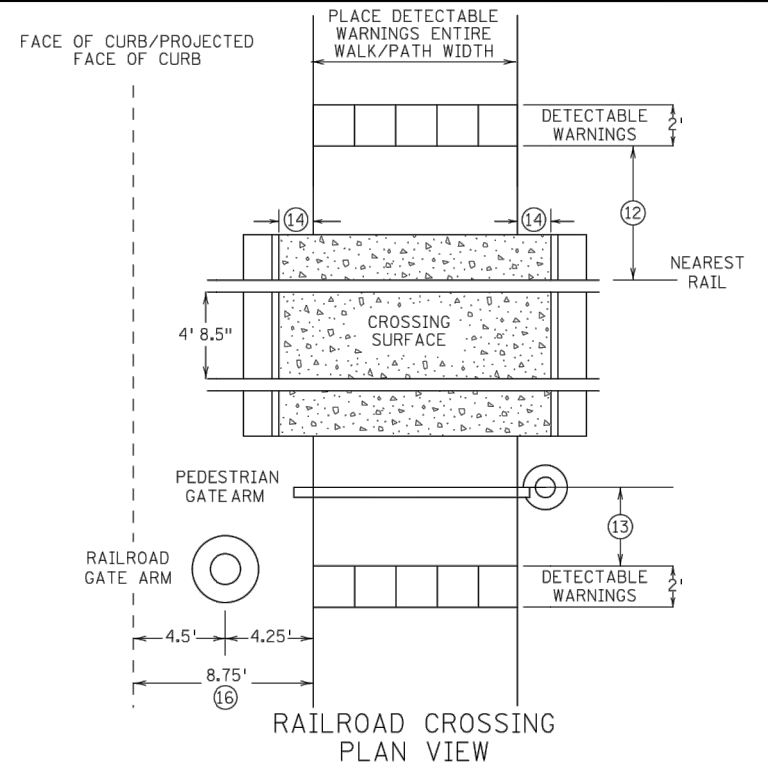

RAILROAD CROSSING PLAN VIEW

NOTES:

- SEE STANDARD PLATE 7038 AND THIS SHEET FOR ADDITIONAL DETAILS ON DETECTABLE WARNING.
- A WALKABLE SURFACE IS DEFINED AS A PAVED SURFACE ADJACENT TO A CURB RAMP WITHOUT RAISED OBSTACLES THAT COULD MISTAKENLY BE TRAVERSED BY A USER WHO IS VISUALLY IMPAIRED.
- CONCRETE FLARE LENGTHS ADJACENT TO NON-WALKABLE SURFACES SHOULD BE LESS THAN 8' LONG MEASURED ALONG THE RAMPS FROM THE BACK OF CURB.
- ① 0" CURB HEIGHT.
- ② FULL CURB HEIGHT.
- ③ 2' FOR 4" HIGH CURB AND 3' FOR 6" HIGH CURB.
- ④ SIDE TREATMENTS ARE APPLICABLE TO ALL RAMP TYPES AND SHOULD BE IMPLEMENTED AS NEEDED AS FIELD CONDITIONS DICTATE. THE ENGINEER SHALL DETERMINE THE RAMP SIDE TREATMENTS BASED ON MAINTENANCE OF BOTH ROADWAY AND SIDEWALK, ADJACENT PROPERTY CONSIDERATIONS, AND MITIGATING CONSTRUCTION IMPACTS.
- ⑤ TYPICALLY USED FOR MEDIANS AND ISLANDS.
- ⑥ WHEN NO CONCRETE FLARES ARE PROPOSED, THE CONCRETE WALK SHALL BE FORMED AND CONSTRUCTED PERPENDICULAR TO THE EDGE OF ROADWAY. MAINTAIN 3" MAX. BETWEEN EDGE OF DOMES AND EDGE OF CONCRETE.
- ⑦ IF NO CURB AND GUTTER IS PLACED IN RURAL SECTIONS, DETECTABLE WARNINGS SHALL BE PLACED 1' FROM THE EDGE OF BITUMINOUS ROADWAY AND/OR BITUMINOUS SHARED-USE PATH TO PROVIDE VISUAL CONTRAST.
- ⑧ ALL CONSTRUCTED CURBS MUST HAVE A CONTINUOUS DETECTABLE EDGE FOR THE VISUALLY IMPAIRED. THIS DETECTABLE EDGE REQUIRES DETECTABLE WARNINGS WHEREVER THERE IS ZERO-INCH HIGH CURB. CURB TAPERS ARE CONSIDERED A DETECTABLE EDGE WHEN THE TAPER STARTS WITHIN 3" OF THE EDGE OF THE DETECTABLE WARNINGS AND UNIFORMLY RISES TO A 3-INCH MINIMUM CURB HEIGHT. ANY CURB NOT PART OF A CURB TAPER AND LESS THAN 3 INCHES IN HEIGHT IS NOT CONSIDERED A DETECTABLE EDGE AND THEREFORE IS NOT COMPLIANT WITH ACCESSIBILITY STANDARDS.
- ⑨ DRILL AND GROUT 1 - NO. 4 12" LONG REINFORCEMENT BAR (EPOXY COATED) WITH 3" MIN. COVER. REINFORCEMENT BARS ARE NOT NEEDED IF THE APPROACH NOSE IS POURED INTEGRAL WITH THE V CURB.
- ⑩ DRILL AND GROUT 2 - NO. 4 12" LONG REINFORCEMENT BARS (EPOXY COATED) WITH 3" MIN. COVER. REINFORCEMENT BARS ARE NOT NEEDED IF THE APPROACH NOSE IS POURED INTEGRAL WITH THE CURB AND GUTTER.
- ⑪ SIDE TREATMENT EXAMPLES SHOWN ARE WHEN THE INITIAL LANDING IS APPROXIMATELY LEVEL WITH THE FULL HEIGHT CURB (I.E. 6' LONG RAMP FOR 6" HIGH CURB). WHEN THE INITIAL LANDING IS MORE THAN 1" BELOW FULL HEIGHT CURB REFER TO SHEETS 1 & 2 TO MODIFY THE CURB HEIGHT TAPERS AND MAINTAIN POSITIVE BOULEVARD DRAINAGE.
- ⑫ NEAREST EDGE OF DETECTABLE WARNING SURFACES SHALL BE PLACED 12' MINIMUM TO 15' MAXIMUM FROM THE NEAREST RAIL. FOR SKEWED RAILWAYS IN NO INSTANCE SHALL THE DETECTABLE WARNING BE CLOSER THAN 12' MEASURED PERPENDICULAR TO THE NEAREST RAIL.
- ⑬ WHEN PEDESTRIAN GATES ARE PROVIDED, DETECTABLE WARNING SURFACES SHALL BE PLACED ON THE SIDE OF THE GATES OPPOSITE THE RAIL, 2' FROM THE APPROACHING SIDE OF THE GATE ARM. THIS CRITERIA GOVERNS OVER NOTE ⑫.
- ⑭ CROSSING SURFACE SHALL EXTEND 2' MINIMUM PAST THE OUTSIDE EDGE OF WALK OR SHARED-USE PATH.
- ⑮ 3' FOR MEDIANS AND SPLITTER ISLANDS. NOSE CAN BE REDUCED TO 2' ON FREE RIGHT ISLANDS.
- ⑯ SIDEWALK TO BE PLACED 8.75' MIN. FROM THE FACE OF CURB/PROJECTED FACE OF CURB. THIS ENSURES MIN. CLEARANCE BETWEEN THE SIDEWALK AND GATE ARM COUNTERWEIGHT SUPPORTS.

REVISION:
APPROVED: JANUARY 23, 2017
<i>Bruce Westby</i> OPERATIONS ENGINEER

MINNESOTA DEPARTMENT OF TRANSPORTATION

REVISOR:

APPROVED: *Tom Sh...* 1-23-2017  
STATE DESIGN ENGINEER

PEDESTRIAN CURB RAMP DETAILS

STANDARD PLAN 5-297.250 4 OF 6

DATE	REVISION

I hereby certify that this plan, specification, or report was prepared by me or under my direct supervision and that I am a duly Licensed Professional Engineer under the laws of the State of Minnesota

*Bruce Westby*  
Bruce Westby  
Date: 4/3/18 Lic. No. 40116

DESIGNED BY: JJJ	DATE: 4/3/18
DRAWN BY: JJJ	FILE No. 18-03
CHECKED BY: BRW	

CITY OF RAMSEY  
7550 SUNWOOD DRIVE  
RAMSEY, MN 55303  
(763) 427-1410 FAX (763) 433-9898

MNDOT PED RAMP DETAILS

2018 STREET OVERLAY IMPROVEMENTS  
CITY PROJECT NO. 18-03  
CITY OF RAMSEY, MINNESOTA

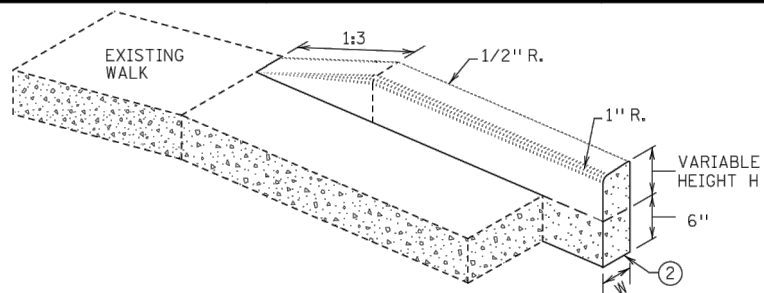

V CURB ADJACENT TO LANDSCAPE  
CURB WITHIN SIDEWALK LIMITS

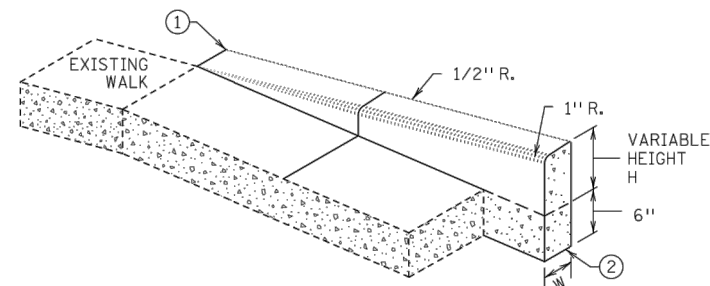

V CURB ADJACENT TO LANDSCAPE  
CURB OUTSIDE SIDEWALK LIMITS

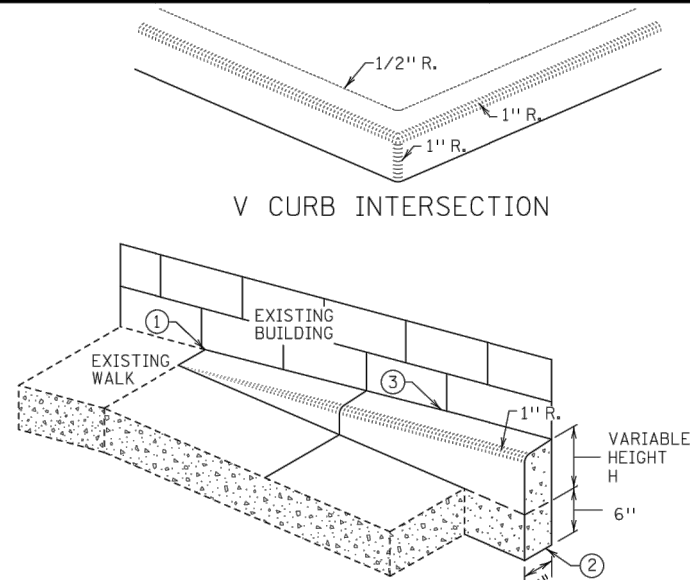

V CURB ADJACENT TO BUILDING  
OR BARRIER

CONCRETE CURB DESIGN V	
CURB HEIGHT H	CURB WIDTH W
< 6"	4"
≥ 6"	6"

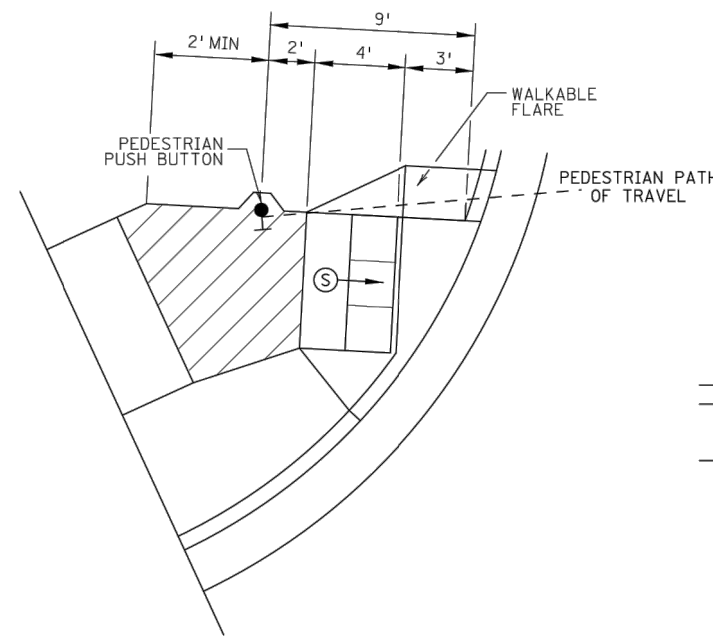

SEMI-DIRECTIONAL RAMP (3,4,9)

3' DOME SETBACK, 4' LONG RAMP AND  
PUSH BUTTON 9' FROM THE BACK OF CURB

PRIMARYLY USED FOR APS APPLICATIONS  
WHERE THE PAR DOES NOT CONTINUE PAST  
THE PUSH BUTTON (DEAD-END SIDEWALK)

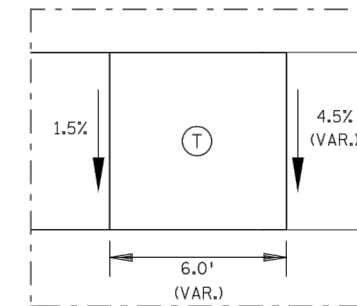
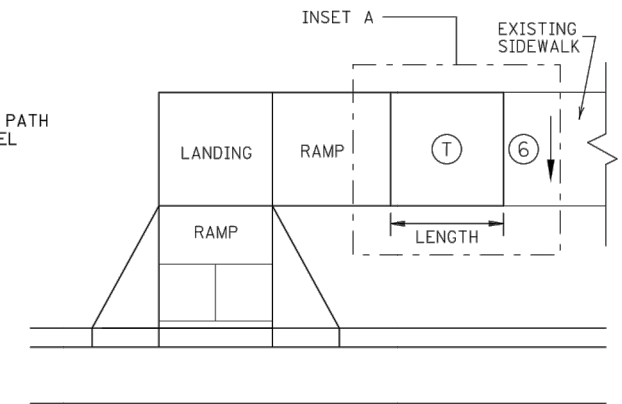

INSET A  
TRANSITION PANEL (4,5)

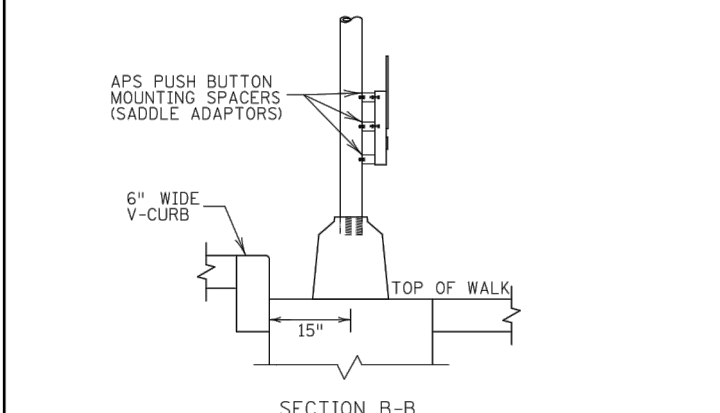
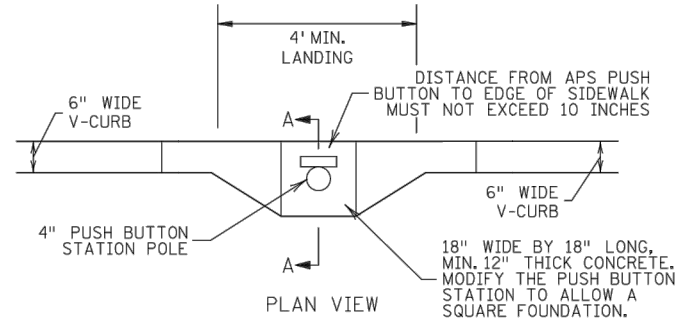
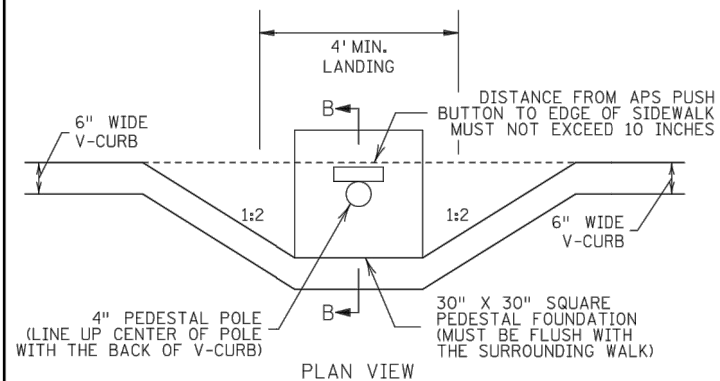

SIGNAL PEDESTAL & PUSH BUTTON (V-CURB)

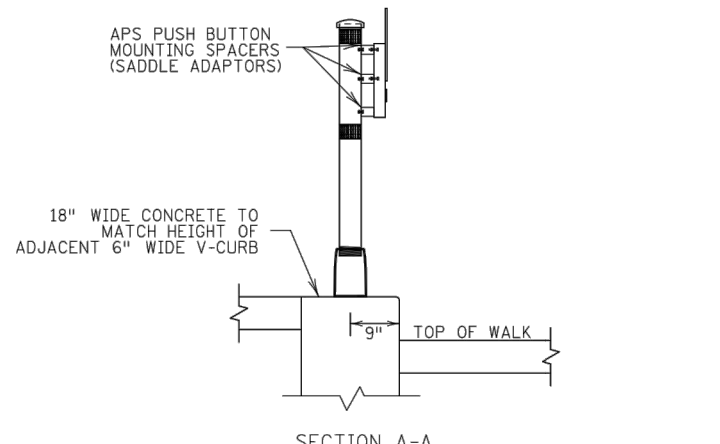

PUSH BUTTON STATION (V-CURB)

NOTES:

- A WALKABLE FLARE IS AN 8-10% CONCRETE FLARE THAT IS REQUIRED WHEN THE FLARE IS ADJACENT TO A WALKABLE SURFACE, OR WHEN THE PEDESTRIAN PATH OF TRAVEL OF A PUSH BUTTON TRAVERSES THE FLARE.
- ALL V CURB CONTRACTION JOINTS SHALL MATCH CONCRETE WALK JOINTS.
- WHERE RIGHT-OF-WAY ALLOWS, USE OF V CURB SHOULD BE MINIMIZED. GRADING ADJACENT TURF OR SLOPING ADJACENT PAVEMENT IS PREFERRED.
- V CURB SHALL BE PLACED OUTSIDE THE SIDEWALK LIMITS WHEN RIGHT OF WAY ALLOWS.
- V CURB NEXT TO BUILDING SHALL BE A 4" WIDTH AND SHALL MATCH PREVIOUS TOP OF SIDEWALK ELEVATIONS.
- ① END TAPERS AT TRANSITION SECTION SHALL MATCH INPLACE SIDEWALK GRADES.
- ② ALL V CURB SHALL MATCH BOTTOM OF ADJACENT WALK.
- ③ EDGE BETWEEN NEW V CURB AND INPLACE STRUCTURE SHALL BE SEALED AND BOND BREAKER SHALL BE USED BETWEEN EXISTING STRUCTURE AND PLACED V-CURB.
- ④ THE MAX. RATE OF CROSS SLOPE TRANSITIONING IS 1' LINEAR FOOT OF SIDEWALK PER HALF PERCENT CROSS SLOPE. WHEN PAR WIDTH IS GREATER THAN 6' OR THE RUNNING SLOPE IS GREATER THAN 5%, DOUBLE THE CALCULATED TRANSITION LENGTH.
- ⑤ TRANSITION PANELS ARE TO ONLY BE USED AFTER THE RAMP, OR IF NEEDED, LANDING ARE AT THE FULL CURB HEIGHT (TYPICAL SECTION).
- ⑥ EXISTING CROSS SLOPE GREATER THAN 2.0%.

LEGEND

THESE LONGITUDINAL SLOPE RANGES SHALL BE THE STARTING POINT. IF SITE CONDITIONS WARRANT, LONGITUDINAL SLOPES UP TO 8.3% OR FLATTER ARE ALLOWED.

- ⑤ INDICATES PEDESTRIAN RAMP - SLOPE SHALL BE BETWEEN 5.0% MINIMUM AND 8.3% MAXIMUM IN THE DIRECTION SHOWN AND THE CROSS SLOPE SHALL NOT EXCEED 2.0%.
- ▨ LANDING AREA - 4' X 4' MIN. (5' X 5' MIN. PREFERRED) DIMENSIONS AND MAX 2.0% SLOPE IN ALL DIRECTIONS. LANDING SHALL BE FULL WIDTH OF INCOMING PARS.
- ④ TRANSITION PANEL(S) - TO BE USED FOR TRANSITIONING THE CROSS-SLOPE OF A RAMP TO THE EXISTING WALK CROSS-SLOPE. RATE OF TRANSITION SHOULD BE 0.5% PER 1 LINEAR FOOT OF WALK. SEE THIS SHEET FOR ADDITIONAL INFORMATION.

REVISION:  
APPROVED: JANUARY 23, 2017  
OPERATIONS ENGINEER

REVISOR:  
APPROVED: 1-23-2017  
STATE DESIGN ENGINEER

PEDESTRIAN CURB RAMP DETAILS  
STANDARD PLAN 5-297.250 5 OF 6

DATE	REVISION

I hereby certify that this plan, specification, or report was prepared by me or under my direct supervision and that I am a duly Licensed Professional Engineer under the laws of the State of Minnesota.  
Bruce Westby  
Date: 4/3/18 Lic. No. 40116

DESIGNED BY: JJJ  
DRAWN BY: JJJ  
CHECKED BY: BRW  
DATE: 4/3/18  
FILE NO.: 18-03

CITY OF RAMSEY  
7550 SUNWOOD DRIVE  
RAMSEY, MN 55303  
(763) 427-1410 FAX (763) 433-9898

MNDOT PED RAMP DETAILS

2018 STREET OVERLAY IMPROVEMENTS  
CITY PROJECT NO. 18-03  
CITY OF RAMSEY, MINNESOTA

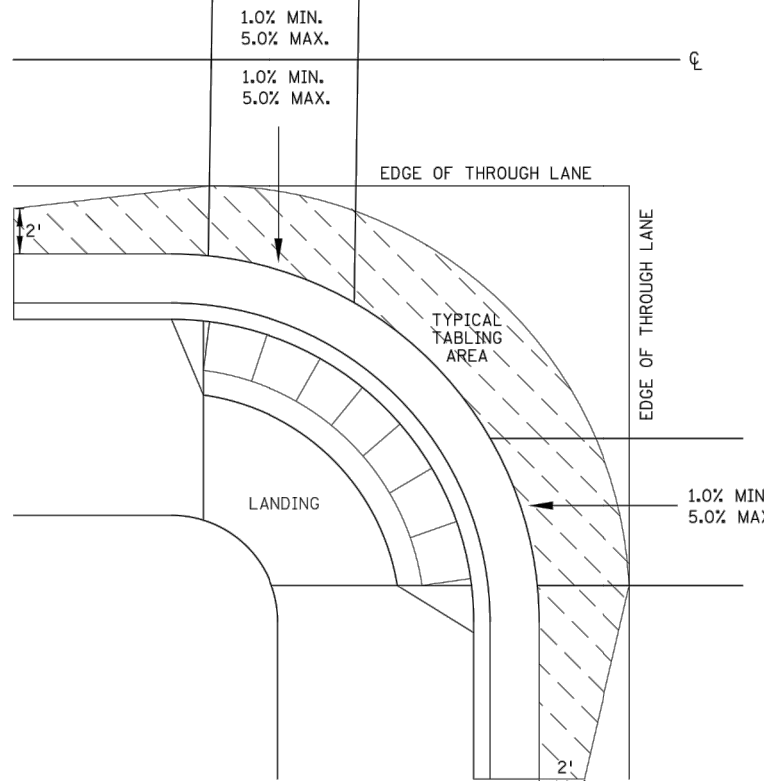
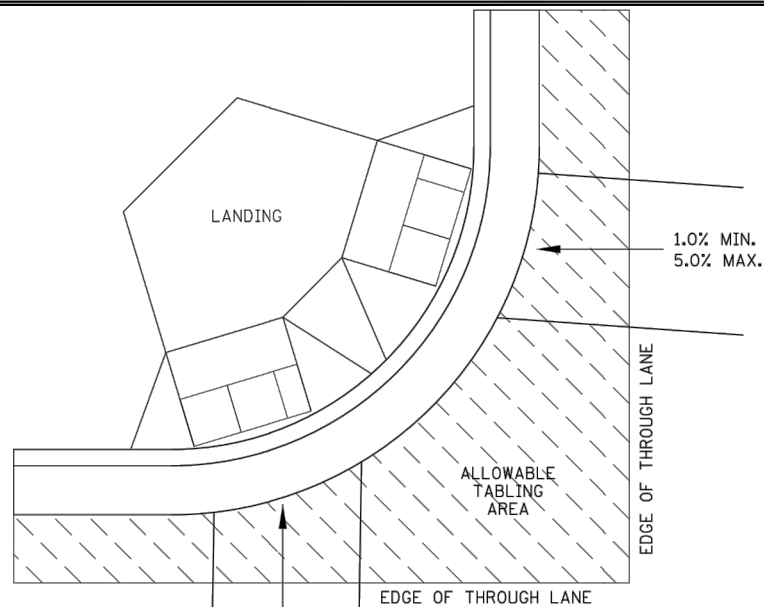

CURB LINE AND ROAD CROSSING ADJUSTMENTS

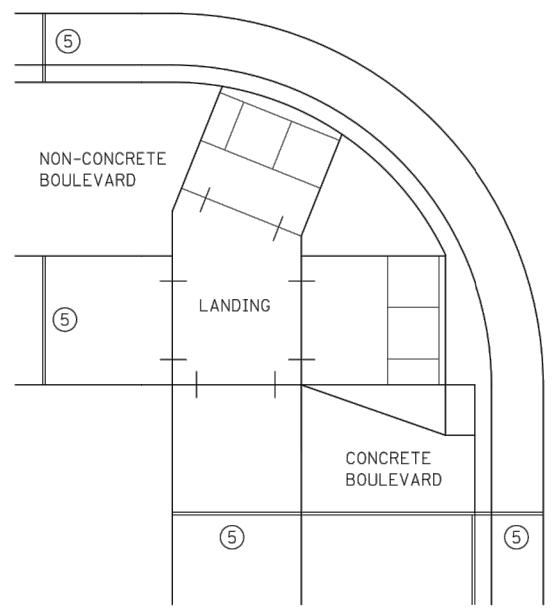

EXPANSION MATERIAL PLACEMENT FOR CONCRETE AND BITUMINOUS ROADWAYS

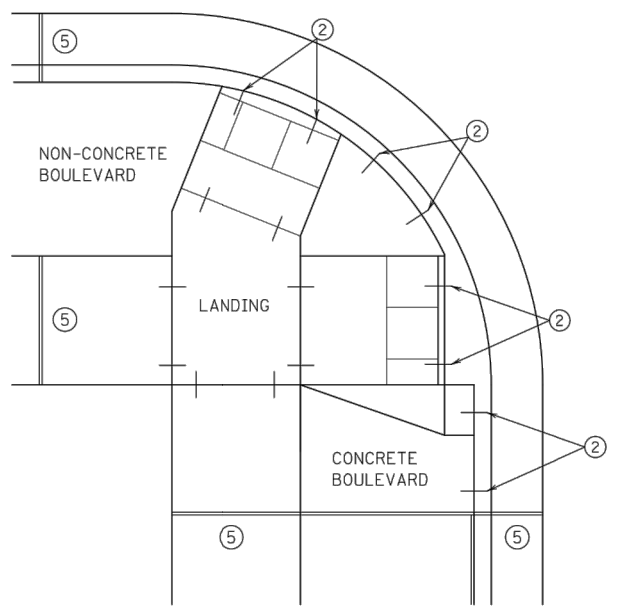

OPTIONAL CURB LINE REINFORCEMENT PLACEMENT ON BITUMINOUS ROADWAYS

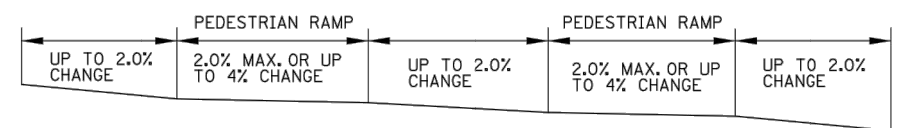

FLOW LINE PROFILE "TABLE" - TWIN PERPENDICULARS

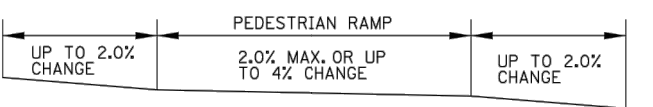

FLOW LINE PROFILE "TABLE" - FAN

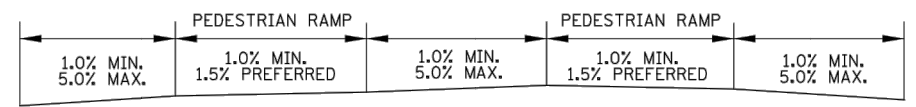

FLOW LINE PROFILE RAISE - TWIN PERPENDICULARS

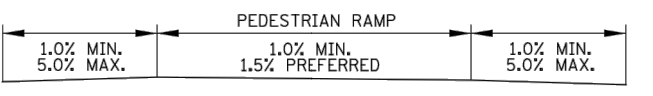

FLOW LINE PROFILE RAISE - FAN

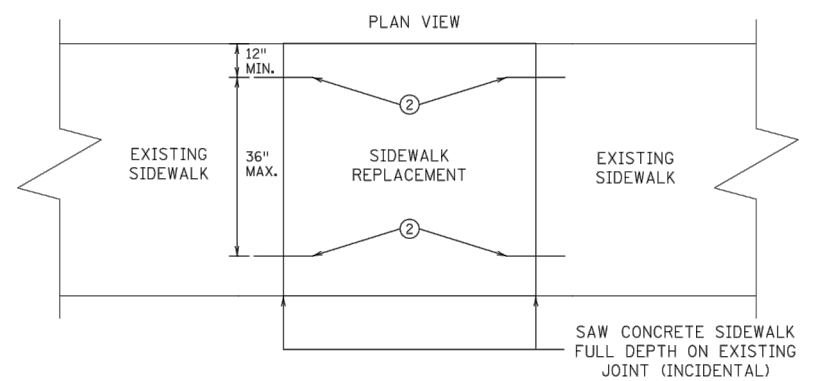

OPTIONAL SIDEWALK REINFORCEMENT  
SIDEWALK REINFORCEMENT TO BE USED ONLY WHEN SPECIFIED IN THE PLAN.

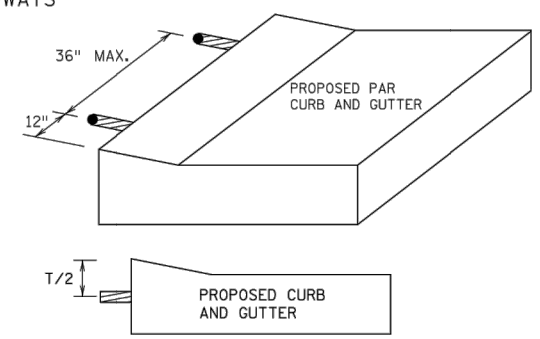

OPTIONAL CURB LINE REINFORCEMENT DETAILS

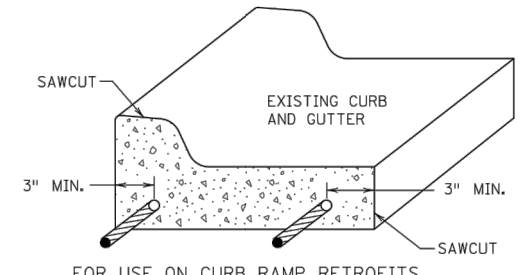

CURB AND GUTTER REINFORCEMENT

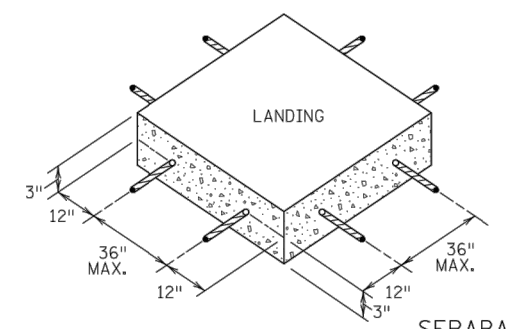

SEPARATE LANDING POUR REINFORCEMENT

"TABLING" OF CROSSWALKS MEANS MAINTAINING LESS THAN 2% CROSS SLOPE WITHIN A CROSSWALK, IS REQUIRED WHEN A ROADWAY IS IN A STOP OR YIELD CONDITION AND THE PROJECT SCOPE ALLOWS.

RECONSTRUCTION PROJECTS: ON FULL PAVEMENT REPLACEMENT PROJECTS "TABLING" OF ENTIRE CROSSWALK SHALL OCCUR WHEN FEASIBLE.

MILL & OVERLAY PROJECTS: "TABLING" OF FLOW LINES, IN FRONT OF THE PEDESTRIAN RAMP, IS REQUIRED WHEN THE EXISTING FLOW LINE IS GREATER THAN 2%. WARPING OF THE BITUMINOUS PAVEMENT CAN NOT EXTEND INTO THE THROUGH LANE. TABLE THE FLOW LINE TO 2% OR AS MUCH AS POSSIBLE WHILE ADHERING TO THE FOLLOWING CRITERIA:

- 1) 1.0% MIN. CROSS-SLOPE OF THE ROAD
- 2) 5.0% MAX. CROSS-SLOPE OF THE ROAD
- 3) "TABLE" FLOW LINE UP TO 4% CHANGE FROM EXISTING SLOPE IN FRONT OF PEDESTRIAN RAMP
- 4) UP TO 2% CHANGE IN FLOW LINE FROM EXISTING SLOPE BEYOND THE PEDESTRIAN CURB RAMP

STAND-ALONE ADA RETROFITS: FOLLOW MILL & OVERLAY CRITERIA ABOVE HOWEVER ALL PAVEMENT WARPING IS DONE WITH BITUMINOUS PATCHING ON BITUMINOUS ROADWAYS AND FULL-DEPTH APRON REPLACEMENT ON CONCRETE ROADWAYS.

RAISING OF CURB LINES SHOULD OCCUR IN VERTICALLY CONSTRAINED AREAS. RAISE THE CURB LINES ENOUGH TO ALLOW COMPLIANT RAMPS OR AS MUCH AS POSSIBLE WHILE ADHERING TO THE FOLLOWING CRITERIA:

- 1) 1.0% MIN. AND 5.0% MAXIMUM CROSS-SLOPE OF THE ROAD
- 2) 1.0% MIN. FLOW LINE (ON EITHER SIDE OF PEDESTRIAN RAMP) TO MAINTAIN POSITIVE DRAINAGE
- 3) 5.0% RECOMMENDED MAX. FLOW LINE
- 4) LONGITUDINAL THROUGH LANE ROADWAY TAPERS SHOULD BE 1" VERTICAL PER 15' HORIZONTAL

NOTES:

- ① TO ENSURE RAMPS AND LANDINGS ARE PROPERLY CONSTRUCTED, ALL INITIAL LANDINGS AT A TOP OF A RAMPED SURFACE (RUNNING SLOPE GREATER THAN 2%) SHALL BE FORMED AND PLACED SEPARATELY IN AN INDEPENDENT CONCRETE POUR. FOLLOW SIDEWALK REINFORCEMENT DETAILS ON THIS SHEET FOR ALL SEPARATELY POURED INITIAL LANDINGS.
- ② DRILL AND GROUT NO. 4 12" LONG REINFORCEMENT BARS AT 36" MAXIMUM CENTER TO CENTER (EPOXY COATED). BARS TO BE ADJUSTED TO MATCH RAMP GRADE.
- ③ DRILL AND GROUT 2 - NO. 4 X 12" LONG REINFORCEMENT BARS (EPOXY COATED). REINFORCEMENT REQUIRED FOR ALL CONSTRUCTION JOINTS WITHIN RADIUS.
- ④ THIS OPTIONAL CURB LINE REINFORCEMENT DETAIL SHOULD ONLY BE USED ON BITUMINOUS ROADWAYS WHEN SPECIFIED IN THE PLAN.
- ⑤ 1/2 IN. PREFORMED JOINT FILLER MATERIAL PER MNDOT SPEC. 3702.

REVISION:
APPROVED: JANUARY 23, 2017
OPERATIONS ENGINEER

MINNESOTA DEPARTMENT OF TRANSPORTATION

REVISOR: \_\_\_\_\_

APPROVED: *Rom Sh...* 1-23-2017

STATE DESIGN ENGINEER

PEDESTRIAN CURB RAMP DETAILS

STANDARD PLAN 5-297.250

6 OF 6

DATE	REVISION

I hereby certify that this plan, specification, or report was prepared by me or under my direct supervision and that I am a duly Licensed Professional Engineer under the laws of the State of Minnesota.

*Bruce Westby*  
Bruce Westby  
Date: 4/3/18 Lic. No. 40116

DESIGNED BY: JJF	DATE: 4/3/18
DRAWN BY: JJF	FILE NO. 18-03
CHECKED BY: BRW	





CITY OF RAMSEY  
7550 SUNWOOD DRIVE  
RAMSEY, MN 55303  
(763) 427-1410 FAX (763) 433-9898

MNDOT PED RAMP DETAILS

2018 STREET OVERLAY IMPROVEMENTS  
CITY PROJECT NO. 18-03  
CITY OF RAMSEY, MINNESOTA

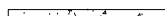

**LEGEND**

-  OVERLAY AREA
-  MATCH-IN MILL - 2' X 2.0"
-  EDGE MILL - 7' X (0"-2")
-  6" THICK CONCRETE WALK
-  SAWCUT PAVEMENT - FULL DEPTH
-  RESET CATCH BASIN / MANHOLE

NOTE: RESET CATCH BASIN / MANHOLE INCLUDES GROUTING THE STRUCTURE AND ANY ADJUSTS REQUIRED PRIOR TO MILLING AND/OR AFTER PAVING OPERATIONS. GROUTING OF THE STRUCTURE SHALL NOT OCCUR UNTIL AFTER PAVING OPERATIONS.

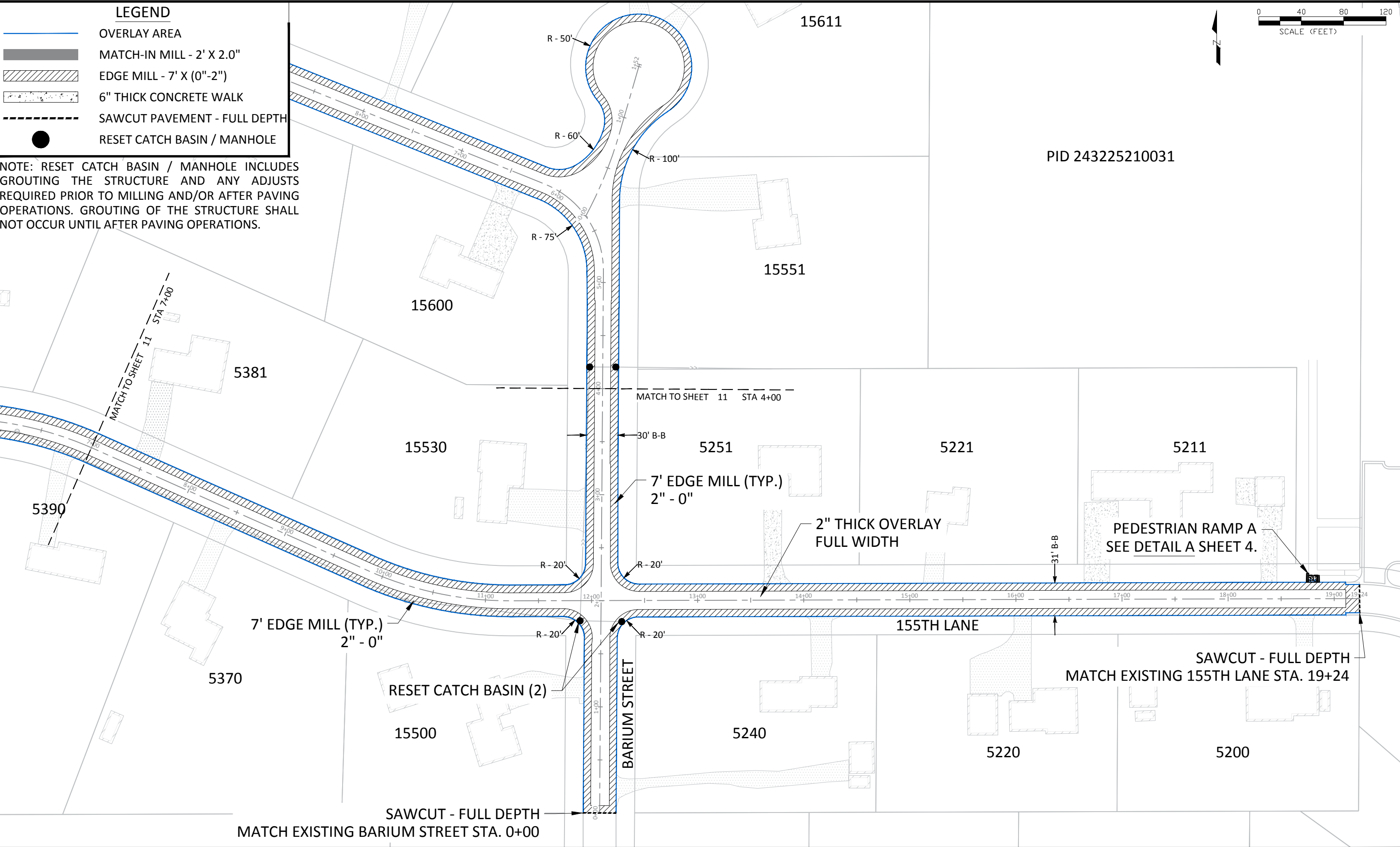

DATE	REVISION

I hereby certify that this plan, specification, or report was prepared by me or under my direct supervision and that I am a duly Licensed Professional Engineer under the laws of the State of Minnesota.

*Bruce Westby*  
 Bruce Westby  
 Lic. No. 40116

DESIGNED BY: JJF  
 DRAWN BY: JJF  
 CHECKED BY: BRW

DATE: 4/3/18  
 FILE No. 18-03

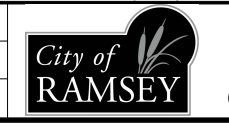

CITY OF RAMSEY  
 7550 SUNWOOD DRIVE  
 RAMSEY, MN 55303  
 (763) 427-1410 FAX (763) 433-9898

WOODLAND GREEN OVERLAY

2018 STREET OVERLAY IMPROVEMENTS  
 CITY PROJECT NO. 18-03  
 CITY OF RAMSEY, MINNESOTA



15768 15779

15750

15757

15731

15700

OKAPI STREET

2" THICK OVERLAY

31' B-B





MATCH TO SHEET 14 STA 7+00

PID 173225340016

REMOVE BITUMINOUS PAVEMENT (74 SY)  
REPLACE WITH 4" TOPSOIL AND SOD

SAWCUT - FULL DEPTH  
MILL PAVEMENT 2' WIDE X 2" DEEP  
MATCH INTO OKAPI STREET STA. 0+00

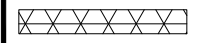
**LEGEND**

-  OVERLAY AREA
-  MATCH-IN MILL - 2' X 2"
-  REMOVE BITUMINOUS PAVEMENT
-  SAWCUT PAVEMENT - FULL DEPTH

DATE	REVISION

I hereby certify that this plan, specification, or report was prepared by me or under my direct supervision and that I am a duly Licensed Professional Engineer under the laws of the State of Minnesota.

*Bruce Westby*  
Bruce Westby  
Date: 4/3/18 Lic. No. 40116

DESIGNED BY: JJF  
DRAWN BY: JJF  
CHECKED BY: BRW  
DATE: 4/3/18  
FILE No. 18-03

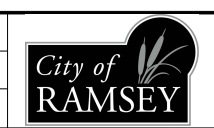

CITY OF RAMSEY  
7550 SUNWOOD DRIVE  
RAMSEY, MN 55303  
(763) 427-1410 FAX (763) 433-9898

THE NORTH FORTY 2ND OVERLAY

2018 STREET OVERLAY IMPROVEMENTS  
CITY PROJECT NO. 18-03  
CITY OF RAMSEY, MINNESOTA

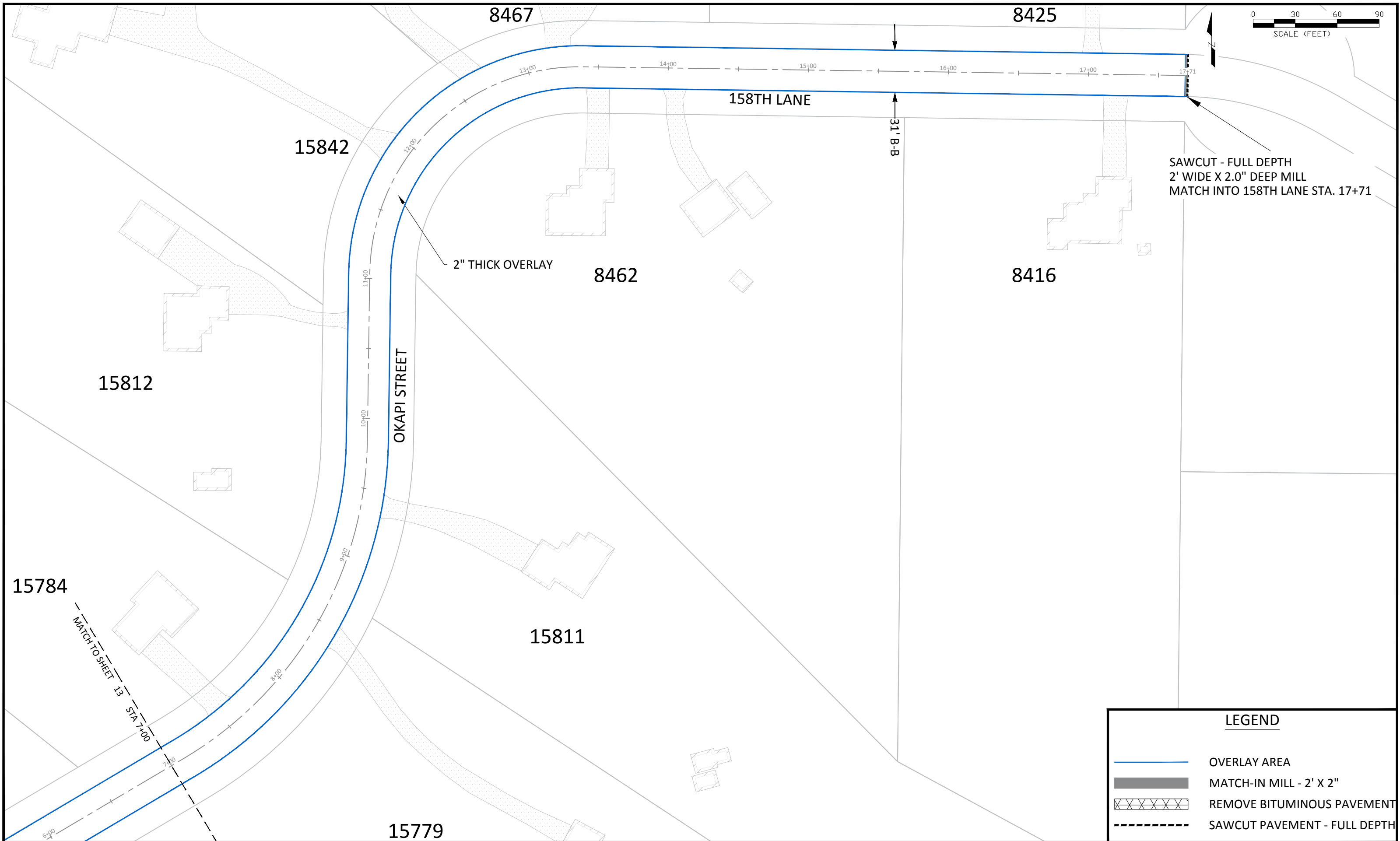
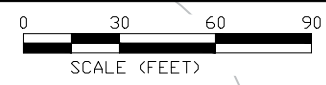

SAWCUT - FULL DEPTH  
2' WIDE X 2.0" DEEP MILL  
MATCH INTO 158TH LANE STA. 17+71

2" THICK OVERLAY

31' B-B

LEGEND	
	OVERLAY AREA
	MATCH-IN MILL - 2' X 2"
	REMOVE BITUMINOUS PAVEMENT
	SAWCUT PAVEMENT - FULL DEPTH

DATE	REVISION

I hereby certify that this plan, specification, or report was prepared by me or under my direct supervision and that I am a duly Licensed Professional Engineer under the laws of the State of Minnesota.

*Bruce Westby*  
Bruce Westby  
Lic. No. 40116

DESIGNED BY: JJF  
DRAWN BY: JJF  
CHECKED BY: BRW  
DATE: 4/3/18  
FILE No. 18-03

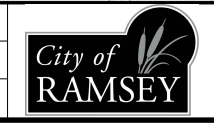

CITY OF RAMSEY  
7550 SUNWOOD DRIVE  
RAMSEY, MN 55303  
(763) 427-1410 FAX (763) 433-9898

THE NORTH FORTY 2ND OVERLAY

2018 STREET OVERLAY IMPROVEMENTS  
CITY PROJECT NO. 18-03  
CITY OF RAMSEY, MINNESOTA

SHEET 14 OF 22 SHEETS

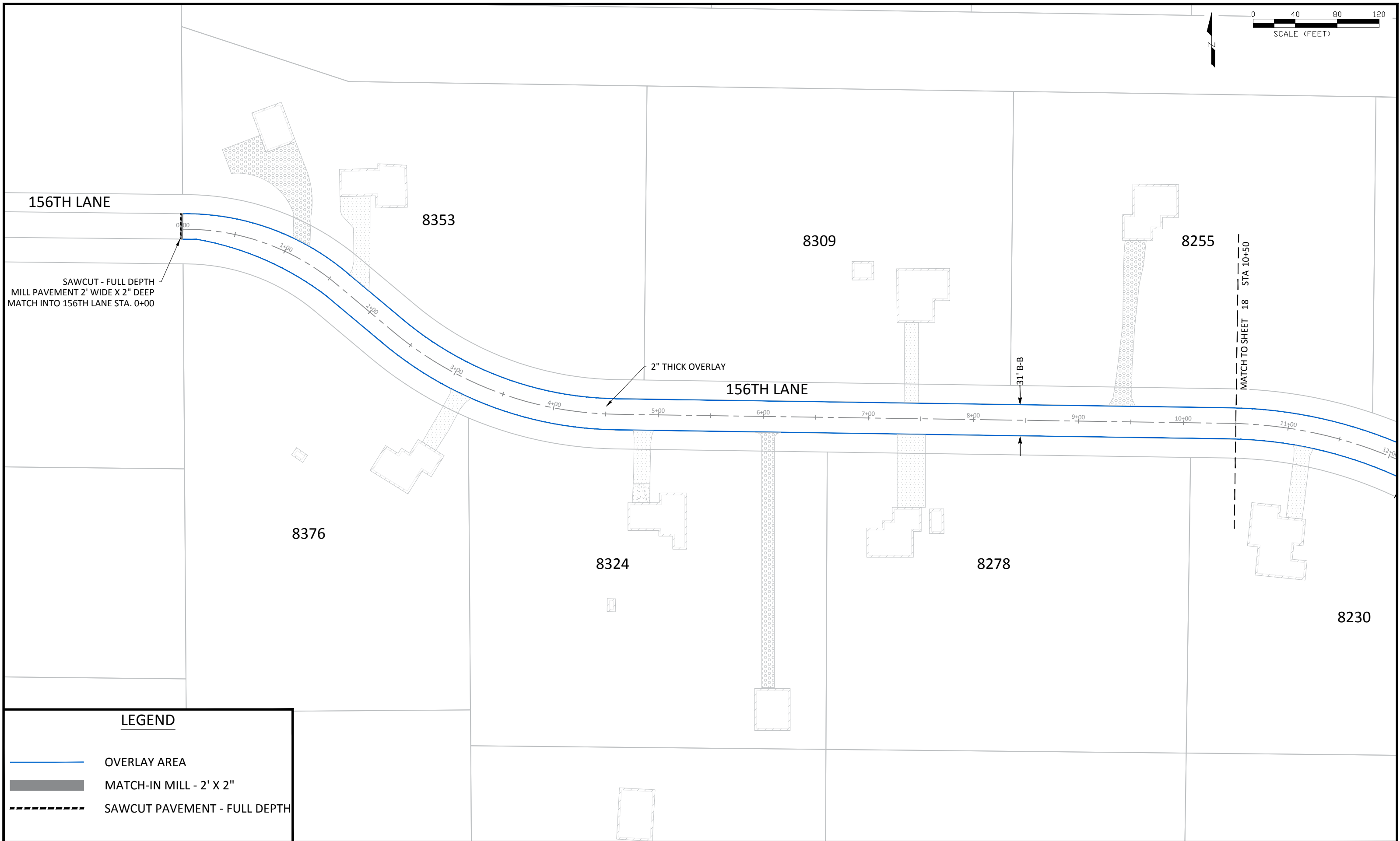

SAWCUT - FULL DEPTH  
MILL PAVEMENT 2' WIDE X 2" DEEP  
MATCH INTO 156TH LANE STA. 0+00

2" THICK OVERLAY

31' B-B

MATCH TO SHEET 18 STA 10+50

**LEGEND**

- OVERLAY AREA
- MATCH-IN MILL - 2' X 2"
- SAWCUT PAVEMENT - FULL DEPTH

DATE	REVISION

I hereby certify that this plan, specification, or report was prepared by me or under my direct supervision and that I am a duly Licensed Professional Engineer under the laws of the State of Minnesota

*Bruce Westby*  
Bruce Westby  
Date: 4/3/18 Lic. No. 40116

DESIGNED BY: JFJ  
DRAWN BY: JFJ  
CHECKED BY: BRW  
DATE: 4/3/18  
FILE No. 18-03

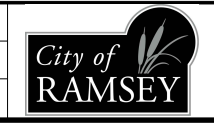

**CITY OF RAMSEY**  
7550 SUNWOOD DRIVE  
RAMSEY, MN 55303  
(763) 427-1410 FAX (763) 433-9898

**THE NORTH FORTY 3RD OVERLAY**

**2018 STREET OVERLAY IMPROVEMENTS**  
CITY PROJECT NO. 18-03  
CITY OF RAMSEY, MINNESOTA

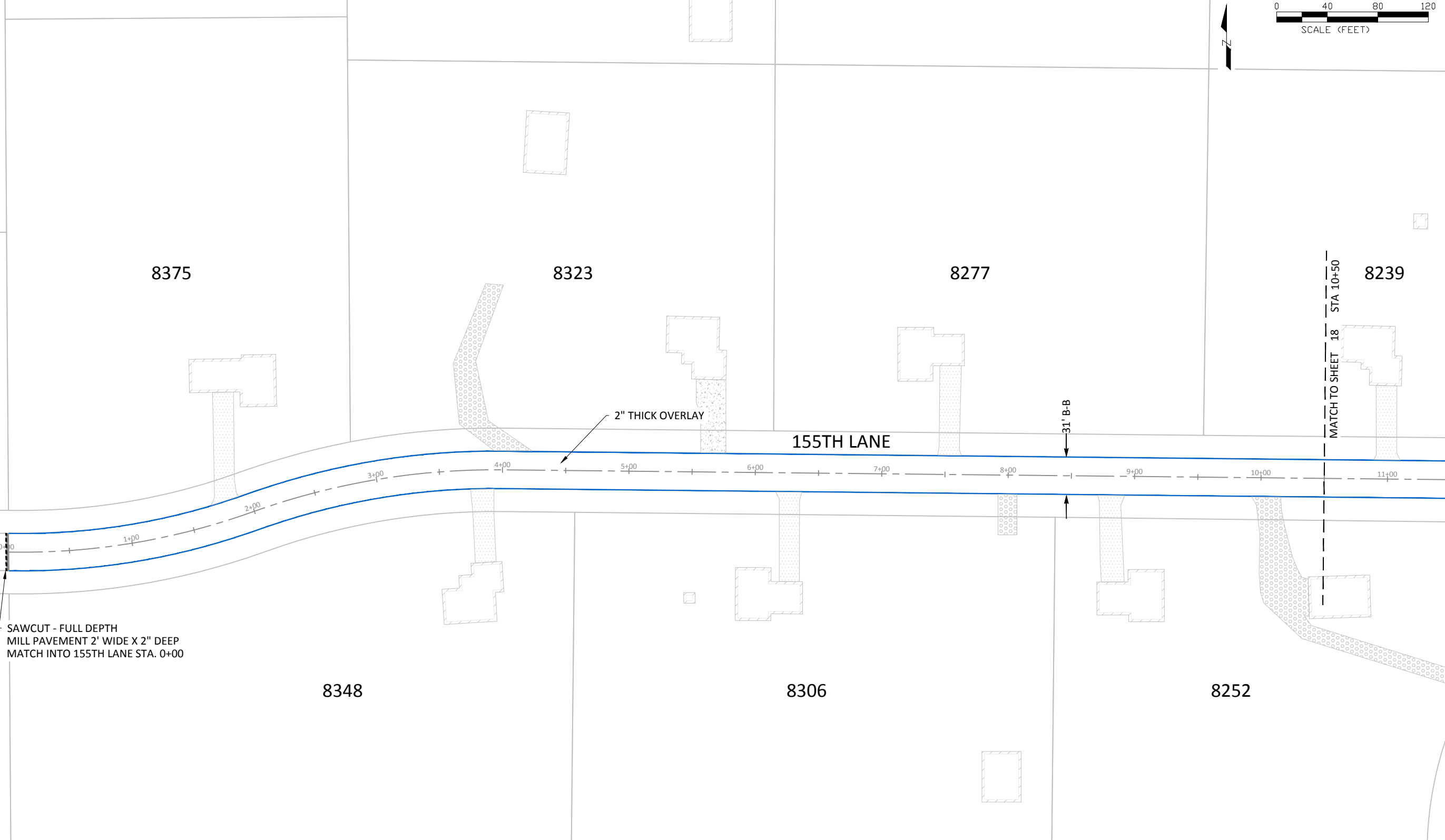

SAWCUT - FULL DEPTH  
MILL PAVEMENT 2' WIDE X 2" DEEP  
MATCH INTO 155TH LANE STA. 0+00

2" THICK OVERLAY

31' B-B

MATCH TO SHEET 18  
STA 10+50

**LEGEND**

- OVERLAY AREA
- MATCH-IN MILL - 2' X 2"
- SAWCUT PAVEMENT - FULL DEPTH

DATE	REVISION

I hereby certify that this plan, specification, or report was prepared by me or under my direct supervision and that I am a duly Licensed Professional Engineer under the laws of the State of Minnesota

*Bruce Westby*  
Bruce Westby  
Date: 4/3/18 Lic. No. 40116

DESIGNED BY: JJF  
DRAWN BY: JJF  
CHECKED BY: BRW  
DATE: 4/3/18  
FILE No. 18-03



CITY OF RAMSEY  
7550 SUNWOOD DRIVE  
RAMSEY, MN 55303  
(763) 427-1410 FAX (763) 433-9898

THE NORTH FORTY 3RD OVERLAY

2018 STREET OVERLAY IMPROVEMENTS  
CITY PROJECT NO. 18-03  
CITY OF RAMSEY, MINNESOTA

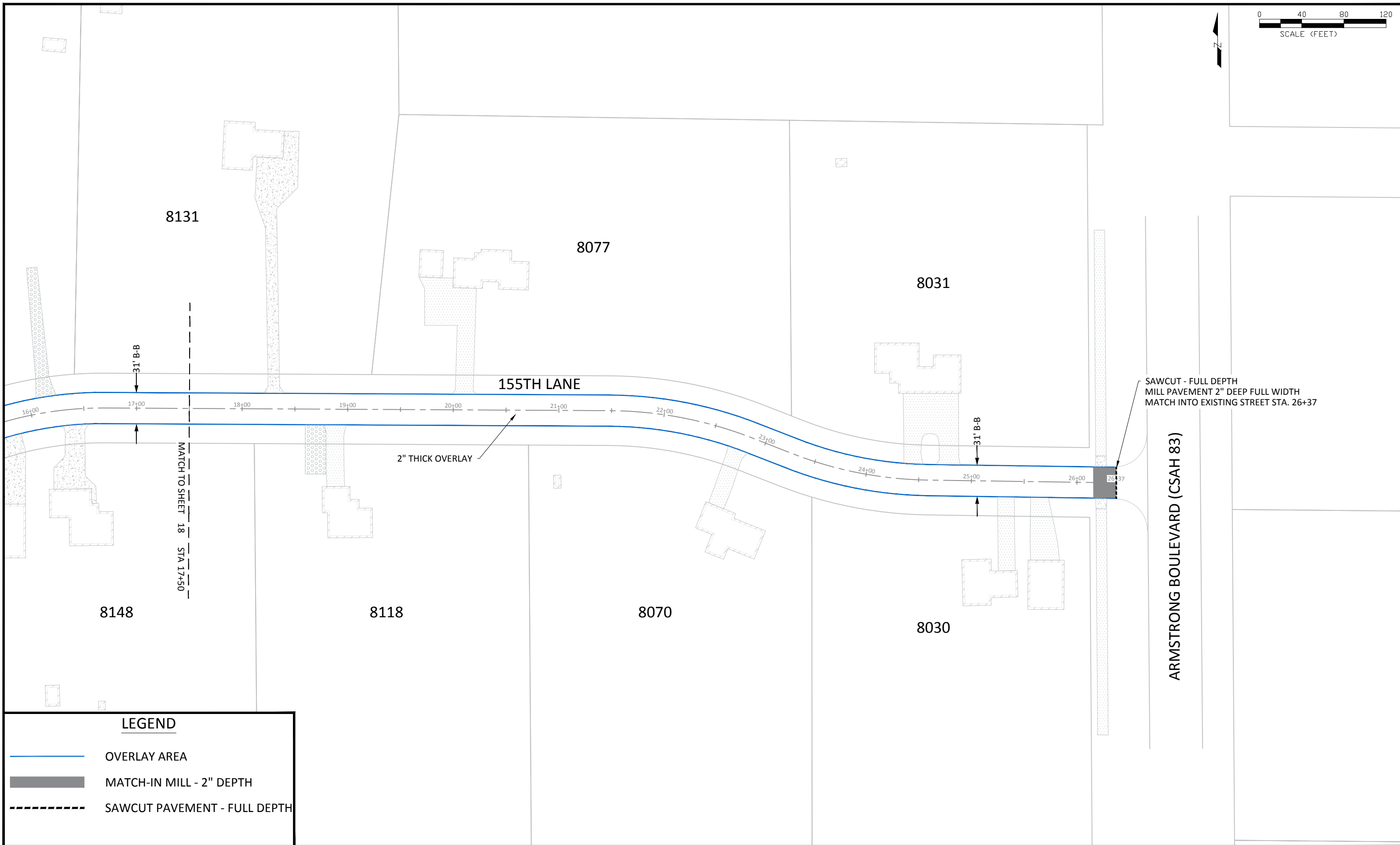

LEGEND	
	OVERLAY AREA
	MATCH-IN MILL - 2" DEPTH
	SAWCUT PAVEMENT - FULL DEPTH

DATE	REVISION

I hereby certify that this plan, specification, or report was prepared by me or under my direct supervision and that I am a duly Licensed Professional Engineer under the laws of the State of Minnesota.

*Bruce Westby*  
Bruce Westby  
Date: 4/3/18 Lic. No. 40116

DESIGNED BY: JJF	DATE: 4/3/18
DRAWN BY: JJF	FILE No. 18-03
CHECKED BY: BRW	

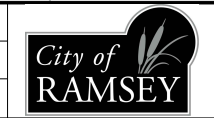

CITY OF RAMSEY  
7550 SUNWOOD DRIVE  
RAMSEY, MN 55303  
(763) 427-1410 FAX (763) 433-9898

THE NORTH FORTY 3RD OVERLAY

2018 STREET OVERLAY IMPROVEMENTS  
CITY PROJECT NO. 18-03  
CITY OF RAMSEY, MINNESOTA



**LEGEND**

- OVERLAY AREA
- MATCH-IN MILL - 2' X 2"
- SAWCUT PAVEMENT - FULL DEPTH

DATE	REVISION

I hereby certify that this plan, specification, or report was prepared by me or under my direct supervision and that I am a duly Licensed Professional Engineer under the laws of the State of Minnesota.

*Bruce Westby*  
 Bruce Westby  
 Date: 4/3/18 Lic. No. 40116

DESIGNED BY: JJF  
 DRAWN BY: JJF  
 CHECKED BY: BRW  
 DATE: 4/3/18  
 FILE No. 18-03

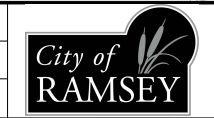

**CITY OF RAMSEY**  
 7550 SUNWOOD DRIVE  
 RAMSEY, MN 55303  
 (763) 427-1410 FAX (763) 433-9898

**THE NORTH FORTY 3RD OVERLAY**

**2018 STREET OVERLAY IMPROVEMENTS**  
**CITY PROJECT NO. 18-03**  
 CITY OF RAMSEY, MINNESOTA

SHEET **18** OF **22** SHEETS

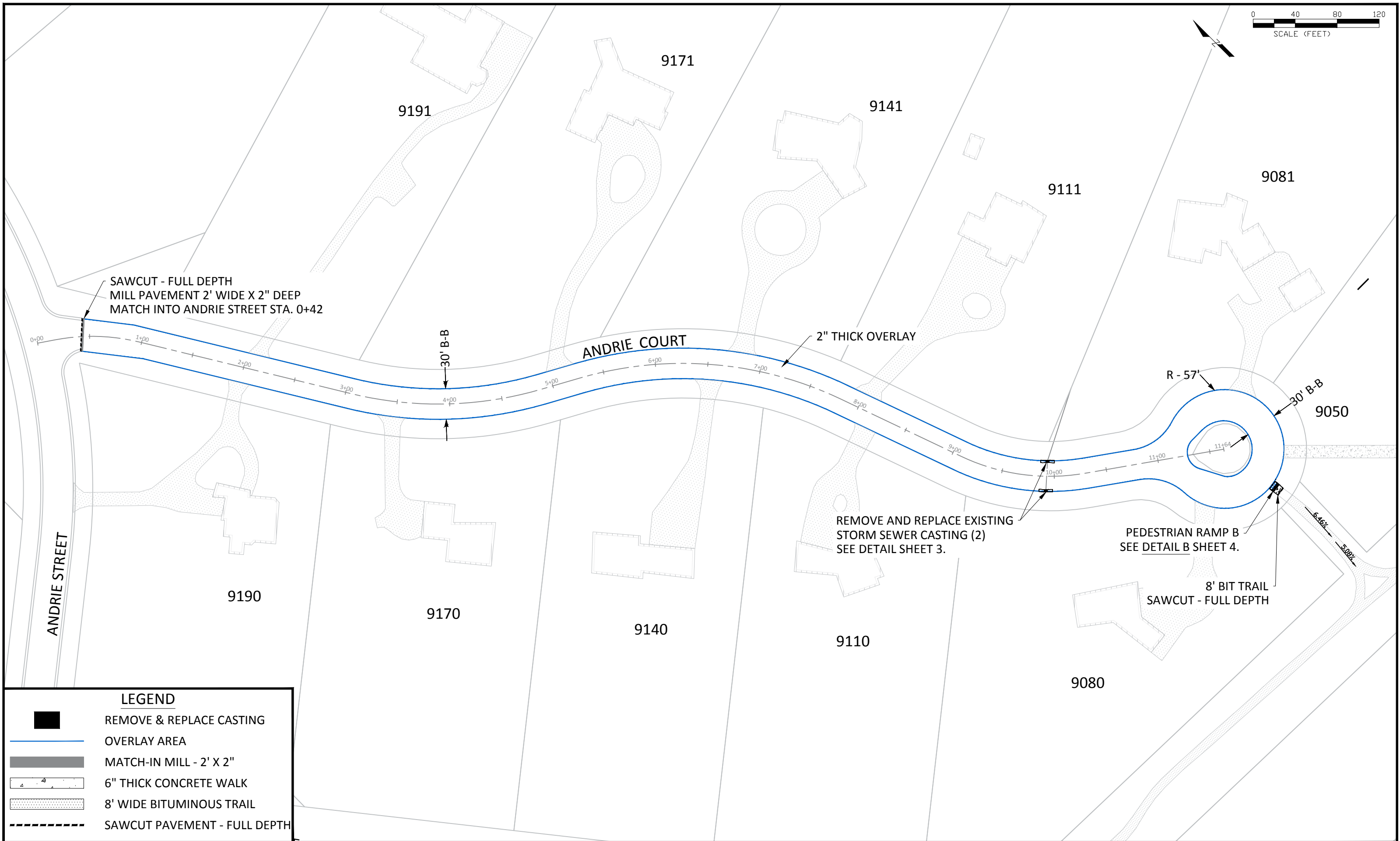

LEGEND	
	REMOVE & REPLACE CASTING
	OVERLAY AREA
	MATCH-IN MILL - 2' X 2"
	6" THICK CONCRETE WALK
	8' WIDE BITUMINOUS TRAIL
	SAWCUT PAVEMENT - FULL DEPTH

DATE	REVISION

I hereby certify that this plan, specification, or report was prepared by me or under my direct supervision and that I am a duly Licensed Professional Engineer under the laws of the State of Minnesota

*Bruce Westby*  
Bruce Westby  
Date: 4/3/18 Lic. No. 40116

DESIGNED BY: JJF  
DRAWN BY: JJF  
CHECKED BY: BRW  
DATE: 4/3/18  
FILE No. 18-03

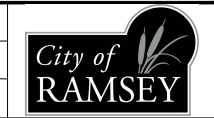

CITY OF RAMSEY  
7550 SUNWOOD DRIVE  
RAMSEY, MN 55303  
(763) 427-1410 FAX (763) 433-9898

NORTHFORK ITASCA SHORES OVERLAY

2018 STREET OVERLAY IMPROVEMENTS  
CITY PROJECT NO. 18-03  
CITY OF RAMSEY, MINNESOTA

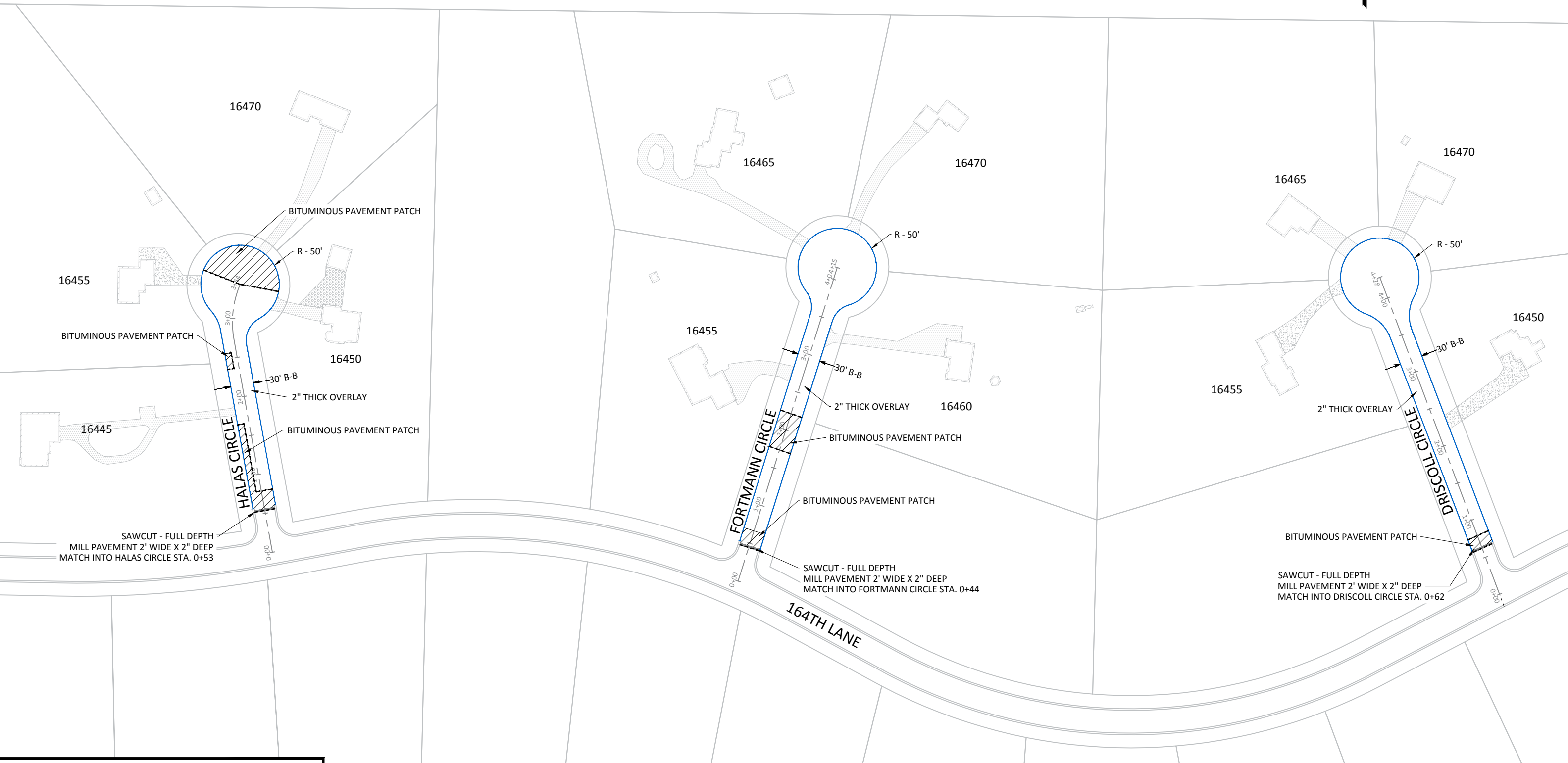

LEGEND	
	OVERLAY AREA
	MATCH-IN MILL - 2' X 2"
	BIT PAVEMENT PATCH
	SAWCUT PAVEMENT - FULL DEPTH

NOTE: BITUMINOUS PAVEMENT PATCH INCLUDES REMOVAL OF BITUMINOUS PAVEMENT, BITUMINOUS CURB AND AGGREGATE BASE AS NECESSARY. INCLUDES PLACING AGGREGATE BASE, BITUMINOUS PAVEMENT AND BITUMINOUS CURB AS NECESSARY EXISTING AGGREGATE BASE AND BITUMINOUS PAVEMENT GRADES.

DATE	REVISION

I hereby certify that this plan, specification, or report was prepared by me or under my direct supervision and that I am a duly Licensed Professional Engineer under the laws of the State of Minnesota

*Bruce Westby*  
Bruce Westby  
Date: 4/3/18 Lic. No. 40116

DESIGNED BY: JJF	DATE: 4/3/18
DRAWN BY: JJF	FILE No. 18-03
CHECKED BY: BRW	

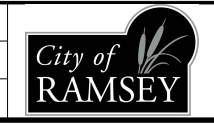



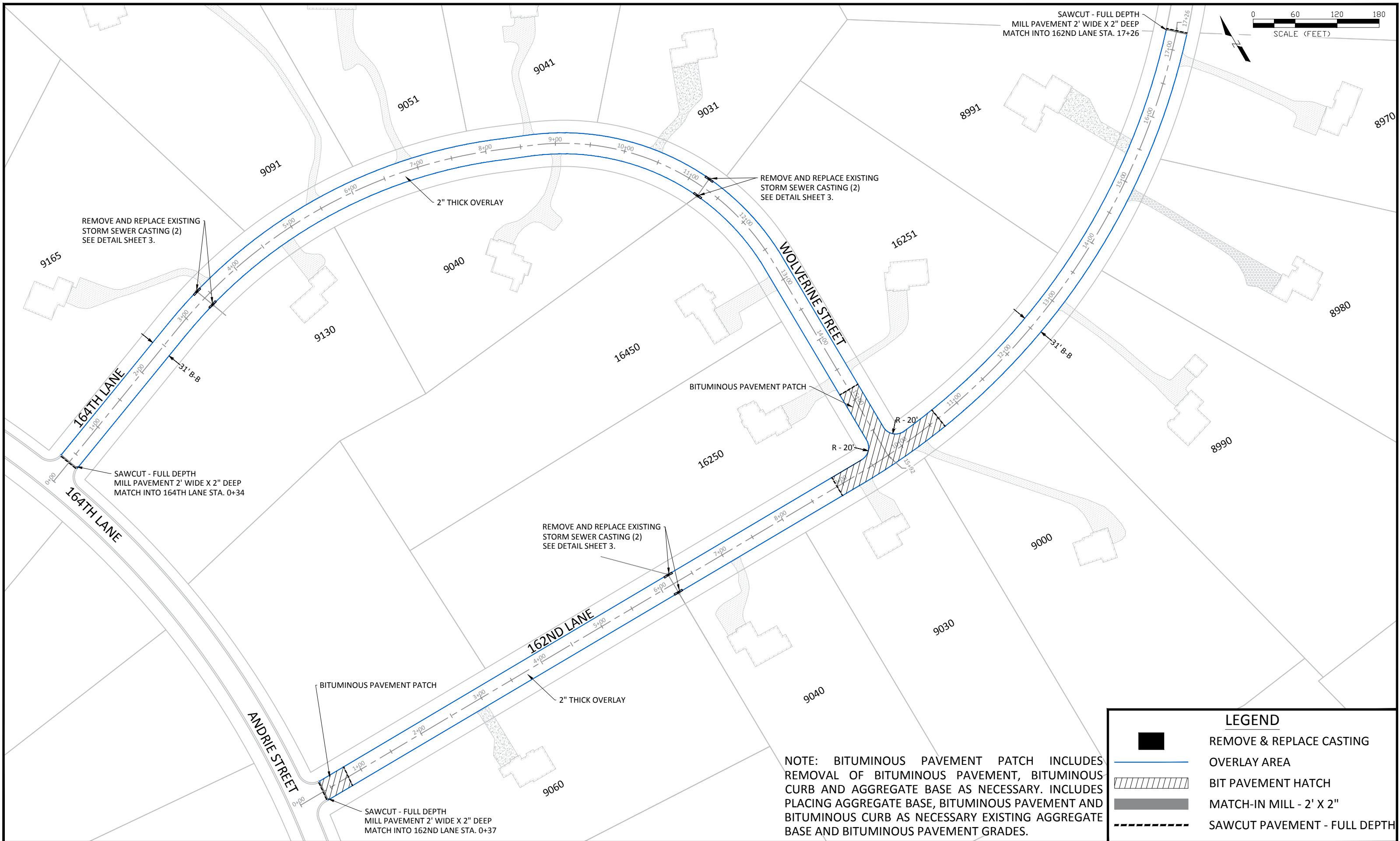

CITY OF RAMSEY  
7550 SUNWOOD DRIVE  
RAMSEY, MN 55303  
(763) 427-1410 FAX (763) 433-9898

NORTHFORK OVERLAY

2018 STREET OVERLAY IMPROVEMENTS  
CITY PROJECT NO. 18-03  
CITY OF RAMSEY, MINNESOTA

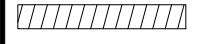

**LEGEND**

-  REMOVE & REPLACE CASTING
-  OVERLAY AREA
-  BIT PAVEMENT HATCH
-  MATCH-IN MILL - 2' X 2"
-  SAWCUT PAVEMENT - FULL DEPTH

NOTE: BITUMINOUS PAVEMENT PATCH INCLUDES REMOVAL OF BITUMINOUS PAVEMENT, BITUMINOUS CURB AND AGGREGATE BASE AS NECESSARY. INCLUDES PLACING AGGREGATE BASE, BITUMINOUS PAVEMENT AND BITUMINOUS CURB AS NECESSARY EXISTING AGGREGATE BASE AND BITUMINOUS PAVEMENT GRADES.

DATE	REVISION

I hereby certify that this plan, specification, or report was prepared by me or under my direct supervision and that I am a duly Licensed Professional Engineer under the laws of the State of Minnesota

*Bruce Westby*  
Bruce Westby  
Lic. No. 40116

DESIGNED BY: JJJ  
DRAWN BY: JJJ  
DATE: 4/3/18  
CHECKED BY: BRW  
FILE No. 18-03

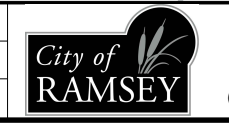



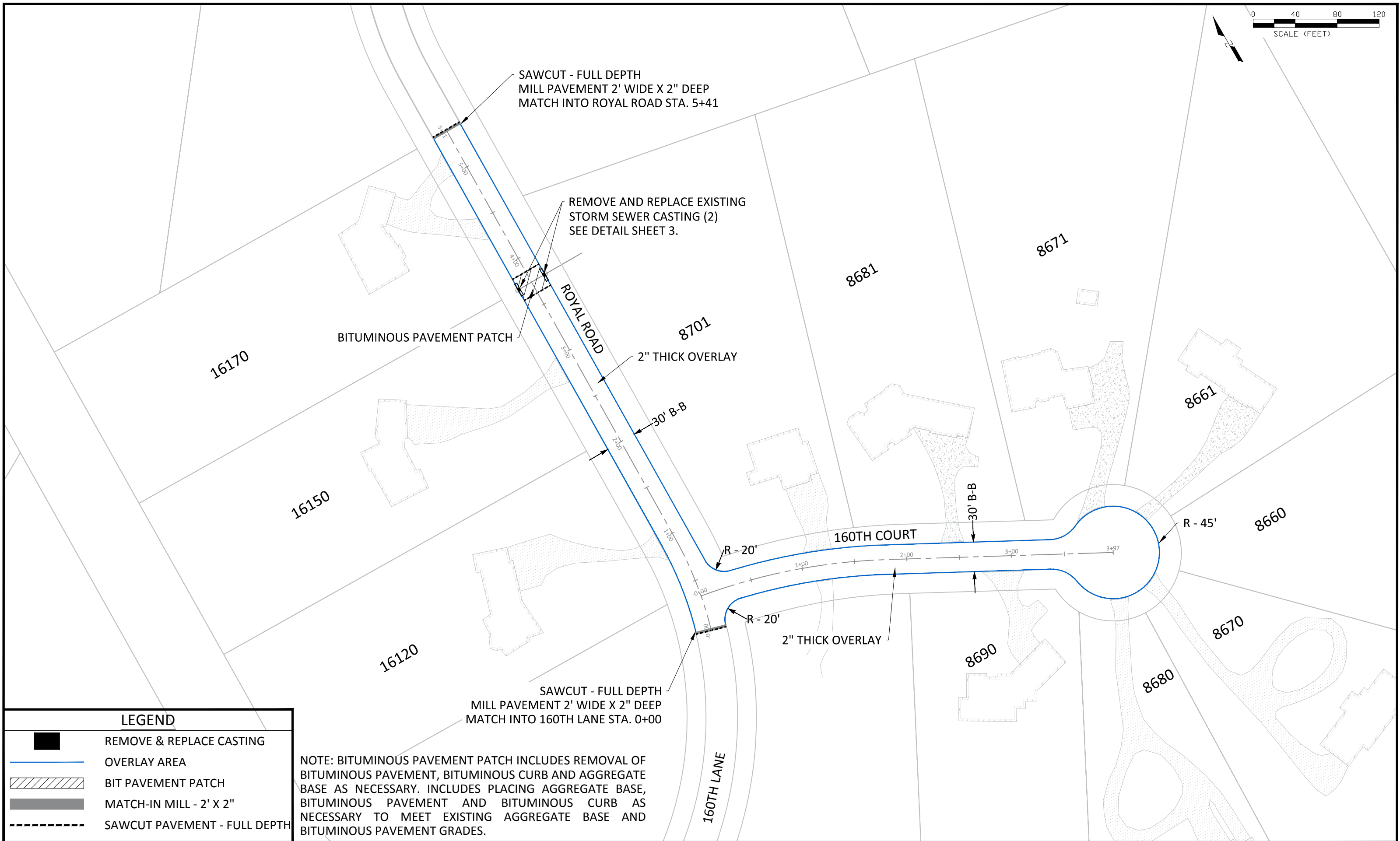

CITY OF RAMSEY  
7550 SUNWOOD DRIVE  
RAMSEY, MN 55303  
(763) 427-1410 FAX (763) 433-9898

NORTHFORK 2ND & 3RD OVERLAY

2018 STREET OVERLAY IMPROVEMENTS  
CITY PROJECT NO. 18-03  
CITY OF RAMSEY, MINNESOTA

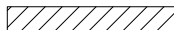

**LEGEND**

-  REMOVE & REPLACE CASTING
-  OVERLAY AREA
-  BIT PAVEMENT PATCH
-  MATCH-IN MILL - 2' X 2"
-  SAWCUT PAVEMENT - FULL DEPTH

NOTE: BITUMINOUS PAVEMENT PATCH INCLUDES REMOVAL OF BITUMINOUS PAVEMENT, BITUMINOUS CURB AND AGGREGATE BASE AS NECESSARY. INCLUDES PLACING AGGREGATE BASE, BITUMINOUS PAVEMENT AND BITUMINOUS CURB AS NECESSARY TO MEET EXISTING AGGREGATE BASE AND BITUMINOUS PAVEMENT GRADES.

DATE	REVISION

I hereby certify that this plan, specification, or report was prepared by me or under my direct supervision and that I am a duly Licensed Professional Engineer under the laws of the State of Minnesota.

*Bruce Westby*  
Bruce Westby  
Lic. No. 40116

DESIGNED BY: JJF  
DRAWN BY: JJF  
CHECKED BY: BRW  
DATE: 4/3/18  
FILE No. 18-03

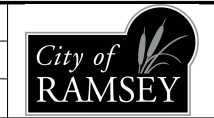

CITY OF RAMSEY  
7550 SUNWOOD DRIVE  
RAMSEY, MN 55303  
(763) 427-1410 FAX (763) 433-9898

NORTHFORK OAKS OVERLAY

2018 STREET OVERLAY IMPROVEMENTS  
CITY PROJECT NO. 18-03  
CITY OF RAMSEY, MINNESOTA