

City of Ramsey
Agenda
City Council Work Session
Monday, February 12, 2018
5:30 pm
Lake Itasca Room, 7550 Sunwood Drive NW

- 1. Call to Order**
- 2. Topics for Discussion**
 1. Discuss Strategic Direction for Community Sign and Streetscape Plan
 2. Policy for Televising Board and Commission Meetings and Attendance from Remote Location
 3. Discussion Regarding Proposed Updates to the Personnel Policy
 4. Pricing Strategy (portions of this case may be closed to the public)
- 3. Topics for Future Discussion**
 1. Review and Prioritize Future Topics/Calendar
- 4. Mayor/Council/Staff Input**
- 5. Adjournment**

Meeting Date: 02/12/2018

Information

Title:

Discuss Strategic Direction for Community Sign and Streetscape Plan

Purpose/Background:

Purpose

The purpose of this case is to discuss strategic direction for a work plan to complete a Community Sign and Streetscape Plan. This topic is intentionally abstract in order to provide initial direction and scoping.

The primary reason for bringing this topic forward at this point is to discuss replacing a destroyed sign at Bunker Lake Boulevard and Saint Francis Boulevard. It is possible to discuss replacement of this sign separate from the broader sign plan; however, Staff believes there is merit on reaching consensus on community sign design so that there can be a consistent appearance for these community signs across all districts and areas. Additionally, this topic is generally included within the Council's Strategic Plan, and is anticipated to be discussed in 2018. Finally, the City has been approached by The Links at Northfork to discuss rehabilitation of the shared sign at Highway 10 and Alpine Drive.

With additional resources in the Community Development Department and reconfirmation through the latest Strategic Plan Update, Staff feels confident that it has sufficient resources to complete this task in 2018. Projects within the Resilient Communities Project (RCP - University of Minnesota) have helped advance this discussion. Recent discussions on Highway 10 planning and other corridor planning efforts within the Comprehensive Plan have also helped advance this discussion and set it up for completion in 2018.

Requested Direction

Policy and Process Questions (focus of tonight's discussion; other policy questions will be asked and answered as part of the process itself)

- Do we want to focus on just consistent sign design, or do we want to include landscape and streetscape design?
- Do we want to utilize the existing sign package for The COR as a framework (see attached), or should part of the Work Plan include an exercise to review other sign design concepts? In other words, do we want to use the designs of the signs in The COR as a baseline, and then expand their use community wide by re-branding them for the City or other specific nodes (change colors and logos; see attached example)?
- Do we simply want to replace the sign at Bunker Lake Boulevard and Saint Francis Boulevard with its original design?
- Do we want to consider rehabbing The COR signs to match the City logo and colors (see attached) with The COR as a secondary logo on these signs? Estimated cost for this rehab is \$5,000 to \$10,000, depending on complexity (replacing panels would be the largest cost).

Potential Key Components of a Plan

- Define the goal of the plan. What are the key issues?
- Conceptual Sign Designs
- Map of Community Sign Locations
- Conceptual Standard Streetscape Design/Layout
 - Landscape Plan

- Sign Location
- Street Light Plan
- Street Light Banner Concept Design
- Conceptual Design/Layout at Key Nodes and Gateways
 - Eastern Gateway (Highway 10 border with Anoka)
 - Western Gateway (Highway 10 border with Elk River)
 - Bunker Lake Boulevard/TH 47 Node
 - 167th Avenue/TH 47 Node

Reasons for a Plan

- Consistent community branding and identity in corridors, districts, and nodes.
- Improved visibility and wayfinding for key nodes.

Background on Case

The following information is provided to help inform policy decisions.

Key Factors Influencing Priority of Plan

- Replace destroyed sign at Bunker Lake Boulevard (County Road 116) and Saint Francis Boulevard (MN Trunk Highway 47).
- Need for wayfinding signage, especially in The COR (identified as a need by The COR Market Panel, Resilient Communities Partnership (University of Minnesota), etc.)
- Staff previously brought forward a discussion topic on street light banner design. Generally speaking, it was the desire of the City Council to speak more strategically and comprehensively, rather than focus on a single, individual component. This discussion occurred in 2016, and the desire was to have this discussion wrapped up by now. Unfortunately, a combination of workload and available resources made it difficult to complete this task. Staff is confident that it now has the resources to accomplish this task and will make it a priority to complete.
- The existing large COR Sign near the Rail Station cost approximately \$50,000 and included a dynamic display. Other quotes showed this sign at \$75,000.
- The COR Sign at Ramsey Boulevard and Highway 10 was a rehab of the original Holiday Stationstore sign. The cost for sign was approximately \$6,500 with \$4,000 in landscape allowance.
- The Draw Park and Amphitheater Sign cost approximately \$20,000. In lieu of stone, a colored/painted sheet metal base was constructed. An actual stone base would have significantly increased the cost.
- The proposed pedestrian kiosk for The Draw Park and Amphitheater was estimated to cost approximately \$35,000, and included an actual stone base.
- To replace the sign at Bunker Lake Boulevard and Saint Francis Boulevard with a design to 'match' the existing COR Signs (with the City branding and color replaced) at an appropriate scale for that intersection would likely cost \$20,000 to \$40,000 depending on the final design and inclusion of a dynamic display.
- Within the last few years, the City of Andover built a new community sign at Bunker Lake Boulevard and Crosstown Boulevard. The cost of this sign was approximately \$20,000. With this in mind, Staff recommends that the City reevaluate the existing sign package to develop an updated concept design that is more cost effective (but still high quality).
- A key contributor to the higher cost of signs based on The COR Sign Package is the utilization of a significant amount of stone blocks.

Staff Recommendation

- Authorize \$7,500 for professional design services for streetscape design. This is a standard template that can be replicated throughout the community for key nodes.
- Bring ideas for new sign design options to the March 13 City Council Work Session.
- Intend to finish the planning document by July 1, 2018.
- Intend to begin construction of replacement sign at Bunker Lake Boulevard/Saint Francis Boulevard by October 1, 2018.

Timeframe:

30 Minutes.

Funding Source:

A majority of this project will be accomplished as part of normal Staff duties. Staff would request up to \$7,500 in professional services to aide with landscape architecture to provide high quality images to help supplement the plan. Staff believes this is a necessary step in order to make for a readable plan. This would come from an individual department professional services line item (already budgeted for in 2018).

The City did receive a settlement in the amount of \$7,500 from the party that destroyed the sign at Bunker Lake Boulevard and Saint Francis Boulevard that can be applied to the replacement of said sign itself.

Responsible Party(ies):

Community Development Director

Outcome:

Provide Staff direction on how to proceed with replacement of the destroyed sign at Bunker Lake Boulevard and Saint Francis Boulevard as well as direction on a broader Streetscape and Sign Plan.

Attachments

Example Sign Designs - The COR

Example Sign Design - COR Sign Rebranded as City

COR Parks Signage Quotes

City Council Work Session Minutes dated June 14, 2016

Design Services Proposal

June 14, 2016 Work Session Case

Form Review

Inbox	Reviewed By	Date
Patrick Brama	Patrick Brama	02/08/2018 09:10 AM
Tim Gladhill (Originator)	Tim Gladhill	02/08/2018 09:23 AM
Chris Anderson	Tim Gladhill	02/08/2018 12:00 PM
Tim Gladhill (Originator)	Tim Gladhill	02/08/2018 12:06 PM
Patrick Brama	JoAnn Shaw	02/08/2018 12:08 PM
Chris Anderson	JoAnn Shaw	02/08/2018 12:09 PM
Kurt Ulrich	Kurt Ulrich	02/08/2018 03:27 PM
Form Started By: Tim Gladhill		Started On: 02/08/2018 07:31 AM
Final Approval Date: 02/08/2018		



EXHIBIT B.1



Eastbound

Westbound

EXHIBIT B.2

LANDFORM
From Site to Finish

DESIGN FRAMEWORK
The COR at Ramsey
PYLON/COMMUNITY SIGN 'B'
Commuter Rail & Highway 10





EXHIBIT B.3

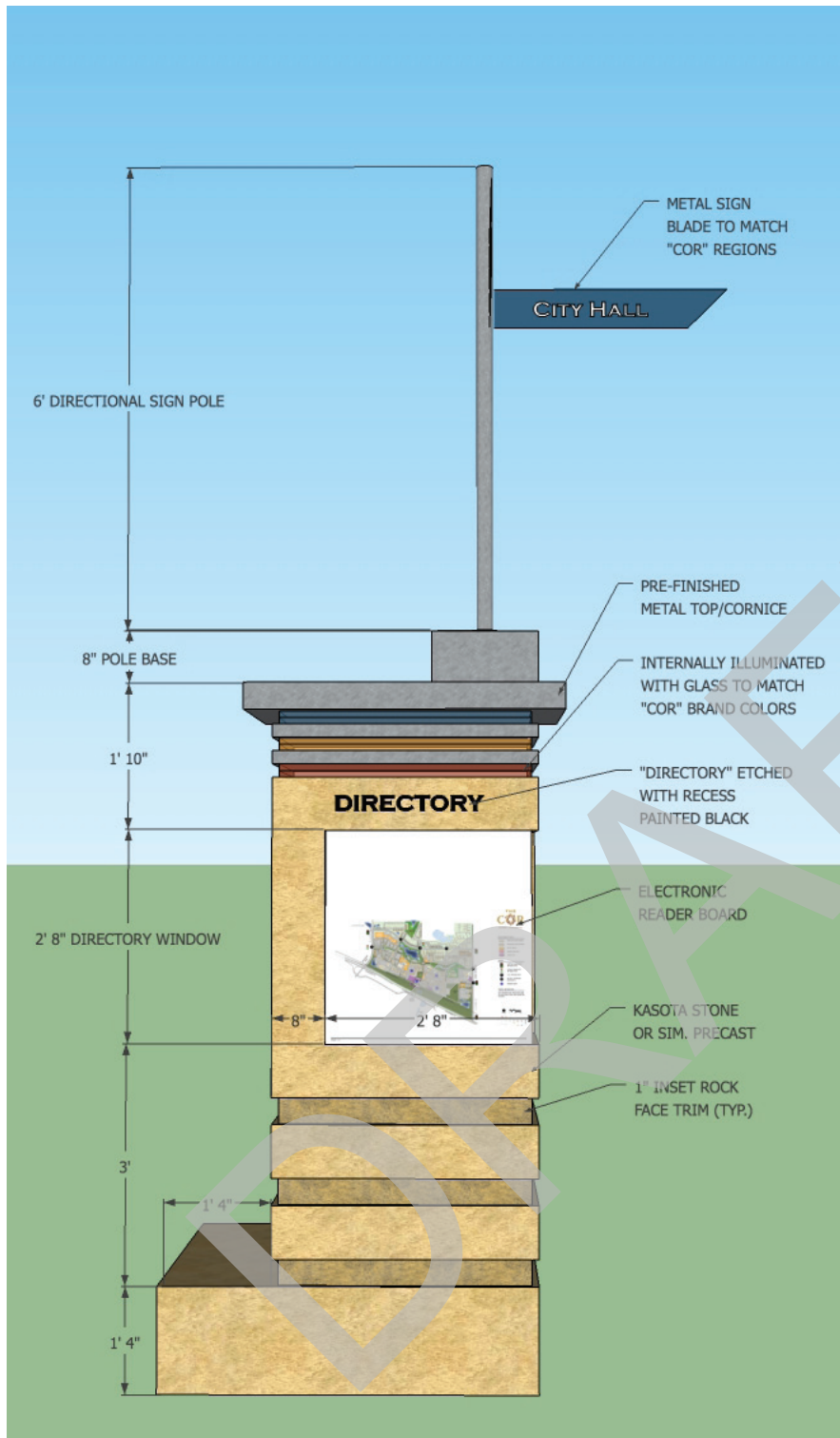

DIRECTORY PANEL VIEW



EVENTS PANEL VIEW

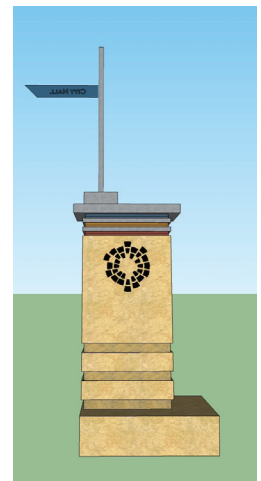

REAR VIEW

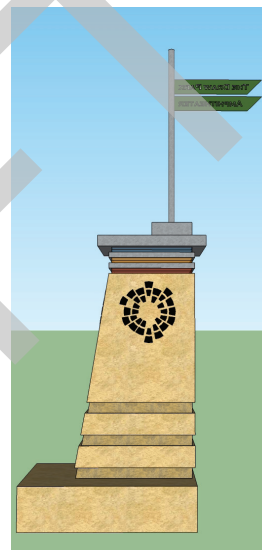

SIDE VIEW



PERSPECTIVE

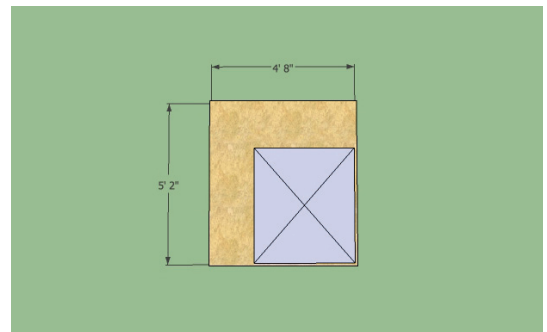

PLAN VIEW

EXHIBIT B.4

LANDFORM
From Site to Finish

DESIGN FRAMEWORK
The COR at Ramsey
COMMUNITY KIOSK 'A'
Commuter Rail & Veterans Dr.



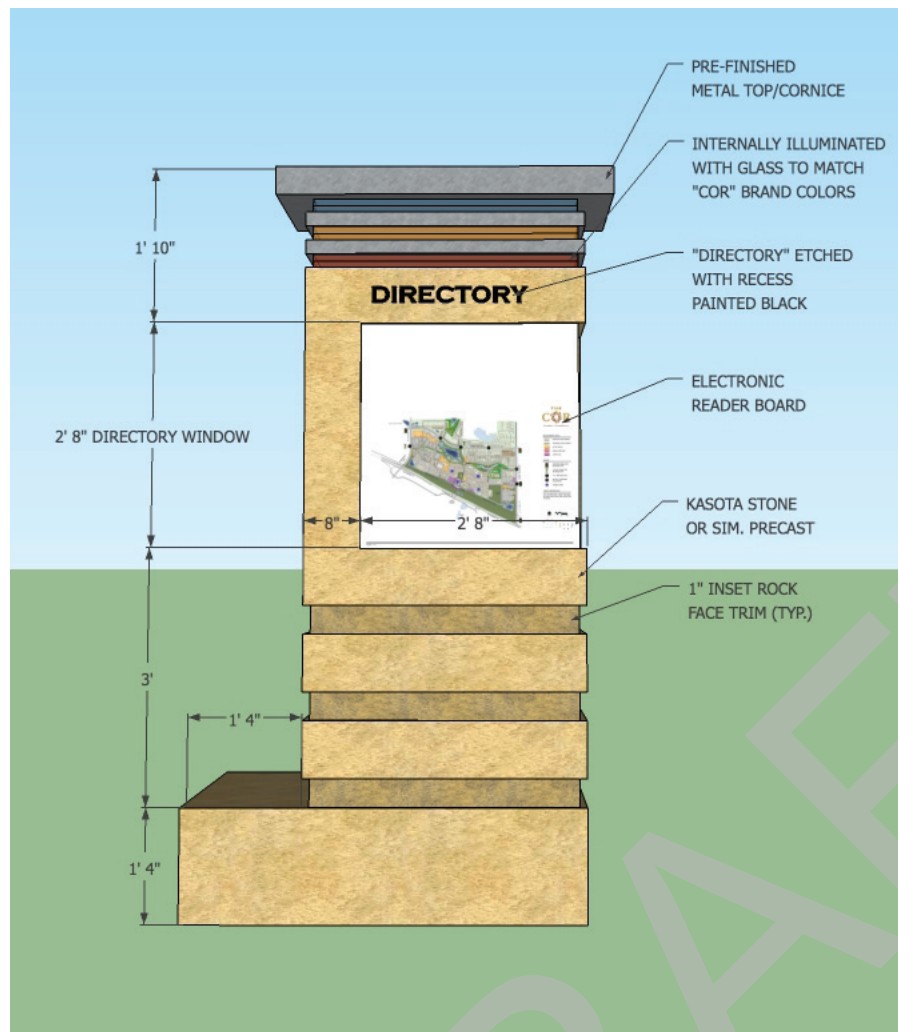

EVENTS PANEL VIEW

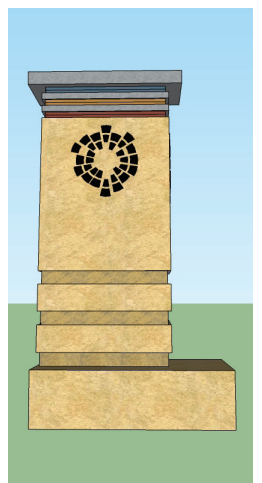

REAR VIEW

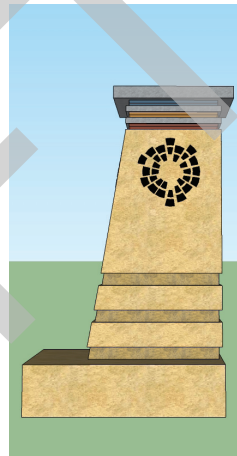

SIDE VIEW



PERSPECTIVE

DIRECTORY PANEL VIEW

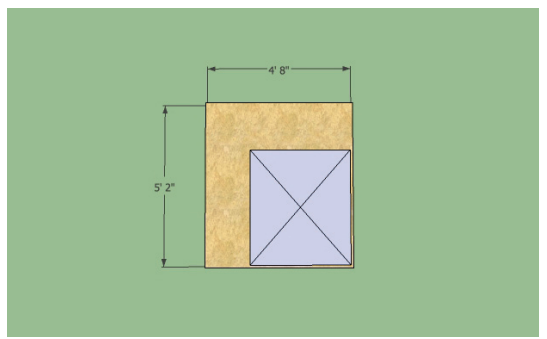

PLAN VIEW

EXHIBIT B.5

LANDFORM
From Site to Finish

DESIGN FRAMEWORK
The COR at Ramsey
COMMUNITY KIOSK 'B'
Sunwood Dr. & Center St.



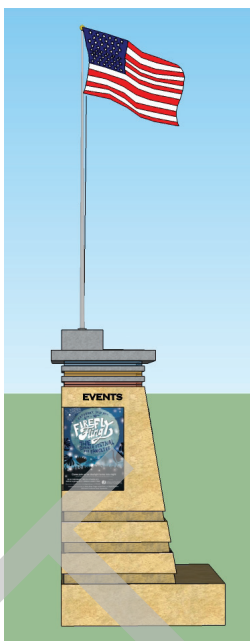
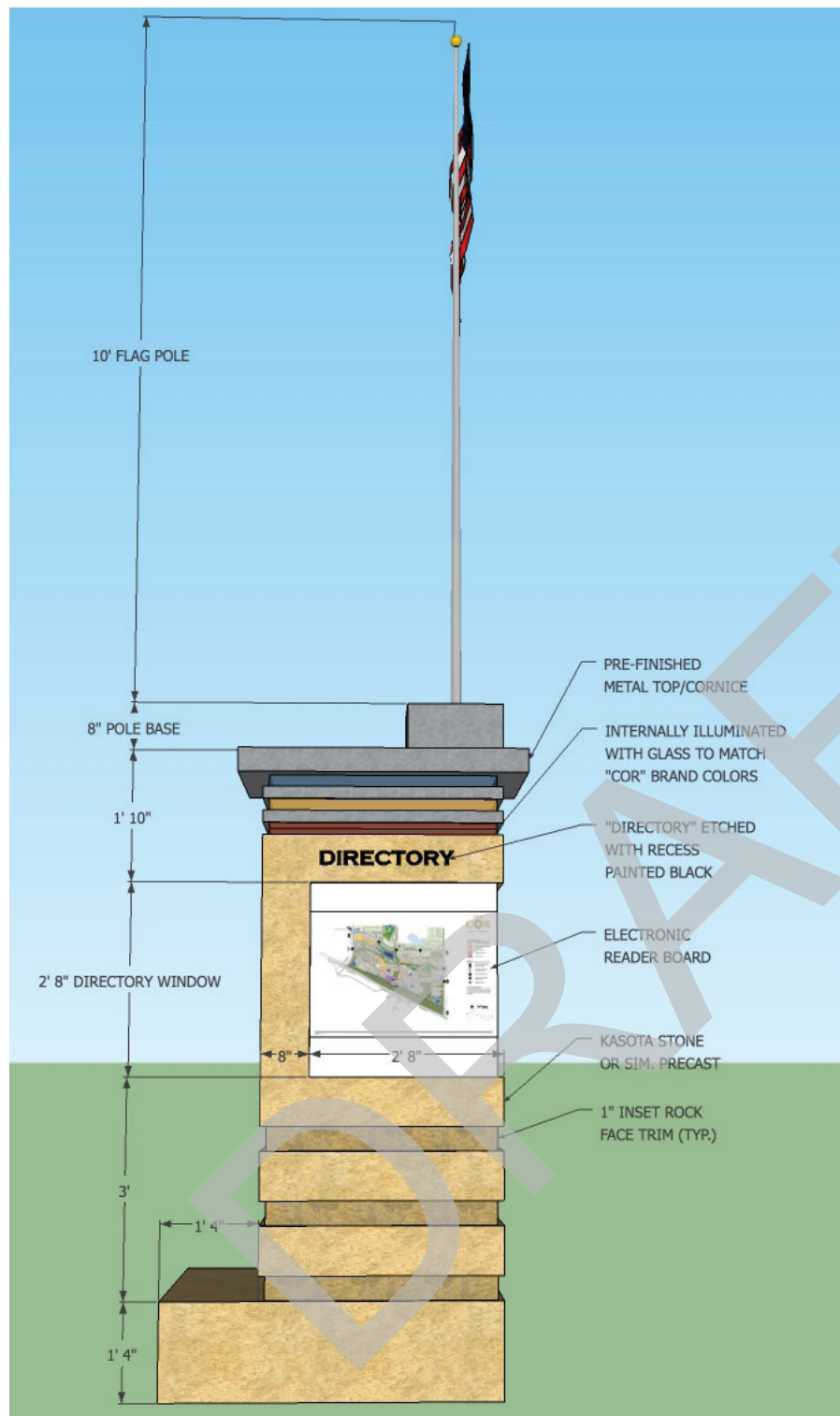

EVENTS PANEL VIEW

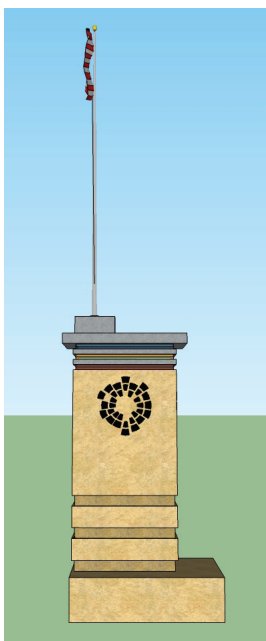

REAR VIEW

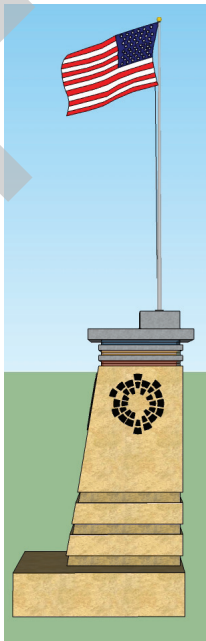

SIDE VIEW



PERSPECTIVE

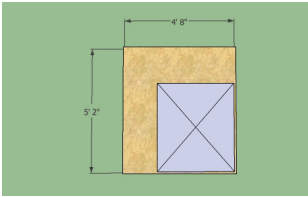

PLAN VIEW

DIRECTORY PANEL VIEW

EXHIBIT B.6



DESIGN FRAMEWORK
 The COR at Ramsey
 COMMUNITY KIOSK 'C'
 Sunwood Dr. at Municipal Plaza



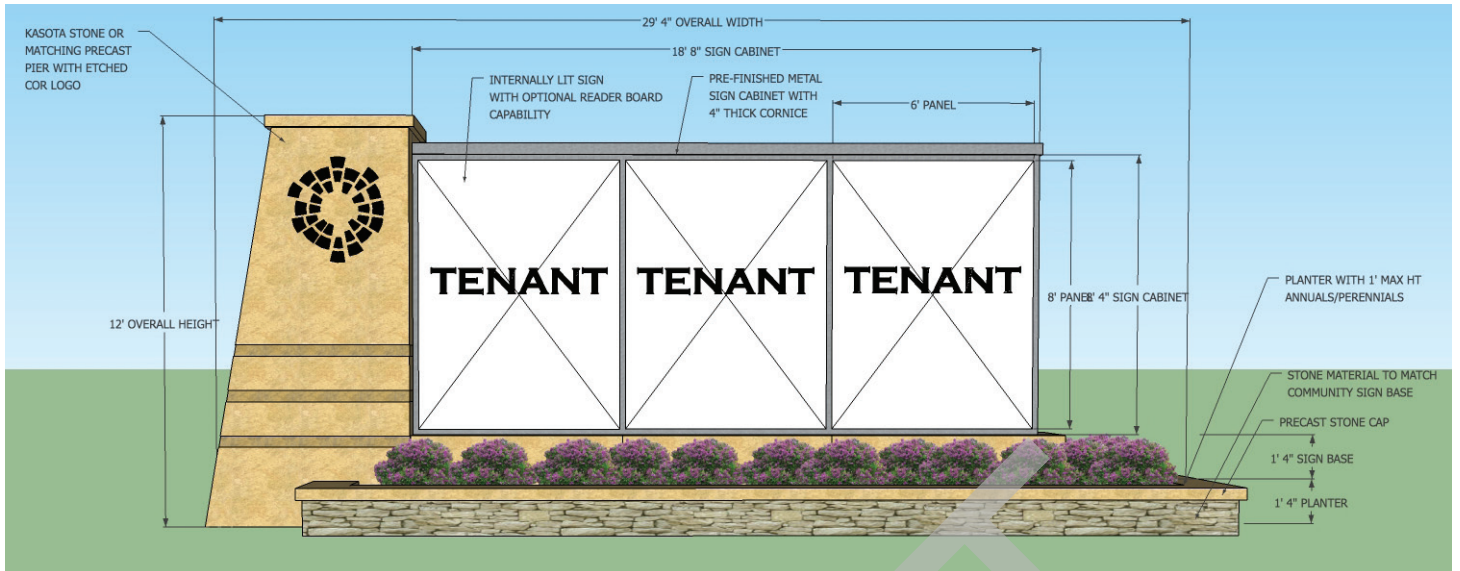

ELEVATION AT SUNWOOD

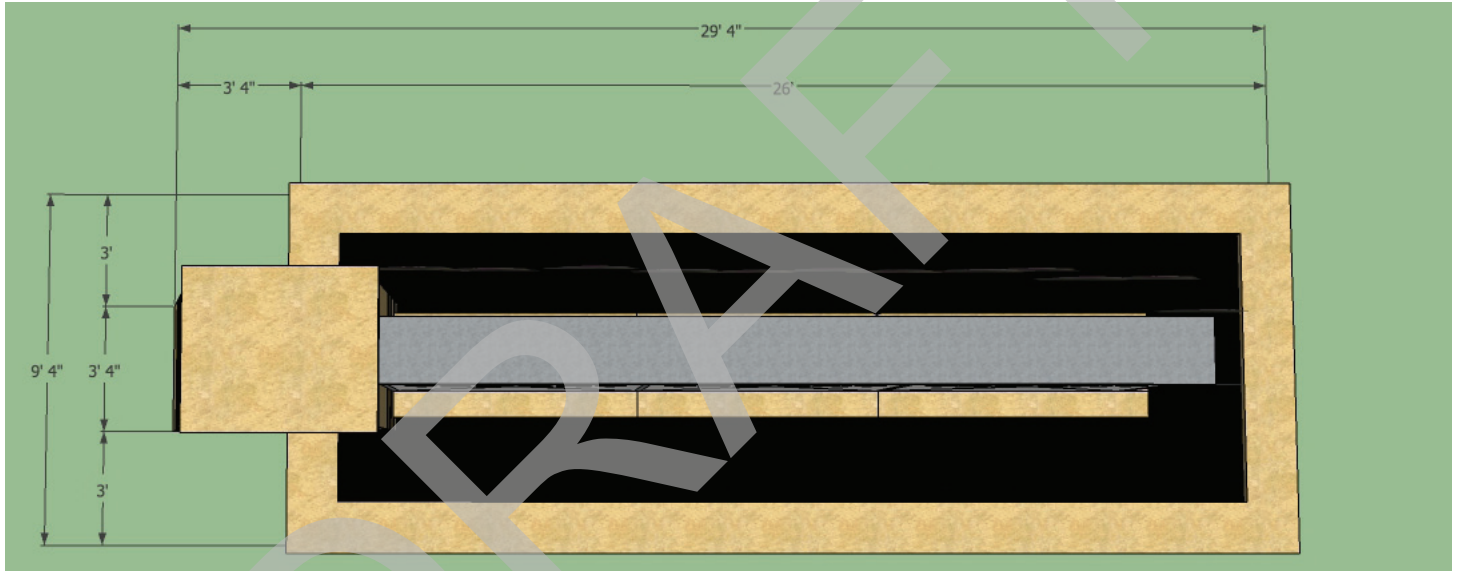

PLAN VIEW

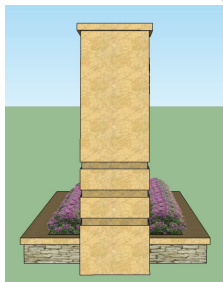

PROFILE VIEW

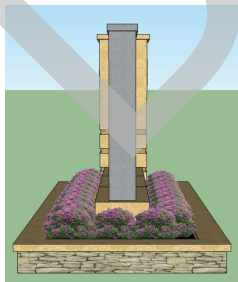

PROFILE VIEW

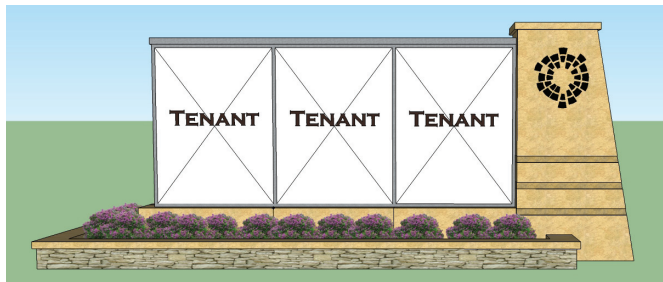

ELEVATION

EXHIBIT B.7



DESIGN FRAMEWORK
 The COR at Ramsey
 PROJECT GATEWAY SIGN 'A'
 Sunwood Dr. & Armstrong Blvd.



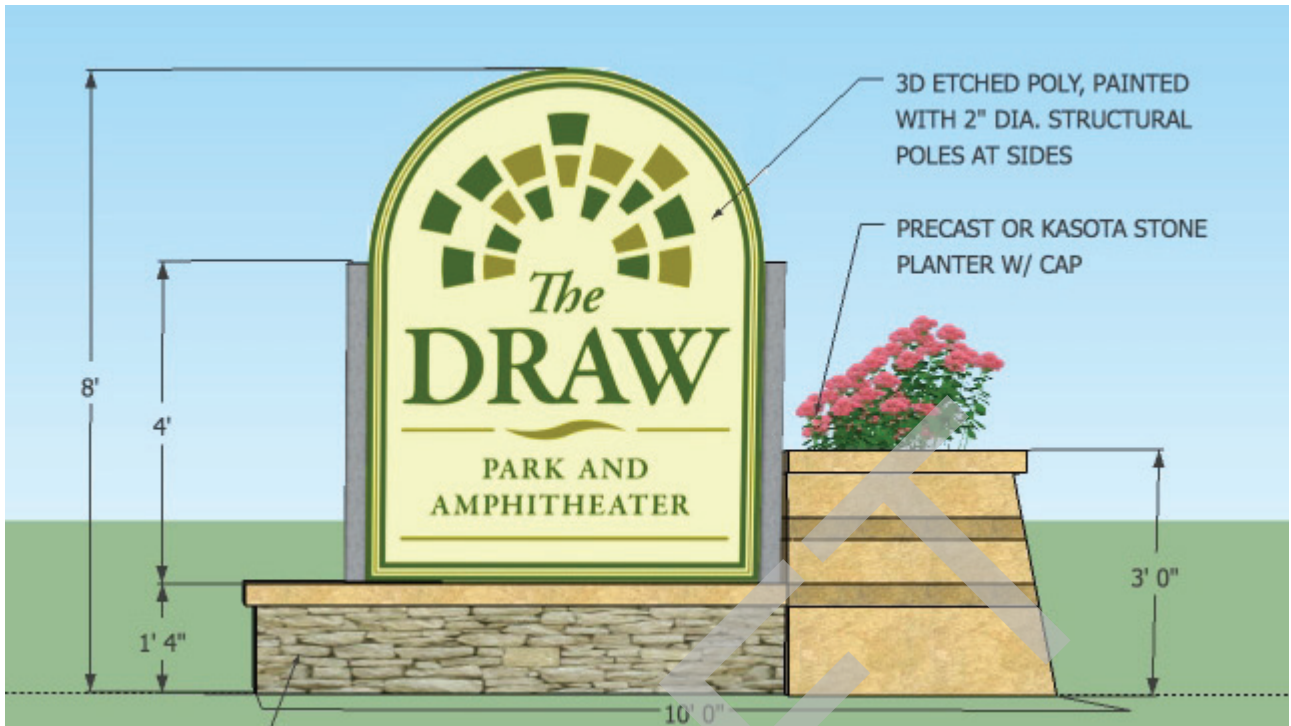
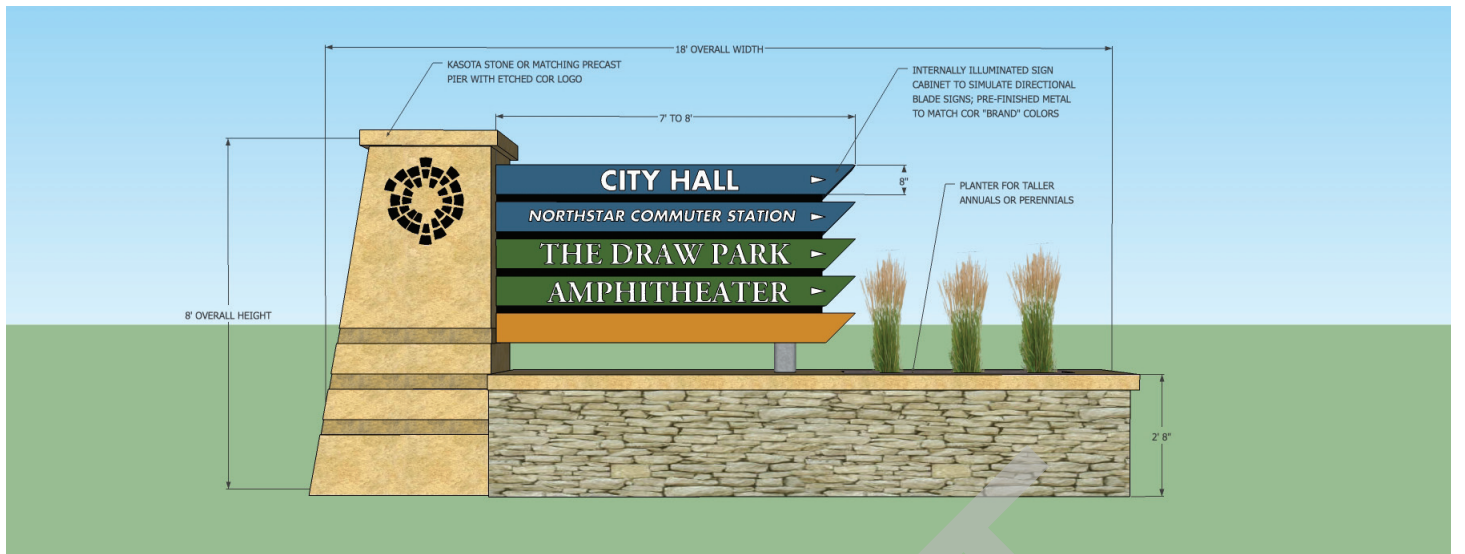

EXHIBIT B.8

LANDFORM
From Site to Finish

DESIGN FRAMEWORK
The COR at Ramsey
PUBLIC PARK SIGNS





ELEVATION AT EASTBOUND BUNKER LAKE

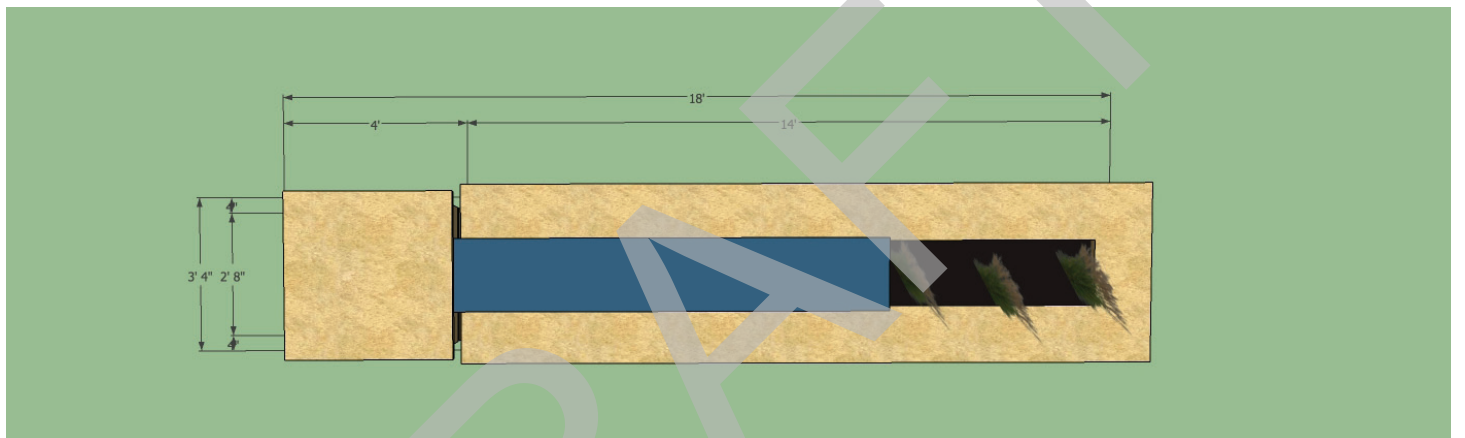

PLAN VIEW



PROFILE VIEW

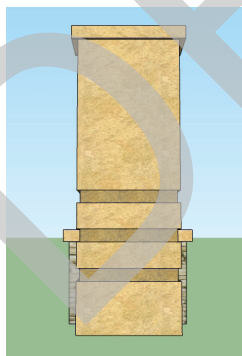

PROFILE VIEW



ELEVATION AT WESTBOUND BUNKER LAKE

EXHIBIT B.9

LANDFORM
From Site to Finish

DESIGN FRAMEWORK
The COR at Ramsey
PROJECT GATEWAY SIGN 'C'
Bunker Lake Blvd. & Center St.





ELEVATION AT SOUTH BOUND RAMSEY

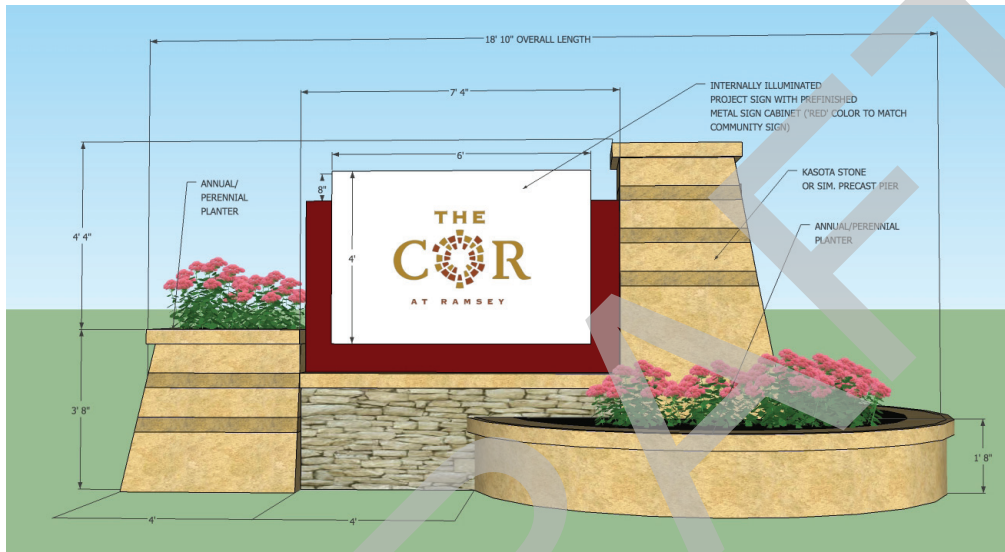

ELEVATION AT WESTBOUND BUNKER LAKE



PERSPECTIVE

EXHIBIT B.10

● ●
L A N D F O R M
 From Site to Finish

DESIGN FRAMEWORK
The COR at Ramsey
 PROJECT GATEWAY SIGN 'D'
 Bunker Lake Blvd. & Ramsey Blvd.



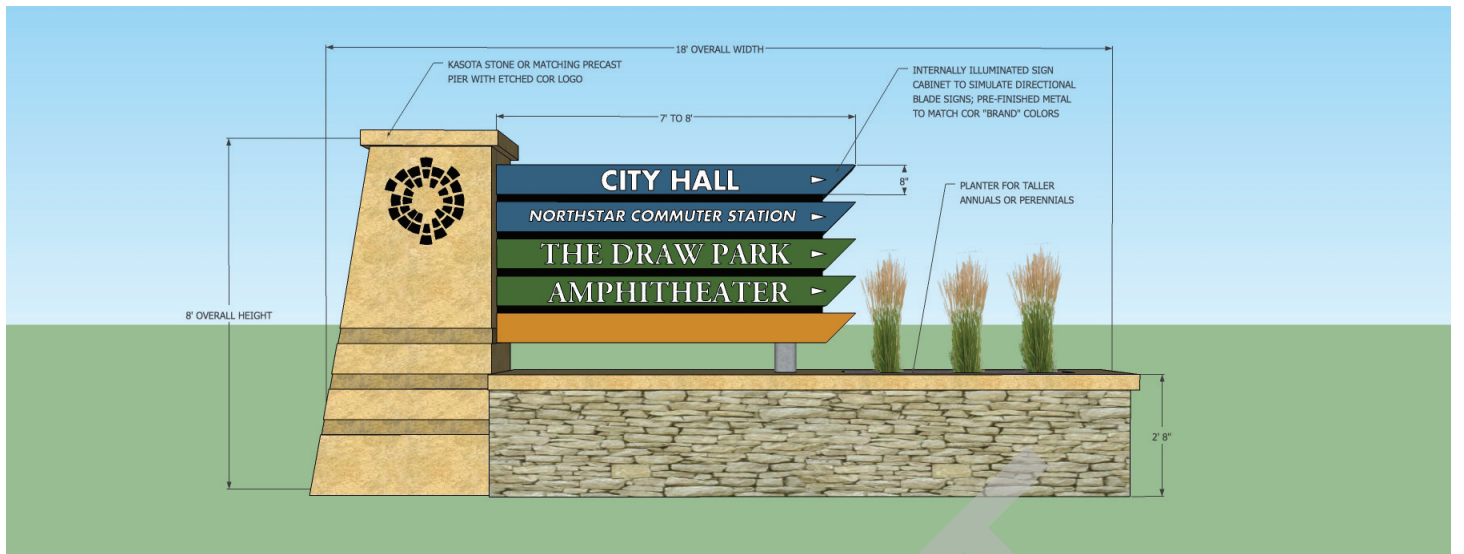

ELEVATION AT SOUTHBOUND RAMSEY

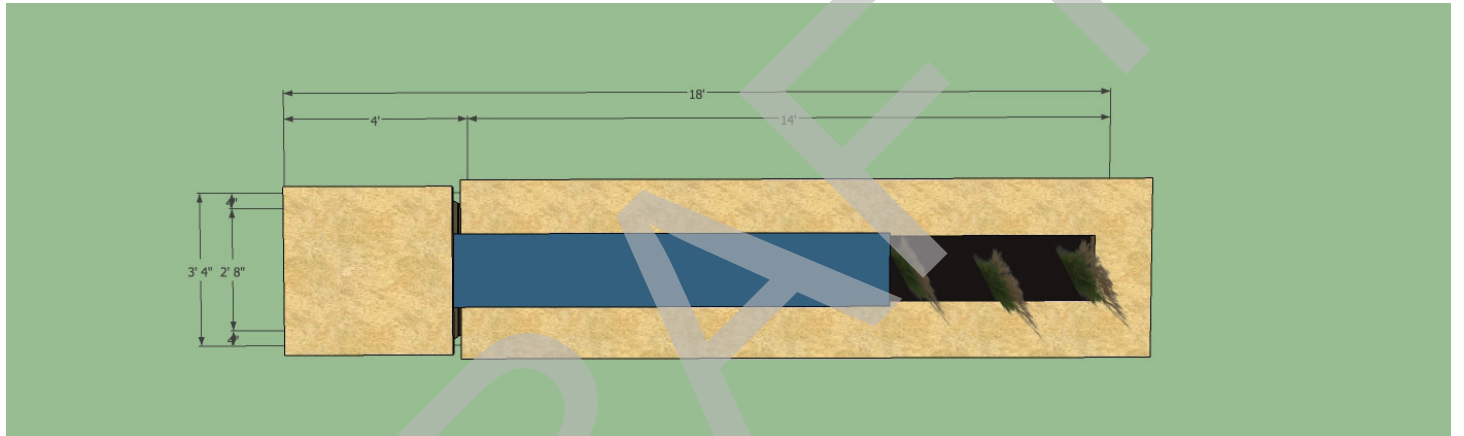

PLAN VIEW



PROFILE VIEW

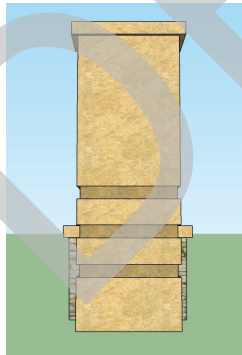

PROFILE VIEW



ELEVATION AT NORTHBOUND RAMSEY

EXHIBIT B.11



DESIGN FRAMEWORK
 The COR at Ramsey
 PROJECT GATEWAY SIGN 'E'
 Sunwood Dr. & Ramsey Blvd.





EXHIBIT B.12

●
●

L A N D F O R M

 From Site to Finish
 ●
●

DESIGN FRAMEWORK
 The COR at Ramsey
PUBLIC PARKING SIGNAGE
Standard Signage



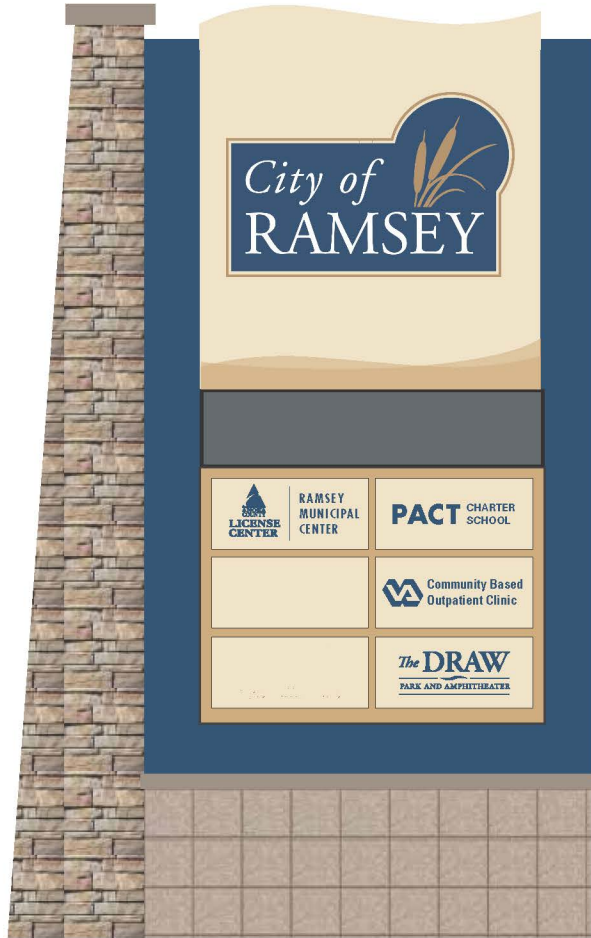

EXHIBIT B.13

LANDFORM
 From Site to Finish

DESIGN FRAMEWORK
The COR at Ramsey
LIGHT POLE BANNER SIGNS
Standard Signage

THE
COR
 RAMSEY, MINNESOTA



Eastbound



Westbound

EXHIBIT B.2

LANDFORM
From Site to Finish

DESIGN FRAMEWORK
The COR at Ramsey
PYLON/COMMUNITY SIGN 'B'
Commuter Rail & Highway 10





The Draw Entrance Monument(s)



Capital Improvement Program

2013 *thru* 2017

City of Ramsey, Minnesota

Department Park Improvements
Contact

Project # 12-PARK-003
Project Name The Draw Entrance Monument

Type Improvement
Useful Life 25
Category Park Improvement
Priority 6-Planned
Status Active

Total Project Cost: \$20,000

Description

Adding an entrance monument(s) to the recently constructed (2010) park.

Justification

This project will create entrance monument(s) at The Draw aiding park patrons in locating the farmers market, concerts, and soccer and ballfield games.

Expenditures	2013	2014	2015	2016	2017	Total
Improvements Other than Build	20,000					20,000
Total	20,000					20,000
Funding Sources	2013	2014	2015	2016	2017	Total
Park Improvement Trust Fund	20,000					20,000
Total	20,000					20,000



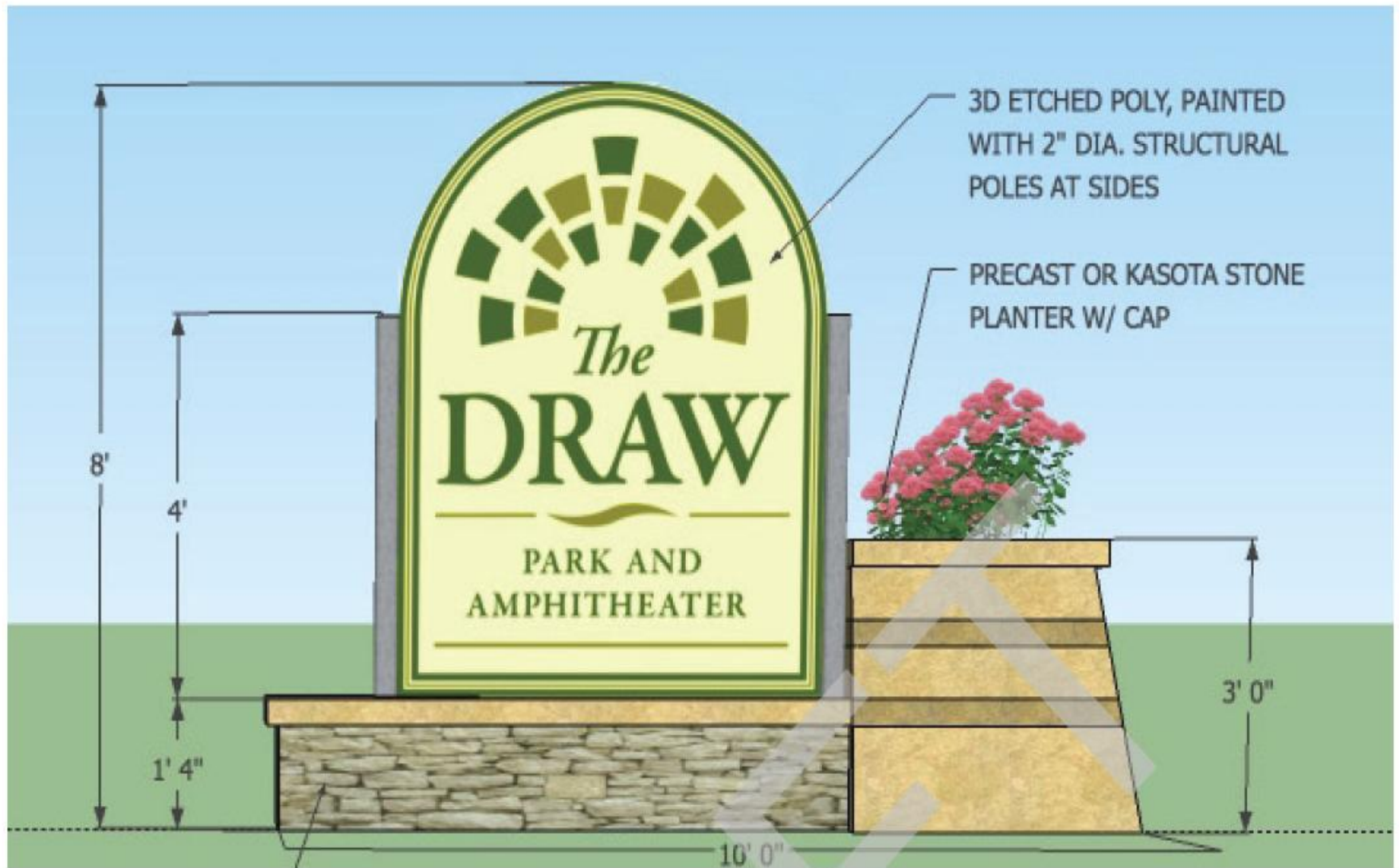







② Plan View

Scale: 1/2"=1'-0"

Monument - Basic Option

- Ⓐ Cabinet
FABRICATED ALUMINUM CABINET
PAINTED GREEN AND TAN
LOGO - DIMENSIONAL 1/4" ACRYLIC

Install
DIRECT EMBED

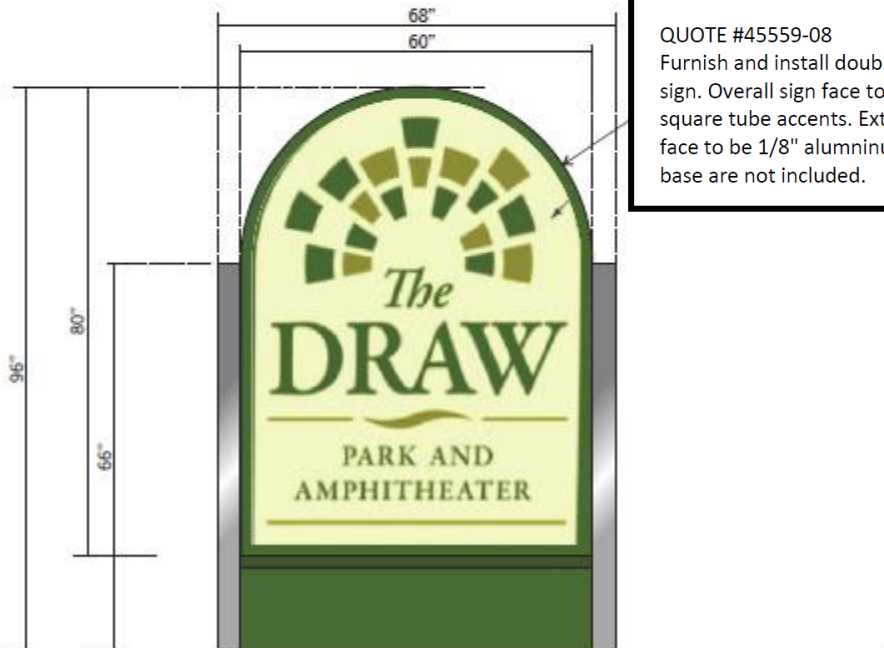

① Elevation

Scale: 1/2"=1'-0"

QUOTE #45559-08

\$12,100.00

Furnish and install double sided exterior monument "The Draw" (exhibit B.8) sign. Overall sign face to be 48"x80" with 16" pole cover base. Sides have 4" square tube accents. Externally illuminated with flood lamps by others. Sign face to be 1/8" aluminum with digitally printed graphics. Sign base and stone base are not included.

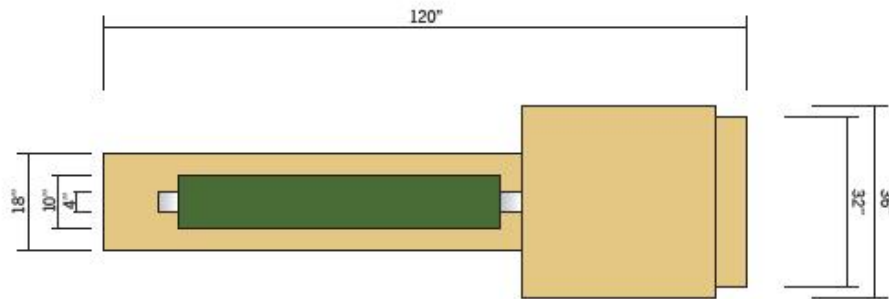

② Plan View

Scale: 1/2"=1'-0"

Monument - Faux Paint Option

- Ⓐ **Cabinet**
FABRICATED ALUMINUM CABINET
PAINTED GREEN AND TAN
LOGO - DIMENSIONAL 1/4" ACRYLIC
- Ⓑ **Aluminum Base**
FABRICATED ALUMINUM BASE W/ FABRICATED
REVEALS
BASE HAS FAUX PAINT FINISH TO SIMULATE STONE

Install
MOUNT CABINET AND BASE TO
POURED CONCRETE FOOTING

QUOTE #45559-06

\$19,750.00

Furnish and install double sided exterior monument "The Draw" (exhibit B.8) sign. Overall sign face to be 48"x80" Externally illuminated with flood lamps by others. Sign face to be 1/8" aluminum with digitally printed graphics. Sign base and planter to be fabricated aluminum with 2 color paint finish.

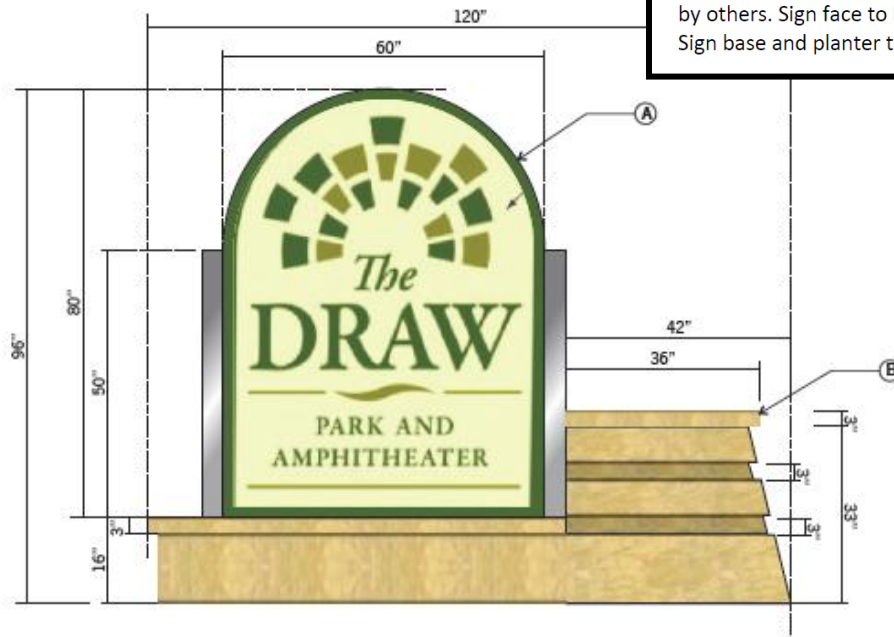

① Elevation

Scale: 1/2"=1'-0"

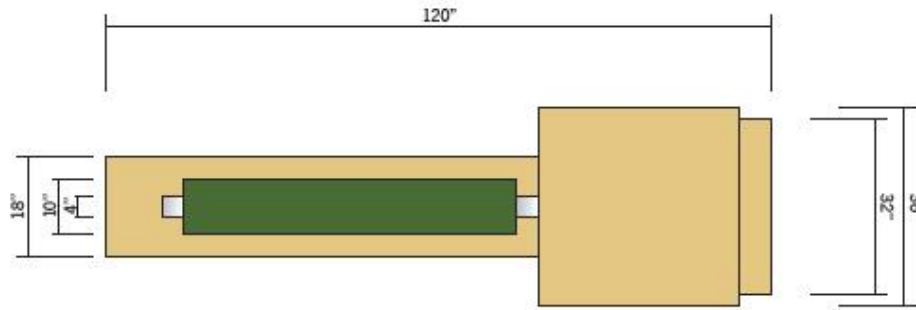

② Plan View

Scale: 1/2"=1'-0"

Monument - Stone Option

Ⓐ **Cabinet**
 FABRICATED ALUMINUM CABINET
 PAINTED GREEN AND TAN
 LOGO - DIMENSIONAL 1/4" ACRYLIC

Ⓑ **Stone Base**
 MINNESOTA DOLOMITE AND STONE VENEER

Install
 MOUNT CABINET TO POURED CONCRETE BASE

QUOTE #45559-04

\$32,800.00

Furnish and install double sided exterior monument "The Draw" (exhibit B.8) sign. Externally illuminated with flood lamps by others. Flat lexan with vinyl graphics.

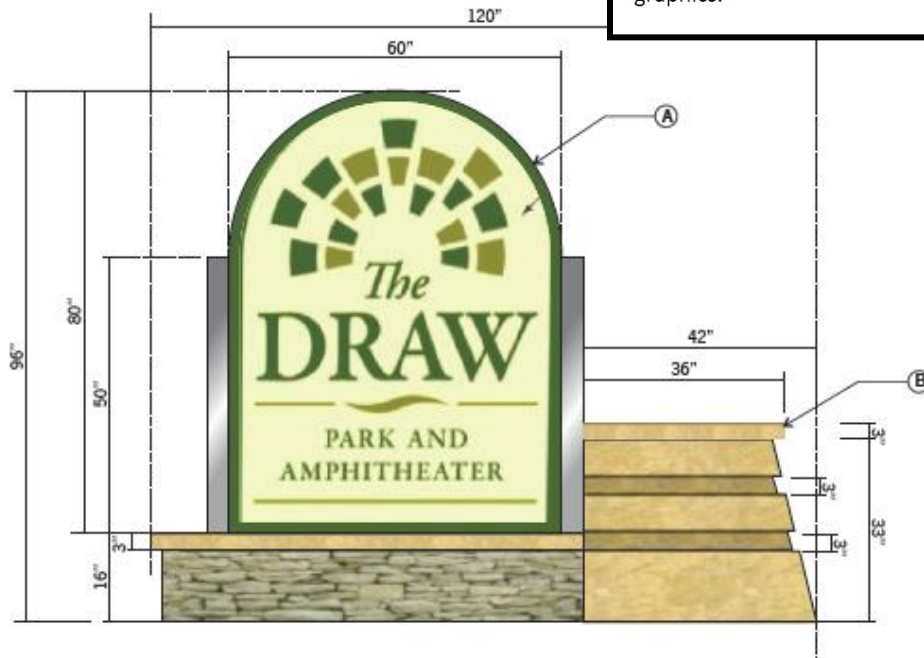

① Elevation

Scale: 1/2"=1'-0"



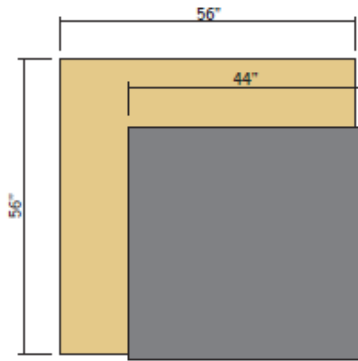

⑤ Plan View Scale: 1/2"-1'-0"

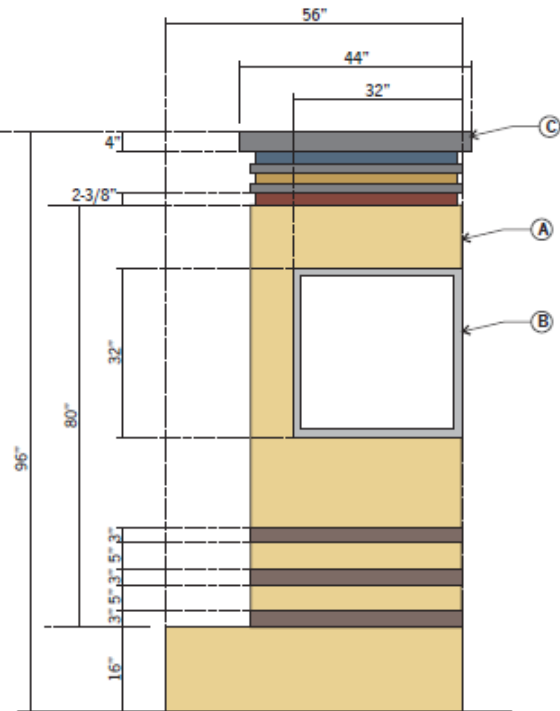

① Directory Panel Elevation Scale: 1/2"-1'-0"

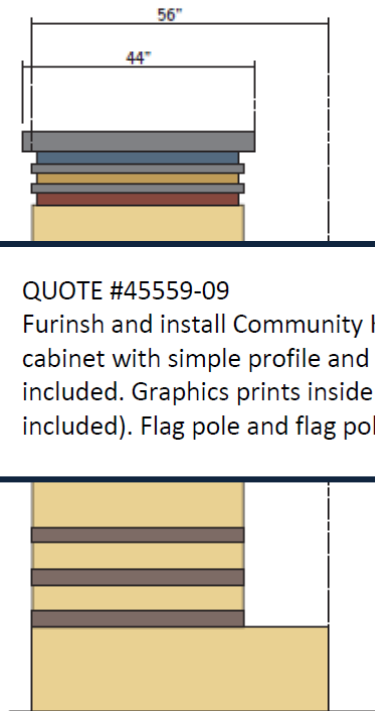

② Events Panel Elevation Scale: 1/2"-1'-0"

Community Kiosk - Basic Option

- Ⓐ Aluminum Kiosk
FABRICATED ALUMINUM DISPLAY
WITH PAINTED ACCENTS
- Ⓑ Directory Cabinet
FABRICATED ALUMINUM DISPLAY
DIGITALLY PRINTED GRAPHICS
NON-ILLUMINATED
- Ⓒ Cap
FABRICATED ALUMINUM
PAINTED COLOR BANDS
NO ILLUMINATION

Install
DIRECT EMBED

QUOTE #45559-09 \$10,700.00
 Furinsh and install Community Kiosk "C". Kiosk to be fabricated aluminum cabinet with simple profile and fabricated aluminum base. No-illuminated is included. Graphics prints inside lockable hinged cabinet (prints not included). Flag pole and flag pole and flag pole base by others.

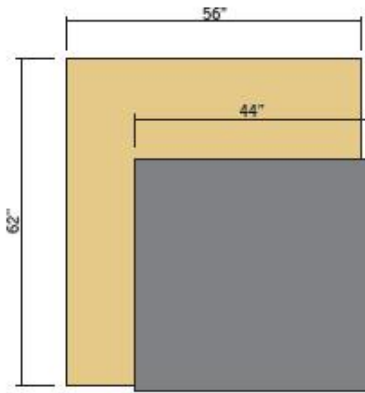

⑤ Plan View

Scale: 1/2"=1'-0"

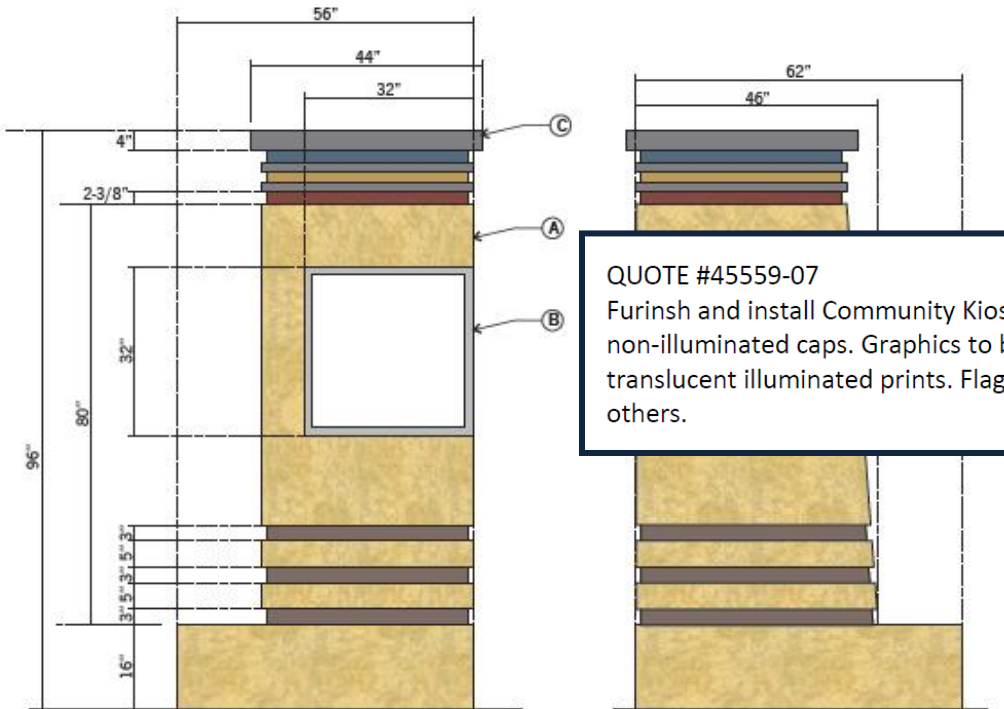

① Directory Panel Elevation

Scale: 1/2"=1'-0"

② Events Panel Elevation

Scale: 1/2"=1'-0"

Community Kiosk - Faux Paint Option

- Ⓐ **Aluminum Kiosk**
FABRICATED ALUMINUM DISPLAY
WITH FABRICATED REVEALS
FAUX PAINTED TO RESEMBLE STONE
 - Ⓑ **Directory Cabinet**
FABRICATED ALUMINUM DISPLAY
DIGITALLY PRINTED GRAPHICS
INTERNALLY ILLUMINATED WITH WHITE LED
 - Ⓒ **Illuminated Cap**
FABRICATED ALUMINUM
DIGITALLY PRINTED ACCENT COLOR BANDS
INTERNALLY ILLUMINATED WITH LED
PAINTED GREY
 - Ⓓ **Logo**
1/4" DIMENSIONAL LOGO PAINTED BLACK
- Install**
DIRECT EMBED

QUOTE #45559-07

Furish and install Community Kiosk "C". Kiosk to be fabricated aluminum, with non-illuminated caps. Graphics to be custom fabricated light boxes with static translucent illuminated prints. Flag pole and flag pole and flag pole base by others.

\$16,450.00

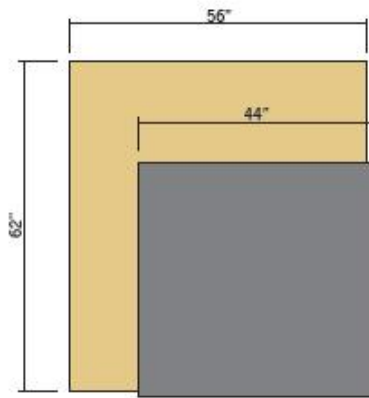

⑤ Plan View

Scale: 1/2"=1'-0"

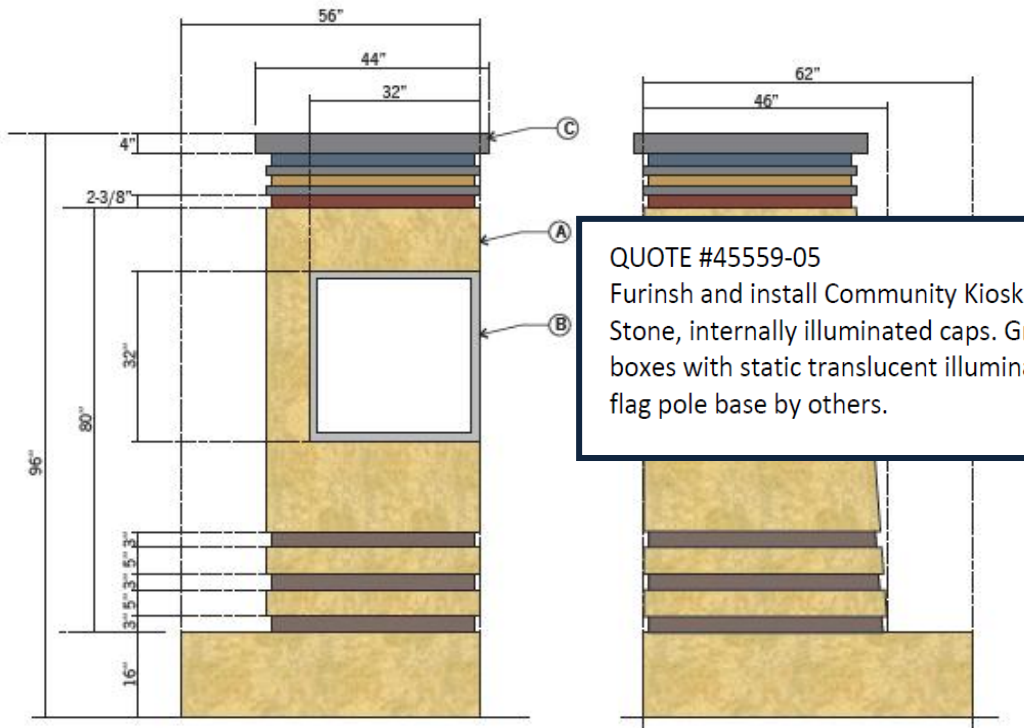

① Directory Panel Elevation

Scale: 1/2"=1'-0"

② Events Panel Elevation

Scale: 1/2"=1'-0"

Community Kiosk - Stone Option

- Ⓐ Stone Kiosk
MINNESOTA DOLOMITE AND STONE VENEER
INSET REVEALS AS SHOWN
- Ⓑ Directory Cabinet
FABRICATED ALUMINUM DISPLAY
DIGITALLY PRINTED GRAPHICS
INTERNALLY ILLUMINATED WITH WHITE LED
- Ⓒ Illuminated Cap
FABRICATED ALUMINUM
DIGITALLY PRINTED ACCENT COLOR BANDS
INTERNALLY ILLUMINATED WITH LED
PAINTED GREY
- Ⓓ Logo
CARVED/BLASTED PAINT FILLED LOGO

Install
ANCHOR CAP TO STONE BASE AS REQUIRED

QUOTE #45559-05 \$35,540.00
 Finish and install Community Kiosk "C". Kiosk to be constructed of Kasota Stone, internally illuminated caps. Graphics to be custom fabricated light boxes with static translucent illuminated prints. Flag pole and flag pole and flag pole base by others.



**CITY COUNCIL WORK SESSION
CITY OF RAMSEY
ANOKA COUNTY
STATE OF MINNESOTA**

The Ramsey City Council conducted a City Council Work Session on Tuesday, June 14, 2016, at the Ramsey Municipal Center, 7550 Sunwood Drive NW, Ramsey, Minnesota.

Members Present: Mayor Sarah Strommen
Councilmember Jill Johns
Councilmember Mark Kuzma
Councilmember John LeTourneau
Councilmember Chris Riley
Councilmember Melody Shryock
Councilmember Kristine Williams (arrived at 5:45 p.m.)

Also Present: City Administrator Kurtis Ulrich
Public Works Superintendent Grant Riemer
Human Resources Manager Colleen Lasher
Community Development Director Timothy Gladhill
Asst. City Administrator/Economic Development Manager Patrick Brama
Public Information and Events Specialist Nichole Wenberg

1. CALL TO ORDER

Mayor Strommen called the City Council Work Session to order at 5:35 p.m.

2. TOPICS FOR DISCUSSION

2.01: Policy for Recruitment, Application, and Interview Process of Appointing City Board and Commission Members

Human Resources Manager Lasher reviewed the staff report.

Mayor Strommen asked how a term would become out of alignment.

Human Resources Manager Lasher provided an example from the past that occurred with the Environmental Policy Board. She stated that ideally the City would prefer for between one to three terms to come to term at once and no more than that.

Mayor Strommen stated that if it was just the once situation she did not see a need for the additional language as the language could appear to state that the City frequently changes the terms to realign.

Human Resources Manager Lasher noted that the Charter Commission language has been removed in the draft policy as those appointments are made by the Chief District Judge. She noted that she hopes to bring this before the Council for formal adoption at the next meeting.

Councilmember Kuzma asked if the Council has any power to make a recommendation to the District Judge for the Charter Commission.

Human Resources Manager Lasher stated that it is her understanding that the Council could submit a letter to the judge supporting or not supporting a candidate.

Councilmember Riley stated that he agrees that the changes work well and was in favor of not making incumbents go through the entire process to reapply.

Councilmember LeTourneau asked if there is any desire for the Council to conduct an interview process of the Charter Commission candidates as a first step before the appointments are made.

Mayor Strommen stated that the Council would not be a part of the formal process but could do that as a side step, noting that all candidates would still be able to apply to the judge.

Human Resources Manager Lasher noted that if that is desired, the interviews would be done on a different time frame as those appointments are made on a calendar year cycle.

Councilmember Riley stated that while he would like to see qualified individuals on the Charter Commission, in his opinion it is not the position of the Council to be involved.

City Administrator Ulrich agreed that it would be best for the Council to remain uninvolved as the Charter Commission is meant to be a system of checks and balances with the Council.

Councilmember Williams arrived.

2.02: Discussion Regarding the Process for the City Administrator's Annual Review

Mayor Strommen provided background information, noting that she had asked for this discussion to occur to ensure that the current process is working smoothly and everyone is getting what they need out of the process as set up.

Human Resources Manager Lasher stated that this is just a discussion on the process used to review the City Administrator's performance and is not a discussion of his job performance as that would be done in a closed session. She reviewed the staff report.

Mayor Strommen asked whether the current process regarding the review criteria is working well or whether the Council would want to be more involved and have the criteria more finely tuned for the year.

Councilmember Johns stated that she would be in agreement with further discussing the review criteria.

Councilmember LeTourneau stated that he would like a more comprehensive review of the professional development plan, noting that perhaps something similar to the 360 tool could be used to do that. He noted that the tool would help to identify strengths and weaknesses noting that the information could then be used to build the work plan. He stated that the tools do not have an additional cost and would provide additional information.

Councilmember Riley stated that in the past there was more focus on the plan but noted that the process has evolved as the Council did not believe that was as important. He noted that the effort put into that a few years prior developed the plan which the Council is satisfied with. He stated that it appears that the tool would be helpful.

Mayor Strommen stated that she was disappointed with the lack of comments from the Boards and Commissions, noting that perhaps the tool was not working well and that is why they were not providing their feedback.

City Administrator Ulrich stated that he likes the idea of a new tool that would be geared more towards development. He noted that in regard to the Boards and Commissions perhaps some are not providing input because they do not really have much interaction with him and therefore they do not feel comfortable commenting. He stated that perhaps he should be engaging those folks more than is currently done. He thanked the Council for their participation in the process and for taking the time to complete the surveys.

Human Resources Manager Lasher stated that she would develop a list which she will bring back to the Council to review.

2.03: City of Ramsey Street Banners

Public Information and Events Specialist Wenberg reviewed the staff report.

Councilmember Kuzma asked if staff has considered looking for a sponsor, noting that the theme could appear on the top with a sponsored by section at the bottom.

Public Information and Events Specialist Wenberg stated that she did not originally consider that option but noted an example in New Hope where the banners were designed by college students and credit was given at the bottom.

Councilmember Kuzma stated that he would want the City to have control over the design and theme but noted that a section on the bottom could specify sponsored by and the name of the local business, which would assist with funding.

Mayor Strommen asked the goal of the banners.

Asst. City Administrator/Economic Development Manager Brama stated that this item was brought before the Council because of the request for further discussion. He noted that this

discussion could be postponed and brought forward with the communications program in order to make a more coordinated effort. He noted that at this time there is not a goal specified.

Mayor Strommen stated that she could think of ideas such as branding or identification of areas but noted that she would not be interested in investing funds without a goal. She stated that the goal would need to be identified and it would need to be determined if this would be the best method to reach that goal.

Councilmember LeTourneau stated that the broader picture is the image for the community and where the efforts need to be focused in order to create that image. He stated that, in his opinion, the Highway 10 and 47 corridors would be the primary objectives, noting that other priorities would then fall under those. He stated that while the banners are important he would view those as a second or third level opportunity.

Councilmember Shryock stated that she does see the banners could be used to identify a place and assist with branding but was not sure that this was the right time. She believed that there is more work to do before this discussion should occur, such as identifying areas and locations for banners.

Councilmember Riley stated that he brought this issue up because a resident brought up the issue to him. He stated that it was brought to him at the Christmas tree lighting that the main street is not decorated, noting that other cities have banners along their main street. He stated that he was impressed with the cost as he thought the cost would be higher. He agreed that perhaps the timing is not right as the Highway 10 and 47 corridors are important, but noted that he is not seeing anything getting done in those areas.

Mayor Strommen stated that perhaps the Council should have another discussion regarding the streetscaping for that main street. She noted that a goal would still need to be identified to determine if banners is the right answer and fit for the streetscape.

Councilmember Kuzma stated that he likes graphics and the banners would project a sense of pride in the community. He stated that in his opinion the cost looks high and he believed could be lowered to provide a low cost option to make the main street look nicer. He stated that he would be happy to share some knowledge with staff.

Mayor Strommen stated that she would like the Council to be clear on what is trying to be achieved. She noted that if the focus is streetscaping, then the Council should review examples from other cities to determine the look they are attempting to define for the area and how best to reach that goal.

City Administrator Ulrich stated that there are sections of the streetscaping that have been completed as development has been completed and noted that as development continues to be completed the streetscaping will be filled in. He acknowledged that the streetscaping is scattered and noted that perhaps banners would be a good idea to tie that all together in the meantime. He agreed that a theme would need to be identified in order to tie in the banner with the brand of the

City. He used the example of Anoka which has a theme that identifies with their image and has placement throughout their concentrated downtown area.

Councilmember Riley stated that if there was a way to do the banners along Highway 10 or Highway 47 they would be more effective but acknowledged that there is a specific place where the banners could be deployed.

Councilmember LeTourneau stated that he would like an opportunity to talk about streetscaping, not only along Sunwood but also what could be done along Highway 10 and Highway 47. He noted that once those plans are developed then a priority could be set for those corridors. He stated that the broad concept would provide the consistency, theme and design.

Councilmember Shryock stated that if that is done now there may be more focus on Happy Days and the holidays and that could evolve into the remaining parts of the year. She stated that there should be something that ties the City together so people know they are still in Ramsey and other elements that identify certain areas of the City.

Councilmember Riley stated that while that sounds like a good idea, he was concerned that this would turn into a two-year discussion and nothing is done.

City Administrator Ulrich stated that perhaps it would be a good idea to bring in a professional landscaper and/or design consultant to assist in this development.

Mayor Strommen confirmed the consensus of the Council to have a broad discussion regarding streetscaping in a timely manner.

3. TOPICS FOR FUTURE DISCUSSION

3.01: Review Future Topics/ Calendar

Councilmember Kuzma stated that perhaps signage in the City should be discussed as some signs need repair and/or updating.

Councilmember Williams stated that having the streetscaping discussion will help the City with the desired beautification process along Highway 10 and Highway 47.

City Administrator Ulrich stated that there will be insurance funds collected for the sign that was damaged at the corner of Highway 47 and Bunker Lake Boulevard and the Council would need to determine whether they wanted to replace the sign and the type of sign that they would want in that location.

Councilmember Riley stated that in his opinion the sign should be bigger and better than it was previously.

Councilmember Shryock stated that she believed that in the past discussions regarding a pedestrian bridge, there was talk about signage and believed that perhaps the signage would be done in stone and would be visible from Highway 10.

Councilmember Kuzma stated that the oil trains have picked up again and noted that he would like to have a worksession regarding safety and disaster protocol as there is a new Fire Chief.

Mayor Strommen stated that it is helpful for the Council to do a periodic review.

City Administrator Ulrich noted that staff is in the process of updating the Emergency Management Plan and once complete a presentation can be done to the Council. He advised that at the next meeting Community Development Director Gladhill will be making a presentation regarding the housing stock.

Councilmember LeTourneau asked and received confirmation that the presentation would be made at the regular Council meeting so that the presentation would be broadcast.

There was a discussion of the Council regarding the disconnect residents see between what is developing in The COR and what the original focus for that development was.

4. MAYOR / COUNCIL / STAFF INPUT

None

5. ADJOURNMENT

The Work Session of the City Council was adjourned at 6:42 p.m.

Respectfully submitted,

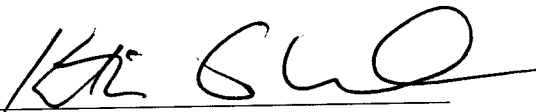

Kurtis G. Ulrich
City Administrator

ATTEST:

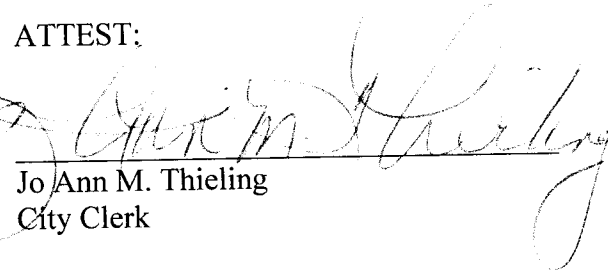

JoAnn M. Thieling
City Clerk

Drafted by Amanda Staple
TimeSaver Off Site Secretarial, Inc.



January 24, 2017

Mr. Tim Gladhill
Community Development Director
City of Ramsey
7550 Sunwood Drive NW
Ramsey, MN 55303

**RE: City of Ramsey – Key Nodes & Streetscapes
Landscape Architectural Services, Fee Proposal**

Dear Tim,

As per our discussion Tuesday and the briefing information provided by Eric and yourself for this project, please refer to the following summary. We have broken down the work into specific areas and have also grouped items as discussed. We would be happy to provide further detail and additional pricing for work beyond the outlined scope, if required.

INITIAL CONCEPTS

- Project establishment - based on briefing meeting
- Develop format for presentation of information (city-wide and site specific elements)
- Develop bases and concept layouts for up to five scenarios (hand sketches) including two site specific concepts for the specified sites below and three typical scenarios (S-M-L):

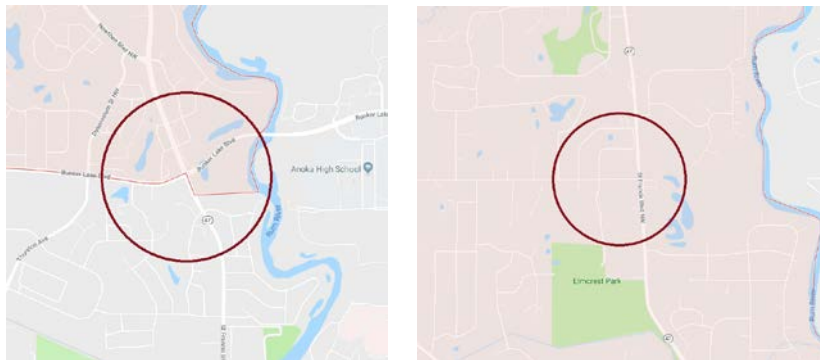

- Northwest of Bunker Lake Boulevard and Highway 47, which used to have a City of Ramsey sign in the corner, which was removed after an accident with a car and was never replaced. The City is seeking a conceptual design showing street lighting with banners as well as landscaping and signage.
- 167th Avenue NW between Quicksilver Street NW and Hwy 47, the City is seeking a conceptual design showing street lighting with banners as well as landscaping, addressing frontages and potential re-arrangement of the existing boulevard.

The three typical scenarios will consider and show the location of landscape plantings, street lighting, lighting, community sign (whether it is small, medium, or large) and banner poles. Some Example locations that may inform the 3 typical scenarios include (refer images below):

- Bunker Lake Boulevard and Ramsey Boulevard NW
- Bunker Lake Boulevard and Sunfish Lake Boulevard NW
- And the East and West Gateways to Ramsey on Highway 10



- Develop options for signage elements based on small, medium, or large scenarios
- Clarify preferred species for tree and other plantings and develop planting scenarios for the site-specific designs and short list for typical scenarios.
- Presentation of design concepts and design workshop with project specific City staff

Stage Subtotal \$4,182.00

REFINED CONCEPTS

- Incorporate Feedback from client review with City staff
- Refine graphics, if required, for the up to five total scenarios, including refining the concept design for two specific sites
- Prepare refined images of the small, medium, or large sign options with annotations for materials and dimensions
- Package work into a small (pdf) document format for distribution and presentation to Council
- Submission of final package to the client for presentation to Council.

Stage Subtotal \$2,879.00

We have proposed a highly-experienced team, each with unique skills and talents. We are confident in our ability to deliver a project of exceptional quality. WSB understands your desire to present this work at your March internal review meeting. We will strive to deliver the best possible outcome, meet your timelines, and exceed your expectations. We propose a lump sum cost of **\$7,061.00** for this project.

We appreciate the opportunity to submit this proposal and look forward to working with you on this exciting project. If you would like us to proceed with the above work, please sign the statement provided at the bottom of this letter and return the executed copy to me at your convenience. If you have any questions, please contact me at 612-201-0398.

Sincerely,
WSB & Associates, Inc.

Carlo Missio
Senior Urban Designer

Jason L. Amberg, RLA
Principal / Landscape Architecture Group Manager

City of Ramsey

By: _____

Title: _____

Date: _____

Meeting Date: 06/14/2016

Information

Title:

City of Ramsey Street Banners

Purpose/Background:

At a previous Council work session, staff was requested to bring back a case to present information regarding street banners.

The purpose of this case is to:

- (A) Generally confirm the Council's position on deploying street banners (is this initiative important to the Council?).
- (B) If deploying street banners is a priority for the Council, staff would like to discuss high-level scope, which will guide staff for a subsequent work session case (desired quality, design, quantity, timing, and locations?).

The City had a street banner program about 5-6 years ago. The banners were relatively small, not well-designed for their locations, and were installed using self-fabricated brackets (to reduce cost) that required significant maintenance due to breakage. The banners were removed from the COR after about two years.

Attached to this case are example banner orders, along with estimated pricing. Pricing is dependent on quality of bracket hardware, size and shape of banner, quantity of banners, artwork created or provided, etc. Staff will follow up with a specific street banner proposal, and alternatives, based on Council direction

Timeframe:

20 minutes

Funding Source:

2016 Marketing Budget

Responsible Party(ies):

Nichole Wenberg

Outcome:

The purpose of this case is to:

- (A) Generally confirm the Council's position on deploying street banners (is this initiative important to the Council?).
- (B) If deploying street banners is a priority for the Council, staff would like to discuss high-level scope, which will guide staff for a subsequent work session case (desired quality, design, quantity, timing, and locations?).

Attachments

Example Street Banner Quotes

Example Banners & Brackets

Inbox

Patrick Brama
Kurt Ulrich
Nichole Wenberg (Originator)
Patrick Brama
Nichole Wenberg (Originator)
Patrick Brama
Kurt Ulrich
Nichole Wenberg (Originator)
Kurt Ulrich
Form Started By: Nichole Wenberg
Final Approval Date: 06/09/2016

Reviewed By

Patrick Brama
Jo Thieling
Jo Thieling
Kathy Schmitz
Nichole Wenberg
Patrick Brama
Kathy Schmitz
Nichole Wenberg
Kurt Ulrich

Date

06/09/2016 10:08 AM
06/09/2016 10:16 AM
06/09/2016 10:21 AM
06/09/2016 11:06 AM
06/09/2016 11:21 AM
06/09/2016 11:54 AM
06/09/2016 02:31 PM
06/09/2016 03:17 PM
06/09/2016 03:37 PM
Started On: 05/31/2016 12:01 PM

For Reference Only.
Not part of 2/12/18 Request

BANNER PRODUCTION & HARDWARE:

Pricing is for double-sided, 55" x 24" vinyl banners + hardware for round light poles, one flag per pole (does not include installation).

Quantity of Banners	Number of Artwork Designs	Type of Hardware	Estimated Cost
<u>Red Leaf Design</u>			
50	1 design	Spring loaded brackets	\$12,760
50	4 designs	Spring loaded brackets	\$12,870
100	1 design	Spring loaded brackets	\$21,560
100	4 designs	Spring loaded brackets	\$21,670
<u>Northern Lights Display</u>			
50	1 design	Spring loaded brackets	\$9,350
50	4 designs	Spring loaded brackets	\$9,500
100	1 design	Spring loaded brackets	\$17,800
100	4 designs	Spring loaded brackets	\$18,100
<u>Grafix Shoppe</u>			
50	1 design	Non-spring loaded brackets	\$5,035.89
50	4 designs	Non-spring loaded brackets	\$5,296.27
100	1 design	Non-spring loaded brackets	\$8,257.14
100	4 designs	Non-spring loaded brackets	\$8,498.73

ARTWORK CREATION:**Red Leaf Design:**

- 1 design= \$500-750
- 4 designs (same layout, alternating between 2 colors & various photos) = \$600-850

EXAMPLE BANNERS



last updated: 5/13/11

Street Banner Displays in Roseville
brief

24" x 48" banners - a set of 8



Roseville Housing and Redevelopment Authority / Jeanne Kelsey, Housing Program Manager | 651-792-7088 | jeanne.kelsey@roseville.mn.us

page 1 of 4



All designs remain the property of Northern Lights Display and cannot be duplicated without their expressed written permission

12255319_6

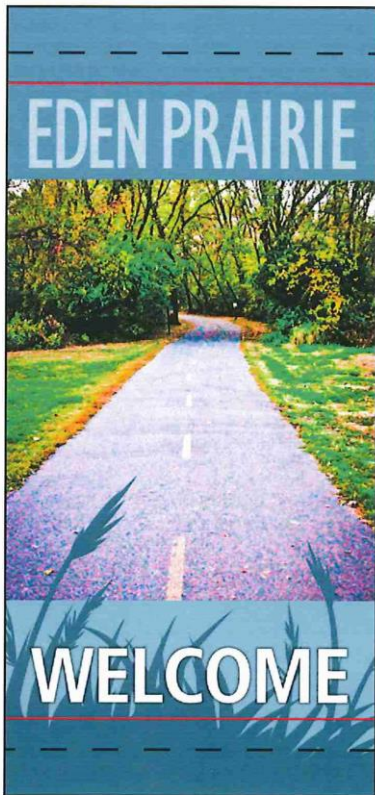

3" Pocket
← Safety Area

← Safety Area
3" Pocket

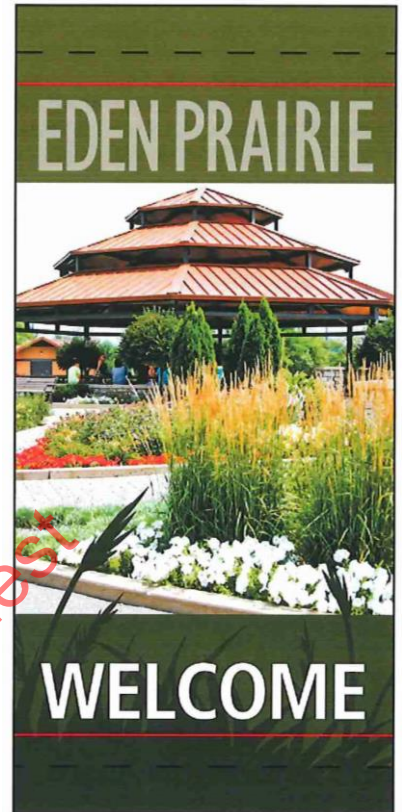

FINISH SIZE: 51" h x 24" w





For Reference Only.
Not part of 2/12/18 Request



EXAMPLE BRACKETS

Non-spring loaded:



Spring loaded:

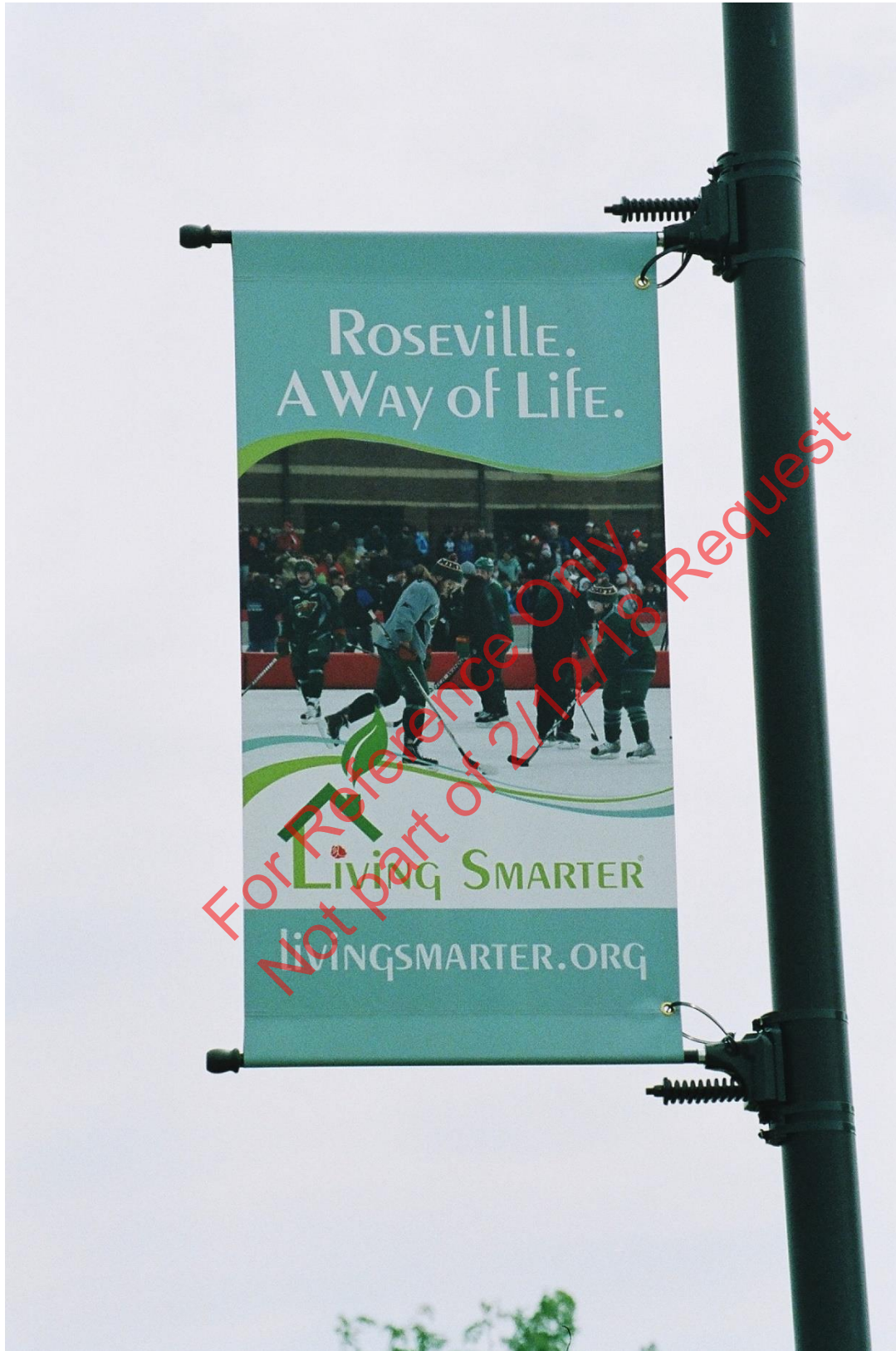

Meeting Date: 02/12/2018

Information

Title:

Policy for Televising Board and Commission Meetings and Attendance from Remote Location

Purpose/Background:

Currently all regular Council meetings and Commission meetings are broadcast via cable television (QCTV) except for the Environmental Policy Board (EPB) and the Economic Development Authority (EDA). To further the City's communication goal of open communication, staff is recommending the Council consider cablecasting the EPB and EDA meetings via QCTV as well.

Items of a confidential nature (such as real estate negotiations) would still be held in closed sessions. Meetings would be live-streamed as well as achieved on the QCTV web site. Since many projects involve review by several of different commissions, this would give the Council and other Commission members an opportunity to review discussions on tape. The location of the meetings would be moved to the Council chambers in order to facilitate the cablecast. This would have the added advantage of freeing-up meeting space to other user groups (since we do not normally rent out Council chambers space).

In addition, staff has been asked to research the attendance of Council and Commission members from a remote location. The City Attorney's memo on this issue is attached for discussion. At this point in time, the law allows attendance via "interactive television" with full voting rights under the conditions outlined by the City Attorney. In the future, this does appear to allow members more flexible meeting options, however the City may be limited by the available technology. Staff is seeking discussion and direction regarding additional policy in regard to this issue.

Timeframe:

EPB and EDA meetings could begin cable televised meetings as soon as March 2018. Meeting locations would need to be moved to the Council chambers.

Funding Source:

Not applicable. Televising the EPB and EDA regular meetings would have no additional cost to the City and would be absorbed by the existing QCTV budget.

Responsible Party(ies):

City Administrator

Outcome:

Consensus direction regarding cablecast of EPB and EDA meetings, and policy direction regarding remote attendance at public meetings.

Attachments

Council Remote attendance

Form Review

Inbox	Reviewed By	Date
Kurt Ulrich	Kurt Ulrich	02/08/2018 04:25 PM

Form Started By: Kathy Schmitz
Final Approval Date: 02/08/2018

Started On: 02/08/2018 03:43 PM

MEMORANDUM



TO: Kurt Ulrich

FROM: Joseph J. Langel, City Attorney

DATE: February 6, 2018

RE: Remote attendance at public meetings

You indicated that elected and/or appointed officials in Ramsey inquired about whether and how they can attend public meetings remotely. This inquiry raised some related questions as well, which are discussed below.

Issues

1. What options are available under the Open Meeting Law?
2. Are there any restrictions?
 - a. How many members can be absent at the same time?
 - b. Are there specific requirements at the remote location?
 - c. Are there specific requirements at the regular location?
3. How does this impact voting rights and quorum requirements?
4. Are there special notice requirements if one or more members are attending remotely?

Discussion

1. Remote Options Available under the OML

The Open Meeting Law (OML), Minnesota Statutes section 13D.02, subdivision 1, allows a meeting to be conducted by interactive television. In Minnesota Department of Administration Advisory Opinion 13-009, the use of Skype was deemed suitable under the OML, given its similarity to interactive television. It is likely that software similar to Skype, such as FaceTime, would also be allowed under these provisions.

Note that the ability to use “a telephone or other electronic means” is available only to state agencies. *Minn. Stat. § 13D.015*. The League has suggested that this option be broadened to include cities, but that has not occurred. Consequently, only the “interactive television” option, or its equivalent, is available to cities, meaning combined audio-visual is required; having a member on speaker phone does not suffice.

2. Restrictions on Remote Options

a. How many members can be absent at the same time?

As long as one member is physically present at the regular meeting location, the rest of the council, board or commission can appear via one or more remote links.

b. Are there specific requirements at the remote location?

The remote location that a member is participating from is to be open and accessible to the public. *Minn. Stat. 13D.02 subd. 1(4)*. According to Advisory Opinion 13-009, this location can be outside the city. It is not required that the location be convenient for city residents; it just has to be open to the public. This can get a little awkward when the remote attendee is in a hotel room or relative's home and should be taken into consideration when choosing the remote location. Any member of the public showing up at the remote location must be able to see and hear all discussion and votes, which means the remote member may be sharing a computer screen with someone.

Note that *all* members of the body must be able to hear and see one another. This must be taken into account when considering camera and screen placement in the room. If there are two or more remote attendees, this can create substantial technical issues that must be worked out prior to the meeting.

Not only can the public be present at the regular meeting site and the remote site, the OML also allows the public to "monitor" the meeting electronically from a remote location "to the extent practical" if interactive television or its equivalent is being used. Any incremental costs incurred by the City to make that available may be charged to the person requesting it.

c. Are there specific requirements at the regular location?

At the regular location, both the public and the other members must be able to hear and see the member attending the meeting remotely. This may require more than one screen, depending on the room layout.

3. How does this impact voting rights and quorum requirements?

Voting rights are not impacted by remote attendance and a member attending remotely is considered present at the meeting for purposes of determining a quorum.

4. Are there special notice requirements if one or more members are attending remotely?

If interactive television or its equivalent are used, the city “shall provide notice of the regular meeting location and notice of any site where a member of the public body will be participating in the meeting.” *Minn. Stat. § 13D.02, subd. 4*. The timing and method of notice is the same as with any other meeting of that kind (i.e., regular, special or emergency). Note, however, that if a regular meeting location changes (which would be the case if someone is attending remotely), notice must given in the same manner as a special meeting, meaning posted three days before the date of the meeting and mailed to whomever requested such notices. *Minn. Stat. § 13D.04*.

As a practical matter, this means that the member who is to appear remotely must inform City staff of the site where he or she will be for the meeting, and do so early enough that staff can post and mail a timely notice.

Meeting Date: 02/12/2018

Information

Title:

Discussion Regarding Proposed Updates to the Personnel Policy

Purpose/Background:

The purpose of this discussion is to provide the City Council with information on proposed updates to the Personnel Policy and to seek feedback regarding any revisions the City Council would like to see included in the updated policy.

The current Personnel Policy was adopted August 11, 2014; prior to that, it was updated in 2006. Since 2014, a few individual policies were added, on an as-needed basis, and approved by the City Council. Staff anticipates this discussion to be the less extensive than in the past; however, if needed, an additional work-session will be added prior to adopting the updated policy.

The focus of the proposed updates are primarily driven in order maintain a legally compliant policy -- reducing risk to the City; to more clearly define respectful employee conduct and processes for reporting unacceptable conduct; and to provide a defensible reference to which applicable employees or others shall be held accountable.

The scope of the Personnel Policy generally applies to all City employees, including probationary employees, elected officials, and appointed officials. Certain provisions of the policy may be inapplicable to certain individuals, as listed in the policy.

Employees included in a collective bargaining agreement entered into in accordance with the Public Employment Labor Relations Act (PELRA) shall be exempt from any provision of this policy that is inconsistent with such agreement.

To date, the policy has been reviewed by the following groups:

Management Team;

Labor Management Committee;

Safety Committee; and

Initial review by City Attorney Langel's partner – Christian Shafer

Note: The attorney's final review will occur after any additional proposed changes have been drafted.

Staff will provide information during the work-session regarding the proposed updates to the current Personnel Policy, which is attached. A final marked-up draft of the policy with all proposed updates will be provided prior to adoption.

Timeframe:

This meeting: Approximately 15 minutes

Additional meetings, if needed: 15 - 30 minutes

Funding Source:

Not applicable.

Responsible Party(ies):

Colleen Lasher, Human Resources Manager

Outcome:

To progress toward an updated Personnel Policy, to be adopted by resolution in the coming weeks.

Attachments

Personnel Policy

Form Review

Inbox

Kurt Ulrich
Colleen Lasher (Originator)
Kurt Ulrich
Form Started By: Colleen Lasher
Final Approval Date: 02/08/2018

Reviewed By

Colleen Lasher
Colleen Lasher
Kurt Ulrich

Date

02/08/2018 08:41 AM
02/08/2018 11:15 AM
02/08/2018 03:03 PM
Started On: 01/26/2018 11:32 AM



PERSONNEL POLICY

August 11, 2014

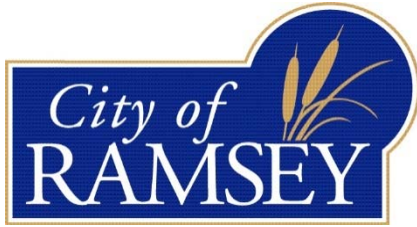

Dear City of Ramsey Employee:

The city of Ramsey is a vibrant, growing community that promotes excellence in everything we do and we are pleased to have you on our team.

As part of our team, you are expected to behave in a consistent manner with the City's mission and vision, core values, guiding principles, and this personnel policy.

This personnel policy was prepared to generally describe the terms, conditions, benefits, rights, and responsibilities of employment. The application of specific sections of this policy to any particular situation may depend on the specific facts or conduct at issue. Please become familiar with this personnel policy within ten (10) business days of your receipt of this policy. I hope you will find the policy informative and useful in making the most of the many opportunities available to you as a City employee.

After you have had an opportunity to familiarize yourself with the personnel policy, you must sign the last page of the policy, entitled "Acknowledgement of Receipt of the city of Ramsey Personnel Policy," and submit it to the Human Resources Office. Should you have questions regarding the personnel policy or any aspect of your employment relationship with the City, please feel free to contact me or your supervisor.

Sincerely,

A handwritten signature in cursive script that reads "Colleen Lasher".

Colleen Lasher
Human Resources Manager

TABLE OF CONTENTS

TABLE OF CONTENTS	3
SECTION 1 INTRODUCTION.....	5
1.1 HOW TO USE THIS PERSONNEL POLICY.....	5
1.2 SCOPE OF POLICY	5
1.3 EMPLOYEE RESPONSIBILITY.....	6
1.4 DATA PRACTICES ADVISORY:.....	6
1.5 EQUAL EMPLOYMENT OPPORTUNITY STATEMENT	7
1.6 UNLAWFUL ACTS.....	8
1.7 EXCEPTIONS	8
SECTION 2 DEFINITIONS	9
SECTION 3 EMPLOYEE RECRUITMENT, SELECTION, EMPLOYMENT & TERMINATION.....	11
3.1 SCOPE	11
3.2 FEATURES OF THE RECRUITMENT SYSTEM	11
3.3 TESTING AND EXAMINATIONS	11
3.4 PRE-EMPLOYMENT MEDICAL EXAMS	11
3.5 SELECTION PROCESS.....	13
3.6 BACKGROUND CHECKS.....	13
3.7 CRIMINAL BACKGROUND INVESTIGATIONS.....	13
3.8 TRAINING PERIOD.....	14
3.9 RECLASSIFICATION AND NEW POSITION / VACANT POSITION.....	14
3.10 NEPOTISM.....	14
3.11 PROBATION.....	15
3.12 SUPPLEMENTAL EMPLOYMENT	15
3.13 PERFORMANCE EVALUATIONS.....	15
3.14 RESIGNATIONS	16
3.15 LAY-OFFS.....	16
SECTION 4 BENEFITS.....	17
4.1 GROUP INSURANCE	17
4.2 LONG TERM DISABILITY (“LTD”).....	17
4.3 PUBLIC EMPLOYMENT RETIREMENT ASSOCIATION (“PERA”)	17
4.4 DEFERRED COMPENSATION	17
4.5 FLEXIBLE SPENDING ACCOUNT	18
4.6 RETIREE BENEFITS.....	18
4.7 COBRA	18
4.8 EMPLOYEE ASSISTANCE PROGRAM	18
SECTION 5 CLASSIFICATION AND COMPENSATION	19
5.1 GENERAL.....	19
5.2 CLASSIFICATION PLAN / POSITION DESCRIPTIONS	19
5.3 RECLASSIFICATION	20
5.4 COMPENSATION PLAN	21
5.4 PAYROLL DEDUCTIONS.....	22
5.5 MEAL PERIODS AND BREAKS.....	23
5.6 OVERTIME COMPENSATION/COMPENSATORY TIME OFF	23
5.7 SEVERANCE PAY	24
SECTION 6 LEAVE	25
6.1 VACATION LEAVE	25
6.2 SICK LEAVE.....	27
6.3 HOLIDAYS	29
6.4 FAMILY AND MEDICAL LEAVE.....	30
6.5 EXTENDED MEDICAL LEAVE	32
6.6 BONE MARROW DONATION LEAVE.....	33
6.7 TEMPORARY LIGHT DUTY.....	33

6.8	MILITARY LEAVE	34
6.9	PARENTING LEAVE	34
6.10	SCHOOL CONFERENCE AND ACTIVITIES LEAVE	34
6.11	JURY OR WITNESS DUTY	35
6.12	FUNERAL LEAVE	35
SECTION 7	CONDUCT	36
7.1	CODE OF CONDUCT	36
7.2	HARASSMENT POLICY	39
7.3	WORKPLACE VIOLENCE POLICY	40
7.4	DOMESTIC VIOLENCE	42
7.5	APPEARANCE AND DRESS POLICY	42
7.6	OFF-DUTY CONDUCT	44
7.7	EMPLOYEE PARKING	45
7.8	CONFLICT OF INTEREST AND DIVIDED ALLEGIANCE	45
SECTION 8	DISCIPLINE/GRIEVANCE PROCEDURES	49
8.1	DISCIPLINE	49
8.2	GRIEVANCE PROCEDURE	50
SECTION 9	TRAVEL, TRAINING AND EDUCATION	52
9.1	TRAVEL POLICY	52
9.2	TRANSPORTATION/AIRLINE TRAVEL CREDITS	52
9.3	MILEAGE REIMBURSEMENT	53
9.4	LODGING	53
9.5	MEALS	53
9.6	TRAINING AND EDUCATION POLICY	54
SECTION 10	HEALTH AND SAFETY	56
10.1	POLICY STATEMENT	56
10.2	HEALTH AND PERSONAL SAFETY	56
10.3	WORKERS' COMPENSATION / INJURIES AND ILLNESS AT WORK	56
10.4	MEDICAL PROCEDURES	57
10.5	SMOKING POLICY	57
10.6	INCLEMENT WEATHER POLICY	57
10.7	MUNICIPAL CENTER SEVERE WEATHER PLAN/OTHER EMERGENCY PLAN	57
10.8	HEPATITIS-B VACCINE POLICY	59
10.9	HOUSEKEEPING	59
SECTION 11	USE OF CITY PROPERTY	60
11.1	PUBLIC INFORMATION	60
11.2	TELEPHONE USE	60
11.3	INFORMATION TECHNOLOGY POLICY	60
11.4	VEHICLE USE POLICY	69
11.5	TELECOMMUTING POLICY	70
SECTION 12	DRUG FREE WORKPLACE POLICY	72
12.1	DRUG FREE WORKPLACE POLICY STATEMENT	72
12.2	DRUG AND ALCOHOL TESTING	72
SECTION 13	ACKNOWLEDGEMENT OF RECEIPT OF THE PERSONNEL POLICY	80

SECTION 1 INTRODUCTION

1.1 How to use this Personnel Policy

This personnel policy is provided as a reference and as a summary of the city of Ramsey's personnel policies, work rules, and benefits. It replaces, revokes, and supersedes any previous personnel policies, interpretations, or practices, and is only valid until amended or replaced by the City Council. Accordingly, you will find it to your advantage to read the entire personnel policy promptly so that you will have a complete understanding of the material covered.

The purpose of this personnel policy is to provide for a safe, orderly, and disciplined employment environment. This policy will promote knowledge of what is expected of personnel generally, which should result in a greater degree of self-assurance in all positions. In relationships between positions it should be each City employee's individual aim to build mutual respect and confidence which is essential to local government service.

Any local, state, or federal laws that impose stricter requirements or regulations shall be used in lieu of policies or procedures outlined in this personnel policy, whenever they apply.

Additional information or clarification as to each section of this personnel policy may be obtained from your supervisor, Department Head or the Human Resources Manager. The text of this policy, however takes precedence over and controls any inconsistent communication from any City employee or elected official.

This personnel policy summarizes the various policies and benefits currently provided by the city of Ramsey. Nothing contained in this personnel policy or in any other City document, and nothing said or done by a City employee, may be construed as an employment contract between the City and an employee, a guarantee of continued employment, or terms and conditions of employment. The City and the employee both have the right to terminate the employment relationship at any time. Except as modified by an individual contract or a collective bargaining agreement, all employment with the City is "at-will" employment.

The City reserves the right to modify, revoke, suspend, or change this personnel policy, in whole or in part, at any time, with or without notice, at the City Council's sole discretion.

1.2 Scope of Policy

This personnel policy generally applies to all City employees, including probationary employees, elected officials, and appointed officials. Certain provisions of this policy may be inapplicable to the following individuals:

- 1) Elective officials;
- 2) Appointed personnel; i.e. City Attorney and Health Officer;
- 3) Members of City boards, commissions, and committees;
- 4) Paid-on-call Firefighters and volunteer personnel;
- 5) Emergency employees who are employed for emergency work caused by natural disaster;
- 6) Other employees working temporarily, less than 14 hours per week.

Any employee included in a collective bargaining agreement entered into in accordance with the Public Employment Labor Relations Act shall be exempt from any provision of this policy that is inconsistent with such agreement. Any employee within the jurisdiction of a personnel board or civil service commission established under Minnesota state law is exempt from any provision of this policy that is inconsistent with such statute or rules and regulations adopted hereunder. Nothing in this Section is intended to modify or supersede any provision of the Minnesota Veterans' Preference Act.

1.3 Employee Responsibility

It is the individual employee's responsibility to know and understand thoroughly the policies and subjects covered in this personnel policy. Updated material may be added periodically. Each employee is responsible for going over any new material added. Any questions about the material covered in this policy can be answered by the employee's supervisor, Department Head or Human Resources.

1.4 Data Practices Advisory:

In accordance with the Minnesota Government Data Practices Act, the City is required to inform employees of their rights as they pertain to any private information that the City collects from them. During the course of City employment, an employee will likely be asked to provide information which is classified by state law as either private or confidential. Private data is information which generally cannot be given to the public but can be given to the subject of the data. Confidential data is information which generally cannot be given to either the public or the subject of the data. Much of the data the City has about individual employees, however, is classified as public according to Minnesota Statutes, section 13.43, subdivisions 2 and 3. All public data is available for inspection and copying by members of the public, with or without the employee's consent.

Information about employees requested by the City may be used for the following purposes: (1) process payroll, including accounting for wages and fringe benefits and to justify any reimbursed expenses; (2) enroll in benefit programs and pension plans (3) evaluate the employee's job performance, eligibility and abilities; (4) distinguish the employee from other applicants and employees and identify the employee in the correct personnel file; (5) determine the employee's eligibility for employment or promotion, and make employment decisions about the employee's performance; (6) contact the employee or other significant persons in case of an emergency; (7) compile equal opportunity and affirmative action reports; (8) make decisions regarding the employee's eligibility for sick leave, family and medical leave, parenting leave, and other available leave; (9) make decisions regarding the employee's eligibility for workplace accommodations, including accommodations for disabilities; (10) comply with workers compensation requirements in the event of an injury; and (11) provide information during workplace investigations. Such information may also be used and disclosed for other purposes consistent with applicable law. The information provided by the employee may be used in performance evaluations, determinations regarding merit pay, applications for different employment positions, and other matters which involve a review of the employee's personnel file and past performance.

Unless the employee is told otherwise, the employee is required to provide this information. If the employee refuses to supply the information, the employee may face disciplinary action. Any information which the employee is required to provide cannot be used against the employee in a criminal proceeding. Even if the employee is not required to provide information, it is generally to the employee's best interest to provide it. Without the requested information, the City may not be able to determine the employee's eligibility for employment opportunities, compute wages, or grant the employee other benefits. The employee's refusal to provide information during an employment investigation may also necessitate that the investigation be completed without his or her input.

Federal law permits government agencies to require individuals to provide their social security number for the administration of any tax. Please be aware that when an employee is asked to give his or her social security number on revenue forms, this collection is mandated by law. This information will be shared with the Minnesota Department of Revenue, the Internal Revenue Services, and security tax programs. In most other cases, the disclosure of an employee's social security number is voluntary.

Any information an employee is asked to provide may be shared with individuals within the City whose job duties reasonably require access, as well as individuals outside of the city whose duties require access, such as insurance vendors, consultants, attorneys, and retirement plan employees. Information may also be shared with other agencies authorized by law to receive specific data.

If litigation arises, the information may be provided in documents filed with the court which are available to any member of the public. If it is reasonably necessary to discuss the information at a City Council meeting, it will be available to members of the public. To the extent that some or all of the information is part of the basis for a final decision on disciplinary action, that information is available to any member of the public.

1.5 Equal Employment Opportunity Statement

This is to affirm the city of Ramsey's policy of providing Equal Opportunity to all employees and applicants for employment and complying with all applicable Equal Employment Opportunity/Affirmative Action laws, directives and regulations of Federal, State and Local governing bodies or agencies thereof. This policy extends to all applicants and employees and to all aspects of the employment relationship, including, but not limited to, recruiting, hiring, promotion, transfer, discipline, and compensation.

The city of Ramsey is an Equal Opportunity Employer. The City provides equal employment and advancement opportunity on the basis of merit within the context of its unique business environment and without regard to race, color, creed, religion, national origin, sex, sexual orientation, disability, age, marital status, familial status, status with regard to public assistance, or any other characteristic protected by state or federal law.

The city of Ramsey will take affirmative action to ensure that all employment practices are free of discrimination. Such employment practices include, but are not limited to the following; hiring, upgrading, demotion, transfer, recruitment or recruitment advertising, selection, layoff, disciplinary action, termination, rates of pay or other forms of compensation, and selection for training, including apprenticeship.

1.6 Unlawful Acts

No person shall knowingly make any false statement, certificate, mark, rating, or report in regard to any test, certificate, or appointment held or made under the City personnel system or in any manner commit or attempt to commit any fraud preventing the impartial execution of the provisions of this policy.

No person seeking employment to or promotion in the City service shall either directly or indirectly give, render, or pay any money, service, or other valuable consideration to any person, or on account of or in connection with the employee's test, appointment, or promotion, or proposed appointment or promotion.

No person shall be employed, promoted, demoted, or terminated by the City or in any way favored or discriminated against because of, race, creed, color, national origin, religion, sex, sexual orientation, marital status, familial status, age, status with regard to public assistance or disability, other characteristics protected by state or federal law, or because of actions taken with regards to the rights under provisions of the Public Employment Labor Relations Act. No person who is over 18 years of age shall be discriminated against with reference to City employment in any way forbidden by federal and state law.

1.7 Exceptions

No exception to any provision of this personnel policy may be made except by the City Administrator, the City Administrator's designee as noted in specific sections of this policy, or the City Council as required under the City's Charter. Such exceptions shall be made only on a case by case basis and only after the City Administrator or the City Council has adopted sufficient findings of fact showing the justification for the exception.

SECTION 2 DEFINITIONS

For purposes of these policies, the following definitions will apply:

Authorized Hours - The number of hours an employee was hired to work. Actual hours worked during any given pay period may be different than authorized hours, depending on workload demands or other factors, and upon approval of the employee's supervisor.

Benefits -Privileges granted to qualified employees in the form of paid leave and/or insurance coverage.

Benefit Earning Employees -Employees who are eligible for at least a pro-rated portion of some City provided benefits. Such employees must be year-round employees who work at least 20 hours per week on a regular basis.

Casual Employee – Temporary employees who periodically work “special projects” for the City such as the Pet Clinic, Elections and Happy Days. This classification includes, but may not be limited to, Rink Attendants, Snow Plow Drivers, and other employees working less than 14 hours per week.

Demotion -The movement of an employee from one job class to another within the City, where the maximum salary for the new position is lower than that of the employee's former position.

Direct Deposit -As permitted by state law, all City employees are required to participate in direct deposit.

Employee - An individual who has successfully completed all stages of the selection process including the training period.

Exempt Employee – Any employee excluded from overtime and compensatory time off provisions of the Minnesota and federal Fair Labor Standards Act (“FLSA”). **Non-Exempt Employee** – Employees who are covered by the federal or state Fair Labor Standards Act. Such employees are normally eligible for overtime pay or compensatory time off at 1.5 times their regular hourly wage for all hours worked over forty (40) in any given workweek.

FICA (Federal Insurance Contributions Act) - FICA is the federal requirement that a certain amount be automatically withheld from employees' earnings. Specifically, FICA requires an employee contribute a percentage for Social Security and for Medicare. The City contributes a matching percentage on behalf of each employee. Certain employees are exempt or partially exempt from these withholdings (e.g., police officers).

Fiscal Year -The period from January 1 to December 31.

Full-time Employee - Employees who are required to work forty (40) or more hours per week year-round in an ongoing position. In accordance with federal health care reform laws and regulations, the City shall offer health insurance benefits to eligible employees and their dependents that work on average or are expected to work 30 or more hours per week or the equivalent of 130 hours or more per month. In order to comply with Health Care Reform law while avoiding penalties, part-

time employees will be scheduled with business needs and in manner which ensures positions retain part-time status under which intended.

Hours of Operation - City Hall's hours of operation are Monday through Friday, from 8:00 a.m. to 4:30 p.m.

Part-time Employee - Employees who are required to work less than forty (40) hours per week year-round in an ongoing position. In accordance with federal health care reform laws and regulations, the City shall offer health insurance benefits to eligible employees and their dependents that work on average or are expected to work 30 or more hours per week or the equivalent of 130 hours or more per month. In order to comply with Health Care Reform law while avoiding penalties, part-time employees will be scheduled with business needs and in manner which ensures positions retain part-time status under which intended.

PERA (Public Employees Retirement Association) - Statewide pension program in which all City employees meeting program requirements must participate in accordance with Minnesota law. The City and the employee each contribute to the employee's retirement account.

Promotion - Movement of an employee from one job class to another within the City, where the maximum salary for the new position is higher than that of the employee's former position

Reclassify - Movement of a job from one classification to another classification because of a significant change in the position's duties and responsibilities

Seasonal Employee - Employees who work only part of the year (100 days or less) to conduct seasonal work. Seasonal employees may be assigned to work a full-time or part-time schedule. Seasonal employees do not earn benefits or credit for seniority.

Service Credit - Time worked for the City. An employee begins earning service credit on the first day worked for the City. Some forms of leave will create a break in service.

Supervisor – Any person having authority in the interests of the employer to perform or effectively recommend a majority of the following actions: hires, transfer, suspensions, promotions, discharges, discipline, reward, assignments and work direction, adjustment of grievances and performance evaluations.

Temporary Employee - Employees who work in temporary positions. Temporary jobs might have a defined start and end date or may be for the duration of a specific project. Temporary employees may be assigned to work a full-time or part-time schedule. Temporary employees do not earn benefits or credit for seniority.

Transfer – Movement of an employee from one City position to another of equivalent pay.

Work Week - The regular work week for City employees is forty hours, in addition to a lunch period, Monday through Friday, except as otherwise established by the City Administrator or designee in accordance with needs of the department.

SECTION 3 EMPLOYEE RECRUITMENT, SELECTION, EMPLOYMENT & TERMINATION

3.1 Scope

The City Administrator or a designee will manage the hiring process for positions within the City. While the hiring process may be coordinated by staff, the City Council is responsible for the final hiring decision and must approve all hires to City employment. All hires will be made according to merit and fitness related to the position being filled.

3.2 Features of the Recruitment System

The City Administrator or designee will determine if a vacancy will be filled through an open recruitment or by promotion, transfer or some other method. This determination will be made on a case-by-case basis. The majority of position vacancies will be filled through an open recruitment process. Position vacancies may be filled on an “acting” basis as needed.

Application for employment will generally be made on application forms provided by the City. Other materials in lieu of a formal application may be accepted in certain recruitment situations as determined by the City Administrator or designee. Supplemental questionnaires may be required in certain situations. All candidates must complete and submit the required application materials by the posted deadline, in order to be considered for the position. The deadline for application may be extended by the City Administrator. Unsolicited applications will not be kept on file.

3.3 Testing and Examinations

Applicant qualifications will be evaluated in one or more of the following ways: training and experience rating; written test; oral test or interview; performance or demonstrative test; physical agility test, or other appropriate job-related exam.

Internal recruitments will be open to any City employee who: (1) has successfully completed the initial training period; (2) meets the minimum qualifications for the vacant position; and (3) currently is and for the past year has been in good standing with the City.

The City Council or designee will establish minimum qualifications for each position with input from the appropriate supervisor. To be eligible to participate in the selection process a candidate must meet the minimum qualifications.

3.4 Pre-Employment Medical Exams

The City Administrator or designee may determine that a pre-employment medical examination, which may include a psychological evaluation, is necessary to determine fitness to perform the

essential functions of any City position. Where a medical examination is required, an offer of employment is contingent upon successful completion of the medical exam.

When a pre-employment medical exam is required, it will be required of all candidates who are finalists and/or who are offered employment for a given job class. Information obtained from the medical exam will be treated as confidential medical records.

When required, the medical exam will be conducted by a licensed physician designated by the City with the cost of the exam paid by the City. (Psychological/psychiatric exams will be conducted by a licensed psychologist or psychiatrist.) The physician will notify the City Administrator or designee that a candidate either is or isn't medically able to perform the essential functions of the job, with or without accommodations and whether the candidate passed a drug test, if applicable.

If the candidate requires accommodation to perform one or more of the essential functions of the job, the City Administrator or designee will confer with the physician and candidate regarding reasonable and acceptable accommodations.

If a candidate is rejected for employment based on the results of the medical exam, he/she will be notified of this determination.

3.5 Selection Process

The selection process will be a cooperative effort between the City Administrator or designee and the hiring supervisor, subject to final hiring approval of the City Council. Any, all or none of the candidates may be interviewed.

The City has the right to make the final hiring decision based on qualifications, abilities, experience and city of Ramsey needs.

3.6 Background Checks

All finalists for employment with the City will be subject to a background check to confirm information submitted as part of application materials and to assist in determining the candidate's suitability for the position. Except where already defined by state law, the City Administrator will determine the level of background check to be conducted based on the position being filled.

3.7 Criminal Background Investigations

Authority

State law authorizes city police departments to conduct criminal history background investigations on applicants for City positions using Minnesota Computerized Criminal History data.

Applications

This section applies only to applicants who are finalists for regular, temporary, and volunteer status positions. Before a finalist is eligible to receive a conditional job offer or begin employment with the City, the applicant must authorize the Police Department, in writing, to undertake a criminal history background investigation and to release the information to the City Council, City administrator and/or other City staff as appropriate.

Rejection of Applications

Except in the case of exceptions set forth in Minnesota state law, as may be amended from time to time, if the City rejects an application for employment due partly or solely to the applicant's prior conviction of a crime which relates directly to the position sought, the City's Human Resources Manager will notify the applicant in writing of the following:

- 1) The Grounds and reasons for denial;
- 2) The applicant complaint and grievance procedure set forth in Minnesota State law, as may be amended from time to time;
- 3) The earliest date the applicant may reapply for employment or a volunteer position; and
- 4) That all competent evidence of rehabilitation will be considered upon re-application.

Only public conviction information related directly to the position sought will be considered in denying employment. In situations where identity is questioned, fingerprint verifications will be allowed. The City reserves the right to consider the applicant's criminal history, including any and all evidence of rehabilitation, when evaluating him or her for employment with the City, to the maximum extent permitted by law.

3.8 Training Period

The training period is an integral part of the selection process and will be used for the purpose of closely observing the employee's work and for training the employee in work expectations. Training periods apply to new hires, transfers, promotions and rehires. Training periods are six months in duration, but may be extended by, for example, an unpaid leave of absence.

3.9 Reclassification and New Position / Vacant Position

Reclassification

When a position's duties and responsibilities change (increase or decrease), the position is considered a reclassification and may be automatically filled by the incumbent of the original position; contingent upon the incumbent's ability to meet the position's minimum requirements and necessary knowledge, skills, and abilities.

New Position

If the City creates a new position to meet its public service needs the position will be filled according to the City Administrator's direction.

3.10 Nepotism

The potential for conflicts of interest are increased when personnel who are related are employed by the same employer; and real or implied conflicts of interest can result in distrust and a general lack of harmony among other employees.

Whenever possible, and with due regard for job-relevant qualifications, merit, and fitness, the employer shall avoid the appointment of any person related to an appointed officer or regular full-

time or regular part-time employee of the City. Appointments or assignments of persons related to an employee in the same department in which the employee works is prohibited.

This provision does not apply to marital status or familial status, as protected under the Minnesota Human Rights Act. Employment of the spouse of an elected or appointed officer or employee is not prohibited; however, appointment or assignment of an employee's spouse in the same department in which the employee works is prohibited, if the appointment or assignment would result in an employee directly supervising or influencing the recruitment, employment, salary, fees, or performance review of the employee's spouse.

Appointment to a position with the City shall not be construed as an employment contract between the city of Ramsey and an employee. All employees whose positions are covered by this policy are appointed by - and serve - at the sole discretion of the employer.

3.11 Probation

Subject to the provisions of an applicable collective bargaining agreement, every original appointment and every promotional appointment, is subject to a probationary period of six (6) months, except for patrol officers, paid-on-call firefighters, and Department Heads who have a one-year probationary period. During the probationary period a probationary employee may be terminated at the sole discretion of the City. If terminated during the probationary period, the employee shall be notified in writing of the termination and shall have no right to appeal the termination.

Employees may use sick and vacation leave during their probationary period at the discretion of the Department Head.

Qualified veterans are protected by law and must be afforded certain benefits from the date of hire and may not be discharged without sufficient cause, as provided by law. If a veteran is proposed for discharge at any time, including the probationary period, the veteran will be afforded the rights provided in the Minnesota Veterans Preference laws. If such employee is a veteran, the procedure prescribed in Minnesota Statutes shall be followed.

At the sole discretion of the City Administrator, an employee's probationary period may be extended for 90 calendar days.

3.12 Supplemental Employment

No city of Ramsey patrol officer shall work as a police officer or keeper of the peace directly for any establishment in the City or at any special private functions within the City. Officers needed at special functions shall work as city of Ramsey employees and shall be paid directly by the City. The City, in return, will bill the person or entity requesting the officers' presence at the function from which payment the City will reimburse itself for the officers' services.

3.13 Performance Evaluations

Performance evaluations are used to assess employee performance in terms of specific job requirements and provide measures for setting up training and development programs for improvement and opening communication channels. On the anniversary date of an employee's

current position, or in January if so determined by the Human Resources Manager, as well as when an employee is completing their probationary period, a formal performance evaluation may be completed. If a formal performance evaluation is completed, it will be reviewed with the employee.

For Department Heads, the City Administrator will make note of any City Council feedback regarding Department Head performance and summarize the Council's comments when writing the Department Head's performance evaluation. The City Administrator will review the performance evaluation with the Department Head. The Department Head will have the opportunity to discuss the performance evaluation with the City Council at a closed City Council meeting if he/she so chooses.

The City will consider each employee's performance evaluation when considering salary increases or potential promotional opportunities. As a general rule, an employee who receives an overall rating of "Needs Improvement" or "Poor" will not be eligible for promotional opportunities, salary increases, except for any "cost of living" adjustment made by the City. Further, an employee who receives an overall rating of "Needs Improvement" or "Poor" must follow a performance improvement plan to bring performance to an acceptable level. If performance is not brought to an acceptable level as described in the performance improvement plan, discipline may be imposed, up to and including termination.

3.14 Resignations

As at-will employees, all City employees may resign at any time, for any reason. In order to be considered "in good standing" at the time of resignation, an employee must file with employee's Department Head, at least 14 days before leaving, a written resignation stating the effective date of the resignation. Department Heads wishing to resign "in good standing" should give the City as much advance notice as possible, but must provide at least 30 days' notice. Failure to comply with this 14 day or 30 day notice procedure may be considered cause for denying the employee future employment by the City and denying termination benefits. Unauthorized absence from work for a period of three working days may be considered by the Department Head as a resignation "not in good standing" and without benefits.

3.15 Lay-offs

After at least two weeks' notice to the employee, the City Administrator may lay off any employee when such action is necessary because of shortage of work or funds, the abolition of a position, or changes in organization.

SECTION 4 BENEFITS

4.1 Group Insurance

To be eligible for group health, dental, or life insurance benefits with the city of Ramsey employees must be a regular employee scheduled to work at least 30 hours per week. The City provides a contribution to health insurance and basic life insurance for full-time employees as approved by the City Council annually.

In accordance with federal health care reform laws and regulations, the City shall offer health insurance benefits to eligible employees and their dependents that work on average or are expected to work 30 or more hours per week or the equivalent of 130 hours or more per month. In order to comply with Health Care Reform law while avoiding penalties, part-time employees will be scheduled with business needs and in manner which ensures positions retain part-time status under which intended

4.2 Long Term Disability (“LTD”)

Mandatory LTD - Long term disability is a mandatory, employee-paid benefit provided to sworn police personnel and other full-time, non-union public safety employees.

Voluntary LTD - Long term disability is available to other employee groups as a voluntary employee-paid benefit.

The terms of the long term disability coverage, including the formula used to calculate the benefit and the waiting period before an employee may receive long term disability benefits will be established by the City.

4.3 Public Employment Retirement Association (“PERA”)

Almost all city employees in the State of Minnesota are covered by a public pension system known as the PERA. Both the City and employees contribute to PERA. For specific information regarding annual contribution rates, contact Human Resources. Vesting time varies depending on membership eligibility date and the pension is portable among public employers throughout the state. Being vested means qualifying for benefits at the minimum allowable age.

In normal situations, employees and employers both contribute a percentage of the employee’s eligible gross salary to PERA. However, Minnesota law provides that some income received by an employee are not eligible for PERA contributions. Employees should contact Human Resources with specific questions regarding PERA contributions.

4.4 Deferred Compensation

All employees eligible to enroll in PERA are also eligible to place a portion of their earnings in a pre-tax investment program. Deferred compensation plans are available through ICMA Retirement Corporation and Minnesota State Deferred Compensation. Please contact Human Resources

regarding maximum annual contribution amounts and for any other specific information regarding deferred compensation plans.

4.5 Flexible Spending Account

Employees can establish flexible spending accounts and have pre-tax deductions made from their payroll checks to pay for eligible childcare and eligible medical expenses. The law limits the maximum contributions that employees can make to their flexible spending account and the specific expenses that can be paid out of such accounts. Employees should contact Human Resources for additional details.

4.6 Retiree Benefits

Minnesota law provides for continuation of health and dental coverage to certain former employees who are receiving a disability benefit or an annuity from PERA, or who have met PERA age and service requirements. Former employees are responsible for paying the entire premium. Failure to do so will result in termination of coverage. Employees should contact Human Resources for additional details.

4.7 COBRA

Employees participating in the City's group health insurance plan who terminate employment with the City or experience another event which triggers their legal entitlement to insurance continuation will receive a notice of their right to elect continued insurance coverage consistent with state and federal law, including, but not limited to, the Consolidated Budget Omnibus Reconciliation Act of 1985 ("COBRA") (as amended). The notice will be provided in accordance with such laws and employees must comply with those laws if they wish to continue coverage after separating from the City's employment, including, but not limited to, paying the entire premium for the duration of the continuation coverage. Employees should contact Human Resources for additional details.

4.8 Employee Assistance Program

The City offers an employee assistance program (EAP) at no cost to assist employees and their families with a variety of services from mental health and substance abuse counseling to child care resources. The EAP will provide confidential counseling services by highly trained clinicians or suggest other professional resources that may be useful to employees and their families.

SECTION 5 CLASSIFICATION AND COMPENSATION

5.1 General

Employees of the City shall be compensated according to the schedule established by the City Council. Any wage, salary, or other monetary benefit so established is the total remuneration for employment which may be allowed for the conduct of official business, but shall not be considered as reimbursement for official travel or other expenses. Unless approved by the City Administrator, no employee shall receive pay from the city in addition to the salary authorized for the position or positions to which the employee has been appointed, or for hours beyond the normal work week without prior approval by the City Administrator or designee.

Non-exempt employees who work for a period less than the regularly scheduled work-week will earn wages based on the actual number of hours worked. Regular part-time employees are eligible to earn vacation and sick leave in proportion to that earned by regular full-time employees based on the number of hours worked. Holidays are earned in proportion to those earned by regular full-time employees and are based on work hours budgeted on January 1. Vacation and sick leave, and holidays count toward total budgeted work hours for the year. Temporary employees are not eligible for vacation or sick leave, holiday pay, or health or life insurance.

Employees shall be paid biweekly via mandatory direct deposit. When a pay day falls on a holiday, employees shall receive their pay on the preceding work day.

No employee shall be permitted to receive from any third party payment for services and labor performed while such employee is working regular hours or while working additional overtime hours for the City, unless approved in advance by the City Administrator and subject to a written agreement with the third party--such as with Anoka County.

5.2 Classification Plan / Position Descriptions

The City will establish and maintain a position classification plan for all positions in accordance with federal and state laws. The Human Resources Manager, under the direction of the City Administrator, and in conjunction with Department Heads, shall be responsible for establishing, periodically revising, and maintaining current position descriptions. The position description shall state the essential duties, responsibilities and qualification requirements which distinguish a given position from other positions. The position description shall describe the typical types of work which may be assigned to a particular position but shall not be construed to restrict the assignment of other duties related to the position. Supervisors may direct their subordinates to perform tasks not expressly identified in the position description, as they see fit.

Each position description shall contain:

- a. Essential duties and responsibilities of the position.
- b. Examples of work which are illustrative of the duties of the position.
- c. Descriptions of the level of knowledge, skills and abilities necessary to perform the essential duties and responsibilities.
- d. Minimum requirements of the position which will include the desired level of education, experience, education and training for recruitment into the position.
- e. Working conditions and physical demands of the position.

Purpose

The purpose of the classification plan / position description is to:

- a. Establish reasonable compensation relationships between job classifications.
- b. Establish qualification standards for recruitment and testing purposes.
- c. Provide the appointing authority with means for analyzing work distribution, areas of responsibility, lines of authority, and other relationships between positions.
- d. Assist the appointing authority in determining budget requirements.
- e. Provide the basis for developing standards of work performance.
- f. Indicate training needs.
- g. Provide uniform titles to positions.

Class

A class shall be comprised of one or more positions that are substantially similar with respect to the type, difficulty, and responsibility of work performed.

Administration of the Classification Plan / Position Descriptions

The classification plan shall be established and maintained through recommendation of the Department Head and the Human Resources Manager to the City Administrator. The City Administrator may establish a new class, create a new position within a class or reclassify a position upon approval by the City Council.

When a new position is proposed by a Department Head or the Human Resources Manager, a request for the position along with a description of the duties and responsibilities of the position shall be submitted to the City Administrator. The position shall be analyzed and evaluated based on the duties and responsibilities without regard to the personal characteristics, abilities or qualifications of the incumbent. The final approval of the classification shall be by the City Council.

5.3 Reclassification

When the duties and responsibilities of a position change, the Department Head may initiate a request for a change in classification. This request must be submitted in writing to the Human Resources Manager accompanied by a proposed updated position description prepared by the Department Head. The Human Resources Manager shall submit the request to the City Administrator for review and approval or denial. If the City Administrator denies a request for reclassification, no similar request may be submitted for one year. The Human Resources Manager, acting under the direction of the City Administrator, may also review the classification of existing positions from time-to-time, regardless of whether a Department Head proposed reclassification within the preceding year.

Factors that should be considered that could lead to conducting an analysis of existing positions include, but are not limited to, the following:

- a. Change in the existing organizational or reporting relationship.
- b. Significant additions, reductions or changes in the essential functions for which the position is accountable which affect the level of skill, knowledge, responsibility or working conditions of the position.
- c. Change in the supervisory functions assigned to the position.
- d. Change in the qualifications required of the position.

5.4 Compensation Plan

The compensating plan shall be reviewed annually by the City Administrator and presented to the City Council as part of the annual budget process. The City Administrator may modify any or all of the pay ranges or grades as set forth in the plan at any time, at his or her discretion, subject to approval by the City Council. The City Administrator may also set effective dates for the pay plan. All pay ranges shall be construed as policy declarations and not binding, permanent contractual obligations between the City and its employees. Any amendment to the pay plan shall be based on changes in the responsibility or the duties of the position, recruiting experience, rates of pay and benefits in the public and private sector, the City's financial status, general economic conditions, federal or state law, including the Minnesota Pay Equity law, or other pertinent factors warranting such action.

In addition, from time to time the position and pay classification plan may be amended by City Council resolution upon receipt of a recommendation from the City Administrator. In making such recommendations, the City Administrator shall give appropriate consideration to the following factors:

- a. Maintenance of equitable relationship between classes, based on their relative duties and responsibilities.
- b. Indicators, from the appropriate labor market, for comparable work under similar conditions.
- c. Current recruitment and retention experience.
- d. Comparable worth for all positions within the organization.
- e. Ability of the city of Ramsey to fund the position.

Content of Pay Plan

The pay plan presented to the City Council for its approval shall consist of the minimum and maximum rate of pay for each position in the organization. Each position shall be assigned to a pay class and all positions in the pay class shall be compensated according to the established pay range. A pay range will be assigned to each class according to the responsibilities of the position, the duties and pay for other positions, prevailing rates of pay for comparable positions in public and private employment in the area, fringe benefits received by employees, the financial policy of the City, federal and state statutes and other pertinent economic factors.

Pay Plan Administration

The City Administrator shall be responsible for administering the Pay Plan according to this section.

Beginning Salary Rate – The beginning rate for a new employee will be the minimum rate in the established class for his or her position classification. The Employer, at its sole discretion, may approve a pay rate above the minimum rate to:

- a. Mitigate recruiting obstacles.
- b. Hire a person with superior qualifications.
- c. Correct salary inequities.
- d. Give credit for prior service.

Method of Progression

After appointment or promotion and pending satisfactory performance, an employee shall be eligible for advancement through his/her respective salary range as specified in the collective bargaining agreement or as authorized by the City Council.

Market Adjustment Pay–

Occasionally positions within the City may fall behind in pay with regard to the market value. When this becomes apparent, the Human Resources Manager may, in his or her sole discretion, make a recommendation for the appropriate salary adjustment to the City Administrator. Upon approval by the City Administrator, the employee in said position will receive a salary range adjustment. The employee will retain her or his original anniversary date for the purposes of step increases and performance evaluations. Any increases that result in more than a five percent increase shall be submitted to the City Council for approval or denial.

Extra Duty Pay / Interim Pay

The City Administrator shall have the authority to grant short-term extra duty pay. Any extra duties that qualify for extra duty pay would be responsibilities that fall well outside of the respective employee's job description and would have a defined end date, but would not exceed six months. Typically, extra duty pay would be tied to a special project or event. At the City's discretion, extra duty pay may be paid via a payroll stipend. Interim pay would include, for example, filling in for a vacancy, FMLA or leave absence. Interim pay shall not exceed 10% over the current base salary. The City Administrator's approval of extra duty pay or interim pay is subject to available funding within the budget.

Overtime Compensation for Exempt Employees

Federal law allows exempt City employees working two or more positions with the City to agree, in advance, to receive overtime compensation for the secondary position, subject to certain restrictions and limitations. Exempt employees holding two or more positions within the City should consult with Human Resources regarding the possibility of overtime. No overtime will be paid pursuant to this provision without prior written approval from Human Resources.

Overtime pursuant to this section will be paid for hours worked in a secondary position only if the employee worked at least 40 hours at the primary position during the normal workweek. Sick and vacation leave, holidays and compensatory time off count as time worked as per the Personnel Policy.

5.4 Payroll Deductions

Certain deductions from earnings, such as federal and state income taxes and social security taxes, are required by law. These deductions will be identified on the direct deposit vouchers. The

amount of these required deductions may change since they are affected by changes in the amount earned, and in the case of income tax, they are affected by changes in the number of dependents claimed. Monies earned during a two (2) week pay period, cannot be divided into two payroll checks. Employees should contact Human Resources with any specific questions.

5.5 Meal Periods and Breaks

When working under conditions where a break period is practicable, all hourly employees are entitled to two (2) 15 minute breaks with pay per eight (8) hour shift at times designated by the supervisor. Most employees also receive a thirty (30) minute unpaid meal period during each eight hour work day. With the exception of officers, employees are not compensated during the meal period.

5.6 Overtime Compensation/Compensatory Time Off

Non-exempt, non-union employees will be paid overtime compensation for all hours worked in excess of forty (40) hours per work week at a rate of one and one-half times the regular rate of pay. Paid holidays, vacation leave, compensatory time off, and sick leave are considered time worked for the purposes of calculating overtime hours.

Overtime pay will not be paid for time not worked. Exempt employees, as defined by the Fair Labor Standards Act, are not entitled to overtime pay.

Non-exempt, non-union employees will be allowed to take compensatory time off in lieu of receiving over time compensation. Compensatory time off is computed at a rate of one and one-half times the hours worked in excess of the forty (40) hour work week. Accrued compensatory time off shall not exceed 120 hours at any time. Once an employee has accrued 120 hours of compensatory time off, compensation for additional hours worked must be paid in cash, rather than accrued as compensatory time off.

The City reserves the right to payout any compensatory time off hours in excess of 80 hours, as it deems necessary.

The City allows employees to cash out up to a maximum 40 hours of compensatory time off annually; to be paid out up to twice annually, January 1 through January 15, and November 1 through November 15 of each year, to total a maximum payout of 40 hours of compensatory time off. Note: upon terminating employment with the City, all compensatory time off will be paid out at 100% of the accrued balance.

For the purposes of calculating overtime, an employee using paid holidays, vacation leave, sick leave, or compensatory time off is considered to be working.

Accrued compensatory time off may be used with prior approval from the employee's Department Head. Upon an employee's separation from the City, there will be a pay-out of accrued and unused compensatory time off at the then current hourly rate of pay.

Exempt employees, as defined by the Fair Labor Standards Act, are not entitled to compensatory time off.

For the purposes of computing overtime compensation and compensatory time, overtime hours worked shall not be pyramided, compounded, or paid twice for the same hours worked.

5.7 Severance Pay

Severance pay is available to employees who have at least five (5) years of continuous service with the City and resign “in good standing,” as that phrase is used in Section 4.11 of this policy. Employees who are discharged are not “in good standing” and may not receive severance pay pursuant to this policy.

Qualifying employees who resign “in good standing” shall receive a lump sum payment upon termination of employment with the city of Ramsey based on thirty-three (33) percent of employee’s unused, accumulated sick leave after five (5) years of continuous employment. After fifteen (15) years of continuous employment, the employee will instead receive thirty-five (35) percent of said employee’s unused, accumulated sick leave. After twenty (20) years of continuous employment, the employee will instead receive thirty-seven (37) percent of unused accumulated sick leave. After twenty-five (25) years of continuous employment, the employee will instead receive forty (40) percent of said employee’s unused, accumulated sick leave.

Receipt of severance pay terminates all seniority rights and ends all city of Ramsey liability with regard to other benefits, except as otherwise provided by law and any applicable collective bargaining agreement.

SECTION 6 LEAVE

6.1 Vacation Leave

The city of Ramsey provides eligible employees vacation benefits to promote rest and relaxation away from work. Requests for scheduled vacation should be made to the Supervisor/Department Head by January 31 of each year. When considering whether to grant conflicting vacation requests submitted during January of each year, seniority by department will prevail; thereafter, vacation leave shall be initiated on forms submitted to the Department Head at least two weeks prior to requested vacation time off. Exceptions to this policy are granted on a very limited basis. To assure efficient functioning of the City, it is necessary to limit the number of employees on vacation at the same time.

An employee's banked vacation leave may not exceed two times the yearly accrual at any point in time, unless approved by the City Administrator. Once an employee has banked the maximum amount of vacation hours allowed, all additional hours accrued are forfeited. Employees are responsible for monitoring their own balances. Additional pay in lieu of vacation is not permitted.

For the purposes of accumulating additional vacation leave, an employee using earned vacation leave, sick leave, compensatory time off, or paid holidays is considered to be working.

At the discretion of the Department Head, an employee may use accrued vacation leave during the probationary period. An employee who separates from the City "in good standing," as that term is defined in Section 4.11 of this policy, shall be compensated for vacation accrued and unused through the last date of employment.

New employees will begin employment with a vacation balance of zero, followed by vacation accruals based on one of the following vacation accrual schedules. However, at the discretion of City Administrator, a one-time vacation credit may be negotiated and in order to:

- a. Mitigate recruiting obstacles.
- b. Hire a person with superior qualifications.
- c. Give credit for prior service.

The bi-weekly accrual rate will not be accelerated due to any upfront vacation credits.

Vacation Accrual Schedules

Department Head Vacation Accrual Schedule		
Effective Date	Bi-weekly Accrual Rate	Vacation Days/Year
Start date	4.62 hours/pay period	15 days
6 th Anniversary	5.54 hours/pay period	18 days
7 th Anniversary	6.15 hours/pay period	20 days
12 th Anniversary	6.46 hours/pay period	21 days
16 th Anniversary	6.77 hours/pay period	22 days
17 th Anniversary	7.08 hours/pay period	23 days
18 th Anniversary	7.38 hours/pay period	24 days
19 th Anniversary	7.69 hours/pay period	25 days

Full-Time, Management Vacation Accrual Schedule		
Effective Date	Bi-weekly Accrual Rate	Vacation Days/Year
Start date	4.62 hours/pay period	15 days
6 th Anniversary	5.54 hours/pay period	18 days
8 th Anniversary	5.85 hours/pay period	19 days
10 th Anniversary	6.15 hours/pay period	20 days
12 th Anniversary	6.46 hours/pay period	21 days
16 th Anniversary	6.77 hours/pay period	22 days
17 th Anniversary	7.08 hours/pay period	23 days
18 th Anniversary	7.38 hours/pay period	24 days
19 th Anniversary	7.69 hours/pay period	25 days

Full-Time, Non-Union Vacation Accrual Schedule		
Effective Date	Bi-weekly Accrual Rate	Vacation Days/Year
Start date	3.08 hours/pay period	10 days
6 th Anniversary	4.62 hours/pay period	15 days
12 th Anniversary	6.15 hours/pay period	20 days
16 th Anniversary	6.46 hours/pay period	21 days
17 th Anniversary	6.77 hours/pay period	22 days
18 th Anniversary	7.08 hours/pay period	23 days
19 th Anniversary	7.38 hours/pay period	24 days
20 th Anniversary	7.69 hours/pay period	25 days

Regular part-time employees are eligible to earn vacation leave in proportion to that earned by regular full-time employees based on the number of hours worked. Vacation leave will count toward total budgeted work hours for the year.

6.2 Sick Leave

Sick leave may be authorized when an employee is unable to perform work duties due to illness, disability, the necessity for medical, dental, or chiropractic care, childbirth, or exposure to contagious disease where such exposure may endanger the health of others with whom the employee would come in contact in the course of performing work duties. Sick leave may also be authorized for any purpose authorized by law, including, but not limited to, Minnesota Statutes, section 181.9413 (as amended). For additional information as to when sick leave may be utilized, employees should contact Human Resources

To be eligible for sick leave with pay, an employee shall:

- a. Report as soon as possible to the employee's immediate supervisor the need to be absent and identify if the absence is due to the employee's illness or the employee's immediate family, as listed above;
- b. Keep the employee's immediate supervisor informed of such employee's need for continued absence;
- c. For any absence that exceeds three days, upon request by the City Administrator, submit a medical certificate before the employee will be allowed to return to work.

Using or claiming sick leave for a purpose not authorized may be cause for disciplinary action. For the purpose of accumulating additional sick leave, an employee using earned vacation leave, sick leave, compensatory time off, or paid holidays is considered to be working. At the discretion of the Department Head, an employee may use accrued sick leave during the probationary period. After the end of the probationary period, an employee is entitled to use sick leave accrued from the start of the probationary period.

Sick Leave Accrual

Every probationary and regular employee is entitled to earn sick leave with pay at the rate of 1 day (based on an 8-hour day) for each calendar month of full-time service or major fraction thereof. Sick leave may be accrued to 120 days (960 hours); unused sick leave in excess of 120 days (960 hours) at the end of a calendar year (December 31st) shall be converted to vacation at a rate of one hour of vacation for each two hours of sick leave, subject to the maximum amount of accrued vacation leave provided in this policy.

Regular part-time employees are eligible to earn sick leave in proportion to that earned by regular full-time employees based on the number of hours worked. Sick leave will count toward total budgeted work hours for the year.

Sick Leave for Wellness (Non-union and AFSCME Employees Only)

Use of Sick Leave for Wellness Activities: Employees who have been employed with the city of Ramsey for at least five (5) years and who have accrued a minimum sick leave balance of 300 hours will be allowed to use up to 24 hours of sick leave annually for cash payment for approved wellness activities, described below.

Sick leave used for wellness activities will be paid according to the City's sick leave severance schedule based on the employee's years of service and wage at the time the request for payment is made. The City's severance schedule at the time of this writing is as follows: 33% after five years of service; 35% after 15 years of service; 37% after 20 years of service; and 40% after 25 years of service. Once the benefit is received it is non-reversible and the employee's sick leave accrual will be reduced by the number of hours claimed and/or approved.

Income Taxes and Effect to Sick Leave Accruals

Payments other than to deferred compensation will be taxable income to the employee and subject to all applicable taxation requirements.

Required Documentation

Requests for using sick leave for wellness activities will be accepted twice annually, from June 1-15 and December 1-15. Such requests will be processed in July and December, respectively, unless otherwise indicated. An activity for which payment is requested must have occurred in the same calendar year in which the request for payment is made. All claims shall be submitted to Human Resources via a Sick Leave for Wellness Request Form accompanied by proper documentation for each activity.

Approved Medical and Dental Expenses

Sick leave may be used to pay employees for the employee's medical and dental expenses not covered by the City's insurance plans. Accumulated sick leave used for this purpose will be paid according to the City's sick leave severance schedule based on the employee's years of service and wage at the time the request for payment is made. To receive the payment, the employee will fill out a Sick Leave for Wellness Request Form and submit proof of the expense to Human Resources.

Approved Wellness-Related Activities

- a. Individual employee memberships in approved health clubs and/or a sum equal to an individual membership for those employees holding family memberships which include the employee. An approved health club would be one that provides facilities for aerobic and strength training activities.
- b. Programs designed to improve health such as classes on weight loss, smoking cessation or stress management are also allowed. This includes jazzercise, exercise classes, learning to eat, and weight watchers.
- c. Regular (meaning at least once a week) fitness activities resulting in a moderate to high aerobic benefit and their fees and memberships will also be eligible for payment. This includes activities such as singles tennis, racquetball, handball, court fees associated with these sports, basketball, exercise classes, hockey, soccer, martial arts training, skating, cross country skiing and gymnastics.
- d. Fitness/exercise equipment (e.g., stationary bikes, treadmill, stair stepper, rowing machine, ice/inline skates, skis)

The following activities are not eligible for payment:

- a. Activities and equipment with a relatively low aerobic benefit, such as bowling, golf, dancing, horseback riding, archery, and baseball/softball. Also excluded are whirlpools, saunas, and massage therapy.
- b. Any clothing costs, competitive registration fees or costs for food will not qualify for payment.
- c. Membership fees for clubs that are primarily social in nature (i.e., country clubs, golf/tennis clubs).
- d. Accessory items (e.g., book holders, water bottles/holders, bike racks), assembly charges, shipping fees and maintenance contracts.

Employees are advised to have a physical examination by their physician if they are beginning a new program of physical activity. Employee may not participate in any Sick Leave for Wellness eligible program on City time. Sports, activities and equipment not listed will be evaluated on a case by case basis by Human Resources.

Approved Deferred Compensation Contributions

Eligible employees will be allowed to convert accumulated sick leave to deferred compensation deposits. Deposits in combination with all other payments to the deferred compensation accounts are subject to maximum deferral regulations. Accumulated sick leave used for deferred compensation contributions will be paid according to the City's sick leave severance schedule based on the employee's years of service and wage at the time that the contribution to deferred compensation is requested. Requests for contributions under this section must be submitted to Human Resources by December 15. Contributions will be made to deferred compensation plans via payroll deduction in December pre-tax. Requests for contributions under this section must be submitted to Human Resources by December 31. Contributions will be made to deferred compensation plans via payroll deduction in January of the following year and will not be taxable.

Employees who are in the process of terminating employment are not eligible for payments under this program. All requests for payment under this program must be approved by Human Resources.

6.3 Holidays

The city of Ramsey recognizes twelve (12) holidays for non-union employees. Regular employees are eligible for holiday pay provided they work the day preceding, and the day following, the holiday, (unless the day(s) off were previously approved by the supervisor). Regular employees who are scheduled to work the holiday will be given another day off with pay. Paid holidays include:

- | | | |
|----|-------------------|-------------------------------------|
| 1. | New Year's Day | January 1 st |
| 2. | Martin L King Day | 3 rd Monday in January |
| 3. | President's Day | 3 rd Monday in February |
| 4. | Memorial Day | Last Monday in May |
| 5. | Independence Day | July 4 th |
| 6. | Labor Day | 1 st Monday in September |

- | | | |
|-----|-------------------------------|--------------------------------------|
| 7. | Veteran's Day | November 11 th |
| 8. | Thanksgiving Day | 4 th Thursday in November |
| 9. | Friday after Thanksgiving Day | (Non-union and AFSCME only) |
| 10. | Christmas Eve | December 24 th |
| 11. | Christmas Day | December 25 th |
| 12. | Eight Hour Floating Holiday | To be used Jan. 1 to Dec. 31 |

All employees in full-time regular positions are entitled to time off with full pay on holidays. The City shall be closed for business on each such holiday, but employees may be required to work on paid holidays when the nature of their duties or other conditions requires them to do so.

Regular part-time employees are eligible to earn paid holidays in proportion to that earned by regular full-time employees based on work hours budgeted on January 1. Paid holidays will count toward total budgeted work hours for the year.

If an approved holiday falls on a day a part-time employee is not scheduled to work, the employee must take the paid holiday leave during the same pay period in which the holiday occurred.

Employees may be required to work on paid holidays when the nature of their duties or other conditions require them to do so. A non-exempt, non-union employee required to work on a holiday shall receive their full pay for the holiday, as well as a minimum of 2-hours pay at a rate of 1-1/2 times the employee's base hourly pay rate for the time worked on such holiday. All holidays specified will be paid in dollars or as earned compensatory time off.

When New Year's Day, Independence Day, Christmas Eve or Christmas Day falls on Sunday, the following Monday is considered the paid holiday and if any such day falls on Saturday, the preceding Friday is considered the paid holiday. Each holiday commences at the beginning of the first shift on the day on which the holiday occurs and continues for 24 hours thereafter. Eligible employees shall receive pay for official holidays at their normal rate of pay if they are at work or on a leave of absence with pay the last regular shift to which they would have been assigned prior to the holiday and the first regular shift to which they would have been assigned following the holiday.

New employees hired after December 15th are not eligible for the floating holiday during the calendar year in which they were hired. Floating holidays may not be carried over.

6.4 Family and Medical Leave

Eligible employees may be entitled to take unpaid leave pursuant to the Family and Medical Leave Act ("FMLA") for the purposes described in 29 U.S.C. § 2612 (as amended). All such leave, including the responsibilities of the City and its employees related to such leave, is subject to the conditions prescribed in the FMLA and the Department of Labor's regulations implementing the FMLA.

For additional information regarding FMLA leave, including the circumstances in which such leave may be taken, employees should consult the posted notices. In addition, as permitted by the FMLA, the City places the following restrictions on eligible employees' use of FMLA leave:

The City has designated a “rolling” 12 month period for purposes of determining employees’ entitlement to FMLA leave. The “rolling” 12 month period begins on the date the employee uses “any” FMLA leave.

An eligible husband and wife couple employed by the City are permitted to take a combined total of 12 work weeks of FMLA leave in a single 12-month period if the FMLA leave is: (1) due to the birth of a son or daughter of the employees, (2) due the placement of a son or daughter with the employees for adoption or foster care, or (3) in order to care for a parent of the eligible employee.

Employees may request leave under this policy based on: (1) their own serious health condition; (2) to care for a parent, spouse, or child’s serious health condition; or (3) military caregiver leave, or, (4) or any another eligible circumstances contingent upon the FMLA. Employees are required to submit a completed medical certification that complies with the requirements of the FMLA. Medical certification forms are available from Human Resources. Employees who request leave under this policy are required to submit medical certificate outlining the dates on which treatment is expected and the expected duration. The City reserves the right to request a second opinion, at the expense of the City, to the extent permitted by the FMLA. If the results of the employee’s certification differs from the results of the City’s certification, the City may obtain a third opinion at the City’s expense. The City also reserves the right to require periodic recertification, to the extent allowed by the FMLA and to contact the certifying medical provider to authenticate or clarify the medical certification in lieu of seeking a second opinion.

Separate certification may also be required regarding the nature of the family member’s military service and/or the existence of a qualifying exigency, if leave is requested for that purpose.

Except in emergency situations, the employee is required to provide written notice of the need to take leave to the employee’s supervisor not less than 30 days before the date the leave is to begin. If the leave is to begin in less than 30 days, the employee shall provide such written notice as soon as practicable.

Employees are required to use all accrued sick leave, vacation leave, and any other accrued paid leave, except a combined total of forty hours of accrued paid leave and/or compensatory time off, concurrently with leave provided under the FMLA. The combined paid and unpaid leave cannot exceed the applicable 12 week or 26 week maximum FMLA leave time. FMLA leave may run concurrently with a worker’s compensation absence if the on-the-job injury or illness also qualifies as a serious health condition under the FMLA.

Subject to the terms, conditions, and limitations of applicable plans, eligible employees are entitled under the FMLA to the same health insurance benefits provided by the City while on FMLA leave to the same extent as if the employee were not on FMLA leave. Employees who contribute toward their health care coverage must continue to make that contribution while on leave, either through payroll deduction (if using paid leave) or by personal check (if using unpaid leave). If the employee fails to return to work after taking family or medical leave, the City may recover the premiums paid by the City for group health and life insurance unless the serious health condition of the spouse, child, parent or employee continues or for other circumstances beyond the control of the employee.

Vacation, sick, and holiday leave will not be earned during a period of unpaid FMLA leave. FMLA leave - whether paid or unpaid – will not constitute a break in service for purposes of computing years of service.

Employees generally have the right to return to an equivalent position with equivalent benefits, pay and other terms and conditions of employment upon returning to work after a period of FMLA leave. However, employees who fail return to work following, or require additional time away from work after exhausting, their FMLA leave in the designated "12 month period" no longer have FMLA protections of leave or job restoration. In addition, an employee who fails to return to work at the end of FMLA leave, in most cases, will be considered to have voluntarily resigned his/her position with the City. Employees who do not return to work at the end of their FMLA leave may be terminated.

The City requires a medical certificate attesting to the employee's fitness for duty prior to the employee being allowed to return to work. The fitness for duty report must be based on the particular health condition(s) for which the leave was approved and must address whether the employee can perform the essential functions of the job. The Human Resources Manager may consult with a physician or other expert to determine reasonable accommodations for any employee who is a "qualified disabled" employee under the Americans with Disabilities Act. If a fitness for duty certification is required, the City may deny reinstatement until it is provided.

Records on family and medical leave will be kept along with normal personnel records except that any medical record will be maintained separately in accordance with applicable laws.

The FMLA is a complex area of law with detailed federal regulation that is impacted by other related issues. Questions should be directed to Human Resources.

6.5 *Extended Medical Leave*

When medically necessary, and upon receipt of a medical certificate from an employee's treating physician, the City Administrator may approve a request for a medical leave extension of up to three months due to the employee's serious medical condition or to care for a spouse, parent or child who has suffered a serious medical condition.

Before using unpaid leave under this section, the employee must use all paid leave except a combined total of forty hours of accrued vacation leave, sick leave, holiday pay, and/or compensatory time off.

The medical certificate described herein is required before sick leave will be authorized.

Health and life insurance benefits will continue to be paid by the City for an employee who is on extended medical leave at the same level as if the employee were working. Employees who contribute toward their health care coverage must continue to make that contribution while on leave, either through payroll deduction (if using paid leave) or by personal check (if using unpaid leave). If the employee fails to return to work after taking extended medical leave, the City may recover the premiums paid by the City for group health and life insurance unless the serious health condition of the spouse, child, parent or employee continues or for other circumstances beyond the control of the employee.

Vacation, sick, and paid holiday leave will not be earned during a period of unpaid extended medical leave. Use of approved extended medical leave will not constitute a break in service for purposes of computing years of service. The city of Ramsey does not guarantee job restoration after a period of extended medical leave.

The City requires a medical certificate attesting to the employee's fitness for duty prior to the employee being allowed to return to work. The fitness for duty report must be based on the particular health condition(s) for which the leave was approved and must address whether the employee can perform the essential functions of the job. The Human Resources Manager may consult with a physician or other expert to determine reasonable accommodations for any employee who is a "qualified disabled" employee under the Americans with Disabilities Act. If a fitness for duty certification is required, the City may deny reinstatement until it is provided.

6.6 Bone Marrow Donation Leave

State law provides for paid leaves of absence to an employee who works an average of at least 20 hours per week and seeks to undergo a medical procedure to donate bone marrow. The length of the leave shall not exceed 40 work hours, unless agreed to by the City. Bone Marrow Leave is not chargeable against accrued vacation or sick leave or compensatory time off. The City may require certification from the treating physician regarding the purpose and length of the leave requested by the employee.

6.7 Temporary Light Duty

Consistent with public service needs, the City may assign light duty to employees who are temporarily unable to fully perform all work duties. The City reserves the sole right to determine, on a case-by-case basis, whether light duty will be assigned and, if assigned, what duties the employee will be expected to perform and the duration of the assignment, which cannot exceed two to four weeks. The City does not guarantee that any light duty will be available, and is under no obligation to create a new position to accommodate any employee's inability to perform the essential functions of their job.

The procedure for applying for a light duty assignment will be as follows:

- A. When an employee is unable to provide full performance of all assigned work duties, the employee may request light duty by submitting a written request to the Department Head. The request shall be accompanied by the treating physician's medical certification indicating diagnosis, current treatment, and the extent and duration of any work restrictions.
- B. The City may require an independent evaluation conducted by a physician selected by the City to verify the diagnosis, current treatment, work restrictions and expected length of disability.
- C. Determinations regarding light duty will be made on a department-by-department, case-by-case basis. The Department Head, in consultation with the Human Resources Manager, will consider such factors as public service needs and budgetary consideration, the need for work which may be assigned as light duty, the employee's capability of performing the work, the number of employees not available for work due to injury or illness, and other

relevant factors, as determined by the Human Resources Manager's sole discretion. The City does not guarantee that any light duty will be available, and is under no obligation to create a new position to accommodate any employee's inability to perform the essential functions of their job.

- D. The City will determine what job duties the employee will perform. These duties may include those currently assigned to the employee's job classification or any other duties the City considers to be appropriate. Duration of light duty will be determined at the sole discretion of the City, but will not exceed two to four weeks.
- E. If the treating physician requires a continuation of light duty beyond the initial two weeks, the employee must submit the treating physician's documentation for the Human Resources Manager's review in order to determine if the City can grant an additional two weeks of light duty. The City, at its sole discretion, reserves the right to terminate a light duty assignment at any time based upon, but not limited to, the factors set forth in sub-item C above.

6.8 Military Leave

State and federal laws provide for and regulate military leave for employees who are called to military service, whether in the Reserves or full-time service. Leave from employment to participate in military duty is addressed in federal law in the Uniformed Services Employment & Re-employment Rights Act (USERRA). Public employees in Minnesota engaged in military service have additional benefits under Minnesota Statutes. Every city of Ramsey employee, whether in the Reserves or full-time service, will be afforded the benefits entitled to them under federal and state law. Employees should contact Human Resources for additional details.

6.9 Parenting Leave

Parenting Leave, as provided for in Minnesota Statutes, grants qualifying employees unpaid leave of up to twelve (12) weeks for: (1) a biological or adoptive parent in conjunction with the birth or adoption of a child; or (2) a female employee for prenatal care, or incapacity due to pregnancy, childbirth, or a related health condition. Parental Leave is considered to be taken simultaneously with FMLA leave. If leave is taken due to the birth or adoption of a child, the leave must begin within twelve (12) months of the birth or adoption, unless the child remains in the hospital after the mother has been discharged, in which case the leave must begin within twelve (12) months after the child leaves the hospital.

6.10 School Conference and Activities Leave

Any qualifying employee may take leave of up to 16 hours during any 12-month period to attend school-related activities related to the employee's child attending school, provided the school-related activities cannot be scheduled during non-work hours.

When the leave cannot be scheduled during non-work hours and the need for the leave is foreseeable, the employee must provide reasonable prior notice of the leave and make a reasonable effort to schedule the leave so as not to unduly disrupt the operations of the employer. Employees may use accrued vacation leave or compensatory time off concurrently with leave granted pursuant to this section.

6.11 Jury or Witness Duty

Any employee who is required to serve as a juror or who is under subpoena as a witness in court for job related purposes, shall be granted a leave of absence with pay while serving in such capacity. An employee cannot receive more than the employee's normal take-home pay as a result of any employer pay supplemented to Jury Duty pay. Jury duty pay excluding transportation reimbursement, must be remitted to the City within 30 days after receipt of payment from judicial agency. When employees are excused from jury duty or serving as a witness during their regular working hours, they are expected to return to work if practicable.

6.12 Funeral Leave

Employees are allowed funeral leave up to 24 hours twice annually per occurrence (a maximum of 48 hours during any calendar year) for a death in the immediate family. Funeral leave is not chargeable against any accrued vacation leave, sick leave, or compensatory time off. All funeral leave for a particular occurrence must be taken within five (5) calendar days from start to finish. Additional funeral leave may be taken with prior approval from the employee's supervisor. Such additional leave will be deducted from the employee's sick leave (up to three (3) consecutive days), vacation leave or compensatory time off as the employee may choose and have available.

Immediate family, for the purposes of this section, shall be defined as spouse, parent, stepparent, children, step-children, brother, sister, grandparents, grandchildren or a like member of employee's spouse's family.

SECTION 7 CONDUCT

7.1 Code of Conduct

Policy Statement

It is the policy of the city of Ramsey to maintain a respectful work and public service environment free from violence, discrimination, and offensive or degrading remarks or conduct. Preserving a respectful environment in which to work is the shared responsibility of both management and employees. Inappropriate conduct or communication can interfere with an individual's employment or use of public services, or create an intimidating, hostile or offensive work environment. Any employee found to have acted in violation of this policy shall be subject to appropriate disciplinary action, which may include dismissal from employment.

Scope

This policy governs the conduct of all City employees, including: elected officials; union, non-union, supervisory, non-supervisory, managerial, full-time, part-time and temporary employees; and members of City boards and commissions.

Definitions of Prohibited Behaviors

Violent behavior includes the use or threat of physical force, harassment, or intimidation, or abuse of power or authority when the impact is to control others by causing pain, fear or hurt.

Discriminatory behavior includes inappropriate remarks about or conduct related to an employee's race, color, creed, religion, national origin, disability, sex, marital status, familial status, age, sexual orientation, or status with regard to public assistance.

Offensive behavior may include, but is not limited to, such work-related actions as rudeness, exclusionary behavior, creating or displaying graphics depicting co-workers or customers inappropriately, angry outbursts, inappropriate joking, vulgar obscenities, name calling, disrespectful language, or the intentional filing of an unfounded complaint under this policy.

Policies

1) Expected Conduct of City Employees in General

Employees of the City shall conduct themselves at all times while on duty or on the employer's premises, in such a manner as to reflect most favorably on the City. Conduct unbecoming a City employee shall include any conduct that tends to bring the City into disrepute or reflects discredit on the person as an employee of the City, or that which tends to impair the functioning of an employee, a department, or the City.

Loyalty to the City and to associates is important to staff morale and efficiency. Staff members should maintain a loyalty to the City and its associates as is consistent with law, personal ethics, and professional standards.

2) Conduct in Dealing with the Public

While representing the City, employees shall be courteous to all members of the public. They shall be tactful in the performance of their duties, control their tempers and exercise the utmost patience and discretion. They shall not engage in argumentative discussions, even in the face of extreme provocation. They shall not use coarse, violent, profane or insolent language or gestures, and shall not express any prejudice concerning race, religion, politics, national origin, lifestyle, or other personal characteristics.

In the event a member of the public becomes abusive on the phone or in person, employees should refrain from escalating the situation and if possible, employ tactics to defuse the situation, e.g. lower the voice, ask the person to sit down. If the situation doesn't improve, the employee can refer the person to a supervisor or request that a police officer be called to the scene. Employees are not required to continue conversations that include profanity or threats. In those situations, the employee should refer the call to a supervisor or inform the caller, as courteously as possible, that the employee is hanging up and will talk with the caller after the caller has calmed down.

3) Conduct between Employees

Employees shall cooperate with and be courteous to co-workers at all levels. While everyone is entitled to their feelings, they are not entitled to act on their feelings inappropriately in the workplace. Employees shall control their tempers and refrain from behaviors that are hostile, offensive, intimidating, degrading, or exploitative. Inappropriate displays include, but are not limited to: slamming doors, pounding tables, kicking furniture, unwanted physical contact of any nature, making threats, berating or belittling others, speaking in raised voices, using coarse, violent or profane language or gestures, refusing to speak or respond when spoken to, and refusing to provide assistance when requested.

Employees shall treat each other with respect. They shall refrain from making remarks about or using nicknames for other employees that are disparaging or based on a personal characteristic; producing cartoons or other graphics displaying other employees in an unfavorable light; communicating threatening or disparaging remarks via any medium (voice, e-mail, notes, etc.); engaging in unwanted horseplay or practical jokes; failing to relay written, verbal or telephone messages; unwanted, unwarranted physical contact of any nature, including "roughhousing" such as punching in the arm, pinching, arm twisting, etc., and other, similar unwanted conduct

4) Reporting Inappropriate Workplace Behaviors

Any employee who feels he or she is being subjected to intimidating, offensive, or harassing behaviors should take the following steps:

- a) If possible, politely but firmly tell the person who is behaving inappropriately that you are uncomfortable with or offended by the behavior and ask them to stop.
- b) Write a memorandum for personal reference that describes the inappropriate behavior, the date the inappropriate behavior occurred, how it made you feel, what you did, how the offending party responded, and the names and titles of any witnesses.

c) If confronting the offending party is not practical or possible, or if the person refuses to discontinue the inappropriate behavior, the employee should, adhering to the chain of command, contact someone on the list below verbally or in writing:

1. The employee's immediate supervisor
2. The employee's Department Head
3. The Human Resources Manager
4. The City Administrator
5. The Mayor
6. The City Council

d) The complaining party should be prepared to provide the following information:

1. The complainant's name, department and position title.
2. The name, department, and position title of the offending party, if known.
3. The specific facts of the alleged inappropriate behavior, how long it has allegedly gone on, any employment action (demotion, failure to promote, dismissal, refusal to hire, transfer, etc.) that was supposedly taken against the employee who is filing the complaint.
4. Names of witnesses, if any, to the alleged harassment.
5. Whether the complainant has previously reported the alleged harassment and, if so, to whom.

5) Investigation of Complaints of Inappropriate Conduct

The Human Resources Manager, the City Administrator, or a designee of the City Administrator, shall investigate complaints of inappropriate workplace conduct.

The determination of whether inappropriate workplace conduct has occurred will be made on a case by case basis. Disciplinary action will also be determined on a case by case basis in accordance with the Personnel Policy, applicable policies of the Police and Fire Departments, and applicable collective bargaining agreements.

Employees who are found to have filed bad faith complaints of inappropriate workplace conduct will be subject to disciplinary action as described in the preceding paragraph.

6) Consequences of Engaging in Inappropriate Workplace Conduct

Employees who are found to engage in inappropriate workplace conduct may be subject to disciplinary action, up to and including immediate termination, subject only to the provisions of the Personnel Policy, applicable policies of the Police and Fire Departments, and applicable collective bargaining agreements.

Supervisors are required to deal swiftly and vigorously with employees who treat others disrespectfully. Any supervisor who condones or allows inappropriate workplace conduct or fails or refuses to respond appropriately to complaints of inappropriate workplace conduct, may be subject to disciplinary action as described in the preceding paragraph, whether or not the supervisor actually engaged in inappropriate workplace conduct.

7) Retaliation for Complaints of Inappropriate Workplace Conduct

All employees are prohibited from retaliating or threatening to retaliate against anyone who complains of inappropriate workplace conduct. Any employee found to engage in retaliatory actions is subject to discipline, up to and including immediate termination, subject only to the provisions of this personnel policy, applicable policies of the Police and Fire Departments, and applicable collective bargaining agreements.

8) Relationship of Code of Conduct to Harassment Policy

This policy supplements and does not replace the City's policies prohibiting discrimination, harassment in the workplace, and workplace violence.

7.2 Harassment Policy

For the purpose of this policy, the term "harassment" includes (but is not limited to) slurs, jokes, other verbal, graphic or physical conduct relating to an individual's race, color, creed, sex, religion, national origin, handicap, age, sexual orientation, marital status, familial status, status with regard to public assistance, status with regard to disability, or other characteristic protected by state or federal law.

This policy applies to all City employees and volunteers without exception including elected officials, temporary employees, employees working under contract for the City and members of the paid-on-call fire department.

Any form of harassment related to an employee's race, color, creed, religion, national origin, sex, marital status, disability, status with regard to public assistance; sexual orientation, familial status, age, or other characteristic protected by state or federal law is prohibited and may result in disciplinary action, up to and including immediate termination.

Sexual Harassment

Sexual Harassment is a serious offense and will not be tolerated. Likewise, retaliation against an employee who makes a complaint of sexual harassment will not be tolerated.

For purposes of this policy, the term "sexual harassment" includes unwelcome sexual advances, requests for sexual favors, sexually motivated physical contact and other verbal or physical contact or communication of a sexual nature when:

1. Submission to such conduct is made either implicitly or explicitly as a term or condition of an individual's employment;
2. Submission to or rejection of such conduct by an individual is used as a basis for an employment decision affecting the individual's employment;
3. Such conduct has the purpose or effect of substantially interfering in an individual's work performance or in creating an intimidating, hostile, or offensive working environment.

Violation of this Policy by an employee may subject that employee to disciplinary action, up to and including immediate discharge.

If an employee believes that he or she is the victim of harassment, or observes harassment in the workplace, the employee should immediately contact one of the following:

1. Immediate supervisor
2. Department Head
3. Human Resources Manager
4. City Administrator
5. The Mayor
6. City Councilmember(s)

All reports of harassment will be thoroughly investigated and appropriate action will be taken. Complaints of harassment will be taken seriously and will be held confidential to the extent permitted by law.

7.3 Workplace Violence Policy

Purpose and Definitions

The city of Ramsey is committed to maintaining a safe environment for its employees and customers, free from violence, threats of violence, harassment, intimidation, and other disruptive behavior. Accordingly, the City will not tolerate any acts of violence toward employees or customers of the City, or to property. Any employee who commits or threatens an act of workplace violence may be subject to investigation and discipline, up to and including immediate termination. It is the goal of the City to provide a workplace that is free of intimidation, threats, and violence. This policy will also seek to provide guidance to employees when they encounter a situation that they believe could result in violence.

For purposes of this policy, the following definitions will be used:

Workplace Violence - The term “workplace violence” encompasses a wide range of behaviors that include, but is not limited to, any act of physical, verbal, or written aggression against an employee or customer of the City, or threats to inflict physical harm, or damages to property, family members of an employee, or any purposeful or knowing behavior which would cause a reasonable person to feel threatened by an employee or non-employee in the workplace. Workplace violence does not include reasonable force in the defense of oneself or others. Workplace violence also does not include the appropriate use of force or weapons by law enforcement officers or others acting lawfully to protect and defend life and property, effectuate an arrest or detainment, or other purposes for which law enforcement officers are authorized to use force.

Threat - an expression by word or conduct of intent to commit violence that places the listener or reader in fear of imminent bodily harm or is of such character that another individual could be placed in fear of imminent bodily harm. The overall context of statement, including non-verbal communications will be taken into account to determine if such an expression is a threat covered by this rule.

Employee Responsibilities

Employees are expected to treat co-workers, citizens, and property with respect. No employee is permitted to commit or threaten violence against another employee or customer of the City. Examples of prohibited conduct include, but are not limited to, physical abuse, verbal threats to inflict physical harm, vandalism, arson, and use of weapons.

Employees are not permitted to bring a weapon into the City workplace or onto City property unless the weapon is required to fulfill the employee's job duties, such as those of a police officer, or is approved by the Department Head or City Administrator.

City employees should not ignore violent, threatening, harassing, intimidating, or other disruptive behavior. If anyone on the City premises displays such behavior, regardless of whether he/she is a City employee, such behavior should be reported immediately to the employee's supervisor. Employees are responsible for making the report regardless of the relationship between the individual who initiated the threat or threatening behavior and the person(s) who was threatened or who was the focus of the threatening behavior.

Employees shall be alerted to and immediately report suspicious or threatening behavior and incidents of workplace violence to their supervisor and should contact 911 in the case of an immediate serious threat or crime. In the event of imminent danger to persons or property, employees shall always take action to safeguard persons or property before making a formal report. Except as noted above, reports shall be made as soon as possible after a threat or act of workplace violence – preferably within 4-6 hours, or sooner if reasonably able to do so.

Even without an actual threat, employees shall report any behavior they have witnessed which they regard as threatening or violent.

Employees who have identified City work locations as being protected for purposes of restraining or protective orders shall immediately notify their supervisor. The City understands the sensitivity of the information and will endeavor to handle the matter respectfully while also providing necessary notification and advance warning to fellow employees.

Supervisory Responsibilities

Supervisors are expected to appropriately intervene when they see an employee on the receiving end of abuse, whether from another employee or a member of the public. Supervisors and Department Heads who witness workplace violence or receive a complaint of workplace violence must notify the Human Resources Manager of the situation as soon as possible. The responding supervisor shall assess whether there is a current significant risk of violence that could result in physical harm to people and/or property and establish command and determine the appropriate level of emergency response. The supervisor or Department Head's efforts may include the following actions:

- Assuring that 911 has been called.
- Alerting other employees in the immediate area about the situation.
- Attempting to move individuals at risk to a safer location.
- Implementing the appropriate evacuation proceeding if rapid evacuation of the building seems warranted.
- Controlling staff involved so that they do not interfere with or hinder the efforts of law enforcement or other emergency personnel who may respond to the incident.

- Assuring that necessary medical attention and/or emotional support is provided to the employees affected by the incident.
- Contacting the Human Resources Manager to arrange for relief from duty of the employee(s) who committed the workplace violence, coordinate an investigation and to handle disciplinary/return to work issues.
- The Human Resources Manager may, in addressing the situation, consider the following:
 - Assessing the needs of victims and other employees impacted by the incident.
 - Any additional security measures that need to be put into place, taking into consideration:
 - the likelihood of violence
 - the costs and benefits of security measures
 - the impact of security measures on the employee(s) involved and the rest of the workforce
 - the impact of security measures on the City’s ability to meet the needs of its customers
- When a supervisor or Department Head is notified of an employee having identified City work locations as being protected areas for purposes of restraining or protective orders, OR of a domestic violence situation, the Human Resources Manager is to be consulted immediately to determine what actions may be appropriate.
- The Human Resources Manager may consult with the Police Department to determine what appropriate security measures need to be taken with regard to any reported or potential workplace violence incident.

7.4 Domestic Violence

At the request of the employee, the City will attempt to make reasonable accommodations for a period of time to shield or protect an employee from abuse while at work through the screening of telephone calls and visitors, or other temporary measures. In accordance with Minnesota law, employees may also use sick leave for “safety” leave related to domestic violence situations.

Due to the need to allow public access to City facilities and services, the City cannot guarantee that violence will not occur on its premises.

The City subscribes to the concept of a safe work environment and supports the prevention of workplace violence. Prevention efforts include, but are not limited to, informing employees of this policy, instructing employees regarding the dangers of workplace violence, communicating the consequences for violating this rule, and providing a hierarchy within which to report incidents of violence without fear of reprisal.

Any City employee who violates this policy may be subject to disciplinary action, up to and including immediate termination.

Any customer of the City who violates this policy may be denied access to City business locations. Anyone who engages in violence may be subject to criminal sanctions.

7.5 Appearance and Dress Policy

The appearance and dress of City employees has a direct reflection on the professionalism of our services. A neat, well-groomed employee presents a positive image of the City and demonstrate the pride of the City employees. Appearance and attire have a definite impact on the way community members perceive City staff and the confidence that customers have in the City's ability to provide quality services. The standard office dress for employees Monday through Friday will be Business Casual.

Appropriate Business Casual Attire

The following information should guide employees on proper dress in the work place. Although it is difficult to develop a policy that will cover all individual variations in dress and style for each work situation or circumstance, the following guidelines have been established based on public image, job safety, and personal hygiene:

However, the Business Casual dress code may be relaxed on Friday's, as described below.

Appropriate business casual dress includes:

- Suits, Pant Suits, Sport Coats.
- Dress slacks, pants, khakis.
- Dress shirt with or without a tie.
- Dresses, skirts and jumpers (no more than 3 inches above the knee).
- Blouses, shirts, sweaters, or pullovers.
- Any type of business shoe.

Appropriate attire for Fridays:

- Casual slacks, pants, denim jeans (as long as they are in good condition with no tears or holes), and capris.
- Casual shirts (no t-shirts), nice sweatshirts or sweaters, (sweatshirts shall not have slogans or advertising larger than 2 inches, other than city logos).
- Athletic shoes in good condition.

Department Heads or their designee will make the final determination on appropriate attire based on working environment, safety concerns, and day-to-day conditions.

Employees who take Friday off cannot substitute another day for "casual Friday."

Inappropriate Attire

Except as allowed on casual Fridays, the following items are considered inappropriate for the office environment. T-shirts or sweatshirts

- Halter tops, tank tops, tube tops, muscle shirts, deck shoes, flip flops.
- Athletic wear (sweatpants, sweat suits, workout clothes, tennis shoes).
- Denim jeans, shorts, mini-skirts, skorts.
- Body-hugging clothes.
- Garments revealing the midriff or off-the-shoulder garments.
- Dirty, ripped, wrinkled or stained clothing.

- Transparent or tight garments.
- Clothing with advertisements or logos larger than 2” (other than City logos).
- Any clothing that is overly revealing or outlandish so as to cause distraction.
- Any clothing or visible tattoos with images or wording that are offensive or derogatory.
- Visible body piercings, other than earrings, must be removed during work hours.

Employees Who Work Outdoors

Employees who frequently work outdoors should take into consideration the nature of their work for the day when determining appropriate dress. Clothing must always be neat, clean, and not overly worn, faded, or in disrepair. Work shirts may not be sleeveless and employees may not go shirtless while on duty. Solid color shorts and jeans are acceptable when appropriate and with prior approval from the Department Head.

Uniformed Personnel

Uniforms, which are provided to some city employees, are expected to be neat, fresh and clean when reporting for duty. Each department is responsible for seeing to it that employees follow regulations regarding uniforms, related accessories and equipment. Uniforms bearing city identification may not be worn during off-duty hours.

Under certain circumstances, as a condition of employment, employees may be required to wear clothing identifying them as a city of Ramsey employee. If applicable, a payroll stipend may be benefited and applicable taxes will be withheld according to the Internal Revenue Service.

Religious Considerations

Nothing in the policy is intended to infringe upon an individual’s desire to observe and exercise religious practices. The City will make reasonable effort to accommodate religious practices regarding dress to the extent that is able to do so without affecting employee or customer health and safety.

Department Heads have the responsibility and the authority to enforce this policy. If counseling does not work, violations of this policy may result disciplinary action, up to and including immediate termination, or sending the employee home to change clothes. Time away from work due to an employee’s violation of this dress code shall not be paid as regular duty pay; the employee may use vacation time or unpaid leave.

7.6 Off-duty Conduct

The City’s effectiveness depends upon the respect and confidence of residents, business owners and employees. Inappropriate off-duty conduct detracts from community or employee respect and confidence. It is the City’s policy to investigate circumstances suggesting that a City employee has engaged in inappropriate off-duty conduct that reflects unfavorably on the City. If inappropriate off-duty conduct is determined to have occurred that affects the City’s business or reputation, discipline may be imposed, up to and including immediate termination.

Examples of inappropriate off-duty conduct include, but are not limited to the following:

- Applicable, concerning moving violations
- Theft
- Violence
- Use of City position to manipulate or control
- Conviction of a gross misdemeanor or felony

This policy applies to all City employees (full-time, part-time, paid-on-call, temporary, casual, etc.); to acts that occur within or outside of City limits; and to acts that occur during or outside work hours.

7.7 Employee Parking

To ensure that the public has easy access to the front doors, employees must park personal vehicles in the Municipal Parking Ramp; unless otherwise approved by the Department Head.

7.8 Conflict of Interest and Divided Allegiance

The City Council and the City Administrator are committed to governing the City organization in a manner that is free of personal conflicts. For the purposes of this Policy, the term “conflicts” means both “conflicts of interest” as they are defined under applicable state and federal law, and “divided allegiances,” as they are defined in this Policy.

This Policy addresses how the City approaches actual or perceived conflicts. The definitions that apply cover more than the specific conflict of interest scenarios addressed by state or federal laws. A conflict of interest not identified in this policy may be a violation of those laws. City officials may have a legal conflict of interest even if their conduct does not amount to a conflict of interest under this Policy. Nothing in this Policy authorizes, or should be interpreted as authorizing, City officials to have an interest in a transaction that is prohibited by state or federal law. Employees and elected officials who have a conflict of interest recognized by state or federal law are subject to all of the consequences provided by law.

The purpose of this Policy is to inform City elected officials, appointed commission members, and staff of the City’s broad definition of Conflicts and to establish procedures to follow to declare and monitor conflicts as they arise. The City Council requires each elected official, appointed commission members and staff member to be advised of this Policy, and each of said persons are to be provided a copy of this Policy, immediately upon assuming their City’s duties or relationship. All individuals subject to this Policy are responsible for knowing and observing the Policy.

This Policy recognizes that a conflict of interest may exist, from a practical perspective, whenever the personal or professional interests of an elected official, appointed commissioner or staff member are potentially at odds with City’s interest(s). Since the City Council is responsible for ensuring that the organization’s management serves the City’s best interests, over and above the interests of any insider, this Policy broadly defines potential conflicts of interest to include all instances when a person within the organization may be able to exert his or her authority, influence, or bias on any issue in which he or she may have divided allegiances.

The City Council recognizes that conflicts may exist not only when an individual has a financial interest in a transaction, but also when his or her nonfinancial interests are involved. In all cases, the City Council is committed to ensuring that whenever a dual interest between an individual's personal, business, organizational or professional affiliations and the position and interests of the City exists, disclosure of such conflict is given and the resulting decision-making is fairly and appropriately managed. Furthermore, this Policy's procedures apply not only when an actual conflict is demonstrated, but also when the interests or concerns of another party to which one has allegiance may reasonably be seen as competing with City's interests or concerns. The decision of the City Council to effect a level of higher scrutiny and procedures when an elected official, appointed commissioner, or staff member of the City appears to have a conflict acknowledges the public's increasing sensitivity to self-dealing and/or lax management by elected officials, appointed commissioners, and staff.

The three types (or "Tiers") of conflicts defined in the Policy are not mutually exclusive. An interest that qualifies as a conflict of interest under one Tier may be a conflict of interest under either of the other Tiers as well, depending on the specific facts.

Conflict of Interest and Divided Allegiances, Definitions

Tier 1 -- Direct conflict: A direct conflict exists whenever there is any proposed transaction or action of the City in which an elected official, appointed commissioner, or staff member has any direct involvement or interest. Direct conflict of interest occurs when a decision or action would compromise a duty to a party without taking immediate appropriate action to eliminate the conflict. These transactions are subject to the highest scrutiny.

Tier 2 -- Indirect conflict: An elected official, appointed commissioner or staff member has an indirect involvement or interest in a proposed transaction or action of the City whenever:

- a) Any other party to the transaction or party affected by the action is a "family member" (i.e., a relative) of the elected official, appointed commissioner, or staff member, or, there is a relationship, affiliation, or other interest that could create an inappropriate influence if the person is called on to make a decision or recommendation that would affect one or more of those relationships, affiliation, or interests.
- b) Any other party to the transaction or party affected by the action is an entity in which the elected official, appointed commissioner or staff member has a material financial interest,
- c) The elected official, appointed commissioner or staff member is an officer, director, trustee, staff member or partner of any other party to the transaction or party affected by the action.

Conflicts involving more immediate relatives should generally be subject to a higher level of scrutiny by the City than those involving relatives who are removed, although each situation involves individual circumstances to be weighed by the City Council and City Administrator.

Tier 3 -- Potential conflict or the appearance/perception of conflict: elected official, appointed commissioner and staff members should follow the disclosure procedures of this Policy when the interests or concerns of any elected official, appointed commissioner or staff member, or of any of those individual's relatives, or any other individual group or organization to which such person has allegiance, may reasonably be seen by a third party as competing with the interests or concerns of the City; that conflicting duties or loyalties exist.

For purposes of this Policy , the term “relative” includes all of the following individuals: spouses, domestic-partners-in-fact, parents, children, children’s spouses or children’s domestic-partners-in-fact, siblings, spouses or domestic-partners-in-fact of siblings, aunts, uncles, first cousins, step-parents and step-children. [“Domestic-partner-in-fact” is used with respect to those designated as the intended life partner of an individual or otherwise identified as being related to that individual through intended long term ties of love, affection, responsibility, and commitment common to those undertaken in marriages recognized by the State, regardless of whether such relationship is defined by or otherwise recognized by any governmental authority.]

For purposes of this Policy, a “material financial interest” exists when an individual or their relative has rights (whether or not yet vested) to be paid compensation, employee or retiree benefits, dividends, or profit-sharing, or to have their expenses reimbursed or obligations or other liabilities repaid, etc. The term is intended to include any and all remunerative expectations.

The City’s elected officials, appointed commissioners, staff, and consultants, shall neither solicit nor accept gratuities, favors, or anything of monetary value from contractors, donors, grantees or parties to sub-agreements, with the exception that unsolicited gifts, such as trinkets or mementos costing \$5.00 or less, not given regularly may be accepted.

When there is any doubt as to whether a conflict exists, either pursuant to this Policy or under applicable law, the matter shall be resolved by the City Attorney.

Procedure When Appointed Officials have a Conflict

When conflicts arise, the interested appointed official must:

1. Prepare a written statement or make a verbal announcement at the applicable public meeting describing the matter requiring action or decision and the nature of the potential conflict of interest.
 - a. Deliver a copy of the notice to the chair of that board, commission or committee. If the chair has the conflict, notice should go to the appointing authority - the city council.

Procedure when Elected Officials have a Conflict

When conflicts arise, the interested elected official must:

2. Prepare a written statement or make a verbal announcement at the applicable public meeting describing the matter requiring action or decision and the nature of the potential conflict of interest.
 - a. Deliver a copy of the notice to the presiding officer (typically the mayor)
 - b. If the mayor has the conflict, notice should go to the acting presiding officer.

Procedure When Staff have a Conflict

1. Each staff member has a duty to disclose to the City Administrator, Finance Director and/or Human Resources Manager of the City the material facts of any proposed transaction of the City in which such person has any conflict(s) identified by this Policy.
2. The disclosure required under 1 (above) is to be made immediately, and to the extent possible, before any consideration of such proposed transaction by the City. If a staff member does not recognize the existence of a conflict prior to a decision regarding the transaction, the staff member has a duty to disclose the material facts

of the conflict as soon as it is recognized.

3. A staff member having a conflict shall not participate in the deliberation or decision by the City regarding the transaction under consideration, unless invited by the City Council, City Administrator, Finance Director, and/or Human Resources Manager to do so, after consideration of the significance to the City of the disclosed conflict. The City Council, City Administrator, Finance Director, and/or Human Resources Manager of the City may also request that he or she provide the City with any relevant information regarding the matter.
4. The City Council, City Administrator, Finance Director and/or Human Resources of the City shall take such additional action as may be required to ensure that the conflict is properly noticed to management and that appropriate steps are employed as the transaction and its terms are brought forth for decision-making and/or implementation. Furthermore, the City Administrator, Finance Director, and/or Human Resources Manager of the City shall maintain a record of the existence, procedures employed in managing, and resolution of the conflict.

SECTION 8 DISCIPLINE/GRIEVANCE PROCEDURES

8.1 Discipline

City employees shall be subject to disciplinary action for failing to fulfill their duties and responsibilities, including failure to observe proper workplace conduct adopted by the City Council. It is the policy of the City to administer disciplinary penalties without discrimination. Except for probationary employees and as expressly described in this Policy, employees may use the grievance procedure as per the personnel policy with respect to any disciplinary action. To the extent practicable, the supervisor or Department Head shall investigate any allegation on which disciplinary action might be based before any disciplinary action is taken.

Nothing in this Policy shall be interested as altering the City employees' status as "at-will" employees or creating any type of "just cause" standard for discipline or termination. When determining whether to impose discipline, including termination, the City may consider all relevant factors, including, but not limited to, the seriousness and frequency of misconduct, and the employee's discipline history.

Discipline may be in one or more of the following forms, although The city of Ramsey reserves the right to take any disciplinary action at any time:

- a) Oral reprimand
- b) Written reprimand
- c) Suspension
- d) Demotion
- e) Termination

- a. Oral reprimand. A verbal reprimand may be imposed by a Department Head for minor violations or incidents. The Department Head must maintain a record of each verbal reprimand. A verbal reprimand may not be appealed or submitted through the grievance process.
- b. Written reprimand. A written reprimand shall state that the employee is being reprimanded for misconduct and describe the misconduct. The employee shall be given a copy of the written reprimand and sign the original acknowledging that he/she has received the reprimand. The signature of the employee does not necessarily indicate that they agree with the reprimand. If the employee refuses to sign the original reprimand, such refusal will be noted on the reprimand. The reprimand shall be placed in the employee's personnel file.
- c. Suspension without pay. Prior to the suspension or as soon thereafter as possible, the employee shall be notified in writing of the reason for the suspension and its length. The employee shall sign the original suspension notice acknowledging that he/she has received it. The signature of the employee does not necessarily indicate that they agree with the suspension. If the employee refuses to sign the suspension notice, such refusal will be noted on the notice. A copy of each written statement shall be placed in the employee's personnel file.

- d. Demotion. The City may demote an employee as it deems necessary in order to address disciplinary concerns or due to performance problems or other factors related to meeting public service needs; demotion results in a reduction in pay, classification, or duties.
- e. Termination. The City may terminate an employee at any time, for any lawful reason or no reason at all. All employees will be notified in writing of the reason for the termination. The employee shall sign the original dismissal notice acknowledging that he/she has received the notice. If the employee refuses to sign, such refusal will be noted on the dismissal notice. The signature of the employee does not mean that he/she agrees with the dismissal. For employees subject to the Minnesota Veterans' Preference Act, the City will provide written notice of the charges against the employee and follow all other provisions of Minnesota Statutes, Section 197.46, as amended.

In any case of suspension, demotion or termination, the employee shall be granted a hearing before the City Council if the employee submits a written request for such a hearing to the City Council within five (5) working days of notification of the action taken. At its sole discretion, the Council may hold the hearing at its next regularly scheduled meeting or any date within thirty (30) days of such meeting. The City Council has the sole discretion to conduct the hearing or to appoint a subcommittee to conduct the hearing. If the Council appoints a subcommittee, the subcommittee shall make its recommendation to the Council at the next regularly scheduled meeting of the Council following the hearing. The Council's decision is final. In the event the Council overturns the disciplinary decision pursuant to this provision, the employee will be reinstated to his/her position with back pay.

For purposes of the Minnesota Government Data Practices Act, the initial disciplinary decision constitutes the final disposition of a disciplinary matter, unless the employee files a timely appeal with the City Council. In such cases, the Council's decision constitutes the final disposition.

Employment at the city of Ramsey may be terminated at the will of either the employee or the City, at any time, and for any lawful reason or no reason at all.

8.2 Grievance Procedure

It is the policy of the City, whenever possible, to prevent the occurrence of grievances and to deal promptly with those that occur. For purposes of this policy, a grievance is defined as a dispute or disagreement as to the interpretation or application of this personnel policy.

Employees shall have the right to present grievances either individually or as a group. Grievances shall be presented to the City Administrator, in writing, within five (5) calendar days of the occurrence of the alleged grievance.

The City Administrator shall respond to an employee's grievance within fourteen (14) calendar days after receiving the alleged grievance. The decision of the City Administrator is final, except that when the City Administrator is directly involved in the grievance, appeal may be made to the City Council for final decision within fourteen (14) calendar days of the City Administrator's decision. In such an appeal, the City Council's decision is final. In the event that the City Administrator does not respond to the grievance within fourteen (14) calendar days of receipt, the grievance shall be considered denied for purposes of the appeal time period discussed above.

In compliance with federal or state law, an employee may also grieve any alleged unsafe act or practice, adverse working conditions, violation of civil rights, and alleged hazardous materials management.

SECTION 9 TRAVEL, TRAINING AND EDUCATION

9.1 Travel Policy

PURPOSE

The city of Ramsey recognizes the need for continued training and professional development for its elected officials and City staff. As part of such training, elected officials and staff may be required to travel to attend workshops, conferences, and other assignments. This policy sets forth the conditions under which such travel will be reimbursed by the City.

POLICY

A request by Council Members for reimbursement for travel expenses must be approved by the full City Council at an open meeting prior to registering for the event. A request by an employee for reimbursement for travel expenses must be approved by the Department Head prior to registering for the event. Requests for travel will be evaluated on all relevant factors, including but not limited to the following:

- Whether the person traveling will be receiving training on issues relevant to the City or to his or her job duties
- Whether the person traveling will be viewing or studying a facility or function that is similar to one being operated by- or considered by-the city of Ramsey
- Whether the person has been specifically assigned by the City Council to testify on behalf of the City before federal or state officials
- Whether the City has sufficient funding available in the budget to pay the cost of the trip

No reimbursements will be made for attendance at events sponsored by- or affiliated with- political parties.

9.2 TRANSPORTATION/AIRLINE TRAVEL CREDITS

The most cost-efficient mode of travel should be used, taking into consideration reasonable time constraints.

Whenever City funds are used to pay for airline travel by an elected official or City employee, all arrangements must be approved by the City Council or Department Head, respectively, prior to City funds being used. All commercial transportation shall be tourist or coach. First-class fares will not be reimbursed. Printed detailed receipts are required airfare and should accompany a request for reimbursement form.

Individuals shall not accept or accumulate travel credits; i.e. travel credits shall be declined by the traveler.

9.3 MILEAGE REIMBURSEMENT

A City vehicle should be used whenever one is available. If a City vehicle is not available, and the Department Head approves use of an employee’s personal vehicle for City travel, the City will reimburse the employee for miles driven in excess of the employees’ normal mileage to and from work at the current IRS rate per mile. Each request for reimbursement must show the following:

1. Total miles traveled on City business, minus normal daily mileage to work from home and from work to home if the employee does not start or end the trip at City offices.
2. Net miles claimed for reimbursement.
3. Business purpose of the trip and entity traveled to.
4. Starting and ending address to substantiate mileage claim.

Example:

The Department Head has approved a full day training seminar held in the City of Anoka. The employee does not start or end the trip at City offices.

Total miles from home to Anoka	16
Return trip to home	<u>16</u>
TOTAL MILES DRIVEN THAT DAY	32
Normal mileage to and from work is 10 miles each way	<u>(20)</u>
TOTAL MILES TO BE REIMBURSED	12

This level of detail must be documented on the request for reimbursement.

If it is necessary to rent a vehicle to conduct City business, the City will reimburse employees or City Council Members for the cost of renting a vehicle. Care should be taken to rent the least expensive vehicle available.

9.4 LODGING

When on City business outside the seven-county metropolitan area, (40 miles or more away from City Hall) lodging accommodations may be provided by the City. Actual costs for a single occupancy room will be reimbursed, but charges shall be reasonable and consistent with the facilities available. In order to keep costs at a minimum, the employee or elected official shall stay at a host hotel or motel, or a less expensive hotel at the discretion of the attendee’s Department Head. The City will not reimburse for costs associated with the attendance of a family member at a workshop, conference, and other assignment. Printed detailed receipts are required for lodging and should accompany a request for reimbursement form.

9.5 MEALS

When on City business, a maximum of three meals per day will be reimbursed by the City. Attendees shall take advantage of all meals that are provided for and included in the registration fee for workshops, conferences, or other assignments. The City will not reimburse for alcoholic beverages, tobacco products or costs associated with family members.

Printed detailed meal receipts are required for and should accompany a request for reimbursement form. The detailed meal receipt must include the food and beverage items ordered. The request for reimbursement form must include an explanation of the public purpose for the meal and a list of the attendees. The receipts and reimbursement request form shall be submitted to the Finance Department for payment.

The maximum reimbursement rates for meals, taxes, and tip are as follows:

Breakfast	\$10
Lunch	\$16
Dinner	\$26

The City Council recognizes the public purpose of the City Administrator's business meetings with developers, staff, consultants, Council members and others; therefore, the City Council grants discretion to the City Administrator to seek reimbursement from the City for business meals, regardless of where or when those meals occur.

9.6 Training and Education Policy

The city of Ramsey is charged with the responsibility of delivering services to a broad constituency of residents and organizations. These services are delivered by staff persons, consultants, and outside agencies. The Ramsey City Council, in an effort to ensure ongoing quality service delivery, provides for a program of training its staff.

It is the primary objective of the training program that training dollars are spent on learning which addresses organizational goals and follows a progression of skill development. On an annual basis, each department is charged with projecting individual staff training needs for the next five years.

The department budget requests and future projections are to be evaluated to ensure compliance with organizational goals and budget allocations. The Department Head is charged with presenting the annual training budget to the City Administrator. The City Administrator is to present his/her recommendations to the City Council as part of the annual budget process.

All departments will be afforded opportunities to ensure training goals are met. However, it is understood that each departments/staff will have varying levels of training needs. The City will not allocate training dollars to specific staff given the varying needs of the organization and the public.

Training Reimbursement

- The City will pay for job-related, position specific training approved by the Department Head and City Administrator and deemed necessary to effectively complete the requirements of the position, provided there is adequate funding in the budget appropriation for training.
- The City will pay for, or reimburse employees for, any and all training required by the City to attain or maintain job-related certification.
- Conference and seminar training shall provide for meals and lodging, if necessary, for in-state and out-of-state training. Travel expenses for in-state training shall be provided through the budget process. Travel expenses shall be provided for out-of-state training with prior approval of the Department Head and City Administrator.

- Department Heads are responsible for providing the Human Resources Manager with records on all employee training done at City expense; upon request a report will be prepared which documents training received and funds expended.

Education-Degree Completion Tuition Reimbursement

All regular City employees are eligible to participate, however it is the expectation of the city of Ramsey that new hires come to the City fully qualified for their position. Therefore, training beyond incidental levels shall not be provided during an employee's first year of service.

Completion of additional education is not a basis for requesting a salary increase. Courses should be taken outside of work hours; however, when unavoidable courses may be taken during the work day with prior approval from the Department Head

Employees wishing to utilize the City's tuition reimbursement funds must: 1) submit a request via a "Pre-Approval for Tuition Reimbursement" form prior to registration of classes; this process should be completed prior to the applicable annual budget process, and 2) submit a reimbursement request form after successful completion of classes; employees should be aware of the following key points

- Employees participating in a job-related Bachelor's Degree program at an accredited college or university or post-secondary classes at accredited colleges, universities, and vocational/technical institutes can apply for City reimbursement for 50% of the cost of tuition, books and laboratory fees. Any other fees, including fees for supplies, transportation, student activity fees, late registration fees, school entrance fees, and graduation fees are not eligible for reimbursement.
- In order to be eligible for reimbursement, the degree program or classes must be deemed by the Department Head, City Administrator, and Human Resources Manager to be job-related and a benefit to the employer before the employee registers for the class.
- Reimbursement will only be made upon receipt of a "C" or better for the course.
- Reimbursement will also be made when employees elect to take classes on a Pass / Fail or Credit / No Credit basis, subject to receipt of successful completion.
- Employees seeking reimbursement must present a paid fee statement and grade transcript in order to receive reimbursement.
- Reimbursement for classes taken at private institutions shall not exceed the tuition charged by Minnesota State Colleges and Universities.
- Reimbursements are on a first come, first served basis and shall not exceed the department budget.
- In the event a department receives reimbursement requests that exceed its budget allocation for education reimbursement, the Department Head and City Administrator shall have the discretion to apportion the available funds, including the discretion to refuse reimbursement.
- In the event an employee leaves the City's employment, any reimbursement for education received during the 12 months prior to leaving must be returned to the City.
- Reimbursements will be made through payroll as either a non-taxable reimbursement or taxable reimbursement; contingent upon current IRS guidelines.

SECTION 10 HEALTH AND SAFETY

10.1 Policy Statement

The city of Ramsey's Safety Program is based on the premise that each and every one of our employees is entitled to a safe and healthy work environment. The Safety Program is designed specifically for the protection of our employees and visitors. All city of Ramsey employees are directed to make safety and loss control important matters.

The City believes that every employee is concerned for their own safety and that of their co-workers and will recognize that the rules and policies contained herein are for their protection. The goals that we have set for our Safety Program can only be achieved through a cooperative effort between all employees. Safe working habits and an awareness of all safety rules and policies are a condition of your employment at the city of Ramsey. All employees are required to familiarize themselves with every rule and policy set forth and to abide by them. These rules and policies will be enforced just as any other City policy and failure to comply can result in reprimand, suspension, or employment termination.

All employees are encouraged to make suggestions which will assist in maintaining safe working conditions, and to bring to the attention of their supervisor any unsafe working conditions. It is through our joint participation that accidents can be prevented, but the individual employees, can make safe work practices a habit.

This policy toward safety is in no way limited to the rules that follow, and any unsafe practices, whether listed here or not, will be addressed on a case-by-case basis.

The city of Ramsey is committed to providing its employees with a safe and healthy work environment.

10.2 Health and Personal Safety

Health and personal safety are some of the best guarantees for the successful performance of employees' work. Employees must work safely using the safety devices and equipment provided by the City for their protection. Employees must promptly report safety hazards to their supervisor. Unsafe conditions will be investigated and corrected, as necessary.

10.3 Workers' Compensation / Injuries and Illness at Work

Both Minnesota Worker's Compensation laws and the state and federal Occupational Safety and Health Acts require that all on the job injuries and illnesses be reported as soon as possible by the employee, or on behalf of the injured or ill employee, to his/her supervisor. The employee's immediate supervisor is required to complete a First Report of Injury and any other forms that may be necessary related to an injury or illness on the job. First Report of Injury forms must be submitted to Human Resources as soon as possible, but no later than 3 business days from the date of injury.

Pursuant to Minnesota State law, the officials of the City elected or appointed for a regular term of office or appointed to complete the unexpired portion of a regular term are included in the coverage of the Minnesota Workers' Compensation Act.

10.4 Medical Procedures

It is the policy of the city of Ramsey, within the confines of the Minnesota Human Rights Act, to require its employees to be examined by a physician after an injury is sustained, whenever conditions make this desirable for the employee or the City, or whenever management determines that the interests of the City and the employee will be served thereby. Physical examinations administered at the request of management shall be paid for by the City.

10.5 Smoking Policy

The city of Ramsey bans smoking in all municipal buildings, equipment and city vehicles. Smoking for the purpose of this policy means inhaling or exhaling from any lighted cigar, cigarette, pipe or any other lighted tobacco, plant product, or substance that may be used for smoking in lieu of tobacco intended for inhalation via any of the means listed above. Use of electronic devices which simulate smoking are also prohibited. This includes, but is not limited, to electronic or “e” devices such as e-cigarettes, e-cigars, e-pipes. Electronic devices are prohibited regardless of whether they provide vapor of liquid nicotine, lobelia, and/ or other substances. Non-electronic devices which simulate smoking are also prohibited.

10.6 Inclement Weather Policy

On occasions when the severity of the weather may cause City offices to be closed, the City Administrator will make a determination as to whether the offices will be closed. The City Administrator will then notify staff via email of the closure. Staff that do not have email access are responsible for contacting their supervisor. If it is broadcast that City offices are closed prior to the shift start time, then the employee will be paid as if it were a regular workday. If, however, the office is not officially closed, staff will be instructed to take vacation time or compensatory time off for any absence from work that occurs. If the office is officially closed after the start of the shift, staff will receive their regular pay for the remainder of the shift. Compensatory time off or vacation will be taken for time absent from work prior to the official closure. This policy will apply to office employees only and does not include Public Works or Public Safety (fire and police) employees. In circumstances where the City Administrator is out of town, the Acting City Administrator will provide the decision on whether or not to keep City offices open due to inclement weather.

10.7 Municipal Center Severe Weather Plan/Other Emergency Plan

In the event that severe weather or another emergency occurs during the course of the day, staff and occupants of the Municipal Center shall seek shelter in designated areas while also maintaining accountability of all persons in building.

Requirements:

Anoka County Dispatch (911) may activate the outdoor warning devices when a certified weather spotter witnesses severe weather or the National Weather Service indicates that severe weather will threaten all or part of Anoka County. Although the County has the ability to sound the sirens in zones, its common practice is to alert the entire County. If the outdoor warnings do not activate or there is a different emergency, a member of Public Safety (Police or Fire) shall have the authority to enact the emergency plan.

During normal business hours when the outdoor warning sirens sound or as directed by a member of Public Safety (Police or Fire), all employees will move to the primary shelter area. If the primary site is full, then the secondary locations will be used.

- Police Locker Rooms (Men and Women) -Primary.
- If necessary, secondary locations will be determined by a member of Public Safety and employees and visitors will move to that area as directed.

If non-staff members are present in the Municipal Center, staff should direct them to move to the primary site. If the primary site is full, then the secondary sites will be used. If any members of the public or visitors are within the Municipal Center at the time when a weather emergency, it is the responsibility of the Department Heads to get them to the shelter location.

A member of Public Safety will notify all areas when the situation has become stable and all persons may return to normal activities.

During non-business hours a member of Building Maintenance will guide all groups to the Police Locker Rooms and remain with the group until the situation has become stable. When weather has been determined safe, the Building Maintenance person will allow the groups to return to their normal activities.

Responsibilities:

If necessary the Department Head or their designee will determine accountability of their respective group and/or other departments. A member of Public Safety will gather names of the individuals at all three shelter sites to determine personnel accountability.

A member of public safety will make a sweep of the Municipal Center to ensure that all employees and any of the general public have evacuated to the shelter area.

Field Employees:

During an actual severe weather incident, city personnel working outside of a City building, should seek shelter based on their respective Department's severe weather plan or in an area that they feel creates the safest environment.

10.8 Hepatitis-B Vaccine Policy

Hepatitis-B is a viral liver infection which can be debilitating and in some cases, fatal. Because Hepatitis-B is transmitted through body fluids such as blood, certain groups of people are at a greater risk of infection than others.

The Federal Occupational Safety and Health Administration (OSHA) has stated that all employers must evaluate their employees to assess the risk of Hepatitis-B infection, as it relates to their jobs. If a substantial exposure risk is assessed, the employer must offer the vaccine to those employees at no cost to the employee.

The employees within the city of Ramsey who have been identified at substantial risk of Hepatitis-B infection are Public Works Maintenance staff, Patrol Officers, Community Service Officers, Reserve Officers, and Fire Fighters.

Any employee who, while on the job, is exposed to blood, body fluids or a needle stick is required to: 1) Contact their supervisor as soon as possible, and 2) Complete a First Report of Injury form to be submitted to Human Resources immediately. The supervisor will initiate appropriate action or contact their Department Head for guidance.

10.9 Housekeeping

All employees need to assume a share of the responsibility in maintaining a high standard of cleanliness and orderliness, and cooperate in maintaining safe, healthful and sanitary conditions in all work areas. A clean work area will make your work more pleasant and help maintain the high standards of quality necessary to meet the professional requirements of the City's services.

SECTION 11 USE OF CITY PROPERTY

All staff members are responsible for the safekeeping and proper care of all property used by them and belonging to the City. Property shall only be used for official purposes and in the capacity for which it was designed.

City employees shall have no expectation of privacy in any property or equipment of the City, including, but not limited to, offices, cubicles, desks, files, vehicles, filing cabinets, voice mail, text messages on City paid cellular telephones, PDAs, computers, laptops, mass storage devices, e-mails, electronic media or devices of any kind, or any other type of equipment, property, or space provided by the City. Except when accessed by the Police Department for law enforcement purposes, any such property or equipment may be accessed by the City at any time, for any purpose, with or without notice to the employee, and with or without reasonable suspicion.

11.1 Public Information

All staff members shall become familiar with- and must comply with- all applicable laws dealing with public and non-public information. Misuse and improper disclosure of public or non-public information is prohibited and may result in discipline, up to and including immediate termination.

11.2 Telephone Use

The proper use of telephone communication is required. Always answer the telephone with a pleasant voice and respond politely to the caller. Personal telephone calls must be brief. Frequent use of the telephone for other than City business is not permitted and may result in discipline, up to and including immediate termination.

11.3 Information Technology Policy

Purpose

The purpose of the city of Ramsey IT Policy is to set standards to protect the City's IT systems from business interruption, unauthorized or inappropriate access, and to maintain appropriate security. The policy is to be adhered to by all users (full-time, part-time, and temporary employees, vendors, consultants, volunteers, interns, and others) who have access to or use the city of Ramsey IT systems both on and off City property. IT systems include, but are not limited to, computers, e-mail, Internet, Intranet, printers, software, telephone, voice mail, cell phone, smart phone, etc.

There are two subsections of this policy. The first is related to IT usage and the second is related to IT Security.

Violations

Violations of this policy will be addressed consistent with the City's Personnel Policy or union contract and may include disciplinary action, up to and including immediate termination.

Exceptions

Exceptions to the following policy must be reviewed on a case by case basis by the Department Head and approved by the City Administrator.

Glossary of Terms

Configuration: The way a system is set up or the assortment of components that make up the system. Configuration can refer to either hardware or software or both.

Downloads: To copy data from a main source to a computer device.

Electronic Mail (e-mail): A network application that allows users to exchange messages over communications networks with others.

File Server: An enhanced computer with network operating software that is used for file storage, application functionality, and managing network resources.

Information Technology (IT): Managing and processing information.

Information Technology Systems: Includes, but not limited to, computers, printers, software, e-mail, Internet, telephone, voice mail, cell phones, etc.

Internet: A global network connecting millions of computers.

Intranet: Network base access accessible only within an organization. An intranet 's Web sites look and act just like any other web site, but firewall security restricts unauthorized access.

Local Area Network (LAN) – A localized computer network.

Licensing: Legal compliancy of assets.

Social Networking Sites: Sites which focus on building online communities of people who share interests and activities and /or exploring the interests and activities of others. Examples of social networking websites include: Facebook, MySpace, Friendster, Linked In, Twitter, and sites that allow users to post personal blogs, etc.

Software: Software includes the operating system and all utilities that enable the computer to function. Application software includes programs that do real work for users (i.e. word processors, spreadsheets, and database management systems).

Portable Equipment: Hardware that is small and lightweight (i.e. laptop computers, hand-held computers, tablets, smart phones, Blackberrys, projectors, digital cameras, etc).

Users: Full-time, part-time, and temporary employees, vendors, consultants, volunteers, interns, and others who have been granted access to the City's Information Technology Systems.

Information Technology Use

Purpose

Inform and provide direction to all users regarding appropriate usage and management of the City's IT systems and resources. All users must be authorized to use City IT systems by their Department Head, supervisor, or IT.

Auditing

The city of Ramsey reserves the right to monitor and audit use of its IT systems at any time without the user's consent. An audit may result in the removal of hardware and/or software not compliant with this policy, revocation of permission to use the City's IT systems, employee discipline, up to and including immediate termination, and/or criminal charges, depending on the nature of the violation.

Reporting

Users should notify their immediate supervisor, the IT Manager, Human Resources, or the City Administrator upon learning of violations of this policy.

Expectation of Privacy

As discussed above, all City owned equipment and Information Technology Systems, including e-mail, are City property and subject to inspection by the City at any time, without notice, and for any reason or no reason at all. Users should have no expectation of privacy. In addition, the City is subject to the Minnesota Government Data Practices Act and other laws governing the collection, storage, use, and disclosure of data. All files and documents, including personal messages and internet logs, created, received, collected, or generated by City employees or using the City's Information Technology Systems are subject to those laws and may be disclosed in certain circumstances without the permission of the employee or user.

Violation of Policy

Violations of this policy will be addressed consistent with the City's Personnel Policy or union contract and may include discipline up to and including immediate termination, , revocation of permission to use the City's IT systems, and/or criminal charges, depending on the nature of the violation

Hardware and Software Acquisition

The IT Manager must approve all hardware and software prior to acquisition to ensure consistency with the design and architecture of the City's IT network. Users are prohibited from installing, downloading, or acquiring hardware and software, including product demonstrations, without prior approval from the IT Manager. Software applications not required for official City business are strictly prohibited.

Installation, Downloads, and Configuration

No user will be allowed to manipulate hardware and software standard configurations. The IT Manager must be contacted for hardware and software support. No user should change the computer setup or configuration files. Customizing a computer should be limited to

items including City-owned software such as wallpaper, screen savers, icons, toolbars and colors. Users are prohibited from downloading, or installing any software including personal, through the Internet, e-mail, and/or vendor demonstrations without prior approval from the IT Department. In order to maintain optimal functioning, users are encouraged to accept updates to currently authorized programs such as Adobe Acrobat and other previously installed software.

Licensing

To ensure license compliancy all software must be purchased by and licensed to the City.

- a. **Development:** Any software programs (i.e. custom designed Microsoft Access databases, etc.) developed for use by the City becomes the property of the City. Software programs may not be sold or distributed without prior approval.
- b. **Home:** City-owned software may not be loaded on non-City owned equipment unless there is prior approval of Department Head and IT Manager.
- c. **Copyright Laws:** City users are required to abide by software and documentation copyright laws and licensing agreements. Question about the legality of the software and documentation should be directed to the IT Manager. At no time should any users make copies of City-owned software and documentation. To prove legal ownership of software, the City must have the original media and manuals stored on City property. The IT Manager will periodically check for software that may be in violation of the above policy.

Data Management and Protection

- a. Under the provisions of the Minnesota Data Practices Act, all data stored on computer media owned, leased or rented by the City is considered to be owned by the City is subject to the Minnesota Data Practices Act, which governs its use and dissemination and data classification. All data is also subject to review and investigation at the discretion of the City Administrator, Department Heads, IT Manager, and/or law enforcement. The City Clerk should be contacted with questions regarding the classification of public and private data.
- b. **Data Ownership:** All information developed or introduced to a City technology system by a user in conjunction with employment with the City is the property of the City.
- c. **Data Storage:** All City data must be saved to a network drive on a City server.
- d. **Data Deletion:** Users are responsible for deleting outdated files that are no longer needed for compliance with of the City Records Retention Schedule; this includes data files and e-mail messages. The City Clerk should be contacted with questions regarding the City Records Retention Schedule.
- e. **Data Back-up:** The IT department backs up all data stored on the file servers.
 - a. Workstation hard drives or any other devices are not backed up.
- f. **Portable files:** To facilitate off-site work, users may copy appropriate files to and from jump sticks/CDs including word processing, spreadsheets, and presentation graphic files.

No other files or information may be copied to or from the City computers. A current copy of the portable file(s) must be maintained on the City server. All users are responsible for maintain data privacy of all data transmitted in this fashion.

- g. Password Protection: If any software product that the City has purchased has the option to have file's password protected, the password must always be shared with the appropriate management personnel and/or the IT Manager.

Portable Information Systems

Portable personal computer(s), digital cameras, projectors, and other City owned portable equipment can be used for City business, outside of City facilities. When users check out portable equipment they are expected to provide appropriate "common sense" protection against theft, accidental breakage, environmental damage and other risks. Desktop computers and attached devices are not to be removed from City buildings. The user is responsible for the backup of or loss of any data stored on the standalone or portable computer. IT staff is available to assist in the development of procedures for disaster recovery of portable units.

City Issued Cellular Phones

- a. City issued cellular telephones are intended for the use by City employees in the conduct of their official City work to perform services to Ramsey citizens and businesses. Department Heads are responsible for the cellular telephones assigned to their departments, determining service levels for their employees, and exercising discretion in their use. Employees will manage their cell phone use so as not to exceed their service level as approved by their supervisor. Occasional overages will be reviewed by the supervisor on a case by case basis. After a review of the monthly billing statement, employees may be required to reimburse the City for overages in cell use and/or texts, depending on the nature of the calls/texts made during the month. Employees will make an effort to utilize the Nextel Direct Connect and/or a land line before utilizing cellular minutes. Nothing in this policy will limit Department Head discretion to allow reasonable and prudent use of such telephones or equipment provided that:
 - i. Its use in no way limits the conduct of work of the employee or other employees
 - ii. No personal profit is gained or outside employment is served
- b. A Department Head may authorize an employee to use their own personal phone for City business and be reimbursed by the City for those calls. An employee will not be reimbursed for business-related calls without prior authorization from his or her Department Head. Department Heads may also prohibit employees from carrying their own personal cell phones during working hours if it interferes with the performance of their job duties.
- c. Use of public resources by City employees for personal gain and/or private use including, but not limited to, outside employment or political campaign purposes, is prohibited. Incidental and occasional personal use may be permitted with the consent of the department director and direct supervisor.

- d. Personal calls made by employees on a City-provided cellular phone will be made or received only when absolutely necessary and when they do not interfere with working operations and should be completed as quickly as possible.
- e. The Administrator, or designee, will have primary responsibility for implementation and coordination of this policy. All Department Heads and supervisors will be responsible for enforcement within their departments and divisions.

Smart Phones/Tablets

Users acting within the scope of their job responsibilities and with Department Head approval, may personally purchase smart phone/tablet from an IT approved and published list of brands and models. IT staff will install approved smart phones/tablets on City owned equipment. The city may at its discretion provide devices to members of staff it deems appropriate.

Electronic Mail (e-mail)/SMS (text) Messaging

- a. The City e-mail system and City owned or issued cellular phones are tools to be used for matters directly related to the business activities of the City and as a means to provide services that are efficient, accurate, timely and complete. E-mail messages and texts are subject to regulation under the Minnesota Data Practices Act. The content of the message determines whether a message is public or non-public/private. E-mail is intended as a medium of communication, not for information storage; therefore, e-mail should not be used for the storage or maintenance of official City records or other City information. Users may receive inappropriate and unsolicited e-mail messages. Any such messages should be reported immediately to the IT department.
- b. Inappropriate non-business use of the City e-mail system and cellular phones includes, but is not limited to; the transmission of non-business audio, graphic or movie files; games; jokes; instant messaging; chain emails; content of an offensive, indecent, or pornographic nature; copyrighted material and large data files not directly related to City business. These items must not be sent or accepted as e-mail attachments. These types of files can be large and affect the network or computer performance or carry viruses.
- c. Users must practice the utmost respect while texting and may not use text messaging, e-mails, or other forms of communication provided or authorized by the City to harass another employee, citizen or other individual. "Textual harassment" is considered harassment and is subject to investigation and disciplinary action as described in the Anti-harassment Policy.
- d. The City retains the right to use management software to eliminate the delivery of junk e-mail (SPAM), including e-mails that contain profanity.

Internet/World Wide Web

- a. The Internet is available to users for research, education, and communications directly related to the mission, charter, or work tasks of the City. Users must honor copyright laws regarding protected commercial software or intellectual property. Users accessing

Internet through the City's IT systems should minimize unnecessary network traffic that might interfere with the ability of others to make effective use of this shared network resource. Users are responsible for adhering to City standards when browsing the Internet. Failure to adhere to City standards puts the City and the individual at risk for legal or financial liabilities, potential embarrassment and other consequences, including immediate termination of employment or other disciplinary actions.

- b. The City retains the right to use management software to monitor end user activity. This software may monitor and limit Internet activity.

Prohibited Use

The following list provides examples of inappropriate and prohibited content. This list includes, but is not limited to illegal activities; profit or commercial activities; outside employment; any other public office or employment which is incompatible with City employment responsibilities, as determined by the City Administrator; wagering, betting, or selling chances; annoying or harassing other individuals; fund-raising, except for City approved activities; any political or religious activities; unethical activities; pornographic, obscene, or indecent images or content; forwarding of junk e-mail, advertisements, and/or chain email.

Personal Use

- a. The city of Ramsey offers users the privilege of personal use of its technology. Personal use is allowed under the following guidelines listed below and only during break times or before/after normal business hours, as follows: Users must obtain approval from their immediate supervisor prior to personal use of IT systems; only City users are to use the computers and computer related peripherals; users must use their own media (flash drives, CD's) and paper. No personal files or data are to be stored on the City file servers; users must not use IT systems for items listed above in Prohibited Use.
- b. E-mail: E-mail may, on a very limited basis, be used for personal correspondence, as long as it does not interfere with the normal duties of the employee and the above-listed guidelines are followed. Using the City Internet e-mail to participate in any kind personal listservs or broadcast mailing list is prohibited.
- c. Inappropriate non-business use of e-mail and the Internet can cause a burden on resources or carry computer viruses. Examples of this includes, but is not limited to: the transmission of non- business audio, graphic or movie files; games; jokes; instant messaging; content of an offensive or pornographic nature; copyrighted material and large data files not directly related to business. These items must not be downloaded from the Internet. These types of files can be large and affect the network or computer performance or carry viruses.
- d. Desk Telephones: Desk telephones may be used for short, infrequent personal use as long as it does not interfere with the normal duties of the employee and the above guidelines are followed. Employees must pay any costs associated with personal long distance calls within 30 days.

- e. Copiers, Fax Machines, Printers: Users will reimburse the city of Ramsey for personal copies, faxes, and print requests, at the rate listed in the City fee schedule. Personal use fees must be reimbursed within 24 hours from the date the expense was incurred.

Personal Social Networking on City-owned equipment

Individuals must not use City-owned or operated equipment to post to personal sites, including social networking sites, except during break times or before/after work.

Personal Social Networking while off duty and the City's Responsibility:

The city of Ramsey has a duty to protect the reputation of the organization and its employees as well as guard against any liability and potential legal risk regardless of when and where social networking activity occurs. With this in mind, employees must use social media in a manner that follows the following guidelines, as follows: individuals should exercise caution and good judgment when social networking; individuals shall not represent that they are speaking or acting on behalf of the city of Ramsey or presenting any interests of the city of Ramsey; individuals are not permitted to display the city of Ramsey logo on any part of their online profiles; individuals never have the right to post non-public and confidential information such as information related to coworkers without first obtaining the individuals' express written consent, personnel data, medical information, or claims or lawsuits against the City; individuals who use personal social media accounts are not immune from the law.

In general, all users of social networking should be aware that the content of these social networking sites can be subpoenaed and used in criminal and civil trials. Individuals need to be aware that they have no reasonable expectation of privacy when social networking and use of personal social media accounts are subject to all pertinent city of Ramsey policies, as well as local, state and federal laws. Content that violates existing City policies that exhibit hate, bias, discrimination, pornography, libelous or otherwise defamatory content will not be tolerated. Individuals are prohibited from using social networking sites to harass or attack others, including those who work for the city of Ramsey

City Facebook page or other City social networking sites:

- a. Authorized city staff responsible for updating social media sites must use the greatest care to portray the City in the possible best light.
- b. If the author of a given post is quoting another individual's comments, the comments must be called out as a quote with quotation marks.
- c. In general, all posts should be reviewed by a supervisor.

Information Technology Security

Purpose

Ensure secure, protect, and allow appropriate access to city of Ramsey IT systems and resources.

Logins and Passwords

All users must use and maintain unique IT-issued login IDs for computer and network-related access. Login IDs are not to be shared with others, and corresponding passwords must remain confidential. Multi-user or generic login IDs are permissible only in special circumstances approved and maintained by IT. User passwords must adhere to the following requirements:

- o Have a minimum of at least six alphanumeric characters in length
- o Must be changed every 180 days
- o Have at least one numeric digit as well as letters, for example: jarg0n5
- o Have not been previously used in the last five password rotations
- o Automatic screen lock is initiated with the screensaver after 15 minutes of inactivity.

Appropriate network access shall be assigned by the IT department to each user login ID, and users may only log into computers and equipment with their assigned login ID. Passwords are not to be shared with anyone, and will be forced to change periodically. New passwords should not be easily guessed. Any employee who forgets their password or suspects that their password's security has been compromised, may contact the IT department to be issued a new one, which must then be changed immediately.

Physical Security

- a. City users are expected to provide reasonable security to their computer workstations and related IT equipment. This includes ensuring that passwords are not written down in accessible places, removable media must be kept in a secured area, and that confidential data is not displayed in such a manner that unauthorized personnel can view it.
- b. All IT equipment is City property and must remain on current premises. Users may not move IT equipment outside of its assigned area without prior approval from the IT department. Designated portable equipment, such as projectors, laptop computers, and digital cameras, may be removed from City buildings only for City business. Portable equipment must be reserved and checked out only to City users. Users are expected to provide appropriate "common sense" protection against theft, breakage, environmental damage, and other risks.
- c. Users are required to log off computer workstations when absent for an extended time, such as end of day. Users may, however, "lock" their workstation instead when absent for a short period of time, such as during a meeting or over lunch.

Virus Protection

All computer workstations, laptops, and servers must be protected from viruses using up-to-date antivirus software. Users may not alter their system's configuration or take other steps to defeat virus protection devices or systems. All files on removable media must be scanned for viruses prior to installation onto or access from City computer equipment. Any files suspected or known to contain viruses must be immediately reported to the IT department for proper handling.

Wireless Access

Unauthorized wireless access into the City's computer network is strictly prohibited. Wireless access is defined as, but not limited to, 802.11 (Wi-Fi), Bluetooth, WiMax, and cellular technologies. Users may not attempt to scan, connect to, or install any wireless computing device on City equipment or property. Wireless access must be authorized and configured by the City's IT department. Any authorized wireless access must utilize standards-based encryption, and conform to adopted security practices as governed by LOGIS and/or state and federal government guidelines.

11.4 Vehicle Use Policy

Staff members shall operate City vehicles in a careful and prudent manner and shall obey all laws of the state and all City orders pertaining to such operation. Staff members shall set a proper example for others when operating City vehicles. Any City employee who drives a City vehicle regularly or occasionally in order to conduct City business, must promptly report loss or suspension of a driver's license to the Department Head.

The intent of this policy is to ensure appropriate use of City vehicles by municipal employees and to ensure a clear understanding thereof.

- a. Conferences, schools, seminars and meetings: For purposes of this policy it is intended that training opportunities during the regular work shift within a 40-mile distance of the work location is considered an acceptable work-related activity in as much as the vehicle will be returned to the work site either during or shortly after the completion of the shift.
- b. Out-of-town and overnight conferences and schools: For travel which has a duration of more than one work day in length, or for travel beyond the 40-mile radius noted above, the employee is to utilize a non-fleet vehicle, the use for which will be compensated at the approved rate. Alternatively, upon prior approval of the City Administrator, the employee can receive the use of a vehicle previously determined as an excess vehicle by the City Council.
- c. Lunch hours and authorized breaks: For purposes of this policy when an employee is scheduled to work at a site other than their normal reporting location, and for Police Officers on duty, use of a City vehicle for travel within one mile of the City limits for the purpose of lunch and other authorized breaks shall not be considered personal use.
- d. Overnight use: It is the intent of this policy that all municipal vehicles will have returned to their designated work location by the end of the work shift unless prior written authorization has been received from the City Administrator.
- e.. Personal use: Personal use of City vehicles by City employees or elected officials is prohibited without the express written consent of the City Administrator or his/her designee.

11.5 Telecommuting Policy

Telecommuting is a work arrangement where the employee works from home or another remote work site away from the primary traditional work place.

Purpose

Consideration for telecommuting arrangements may be made on a case by case basis and only in situations where the employee can demonstrate a benefit to the City. Telecommuting is not appropriate for all employees, it is not a City wide benefit or entitlement, in no way changes the terms and conditions of employment with the City and is not a substitute for dependent care.

Participation

Full-time employees, except those under collective bargaining agreements, may apply to participate. Employees must have successfully completed probation, received a satisfactory rating on their last performance evaluation and not had any disciplinary action taken against them during the past year. Seniority will not be a basis for selecting employees to participate in this program.

Application Process

The telecommuting application must be completed indicating how the telecommuting will benefit the City. All applications must be signed by the Department Head and then forwarded to Human Resources. The Department Head, Human Resources and the City Administrator will evaluate the application to determine whether or not the application will be approved or denied, at the sole discretion of the City Administrator. The Department Head will then meet with the employee regarding the determination.

Telecommuting Program

It is recommended that employees who telecommute do so for a maximum of two days per week, or on a short-term project basis. The telecommuter and the Department Head should agree upon a regular schedule of work hours and work location. Following the regular work schedule is necessary to ensure maximum accessibility. However, the employee must be willing and able to return to the primary work place at the request of the Department Head for any reason with minimal notice. An employee's salary, benefits and job responsibilities will not be affected by participating in telecommuting. Overtime must have prior approval. A remote work site is considered a City work space and the employee, therefore, continues to be governed by applicable City policies, procedures, or practices.

The employee is to be available for telephone, computer and/or fax communication with the City at the times as agreed by the signers on the application. The employee will respond to telephone calls at the telecommuting work location, and will respond to telephone messages left for the employee at the employee's City work location.

The Department Head and telecommuter must establish an agreed upon schedule where the telecommuter contacts the office to report progress.

The telecommuting projects must have measurable objectives. For example, writing a section of a manual, working on a special project, or preparing spreadsheets and financial analysis

where being out of the “office environment” could lead to its accomplishment in a more timely manner.

Equipment

If an employee is approved for telecommuting and the project requires the use of a computer, printer or other computer equipment, the cost of the equipment, maintenance repair of the equipment, equipment insurance, electricity, and/or phone lines are the employee’s responsibility.

The cost of installing and licensing software will be at the City’s expense as long as a software license already exists for that particular user.

In the case where an employee owns a personal computer, the employee must provide a copy of the appropriate documents to verify that the software being used is legally licensed and receive virus-detection training from the IT Division. The City assumes no liability for loss, damage or wear of employee-owned equipment.

Telecommuters will take all precautions necessary to secure confidential and/or proprietary information and prevent unauthorized access into any City system.

Insurance

The employee will be covered by Worker’s Compensation while working at the telecommuting work address during the hours of work as indicated on the Telecommuting Application. The city of Ramsey’s liability is limited to injuries resulting directly from the work and only if the injury occurs in the designated work area. Any claims will be handled according to regular Workers Compensation procedures. If injured while telecommuting, the employee should follow the appropriate procedures for reporting the injury. Other family members or visitors to the telecommuting work address are not covered by the City’s Worker’s Compensation program. The city of Ramsey is not liable for any injuries to family members, visitors, or others in the employee’s home. Employees should consider carrying insurance to cover these instances.

Telecommuters working at home will have a designated space maintained by the employee. With advance notice, the employer may visit the work site to ensure that safe work conditions exist. For projects involving extensive computer use, staff may request an ergonomics evaluation of the work area.

Expenses

The City will not reimburse the employee for any expenses the employee incurs to participate in telecommuting. This includes equipment, utilities, supplies and furniture. The City will provide a small and reasonable number of office supplies (such as pens, paper, post-it notes, and paper clips) for use by the telecommuter.

Travel time from the home to the workplace is not compensatory, even if the employee reports to the regular workplace on a day scheduled for telecommuting.

SECTION 12 Drug Free Workplace Policy

12.1 Drug Free Workplace Policy Statement

In accordance with the "Drug-Free Workplace Act of 1988", the city of Ramsey hereby notifies its employees that the unlawful manufacture, distribution, dispensing, possession or use of a controlled substance, as defined by law, is prohibited at the time and in the course of any activities performed in conjunction with the employee's work-related responsibilities. It is important to note that not only is the use of illegal drugs unlawful, but also the illegal dispensing of legal (prescription) drugs.

As a condition of employment with the city of Ramsey, all employees will abide by the terms of this Drug-Free Workplace Policy and will notify the City Human Resources Manager in writing of any criminal drug arrest or conviction no later than five days after such arrest or conviction. Employees who violate this policy may be subject to disciplinary actions which may include suspension or immediate termination.

Employees who are convicted of a drug related violation in the workplace or while engaged in work-related responsibilities may be required to participate in a drug abuse assistance or rehabilitation program approved for such purposes by a federal, state, or local health, law enforcement, or other appropriate agency. Appropriate personnel action shall be taken against such convicted employee up to and including termination of employment. The City reserves the right to terminate any employee who has been arrested for, pled guilty to, or convicted of any crime involving the operation of a motor vehicle under the influence of illegal drugs, alcohol, or other controlled substances. This includes all such crimes occurring outside of work hours and all such crimes involving the use of any vehicle owned or leased by the City, the employee's personal vehicle, or any other vehicle.

Employees are also encouraged to attend one of the drug-free awareness programs which may be offered periodically. Other parts of the drug-free program may include drug counseling and employee assistance programs in the future.

12.2 Drug and Alcohol Testing

General Policy: It is the policy of the City to provide a drug-free environment. The City's goal is to establish and maintain a healthy and efficient workforce free from the effects of drug and alcohol abuse in compliance with the requirements of the federal Drug-Free Workplace and other applicable law.

The City recognizes drug and alcohol abuse as potential health, safety and security problems. Employees needing help in dealing with drug and alcohol problems are encouraged to make use of the medical resources available through their health insurance plans.

Employees are required to report to work on time and in appropriate mental and physical condition for work. No employee shall be under the influence of any illegal drug, alcohol, or

other controlled substance while the employee is working, while the employee is on the employer's premises, representing the City away from the workplace during work hours, or operating the employer's vehicle, machinery or equipment, except to the extent authorized by a valid medical prescription.

Unless specifically authorized as part of the employee's work duties, no employee shall use, possess, manufacture, distribute, dispense, sell, or transfer drugs, alcohol, or drug paraphernalia while the employee is working, while the employee is on the employer's premises, representing the City away from the workplace during work hours, or operating the employer's vehicle, machinery or equipment, except to the extent authorized by a valid medical prescription. Off duty employees may use or possess alcohol on City premises such as parks and parking lots when said use and possession is not prohibited to members of the general public. The sale of alcohol which is part of an employee's job duty is an exception to this policy.

Violations of this policy will result in disciplinary action, up to and including immediate termination, and may have legal consequences.

As a condition of employment, each and every employee of the City must abide by the terms of this policy and must report in writing any instance of the employee's own conviction under a criminal drug statute. Any such conviction must be reported to the City Human Resources Manager within five (5) days after the conviction. Upon receipt of such notification, the City shall notify the appropriate federal agency of such conviction within the time period required by law.

An employee convicted of a criminal drug offense committed in the course of employment will be subject to appropriate disciplinary action and/or required to complete successfully an appropriate rehabilitation program at the employee's own expense unless provided to the employee through insurance coverage. The City, in its sole discretion, shall determine what disciplinary action is appropriate.

Drug and Alcohol Testing:

Purpose: The purpose of this policy is to provide for the testing of employees and job applicants in conformance with the requirements of Minnesota State law.

Scope: This drug and alcohol testing policy applies to all employees of the City and to all job applicants who have received a conditional offer of employment by the City.

Definitions: For purposes of the Policy, the following definitions will apply, unless such definitions are inconsistent with applicable law. In the event of such a conflict, the terms will be given the meaning imposed by law:

- **Alcohol:** Ethyl alcohol.
- **Confirmatory Test and Confirmatory Retest:** A drug or alcohol test that uses a method of analysis authorized by Minnesota law for providing specific data as to the drugs, alcohol, or their metabolites detected in an initial screening test.

- Conviction: A finding of guilty (including a plea of guilty or "nolo contendere") or imposition of sentence, or both, by any judicial body charged with the responsibility to determine violations of state or federal
- Drug: A controlled substance as defined in applicable law.
- Drug and Alcohol Testing, Drug or Alcohol Testing, and Drug or Alcohol Test: Analysis of a body component sample in a manner consistent with Minnesota law for the purpose of measuring the presence or absence of drugs, alcohol, or their metabolites in the sample tested.
- Drug Paraphernalia: An item or items described as drug paraphernalia in Minnesota State law.
- Employee: A person, independent contractor, or person working for an independent contractor who performs services for compensation, in whatever form, for the City. "Employee" shall also mean a volunteer who provides services to the City for no or nominal compensation.
- Employer: The city of Ramsey acting through its designees of the City Council.
- Initial Screening Test: A drug or alcohol test which uses a method of analysis authorized by Minnesota law, as being capable of providing data as to general classes of drugs, alcohol, or their metabolites.
- Job Applicant: A person, independent contractor, or person working for an independent contractor who applies to become an employee of the City, and includes a person who has received a job offer made contingent on the person passing drug or alcohol testing.
- Premises: All property and locations that the City owns, is operating, or has established a presence.
- Positive Test Result: A finding of the presence of drugs, alcohol, or their metabolites in the sample tested by a confirmatory test in levels at or above the threshold detection levels established by Minnesota law. An alcohol test will be considered positive if the testee has an alcohol concentration level of at least .02 or a lesser level if it is accompanied by an odor of an alcoholic beverage or signs of physical impairment.
- Reasonable Suspicion: A belief by the Human Resources Manager or City Administrator that the appearance, behavior, speech or body odors of an employee are indicative of the use of a controlled substance or alcohol based on the observation of at least one supervisor or official who has received training in the identification of behaviors indicative of drug and alcohol use.
- Safety – Sensitive Position: A job, including any supervisory or management positions, in which an impairment caused by drug or alcohol usage would threaten the health or safety of any person.
- Under the Influence: Having the presence of a drug or alcohol at or above the level of a positive test result.

Circumstances Under which Testing may Occur: Any employee or job applicant of the City may be tested under the following circumstances:

- 1) Job Applicant: A job applicant may be requested or required to undergo drug testing after a job offer has been conditionally made and before commencing employment in the position. Alcohol testing will not be a part of a post-offer pre-employment physical examination.
- 2) Treatment Program Testing: The City may test any employee referred by the City for chemical dependency treatment or evaluation at any time and without prior notice during the period of treatment or evaluation and for up to two (2) years following completion of any prescribed chemical dependency treatment or evaluation program in accordance with Minnesota State law.
- 3) Reasonable Suspicion Testing: No employee will be tested for drugs or alcohol under this provision without the person's consent. If, however, the City asks an employee to undergo a drug or alcohol test and the employee refuses, the employee may be subject to disciplinary action, up to and including immediate termination.

The City may request or require an employee to undergo drug or alcohol testing if the employer has a reasonable suspicion that the employee:

Is under the influence of drugs or alcohol; has violated the employer's written work rules prohibiting the use, possession, sale, or transfer of drugs or alcohol while the employee is working or while the employee is on the employer's premises or operating the employer's vehicle, machinery, or equipment; has sustained or cause another person to sustain a work related personal injury; or has caused a work related accident or was operating or helping to operate machinery, equipment, or vehicle involved in a work related accident.

Random Testing and Testing without Prior Notice: Random testing may be given without prior notice during regularly scheduled work hours to those employees who are in "safety sensitive" positions including any supervisory or management positions in which an impairment caused by drug or alcohol use would threaten the health or safety of any person. Under the random selection process, there is an equal probability that an employee in a safety sensitive position subject to the selection mechanisms will be selected for testing. The City does not have discretion to waive the selection of any employee chosen on a random selection basis.

The City declares that all Fire Department positions (including but not limited to, union, non-union, supervisory and management positions) are hereby designated as "safety sensitive" positions.

The City declares that all Public Works Maintenance Division positions, (including but not limited to, union, non-union, supervisory and management positions) are hereby designated as "safety sensitive" positions.

Testing without prior notice may be conducted on employees who have been referred by the City for chemical dependency treatment or evaluation, or who are participating in a chemical dependency treatment program under an employee benefit plan, or who have participated in such a chemical dependency treatment program in the prior two years.

Criteria for Selecting Testing Laboratories: The City will only use the services of a testing laboratory that meets one or more of the criteria for drug testing or other such applicable criteria as established under Minnesota law, as amended.

Refusal to Undergo Testing:

- **Job Applicants:** Job applicants may refuse to undergo drug testing. However, if a job applicant refuses to undergo drug or alcohol testing requested or required by the employer, no such test shall be given, and the job applicant shall be deemed to have withdrawn the application for consideration for employment.
- **Employees:** Employees may refuse to undergo drug testing. However, if an employee refuses to undergo drug and alcohol testing carried out in conjunction with this Policy the employee may be subject to discipline including, but not limited to, immediate termination.

Tampering with the Urine or Blood Sample:

If an employee or job applicant tampers with his or her own urine or blood sample, or in any way deliberately causes a sample to be invalid, the employee may be subject to discipline including, but not limited to, immediate termination.

Confirmatory Testing. If a positive test is obtained, a second test will be performed on the same sample for confirmation before disciplinary action is initiated. If a sample which tests positive in the initial test and is negative in the confirming test, the employee will be reported as negative. Employees whose samples test positive in both tests shall be reported positive. An employee has the right to have a confirmed positive sample retested at the same or another City approved laboratory at the employee's own expense (approved laboratories must be in compliance with the Clinical Laboratory Improvement Act.).

In addition, upon a positive test result, an employee may show that he or she is taking a prescription drug under the supervision of a physician, or a nonprescription drug in accordance with its directions, and the positive test result will be reevaluated in light of the drug and dosage used. If such a reevaluation shows that the positive result was caused by such use of prescription or nonprescription drugs, the result will be reported as negative.

Failure to Pass Drug and/or Alcohol Testing: Employees who test positive for drugs or alcohol on a confirmatory test or confirmatory retest may be subject to discipline. Employees may be given the opportunity to go through rehabilitation following a first positive test. All discipline pursuant to this policy will be consistent with applicable law, including but not limited to, Minnesota Statutes, section 181.953 (as amended).

If a job applicant for an affected position tests positive on a confirmatory test for drugs, any offer of employment will be withdrawn and the individual will not be considered for employment by the City. If a positive confirmatory test is caused by the lawful use of a drug prescribed for the job applicant or an over-the-counter substance consumed in accordance with instructions, the City will not withdraw a job offer. However, a job offer will be withdrawn if an applicant is not reasonably able to perform the assigned duties of the position.

Rights of Employee or Job Applicant:

An employee or job applicant who receives a positive test result on a Confirmatory Test has the right to receive a copy of the test result report and, within three (3) working days of notice of the original positive Confirmatory Test result, to submit information to the City in addition to any information already submitted to explain that result, or within five (5) working days to notify the City in writing of the employee's intention to obtain a Confirmatory Retest of the original sample at the employee's or job applicant's own expense.

If the Confirmatory Retest is conducted in accordance with rules established by the Commissioner of the Minnesota Department of Health by a qualified laboratory, and if it is not positive, the City shall reimburse the employee or job applicant for the actual cost of the Confirmatory Retest in an amount not to exceed \$100.00 and no adverse personnel action shall be taken against the employee or job applicant based on the original Confirmatory Test.

General Testing Procedures:

All testing will be performed by a licensed laboratory that certifies its compliance with the requirements of Minnesota State law. When the City decides to test for drug or alcohol use on any of the grounds enumerated in Section 4 the following procedures will apply:

Initial Screening Test: Acknowledgement. Before the Initial Screening Test, the employee or job applicant shall be informed of the City's testing policy and given a form on which the employee or job applicant can acknowledge being so informed.

If the Initial Screening Test produces a negative result, written notice of such result will be given to the individual who took the test within three (3) working days after the City receives the test result report. The employee or applicant will also be notified that they have the right to request and receive a copy of the test report.

The testing laboratory will perform a Confirmatory Test on all samples that produce a positive test result on the Initial Screening Test.

Confirmatory Test. If the Initial Screening Test produces a positive test result, a second test (known as the Confirmatory Test) will be conducted by the laboratory. If the Confirmatory Test is not positive, the City will send written notice of this fact to the employee or job applicant within three (3) working days after receiving the result.

If the Confirmatory Test produces a positive test result, the City will take the following four steps: (1) The City will send written notice of the positive test result within three working days after receiving it to the employee or job applicant. (2) The employee or job applicant will be informed of the right to receive a copy of the test result. (3) The employee or job applicant will be told of the right to explain the positive result by indicating any medication (prescription, signed for, or over-the-counter) that the individual is currently taking or has recently taken and other information relevant to the reliability of or explanation for a confirmatory positive test result. (4) The employee or job applicant will be informed of the right to request a Confirmatory Retest of the

original sample at the employee's or job applicant's expense. The employee or job applicant has five working days in which to notify the City of this request in writing.

Confirmatory Retests: After an employee or job applicant chooses to request a Confirmatory Retest, the employee or job applicant has five (5) working days within which to notify the City of this request in writing. Within three (3) days of the receipt of such request, the City will notify the original testing laboratory that it is to conduct a Confirmatory Retest or transfer the sample to another certified laboratory for retesting. If the Confirmatory Retest does not confirm the original positive test result, no adverse personnel action will be taken by the City. If the Confirmatory Retest is positive, the City may withdraw its conditional offer of employment to a job applicant or terminate an employee if such employee chooses not to participate in a chemical dependency treatment or evaluation program.

Data Privacy:

Test result reports and other information acquired in the drug and alcohol testing process are private data on individuals as defined in Minnesota law, and may not be disclosed to another employer or to a third party individual, governmental agency, or private organization without the written consent of the employee or applicant tested, unless otherwise permitted by law or required by court order.

Other Misconduct:

Nothing in this Policy limits the right of the City to discipline or discharge an employee on grounds other than a positive test result in a Confirmatory Test. For example, possession, observed consumption of a controlled substance, the sale of a controlled substance on City premises, or conviction under any criminal drug statute for a violation occurring in the workplace, may by themselves, be grounds for discipline or discharge. Any City employee may be subject to discipline up to and including termination for violation of this Policy or any rules adopted by the City with respect to the manufacture, use, sale, or transfer of drugs and alcohol.

Administrative Responsibility:

The City Administrator, or his or her designees, shall be responsible for implementing this Policy. Each Department Head and supervisor shall be responsible for informing their employees of this Policy. Each employee of the City shall be notified of this Policy. Employees shall acknowledge, in writing, receipt of this Policy.

Collective Bargaining Unit Conflict:

Nothing set forth in this Drug Free Workplace Policy is intended to conflict or interfere with the terms of a collective bargaining agreement, if any, between the City and its employees.

Employee Assistance Program: The City contracts with an outside Employee Assistance Program (E.A.P.) to provide free, confidential assessment and referral services for any number of personal problems including drug and alcohol abuse and misuse. Employees are encouraged to use this service to obtain assistance for themselves or family members. To obtain more information, contact Human Resources.

SECTION 13 ACKNOWLEDGEMENT OF RECEIPT OF THE PERSONNEL POLICY

I acknowledge that I have received a copy of the city of Ramsey Personnel Policy. I understand that this document contains important information regarding the City's general personnel policies and my privileges and obligations as an employee. I will familiarize myself with the personnel policy and I understand that I am governed by its contents. I further understand that the personnel policy is not an employment contract and that the City may change, rescind or add to any policies, benefits, or practices at its sole discretion with or without prior notice.

Employee's Signature

Date

Employee's Name (typed or printed)

Witness' Signature

Date

Witness' Name (typed or printed)

CC Work Session

2. 4.

Meeting Date: 02/12/2018

Submitted For: Patrick Brama, Administrative Services

By: Patrick Brama, Administrative Services

Information

Title:

Pricing Strategy (portions of this case may be closed to the public)

Purpose/Background:

Purpose:

Review pricing strategy for the sale of city owned land.*

*The pricing strategy discussion will occur during closed session. Staff will be sending confidential materials to the Council directly, via email. The attached reference map shows the various properties currently available for sale/ purchase. Although CBRE is the City's broker, for various reasons, they are not listing all available City owned properties. Staff has received EDA input on the proposed/ updated pricing strategy and wants to share this information with the Council in a closed session to address any questions.

Notification:

NA

Observations/Alternatives:

The pricing strategy is used by staff as a guide for real estate negotiations. The Council ultimately approves all land sales by separate action.

Funding Source:

NA

Recommendation:

NA

Action:

No action necessary. Informational only.

Attachments

Ref Map

Current CBRE Listings

Shovel Ready Status Tables (draft)

Form Review

Inbox

Kurt Ulrich

Form Started By: Patrick Brama

Final Approval Date: 02/08/2018

Reviewed By

Kurt Ulrich

Date

02/08/2018 02:55 PM

Started On: 01/11/2018 01:44 PM

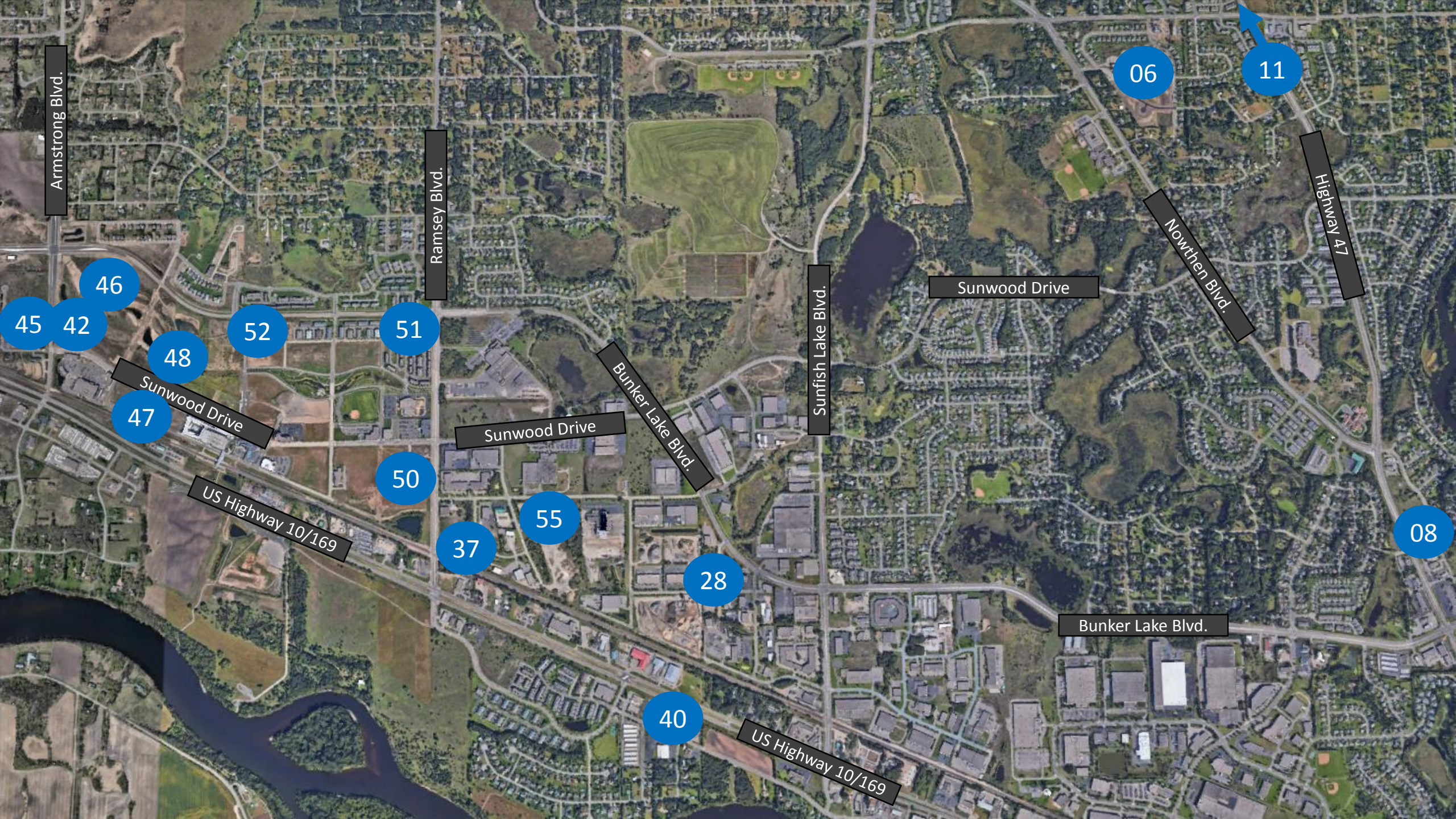

Armstrong Blvd.

Ramsey Blvd.

Sunfish Lake Blvd.

Highway 47

Nowthen Blvd.

Sunwood Drive

Sunwood Drive

Bunker Lake Blvd.

Bunker Lake Blvd.

US Highway 10/169

US Highway 10/169

Sunwood Drive

37

55

28

40

46

45

42

48

47

52

50

51

06

11

08

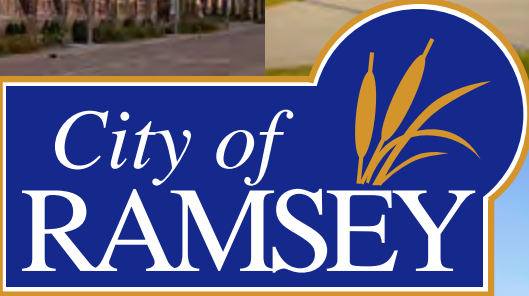

TABLE OF CONTENTS

EXECUTIVE SUMMARY.....3

PARCEL LISTINGS.....4

CITY OF RAMSEY.....5

THE COR.....11

HWY 10/ARSMSTONG BLVD REALIGNMENT.....15

NORTHSTAR COMMUTER RAIL.....16

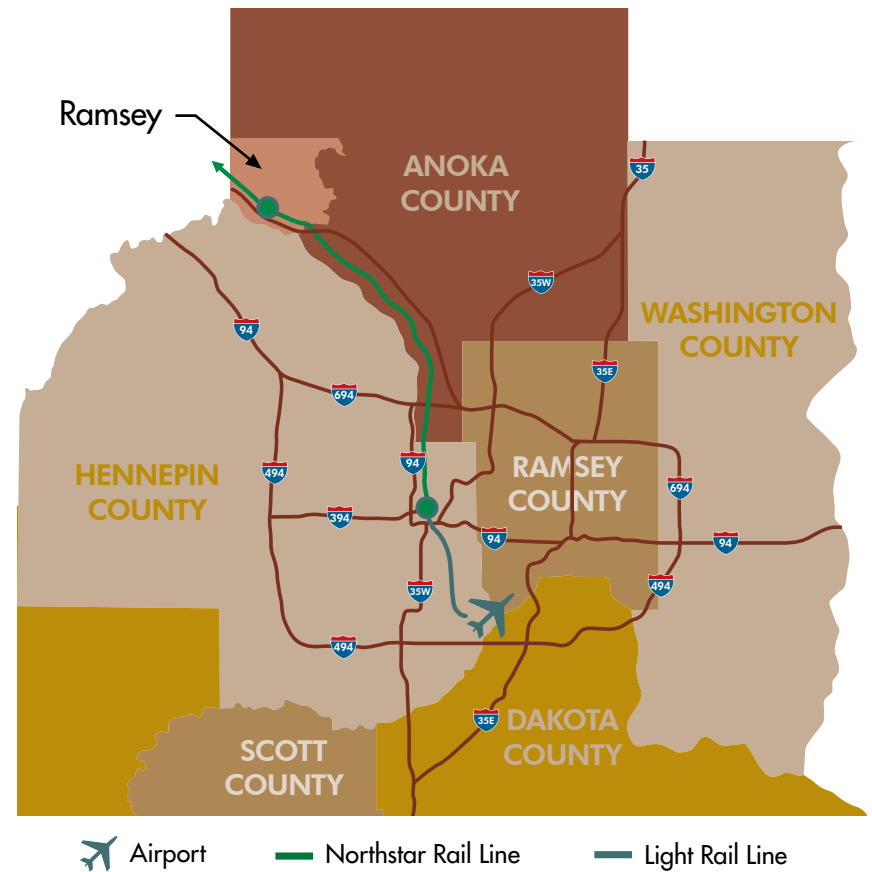

DISCLAIMER
 © 2016 CBRE, Inc. The information contained in this document has been obtained from sources believed reliable. While CBRE, Inc. does not doubt its accuracy, CBRE, Inc. has not verified it and makes no guarantee, warranty or representation about it. It is your responsibility to independently confirm its accuracy and completeness. Any projections, opinions, assumptions or estimates used are for example only and do not represent the current or future performance of the property. The value of this transaction to you depends on tax and other factors which should be evaluated by your tax, financial and legal advisors. You and your advisors should conduct a careful, independent investigation of the property to determine to your satisfaction the suitability of the property for your needs.

EXECUTIVE SUMMARY

CITY OF RAMSEY OVERVIEW

Ramsey is a northwestern Twin Cities suburb in Anoka County with an estimated 2015 population of 25,580., and is the second-fastest growing city in Anoka County. It is 28 square miles with 15% wetlands, 565 acres park and open space, and bordered by the Rum and Mississippi Rivers. The City is also known for its unique COR development that encompasses over 400 acres of residential, commercial, retail, educational and recreational uses. The COR is the Twin Cities' first and only mixed-use development on the Northstar Commuter Line that services downtown Minneapolis, and offers a unique transit oriented development providing easy access to home, work, and neighborhood services. Highways 10/169 and 47 are two larger transportation routes.

As of the census of 2010, there were 23,668 people, 8,033 households, and 6,484 families residing in the city of Ramsey. The population density was 821.5 inhabitants per square mile (317.2/km²). There were 8,302 housing units at an average density of 288.2 per square mile (111.3/km²).

There were 8,033 households of which 43.9% had children under the age of 18 living with them, 67.6% were married couples living together, 8.5% had a female householder with no husband present, 4.6% had a male householder with no wife present, and 19.3% were non-families. 13.7% of all households were made up of individuals and 3% had someone living alone who was 65 years of age or older. The average household size was 2.95 and the average family size was 3.24.

The median age in the city was 34.9 years. 28.7% of residents were under the age of 18; 7.8% were between the ages of 18 and 24; 29.4% were from 25 to 44; 27.4% were from 45 to 64; and 6.7% were 65 years of age or older. The gender makeup of the city was 50.3% male and 49.7% female

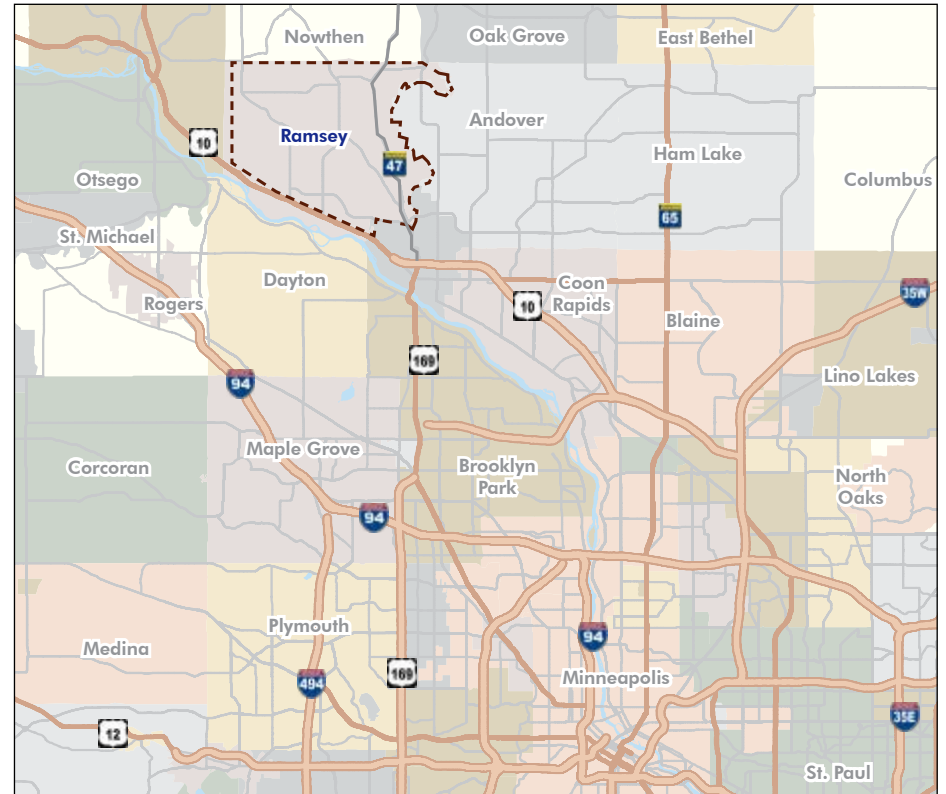

30 minutes to Downtown Minneapolis (±22 miles)

DEMOGRAPHICS, LIVABILITY, WORKFORCE

- 2015 Population 25,580
- Median Household Income: \$83,115
- Anoka County Labor Force: 194,170
- Manufacturing hub: 33% of businesses in Ramsey; second highest percentage in Anoka County
- Nearly 1,300 businesses & non-profit organizations; more than 6,000 jobs
- Top Minneapolis Suburb for young couples (movoto.com, 2015)
- Home to the Game Fair, The Draw Event Series, and Happy Days
- 565 acres of parkland and extensive trail system
- 15% of Ramsey is protected wetland

PARCEL LISTINGS

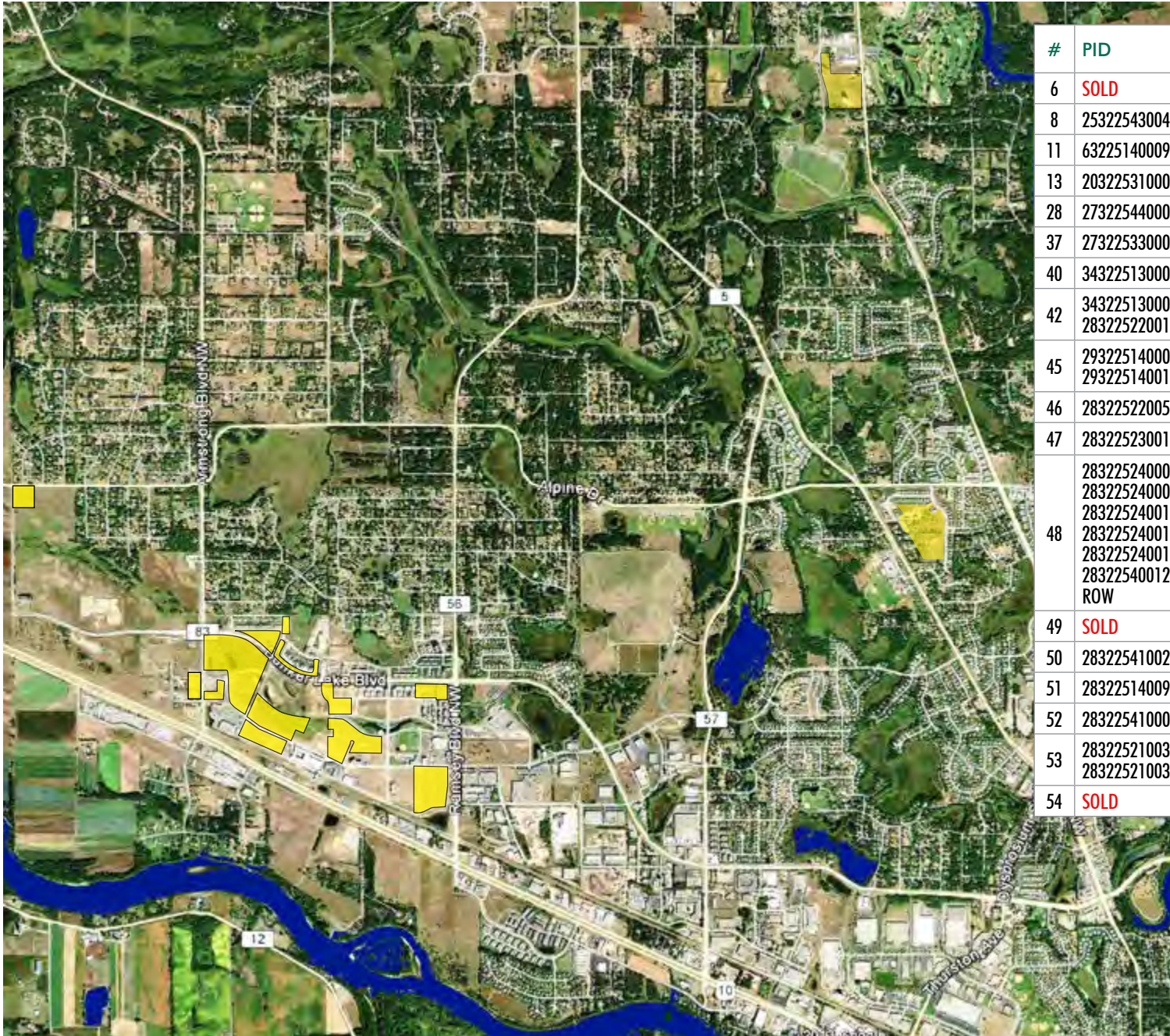

#	PID	ACRES	LAND USE	LIST PRICE
6	SOLD			
8	253225430043	1.01	Commercial	\$153,985
11	63225140009	6.75	Residential	\$256,800
13	203225310003	4.11	Residential	\$164,000
28	273225440003	0.95	Commercial	\$82,764
37	273225330006	4.14	Office	\$450,000
40	343225130005	1.23	Commercial	\$215,000
42	343225130005 283225220013	2.61	Commercial	\$1,365,000/\$12 PSF
45	293225140009 293225140010	2.88	Mixed	\$10/SF
46	283225220058	30.9	Commercial	\$6,730,000
47	283225230010	4.94	Mixed	\$1,075,932/\$5 PSF
48	283225240009 283225240009 283225240011 283225240010 283225240013 283225240012 ROW	20.00	Mixed	\$3,485,000
49	SOLD			
50	283225410020	13.34	Commercial	From \$6 PSF
51	283225140094	4.30	Residential	\$350,000
52	283225410009	4.96	Residential	\$450,000
53	283225210035 283225210030	7.38	Residential	\$210,000
54	SOLD			

Click on any numbered box to open the brochure for that parcel

THE CITY OF RAMSEY - FACTS

OVERVIEW

- Second-fastest growing City in Anoka County
- U.S. HWY 10, State Highway 169, State Highway 47 and Northstar Commuter Rail (linking to MSP) access
- Manufacturing hub (33% of businesses in Ramsey)
- Relevant, nearby, educational opportunities and workforce for manufacturing businesses
- Home to The COR, a new urban downtown development with direct access to the Northstar Commuter Rail
- Bordered by the Mississippi River, Rum River and Trott Brook, Ramsey is one of Minnesota's premier places to live

EDUCATION

- **Over 50 universities located** - within 50 miles
- **Anoka Technical College** - within 1 mile
- **PACT Charter School** - located on Ramsey Blvd & E Ramsey Pkwy, 600 current students and 2,000 on waiting list

HIGHLIGHTS

- **Coborn's Grocery Store** - anchors approximately 100,000 SF of retail in The COR and provides full service grocery, liquor, fuel and pharmacy.
- Northstar Station
- VA Clinic
- US Highway 10 - highest traveled road in the state
 - Ramsey Blvd @ Hwy 10: 44,000 VPD
 - Armstrong Blvd @ Hwy 10: 39,000 VPD

CITY and COUNTY CONTACTS

Kurt Ulrich

City Administrator
763 433 9845
kulrich@ci.ramsey.mn.us

Patrick Brama

Economic Development Manager
763 433 9868
pbrama@cityoframsey.com

Tim Gladhill

Community Development Director
763 433 9826
tgladhill@cityoframsey.com



www.ci.ramsey.mn.us

THE CITY OF RAMSEY - CONSTRUCTION & HOUSING



THE CITY OF RAMSEY - CONSTRUCTION & HOUSING

RESIDENTIAL DEVELOPMENT PATTERNS

2012, 295 total housing units

Single Family, 57 units

Townhomes, 8 units

Multi Family, 230 units

2013, 234 total housing units

Single Family, 96 units

Townhomes, 66 units

Multi Family, 72 units

2014, 66 total housing units

Single Family, 66 units

Townhomes, 0 units

Multi Family, 0 units

2015, 290 total housing units

Single Family, 83 units

Townhomes, 39 units

Multi Family, 168 units



MAJOR ACTIVE DEVELOPMENTS

- Single-family Construction – GS Land/ Harvest Estates PLAT, up to 44 lots located in east central Ramsey.
- Single-family Construction –Lennar Homes/ Woodlands PLAT, up to 85 lots located in central Ramsey.
- Townhome Construction –D.R. Horton/ The Station PLAT, up to 77 units located in The COR.



THE CITY OF RAMSEY - BUSINESS GROWTH

MANUFACTURING HOT SPOT

- Vision Ease Lens
- Diamond Graphics Printing
- Life Fitness
- Connexus Energy
- Cullinan Rigging & Erecting
- Ace Solid Waste

LABOR MARKET

- Anoka County Labor Force: 194,170
- Over 600 existing businesses and non-profit organizations in Ramsey
- **VA Clinic** - Opened in November 2011, the facility provides critical services to over 30,000 of our most honored citizens
- **Allina Clinic** - 30,000 square foot facility is the newest prototype in the Allina program featuring dominant architectural features; the general medicine facility also includes a sports medicine component

LARGEST EMPLOYERS	EMPLOYEES
Life Fitness	457
Vision Ease Lens	349
Connexus Energy	250
Anderson Dahlen Inc.	175
Zero Zone Inc.	174

BUSINESS PARKS

The City of Ramsey is proud to be a pro-economic development community. This is not only demonstrated by a rich history of successfully developing business parks, it is demonstrated by the commitment to the future of economic development within the community. The City has placed an emphasis on encouraging economic development within the Council strategic plans, EDA workplans, and Comprehensive Plan.

Both the City of Ramsey and the City of Anoka share a large business park spanning across 1,000 acres of land. This business park includes various office, warehouse, assembly, and a wide-variety of manufacturing users. Nearly 10,000 jobs have been created by this business park. The City of Ramsey and Anoka share a major economic engine that serves not only the Twin Cities, but also the national and global market place.

The City of Ramsey will consider moving forward with a new 93-acre greenfield business park located just northwest of the new full-access grade-separated Armstrong Boulevard/U.S. Highway 10 Interchange in April 2016. The new business park has 25 acres of land shovel-ready today.



THE CITY OF RAMSEY - DEMOGRAPHICS

CBRE DEMOGRAPHIC BRIEF

RAMSEY CITY CENTER

	1 Mile	3 Miles	5 Miles	10 Miles
POPULATION				
2016 Population	2,493	23,952	50,866	252,652
2021 Population	2,679	25,575	53,433	265,483
2010 Population	2,259	21,908	47,789	236,800
2000 Population	1,933	16,998	40,581	200,404
Percent Pop Change: 2010 to 2016	10.4%	9.3%	6.4%	6.7%
Percent Pop Change: 2016 to 2021	7.5%	6.8%	5.1%	5.1%
AGE				
2016 Median Age	37.7	37.0	37.8	37.9
2016 Average Age	37.5	36.6	37.5	37.5
HOUSEHOLDS				
2016 Households	891	8,094	18,110	90,502
2021 Households	969	8,687	19,114	95,240
2010 Households	784	7,368	16,897	84,665
2000 Households	626	5,373	13,501	68,453
Percent HH Change: 2010 to 2016	13.5%	9.9%	7.2%	6.9%
Percent HH Change: 2016 to 2021	8.8%	7.3%	5.5%	5.2%
Average Household Size	2.8	2.9	2.8	2.8
INCOME				
2016 Median Household Income	\$78,781	\$83,624	\$79,169	\$78,267
2016 Average Household Income	\$87,403	\$95,434	\$91,266	\$92,347
2016 Per Capita Income	\$31,224	\$32,251	\$32,494	\$33,079
HOUSING UNITS				
2016 Housing Units	915	8,341	18,757	94,083
2016 Occupied Housing Units	891	8,094	18,110	90,502
2016 Vacant Housing Units	24	247	647	3,580
2016 Owner-Occupied Housing Units	843	7,420	15,525	75,960
2016 Renter-Occupied Housing Units	48	674	2,585	14,542
EDUCATION				
2016 Population Age 25 and Over	1,667	15,545	33,618	166,878
High School thru Associates	1,144 68.6%	10,387 66.8%	22,454 66.8%	107,522 64.4%
Bachelor's Degree	301 18.1%	3,238 20.8%	6,816 20.3%	36,265 21.7%
Graduate Degree	105 6.3%	1,075 6.9%	2,366 7.0%	14,266 8.5%
PLACE OF WORK				
Total Businesses	27	627	1,564	8,672
Daytime Employment (Total Employees)	65	6,154	15,654	100,660

CBRE DEMOGRAPHIC BRIEF

RAMSEY CITY CENTER



©2016 CBRE. This information has been obtained from sources believed reliable. We have not verified it and make no guarantee, warranty or representation about it. Any projections, opinions, assumptions or estimates used are for example only and do not represent the current or future performance of the property. You and your advisors should conduct a careful, independent investigation of the property to determine to your satisfaction the suitability of the property for your needs. Source: Nielsen Page 1 ProjectID:81390

NAME	LATITUDE	LONGITUDE
1 RAMSEY CITY CENTER	45.2611	-93.45

THE CITY OF RAMSEY - EDA FINANCING TOOLS

The City of Ramsey has a number of financial tools available for economic development projects. Below is an overview of common economic development tools.

GAP FINANCING

- Ramsey Revolving Loan Fund (RLF)
- Minnesota Investment Fund (MIF)

SBA FINANCING

- Small Business Administration (SBA) Loans
- Small Business Administration (SBA) Loan Guarantees

PROPERTY TAX PROGRAMS

- Tax Abatement
- Tax Increment Financing (TIF)

PRIMARY FINANCING

- Private Primary Lending Lender and/or Owner Equity (no involvement from city)
- Industrial Revenue Bonds (IRB)



DISCLOSURE

Eligibility for financing tools is based on the merit of an individual project, compliance with specific program requirements and in many cases approval from the Ramsey EDA and City Council. The City of Ramsey targets quality projects with high quality job growth. Typically, projects will require owner equity and/or private financing.

THE CITY OF RAMSEY - THE COR

THE COR

The COR (Center of Ramsey) is the City of Ramsey's downtown development. This 400 acre development is a true, transit oriented and walkable, urban development. The COR is centered on U.S. Highway 10/ U.S. Highway 169 and the Northstar Rail (Ramsey Station). This mixed use development is home to a long list of successful projects including residential, retail, office, recreation, government facilities, and much more!

The COR, known formerly as Ramsey Town Center, was purchased by the City of Ramsey in 2009. About 130 acres of land is available for development in The COR today; about 90 acres is City-owned. Located directly adjacent to The COR is 90 acres of additional land available for commercial (retail) development.

RECENT MAJOR ACTIVITY

1. Rental apartments – 121 units of market rate apartments being developed by PSD LLC in The COR, near The Draw Park and Amphitheatre. Construction is underway, completion is anticipated for winter 2016.
2. Rental apartments - 47 units of workforce housing being developed by Common Bond Communities in The COR, near The Ramsey Northstar Commuter Rail Station. Construction is underway, completion is anticipated for fall 2016.
3. Casey's Convenience Store – 4,500 square foot convenience retail store completed by Casey's Retail Company, near Ramsey Boulevard/ Sunwood Drive. Construction is completed, operations began in January of 2016.
4. Quick Service Restaurant – 4,500 square foot restaurant to be developed by McDonald's USA LLC in The COR, near the new Armstrong Interchange. Construction anticipated for completion in 2017.





5. Armstrong Blvd Interchange – new full-access grade-separated interchange, intersection of U.S. Highway 10 and Armstrong Boulevard. Final completion set for summer 2016.
6. Townhomes – 15 units of town homes completed in 2016, 77 additional units under review for platting by D.R. Horton within The COR, near The Draw Park & Amphitheatre.
7. Renovation – Coborn's completed a half-million dollar remodel and upgrade to their convenience and liquor spaces in late 2015. Coborn's is 60,000 square

PRE-2015 COR PROJECTS INCLUDE:

- 95,000 square foot Coborn's anchored multi-tenant retail center, over 90% occupancy
- PACT Charter School (K-12)
- Ramsey Municipal Center (60,000 square feet)
- Veterans Affairs Outpatient Clinic (40,000 square feet)
- Ramsey Office Plaza (80,000 square feet), over 90% occupancy
- Midwest Medical Examiner's Office
- NAU County Insurance Office (42,000 square feet)
- Northgate Church & Community Performing Arts Center (500 seats)
- Allina Medical Clinic (25,000 square feet)
- 230-unit luxury apartment complex (Residence at The COR)
- \$3M The Draw park & amphitheater
- Ramsey Rail Station: connected to covered 800 stall parking ramp by skyway with service to Minneapolis
- Various single family and townhome developments totaling several hundred households



COR CONCEPT PLAN

	Commercial
	Office
	Public/Institutional
	Residential
	Mixed Use

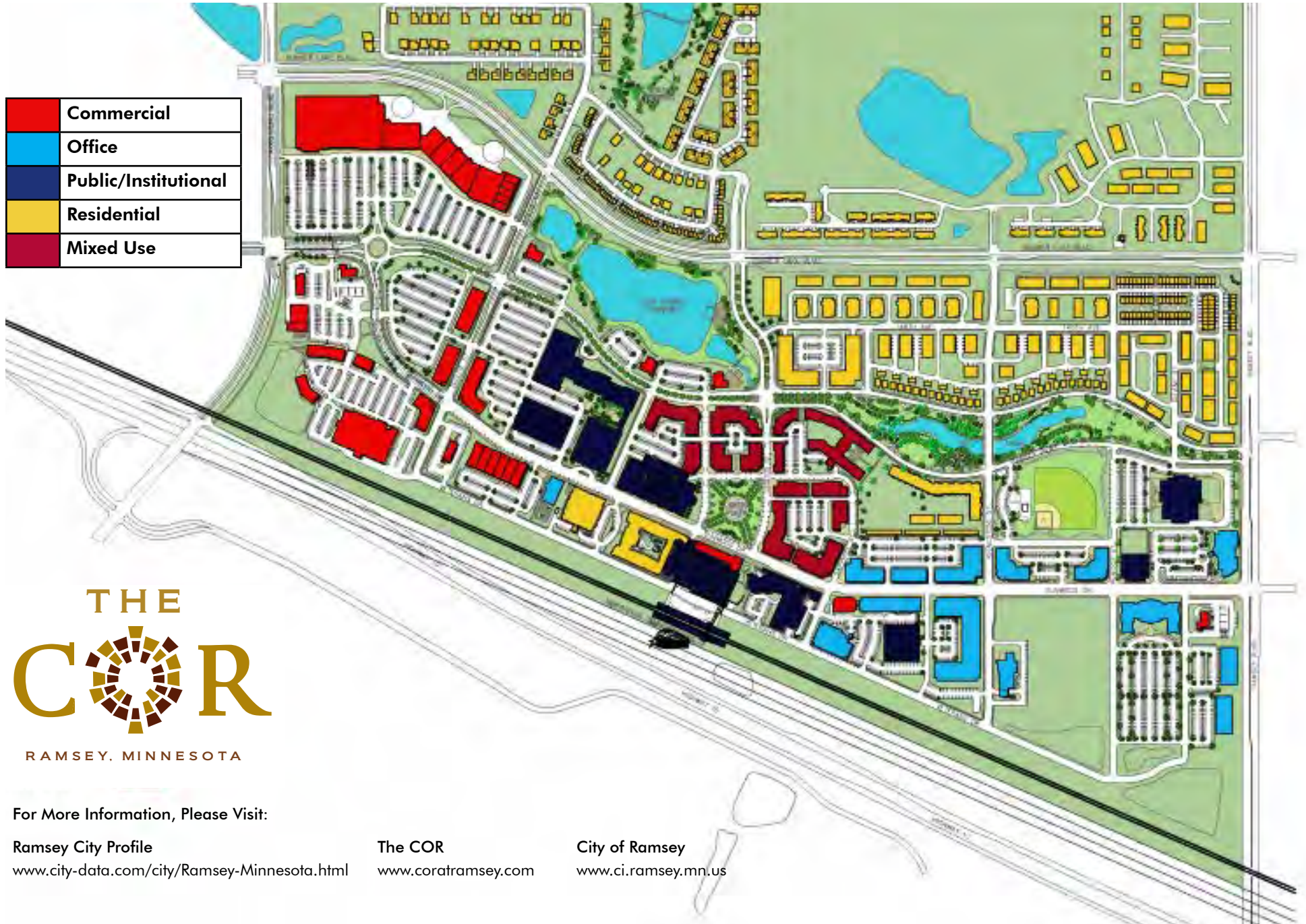

THE
COR
RAMSEY, MINNESOTA

For More Information, Please Visit:

Ramsey City Profile
www.city-data.com/city/Ramsey-Minnesota.html

The COR
www.coratramsey.com

City of Ramsey
www.ci.ramsey.mn.us

COR - AVAILABLE PARCELS

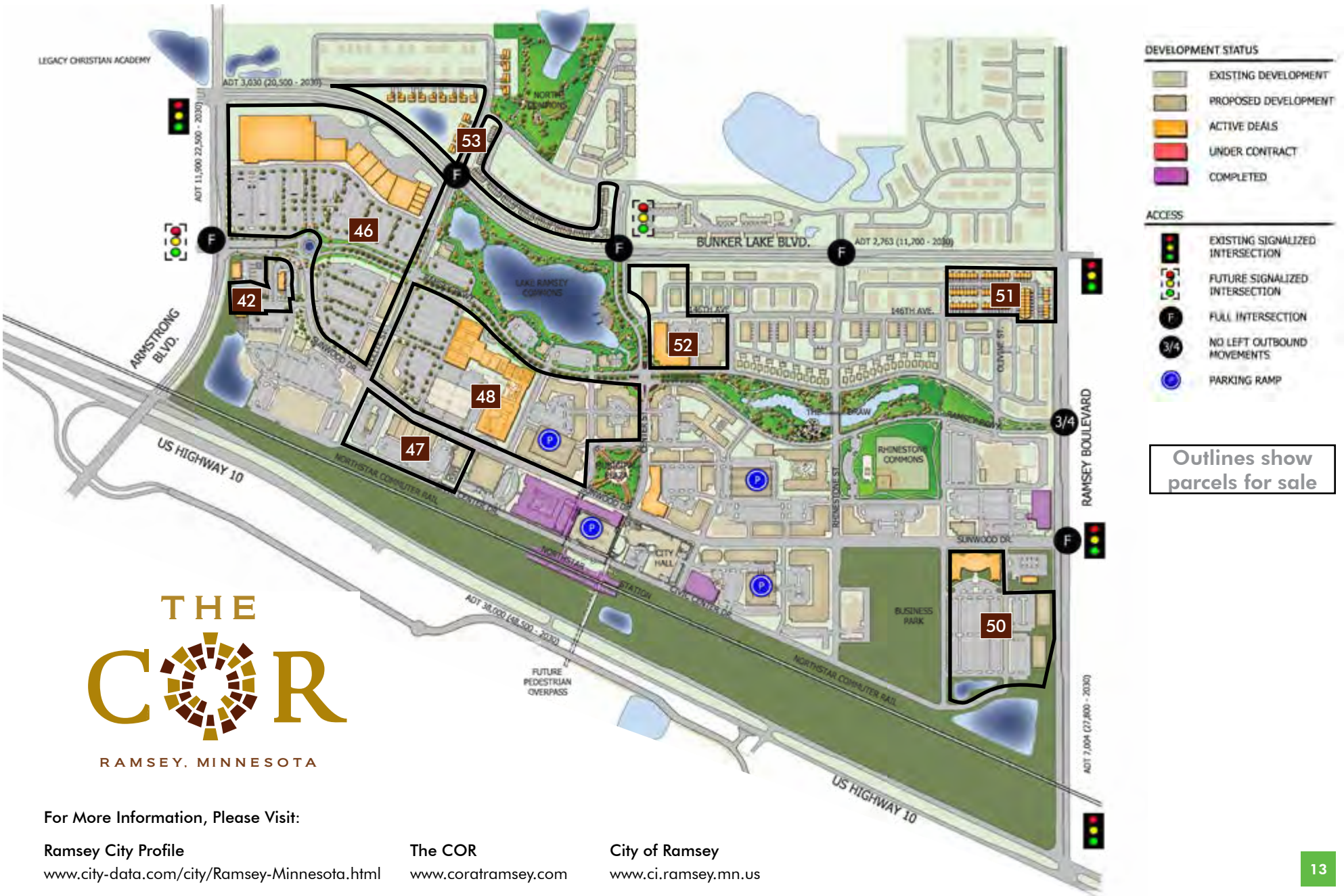

For More Information, Please Visit:

Ramsey City Profile
www.city-data.com/city/Ramsey-Minnesota.html

The COR
www.coratramsey.com

City of Ramsey
www.ci.ramsey.mn.us

HWY 10/ARMSTRONG BLVD REALIGNMENT

NEW FULL ACCESS INTERCHANGE - COMPLETED 2015/2016



ROAD CONSTRUCTION TIMING

Construction of the Armstrong Interchange has been completed. Additionally, there is a large Hwy 10 Access Planning Study under way to improve the safety and flow of Hwy 10. Hwy 10 is already a tremendous asset to the community but its positive impact will continue to grow with improvements to the corridor between Anoka, Ramsey and Elk River.

NORTHSTAR COMMUTER RAIL

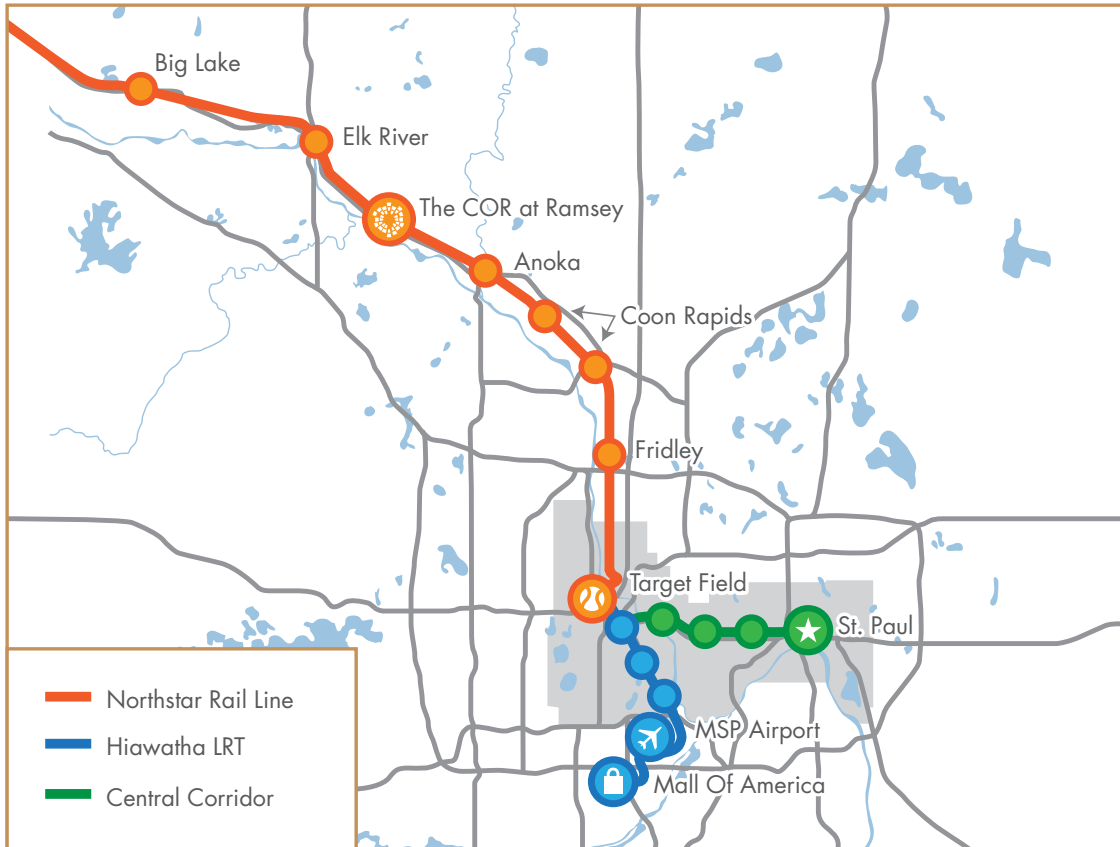

STATION SPOTLIGHTS

The Ramsey Rail Station is now open and is the newest stop on the Northstar Commuter Rail. With safe, convenient, affordable and reliable transportation to downtown Minneapolis, and connections to the Airport and Mall of America, this regional transit solution is a critical part of the transit services provided in The COR. It's the only station connected by skyway to a public parking ramp and is located in the center of The COR, Ramsey's new downtown development.



DAILY RIDERSHIP
AVERAGES 2,539 RIDERS
PER DAY WITH A TARGET
OF 5,900 RIDERS PER
DAY BY 2030.

The \$13 million Ramsey Station investment is leveraging \$80 million in residential, retail and other investments in The COR. Rail service has also sparked new development around the station area, including the new Veterans Administration Clinic, Allina Medical Clinic, Falls Café, and Legacy Christian Academy.

Outside of downtown Minneapolis, seven stations are located along the 40-mile corridor: Target Field in Minneapolis, Fridley, Coon Rapids/Riverdale, Anoka, Ramsey, Elk River, and Big Lake. Another 3 stations are proposed in St. Cloud, Becker and Coon Rapids/Foley.

For More Information, Please Contact:

Richard Palmiter

Vice President

+1 952 924 4603

richard.palmiter@cbre.com

Brian Pankratz

Vice President

+1 952 924 4665

brian.pankratz@cbre.com

For More Information, Please Visit:

Ramsey City Profile

www.city-data.com/city/Ramsey-Minnesota.html

Northstar Commuter Rail Line

www.metrotransit.org/northstar

The COR

www.coratramsey.com

City of Ramsey

www.ci.ramsey.mn.us

AFFILIATED BUSINESS DISCLOSURE

CBRE, Inc. operates within a global family of companies with many subsidiaries and/or related entities (each an "Affiliate") engaging in a broad range of commercial real estate businesses including, but not limited to, brokerage services, property and facilities management, valuation, investment fund management and development. At times different Affiliates may represent various clients with competing interests in the same transaction. For example, this Memorandum may be received by our Affiliates, including CBRE Investors, Inc. or Trammell Crow Company. Those, or other, Affiliates may express an interest in the property described in this Memorandum (the "Property") may submit an offer to purchase the Property and may be the successful bidder for the Property. You hereby acknowledge that possibility and agree that neither CBRE, Inc. nor any involved Affiliate will have any obligation to disclose to you the involvement of any Affiliate in the sale or purchase of the Property. In all instances, however, CBRE, Inc. will act in the best interest of the client(s) it represents in the transaction described in this Memorandum and will not act in concert with or otherwise conduct its business in a way that benefits any Affiliate to the detriment of any other offeror or prospective offeror, but rather will conduct its business in a manner consistent with the law and any fiduciary duties owed to the client(s) it represents in the transaction described in this Memorandum.

CONFIDENTIALITY AGREEMENT

This is a confidential Memorandum intended solely for your limited use and benefit in determining whether you desire to express further interest in the acquisition of the Property.

This Memorandum contains selected information pertaining to the Property and does not purport to be a representation of the state of affairs of the Property or the owner of the Property (the "Owner"), to be all-inclusive or to contain all or part of the information which prospective investors may require to evaluate a purchase of real property. All financial projections and information are provided for general reference purposes only and are based on assumptions relating to the general economy, market conditions, competition and other factors beyond the control of the Owner and CBRE, Inc. Therefore, all projections, assumptions and other information provided and made herein are subject to material variation. All references to acreages, square footages, and other measurements are approximations. Additional information and an opportunity to inspect the Property will be made available to interested and qualified prospective purchasers. In this Memorandum, certain documents, including leases and other materials, are described in summary form. These summaries do not purport to be complete nor necessarily accurate descriptions of the full agreements referenced. Interested parties are expected to review all such summaries and other documents of whatever nature independently and not rely on the contents of this Memorandum in any manner.

Neither the Owner or CBRE, Inc. nor any of their respective directors, officers, Affiliates or representatives make any representation or warranty, expressed or implied, as to the accuracy or completeness of this Memorandum or any of its contents, and no legal commitment or obligation shall arise by reason of your receipt of this Memorandum or use of its contents; and you are to rely solely on your investigations and inspections of the Property in evaluating a possible purchase of the real property.

The Owner expressly reserved the right, at its sole discretion, to reject any or all expressions of interest or offers to purchase the Property, and/or to terminate discussions with any entity at any time with or without notice which may arise as a result of review of this Memorandum. The Owner shall have no legal commitment or obligation to any entity reviewing this Memorandum or making an offer to purchase the Property unless and until written agreement(s) for the purchase of the Property have been fully executed, delivered and approved by the Owner and any conditions to the Owner's obligations therein have been satisfied or waived.

By receipt of this Memorandum, you agree that this Memorandum and its contents are of a confidential nature, that you will hold and treat it in the strictest confidence and that you will not disclose this Memorandum or any of its contents to any other entity without the prior written authorization of the Owner or CBRE, Inc. You also agree that you will not use this Memorandum or any of its contents in any manner detrimental to the interest of the Owner or CBRE, Inc.

If after reviewing this Memorandum, you have no further interest in purchasing the Property, kindly return this Memorandum to CBRE, Inc.

CBRE

Site #06

Former Municipal Center Site
Lot 25 Block 1 Harvest Estates

PID [23-32-25-41-0081](#)

Size 6.41 acres
R1 Residential



Shovel Ready Status

1	MN Formal Shovel Ready Application	✓*	*Done, 2013. Was originally completed for a potential data center redevelopment. May be considered outdated.
2	Title Work	✓✓	Done, 2013.
3	ALTA Survey	✓✓	Done, 2013. Update probably not needed, original should suffice.
4	Public Utility Locations and Specs (water, sewer, storm)	✓✓	Done, 2013. Some changes have occurred. Utilities adjacent.
5	Private Utility Locations and Specs (elec, gas, tele).	✓✓	Done, 2013. Some changes have occurred. Utilities adjacent.
6	Geotechnical Soils Evaluation	✓✓*	Done, 2013. Some changes have occurred. Significant fill needed for Phase II.
7	Phase I ESA	✓✓	Done, 2013. Phase II was warranted.
8	Additional ESAs or Environmental Reports	✓✓*	*Done, 2013. Phase II ESA, Response Action Plan, Closure Letter, Hazardous Materials Survey were completed.
9	National Wetland Inventory and Flood Plain Maps		Do not have on file. Technically not part of MN Formal Shovel Ready application.
10	Site Photos and Site Specs	✓✓	Outdated, some changes have occurred. Updated probably not needed, original should suffice.
11	Community Profile	✓✓	Done, 2017.
12	Other Items Cut/ fill, topography, traffic counts, tree inventory, development fees status, subdivision required, public infrastructure status, concept maps, cost-shares, assessments, encumbrances, etc.		Site currently subject to a purchase agreement with GS Land. Closing is set for summer 2018. City still needs to decide how to deal with access to Nowthen. The City owns the land the current access point is located (from Nowthen). That access point is also the location of utility services that support this site. The City has talked about using this property as open space, for a small pocket park, or at a minimum a trail corridor for this neighborhood to get to Nowthen. City was to decide during entitlement process for this project. Staff believes this phase will require a significant amount of fill. Staff would note, if the developer doesn't close on phase II, they will need to construct a permanent cul-de-sac to serve their phase I development (currently a temp cul-de-sac in place today). This site was previously home to a municipal center campus. Was demolished in 2016-2017. Will need to re-route utility line.

Site #08

Former Amoco Gas Station
 Lot 1 Block 1 Rivers Bend Plaza
 PID [25-32-25-43-0043](#)
 Size 1.01 acres
 Commercial/ Retail

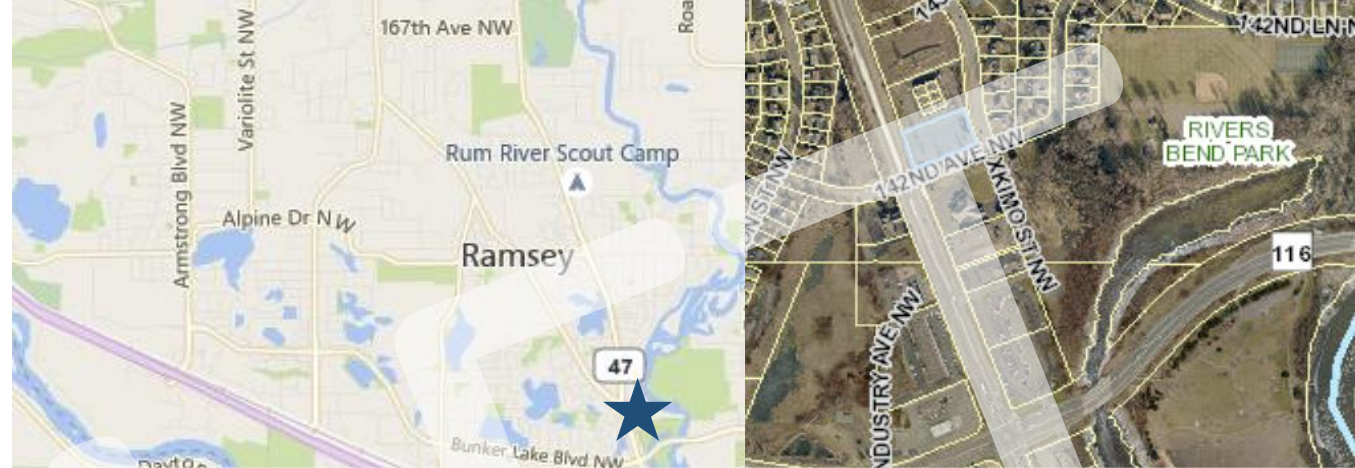

Shovel Ready Status

1	MN Formal Shovel Ready Application		Not completed. Sale price too small to justify the investment.
2	Title Work	✓*	*Done, 2011. Previous owner has encumbrance.
3	ALTA Survey		Do not have on file. Can use old plat as starting point now. Staff should order this.
4	Public Utility Locations and Specs (water, sewer, storm)		Staff can flip this fairly quick if a user comes forward. Staff should order this. Utilities are nearby.
5	Private Utility Locations and Specs (elec, gas, tele).		Staff can flip this fairly quick if a user comes forward. Staff should order this. Utilities are nearby.
6	Geotechnical Soils Evaluation		Do not have on file. However, we do have other documents that should suffice.
7	Phase I ESA	✓*	*Done, 2001, technically only good for one year. Buyer will need to do this. Or, city to be pro-active.
8	Additional ESAs or Environmental Reports	✓*	*Done, 2001. Phase II ESA, Closure Letter, Hazardous Materials Survey were completed. Site has a history.
9	National Wetland Inventory and Flood Plain Maps		Never obtained. Technically not part of MN Formal Shovel Ready application.
10	Site Photos and Site Specs		Do not have on file.
11	Community Profile	✓	Done, 2017.
12	Other Items Cut/ fill, topography, traffic counts, tree inventory, development fees status, subdivision required, public infrastructure status, concept maps, cost-shares, assessments, encumbrances, etc.		Site was previously considered by the Dollar General and Sterling Trophy. In 2017, site lost south bound left-in access from Highway 47. Right in right out northbound access remains today. Site didn't go through formal shovel ready process due to the small size, and likely small sale price. The cost to complete all shovel ready documents can cost \$10K-30K depending on the site. This site does have an encumbrance in favor of the previous owner. They have the right to "approve" the next user, and can stop people from certain excavation requests. This site is heavily documented with the MPCA, because of a previous contamination finding. MPCA staff believes the site should be usable for the next user, so long as they don't have a basement or disturb too much soils. Due to the limited access, nearby better sites, and the encumbrances, staff feels this site may be a challenge to sell.

Site #11

167/47 Node, Water Tower Site

Unplatted

PID [11-32-25-43-0004](#)

Size 14.22 acres (6.75)

Rural Residential



Shovel Ready Status

1	MN Formal Shovel Ready Application		Not completed. Sale price too small to justify the investment.
2	Title Work	✓	Done, 2011.
3	ALTA Survey		Do not have on file. Staff should order this.
4	Public Utility Locations and Specs (water, sewer, storm)		Do not have on file. No storm, water adjacent, no sewer. As-builts available.
5	Private Utility Locations and Specs (elec, gas, tele).		Do not have on file. Utilities adjacent. As-builts available.
6	Geotechnical Soils Evaluation		Do not have on file.
7	Phase I ESA		Do not have on file.
8	Additional ESAs or Environmental Reports		Do not have on file.
9	National Wetland Inventory and Flood Plain Maps		Do not have on file. Staff should order this. Technically not part of MN Formal Shovel Ready application.
10	Site Photos and Site Specs		Do not have on file.
11	Community Profile	✓	Done, 2017.
12	Other Items Cut/ fill, topography, traffic counts, tree inventory, development fees status, subdivision required, public infrastructure status, concept maps, cost-shares, assessments, encumbrances, etc.		This is the water tower site located SW of 167/47 node, and just north of Elmcrest Park. Site has irregular circumstances: (1) major gas line/ easement, (2) water tower, (3) need to realign quicksilver, (4) no sewer available today, (4) desire from golf course for major redevelopment project, (5) includes three odd shaped parcels, (6) much of site is likely not usable, (7) a major development may trigger need for a traffic analysis. May warrant pro-active platting to delineate wetlands, quicksilver, and water tower. Estimated sale price too small to justify investment in formal MN shovel ready app. Quicksilver is a major question mark. Not easy to sell in the foreseeable future, staff has received very little interest. More discussion needed, staff recommends completing various items.

Site #13

Alpine/ Puma, Legacy Plat Payment
Outlot C Alpha Development

PID [20-32-25-31-0003](#)

Size 4.1 acres
R1 Residential

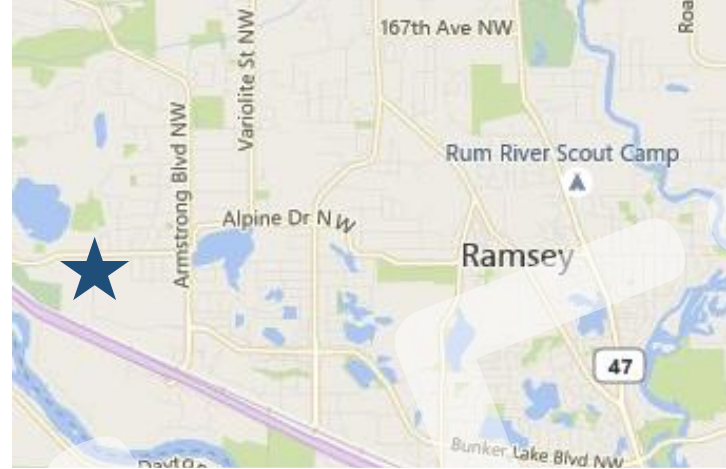

Shovel Ready Status

1	MN Formal Shovel Ready Application		Not completed. Sale price too small to justify the investment.
2	Title Work	✓	Done, 2011.
3	ALTA Survey		Do not have on file. Could use former plat for reference.
4	Public Utility Locations and Specs (water, sewer, storm)		Do not have on file. This item is changing. Utilities are nearby.
5	Private Utility Locations and Specs (elec, gas, tele).		Do not have on file. This item is changing. Utilities are nearby.
6	Geotechnical Soils Evaluation		Do not have on file.
7	Phase I ESA		Do not have on file.
8	Additional ESAs or Environmental Reports		Do not have on file.
9	National Wetland Inventory and Flood Plain Maps		Do not have on file. Technically not part of MN Formal Shovel Ready application.
10	Site Photos and Site Specs		Do not have on file.
11	Community Profile	✓	Done, 2017.
12	Other Items Cut/ fill, topography, traffic counts, tree inventory, development fees status, subdivision required, public infrastructure status, concept maps, cost-shares, assessments, encumbrances, etc.		This site will be split by the future realignment of Puma street. This site was obtained by the city as payment in lieu of park dedication fees for the formerly proposed legacy Christian academy campus. The original intent was not for the city to develop a park here. The original intent was for the city to sell this property, and direct the land proceeds to the city's park fund. One half of this site is under contract for purchase by Capstone Homes today, and is suspected to close in the summer of 2018. The other half is available for purchase. Considering the low land proceeds predicted for the second half of this site, staff doesn't think it's worth investing in the formal shovel ready process. This site is competitively situated and is expected to sell in the next two years.

Site #28

6950 141st, Basalt/ Bunker Business Park

Unplatted

PID [27-32-25-44-0003](#)

Size 0.95
Industrial



Shovel Ready Status

1	MN Formal Shovel Ready Application		Not completed. Sale price was too small to justify the investment.
2	Title Work	✓	Done, 2011.
3	ALTA Survey		Do not have on file. Could use former plat for reference.
4	Public Utility Locations and Specs (water, sewer, storm)		Do not have on file. Utilities are adjacent. As-builts are readily available.
5	Private Utility Locations and Specs (elec, gas, tele).		Do not have on file. Utilities are adjacent.
6	Geotechnical Soils Evaluation		Do not have on file.
7	Phase I ESA		Do not have on file.
8	Additional ESAs or Environmental Reports		Do not have on file.
9	National Wetland Inventory and Flood Plain Maps		Do not have on file. Technically not part of MN Formal Shovel Ready application.
10	Site Photos and Site Specs		Do not have on file.
11	Community Profile	✓	Done, 2017.
12	Other Items Cut/ fill, topography, traffic counts, tree inventory, development fees status, subdivision required, public infrastructure status, concept maps, cost-shares, assessments, encumbrances, etc.		This site is located within the city's existing business park. It has been considered by 24 Restore, All Seasons Garage Door, and two other users recently. The site is a perfect rectangle, and is adjacent to most utilities. This site does have a lot of trees, and may be a candidate for a pro-active tree inventory. This site does benefit from a regional stormwater connection. Although this site is small, it is perfect for a small/ cost-effective project (10K sf project for example). Due to the expected low land proceeds from a sale, staff didn't think this site justified the investment into a formal shovel ready application process. This site is competitively situated and is expected to sell in the next two years.

Site #37 A&B

Former BA Cylinder Site, Former PW Campus
Multiple Parcels and ROW

PID [27-32-25-33-0006](#), [27-32-25-33-0017](#), [27-32-25-33-0009](#)

Size variable, 6 to 9 acres
Industrial



Shovel Ready Status

1	MN Formal Shovel Ready Application	✓*	*All shovel ready info done. Obstacles exist, doesn't warrant formal MN app. WSB Shovel Ready report available.
2	Title Work	✓	Done, 2016.
3	ALTA Survey	✓	Done, 2016.
4	Public Utility Locations and Specs (water, sewer, storm)	✓	Done, 2016. Utilities are adjacent.
5	Private Utility Locations and Specs (elec, gas, tele).		Do not have on file. Utilities are adjacent.
6	Geotechnical Soils Evaluation	✓	Done, 2016.
7	Phase I ESA	✓	Done, 2017. Site has several findings.
8	Additional ESAs or Environmental Reports	✓	Phase II ESA (three rounds). Site has several findings. Enrolling into brownfields program.
9	National Wetland Inventory and Flood Plain Maps		Do not have on file. Staff should complete this. Technically not part of MN Formal Shovel Ready application.
10	Site Photos and Site Specs	✓	Done, 2016.
11	Community Profile	✓	Done, 2017.
12	Other Items Cut/ fill, topography, traffic counts, tree inventory, development fees status, subdivision required, public infrastructure status, concept maps, cost-shares, assessments, encumbrances, etc.		This site is located within the city's existing business park. It includes three parcels and ROW. About one half of the site is the former BA Cylinder site. About one half of the site was land previously earmarked for the city's future public works campus (no longer needed). This site has a large host of items that do not make it attractive/ practical for development in the near future: (1) Ramsey Blvd. RR Underpass will have a large effect on this parcel, including taking of land and easements, however the scope is unknown today, (2) the site has several documented contamination items that are currently being resolved by staff and the MPCA, but will take time, (3) the city's PW campus is still using a small portion of this site, (4) the sites proximity to rail make it competitive for its zoning.

Site #40

Former Book Store Location

6710 Highway 10, Lot 4, Block 1, Riverside West

PID [34-32-25-13-0005](#)

Size 1.23 Acres
Retail/ Commercial

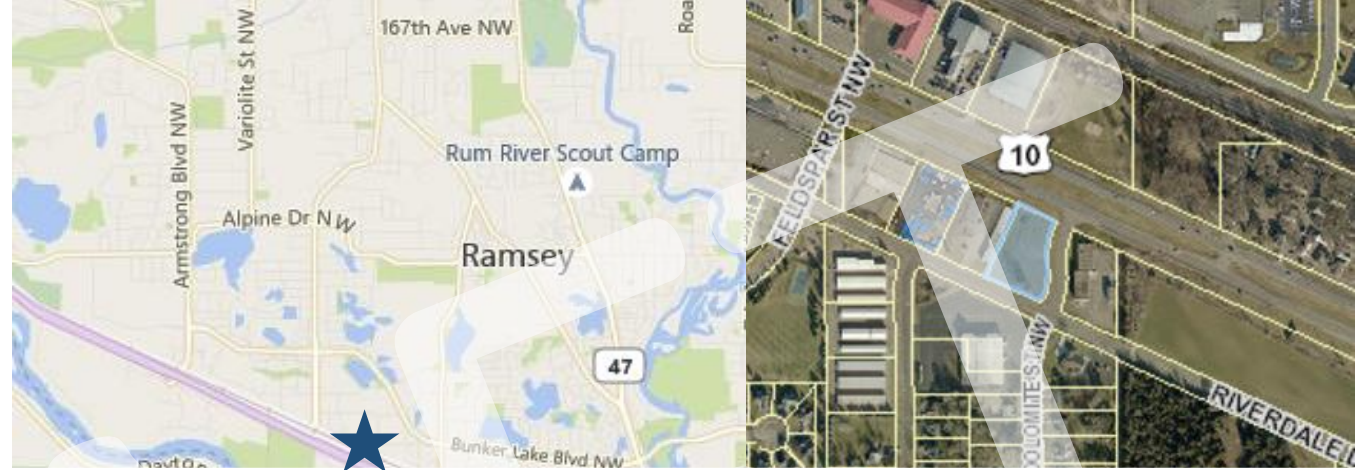

Shovel Ready Status

1	MN Formal Shovel Ready Application		Not completed. Sale price too small to justify the investment.
2	Title Work	✓	Outdated, 2012. New title work should be ordered and examined for potential issues.
3	ALTA Survey		Do not have on file. Could use former plat for reference.
4	Public Utility Locations and Specs (water, sewer, storm)		Do not have on file. Utilities are nearby (sewer and water). Storm not available. As-builts available.
5	Private Utility Locations and Specs (elec, gas, tele).		Do not have on file. Utilities are nearby.
6	Geotechnical Soils Evaluation		Do not have on file.
7	Phase I ESA		Do not have on file.
8	Additional ESAs or Environmental Reports		Do not have on file.
9	National Wetland Inventory and Flood Plain Maps		Do not have on file. Technically not part of MN Formal Shovel Ready application.
10	Site Photos and Site Specs		Do not have on file.
11	Community Profile	✓	Done, 2017.
12	Other Items Cut/ fill, topography, traffic counts, tree inventory, development fees status, subdivision required, public infrastructure status, concept maps, cost-shares, assessments, encumbrances, etc.		This is the former adult bookstore site located on Highway 10. The city purchased this site to remove blight. This site has been considered by All Seasons Garage Door, Sterling Trophy, and several used car dealerships. This site has excellent visibility. Access today is good to Hwy 10 today, but will be cut off in the future, and will rely to the backage road. This site doesn't have access to a regional stormwater outlet—therefore will need to account for all storm water on site. At the time of purchase, it was informally indicated land proceeds from this site would be deposited within the EDA fund. This site is competitively situated and is expected to sell in the next two years.

Site #55

Former Bury Carlson Site

Lot 1, Block 1, Bury Carlson Addition

PID [27-32-25-34-0009](#)

Size variable, about 9.3 acres
Industrial



Shovel Ready Status

1	MN Formal Shovel Ready Application	No, but*	*Staff would like to complete a formal MN Shovel Ready App. Much information already completed.
2	Title Work	✓	Done, 2017.
3	ALTA Survey	✓	Done, 2017.
4	Public Utility Locations and Specs (water, sewer, storm)	✓	Done, 2017. Utilities are adjacent.
5	Private Utility Locations and Specs (elec, gas, tele).	✓	Done, 2017. Utilities are adjacent.
6	Geotechnical Soils Evaluation	✓	Done, 2017.
7	Phase I ESA		Do not have on file. Staff should complete this.
8	Additional ESAs or Environmental Reports		Do not have on file. Staff should complete this.
9	National Wetland Inventory and Flood Plain Maps		Do not have on file. Staff should complete this. Technically not part of MN Formal Shovel Ready application.
10	Site Photos and Site Specs		Do not have on file. Staff should complete this.
11	Community Profile	✓	Done, 2017.
12	Other Items Cut/ fill, topography, traffic counts, tree inventory, development fees status, subdivision required, public infrastructure status, concept maps, cost-shares, assessments, encumbrances, etc.		This site is located within the city's existing business park. This site is about 20 acres, and was purchased by the city from Bury Carlson with the intent to use if for a future public works campus. In 2015, the city completed a space needs analysis for the future PW campus and found that the northern 9.3 acres of this site available for sale/ development. Since 2016, the site has been locked up in two PAs. Staff thinks this site should be enrolled in the formal MN shovel ready program, that is should be proactively subdivided, that storm water needs to be addressed, and that access to the graveyard needs to be addressed. This site is very attractive for industrial users, and staff expects it to sell within the next few years.

Site #42

The COR, retail pad sites near Armstrong
Lots 1, 2, and 3, COR TWO

PID [28-32-25-23-0012](#), [28-32-25-23-0013](#), [28-32-25-23-0011](#)

Size variable, about 4 acres (3 parcels)
COR Retail



Shovel Ready Status

1	MN Formal Shovel Ready Application	✓*	*All shovel ready info done. Retail use doesn't warrant formal MN app. WSB Shovel Ready report available.
2	Title Work	✓	2013. New title work needed due to former PA and restrictive covenants.
3	ALTA Survey	✓	Done, 2016.
4	Public Utility Locations and Specs (water, sewer, storm)	✓	Done, 2016. Utilities are within site—pad ready.
5	Private Utility Locations and Specs (elec, gas, tele).	✓	Done, 2016. Utilities are adjacent.
6	Geotechnical Soils Evaluation	No*	Do not have on file. Larger adjacent COR retail parcel completed this item.
7	Phase I ESA	No*	Do not have on file. Larger adjacent COR retail parcel completed this item.
8	Additional ESAs or Environmental Reports	No*	Do not have on file. Larger adjacent COR retail parcel completed this item.
9	National Wetland Inventory and Flood Plain Maps		Do not have on file. Technically not part of MN Formal Shovel Ready application.
10	Site Photos and Site Specs		Do not have on file.
11	Community Profile	✓	Done, 2017.
12	Other Items Cut/ fill, topography, traffic counts, tree inventory, development fees status, subdivision required, public infrastructure status, concept maps, cost-shares, assessments, encumbrances, etc.		Located at Sunwood and Armstrong on the west end of The COR. These are the three “pad ready” retail sites formerly considered by SA, McDonald's, and a Liquor Store. To save dollars, staff did not formally enroll this parcel in the MN Shovel Ready Program. The larger, adjacent, mother parcel, which is also zoned COR retail, was enrolled in the MN Shovel Ready program. Although being pad ready is helpful in many ways, having pre-determined, pre-platted, pre-utility-stubbed sites, can create some challenges for end users (as they need to fit the fixed site specs). At this point, staff doesn't think that is an obstacle. There is a stormwater basin that needs to be addressed. Easements for, and maintenance of, internal infrastructure will need to be resolved in the future.

Site #45

The COR, west of Armstrong
8020 147th and 8019 146th

PID [29-32-25-14-0009](#), [29-32-25-14-0010](#)

Size variable, about 2 acres
COR Retail, Redevelopment Area

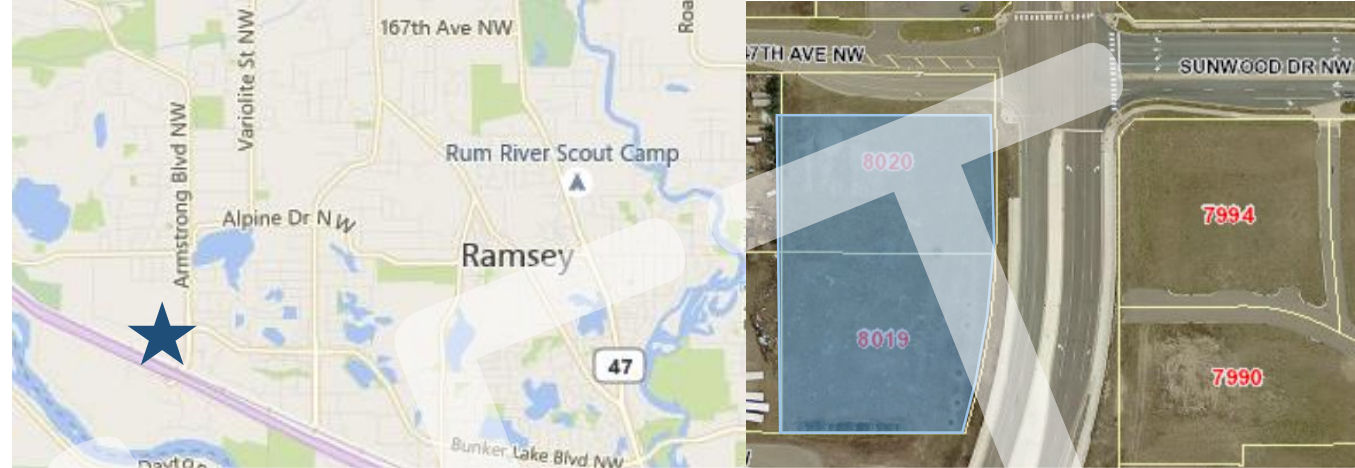

Shovel Ready Status

1	MN Formal Shovel Ready Application	✓*	*All shovel ready info done. Retail use doesn't warrant formal MN app. WSB Shovel Ready report available.
2	Title Work	✓	Done, 2016.
3	ALTA Survey	✓	Done, 2016.
4	Public Utility Locations and Specs (water, sewer, storm)	✓	Done, 2016. Utilities are adjacent.
5	Private Utility Locations and Specs (elec, gas, tele).	✓	Done, 2016. Utilities are adjacent.
6	Geotechnical Soils Evaluation	✓	Done, 2016.
7	Phase I ESA	✓	Done, 2016. Some items were identified.
8	Additional ESAs or Environmental Reports	✓	Phase II ESA done, 2016. Site appears to be usable following a RAP.
9	National Wetland Inventory and Flood Plain Maps		Do not have on file. Technically not part of MN Formal Shovel Ready application.
10	Site Photos and Site Specs	✓	Done, 2016.
11	Community Profile	✓	Done, 2017.
12	Other Items Cut/fill, topography, traffic counts, tree inventory, development fees status, subdivision required, public infrastructure status, concept maps, cost-shares, assessments, encumbrances, etc.		May warrant pro-active platting process for the following reasons: (1) account for 147 th ROW, (2) combine both parcels, (3) address remnant parcels/ cul-de-sac area to the south. Based on the Phase II ESA results, appears the site is usable. However, some precautions will need to be taken during construction of a new development—which will depend on what's being proposed—and the developer will be taking on a minor risk. This may or may not have an effect on the salability of this site. Because other comparable, nearby sites exist today, without any potential contamination concerns, this site may not be a buyer first choice. Staff has received very little interest in this site—if at all. This site may be well suited to combine with adjacent sites for a larger redevelopment project.

Site #46

The COR, west of Armstrong Redevelopment Area

Outlot A, COR TWO

PID [28-32-25-22-0058](#)

Size variable, about 30.76, could be 2-3 parcels
COR Retail, potentially flexible uses

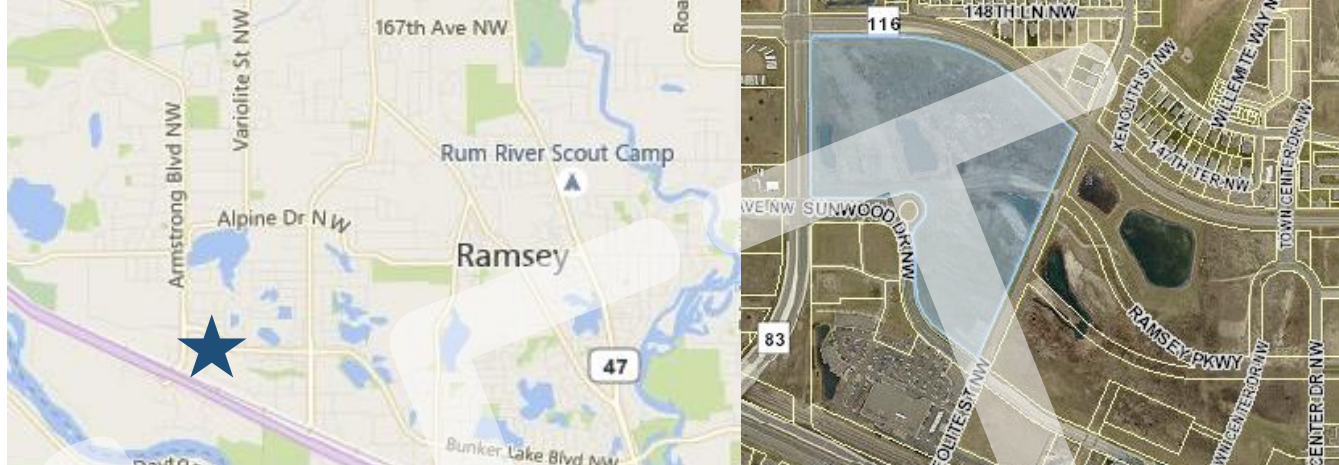

Shovel Ready Status

1	MN Formal Shovel Ready Application	✓*	*All shovel ready info done. Retail use doesn't warrant formal MN app. WSB Shovel Ready report available.
2	Title Work	✓	Done, 2016.
3	ALTA Survey	✓	Done, 2016.
4	Public Utility Locations and Specs (water, sewer, storm)	✓	Done, 2016. Utilities are adjacent.
5	Private Utility Locations and Specs (elec, gas, tele).	✓	Done, 2016. Utilities are adjacent.
6	Geotechnical Soils Evaluation	✓	Done, 2016.
7	Phase I ESA	✓	Done, 2016.
8	Additional ESAs or Environmental Reports	✓	NA, Phase I was clean.
9	National Wetland Inventory and Flood Plain Maps		Do not have on file. Staff should complete this. Technically not part of MN Formal Shovel Ready application.
10	Site Photos and Site Specs	✓	Done, 2016.
11	Community Profile	✓	Done, 2017.
12	Other Items Cut/ fill, topography, traffic counts, tree inventory, development fees status, subdivision required, public infrastructure status, concept maps, cost-shares, assessments, encumbrances, etc.		Located in NW corner of The COR (SE corner of Bunker/ Armstrong). Today, site is roughly 30.76 acres in size. However, site will be split at least one time (by Ramsey Parkway). The northern lot will be about 22.5 acres and the southern site will be about 6 acres. At least two acres will be lost to ROW for Ramsey Parkway (maybe more for N/S road). Staff would like to confirm and/or delineate wetlands. Other important notes: (1) site will shoulder partial responsibility for certain infrastructure, (2) site will require relocation stormwater pond, (3) site will require significant fill, (4) site is a good candidate for a pro-active tree inventory, (5) site is a good candidate for a pro-active platting. Strong chance site will NOT sell for asking price. Zoning in this area appears to be flexible.

Site #47

The COR, West of Transit Station
 Outlot A & B, COR Stone Brook
 PID [28-32-25-23-0018](#), [28-32-25-31-0023](#)
 Size: A 0.52, B 3.13 Acres
 COR Retail

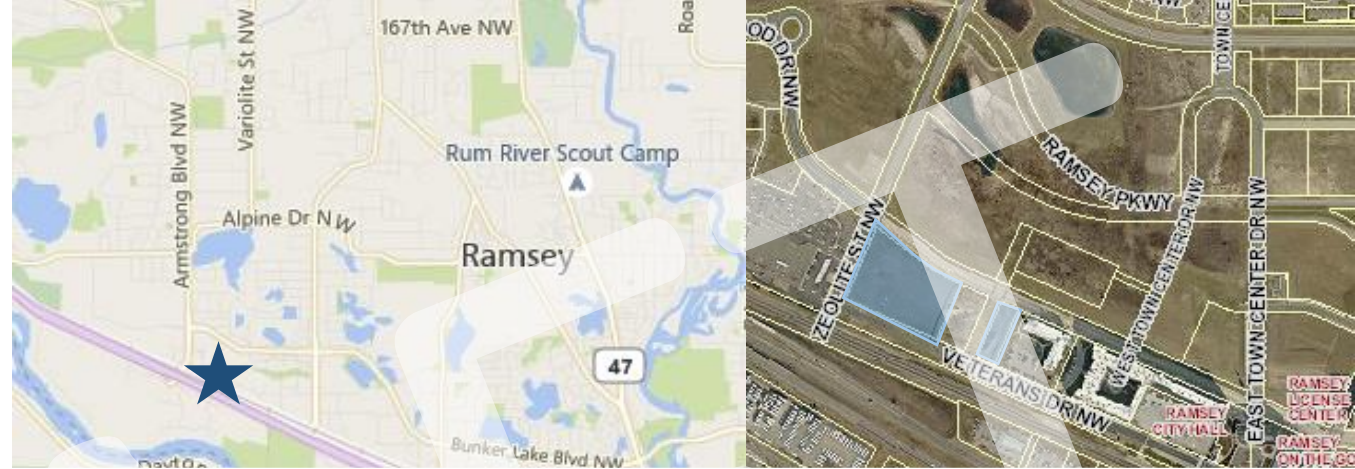

Shovel Ready Status

1	MN Formal Shovel Ready Application	✓*	*Not completed. Retail use not good candidate for the formal MN Shovel Ready program. Small sites.
2	Title Work	✓	Done, 2017.
3	ALTA Survey	✓	Done, 2017.
4	Public Utility Locations and Specs (water, sewer, storm)	✓	Done, 2017. Utilities adjacent.
5	Private Utility Locations and Specs (elec, gas, tele).	✓	Done, 2017. Utilities adjacent.
6	Geotechnical Soils Evaluation	No*	Do not have on file. Larger adjacent COR retail parcel completed this item.
7	Phase I ESA	No*	Do not have on file. Larger adjacent COR retail parcel completed this item.
8	Additional ESAs or Environmental Reports	No*	Do not have on file. Larger adjacent COR retail parcel completed this item.
9	National Wetland Inventory and Flood Plain Maps		Do not have on file. Technically not part of MN Formal Shovel Ready application.
10	Site Photos and Site Specs		Do not have on file.
11	Community Profile	✓	Done, 2017.
12	Other Items Cut/ fill, topography, traffic counts, tree inventory, development fees status, subdivision required, public infrastructure status, concept maps, cost-shares, assessments, encumbrances, etc.		This site was recently split by the Stone Brook Children’s Academy project, and Yolite Street. To the west is a 3.13 acre parcel, and to the east a 0.52 acre parcel. The parcel to the east is in very good condition for development, although it is small—not much to note. The parcel to the west is also prime for development. However, there are a couple items to note: (1) fill will be needed on this site, (2) the public well/ easement will need to be addressed. This site does have very good visibility from Highway 10 (one of the only sites in the The COR). The City has been approached by several multi-family developers interested in this site—the city has affirmed they don’t want a pure residential development on this site—but, may be open to a mixed use development.

Site #48

The COR, NW of Transit Station

8 individual parcels plus various ROW

Size variable, about 23, could be 5-8 parcels

COR Retail and COR-1 Mixed



Shovel Ready Status

1	MN Formal Shovel Ready Application	✓*	*All shovel ready info done. Retail use doesn't warrant formal MN app. WSB Shovel Ready report available.
2	Title Work	✓	Done, 2016.
3	ALTA Survey	✓	Done, 2016.
4	Public Utility Locations and Specs (water, sewer, storm)	✓	Done, 2016. Utilities are adjacent.
5	Private Utility Locations and Specs (elec, gas, tele).	✓	Done, 2016. Utilities are adjacent.
6	Geotechnical Soils Evaluation	✓	Done, 2016.
7	Phase I ESA	✓	Done, 2016.
8	Additional ESAs or Environmental Reports	✓	NA, Phase I was clean.
9	National Wetland Inventory and Flood Plain Maps		Do not have on file. Staff should complete this. Technically not part of MN Formal Shovel Ready application.
10	Site Photos and Site Specs	✓	Done, 2016.
11	Community Profile	✓	Done, 2017.

12	Other Items Cut/ fill, topography, traffic counts, tree inventory, development fees status, subdivision required, public infrastructure status, concept maps, cost-shares, assessments, encumbrances, etc.		Site located in the heart of The COR. Site has lots of variables worth noting: (1) it has at least eight parcels toady and is a strong candidate for a pro-active platting process, (2) has lots of trees and is a strong candidate for a pro-active tree inventory, (3) will need significant fill, (4) will need significant public infrastructure improvements, (5) is wedged between two zoning districts and may need some clarifying, (5) may be a candidate for a parking ramp, (6) may need to clarify/ confirm the storm water situation, (7) is earmarked for the location of a community center, and (8) earmarked for the location of a park. This is site is desirable and attractive. Inland has a PA in place for a portion of this site (about 4.2 acres). Lot's of work is on the horizon for this site.
----	---	--	---

Site #50

The COR, East Side Office/ Medical Park
Outlot A & B, COR Stone Brook

PID [28-32-25-41-0020](#)

Size: 13.09 Acres (likely 9 usable)
COR Office Park



Shovel Ready Status

1	MN Formal Shovel Ready Application	✓	Done, 2017.
2	Title Work	✓	Done, 2016.
3	ALTA Survey	✓	Done, 2016.
4	Public Utility Locations and Specs (water, sewer, storm)	✓	Done, 2016. Utilities are adjacent.
5	Private Utility Locations and Specs (elec, gas, tele).	✓	Done, 2016. Utilities are adjacent.
6	Geotechnical Soils Evaluation	✓	Done, 2016.
7	Phase I ESA	✓	Done, 2016.
8	Additional ESAs or Environmental Reports	✓	NA, Phase I was clean.
9	National Wetland Inventory and Flood Plain Maps		Do not have on file. Staff should complete this. Technically not part of MN Formal Shovel Ready application.
10	Site Photos and Site Specs	✓	Done, 2016.
11	Community Profile	✓	Done, 2017.
12	Other Items Cut/ fill, topography, traffic counts, tree inventory, development fees status, subdivision required, public infrastructure status, concept maps, cost-shares, assessments, encumbrances, etc.		This site is located in the SE corner of The COR, near Casey's. Generally, this site is in a good position. Items that will come up in the future: (1) payment/ construction of public infrastructure Peridot and Veterans and (2) effect of COR regional storm water infiltration basin.

Site #51

The COR, NE Corner, Bunker/ Ramsey Blvd

Unplatted

PID [28-32-25-14-0094](#)

Size 4.29 acres

COR Medium Density Residential



Shovel Ready Status

1	MN Formal Shovel Ready Application		Not completed. Sale price too small to justify the investment.
2	Title Work	✓	Done, 2011.
3	ALTA Survey		Do not have on file. Staff should order this.
4	Public Utility Locations and Specs (water, sewer, storm)		Do not have on file. Utilities adjacent. As-builts available.
5	Private Utility Locations and Specs (elec, gas, tele).		Do not have on file. Utilities adjacent. As-builts available.
6	Geotechnical Soils Evaluation		Do not have on file.
7	Phase I ESA		Do not have on file.
8	Additional ESAs or Environmental Reports		Do not have on file.
9	National Wetland Inventory and Flood Plain Maps		Do not have on file. Staff should order this. Technically not part of MN Formal Shovel Ready application.
10	Site Photos and Site Specs		Do not have on file.
11	Community Profile	✓	Done, 2017.
12	Other Items Cut/ fill, topography, traffic counts, tree inventory, development fees status, subdivision required, public infrastructure status, concept maps, cost-shares, assessments, encumbrances, etc.		This parcel is located in the NE corner of The COR and is guided for medium density residential (SW corner of Bunker/ Ramsey Blvd). This parcel may need some fill. Quality of product design will be important. No major comments regarding this site. Access will come internally (not from Bunker/ Ramsey). The city is actively negotiating a PA on this site right now.

Site #BLIP, PSD

Multiple Parcels

Bunker Lake Industrial Park

PSD Owned Portion

Size about 45 acres

E3 Employment



Shovel Ready Status

1	MN Formal Shovel Ready Application	✓	Done, 2017.
2	Title Work	✓	Done, 2016.
3	ALTA Survey	✓	Done, 2016.
4	Public Utility Locations and Specs (water, sewer, storm)	✓	Done, 2016. Utilities are adjacent.
5	Private Utility Locations and Specs (elec, gas, tele).	✓	Done, 2016. Utilities are adjacent.
6	Geotechnical Soils Evaluation	✓	Done, 2016.
7	Phase I ESA	✓	Done, 2016.
8	Additional ESAs or Environmental Reports	✓	NA, Phase I was clean.
9	National Wetland Inventory and Flood Plain Maps		Do not have on file. Staff should complete this. Technically not part of MN Formal Shovel Ready application.
10	Site Photos and Site Specs	✓	Done, 2016.
11	Community Profile	✓	Done, 2017.
12	Other Items Cut/ fill, topography, traffic counts, tree inventory, development fees status, subdivision required, public infrastructure status, concept maps, cost-shares, assessments, encumbrances, etc.		This is the southern 45-acre portion of the new Ramsey business park. This portion of the business park is ready for development. No major concerns. This is not owned by the city—it's owned by PSD LLC.

Site #BLIP, Hageman

Multiple Parcels
 Bunker Lake Industrial Park
 PSD Owned Portion
 Size about 45 acres
 E3 Employment

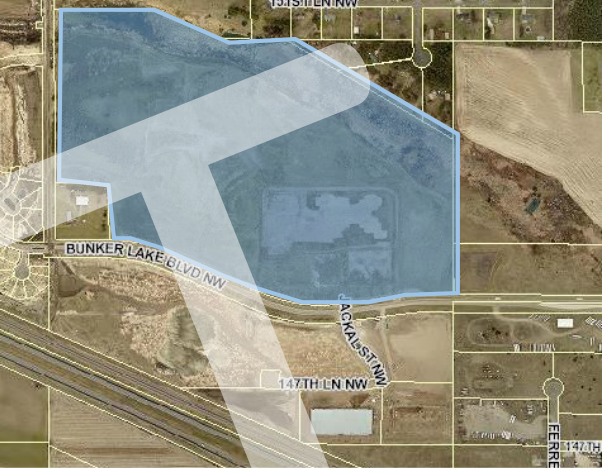

Shovel Ready Status

1	MN Formal Shovel Ready Application	No, but*	*Staff would like to complete a formal MN Shovel Ready App. Much information already completed.
2	Title Work	✓	Done, 2011.
3	ALTA Survey	✓	Done, 2011.
4	Public Utility Locations and Specs (water, sewer, storm)	✓	Done, 2017. Utilities are adjacent.
5	Private Utility Locations and Specs (elec, gas, tele).	✓	Done, 2017. Utilities are adjacent.
6	Geotechnical Soils Evaluation	✓	Done, 2011.
7	Phase I ESA	✓	Done, 2011.
8	Additional ESAs or Environmental Reports		Shouldn't be needed.
9	National Wetland Inventory and Flood Plain Maps		Do not have on file. Staff should complete this. Technically not part of MN Formal Shovel Ready application.
10	Site Photos and Site Specs		Do not have on file. Staff should complete this.
11	Community Profile	✓	Done, 2017.
12	Other Items Cut/ fill, topography, traffic counts, tree inventory, development fees status, subdivision required, public infrastructure status, concept maps, cost-shares, assessments, encumbrances, etc.		This is the northern 62-acre portion of the new Ramsey business park. This portion of the business park is greenfield and is close to ready for development (not as ready as PSD). This is not owned by the city—it's owned by Hageman Holdings. Staff believes all previous work completed by Hageman Holdings needs to be verified/ updates may be needed. Some items staff thinks are worth noting is: (1) potential need for fill in some areas, (2) need to address storm water plan that was previously put in place, (3) Hageman Holdings doesn't want to sell small pieces of property (i.e. less than 10 acres), and (4) internal public infrastructure may or may not be needed—depending on the size of future users. This property fits well within the MN Shovel Ready program.

Site #COR South, PSD

Multiple Parcels

Commercial Area South of COR on Riverdale

Parcels: [28-32-25-34-0002](#), [28-32-25-43-0007](#), [28-32-25-34-0006](#)

Size about 42 acres (35)

B2 Business

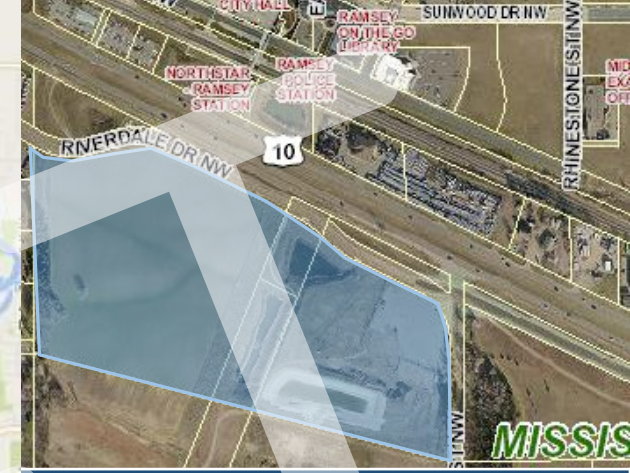

Shovel Ready Status

1	MN Formal Shovel Ready Application	No, but*	*Staff would like to complete a formal MN Shovel Ready App. Much information already completed.
2	Title Work	✓	Likely completed at some point, need to track down.
3	ALTA Survey	✓	Likely completed at some point, need to track down.
4	Public Utility Locations and Specs (water, sewer, storm)	✓	Utilities are adjacent, need to document.
5	Private Utility Locations and Specs (elec, gas, tele).	✓	Utilities are adjacent, need to document.
6	Geotechnical Soils Evaluation	✓	Likely completed at some point, need to track down.
7	Phase I ESA	✓	Likely completed at some point, need to track down.
8	Additional ESAs or Environmental Reports		Shouldn't be needed.
9	National Wetland Inventory and Flood Plain Maps		Do not have on file. Staff should complete this. Technically not part of MN Formal Shovel Ready application.
10	Site Photos and Site Specs		Do not have on file.
11	Community Profile	✓	Done, 2017.
12	Other Items Cut/ fill, topography, traffic counts, tree inventory, development fees status, subdivision required, public infrastructure status, concept maps, cost-shares, assessments, encumbrances, etc.		This is the roughly 40-acre piece of land located directly south of The COR, which could potentially be connected by skyway to The COR/ the Northstar. This site is zoned B2 which makes it available for retail and office type users. Do to the size and location of this site, staff would support working with PSD LLC to get this site shovel ready.

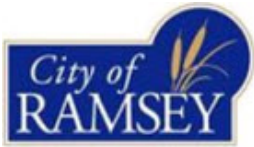

Our Mission: To work together to responsibly grow our community, and to provide quality, cost-effective, and efficient government services.

CC Work Session

3. 1.

Meeting Date: 02/12/2018

Submitted For: Kurt Ulrich, Administrative Services

By: Jo Thieling, Administrative Services

Information

Title:

Review and Prioritize Future Topics/Calendar

Purpose/Background:

Attached is the current list of future topics for work session discussion. Items are drawn from Council requests at meetings, or are related to topics that have been identified in the City's strategic plan. There are two attachments. The first attachment is a redlined version of the future topics document that staff has reviewed and determined complete or no longer necessary. The topics deleted are actually shown in red strike-through. The second attachment is the same list of future topics with the red-lined topics removed.

Staff is asking for Council's input with regard to dismissing the red-lined topics and to prioritize the remaining topics.

Recommendation:

N/A

Action:

For Council review.

Attachments

[Future Topics Redlined](#)

[Future Topics Proposed Final](#)

Form Review

Inbox

Kurt Ulrich

Form Started By: Jo Thieling

Final Approval Date: 02/08/2018

Reviewed By

Kurt Ulrich

Date

02/08/2018 03:15 PM

Started On: 02/06/2018 09:16 PM

City Council Future Topics – Work Session
(Draft)

Date	Topics for Discussion – Council Action
Future	Discuss Ordinance Governing Unmanned Aerial Vehicle Use (Katers) Unnecessary discussion at this time
Future	Review and Consider Adoption of Ramsey’s Portion of Previous Highway 47 Study (Westby)
Future	Cost Share for Corridor Study of Nowthen Blvd/CR5 (Westby)
Future	Intersection Control Evaluation for Spot Improvements on Armstrong (Westby)
Future	Discussion re Tap Rooms/Brew Pubs (Thieling/Katers) Unnecessary discussion at this time
Future	Assessment Policy Review (Westby) Combined with Discussion of Road Financing Options
Future	Review State of Minnesota and Anoka County Recycling Goals for 2030 and Discuss Options for Achieving Goals (Anderson)
Future	Discuss Trunk Sewer and Water Through Riverstone (Gladhill) Unnecessary discussion at this time
February	Attend Meeting via Skype Discussion (Gladhill) Duplicate
February	Review Road Financing Options/Assessment Policy Review (Ulrich & Westby)
February 27	6745 Highway 10 Lease Renewal Request (Brama)
Future	Discuss Changing the Names of the Future Streets in The COR (request by Councilmember Riley)
Future	Ferry Street Traffic Control (request by Councilmember Riley)
Date	Topics for Discussion – Regulatory
Future	Commercial Signage Standards and Community Sign Plan (Gladhill) Unnecessary discussion at this time
Future	Property Maintenance Code (Maintenance of Buildings and Structures) (Gladhill) Unnecessary discussion at this time
Future	Discuss Amendment to Purchasing Policy (Katers) Completed
Date	Topics for Discussion – Policy
Future	Trail Maintenance Policy (Westby)
Future	Stormwater Pond Maintenance Policy (Westby)
Future	Citizen Volunteer and Recognition Program (U of M RCP Program) Unnecessary discussion at this time
Future	Newsletter Policy to Address Advertising and Content Control (Brama)
Future	Attendance and Participation at City Meetings (Council and Commissioners) via Electronic Medium) (Ulrich)
February	Discussion re Board and Commission Interview Process (Lasher) Completed
Date	Topics for Discussion – Planning and Budget
Future	Summary of Compensation/Development Plan for Employees (Lasher)
Future	Review Comprehensive Plan for Long Term Water Supply (Westby) Duplicate
Date	Topics for Discussion – Information
Future	Receive Update on Rental License Program Implementation (Gladhill)

Future	Discuss Next Steps for Comprehensive Plan Update (<i>Gladhill</i>)—Next step completed
February	Met Council Update on Surface Water Supply Planning Funding Assistance (<i>Westby</i>)
Future	2017 Business Retention and Expansion Program Report (<i>Brama</i>)
February 27	Photo Contest (<i>Riverblood</i>)

City Council Future Topics – Work Session
(Draft)

Date	Topics for Discussion – Council Action
Future	Review and Consider Adoption of Ramsey’s Portion of Previous Highway 47 Study (<i>Westby</i>)
Future	Cost Share for Corridor Study of Nowthen Blvd/CR5 (<i>Westby</i>)
Future	Intersection Control Evaluation for Spot Improvements on Armstrong (<i>Westby</i>)
Future	Review State of Minnesota and Anoka County Recycling Goals for 2030 and Discuss Options for Achieving Goals (<i>Anderson</i>)
February	Review Road Financing Options/Assessment Policy Review (<i>Ulrich & Westby</i>)
February 27	6745 Highway 10 Lease Renewal Request (<i>Brama</i>)
Future	Discuss Changing the Names of the Future Streets in The COR (<i>request by Councilmember Riley</i>)
Future	Ferry Street Traffic Control (<i>request by Councilmember Riley</i>)
Date	Topics for Discussion – Regulatory
Date	Topics for Discussion – Policy
Future	Trail Maintenance Policy (<i>Westby</i>)
Future	Stormwater Pond Maintenance Policy (<i>Westby</i>)
Future	Newsletter Policy to Address Advertising and Content Control (<i>Brama</i>)
Future	Attendance and Participation at City Meetings (Council and Commissioners) via Electronic Medium) (<i>Ulrich</i>)
Date	Topics for Discussion – Planning and Budget
Future	Summary of Compensation/Development Plan for Employees (<i>Lasher</i>)
Date	Topics for Discussion – Information
Future	Receive Update on Rental License Program Implementation (<i>Gladhill</i>)
February	Met Council Update on Surface Water Supply Planning Funding Assistance (<i>Westby</i>)
Future	2017 Business Retention and Expansion Program Report (<i>Brama</i>)
February 27	Photo Contest (<i>Riverblood</i>)