

# PRELIMINARY PLAT OF: RUM RIVER PRAIRIE

**OWNER/DEVELOPER**

Brookview Estates, LLC  
6210 Green Valley Road  
Ramsey, MN 55303

**PROPERTY DESCRIPTION**

S 1/2 of the NE 1/4 of Section 7, Township 32, Range 25

**NOTE**

Proposed septic areas shown hereon are approximate and for informational purposes only. It is the responsibility of the landowner to determine a final location for the septic area.

**NET DENSITY**

25 Single-Family dwellings  
1 Dwelling per 2.67 Acres (Including Block 4 Lot 1, which has a variance to allow smaller area)

**ZONING**

Rum River Prairie - R-1: Rural Developing (outside MUSA)

East, North, and West - R-1: Rural Developing (outside MUSA)

South - PUD: Planned Unit Development

**SETBACKS**

Front: 40'  
Side: 10'  
Rear: 40'

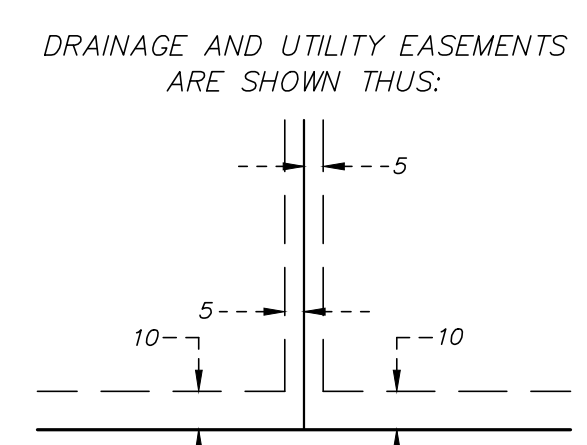

BEING 5 FEET IN WIDTH AND ADJOINING SIDE LOT LINES, ALSO BEING 10 FEET IN WIDTH AND ADJOINING RIGHT-OF-WAY AND REAR LOT LINES, UNLESS OTHERWISE SHOWN ON THIS PLAT.

**LOT AREA TABULATION**

| Block/Lot      | Area (s.f.)    | Area (Acres) |
|----------------|----------------|--------------|
| <b>BLOCK 1</b> |                |              |
| LOT 1          | 139,816 s.f.   | 3.21 Acres   |
| LOT 2          | 116,856 s.f.   | 2.68 Acres   |
| LOT 3          | 108,955 s.f.   | 2.50 Acres   |
| LOT 4          | 111,933 s.f.   | 2.57 Acres   |
| LOT 5          | 108,937 s.f.   | 2.50 Acres   |
| LOT 6          | 109,299 s.f.   | 2.51 Acres   |
| LOT 7          | 175,192 s.f.   | 4.02 Acres   |
| LOT 8          | 158,816 s.f.   | 3.65 Acres   |
| LOT 9          | 108,959 s.f.   | 2.50 Acres   |
| LOT 10         | 108,900 s.f.   | 2.50 Acres   |
| LOT 11         | 109,830 s.f.   | 2.52 Acres   |
| LOT 12         | 108,901 s.f.   | 2.50 Acres   |
| <b>BLOCK 2</b> |                |              |
| LOT 1          | 110,919 s.f.   | 2.55 Acres   |
| LOT 2          | 111,266 s.f.   | 2.55 Acres   |
| LOT 3          | 108,917 s.f.   | 2.50 Acres   |
| LOT 4          | 110,202 s.f.   | 2.53 Acres   |
| LOT 5          | 120,579 s.f.   | 2.77 Acres   |
| LOT 6          | 116,740 s.f.   | 2.68 Acres   |
| LOT 7          | 109,148 s.f.   | 2.51 Acres   |
| LOT 8          | 108,972 s.f.   | 2.50 Acres   |
| <b>BLOCK 3</b> |                |              |
| LOT 1          | 108,935 s.f.   | 2.50 Acres   |
| LOT 2          | 109,019 s.f.   | 2.51 Acres   |
| LOT 3          | 161,200 s.f.   | 3.70 Acres   |
| LOT 4          | 108,974 s.f.   | 2.50 Acres   |
| <b>BLOCK 4</b> |                |              |
| LOT 1          | 59,760 s.f.    | 1.37 Acres   |
| <b>R.O.W.</b>  | 570,582 s.f.   | 13.10 Acres  |
| <b>TOTAL</b>   | 3,481,607 s.f. | 79.93 Acres  |

**LEGEND**

- DENOTES BUILDING SETBACK LINE
- DENOTES DRAINAGE AND UTILITY EASEMENT
- x 250 SEPTIC BORING LOCATION AND NUMBER

I HEREBY CERTIFY THAT THIS SURVEY WAS PREPARED BY ME OR UNDER MY DIRECT SUPERVISION, AND THAT I AM A DULY REGISTERED LAND SURVEYOR UNDER THE LAWS OF THE STATE OF MINNESOTA.

*Kyle J. Roddy*  
KYLE J. RODDY, MN LIC. NO 42627 DATED: 12/26/17

COPYRIGHT 2016 BY LHB, INC. ALL RIGHTS RESERVED.



200 3rd Ave NE, Suite 100 | Cambridge, MN 55005 | 763.689.4042