

**CONTRACT DOCUMENTS AND
TECHNICAL SPECIFICATIONS FOR
CITY OF RAMSEY, MINNESOTA**

IP 18-08 TROTT BROOK BOARDWALK



Prepared By:

City of Ramsey
7550 Sunwood Drive N.W.
Ramsey, Minnesota 55303
(763) 433-9820

ADVERTISEMENT FOR BIDS

The City of Ramsey will receive sealed bids until February 5th, 2018, at 10:30 a.m. for furnishing all labor, material, machinery and tools necessary for City Improvement Project 18-08 Trott Brook Boardwalk, at which time bids will be publicly opened at the Ramsey Municipal Center, 7550 Sunwood Drive NW, Ramsey, MN, 55303.

The boardwalk shall be comprised of all ACQ or MCA treated wood, and include 8' x 8' sections of 2 x 8's with galvanized joist hangers, through-bolted together, and decked with 2 x 10's secured by 3 1/2" GRK Structural Screws. Square, 4 x 4 posts will support and level the approximate 1,500' foot structure with galvanized brackets and pans, placed upon the wetland's surface. A 2 x 4 'curb' structure on both edges will be elevated by regularly spaced blocks functioning as a low 'truss', tying each boardwalk section together as a solid unit.

It is anticipated that a Construction Contract will be awarded on February 12th, 2018, and that work may begin on or about February 26th, 2018.

The contract documents may be examined at the Ramsey Municipal Center, 7550 Sunwood Drive NW, Ramsey, MN, 55303. Copies of the contract documents may be obtained at the above address. The contract documents shall also be available on QuestCDN. These documents may be downloaded by selecting this project and by entering eBidDoc Number 5497165 on the Search Projects page. For assistance and free membership registration, contact QuestCDN at (952) 233-1632 or info@questcdn.com.

All bids shall be submitted in sealed envelopes plainly marked "IP 18-08 Trott Brook Boardwalk". If mailed, bids should be placed in a separate envelope and mailed to the City address noted above to the attention of Parks Superintendent, Mark Riverblood.

Each bidder shall submit, with the proposal, a bidder's bond made payable to the City of Ramsey in the amount of 5% of the total bid. No bidder may withdraw their bid for at least 45 days after the scheduled closing time for the receipt of bids. The City of Ramsey reserves the right to reject any or all bids, and to waive informalities.

By order of the City of Ramsey, Minnesota: January 9th, 2019

Published:

Anoka County Union Herald January 12th, 19th and 26th, 2018

Finance and Commerce January 12th 19th, and 26th, 2018

INFORMATION FOR BIDDERS

BIDS will be received by the CITY OF RAMSEY (hereinafter called the "OWNER") at the Ramsey Municipal Center, 7550 Sunwood Drive NW, Ramsey, MN 55303 until February 5th, 2018, at 10:30 a.m., and then at said office publicly opened and read aloud.

Each BID must be submitted in a sealed envelope, addressed to Parks Superintendent Mark Riverblood, at the City of Ramsey. Each sealed envelope containing a BID must be plainly marked on the outside as "IP 18-08; Trott Brook Boardwalk" and the envelope shall bear on the outside the name of the BIDDER, and their address and license number if applicable. If mailed, bids should be placed in a separate envelope and mailed to the City address noted above to the attention of Parks Superintendent Mark Riverblood.

All BIDS must be made on the required BID FORM. All blank spaces for BID prices must be filled out in ink or typewritten and the BID FORM must be fully completed and executed when submitted. Only one (1) copy of the BID FORM is required.

The OWNER may waive any informality or minor defects or reject any and all BIDS. Any BID may be withdrawn prior to the above scheduled time for the opening of BIDS or authorized postponement thereof. Any BID received after the time and date specified shall not be considered. No BIDDER may withdraw a BID within forty five (45) days after the actual date of the opening thereof. Should there be reasons why the contract cannot be awarded within the specified period; the time may be extended by mutual agreement between the OWNER and the BIDDER.

BIDDERS must satisfy themselves of the accuracy of the estimated quantities in the BID documents, by examination of the site, the sample boardwalk in place, and a review of the drawings and specifications, including any ADDENDA. After BIDS have been submitted, the BIDDER shall not assert that there was a misunderstanding concerning the quantities of WORK or of the nature of the WORK to be done.

The OWNER shall provide to BIDDERS all information which is pertinent to, and delineates and describes, the land owned and rights-of-way boundaries. The OWNER will provide field stakes delineating the proposed boardwalk alignment during the bidding process.

The CONTRACT DOCUMENTS contain the provisions required for the construction of the PROJECT. Information obtained from an officer, agent or employee of the OWNER or any other person shall not affect the risks or obligations assumed by the CONTRACTOR or relieve the CONTRACTOR from fulfilling any of the conditions of the contract.

Each BID must be accompanied by a BID BOND for at least five percent (5%) of the total amount of the BID, made payable to the City of Ramsey. As soon as the BID prices have been compared, the OWNER will return the BONDS of all except the three (3) lowest responsible BIDDERS. When the AGREEMENT is executed, the BONDS of the two remaining unsuccessful BIDDERS will be returned. The BID BOND of the successful BIDDER will be retained until all materials are on

City Property and/or the project is substantially complete. **A certified check may be used in lieu of a BID BOND.**

The party to whom the contract is awarded will be required to execute the AGREEMENT and within ten (10) calendar days from the date when NOTICE OF AWARD is delivered to the BIDDER. The NOTICE OF AWARD shall be accompanied by the necessary AGREEMENT and forms. In case of failure of the BIDDER to execute the AGREEMENT, the OWNER may at its option consider the BIDDER in default; in which case the BID BOND accompanying the proposal shall become the property of the OWNER.

The OWNER, within ten (10) days of receipt of an acceptable AGREEMENT signed by the party to whom the AGREEMENT was awarded, shall sign the AGREEMENT and return to such party an executed duplicate of the AGREEMENT. Should the OWNER not execute the AGREEMENT within such period, the BIDDER may give WRITTEN NOTICE to withdraw his/her signed AGREEMENT. Such notice of withdrawal shall be effective upon receipt of that WRITTEN NOTICE by the OWNER.

The NOTICE TO PROCEED shall be issued within ten (10) days of the execution of the AGREEMENT by the OWNER. Should there be reasons why the NOTICE TO PROCEED cannot be issued within such period; the time may be extended by mutual agreement between the OWNER and CONTRACTOR. If the NOTICE TO PROCEED has not been issued within the ten (10) day period or within the period mutually agreed upon, the CONTRACTOR may terminate the AGREEMENT without further liability on the part of either party.

The OWNER may make such investigations as he/she deems necessary to determine the ability of the BIDDER to perform the WORK and the BIDDER shall furnish to the OWNER all such information and data for this purpose as the OWNER may request. The OWNER reserves the right to reject any BID if the evidence submitted by, or investigation of, such BIDDER fails to satisfy the OWNER that such BIDDER is properly qualified to carry out the obligations of the AGREEMENT and to complete the WORK contemplated therein.

A conditional or qualified BID will not be accepted. Award will be made to the lowest responsible BIDDER.

All applicable laws, ordinances and the rules and regulations of all authorities having jurisdiction over construction of the PROJECT shall apply to the contract throughout.

Each BIDDER is responsible for inspecting the site and for reading and being thoroughly familiar with the CONTRACT DOCUMENTS. The failure or omission of any BIDDER to do any of the foregoing shall in no way relieve any BIDDER from any obligation in respect to their BID.

The low BIDDER shall supply the names and addresses of major material SUPPLIERS and SUBCONTRACTORS when requested to do so by the OWNER.

The OWNER'S representative is Mark Riverblood, Parks Superintendent, 7550 Sunwood Drive NW, Ramsey, MN 55303; telephone (763) 433-9853

SITE LOCATION

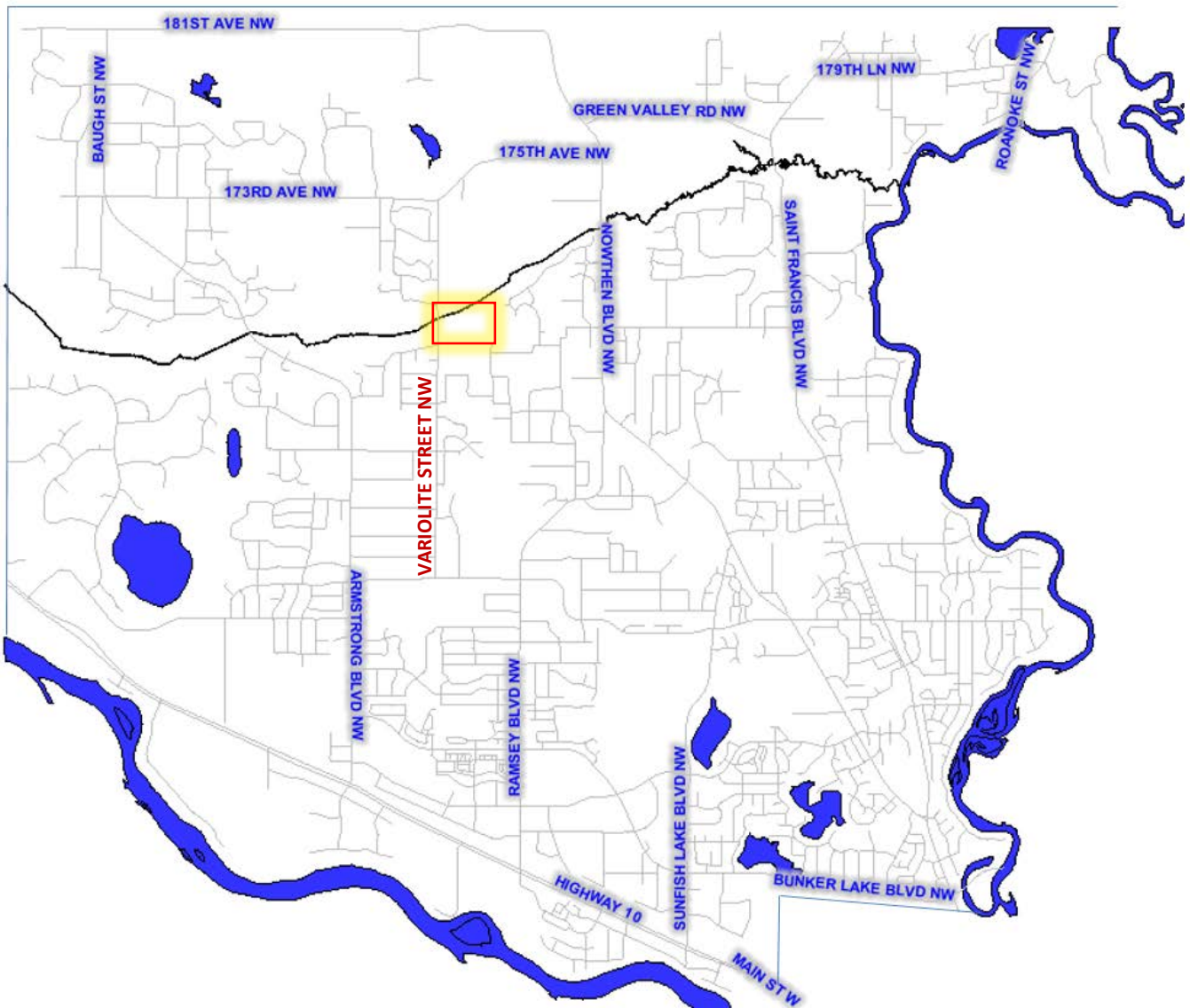
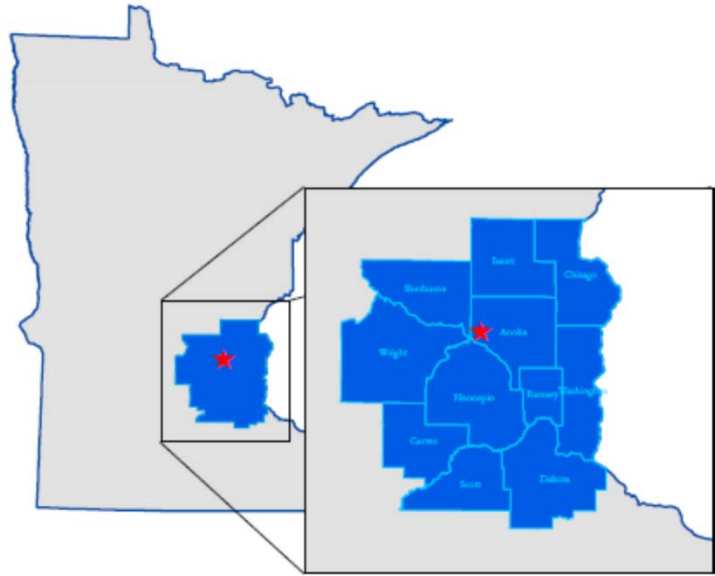

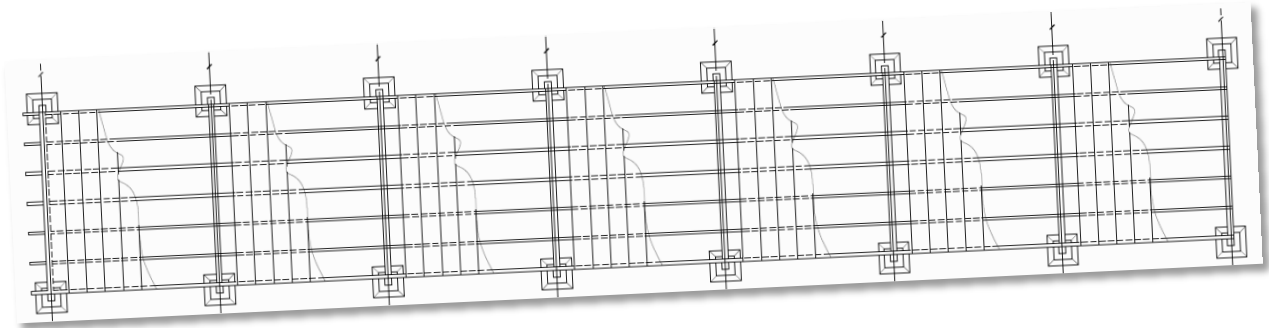
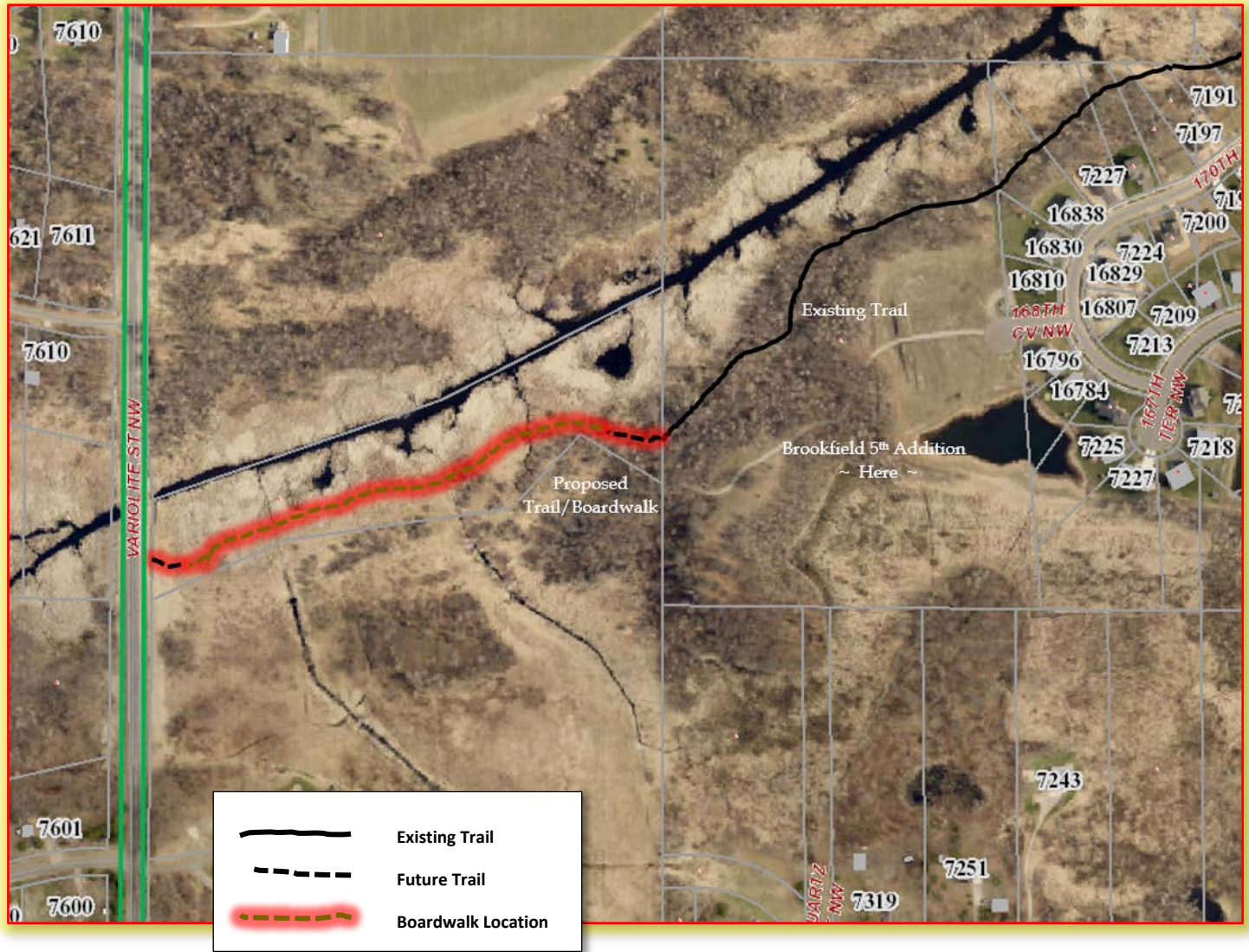

(Boardwalk Plan View)

BID PROPOSAL

This Bid is submitted to the City of Ramsey for City Improvement Project #18-08 - **Trott Brook Boardwalk.**

That _____, the undersigned bidder, proposes and agrees, if this bid is accepted, to enter into an agreement with the Owner in the form included in the contract documents to perform and furnish all work as specified or indicated in the contract documents for the Contract Price and within the contract time indicated in this Bid and in accordance with the other terms and conditions of the contract documents.

In submitting this bid, bidder represents, as more fully set forth in the Agreement, that:

- (a) Bidder has examined copies of all bidding documents and of the following addenda (receipt of all which is hereby acknowledged):

- (b) Bidder has familiarized him/herself with the nature and extent of the contract documents, work, site, locality and all local conditions and laws and regulations that in any manner may affect cost, progress, performance or furnishing of the work.
- (c) Bidder has given the Owner written notice of all conflicts, errors or discrepancies that it has discovered in the contract documents and the written resolution thereof by the Owner is acceptable to bidder.
- (d) This bid is genuine, is not made in the interest of or on behalf of any undisclosed person, firm or corporation, and is not submitted in conformity with any agreement or rules of any group, association, organization or corporation; bidder has not directly or indirectly induced or solicited any other bidder to submit a false or sham bid; bidder has not solicited or induced any person, firm or corporation to refrain from bidding and bidder has not sought by collusion to obtain for itself any advantages over any other bidder or over owner.
- (e) Bidder agrees that the work will be completed by June 1, 2018.
- (f) A bid bond in the amount of five percent (5%) of the bid contained herein is attached. This bid bond shall be forfeited if the bidder fails to execute and file the required contract within ten (10) days after notification of the bid award by the owner.

(g) The contractor agrees to perform all work described in the contract documents for the lump sum payment of the completed boardwalk, **based upon the lineal footage as constructed and accepted.**

BID PROPOSAL

The Trott Brook Boardwalk is estimated to be < 1,500' feet in length when completed, consisting of *approximately* 188, 8' x 8' panels.

ITEM	UNIT	QUANTITY	UNIT PRICE	EXTENSION
BOARDWALK @ 8 FEET WIDE	LF	1,500'	\$ _____	\$ _____
TOTAL BID				\$ _____

This Bid Submitted by:

If Bidder is:

An Individual

Name (typed or printed): _____

By: _____ (SEAL)
(Individuals Signature)

Doing Business as: _____

A Partnership

Partnership Name: _____
(SEAL)

By: _____
(Signature of general partner - attach evidence of authority to sign)

Name (typed or printed): _____

A Corporation

Corporation Name: _____
(SEAL)

State of Incorporation: _____

Type: _____

By: _____
(Signature of general partner - attach evidence of authority to sign)

Name (typed or printed): _____

Title: _____
(CORPORATE SEAL)

Attest: _____
(Signature of Corporate Secretary)

Date of Qualification to do business in Minnesota is: _____

A Joint Venture

Name of Joint Venture: _____
(SEAL)

First Joint Venturer Name: _____

By: _____
(Signature of first joint venture partner - attach evidence of authority to sign)

Name (typed or printed): _____

Title: _____

Second Joint Venturer Name: _____

By: _____
(Signature of second joint venture partner - attach evidence of authority to sign)

(Each joint venture must sign. The manner of signing for each individual, partnership, and corporation that is party to the joint venture should be in the manner indicated above.)

Bidders Business Address: _____

Phone: _____

Submitted on _____, 2018

State Contractor License No. _____. (If Applicable)

RESPONSIBLE CONTRACTOR

In accordance with Laws of Minnesota, 2014, chapter 253 (Minnesota Statutes §16C.285), Bidders are hereby advised that the Department cannot award a construction contract in excess of \$50,000 unless the contractor is a “responsible contractor” as defined in Minnesota Statutes §16C.285, subdivision 3. A bidder submitting a Proposal for this Project must verify that it meets the minimum criteria specified in Minnesota Statutes §16C.285, subdivision 3, by completing the Responsible Contractor Certificate within this Proposal. Statements in the certificate must be certified by a company officer. Bidders are responsible for obtaining verifications of compliance from all subcontractors, using a form provided by the Department. A bidder must submit signed verifications from subcontractors upon the Department’s request.

A Bidder or subcontractor who does not meet the minimum criteria established in Minnesota Statutes §16C.285, subdivision 3, or who fails to verify compliance with the minimum requirements, will not be a “responsible contractor” and will be ineligible to be awarded the Contract for this Project or to work on this Project. Bidders and subcontractors are also advised that making a false statement verifying compliance with any of the minimum criteria will render the Bidder or subcontractor ineligible to be awarded a construction contract for this Project and may result in the termination of a contract awarded to a Bidder or subcontractor that makes a false statement.

STATE OF MINNESOTA - RESPONSIBLE CONTRACTOR CERTIFICATE

Applies to all prime contracts in excess of \$50,000

A responsible contractor is defined in Minnesota Statutes §16C.285, subdivision 3.

Any prime contractor or subcontractor who does not meet the minimum criteria under Minnesota Statutes §16C.285, subdivision 3, or who fails to verify that it meets those criteria, is not a responsible contractor and is not eligible to be awarded a construction contract for the project or to perform work on the project.

A false statement under oath verifying compliance with any of the minimum criteria shall render the prime contractor or subcontractor that makes the false statement ineligible to be awarded a construction contract for the project and may result in termination of a contract awarded to a prime contractor or subcontractor that makes a false statement.

A prime contractor shall submit to the contracting authority upon request copies of the signed verifications of compliance from all subcontractors of any tier pursuant to subdivision 3, clause 7.

By signing this statement, I, _____ (typed or printed name),
_____ (title), certify that I am an owner or officer of the company
and do verify under oath that my company is in compliance with each of the minimum criteria
listed in the law.

(name of the person, partnership or corporation submitting this proposal)

(business address)

Signed: _____
(bidder or authorized representative)

Date

BID SPECIFICATIONS

1. Project Scope:

The Trott Brook Boardwalk is estimated to be 1,500' feet when completed, consisting of *approximately* 188, 8' x 8' panels, each made with 7, 2 x 8 'rails' or joists, with an 8' foot 'cap' on each end (as shown below). Each section shall be through-bolted in at least four places to the adjoining section. The boardwalk will have 4 or 5, (approximately 22 degree or less) turns.

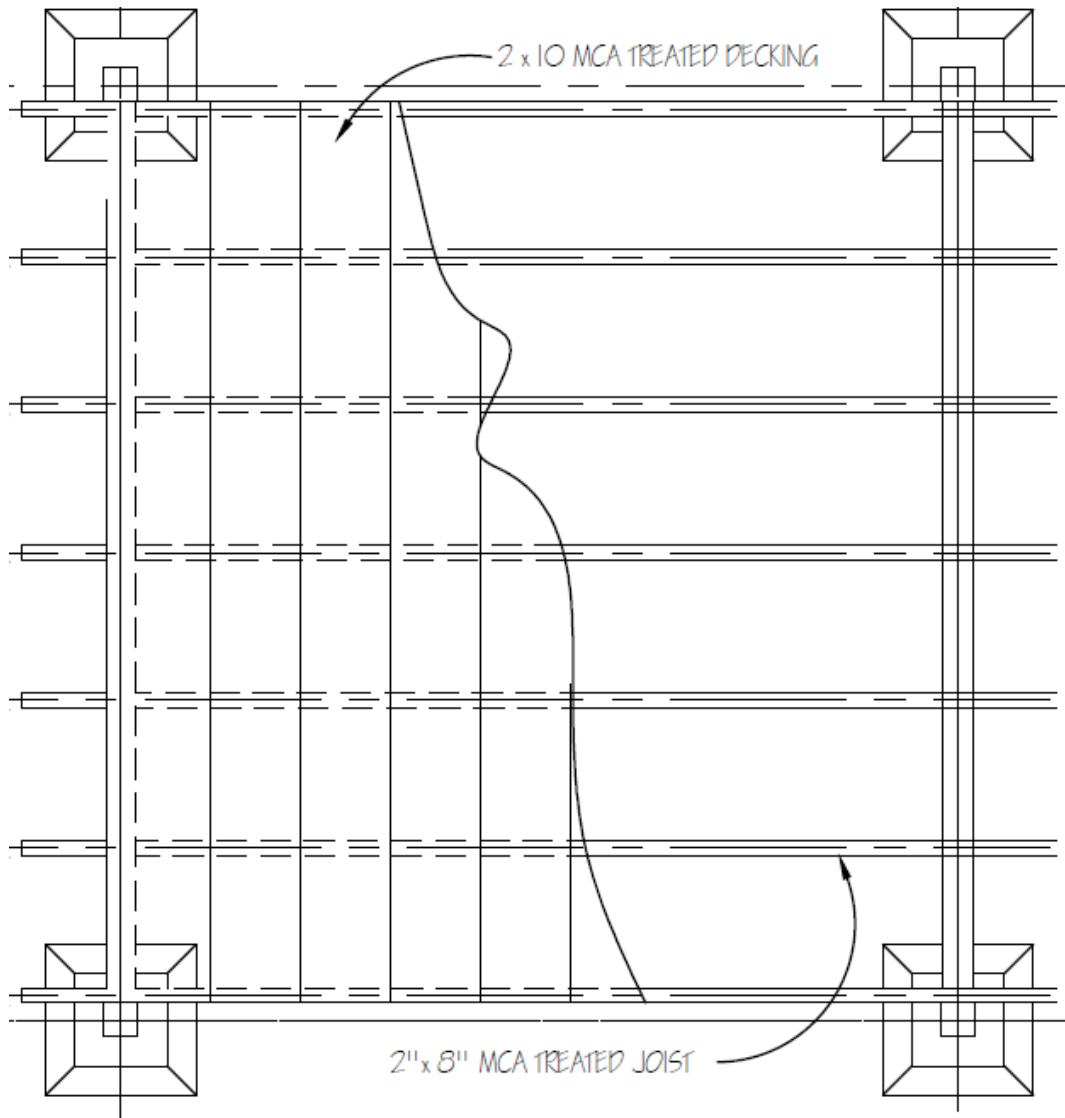

Traverse decking shall consist of 2 x 10's, with an elevated 2 x 4 'curb' on each edge. Each section shall be elevated and supported by galvanized brackets and pans as shown, with a clearance below the deck of between 12" and 24" (varies), to account for uneven ground and to allow the passage of animals.

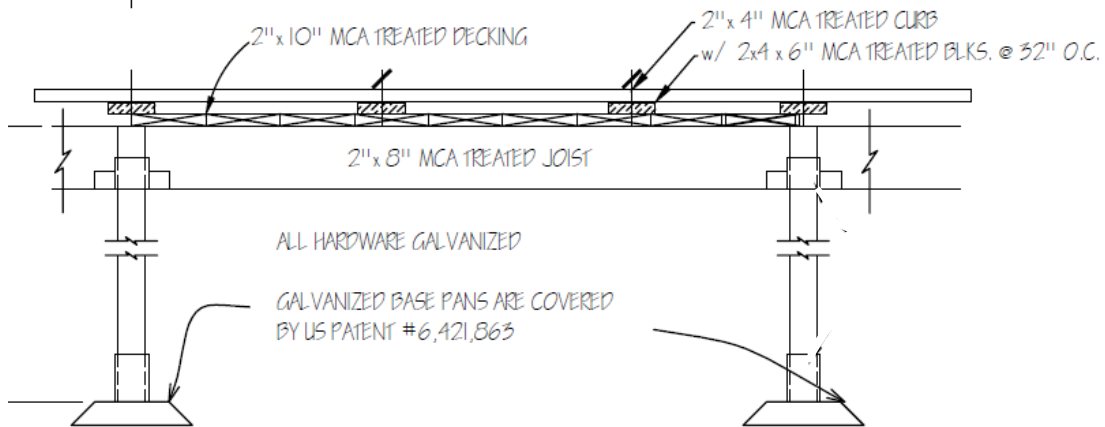

Elevated Curb Detail Above



Hot dipped galvanized footing support pans and 4 x 4 brackets manufactured by Custom Manufacturing Inc., or approved equal.

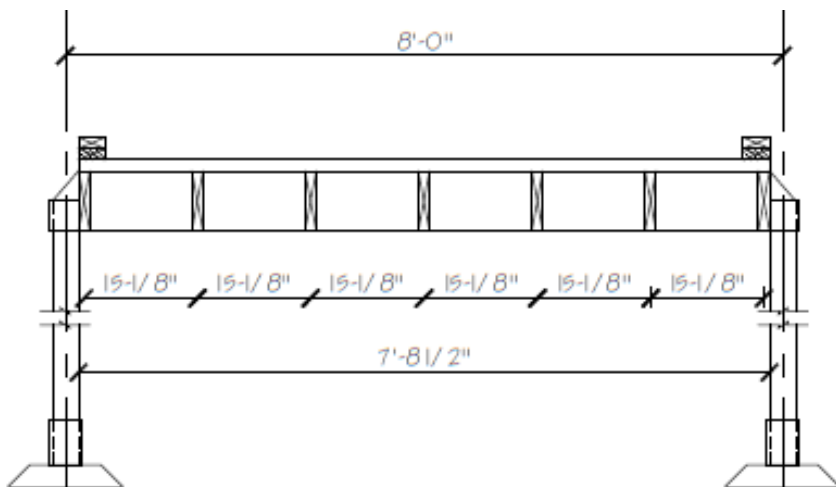

12" to 24" Varies (boardwalk deck surface to remain level)

2. Boardwalk design Loads:

- ~ Design Dead Load on Deck 10 PSF
- ~ Design Live Load on Deck 40 PSF

3. Material Specifications: All materials shall meet or exceed the following specifications:

~ Structural dimensional lumber shall be No. 2 Southern Pine or better, and be graded in accordance with National Design Specifications for wood construction. All lumber shall conform to the requirements of the applicable grading rules agency – a grading agency certification is required on all lumber material. *No warped lumber shall be used.*

~ All wood used shall be arsenic free and ACQ or MCA treated to UC4A standards for ground contact (4 x 4 supports) and UC3B for all other lumber.

~ *All hot dipped galvanized footing support pans (standard size) and 4 x 4 brackets (pictured above) shall be manufactured by Custom Manufacturing Inc. of Clinton, Wisconsin or approved equal.*

~ Joist hangers (10, per 8' x 8' panel) and inside corner brackets (4, per 8' x 8' panel) shall be galvanized or zinc coated.

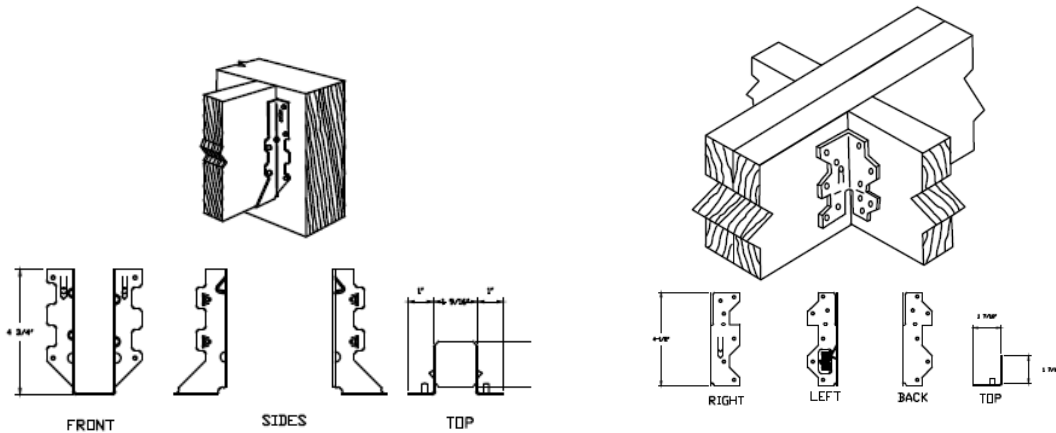

~ All lumber shall be pre-stained brown, or stained brown on site.

~ Deck with ¼ x 3 ½ GRK Structural Screws- Climetek Finish, or approved equal.

In any event of a discrepancy within these specifications, or an instance of an omission in details, the existing boardwalk depicted at the beginning of this document (within the City of Ramsey), shall be consulted for guidance in the interpretation of materials, or methods of construction.

4. Construction Methods:

All material shall be well manufactured. All lumber shall be straight, well sawn, sawed square at ends, and opposite surfaces parallel unless otherwise specified (E.g. 22 degree corners). Workmanship shall be first class throughout. All screws shall be properly set to ensure the heads are flush or *slightly* recessed with the surface of the wood decking. Proper pre-drilling of holes for screws (as may be necessary) shall be performed to avoid splitting the lumber.

All construction is intended to be from the West, at Variolite Street and progress East to the project termini.

5. Basis of Payment:

Payment for the boardwalk shall be made based upon the lineal foot, as measured with the Owner upon completion; and include all costs associated with fabrication, construction/installation and include material delivery, mobilization, with any other costs considered incidental.

CITY SPECIAL PROVISIONS

1. General

These Special Provisions contain items of specific instruction and subject matter concerning construction detail and/or are modifications to the General Conditions and Standard Specifications. The Contractor shall conduct his/her work in conformance with the specifications set forth herein and in accordance with the Minnesota Department of Transportation Standard Specifications for Construction (as may be applicable), 2016 Edition, which is incorporated by reference to these specifications.

2. Project Schedule

The City of Ramsey anticipates, but does not guarantee award of this project, on February 12th, 2018. Construction is foreseen to commence on or about February 26th, 2018.

3. Working Hours

The work shall be carried out during normal daylight working hours in accordance with local ordinance and so as not to cause any unreasonable nuisance to affected residents. Under emergency conditions, this limitation may be waived in writing by the Owner. Normal working hours in the City of Ramsey are considered to be from 7:00 a.m. to 10:00 p.m. on Monday through Saturday. The contractor shall provide 72 hour advance notice before working on Saturday. City Council approval is required for Sunday work.

4. Maintenance of Traffic

All traffic control devices **if required**, shall conform and be installed in accordance to:

- The “Minnesota Manual on Uniform Traffic Control Devices” (MN MUTCD);
- Part 6, “Field Manual for Temporary Traffic Control Zone Layouts” (Field Manual);
- The Speed Limits in Work Zones Guideline;
- The Minnesota Flagging Handbook;
- The Minnesota Standard Signs Manual;
- The Traffic Engineering Manual;

The Contractor shall submit the proposed traffic control layout, to the Owner for approval at least five (5) days prior to the start of construction. The Contractor shall modify his/her proposed traffic control layout and/or devices as deemed necessary by the Owner.

The Contractor shall notify the local Police and Fire Departments prior to commencing construction that will restrict traffic on any City street to the degree that emergency traffic could not be immediately facilitated. The Contractor shall provide necessary signs, flashers and barricades for any parking or driving lane closures. All signing shall conform to the MnDOT Manual of Uniform Traffic Control Devices. All plans for lane closures shall be submitted to the Owner for approval prior to any closures.

The cost of all work related to continuation and control of traffic, including maintenance of traffic, provision of continued access, and the placement, maintenance or removal of traffic control devices should be included within the bid for the boardwalk's construction as incidental. In the event the Contractor fails to maintain the street free of debris or provide signing, the Owner may perform the work and deduct the cost from any amount due the Contractor.

5. Cleanup and Restoration

When the work has been completed, the Contractor shall remove from the site all extra materials, equipment, debris and other supplies. All surfaces disturbed during the construction period shall be returned to their original condition or better.

6. Work Area

The Contractor's operations shall be confined to the Public Park (wetland) and adjoining Right of Way of Variolite Street. The Contractor shall secure the permission of the Owner if he/she wishes to store materials, vehicles and equipment elsewhere.

7. Permits

The Contractor will be required to obtain a City contractor's license.

8. Barricades, Guards and Safety Equipment

To protect persons from injury and to avoid property damage, adequate barricades, construction signs, warning lights, and guards as required shall be placed and maintained by the contractor during the progress of the construction work near Variolite Street. All materials which may serve as obstructions to traffic or be deemed hazards shall be enclosed by fences or barricades and shall be protected by adequate lighting when visibility is poor. The rules and regulations of local authorities respecting safety provisions shall be observed.

9. Preconstruction Conference Required

Prior to initiating the work a preconstruction conference shall be scheduled and held with the contractor and his/her subcontractors (if any), the City, or others with an interest in the project. The Contractor shall prepare and submit a list of subcontractors, material suppliers, and material submittals that are required to comply with specified standards if requested, and will submit certificates of compliance or a schedule for compliance submittal.

No work is authorized on the project until the Notice to Proceed is issued. Once work has commenced, the Contractor shall continuously pursue completion in accordance with the approved schedule.

10. Construction Staking

Boardwalk alignment staking shall be provided by the Owner. Confirmation of the alignment and locations of 4 or 5 turns will be verified in the field, together with the Owner and Contractor. The Contractor shall be responsible for compliance with ADA requirements of the boardwalk (vertical separation, side slopes and grade elevation transitions).

11. Protection of Utilities

The Contractor is advised that utilities which include electric, gas, telephone, cable TV, fiber optic lines, and water and sanitary sewer may be located within the project area near Variolite Street. The Contractor shall comply with the provisions of Minnesota Statutes Chapter 216 related to underground construction and utility protection (Gopher State One call).

12. Maintenance during Construction

Once the Contractor commences work on the project, the construction area shall be maintained for the remainder of the project by the Contractor at their expense. Necessary signs and barricades shall be furnished by the Contractor. The Contractor is required to place a portable biffy on site, or mandate that all workers utilize the restrooms at Central Park.

13. Basis of Payment and Project Acceptance

Payment shall be made for the work performed, upon the lineal measurement of the centerline of the actual boardwalk constructed. The cost of any additional labor materials, tools and supplies which have not been specifically identified but required to complete the project as per the plans and specifications shall be considered incidental to the project as bid.

The project will be accepted and approved at the completion of all aspects of the construction, with the Owner and Contractor walking the boardwalk and finding that there is NO perceptible movement latterly or vertically, nor sounds of movement.

CONSTRUCTION CONTRACT

THIS AGREEMENT (the "Agreement") is made and entered into this ____ day of _____, 2018, by _____ and _____ between _____, a Minnesota Corporation (the "Contractor") and the City of Ramsey, a Minnesota Municipal Corporation, 7550 Sunwood Drive NW, Ramsey, Minnesota 55303 (the "Owner").

WITNESSETH

WHEREAS, the City of Ramsey proposes to construct an 8' foot wide wooden boardwalk, approximately 1,500' feet in length, with City Improvement Project No. 18-08 (the "Project"); and

WHEREAS, the plans and specifications necessary for construction of the Project are defined in the Contract Documents and Technical Specifications dated _____, 2018 (the "Contract Documents"); and

WHEREAS, the work required to complete the Project is defined in the Contract Documents (the "Work"); and

WHEREAS, the Contractor has made a written proposal and bid to the Owner to furnish the material, equipment, labor and everything necessary for the completion of the Work for the price and within the time schedule required by the Contract Documents; and

WHEREAS, the Contractor, as the lowest responsible bidder, has been awarded the contract for the Work by the City; and

WHEREAS, Contractor, in consideration of the payments hereinafter provided, for itself and its successors, as the case may be, hereby covenants and agrees to and with the Owner to perform the Work and furnish the material, under the supervision of the City Engineer; and

WHEREAS, Contractor acknowledges:

1. That it understands the Contract Documents;
2. That it has the equipment, technical ability, personnel and facilities to construct the Project in accordance with the Contract Documents and that it is licensed by all applicable agencies and governmental entities;

3. That the Contract Documents are, in its opinion, appropriate and adequate for the complete construction of the Project in a sound and suitable manner.

NOW, THEREFORE, in consideration of the mutual covenants contained herein, it is agreed and understood as follows:

1. Work Performance. Contractor shall perform the Work as described in the Contract Documents which are incorporated herein by reference. Contractor agrees to comply with all federal, state, and local laws and ordinances applicable to the services to be performed under this Agreement, including all safety standards. The Contractor shall be solely and completely responsible for conditions of the job site, including the safety of all persons and property during the performance of the services.
2. Commencement of Work. The Contractor shall commence work on the Project within ten (10) days of the date of the Notice to Proceed given by the City Engineer and shall have the Work substantially complete within the period specified in the Contract Documents. Failure to complete the work within this period will be cause for the Contractor to forfeit the amount as required by the Special Provisions terms of the Contract Documents and that it is appropriately licensed by all applicable agencies and governmental entities.
3. Contractor Compensation. The Owner shall compensate Contractor for the Work in the amount of \$_____ per lineal foot based upon the Contractor's accepted bid subject to any additions or deductions provided therein, payment shall be made pursuant to the payment provisions outlined in the Contract Documents.
4. Independent Contractor Relationship. It is expressly understood that the Contractor is an "independent contractor" and not an employee of the City. The Contractor shall have control over the manner in which the services are performed under this Agreement. The Contractor shall supply, at its own expense, all materials, supplies, equipment and tools required to accomplish the work contemplated by this Agreement. The Contractor shall not be entitled to any benefits from the City, including, without limitation, insurance benefits, sick and vacation leave, workers' compensation benefits, unemployment compensation, disability, severance pay, or retirement benefits.
5. Insurance Requirements.
 - A. Liability. The Contractor agrees to maintain commercial general liability insurance in a minimum amount of \$1,500,000 per occurrence; \$2,000,000 annual aggregate. The policy shall cover liability arising from premises,

operations, products-completed operations, personal injury, advertising injury, and contractually assumed liability. The City shall be named as an additional insured.

- B. Automobile Liability. If the Contractor operates a motor vehicle in performing the services under this Agreement, the Contractor shall maintain commercial automobile liability insurance, including owned, hired, and non-owned automobiles, with a minimum liability limit of \$1,000,000, combined single limit.
 - C. Workers' Compensation. The Contractor agrees to comply with all applicable workers' compensation laws in Minnesota.
 - D. Certificate of Insurance. The Contractor shall, prior to commencing services, deliver to the City a Certificate of Insurance as evidence that the above coverage's are in full force and effect.
6. Indemnification. To the fullest extent permitted by law, the Contractor agrees to defend, indemnify and hold harmless the City, and its employees, officials, volunteers and agents from and against all claims, actions, damages, losses and expenses, including attorney fees, arising out of the Contractor's negligence or the Contractor's performance or failure to perform its obligations under this Agreement. The Contractor's indemnification obligation shall apply to the Contractor's subcontractor(s), or anyone directly or indirectly employed or hired by the Contractor, or anyone for whose acts the Contractor may be liable. The Contractor agrees this indemnity obligation shall survive the completion or termination of this Agreement.
7. Dispute Resolution. The Parties shall cooperate and use their best efforts to ensure that the various provisions of the Agreement are fulfilled. The Parties agree to act in good faith to undertake resolution of disputes, in an equitable and timely manner and in accordance with the provisions of this Agreement. If disputes cannot be resolved informally by the Parties, the following procedures shall be used:
- A. Whenever there is a failure between the Parties to resolve a dispute on their own, the Parties shall first attempt to mediate the dispute. The parties shall agree upon a mediator, or if they cannot agree, shall obtain a list of court-approved mediators from the Anoka County District Court Administrator and select a mediator by alternately striking names until one remains. The City shall strike the first name followed by the Contractor, and shall continue in that order until one name remains.
 - B. Litigation. If the dispute is not resolved within thirty (30) days after the end of mediation proceedings, the Parties may litigate the matter.

- I. Ownership of Documents. All reports, plans, specifications, data, maps, and other documents produced by the Contractor in the performance of services under this Agreement shall be the property of the City.
- J. Government Data. The Contractor agrees to maintain all data received from the City in the same manner as the City as required under the Minnesota Government Data Practices Act, Minnesota Statutes, Chapter 13.
- K. Counterparts. This Agreement may be signed in counterparts, each of which shall be deemed an original, and which taken together shall be deemed to be one and the same document.
- L. Savings Clause. If any court finds any portion of this Agreement to be contrary to law, invalid, or unenforceable, the remainder of the Agreement will remain in full force and effect.

IN WITNESS WHEREOF, the parties hereto have caused this instrument to be executed in triplicate counterparts the day and year first above written.

CONTRACTOR:

OWNER:

CITY OF RAMSEY

By:_____

By:_____

Sarah Strommen, Its Mayor

Its:_____

ATTEST:

By:_____

Kurt Ulrich, Its City Administrator