

**City of Ramsey**  
**Agenda**  
**Public Works Committee**  
**Tuesday, December 18, 2018**  
**5:30 pm**  
**Lake Itasca Room, 7550 Sunwood Drive NW**

1. **Call to Order**
2. **Citizen Input**
3. **Approve Agenda**
4. **Approve Minutes**
  1. Approve Meeting Minutes.
5. **Committee Business**
  1. Consider Recommendation to City Council to Accept Petition Opposing Improvement Project #19-02, Brookview Estates Street Reconstructions
  2. Consider Request to Modify Traffic Control at Bunker Lake Boulevard, Puma Street and Rabbit Street Intersection.
  3. **Highway 47 Landscaping Project**
6. **Committee/Staff Input**
  1. Review Drainage Concerns at 17290 Germanium Street NW
  2. Staff Updates on Improvement Projects and Items of Interest
  3. Review Future Topics Calendar
7. **Adjournment**

**Public Works Committee**

**4. 1.**

**Meeting Date:** 12/18/2018

**Submitted For:** Grant Riemer, Engineering/Public Works

**By:** MaryJo Warner, Engineering/Public Works

**Title:**

Approve Meeting Minutes.

**Purpose/Background:**

To review and approve the following meeting minutes.

- 1. Public Works Committee dated October 16, 2018
- 2. Public Works Committee dated November 20, 2018

**Timeframe:**

5 minutes.

**Observations/Alternatives:**

n/a

**Funding Source:**

n/a

**Recommendation:**

**Action:**

Motion to approve the following meeting minutes.

- 1. Public Works Committee dated October 16, 2018
- 2. Public Works Committee dated November 20, 2018

**Attachments**

October

November

**Form Review**

<b>Inbox</b>	<b>Reviewed By</b>	<b>Date</b>
Bruce Westby	Bruce Westby	12/11/2018 10:19 AM
Mary Jo Warner (Originator)	MaryJo Warner	12/11/2018 10:30 AM
Bruce Westby	Bruce Westby	12/11/2018 10:48 AM
Grant Riemer	Grant Riemer	12/11/2018 10:50 AM
Kurt Ulrich	Kurt Ulrich	12/11/2018 03:09 PM
Form Started By: MaryJo Warner		Started On: 11/27/2018 11:20 AM
Final Approval Date: 12/11/2018		

**PUBLIC WORKS COMMITTEE  
CITY OF RAMSEY  
ANOKA COUNTY  
STATE OF MINNESOTA**

The Public Works Committee conducted a regular meeting on Wednesday, October 16, 2018, at the Ramsey Municipal Center, 7550 Sunwood Drive NW, Ramsey, Minnesota.

Members Present:     Chairperson Chris Riley  
                              Councilmember Jill Johns

Members Absent:     Councilmember Mark Kuzma

Also Present:         Public Works Superintendent Grant Riemer  
                              City Engineer Bruce Westby

**1.     CALL TO ORDER**

Chairperson Riley called the regular meeting of the Public Works Committee to order at 5:30 p.m.

**2.     CITIZEN INPUT**

There was none.

**3.     APPROVE AGENDA**

Motion by Councilmember Johns, seconded by Chairperson Riley, to approve the agenda, as presented.

Motion carried. Voting Yes: Chairperson Riley and Councilmembers Johns. Voting No: None. Absent: Councilmember Kuzma.

**4.     APPROVE MINUTES**

**4.01:   Approve August 21, 2018, Meeting Minutes**

Motion by Councilmember Johns, seconded by Chairperson Riley, to approve the following minutes:

Regular Meeting Minutes dated August 21, 2018

Motion carried. Voting Yes: Chairperson Riley and Councilmembers Johns. Voting No: None. Absent: Councilmember Kuzma.

## **5. COMMITTEE BUSINESS**

### **5.01: Consider Recommendation to City Council Supporting Metropolitan Council Study for Northwest Metropolitan Area Regional Surface Water Supply Facility**

City Engineer Westby stated that Metropolitan Council staff have long been aware that the City of Ramsey has explored the use of surface water to augment, or even possibly replace, our groundwater supply sources for our municipal water supply. More than a year ago, staff from the Metropolitan Council informed City staff that funds were available to conduct a study to explore the feasibility of constructing a regional surface water supply facility in the northwest metro area, and asked if staff was aware of any other cities that might be interested in partnership with us to explore the feasibility of a regional surface water supply facility.

City Engineer stated that since then, staff contacted their counterparts in neighboring cities in Anoka County to discuss the possibility of partnering with us on a regional surface water supply facility. Those discussions were not fruitful. Then recently, staff was informed that the cities of Dayton and Rogers might be interested in partnering in such a study. Staff was later informed that the City of Corcoran might also be interested. Staff has since informed Metropolitan Council staff that three other cities have expressed an interest in partnering with us, at which time Metropolitan Council staff asked if each City would be able to adopt supporting resolutions, which Metropolitan Council staff would then use to request funding for the study on their end.

City Engineer Westby reported that staff from each partnering city plans to request City Council adoption of a supporting resolution at the earliest opportunity. For the City of Ramsey, staff proposes to request adoption of a supporting resolution at the October 23<sup>rd</sup> City Council meeting. He recommended approving a recommendation to the City Council to adopt a resolution supporting a Metropolitan Council study for a Northwest Metropolitan area regional surface water supply facility.

Chairperson Riley asked the reasons why some other cities do not want to participate.

City Engineer Westby replied that some cities have their own systems and do not feel that they would benefit from this study. He stated that some of the more rural cities are simply content with their current system or do not have their own water supply systems.

Councilmember Johns asked if Elk River has its own system.

City Engineer Westby replied that Elk River uses a private water utility to supply their water. He stated that this would be a partnership of four cities to determine what the costs would be to determine if there would be a feasible and affordable option. He stated that if the costs appear to be reasonable for a regional facility, he would expect each of the four cities to reach out again to determine if there would be additional interest. He explained that this is simply a planning study that will allow more information to be gathered for planning a future regional water supply facility.

Chairperson Riley stated that in the past the City was required to look at this and asked if other cities have been required to look at this topic as well.

City Engineer Westby confirmed that Ramsey was forced to look at the topic because of the location on the sandplain.

Chairperson Riley stated that he would prefer to keep Ramsey separate from the Metropolitan Council if possible.

Councilmember Johns stated that she would support the recommendation of staff.

City Engineer Westby stated that this would not open the City up to anything or future commitments. He understood that some people are guarded in their interaction with the Metropolitan Council. He stated that in his experience with the Metropolitan Council he was able to further understand the limitations on the reach that organization has. He stated that the Metropolitan Council is charged by legislation to assist cities in planning efforts for water supply and the organization cannot compel cities to do anything.

Councilmember Johns stated that the requirement was to have a regional partnership/solution and therefore perhaps this would meet that requirement.

Chairperson Riley noted that this will move forward to the City Council, noting that there are only two members present tonight that may not agree on the decision.

Councilmember Johns asked and received confirmation that the other cities involved would use the same resolution.

City Engineer Westby stated that the Metropolitan Council holds the funds from the Clean Water Fund. He explained that the Metropolitan Council is attempting to lessen its role in the process and allow the cities to take the lead.

Chairperson Riley stated that he will not be supporting this action and therefore suggested that the action be to send this forward to the City Council for review.

Motion by Chairperson Riley, seconded by Councilmember Johns, to pass the review of the resolution allowing the Metropolitan Council to complete a study for a Northwest Metropolitan area regional surface water supply facility to the City Council without a recommendation.

Motion carried. Voting Yes: Chairperson Riley and Councilmembers Johns. Voting No: None. Absent: Councilmember Kuzma.

## **6. COMMITTEE / STAFF INPUT**

### **6.01: Update on Status of Feasibility Reports for 2019 Street Reconstruction Projects**

Councilmember Johns asked and received confirmation that 2019 is the last year of the street reconstruction and overlay program.

City Engineer Westby confirmed that staff will bring forward a new five-year plan during 2019 for review which will include seven to ten years of projects.

Chairperson Riley asked if that would provide additional flexibility for staff.

Public Works Superintendent Riemer confirmed that would provide the flexibility needed to include roads that may deteriorate faster than others during that cycle.

City Engineer Westby provided an update on the status of Feasibility Reports for the 2019 Street Reconstruction Projects beginning with Improvement Project #18-02, HY-10 Ramsey, Street Reconstruction. He stated that a public input meeting was held on September 13<sup>th</sup> and a notification was sent out prior to the property owners. He stated that he did not receive any comments, and no one attended the meeting. He reported that about one week ago he received a call from two property owners that object to the HY-10 Ramsey project. He stated that the property owners noted that there is a possibility of redevelopment in that area and perhaps that improvement project should be delayed until that future redevelopment project occurs. He noted that the two property owners have commercial use with little or no customer access and therefore the road conditions do not bother them and there have not been complaints on the project. He stated that one option to move forward would be to simply complete intersection improvements in that area and pothole patching on the rest of the project which could then be maintained annually. He estimated a cost of about \$8,000 or less compared to the \$290,000 for the proposed project. He confirmed that there is minimal use of the roadway and therefore staff recommends shelving this project and completing minor pavement repairs in 2019, allows streets to be limped along as best as practical for another five to ten years due to the high potential for redevelopment and objections received from the property owners.

Councilmember Johns stated that she agrees that this should be postponed until redevelopment occurs as long as the property owners are in agreement and the road is safe for public works and emergency vehicles. She stated that there is a lot of property for sale in that area and a high potential for redevelopment.

Chairperson Riley agreed. He stated that he appreciated the plan that had limited improvements but agreed that limiting the improvements further would be beneficial as the property owners object to the project.

City Engineer Westby confirmed the consensus of the Committee to support the staff recommendation to postpone Improvement Project #18-02 HY-Ramsey, Street Reconstructions.

City Engineer Westby provided an update on the Feasibility Reports for the 2019 Street Reconstruction Projects including Improvement Project #19-01, Ford Brook Estates Street Reconstructions; Improvement Project #19-02, Brookview Estates Street Reconstructions; and Improvement Project #19-03, Wood Pond Hills & Chestnut Ridge Street Reconstructions. He

noted that he will bring forward the proposed improvement projects as discussed for City Council review.

#### **6.02: Staff Updates on Improvement Projects and Items of Interest**

City Engineer Westby provided an update on improvement projects and items of interest.

#### **6.03: Review Future Topics Calendar**

City Engineer Westby stated that staff has been updating the calendar included in the packet, noting that some of the items have been postponed because of the development projects. He reviewed some of the topics that he hopes to bring forward at the next few meetings. It was determined that Finance Director Lund should be invited to a future meeting in order to assist in a budget related discussion.

### **7. ADJOURNMENT**

Motion by Councilmember Johns, seconded by Chairperson Riley, to adjourn the Public Works Committee meeting.

Motion carried.

The regular meeting of the Public Works Committee adjourned at 6:34 p.m.

Respectfully submitted,

---

Grant Riemer  
Public Works Superintendent

Drafted by Amanda Staple  
*TimeSaver Off Site Secretarial, Inc.*

**PUBLIC WORKS COMMITTEE  
CITY OF RAMSEY  
ANOKA COUNTY  
STATE OF MINNESOTA**

The Public Works Committee conducted a regular meeting on Tuesday, November 20, 2018, at the Ramsey Municipal Center, 7550 Sunwood Drive NW, Ramsey, Minnesota.

Members Present:     Chairperson Chris Riley  
                              Councilmember Mark Kuzma

Members Absent:     Councilmember Jill Johns

Also Present:         Public Works Superintendent Grant Riemer  
                              Parks and Assistant Public Works Superintendent Mark Riverblood  
                              City Engineer Bruce Westby  
                              Debra Musgrove  
                              Planning Commissioner Bruce Anderson

**1.     CALL TO ORDER**

Chairperson Riley called the regular meeting of the Public Works Committee to order at 5:30 p.m.

**2.     CITIZEN INPUT**

There was none.

**3.     APPROVE AGENDA**

Motion by Councilmember Kuzma, seconded by Chairperson Riley, to approve the agenda, as presented.

Motion carried. Voting Yes: Chairperson Riley and Councilmember Kuzma. Voting No: None. Absent: Councilmember Johns.

**4.     APPROVE MINUTES**

**4.01:   Approve October 16, 2018, Meeting Minutes**

Councilmember Kuzma noted that he was not present at the previous meeting and suggested tabling the minutes for consideration to the next meeting.

Motion by Councilmember Kuzma, seconded by Chairperson Riley, to table the following minutes:

Motion carried. Voting Yes: Chairperson Riley and Councilmember Kuzma. Voting No: None. Absent: Councilmember Johns.

## **5. COMMITTEE BUSINESS**

### **5.01: Authorize Architectural Design Services for Municipal Pumphouse #3**

Parks and Assistant Public Works Superintendent Riverblood stated that the City of Ramsey, is presently in process of the design for the remaining major public realm elements in The COR, specifically the two connected park spaces—Municipal Plaza and The Waterfront. Both of these parks are along or near, Center Street and in proximity to Pumphouse #3, with the Ramsey Municipal Center at the southern terminus of this same street. Center Street, as the name implies, is at the very center of Ramsey's pedestrian and transit orientated downtown. The existing and future municipal buildings represent an archipelago of visually and physically interconnected places within the community along this armature and axis of streets, trails, sidewalks and parks—and as such, care should be taken to define and embrace this sense of place through appropriate architecture.

Parks and Asst. Public Works Superintendent Riverblood stated that together with the Municipal Center, the Pumphouse was one of the very first buildings in The COR, however, unlike the Municipal Center, the decision was purposeful to not finish the exterior, preferring to do so at the time that all the public realm elements could be understood and contextualized—which is concurrent with the aforementioned park design, and today.

Parks and Asst. Public Works Superintendent Riverblood noted that since approximately 2005, the city has had this project (finishing the facade of the pumphouse) within the Capital Improvement Program (CIP). The CIP worksheet is shown as the second attachment, and identified as a 2018 project; anticipating the above-described concurrent planning and design activity for, and within the public realm.

Parks and Asst. Public Works Superintendent Riverblood stated that to advance this project, Staff has worked with LHB, one of the City's Consultants to outline a work plan that addresses the primary tasks, and takes into consideration the various aspects of this highly visible project—to ensure the architecture of this building meets aesthetic expectations, is cost effective and sustainable, and contributes appropriately to the functional 'sense of place' in Ramsey's downtown. The third attachment is the Architectural Design Services proposal from LHB.

Parks and Asst. Public Works Superintendent Riverblood recommended moving forward with this project as outlined in the proposal. Proceeding at this time, should provide for design completion by the spring of 2019, allowing for the Public Works Committee and City Council to consider completion (physical construction) of the exterior of Pumphouse #3 later in 2019.

Councilmember Kuzma asked the balance of the Municipal Water Utility Fund and whether there are sufficient funds for this.

Parks and Asst. Public Works Superintendent Riverblood stated that he is not aware of the specific fund balance but noted that it is in the millions, and revenue is on-going by water utility purchases of water.

Councilmember Kuzma asked and received confirmation that the Municipal Water Utility Fund can only be used for project related to utilities.

Chairperson Riley asked why the City would not instead ask for proposals where the builder would come to the City with their proposals rather than preparing this work and then going out to builders.

Parks and Asst. Public Works Superintendent Riverblood commented that the City could try that and perhaps one or two responses would come back but he did not think the contractor would be very thoughtful of the overall scope of planning and architectural themes throughout The COR that will come in the future. He believed that the scope of work is an opportunity to think about the entire sense of place and would inform specific architectural detail for the pump house and other municipal infrastructure.

Chairperson Riley stated that Parks and Assistant Public Works Superintendent Riverblood's passion is expressed in his presentation, and believed that could be shared with the contractor. He stated that perhaps a few contractors are brought in and that passion is shared, and this information is shared, and the contractors are directed to provide different options. He believed that staff already did a large amount of the work.

Debra Musgrove, future Councilmember, asked and received confirmation that the purpose of the project is not to change the function or inside of the building but to change the outside aesthetic.

Parks and Asst. Public Works Superintendent Riverblood replied that the big takeaway would be the various studies, sketches, concepts, and options that would lead up to a final color rendering in detail. He stated that contractors may be willing to do the rendering but noted that it is a costly endeavor that most contractors are not going to want to do this without being reimbursed for the cost. He stated that the same design/build process was done with the monuments for The Draw, which asked contractors for three options. He stated that he can attempt to get contractors to respond to a request for proposals but is not confident that the City will obtain quality responses. He stated that the process he is proposing would load the work on the front end in attempt to minimize the work needed by the contractor in the end.

Bruce Anderson, Planning Commissioner, stated that the Planning Commission has spent a lot of time talking about buildings' appearance in The COR. He believed that it would be beneficial for the Parks Commission and Public Works Committee to work together on things of this nature. He believed that The COR should have a consistent architectural theme that carries throughout. He stated that perhaps the Planning Commission should also provide input on the topic and what The COR is going to look like.

Parks and Asst. Public Works Superintendent Riverblood agreed that the approach should be thoughtful. He explained that he would not necessarily want the pump house to match an apartment building within The COR but to be consistent and complementary with respect to the civic architecture throughout The COR. He stated that the architecture should define the look and 'feel' of public spaces so that the members of the public are aware of the spaces that are available for the public to rest or enjoy.

Councilmember Kuzma stated that he recently visited US Bank Stadium and was amazed at the thoughtful planning that was used in terms of architecture. He noted that if you simply put a request to a contractor they are not thinking in terms of great architecture, they will most likely return a low-cost option. He stated that if this is going to be a main piece of The COR, the main elements should be considered, and the architectural input should be gained at this point. He asked and confirmed that the schematic design of the park would also be used in conjunction with this project.

Chairperson Riley stated that if he were going to side his home, he does not design that and then ask a builder to come. He would instead as contractors to come to the site and give them his ideas and then choose the best option. He stated that the criteria can be explained, and the City would have the option to choose from different concepts.

Parks and Asst. Public Works Superintendent Riverblood stated that a residential home already has a drawing completed, and therefore residing is simply using that same architectural design, with the material as the only unknown. He stated that it would take staff time to issue an RFP as well. He explained that an RFP would have to be defined to include the bullet points that were just discussed.

Chairperson Riley stated that he would support the RFP process.

Ms. Musgrove commented that the pumphouse still needs to remain functional for the City workers and asked if access and those elements are also being considered in addition to the aesthetics.

Chairperson Riley stated that functionality is already built into the site as it is used daily.

Parks and Assistant Public Works Superintendent Riverblood confirmed that the tasks listed would identify those elements. He stated that staff is aware of the constraints of the site and the functionality that would need to remain for maintenance activities. He stated that in the process as proposed, staff would work with the consultant. He stated that through the RFP process the consultants may not fully consider all of the elements and staff will need to field a number of questions.

Councilmember Kuzma asked for information on the timeline. He noted that perhaps the City first go through RFP and then if that does not work the other process could be followed.

Parks and Assistant Public Works Superintendent Riverblood stated that it would take a few weeks to develop an RFP and send that out to contractors. He stated that there is also a risk that

contractors spend a large amount of time developing costly plans and if the City changes things, that could turn the contractor off from the project.

Chairperson Riley stated that he is interested in the RFP process. He stated that staff can include the main points within the RFP and the City can then review the concepts that are brought back.

Parks and Asst. Public Works Superintendent Riverblood asked for the opinion of the Committee for an RFP letter of interest, to determine if contractors would be interested in bidding without fully developing an RFP.

Chairperson Riley asked if the City has experience in that and whether that would hurt the cause or help it.

Parks and Assistant Public Works Superintendent Riverblood stated that it is unknown, but he would be interested to know if contractors would even be interested.

Councilmember Kuzma stated that perhaps a premeeting be held with contractors.

Parks and Asst. Public Works Superintendent Riverblood stated that the contractors will not ask mindful questions with other contractors in the room. He stated that could be attempted but would take additional staff time as well.

Chairperson Riley stated that he would support the RFP process in whatever is the smartest way of completing that.

City Engineer Westby stated that engineering issues RFPs all the time but does not have experience in an RFP letter of interest.

Chairperson Riley suggested that staff go through the RFP process which would include a letter of interest and premeeting which would allow questions.

Councilmember Kuzma stated that the only problem is that if a contractor asks questions, staff would not necessarily have the answers at this time. He stated that the City did complete the design build for the fire stations and that has been the City process. He stated that in terms of having available funding set aside, he would support completing the design build process rather than throwing out an RFP and seeing what is returned.

Chairperson Riley stated that having funds is not a reason to spend funds.

Councilmember Kuzma stated that change orders also cost money.

Chairperson Riley stated that he does not see the reasoning in spending \$23,000 in designing a building that will have a cost of \$60,000.

Councilmember Kuzma stated that he could agree with the RFP process to see what happens, as long as that would not stress the timeframe.

It was the consensus of the Committee was to direct staff to initiate an RFP process.

Parks and Assistant Public Works Superintendent Riverblood cautioned the Committee that he will attempt to roll this into staff's workload but there will be additional staff time needed, and the timeframe will be slowed.

Motion by Councilmember Kuzma, seconded by Chairperson Riley, to direct staff to prepare an RFP for Architectural Design Services for Pumphouse #3.

Motion carried. Voting Yes: Chairperson Riley and Councilmember Kuzma. Voting No: None. Absent: Councilmember Johns.

**5.02: Consider Initial Direction on Development of Policy for Private Improvements within Public Rights of Way**

Public Works Superintendent Riemer stated that the purpose of this case is to consider a policy for private improvements within public rights of way. The impetus behind the request is most recently due to a request to amend an existing center median within the Village of Sunfish Lake development. This topic has also been discussed as part of the approval process for current phases of the Brookfield residential development.

Public Works Superintendent Riemer noted that the intent is to provide broad, initial direction for the formulation of a future policy. Primarily, Staff is seeking direction on process and standards. Preliminary talking points are included in the attached framework. This discussion topic is intentionally abstract to ensure that Staff has sufficient policy direction prior to developed a more formalized and detailed policy. Additionally, a request from Sweetbay Ridge to complete a project was approved by the Public Works Committee at the January 17, 2017 meeting and approved by City Council at the February 14th, 2017 meeting.

Public Works Superintendent Riemer recommended that the Public Works Committee adopt a formal policy to address private improvements in public rights of way, to be developed and approved at a subsequent meeting.

Councilmember Kuzma stated that assessments are used for road improvements and asked if that would be similar for median work.

City Engineer Westby was unsure if landscaping maintenance would qualify.

Councilmember Kuzma stated that he is tired of this being pushed back onto the City when the developer and homeowners' association want this landscaping.

Chairperson Riley stated that staff made the comment that the language is now being built in that addresses ongoing maintenance in clear terms. He suggested that perhaps the City contact the HOA for a specific property to ensure that they address the median as they are maintaining other

public space within the property. He used the referenced of Brookfield where the original HOA failed and there has been pushback on creating a new HOA.

Public Works Superintendent Riemer provided additional background information on Brookfield. He reviewed the three alternatives before the Committee to consider tonight. He provided additional cost information on the medians within Sweetbay Ridge that were repaired.

Chairperson Riley stated that there is a streetlight fee and asked if there could be a similar fee developed for median maintenance or whether that would not be worth the effort.

Public Works Superintendent Riemer stated that would need to be done with the approval of the development.

Chairperson Riley stated that he does not like the idea of the City taking over the maintenance and also does not like the idea of letting things go as they have been unmaintained. He noted that removal of medians has also been considered but there is a high cost to do so and the medians provide benefit.

Parks and Assistant Public Works Superintendent Riverblood replied that prudently maintained entrances to neighborhoods and medians do add value to aesthetics and increase property values, as well as have a calming effect on traffic. He believed that HOAs should continue to maintain those elements.

Councilmember Kuzma stated that perhaps a policy be developed that would require maintenance by the HOA and if that maintenance stops, the median would be torn out and the cost would be assessed.

Chairperson Riley suggested that staff continue to enforce this element as it has been and any functioning HOAs need to maintain their medians.

Ms. Musgrove stated that perhaps the City could propose to a nursery to take over the median which would provide that business with the opportunity for additional marketing.

Chairperson Riley agreed that could be an option which would allow a sign stating that care and plantings provided by the business.

Motion by Councilmember Kuzma, seconded by Chairperson Riley, to make no changes to the existing policy and continue to approach requests on a case by case basis.

Motion carried. Voting Yes: Chairperson Riley and Councilmember Kuzma. Voting No: None. Absent: Councilmember Johns.

## **6. COMMITTEE / STAFF INPUT**

### **6.01: Staff Updates on Improvement Projects and Items of Interest**

City Engineer Westby provided an update on the status of improvement projects and items of interest.

Chairperson Riley stated that he would like Ramsey to continue to be at the table with the Highway 47 and rail crossing discussions as there is a great impact to Ramsey.

City Engineer Westby provided information on the comparison of using borings on road projects and the ground penetrating radar.

Chairperson Riley agreed that the GPR is a great tool because it ensures that the City is getting what it paid for in terms of road construction.

City Engineer Westby noted that mobilization is a large portion of the cost and therefore the more miles you can include in one trip provides a cost savings rather than asking for multiple mobilization. He provided additional details on the GPR process.

It was the consensus of the Committee to continue to use GPR on the spring road projects and to add a requirement of new development to include the use of GPR and provide that data to the City prior to turning the roadway over to the City.

City Engineer Westby noted that the other cities involved in the Metropolitan Surface Water Supply Study all passed resolutions in support of the study and that information has been provided to the Metropolitan Council. He stated that additional details will be provided to the City with the length and cost of the study, confirming that the Metropolitan Council is funding 100 percent of that study. He provided an update on the Metropolitan Council's Water Efficient Potential Project, noting that a preliminary study was provided to the City. He stated that the preliminary finding identified that if the City can work with residents to reduce lawn irrigation, the two wells currently planned within the next ten years could be delayed. He noted that the numbers used were conservative and the cities involved provided updated data, advising that a final report will be available in February.

#### **6.02: Review Future Topics Calendar**

Chairperson Riley stated that he had asked to discuss the water aquifer and geology but believed that to be a better discussion for the full City Council rather than the Committee.

City Engineer Westby noted that has been added to the City Council worksession calendar in February.

### **7. ADJOURNMENT**

Motion by Councilmember Kuzma, seconded by Chairperson Riley, to adjourn the Public Works Committee meeting.

Motion carried.

The regular meeting of the Public Works Committee adjourned at 7:05 p.m.

Respectfully submitted,

---

Grant Riemer  
Public Works Superintendent

Drafted by Amanda Staple  
*TimeSaver Off Site Secretarial, Inc.*

**Public Works Committee**

**5. 1.**

**Meeting Date:** 12/18/2018

**By:** Bruce Westby, Engineering/Public Works

**Title:**

Consider Recommendation to City Council to Accept Petition Opposing Improvement Project #19-02, Brookview Estates Street Reconstructions

**Purpose/Background:**

**Purpose:**

The purpose of this case is to consider providing a recommendation to City Council to accept a petition opposing Improvement Project #19-02, Brookview Estates Street Reconstructions.

**Background:**

City Improvement Project No. 19-02 proposes to reconstruct streets within the Brookview Estates neighborhood including 173rd Avenue and Germanium Street. The streets total approximately 2,662 linear feet (0.50 miles) in length.

A map showing the location of the project is attached. A map showing the scope of the proposed improvements is included in the attached Feasibility Report as *Figure 1 of Appendix A*.

The engineer's opinion of probable costs for completing the proposed improvements as summarized in *Appendix B* of the Feasibility Report is \$502,555.46. Estimated costs include 5-percent contingency costs plus 23-percent indirect costs for administrative, engineering, finance and legal costs.

Per the Feasibility Report, twenty-one (21) properties are considered to benefit from the improvements and Staff recommended applying 25-percent of eligible project costs equally across the 21 assessable properties using the "per lot" assessment method. Eligible project costs include everything except subgrade corrections and guardrail modification costs. This resulted in a proposed preliminary assessment rate of \$4,418.30 per assessable parcel.

Following the Public Hearing on November 13th, the property owner at 17230 Germanium Street requested a petition template to use in gathering signatures in opposition to this Council initiated improvement project as provided by Section 8.4.5 of the City Charter. A copy of Chapter 8 of the City Charter is attached.

On November 15th, Staff provided a copy of the petition template to the property owner with instructions to modify the top of the petition to define the project and to note what the petition specifically opposes. This property owner did attend the neighborhood information meeting held on November 8, 2018 where Staff explained the proposed improvements and assessments in detail and gathered public input on the project.

On December 3rd, the property owner delivered a petition with 15 signatures on it to City Staff but Staff rejected it noting that the top of the petition had no clarifying language on it leading to concerns that the petitioners might not have understood what they were signing. Based on comments Staff received from several property owners while the petition was being circulated, Staff had concerns that this might indeed be the case. City Staff then contacted the City Attorney to seek further direction on petition language and process requirements.

On December 4th, Staff provided clarifying comments to the property owner circulating the petition based on the City Attorney's comments.

On December 10th, the property owner submitted a revised petition to City Staff. This petition had a page attached

to it with clarifying language noting that the property owners objected to the cost of the project. See attached. Staff has since verified that all property owners who signed the petition are indeed benefiting property owners per the preliminary assessment roll contained within the Feasibility Report.

Staff is currently working with the City Attorney to verify that the petition is valid as presented. Staff is also working to verify that the property owners who signed the petition fully understood what they were signing, and that by signing the petition they could be killing the project for a year or more.

Staff will provide updated information during the presentation at the meeting.

**Timeframe:**

Staff estimates 20 minutes will be required to present and discuss this case.

**Observations/Alternatives:**

**Alternatives:**

Alternative #1 – Motion recommending that the City Council accept the petition as presented and to direct Staff to stop all work on City Improvement Project #19-02, Brookview Estates Street Reconstructions, for a period of at least one-year.

Alternative #2 – Motion of other.

**Funding Source:**

N/A

**Recommendation:**

Staff’s recommendation will depend on the City Attorney’s responses.

Staff will recommend Alternative #1 if the City Attorney confirms that the petition as presented is valid, and if Staff believes the property owners who signed the petition understood what they were signing.

Staff will recommend Alternative #2 if the City Attorney confirms that the petition as presented is not valid, or if Staff believes the property owners who signed the petition did not understand what they were signing.

**Action:**

To be determined based on further findings.

---

**Attachments**

[Project Location Map](#)

[City Charter Chap 8](#)

[Feas Report 1902](#)

[Petition Recvd 121018](#)

---

**Form Review**

**Inbox**

Grant Riemer

Kurt Ulrich

Form Started By: Bruce Westby

Final Approval Date: 12/13/2018

**Reviewed By**

Grant Riemer

Kurt Ulrich

**Date**

12/13/2018 03:08 PM

12/13/2018 03:53 PM

Started On: 12/11/2018 10:34 AM

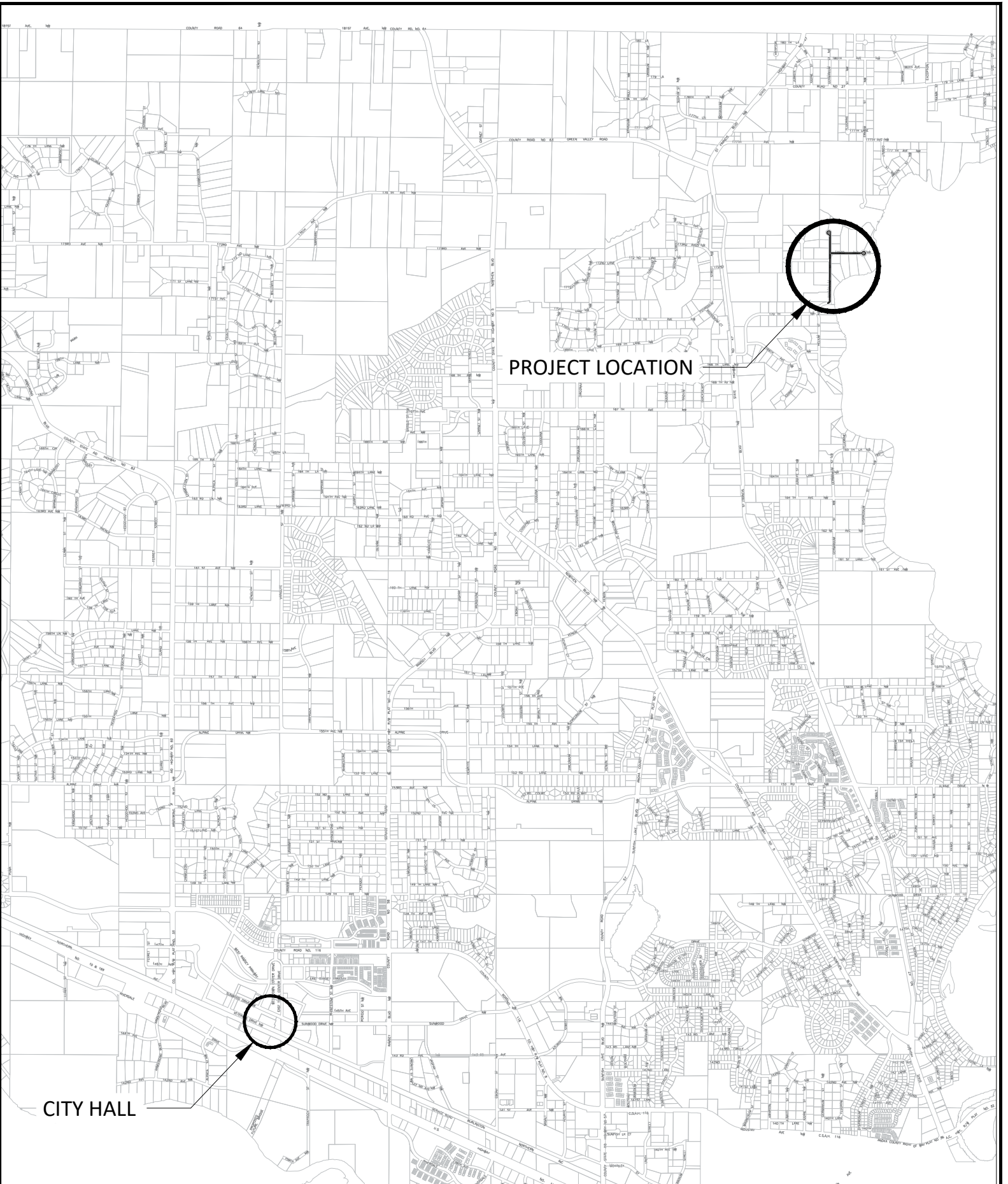

PROJECT LOCATION

CITY HALL

# BROOKVIEW ESTATES PROJECT LOCATION

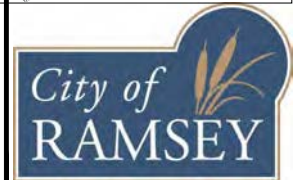
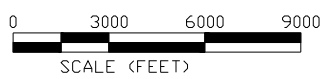

## CHAPTER 8. - PUBLIC IMPROVEMENTS AND SPECIAL ASSESSMENTS

### Sec. 8.1. - Power to make improvements and levy assessments.

The city may make any type of local improvement not forbidden by law and levy special assessments to pay all or part of the cost of such local improvements. The total of the assessments for any local improvement may not exceed the cost of the local improvement, plus all costs and expenses connected therewith, including interest. No assessment shall exceed the benefit to the property assessed as measured by the increase in the market value of the property assessed as a result of the local improvement.

(Ord. of 1-25-1993)

### Sec. 8.2. - Application of Charter.

All local improvement projects shall be carried out exclusively under the provisions of this Charter. The term "local improvement" as used in this section shall mean a public improvement financed partly or wholly from special assessments.

(Ord. of 1-25-1993)

### Sec. 8.3. - Assessments for services.

The council may provide by ordinance that the cost of the city services to streets, sidewalks, or other public or private property may be assessed against property benefited and may be collected in the same manner as special assessments.

(Ord. of 1-25-1993)

### Sec. 8.4. - Local improvement procedure.

When the city undertakes any local improvement to which the state local improvement code, Minn. Stats. chapter 429 applies, it shall comply with the provisions of that law, except as modified below. The council may by ordinance prescribe the procedure to be followed in making any other local improvement and levying assessments therefor.

8.4.1 *Sixty-day waiting period.* A period of 60 days shall elapse after the conclusion of the public hearing required by law to precede the ordering of the construction of a local improvement project (the "public hearing") before the actual ordering of the local improvement by the council and the council entering into a contract for the local improvement construction.

8.4.2 *Percentage of owners required.* When the local improvement has been petitioned for by the owners of not less than 50 percent in frontage of the real property abutting on streets named in the petition as the location of the local improvement the resolution ordering the local improvement by the council may be approved by vote of a majority of all members of the council. When there has been no such petition, the resolution may be adopted only by vote of four-fifths of all members of the council.

8.4.3 *Petition against the local improvement.* A proposed local improvement may be initiated by petition of the owners of real property abutting on the streets named in the petition. If, within 30 days of the conclusion of the public hearing, a petition against such local improvement is filed with the city administrator which petition is signed by a percentage of the owners of real property abutting on the streets named in the initiating petition as the location of the improvement which

percentage is greater than the percentage of owners of real property who signed the initiating petition, the council shall not make such local improvement at the expense of the abutting property owners. For purposes of the foregoing sentence, "owners of real property" shall not include owners of properties zoned for commercial or industrial uses or owners of properties zoned residential greater than ten acres in size based on zoning classifications in effect at the date of such petition, or owners of non-homestead real property greater than one acre in size.

8.4.4 *Counter petition in favor of the improvement.* If within 30 days of the filing with the city administrator of a petition against the local improvement as described in section 8.4.3 above, there is filed with the city administrator a petition in favor of the local improvement, signed by owners of real property abutting on the streets named in the initiating petition as the location of the improvement, in a percentage greater than the percent of owners of real property who signed the petition against the local improvement, then in such event the council may disregard the petition against the local improvement and proceed with the local improvement.

8.4.5 *Petition against council initiated improvement.* If the local improvement was initiated by council resolution without an initiating petition and, within 60 days of the conclusion of the public hearing, a petition is filed with the city administrator against such local improvement and which petition is signed by 60 percent or more of the owners of real property proposed to be assessed for and benefited by the local improvement, the council shall not make such local improvement at the expense of the benefited property owners. For purposes of the foregoing sentence, "owners of real property" shall not include owners of properties zoned for commercial or industrial uses or owners of properties zoned residential greater than ten acres in size based on zoning classifications in effect at the date of such petition, or owners of non-homestead real property greater than one acre in size.

8.4.6 *Withdrawal of name from petition.* Any person whose name appears on a petition to the council in favor of a local improvement, or on a petition to the council filed against a local improvement, may withdraw his/her name by a statement in writing filed with the city administrator before such petition is presented to the council or in person at a city council meeting before the city council accepts said petition.

8.4.7 *Filing of petition with city council.* All completed petitions filed with the city administrator as described herein shall be presented to the council by the city administrator at the council's next regularly scheduled meeting.

8.4.8 *One year before any further action.* When a proposed local improvement is disallowed pursuant to the petition process described in the foregoing sections, the council shall not vote on the same improvement within a period of one year after the public hearing on said improvement.

(Ord. of 1-25-1993; Ord. No. 06-22, § 2, 7-5-2006; Ord. No. 12-08, § 2, 6-26-2012; Ord. No. 14-07, § 2, 8-11-2014)

#### Sec. 8.5. - Computation of time.

Where the performance or doing of any act or matter is required by this Charter, and the period of time is prescribed and fixed by this Charter, the time shall be computed so as to exclude the first and include the last day of the prescribed or fixed period of time. When the last day of the period falls on a Saturday, Sunday, or a legal holiday, that day shall be omitted from the computation.

(Ord. of 1-25-1993)

#### Sec. 8.6. - Sewer and water projects.

This section applies to any local improvement project completed after January 1, 1996, which includes extending urban services (sewer and/or water) to an existing home or neighborhood.

- 8.6.1 *Connection policy.* The city may not compel any property owner with a functional private sewer and water system to connect to city sewer and/or water.
- 8.6.2 *Assessment policy.* The city may not levy an assessment for any component of any project which includes sewer and/or water improvements against a property whose owner elects to remain on a functional private sewer and/or water system.
- 8.6.3 *Request for urban services.* Property owners who remain on private sewer and water systems after urban services become available may request connection to urban services at any time. Upon connection to urban services an assessment may be levied provided it is consistent with the original assessment.

(Ref. of 5-20-1996; Ord. of 1-24-2001)

# FEASIBILITY REPORT

---

## BROOKVIEW ESTATES STREET RECONSTRUCTIONS

**CITY IMPROVEMENT PROJECT NO. 19-02**

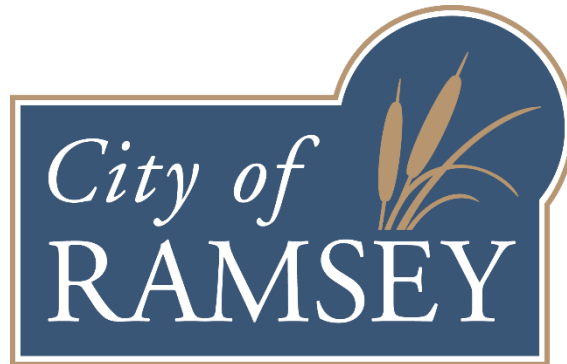

**October 18, 2018**

**Prepared By:**

**City of Ramsey  
Engineering Department  
7550 Sunwood Drive NW  
Ramsey, MN 55303  
763-433-9839  
763-433-9848 (Fax)**

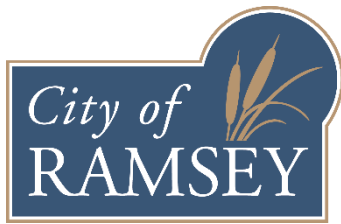

October 18, 2018

Honorable Mayor and City Council  
City of Ramsey  
7550 Sunwood Drive NW  
Ramsey, MN 55303

Re: Feasibility Report - City of Ramsey Improvement Project #19-02  
Brookview Estates Street Reconstructions

Dear Mayor and City Council Members:

Transmitted herewith is a Feasibility Report for the proposed Brookview Estates Street Reconstructions project including; 173<sup>rd</sup> Avenue from Germanium Street to its termini cul-de-sac, and Germanium Street from 170<sup>th</sup> Lane to its termini cul-de-sac. The report examines the feasibility of reconstructing the bituminous street section and completing other appurtenant improvements.

This Feasibility Report examines the scope of the proposed improvements, explores estimated costs and available funding sources, defines a preliminary project schedule, and determines the necessity, feasibility and general cost-effectiveness of the proposed improvements, including any alternate designs, as well as whether the improvements would best be completed separately or in conjunction with another project.

I would be happy to discuss this report with you at your convenience. Please feel free to contact me at 763-433-9825 or [bwestby@cityoframsey.com](mailto:bwestby@cityoframsey.com) with any questions.

Sincerely,

**City of Ramsey**

Bruce Westby, PE  
City Engineer

Enclosure

C: Kurt Ulrich, City Administrator  
Leonard Linton, Civil Engineer IV

## CERTIFICATION

---

I hereby certify that this plan, specification or report was prepared by me or under my direct supervision and that I am a duly Licensed Professional Engineer under the laws of the State of Minnesota.



---

Bruce Westby, PE

Date: October 18, 2018

License No. 40116

I hereby certify that this plan, specification or report was reviewed for Quality Control and Quality Assurance purposes and that I am a duly Licensed Professional Engineer under the laws of the State of Minnesota.



---

Leonard Linton, PE

Date: October 18, 2018

License No. 21112

**TITLE SHEET  
LETTER OF TRANSMITTAL  
CERTIFICATION SHEET  
TABLE OF CONTENTS**

Table of Contents

**1. EXECUTIVE SUMMARY .....4**

**2. INTRODUCTION ..... 6**

2.1 Authorization..... 6

2.2 Program Overview ..... 6

2.3 Scope ..... 6

3.1 Existing Pavement, Soil, and Traffic Conditions ..... 7

3.2 Watermain ..... 8

3.3 Sanitary Sewer ..... 8

3.4 Storm Sewer / Drainage ..... 8

3.5 Streets..... 8

3.5.1 Existing Typical Sections ..... 8

3.5.2 Maintenance History..... 8

3.6 Land Use ..... 8

**4. PROPOSED IMPROVEMENTS ..... 9**

4.1 Street and Stormwater Improvements ..... 9

4.1.1 Street Improvements ..... 9

4.1.2 Storm Sewer Improvements ..... 9

4.1.3 Geotechnical Considerations ..... 9

4.1.4 Other Considerations ..... 10

4.2 Stormwater Treatment..... 11

4.3 Water Main Improvements ..... 11

4.4 Sanitary Sewer Improvements ..... 11

4.5 Construction Method..... 11

4.6 Private Utilities..... 11

4.7 Permits ..... 11

4.8 Right-of-Ways / Easements..... 11

**5. FINANCING ..... 13**

5.1 Opinion of Cost..... 13

5.2 Funding ..... 13

5.2.1 Assessments..... 13

5.2.2 City Contribution..... 14

**6. PROJECT SCHEDULE..... 15**

**7. CONCLUSIONS AND RECOMMENDATIONS..... 16**

**Appendix A**

Figure 1 – Project Scope  
Figure 2 – Typical Section  
Project Site Pictures

**Appendix B**

Opinion of Probable Costs  
Preliminary Assessment Map  
Preliminary Assessment Roll

**Appendix C**

Street Segment Summary  
Ground Penetrating Radar Summary  
Geotechnical Report (NTI)

## 1. EXECUTIVE SUMMARY

City Improvement Project No. 19-02 proposes to reconstruct streets within the Brookview Estates neighborhood including 173<sup>rd</sup> Avenue and Germanium Street. The streets total approximately 2,662 linear feet (0.50 miles) in length. A map showing the location and scope of the proposed improvements is included as *Figure 1* in *Appendix A*.

The streets were constructed in 1979 as rural sections with bituminous pavement to a width of 24 feet, and are generally centered within a 66-foot wide right-of-way.

The storm sewer system generally consists of ditches along both sides of the road within the right-of-way and drainage and utility easements. Storm runoff collects in the ditch along Germanium Street and is carried north to the Trott Brook through an outlet pipe located in the north cul-de-sac. Storm runoff collects in the ditch along 173<sup>rd</sup> Avenue and goes across land into the Rum River to the east.

The existing bituminous pavement section ranges from 2.0 to 6.0 inches thick, with a median thickness of 3.6-inches, and the aggregate base ranges from 0.8 to 5.0 inches thick, with a median thickness of 2.7-inches. This was determined from Ground Penetrating Radar (GPR) analysis performed by Braun Intertec in 2017, as well as from field observations and record plan documents. Copies of Braun Intertec's GPR results are attached in *Appendix C*. The pavement section was built on primarily poorly graded sands with silts subgrade material which is generally considered usable for pavement support with the proper preparation.

City staff evaluates and rates the condition of pavement sections on all City streets on an annual basis using the Pavement Surface Evaluation and Rating (PASER) system. In the summer of 2018, the pavement section of the above referenced street segments were rated with a PASER rating of 3 which indicates these streets require complete reconstruction. City staff patch the streets at least once per year, particularly before winter so the streets can be plowed without further damaging the pavement in the process. Pictures of the streets are located in *Appendix A*.

Proposed improvement include reconstructing the existing bituminous pavement section using the Full Depth Reclamation (FDR) process. This process involves reclaiming the entire existing bituminous pavement section, along with the existing aggregate base material. A portion of this reclaimed (ground and mixed) material would then be spread and compacted on top of the reshaped and compacted subgrade. Then, 3.5 inches of bituminous pavement would be placed, generally meeting the City of Ramsey's standard pavement design for residential streets.

Existing ditches will likely require re-grading and other drainage construction is likely, however, driveway culverts are generally not anticipated to be affected by this project. Additional storm sewer is anticipated to be added to improve storm runoff water quality prior to flowing into Trott Brook. Drainage easements may be needed in one or more locations.

The engineer's opinion of probable costs for completing the proposed improvements outlined in this report is \$502,555.46. Estimated costs include 5-percent contingency costs plus 23-percent

indirect costs for administrative, engineering, finance and legal costs. A summary of the engineer's opinion of probably costs is included in *Appendix B*.

A total of 21 assessable parcels have been identified. Staff recommends applying 25-percent of the eligible project costs equally across the 21 assessable properties using the "per lot" assessment method. Eligible project cost include everything except subgrade corrections and guardrail modification costs. This results in a proposed preliminary assessment rate of \$4,418.30 per assessable parcel.

Staff recommends ordering a special benefit consultation report for this project to verify the proposed assessment amount will not exceed the benefit to the properties. If the report concludes the benefit to the properties is less than the proposed preliminary assessment rate, Staff will then propose to lower the assessment rate accordingly during the Assessment Hearing, which is scheduled for October 8, 2019. If the report verifies the assessment rate as proposed is justified, Staff will propose to adopt the final assessment roll using the rate as preliminarily proposed.

Seven (7) soil borings were completed by Northern Technologies (NTI) to assist with the preparation of this report. Pavement design recommendations were offered by NTI, and Staff considered and incorporated NTI's recommendations to varying degrees while preparing this report. Ground Penetrating Radar (GPR) was conducted on street segments within the project. The GPR identifies existing bituminous pavement and aggregate base thicknesses, and is used to help Staff determine the appropriate treatment. Copies of Braun Intertec's GPR results and NTI's Geotechnical Exploration Report are attached in *Appendix C*.

This improvement project, which is listed in the City's current 10-year Capital Improvement Plan, is proposed to be funded using a combination of special assessments to benefiting properties, street reconstruction bond proceeds, and storm sewer funds.

Staff has not yet discussed the proposed improvements with local property owners. However, Staff has scheduled a neighborhood information meeting for November 8, 2018 for the purpose of explaining the proposed improvements and assessments in more detail, and to gather public input on the project, including any information which should be explored in more detail during development of plans and specifications. Staff will incorporate comments and present this information to Council during the Public Hearing on November 13, 2018.

This project would best be constructed as a stand-alone project and is necessary, feasible, and cost-effective from an engineering standpoint, and can be constructed as proposed herein.

## **2. INTRODUCTION**

### **2.1 Authorization**

The preparation of this report was authorized by the Ramsey City Council on August 28, 2018. This project has been designated as City Improvement Project No. 19-02.

### **2.2 Program Overview**

In support of the City's long-term Street Maintenance Program, the existing bituminous pavement section will be reconstructed, and existing ditches will be re-graded to enhance drainage. Other appurtenant work will be completed as outlined in this report.

The City's pavement evaluation process involves a visual evaluation of each street's pavement surface based on the type, extent and severity of each pavement distress observed. Numerous types of pavement distresses may exist within a pavement section including, but not limited to, alligator cracking, block cracking, longitudinal cracking, transverse cracking, rutting, raveling, shoving, potholes and patches. This field data is then used to rate the pavement condition.

The City uses the Pavement Surface Evaluation and Rating (PASER) system to rate pavement condition. A PASER rating is a numerical index between 1 and 10 indicating the condition of a pavement based on the various pavement distresses recorded during visual observations. A PASER rating of 10 represents brand new pavement, while a PASER rating of 1 represents a pavement section that has fallen into complete disrepair requiring full reconstruction.

In the summer of 2018, City Staff evaluated and rated the condition of the pavement along the Brookview Estates street segments. A PASER rating of 3 was assigned to 173<sup>rd</sup> Avenue and Germanium Street.

### **2.3 Scope**

City of Ramsey Improvement project 19-02 proposes to reconstruct the existing bituminous pavement, re-shape the ditches to enhance drainage, and to complete other appurtenant work on 173<sup>rd</sup> Avenue from Germanium Street to its termini cul-de-sac, and Germanium Street from 170<sup>th</sup> Lane to its termini cul-de-sac which totals approximately 2,662 linear feet (0.50 miles) in length.

The existing bituminous pavement section is proposed to be reconstructed using the FDR process. This involves reclaiming the entire bituminous pavement section along with a portion of the existing aggregate base, hauling and disposing of excess reclaim material off-site, spreading and compacting the reclaimed material on top of the reshaped and compacted subgrade, then placing 3.5-inches of new bituminous pavement on top. The resulting pavement design will generally meet current City design standards for residential pavement sections.

A map showing the location and scope of the proposed improvements is included as *Figure 1* in *Appendix A*.

### 3. EXISTING CONDITIONS

#### 3.1 Existing Pavement, Soil, and Traffic Conditions

All streets proposed to be improved were constructed in 1979 with 1.5-inches of bituminous pavement, 3.0-inches of aggregate base, and ditches. The streets are generally centered within a 66-foot wide right-of-way.

Pavement maintenance treatments applied to the street segments included overlay in 1993, and crack seal and seal coat improvements in 2001. Spot patching has been performed on an as-needed basis, and has been a yearly treatment recently. In 2018, Staff assigned a PASER rating of 3 on both street segments.

In September of 2018, City Staff recorded a traffic volume of 72 average annual daily traffic (AADT) on 173<sup>rd</sup> Avenue east of Germanium Street, and 278 AADT on Germanium Street north of 170<sup>th</sup> Lane. The speed limit is 30 mph for these street segments.

Northern Technologies, LLC (NTI) was employed to complete a Geotechnical Exploration and Engineering Review for this project, which included seven (7) soil borings spaced evenly along 173<sup>rd</sup> Avenue and Germanium Street. The locations of the borings are shown in the Soil Boring Location Map in Appendix C of NTI's report, attached in *Appendix C*.

The soil borings provide information on existing bituminous pavement and aggregate base course thicknesses, subgrade soil conditions, existing ground water elevations, and potential issues, which may be encountered during construction. The borings general terminated at a nominal depth of 10 feet below the existing ground surface, boring number 4 terminated at 20.5 feet as it was following a layer of clay. There was groundwater observed in 4 of 7 borings, with elevations varying from approximately 872.5 to 877, 6.5 to 9.0 feet below the existing surface. Based on the work proposed groundwater is not anticipated to be a significant issue for work completed with this proposed project. There is the small potential for groundwater impacts if storm sewer is required, and is placed at a depth greater than 6-feet below the existing ground.

The soil borings generally indicate the existing bituminous pavement thickness ranges between 2 ¼ to 5 inches, and aggregate base thickness is 5 to 6 inches. The subgrade generally consists of poorly graded sand with silt, silty sand, and poorly graded sand. Below this 4 of the 7 borings had layers of lean clay with sand, clayey sand, and / or lean to fat clay. The depths of the layers varied among the borings, and the pockets with clay seemed to be spread out along the project.

Braun Intertec was employed to complete a ground penetrating radar (GPR) analysis for the project area, which included driving the GPR equipped vehicle throughout all street segments within the project area. A summary table and charts of the GPR Analysis are attached in *Appendix C*. The GPR data determined a median bituminous pavement thickness of 3.6-inches, and a median aggregate base thickness of 2.7-inches. The median street pavement and base section thickness was 6.2-inches, with a minimum section of 3.7-inches located on Germanium Street, 310 feet north of 173<sup>rd</sup> Avenue. GPR data was not able to be obtained for 173<sup>rd</sup> Avenue.

## **3.2 Watermain**

Watermain does not exist on site.

## **3.3 Sanitary Sewer**

Sanitary sewer does not exist on site.

## **3.4 Storm Sewer / Drainage**

The storm sewer system consists of ditches along both sides of the road within the right-of-way and drainage and utility easements, which direct stormwater runoff to the ditch along Germanium Street and north to the Trott Brook through an outlet pipe located in the north cul-de-sac. Stormwater runoff is also directed to the ditch along 173<sup>rd</sup> Avenue and goes across land into the Rum River to the east.

## **3.5 Streets**

### ***3.5.1 Existing Typical Sections***

The pavement width of 173<sup>rd</sup> Avenue and Germanium Street is 24-feet. The cul-de-sacs on 173<sup>rd</sup> Avenue and Germanium Street are 95-feet in diameter. The streets are centered within a 66-foot wide City-owned right-of-way, with a 160-foot wide right-of-way around the cul-de-sac on 173<sup>rd</sup> Avenue, and a 140-foot wide right-of-way around the cul-de-sac on Germanium Street.

### ***3.5.2 Maintenance History***

Brookview Estates was originally constructed in 1979. 173<sup>rd</sup> Avenue and Germanium Street received an overlay in 1993, and crack seal and seal coat improvements in 2001.

## **3.6 Land Use**

The parcels within the construction area are zoned rural developing.

## 4. PROPOSED IMPROVEMENTS

### 4.1 Street and Stormwater Improvements

#### 4.1.1 Street Improvements

The streets in Brookview Estates are proposed to be reconstructed by matching existing widths and elevations with bituminous pavement and ditch sections to carry storm water runoff to Ford Brook and the Rum River.

The proposed surface improvements are shown on *Figure 1* in *Appendix A*.

#### *Street Design:*

173<sup>rd</sup> Avenue and Germanium Street are currently rural residential streets with ditch sections, 24-foot wide to the edge of pavement. The cul-de-sacs on 173<sup>rd</sup> Avenue and Germanium Street are 95-foot in diameter. Existing and proposed traffic counts are consistent with typical residential streets.

All street segments are proposed to be reconstructed at their current width. A typical section for the proposed pavement reconstruction improvements is shown in *Figure 2* in *Appendix A*.

City Staff is proposing a pavement section design of 1.5-inches bituminous wear course, 2-inches bituminous base course, and 4-inches of aggregate base composed of full-depth reclamation material. This pavement section would be constructed over the existing subgrade after it is reshaped and compacted.

#### 4.1.2 Storm Sewer Improvements

The existing ditch sections are in good condition. Re-shaping the ditches may be required due to construction, but ditches will be restored to existing grades. The existing driveway culverts are not anticipated to be replaced. No stormwater treatment improvements are required for this projects since the street is proposed to be reconstructed at its current width, however, Staff is proposing to add a treatment structure to improve storm runoff water going into Trott Brook.

#### 4.1.3 Geotechnical Considerations

Northern Technologies LLC (NTI) completed a Geotechnical Exploration and Engineering Review including seven (7) soil borings, generally evenly spaced along 173<sup>rd</sup> Avenue and Germanium Street. The locations of the borings are shown in the Boring Location Map in Appendix C of NTI's report, attached in *Appendix C*. NTI recommends prior to installing the aggregate base, the existing subgrade should be scarified and re-compacted to a depth of at least 12 inches. A proof roll test should then be performed to determine soft or unstable subgrade areas. If rutting or localized unstable subgrade areas are observed, those areas

should be subcut, moisture-conditioned, and re-compacted or removed to a stable depth. Based upon the encountered subgrade conditions, estimated R-value of 30 for the existing subgrade soils, the assumed AADT volumes of 600, and the City of Ramsey's typical pavement section for the respective project area NTI recommends a pavement section of 4-inches of aggregate base class 5, and 4-inches of bituminous pavement. City Staff is in close agreement and proposes completing a full-depth reclamation of the existing pavement by placing 4-inches of aggregate base class 5 or reclaim material, and 3.5-inches of new bituminous pavement. The clay layers are generally deep enough to not have a significant impact on the roadway, however Staff will be aware of the potential for pockets of subgrade which will require additional conditioning or possible replacement.

The proposed improvements should have a service life of approximately 60-years, assuming maintenance such as overlays, crack sealing and seal coating is routinely performed.

#### ***4.1.4 Other Considerations***

##### ***Driveways:***

Existing driveway aprons may need to be reconstructed to varying degrees. The limits of construction will vary with each driveway apron based on the elevation of the street abutting the driveway and the driveway pavement type. During design, Staff will evaluate the construction limits for each driveway and will incorporate this into the plans, but as with all street reconstruction projects, the exact limits of construction will be determined in the field during construction. Right-of-entry forms will be obtained from private property owners where work is required outside City right-of-ways and easements.

##### ***Irrigation Systems:***

Developed properties along the project corridor may have private irrigation systems. Staff will notify property owners of pending construction as far in advance as practical to allow them time to move their irrigation systems out of harm's way before work begins.

##### ***Parking Restrictions:***

Parking is currently provided along both sides of the streets and is not currently restricted except for overnight parking per City code. During this project, parking will be restricted during allowable working hours.

##### ***Pavement Corings:***

Existing pavement thicknesses have been found to be inconsistent throughout the City. It is now standard practice to have City Staff on-site during pavement installation to insure the proper quantities are being placed. As further conformation, Staff is proposing to collect GPR data or to have pavement corings taken at the conclusion of all reconstruction projects. This is already a requirement on all State Aid projects, and will leave more data on the pavement section for future street maintenance projects.

## **4.2 Stormwater Treatment**

No stormwater retention and/or treatment improvements will be required as a result of this project, however, Staff is proposing stormwater treatment for storm runoff into Trott Brook.

## **4.3 Water Main Improvements**

No watermain improvements are proposed with this project.

## **4.4 Sanitary Sewer Improvements**

No sanitary sewer improvements are proposed with this project.

## **4.5 Construction Method**

The existing bituminous pavement section will be reconstructed using the FDR process outlined within this report.

## **4.6 Private Utilities**

Staff has not yet met with the telephone, gas, power and cable utilities regarding this project. During preparation of plans and specifications, Staff will meet with the private utility companies to discuss the proposed improvements as noted in the project schedule within this report. The alignment and footprint of the streets will be considered to minimize impacts to private utilities. No impacts to power poles or street lights are anticipated with this project.

Should any utility company indicate they wish to upgrade, replace and/or otherwise modify their services during this project, any such upgrades, replacements and/or modifications will be at the sole discretion and cost of the utility company.

## **4.7 Permits**

Permits that are anticipated to be required as part of the proposed improvements include:

- MPCA General Stormwater Permit (NPDES).....Grading and Storm Water

A stormwater permit from the Lower Rum River Watershed Management Organization will not be required with this project as street reconstruction projects are exempt.

## **4.8 Right-of-Ways / Easements**

The existing outfall to Trott Brook is currently located on 17331 Germanium Street outside of City-owned drainage and utility easements. Staff will work with the property owner to create additional drainage and utility easement over the existing pipe, move the outfall which would also

require additional easement, or find another solution. This will be dependent upon project design and discussion with the property owner.

A low area exist outside of City-owned drainage and utility easement on 17310 Germanium Street, possible options of filling in the low area, adding addition storm sewer, or acquiring drainage and utility easements will be discussed with the property owner and are also dependent upon project design.

City Staff will obtain required right of entries on a case by case basis.

## 5. FINANCING

### 5.1 Opinion of Cost

A detailed opinion of probable costs for the proposed improvements can be found in *Appendix B* of this report. The opinion of probable costs incorporates anticipated 2019 construction costs for the proposed improvements with 5-percent contingency costs, plus 23-percent indirect costs for administrative, engineering, financing and legal costs.

City Staff prepared the Feasibility Report in-house as part of Staff's normal duties.

NTI prepared the Geotechnical Exploration and Engineering Review, included in *Appendix C*, at a cost of \$3,250.00.

### 5.2 Funding

#### 5.2.1 Assessments

A portion of the project costs is proposed to be recovered through special assessments levied against the 21 identified benefiting properties; 9 along 173<sup>rd</sup> Avenue, and 12 along Germanium Street. Assessments are proposed to be collected for eligible improvements benefiting residential properties with direct access to the improved segments of Brookview Estates as described below. A preliminary assessment summary is included below in *Table 1*.

#### Residential Assessments:

Special assessments are proposed to be levied against residential properties having direct access to improved streets. To be consistent with previous applications of the Special Assessments Policy, each residential property is proposed to be assessed using the "per lot" method.

Each residential property is preliminarily proposed to be assessed at the rate of \$4,418.30 per lot. Since State Statute and the City Charter do not allow for assessments to exceed the benefit to the property, Staff requests Council authorization to order a benefit appraisal consultation for this project in accordance with the City's Special Assessment Policy.

The Preliminary Assessment Map and Roll are included in *Appendix B*.

**TABLE 1**  
**Proposed Preliminary Assessments – 173<sup>rd</sup> Avenue & Germanium Street**

<b>STREET SEGMENT</b>	<b>ASSESSMENT PER LOT</b>	<b>No. OF LOTS</b>	<b>TOTAL ASSESSMENTS</b>
173 <sup>rd</sup> Avenue Residential Assessment	\$4,418.30	9	\$39,764.70
Germanium Street Residential Assessment	\$4,418.30	12	\$53,019.60
<b>TOTAL PROJECT ASSESSMENTS</b>			<b>\$92,784.30</b>

### 5.2.2 City Contribution

The City contribution to the project would include all funding in excess of the amount collected through special assessments to benefiting properties. No funds have been budgeted for this project. The City's share of eligible project costs related to surface (street) improvements is proposed to come from the previously encumbered 5-year Street Reconstruction and Overlay Program bonds. Stormwater Utility Funds are proposed to pay for all storm sewer improvements.

*Table 2* illustrates the proposed project funding based on the design proposed within this report. This funding program assumes construction will occur in 2019.

**TABLE 2  
Proposed Project Funding**

	<b>ASSESSMENTS</b>	<b>CITY FUNDS</b>	<b>TOTAL</b>
<b>Surface</b>	\$ 80,112.90	\$ 371,754.41	\$ 451,867.31
<b>Storm Sewer</b>	\$ 12,671.40	\$ 38,016.75	\$ 50,688.15
<b>TOTAL</b>	\$ 92,784.30	\$ 409,771.16	\$ 502,555.46

<b>Total Project Cost</b>		<b>\$ 502,555.46</b>
Less Special Assessments	-	\$ 92,784.30
<b>Subtotal</b>	<b>=</b>	<b>\$ 409,771.16</b>
Less City Bonding Funds	-	\$ 371,754.41
<b>Subtotal</b>	<b>=</b>	<b>\$ 38,016.75</b>
Less Stormwater Utility Funds	-	\$ 38,016.75
<b>TOTAL Remaining Cost</b>	<b>=</b>	<b>\$ 0</b>

**6. PROJECT SCHEDULE**

The proposed project schedule is as follows:

Council Orders Feasibility Report .....	August 28, 2018
Council Accepts Feasibility Report / Orders Public Hearing .....	October 23, 2018
Staff Conducts Neighborhood Information Meeting .....	November 8, 2018
Staff Publishes Notices of Public Hearing .....	October 26 & November 2, 2018
Council Conducts Public Hearing / Authorizes Plans and Specifications .....	November 13, 2018
Staff Conducts Private Utility Coordination Meeting .....	November, 2018
Council Approves Plans and Specifications / Authorizes Ad for Bids .....	January 22, 2019
Staff Receives Bids .....	February 20, 2019
Council Awards Contract .....	February 26, 2019
Contractor Begins Construction .....	May, 2019
Contractor Completes Construction .....	August 16, 2019
Council Orders Assessment Hearing .....	September 10, 2019
Council Conducts Assessment Hearing .....	October 8, 2019

## 7. CONCLUSIONS AND RECOMMENDATIONS

City of Ramsey Improvement Project No. 19-02 proposes to reconstruct the bituminous pavement section, and complete miscellaneous appurtenant work on the following street segments within the Brookview Estates residential subdivision:

1. 173<sup>rd</sup> Avenue (approx. 850 linear feet) – Germanium Street to east cul-de-sac.
2. Germanium Street (approx. 1810 feet) – 170<sup>th</sup> Lane to north cul-de-sac.

It is the recommendation of City Staff that City Project No. 19-02 is feasible, necessary, and cost-effective from an engineering standpoint, and this project would best be constructed as a stand-alone project as proposed herein.

The following Staff recommendations related to the proposed project are presented for Council consideration and concurrence:

1. Reconstruct the existing bituminous pavement using full-depth reclamation process, meeting the City's standard residential pavement section of 4-inches aggregate base class 5 (or reclaim), 2-inches new bituminous base course, and 1 ½- inches new bituminous wear course.
2. Staff recommends excluding private irrigation system work from this project. Instead, Staff will notify property owners of pending construction as far in advance as possible, and instruct them to relocate their irrigation system(s) away from the construction area during construction, then allow replacement in or near the original location after construction is complete.
3. Staff recommends holding a neighborhood information meeting on November 8, 2018 to inform property owners of the proposed improvements and to gather their input prior to competing plans and specifications and requesting Council approval to advertise for bids as outlined in the project schedule.
4. Order an assessment appraisal consultation to ensure special assessments do not exceed the benefit received as a result of the improvements.

The City Council is asked to act on the following items related to the proposed project:

1. Accept the preliminary residential special assessment rate of \$4,418.30 per lot.
2. Authorize an assessment appraisal consultation to ensure all special assessments are commensurate with benefit received from the proposed improvements.
3. Adopt Resolution #18-220 accepting this Feasibility Report and ordering the Public Hearing for November 13, 2018.

## APPENDIX A

**Figure 1 – Project Scope**  
**Figure 2 – Typical Section**  
**Project Site Pictures**

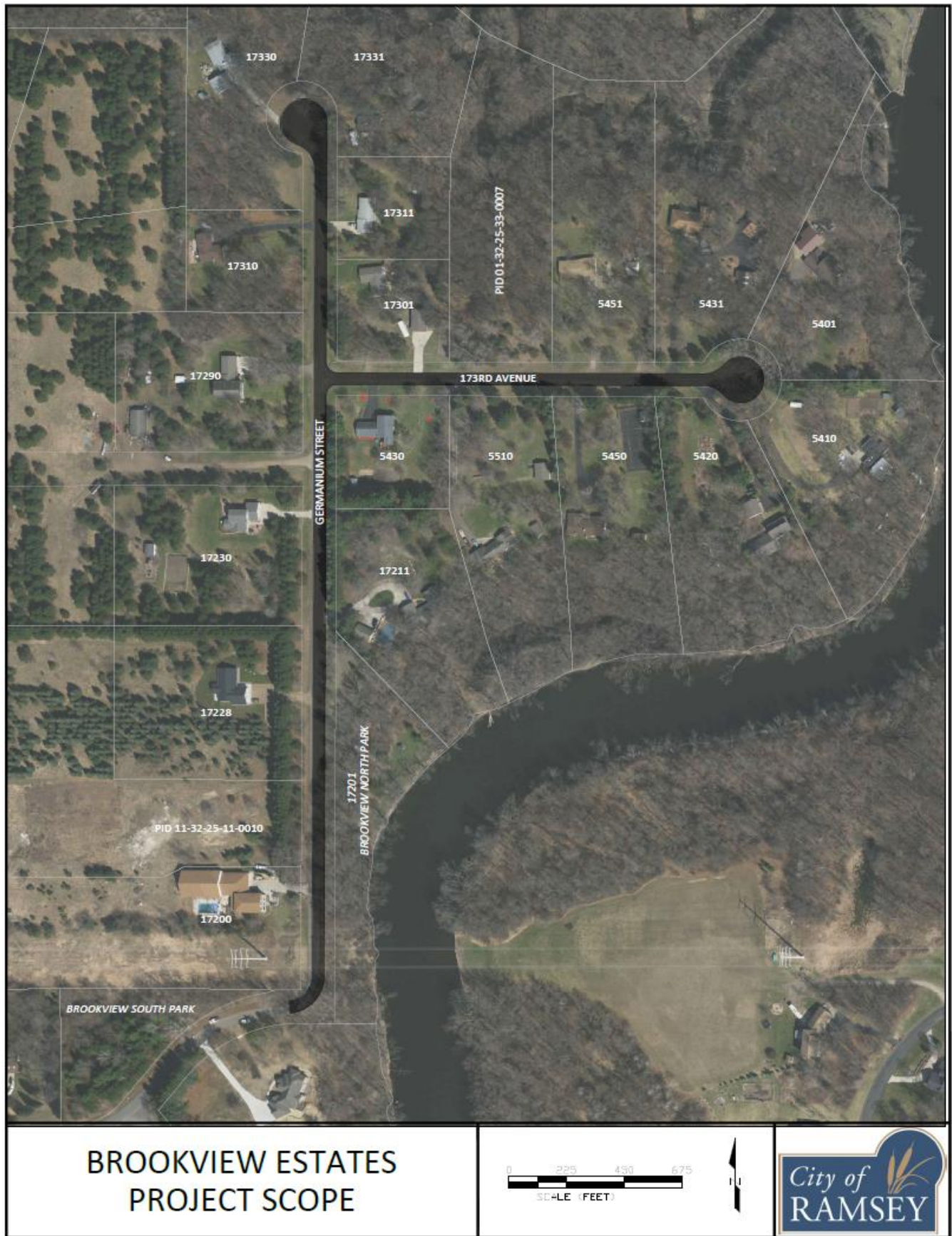

**FIGURE 1**

### 173rd Avenue & Germanium Street Typical Section

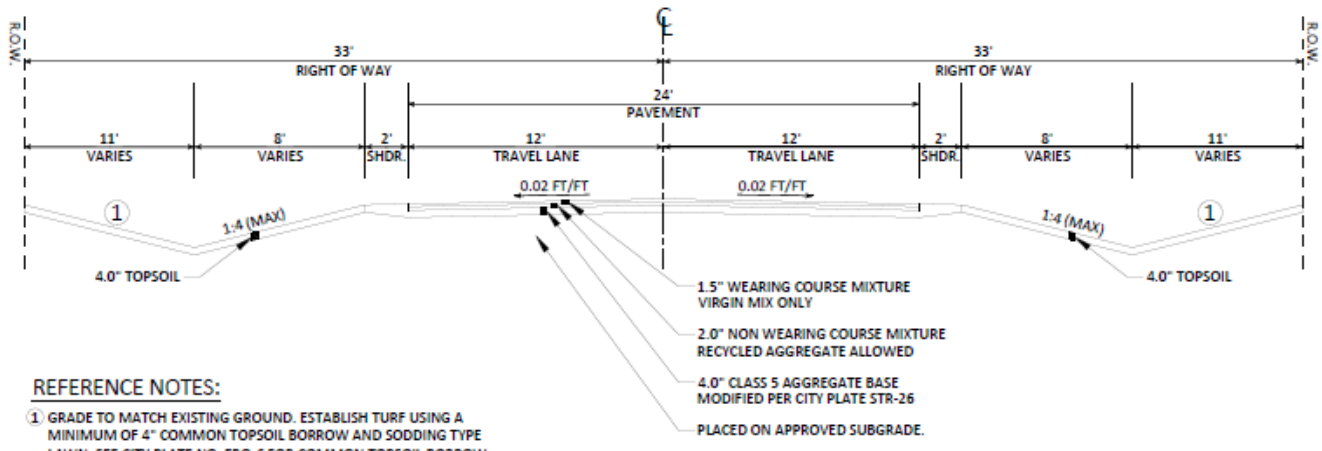

BROOKVIEW ESTATES  
TYPICAL SECTION

NOT TO SCALE

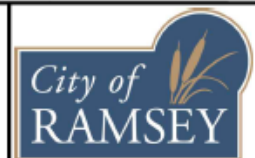

FIGURE 2

## **PROJECT SITE PICTURES**



**Picture 1: Germanium Street from 170<sup>th</sup> Lane**



**Picture 2: Germanium Street from 173<sup>rd</sup> Avenue**



**Picture 3: 173<sup>rd</sup> Avenue from Germanium Street**



**Picture 4: 173<sup>rd</sup> Avenue cul-de-sac, looking west**



**Picture 5: Germanium Street cul-de-sac, looking south**

**APPENDIX B**

**Opinion of Probable Costs (Preliminary Engineer's Estimate)  
Preliminary Assessment Map  
Preliminary Assessment Roll**



***Storm Sewer Construction***

<b>Item No.</b>	<b>Description</b>	<b>Unit</b>	<b>Estimated Quantity</b>	<b>Unit Cost</b>	<b>Cost Extension</b>
1	Geotextile Fabric Type V	SY	21	\$ 3.50	\$ 73.50
2	15" RC Pipe Apron	EA	4	\$ 600.00	\$ 2,400.00
3	Trash Guard for 15" RC Pipe Apron	EA	4	\$ 275.00	\$ 1,100.00
4	15" RC Pipe Sewer, Design 3006 Class III	LF	628	\$ 33.00	\$ 20,724.00
5	Construct Drainage Structure Design 48-4020	EA	3	\$ 2,500.00	\$ 7,500.00
6	Construct Drainage Structure Design Special 48-4020	EA	1	\$ 3,500.00	\$ 3,500.00
7	F&I Casting Assembly – Storm	EA	4	\$ 800.00	\$ 3,200.00
8	Random Rip Rap Class III	CY	5	\$ 150.00	\$ 750.00
<i>Total Storm Sewer Construction Cost</i>					<i>\$ 39,247.50</i>
<i>5% Contingency Cost</i>					<i>\$ 1,962.38</i>
<i>23% Indirect Cost</i>					<i>\$ 9,478.27</i>
<i>Total Storm Sewer Project Cost</i>					<i>\$ 50,688.15</i>
<b>Total Estimated Project Cost</b>					<b>\$ 502,555.46</b>



# BROOKVIEW ESTATES ASSESSABLE PROPERTIES

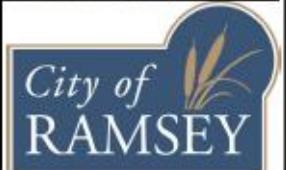
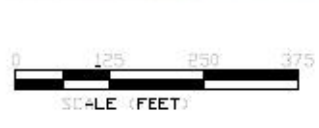

**PRELIMINARY ASSESSMENT ROLL – 19-02 BROOKVIEW ESTATES STREET RECONSTRUCTIONS**

<b>PID</b>	<b>NAME / OWNER</b>	<b>ADDRESS</b>	<b>CITY</b>	<b>STATE</b>	<b>ZIP</b>	<b>ASSESSABLE UNITS</b>	<b>PROPOSED ASSESSMENT</b>
013225330002	MC SHANE DANIEL M	17310 GERMANIUM ST NW	RAMSEY	MN	55303	1	\$ 4,418.30
013225330003	LADEEN JULIE A & MARK A	17330 GERMANIUM ST NW	RAMSEY	MN	55303	1	\$ 4,418.30
013225330004	JONES DAVID J & DEBORAH A	17331 GERMANIUM ST NW	RAMSEY	MN	55303	1	\$ 4,418.30
013225330005	LUND DONALD N & MARGERY A	17311 GERMANIUM ST NW	RAMSEY	MN	55303	1	\$ 4,418.30
013225330006	NORCUTT TRUSTEE KATHLEEN & NORCUTT TRUSTEE RICHARD	17301 GERMANIUM ST NW	RAMSEY	MN	55303	1	\$ 4,418.30
013225330007	NACHTWEY MICHAEL F & MARY J		RAMSEY	MN	55303	1	\$ 4,418.30
013225330008	ROHL MORRIS G & SHARON L	5451 173 <sup>RD</sup> AVE NW	RAMSEY	MN	55303	1	\$ 4,418.30
013225330009	STEFFEN JAMES W & LISA F	5431 173 <sup>RD</sup> AVE NW	RAMSEY	MN	55303	1	\$ 4,418.30
013225330010	VOSS WALTER W & SALLY	5401 173 <sup>RD</sup> AVE NW	RAMSEY	MN	55303	1	\$ 4,418.30
113225110007	CHUBB JEREMY	17200 GERMANIUM ST NW	RAMSEY	MN	55303	1	\$ 4,418.30
113225110009	OSHAUGHNESSY CORRIN	17228 GERMANIUM ST NW	RAMSEY	MN	55303	1	\$ 4,418.30
113225110010	OSHAUGHNESSY CORRIN		RAMSEY	MN	55303	1	\$ 4,418.30
123225220003	PLACHECKI HALI	5410 173 <sup>RD</sup> AVE NW	RAMSEY	MN	55303	1	\$ 4,418.30
123225220004	ONGIE CHERYL	5420 173 <sup>RD</sup> AVE NW	RAMSEY	MN	55303	1	\$ 4,418.30
123225220005	WEBER JAMES J & DIANE M	5450 173 <sup>RD</sup> AVE NW	RAMSEY	MN	55303	1	\$ 4,418.30
123225220006	KREYER GARY R & JUDITH G	5510 173 <sup>RD</sup> AVE NW	RAMSEY	MN	55303	1	\$ 4,418.30
123225220007	PETERSON SEAN	5530 173 <sup>RD</sup> AVE NW	RAMSEY	MN	55303	1	\$ 4,418.30
123225220008	BOEHLAND LYNN C & JOY L	17211 GERMANIUM ST NW	RAMSEY	MN	55303	1	\$ 4,418.30
123225220009	RAMSEY CITY OF	17201 GERMANIUM ST NW	RAMSEY	MN	55303	1	\$ 4,418.30
123225220010	ABERLE RICHARD N & CLAUDIA M	17290 GERMANIUM ST NW	RAMSEY	MN	55303	1	\$ 4,418.30
123225220011	KANIA HENRY & JANINA	17230 GERMANIUM ST NW	RAMSEY	MN	55303	1	\$ 4,418.30
<b>TOTALS</b>						<b>21</b>	<b>\$ 92,784.30</b>

## **APPENDIX C**

### **Street Segment Summary Ground Penetrating Radar (GPR) Results Geotechnical Exploration and Engineering Review**

### STREET SEGMENT SUMMARY

<b>Street</b>	<b>Segment Description</b>	<b>Length</b>	<b>Width</b>	<b>Curb</b>	<b>2018 Rating</b>	<b>Year Built</b>	<b>Maint. 1</b>	<b>Maint. 2</b>
173 <sup>rd</sup> Avenue	Germanium Street / CDS	853	24	n/a	3	1979	OL 1993	SC 1 2001
Germanium Street	170 <sup>th</sup> Lane / CDS	1,809	24	n/a	3	1979	OL 1993	SC 1 2001

## Brookview Estates GPR Summary

Project Segment		Pavement			Aggregate			Section		
Street	Segment Description	Min	Max	Med	Min	Max	Med	Med	Min	Location
173rd Avenue	Germanium Street / CDS	*								
Germanium Street	170th Lane / CDS	2.0	6.0	3.6	0.8	5.0	2.7	6.2	3.7	310' north of 173rd Avenue.
<i>Project Summary</i>		<i>2.0</i>	<i>6.0</i>	<i>3.6</i>	<i>0.8</i>	<i>5.0</i>	<i>2.7</i>	<i>6.2</i>	<i>3.7</i>	<i>Germanium Street 310 feet north of 173rd Avenue.</i>

\* GPR Data was not able to be conducted along street segments.

### GPR Data (Germanium Street: 170th Lane to CDS)

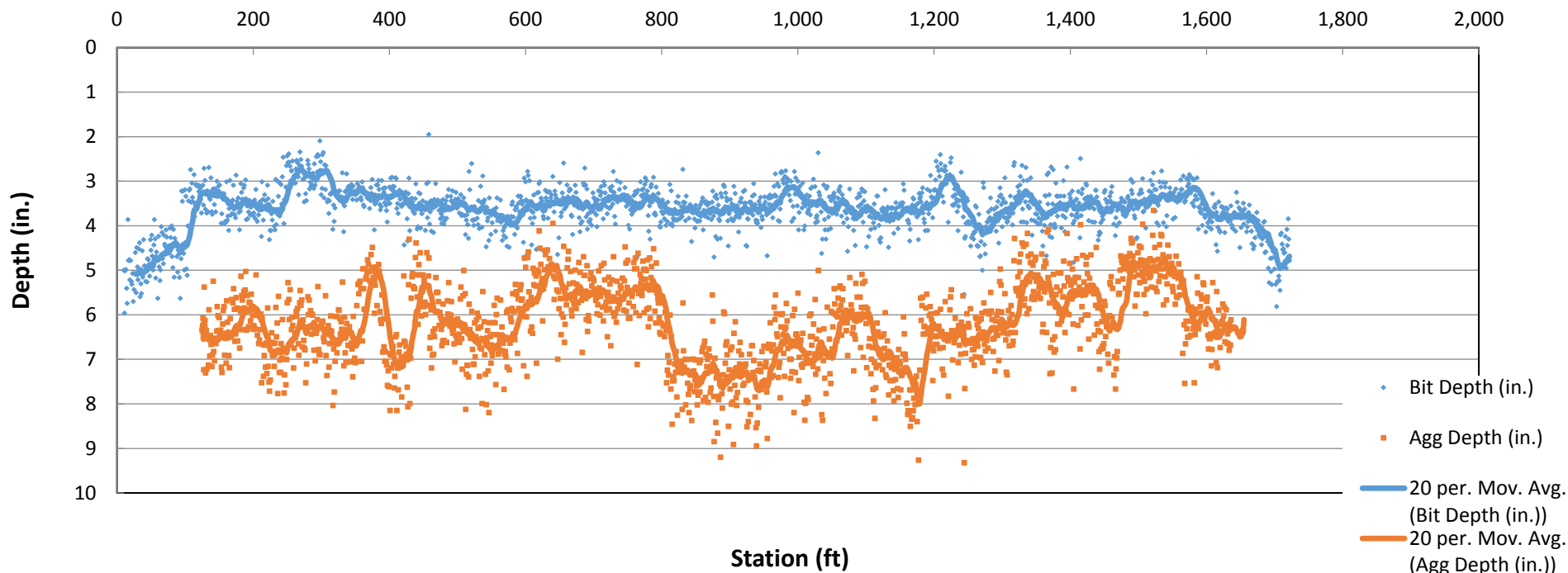



## GEOTECHNICAL EXPLORATION AND ENGINEERING REVIEW

*Brookview Estates Reconstruction*

*Ramsey*

*Minnesota*

*NTI Project No. 18.MSP06855.000*

***Prepared For:***

City of Ramsey  
7550 Sunwood Drive  
Ramsey, Minnesota 55303

---



**NTI**<sup>™</sup>  
NORTHERN  
TECHNOLOGIES, LLC

6160 Carmen Avenue East  
Inver Grove Heights, MN 55076  
P: 651.389.4191 F: 651.389.4190

www.NTIgeo.com

Unearthing confidence<sup>™</sup>

October 8, 2018

City of Ramsey  
Attention: Mr. Joe Feriancek  
7550 Sunwood Drive  
Ramsey, Minnesota 55303

Subject: Geotechnical Exploration and Engineering Review  
**Brookview Estates Reconstruction**  
Ramsey, Minnesota  
NTI Project No. 18.MSP06855.000

Northern Technologies, LLC (NTI) has completed a total of seven (7) soil borings in the Brookview Estates area. Our services were performed in accordance with our proposal dated September 4, 2018.

Soil samples obtained at the site will be held for 60 days at which time they will be discarded. Please advise us in writing if you wish to have us retain them for a longer period. You will be assessed an additional fee if soil samples are retained beyond 60 days.

We appreciate the opportunity to have been of service on this project. If there are any questions regarding the soils explored or our review and recommendations, please contact us at your convenience at (651) 389-4191.

**Northern Technologies, LLC**

Robert Hawkins, GIT  
Staff Geologist

Steven D. Gerber, P.E.  
Senior Engineer

I hereby certify that this plan, specification, or report was prepared by me or under my direct supervision and that I am a Duly Licensed Professional Engineer under the Laws of the State of Minnesota.

Steven D. Gerber

Date: 10/08/2018 Reg. No. 45298

Precision · Expertise · Geotechnical · Materials

FARGO · BISMARCK · GRANDFORKS · MINOT · INVERGROVEHEIGHTS · RAMSEY · RAPIDCITY · SIOUXFALLS



## Contents

<b>1.0</b>	<b>Scope of Services .....</b>	<b>1</b>
1.1	<i>Project and Site Description .....</i>	<i>1</i>
<b>2.0</b>	<b>Subsurface Exploration Summary .....</b>	<b>1</b>
2.1	<i>Groundwater and Groundwater Control .....</i>	<i>2</i>
2.2	<i>Laboratory Test Program .....</i>	<i>2</i>
2.3	<i>Utilities .....</i>	<i>3</i>
2.4	<i>Pavement Recommendations .....</i>	<i>3</i>
	<i>Full Reconstruction Option .....</i>	<i>3</i>
	<i>Mill and Overlay Option .....</i>	<i>5</i>
<b>3.0</b>	<b>Excavation Stability .....</b>	<b>6</b>
3.1	<i>Engineered Fill &amp; Winter Construction .....</i>	<i>6</i>
<b>4.0</b>	<b>Closure .....</b>	<b>6</b>

---



## 1.0 Scope of Services

Seven borings were in the project area. The scope of services included determining existing bituminous and aggregate base thicknesses, groundwater levels, subsurface conditions, and providing recommendations for site preparation, excavations, engineered fill and compaction, depths of unsuitable soils to be removed, groundwater management, potential difficulties during construction, utility construction, and pavement design thickness.

### 1.1 Project and Site Description

The project consists of the complete reconstruction of Germanium Street at 173<sup>rd</sup> Avenue in Ramsey, Minnesota. NTI was not aware of invert elevations or other design details of the proposed utilities at the time this report was prepared.

The pavement sections are proposed to be designed with a 20-year design pavement life. NTI has assumed an AADT value of 600 for these residential streets.

## 2.0 Subsurface Exploration Summary

NTI performed the subsurface exploration program during the period of September 26, 2018 with a two-person crew using a truck-mounted CME-55 drill rig. Samples were generally collected in accordance with ASTM D 1586 "Standard Test Method for Standard Penetration Testing (SPT) and Split-Barrel Sampling of Soils." The boring locations and depths were determined by a representative of the City of Ramsey. The boring locations were marked in the field by NTI. The borings terminated at depths ranging from approximately 10.5 to 20.5 feet below the top of pavement. Elevations were determined using a Trimble GeoXH 6000 and rounded to the nearest one-half foot.

Please refer to the Boring Location Diagrams and the Boring Logs in Appendix C.

Groundwater was observed at depths ranging between 6.5 and 9 feet below the ground surface, correspond to elevations ranging between 876.5 and 872.5.

The lack of observed groundwater in the remaining borings is likely due to the short duration for which the boreholes remained open. In addition, the seams of on-site clay and silt laden soils have the potential to be somewhat impervious and conducive to the development of zones of perched water at varying elevations and locations across the project area. Please refer to the boring log included in the appendices.

Table 1 summarizes the encountered subsurface conditions encountered.



Table 1: Pavement and Subgrade Summary<sup>1</sup>

Boring No.	Bituminous Pavement Thickness <sup>2</sup> (inches)	Apparent Aggregate Base Thickness <sup>3</sup> (inches)	Fill Subgrade Material <sup>4</sup>	Native Subgrade Material <sup>5</sup>
SB-1	4 ½	5	SC	SM
SB-2	2 ¼	4	SP-SM	SP
SB-3	4 ½	4	SM	SM
SB-4	4 ½	5	SP-SM	SP-SM
SB-5	5	6	SM	SP-SM
SB-6	5	6	SM	SM
SB-7	4 ¼	6	SM	CL

1. Table summary is a generalization of subsurface conditions at the individual soil boring locations only. They may not reflect variations in subsurface strata occurring on site between boring locations. The general geologic origin of retained soil samples is listed on the boring logs.
2. Measured thickness of the pavement core.
3. Apparent aggregate base thickness, at time of our fieldwork, by visual inspection only and is not meant to confer conformance with DOT specifications.
4. Undocumented fill soils were encountered immediately under the aggregate base.
5. The native soils underlying the undocumented fill soils.

## 2.1 Groundwater and Groundwater Control

Groundwater was observed at the time of drilling. Groundwater was observed in four of the seventeen boreholes the Interstate Area ranging from depths of approximately 6.5 to 8.0 feet below the top of pavement. The lack of observed groundwater at the remaining boring locations may be due to the short duration for which the boreholes remained open combined with the low permeability of the on-site clay and silt based soils. In addition, the on-site clay and silt based soils have the potential to be somewhat impervious and conducive to the development of zones of perched water at varying elevations and locations across the project area.

## 2.2 Laboratory Test Program

Our analysis and recommendations of this report are based upon our interpretation of the standard penetration test resistance determined while sampling soils, laboratory test results, and experience with similar soils from other sites near the project. The results of such tests are summarized on the boring logs or attached laboratory test reports.



## 2.3 Utilities

The fill and native soils observed in soil borings were generally suitable for utility support. Due to the observed groundwater levels and depending on the installation depth of the utilities, temporary dewatering would likely be required during the utility trench excavations for deeper utilities, such as sanitary sewer. Stabilization of the trench subgrade may be required, in particular in locations with lean clay subgrade, in order to provide a stable platform for construction. Stabilization could consist of a one half to one foot layer of crushed rock or sand with a maximum 5 percent material passing the No. 200 sieve and 50 percent passing the No. 40 sieve.

The Geotechnical Engineer of Record or their designated representative should observe the project excavations to determine that unsuitable materials have been properly removed and adequate bearing support is provided by the exposed soils. The exposed soil at the base should be compacted with a vibratory roller to 95 percent standard Proctor dry density (ASTM D698). Such observations and testing should be performed prior to backfilling.

The on-site, non-organic soils are anticipated to be suitable for reuse if properly moisture conditioned and compacted. Replacement backfill required in utility trenches should consist of non-organic material similar to the surrounding soil. All import fill should be approved by NTI or the City's representative.

It is especially important that trench backfill for utility construction within paved areas be thoroughly compacted to minimize future pavement damage. We recommend that such soils be compacted in accordance with the recommendations noted in the "Placement and Compaction of Engineered Fill" section in Appendix B of this report.

The stability of embankments along utility excavations is dependent on soil strength, site geometry, moisture content, and any surcharge load for excavated soils and equipment. We present cautionary remarks concerning stability of excavation sideslopes in the "Excavation Stability" section of this report.

The Contractor is solely responsible for assessing the stability of and executing underground utility and project excavations using safe methods. The contractor is also responsible for naming the "competent individual" as per Subpart P of 29 CFR 1926.6 (Federal Register - OSHA).

## 2.4 Pavement Recommendations

### Full Reconstruction Option

The most conservative method of subgrade preparation would be to remove the undocumented fill soils and replace them in their entirety with properly compacted engineered fill. This method of subgrade preparation would provide the most uniform subgrade but would also be the most costly method of construction and would be a relatively atypical method of subgrade preparation for improvements to existing municipal roadways.

If the City were willing to accept some risk in potential long term increased maintenance of the pavement section for the significant upfront savings, the roadway can be reconstructed over the existing fill.



The Contractor should be aware that the silty subgrade soils will be moisture-sensitive, and protecting them from inclement weather will aid in maintaining stability. The stripping of the existing pavement and aggregate base course should occur immediately prior to subgrade preparation and base aggregate installation to minimize weather-induced instability.

Prior to installing the aggregate base, the existing subgrade should be scarified and re-compacted to a depth of at least 12 inches. A proof roll test should then be performed to determine soft or unstable subgrade areas.

The proof roll should be performed with a tandem axle dump truck loaded to gross capacity (at least 20 tons). Acceptance criteria of the proof roll shall be limited to rut formation no more than one inch depth (front or rear axles) and no pumping (rolling) observed during the visual inspection. Proof roll tests should be observed by an experienced technician or geotechnical engineer prior to placement of the aggregate base course to verify the subgrade will provide adequate pavement support.

If rutting or localized unstable subgrade areas are observed, those areas should be subcut, moisture-conditioned, and re-compacted or removed to a stable depth.

If imported fill is required in paved areas, it should consist of debris-free, non-organic, mineral soil similar in composition to the subgrade soils encountered in the surrounding areas. If sand is imported into areas that are underlain by relatively impervious fine grained soils, the sand layer must be drained with drain tile in order to prevent frost heave from water trapped within the imported sand layer during freezing temperatures. Individual lifts of engineered fill should be tempered for moisture content, placed, and compacted as noted in the "Placement and Compaction of Engineered Fill" section in Appendix B of this report.

For a 20-year design pavement life, Tables 4 presents our thickness recommendations for flexible (bituminous) pavement. These recommendations were based upon the encountered subgrade conditions, estimated R-value of 30 for the existing subgrade soils, the assumed AADT volumes, and the City of Ramsey's typical pavement section for the respective project area.

**Table 4: Flexible Pavement Thickness Design<sup>1</sup>  
Interstate Area – Residential Area**

Pavement Section	Calculated Required Pavement Section <sup>2</sup>	City's Typical Pavement Section <sup>3</sup>
Bituminous Wear Course (inches)	2	1.5
Bituminous Base Course (inches)	2	2
Class 5 or 7 Aggregate Base (inches)	4	4

1. Assumed AADT volume of 600 and an average R-value of 30.
2. Assumed a minimum of 12 inches of engineered subgrade.
3. The subgrade appeared to be less firm at SB-2 and SB-7 (locations closest to the Rum River). Consideration could be made to using the City's standard section in locations north of SB-2 and west of SB-6.



Pavement recommendations assume the subgrade soils and aggregate section below paved surfaces will drain to subsurface piping for eventual discharge into storm sewer, or above grade to ditching, or similar acceptable systems. Lack of surface and subsurface drainage will significantly reduce the capacity and longevity of the pavement systems indicated above.

We recommend pavements receive annual maintenance, as a minimum, to correct damages to the pavement structure, clean and infill cracks which develop, and repair or resurface areas which exhibit reduced subgrade performance. The lack of maintenance can lead to moisture infiltration of the pavement structure and softening of the subgrade soils. This, in turn, can degrade the performance of the pavement system and result in poorly performing pavements with shortened life expectancy.

### Mill and Overlay Option

Portions of the roadway sections appear to have a sufficiently thick, in-place pavement section, which would lend itself to rehabilitation via mill and overlay techniques.

The existing pavement thickness generally about 4 ½ inches thick, but locally was observed to be about 2 ½ inches thick. If a mill and overlay were performed, we would recommend that thin pavement areas (such as near SB-2) and distressed pavement areas be removed and replaced with a full depth (6 inch) patch.

Full depth reclamation (FDR) would be feasible for this project area. Usually a blend of mineral aggregate base with the bituminous pavement is blended and the teeth of the reclaimers need to extend beyond the bituminous layers in order to prevent overheating.

The pavement could be milled off and removed and replaced with fresh bituminous pavement. The millings can be blended with on-site aggregate base, with imported aggregate base or remixed at the plant to provide fresh aggregate base. The blended material should contain no more than 50 percent bituminous millings. In general, locations suitable for FDR would have aggregate base that is about the same thickness as the pavement plus 3 to 4 inches remaining to support the weight of the heavy machinery required for FDR.

We recommend that the base be proof-rolled prior to placement of the new pavement materials to determine soft or unstable subgrade areas. The proof roll should be performed with a tandem axle dump truck loaded to gross capacity (at least 20 tons). Acceptance criteria of the proof roll shall be limited to rut formation no more than one inch (1") depth (front or rear axles) and no pumping (rolling) observed during the visual inspection. Proof roll tests should be observed by an experienced technician or geotechnical engineer prior to placement of the aggregate base course to verify the subgrade will provide adequate pavement support.

If rutting or localized unstable subgrade areas are observed, those areas should be subcut, moisture-conditioned, and re-compacted or removed to a stable depth. Excavations for soil corrections (if any) in paved areas should allow for a 2 foot oversize beyond the edges of the pavement.



If imported fill is required in paved areas, it should consist of debris-free, non-organic, mineral soil similar in composition to the subgrade soils encountered in the surrounding areas. If sand is imported into areas that are underlain by relatively impervious fine-grained soils, the sand layer must be drained with drain tile in order to prevent frost heave from water trapped within the imported sand layer during freezing temperatures. Individual lifts of engineered fill should be tempered for moisture content, placed, and compacted as noted in the “Placement and Compaction of Engineered Fill” section in Appendix B of this report.

### **3.0 Excavation Stability**

Excavation depth and sidewall inclination should not exceed those specified in local, state, or federal regulations. Excavations may need to be widened and sloped, or temporarily braced, to maintain or develop a safe work environment. Contractors must comply with local, state, and federal safety regulations including current OSHA excavation and trench safety standards. Temporary shoring must be designed in accordance with applicable regulatory requirements.

#### **3.1 Engineered Fill & Winter Construction**

The silt and clay laden soils encountered at the project locations will be susceptible to freezing if not provided adequate drainage, insulation, or coverage. Frozen soil should not be used as backfill. When the ambient air temperature falls below freezing for an extended period of time, frost forms, and soil near the surface grade expands. Settlement of the fill may occur as the frozen soils thaw.

If frost penetrates the soil prior to paving, soils must be thawed, scarified, and re-compacted as recommended in this report. Subgrade soils should be inspected prior to paving to verify frozen conditions are not present.

### **4.0 Closure**

As the widely spaced, small diameter borings provide only a limited amount of data regarding the existing fill, the existing fill may contain soft zones, debris or significantly greater amounts of unsuitable materials than could be reasonably inferred from the boring information. Unsuitable materials may not be discovered during construction and may remain buried within the fill below the pavement, resulting in greater than anticipated settlements of the pavement. These risks cannot be eliminated without completely removing the fill, but can be reduced by thorough exploration and testing during site preparation and construction.

Our conclusions and recommendations are predicated on observation and testing of the earthwork directed by Geotechnical Engineer of Record. Our opinions are based on data assumed representative of the project area. However, the area coverage of borings in relation to the entire project is very small. For this and other reasons, we do not warrant conditions below the depth of our borings, or that the strata logged from our borings are necessarily typical of the site. Deviations from our recommendations by plans, written specifications, or field applications shall relieve us of responsibility unless our written concurrence with such deviations has been established.



The scope of services for this project does not include either specifically or by implication any environmental or biological assessment of the site or identification or prevention of pollutants, hazardous materials or conditions. If the owner is concerned about the potential for such contamination or pollution, other studies should be undertaken.

This report has been prepared for the exclusive use of the City of Ramsey for specific application to the proposed Brookview Estates Street Reconstructions, in Ramsey, Minnesota. Northern Technologies, LLC has endeavored to comply with generally accepted geotechnical engineering practice common to the local area. Northern Technologies, LLC makes no other warranty, express or implied.

**Northern Technologies, LLC**



## APPENDIX A

GEOTECHNICAL EVALUATION OF RECOVERED SOIL SAMPLES

FIELD EXPLORATION PROCEDURES

GENERAL NOTES

WATER LEVEL SYMBOL

DESCRIPTIVE TERMINOLOGY

RELATIVE PROPORTIONS

PARTICLE SIZES

CLASSIFICATION OF SOILS FOR ENGINEERING PURPOSES

---



---

## GEOTECHNICAL EVALUATION OF RECOVERED SOIL SAMPLES

We visually examined recovered soil samples to estimate distribution of grain sizes, plasticity, consistency, moisture condition, color, presence of lenses and seams, and apparent geologic origin. We then classified the soils according using the Unified Soil Classification System (ASTM D2488). A chart describing this classification system and general notes explaining soil sampling procedures are presented within appendices attachments.

The stratification depth lines between soil types on the logs are estimated based on the available data. In-situ, the transition between type(s) may be distinct or gradual in either the horizontal or vertical directions. The soil conditions have been established at our specific boring locations only. Variations in the soil stratigraphy may occur between and around the borings, with the nature and extent of such change not readily evident until exposed by excavation. These variations must be properly assessed when utilizing information presented on the boring logs.

We request that you, your design team or contractors contact NTI immediately if local conditions differ from those assumed by this report, as we would need to review how such changes impact our recommendations. Such contact would also allow us to revise our recommendations as necessary to account for the changed site conditions.

### FIELD EXPLORATION PROCEDURES

#### ***Soil Sampling – Standard Penetration Boring:***

Soil sampling was performed according to the procedures described by ASTM D-1586. Using this procedure, a 2 inch O.D. split barrel sampler is driven into the soil by a 140 pound weight falling 30 inches. After an initial set of six inches, the number of blows required to drive the sampler an additional 12 inches is recorded (known as the penetration resistance (i.e. “N-value”) of the soil at the point of sampling. The N-value is an index of the relative density of cohesionless soils and an approximation of the consistency of cohesive soils.

#### ***Soil Sampling – Power Auger Boring:***

The boring(s) was/were advanced with a 6 inch nominal diameter continuous flight auger. As a result, samples recovered from the boring are disturbed, and our determination of the depth, extend of various stratum and layers, and relative density or consistency of the soils is approximate.

#### ***Soil Classification:***

Soil samples were visually and manually classified in general conformance with ASTM D-2488 as they were removed from the sampler(s). Representative fractions of soil samples were then sealed within respective containers and returned to the laboratory for further examination and verification of the field classification. In addition, select samples were submitted for laboratory tests. Individual sample information, identification of sampling methods, method of advancement of the samples and other pertinent information concerning the soil samples are presented on boring logs and related report attachments.

---



**GENERAL NOTES**

<i>DRILLING and SAMPLING SYMBOLS</i>		<i>LABORATORY TEST SYMBOLS</i>	
<b>SYMBOL</b>	<b>DEFINITION</b>	<b>SYMBOL</b>	<b>DEFINITION</b>
C.S.	Continuous Sampling	W	Moisture content-percent of dry weight
P.D.	2-3/8" Pipe Drill	D	Dry Density-pounds per cubic foot
C.O.	Cleanout Tube	LL, PL	Liquid and plastic limits determined in accordance with ASTM D 423 and D 424
3 HSA	3 1/4" I.D. Hollow Stem Auger	Q <sub>u</sub>	Unconfined compressive strength-pounds per square foot in accordance with ASTM D 2166-66
4 FA	4" Diameter Flight Auger		
6 FA	6" Diameter Flight Auger		
2 1/2 C	2 1/2" Casing		
4 C	4" Casing		
D.M.	Drilling Mud	Pq	Penetrometer reading-tons/square foot
J.W.	Jet Water	S	Torvane reading-tons/square foot
H.A.	Hand Auger	G	Specific Gravity – ASTM D 854-58
NXC	Size NX Casing	SL	Shrinkage limit – ASTM 427-61
BXC	Size BX Casing	Ph	Hydrogen ion content-meter method
AXC	Size AX casing	O	Organic content-combustion method
SS	2" O.D. Split Spoon Sample	M.A.	Grain size analysis
2T	2" Thin Wall Tube Sample	C*	One dimensional consolidation
3T	3" Thin Wall Tube Sample	Q <sub>c</sub>	Triaxial Compression

\* See attached data Sheet and/or graph

**WATER LEVEL SYMBOL**

Water levels shown on the boring logs were determined at the time and under the conditions indicated. In sand, the indicated levels can be considered relatively reliable for most site conditions. In clay soils, it is not possible to determine the ground water level within the normal scope of a test boring investigation, except where lenses or layers of more pervious water bearing soil are present; and then a long period of time may be necessary to reach equilibrium. Therefore, the position of the water level symbol for cohesive or mixed soils may not indicate the true level of the ground water table. The available water level information is given at the bottom of the log sheet.

**DESCRIPTIVE TERMINOLOGY**

<i>RELATIVE DENSITY</i>		<i>CONSISTENCY</i>	
<b>TERM</b>	<b>N<sub>60</sub> Value (corrected)</b>	<b>TERM</b>	<b>N<sub>60</sub> Value (corrected)</b>
Very Loose	0 – 4	Soft	0-4
Loose	5 – 8	Medium	5-8
Medium Dense	9 – 16	Rather Stiff	9 – 15
Dense	16 – 30	Stiff	16 – 30
Very Dense	Over 30	Very Stiff	Over 30

**RELATIVE PROPORTIONS**

<b>TERMS</b>	<b>RANGE</b>
Trace	0 – 5%
A little	5 – 15%
Some	15 – 30%

**PARTICLE SIZES**

<b>MATERIAL</b>	<b>DESCRIPTION</b>	<b>U.S. SIEVE SIZE</b>
Boulders		Over 3"
Gravel	Coarse	3" to 3/4"
	Medium	3/4" to #4
Sand	Coarse	#4 to #10
	Medium	#10 to #40
	Fine	#40 to #200
Silt and Clay	Determined by Hydrometer Test	



## CLASSIFICATION of SOILS for ENGINEERING PURPOSES

ASTM Designation D-2487 and D2488 (Unified Soil Classification System)

Major Divisions	Group Symbol	Typical Name	Classification Criteria	
<b>Course Grained Soils</b> More than 50% retained on No. 200 sieve *	Gravels 50% or more of coarse fraction retained on No. 4 sieve.	Clean Gravels	<b>GW</b> Well-graded gravels and gravel-sand mixtures, little or no fines.	<p><b>Classification on basis of percentage of fines.</b>            Less than 5% passing No. 200 Sieve: GW, GP, SW, SP            More than 12% passing No. 200 Sieve: GM, GC, SM, SC            From 5% to 12% passing No. 200 Sieve: Borderline Classification requiring use of dual symbols.</p> <p>Cu = D60 / D10 greater than 4.            Cz = (D30)<sup>2</sup> / (D10 x D60) between 1 &amp; 3.</p> <p>Not meeting both criteria for GW materials.</p> <p>Atterberg limits below "A" line, or P.I. less than 4.            Atterberg limits above "A" line with P.I. greater than 7.</p> <p>Atterberg limits plotting in hatched area are borderline classifications requiring use of dual symbols.</p>
		Gravels with Fines	<b>GP</b> Poorly graded gravels and gravel-sand mixtures, little or no fines.	
			<b>GM</b> Silty gravels, gravel-sand-silt mixtures.	
			<b>GC</b> Clayey gravels, gravel-sand-clay mixtures.	
	Sands More than 50% of coarse fraction passes No. 4 sieve.	Clean Sands	<b>SW</b> Well-graded sands and gravelly sands, little or no fines.	<p>Cu = D60 / D10 greater than 6.            Cz = (D30)<sup>2</sup> / (D10 x D60) between 1 &amp; 3.</p> <p>Not meeting both criteria for SW materials.</p> <p>Atterberg limits below "A" line, or P.I. less than 4.            Atterberg limits above "A" line with P.I. &gt; 7.</p> <p>Atterberg limits plotting in hatched area are borderline classifications requiring use of dual symbols.</p>
		Clean Sands	<b>SP</b> Poorly-graded sands and gravelly sands, little or no fines.	
		Sands with Fines	<b>SM</b> Silty sands, sand-silt mixtures.	
		Sands with Fines	<b>SC</b> Clayey sands, sand-clay mixtures.	
	<b>Fine Grained Soils</b> More than 50% passes No. 200 sieve *	Silts and Clays Liquid Limit of 50% or less	<b>ML</b> Inorganic silts, very fine sands, rock flour, silty or clayey fine sands.	
			<b>CL</b> Inorganic clays of low to medium plasticity, gravelly clays, sandy clays, silty clays, lean clays.	
<b>OL</b> Organic silts and organic silty clays of low plasticity.				
<b>MH</b> Inorganic silts, micaceous or diatomaceous fine sands or silts, elastic silts.				
Silts and Clays Liquid Limit greater than 50%.		<b>CH</b> Inorganic clays of high plasticity, fat clays.	<p>OH &amp; MH Soils</p> <p>OL &amp; ML Soils</p>	
		<b>OH</b> Organic clays of medium to high plasticity.		
Highly Organic Soils		<b>Pt</b> Peat, muck and other highly organic soils.		



## APPENDIX B

**GROUNDWATER ISSUES**

**PLACEMENT and COMPACTION OF ENGINEERED FILL**

---



## GROUNDWATER ISSUES

***The following presents additional comment and soil specific issues related to measurement of groundwater conditions at your project site.***

Note that our groundwater measurements, or lack thereof, will vary depending on the time allowed for equilibrium to occur in the borings. Extended observation time was not available during the scope of the field exploration program and, therefore, groundwater measurements as noted on the borings logs may or may not accurately reflect actual conditions at your site.

Seasonal and yearly fluctuations of the ground water level, if any, occur. Perched groundwater may be present within sand and silt lenses bedded within cohesive soil formations. Groundwater typically exists at depth within cohesive and cohesionless soils.

Documentation of the local groundwater surface and any perched groundwater conditions at the project site would require installation of temporary piezometers and extended monitoring due to the relatively low permeability exhibited by the site soils. We have not performed such groundwater evaluation due to the scope of services authorized for this project.

We anticipate that a system of sump pits and pumps located outside of the foundation areas would be suitable for control if perched groundwater were to be encountered. NTI cautions that such seepage may be heavy and will vary based on seasonal and annual precipitation, and ground related impacts in the vicinity of the project.

We anticipate that a well point system would be suitable for control of groundwater if excavations were to be advanced into the ground water table at depth in free draining granular soils. However, we caution such seepage from such formations and any water entry from excavations below the groundwater table may be heavy and will vary based on seasonal and annual precipitation, and ground related impacts in the vicinity of the project.

---



**PLACEMENT and COMPACTION OF ENGINEERED FILL**

***Unless otherwise superseded within the body of the Geotechnical Exploration Report, the following criteria shall be utilized for placement of engineered fill on project. This includes, but is not limited to earthen fill placement to improve site grades, fill placed below structural footings, fill placed interior of structure, and fill placed as backfill of foundations.***

Engineered fill placed for construction, if necessary should consist of natural, non-organic, competent soils native to the project area. Such soils may include, but are not limited to gravel, sand, or clays with Unified Soil Classification System (ASTM D2488) classifications of GW, SP, or SM. Use of silt or clayey silt as project fill will require additional review and approval of project Geotechnical Engineer of Record. Such soils have USCS classifications of ML, MH, ML-CL, MH-CH. Use of topsoil, marl, peat, other organic soils construction debris and/or other unsuitable materials as fill is not allowed. Such soils have USCS classifications of OL, OH, Pt.

Engineered fill, classified as clay, should be tempered such that the moisture content at the time of placement is equal to and no more than 3 percent above the optimum content for as defined by the appropriate proctor test. Likewise, engineered fill classified as gravel or sand should be tempered such that the moisture content at the time of placement is within 3 percent of the optimum content.

All engineered fill for construction should be placed in individual 8 inch maximum depth lifts. Each lift of fill should be compacted by large vibratory equipment until the in-place soil density is equal to or greater than the criteria established within the following tabulation.

Type of Construction	Compaction Criteria (% respective Proctor) <sup>1</sup>	
	Clay	Sand or Gravel
Engineered Fill placed as Pavement Subgrade (more than 3 feet below bottom of final grade)	Min. 95	Min. 95
Engineered Fill placed as Pavement Subgrade (less than 3 feet below bottom of final grade)	Min. 100	Min. 100
Engineered Fill placed as Pavement Aggregate Base	NA	Min. 100

1. Note 1 Unless otherwise required, compaction criteria shall be based on the Standard Proctor Test (ASTM D698).

Density tests should be taken during engineered fill placement to document earthwork has achieved necessary compaction of the material(s). Recommendations for interior fill placement and backfill of foundation walls are presented within other sections of this report.



## APPENDIX C

**BORING LOCATION DIAGRAM**

**SOIL BORING LOGS**

---



Boring Location Diagram  
Brookview Estates Street Reconstructions  
Ramsey, Minnesota  
NTI Project #: 18.MSP06855.000  
NOTE: Boring locations are approximate.

Completed Boring Locations: ●





**Inver Grove Heights**  
 6160 Carmen Avenue East  
 Inver Grove Heights, MN, 55076  
 P: 651-389-4191

**BORING NUMBER SB-1**

**CLIENT** City of Ramsey **PROJECT NAME** Brookview Estates Street Reconstructions  
**PROJECT NUMBER** 18.MS06855.000 **PROJECT LOCATION** Ramsey, MN  
**DATE STARTED** 9/26/18 **COMPLETED** 9/26/18 **GROUND ELEVATION** 884 feet **HOLE SIZE** 6 1/2 in.  
**DRILLING CONTRACTOR** NTI **GROUND WATER LEVELS:**  
**DRILLING METHOD** 3 1/4 in H.S.A **AT TIME OF DRILLING** --- No Groundwater Observed.  
**LOGGED BY** RRH **CHECKED BY** SDG **AT END OF DRILLING** ---  
**CAVE IN (ft)** --- **FROST DEPTH (ft)** --- **AFTER DRILLING** ---  
**NOTES** Elevation determined using a Trimble GeoXH 6000(NAVD 88 GeoID 09 datum).

NTI LOG - GENERAL (USE THIS ONE) - NTI-2017-09-14.GDT - 10/4/18 10:51 - R:RAMSEY\Y1-PROJECT\SB1-BROOKVIEW ESTATES & STREET RECON\_GEO\_18.MSP\_06855.000\TESTING REPORT\SB1-BROOKVIEW ESTATES.GPJ

DEPTH (ft)	GRAPHIC LOG	MATERIAL DESCRIPTION	SAMPLE TYPE NUMBER	RECOVERY % (RQD)	BLOW COUNTS (N VALUE)	POCKET PEN. (tsf)	DRY UNIT WT. (pcf)	MOISTURE CONTENT (%)	ATTERBERG LIMITS			FINES
									LIQUID LIMIT	PLASTIC LIMIT	PLASTICITY INDEX	
0												
0.4		BITUMINOUS PAVEMENT (4 1/2 Inches)	883.6									
0.8		APPARENT AGGREGATE BASE (5 Inches)	883.2									
1.5		CLAYEY SAND, (SC) black, fine grained, moist, trace gravel <b>(Undocumented Fill)</b> NOTE: Organic content in sample 1 = 3.2%.	882.5	SS 1	89	4-3-3 (6)		17				
		SILTY SAND, (SM) brown, fine grained, moist, trace gravel (Alluvial)	880.0	SS 2	100	7-14-16 (30)						
4.0		POORLY GRADED SAND WITH SILT, (SP-SM) brown, fine grained, moist, medium dense, trace gravel (Alluvial)		SS 3	89	7-5-5 (10)		9				11
6.5		LEAN CLAY WITH SAND, (CL) brown, moist, medium, trace gravel (Alluvial)	877.5	SS 4	100	2-2-3 (5)		32				
9.0		CLAYEY SAND, (SC) brown to light brown, fine grained, moist, medium, stratified, trace gravel, with clay and sand layering (Alluvial)	875.0	SS 5	100	2-2-4 (6)						
10.5			873.5									

Bottom of borehole at 10.5 feet.



**Inver Grove Heights**  
 6160 Carmen Avenue East  
 Inver Grove Heights, MN, 55076  
 P: 651-389-4191

**BORING NUMBER SB-2**

**CLIENT** City of Ramsey **PROJECT NAME** Brookview Estates Street Reconstructions  
**PROJECT NUMBER** 18.MS06855.000 **PROJECT LOCATION** Ramsey, MN  
**DATE STARTED** 9/26/18 **COMPLETED** 9/26/18 **GROUND ELEVATION** 883.5 feet **HOLE SIZE** 6 1/2 in.  
**DRILLING CONTRACTOR** NTI **GROUND WATER LEVELS:**  
**DRILLING METHOD** 3 1/4 in H.S.A **▽ AT TIME OF DRILLING** 6.50 ft / Elev 877.00 ft  
**LOGGED BY** RRH **CHECKED BY** SDG **AT END OF DRILLING** ---  
**CAVE IN (ft)** --- **FROST DEPTH (ft)** --- **AFTER DRILLING** ---  
**NOTES** Elevation determined using a Trimble GeoXH 6000(NAVD 88 Geold 09 datum).

DEPTH (ft)	GRAPHIC LOG	MATERIAL DESCRIPTION	SAMPLE TYPE NUMBER	RECOVERY % (RQD)	BLOW COUNTS (N VALUE)	POCKET PEN. (tsf)	DRY UNIT WT. (pcf)	MOISTURE CONTENT (%)	ATTERBERG LIMITS			FINES
									LIQUID LIMIT	PLASTIC LIMIT	PLASTICITY INDEX	
0												
0.2		BITUMINOUS PAVEMENT (2 1/4 Inches)	AU									
0.5		APPARENT AGGREGATE BASE (4 Inches)	SS 1	100	5-6-9 (15)			6				
1.5		POORLY GRADED SAND WITH SILT, (SP-SM) dark brown, fine to medium grained, moist, trace gravel (Undocumented Fill)	SS 2	89	4-4-5 (9)							
		POORLY GRADED SAND, (SP) light brown, fine grained, moist, medium dense to very loose, trace gravel (Alluvial)	SS 3	100	3-4-4 (8)							
5		▽	SS 4	100	2-1-1 (2)							
10			SS 5	100	1-1-1 (2)							
13.0			SS	89	4-4-3 (7)							

Bottom of borehole at 13.0 feet.



**Inver Grove Heights**  
 6160 Carmen Avenue East  
 Inver Grove Heights, MN, 55076  
 P: 651-389-4191

**BORING NUMBER SB-3**

**CLIENT** City of Ramsey **PROJECT NAME** Brookview Estates Street Reconstructions  
**PROJECT NUMBER** 18.MS06855.000 **PROJECT LOCATION** Ramsey, MN  
**DATE STARTED** 9/26/18 **COMPLETED** 9/26/18 **GROUND ELEVATION** 883 feet **HOLE SIZE** 6 1/2 in.  
**DRILLING CONTRACTOR** NTI **GROUND WATER LEVELS:**  
**DRILLING METHOD** 3 1/4 in H.S.A  $\nabla$  **AT TIME OF DRILLING** 6.50 ft / Elev 876.50 ft  
**LOGGED BY** RRH **CHECKED BY** SDG **AT END OF DRILLING** ---  
**CAVE IN (ft)** --- **FROST DEPTH (ft)** --- **AFTER DRILLING** ---

**NOTES** Elevation determined using a Trimble GeoXH 6000(NAVD 88 Geold 09 datum).

DEPTH (ft)	GRAPHIC LOG	MATERIAL DESCRIPTION	SAMPLE TYPE NUMBER	RECOVERY % (RQD)	BLOW COUNTS (N VALUE)	POCKET PEN. (tsf)	DRY UNIT WT. (pcf)	MOISTURE CONTENT (%)	ATTERBERG LIMITS			FINES
									LIQUID LIMIT	PLASTIC LIMIT	PLASTICITY INDEX	
0												
0.4		BITUMINOUS PAVEMENT (4 1/2 Inches)	882.6	AU								
0.7		APPARENT AGGREGATE BASE (4 Inches)	882.3									
1.5		SILTY SAND, (SM) dark brown, fine grained, moist, trace gravel <b>(Undocumented Fill)</b>	881.5	SS 1	89	4-6-8 (14)						
		POORLY GRADED SAND WITH SILT, (SP-SM) brown, fine to medium grained, moist, loose to very loose, trace gravel (Alluvial)		SS 2	89	5-4-4 (8)		7				
				SS 3	100	3-2-3 (5)						
				SS 4	89	2-2-2 (4)						
9.0			874.0									
		LEAN CLAY WITH SAND, (CL) brown, moist, soft, trace gravel (Alluvial)		SS 5	100	2-1-1 (2)						
				SS 6	89	2-2-2 (4)		22				
13.0			870.0									
		LEAN TO FAT CLAY, (CH/CL) gray, moist, soft, trace gravel (Alluvial)		SS 7	100	2-1-1 (2)		46				
19.0			864.0									
		CLAYEY SAND, (SC) gray, moist, rather stiff, trace gravel (Glacial Till)		SS 8	100	6-7-7 (14)						
20.5			862.5									

Bottom of borehole at 20.5 feet.

NTI LOG - GENERAL (USE THIS ONE) - NTI-2017-09-14.GDT - 10/4/18 10:51 - R:RAMSEY11-PROJECTS2018 PROJECTS\BROOKVIEW ESTATES & STREET RECON\_GEO\_18.MSP\_06855.000\TESTING REPORTS\GINT\BROOKVIEW ESTATES.GPJ



**Inver Grove Heights**  
 6160 Carmen Avenue East  
 Inver Grove Heights, MN, 55076  
 P: 651-389-4191

**BORING NUMBER SB-4**

**CLIENT** City of Ramsey **PROJECT NAME** Brookview Estates Street Reconstructions  
**PROJECT NUMBER** 18.MS06855.000 **PROJECT LOCATION** Ramsey, MN  
**DATE STARTED** 9/26/18 **COMPLETED** 9/26/18 **GROUND ELEVATION** 883 feet **HOLE SIZE** 6 1/2 in.  
**DRILLING CONTRACTOR** NTI **GROUND WATER LEVELS:**  
**DRILLING METHOD** 3 1/4 in H.S.A **▽ AT TIME OF DRILLING** 6.50 ft / Elev 876.50 ft  
**LOGGED BY** RRH **CHECKED BY** SDG **AT END OF DRILLING** ---  
**CAVE IN (ft)** --- **FROST DEPTH (ft)** --- **AFTER DRILLING** ---  
**NOTES** Elevation determined using a Trimble GeoXH 6000(NAVD 88 Geold 09 datum).

NTI LOG - GENERAL (USE THIS ONE) - NTI-2017-09-14.GDT - 10/4/18 10:51 - R:RAMSEY\YI-PROJECT\SB\BROOKVIEW ESTATES & STREET RECON\_GEO\_18.MSP\_06855.000\TESTING REPORT\SGINT\BROOKVIEW ESTATES.GPJ

DEPTH (ft)	GRAPHIC LOG	MATERIAL DESCRIPTION	SAMPLE TYPE NUMBER	RECOVERY % (RQD)	BLOW COUNTS (N VALUE)	POCKET PEN. (tsf)	DRY UNIT WT. (pcf)	MOISTURE CONTENT (%)	ATTERBERG LIMITS			FINES
									LIQUID LIMIT	PLASTIC LIMIT	PLASTICITY INDEX	
0												
0.4		BITUMINOUS PAVEMENT (4 1/2 Inches)	882.6	AU								
0.8		APPARENT AGGREGATE BASE (5 Inches)	882.2									
1.5		POORLY GRADED SAND WITH SILT, (SP-SM) dark brown, moist, trace gravel <b>(Undocumented Fill)</b>	881.5	SS 1	100	5-6-9 (15)		6				11
		POORLY GRADED SAND WITH SILT, (SP-SM) brown to light brown, fine to medium grained, moist, medium dense to loose, trace gravel (Alluvial)		SS 2	89	5-5-5 (10)						
5				SS 3	100	3-3-3 (6)						
				SS 4	89	4-3-4 (7)						
9.0			874.0									
10		SANDY LEAN CLAY, (CL) brown, moist, medium, stratified, trace gravel, with silt (ML) layering (Alluvial)		SS 5	100	1-2-3 (5)		34				
10.5			872.5									

Bottom of borehole at 10.5 feet.



**Inver Grove Heights**  
 6160 Carmen Avenue East  
 Inver Grove Heights, MN, 55076  
 P: 651-389-4191

**BORING NUMBER SB-5**

**CLIENT** City of Ramsey **PROJECT NAME** Brookview Estates Street Reconstructions  
**PROJECT NUMBER** 18.MS06855.000 **PROJECT LOCATION** Ramsey, MN  
**DATE STARTED** 9/26/18 **COMPLETED** 9/26/18 **GROUND ELEVATION** 881.5 feet **HOLE SIZE** 6 1/2 in.  
**DRILLING CONTRACTOR** NTI **GROUND WATER LEVELS:**  
**DRILLING METHOD** 3 1/4 in H.S.A **▽ AT TIME OF DRILLING** 9.00 ft / Elev 872.50 ft  
**LOGGED BY** RRH **CHECKED BY** SDG **AT END OF DRILLING** ---  
**CAVE IN (ft)** --- **FROST DEPTH (ft)** --- **AFTER DRILLING** ---  
**NOTES** Elevation determined using a Trimble GeoXH 6000(NAVD 88 GeoID 09 datum).

DEPTH (ft)	GRAPHIC LOG	MATERIAL DESCRIPTION	SAMPLE TYPE NUMBER	RECOVERY % (RQD)	BLOW COUNTS (N VALUE)	POCKET PEN. (tsf)	DRY UNIT WT. (pcf)	MOISTURE CONTENT (%)	ATTERBERG LIMITS			FINES
									LIQUID LIMIT	PLASTIC LIMIT	PLASTICITY INDEX	
0												
0.4		BITUMINOUS PAVEMENT (5 Inches)	881.1	AU								
0.9		APPARENT AGGREGATE BASE (6 Inches)	880.6									
1.5		SILTY SAND, (SM) dark brown, fine to medium grained, moist, trace gravel <b>(Undocumented Fill)</b>	880.0	SS 1	67	5-8-7 (15)						
		POORLY GRADED SAND WITH SILT, (SP-SM) brown, fine to medium grained, moist, medium dense to loose, trace gravel (Alluvial)		SS 2	100	3-6-6 (12)						
5				SS 3	89	5-5-4 (9)						
				SS 4	100	3-3-3 (6)						
10				SS 5	89	3-3-3 (6)						
10.5			871.0									

Bottom of borehole at 10.5 feet.



**Inver Grove Heights**  
 6160 Carmen Avenue East  
 Inver Grove Heights, MN, 55076  
 P: 651-389-4191

**BORING NUMBER SB-6**

**CLIENT** City of Ramsey **PROJECT NAME** Brookview Estates Street Reconstructions  
**PROJECT NUMBER** 18.MS06855.000 **PROJECT LOCATION** Ramsey, MN  
**DATE STARTED** 9/26/18 **COMPLETED** 9/26/18 **GROUND ELEVATION** 883.5 feet **HOLE SIZE** 6 1/2 in.  
**DRILLING CONTRACTOR** NTI **GROUND WATER LEVELS:**  
**DRILLING METHOD** 3 1/4 in H.S.A **AT TIME OF DRILLING** --- No Groundwater Observed.  
**LOGGED BY** RRH **CHECKED BY** SDG **AT END OF DRILLING** ---  
**CAVE IN (ft)** --- **FROST DEPTH (ft)** --- **AFTER DRILLING** ---  
**NOTES** Elevation determined using a Trimble GeoXH 6000(NAVD 88 GeoID 09 datum).

NTI LOG - GENERAL (USE THIS ONE) - NTI-2017-09-14.GDT - 10/4/18 10:51 - R:RAMSEY\Y1-PROJECT\SB\BROOKVIEW ESTATES & STREET RECON\_GEO\_18.MSP\_06855.000\TESTING REPORT\SGINT\BROOKVIEW ESTATES.GPJ

DEPTH (ft)	GRAPHIC LOG	MATERIAL DESCRIPTION	SAMPLE TYPE NUMBER	RECOVERY % (RQD)	BLOW COUNTS (N VALUE)	POCKET PEN. (tsf)	DRY UNIT WT. (pcf)	MOISTURE CONTENT (%)	ATTERBERG LIMITS			FINES
									LIQUID LIMIT	PLASTIC LIMIT	PLASTICITY INDEX	
0												
0.4		BITUMINOUS PAVEMENT (5 Inches)	883.1	AU								
0.9		APPARENT AGGREGATE BASE (6 1/4 Inches)	882.6									
1.5		SILTY SAND, (SM) dark brown, fine to medium grained, moist, trace gravel <b>(Undocumented Fill)</b>	882.0	SS 1	89	5-6-5 (11)						
		SILTY SAND, (SM) brown, fine to medium grained, moist, medium dense, trace gravel (Alluvial)		SS 2	100	3-5-5 (10)						
4.0			879.5									
		POORLY GRADED SAND WITH SILT, (SP-SM) brown to light brown, fine to medium grained, moist, loose, trace gravel (Alluvial)		SS 3	89	3-4-3 (7)						
				SS 4	67	3-3-3 (6)						
10				SS 5	100	3-3-3 (6)						
10.5			873.0									

Bottom of borehole at 10.5 feet.



**Inver Grove Heights**  
 6160 Carmen Avenue East  
 Inver Grove Heights, MN, 55076  
 P: 651-389-4191

**BORING NUMBER SB-7**

**CLIENT** City of Ramsey **PROJECT NAME** Brookview Estates Street Reconstructions  
**PROJECT NUMBER** 18.MS06855.000 **PROJECT LOCATION** Ramsey, MN  
**DATE STARTED** 9/26/18 **COMPLETED** 9/26/18 **GROUND ELEVATION** 882 feet **HOLE SIZE** 6 1/2 in.  
**DRILLING CONTRACTOR** NTI **GROUND WATER LEVELS:**  
**DRILLING METHOD** 3 1/4 in H.S.A **AT TIME OF DRILLING** --- No Groundwater Observed.  
**LOGGED BY** RRH **CHECKED BY** SDG **AT END OF DRILLING** ---  
**CAVE IN (ft)** --- **FROST DEPTH (ft)** --- **AFTER DRILLING** ---  
**NOTES** Elevation determined using a Trimble GeoXH 6000(NAVD 88 GeoID 09 datum).

NTI LOG - GENERAL (USE THIS ONE) - NTI-2017-09-14.GDT - 10/4/18 10:51 - R:RAMSEY\Y1-PROJECT\SB\BROOKVIEW ESTATES & STREET RECON\_GEO\_18.MSP\_06855.000\TESTING\REPORTS\BROOKVIEW ESTATES.GPJ

DEPTH (ft)	GRAPHIC LOG	MATERIAL DESCRIPTION	SAMPLE TYPE NUMBER	RECOVERY % (RQD)	BLOW COUNTS (N VALUE)	POCKET PEN. (tsf)	DRY UNIT WT. (pcf)	MOISTURE CONTENT (%)	ATTERBERG LIMITS			FINES
									LIQUID LIMIT	PLASTIC LIMIT	PLASTICITY INDEX	
0												
0.4		BITUMINOUS PAVEMENT (4 1/4 Inches)	AU									
0.9		APPARENT AGGREGATE BASE (6 Inches)										
		SILTY SAND, (SM) dark brown, fine to medium grained, moist, trace gravel <b>(Undocumented Fill)</b>	SS 1	100	5-6-7 (13)			8				
			SS 2	67	5-5-5 (10)							
4.0												
5		SANDY LEAN CLAY, (CL) brown, moist, medium, trace gravel (Alluvial)	SS 3	89	2-2-3 (5)			21				
6.5												
		POORLY GRADED SAND WITH SILT, (SP-SM) brown, fine to medium grained, moist, medium dense, trace gravel (Alluvial)	SS 4	100	3-3-3 (6)							
10												
			SS 5	100	6-6-7 (13)							
10.5												

Bottom of borehole at 10.5 feet.

Petition for (fill in the blank)

# 19-02 BROOKVIEW ESTATES  
RECONSTRUCTIONS.

Date 12-10-18

SEE ATTACHED

Opposition Statement ("We, the residents of Brookview Estates, are opposed to...") LETTER

JK  
AR  
SP  
DW  
LH  
CO  
R  
DJ  
SFB  
SJK  
MR  
W  
DYM  
LH

No.	Print Name	Signature	Address	Phone/Email
1	[REDACTED]	[REDACTED]	17230 GERMANIUM ST NW	[REDACTED]
2	[REDACTED]	[REDACTED]	57 NW - 17290 GERMANIUM ST NW	[REDACTED]
3	[REDACTED]	[REDACTED]	5530 173rd Ave NW	[REDACTED]
4	[REDACTED]	[REDACTED]	5450 173 Ave NW	[REDACTED]
5	[REDACTED]	[REDACTED]	5410 173rd Ave NW	[REDACTED]
6	[REDACTED]	[REDACTED]	5420 -173 <sup>rd</sup> Ave NW	[REDACTED]
7	[REDACTED]	[REDACTED]	17200 Germanium	[REDACTED]
8	[REDACTED]	[REDACTED]	17331 Germanium	[REDACTED]
9	[REDACTED]	[REDACTED]	17330 Germanium	[REDACTED]
10	[REDACTED]	[REDACTED]	5451-173rd Ave NW	[REDACTED]
11	[REDACTED]	[REDACTED]	17311 Germanium St	[REDACTED]
12	[REDACTED]	[REDACTED]	17228 Germanium St	[REDACTED]
13	[REDACTED]	[REDACTED]	5401 173 <sup>rd</sup> Ave NW	[REDACTED]
14	[REDACTED]	[REDACTED]	17310 GERMANIUM ST NW	[REDACTED]
15	[REDACTED]	[REDACTED]	5431 173 <sup>rd</sup> Ave	[REDACTED]

Kurt Ulrich, ICMA-CM  
City Administrator  
763.433.9845 Direct  
612.597.6838 Cell  
kulrich@cityoframsey.com

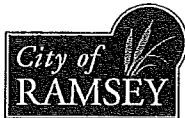

7550 Sunwood Drive NW  
Ramsey, MN 55303  
763.427.1410 City Hall  
763.433.9898 Fax  
www.cityoframsey.com

Received

PETITION

12/10/18

K6W Co

BROOK VIEW ESTATES RECONSTRUCTIONS  
PROJECT #19-02

WE OBJECT TO THIS IMPROVEMENT PROJECT  
#19-02 BECAUSE OF THE COST.

WE FEEL THAT THE IMPROVEMENT  
FOR DRAINAGE FOR THESE STREETS  
IS INAPPROPRIATE.

MOST OF HAVE LIVED HERE FOR 20+  
YEARS AND HAVE NOT HAD DRAINAGE  
ISSUES.

THE STREET NEEDS REPAIR NOT  
TOTAL RECONSTRUCTION IN  
OUR OPINION.

**Public Works Committee**

5. 2.

**Meeting Date:** 12/18/2018

**By:** Bruce Westby, Engineering/Public Works

---

**Title:**

Consider Request to Modify Traffic Control at Bunker Lake Boulevard, Puma Street and Rabbit Street Intersection.

**Purpose/Background:**

**Purpose/Background:**

During the November 27<sup>th</sup> City Council meeting, a resident living at 14942 Quintana Street NW in the Riverstone residential development questioned the value of the all-way STOP intersection control recently installed at the intersection of Bunker Lake Boulevard, Puma Street and Rabbit Street, and requested that the City consider modifying the traffic control at this intersection.

The resident told Council he feels the all-way STOP is unnecessary at this time and recommended that all of the STOP signs be removed and replaced with a YIELD sign on southbound Puma Street. He said he also felt that said a flasher signal might be appropriate for the pedestrian crossing at the intersection. He then stated that during the five-months he has lived in Riverstone he has never met another car at this intersection, nor has he ever seen a pedestrian or bicyclist use the crosswalk. He also stated he often sees Riverstone residents running the STOP signs and is concerned people will get used to running the STOP signs and will continue to do so once the area more fully develops and the STOP signs are warranted.

A copy of the City Council meeting minutes, which includes a more complete record of the property owner's comments, is attached for reference.

Staff plans to provide historical crash data for this intersection during the meeting.

Posted/statutory speed limits on each leg of the intersection are as follows:

- Bunker Lane Boulevard = 40 MPH
- Puma Street = 40 MPH
- Rabbit Street = 30 MPH

Traffic volumes were most recently recorded on each leg of the intersection in 2015 as follows:

- Bunker Lane Boulevard = 125 ADT
- Puma Street = 150 ADT
- Rabbit Street = Constructed 2017/2018

**Timeframe:**

Staff estimates 10 minutes will be needed for presentation and discussion.

**Observations/Alternatives:**

**Observations/Alternatives:**

Staff discussed the property owners concerns with Bolton & Menk, the design engineer for Improvement Project #18-05 under which the STOP signs were installed. Bolton & Menk stated that the all-way STOP control was based on the best information available at the time related to intersection geometrics and traffic volumes in and around the intersection at the time it opened.

Throughout the plan preparation process, Rabbit Street was still considered a future street and in order to obtain

State Aid approvals, STOP signs were required on both Bunker Lake Boulevard and Puma Street. Development timing and the resultant traffic growth were unknown at the time plans were developed, and traffic forecasts were aggressive. Growth in the area will dictate when an all-way STOP control is warranted.

In summary, traffic control is designed before construction is complete and is therefore theoretical in nature, based on anticipated conditions. If changes are made to traffic control after construction, the changes must account for actual conditions, which requires further study.

Bolton & Menk prepared the attached memo, which describes all this in more detail. The memo also recommends completing an updated traffic study to determine appropriate short and long-term traffic control options. Bolton & Menk can complete this study in January at a cost not-to-exceed \$3,000.

**Funding Source:**

The cost to remove a STOP sign is approximately \$200 per sign. The cost for City Staff to fabricate and install a new sign is approximately \$300 per sign. Staff proposes to pay for all costs to study and/or modify the traffic control at this intersection as part of City Improvement Project #18-05.

**Recommendation:**

Staff recommends completing the traffic study proposed by Bolton & Menk in January of 2019, and to present the findings to the Public Works Committee in February of 2019 for further discussion and direction.

**Action:**

Based on Committee direction. Actions will be communicated to the property owner at 14942 Quintana Street NW.

---

**Attachments**

BMI Memo

IP1805 SS Plans

---

**Form Review**

<b>Inbox</b>	<b>Reviewed By</b>	<b>Date</b>
Grant Riemer	Grant Riemer	12/13/2018 01:34 PM
Kurt Ulrich	Kurt Ulrich	12/13/2018 03:50 PM
Form Started By: Bruce Westby		Started On: 12/11/2018 10:31 AM
Final Approval Date: 12/13/2018		



Real People. Real Solutions.

7533 Sunwood Drive NW  
Suite 206  
Ramsey, MN 55303-5119

Ph: (763) 433-2851  
Fax: (763) 427-0833  
Bolton-Menk.com

## MEMORANDUM

**Date:** December 5, 2018  
**To:** Bruce Westby, P.E.  
**From:** Kevin Kielb, P.E.  
Bryan Nemeth, P.E.  
**Subject:** Bunker Lake Boulevard and Puma Street Intersection Control

At the request of the City, we are providing information related to the intersection traffic control at Bunker Lake Boulevard and Puma Street. The intersection control installed with the recent street reconstruction project includes an All Way STOP.

### INITIAL INSTALLATION

Bunker Lake Boulevard and Puma Street are State Aid routes. During the plan approval process, these were the only legs of the intersection constructed, with Rabbit Street depicted as a “future roadway”. Because the travel path from Bunker Lake Boulevard to Puma Street doesn’t meet a 30 MPH design speed, STOP signs were required to be placed on these two intersection legs. A third STOP sign was depicted on the plans for Rabbit Street to complete the All Way STOP.

### BACKGROUND

The Bunker Lake Boulevard and Puma Street intersection was one of the intersections reviewed as a portion of the Business Park Analysis. In the March 2017 Business Park Report Update, two types of control were reviewed for the intersection:

- Roundabout, and
- All Way STOP.

Both were found to be adequate for the anticipated short-term traffic volumes and long-term growth in the corridor.

### TRAFFIC PATTERNS VS SAFETY

The primary traffic in this area will be along Bunker Lake Boulevard and Puma Street, with lesser traffic on Rabbit Street. Because of the intersection configuration, the primary traffic patterns end up being secondary to safety concerns. This is addressed in the MUTCD, 2B.4 Right-of-Way at Intersections.

YIELD or STOP signs should be used at an intersection if one or more of the following conditions exist:

- A. An intersection of a less important road with a main road where application of the normal right-of-way rule would not be expected to provide reasonable compliance with the law.

It is not recommended, due to safety considerations, that Rabbit Street be STOP or YIELD controlled and Bunker Lake Boulevard and Puma Street be uncontrolled. If neither Bunker Lake Boulevard or Puma Street had either STOP signs or YIELD signs, both the westbound vehicle and the southbound left/right turning vehicles would technically have the right-of-way. Each could proceed with their movement, and meet in the intersection.

### **INTERSECTION CONTROL PROGRESSION**

For the 2040 traffic volumes, either a roundabout or an All Way STOP provide high Levels of Service for the intersection.

There is the potential for interim intersection traffic control to be implemented based on actual site and traffic characteristics. If adjustments were made, the progression would most likely be:

- YIELD sign for southbound Puma Street,
- Then STOP sign for southbound Puma Street, and
- Then All Way STOP at the intersection.

### **INTERSECTION ANALYSIS**

The existing intersection control was selected based upon several factors, including: State Aid requirements, traffic forecasts, safety and anticipated traffic patterns. The selection was based on a traffic study that was completed prior to the reconstruction of Bunker Lake Boulevard and Puma Street and prior to the construction of Rabbit Street.

If the City is considering adjustments, the following guidance from the MUTCD should be considered when preparing an updated traffic study based upon the actual improved site conditions:

Engineering judgment should be used to establish inter-section control. The following factors should be considered:

- A. Vehicular, bicycle, and pedestrian traffic volumes on all approaches;
- B. Number and angle of approaches;
- C. Approach speeds;
- D. Sight distance available on each approach; and
- E. Reported crash experience.



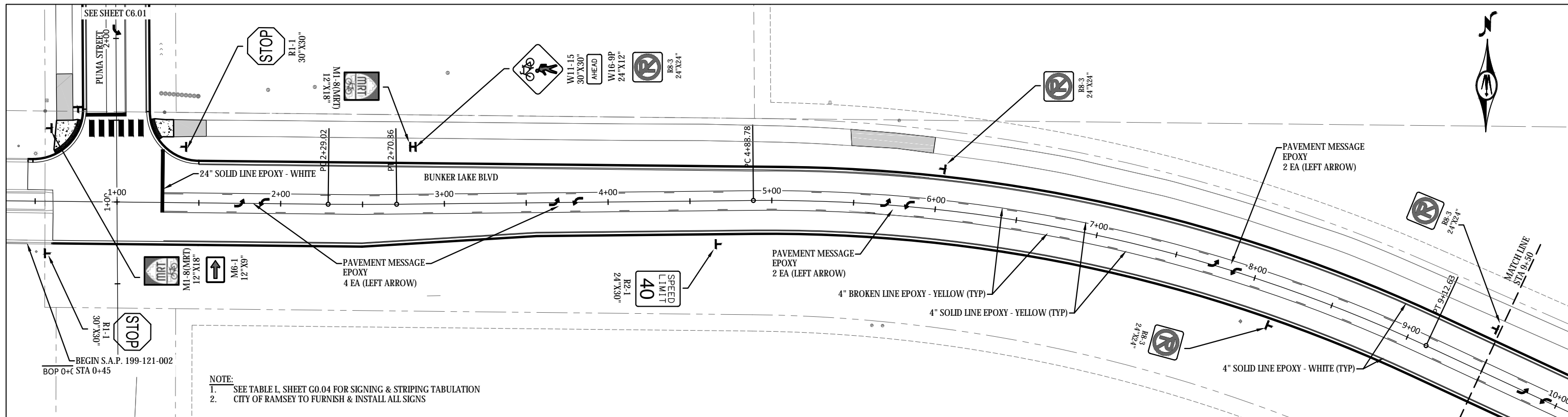

NOTE:  
 1. SEE TABLE L, SHEET G0.04 FOR SIGNING & STRIPING TABULATION  
 2. CITY OF RAMSEY TO FURNISH & INSTALL ALL SIGNS

SIGN LEGEND	SIGN NUMBER & SIZE	NOTES	ESTIMATED QUANTITY	SIGN LEGEND	SIGN NUMBER & SIZE	NOTES	ESTIMATED QUANTITY	SIGN LEGEND	SIGN NUMBER & SIZE	NOTES	ESTIMATED QUANTITY	SIGN LEGEND	SIGN NUMBER & SIZE	NOTES	ESTIMATED QUANTITY	SIGN LEGEND	SIGN NUMBER & SIZE	NOTES	ESTIMATED QUANTITY
	R1-1 30"X30"		2		W1-7 48"X24"		1		M1-8(MRT) 12"X18"		2		W1-2L 30"X30"		1		R3-9cP 24"X8"	INSTALL R3-9cP & R3-9dP SIGNS ON SAME POST AS R3-9b	1
	W11-15 30"X30"		1		R2-1 24"X30"		1		M6-1 12"X9"	INSTALL M6-1 SIGN ON SAME POST AS M1-8 (MRT)	1		W13-1P 18"X18"	INSTALL W13-1P SIGN ON SAME POST AS W1-2L	1		R3-9dP 24"X8"		1
	W16-9P 24"X12"		1						R3-3 24"X24"		6						R3-9b 24"X36"		2

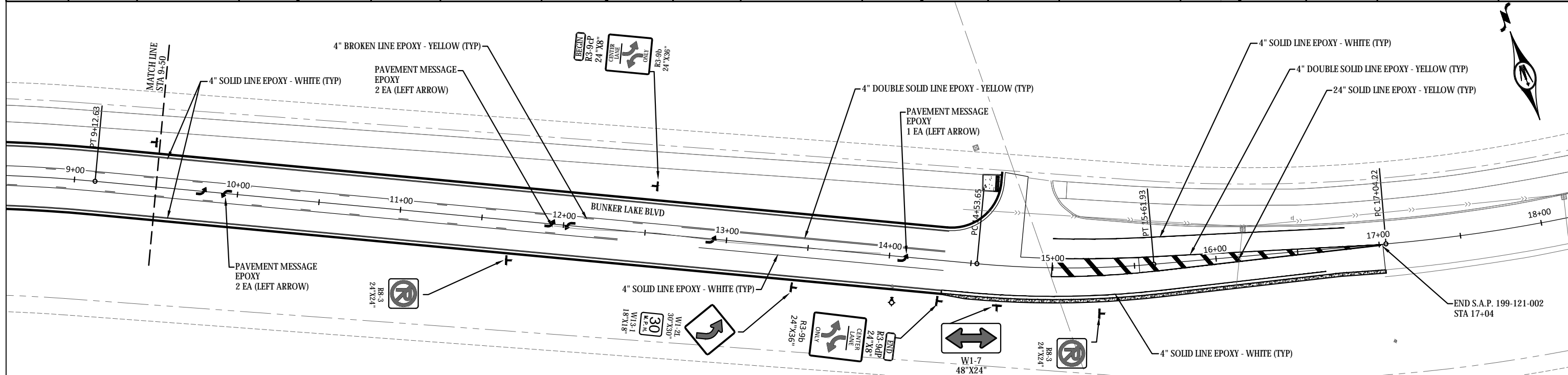

	7533 SUNWOOD DR NW, SUITE 206 RAMSEY, MINNESOTA 55303 Phone: (763) 433-2851 Email: Ramsey@bolton-menk.com www.bolton-menk.com	REV: _____ ISSUED FOR: _____ DATE: _____	I HEREBY CERTIFY THAT THIS PLAN, SPECIFICATION, OR REPORT WAS PREPARED BY ME OR UNDER MY DIRECT SUPERVISION AND THAT I AM A DULY LICENSED PROFESSIONAL ENGINEER UNDER THE LAWS OF THE STATE OF MINNESOTA.  KEVIN P. KIEL LIC. NO. 23211 DATE 04/12/2018	DESIGNED: JWC DRAWN: EKD CHECKED: KPK	<b>CITY OF RAMSEY, MINNESOTA</b> BUNKER LAKE BOULEVARD AND PUMA STREET IMPROVEMENTS S.A.P. 199-109-006, S.A.P. 199-121-002 <b>SIGNING &amp; STRIPING PLAN</b>	SHEET <b>C6.02</b>
		© Bolton & Menk, Inc. 2018. All Rights Reserved H:\RAMS\R16114473\CAD\114473C601A.dwg 4/26/2018 11:01 AM				

**Public Works Committee**

**5.3.**

**Meeting Date:** 12/18/2018

**Submitted For:** Grant Riemer, Engineering/Public Works

**By:** Grant Riemer, Engineering/Public Works

---

**Title:**

**Highway 47 Landscaping Project**

**Purpose/Background:**

The purpose of this project is to partner with MnDOT to improve the landscaping along Hwy 47 from roughly Xkimo St to the south and Barium St to the north. The project falls under MnDOT's Community Roadside Landscape Partnership Program. MnDOT's Office of [Environmental Stewardship](#) provides technical and financial support to communities to install and maintain landscape plantings on eligible state highway rights of way. MnDOT would partner with the city of Ramsey by providing the services of their landscape architect to design the landscaping for the project and also provide financial assistance to buy plant materials. The city of Ramsey would provide the manpower to install the plantings and would also be responsible for on going maintenance, such as weeding of the plant beds and watering.

**Timeframe:**

10 Minutes

**Observations/Alternatives:**

This project would touch on several areas of our strategic plan.

**Strategic Imperative III: Smart, Citizen-Focused Government**

- 20) Improve the image of residential neighborhoods, business districts, and key corridors
- 22) Clean Up areas of blight along Highway 47/Saint Francis Blvd
- 24) Identify opportunities for community volunteer work and citizen recognition.

MnDOT has provided a design plan for the project and that plan is attached to this case. The next step in the process is to pass a resolution stating that the City of Ramsey is willing to enter into a cooperative agreement with MnDOT to execute the project. A draft copy of that resolution is attached to this case.

**Funding Source:**

Ongoing maintenance duties for the project would be covered under normal PW duties. Plant materials and design would be part of MnDOT's partnership program assistance.

**Recommendation:**

Staff recommends approving **RESOLUTION #18-XXX** stating that the City of Ramsey is willing to enter into a cooperative agreement with MnDOT to execute the Hwy 47 landscape project SP0206-969A (TH 47 Sound wall)

**Action:**

Approve staff recommendation and forward **RESOLUTION #18-XXX** to the full council for consideration or deny staff recommendation and approve alternate recommendation based on committee discussion.

---

**Attachments**

Resolution # 18-XXX

**Form Review**

**Inbox**

Kurt Ulrich

Form Started By: Grant Riemer

Final Approval Date: 12/13/2018

**Reviewed By**

Kurt Ulrich

**Date**

12/13/2018 03:57 PM

Started On: 12/13/2018 08:39 AM

Councilmember introduced the following resolution and moved for its adoption:

**RESOLUTION #18-XXX**

**RESOLUTION ENTERING INTO COOPERATIVE AGREEMENT WITH MNDOT FOR STATE TRUNK HIGHWAY 47 SOUNDWALL LANDSCAPE IMPROVEMENTS**

**WHEREAS**, the City of Ramsey and Minnesota Department of Transportation enter into a cooperative agreement for landscape improvements along the sound wall on Trunk Highway 47.

**NOW THEREFORE, BE IT RESOLVED BY THE CITY COUNCIL OF THE CITY OF RAMSEY, ANOKA COUNTY, STATE OF MINNESOTA:**

- 1) The City Council act as sponsoring unit for the project identified as SP0206-969A (TH 47 Sound wall) on the State Trunk Highway 47 during the period \_\_\_\_\_ through \_\_\_\_\_.
- 2) Grant Riemer, Public Works Superintendent is hereby authorized to apply to the Minnesota Department of Transportation for funding of this project on behalf of City of Ramsey.

The motion for adoption of the foregoing resolution was duly seconded by Councilmember, and upon vote being taken thereon, the following voted in favor thereof:

and the following voted against the same:

and the following abstained:

and the following were absent:

Whereupon said resolution was declared duly passed and adopted by the Ramsey City Council this XXth day of XXX, 20XX.

\_\_\_\_\_  
Mayor

ATTEST:

\_\_\_\_\_  
City Clerk

# MINNESOTA DEPARTMENT OF TRANSPORTATION

## CONSTRUCTION PLAN FOR LANDSCAPING

LOCATED ON T.H.47 FROM APPROX. 900 FT NORTH OF NOWTHEN BLVD NW TO APPROX. 180 FT NORTH OF BARIUM STREET NW IN RAMSEY

STATE PROJ. NO. 0206-969A  
 MINN. PROJ. NO. \_\_\_\_\_  
 GROSS LENGTH \_\_\_\_\_ FEET \_\_\_\_\_ MILES  
 BRIDGES-LENGTH \_\_\_\_\_ FEET \_\_\_\_\_ MILES  
 EXCEPTIONS-LENGTH \_\_\_\_\_ FEET \_\_\_\_\_ MILES  
 NET LENGTH \_\_\_\_\_ FEET \_\_\_\_\_ MILES  
 REF. POINT 22+0.863 TO REF. POINT 23+0.675

FED. PROJ. NO. \_\_\_\_\_ STATE FUNDS

GOVERNING SPECIFICATIONS  
 THE 2018 EDITION OF THE MINNESOTA DEPARTMENT OF TRANSPORTATION  
 "STANDARD SPECIFICATIONS FOR CONSTRUCTION" SHALL GOVERN.

### INDEX

TITLE SHEET	1
GENERAL LAYOUT	2
ESTIMATED QUANTITIES	3
PLANT STOCK TABULATIONS	4
LANDSCAPE PLAN	5-12
STANDARD PLANTING DETAILS (A-C)	13-15

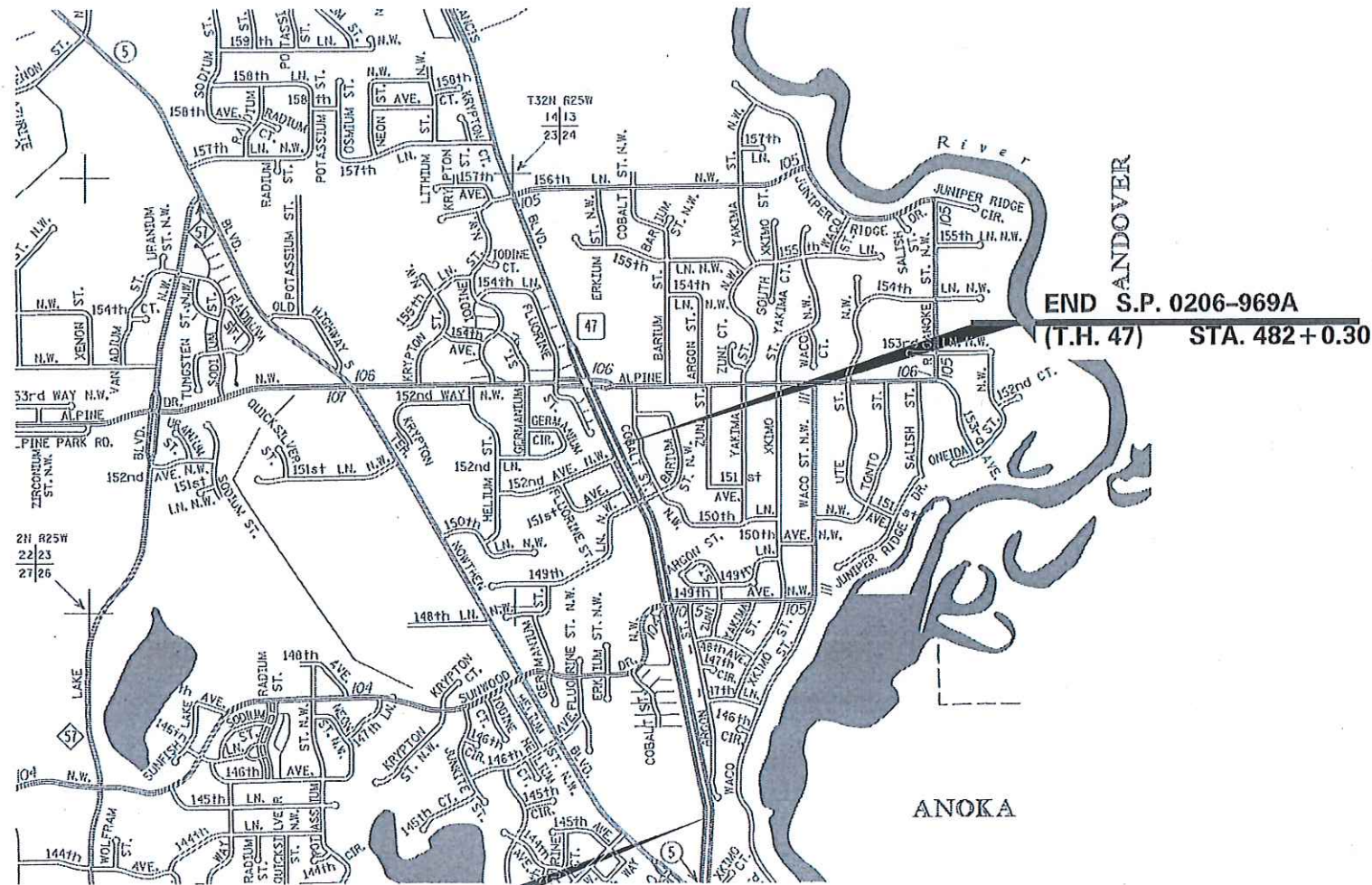

END S.P. 0206-969A  
 (T.H. 47) STA. 482+0.30

BEGIN S.P. 0206-969A  
 (T.H. 47) STA. 440+0.50

THIS PLAN CONTAINS 15 SHEETS

I HEREBY CERTIFY THAT THIS PLAN WAS PREPARED BY ME OR UNDER MY DIRECT SUPERVISION AND THAT I AM A DULY LICENSED PROFESSIONAL LANDSCAPE ARCHITECT UNDER THE LAWS OF THE STATE OF MINNESOTA.

DATE 10/31/13 LIC. NO. 26551 LA [Signature]  
 PROJECT L.A. Todd Carroll, LANDSCAPE ARCHITECT  
 PROJECT DESIGNERS PHILIP ZENGE  
 RECOMMENDED FOR APPROVAL BY: [Signature] 11/31/2013 LANDSCAPE PARTNERSHIP COORDINATOR  
 RECOMMENDED FOR APPROVAL BY: [Signature] 11/27/15 DISTRICT LANDSCAPE PARTNERSHIP COORDINATOR  
 APPROVED \_\_\_\_\_ 20 \_\_\_\_\_ 11/27/18 DISTRICT ENGINEER

FOR PLANS & UTILITIES SYMBOLS SEE TECHNICAL MANUAL

PROJ. NO. 0206-969A CHARGE IDENTIFIER \_\_\_\_\_  
 \_\_\_\_\_  
 \_\_\_\_\_

I HEREBY CERTIFY THAT THE FINAL FIELD REVISIONS, IF ANY, OF THIS PLAN WERE MADE BY ME OR UNDER MY DIRECT SUPERVISION AND THAT I AM A DULY LICENSED PROFESSIONAL ENGINEER UNDER THE LAWS OF THE STATE OF MINNESOTA.

PRINT NAME: \_\_\_\_\_ LIC. NO.: \_\_\_\_\_  
 DATE: \_\_\_\_\_ SIGNATURE: \_\_\_\_\_

PLAN REVISIONS		
DATE	SHEET NO.	APPROVED BY

DESIGN DESIGNATION - TIER NO. \_\_\_\_\_

PROJECT LOCATION  
 COUNTY: ANOKA  
 DISTRICT: METRO

DATE PRINTED: 10/31/2018  
 TIME PRINTED: 8:08:53 AM

INDEX MAP NO SCALE  
 GENERAL LAYOUT 0 500 IN  
 PLAN 0 50 FEET

ADT (Current Year) 23,000 = 2017  
 Design Speed 55 MPH

OFFICE OF ENVIRONMENTAL STEWARDSHIP  
 ENV. PLANNING AND DESIGN UNIT  
 DEPARTMENT OF TRANSPORTATION BUILDING  
 ST. PAUL, MINNESOTA 55155-1899

TITLE SHEET  
 STATE PROJECT 0206-969A (T.H. 47 = 110) SHEET NO. 1 OF 15 SHEETS



500  
SCALE IN FEET

BEGIN S.P. 0206-969A  
(T.H. 47) STA. 440+0.50

END S.P. 0206-969A  
(T.H. 47) STA. 482+0.30

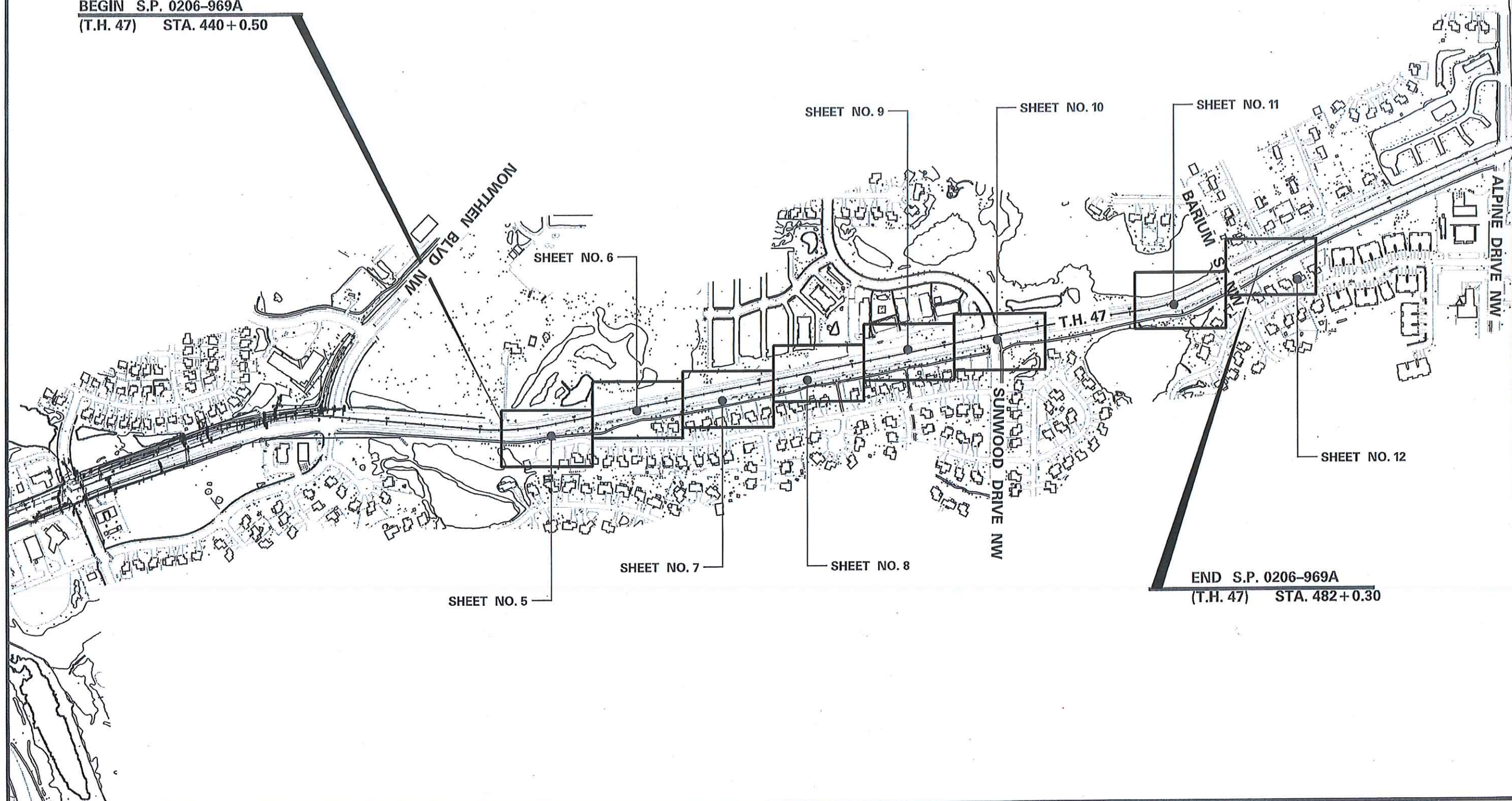

DATE PRINTED: 10/31/2018	TIME PRINTED: 8:08:55 AM	PROJECT MANAGER PHILIP ZENGE	DRAWN BY PHILIP ZENGE	DATE 01/15/01	LIC. NO. 26551	GENERAL LAYOUT	
		CHECKED BY DENNIS MOLINE	SIGNATURE 	 OFFICE OF ENVIRONMENTAL STEWARDSHIP ENV. PLANNING AND DESIGN UNIT TRANSPORTATION BUILDING ST. PAUL, MINNESOTA 55155-1899			
						STATE PROJECT 0206-969A (T.H. 47)	SHEET NO. 2 OF 15 SHEETS

**STATEMENT OF ESTIMATED QUANTITIES**

ITEM No.	DESCRIPTION	UNITS	ESTIMATED
			S.P.0206-969A
2571.524	ORNAMENTAL TREE 5' HT CONT	TREE	15
2571.525	DECIDUOUS SHRUB 12" HT CONT	SHRUB	357
2574.507	COMPOST GRADE 2	CU YD	125
2575.507	MULCH MATERIAL TYPE 6	CU YD	126

**UTILITY NOTES:**

- NO UTILITIES WILL BE AFFECTED BY THIS PROJECT.

**GENERAL NOTES:**

- LOCATE SHRUBS, A MINIMUM OF 5' FROM NOISE WALLS.
- COMPLETE ALL TILLING USING A SPADE TYPE TILLER.
- SEE THE PLANT STOCK TABULATION TABLE FOR INDIVIDUAL PLANT QUANTITIES.
- RESTORE ALL DAMAGED TURF TO PRE-LANDSCAPE INSTALLATION CONDITIONS.

DATE PRINTED:  
10/31/2018

TIME PRINTED:  
10:17:32 AM

PROJECT MANAGER  
PHILIP ZENGE

DRAWN BY  
PHILIP ZENGE

DATE 12/7/13 LIC. NO. 26551

SIGNATURE  LICENSED PROFESSIONAL LANDSCAPE ARCHITECT



OFFICE OF ENVIRONMENTAL STEWARDSHIP  
ENV. PLANNING AND DESIGN UNIT  
TRANSPORTATION BUILDING  
ST. PAUL, MINNESOTA 55155-1899

**ESTIMATED QUANTITIES**

STATE PROJECT 0206-969A (T.H. 47)

SHEET NO. 3 OF 15 SHEETS

PLANT STOCK TABULATION S.P. 0206-969A

KEY	SPECIES	Minimum Acceptable Dimensions	Units	TOTAL QUANTITY
	ORNAMENTAL TREE 5' HT CONT	5.5' Ht., No. 10 Cont.	TOTAL	15
ABS_5'	SERVICEBERRY, AUTUMN BRILLIANCE		TREE	15
	<i>Amelanchier x grandiflora (Autumn Brilliance)</i>			
	DECIDUOUS SHRUB 12" HT CONT	10.5" Ht., No. 2 Cont.	TOTAL	357
GBC_12"	CHOKEBERRY, GLOSSY BLACK		SHRUB	57
	<i>Aronia melanocarpa</i>			
CMN_12"	NINEBARK, COMMON		SHRUB	60
	<i>Physocarpus opulifolius</i>			
BWS_12"	SPIREA, BRIDALWREATH		SHRUB	56
	<i>Spiraea prunifolia</i>			
FGS_12"	SUMAC, FRAGRANT		SHRUB	60
	<i>Rhus aromatica</i>			
TES_12"	SUMAC, TIGER EYES		SHRUB	78
	<i>Rhus typhina (Bailtiger)</i>			
AWV_12"	VIBURNUM, ARROWWOOD		SHRUB	46
	<i>Viburnum dentatum</i>			
<b>TOTAL (Planting Material)</b>				<b>372</b>

DATE PRINTED:  
10/31/2018

TIME PRINTED:  
10:19:23 AM

PROJECT MANAGER  
PHILIP ZENGE

DRAWN BY  
PHILIP ZENGE

DATE 10/31/18 LIC. NO. 26551

SIGNATURE  LICENSED PROFESSIONAL LANDSCAPE ARCHITECT

CHECKED BY  
DENNIS MOLINE



OFFICE OF ENVIRONMENTAL STEWARDSHIP  
ENV. PLANNING AND DESIGN UNIT  
TRANSPORTATION BUILDING  
ST. PAUL, MINNESOTA 55155-1699

PLANT STOCK TABULATIONS

STATE PROJECT 0206-969A (T.H. 47)

SHEET NO. 4 OF 15 SHEETS

KEY	SPECIES	QUANT.	SPACING
ABS_5'	SERVICEBERRY, AUTUMN BRILLIANCE	3	AS SHOWN
CMN_12"	NINEBARK, COMMON	11	5' O.C.
BWS_12"	SPIREA, BRIDALWREATH	16	5' O.C.
FGS_12"	SUMAC, FRAGRANT	11	5' O.C.
TES_12"	SUMAC, TIGER EYES	20	6' O.C.

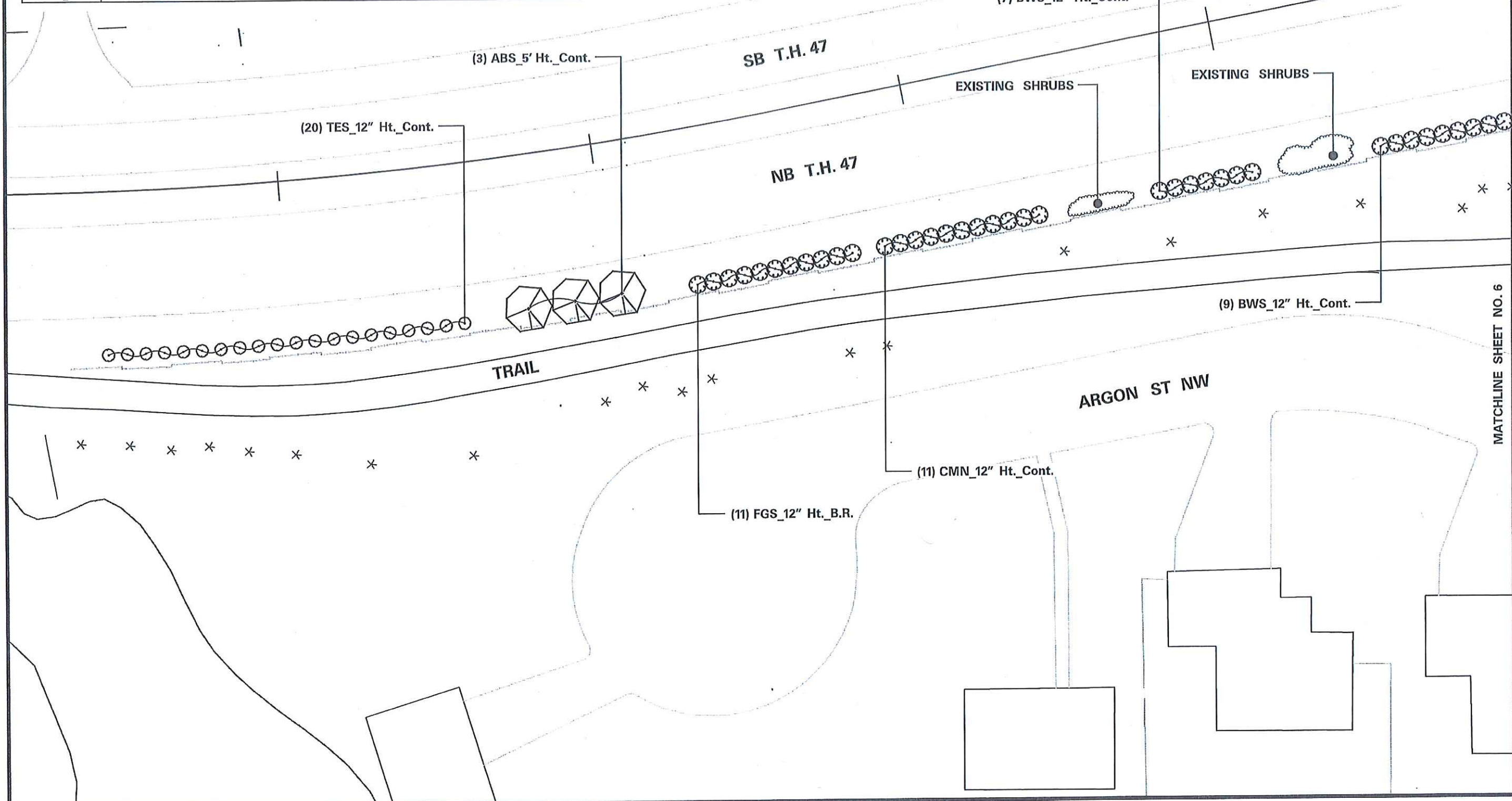
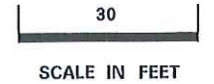

KEY	SPECIES	QUANT.	SPACING
ABS_5'	SERVICEBERRY, AUTUMN BRILLIANCE	3	AS SHOWN
GBC_12"	CHOKEBERRY, GLOSSY BLACK	11	5' O.C.
BWS_12"	SPIREA, BRIDALWREATH	11	5' O.C.
FGS_12"	SUMAC, FRAGRANT	8	5' O.C.
AWV_12"	VIBURNUMN, ARROWWOOD	20	5' O.C.

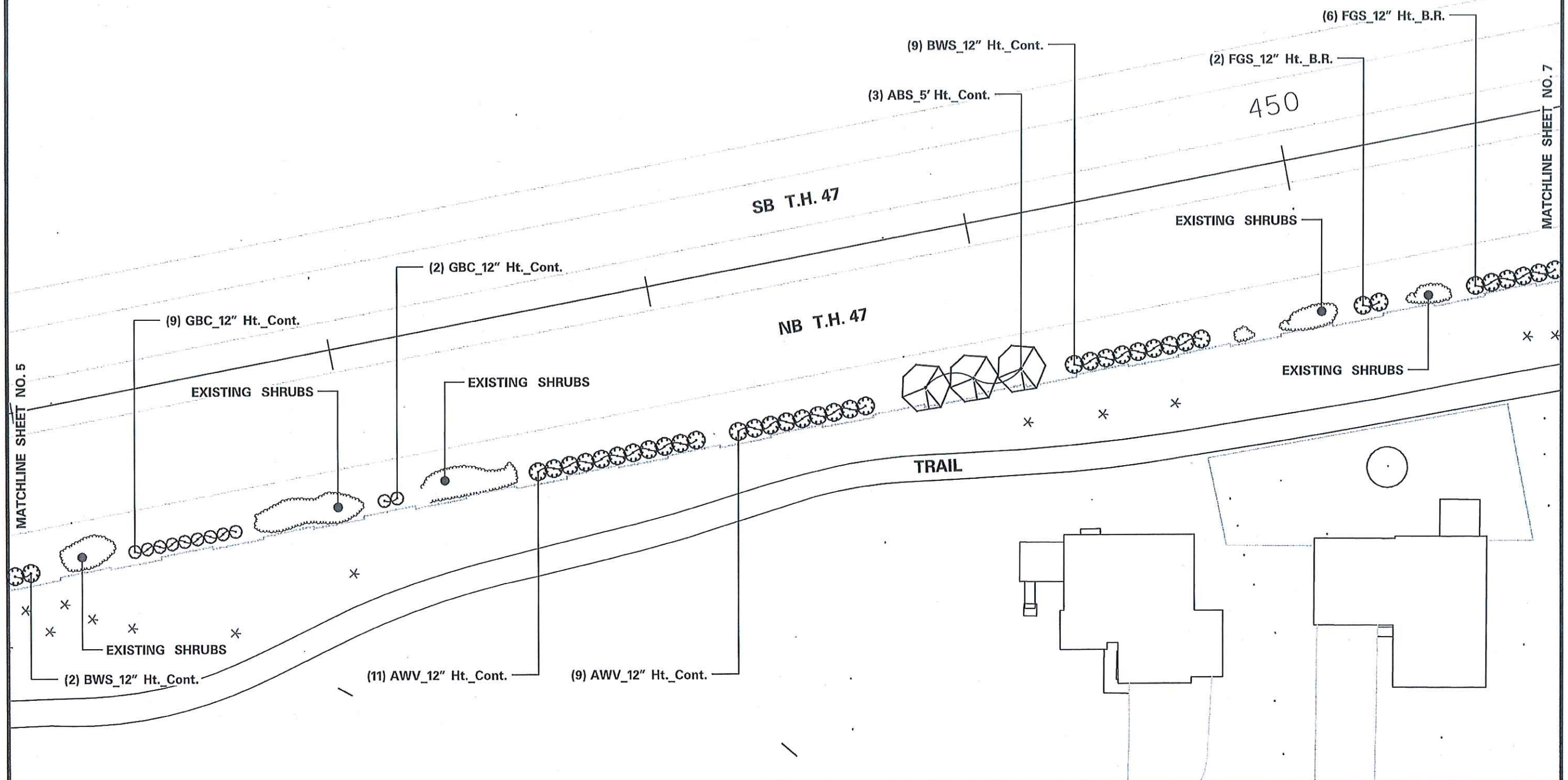

KEY	SPECIES	QUANT.	SPACING
ABS_5'	SERVICEBERRY, AUTUMN BRILLIANCE	3	AS SHOWN
CMN_12"	NINEBARK, COMMON	28	5' O.C.
FGS_12"	SUMAC, FRAGRANT	3	5' O.C.
TES_12"	SUMAC, TIGER EYES	15	6' O.C.
AWV_12"	VIBURNUM, ARROWWOOD	11	5' O.C.



30  
SCALE IN FEET

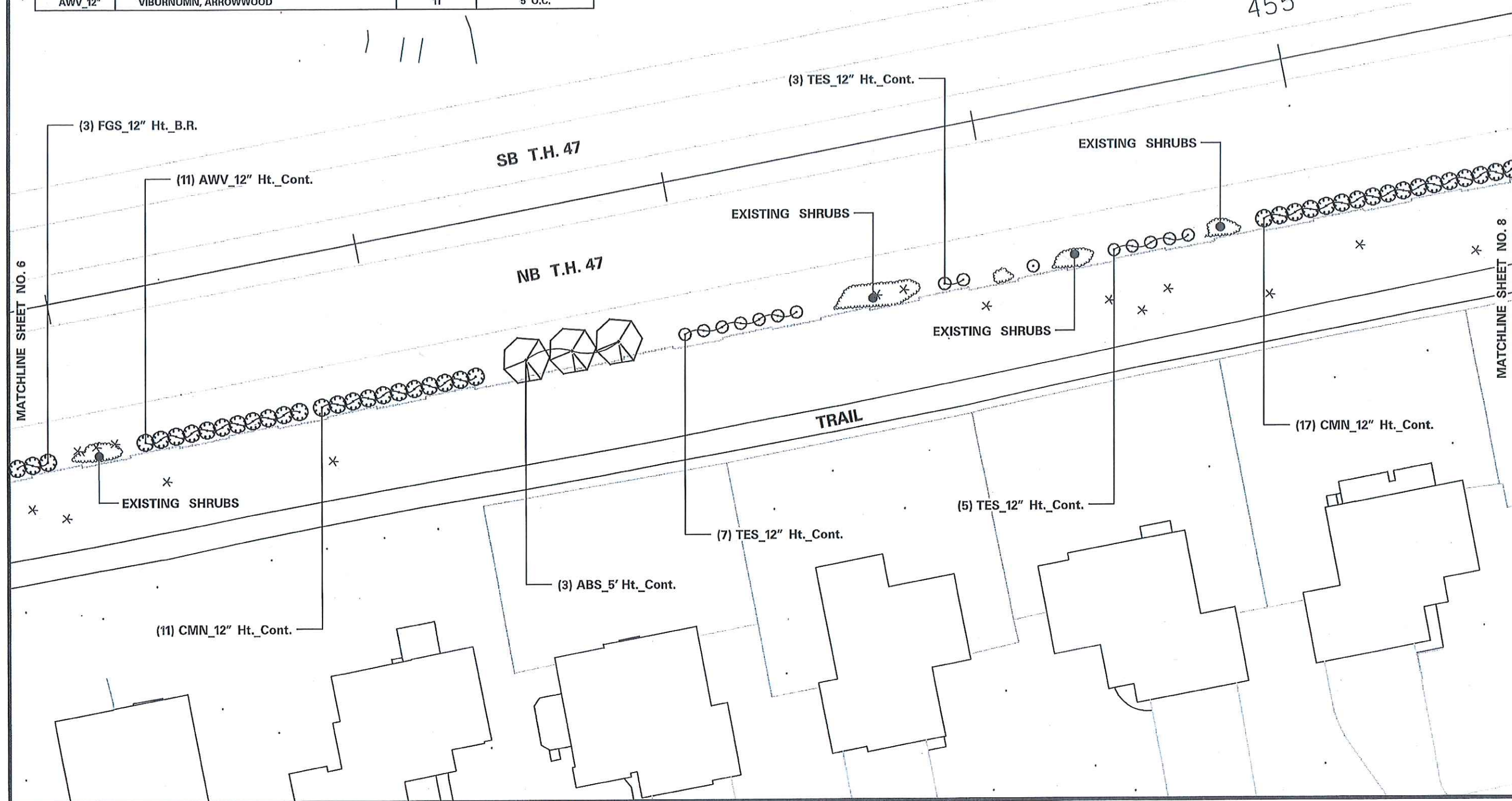

KEY	SPECIES	QUANT.	SPACING
ABS_5'	SERVICEBERRY, AUTUMN BRILLIANCE	3	AS SHOWN
GBC_12"	CHOKEBERRY, GLOSSY BLACK	17	5' O.C.
CMN_12"	NINEBARK, COMMON	4	5' O.C.
BWS_12"	SPIREA, BRIDALWREATH	17	5' O.C.
FGS_12"	SUMAC, FRAGRANT	19	5' O.C.
AWV_12"	VIBURNUMN, ARROWWOOD	13	5' O.C.

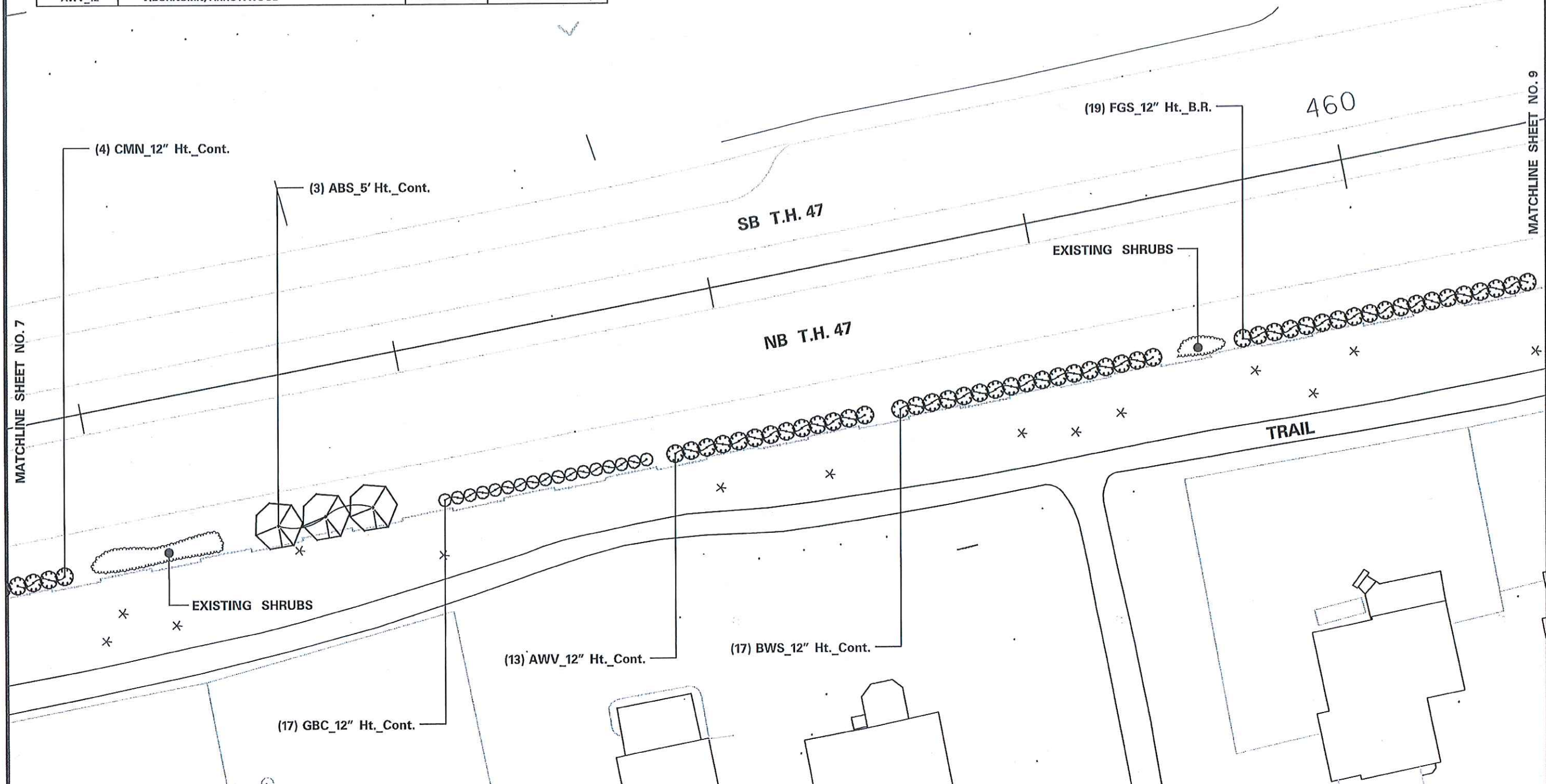
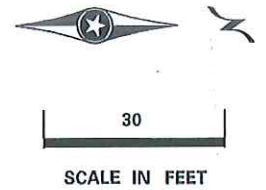

KEY	SPECIES	QUANT.	SPACING
ABS_5'	SERVICEBERRY, AUTUMN BRILLIANCE	3	AS SHOWN
CMN_12"	NINEBARK, COMMON	17	5' O.C.
BWS_12"	SPIREA, BRIDALWREATH	12	5' O.C.
FGS_12"	SUMAC, FRAGRANT	19	5' O.C.
AWV_12"	VIBURNUM, ARROWWOOD	13	5' O.C.



30  
SCALE IN FEET

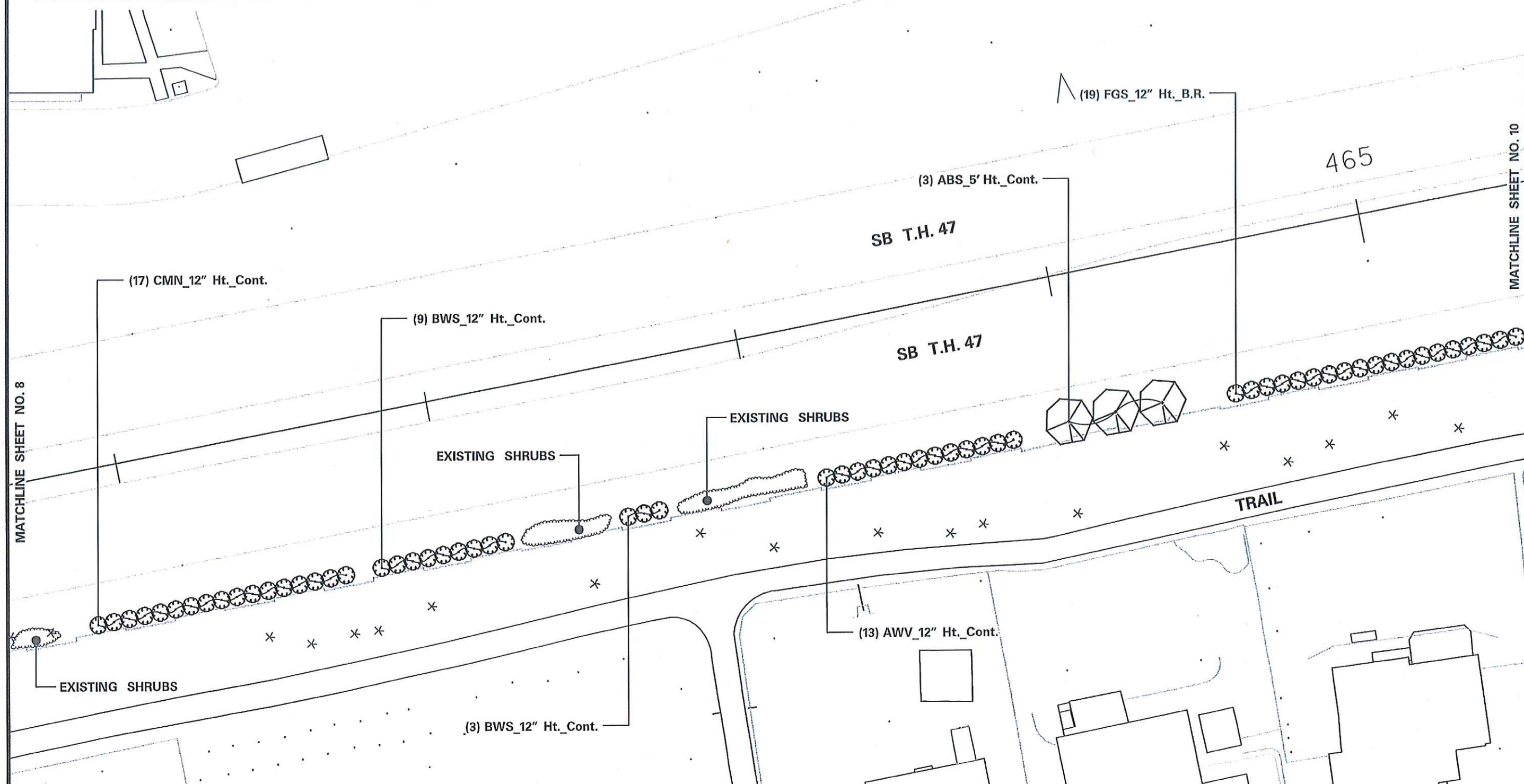

KEY	SPECIES	QUANT.	SPACING
TES_12"	SUMAC, TIGER EYES	21	6' O.C.



30

SCALE IN FEET

470

SB T.H. 47

NB T.H. 47

TRAIL

TRAIL

SUNWOOD DRIVE NW

(21) TES\_12" Ht. Cont.

MATCHLINE SHEET NO. 9

DATE PRINTED:  
10/31/2018

TIME PRINTED:  
8:09:11 AM

PROJECT MANAGER  
PHILIP ZENGE

DRAWN BY  
PHILIP ZENGE

DATE 10/31/18 LIC. NO. 26551

CHECKED BY  
DENNIS MOLINE

SIGNATURE  LICENSED PROFESSIONAL LANDSCAPE ARCHITECT



OFFICE OF ENVIRONMENTAL STEWARDSHIP  
ENV. PLANNING AND DESIGN UNIT  
TRANSPORTATION BUILDING  
ST. PAUL, MINNESOTA 55155-1899

LANDSCAPE PLAN

STATE PROJECT 0206-969A (T.H. 47)

SHEET NO. 10 OF 15 SHEETS

KEY	SPECIES	QUANT.	SPACING
TES_12"	SUMAC, TIGER EYES	22	6' O.C.



30  
SCALE IN FEET

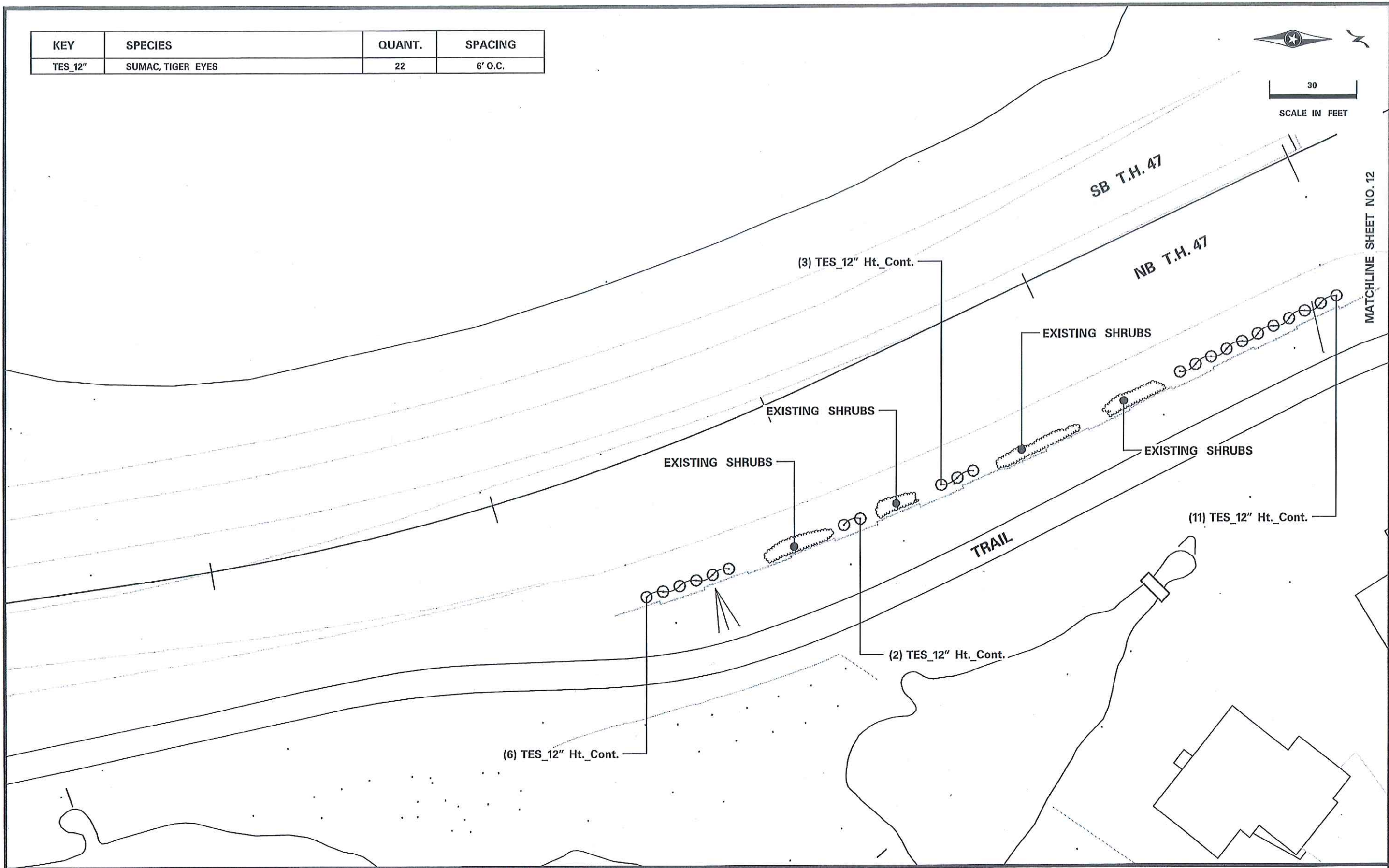

MATCHLINE SHEET NO. 12

DATE PRINTED:  
10/31/2018

TIME PRINTED:  
8:09:14 AM

PROJECT MANAGER  
PHILIP ZENGE

DRAWN BY  
PHILIP ZENGE  
  
CHECKED BY  
DENNIS MOLINE

DATE 10/31/18 LIC. NO. 26551  
SIGNATURE [Signature]  
LANDSCAPE ARCHITECT

**mm** OFFICE OF ENVIRONMENTAL STEWARDSHIP  
ENV. PLANNING AND DESIGN UNIT  
DEPARTMENT OF TRANSPORTATION BUILDING  
ST. PAUL, MINNESOTA 55155-1899

**LANDSCAPE PLAN**

STATE PROJECT 0206-969A (T.H. 47) SHEET NO. 11 OF 15 SHEETS

KEY	SPECIES	QUANT.	SPACING
GBC_12"	CHOKEBERRY, GLOSSY BLACK	29	5' O.C.



30  
SCALE IN FEET

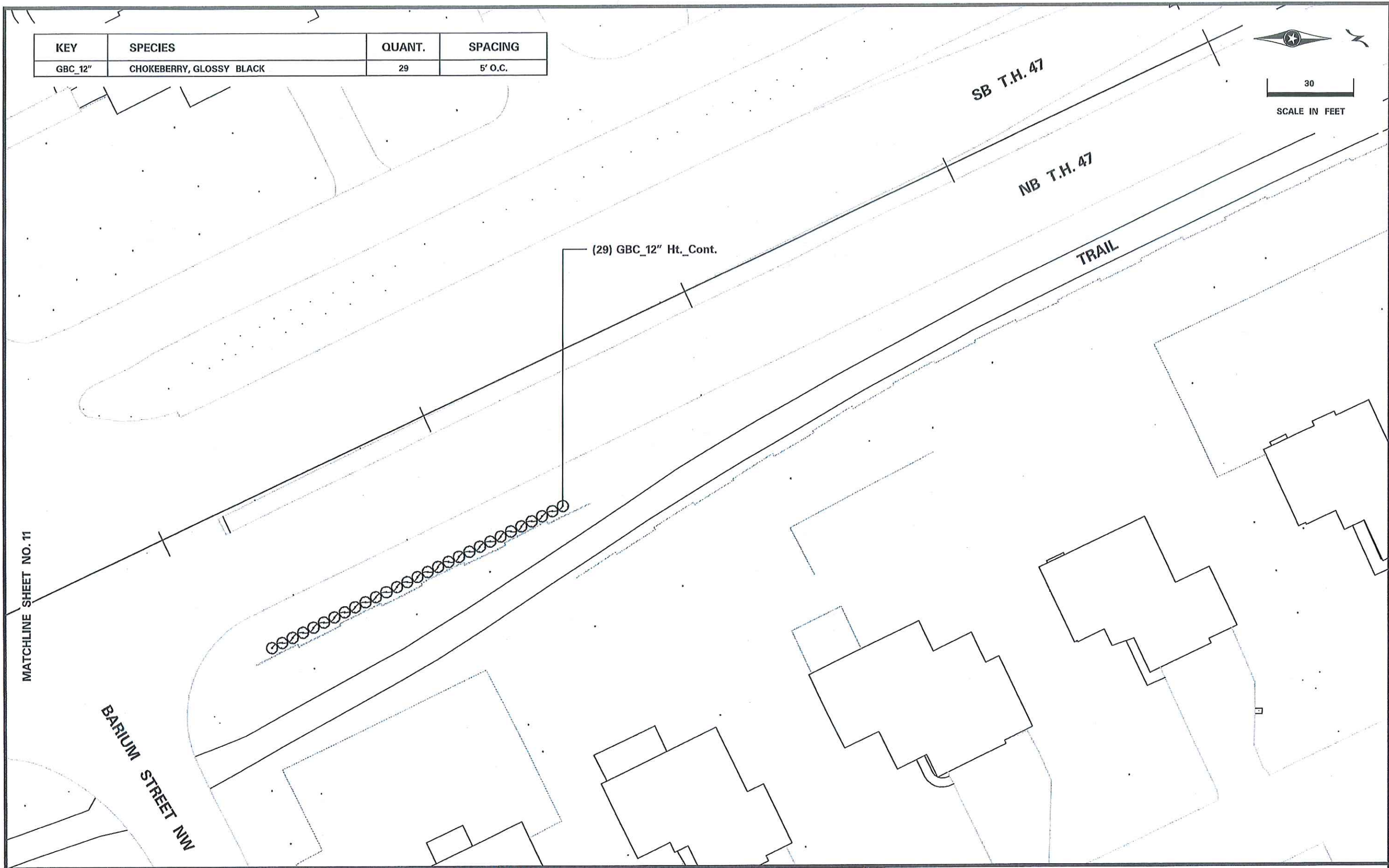

MATCHLINE SHEET NO. 11

BARIUM STREET NW

(29) GBC\_12" Ht.\_Cont.

SB T.H. 47

NB T.H. 47

TRAIL

DATE PRINTED:  
10/31/2018

TIME PRINTED:  
8:09:16 AM

PROJECT MANAGER  
PHILIP ZENGE

DRAWN BY  
PHILIP ZENGE

DATE 10/31/18 LIC. NO. 26951

CHECKED BY  
DENNIS MOLINE

SIGNATURE 

**mn** OFFICE OF ENVIRONMENTAL STEWARDSHIP  
ENV. PLANNING AND DESIGN UNIT  
DEPARTMENT OF TRANSPORTATION BUILDING  
ST. PAUL, MINNESOTA 55155-1899

**LANDSCAPE PLAN**

STATE PROJECT 0206-969A (T.H. 47)

SHEET NO. 12 OF 15 SHEETS

**GENERAL NOTES**

- SEE SPECIAL PROVISIONS FOR SPECIFIC PROJECT REQUIREMENTS.
- REFER TO MnDOT SPECIFICATIONS 2571, 2572, 3861, FOR GENERAL REQUIREMENTS.
- COMPLETE PREPARATORY WORK BEFORE STARTING INITIAL PLANTING OPERATIONS.
- ACCEPT ALL PLANT STOCK IN ACCORDANCE WITH (MnDOT 3861) PRIOR TO PLANTING.
- THE CONTRACTOR WILL DEMONSTRATE COMPETENCY FOR SOIL CULTIVATION OPERATIONS IN ACCORDANCE WITH (MnDOT 2571.3D.2)
- THE CONTRACTOR WILL DEMONSTRATE COMPETENCY FOR ALL PLANT INSTALLATION OPERATIONS IN ACCORDANCE WITH (MnDOT 2571.3F1)

RODENT PROTECTION	SEE SPECIAL PROVISIONS AND STANDARD PLANTING DETAILS (3 OF 3)
FERTILIZER	SEE SPECIAL PROVISIONS
COMPOST	MnDOT 3890 COMPOST GRADE 2 UNLESS OTHERWISE SPECIFIED.
MULCH MATERIAL	MnDOT 3882 MULCH MATERIAL TYPE 6 UNLESS OTHERWISE SPECIFIED.

**MASS PLANTING BEDS**

PREPARE MASS PLANTING BEDS FOR PLANTS PLACED AT 15' OR LESS, UNLESS OTHERWISE SPECIFIED ON SHEETS. PLANT BEDS IN STAGGERED ROWS ON THE PERIMETER FIRST, THEN UNIFORMLY FILL IN WITH REMAINING PLANTS. USE TRIANGULAR SPACING, UNLESS SPECIFIED OTHERWISE. PROVIDE 5' RADIUS CLEAR OF SHRUBS AROUND EACH DECIDUOUS TREE AND 8' CLEAR RADIUS AROUND EACH CONIFER TREE. RADIUS WILL BE MEASURED FROM THE CENTER OF THE TREE TO THE CENTER OF THE SHRUB. NOTIFY ENGINEER OF GROSS PLANT QUANTITY SURPLUS OR DEFICIENCY IMMEDIATELY. MULCH ENTIRE MASS PLANTING BED. SEE STANDARD PLANTING DETAILS (3 OF 3)

**TREE PAINTING (FROST CRACK PREVENTION)**

PAINT OAK, LINDEN, LOCUST, MAPLE, CRABAPPLE AND MOUNTAIN ASH. ONLY UNDILUTED EXTERIOR WHITE LATEX PAINT IS ACCEPTABLE. PAINT TREE CIRCUMFERENCE FROM GROUND LINE TO FIRST MAJOR BRANCH.

**PLANTING PLAN DIMENSIONS**

STATED DIMENSIONS SUPERCEDE SCALING FROM PLAN.

WATERING GUIDELINES (MnDOT 2571.3G)	PLANT TYPE	AVERAGE GALLONS OF WATER PER APPLICATION
	MACHINE TRANSPLANTED TREES	50-100
	BALLED AND BURLAPPED TREES	20
	BARE ROOT AND CONTAINER TREES	15
	BALLED AND BURLAPPED SHRUBS	10
	BARE ROOT AND CONTAINER SHRUBS	7
	WOODY SEEDLINGS	4
	PERENNIALS AND VINES	3

IT IS THE CONTRACTOR'S RESPONSIBILITY TO MONITOR AND MAINTAIN SOIL MOISTURE AT ADEQUATE BUT NOT EXCESSIVE LEVELS. THE AMOUNTS LISTED ABOVE ARE GUIDELINES, NOT REQUIREMENTS.

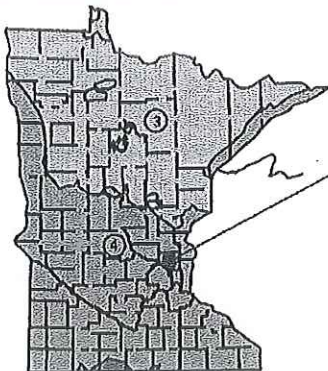

PROJECT LOCATION

**PLANTING DATES BY ZONE**

		3		4	
		APRIL 21 TO JUNE 1	APRIL 7 TO JUNE 1	APRIL 21 TO JUNE 30	APRIL 7 TO JUNE 30
SPRING	DECIDUOUS BARE ROOT	APRIL 21 TO JUNE 1	APRIL 7 TO JUNE 1	APRIL 21 TO JUNE 30	APRIL 7 TO JUNE 30
	DECIDUOUS CONTAINER B&B	APRIL 21 TO JUNE 30	APRIL 7 TO JUNE 30	APRIL 21 TO JUNE 30	APRIL 7 TO JUNE 30
	CONIFEROUS	APRIL 21 TO JUNE 1	APRIL 7 TO MAY 17	APRIL 21 TO JUNE 30	APRIL 7 TO JUNE 30
	PERENNIALS	MAY 1 TO JUNE 30	MAY 1 TO JUNE 30	MAY 1 TO JUNE 30	MAY 1 TO JUNE 30
FALL	DECIDUOUS BARE ROOT	OCT. 1 TO NOV. 1	OCT. 10 TO NOV. 15	OCT. 1 TO NOV. 15	OCT. 10 TO NOV. 15
	DECIDUOUS CONTAINER B&B	AUG. 25 TO OCT. 15	AUG. 25 TO NOV. 1	AUG. 25 TO NOV. 1	AUG. 25 TO NOV. 1
	CONIFEROUS	AUG. 25 TO SEPT. 15	AUG. 25 TO SEPT. 15	AUG. 25 TO SEPT. 15	AUG. 25 TO SEPT. 15
	PERENNIALS	AUG. 25 TO SEPT. 15	AUG. 25 TO SEPT. 15	AUG. 25 TO SEPT. 15	AUG. 25 TO SEPT. 15

- BARE ROOT PERENNIALS MUST BE PLACED IN THE SPRING NO LATER THAN JUNE 1ST OR FOLLOW THE FALL DECIDUOUS PLANTING DATES.
- ACTUAL DATES MAY CHANGE DEPENDING UPON SEASONAL CONDITIONS, AS DETERMINED BY THE ENGINEER.
- FALL PLANTING IS NOT ALLOWED FOR BARE ROOT FORM OF THE FOLLOWING SPECIES: HAWTHORN, DOGWOOD, POPLAR, HACKBERRY, LINDEN, IRONWOOD, HONEYLOCUST, BIRCH, MOUNTAIN ASH, MAPLE, WILLOW, CRABAPPLE, PLUMCHERRY, OAKS, AND SUMAC.
- ALL REPLACEMENT PLANTS MUST BE PLACED DURING THE MONTH OF MAY (SPRING PLANTING) AND SEPTEMBER (FALL PLANTING) DURING THE FIRST YEAR OF THE PLANT ESTABLISHMENT PERIOD.
- MACHINE MOVED PLANTING DATES WILL BE SPECIFIED IN THE SPECIAL PROVISIONS.

**PLANT INSTALLATION PERIOD**

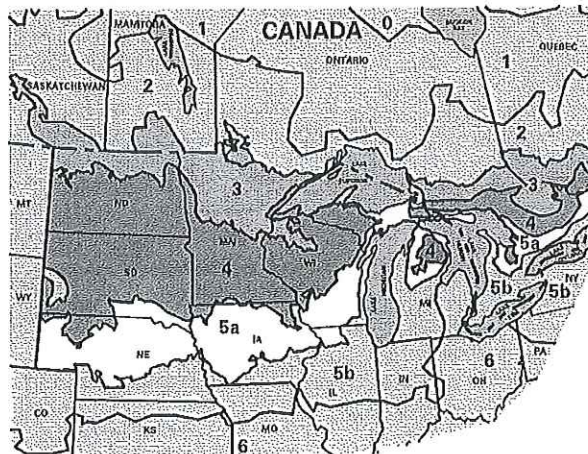

ZONES	LEGEND	MIN. TEMP.
3		-34.4° TO -40 F
4		-28.9° TO -34.4 F
5a		-26.1° TO -28.9 F

ZONES	LEGEND
0, 1, 2, 5b and 6	

FOR ALL PLANT STOCK, DOCUMENT ACCEPTABILITY FOR HARDINESS IN THE MINNESOTA ZONE WHERE THE PROJECT SITE IS LOCATED, AS FOLLOWS:

- PLANT STOCK CONTINUOUSLY GROWN FOR AT LEAST THE LAST TWO YEARS WITHIN THE ACCEPTABLE LIMITS SHOWN.
- OR
- PLANT STOCK, GROWN OUTSIDE THE ACCEPTABLE GROWING RANGE LIMITS, HAVING SEED SOURCE OR ROOT AND GRAFT STOCK ORIGINATING FROM THE ACCEPTABLE LIMITS SHOWN.

**ACCEPTABLE PLANT STOCK GROWING RANGE LIMITS**

SOURCE: USDA PLANT HARDINESS ZONE MAP (MnDOT 3861.2C)

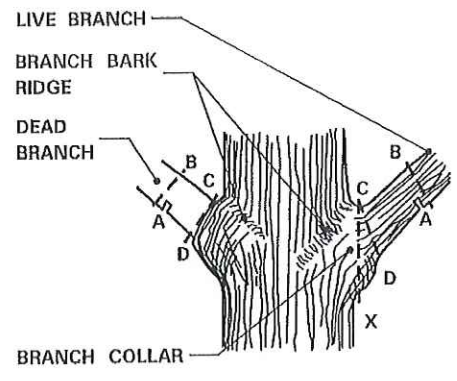

BRANCHES PRUNED AT TRUNK (SHIGO METHOD)

- STEPS TO PRUNING WITH PRUNING SAW:
- CUT PART WAY THROUGH THE BRANCH AT POINT A.
  - CUT COMPLETELY THROUGH BRANCH FROM POINT B TO A.
  - AT BRANCH COLLAR CUT FROM POINT C TO D.

INCORRECT CUT FROM POINT C TO X (TOO CLOSE) WILL RESULT IN DISCONTINUOUS CALLUS FORMATION AFTER ONE SEASON OF GROWTH.

CORRECT CUT FROM POINT C TO D (LEAVING BRANCH COLLAR BUT NOT THE STUB FROM POINT B TO A) WILL RESULT IN CONTINUOUS DOUGHNUT SHAPED CALLUS FORMATION AFTER ONE SEASON OF GROWTH.

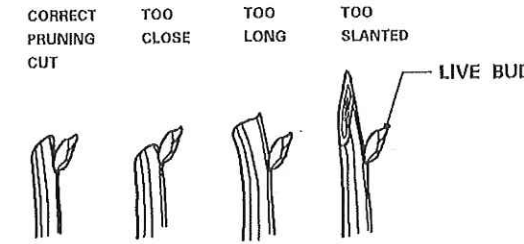

BRANCHES PRUNED TO LIVE BUD

- PRUNING NOTES:
- PRUNE USING CLEAN AND SHARP SCISSOR-TYPE PRUNER OR PRUNING SAW.
  - THE BEST TIME TO PRUNE IS LATE DORMANT SEASON OR EARLY SPRING.
  - AVOID PRUNING OAKS IN APRIL, MAY, JUNE OR JULY.
  - IF PRUNING IS NECESSARY OR IF WOUNDS OCCUR TO OAK TREES IN APRIL, MAY, JUNE OR JULY, IMMEDIATELY PAINT CUT SURFACE OR WOUND WITH LATEX PAINT OR SHELLAC.

(MnDOT 2571.3E.1 and 2571.3K.2.a(9))

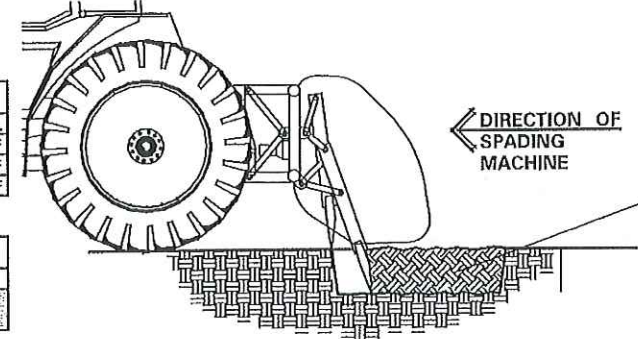

PRIMARY TILLAGE - PASS 1

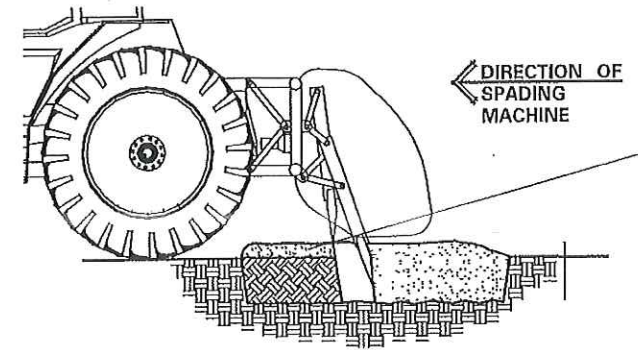

INCORPORATION TILLAGE - PASS 2

**PLANTING SOIL**

(MnDOT 2571.3D)

PLOTTED/REVISED: \$\$\$DATE\$\$\$

DISTRICT #: \$\$\$DISTRICT\$\$\$  
 I/PLOT NAME: \$\$\$I/PLOT NAME\$\$\$  
 PATH & FILENAME: \$\$\$PATH/FILENAME\$\$\$

REVISION:

APPROVED: DECEMBER 11, 2015

*[Signature]*  
 CHIEF ENVIRONMENTAL OFFICER



STANDARD PLAN 5-297.301 1 OF 3

APPROVED: 12-11-2015

REVISOR:

*[Signature]*  
 STATE DESIGN ENGINEER

STATE PROJ. NO. 0206-969A (T.H. 47)

SHEET NO. 13 OF 15 SHEETS

PLOTTED/REVISED: \$\$\$\$\$\$

DISTRICT #: \$\$\$\$ DISTRICTS \$  
 I/PLOT NAME: \$\$\$PLOT\$NAME\$\$\$  
 PATH & FILENAME: \$\$\$PATH\$FILENAME\$\$\$

**PLANTING HOLE DIMENSIONS**

HOLE DEPTH FOR B&B AND CONTAINER PLANTS SHALL NOT EXCEED MEASUREMENT FROM ROOT FLARE TO BOTTOM OF SOIL BALL.

PLANT TYPE	PLANT SIZE UP TO AND INCLUDING	(A) MINIMUM HOLE WIDTH	(B) APPROXIMATE HOLE DEPTH
DECIDUOUS & ORNAMENTAL TREES	3" B.B.	46"	13"
	4" B.B.	46"	14"
	5" B.B.	48"	14"
	6" B.B.	54"	15"
	7" B.B.	60"	16"
	8" B.B.	66"	19"
	0.75" B.R.	48"	12"
	1" B.R.	54"	14"
	1.25" B.R.	60"	14"
	1.5" B.R.	66"	15"
	1.75" B.R.	72"	16"
	2" B.R.	84"	19"
	4" B.B.	42"	11"
	5" B.B.	48"	12"
	6" B.B.	52"	14"
	8" B.B.	65"	15"
	10" B.B.	66"	16"
	12" B.B.	48"	15"
	1" B.R.	54"	14"
	1.25" B.B.	56"	15"
1.5" B.B.	61"	15"	
1.75" B.B.	66"	16"	
2" B.B.	72"	16"	
2.5" B.B.	84"	19"	
3" B.B.	96"	20"	
3.5" B.B.	114"	23"	
4" B.B.	126"	25"	
12" B.R.	24"	7"	
15" B.R.	28"	8"	
18" B.R.	30"	8"	
2" B.R.	33"	9"	
3" B.R.	42"	11"	
4" B.B.	48"	12"	
5" B.R.	54"	14"	
6" B.R.	60"	14"	
10" B.B.	27"	7"	
2" B.R.	30"	8"	
3" B.B.	36"	9"	
4" B.B.	42"	11"	
5" B.B.	48"	12"	
6" B.B.	54"	14"	
DECIDUOUS SHRUBS, ROSES AND PERENNIALS	3" B.B.	42"	11"
	4" B.B.	48"	12"
	5" B.R.	54"	14"
	6" B.R.	60"	14"
PERENNIAL HOLE DEPTH AND WIDTH SHALL BE BASED UPON ON-CENTER SPACING IN A CONTINUOUS TRENCH.	10" B.B.	27"	7"
	2" B.R.	30"	8"
	3" B.B.	36"	9"
	4" B.B.	42"	11"

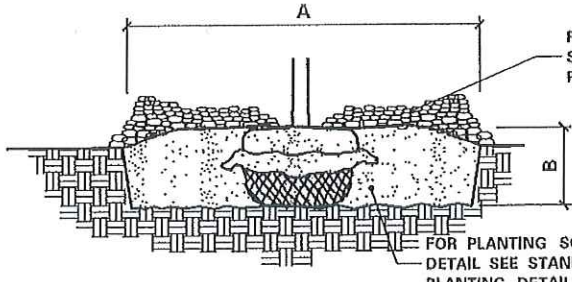

1. SCARIFY SIDES AND BOTTOM OF HOLE.
2. PROCEED WITH CORRECTIVE PRUNING.
3. SET PLANT ON UNDISTURBED NATIVE SOIL OR THOROUGHLY COMPACTED PLANTING SOIL. PLACE PLANT SO THE ROOT FLARE IS AT OR UP TO 2" ABOVE THE FINISHED GRADE WITH BURLAP AND WIRE BASKET, (IF USED), INTACT.
4. SLIT REMAINING TREATED BURLAP AT 6" INTERVALS.
5. BACKFILL TO WITHIN APPROXIMATELY 12" OF THE TOP OF THE ROOTBALL, THEN WATER PLANT.
6. REMOVE THE TOP 1/3 OF THE BASKET OR THE TOP TWO HORIZONTAL RINGS WHICHEVER IS GREATER. REMOVE ALL BURLAP AND NAILS FROM THE TOP 1/3 OF THE BALL. REMOVE ALL TWINE. REMOVE OR CORRECT STEM GIRDLING ROOTS.
7. PLUMB AND BACKFILL WITH PLANTING SOIL.
8. WATER THOROUGHLY WITHIN 2 HOURS TO SETTLE PLANTS AND FILL VOIDS.
9. BACK FILL VOIDS AND WATER A SECOND TIME.
10. PLACE MULCH WITHIN 48 HOURS OF THE SECOND WATERING UNLESS SOIL MOISTURE IS EXCESSIVE.

**BALLED & BURLAPPED STOCK**

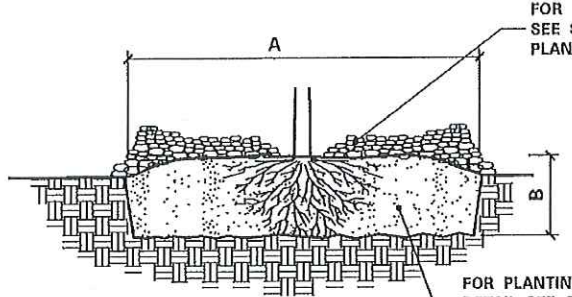

1. SOAK ROOTS IN WATER FOR AT LEAST ONE HOUR BUT NOT MORE THAN 24 HOURS PRIOR TO PLANTING.
2. SCARIFY SIDES AND BOTTOM OF HOLE.
3. PROCEED WITH CORRECTIVE PRUNING OF THE TOP AND ROOTS.
4. TRANSFER PLANT DIRECTLY FROM WATER TO HOLE. SET PLANT SO THE ROOT FLARE IS AT THE FINISHED SOIL ELEVATION. SPREAD ROOTS OUT EVENLY. PLUMB AND IMMEDIATELY BACKFILL WITH PLANTING SOIL.
5. WATER THOROUGHLY WITHIN 2 HOURS TO SETTLE PLANTS AND FILL VOIDS.
6. BACK FILL VOIDS AND WATER A SECOND TIME.
7. PLACE MULCH WITHIN 48 HOURS OF THE SECOND WATERING UNLESS SOIL MOISTURE IS EXCESSIVE.

**BARE ROOT STOCK**

**INSTALLATION OF PLANTS**

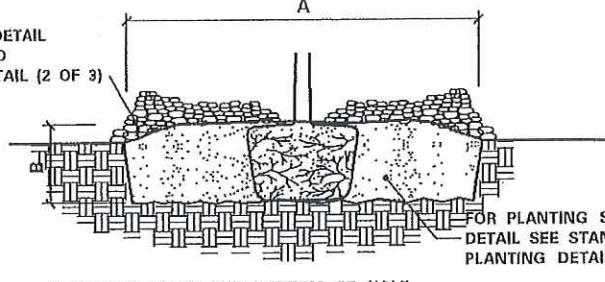

1. SCARIFY SIDES AND BOTTOM OF HOLE.
2. PROCEED WITH CORRECTIVE PRUNING OF TOP AND ROOT.
3. REMOVE CONTAINER AND SCORE OUTSIDE OF SOIL MASS TO REDIRECT AND PREVENT CIRCLING FIBROUS ROOTS. REMOVE OR CORRECT STEM GIRDLING ROOTS.
4. SET PLANT ON UNDISTURBED NATIVE SOIL OR THOROUGHLY COMPACTED PLANTING SOIL. INSTALL PLANT SO THE TOP OF THE ROOT FLARE IS AT OR UP TO 2" ABOVE THE FINISHED GRADE.
5. PLUMB AND BACKFILL WITH PLANTING SOIL.
6. WATER THOROUGHLY WITHIN 2 HOURS TO SETTLE PLANT AND FILL VOIDS.
7. BACK FILL VOIDS AND WATER A SECOND TIME.
8. PLACE MULCH WITHIN 48 HOURS OF THE SECOND WATERING UNLESS SOIL MOISTURE IS EXCESSIVE.

**CONTAINER STOCK**

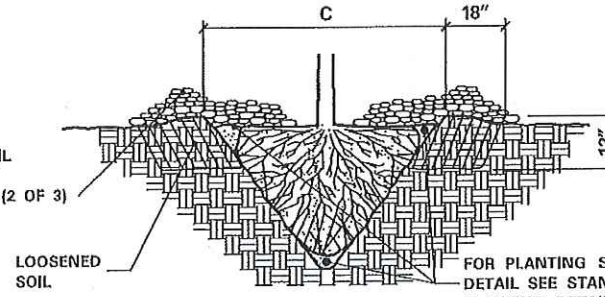

1. SCARIFY SIDES AND BOTTOM OF HOLE.
2. PROCEED WITH CORRECTIVE PRUNING.
3. SET PLANT ON NATIVE SOIL AT SAME DEPTH AS IT WAS PREVIOUSLY GROWN.
4. PLUMB AND BACKFILL WITH PLANTING SOIL.
5. AFTER PLANTING, LOOSEN THE SOIL IMMEDIATELY ADJACENT TO THE ROOT BALL TO A MINIMUM DISTANCE OF 18" AND A MINIMUM DEPTH OF 12".
6. WATER THOROUGHLY WITHIN 2 HOURS TO SETTLE PLANT AND FILL VOIDS.
7. BACK FILL VOIDS AND WATER A SECOND TIME.
8. PLACE MULCH WITHIN 48 HOURS OF THE SECOND WATERING UNLESS SOIL MOISTURE IS EXCESSIVE.

**MINIMUM TREE SPADE SIZE REQUIREMENTS**

(C) SPADE DIAMETER SIZE	OAK TREE, CALIPER	DECIDUOUS / ORNAMENTAL TREE, CALIPER	CONIFEROUS TREE, HEIGHT
42"	1" to 1.5"	2" to 3"	5' to 7'
60"	1.5" to 2.5"	3" to 4"	7' to 9'
78"	2.5" to 3.5"	4" to 6"	9' to 14'
85"	3.5" to 5"	6" to 8"	14' to 18'

**MACHINE MOVED STOCK**

**PLANTING HOLE DIMENSIONS**

HOLE DEPTH FOR B&B AND CONTAINER PLANTS SHALL NOT EXCEED MEASUREMENT FROM ROOT FLARE TO BOTTOM OF SOIL BALL.

PLANT TYPE	PLANT SIZE UP TO AND INCLUDING	(A) MINIMUM HOLE WIDTH	(B) APPROXIMATE HOLE DEPTH
CONIFEROUS TREES	2" B.B.	36"	10"
	3" B.B.	42"	11"
	4" B.B.	51"	13"
	5" B.B.	60"	13"
	6" B.B.	66"	15"
	7" B.B.	72"	16"
	8" B.B.	81"	18"
	9" B.B.	90"	20"
	10" B.B.	102"	21"
	12" B.B.	114"	24"
CONIFEROUS SHRUBS (UPRIGHT)	18" SPR B.B.	24"	7"
	3" B.B.	48"	12"
CONIFEROUS SHRUBS (SPREADING)	18" SPR B.B.	30"	8"
	2" SPR B.B.	36"	9"
CONTAINER GROWN PLANTS	CELLPACKS / PLUGS	6"	2.5"
	2.25" CONT.	7"	3"
	3.5" CONT.	10"	3"
	4" CONT.	11"	4"
	4.5" CONT.	13"	4"
	5.75" QT CONT.	15"	5.5"
	1# CONT.	18"	6"
	2# CONT.	23"	7.5"
	3# CONT.	25"	8.5"
	5# CONT.	30"	11"
SEEDLINGS	7# CONT.	37"	11"
	15# CONT.	44"	14"
	10# CONT.	45"	15"
	20# CONT.	60"	16"
	25# CONT.	72"	17"
	6" SEEDLING	15"	14"
	9" SEEDLING	18"	14"
	12" SEEDLING	23"	16"
	18" SEEDLING	30"	16"
	2" SEEDLING	36"	19"
VINES	1 YR. MED. B.R.	15"	11"
	1 YR. NO. 1 B.R.	17"	14"
	2 YR. MED. B.R.	33"	12"
	2 YR. NO. 1 B.R.	42"	15"

**MULCH AREA CALCULATOR**

TYPE OF PLANT	SQ. FT. PER PLANT
CONIFEROUS TREES	$\left[ \frac{(3/5 \times \text{HEIGHT}) + 3}{2} \right]^2 \times \pi$
DECIDUOUS AND ORNAMENTAL TREES	$3^2 \times \pi$
CONIFEROUS AND DECIDUOUS SHRUBS, ROSE BUSHES, PERENNIALS, ORNAMENTAL GRASS	SPACING x SPACING
VINES	SPACING x 2
MACHINE-MOVED TREES OR SHRUBS	$\left[ \frac{(\text{SPADE DIAMETER}) + 1}{2} \right]^2 \times \pi$

$\pi = 3.1416$

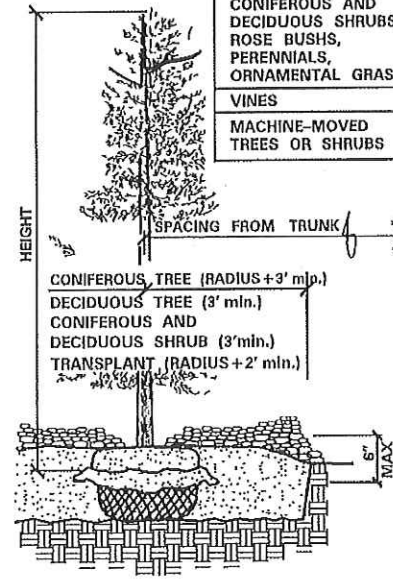

1. PULL MULCH BACK NO LESS THAN 3" AND NO MORE THAN 6" FROM TRUNK AND SHRUBS AT THE TRUNK OR MAIN STEM.
2. SUBSIDING OR DETERIORATING MULCH IS ACCEPTABLE THROUGHOUT THE ESTABLISHED PERIOD IF THE MULCH DEPTH IS MAINTAINED AT A MINIMUM 3" DEPTH.
3. ADD MULCH WHEN BELOW THE 3" MINIMUM DEPTH; DO NOT EXCEED THE 6" MAXIMUM DEPTH.
4. MULCH CONTAMINATED WITH SOIL MUST BE REMOVED AND REPLACED.

**MULCH**

(MnDOT 2571.3F)

**WALL INSTALLATION**

**FENCE INSTALLATION**

**INSTALLATION OF VINES**

REVISION:  
 APPROVED: DECEMBER 11, 2015



STANDARD PLAN 5-297.301 2 OF 3  
 APPROVED: 12-11-2015  
 REVISED:  
  
 STATE PROJ. NO. 0206-969A (T.H. 47)

**STANDARD PLANTING DETAILS**

SHEET NO. 14 OF 15 SHEETS

PLOTTED/REVISED: \$\$\$DATE\$\$\$

DISTRICT: \$\$\$DISTRICT\$\$\$  
 PLOT NAME: \$\$\$PLOTNAME\$\$\$  
 PATH & FILENAME: \$\$\$PATHFILENAME\$\$\$

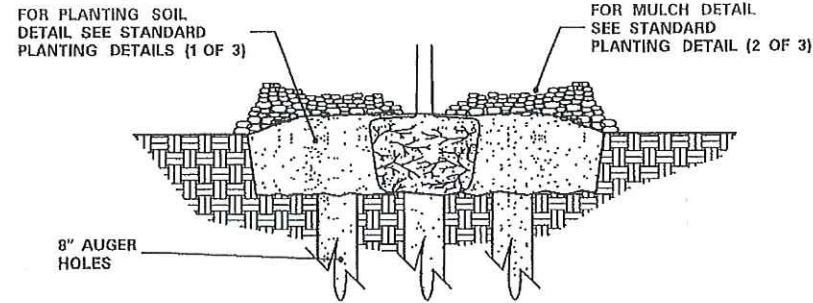

1. EXCAVATE HOLE OR BED TO ALLOW PLACING THE TOP OF ROOT MASS 1"-3" HIGHER THAN FINISHED GRADE.
2. AUGER 8" DIAMETER HOLES ENTIRELY THROUGH IMPERVIOUS OR POORLY DRAINED HARD PAN SOIL LAYER TO ADEQUATELY DRAIN SUBSOIL.
3. TEST FOR POSITIVE DRAINAGE. RE-AUGER AN ADDITIONAL 8" IF NECESSARY FOR POSITIVE DRAINAGE.
4. THOROUGHLY BACKFILL AUGER HOLES WITH A UNIFORM INCORPORATED MIXTURE OF 50% SAND AND 50% INPLACE SOIL.
5. COMPLETE PLANTING ACCORDING TO ROOT TYPE. SEE STANDARD PLANTING DETAILS (2 OF 3).

**GRANULAR FILTER**

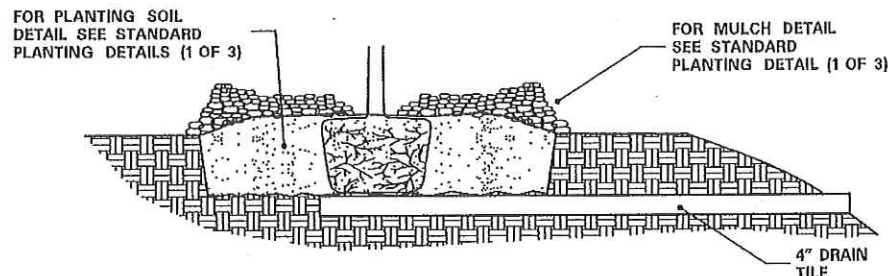

1. EXCAVATE HOLE OR BED TO ALLOW PLACING THE TOP OF THE ROOT MASS 1"-3" HIGHER THAN FINISHED GRADE.
2. INSTALL 4" MINIMUM DIAMETER DRAIN TILE DAYLIGHTING AT A LOWER GRADE.
3. COMPLETE PLANTING ACCORDING TO ROOT TYPE. SEE STANDARD PLANTING DETAILS (2 OF 3).

**TILE DRAINAGE**

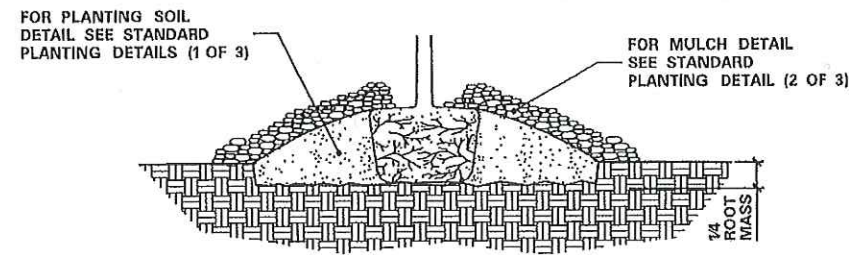

1. EXCAVATE HOLE OR BED 1/4 THE DEPTH OF THE ROOT MASS.
2. SET ROOT MASS IN HOLE.
3. CONSTRUCT BERM WITH PLANTING SOIL. EXTEND THE BERM BASE TO A WIDTH OF 3 TIMES THE BERM HEIGHT.
4. COMPLETE PLANTING ACCORDING ROOT TYPE. SEE STANDARD PLANTING DETAILS (2 OF 3).

**MINI-BERM**

NOTE:  
 1. THE NEED FOR USING PLANTING DETAILS FOR POORLY DRAINED SOILS AND WHICH TYPE TO USE ARE DETERMINED BY THE CONTRACTOR, SUBJECT TO ENGINEER APPROVAL.

**PLANTING DETAIL FOR POORLY DRAINED SOILS**

(MnDOT 2571.3D.2(8))

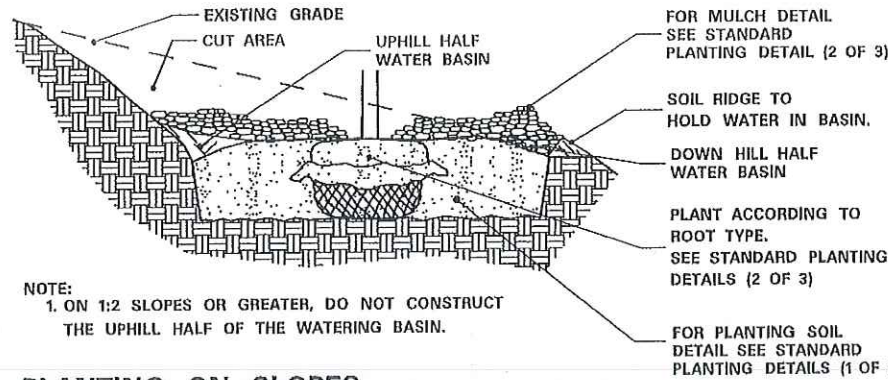

**PLANTING ON SLOPES**

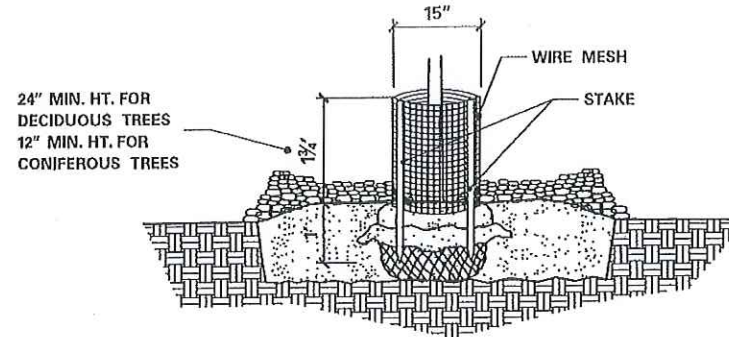

1. FORM A DOUBLE-LAYERED CYLINDER USING 0.25" GRID GALVANIZED WELDED WIRE MESH (HARDWARE CLOTH). OVERLAP THE CUT END 2".
2. DRIVE TWO 1" x 1" OPPOSING HEARTWOOD WHITE OAK STAKES INTO THE GROUND, 7" FROM THE CENTER OF THE TREE STEM.
3. SECURE THE MESH CYLINDER TO THE OUTSIDE OF THE STAKES USING EITHER, SCREWS AND WASHERS OR CABLE-TIES ALONG THE OVERLAP. SPACE APPROXIMATELY 4" ON CENTER ALONG THE OVERLAP.
  - a. SCREWS SHALL BE ROUND HEAD GALVANIZED 1/8" DIA. x 3/4" LONG WITH WASHERS.
  - OR
  - b. CABLE-TIES SHALL BE NYLON, AT LEAST 8" LONG AND BETWEEN 75LB TO 120LB TENSILE STRENGTH.
4. EMBED THE LOWER EDGE OF THE MESH CYLINDER 1" BELOW THE SOIL SURFACE WITHOUT DISTURBING THE TREE ROOTS.
5. CUT EDGES WILL NOT BE PERMITTED AT THE TOP OF THE CYLINDER. STAKE WILL BE FLUSH WITH THE TOP OF THE CYLINDER.
6. MULCH WITHIN THE CYLINDER SHALL NOT EXCEED 3" DEPTH AND SHALL BE PULLED BACK FROM THE TRUNK AS SPECIFIED IN MULCH PLACEMENT DETAIL.
7. THE BOTTOM WHORL OF PINE AND LARCH BRANCHES MAY HAVE TO BE REMOVED TO PERMIT INSTALLATION OF 12" MIN. HEIGHT RODENT GUARDS.
8. INSTALL ON ALL DECIDUOUS, PINE AND LARCH TREES, DO NOT PLACE ON SPRUCE TREES.

**RODENT PROTECTION**

(MnDOT 2571.3I.2)

1. USE SEAMLESS, EXTRUDED, TWIN-WALL, RIGID AND SEMI TRANSLUCENT POLYPROPYLENE TUBES WITH A LASER LINE PERFORATION AND AN OUTWARD-FLARED TOP RIM.
2. SECURE SHELTER WITH NYLON CABLE-TIES ATTACHED TO A 1" x 1" WHITE OAK STAKE TO PREVENT DISLODGING OR TWISTING.
3. EMBED THE BOTTOM OF THE TUBE A MINIMUM OF 1" BELOW THE SOIL SURFACE WITHOUT DISTURBING THE TREE ROOTS.
4. PLACE A PLASTIC PHOTODEGRADABLE NETTING COVER AND SLEEVE OVER THE TOP OF THE TUBE. PULL NETTING DOWN AS SHOWN.

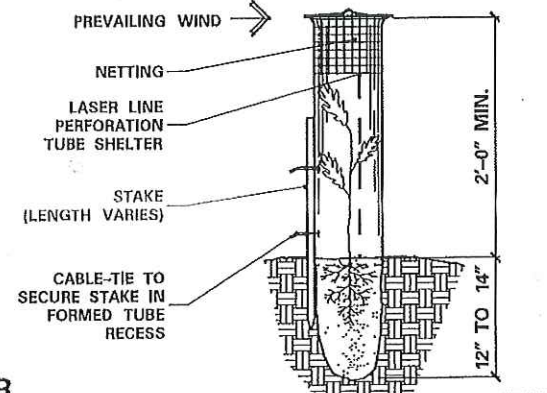

**SEEDLING TREE SHELTER**

(MnDOT 2571.3I.4)

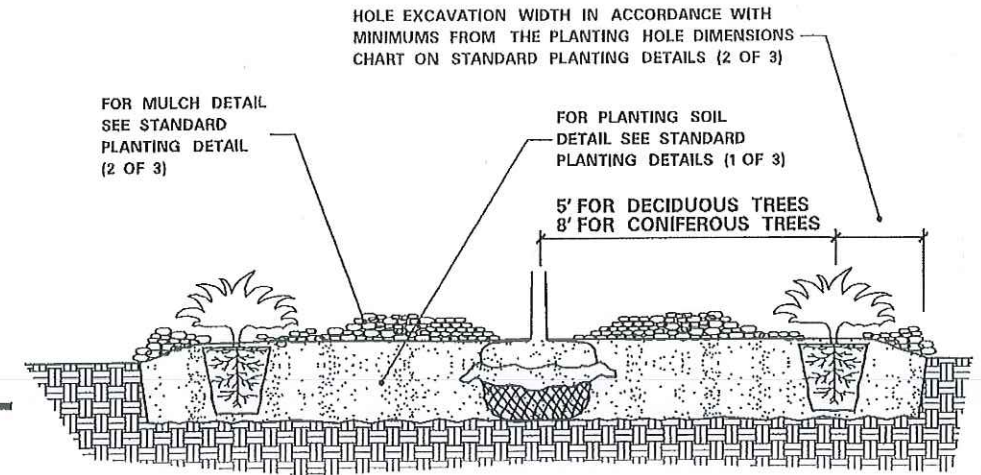

**PLANT SPACING IN MASS BEDS**

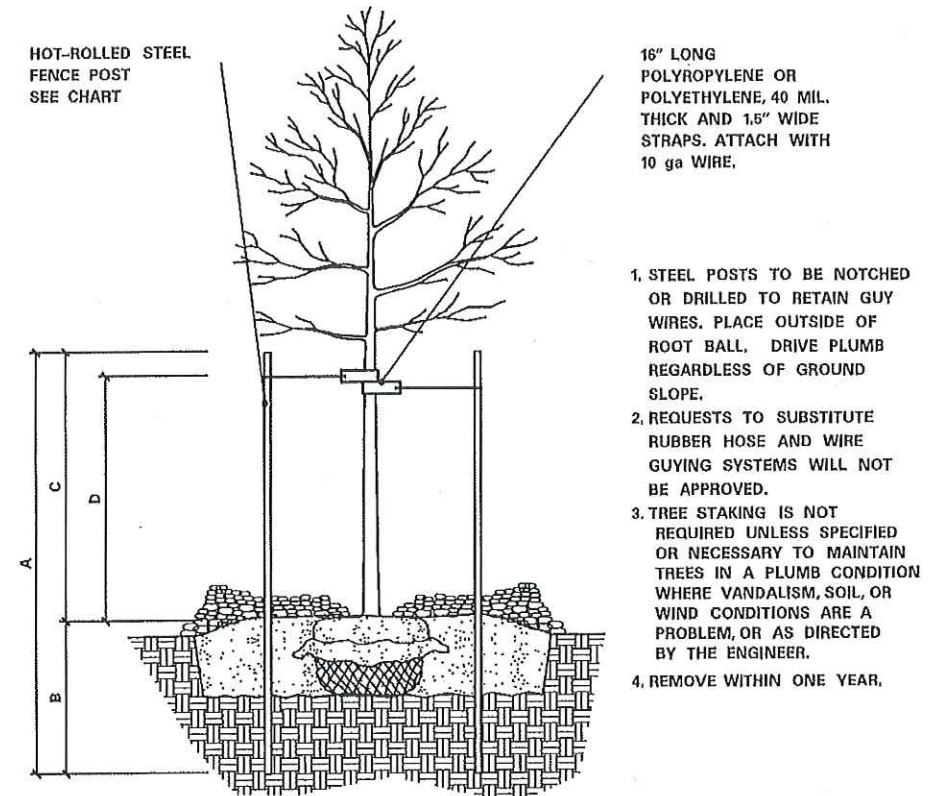

1. STEEL POSTS TO BE NOTCHED OR DRILLED TO RETAIN GUY WIRES. PLACE OUTSIDE OF ROOT BALL. DRIVE PLUMB REGARDLESS OF GROUND SLOPE.
2. REQUESTS TO SUBSTITUTE RUBBER HOSE AND WIRE GUYING SYSTEMS WILL NOT BE APPROVED.
3. TREE STAKING IS NOT REQUIRED UNLESS SPECIFIED OR NECESSARY TO MAINTAIN TREES IN A PLUMB CONDITION WHERE VANDALISM, SOIL, OR WIND CONDITIONS ARE A PROBLEM, OR AS DIRECTED BY THE ENGINEER.
4. REMOVE WITHIN ONE YEAR.

STEEL POST SIZING				
CALIPER	STEEL POST TYPE	A	B	C D
LESS THAN 4 INCHES	HOT-ROLLED STEEL FENCE POST (MnDOT 3403) OR APPROVED EQUAL.	7'-0"	3'-0" MIN.	4'-0" 3'-0"
GREATER THAN 4 INCHES	10" 2.2 LB. FLANGED CHANNEL SIGN POST (MnDOT 3401) OR APPROVED EQUAL.	10'-0"	4'-0" MIN.	6'-0" 5'-0"

**STAKING AND GUYING**

(MnDOT 2571.3I.1)

REVISIONS:  
 APPROVED: DECEMBER 11, 2015  
*[Signature]*  
 CHIEF ENVIRONMENTAL OFFICER

**m** MINNESOTA DEPARTMENT OF TRANSPORTATION  
 STANDARD PLAN 5-297.301 3 OF 3  
 APPROVED: 12-11-2015  
 REVISED:  
*[Signature]*  
 STATE DESIGN ENGINEER

STATE PROJ. NO. 0206-969A (T.H. 47)

**STANDARD PLANTING DETAILS**

SHEET NO. 15 OF 15 SHEETS

**Public Works Committee**

6. 1.

**Meeting Date:** 12/18/2018

**By:** Bruce Westby, Engineering/Public Works

---

**Title:**

Review Drainage Concerns at 17290 Germanium Street NW

**Purpose/Background:**

**Purpose:**

The property owner at 17290 Germanium Street NW informed the City Council on November 13, 2018 that he was concerned the runoff from the Covenant Meadows residential development was flooding his property. He also said the City Engineer had been unresponsive to his concerns and requests.

Staff will present information during the Public Works Committee meeting in response to the property owners concerns. Staff invited the property owner to attend the meeting.

**Background:**

The property owner at 17290 Germanium Street NW built their home in 1992. They built a garage in the southwest corner of the property in 1998, which was rebuilt in 2005 after the first garage burned down. The garage was constructed in a low area of the lot, and was not elevated. The garage door faced a private property which was used to access Germanium Street approximately 300-feet to the west.

In 2017, construction began on the Covenant Meadows residential development, which included construction of a new public street (172nd Lane NW) abutting the south property line of 17290 Germanium Street NW. During construction of this development, the property owner contacted City Staff and the developer on numerous occasions to request modifications to the new driveway installed between his garage and 172nd Lane NW. He also requested grading modifications to prevent drainage from entering his property from the north and west, noting he had issues with standing water on his property.

Before Covenant Meadows was developed (pre-development), 11.125 acres of land drained onto this property from the north and the west, contributing 3.1 cubic feet per second of runoff from a 100-year storm event.

After Covenant Meadows was developed (post-development), 1.306 acres of land drain onto this property from the north and the west, contributing 0.75 cubic feet per second of runoff from a 100-year storm event.

Attached is a memo from the Engineering Department outlining pre and post-development drainage conditions. Also attached are maps showing the pre and post-drainage areas that contribute runoff onto this property.

Regarding Staff's responsiveness to this property owner during construction of Covenant Meadows, documentation is still being gathered and will be presented in detail during the meeting.

Senior Engineering Inspector Mike McDowall and Civil Engineer IV Leonard Linton will attend the meeting to provide additional insight, information and documentation as needed. The developer also plans to attend to provide input as needed.

**Timeframe:**

Approximately 25 minutes for presentation and discussion.

**Observations/Alternatives:**

Staff believes this property benefited from the Covenant Meadows development in terms of reducing the amount of drainage entering the property. As noted above the

Staff also believes we were very responsive to this resident during construction of the Covenant Meadows development. Staff had many phone conversations with the property owner, and met with him on site numerous times. Again, more information will be presented during the meeting.

**Funding Source:**

N/A

**Recommendation:**

N/A

**Action:**

To be determined based on discussions.

---

**Attachments**

[Pre-Dev Drainage Area Map](#)

[Post-Dev Drainage Area Map](#)

[Existing Contours Map](#)

[Digital Elevation Map](#)

[Tech Memo](#)

---

**Form Review**

<b>Inbox</b>	<b>Reviewed By</b>	<b>Date</b>
Grant Riemer	MaryJo Warner	12/13/2018 04:11 PM
Kurt Ulrich	MaryJo Warner	12/13/2018 04:15 PM
Form Started By: Bruce Westby		Started On: 12/11/2018 10:25 AM
Final Approval Date: 12/13/2018		

# Covenant Meadows Pre-Development Drainage Map

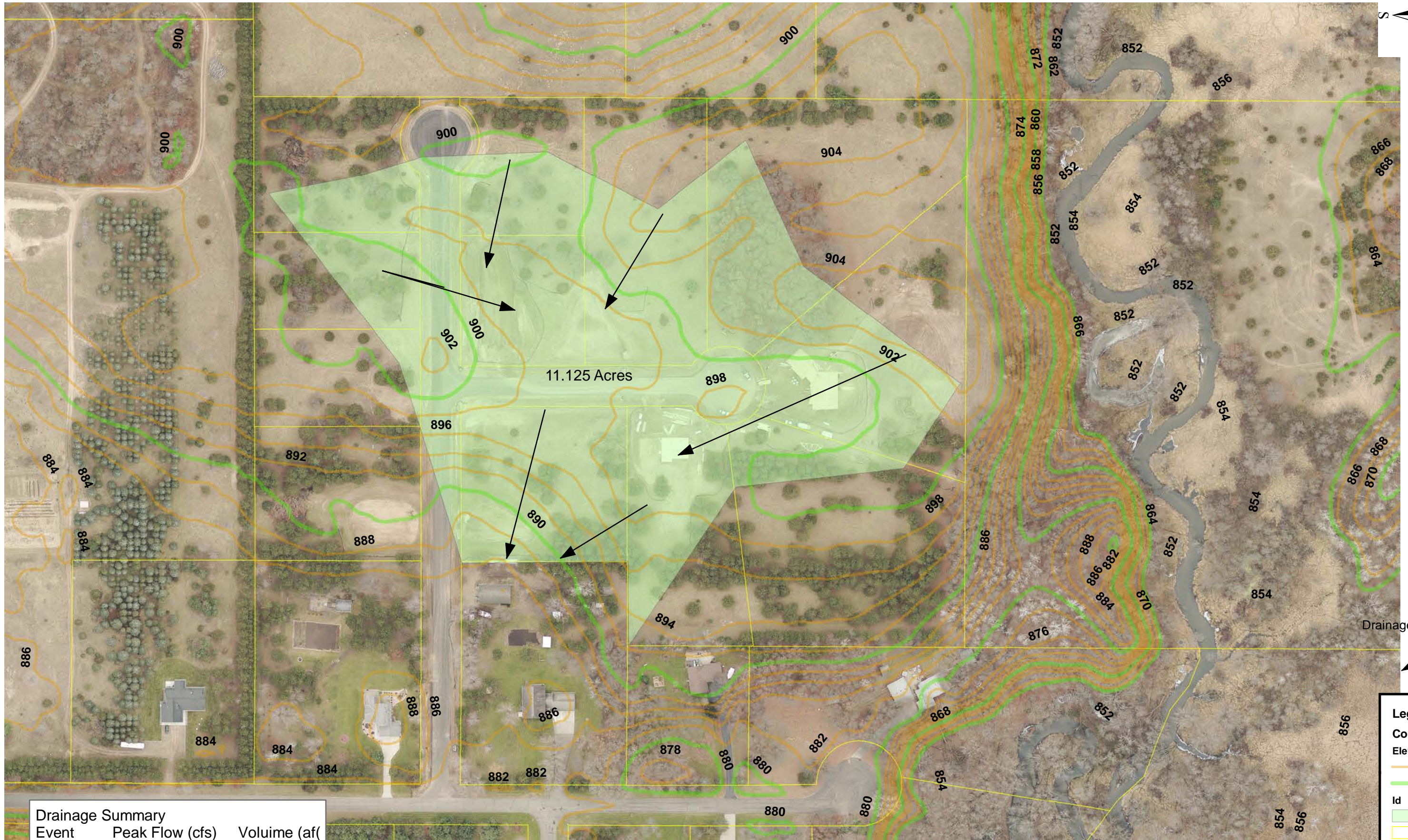
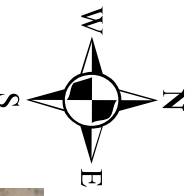

11.125 Acres

Drainage Direction

Drainage Summary		
Event	Peak Flow (cfs)	Volume (af)
2 yr	0.0	0.0
10 yr	0.1	0.07
100 yr	3.1	0.7

**Legend**

**Contours**

Elevation

- 2 ft
- 10 ft

**Id**

- Existing
- Parcels

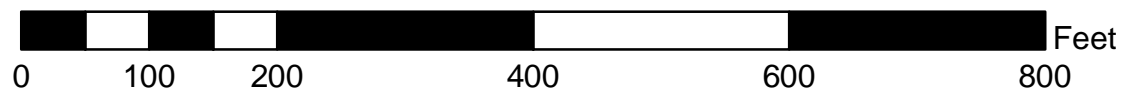

# Covenant Meadows Post-Development Drainage Map

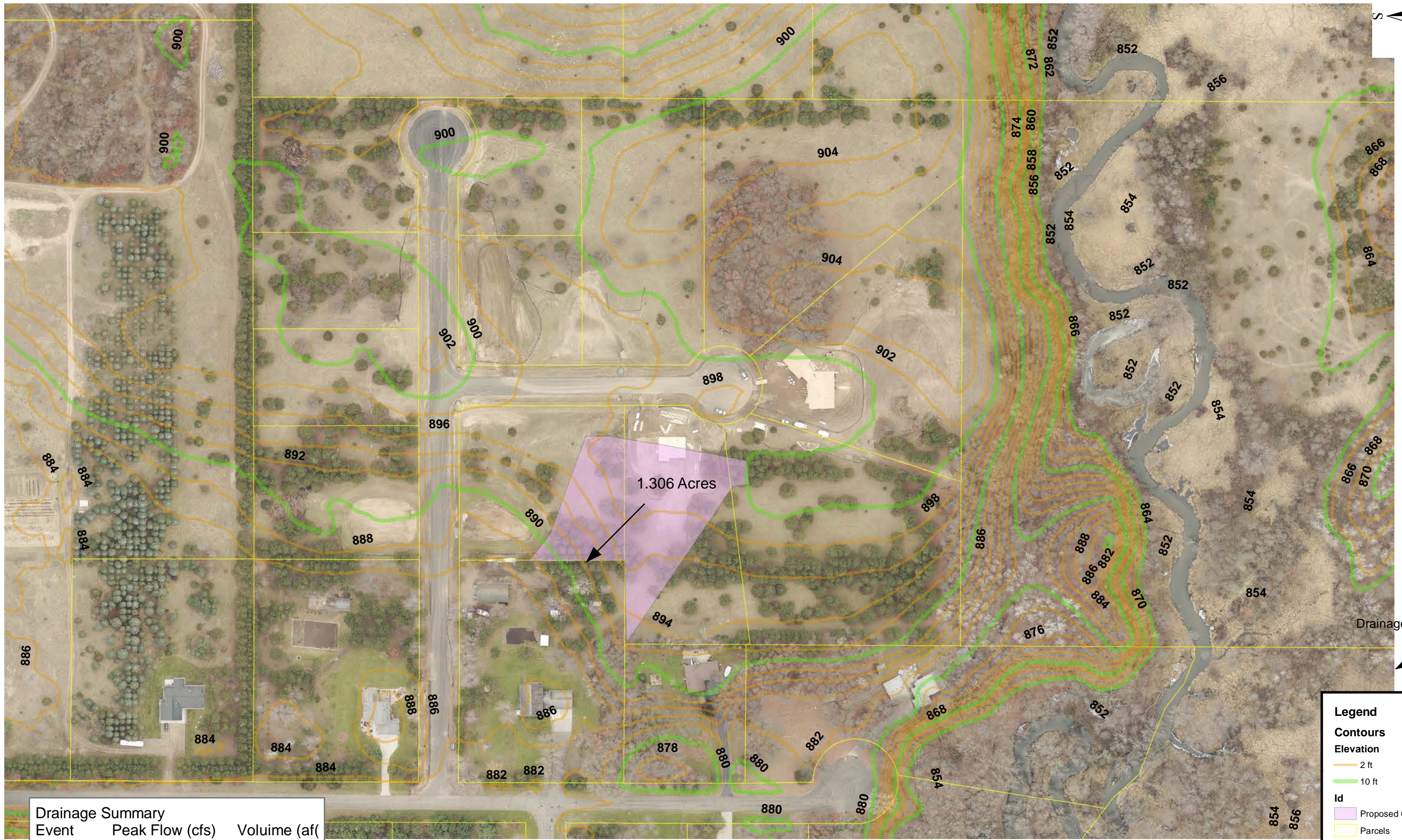
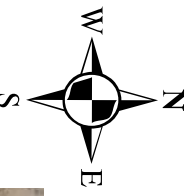

1.306 Acres

Drainage Direction

Drainage Summary		
Event	Peak Flow (cfs)	Volume (af)
2 yr	0.0	0.0
10 yr	0.02	0.008
100 yr	0.75	0.09

**Legend**

**Contours**

Elevation

- 2 ft
- 10 ft

**Id**

- Proposed Conditions
- Parcels

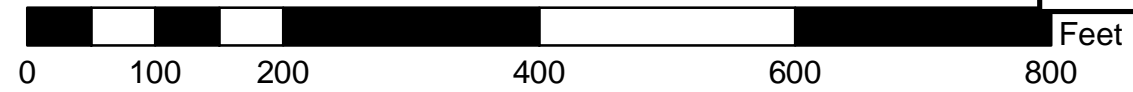

# Covenant Meadows Existing Residence Detail Map

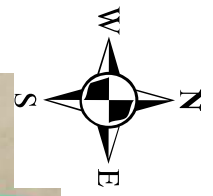
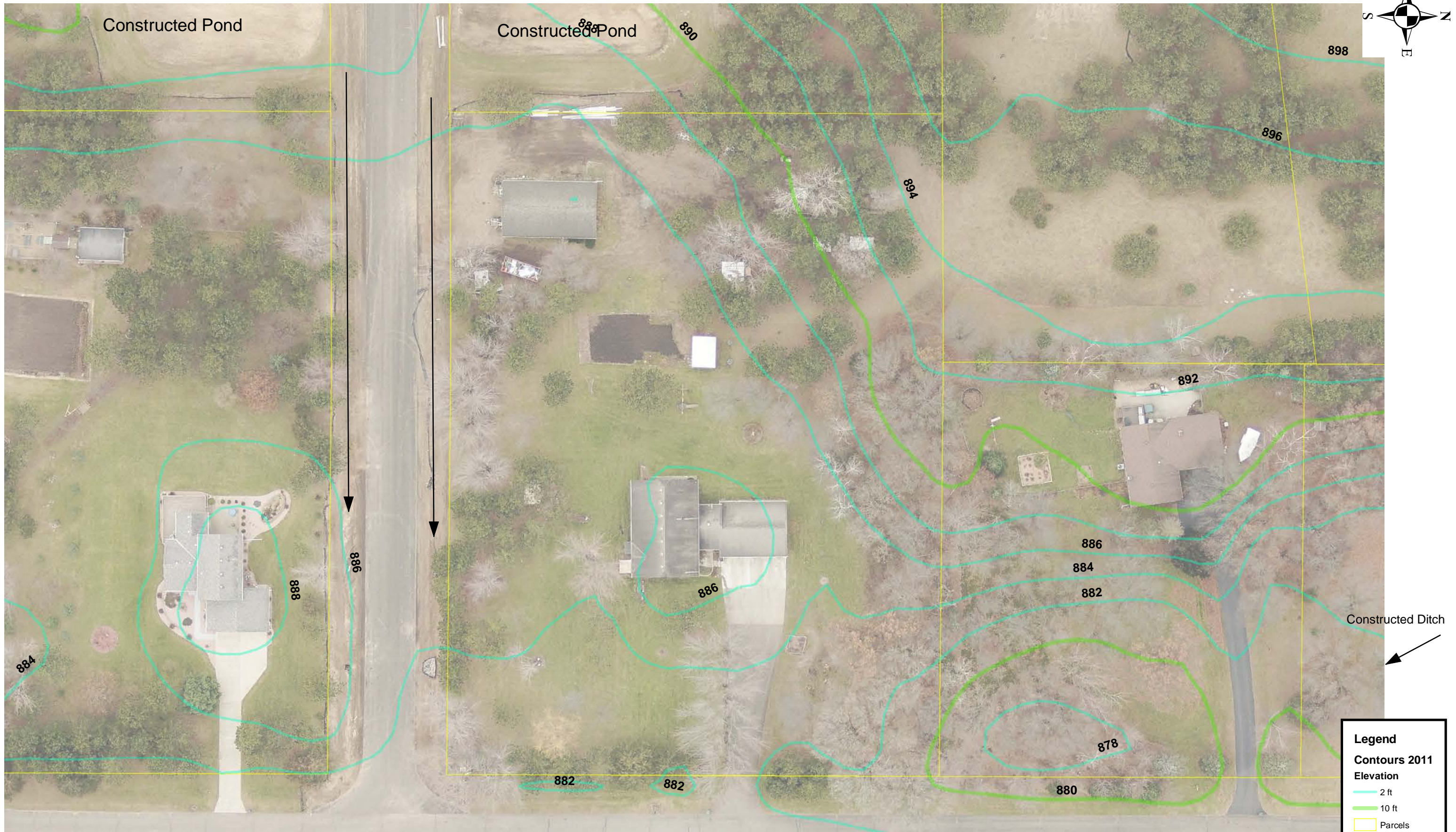

**Legend**

**Contours 2011**

**Elevation**

- 2 ft
- 10 ft

**Parcels**

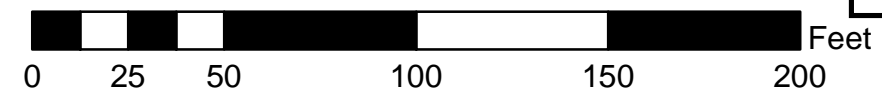

# Covenant Meadows Existing Residence Detail Map

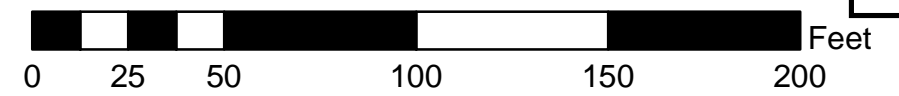
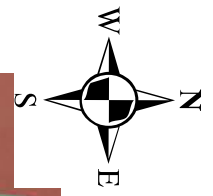
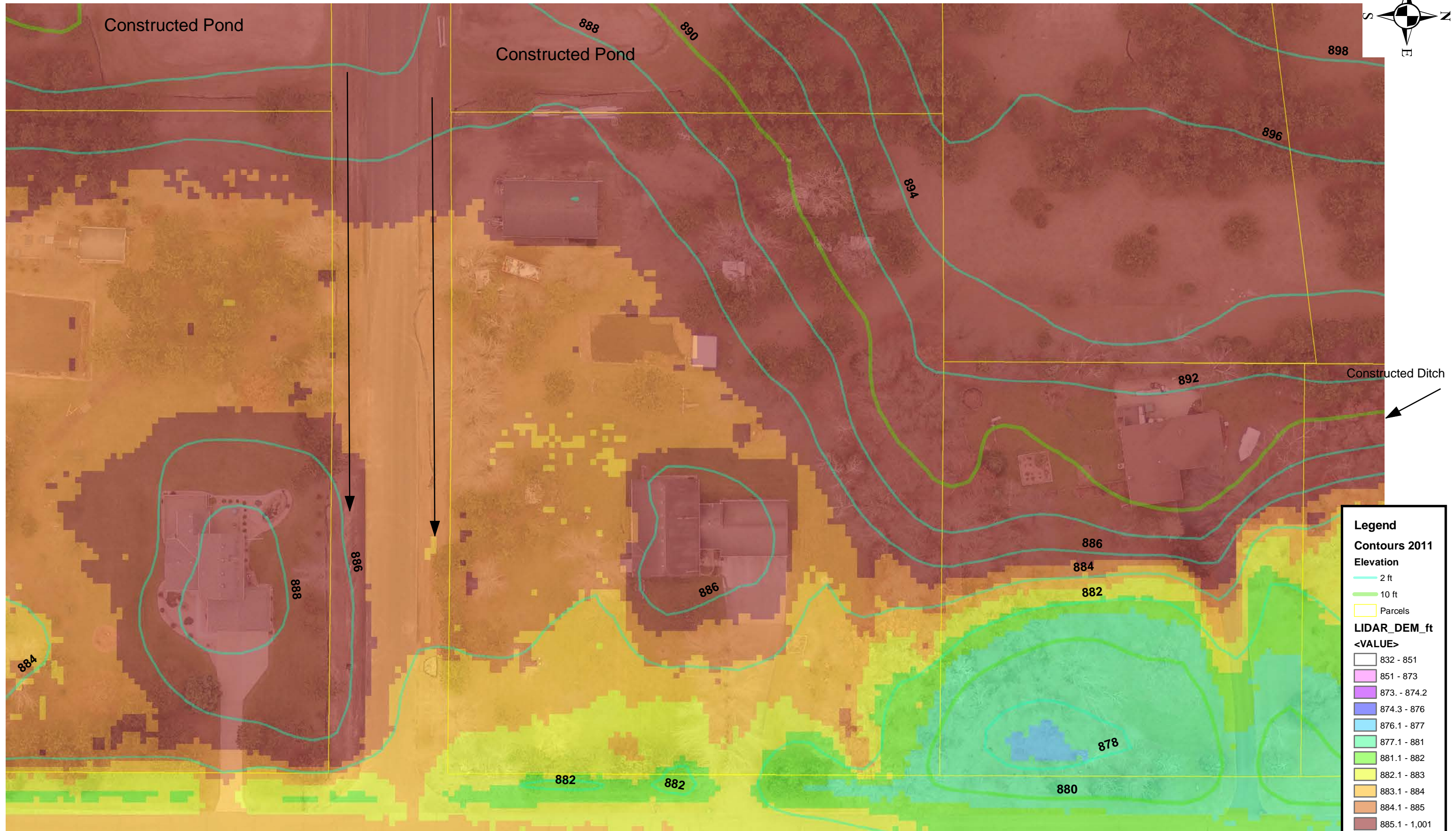

**CITY OF RAMSEY LAND USE APPLICATION  
TECHNICAL REVIEW FILE**

<b>DATE</b>	DECEMBER 12, 2018	<b>PROJECT ADDRESS</b>	WEST OF GERMANIUM STREET, NORTH OF 172 <sup>ND</sup> LANE (NEW)
<b>PROJECT. TITLE</b>	COVENANT MEADOWS		
<b>ESCROW #</b>			
<b>DEPARTMENT:</b>	Engineering		
<b>TECHNICAL REVIEWER:</b>	Name: Leonard Linton Phone: 763 433-9834 Email: llinton@ci.ramsey.mn.us		

Covenant Meadows subdivision was approved and constructed in 2017. The Engineering Department reviewed and approved the plans for the project and provided inspection services during construction.

An adjacent resident was not happy about the project going in. Staff worked with him to try to address his concerns. The Developer also performed extra work to address his concerns.

Staff brought forward plans for reconstruction of Germanium Street which serves this area at the November 13, 2018 City Council meeting in a public hearing to consider approving the feasibility study for reconstruction of the streets in this area. The resident made statements that the drainage for Covenant Meadows was wrong and should not have been approved.

**Review of Drainage**

Staff has analyzed the pre-development and post development conditions related to the resident's lot. Two exhibits were prepared showing these conditions.

The pre-development conditions were 11.125 acres draining towards this property. The runoff for the 2, 10 and 100 year storms is 0, 0.1 and 3.1 cfs respectively.

The post-development conditions are 1.306 acres draining towards this property. The runoff for the 2, 10 and 100 year storms is 0, 0.02 and 0.75 cfs respectively.

The Covenant Meadows project intercepted 9.819 acres of runoff and directed it to two stormwater ponds constructed on the site. The ponds were designed to hold back to back 100 year storms, with the net effect that there would not be runoff from the site for the 100 year storm.

*Review File: Covenant Meadows  
Resident Drainage Concerns  
Engineering Review  
December 11, 2018  
Page 2 of 2*

Staff also prepared an Existing Residence Detail Map. The backyard is extremely flat and was not modified by the new project. A permit was not obtained for constructing the garage at the back of the property. The access road for the garage was dedicated right-of-way, it was not paved so water would infiltrate after a rain event. The road was most likely lower than the adjacent property so water would pool there rather than on the lot.

The new road was designed to drain from the new development to Germanium Street. Grades were raised to meet the minimum slope required by City Code for new streets. The outer edges of the ditches were probably raised above the existing grades. It may be possible to check the capacity of the ditches and lower the outside edge to provide drainage from the lot to the ditch.

**Public Works Committee**

6. 2.

**Meeting Date:** 12/18/2018

**By:** Bruce Westby, Engineering/Public  
Works

---

**Title:**

Staff Updates on Improvement Projects and Items of Interest

**Purpose/Background:**

**Purpose/Background:**

The purpose of this case is to update the Public Works Committee on current and proposed improvement projects within the City, and on other items of interest to the Committee.

**City Improvement Projects**

- **Riverdale Drive Extension - Traprock St. to Ramsey Blvd. (#16-20)**
  - Construction complete
  - Only punch list items remain
  - Final payment in 2019
- **River's Bend Street Reconstructions (#17-02)**
  - Construction complete
  - Only punch list items remain
  - Final payment in 2019
- **Puma Street Utilities Extensions (#17-10)**
  - Construction complete
  - Only punch list items remain
  - Final payment in 2019
- **Stanhope Terrace Street Reconstructions (#18-00)**
  - Construction complete
  - Only punch list items remain
  - Final payment in 2019
- **2018 Street Overlay Improvements (#18-03)**
  - Construction complete
  - Only punch list items remain
  - Final payment 2019
- **Bunker Lake Boulevard and Puma Street Improvements (#18-05)**
  - Construction complete
  - Only punch list items remain
  - Potential intersection control modifications required per PWC direction
  - Final completion 2019
- **The COR Regional Infiltration Basin (#18-09)**
  - Plans & Specifications nearly complete
  - Excess fill to be placed in The COR
  - Acquiring property for west end pond/road extension needs
  - LRRWMO Board approved permit extension to September 30, 2019
  - Construction proposed for spring/summer 2019
- **Riverdale Drive Trunk Utility Improvements (#18-14)**
  - Bids advertised
  - Bid opening January 15, 2019
  - Council to consider accepting bids and awarding contract January 22, 2019
  - Final completion 2019

## Anoka County Improvement Projects

- **Foley Boulevard/CSAH 11 Grade Separation @ BNSF Railway Crossing**
  - Project is currently unfunded

## MnDOT Improvement Projects

- **Ferry Street / Trunk Highway 47 Grade Separation @ BNSF Railway Crossing (2017)**
  - Preliminary design on hold
  - Exploring realignment of Highway 47 to remove S-curve at fair grounds
  - Ramsey Staff continues to track this project
  - MnDOT considering combining with other Highway 10 improvements

## Items of Interest

- **January Public Works Committee meeting cancelled**
  - Conflicts with the street maintenance funding open house with Board, Commission, Committee and Council members.

### **Timeframe:**

Staff estimates 5 minutes will be needed for updates and discussion.

### **Observations/Alternatives:**

N/A

### **Funding Source:**

N/A

### **Recommendation:**

N/A

### **Action:**

No formal action required. For Committee review and discussion purposes only.

---

## **Attachments**

*No file(s) attached.*

---

## **Form Review**

<b>Inbox</b>	<b>Reviewed By</b>	<b>Date</b>
Grant Riemer	Grant Riemer	12/13/2018 08:32 AM
Kurt Ulrich	Kurt Ulrich	12/13/2018 03:54 PM
Form Started By: Bruce Westby		Started On: 12/11/2018 10:35 AM
Final Approval Date: 12/13/2018		

**Public Works Committee**

**6.3.**

**Meeting Date:** 12/18/2018

**By:** Bruce Westby, Engineering/Public Works

**Title:**

Review Future Topics Calendar

**Purpose/Background:**

Attached is a calendar of future topics for review and discussion by the Public Works Committee. The calendar includes topics drawn from Committee requests received during meetings and/or unresolved topics previously discussed by the Committee. Calendar dates are estimated based on availability of information, staff workload and competing interests and objectives. Dates are therefore subject to change.

**Timeframe:**

Staff estimates 5 minutes will be necessary to review the future topics calendar and address questions.

**Observations/Alternatives:**

N/A

**Funding Source:**

N/A

**Recommendation:**

N/A

**Action:**

No formal action required. For Committee review and discussion purposes only.

**Attachments**

PWC Calendar Dec2018

**Form Review**

Inbox	Reviewed By	Date
Grant Riemer	Grant Riemer	12/13/2018 01:35 PM
Kurt Ulrich	Kurt Ulrich	12/13/2018 03:54 PM
Form Started By: Bruce Westby		Started On: 12/11/2018 10:36 AM
Final Approval Date: 12/13/2018		

## **Public Works Committee Future Topics Calendar \***

<b>Date</b>	<b>Topics for Discussion – Committee Action</b>
February 2019	Sunfish Lake Sedimentation Basin Improvements ( <i>Westby</i> )
March 2019	Gibbon Street Basement Flooding Funding Options ( <i>Westby</i> )
Future/TBD	Well Siting Study - Well #9 ( <i>Westby</i> )
Future/TBD	Sunwood Drive Roundabout Landscaping ( <i>Riemer</i> )
Future/TBD	County Ditch Maintenance / Buffer Law ( <i>Westby</i> )
<b>Date</b>	<b>Topics for Discussion – Regulatory</b>
Future/TBD	Sunfish Lake Boulevard Speed Zone Study Results ( <i>Westby</i> )
February 2019	Wellhead Protection Plan Update ( <i>Westby</i> )
<b>Date</b>	<b>Topics for Discussion – Policy</b>
Future/TBD	Landscaped Median Maintenance Policy ( <i>Riemer</i> )
March 2019	Draft Trail Maintenance Policy ( <i>Westby</i> )
May 2019	Draft Stormwater Pond Maintenance Policy ( <i>Westby</i> )
<b>Date</b>	<b>Topics for Discussion – Planning and Budget</b>
March 2019	Municipal State Aid System (MSAS) Revisions ( <i>Westby</i> )
April 2019	Review 1996 and 2007 (unadopted) TH 47 Corridor Studies ( <i>Westby</i> )
Future/TBD	Public Works Facility Review/Update ( <i>Riemer</i> )
Future/TBD	Long-Term Water Supply Plan ( <i>Westby</i> )
<b>Date</b>	<b>Topics for Discussion – Staff Updates</b>
February 2019	Water Conservation Opportunities / Incentives ( <i>Westby</i> )
Future/TBD	Asset Management Program ( <i>Westby</i> )

\* Dates are estimated and are subject to change based on availability of information, staff workload, and competing objectives.