



Storage building location
7633 161st Ave. NW

Side setback from
property line = 45 ft.

Existing access

Distance from 161st
roadway = 500 ft.

Storage building setback
minimum:
60 feet from centerline of
road right-of-way + 20' for
Side yard on corner lot.
(40' from property line)

St. Katharine Drexel
Storage Building

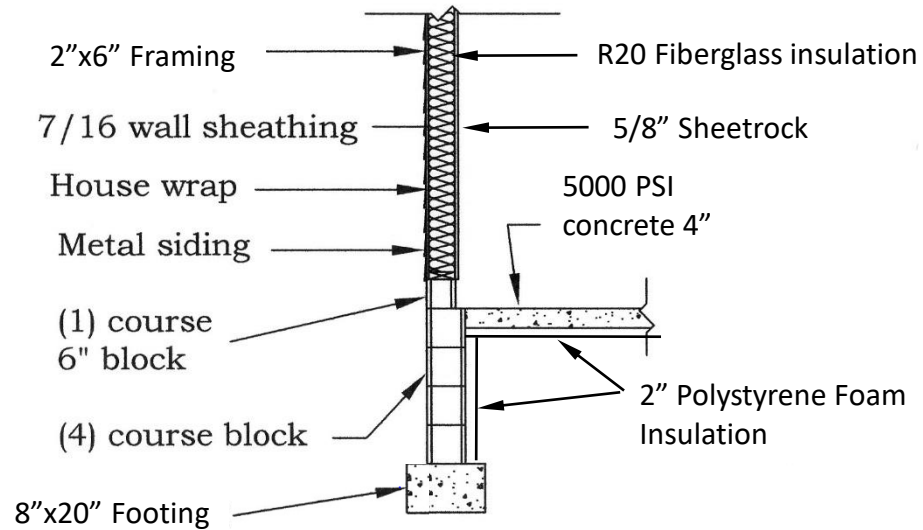

Foundation with slab

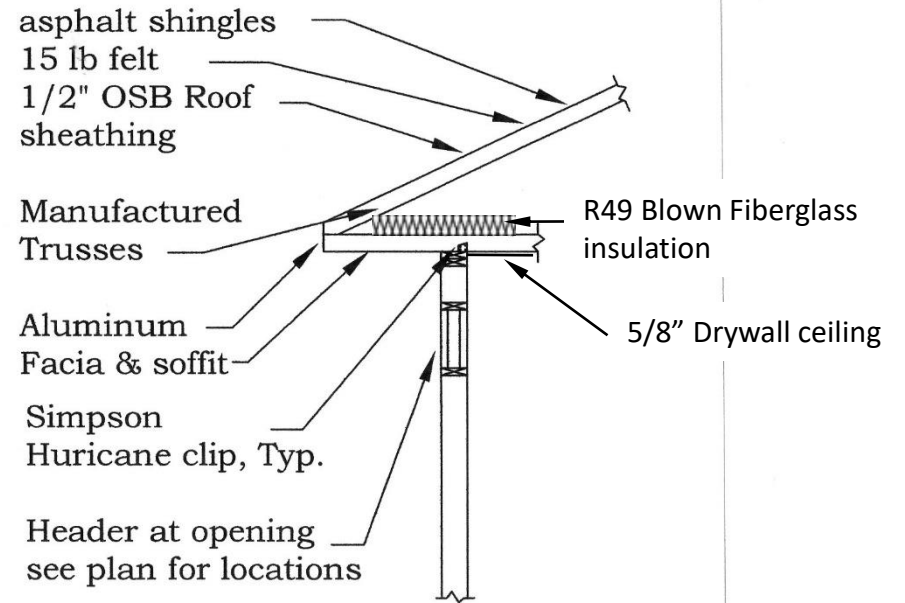

Typical Truss 2x6 Bearing

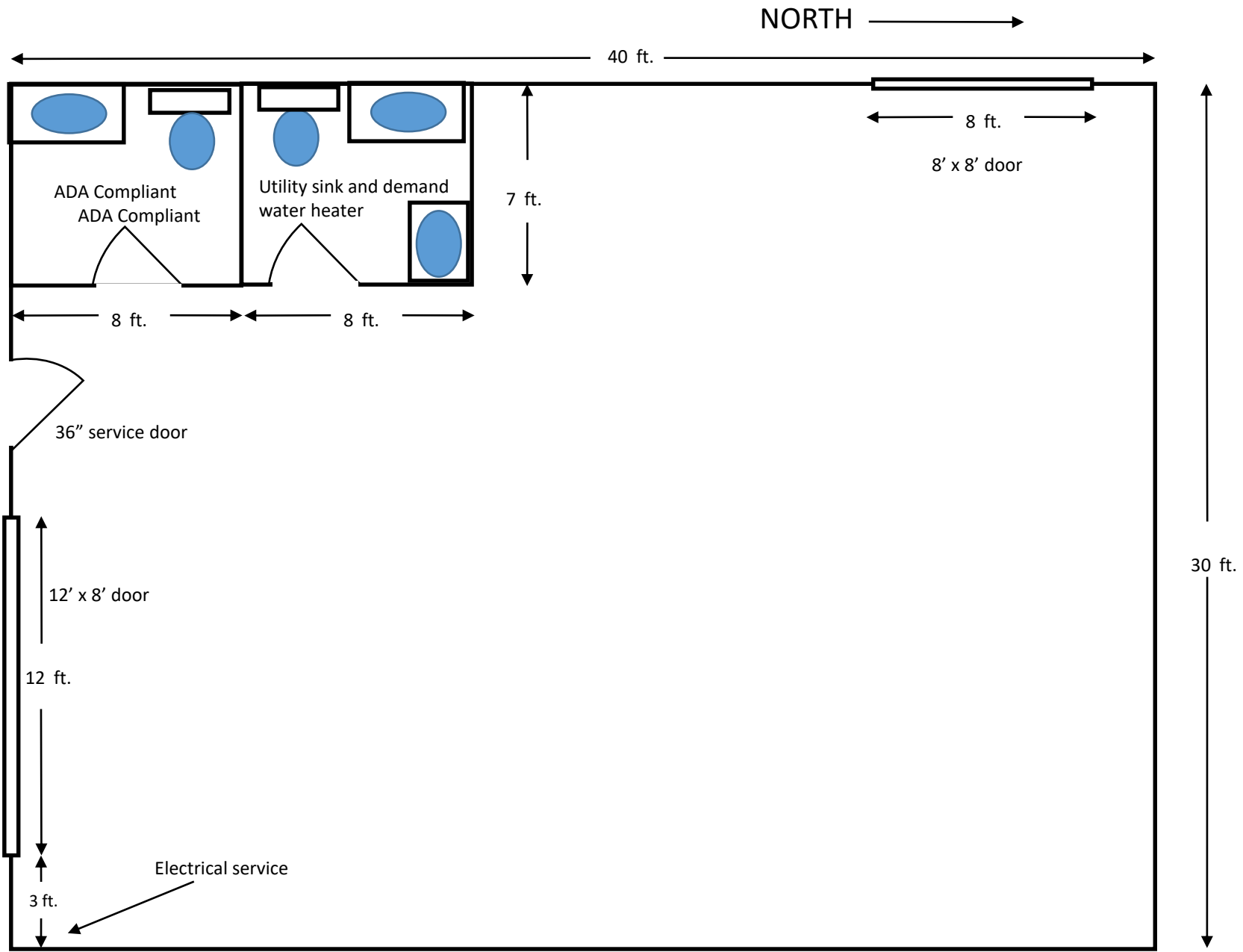



Measurement



| Feet (US) ▼

Measurement Result

7.31 Feet (US)

Clear

St Katharine Drexel Storage Building

Storage Building

St. Katharine Drexel

Ramsey MN.

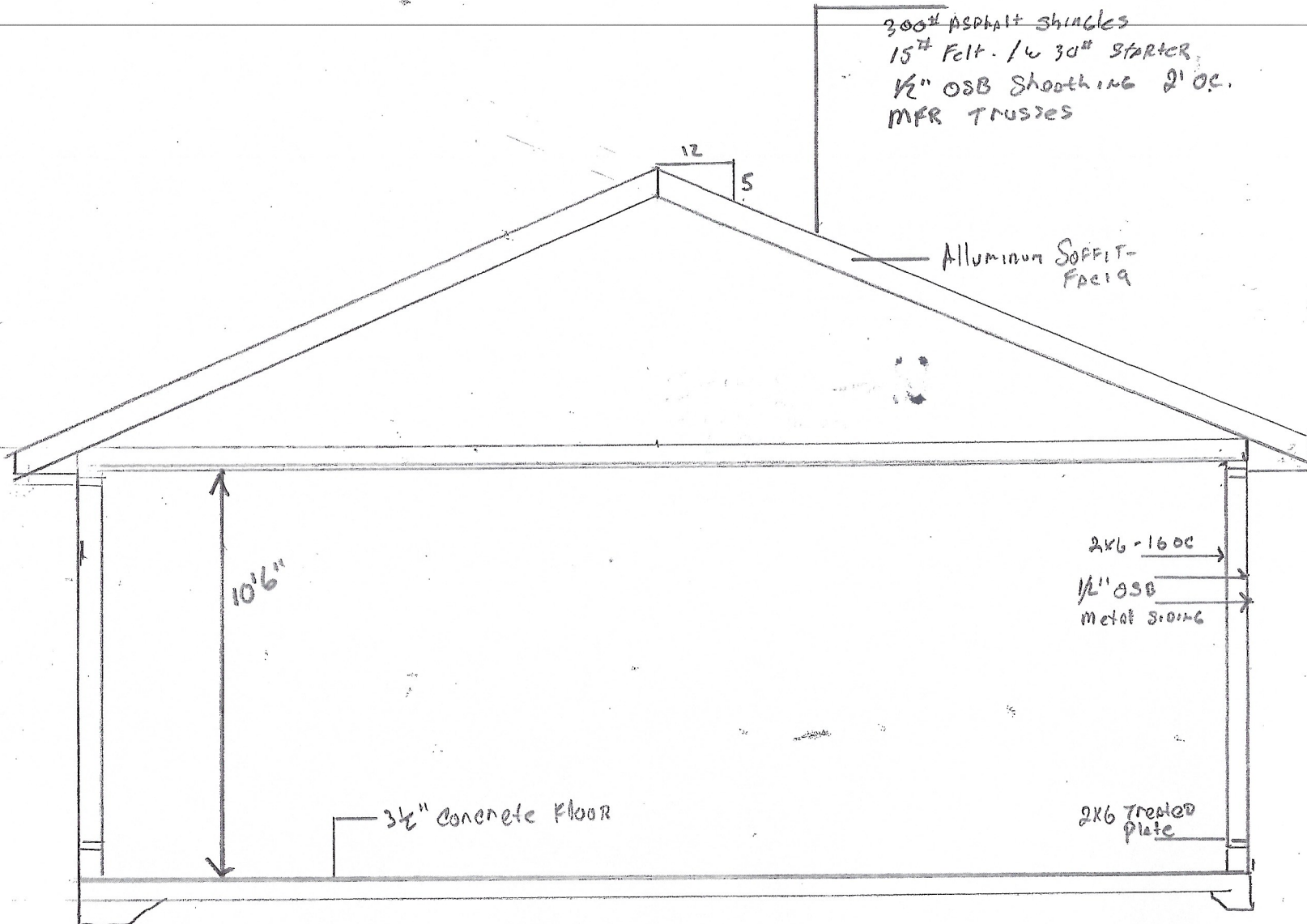

Storage Buildings

St. Katharine Drexel

Ramsey, MN.

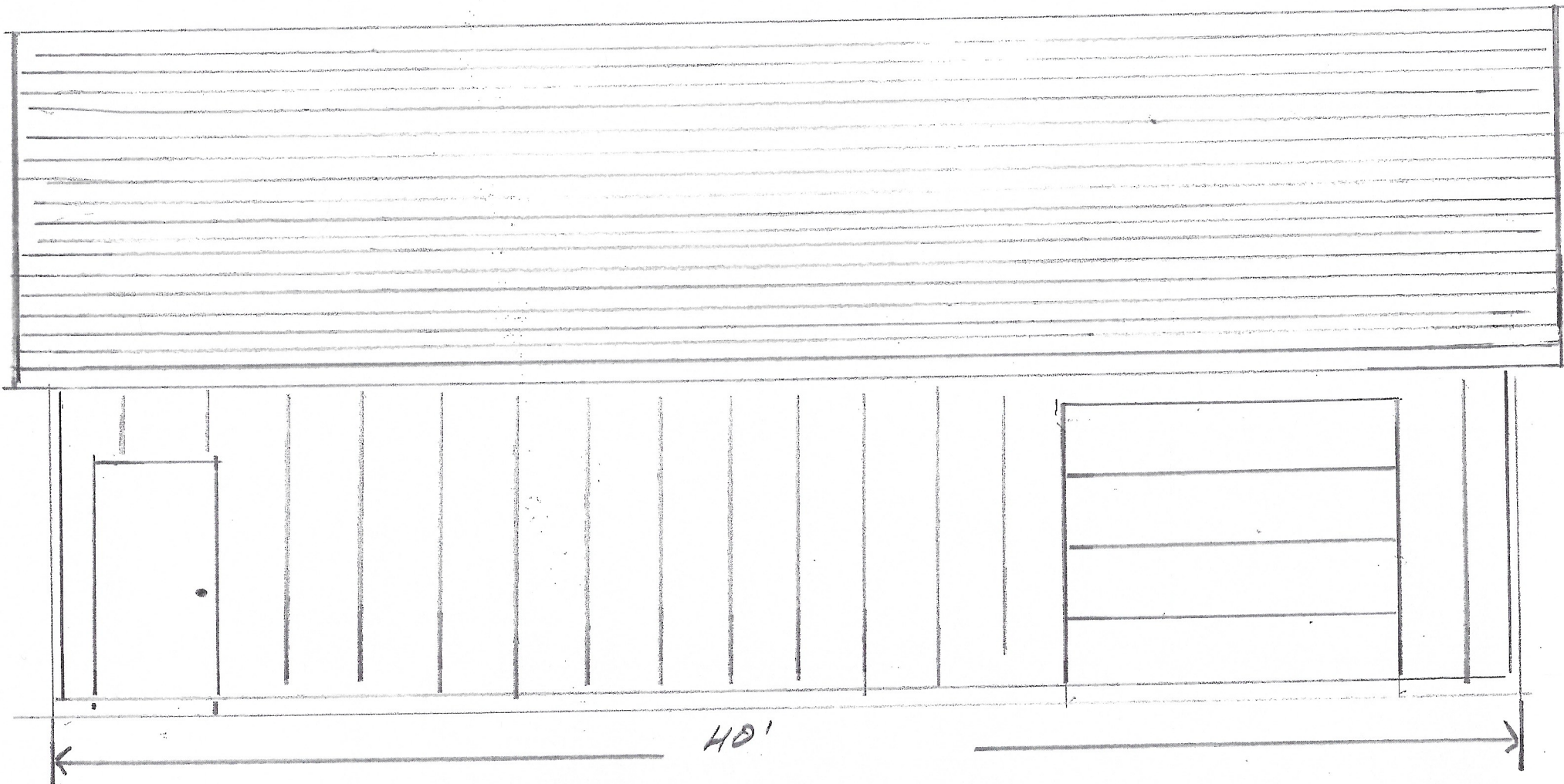

Storage Building

St Katharine Drexel

Ramsey, MN

