

LEGAL DESCRIPTION

PARCEL DESCRIPTION: (Per Schedule A of Title Commitment File No. 2651, with a commitment date of October 17, 2019 at 7:00 am, prepared Twin City Title Company, LLC as issuing agent for Old Republic National Title Insurance Company)

Parcel A: Outlot B, Pearson Place, Anoka County, Minnesota.





Parcel B: That part of the Northwest Quarter of the Northwest Quarter of Section 29, Township 32, Range 25, Anoka County, Minnesota, lying southerly of U.S. Highway 10 and 169.

Parcel C: Lot 2, Block 3, Pearson Place, Anoka County, Minnesota.

Parcel D: Lot 1, Block 3, Pearson Place, Anoka County, Minnesota.

(abstract property)

LEGEND

-  OPEN SPACE
-  OPEN SPACE - WOODED
-  STORMWATER POND
-  INFILTRATION BASIN

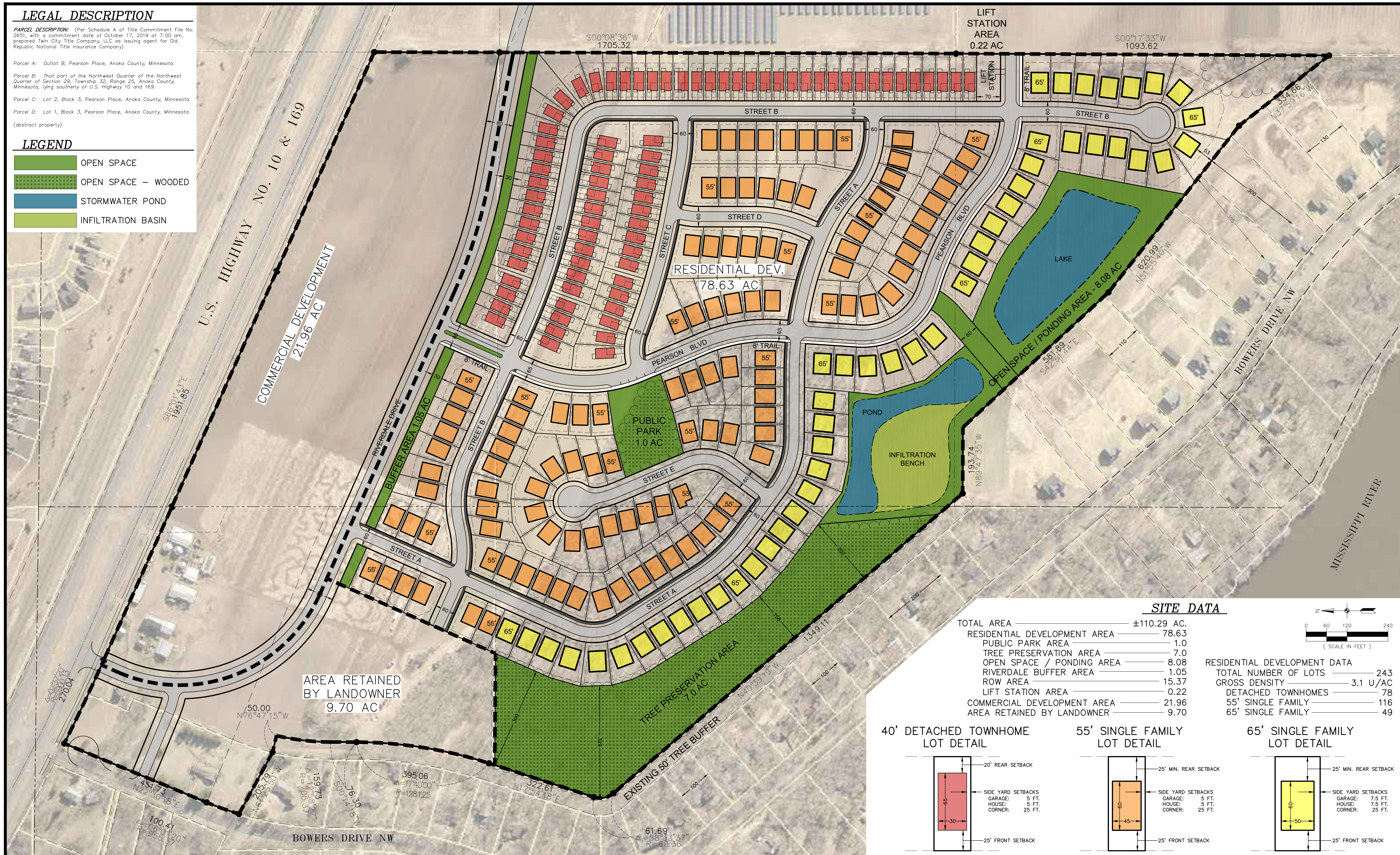

SITE DATA

TOTAL AREA	±110.29 AC.
RESIDENTIAL DEVELOPMENT AREA	78.63
PUBLIC PARK AREA	1.0
TREE PRESERVATION AREA	7.0
OPEN SPACE / PONDING AREA	8.08
RIVERDALE BUFFER AREA	1.05
ROW AREA	15.37
LIFT STATION AREA	0.22
COMMERCIAL DEVELOPMENT AREA	21.96
AREA RETAINED BY LANDOWNER	9.70

RESIDENTIAL DEVELOPMENT DATA

TOTAL NUMBER OF LOTS	243
GROSS DENSITY	3.1 U/AC
DETACHED TOWNHOMES	78
55' SINGLE FAMILY	116
65' SINGLE FAMILY	49

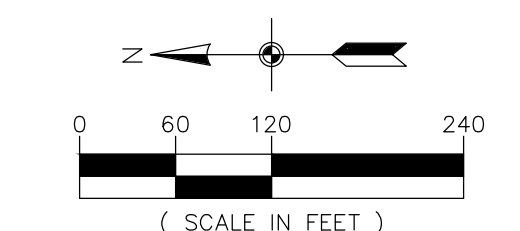

40' DETACHED TOWNHOME LOT DETAIL

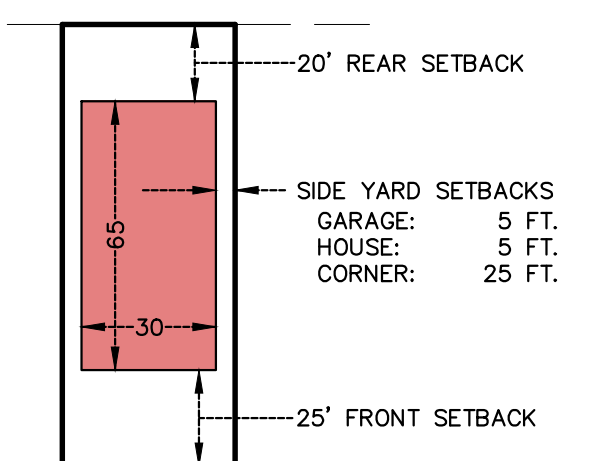

55' SINGLE FAMILY LOT DETAIL

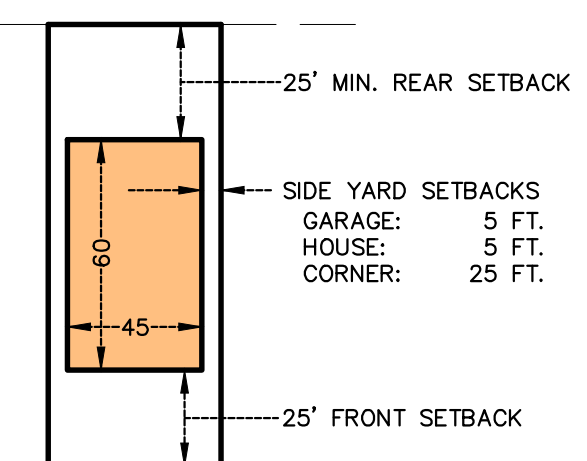

65' SINGLE FAMILY LOT DETAIL

