

RIVERSTONE SOUTH

CITY OF RAMSEY
COUNTY OF ANOKA
SECS. 29 & 30, TWP. 32, RGE. 25

KNOW ALL PERSONS BY THESE PRESENTS: That Pearson Properties of Ramsey, LLC, a Minnesota limited liability company, owner of the following described property:

Outlot B, PEARSON PLACE, Anoka County, Minnesota.

and

That part of the Northwest Quarter of the Northwest Quarter of Section 29, Township 32, Range 25, Anoka County, Minnesota, lying southerly of U.S. Highway 10 and 169.

And that Alan R. Pearson, Trustee of the Alan R. Pearson Revocable Trust under agreement dated April 7, 2005, owner of the following described property:

Lot 2, Block 3, PEARSON PLACE, Anoka County, Minnesota.

And that Elizabeth J. Pearson, Trustee of the Elizabeth J. Pearson Trust under agreement dated April 7, 2005, owner of the following described property:

Lot 1, Block 3, PEARSON PLACE, Anoka County, Minnesota.

Have caused the same to be surveyed and platted as RIVERSTONE SOUTH and do hereby dedicate to the public for public use the public ways and the drainage and utility easements as shown on this plat.

In witness whereof said Pearson Properties of Ramsey, LLC, a Minnesota limited liability company, has caused these presents to be signed by its proper officer this ____ day of _____, 20____.

PEARSON PROPERTIES OF RAMSEY, LLC

Alan R. Pearson, President

STATE OF _____
COUNTY OF _____

This instrument was acknowledged before me on _____ by Alan R. Pearson, President of Pearson Properties of Ramsey, LLC, a Minnesota limited liability company, on behalf of the company.

(Signed)

(Printed)
Notary Public, _____
My commission expires _____

In witness whereof said Alan R. Pearson, Trustee of the Alan R. Pearson Revocable Trust under agreement dated April 7, 2005 has hereunto set his hand this ____ day of _____, 20____.

ALAN R. PEARSON TRUSTEE OF THE
ALAN R. PEARSON REVOCABLE TRUST
UNDER AGREEMENT DATED APRIL 7, 2005

Alan R. Pearson, Trustee

STATE OF _____
COUNTY OF _____

This instrument was acknowledged before me on _____ by Alan R. Pearson, Trustee of the Alan R. Pearson Revocable Trust under agreement dated April 7, 2005.

(Signed)

(Printed)
Notary Public, _____
My commission expires _____

In witness whereof said Elizabeth J. Pearson, Trustee of the Alan R. Pearson Revocable Trust under agreement dated April 7, 2005 has hereunto set his hand this ____ day of _____, 20____.

ELIZABETH J. PEARSON TRUSTEE OF THE
ALAN R. PEARSON REVOCABLE TRUST
UNDER AGREEMENT DATED APRIL 7, 2005

Elizabeth J. Pearson, Trustee

STATE OF _____
COUNTY OF _____

This instrument was acknowledged before me on _____ by Elizabeth J. Pearson, Trustee of the Alan R. Pearson Revocable Trust under agreement dated April 7, 2005.

(Signed)

(Printed)
Notary Public, _____
My commission expires _____

In witness whereof Alan R. Pearson, Trustee of the Elizabeth J. Pearson Trust under agreement dated April 7, 2005 has hereunto set her hand this ____ day of _____, 20____.

ALAN R. PEARSON, TRUSTEE OF THE
ELIZABETH J. PEARSON TRUST UNDER
AGREEMENT DATED APRIL 7, 2005

Alan R. Pearson, Trustee

STATE OF _____
COUNTY OF _____

This instrument was acknowledged before me on _____ by Alan R. Pearson, Trustee of the Elizabeth J. Pearson Trust under agreement dated April 7, 2005.

(Signed)

(Printed)
Notary Public, _____
My commission expires _____

In witness whereof Elizabeth J. Pearson, Trustee of the Elizabeth J. Pearson Trust under agreement dated April 7, 2005 has hereunto set her hand this ____ day of _____, 20____.

ELIZABETH J. PEARSON, TRUSTEE OF THE
ELIZABETH J. PEARSON TRUST UNDER
AGREEMENT DATED APRIL 7, 2005

Elizabeth J. Pearson, Trustee

STATE OF _____
COUNTY OF _____

This instrument was acknowledged before me on _____ by Elizabeth J. Pearson, Trustee of the Elizabeth J. Pearson Trust under agreement dated April 7, 2005.

(Signed)

(Printed)
Notary Public, _____
My commission expires _____

I Thomas R. Balluff do hereby certify that this plat was prepared by me or under my direct supervision; that I am a duly Licensed Land Surveyor in the State of Minnesota; that this plat is a correct representation of the boundary survey; that all mathematical data and labels are correctly designated on this plat; that all monuments depicted on this plat have been, or will be correctly set within one year; that all water boundaries and wet lands, as defined in Minnesota Statutes, Section 505.01, Subd. 3, as of the date of this certificate are shown and labeled on this plat; and all public ways are shown and labeled on this plat.

Dated this ____ day of _____, 20____.

Thomas R. Balluff, Licensed Land Surveyor
Minnesota License No. 40361

STATE OF _____
COUNTY OF _____

This instrument was acknowledged before me on _____ by Thomas R. Balluff.

(Signed)

(Printed)
Notary Public, _____
My commission expires _____

CITY COUNCIL, CITY OF RAMSEY, MINNESOTA

This plat of RIVERSTONE SOUTH was approved and accepted by the City Council of the City of Ramsey, Minnesota at a regular meeting thereof held this ____ day of _____, 20____, and said plat is in compliance with the provisions of Minnesota Statutes, Section 505.03, Subd. 2.

CITY COUNCIL, CITY OF RAMSEY, MINNESOTA

By: _____, Mayor

By: _____, Clerk

COUNTY SURVEYOR

I hereby certify that in accordance with Minnesota Statutes, Section 505.021, Subd. 11, this plat has been reviewed and approved this ____ day of _____, 20____.

By: _____
David M. Zieglmeier
Anoka County Surveyor

COUNTY AUDITOR/TREASURER

Pursuant to Minnesota Statutes, Section 505.021, Subd. 9, taxes payable in the year 20____ on the land hereinbefore described have been paid. Also, pursuant to Minnesota Statutes, Section 272.12, there are no delinquent taxes and transfer entered this ____ day of _____, 20____.

Property Tax Administrator

By: _____, Deputy

COUNTY RECORDER/REGISTRAR OF TITLES

County of Anoka, State of Minnesota

I hereby certify that this plat of RIVERSTONE SOUTH was filed in the office of the County Recorder/Registrar of Titles for public record on this day of _____, 20____, at ____ o'clock ____M. and was duly recorded as Document Number _____.

County Recorder/Registrar of Titles

By: _____, Deputy



RIVERSTONE SOUTH

CITY OF RAMSEY
COUNTY OF ANOKA
SECS. 29 & 30, TWP. 32, RGE. 25

RIVER CROSSING ADDITION

SECTION 29, TOWNSHIP 32, RANGE 25

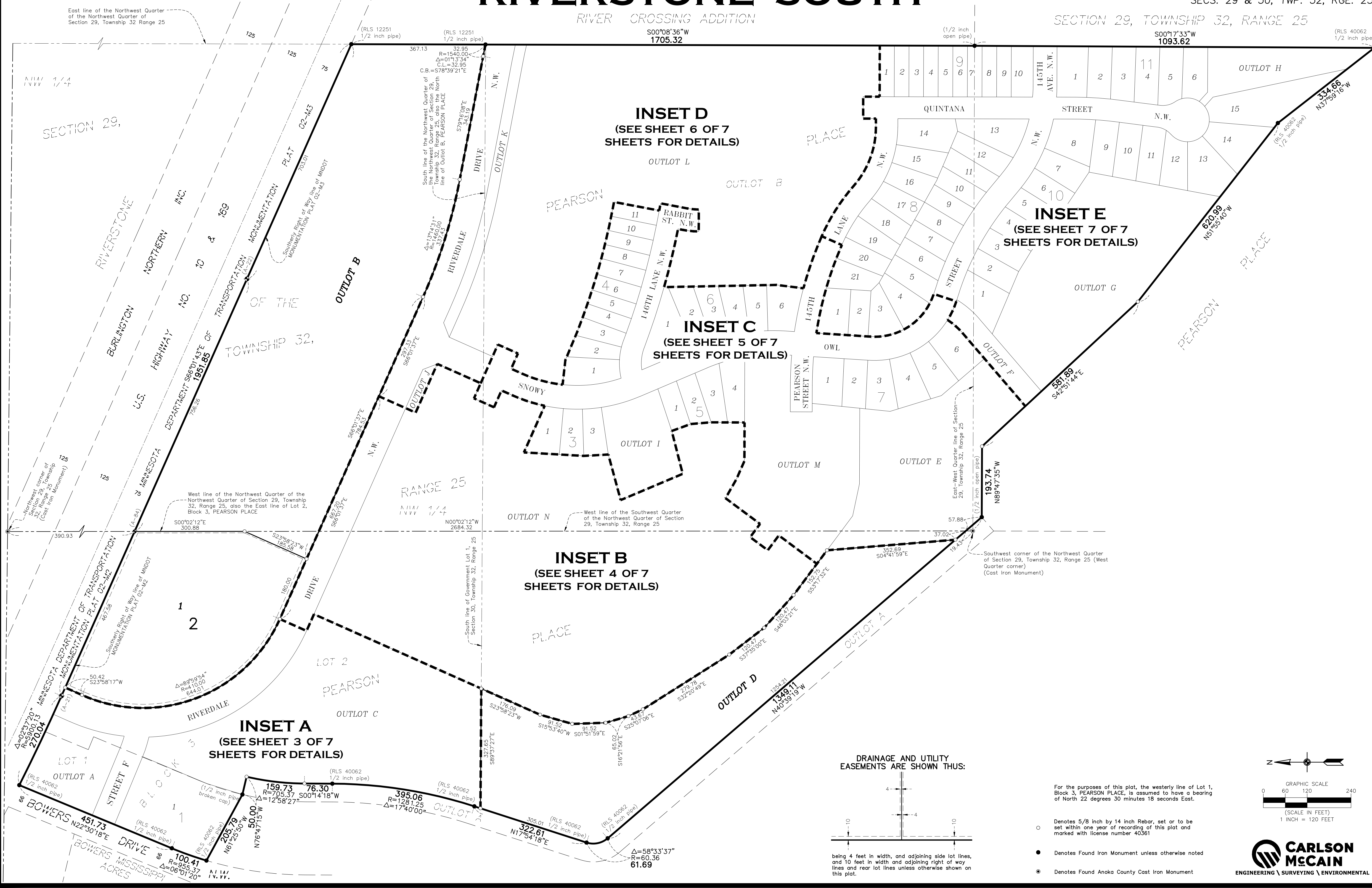

INSET D
(SEE SHEET 6 OF 7 SHEETS FOR DETAILS)

INSET C
(SEE SHEET 5 OF 7 SHEETS FOR DETAILS)

INSET E
(SEE SHEET 7 OF 7 SHEETS FOR DETAILS)

INSET B
(SEE SHEET 4 OF 7 SHEETS FOR DETAILS)

INSET A
(SEE SHEET 3 OF 7 SHEETS FOR DETAILS)

DRAINAGE AND UTILITY EASEMENTS ARE SHOWN THUS:

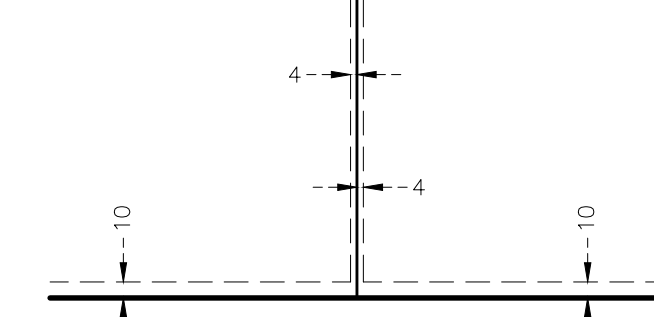

being 4 feet in width, and adjoining side lot lines, and 10 feet in width and adjoining right of way lines and rear lot lines unless otherwise shown on this plot.

For the purposes of this plot, the westerly line of Lot 1, Block 3, PEARSON PLACE, is assumed to have a bearing of North 22 degrees 30 minutes 18 seconds East.

- Denotes 5/8 inch by 14 inch Rebar, set or to be set within one year of recording of this plot and marked with license number 40361
- Denotes Found Iron Monument unless otherwise noted
- ⊙ Denotes Found Anoka County Cast Iron Monument

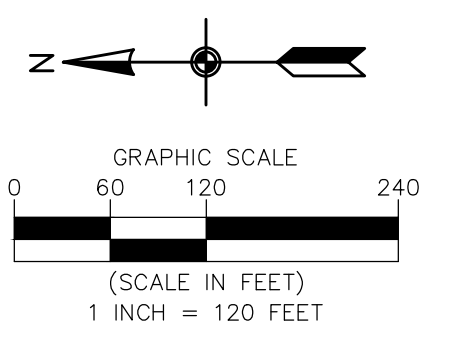

CARLSON MCCAIN
ENGINEERING \ SURVEYING \ ENVIRONMENTAL

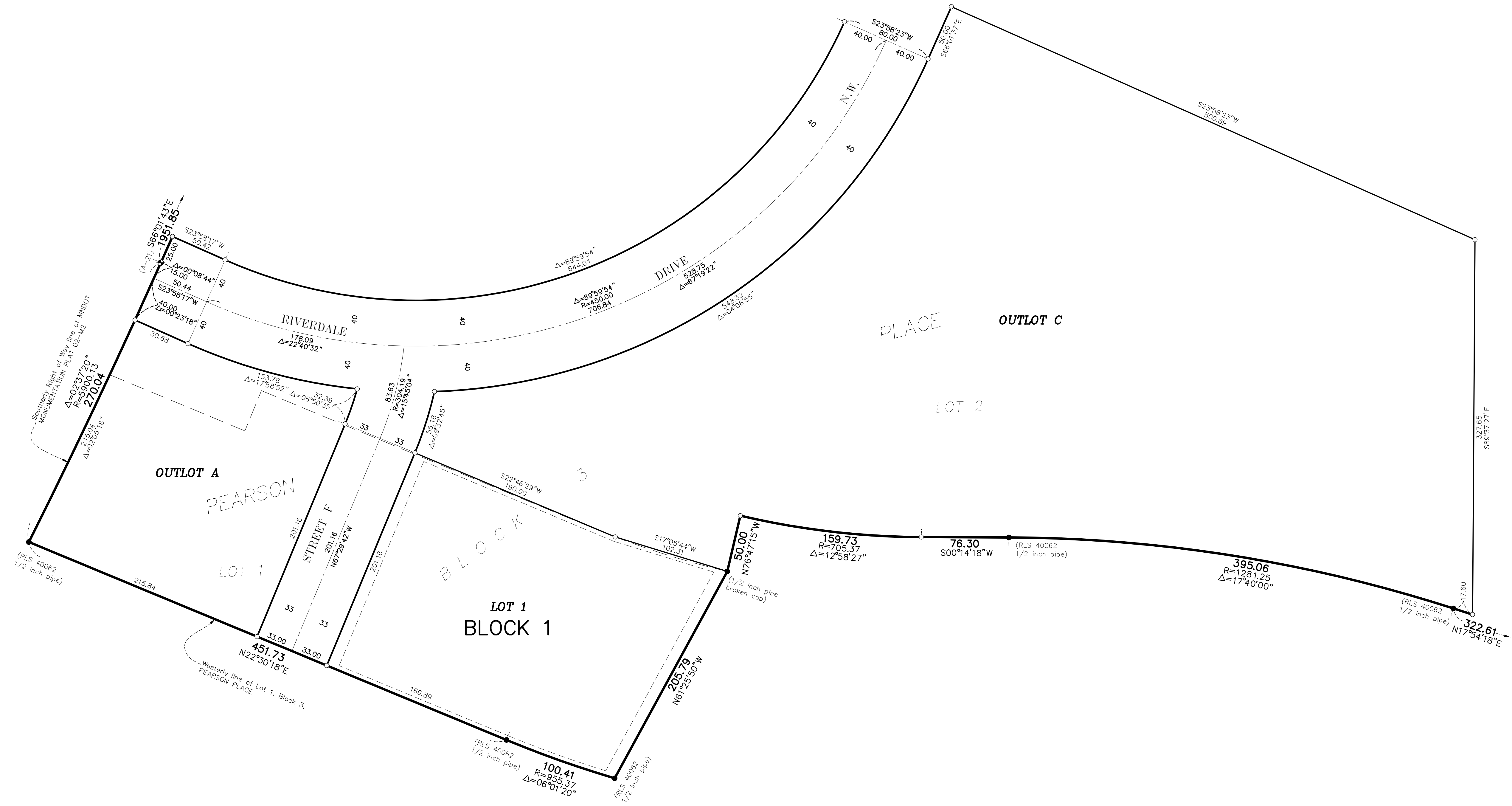

DRAINAGE AND UTILITY EASEMENTS ARE SHOWN THUS:

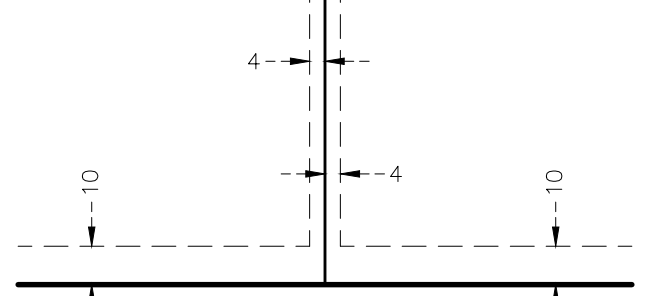

being 4 feet in width, and adjoining side lot lines, and 10 feet in width and adjoining right of way lines and rear lot lines unless otherwise shown on this plat.

For the purposes of this plat, the westerly line of Lot 1, Block 3, PEARSON PLACE, is assumed to have a bearing of North 22 degrees 30 minutes 18 seconds East.

- ◆ Denotes 3/4 inch Minnesota Department of Transportation Iron Pin
- Denotes 5/8 inch by 14 inch Rebar, set or to be set within one year of recording of this plat and marked with license number 40361
- Denotes Found Monument as noted

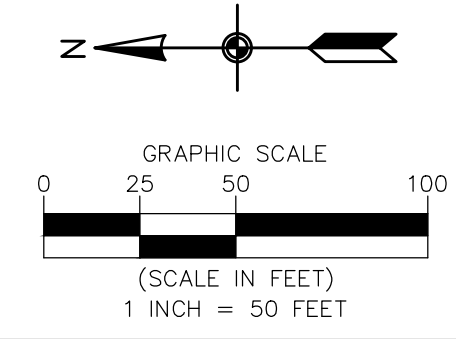

INSET D

CITY OF RAMSEY
 COUNTY OF ANOKA
 SECS. 29 & 30,
 TWP. 32, RGE. 25

S00°08'36"W
 -1705.32-

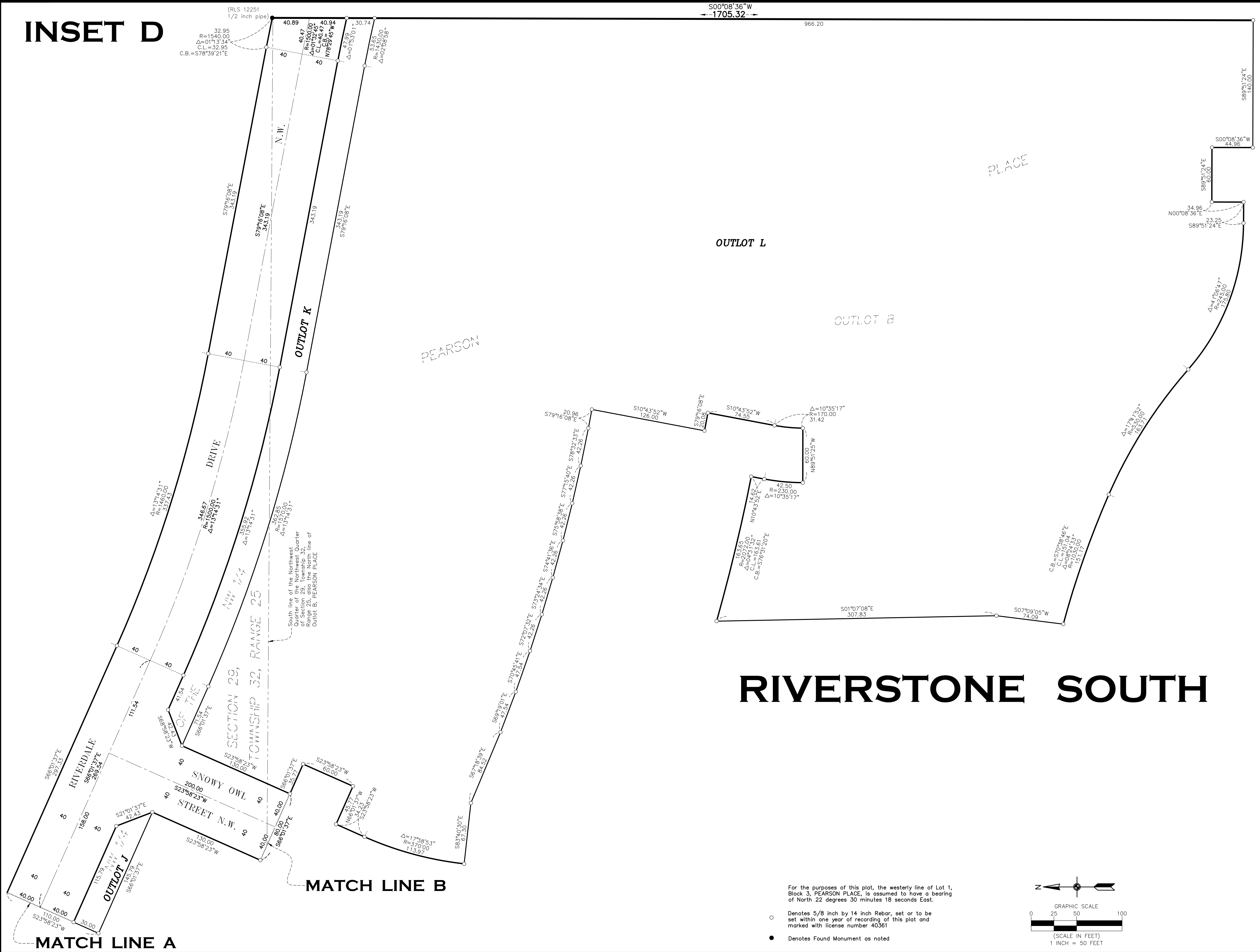

RIVERSTONE SOUTH

For the purposes of this plat, the westerly line of Lot 1, Block 3, PEARSON PLACE, is assumed to have a bearing of North 22 degrees 30 minutes 18 seconds East.

○ Denotes 5/8 inch by 14 inch Rebar, set or to be set within one year of recording of this plat and marked with license number 40361

● Denotes Found Monument as noted

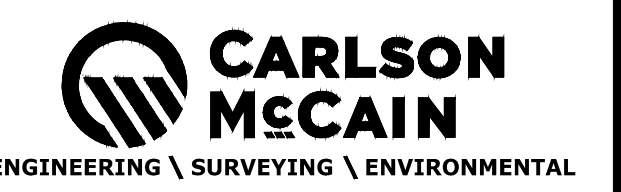
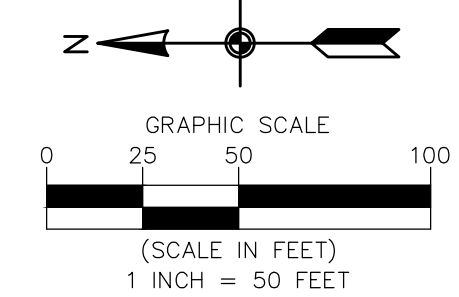

INSET E

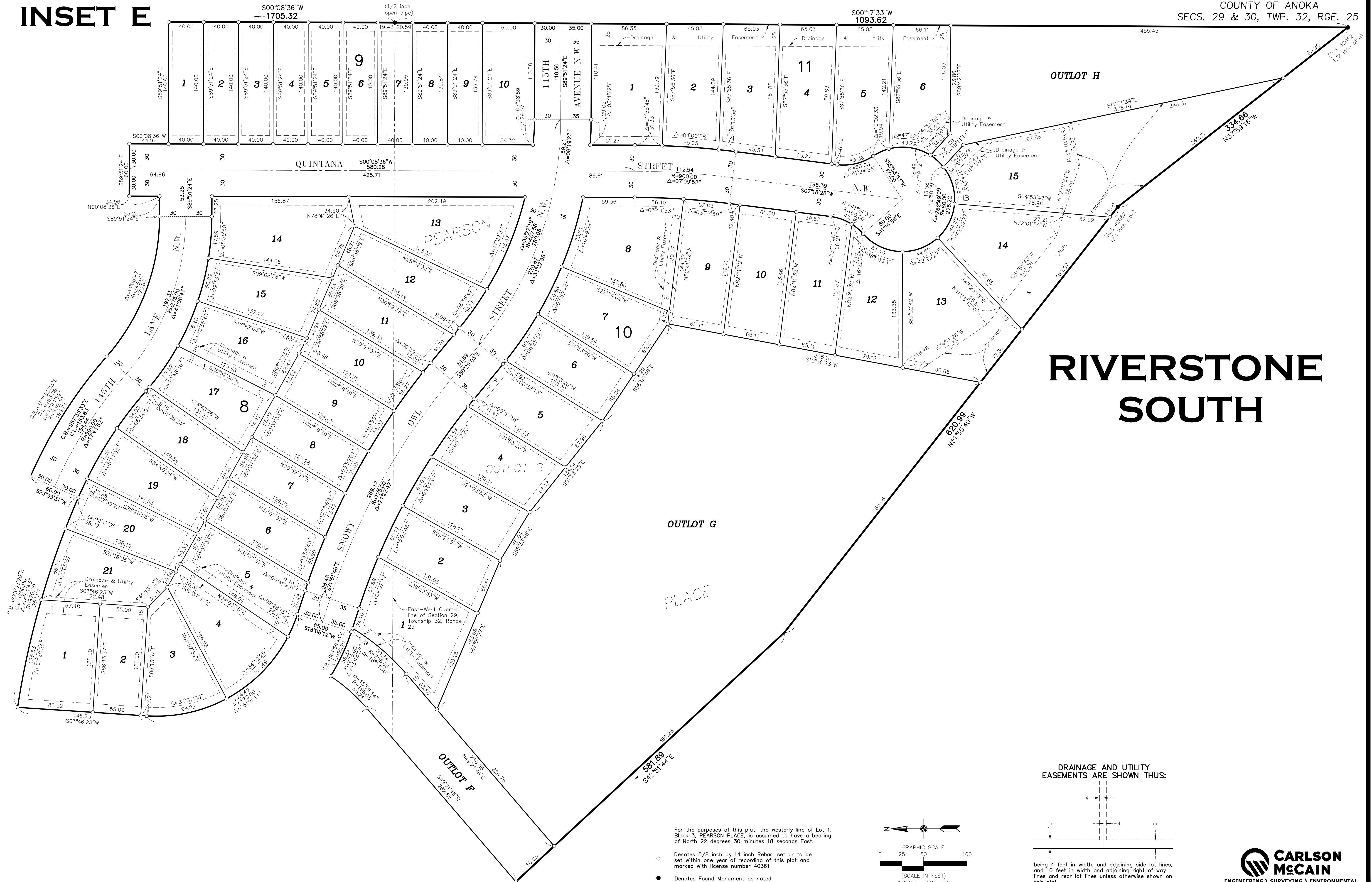

RIVERSTONE SOUTH

For the purposes of this plat, the westerly line of Lot 1, Block 3, PEARSON PLACE, is assumed to have a bearing of North 22 degrees 30 minutes 18 seconds East.

- Denotes 5/8 inch by 14 inch Rebar, set or to be set within one year of recording of this plat and marked with license number 40361
- Denotes Found Monument as noted

