

CITY OF RAMSEY

WETLAND 114P OUTLET MODIFICATIONS

CITY IMPROVEMENT PROJECT NO. 19-07

GOVERNING SPECIFICATIONS

THE 2020 EDITION OF THE MINNESOTA DEPARTMENT OF TRANSPORTATION "STANDARD SPECIFICATIONS FOR CONSTRUCTION" SHALL GOVERN.

ALL FEDERAL, STATE AND LOCAL LAWS, REGULATIONS AND ORDINANCES SHALL BE COMPLIED WITH IN THE CONSTRUCTION OF THIS PROJECT.

ALL TRAFFIC CONTROL DEVICES AND SIGNING SHALL CONFORM TO THE MINNESOTA MANUAL ON UNIFORM TRAFFIC CONTROL DEVICES, INCLUDING THE FIELD MANUAL FOR TEMPORARY TRAFFIC CONTROL ZONE LAYOUTS.

SHEET INDEX

THIS PLAN CONTAINS 5 SHEETS

SHEET No.	DESCRIPTION
1	TITLE SHEET
2	STATEMENT OF ESTIMATED QUANTITIES / DETAIL SHEET
3	EXISTING CONDITIONS
4	OUTLET CONTROL STRUCTURE PLAN, PROFILE AND DETAIL
5	SANITARY MANHOLE CASTING ADJUSTMENTS
6	SANITARY MANHOLE CASTING ADJUSTMENTS

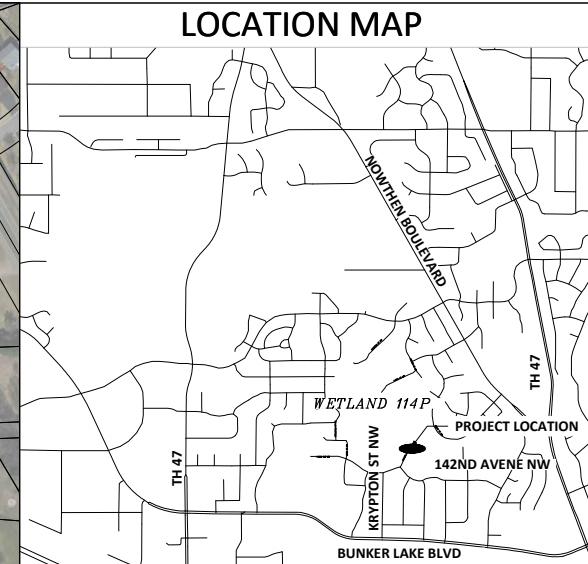
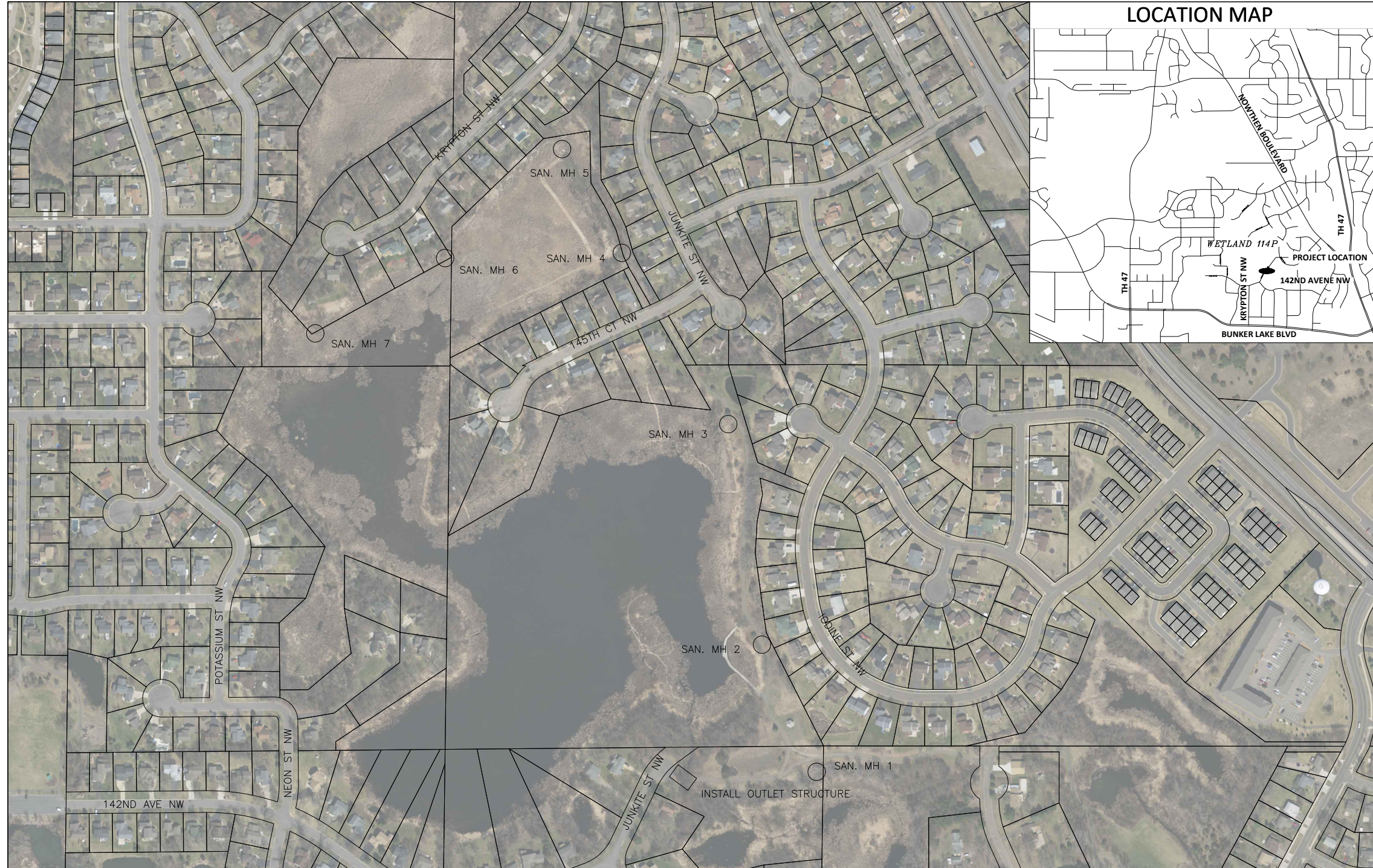

LEGEND

	LIGHT POLE		EASEMENT
	TREE		RIGHT OF WAY
	TREE		ELECTRIC
	SHRUB		OVERHEAD ELECTRIC
	SIGN		GAS
	VALVE		TELECOMMUNICATIONS
	UTILITY PEDESTAL		STORM SEWER
	HAND HOLE		SANITARY SEWER
	REMOVE TREE		WATERMAIN
	3'x2' CATCH BASIN		SAWCUT PAVEMENT
	MANHOLE		TREE LINE
	INLET PROTECTION		FENCE
	HYDRANT		LANDSCAPING
	VALVE		RETAINING WALL
			5' CONTOUR LINE
			1' CONTOUR LINE

I hereby certify that this plan, specification, or report was prepared by me or under my direct supervision and that I am a duly Licensed Professional Engineer under the laws of the State of Minnesota.

LEONARD LINTON, P.E.
CITY OF RAMSEY

21112 DATE 12/08/22
LIC. NO.

DATE	REVISION

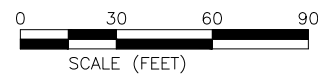

CITY OF RAMSEY
7550 SUNWOOD DRIVE
RAMSEY, MN 55303
(763) 427-1410 FAX (763) 433-9898

THE SUBSURFACE UTILITY INFORMATION IN THIS PLAN IS UTILITY QUALITY LEVEL D. THIS QUALITY LEVEL WAS DETERMINED ACCORDING TO THE GUIDELINES OF CI/ASCE 38-02, ENTITLED "STANDARD GUIDELINES FOR THE COLLECTION AND DEPICTION OF EXISTING SUBSURFACE UTILITY DATA."

NOTE: EXISTING UTILITY INFORMATION SHOWN ON THIS PLAN HAS BEEN PROVIDED BY THE UTILITY OWNER. THE CONTRACTOR SHALL FIELD VERIFY EXACT LOCATIONS PRIOR TO COMMENCING CONSTRUCTION AS REQUIRED BY STATE LAW. NOTIFY GOPHER STATE ONE CALL 1-800-252-1166 OR 651-454-0002



Call before you dig
811
651-454-0002 Metro
800-252-1166 Outstate
www.gopherstateonecall.org

Wetland 114P Outlet Improvements

Notes	Item No.	MnDOT No.	Item	Unit	Estimated Quantity
	1	2021.501	Mobilization	LS	1
2	2	2105.507	Common Excavation (EV)	CY	20
	3	2506.502	Construct 60" Outlet Structure	EA	1
	4	2506.502	Adjust Sanitary Casting, installing Chimney Seals	EA	6
	5	2506.502	Furnish and Install Haala PS60-72 Grate	EA	1
	6	2573.503	Silt Fence	LF	40
3	7	2574.507	Topsoil (LV)	CY	10
	8	2575.504	Hydroseed disturbed areas	SY	314

PAY ITEM NOTES:

1. REMOVAL LIMITS SHALL BE MARKED IN THE FIELD BY CITY STAFF.
2. EV TO CV CONVERSION FACTOR = 1.25.
3. LV TO CV CONVERSION FACTOR = 1.30.

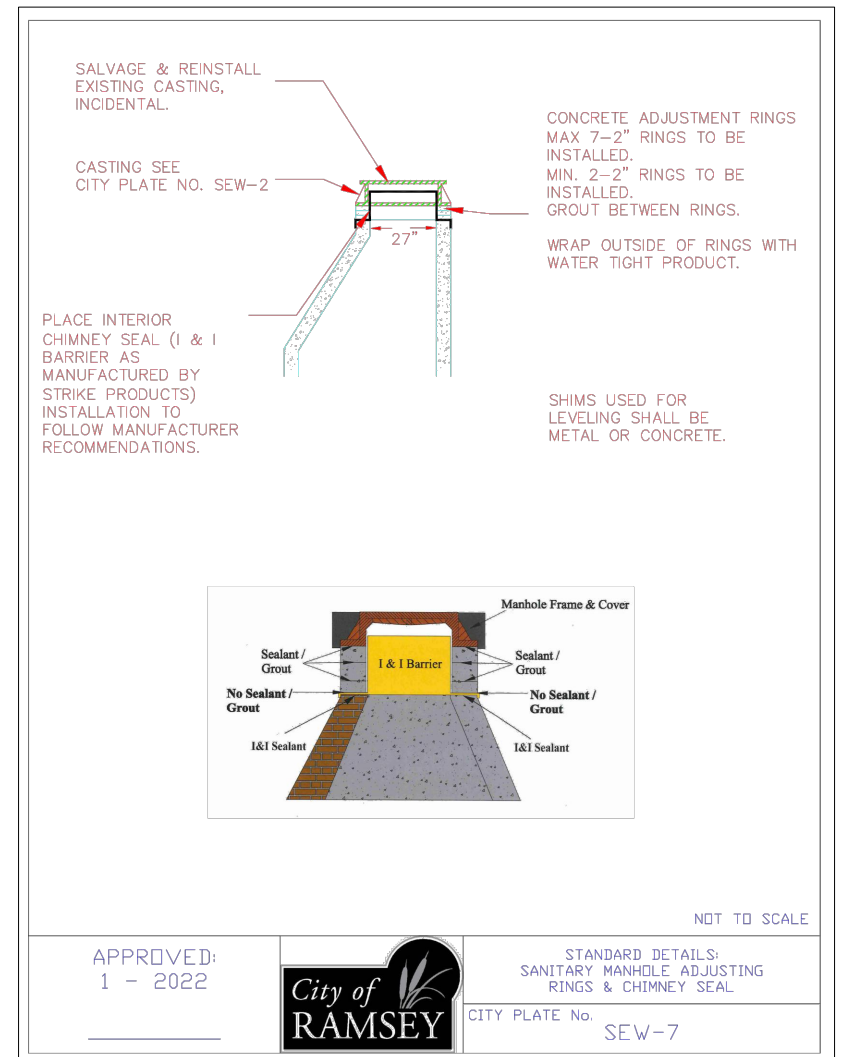

DATE	REVISION

I hereby certify that this plan, specification, or report was prepared by me or under my direct supervision and that I am a duly Licensed Professional Engineer under the laws of the State of Minnesota

Engineer
Date 12/08/22 Lic. No. 21112

DESIGNED BY:
LLL

DRAWN BY:
LLL DATE:
12/08/22

CHECKED BY:
LLL FILE No.
19-07

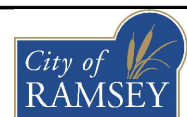

CITY OF RAMSEY
7550 SUNWOOD DRIVE
RAMSEY, MN 55303
(763) 427-1410 FAX (763) 433-9898

STATEMENT OF ESTIMATED QUANTITIES/ DETAIL SHEET

WETLAND 114P OUTLET MODIFICATIONS
CITY PROJECT NO. 19-07
CITY OF RAMSEY, MINNESOTA

26-32-25-44-0001
14260

26-32-25-44-0030
5455

JUNKITE STREET

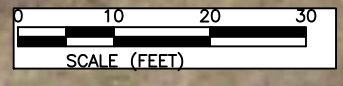

26-32-25-44-0005
14249

LEGEND

- EX. MAJOR CONTOUR
- EX. MINOR CONTOUR
- - - - - SILT FENCE
- EDGE OF PAVEMENT
- LOT LINE

NOTE:

1. PROTECT EXISTING TREE WHILE INSTALLING STRUCTURE.
2. INSTALL SILT FENCE DOWNSLOPE OF DISTURBED AREA BEFORE EXCAVATING.

DATE	REVISION

I hereby certify that this plan, specification, or report was prepared by me or under my direct supervision and that I am a duly Licensed Professional Engineer under the laws of the State of Minnesota

Engineer
Date 12/08/22 Lic. No. 21112

DESIGNED BY: LLL	DATE: 12/08/22
DRAWN BY: LLL	FILE No. 19-07
CHECKED BY: LLL	



CITY OF RAMSEY
7550 SUNWOOD DRIVE
RAMSEY, MN 55303
(763) 427-1410 FAX (763) 433-9898

EXISTING OUTLET CONDITION

WETLAND 114P OUTLET MODIFICATIONS
CITY PROJECT NO. 19-07
CITY OF RAMSEY, MINNESOTA

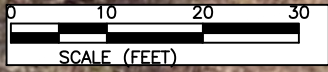

- NOTES:
1. PROTECT EXISTING TREE DURING INSTALLATION OF OCS.
 2. INSTALL OUTLET CONTROL STRUCTURE (OCS)
 3. RESTORE DISTURBED AREAS WITH HYDROSEED

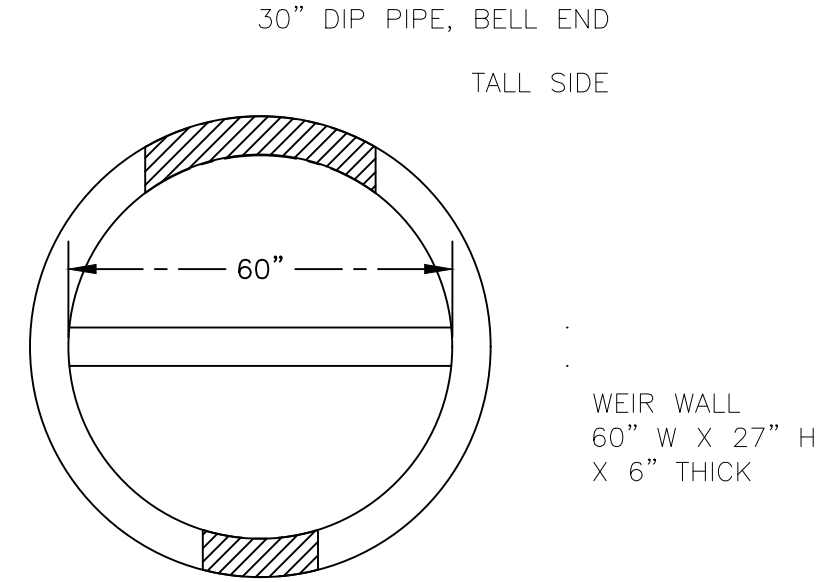

18" DOG - NO PIPE
PLAN VIEW

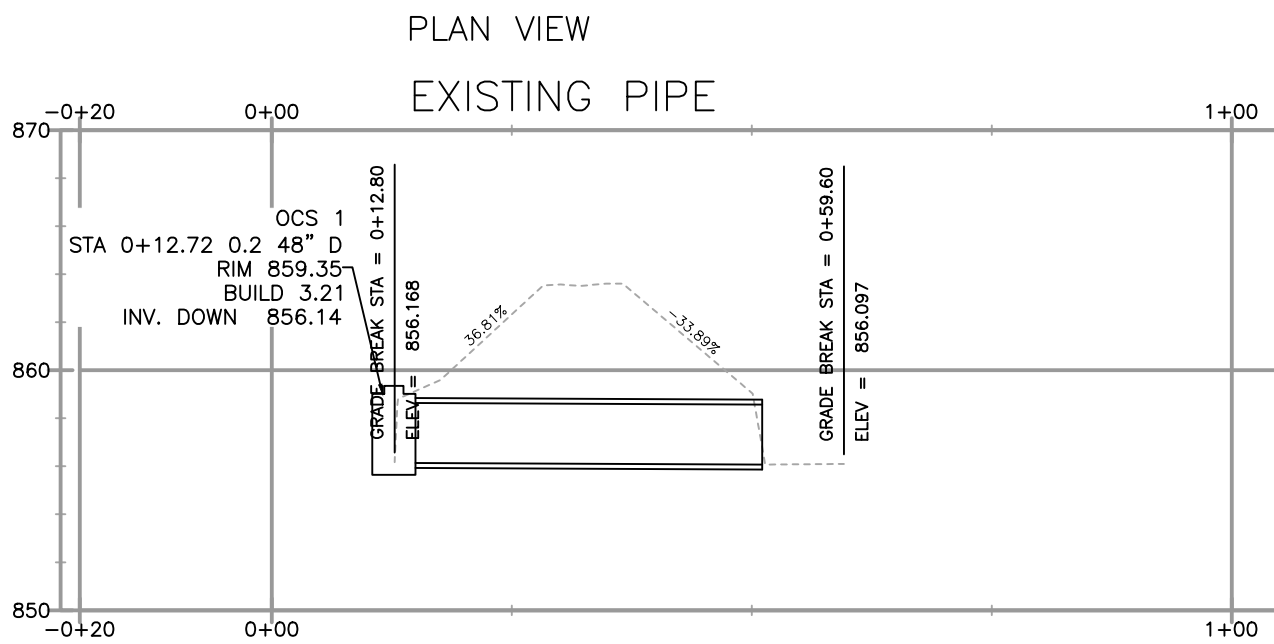

PROFILE VIEW

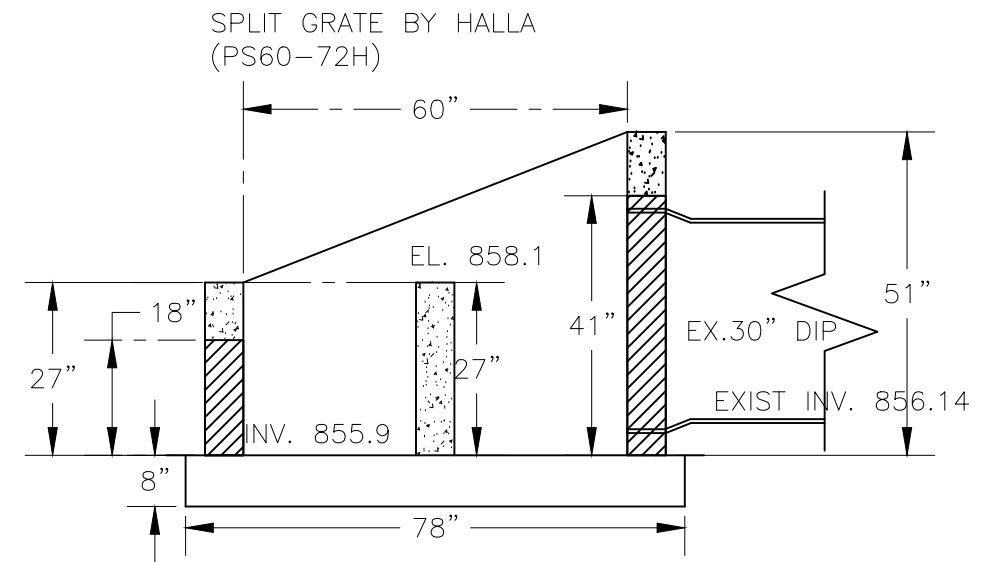

PROFILE VIEW
OCS DETAIL

DATE	REVISION

I hereby certify that this plan, specification, or report was prepared by me or under my direct supervision and that I am a duly Licensed Professional Engineer under the laws of the State of Minnesota

Engineer
Date 12/08/22 Lic. No. 21112

DESIGNED BY: LLL	DATE: 12/08/22
DRAWN BY: LLL	FILE No. 19-07
CHECKED BY: LLL	

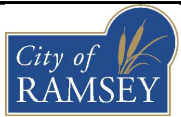



CITY OF RAMSEY
7550 SUNWOOD DRIVE
RAMSEY, MN 55303
(763) 427-1410 FAX (763) 433-9898

PROFILE & DETAILS

WETLAND 114P OUTLET MODIFICATIONS
CITY PROJECT NO. 19-07
CITY OF RAMSEY, MINNESOTA



LEGEND

-  LOT LINE
-  REMOVE AND REPLACE BOARDWALK
-  EXISTING SANITARY MANHOLE

NOTE:

1. RAISE CASTING BY REMOVING EXISTING CASTING AND RINGS, INSTALLING NEW RINGS, REPLACING CASTING AND INSTALLING WATERTIGHT WRAP ON NEW RINGS AND CASTING, BONDING WRAP TO EXISTING STRUCTURE.
2. CONTRACTOR IS RESPONSIBLE FOR FIXING ANY DAMAGE TO EXISTING LANDSCAPING.

DATE	REVISION

I hereby certify that this plan, specification, or report was prepared by me or under my direct supervision and that I am a duly Licensed Professional Engineer under the laws of the State of Minnesota

Engineer
Date 12/08/22 Lic. No. 21112

DESIGNED BY: LLL	DATE: 12/08/22
DRAWN BY: LLL	FILE No.:
CHECKED BY: LLL	19-07

 CITY OF RAMSEY
7550 SUNWOOD DRIVE
RAMSEY, MN 55303
(763) 427-1410 FAX (763) 433-9898

SANITARY MANHOLE ADJUSTMENTS

WETLAND 114P OUTLET MODIFICATIONS
CITY PROJECT NO. 19-07
CITY OF RAMSEY, MINNESOTA

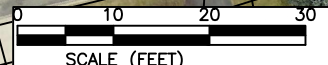

- NOTE:**
1. RAISE CASTING BY REMOVING EXISTING CASTING AND RINGS, INSTALLING NEW RINGS, REPLACING CASTING AND INSTALLING WATERTIGHT WRAP ON NEW RINGS AND CASTING, BONDING WRAP TO EXISTING STRUCTURE.
 2. CONTRACTOR IS RESPONSIBLE FOR FIXING ANY DAMAGE TO EXISTING LANDSCAPING.

DATE	REVISION

I hereby certify that this plan, specification, or report was prepared by me or under my direct supervision and that I am a duly Licensed Professional Engineer under the laws of the State of Minnesota

 Engineer
 Date 12/08/22 Lic. No. 21112

DESIGNED BY: LLL	DATE: 12/08/22
DRAWN BY: LLL	FILE No.:
CHECKED BY: LLL	19-07

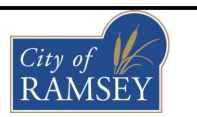

CITY OF RAMSEY
 7550 SUNWOOD DRIVE
 RAMSEY, MN 55303
 (763) 427-1410 FAX (763) 433-9898

STORM SEWER & GRADING

WETLAND 114P OUTLET MODIFICATIONS
 CITY PROJECT NO. 19-07
 CITY OF RAMSEY, MINNESOTA