



October 23, 2023

Bruce Westby  
 City of Ramsey  
 7550 Sunwood Drive NW  
 Ramsey, MN 55303

**Re: Water Treatment Plant – Construction Contingency Expense No. 2**

Dear Mr. Westby:

AE2S continues to oversee the construction of the City of Ramsey’s new WTP. Magney has almost completed pouring the walls in the Reservoir and are getting prepared to pour the pipe gallery level in the Water Treatment Plant. Our engineering team has continued to coordinate with Magney and further refine the installation details of other pieces of equipment. Through those investigations we have identified some items that will require adjustments. This letter is intended to outline those adjustments and summarize the current project budget in order for the City to fully understand the status of the project.

**Basis for of Construction Contingency Expenses:**

Currently seven (7) requests for pricing (RFP) have been submitted to Magney. A full list of those requests are shown below. To date AE2S has received pricing back on six (6) of the RFP’s, and two (2) separate proposals. We would like to move forward and process Construction Contingency Expense No. 2, which will include price RFP 002, RFP 004, and the two (2) proposals for reimbursement. If the Contractor would like to include a request for extension as a result of these changes, a formal Change Order request will be issued at a different time.

Expense No.	RFP No.	Description	Total Cost	Required	Status
1	001	Mixing Pumps Pipe Upsizing	\$51,287.38	Y	Approved
2	002	Upsizing Air Exchange in Plate Settler Room	\$16,580.02	N	Pending
1	003	Admin Ceiling Grid Color	\$2,609.25	N	Approved
2	004	Blower Pipe Upsizing	\$55,230.60	Y	Pending
-	005	<del>Flowable Fill</del>	-	N	<del>Rejected</del>
1	006	Storm and Plumbing Updates	\$22,550.28	Y	Approved
2		Building Permit Reimbursement	\$62,887.28	Y	Approved
2		Groundbreaking Signage Reimbursement	\$956.12	Y	Approved
	007	Backwash Supply Piping Modifications		Y	Expected

Note: Any extension delays will be approved as a separate Change Order and will not be included in this Construction Contingency Expense.



**RFP No. 002: Air Exchange Modifications in Plate Settler Room:**

The initial plans for the project were to include an emissions hood over the top of each plate settler to vent out any potential radon emissions. As a result, the size of the air exchange system in the plate settler room was reduced. After talking with several utilities with similar plate settlers, it was determined that a vent hood would make it difficult for operators to access and maintain integral parts of the plate settler. It is our recommendation that we remove the radon emissions hood from the project and accurately size the air exchange system for the space. This will include costs associated with increasing ductwork and louver sizes for the room. The proposal also includes a cost deduction for the original bid price of the radon emissions hood and associated ductwork.

**RFP No. 004: Blower Pipe Upsizing:**

The air scour blower supplier is recommending that the suction and discharge piping on the blower be upsized from the proposed 8” to 10” to velocity and noise from the system. This change will not alter the price of the blower system package that will be supplied by the manufacturer. However, it will require Magney to upsize the blower suction and distribution pipes and valves from the blower to the air scour system at the filters. In addition to pipes and valves being upsized, we requested Magney to include pricing for the suction and bypass pipes from the blower to penetrate the roof rather than the west exterior wall. This will reduce exterior noise from the blower and allow for better operator access for cleaning the bug screen and any other future maintenance.

**Building Permit Reimbursement:**

In accordance with the Supplementary Conditions 7.09 (specifically, SC-7.09 B, 3) Magney Construction is seeking reimbursement of the costs associated with the City of Ramsey Building Permit. This reimbursement was approved and applied to Pay Application No. 4 as a Construction Contingency Expense.

**Groundbreaking Sign Reimbursement:**

Magney Construction, Inc. is seeking compensation for necessary labor, material and/or equipment to provide the groundbreaking ceremony sign, as requested in our email correspondences on 7/13/23. Magney Construction expedited the fabrication and delivery of the AE2S' designed signage for the City of Ramsey's Groundbreaking Ceremony. This reimbursement was approved and applied to Pay Application No. 4 as a Construction Contingency Expense.

**Summary of General Construction Contingency Costs:**

AE2S has summarized all known construction contingency expenses at this time in order to help the City of Ramsey better understand the current contingency status. As Construction progresses, AE2S will continue to provide cost updates and coordinate with City staff.

	<b>General Construction Contingency Amount</b>
Original	\$ 950,000.00
Expense No. 1	\$76,446.53
Expense No. 2	\$135,654.02
<b>Net Expenses to Date:</b>	<b>\$212,100.55</b>
<b>Available Construction Contingency =</b>	<b>\$737,899.45</b>



<b>SEND TO</b>			
<i>Company name</i> AE2S		<i>From</i> Kevin Vranicar	
<i>Attention</i> Mr. Ryan Hanson		<i>Date</i> 9/27/2023	
<i>E-mail</i> <a href="mailto:Ryan.Hanson@ae2s.com">Ryan.Hanson@ae2s.com</a>	<i>Phone</i> (612) 220-0154	<i>Magney Proposal # 007</i> RFP No.002 Air Exchange Modifications @ Plate Settler Rm	

Urgent       Please comment       Please review       For your information

Total pages, including cover: 4

**COMMENTS**

**Re: Ramsey Water Treatment Plant - Ramsey, MN**

Ryan,  
 Magney Construction, Inc. is pleased to present the following quotation to furnish the necessary labor, material, and equipment to complete the Air Exchange Modifications, as described in your Request for Proposal No. 002, dated 5/25/23. Please see the attached proposals from our vendor and subcontractor for additional information and/or specific scopes of work. The costs associated with this change are summarized below.

<b>Labor:</b>	\$	-
<b>Material:</b> Treatment Resources, Inc. (see attached) - CREDIT	\$	(2,800.00)
<b>Equipment:</b>	\$	-
<b>Subcontractor:</b> Major Mechanical (see attached)	\$	18,631.00
<b>Subtotal</b>	\$	15,831.00
<b>General Contractor's Overhead</b>	\$	511.55
<b>Bond &amp; Insurance premiums</b>	\$	237.47
<b>Lump Sum Total:</b>	\$	<b>16,580.02</b>

<b>Additional Calendar Days Required for this Change (Including material lead time):</b>	<b>TBD</b>
--	------------

Please review this proposal and feel free to contact me with any questions, comments or concerns.

Thank you,

  
 Kevin Vranicar  
 Vice President

<i>Accepted By</i>	<i>Date</i>



TREATMENT RESOURCES  
 11670 FOUNTAINS DRIVE SUITE 200  
 MAPLE GROVE, MN 55369  
 612-201-5630

# Quotation

**This Proposal is  
 Valid for 30 Days  
 from the date of  
 Issue**

Date	Estimate
8/22/23	

Name / Address
Magney Construction 1401 Park Rd, Chanhassen, MN 55317  Attn: Noah Pundsack

Ship To
Ramsey Water Treatment Plant

Terms	Rep	Project
NET 30		Ramsey, MN WTP

Item	Description	Qty	U/M	Unit Price	Total
Radon Hood	Deduct request for removing radon duct/hood for HEI plate settler in section			2,800.00	2,800.00

<b>Subtotal</b>	\$2,800.00
<b>Sales Tax (6.875%)</b>	\$
<b>Total</b>	\$2,800.00



7601 Northland Drive North • Brooklyn Park, MN 55428 • Ph: (763) 424-6680 • [www.majormechn.com](http://www.majormechn.com)

September 19, 2023

Magney Construction  
1401 Park Road  
Chanhassen, MN 55317  
Attn: Noah Pundsack

**RE: Ramsey Water Treatment Plant  
Ramsey, Minnesota  
PR-002 – Air Exchange Modifications**

Noah,

Added cost to increase equipment and ductwork sizes per PR-002.

Major Mechanical	
Increase Equipment Size (MAU, AC Coil, CU, Inline Fan)	\$ 3,800.00
Increase Louver, Damper and Added Registers	\$ 2,200.00
Added Material for Increased Duct Sizes	<u>\$ 3,632.00</u>
Material Added Material	\$ 9,632.00
Taxes	<u>\$ 724.81</u>
Sub-Total	\$ 10,356.81
Labor 42 hours x \$105.00=	<u>\$ 4,410.00</u>
Sub-Total	\$ 14,766.81
Mark-Up (15%)	<u>\$ 2,216.52</u>
<b>Major Mechanical Total</b>	<b>\$ 16,993.33</b>

Sub-Contractors	
Insulation	\$ 1,360.00
Test & Balance	<u>\$ 200.00</u>
Sub-Total	\$ 1,560.00
Mark-Up (5%)	<u>\$ 78.00</u>
Sub-Contractor Total	\$ 1,638.00
Major Mechanical Total	<u>\$ 16,993.33</u>
<b>Total Add PR-002</b>	<b>\$ 18,631.00</b>

**PR-002 Notes:**

- No Drawing Provided. Pricing based on ductwork sized to match original drawings. If sizes are different than what Engineer will require, pricing may change.

If you have any questions or would like to discuss the scope or pricing, please feel free to contact me at 763-296-5649 office or 763-331-4735 mobile.

Thank You,

Jay Johnson  
Project Manager  
Major Mechanical

<b>SEND TO</b>			
<i>Company name</i> AE2S		<i>From</i> Kevin Vranicar	
<i>Attention</i> Mr. Ryan Hanson		<i>Date</i> 10/2/2023	
<i>E-mail</i> <a href="mailto:Ryan.Hanson@ae2s.com">Ryan.Hanson@ae2s.com</a>	<i>Phone</i> (612) 220-0154	<i>Magney Proposal # 004</i> Request For Proposal No. 004 Blower Piping Modifications	

Urgent     
  Please comment     
  Please review     
  For your information

Total pages, including cover: 6

## COMMENTS

### Re: Ramsey Water Treatment Plant - Ramsey, MN

Ryan,

Magney Construction, Inc. is pleased to present the following quotation to provide the necessary labor, material and equipment to modify and upsize the specified 8-inch blower system piping, fittings, valves, nuts, bolts and gaskets to 10-inch piping, fittings, valves, nuts, bolts and gaskets, per your Request For Proposal No. 004. We have also included the costs to relocate the blower inlet/discharge piping locations from the sidewall to the roof, as shown. The costs associated with this change are summarized below.

<b>Labor:</b> Additional Labor Required for 10" Pipe vs. 8" Pipe	\$	5,878.49
<b>Material:</b> Additional Costs for 10" vs. 8" Pipe, Fittings, N,B&G, (incl. tax)	\$	34,145.74
<b>Material:</b> Vessco, Inc. - 10" vs. 8" Valves (incl. tax) (see attached)	\$	2,789.63
<b>Material:</b> Major Mechanical - Roof Curb & Curb Cover (see attached)	\$	1,192.46
<b>Equipment:</b> Misc. Small Tools and Equipment (10% of Labor)	\$	587.85
<b>Subcontractor:</b> RTL Construction, Inc. - Install Roof Curb (see attached)	\$	288.31
<b>Subcontractor:</b> Central Roofing Company - Roofing Work (see attached)	\$	750.00
<b>Subcontractor:</b> Fresh Blast Painting - Additional Painting (see attached)	\$	2,040.00
<b>Subtotal</b>	\$	47,672.47
<b>General Contractor's Overhead</b>	\$	6,843.04
<b>Bond &amp; Insurance premiums</b>	\$	715.09
<b>Lump Sum Total:</b>	\$	<b>55,230.60</b>

<b>Additional Working Days Required for this Change</b> (Including material lead time):	<b>TBD</b>
---	------------

Please review this proposal and feel free to contact me with any questions, comments or concerns.

Thank you,

  
 Kevin Vranicar  
 Vice President

<i>Accepted By</i>	<i>Date</i>

## Kevin Vranicar

---

**From:** Cory Stough <CStough@vessco.com>  
**Sent:** Thursday, July 20, 2023 3:24 PM  
**To:** Noah Pundsack; Megan Harwick  
**Subject:** RE: Ramsey Mn WTP Valve pricing

Noah,

\$430 a valve increase. \$2580 total.

Plus Tax

**Thank you,**

**Cory Stough** | Inside Sales - Central Region  
C: (612) 417-7530 | W (763) 297-2027 | [cstough@vessco.com](mailto:cstough@vessco.com)

8217 Upland Circle, Chanhassen, MN 55317  
Vessco Holdings | [Celebrating Over 40 Years of Clean Water](#)



---

**From:** Noah Pundsack <npundsack@magneyconstruction.com>  
**Sent:** Thursday, July 20, 2023 10:03 AM  
**To:** Cory Stough <CStough@vessco.com>; Megan Harwick <MHarwick@vessco.com>  
**Subject:** Ramsey Mn WTP Valve pricing

Cory / Megan,

Regarding the Ramsey Mn WTP Project.

Can you give us a price quote for the following valves as 10"? And the price increase from the 8" versions?

FLT1-ABW-BFV1  
FLT2-ABW-BFV1  
FLT3-ABW-BFV1  
FLT4-ABW-BFV1  
FLT5-ABW-BFV1  
FLT6-ABW-BFV1

Thank you,

**Noah Pundsack**  
**Project Engineer**  
**Mobile: (320) 429-1186**  
[NPundsack@magneyconstruction.com](mailto:NPundsack@magneyconstruction.com)



7601 Northland Drive North • Brooklyn Park, MN 55428 • Ph: (763) 424-6680 • [www.majormech.com](http://www.majormech.com)

September 19, 2023

Magney Construction  
1401 Park Road  
Chanhassen, MN 55317  
Attn: Noah Pundsack

**RE: Ramsey Water Treatment Plant  
Ramsey, Minnesota  
PR-004 – Curb and Cover**

Noah,

Added cost to provide curb and curb cover for piping.

Major Mechanical	
Material	\$ 959.00
Taxes	\$ <del>72.16</del> 77.92
Sub-Total	\$ <del>1,031.16</del> 1,036.92
Mark-Up (15%)	\$ <del>154.67</del> 155.54
<b>Major Mechanical Total</b>	<b>\$ <del>1,186.00</del> 1,192.46</b>

If you have any questions or would like to discuss the scope or pricing, please feel free to contact me at 763-296-5649 office or 763-331-4735 mobile.

Thank You,

Jay Johnson  
Project Manager  
Major Mechanical

Ramsey WTP Request for Change  
 6900 143rd Ave NW  
 Ramsey, MN 55303



To: **Magney Construction**

RFC Number: RFP #004

This Request: **\$288.31**

RTL Job # 23-217

Date: 9/1/2023

<b>COST SUMMARY</b>		
<b>Description of Change:</b> Added roof blocking for a roof curb (provided by others).		
	Cost	Notes/Attachments
<b>Labor</b>	\$ 200.00	
<b>Material</b>	\$ 62.10	
<b>Total Cost</b>	\$ 262.10	
<b>Overhead and Profit</b>	\$ 26.21	10%
<b>Self-Performed Total</b>	<b>\$288.31</b>	
<b>Subcontractors</b>	\$ 0.00	
<b>Overhead and Profit on Subs</b>	\$ 0.00	
<b>Subcontractor Total</b>	<b>\$0.00</b>	
<b>Total Change in Contract</b>	<b>\$288.31</b>	

<b>Detail Breakdown Below:</b>			
	Hours	Rate	Total
Labor	2	\$100.00	\$200.00
Labor Total	2		\$200.00
Material			Total
Material Total			\$62.10

The above work is subject to the same conditions as specified in the original contract unless otherwise stipulated. Upon approval the sum of \$288.31 will be added to the contract price.

Authorized Signature: \_\_\_\_\_ Date: \_\_\_\_\_

Magney Construction



4550 Main Street NE, Minneapolis, MN 55421 \* (763)572-0660, Fax (763)572-0230

## Change Order Request

Magney Construction  
1401 Park Road  
Chanhassen, MN  
Attn: Noah Pundsack

RE: Ramsey Water Treatment Plant

This change order request is in regards to the following item:

Added roof curb for pipe penetrations for blower piping modifications.

Change Order Total: **\$750.00**

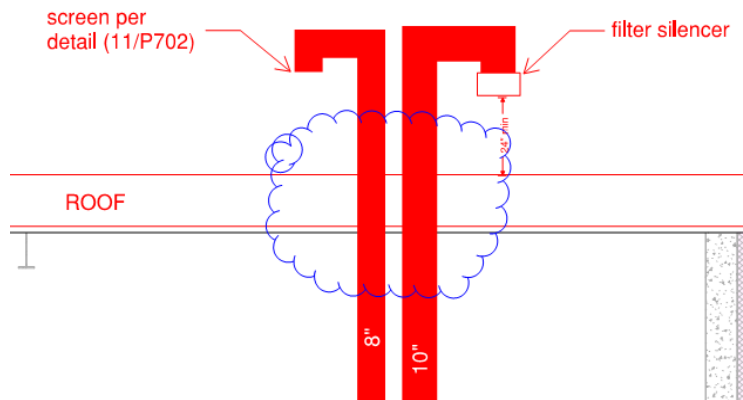

Should you require any additional information please feel free to contact us at your earliest convenience.

Thanks,

Jeremy Stuhr



**Office: 651-447-2218**

*Date 08/11/2023*

We are pleased to submit a proposal for the following project:

**Ramsey MN WTP**

For the following sections:

***RFP 004 - Paint***

Our Proposal is for:

***Two Thousand, Forty Dollars.***

***\$2,040.00***

RFP dated: 5/26/2023  
Addenda: N/A

Unit Prices: None  
Allowances: None  
Alternates: None

**OUR BASE BID INCLUDES:**

1. Prep and coatings per specification on larger blower piping and valves.
2. Labor, Materials, Equipment, Sales Tax, & Mobilization.

**OUR BASE BID DOES NOT INCLUDE:**

1. Any bonds required by Owner or GC.
2. Prevailing wage or Davis-Bacon wage rates.
3. Pipe labeling.
4. Temp heat—indirect, externally-vented temp heat to be provided by GC or Owner if needed.

**OTHER BID NOTES:**

1. All paint systems included in this bid will be Sherwin-Williams products. Where factory/shop priming is required by spec, please ensure manufacturers are using the appropriately compatible Sherwin-Williams primer.

<b>SEND TO</b>			
Company name AE2S		From Kevin Vranicar	
Attention Mr. Ryan Hanson		Date 8/22/2023	
E-mail <a href="mailto:Ryan.Hanson@ae2s.com">Ryan.Hanson@ae2s.com</a>	Phone (612) 220-0154	Proposal # 003 - Building Permit Reimbursement	

Urgent     
  Please comment     
  Please review     
  For your information

Total pages, including cover: 6

## COMMENTS

### Re: Ramsey Water Treatment Plant - Ramsey, MN

Ryan,

In accordance with the Supplementary Conditions 7.09 (specifically, SC-7.09 B, 3) Magney Construction is seeking reimbursement of the costs associated with the City of Ramsey Building Permit. If the cost of this reimbursement will be run through the project (i.e. change order) please use the lump sum total below. If a direct payment will be made from the City of Ramsey to Magney Construction, please deduct the associated bonding and insurance premiums noted below.

<b>Labor:</b>	\$	-
<b>Material:</b> Building Permit Fee Reimbursement (see attached)	\$	61,957.91
<b>Equipment:</b>	\$	-
<b>Subcontractor:</b>	\$	-
<b>Subtotal</b>	\$	61,957.91
<b>General Contractor's Overhead</b>		N/A
<b>Bond &amp; Insurance premiums</b>	\$	929.37
<b>Lump Sum Total:</b>	\$	<b>62,887.28</b>

<b>Additional Working Days Required for this Change (Including material lead time):</b>	<b>TBD</b>
---	------------

Please review this proposal and feel free to contact me with any questions, comments or concerns.

Thank you,



Kevin Vranicar  
Vice President

Accepted By	Date

# City of Ramsey

License Number: 2023232  
Expiration: 12/31/2023

Magney Construction, Inc.  
1401 Park Road  
Chanhassen MN 55317

Pursuant to City Ordinances and regulations and conditioned upon payment of the required fee, License is hereby granted for the term and purpose stated.

License Type:  
General Building Contractor

  
Building Official

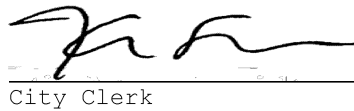
  
City Clerk

POST AT LOCATION LICENSED  
NOT TRANSFERABLE  
NOT VALID UNLESS COUNTERSIGNED

CUT HERE

## City of Ramsey

<u>License Type</u>	<u>Fee</u>	<u>Expiration</u>	<u>License Nbr</u>
General Building Contractor	\$50.00	12/31/2023	2023232

### Chapter 26 Article VI. Construction Contractors

**Sec. 26-201. Expiration.** All licenses issued under the Code of the City shall expire on December 31st following the date of issuance. If a license is granted hereunder and is not renewed prior to expiration then all rights granted by such license shall cease and any work performed after the expiration of the license shall be in violation of the Code of the City. All licenses are subject to revocation or forfeiture prior to expiration date.

Mail To:

Magney Construction, Inc.  
1401 Park Road  
Chanhassen MN 55317

**CITY OF RAMSEY**

7550 SUNWOOD DR NW  
ANOKA, MN 55303  
7634271410

City of Ramsey  
reference #10592

Cashier: Chao X.  
19-Apr-2023 1:07:08P

Transaction <b>201906</b>	
1 Contractor License	\$50.00
<b>Total</b>	<b>\$50.00</b>
CREDIT CARD SALE	\$50.00
VISA 9258	

Retain this copy for statement  
validation

Station: Building Dept  
19-Apr-2023 1:21:41P  
\$50.00 | Method: KEYED  
VISA XXXXXXXXXXXX9258  
MANUALLY ENTERED  
Reference ID: 310900530283  
Auth ID: 042529  
MID: \*\*\*\*\*7996  
AthNtwkNm: VISA

Thank you and have a great day!

Clover ID: MZ50EVSK0DZMA  
Payment 75W7NXVHGS1W8

Clover Privacy Policy  
<https://clover.com/privacy>

## Kevin Vranicar

---

**From:** epermits@logis.org  
**Sent:** Friday, April 21, 2023 4:23 PM  
**To:** Kevin Vranicar  
**Subject:** ePermits Order Confirmation

Hello Kevin Vranicar

Thank you for using the Ramsey ePermits website!

Here is the information for the permit(s) you purchased.

Permit Number: RA054130  
Commercial Building New  
6900 143rd Ave Nw

This permit requires a plan review and needs to be approved before it is issued.

This plan review permit may require additional actions on the part of the applicant before it can be approved. Please contact the city for additional instructions.

Comments:

A series of inspections are required for new commercial construction.

Please call 763-433-9850 to schedule inspections -OR- schedule online at <http://www.cityoframsey.com/permits>

Please Note: The Application Fee is non-refundable.

Thank you!!

**Order Total: \$20.00**

Please remember, it is the permit holder's responsibility to call and schedule inspections. Please call City of Ramsey at (763) 433-9850 to setup the inspection times and dates or if you have any questions regarding this permit.

DO NOT REPLY TO THIS EMAIL

# PERMIT

## City of Ramsey

7550 Sunwood Drive NW  
Ramsey, MN 55303  
763-433-9850  
www.ci.ramsey.mn.us

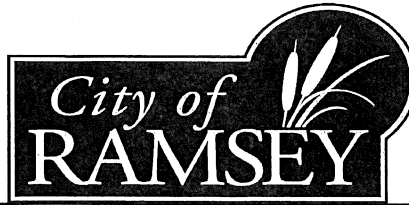

Permit Type: Building  
Permit Number: RA054130  
Date Issued: 07/25/2023  
Permit Category: ePermit

### Site Address: 6900 143rd Ave NW

Lot:                      Block:                      Addition: Unplatted  
PID: 99-99-99-99-6900  
Use:                      City of Ramsey Water Treatment Plant

### Description:

Sub Type:                      Institutional                      Construction Type:                      Type II B  
Work Type:                      New  
Description:                      New Building  
Census Code:                      -                      Occupancy:                      B  
Zoning:                                           F-2  
Square Feet:                      0                      H-3

**Comments:**                      New Commercial Construction: Water Treatment Plant.  
Please call 763-433-9850 to schedule inspections -OR- schedule online at <http://www.cityoframsey.com/permits>  
Please Note: The Application Fee is non-refundable. Check #129380  
Thank you!!

### Fee Summary:

	<u>Description</u>	<u>Amount</u>	<u>Revenue Code</u>
Valuation: 1,677,300.00	BL - Plan Review - Commercial	\$5,033.89	9101.4307
	Building Application Fee Credit	(\$20.00)	9101.4307
	Permit - Base Fee	\$7,744.45	9101.4205
	Surcharge - Based on Valuation	\$770.92	9101.2081
	SAC/Sewer Availability - Commercial/Instituti	\$24,850.00	9602.2083
	WAC - Water Availability Charge	\$14,810.00	9601.4606
	<b>Total:</b>	<b>\$53,189.26</b>	

### Contractor:

Magney Construction, Inc.  
1401 Park Road  
Chanhassen MN 55317  
(952) 474-1674

- Applicant -

Lic. #: 2023232

### Owner:

City of Ramsey  
7550 Sunwood Drive NW  
Ramsey MN 55303  
(763) 427-1410

THIS PERMIT BECOMES VOID IF WORK AUTHORIZED IS NOT COMMENCED WITHIN 180 DAYS OR IF WORK IS SUSPENDED OR ABANDONED FOR A PERIOD OF 180 DAYS AT ANY TIME AFTER WORK IS COMMENCED. PERMIT EXPIRES AFTER 1 YEAR FROM DATE OF ISSUANCE. CITY CODE CHAPTER 105 SEC. 105-24.

Applicant/Permitee: Signature

Issued By: Signature

# PERMIT

## City of Ramsey

7550 Sunwood Drive NW  
Ramsey, MN 55303  
763-433-9850  
www.ci.ramsey.mn.us



Permit Type: **Plumbing**  
Permit Number: **RA054713**  
Date Issued: **08/03/2023**  
Permit Category: **ePermit**

### Site Address: 6900 143rd Ave NW

Lot:                   Block:            Addition: Unplatted  
PID:99-99-99-99-6900  
Use:    Ramsey Water Treatment

### Description:

Sub Type:        Commercial  
Work Type:       New  
Description:     New Commercial Plumbing

Meter Size	Meter Type	Manufacturer	Serial Number	Remote Number	Line Size
------------	------------	--------------	---------------	---------------	-----------

**Comments:** Domestic water meter to be a 4" Mach10 and landscape irrigation will be a 1.5" mach10 irrigation meter. Price for both water meters \$5,085.40 This City project is a tax exempt project so no sales tax on the meters  
Please call 763-433-9850 to schedule inspections -OR- schedule online at <http://www.cityoframsey.com/permits>. Please Note: The Application Fee is non-refundable. Thank you!!

### Fee Summary:

Valuation: 346,500.00

Description	Amount	Revenue Code
Plbg Permit Commercial 1% of Value	\$3,465.00	9101.4206
Plumbing Application Fee Credit	(\$25.00)	9101.4206
Surcharge - Based on Valuation	\$173.25	9101.2081
PL - 4" Compound Water Meter	\$5,085.40	9601.4656
<b>Total:</b>	<b>\$8,698.65</b>	

### Contractor:

Northern Plumbing Tech, Inc.  
16376-230th NW Avenue  
Elk River MN 55330  
(612) 910-2784

- Applicant -

Lic. #: PC001745  
Lic. #: 2023264

### Owner:

City of Ramsey  
7550 Sunwood Drive  
Ramsey MN 55303  
(612) 910-2794

THIS PERMIT BECOMES VOID IF WORK AUTHORIZED IS NOT COMMENCED WITHIN 180 DAYS OR IF WORK IS SUSPENDED ABANDONED FOR A PERIOD OF 180 DAYS AT ANY TIME AFTER WORK IS COMMENCED. PERMIT EXPIRES AFTER 1 YEAR DATE OF ISSUANCE. CITY CODE CHAPTER 105 SEC. 105-24.

Applicant/Permitee: Signature

Issued By: Signature

<b>SEND TO</b>			
Company name AE2S		From Kevin Vranicar	
Attention Mr. Ryan Hanson		Date 10/2/2023	
E-mail <a href="mailto:Ryan.Hanson@ae2s.com">Ryan.Hanson@ae2s.com</a>	Phone (612) 220-0154	Magney Proposal # 008 Groundbreaking Ceremony Sign	

Urgent       Please comment       Please review       For your information

Total pages, including cover:        2  

**COMMENTS**

**Re: Ramsey Water Treatment Plant - Ramsey, MN**

Ryan,  
 Magney Construction, Inc. is seeking compensation for necessary labor, material and/or equipment to provide the groundbreaking ceremony sign, as requested in our email correspondences on 7/13/23. Magney Construction expedited the fabrication and delivery of the AE2S' designed signage for the City of Ramsey's Groundbreaking Ceremony. The costs associated with this change are summarized below.

<b>Labor:</b> Pickup & Deliver Sign to City of Ramsey Public Works	\$	269.52
<b>Material:</b> Dahlen Sign Co. (see attached)	\$	456.98
<b>Equipment:</b> 1/2 Ton Pickup Truck (97.5 Miles @ \$0.95/Mile)	\$	92.63
<b>Subcontractor:</b>	\$	-
<b>Subtotal</b>	\$	819.13
<b>General Contractor's Overhead</b>	\$	122.87
<b>Bond &amp; Insurance premiums</b>	\$	14.13
<b>Lump Sum Total:</b>	\$	<b>956.12</b>

<b>Additional Calendar Days Required for this Change (Including material lead time):</b>	<b>0.0</b>
--	------------

Please review this proposal and feel free to contact me with any questions, comments or concerns.

Thank you,

  
 Kevin Vranicar  
 Vice President

Accepted By	Date

FAMILY OWNED SINCE 1956



# INVOICE

Invoice Number: 24725  
 Invoice Date: Jul 19, 2023

Voice: 952-888-3413  
 Fax: 952-888-7178

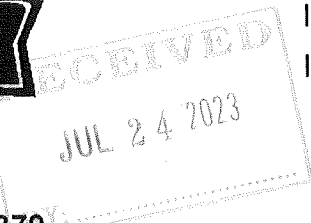

901 Stagecoach Road Shakopee, MN 55379

Bill To:
Magney Construction Inc. 1401 Park Road Chanhassen, MN 55317

Ship to:
Magney Construction Inc. 1401 Park Road Chanhassen, MN 55317

Customer ID	Customer PO	Payment Terms	
6619-2-E		Net 15 Days	
Sales Rep ID	Shipping Method	Ship Date	Due Date
	Airborne		8/3/23

Quantity	Description	Unit Price	Amount
1.00	4x8 ACM panel for Ramsey WTP Groundbreaking Ceremony	425.00	425.00

Subtotal	425.00
Sales Tax	31.98
Freight	
Total Invoice Amount	456.98
Payment/Credit Applied	
<b>TOTAL</b>	<b>456.98</b>

Check/Credit Memo No: