

W:\RMG\OUTDOOR - RMG\RMG23-105\_RHL - RAMSEY, MN - G-12311 - 12 30x48 CMDF20V LED 25.50x104 DRAWINGS\SI\24062020V - LED - 28 0A1 - G-12311 - IDIGITAL - RAMSEY, MN

**SIGN / SITE NOTES AND SPECIFICATIONS**  
(APPLY UNLESS OTHERWISE NOTED)

**CODE** - 2018 INTERNATIONAL BUILDING CODE

**WIND DESIGN** - SIGN STRUCTURE WIND LOADS ARE DETERMINED IN ACCORDANCE WITH ASCE 7-16 SECTION 29.3.1. BASIC WIND SPEED: 109 MPH (3 SECOND GUST) RISK CATEGORY: II EXPOSURE: C DESIGN WIND PRESSURE (ULTIMATE LEVEL): 38.4 PSF (AVERAGE), 56.5 PSF (MAXIMUM) REFER TO ASCE 7-16 FIGURE 29.3-1. ANY SIGN COMPONENTS NOT SPECIFICALLY DETAILED ON THESE DRAWINGS BUT ATTACHED TO THE STRUCTURE SHALL BE DESIGNED IN ACCORDANCE WITH THE INFORMATION ABOVE.

**DESIGN LIVE LOAD** - 2'-0" WIDE REAR MAINTENANCE PLATFORM. 40 PSF OR 300 LBS CONCENTRATED LOAD.

**DESIGN DEAD LOAD** - LED DISPLAY: 7500 LBS. EACH SIDE

**FOOTING** - EMBEDMENT DEPTH FOR FOOTING DOES NOT APPLY TO LOCATIONS WHERE WALLS OF THE HOLE WILL NOT STAND WITHOUT SUPPLEMENTAL SUPPORT, OR WHERE UNCOMPACTED FILL OR ORGANIC FILL EXISTS. FOUNDATION IS DESIGNED UTILIZING LATERAL BEARING PER IBC SECTION 1807.3.2.1. ALLOWABLE LATERAL SOIL PRESSURE PER IBC TABLE 1806.2 IS 150 PSF/FT (SOIL CLASS 4 - TYPE: SAND, SILTY SAND, CLAYEY SAND, SILTY GRAVEL AND CLAYEY GRAVEL). DESIGN LATERAL SOIL PRESSURE HAS BEEN MULTIPLIED BY 2 PER SECTION 1806.3.4. VERIFY SOIL TYPE DURING EXCAVATION. NOTIFY ENGINEER OF ANY DISCREPANCY.

EXTEND COLUMN PIPE TO BOTTOM OF FOOTING (3" CONCRETE COVER REQUIRED)

**GENERAL NOTES AND SPECIFICATIONS**  
(APPLY UNLESS OTHERWISE NOTED)

**STEEL** - WIDE FLANGES - ASTM A-992, OTHER SHAPES & PLATES - ASTM A-36.

**PIPE SECTIONS** - ASTM A-53 GR B OR A 252 GR 2, OR API - LX WITH MINIMUM YIELD STRENGTH AS INDICATED ON DRAWINGS.

**EXPANDED METAL GRATING** - EXPANDED METAL GRATING SHALL BE MANUFACTURED FROM CARBON STEEL IN CONFORMANCE WITH THE EXPANDED METAL MANUFACTURERS ASSOCIATION (EMMA) STANDARD NO. 557-99. STANDARDS FOR EXPANDED METAL. EMMA IS A DIVISION OF THE NATIONAL ASSOCIATION OF ARCHITECTURAL METAL MANUFACTURERS (NAAMM).

ALL STRUCTURAL STEEL SHALL BE FABRICATED AND ERECTED ACCORDING TO LATEST AISC SPECIFICATIONS AND STANDARD PRACTICE.

**REINFORCING STEEL** - FOR CUBE FOOTING, REINFORCING STEEL SHALL BE WELDED WIRE FABRIC 4x4 - W4 x W4 PER ASTM A185 OR A497M. WELDED WIRE FABRIC CAN BE SUBSTITUTED WITH POLYPROPYLENE FIBER MESH INCORPORATED INTO THE CONCRETE MIX AT THE RATE OF 3 LBS. PER CUBIC YARD. REINFORCING SHALL BE FABRICATED AND SECURED IN ACCORDANCE WITH ACI 318 AND CRSI MANUAL OF STANDARD PRACTICE. DO NOT WELD REINFORCING STEEL UNLESS APPROVAL IS OBTAINED FROM THE ENGINEER PRIOR TO CONSTRUCTION.

**PAINTING** - ALL STRUCTURAL STEEL, EXPOSED TO WEATHER, SHALL BE SHOP PRIMED AND PAINTED IN ACCORDANCE WITH AISC 335 (SPECIFICATION) AND AISC 303 (STANDARD PRACTICE).

**CONCRETE** - CONCRETE SHALL HAVE A MINIMUM COMPRESSIVE STRENGTH OF 2,500 PSI AT 28 DAYS AND BE PLACED IN ACCORDANCE WITH ACI 318. CONCRETE MIX SHALL BE PROPORTIONED WITH A MAXIMUM WATER CEMENT RATIO OF 0.50.

**WELDING** - ALL WELDING MATERIALS AND COMPONENTS SHALL BE IN COMPLIANCE WITH AWS D1.1 USING E70XX ELECTRODES.

**BOLTS** - ALL REGULAR SHALL CONFORM TO ASTM A-307. HIGH STRENGTH BOLTS SHALL CONFORM TO ASTM A-325N. ALL BOLTS SHALL BE INSTALLED TO A SNUG TIGHT CONDITION UNLESS NOTED TO BE PRE-TENSIONED (PT). PT BOLTS SHALL BE FULLY TENSIONED PER AISC TURN OF THE NUT METHOD (1/3 OF A TURN PAST A SNUG TIGHT CONDITION) OR OTHER AISC APPROVED TENSIONING METHOD.

**SPECIAL INSPECTIONS** - SPECIAL INSPECTIONS ARE REQUIRED PER CHAPTER 17 FOR THE FOLLOWING ITEMS:  
 --- STEEL CONSTRUCTION: MATERIAL VERIFICATION OF STRUCTURAL STEEL PERIODIC INSPECTION OF JOINT DETAILS  
 --- HIGH STRENGTH BOLTS: PERIODIC INSPECTION TO REVIEW FASTENER COMPONENTS AND TENSIONING.  
 --- FOUNDATION: PERIODIC INSPECTION TO VERIFY EXCAVATION DIMENSIONS

**STEEL FABRICATOR** - ALL STRUCTURAL STEEL SHALL BE SHOP FABRICATED BY THE FOLLOWING FABRICATOR:  
 PAGE STEEL  
 2040 INDUSTRIAL DRIVE  
 PAGE, AZ 85040

UNLESS SPECIFICALLY INDICATED AS FIELD WORK, NO FIELD WELDING IS ALLOWED WITHOUT THE APPROVAL OF THE ENGINEER OF RECORD. SPECIAL INSPECTIONS IS REQUIRED FOR ALL FIELD WELDING.

THE ERECTOR SHALL VERIFY ALL DIMENSIONS AND CONDITIONS IN THE FIELD BEFORE ERECTION AND NOTIFY ENGINEER OF ANY DISCREPANCIES. ERECTORS SHALL NOTIFY ENGINEER IF STRUCTURE IS LOCATED NEAR ANY BUILDINGS.

THE UNDERSIGNED ENGINEER WILL NOT SUPERVISE THE FABRICATION OR ERECTION OF THIS STRUCTURE.

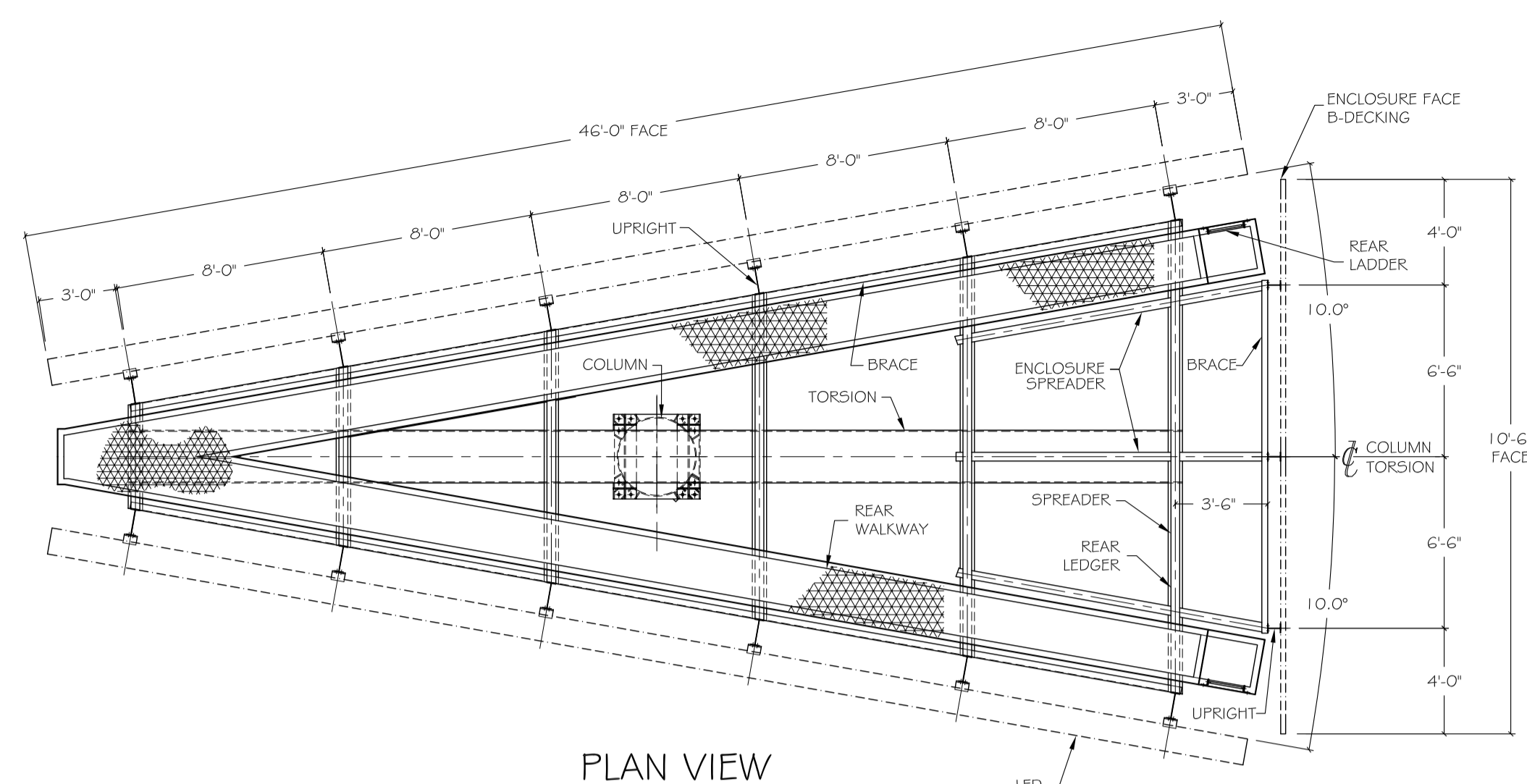

PLAN VIEW

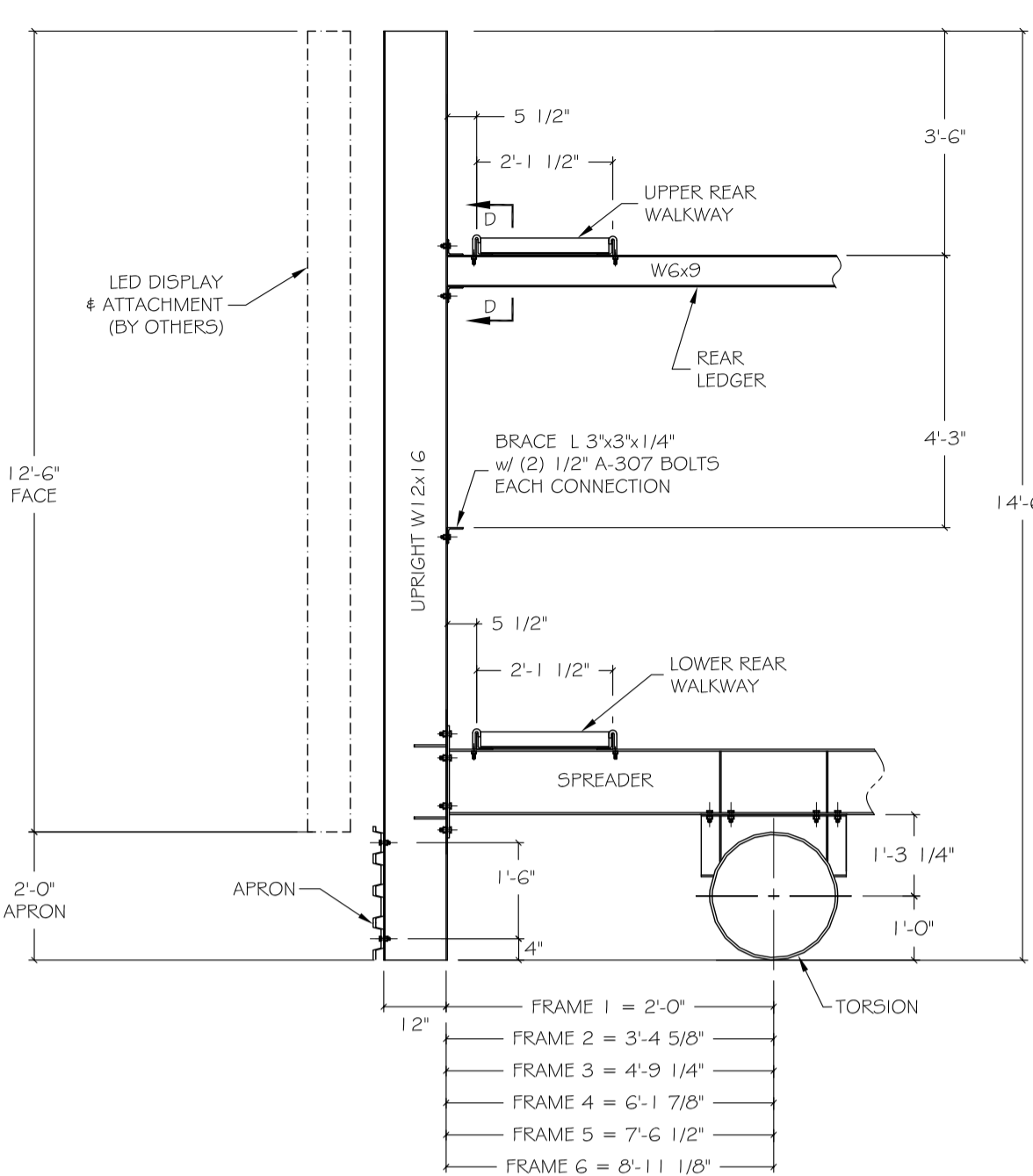

TYPICAL SECTION THRU SIGN

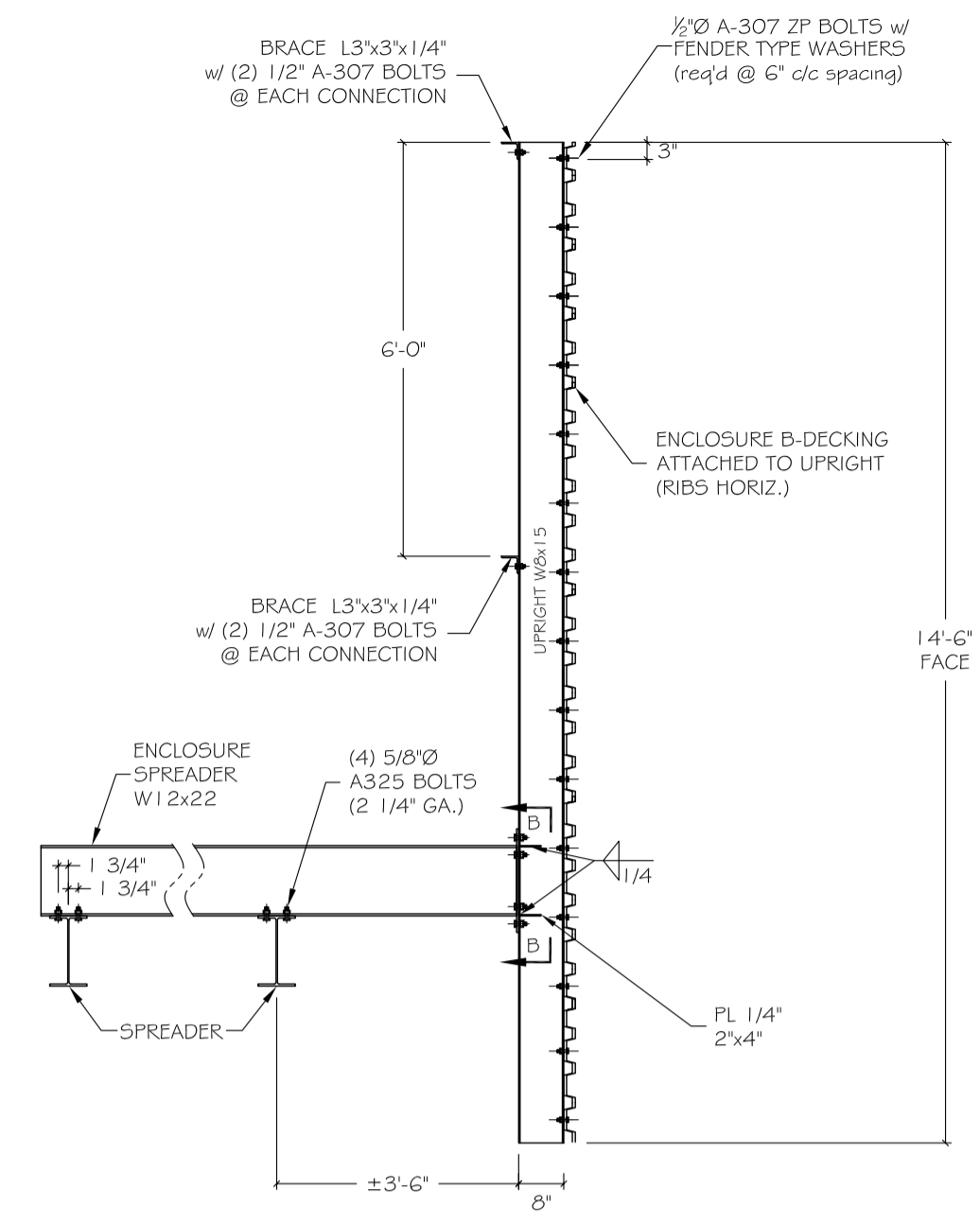

TYPICAL SECTION THRU ENCLASURE

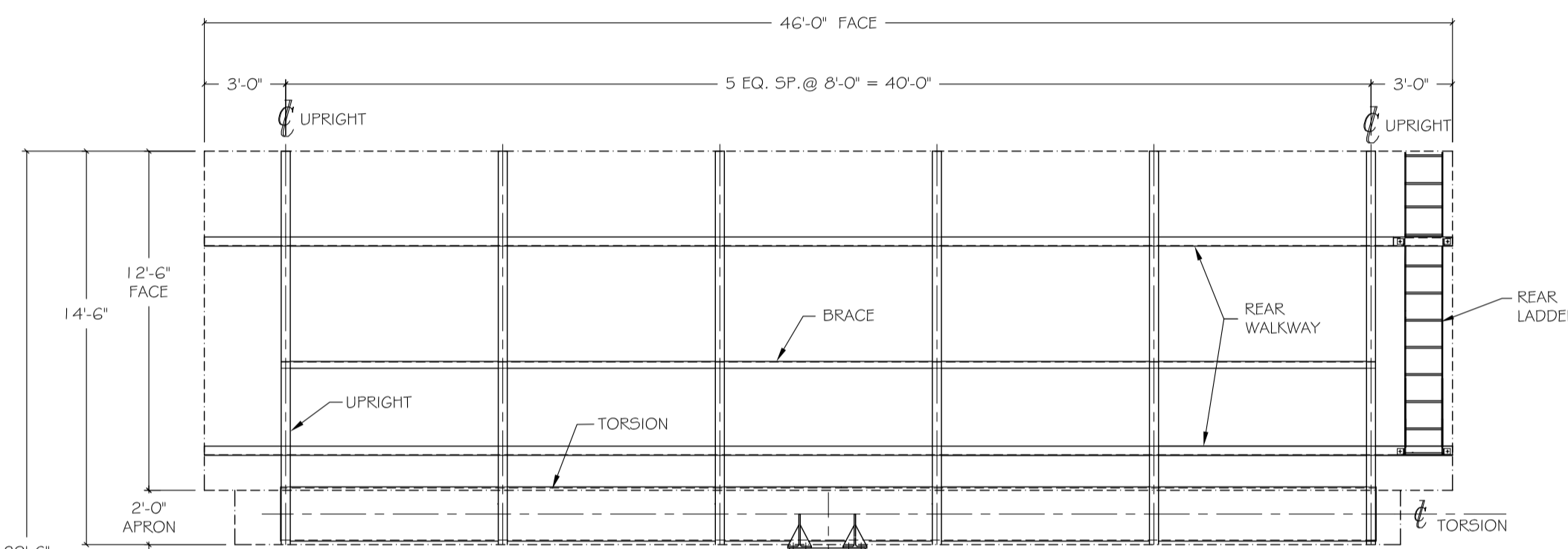

ELEVATION

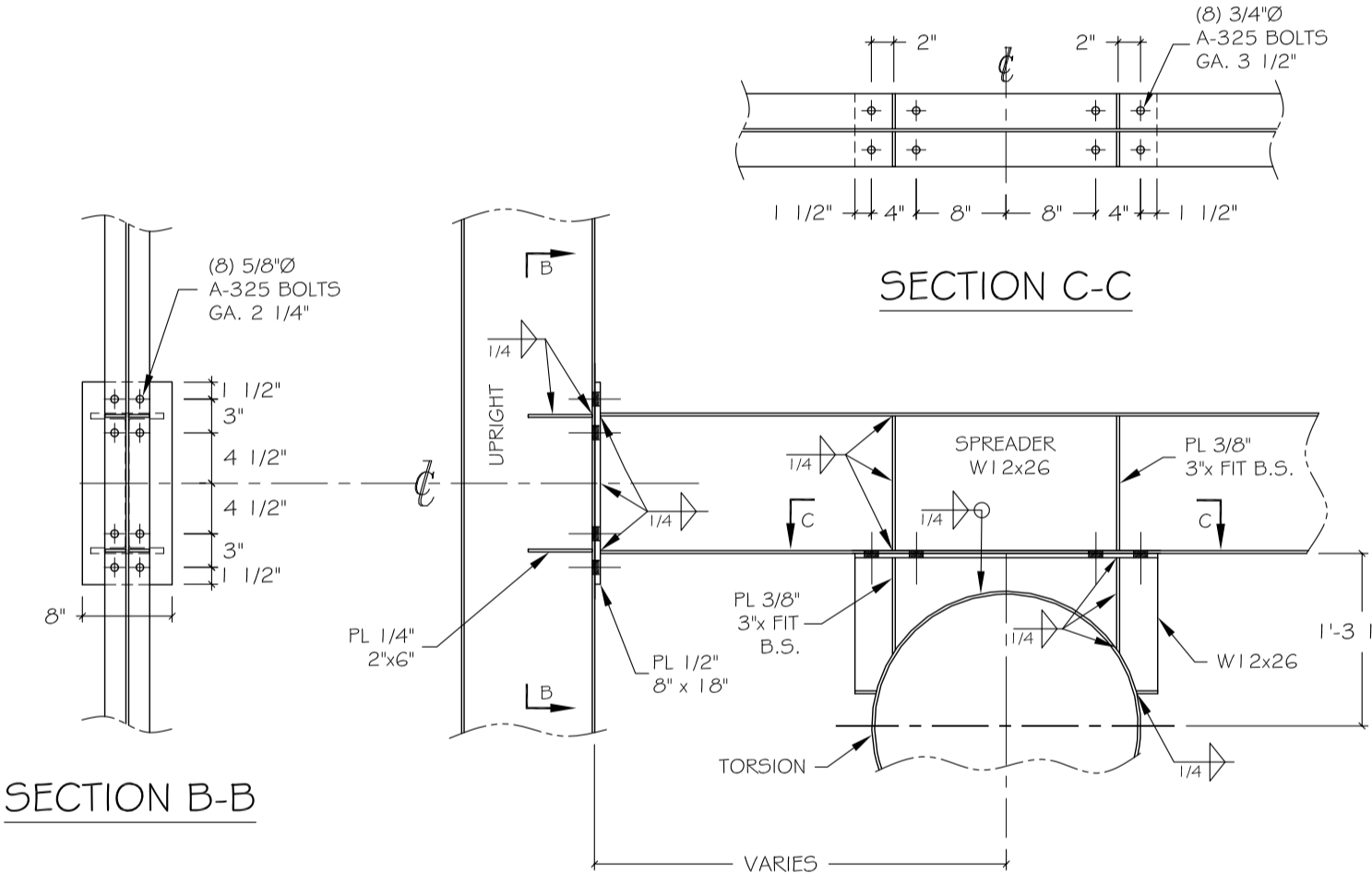

SECTION C-C

SECTION B-B

UPRIGHT-SPREADER-TORSION CONNECTION

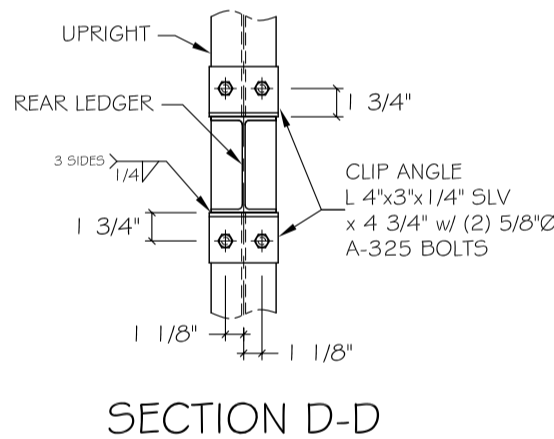

SECTION D-D

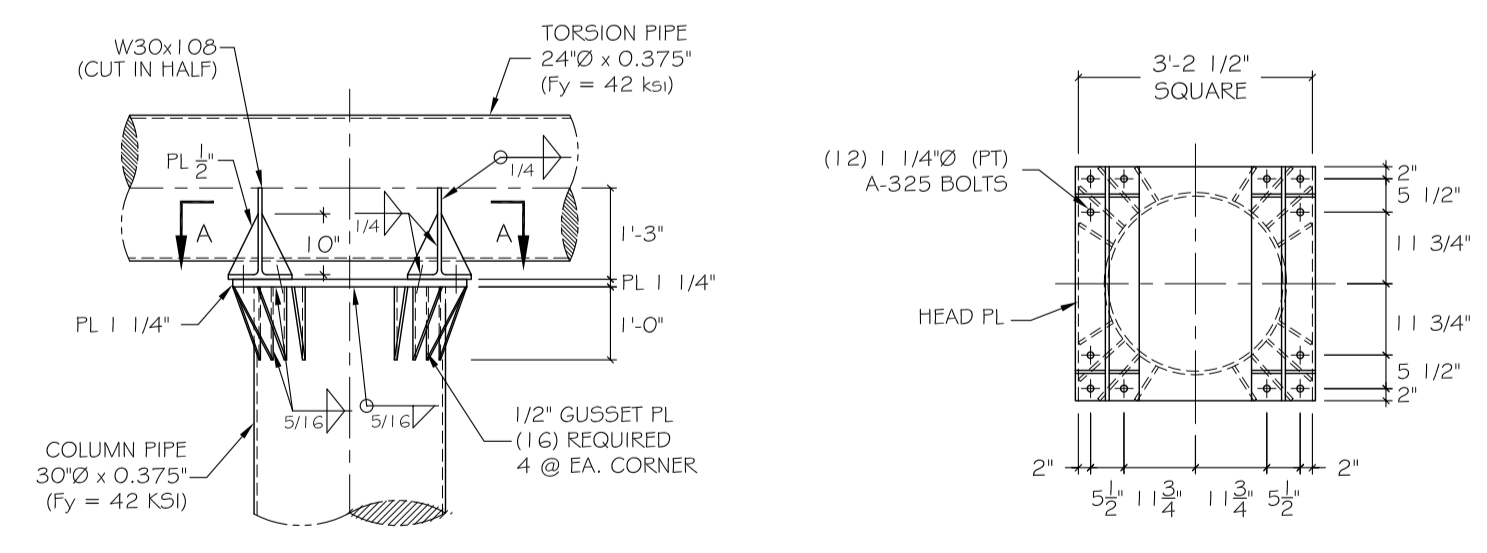

COLUMN-TORSION CONNECTION

SECTION A-A

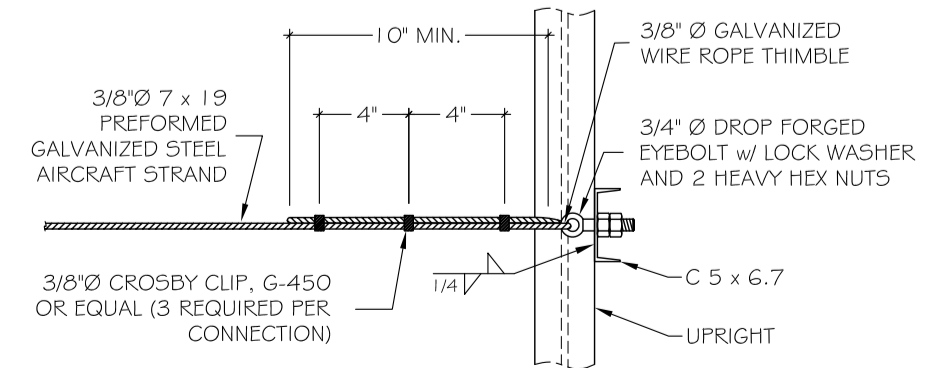

SAFETY CABLE MOUNTING

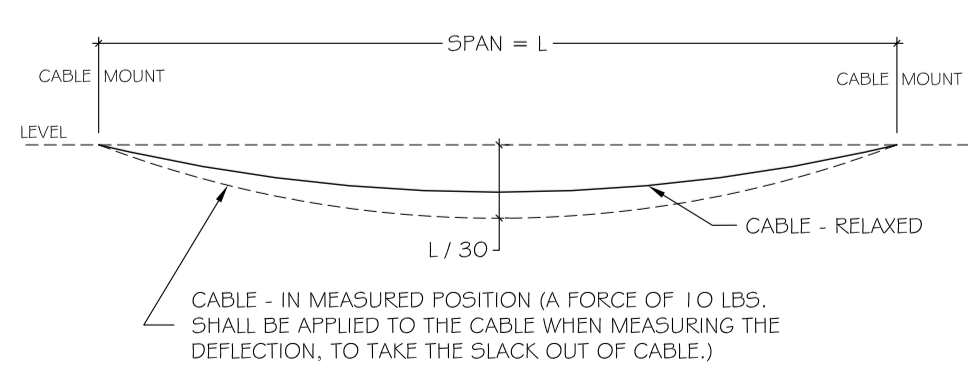

SAFETY CABLE TENSION

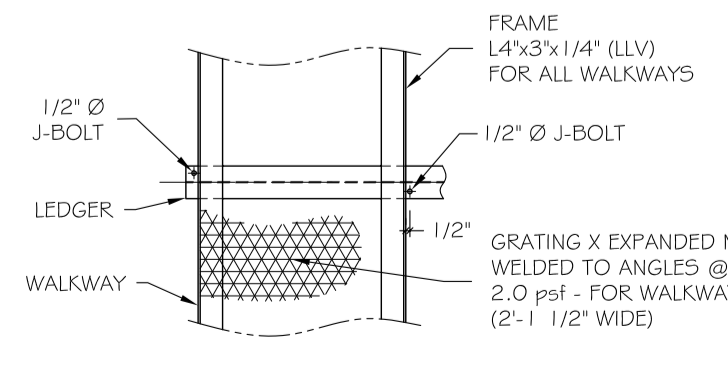

TYPICAL WALKWAY DETAIL

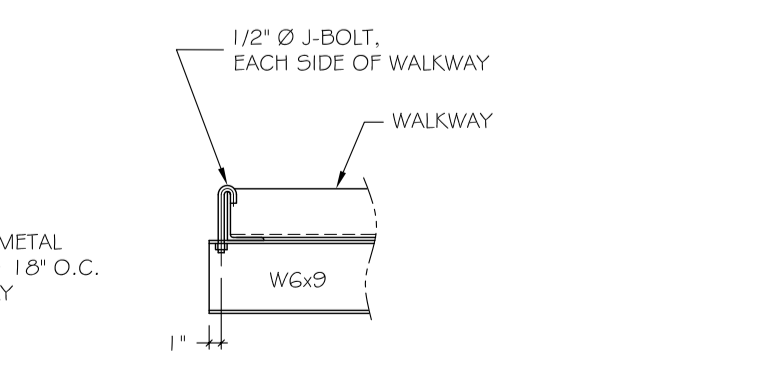

WALKWAY MOUNTING DETAIL

**FJS ENGINEERING** STRUCTURAL | CIVIL DESIGN | CONSULTING

FJS Engineering PROJ. NO. RMG0-23-105  
 Tucson, AZ  
 T: 520.490.3311  
 contact@fjsengineering.com

**RMG Outdoor Inc.**

4425 North 24th Street, Suite 200  
 Phoenix, Arizona 85016  
 Phn: (602) 230-8634 Fax: (602) 230-9071

THIS PRINT IS THE PROPERTY OF <b>RMG OUTDOOR, INC.</b> PROFESSIONAL SEAL VALID ONLY WHEN FABRICATED BY THE ABOVE. IT IS PROVIDED FOR PERMIT PURPOSES ONLY. ANY OTHER USE OR REPRODUCTION IS PROHIBITED WITHOUT WRITTEN AUTHORIZATION FROM <b>RMG OUTDOOR, INC.</b>			<b>Professional Engineer</b> I hereby certify that this plan, specification, or report was prepared by me or under my direct supervision and that I am a duly Licensed Professional Engineer under the laws of the state of Minnesota. Signature: Typed or Printed Name: John Skwiot Date: 05/31/2023 License Number: 46853		
CUSTOMER			IDIGITAL		
SIGN LOCATION			RAMSEY, MN		
12'-6" x 46' SINGLE POST CENTER MOUNT DOUBLE FACE 20° V-BUILD LED READY			ENG. NO.	DR.	CH.
			G-12311	DBM	JS
			DATE	05/31/2023	
JOB NO.			SHEET NO.	51 of 1	