

CITY OF RAMSEY

HALLS DOVER ACRES STREET RECONSTRUCTIONS

CITY IMPROVEMENT PROJECT NO. 24-02

GOVERNING SPECIFICATIONS

THE 2020 EDITION OF THE MINNESOTA DEPARTMENT OF TRANSPORTATION "STANDARD SPECIFICATIONS FOR CONSTRUCTION" SHALL GOVERN.

THE 2023 EDITION OF THE CITY ENGINEER'S ASSOCIATION OF MINNESOTA "STANDARD SPECIFICATIONS" SHALL GOVERN FOR MUNICIPAL UTILITY WORK.

ALL FEDERAL, STATE AND LOCAL LAWS, REGULATIONS AND ORDINANCES SHALL BE COMPLIED WITH IN THE CONSTRUCTION OF THIS PROJECT.

ALL TRAFFIC CONTROL DEVICES AND SIGNING SHALL CONFORM TO THE MINNESOTA MANUAL ON UNIFORM TRAFFIC CONTROL DEVICES, INCLUDING THE FIELD MANUAL FOR TEMPORARY TRAFFIC CONTROL ZONE LAYOUTS.

SHEET INDEX

THIS PLAN CONTAINS 65 SHEETS
SHEET No. DESCRIPTION

01	TITLE SHEET
02	STATEMENT OF ESTIMATED QUANTITIES
03	ALIGNMENT LAYOUT
04	TYPICAL SECTION
05-08	DETAILS
15	TRAFFIC CONTROL LAYOUT
16-17	SWPPP
18-24	EROSION CONTROL & GRADING
25-31	EXISTING CONDITIONS & REMOVALS
32-40	STREET & STORM SEWER
41	SUNFISH LAKE TRAIL & STORM SEWER
42-46	WATERMAIN CONSTRUCTION
47-53	RESTORATION
54-56	CROSS SECTIONS 157TH LANE
57-59	CROSS SECTIONS 158TH AVE & SODIUM ST
60-61	CROSS SECTIONS 158TH LANE
62-63	CROSS SECTIONS RADIUM STREET
64	CROSS SECTIONS RADIUM CIRCLE
65	CROSS SECTIONS RADIUM STREET STUB

LOCATION MAP

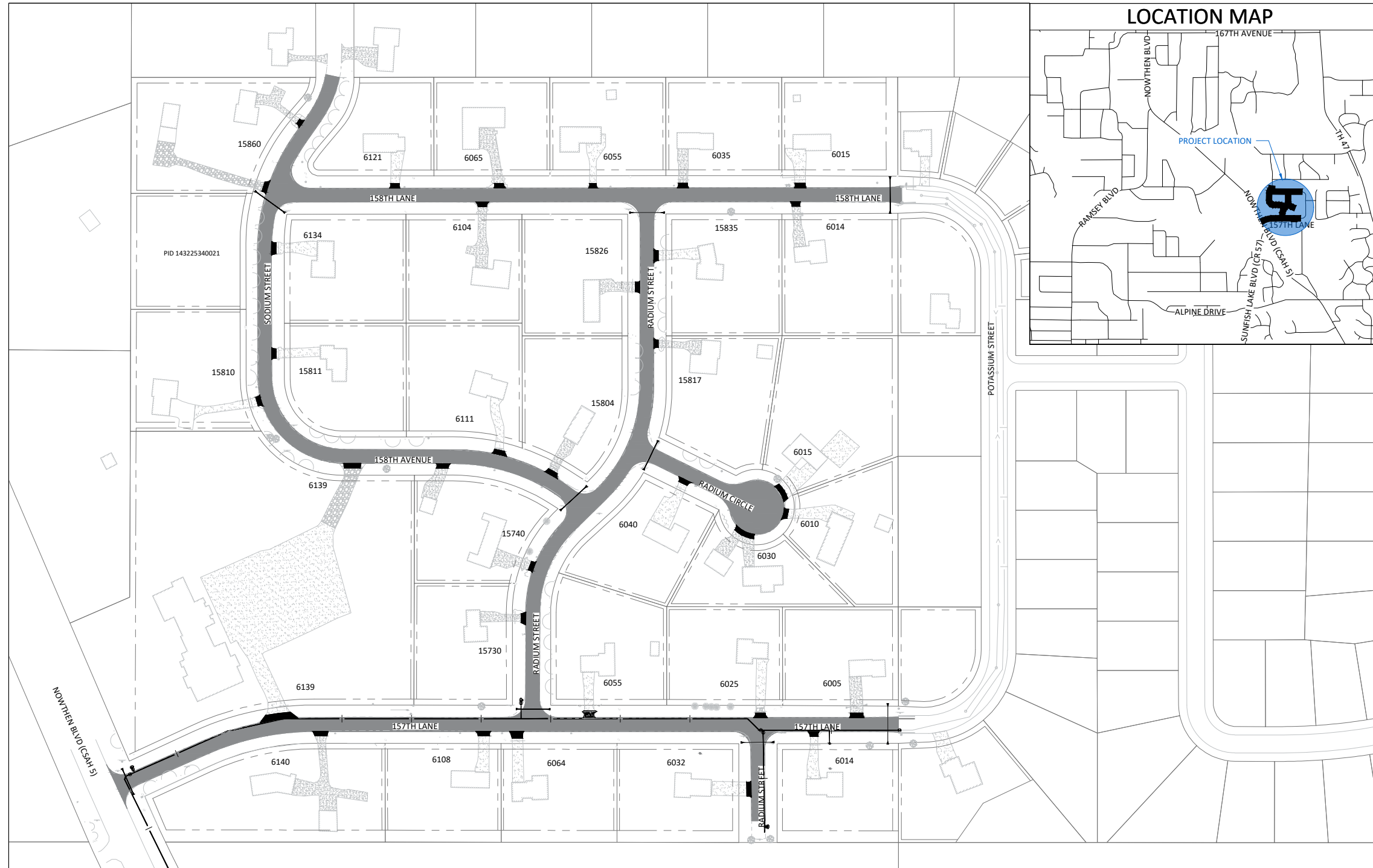
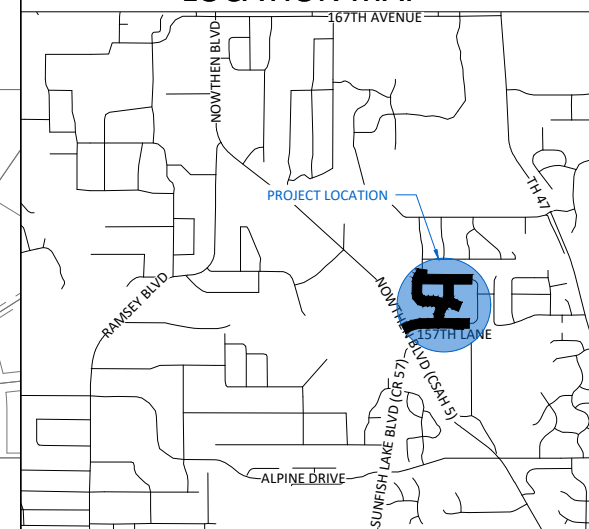

LEGEND

	SANITARY MANHOLE		Easement - Drainage & Utility
	STORM SEWER MANHOLE		Easement - Roadway
	CATCH BASIN MANHOLE		LOT LINE
	CATCH BASIN		ELECTRIC LINE
	CATCH BASIN - GROUT		ELECTRIC LINE - BURIED
	CATCH BASIN - RESET		ELECTRIC LINE - OVERHEAD
	FLARED END SECTION		GAS LINE
	CULVERT END SECTION		TELECOMMUNICATION LINE
	HYDRANT		TELECOMM - OVERHEAD
	VALVE		FIBER OPTIC LINE
	TREE - CONIFEROUS		TREE LINE
	TREE - DECIDUOUS		LANDSCAPE
	SHRUB		RETAINING WALL
	LIGHT POLE		FENCE
	SIGN		SILT FENCE
	MAILBOX		WATERMAIN
	PEDESTAL - TELECOM		SANITARY SEWER
	PEDESTAL - ELECTRIC		STORM SEWER
	HAND HOLE		DRAIN TILE
	DRIVE - BITUMINOUS		LANDSCAPE - ROCK
	DRIVE - CONCRETE		LANDSCAPE - MULCH
	DRIVE - GRAVEL		LANDSCAPE - RIP RAP
	CONCRETE WALK		PR. DRIVE - BITUMINOUS
	BITUMINOUS TRAIL		PR. DRIVE - CONCRETE
	REMOVE BIT PAVE		PR. DRIVE - GRAVEL
	REMOVE CONCRETE PAVE		PR. CONCRETE WALK
	REMOVE GRAVEL SURFACE		PR. CONCRETE
	MILL BIT PAVEMENT		PR. SEEDING AREA
	RECLAIM BIT PAVEMENT		PR. SODDING AREA

I hereby certify that this plan, specification, or report was prepared by me or under my direct supervision and that I am a duly Licensed Professional Engineer under the laws of the State of Minnesota.

JOE FERIANCEK, P.E.
 ASSISTANT CITY ENGINEER

57095 DATE 1/23/24
 LIC. NO.

DATE	REVISION
3/06/24	REVISE TRAFFIC CONTROL
3/28/24	ADD 1" WATER SERVICE - 6014 157TH LN.

SHEET 01 OF 65 SHEETS

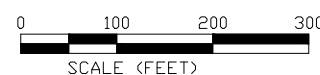

CITY OF RAMSEY
 7550 SUNWOOD DRIVE
 RAMSEY, MN 55303
 (763) 427-1410 FAX (763) 433-9898

THE SUBSURFACE UTILITY INFORMATION IN THIS PLAN IS UTILITY QUALITY LEVEL D. THIS QUALITY LEVEL WAS DETERMINED ACCORDING TO THE GUIDELINES OF CI/ASCE 38-02, ENTITLED "STANDARD GUIDELINES FOR THE COLLECTION AND DEPICTION OF EXISTING SUBSURFACE UTILITY DATA."

NOTE: EXISTING UTILITY INFORMATION SHOWN ON THIS PLAN HAS BEEN PROVIDED BY THE UTILITY OWNER. THE CONTRACTOR SHALL FIELD VERIFY EXACT LOCATIONS PRIOR TO COMMENCING CONSTRUCTION AS REQUIRED BY STATE LAW. NOTIFY GOPHER STATE ONE CALL 1-800-252-1166 OR 651-454-0002



Call before you dig
 811
 651 454-0002 Metro
 800 252-1166 Outstate
www.gopherstateonecall.org

24-02 HALLS DOVER ACRES STREET RECONSTRUCTION								
STATEMENT OF ESTIMATED QUANTITIES								
NOTES	ITEM NO.	MNDOT SPEC NO.	ITEM DESCRIPTION	UNIT	TOTAL	STREET	STORM	WATER
	1	2021.501	MOBILIZATION	LS	1.00	0.6	0.05	0.35
	2	2101.502	CLEARING	EA	6			6
	3	2101.502	GRUBBING	EA	6			6
11	4	2104.502	SALVAGE MAIL BOX SUPPORT	EA	28	28		
1	5	2104.503	SAWING PAVEMENT (FULL DEPTH)	LF	823	697		126
1	6	2104.503	REMOVE WATERMAIN	LF	15			15
1	7	2104.504	REMOVE BITUMINOUS PAVEMENT	SY	1022	382		640
1	8	2104.504	REMOVE CONCRETE PAVEMENT	SY	205	205		
1	9	2104.504	REMOVE AGGREGATE SURFACING	SY	79	79		
	10	2104.602	LANDSCAPE RESTORATION	EA	15	15		
14	11	2106.507	EXCAVATION - COMMON (EV)	CY	834	834		
2, 13	12	2106.607	HAUL & STOCKPILE RECLAIM MATERIAL (LV)	CY	1495	1495		
	13	2112.519	SUBGRADE PREPARATION - ROADWAY	RDST	41	41		
15	14	2112.604	SUBGRADE PREPARATION	SY	609			609
	15	2123.61	STREET SWEEPER (WITH PICKUP BROOM)	hour	24	20		4
	16	2130.523	WATER	MGAL	82	82		
2	17	2211.507	AGGREGATE BASE CLASS 5 MODIFIED (CV)	CY	1789	1709		80
2	18	2211.604	AGGREGATE BASE CLASS 5 SURFACING - DRIVEWAYS	SY	97	97		
1, 13	19	2215.504	FULL DEPTH RECLAMATION	SY	14351	14351		
1	20	2232.504	MILL BITUMINOUS PAVEMENT 2.0"	SY	55	33		22
	21	2301.604	CONCRETE PAVEMENT DRIVEWAYS 6.0"	SY	225	225		
4	22	2357.506	BITUMINOUS MATERIAL FOR TACK COAT	GAL	1032	1017		15
5	23	2360.509	TYPE SP 12.5 NON WEARING COURSE MIXTURE (3,C)	TON	1653	1641		12
5	24	2360.509	TYPE SP 9.5 WEARING COURSE MIXTURE (3,C)	TON	1218	1206		12
5	25	2360.509	TYPE SP 9.5 WEARING COURSE MIXTURE (3,C) DRIVEWAYS	TON	41	41		
5	26	2360.509	TYPE SP 9.5 WEARING COURSE MIXTURE (3,C) TRAIL	TON	71			71
	27	2501.502	15" RC PIPE APRON	EA	18		18	
	28	2501.502	18" CS PIPE APRON	EA	1		1	
	29	2503.503	15" RC PIPE SEWER DESIGN 3006 CLASS III	LF	459		459	
	30	2503.503	18" CMP PIPE SEWER	LF	37		37	
	31	2504.602	6" GATE VALVE & BOX	EA	5			5
	32	2504.602	8" GATE VALVE & BOX	EA	2			2
	33	2504.602	12" GATE VALVE & BOX	EA	3			3
	34	2504.602	ADJUST VALVE BOX	EA	10			10
	35	2504.602	CONNECT TO EXISTING WATERMAIN	EA	2			2
	36	2504.602	HYDRANT (8.5' BURY)	EA	5			5
	37	2504.602	8" WATERMAIN PLUG	EA	1			1
	38	2504.603	6" WATERMAIN DUCTILE IRON CL 53	LF	64			64
	39	2504.603	8" WATERMAIN PVC (C900)	LF	412			412
	40	2504.603	12" WATERMAIN PVC (C900)	LF	2165			2165
	41	2504.608	WATERMAIN FITTINGS	LBS	1676			1676
	42	2521.504	6" CONCRETE WALK	SY	10			10
	43	2521.602	DRILL & GROUT REINF BAR (EPOXY COATED)	EA	4			4
	44	2531.618	TRUNCATED DOMES	SF	21			21
	45	2540.602	TEMPORARY MAIL BOX CLUSTER	EA	2	2		
11	46	2540.602	INSTALL MAIL BOX SUPPORT	EA	28	28		
12	47	2563.601	TRAFFIC CONTROL	LS	1.0	0.25		0.75
	48	2572.503	TEMPORARY TREE PROTECTION FENCE	LF	20	20		
	49	2573.602	STABILIZED CONSTRUCTION EXIT	EA	4	4		
	50	2573.502	STORM DRAIN INLET PROTECTION	EA	2	2		
	51	2573.503	SEDIMENT CONTROL LOG TYPE STRAW	LF	575		575	
	52	2573.503	SILT FENCE; TYPE MS	LF	2921	1238		1683
3	53	2574.507	TOPSOIL (LV)	CY	1394	1085		309
9	54	2574.508	FERTILIZER TYPE 3	LBS	398	310		88
	55	2575.504	ROLLED EROSION PREVENTION CATEGORY 20	SY	2234	498		1736
	56	2575.505	SEEDING	ACRE	1.99	1.55		0.44
10	57	2575.508	HYDRAULIC MULCH MATRIX	LBS	6100	5780		320
7	58	2575.508	SEED MIXTURE 25-141	LBS	24	2		22
8	59	2575.508	SEED MIXTURE 25-151	LBS	322	306		16
	60	2582.503	4" DOUBLE SOLID LINE PAINT (EPOXY)	LF	16			16
	61	2582.503	4" SOLID LINE PAINT (EPOXY)	LF	43			43
	CO 62	2504.602	1" CORPORATION STOP	EA	1			1
	CO 63	2504.602	1" CURB STOP AND BOX	EA	1			1
	CO 64	2504.603	1" COPPER PIPE TYPE K	LF	23			23

PAY ITEM NOTES:

- REMOVAL LIMITS SHALL BE MARKED IN THE FIELD BY CITY STAFF.
- LV TO CV CONVERSION FACTOR = 1.25.
- LV TO CV CONVERSION FACTOR = 1.30.
- ESTIMATED QUANTITY BASED ON APPLICATION RATE OF 0.07 GAL/SY.
- ESTIMATED QUANTITY BASED ON APPLICATION RATE OF 113 LB/SY-IN.
- ESTIMATED QUANTITY BASED ON U.S. PIPE MECHANICAL JOINT FITTINGS TABLES.
- ESTIMATED QUANTITY BASED ON 59 LB/ACRE.
- ESTIMATED QUANTITY BASED ON 200 LB/ACRE.
- ESTIMATED QUANTITY BASED ON 200 LB/ACRE.
- ESTIMATED QUANTITY BASED ON 4000 LB/ACRE.
- PAY ITEM INCLUDES ALL EXISTING MAILBOX SUPPORTS, REGARDLESS OF MATERIAL(S), SIZE, FOOTING TYPE, LOCATION, OR EXISTING ELECTRICAL SERVICE.
- LUMP SUM QUANTITY SHALL INCLUDE ALL COST REQUIRED FOR MAINTAINING ALL FLAGGING OPERATIONS AS NECESSARY, MAINTAINING PEDESTRIAN ACCESS ROUTES, ANY SIGNAGE AND BARRICADES AS NECESSARY, INCLUDING FOR ANY DETOUR ROUTES.
- EXCESS RECLAMATION MATERIAL SHALL BE HAULED TO 16600 SAINT FRANCIS BOULEVARD. THE EXPECTED RECLAMATION DEPTH IS 8 INCHES. THE TOP 2.5 INCHES ARE PROPOSED TO BE REMOVED. THE CONTRACTOR IS RESPONSIBLE FOR PROVIDING ALL EQUIPMENT AND PERSONAL REQUIRED TO HAUL AND STOCKPILE THE RECLAMATION MATERIAL.
- COMMON EXCAVATION INCLUDES REMOVAL OF EXISTING 4-INCHES OF MATERIAL IN ALL DISTURBED AREAS, AS REQUIRED TO PLACE 4-INCHES OF TOPSOIL IN DISTURBED AREAS. THE EXCAVATION REQUIRED FOR UTILITY INSTALLATION IS INCIDENTAL TO THE UTILITY PAY ITEM.
- SUBGRADE PREPARATION FOR BITUMINOUS TRAIL AND COUNTY ROAD PATCH AREAS.

GENERAL NOTES:

- THE LOCATIONS OF EXISTING UNDERGROUND UTILITIES ARE SHOWN IN AN APPROXIMATE WAY ONLY. IT IS NOT GUARANTEED ANY OR ALL EXISTING UTILITIES ARE SHOWN. THE CONTRACTOR SHALL DETERMINE THE EXACT LOCATION OF ALL EXISTING UTILITIES BEFORE COMMENCING WORK. HE AGREES TO BE FULLY RESPONSIBLE FOR ANY AND ALL DAMAGES WHICH MIGHT BE OCCASIONED BY HIS FAILURE TO EXACTLY LOCATE AND PRESERVE ANY AND ALL UNDERGROUND UTILITIES.
- THE CONTRACTOR SHALL DETERMINE THE EXACT LOCATION OF ALL EXISTING IRRIGATION SYSTEMS WITHIN THE PROJECT CONSTRUCTION LIMITS BEFORE COMMENCING WORK. THE CONTRACTOR IS RESPONSIBLE FOR AVOIDING DAMAGE TO IRRIGATION SYSTEMS WHERE POSSIBLE.
- SALVAGE AND INSTALL MAILBOX SUPPORTS IN THE SAME LOCATION, UNLESS OTHERWISE DIRECTED. THE INSTALLATION WILL BE THE SAME TYPE AS ORIGINAL INSTALLATION. CONTRACTOR SHALL BE RESPONSIBLE FOR REPLACING MAILBOX SUPPORTS WHICH ARE DAMAGED DURING SALVAGE AND/OR INSTALLATION UNLESS CONTRACTOR NOTIFIES CITY OF DAMAGED MAILBOX SUPPORTS BEFORE SALVAGE OPERATIONS BEGIN. SALVAGED MAILBOX SUPPORTS SHALL BE STORED BY CONTRACTOR DURING PROJECT.
- PERMANENT SIGN REMOVAL AND INSTALLATION IS TO BE PERFORMED BY CITY OF RAMSEY PUBLIC WORKS DEPARTMENT.

WATERMAIN TABULATION					
STRUCTURE STATION	HYDRANT EACH	VALVE SIZE	BEND		NOTE
			TYPE	SIZE	
0+04.00		12" GV			CONNECT TO EXISTING WATERMAIN
0+07.00			45° ELBOW	12"	
0+11.20			45° ELBOW	12"	
1+84.00	HYDRANT	6" GV	TEE	12" X 6"	HYDRANT AT R 6.0'
4+27.24			22.5° ELBOW	12"	
5+28.56			22.5° ELBOW	12"	
6+02.63			45° ELBOW	12"	
6+08.29			45° ELBOW	12"	
6+23.00	HYDRANT	6" GV	TEE	12" X 6"	HYDRANT AT R 9.6'
10+36.90			45° ELBOW	12"	
10+42.44			45° ELBOW	12"	
10+50.44		12" GV			
10+58.52	HYDRANT	6" GV	TEE	12" X 6"	HYDRANT AT R 10.0'
12+35.02			11.25° ELBOW	12"	
13+34.45			11.25° ELBOW	12"	
17+42.83	HYDRANT	6" GV	TEE	12" X 6"	HYDRANT AT L 31.9'
21+33.88			45° ELBOW	12"	
21+61.67			45° ELBOW	12"	
21+64.67		12" GV			

STRUCTURE STATION	HYDRANT EACH	VALVE SIZE	BEND		NOTE
			TYPE	SIZE	
21+68.67			TEE	12" X 8"	TEE TO RADIUM STREET STUB
21+71.67			REDUCER	12" X 8"	
22+83.21					1" CORPORATION STOP
24+03.91		8" GV			CONNECT TO EXISTING WATERMAIN
WATERMAIN TABULATION - RADIUM STREET STUB					
0+04		8" GV			
1+66.54	HYDRANT	6" GV	TEE	8" X 6"	HYDRANT AT L 6.0'
1+76.54			PLUG	8"	PLUG END OF WATERMAIN

DATE	REVISION
3/28/24	ADD 1" WATER SERVICE - 6014 157TH LN.

I hereby certify that this plan, specification, or report was prepared by me or under my direct supervision and that I am a duly Licensed Professional Engineer under the laws of the State of Minnesota

Joe Feriancek
 JOE FERIANCEK
 Date: 4/23/24 Lic. No. 57095

DESIGNED BY:	JJF
DRAWN BY:	JJF
CHECKED BY:	BRW

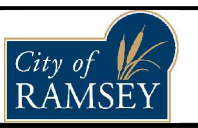

CITY OF RAMSEY
 7550 SUNWOOD DRIVE
 RAMSEY, MN 55303
 (763) 427-1410 FAX (763) 433-9898

STATEMENT OF ESTIMATED QUANTITIES

HALLS DOVER ACRES STREET RECONSTRUCTIONS
 CITY PROJECT NO. 24-02
 CITY OF RAMSEY, MINNESOTA

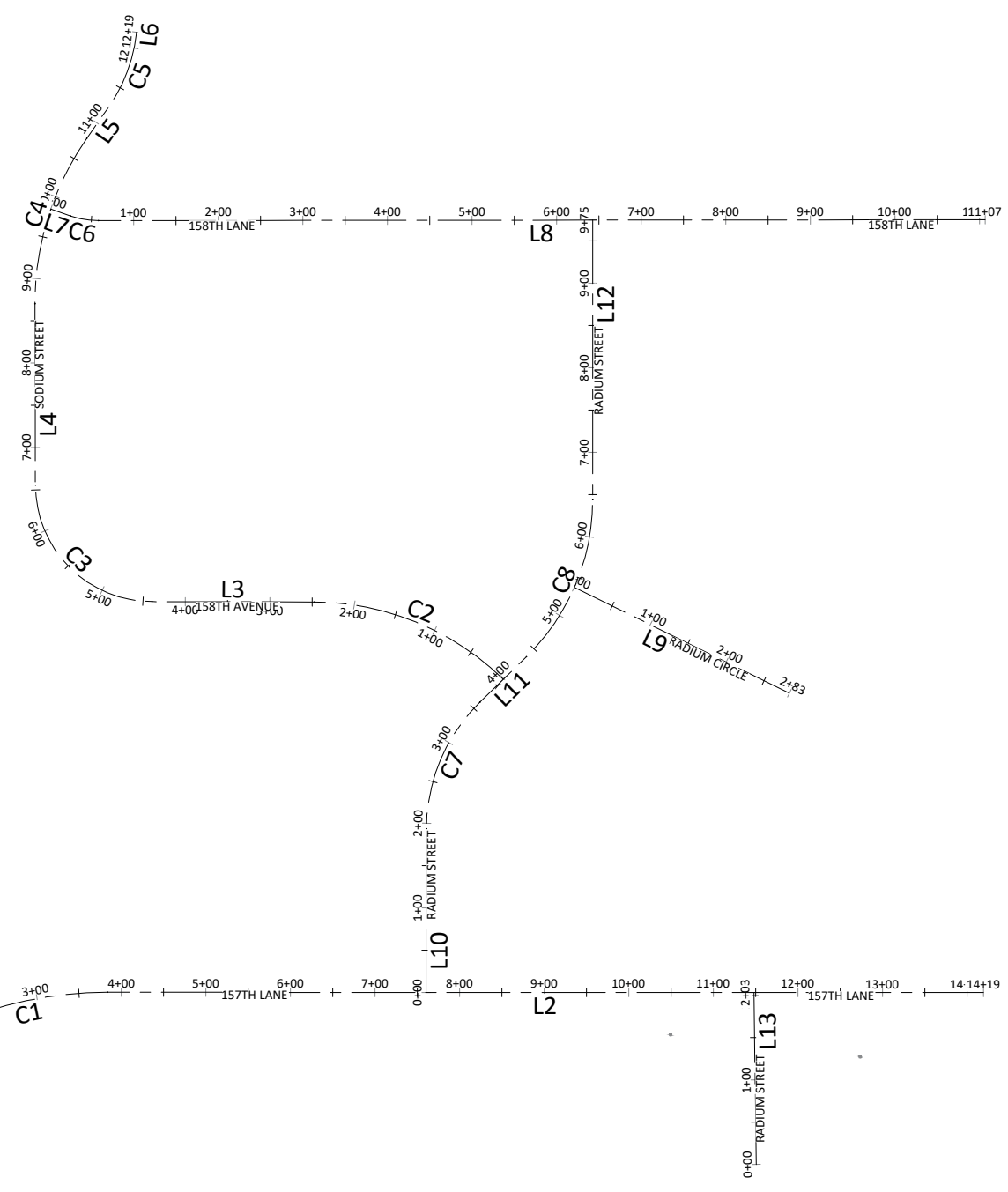

Line Table: Alignments				
Line #	Length	Direction	Start Point	End Point
L1	189.999	N66° 09' 25.27"E	(459355.2462,180473.7540)	(459529.0305,180550.5578)
L2	1035.703	S89° 59' 15.21"E	(459717.0992,180590.2424)	(460752.8025,180590.0175)
L7	24.994	S70° 56' 20.64"E	(459650.0416,181516.3655)	(459673.6650,181508.2031)
L8	1048.313	N89° 56' 44.59"E	(459706.4171,181502.7204)	(460754.7295,181503.7135)
L9	283.262	S63° 45' 44.70"E	(460269.0984,181069.2056)	(460523.1755,180943.9770)
L13	203.281	N00° 45' 01.42"W	(460484.0360,180386.8128)	(460481.3738,180590.0764)
L3	191.881	N89° 53' 14.55"W	(459961.5508,181051.8457)	(459769.6702,181052.2229)
L4	214.599	N00° 08' 39.81"W	(459631.9419,181189.8748)	(459631.4011,181404.4736)
L5	44.960	N34° 56' 23.93"E	(459692.6841,181600.0546)	(459718.4334,181636.9105)
L6	0.724	N06° 21' 22.62"E	(459751.5125,181724.6919)	(459751.5926,181725.4109)
L10	193.680	N00° 09' 27.94"E	(460093.6955,180590.1606)	(460094.2288,180783.8395)
L11	76.755	N45° 40' 55.62"E	(460157.5138,180933.5110)	(460212.4299,180987.1348)
L12	330.228	N00° 01' 28.83"E	(460290.7838,181173.0462)	(460290.9260,181503.2741)

Curve Table: Alignments					
Curve #	Radius	Length	Chord Direction	Start Point	End Point
C1	465.000	193.605	N78° 05' 05.03"E	(459529.0305,180550.5578)	(459717.0992,180590.2424)
C2	320.000	247.568	N67° 43' 26.05"W	(460184.9719,180960.3229)	(459961.5508,181051.8457)
C3	138.000	216.151	N45° 00' 57.18"W	(459769.6702,181052.2229)	(459631.9419,181189.8748)
C7	210.000	166.855	N22° 55' 11.78"E	(460094.2288,180783.8395)	(460157.5138,180933.5110)
C8	260.000	207.187	N22° 51' 12.22"E	(460212.4299,180987.1348)	(460290.7838,181173.0462)

DATE	REVISION

I hereby certify that this plan, specification, or report was prepared by me or under my direct supervision and that I am a duly Licensed Professional Engineer under the laws of the State of Minnesota.

Joe Feriancek
JOE FERIANCEK
Date 1/23/24 Lic. No. 57095

DESIGNED BY: JJF
DRAWN BY: JJF
CHECKED BY: BRW

DATE: 12/15/23
FILE: 24-02

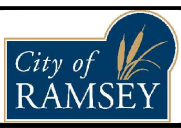

CITY OF RAMSEY
7550 SUNWOOD DRIVE
RAMSEY, MN 55303
(763) 427-1410 FAX (763) 433-9898

ALIGNMENT LAYOUT

HALLS DOVER ACRES STREET RECONSTRUCTIONS
CITY PROJECT NO. 24-02
CITY OF RAMSEY, MINNESOTA

TYPICAL SECTION: CITY STREETS

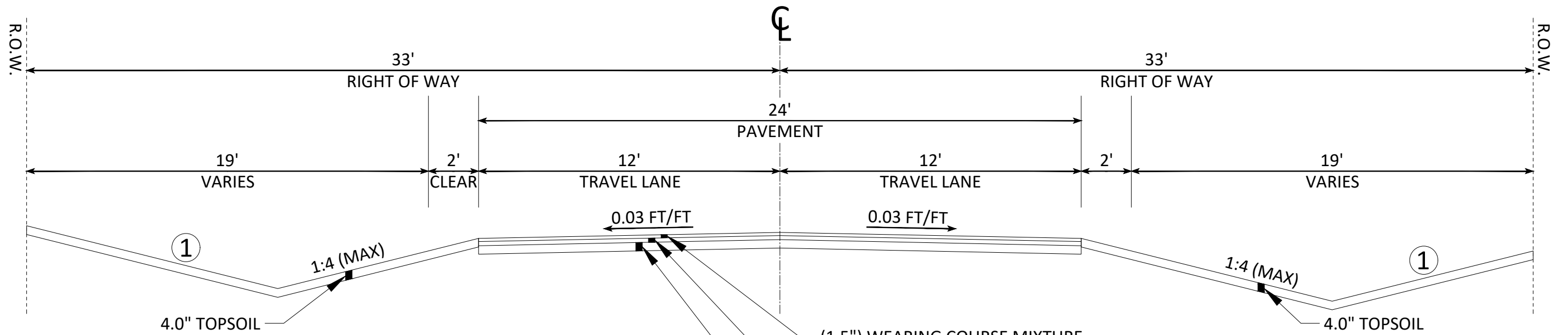

REFERENCE NOTES:

- ① GRADE TO MATCH EXISTING GROUND. ESTABLISH TURF USING A MINIMUM OF 4" TOPSOIL AND HYDROSEED WITH MNDOT SEED MIXTURE 25-151. SEE CITY DETAIL ERO-6 FOR TOPSOIL REQUIREMENTS.
- ② MODIFY CLASS 5 AGGREGATE BASE PER CITY STANDARD DETAIL STR-26. SEE SHEET 09. RECYCLED RECLAMATION MATERIAL MEETING STR-26 MAY BE USED AS AGGREGATE BASE.
- ③ CONTRACTOR SHALL SCARIFY AND COMPACT, ACCORDING TO THE SPECIFIED DENSITY METHOD, THE TOP 12 INCHES OF MATERIAL PRIOR TO PLACING CLASS 5 AGGREGATE BASE. THIS PROCESS SHALL BE INCIDENTAL TO THE SUBGRADE PREPARATION PAY ITEM.

- (1.5") WEARING COURSE MIXTURE
RECYCLED AGGREGATE ALLOWED
- (2.0") NON WEARING COURSE MIXTURE
RECYCLED AGGREGATE ALLOWED
- (4.0") CLASS 5 AGGREGATE BASE ②

SECTION A: NOWTHEN BOULEVARD

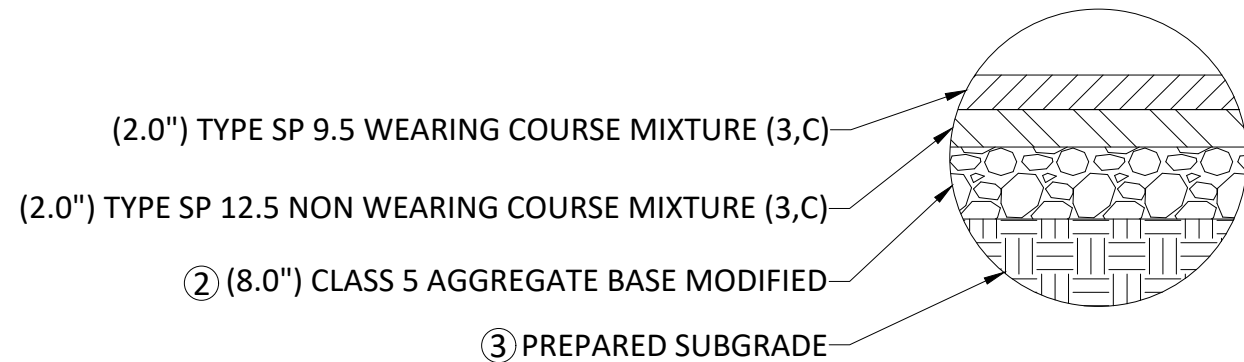

SECTION B: TRAIL

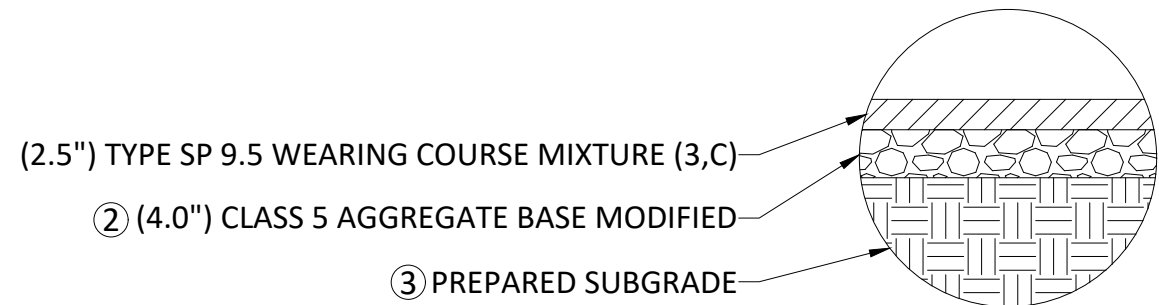

DATE	REVISION

I hereby certify that this plan, specification, or report was prepared by me or under my direct supervision and that I am a duly Licensed Professional Engineer Under the laws of the State of Minnesota.

Joe Feriancek
 JOE FERIANCEK
 Date: 1/23/24 Lic. No. 57095

DESIGNED BY: JJF
 DRAWN BY: JJF
 CHECKED BY: BRW

DATE: 12/15/23
 FILE: 24-02

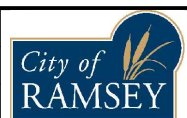

CITY OF RAMSEY
 7550 SUNWOOD DRIVE
 RAMSEY, MN 55303
 (763) 427-1410 FAX (763) 433-9898

TYPICAL SECTION

HALLS DOVER ACRES STREET RECONSTRUCTIONS
 CITY PROJECT NO. 24-02
 CITY OF RAMSEY, MINNESOTA

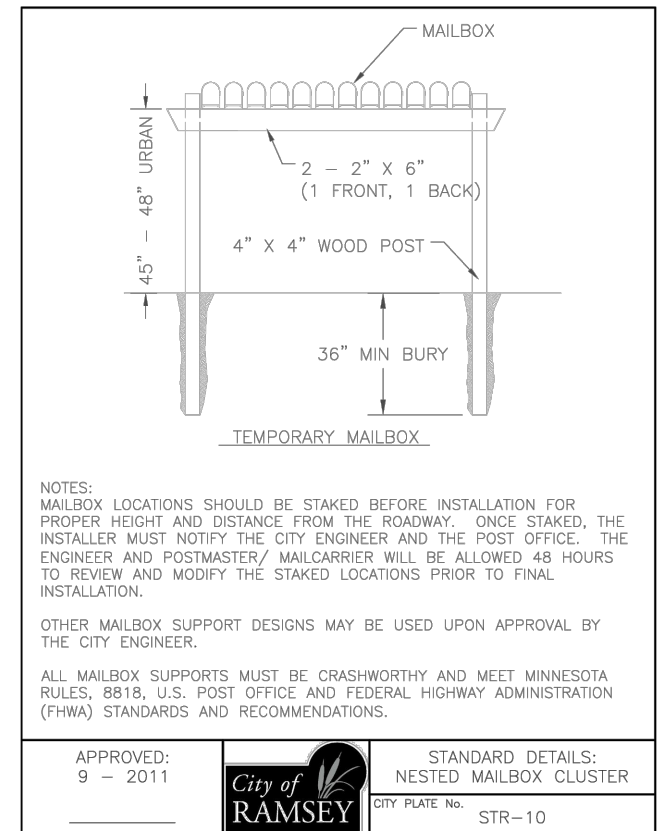
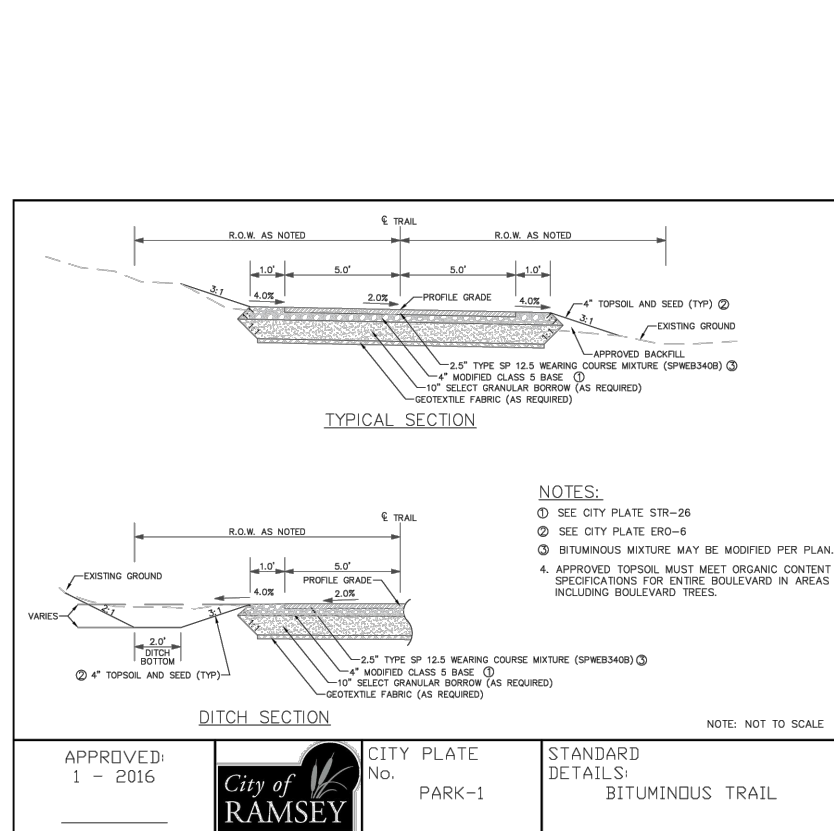
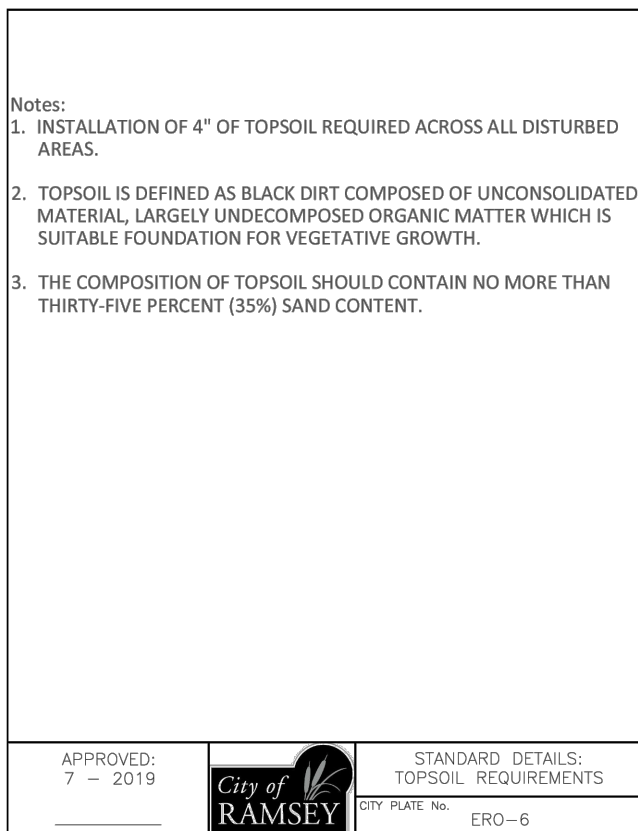
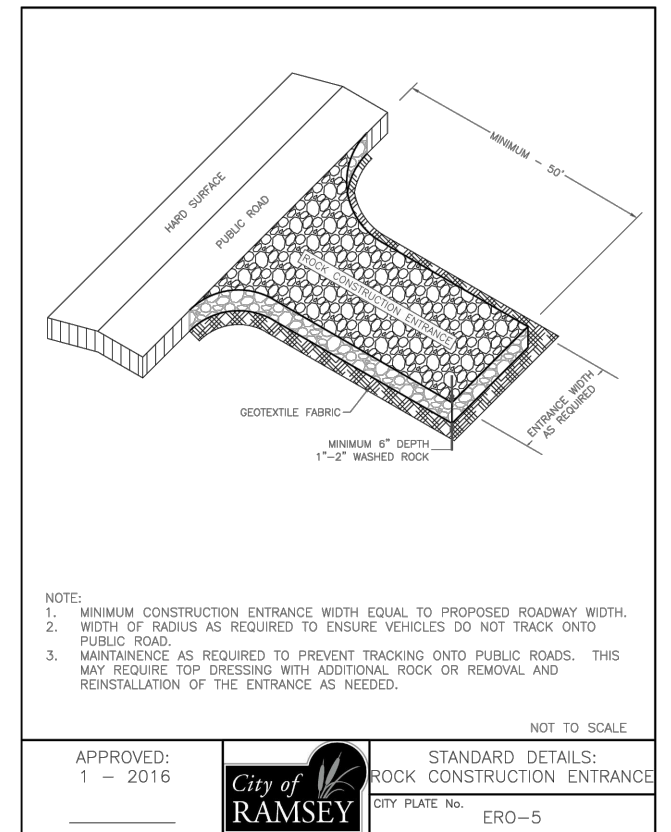
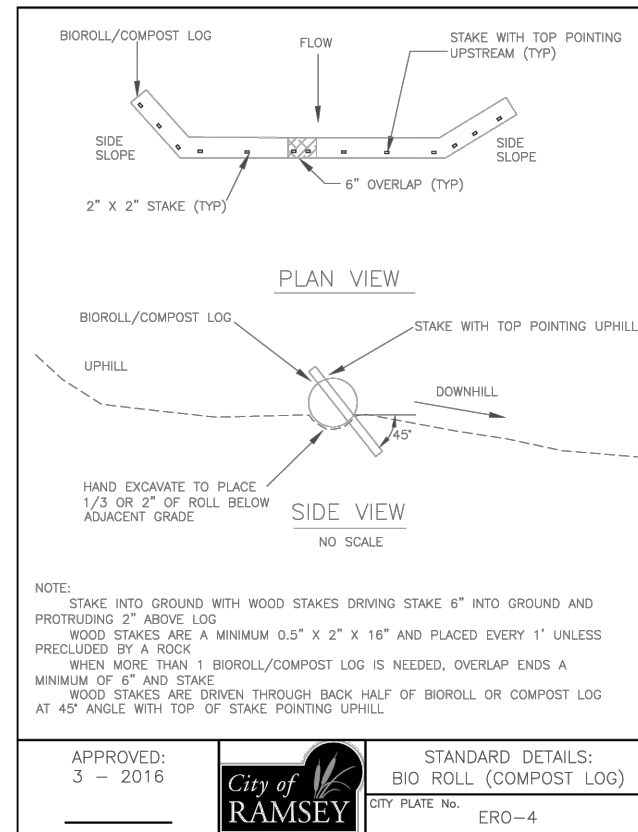
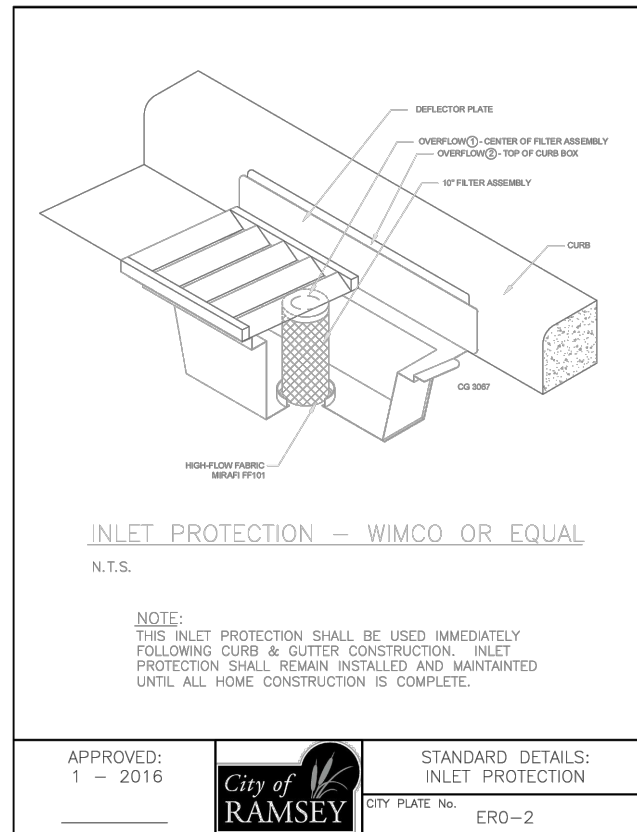
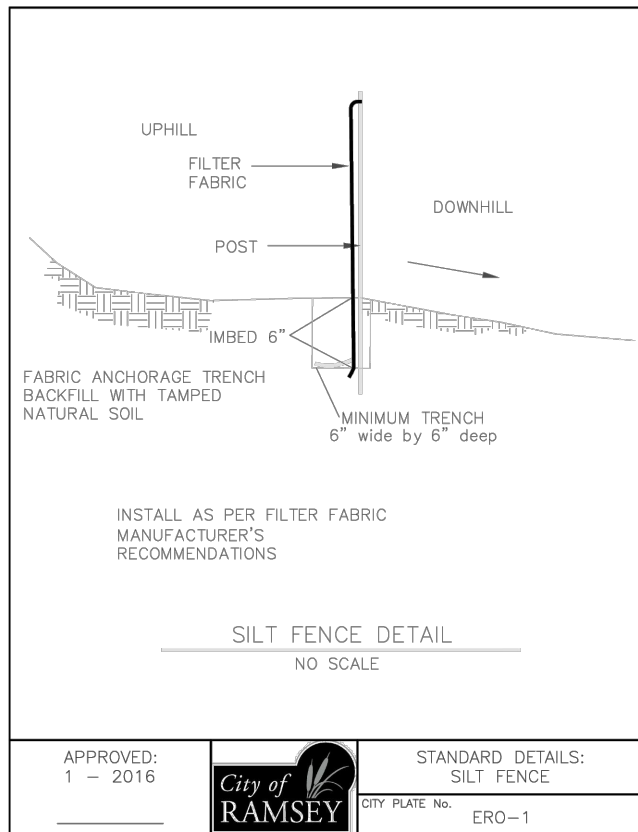

DATE	REVISION

I hereby certify that this plan, specification, or report was prepared by me or under my direct supervision and that I am a duly Licensed Professional Engineer Under the laws of the State of Minnesota

Joe Feriancek
JOE FERIANCEK
Date 1/23/24 Lic. No. 57095

DESIGNED BY: JJF
DRAWN BY: JJF
CHECKED BY: BRW

DATE: 12/15/23
FILE: 24-02

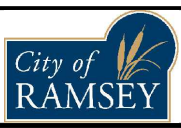

CITY OF RAMSEY
7550 SUNWOOD DRIVE
RAMSEY, MN 55303
(763) 427-1410 FAX (763) 433-9898

DETAILS

HALLS DOVER ACRES STREET RECONSTRUCTIONS
CITY PROJECT NO. 24-02
CITY OF RAMSEY, MINNESOTA

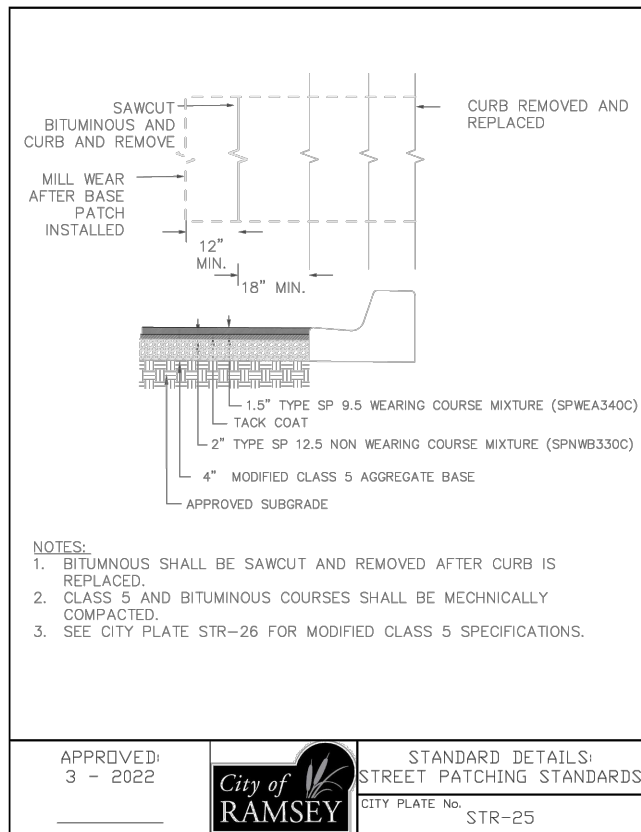

TABLE A MODIFIED CLASS 5 SPECIFICATIONS

% PASSING

1"	100
3/4"	90 - 100
3/8"	50 - 80
No.4	35 - 70
No.10	20 - 60
No.40	10 - 35
No.200	5 - 10

NOTES:

1. THE AGGREGATE BASE CONSTRUCTION WILL BE ACCEPTED FOR PAYMENT IN ACCORDANCE WITH THE PROVISIONS IN TABLE A.
2. IF THE AGGREGATE BASE FAILS TO MEET THE REQUIREMENTS OF TABLE A THE MATERIAL CAN BE CORRECTED IN PLACE OR REMOVED AND REPLACED WITH MATERIAL THAT MEET THE REQUIREMENTS OF TABLE A.
3. IN THE EVENT THAT RECYCLED MATERIAL IS USE IT MUST MEET MNDOT REQUIREMENTS FOR RECYCLED BASE.

APPROVED: 2 - 2003

City of RAMSEY

STANDARD DETAILS: MODIFIED CLASS 5 SPECIFICATIONS
CITY PLATE No. STR-26

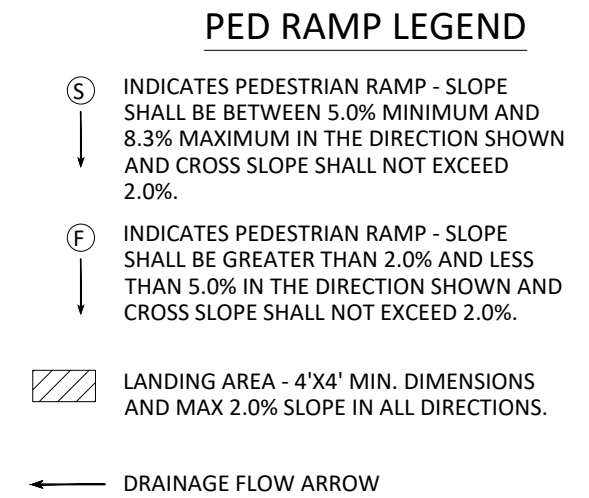
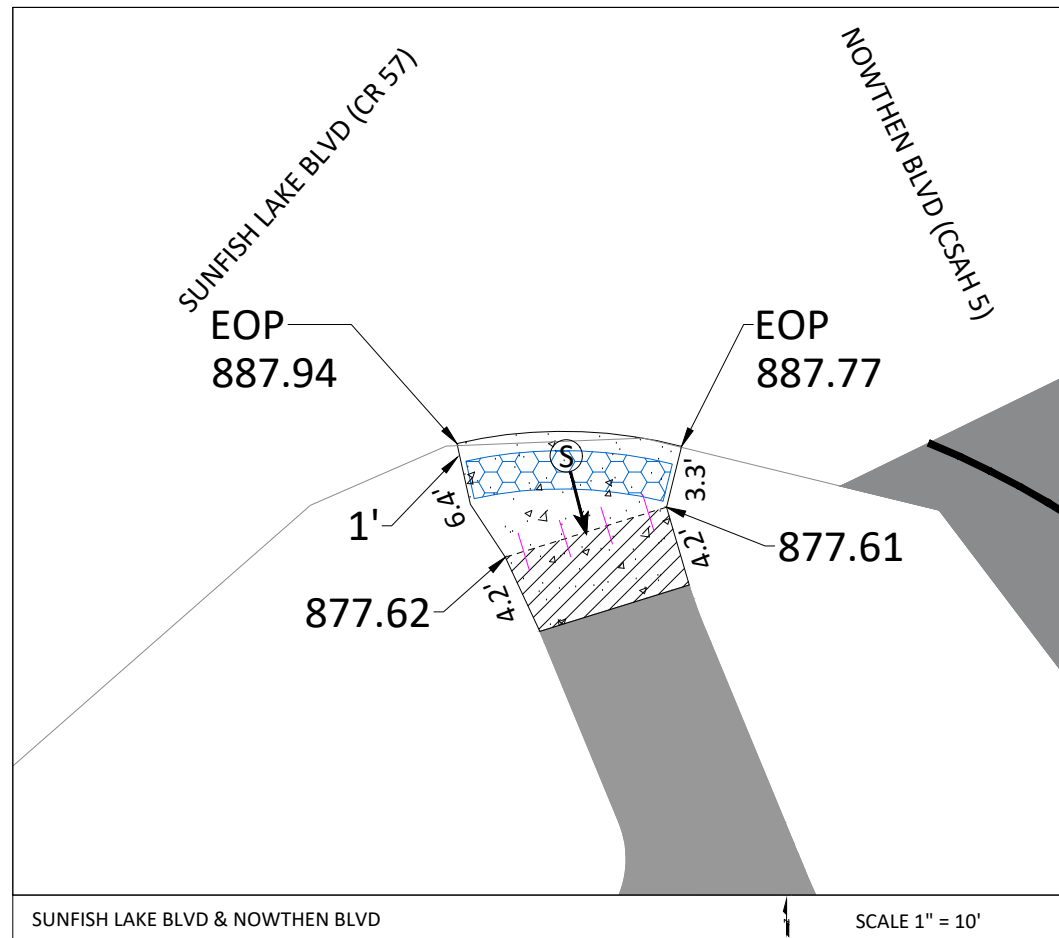
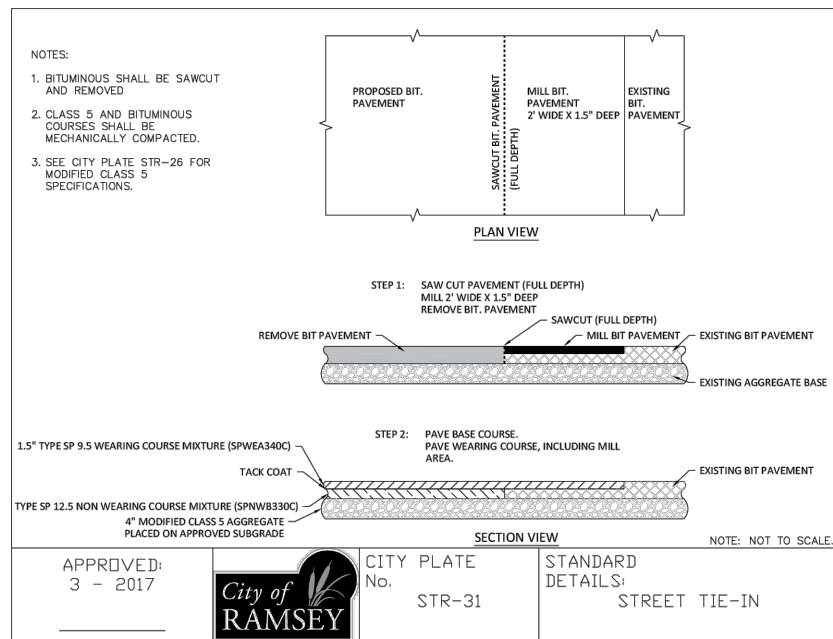
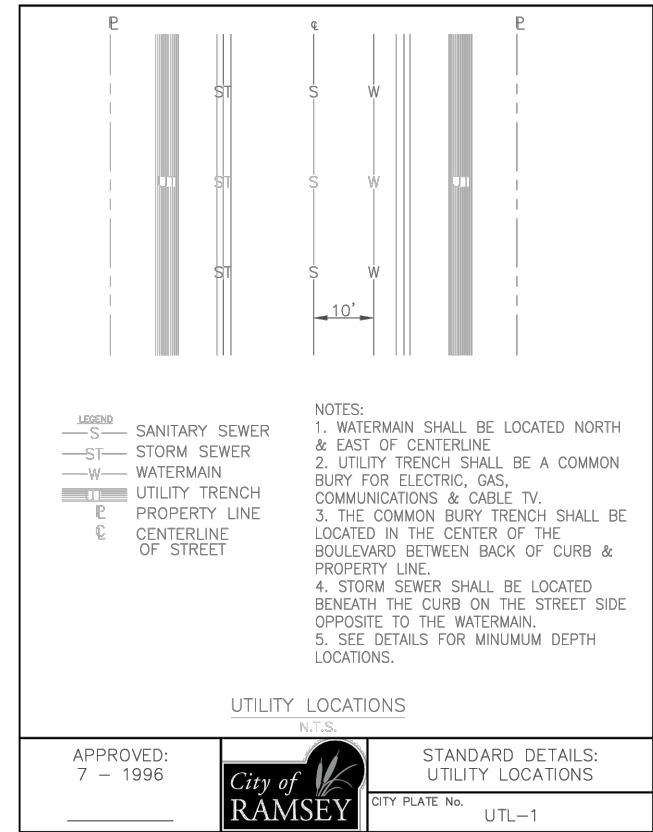
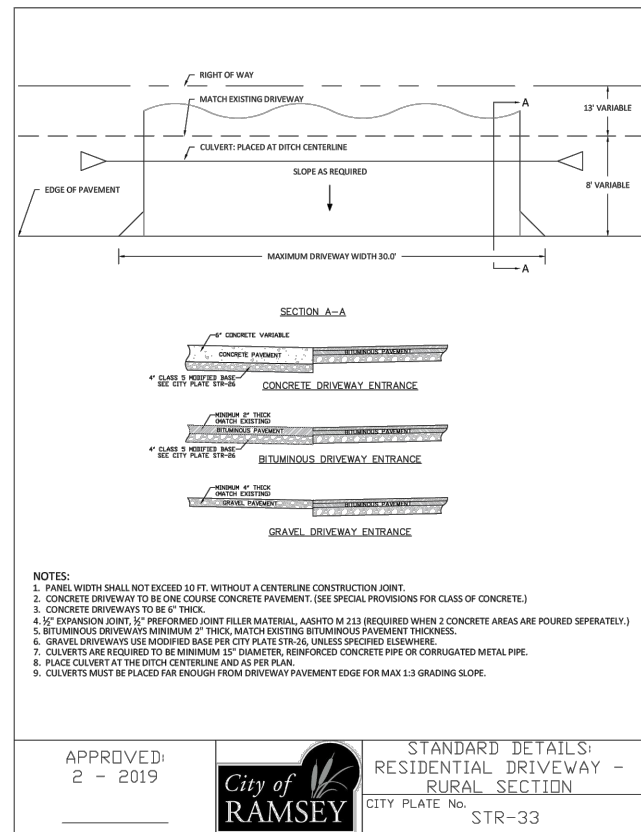

DATE	REVISION

I hereby certify that this plan, specification, or report was prepared by me or under my direct supervision and that I am a duly Licensed Professional Engineer Under the laws of the State of Minnesota

Joe Feriancek
JOE FERIANCEK
Date 1/23/24 Lic. No. 57095

DESIGNED BY: JJF
DRAWN BY: JJF
CHECKED BY: BRW

DATE: 12/15/23
FILE: 24-02

City of RAMSEY

CITY OF RAMSEY
7550 SUNWOOD DRIVE
RAMSEY, MN 55303
(763) 427-1410 FAX (763) 433-9898

DETAILS

HALLS DOVER ACRES STREET RECONSTRUCTIONS
CITY PROJECT NO. 24-02
CITY OF RAMSEY, MINNESOTA

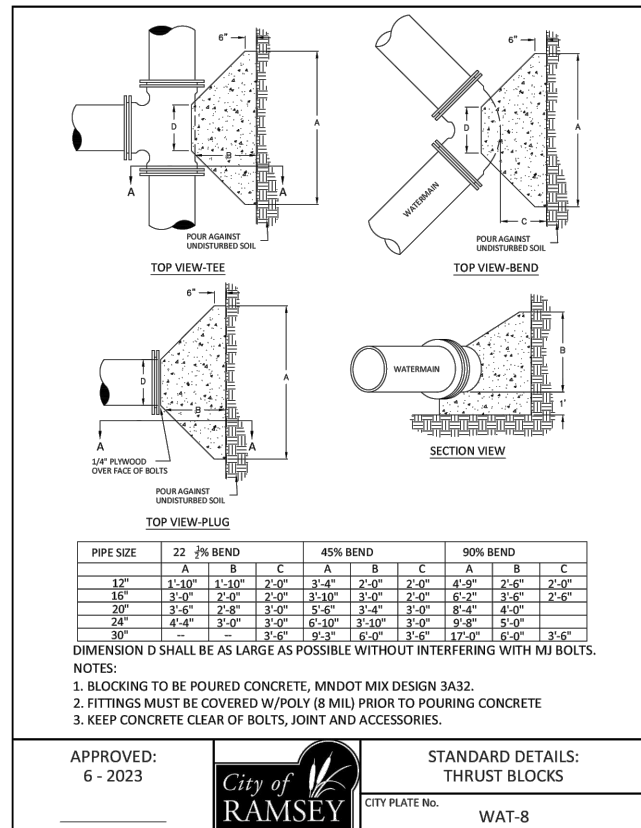
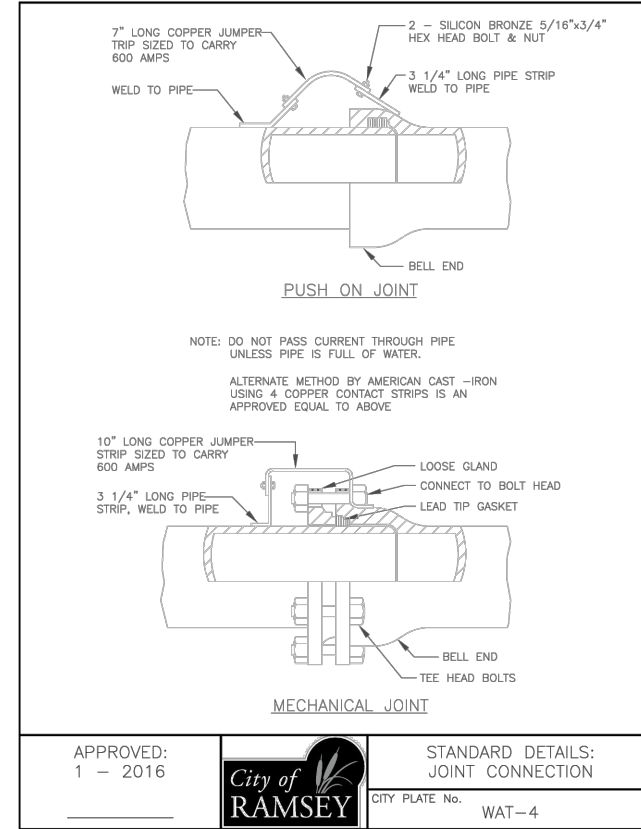
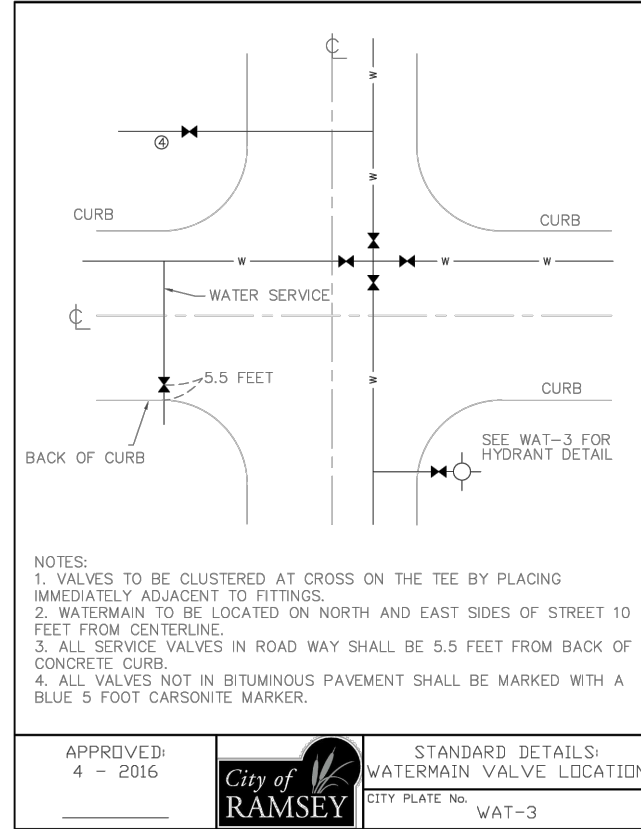
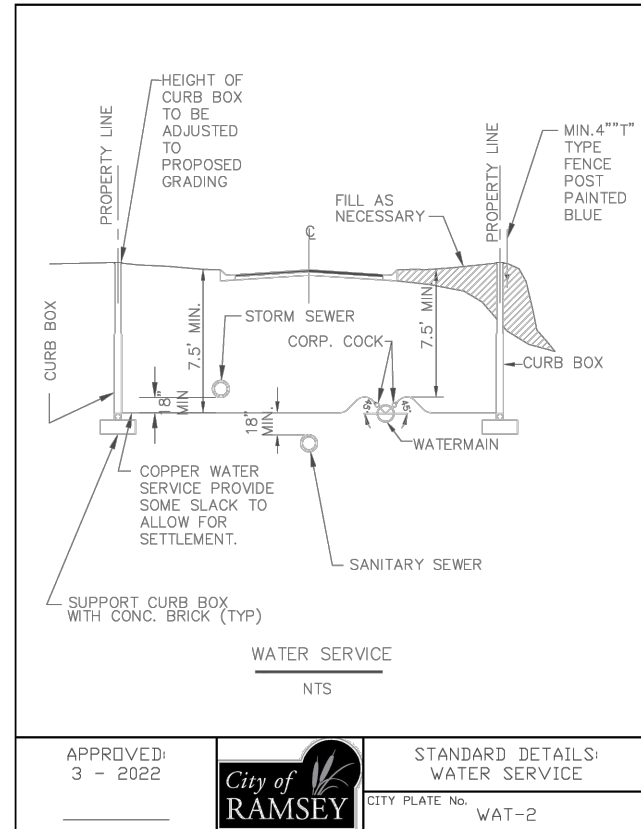
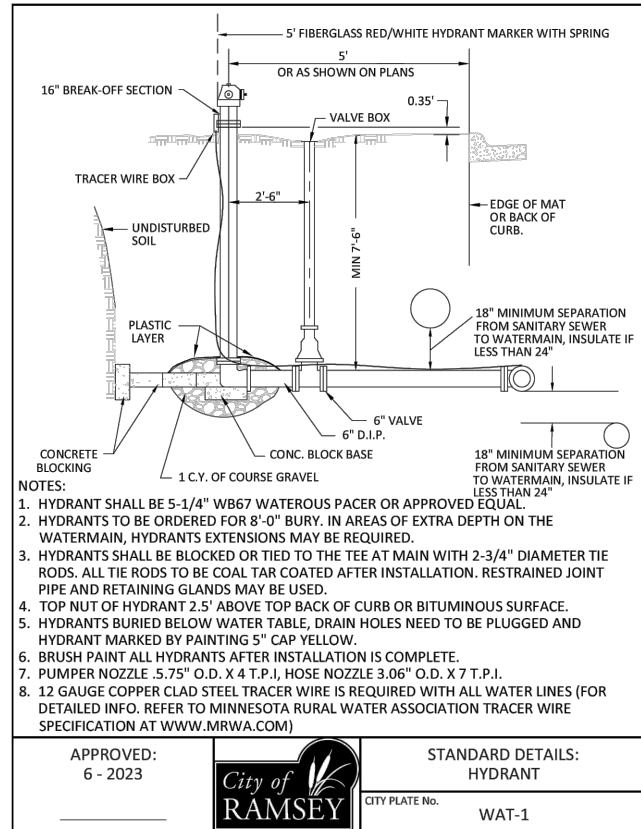

DATE	REVISION

I hereby certify that this plan, specification, or report was prepared by me or under my direct supervision and that I am a duly Licensed Professional Engineer under the laws of the State of Minnesota

Joe Feriancek
JOE FERIANCEK
Date 1/23/24 Lic. No. 57095

DESIGNED BY: JJF
DRAWN BY: JJF
CHECKED BY: BRW

DATE: 12/15/23
FILE: 24-02

CITY OF RAMSEY
7550 SUNWOOD DRIVE
RAMSEY, MN 55303
(763) 427-1410 FAX (763) 433-9898

DETAILS

HALLS DOVER ACRES STREET RECONSTRUCTIONS
CITY PROJECT NO. 24-02
CITY OF RAMSEY, MINNESOTA

Sewer/Water Utility - Trace Wire Specification

Materials

General

All trace wire and trace wire products shall be domestically manufactured in the U.S.A.

All trace wire shall have HDPE insulation intended for direct bury, color coated per APWA standard for the specific utility being marked.

Trace wire

- **Open Trench** - Trace wire shall be #12 AWG Copper Clad Steel, High Strength with minimum 450 lb. break load, with minimum 30 mil HDPE insulation thickness.
- **Directional Drilling/Boring** - Trace wire shall be #12 AWG Copper Clad Steel, Extra High Strength with minimum 1,150 lb. break load, with minimum 30 mil HDPE insulation thickness.
- **Trace wire - Pipe Bursting/Slip Lining** - Trace wire shall be 7 x 7 Stranded Copper Clad Steel, Extreme Strength with 4,700 lb. break load, with minimum 50 mil HDPE insulation thickness.

Connectors

- All mainline trace wires must be interconnected in intersections, at mainline tees and mainline crosses. At tees, the three wires shall be joined using a single 3-way lockable connector. At Crosses, the four wires shall be joined using a 4-way connector. Use of two 3-way connectors with a short jumper wire between them is an acceptable alternative.
- **Direct bury wire connectors** - shall include 3-way lockable connectors and mainline to lateral lug connectors specifically manufactured for use in underground trace wire installation. Connectors shall be dielectric silicon filled to seal out moisture and corrosion, and shall be installed in a manner so as to prevent any uninsulated wire exposure.
- Non locking friction fit, twist on or taped connectors are prohibited.

Termination/Access

- All trace wire termination points must utilize an approved trace wire access box (above ground access box or grade level/in-ground access box as applicable), specifically manufactured for this purpose.
- All grade level/in-ground access boxes shall be appropriately identified with "sewer" or "water" cast into the cap and be color coded.
- A minimum of 2 ft. of excess/slack wire is required in all trace wire access boxes after meeting final elevation.
- All trace wire access boxes must include a manually interruptible conductive/connective link between the terminal(s) for the trace wire connection and the terminal for the grounding anode wire connection.
- Grounding anode wire shall be connected to the identified (or bottom) terminal on all access boxes.

This Standard specification was prepared by Joe Rubbeke (joe.rubbeke@gmail.com), Jeff Dale and Frank Stuenkel, and is a work-in-progress, intended for redistribution, modification and immediate use by any municipality (March 2014). The end user must accept all liabilities and hold harmless the contributors of this information.

Disclaimer: The information provided in this specification gives you options to help you choose the best method for your project. This information is only a guide.

Sewer/Water Utility - Trace Wire Specification

- **Service Laterals on public property** - Trace wire must terminate at an approved grade level/in-ground trace wire access box, located at the edge of the road right-of-way, and out of the roadway.
- **Service Laterals on private property** - Trace wire must terminate at an approved above-ground trace wire access box, affixed to the building exterior directly above where the utility enters the building, at an elevation not greater than 5 vertical feet above finished grade, or terminate at an approved grade level/in-ground trace wire access box, located within 2 linear feet of the building being served by the utility.
- **Hydrants** - Trace wire must terminate at an approved above-ground trace wire access box, properly affixed to the hydrant grade flange. (affixing with tape or plastic ties shall not be acceptable)
- **Long-runs, in excess of 500 linear feet without service laterals or hydrants** - Trace wire access must be provided utilizing an approved grade level/in-ground trace wire access box, located at the edge of the road right-of-way, and out of the roadway. The grade level/in-ground trace wire access box shall be delineated using a minimum 48" polyethylene marker post, color coded per APWA standard for the specific utility being marked.

Grounding

- Trace wire must be properly grounded at all dead ends/stubs
- Grounding of trace wire shall be achieved by use of a drive-in magnesium grounding anode rod with a minimum of 20ft of #12 red HDPE insulated copper clad steel wire connected to anode (minimum 1.5 lb.) specifically manufactured for this purpose, and buried at the same elevation as the utility.
- When grounding the trace wire at dead ends/stubs, the grounding anode shall be installed in a direction 180 degrees opposite of the trace wire, at the maximum possible distance.
- When grounding the trace wire in areas where the trace wire is continuous and neither the mainline trace wire or the grounding anode wire will be terminated at/above grade, install grounding anode directly beneath and in-line with the trace wire. Do not coil excess wire from grounding anode. In this installation method, the grounding anode wire shall be trimmed to an appropriate length before connecting to trace wire with a mainline to lateral lug connector.
- Where the anode wire will be connected to a trace wire access box, a minimum of 2 ft. of excess/slack wire is required after meeting final elevation.

Installation

General

- Trace wire installation shall be performed in such a manner that allows proper access for connection of line tracing equipment, proper locating of wire without loss or deterioration of low frequency (512Hz) signal for distances in excess of 1,000 linear feet, and without distortion of signal caused by multiple wires being installed in close proximity to one another.
- Trace wire systems must be installed as a single continuous wire, except where using approved connectors. No looping or coiling of wire is allowed.

This Standard specification was prepared by Joe Rubbeke (joe.rubbeke@gmail.com), Jeff Dale and Frank Stuenkel, and is a work-in-progress, intended for redistribution, modification and immediate use by any municipality (March 2014). The end user must accept all liabilities and hold harmless the contributors of this information.

Disclaimer: The information provided in this specification gives you options to help you choose the best method for your project. This information is only a guide.

Sewer/Water Utility - Trace Wire Specification

- Any damage occurring during installation of the trace wire must be immediately repaired by removing the damaged wire, and installing a new section of wire with approved connectors. Taping and/or spray coating shall not be allowed.
- Trace wire shall be installed at the bottom half of the pipe and secured (taped/tied) at 5' intervals.
- Trace wire must be properly grounded as specified.
- Trace wire on all service laterals/stubs must terminate at an approved trace wire access box located directly above the utility, at the edge of the road right-of-way, but out of the roadway. (See Trace Wire Termination/Access)
- At all mainline dead-ends, trace wire shall go to ground using an approved connection to a drive-in magnesium grounding anode rod, buried at the same depth as the trace wire. (See Grounding)
- Mainline trace wire shall not be connected to existing conductive pipes. Treat as a mainline dead-end, ground using an approved waterproof connection to a grounding anode buried at the same depth as the trace wire.
- All service lateral trace wires shall be a single wire, connected to the mainline trace wire using a mainline to lateral lug connector, installed without cutting/splicing the mainline trace wire.
- In occurrences where an existing trace wire is encountered on an existing utility that is being extended or tied into, the new trace wire and existing trace wire shall be connected using approved splice connectors, and shall be properly grounded at the splice location as specified.

Sanitary Sewer System

- A mainline trace wire must be installed, with all service lateral trace wires properly connected to the mainline trace wire, to ensure full tracing/locating capabilities from a single connection point.
- Lay mainline trace wire continuously, by-passing around the outside of manholes/structures on the North or East side.
- Trace wire on all sanitary service laterals must terminate at an approved trace wire access box color coded green and located directly above the service lateral at the edge of road right of way.

Water System

- A mainline trace wire must be installed, with all service lateral trace wires properly connected to the mainline trace wire, to ensure full tracing/locating capabilities from a single connection point.
- Lay mainline trace wire continuously, by-passing around the outside of valves and fittings on the North or East side.
- Trace wire on all water service laterals must terminate at an approved trace wire access box color coded blue and located directly above the service lateral at the edge of road right of way.
- Above-ground tracer wire access boxes will be installed on all fire hydrants.
- All conductive and non-conductive service lines shall include tracer wire.

This Standard specification was prepared by Joe Rubbeke (joe.rubbeke@gmail.com), Jeff Dale and Frank Stuenkel, and is a work-in-progress, intended for redistribution, modification and immediate use by any municipality (March 2014). The end user must accept all liabilities and hold harmless the contributors of this information.

Disclaimer: The information provided in this specification gives you options to help you choose the best method for your project. This information is only a guide.

Sewer/Water Utility - Trace Wire Specification

Storm Sewer System

This section shall be included at the discretion of the facility owner.

- If the storm sewer system includes service laterals for connection of private drains and tile lines, it shall be specified the same as a sanitary sewer application.
- Lay mainline trace wire continuously, by-passing around the outside of manholes/structure on the North or East side.

Prohibited Products and Methods

The following products and methods shall not be allowed or acceptable

- Uninsulated trace wire
- Trace wire insulations other than HDPE
- Trace wires not domestically manufactured
- Non locking, friction fit, twist on or taped connectors
- Brass or copper ground rods
- Wire connections utilizing taping or spray-on waterproofing
- Looped wire or continuous wire installations, that has multiple wires laid side-by-side or in close proximity to one another
- Trace wire wrapped around the corresponding utility
- Brass fittings with trace wire connection lugs
- Wire terminations within the roadway, i.e. in valve boxes, cleanouts, manholes, etc.
- Connecting trace wire to existing conductive utilities

Testing

All new trace wire installations shall be located using typical low frequency (512Hz) line tracing equipment, witnessed by the contractor, engineer and facility owner as applicable, prior to acceptance of ownership.

This verification shall be performed upon completion of rough grading and again prior to final acceptance of the project.

Continuity testing in lieu of actual line tracing shall not be accepted.

This Standard specification was prepared by Joe Rubbeke (joe.rubbeke@gmail.com), Jeff Dale and Frank Stuenkel, and is a work-in-progress, intended for redistribution, modification and immediate use by any municipality (March 2014). The end user must accept all liabilities and hold harmless the contributors of this information.

Disclaimer: The information provided in this specification gives you options to help you choose the best method for your project. This information is only a guide.

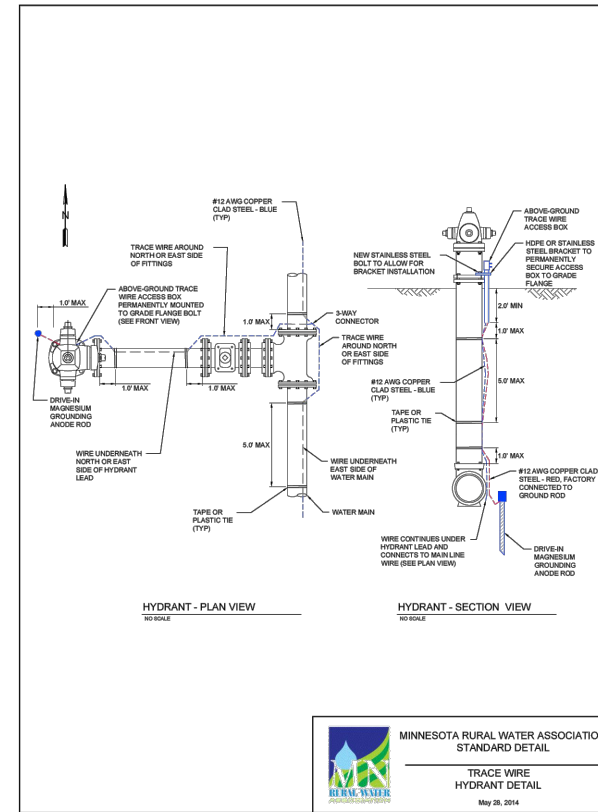
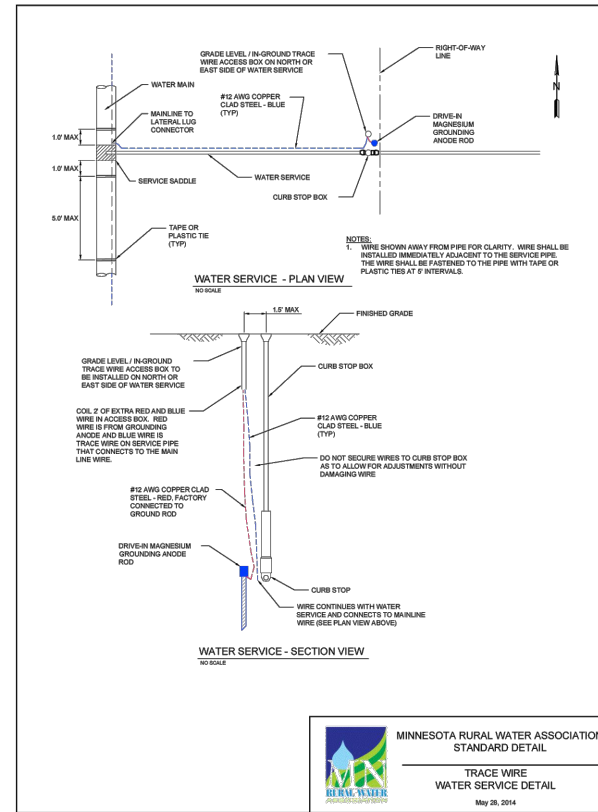
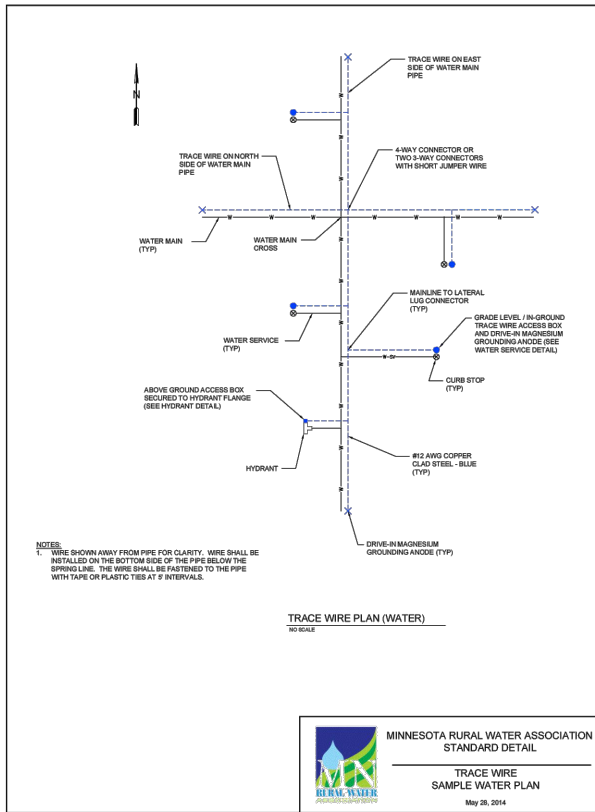

DATE	REVISION

I hereby certify that this plan, specification, or report was prepared by me or under my direct supervision and that I am a duly Licensed Professional Engineer Under the laws of the State of Minnesota

Joe Feriancek
JOE FERIANCEK
Date: 4/23/24 Lic. No. 57095

DESIGNED BY:	JJF
DRAWN BY:	JJF
CHECKED BY:	BRW

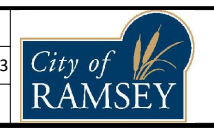

CITY OF RAMSEY
7550 SUNWOOD DRIVE
RAMSEY, MN 55303
(763) 427-1410 FAX (763) 433-9898

DETAILS

HALLS DOVER ACRES STREET RECONSTRUCTIONS
CITY PROJECT NO. 24-02
CITY OF RAMSEY, MINNESOTA

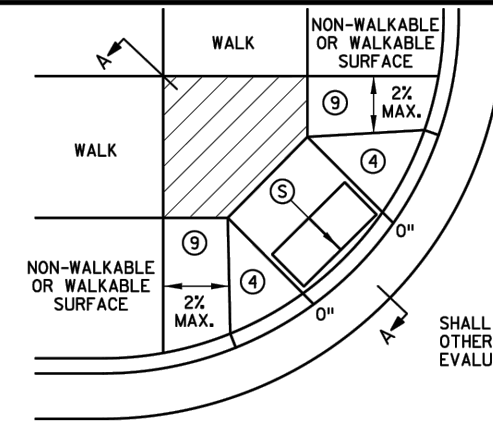
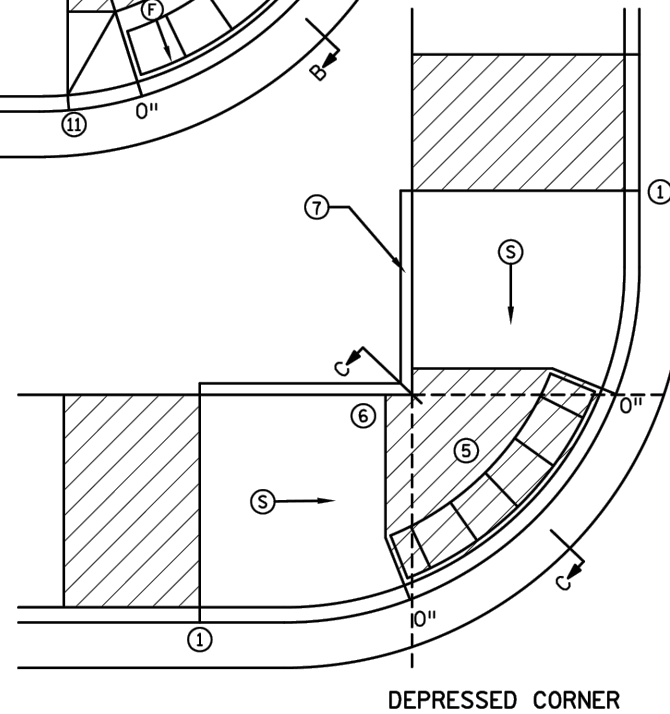
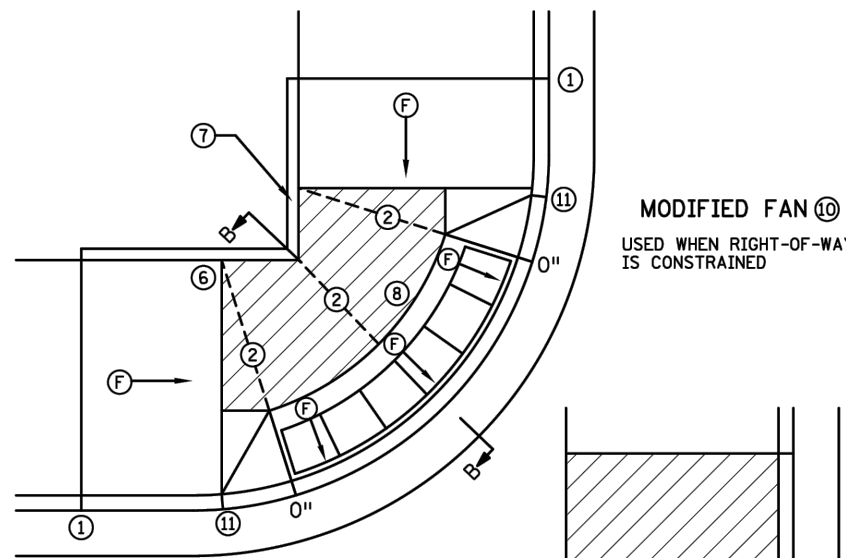
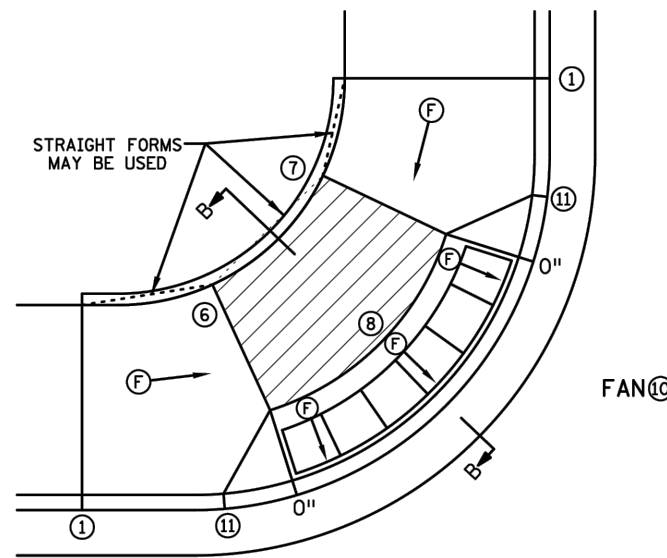
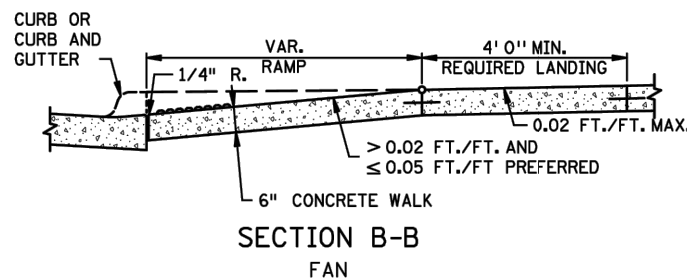
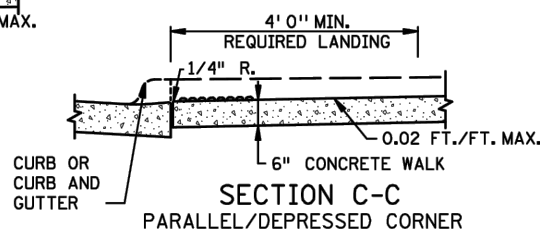
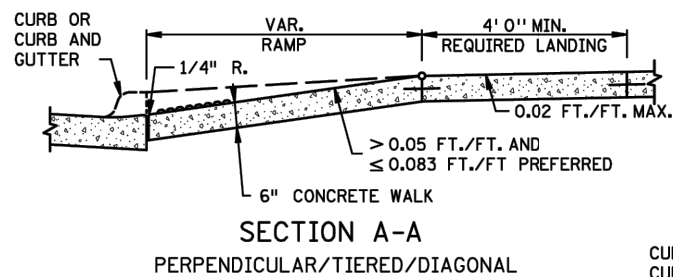
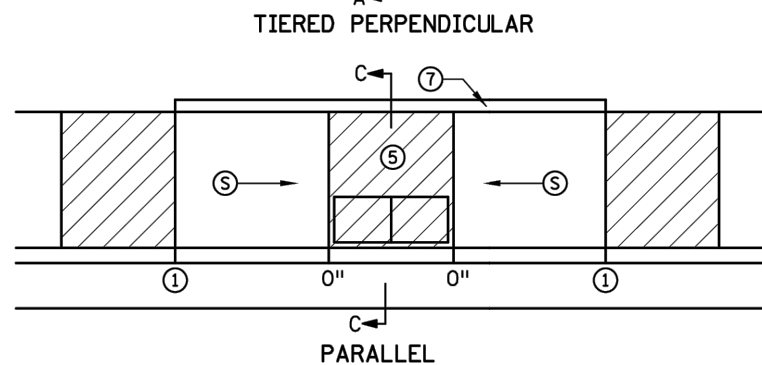
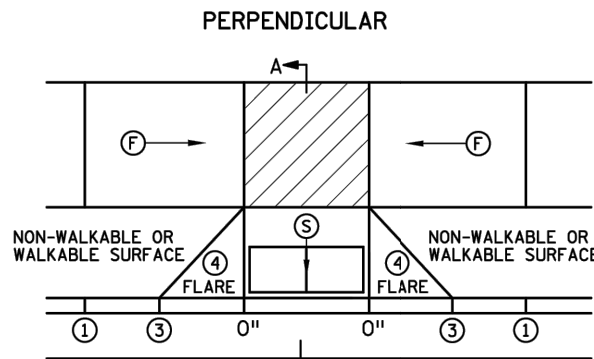
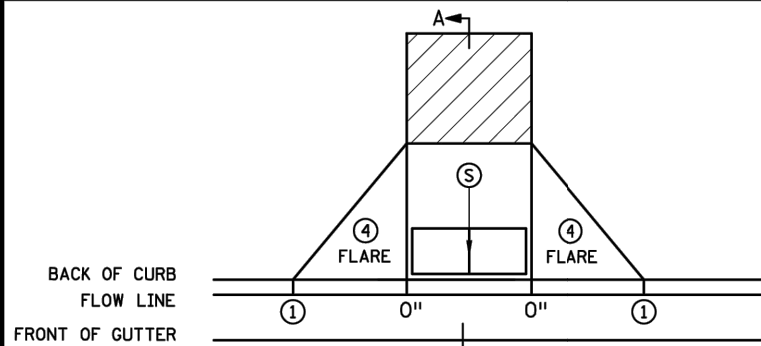

NOTES:

- LANDINGS SHALL BE LOCATED ANYWHERE THE PEDESTRIAN ACCESS ROUTE (PAR) CHANGES DIRECTION, AT THE TOP OF RAMPS THAT HAVE RUNNING SLOPES GREATER THAN 5.0%, AND IF THE APPROACHING WALK IS INVERSE GRADE GREATER THAN 2%.
 - INITIAL CURB RAMP LANDINGS SHALL BE CONSTRUCTED WITHIN 15' FROM THE BACK OF CURB, WITH 6' FROM THE BACK OF CURB BEING THE PREFERRED DISTANCE, ONLY APPLICABLE WHEN THE INITIAL RAMP RUNNING SLOPE IS OVER 5.0%.
 - SECONDARY CURB RAMP LANDINGS ARE REQUIRED FOR EVERY 30" OF VERTICAL RISE WHEN THE LONGITUDINAL RUNNING SLOPE IS GREATER THAN 5.0%.
 - CONTRACTION JOINTS SHALL BE CONSTRUCTED ALONG ALL GRADE BREAKS WITHIN THE PAR. 1/4" DEEP VISUAL JOINTS SHALL BE USED AT THE TOPS OF CONCRETE FLARES ADJACENT TO WALKABLE SURFACES.
 - ALL GRADE BREAKS WITHIN THE PAR SHALL BE PERPENDICULAR TO THE PATH OF TRAVEL, THUS BOTH SIDES OF A SLOPED WALKING SURFACE MUST BE EQUAL LENGTH, (EXCEPT AS STATED IN 6) BELOW.
 - TO ENSURE RAMPS AND LANDINGS ARE PROPERLY CONSTRUCTED, ALL INITIAL LANDINGS AT A TOP OF A RAMPED SURFACE (RUNNING SLOPE GREATER THAN 2%) SHALL BE FORMED AND PLACED SEPARATELY IN AN INDEPENDENT CONCRETE POUR. FOLLOW SIDEWALK REINFORCEMENT DETAILS ON SHEET 6 OF 6 FOR ALL SEPARATELY POURED INITIAL LANDINGS.
 - WHEN SIDEWALK IS AT BACK OF CURB, TOP OF CURB SHALL MATCH PROPOSED ADJACENT WALK GRADE. MAINTAIN POSITIVE BOULEVARD DRAINAGE TO TOP OF CURB.
 - ALL RAMP TYPES SHOULD HAVE A MINIMUM 3' LONG RAMP LENGTH.
 - 4' MINIMUM WIDTH OF DETECTABLE WARNING IS REQUIRED FOR ALL RAMPS. DETECTABLE WARNINGS SHALL CONTINUOUSLY EXTEND FOR A MIN. OF 24" IN THE PATH OF TRAVEL. DETECTABLE WARNING TO COVER THE ENTIRE PAR WIDTH OF SHARED-USE PATHS AND THE ENTIRE PAR WIDTH OF THE WALK WITH THE EXCEPTION OF 3" MAXIMUM ON EACH OUTSIDE EDGE WHICH ENSURES THE DETECTABLE WARNINGS ARE ENCASED IN CONCRETE WHEN ADJACENT TO TURF. WHEN ADJACENT TO CONCRETE FLARES 0" - 3" OFFSET IS ALLOWED.
 - WHEN DESIGNING OR ORDERING RECTANGULAR DETECTABLE WARNING SURFACES SHOULD BE 6" LESS THAN THE INCOMING PAR. ARC LENGTH OF THE RADIAL DETECTABLE WARNINGS SHOULD NOT BE GREATER THAN 20 FEET.
 - RECTANGULAR DETECTABLE WARNINGS SHALL BE SETBACK 3" FROM THE BACK OF CURB. RADIAL DETECTABLE WARNINGS SHALL BE SETBACK 3" MINIMUM TO 6" MAXIMUM FROM THE BACK OF CURB.
- 1 MATCH FULL HEIGHT CURB.
 - 2 4' MINIMUM DEPTH LANDING REQUIRED ACROSS TOP OF RAMP.
 - 3 3" HIGH CURB WHEN USING A 3' LONG RAMP, 4" HIGH CURB WHEN USING A 4' LONG RAMP.
 - 4 SEE SHEET 4 OF 6, TYPICAL SIDE TREATMENT OPTIONS, FOR DETAILS ON FLARES AND RETURNED CURBS.
 - 5 DETECTABLE WARNINGS MAY BE PART OF THE 4' X 4' MIN. LANDING AREA IF IT IS NOT FEASIBLE TO CONSTRUCT THE LANDING OUTSIDE OF THE DETECTABLE WARNING AREA.
 - 6 THE GRADE BREAK SHALL BE PERPENDICULAR TO THE BACK OF WALK. THIS WILL ENSURE THAT THE GRADE BREAK IS PERPENDICULAR TO THE DIRECTION OF TRAVEL. (TYPICAL FOR ALL)
 - 7 WHEN ADJACENT TO GRASS, GRADING SHALL ALWAYS BE USED WHEN FEASIBLE. V CURB, IF USED, SHALL BE PLACED OUTSIDE THE SIDEWALK LIMITS WHEN RIGHT OF WAY ALLOWS. WHEN ADJACENT TO PARKING LOTS, CONCRETE OR BITUMINOUS TAPERS LESS THAN 5% RUNNING SLOPE SHOULD BE USED OVER V CURB TO REDUCE TRIPPING HAZARDS AND FACILITATE SNOW & ICE REMOVAL.
 - 8 A 7' MIN TOP RADIUS GRADE BREAK IS REQUIRED TO BE CONSTRUCTIBLE.
 - 9 PAVE FULL WALK WIDTH.
 - 10 "S" SLOPES ON FANS SHALL ONLY BE USED WHEN ALL OTHER FEASIBLE OPTIONS HAVE BEEN EVALUATED AND DEEMED IMPRACTICAL.
 - 11 INTERMEDIATE CURB HEIGHTS TAPER SHALL RISE AT 8-10% TO A MINIMUM 3" CURB HEIGHT. REDUCE INTERMEDIATE CURB HEIGHT TO 2+ INCHES IF NECESSARY TO MATCH ADJACENT BOULEVARD OR SIDEWALK GRADES.

LEGEND	
(S)	INDICATES PEDESTRIAN RAMP - SLOPE SHALL BE BETWEEN 5.0% MINIMUM AND 8.3% MAXIMUM IN THE DIRECTION SHOWN AND THE CROSS SLOPE SHALL NOT EXCEED 2.0%.
(F)	INDICATES PEDESTRIAN RAMP - SLOPE SHALL BE GREATER THAN 2.0% AND LESS THAN 5.0% IN THE DIRECTION SHOWN AND CROSS SLOPE SHALL NOT EXCEED 2.0%.
[Hatched Box]	LANDING AREA - 4' X 4' MIN. (5' X 5' MIN. PREFERRED) DIMENSIONS AND MAX 2.0% SLOPE IN ALL DIRECTIONS. LANDING SHALL BE FULL WIDTH OF INCOMING PARS.
X"	CURB HEIGHT

REVISION:
 APPROVED: 11-04-2021
 Jeff J. Perkins
 OPERATIONS DIVISION

MINNESOTA DEPARTMENT OF TRANSPORTATION
 STANDARD PLAN 5-297.250 1 OF 6
 APPROVED: 11-04-2021
 THOMAS TYRBICKI
 STATE DESIGN ENGINEER

PEDESTRIAN CURB RAMP DETAILS
 STATE PROJ. NO. (TH) SHEET NO. OF SHEETS

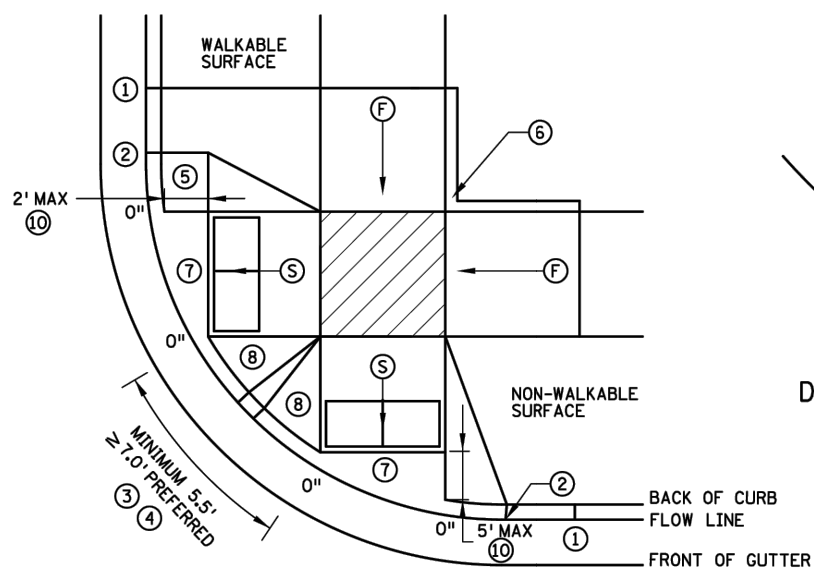

COMBINED DIRECTIONAL

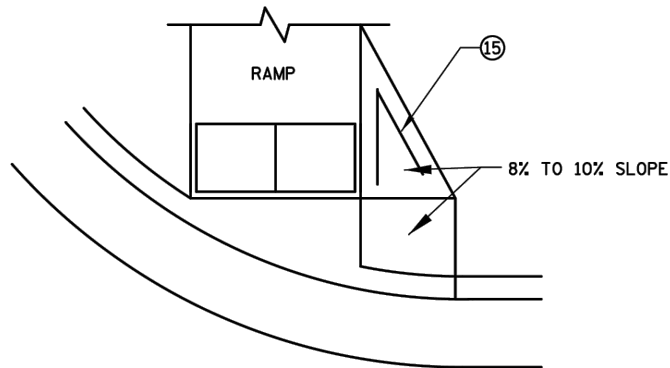

DIRECTIONAL RAMP WALKABLE FLARE

IF NON-CONCRETE BLVD. IS CONSTRUCTED AND IS LESS THAN 2' IN WIDTH AT TOP OF CURB TRANSITION, PAVE CONCRETE RAMP WIDTH TO ADJACENT BACK OF CURB.

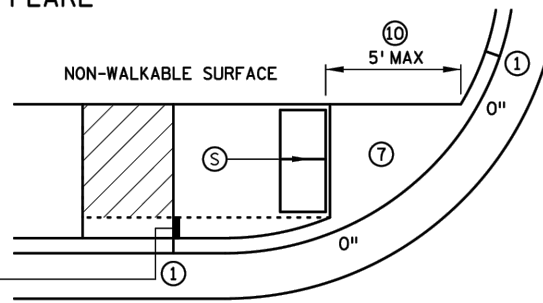

STANDARD ONE-WAY DIRECTIONAL ⑨

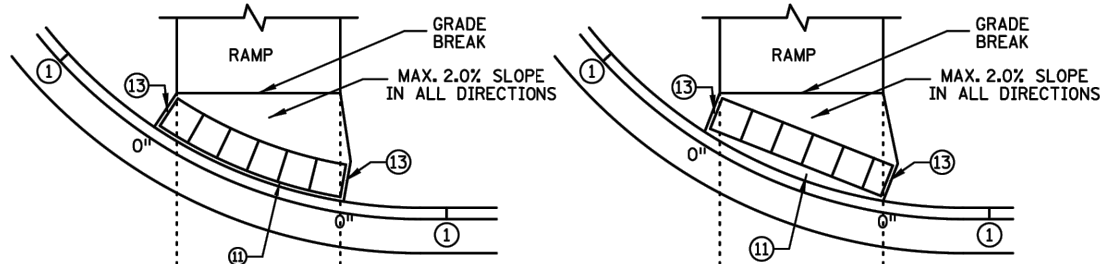

DETECTABLE WARNING PLACEMENT WHEN SETBACK CRITERIA IS EXCEEDED ⑫

ONE-WAY DIRECTIONAL WITH DETECTABLE WARNING AT BACK OF CURB

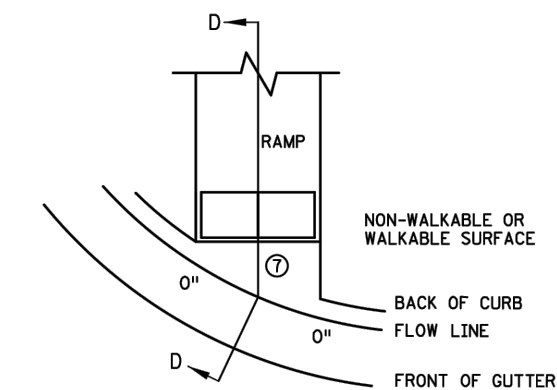

CURB FOR DIRECTIONAL RAMPS ⑭

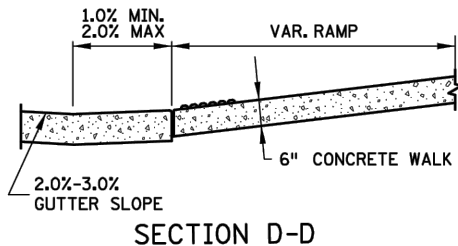

SECTION D-D

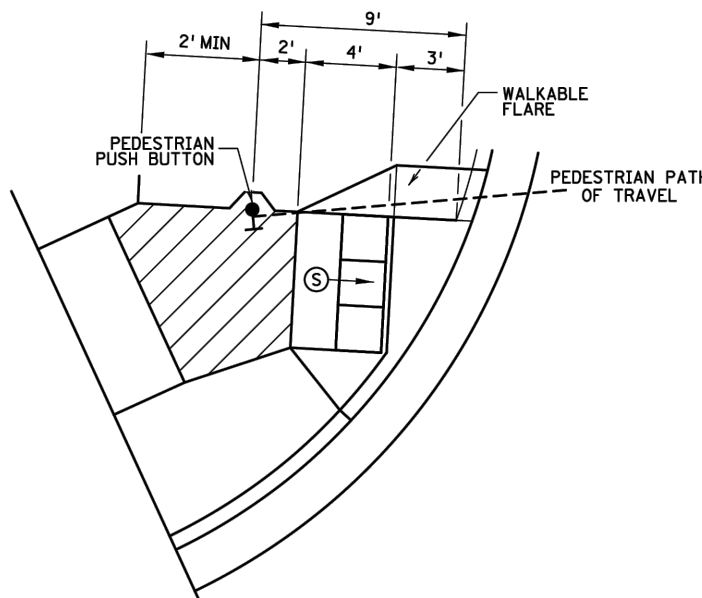

SEMI-DIRECTIONAL RAMP ③④⑨

3' DOME SETBACK, 4' LONG RAMP AND PUSH BUTTON 9' FROM THE BACK OF CURB PRIMARILY USED FOR APS APPLICATIONS WHERE THE PAR DOES NOT CONTINUE PAST THE PUSH BUTTON (DEAD-END SIDEWALK)

NOTES:

LANDINGS SHALL BE LOCATED ANYWHERE THE PEDESTRIAN ACCESS ROUTE (PAR) CHANGES DIRECTION, AT THE TOP OF RAMPS THAT HAVE RUNNING SLOPES GREATER THAN 5.0%, AND IF THE APPROACHING WALK IS INVERSE GRADE.

INITIAL CURB RAMP LANDINGS SHALL BE CONSTRUCTED WITHIN 15' FROM THE BACK OF CURB, WITH 6' FROM THE BACK OF CURB BEING THE PREFERRED DISTANCE, ONLY APPLICABLE WHEN THE INITIAL RAMP RUNNING SLOPE IS OVER 5.0%.

SECONDARY CURB RAMP LANDINGS ARE REQUIRED FOR EVERY 30" OF VERTICAL RISE WHEN THE LONGITUDINAL SLOPE IS GREATER THAN 5.0%.

CONTRACTION JOINTS SHALL BE CONSTRUCTED ALONG ALL GRADE BREAKS WITHIN THE PAR. 1/4" DEEP VISUAL JOINTS SHALL BE USED AT THE TOP GRADE BREAK OF CONCRETE FLARES ADJACENT TO WALKABLE SURFACES.

ALL GRADE BREAKS WITHIN THE PAR SHALL BE PERPENDICULAR TO THE PATH OF TRAVEL. THUS BOTH SIDES OF A SLOPED WALKING SURFACE MUST BE EQUAL LENGTH.

TO ENSURE INITIAL RAMPS AND INITIAL LANDINGS ARE PROPERLY CONSTRUCTED, LANDINGS SHALL BE CAST SEPARATELY, FOLLOW SIDEWALK REINFORCEMENT DETAILS ON SHEET 6 AND THE ADA SPECIAL PROVISION (PROSECUTION OF WORK).

TOP OF CURB SHALL MATCH PROPOSED ADJACENT WALK GRADE.

WHEN THE BOULEVARD IS 4' WIDE OR LESS, THE TOP OF CURB TAPER SHALL MATCH THE RAMP SLOPES TO REDUCE NEGATIVE BOULEVARD SLOPES FROM THE TOP BACK OF CURB TO THE PAR.

ALL RAMP TYPES SHOULD HAVE A MINIMUM 3' LONG RAMP LENGTH.

4' MINIMUM WIDTH OF DETECTABLE WARNING IS REQUIRED FOR ALL RAMPS. DETECTABLE WARNINGS SHALL CONTINUOUSLY EXTEND FOR A MIN. OF 24" IN THE PATH OF TRAVEL. DETECTABLE WARNING TO COVER THE ENTIRE PAR WIDTH OF SHARED-USE PATHS AND THE ENTIRE PAR WIDTH OF THE WALK WITH THE EXCEPTION OF 3" MAXIMUM ON EACH OUTSIDE EDGE WHICH ENSURES THE DETECTABLE WARNINGS ARE ENCASED IN CONCRETE WHEN ADJACENT TO TURF. WHEN ADJACENT TO CONCRETE FLARES 0" - 3" OFFSET IS ALLOWED.

WHEN DESIGNING OR ORDERING RECTANGULAR DETECTABLE WARNING SURFACES SHOULD BE 6" LESS THAN THE INCOMING PAR. ARC LENGTH OF THE RADIAL DETECTABLE WARNINGS SHOULD NOT BE GREATER THAN 20 FEET.

RADIAL DETECTABLE WARNINGS SHALL BE SETBACK 3" MINIMUM TO 6" MAXIMUM FROM THE BACK OF CURB. SEE NOTES ⑩ & ⑪ FOR INFORMATION REGARDING RECTANGULAR DETECTABLE WARNING PLACEMENT.

① MATCH FULL CURB HEIGHT.

② 3" HIGH CURB WHEN USING A 3' LONG RAMP
4" HIGH CURB WHEN USING A 4' LONG RAMP.

③ 3" MINIMUM CURB HEIGHT (5.5' MIN. DISTANCE REQUIRED BETWEEN DOMES)
4" PREFERRED (7' MIN. DISTANCE REQUIRED BETWEEN DOMES).

④ THE "BUMP" IN BETWEEN THE RAMPS SHOULD NOT BE IN THE PATH OF TRAVEL FOR COMBINED DIRECTIONAL RAMPS. IF THIS OCCURS MODIFY THE RAMP LOCATION OR SWITCH RAMP TO A FAN/DEPRESSED CORNER.

⑤ WHEN USING CONCRETE PAVED FLARES ON THE OUTSIDE OF DIRECTIONAL RAMPS, AND ADJACENT TO A WALKABLE SURFACE, DIRECTIONAL RAMP FLARES SHALL BE USED. SEE THE DETAIL ON THIS SHEET.

⑥ GRADING SHALL ALWAYS BE USED WHEN FEASIBLE. V CURB, IF USED, SHALL BE PLACED OUTSIDE THE SIDEWALK LIMITS WHEN RIGHT OF WAY ALLOWS. WHEN ADJACENT TO PARKING LOTS, CONCRETE OR BITUMINOUS TAPERS SHOULD BE USED OVER V CURB TO REDUCE TRIPPING HAZARDS AND FACILITATE SNOW & ICE REMOVAL.

⑦ MAX. 2.0% SLOPE IN ALL DIRECTIONS IN FRONT OF GRADE BREAK AND DRAIN TO FLOW LINE. SHALL BE CONSTRUCTED INTEGRAL WITH CURB AND GUTTER.

⑧ 8% TO 10% WALKABLE FLARE.

⑨ PLACE DOMES AT THE BACK OF CURB WHEN ALLOWABLE SETBACK CRITERIA IS EXCEEDED.

⑩ FRONT EDGE OF DETECTABLE WARNING SHALL BE SET BACK 2' MAXIMUM WHEN ADJACENT TO WALKABLE SURFACE, AND 5' MAXIMUM WHEN ADJACENT TO NON-WALKABLE SURFACE WITH ONE CORNER SET 3" FROM BACK OF CURB. A WALKABLE SURFACE IS DEFINED AS A PAVED SURFACE ADJACENT TO A CURB RAMP WITHOUT RAISED OBSTACLES THAT COULD MISTAKENLY BE TRAVERSED BY A USER WHO IS VISUALLY IMPAIRED.

⑪ RECTANGULAR DETECTABLE WARNINGS MAY BE SETBACK UP TO 9" FROM THE BACK OF CURB WITH CORNERS SET 3" FROM BACK OF CURB. IF 9" SETBACK IS EXCEEDED USE RADIAL DETECTABLE WARNINGS.

⑫ FOR DIRECTIONAL RAMPS WITH THE DETECTABLE WARNINGS PLACED AT THE BACK OF CURB, THE DETECTABLE WARNINGS SHALL COVER THE ENTIRE WIDTH OF THE WALK/PATH. THIS ENSURES A DETECTABLE EDGE AND HELPS ELIMINATE THE CURB TAPER OBSTRUCTING THE PATH OF PEDESTRIAN TRAVEL.

⑬ THE CONCRETE WALK SHALL BE FORMED AND CONSTRUCTED PERPENDICULAR TO THE BACK OF CURB. MAINTAIN 3" BETWEEN EDGE OF DOMES AND EDGE OF CONCRETE.

⑭ TO BE USED FOR ALL DIRECTIONAL RAMPS, EXCEPT WHERE DOMES ARE PLACED ALONG THE BACK OF CURB.

⑮ PLACE 2 NO. 4 BARS 4 INCHES FROM SIDE OF FORMS WITH A MINIMUM 2 INCHES OF CONCRETE COVER ALONG EACH SIDE OF FLARE (INCIDENTAL).

LEGEND

THESE LONGITUDINAL SLOPE RANGES SHALL BE THE STARTING POINT. IF SITE CONDITIONS WARRANT, LONGITUDINAL SLOPES UP TO 8.3% OR FLATTER ARE ALLOWED.

Ⓢ INDICATES PEDESTRIAN RAMP - SLOPE SHALL BE BETWEEN 5.0% MINIMUM AND 8.3% MAXIMUM IN THE DIRECTION SHOWN AND THE CROSS SLOPE SHALL NOT EXCEED 2.0%.

Ⓣ INDICATES PEDESTRIAN RAMP - SLOPE SHALL BE GREATER THAN 2.0% AND LESS THAN 5.0% IN THE DIRECTION SHOWN AND CROSS SLOPE SHALL NOT EXCEED 2.0%.

▨ LANDING AREA - 4' X 4' MIN. (5' X 5' MIN. PREFERRED) DIMENSIONS AND MAX 2.0% SLOPE IN ALL DIRECTIONS. LANDING SHALL BE FULL WIDTH OF INCOMING PAR.

X" CURB HEIGHT

REVISION:
APPROVED: 11-04-2021
<i>Jeff J. Perkins</i> JEFFREY PERKINS OPERATIONS DIVISION



STANDARD PLAN 5-297.250	2 OF 6
APPROVED: 11-04-2021	REVISOR:
STATE PROJ. NO.	(T.H.) SHEET NO. OF SHEETS

PEDESTRIAN CURB RAMP DETAILS	
STATE PROJ. NO.	(T.H.) SHEET NO. OF SHEETS

DATE	REVISION

DESIGNED BY: JJF	DATE: 12/15/23
DRAWN BY: JJF	FILE: 24-02
CHECKED BY: BRW	

CITY OF RAMSEY
7550 SUNWOOD DRIVE
RAMSEY, MN 55303
(763) 427-1410 FAX (763) 433-9898

MNDOT PEDESTRIAN RAMP DETAILS

HALLS DOVER ACRES STREET RECONSTRUCTIONS
CITY PROJECT NO. 24-02
CITY OF RAMSEY, MINNESOTA

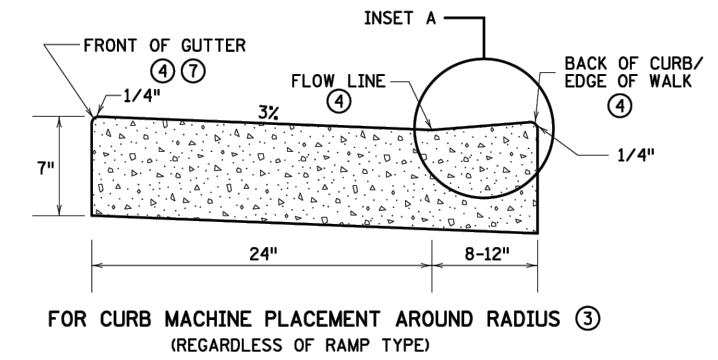
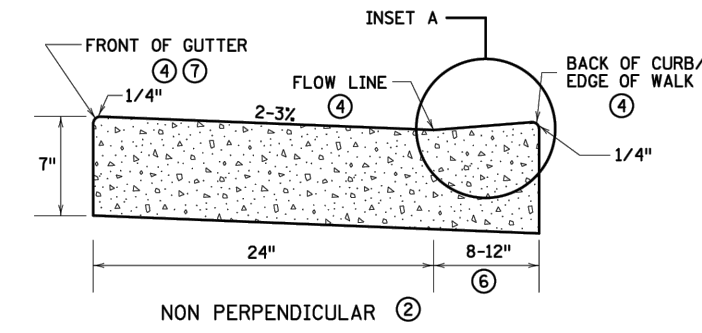
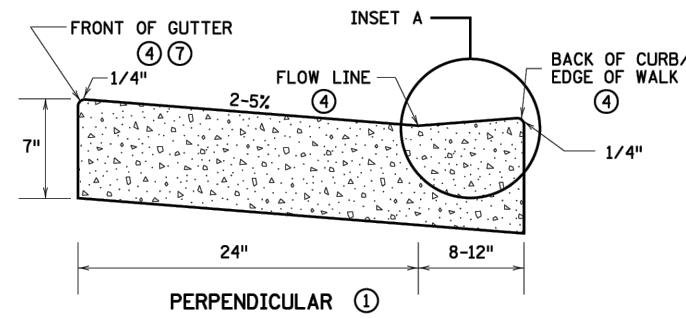
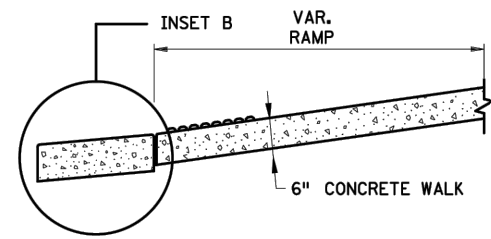

PEDESTRIAN ACCESS ROUTE CURB & GUTTER DETAIL

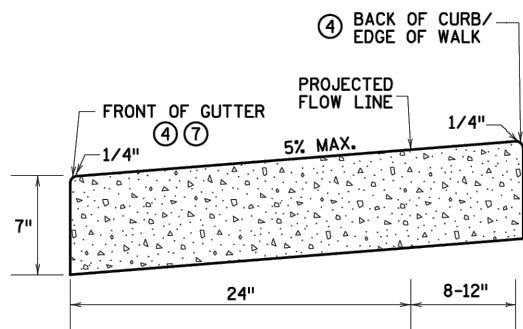

INSET B
OUTFLOW GUTTER ⑧

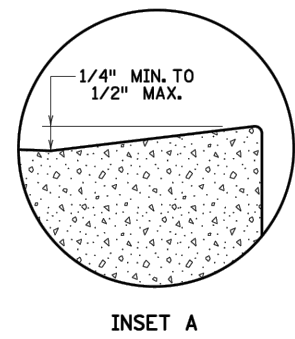

INSET A

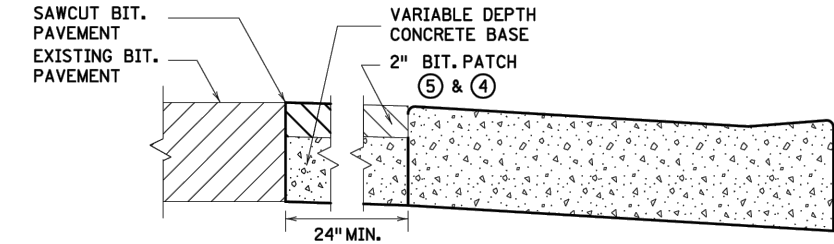
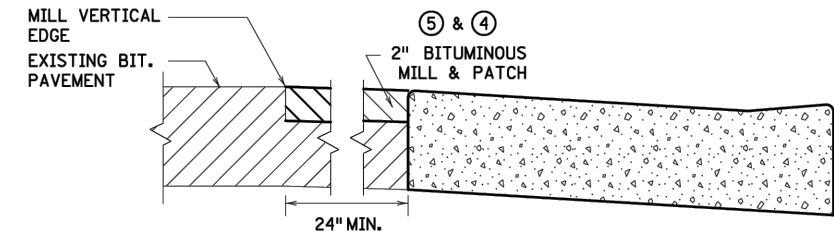

ONLY ALLOWED PER ENGINEER'S APPROVAL

PAVEMENT TREATMENT OPTIONS IN FRONT OF CURB & GUTTER
FOR USE ON CURB RAMP RETROFITS

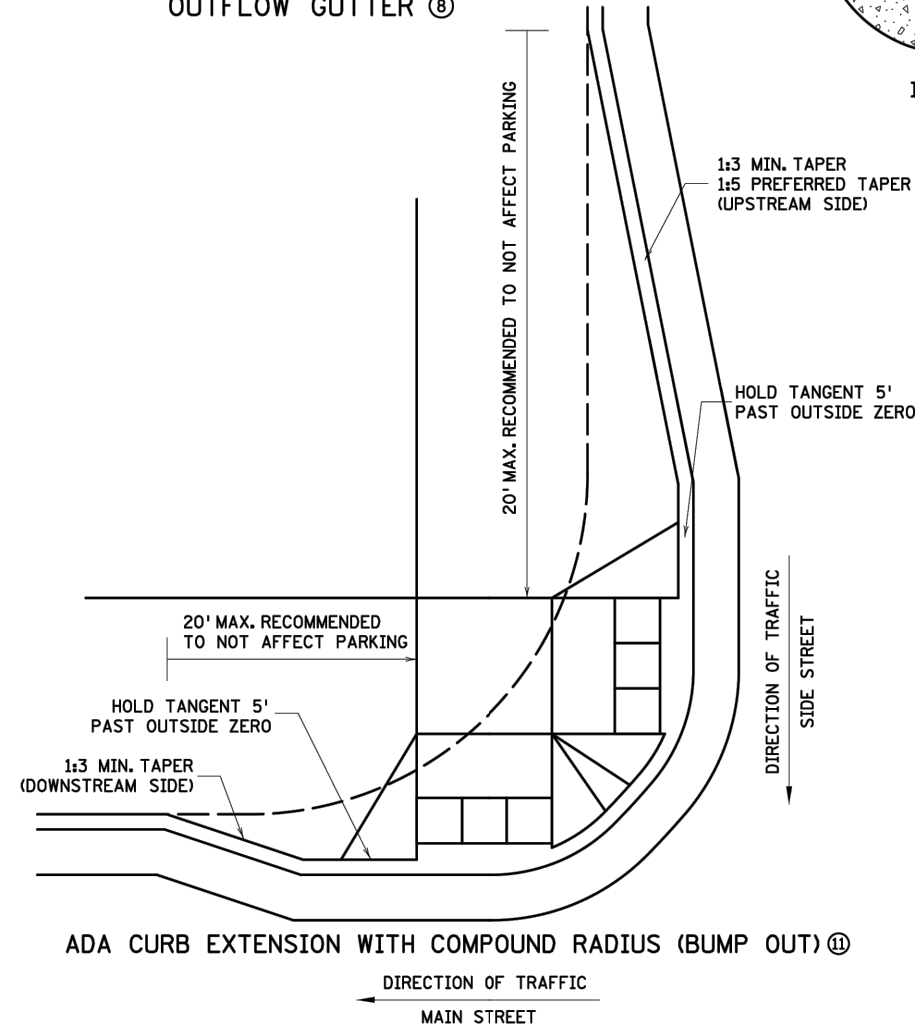

ADA CURB EXTENSION WITH COMPOUND RADIUS (BUMP OUT) ⑩

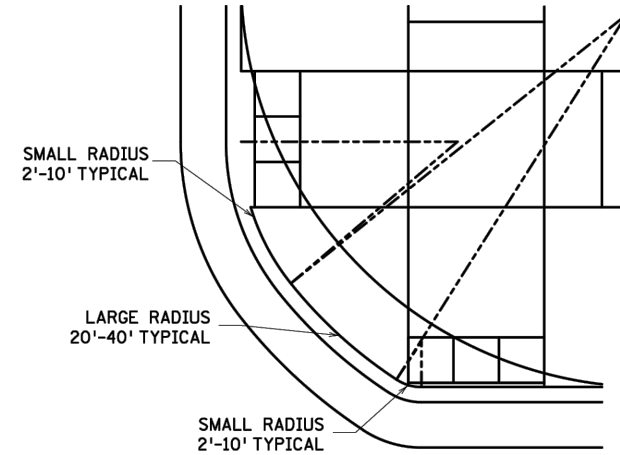

COMBINED DIRECTIONAL ⑩
(COMPOUND RADIUS)

- NOTES:**
- POSITIVE FLOW LINE DRAINAGE SHALL BE MAINTAINED THROUGH THE PEDESTRIAN ACCESS ROUTE (PAR) AT A 2% MAXIMUM. NO PONDING SHALL BE PRESENT IN THE PAR.
 - ANY VERTICAL LIP THAT OCCURS AT THE FLOW LINE SHALL NOT BE GREATER THAN 1/4 INCH.
 - ① FOR USE AT CURB CUTS WHERE THE PEDESTRIAN'S PATH OF TRAVEL IS ASSUMED PERPENDICULAR TO THE GUTTER FLOW LINE. RAMP TYPES INCLUDE: PERPENDICULAR, TIERED PERPENDICULAR, PARALLEL, AND DIAGONAL RAMPS.
 - ② FOR USE AT CURB RAMPS WHERE THE PEDESTRIAN'S PATH OF TRAVEL IS ASSUMED NON PERPENDICULAR TO THE GUTTER FLOW LINE. RAMP TYPES INCLUDE: FANS & DEPRESSED CORNERS.
 - ③ BEGIN GUTTER SLOPE TRANSITION 10' OUTSIDE OF ALL CURB RAMPS.
 - ④ THERE SHALL BE NO VERTICAL DISCONTINUITIES GREATER THAN 1/4".
 - ⑤ ELEVATION CHANGE TAKES PLACE FROM THE EXISTING TO NEW FRONT OF GUTTER. PATCH IS USED TO MATCH THE NEW GUTTER FACE INTO THE EXISTING ROADWAY.
 - ⑥ VARIABLE WIDTH FOR DIRECTIONAL CURB APPLICATIONS. SEE SHEET 2 FOR DIRECTIONAL CURB SLOPE REQUIREMENTS.
 - ⑦ TOP FRONT OF GUTTER SHALL BE CONSTRUCTED FLUSH WITH PROPOSED ADJACENT PAVEMENT ELEVATION. TOP 1.5" OF THE GUTTER FACE MUST BE A FORMED EDGE. PAR GUTTER SHALL NOT BE OVERLAID.
 - ⑧ SHOULD BE USED AT VERTICALLY CONSTRAINED AREAS WHEN AT A DRAINAGE HIGH POINT OR SUPER ELEVATED ROADWAY SEGMENTS.
 - ⑨ DRILL AND GROUT NO. 4 EPOXY-COATED 18" LONG TIE BARS AT 30" CENTER TO CENTER INTO EXISTING CONCRETE PAVEMENT 1' MINIMUM FROM ALL JOINTS.
 - ⑩ HELPS PROVIDE TWO SEPARATE RAMPS, REDUCES THE DOME SETBACK LENGTH AND MINIMIZES DIRECTIONAL CURB. THIS RADIUS DESIGN CLOSELY FOLLOWS THE TURNING VEHICLE PATH WHILE OPTIMIZING CURB RAMP LENGTH.
 - ⑪ CURB EXTENSIONS SHOULD BE USED IN VERTICALLY CONSTRAINED AREAS, USUALLY IN DOWNTOWN ROADWAY SEGMENTS WHERE ON-STREET PARKING IS AVAILABLE. CURB EXTENSIONS SHOULD BE CONSIDERED FOR APS INTERSECTIONS WHERE SPACE IS LIMITED. PUSH BUTTONS MUST MEET APS CRITERIA AS DESCRIBED IN THE PUSH BUTTON LOCATION DETAIL SHEET.

REVISIONS:
APPROVED: 11-04-2021
<i>Jeff J. Perkins</i> JEFFREY PERKINS OPERATIONS DIVISION

	STANDARD PLAN 5-297.250	3 OF 6
	APPROVED: 11-04-2021 REVISOR: THOMAS STYRBICKI STATE DESIGN ENGINEER	
STATE PROJ. NO.		(TH) SHEET NO. OF SHEETS

PEDESTRIAN CURB RAMP DETAILS

DATE	REVISION

DESIGNED BY: JJF	DATE: 12/15/23
DRAWN BY: JJF	FILE: 24-02
CHECKED BY: BRW	

CITY OF RAMSEY
 7550 SUNWOOD DRIVE
 RAMSEY, MN 55303
 (763) 427-1410 FAX (763) 433-9898

MNDOT PEDESTRIAN RAMP DETAILS

HALLS DOVER ACRES STREET RECONSTRUCTIONS
CITY PROJECT NO. 24-02
CITY OF RAMSEY, MINNESOTA

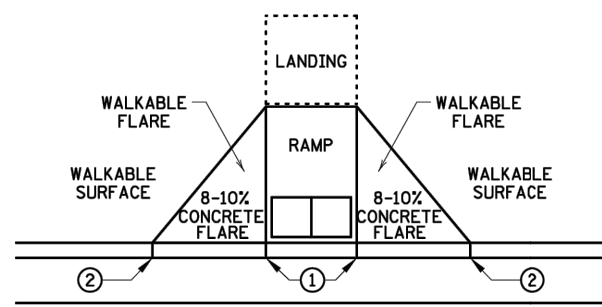

PAVED FLARES
ADJACENT TO WALKABLE SURFACE

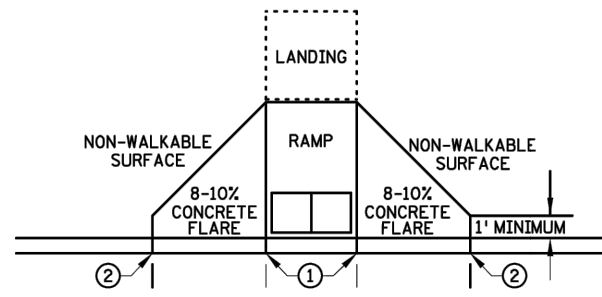

PAVED FLARES
ADJACENT TO NON-WALKABLE SURFACE

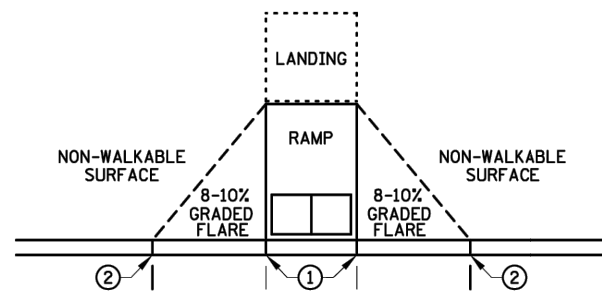

GRADED FLARES

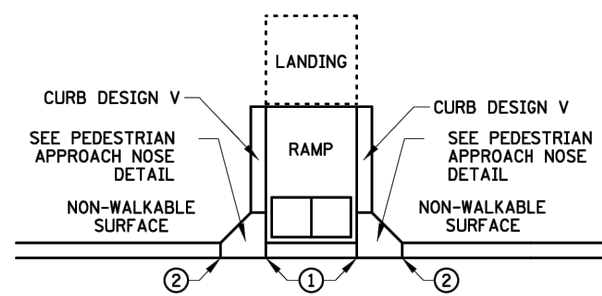

RETURNED CURB ④

TYPICAL SIDE TREATMENT OPTIONS ③ ⑩

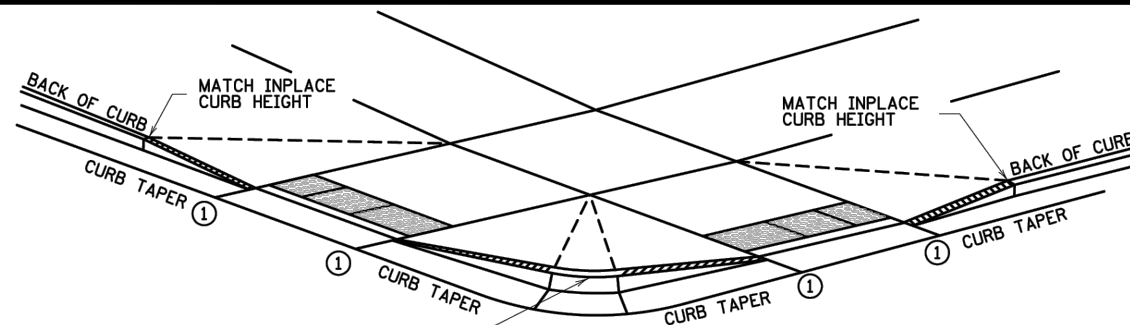

3" MINIMUM CURB HEIGHT, 4" PREFERRED
(MEASURED AT FRONT FACE OF CURB)
FOR A MIN. 6" LENGTH (MEASURED ALONG FLOW LINE)

DETECTABLE EDGE WITH
CURB AND GUTTER ⑦

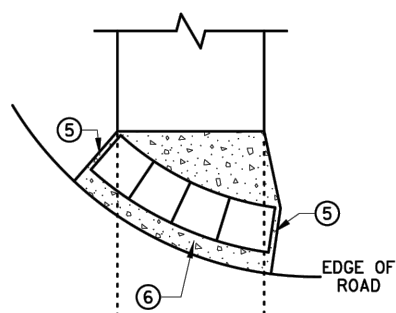

RADIAL DETECTABLE WARNING

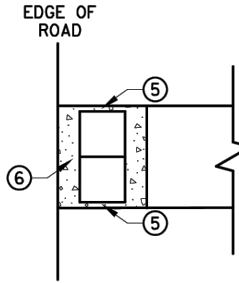

RECTANGULAR DETECTABLE WARNING

DETECTABLE EDGE WITHOUT CURB AND GUTTER

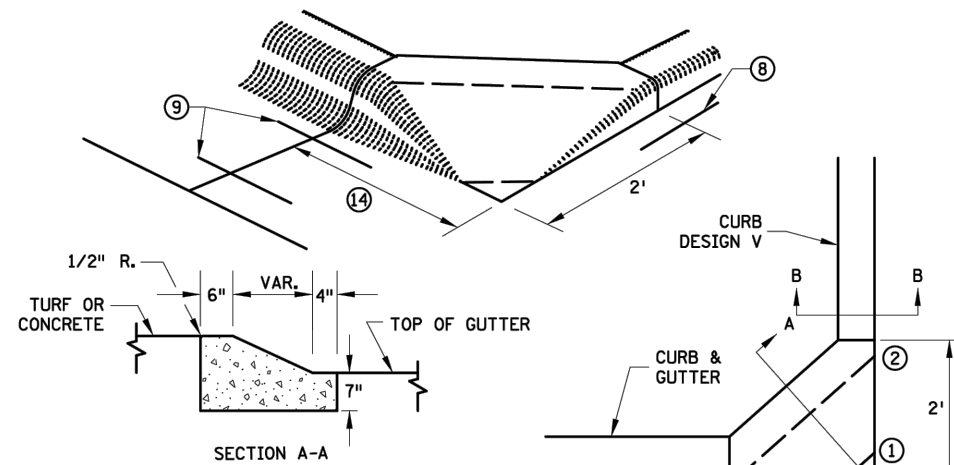

SECTION A-A

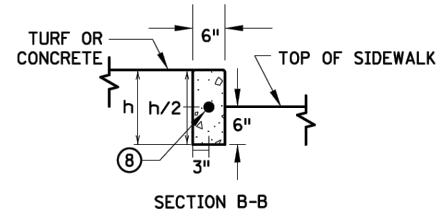

SECTION B-B

PEDESTRIAN APPROACH
NOSE DETAIL
(FOR RETURNED CURB
SIDE TREATMENT)

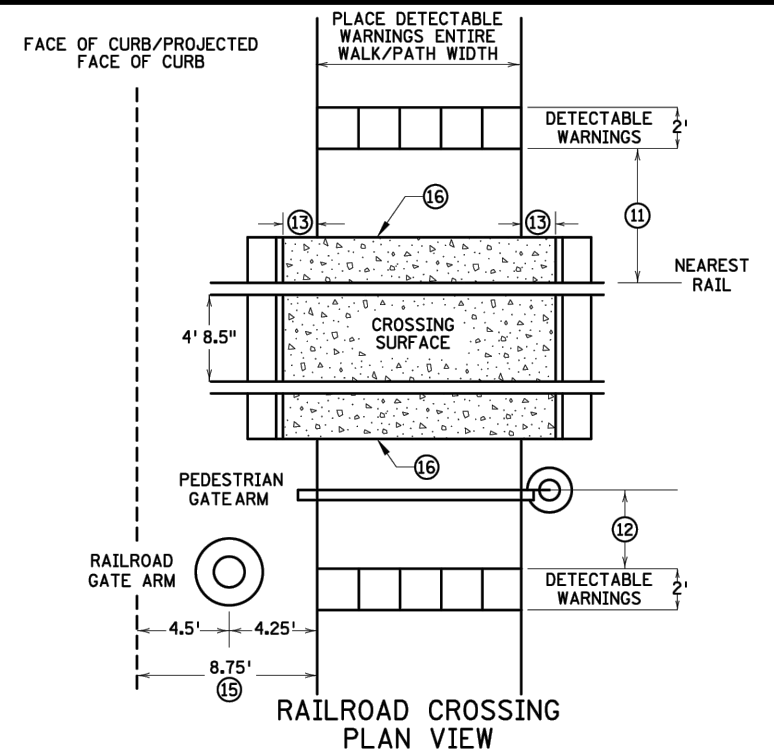

RAILROAD CROSSING
PLAN VIEW

NOTES:

- INTERMEDIATE CURB HEIGHTS TAPER SHALL RISE AT 8-10% TO A MINIMUM 3 INCH CURB HEIGHT. INCREASE CURB TAPER LENGTH AT LESS THAN 8% OR REDUCE INTERMEDIATE CURB HEIGHT TO 2+ INCHES IF NECESSARY TO MATCH ADJACENT BOULEVARD OR SIDEWALK GRADES.
- SEE STANDARD PLATE 7038 AND THIS SHEET FOR ADDITIONAL DETAILS ON DETECTABLE WARNING.
- A WALKABLE SURFACE IS DEFINED AS A PAVED SURFACE ADJACENT TO A CURB RAMP WITHOUT RAISED OBSTACLES THAT COULD MISTAKENLY BE TRAVERSED BY A USER WHO IS VISUALLY IMPAIRED.
- CONCRETE FLARE LENGTHS ADJACENT TO NON-WALKABLE SURFACES SHOULD BE LESS THAN 8' LONG MEASURED ALONG THE RAMPS FROM THE BACK OF CURB.
- ① 0" CURB HEIGHT. SEE INSET A ON SHEET 3 OF 6.
- ② FULL CURB HEIGHT.
- ③ SIDE TREATMENTS ARE APPLICABLE TO ALL RAMP TYPES AND SHOULD BE IMPLEMENTED AS NEEDED AS FIELD CONDITIONS DICTATE. THE ENGINEER SHALL DETERMINE THE RAMP SIDE TREATMENTS BASED ON MAINTENANCE OF BOTH ROADWAY AND SIDEWALK, ADJACENT PROPERTY CONSIDERATIONS, AND MITIGATING CONSTRUCTION IMPACTS.
- ④ TYPICALLY USED FOR MEDIANS AND ISLANDS.
- ⑤ WHEN NO CONCRETE FLARES ARE PROPOSED, THE CONCRETE WALK SHALL BE FORMED AND CONSTRUCTED PERPENDICULAR TO THE EDGE OF ROADWAY. MAINTAIN 3" MAX. BETWEEN EDGE OF DOMES AND EDGE OF CONCRETE.
- ⑥ IF NO CURB AND GUTTER IS PLACED IN RURAL SECTIONS, DETECTABLE WARNINGS SHALL BE PLACED 1' FROM THE EDGE OF BITUMINOUS ROADWAY AND/OR BITUMINOUS SHARED-USE PATH TO PROVIDE VISUAL CONTRAST.
- ⑦ ALL CONSTRUCTED CURBS MUST HAVE A CONTINUOUS DETECTABLE EDGE FOR THE VISUALLY IMPAIRED. THIS DETECTABLE EDGE REQUIRES DETECTABLE WARNINGS WHEREVER THERE IS ZERO-INCH HIGH CURB. CURB TAPERS ARE CONSIDERED A DETECTABLE EDGE WHEN THE TAPER STARTS WITHIN 3" OF THE EDGE OF THE DETECTABLE WARNINGS, AND UNIFORMLY RISES TO A 3-INCH MINIMUM CURB HEIGHT. ANY CURB NOT PART OF A CURB TAPER AND LESS THAN 3 INCHES IN HEIGHT IS NOT CONSIDERED A DETECTABLE EDGE AND THEREFORE IS NOT COMPLIANT WITH ACCESSIBILITY STANDARDS.
- ⑧ DRILL AND GROUT 1 - NO. 4 12" LONG REINFORCEMENT BAR (EPOXY COATED) WITH 3" MIN. COVER. REINFORCEMENT BARS ARE NOT NEEDED IF THE APPROACH NOSE IS POURED INTEGRAL WITH THE V CURB.
- ⑨ DRILL AND GROUT 2 - NO. 4 12" LONG REINFORCEMENT BARS (EPOXY COATED) WITH 3" MIN. COVER. REINFORCEMENT BARS ARE NOT NEEDED IF THE APPROACH NOSE IS POURED INTEGRAL WITH THE CURB AND GUTTER.
- ⑩ SIDE TREATMENT EXAMPLES SHOWN ARE WHEN THE INITIAL LANDING IS APPROXIMATELY LEVEL WITH THE FULL HEIGHT CURB (I.E. 6' LONG RAMP FOR 6" HIGH CURB). WHEN THE INITIAL LANDING IS MORE THAN 1" BELOW FULL HEIGHT CURB REFER TO SHEETS 1 & 2 TO MODIFY THE CURB HEIGHT TAPERS AND MAINTAIN POSITIVE BOULEVARD DRAINAGE. CONSTRUCT THESE TAPERS AT 0"-3" AT 8-10%, THEN LESS THAN 5% FROM 3" CURB TO FULL CURB HEIGHT.
- ⑪ NEAREST EDGE OF DETECTABLE WARNING SURFACES SHALL BE PLACED 12' MINIMUM TO 15' MAXIMUM FROM THE NEAREST RAIL. FOR SKEWED RAILWAYS IN NO INSTANCE SHALL THE DETECTABLE WARNING BE CLOSER THAN 12' MEASURED PERPENDICULAR TO THE NEAREST RAIL.
- ⑫ WHEN PEDESTRIAN GATES ARE PROVIDED, DETECTABLE WARNING SURFACES SHALL BE PLACED ON THE SIDE OF THE GATES OPPOSITE THE RAIL, 2' FROM THE APPROACHING SIDE OF THE GATE ARM. THIS CRITERIA GOVERNS OVER NOTE ⑪.
- ⑬ CROSSING SURFACE SHALL EXTEND 2' MINIMUM PAST THE OUTSIDE EDGE OF WALK OR SHARED-USE PATH.
- ⑭ 3' FOR MEDIANS AND SPLITTER ISLANDS. NOSE CAN BE REDUCED TO 2' ON FREE RIGHT ISLANDS.
- ⑮ SIDEWALK TO BE PLACED 8.75' MIN. FROM THE FACE OF CURB/PROJECTED FACE OF CURB. THIS ENSURES MIN. CLEARANCE BETWEEN THE SIDEWALK AND GATE ARM COUNTERWEIGHT SUPPORTS.
- ⑯ CONSTRUCT WITH EXPANSION MATERIAL PER MNDOT SPECIFICATION 3702 TYPES A-E. EXPANSION MATERIAL SHALL MATCH FULL HEIGHT OF ADJACENT CONCRETE.

REVISION:
APPROVED: 11-04-2021
<i>Jeff J. Perkins</i>
JEFFREY PERKINS OPERATIONS DIVISION

	STANDARD PLAN 5-297.250	4 OF 6
	APPROVED: 11-04-2021 REVISION:	
THOMAS STYBICKI STATE DESIGN ENGINEER	STATE PROJ. NO.	(TH) SHEET NO. OF SHEETS

PEDESTRIAN CURB RAMP DETAILS

DATE	REVISION

DESIGNED BY: JJF	DATE: 12/15/23
DRAWN BY: JJF	FILE: 24-02
CHECKED BY: BRW	

CITY OF RAMSEY
 7550 SUNWOOD DRIVE
 RAMSEY, MN 55303
 (763) 427-1410 FAX (763) 433-9898

MNDOT PEDESTRIAN RAMP DETAILS

HALLS DOVER ACRES STREET RECONSTRUCTIONS
 CITY PROJECT NO. 24-02
 CITY OF RAMSEY, MINNESOTA

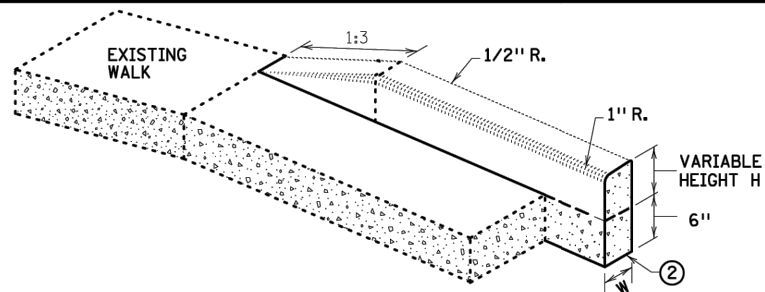

V CURB ADJACENT TO LANDSCAPE
CURB WITHIN SIDEWALK LIMITS

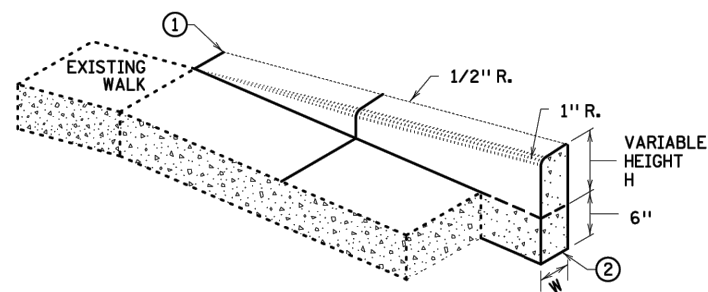

V CURB ADJACENT TO LANDSCAPE
CURB OUTSIDE SIDEWALK LIMITS

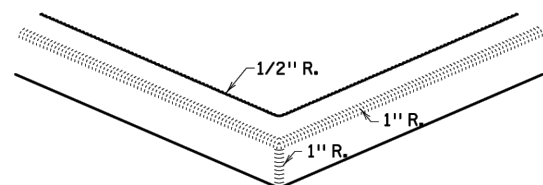

V CURB INTERSECTION

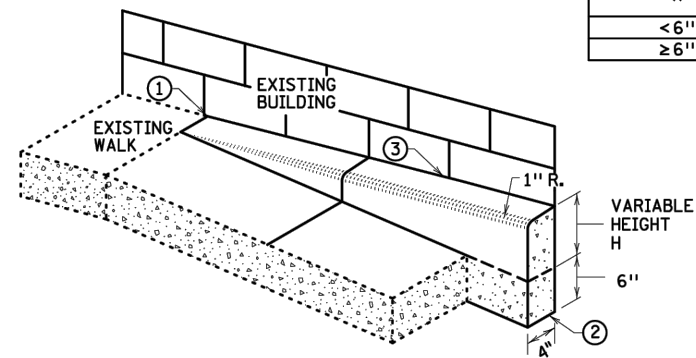

V CURB ADJACENT TO BUILDING
OR BARRIER

CONCRETE CURB DESIGN V	
CURB HEIGHT H	CURB WIDTH W
< 6"	4"
≥ 6"	6"

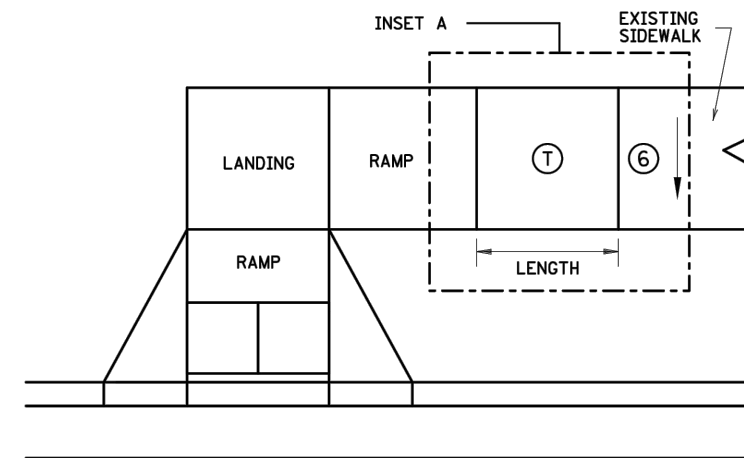

TRANSITION PANEL ④ ⑤

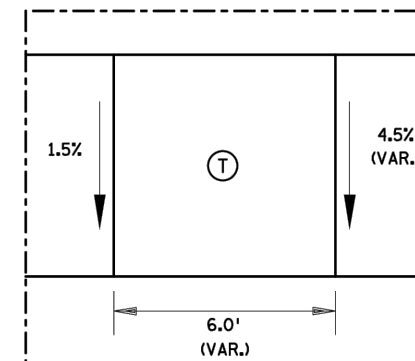

INSET A

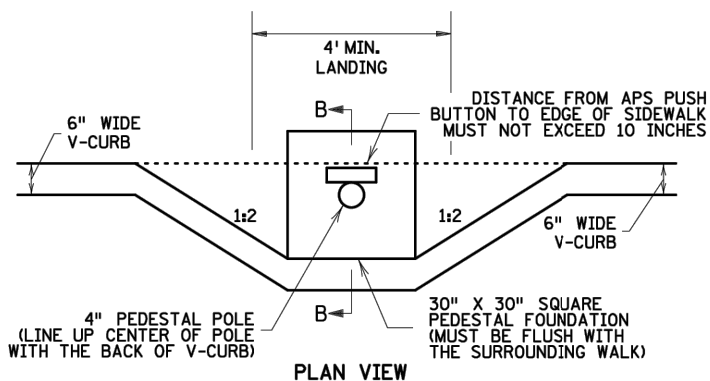

PLAN VIEW

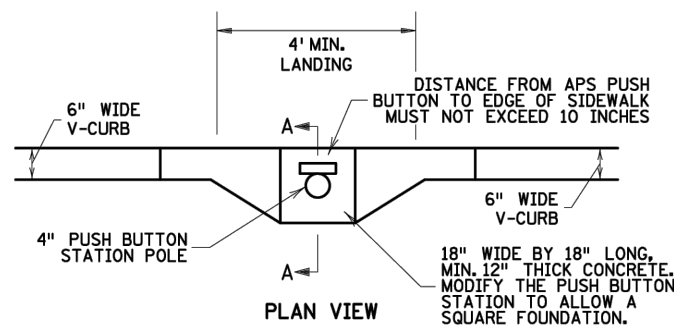

PLAN VIEW

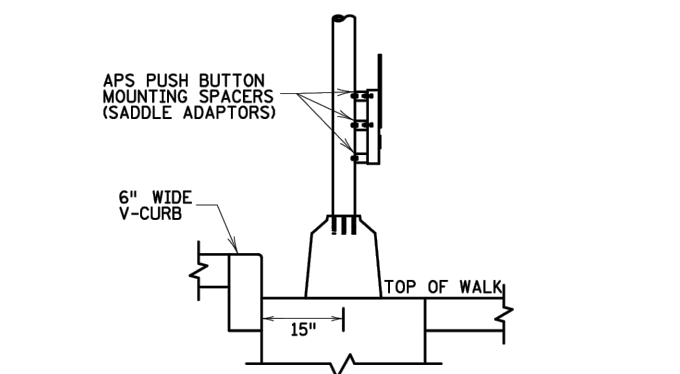

SECTION B-B
SIGNAL PEDESTAL & PUSH BUTTON (V-CURB)

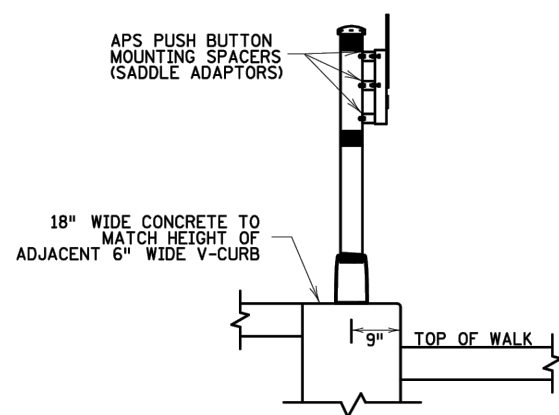

SECTION A-A
PUSH BUTTON STATION (V-CURB)

NOTES:

A WALKABLE FLARE IS AN 8-10% CONCRETE FLARE THAT IS REQUIRED WHEN THE FLARE IS ADJACENT TO A WALKABLE SURFACE, OR WHEN THE PEDESTRIAN PATH OF TRAVEL OF A PUSH BUTTON TRAVERSES THE FLARE.

ALL V CURB CONTRACTION JOINTS SHALL MATCH CONCRETE WALK JOINTS.

WHERE RIGHT-OF-WAY ALLOWS, USE OF V CURB SHOULD BE MINIMIZED. GRADING ADJACENT TURF OR SLOPING ADJACENT PAVEMENT IS PREFERRED.

V CURB SHALL BE PLACED OUTSIDE THE SIDEWALK LIMITS WHEN RIGHT OF WAY ALLOWS.

V CURB NEXT TO BUILDING SHALL BE A 4" WIDTH AND SHALL MATCH PREVIOUS TOP OF SIDEWALK ELEVATIONS.

- ① END TAPERS AT TRANSITION SECTION SHALL MATCH INPLACE SIDEWALK GRADES.
- ② ALL V CURB SHALL MATCH BOTTOM OF ADJACENT WALK.
- ③ CONSTRUCT USING APPROVED EXPANSION MATERIAL PER MNDOT TYPE A-E EXPANSION. LEAVE A MINIMUM 1/2" TOP GAP AND SEAL WITH MNDOT APPROVED SILICONE PER MNDOT SPEC 3722.
- ④ THE MAX. RATE OF CROSS SLOPE TRANSITIONING IS 1' LINEAR FOOT OF SIDEWALK PER HALF PERCENT CROSS SLOPE. WHEN PAR WIDTH IS GREATER THAN 6' OR THE RUNNING SLOPE IS GREATER THAN 5%, DOUBLE THE CALCULATED TRANSITION LENGTH.
- ⑤ TRANSITION PANELS ARE TO ONLY BE USED AFTER THE RAMP, OR IF NEEDED, LANDING ARE AT THE FULL CURB HEIGHT (TYPICAL SECTION).
- ⑥ EXISTING CROSS SLOPE GREATER THAN 2.0%.

LEGEND

THESE LONGITUDINAL SLOPE RANGES SHALL BE THE STARTING POINT. IF SITE CONDITIONS WARRANT, LONGITUDINAL SLOPES UP TO 8.3% OR FLATTER ARE ALLOWED.

- ⑤ INDICATES PEDESTRIAN RAMP - SLOPE SHALL BE BETWEEN 5.0% MINIMUM AND 8.3% MAXIMUM IN THE DIRECTION SHOWN AND THE CROSS SLOPE SHALL NOT EXCEED 2.0%.
- LANDING AREA - 4' X 4' MIN. (5' X 5' MIN. PREFERRED) DIMENSIONS AND MAX 2.0% SLOPE IN ALL DIRECTIONS. LANDING SHALL BE FULL WIDTH OF INCOMING PARS.
- ① TRANSITION PANEL(S) - TO BE USED FOR TRANSITIONING THE CROSS-SLOPE OF A RAMP TO THE EXISTING WALK CROSS-SLOPE. RATE OF TRANSITION SHOULD BE 0.5% PER 1 LINEAR FOOT OF WALK. SEE THIS SHEET FOR ADDITIONAL INFORMATION.

DATE	REVISION

DESIGNED BY: JJF	DATE: 12/15/23
DRAWN BY: JJF	FILE: 24-02
CHECKED BY: BRW	



CITY OF RAMSEY
7550 SUNWOOD DRIVE
RAMSEY, MN 55303
(763) 427-1410 FAX (763) 433-9898



STANDARD PLAN 5-297.250 5 OF 6
APPROVED: 11-04-2021
REVISOR:
THOMAS TYRIBICKI
STATE DESIGN ENGINEER

PEDESTRIAN CURB RAMP DETAILS

STATE PROJ. NO. (TH) SHEET NO. OF SHEETS

MNDOT PEDESTRIAN RAMP DETAILS

HALLS DOVER ACRES STREET RECONSTRUCTIONS
CITY PROJECT NO. 24-02
CITY OF RAMSEY, MINNESOTA

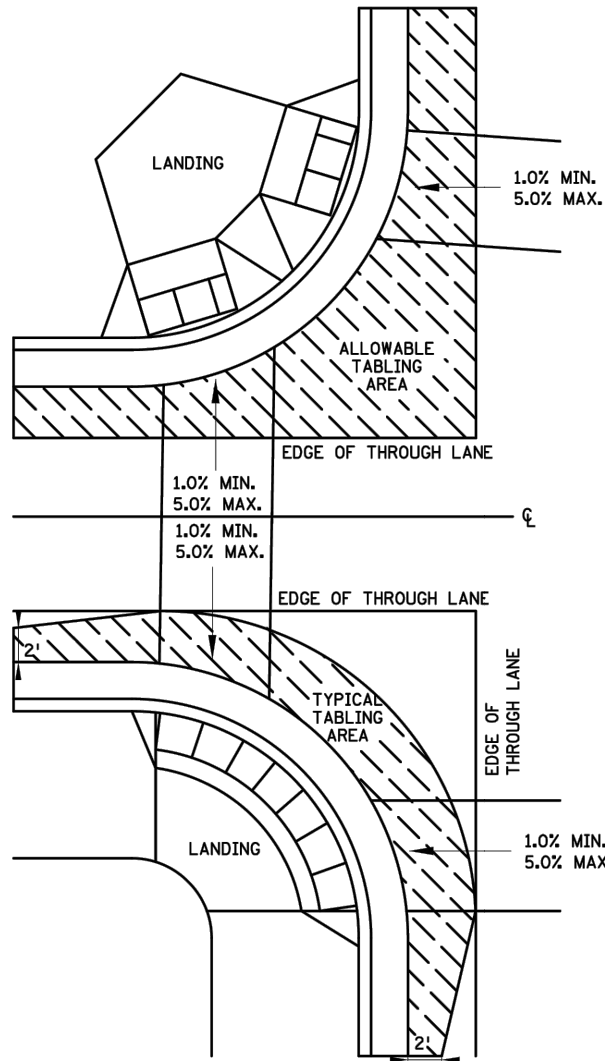

CURB LINE AND ROAD CROSSING ADJUSTMENTS

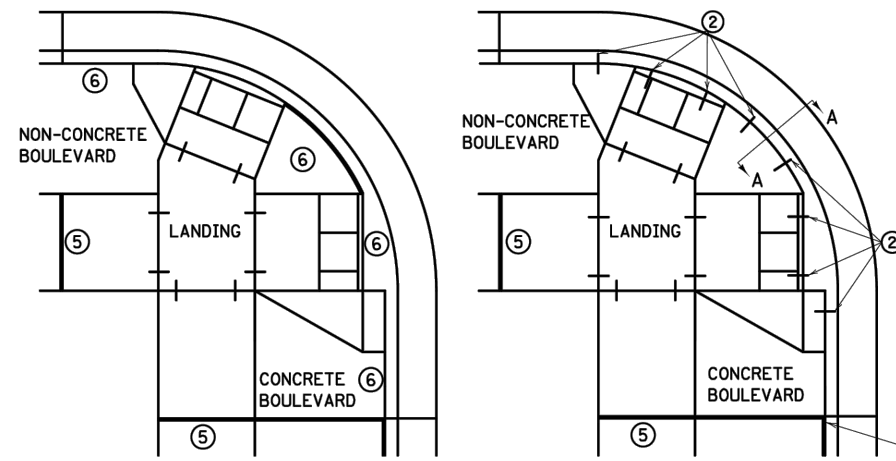

EXPANSION MATERIAL PLACEMENT FOR CONCRETE ROADWAYS

CURB LINE REINFORCEMENT PLACEMENT ON BITUMINOUS ROADWAYS

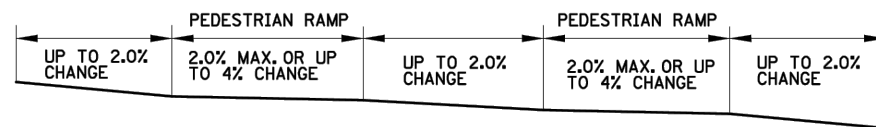

FLOW LINE PROFILE "TABLE" - TWIN PERPENDICULARS

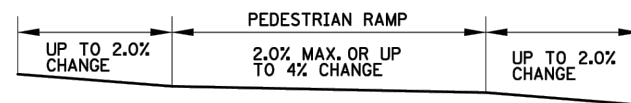

FLOW LINE PROFILE "TABLE" - FAN

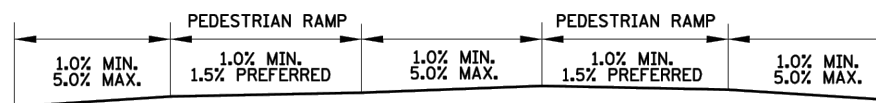

FLOW LINE PROFILE RAISE - TWIN PERPENDICULARS

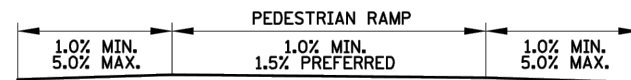

FLOW LINE PROFILE RAISE - FAN

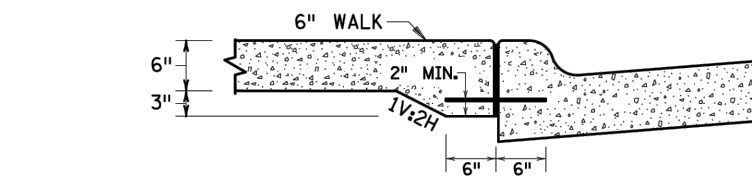

SECTION VIEW A-A THICKENED SECTION THROUGH CURB RAMP FLARES

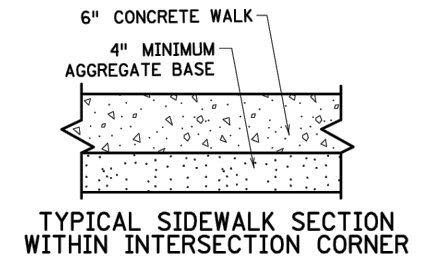

TYPICAL SIDEWALK SECTION WITHIN INTERSECTION CORNER

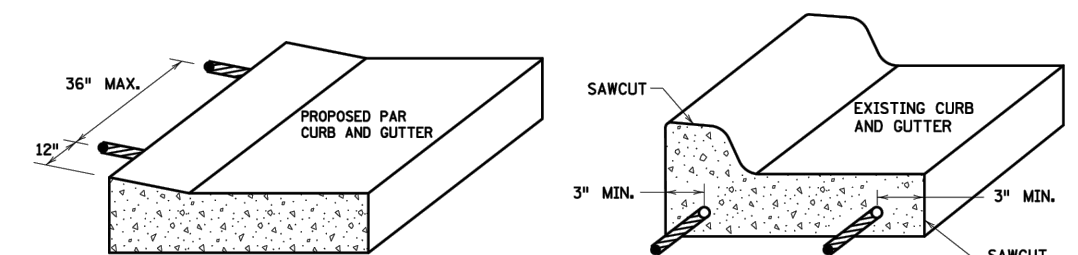

CURB RAMP REINFORCEMENT DETAILS

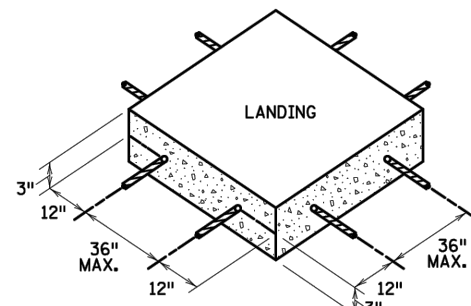

SEPARATE LANDING POUR REINFORCEMENT

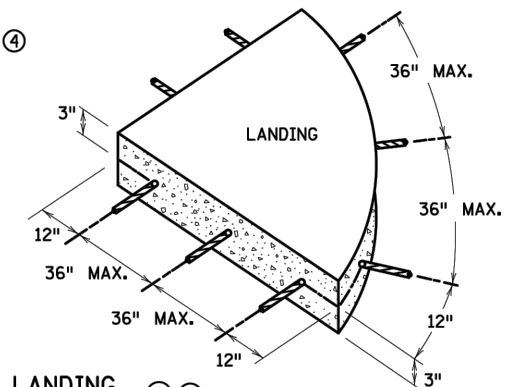

CURB AND GUTTER REINFORCEMENT

GENERAL NOTES:

"TABLING" OF CROSSWALKS MEANS MAINTAINING LESS THAN 2% CROSS SLOPE WITHIN A CROSSWALK, IS REQUIRED WHEN A ROADWAY IS IN A STOP OR YIELD CONDITION AND THE PROJECT SCOPE ALLOWS.

RECONSTRUCTION PROJECTS: ON FULL PAVEMENT REPLACEMENT PROJECTS "TABLING" OF ENTIRE CROSSWALK SHALL OCCUR WHEN FEASIBLE.

MILL & OVERLAY PROJECTS: "TABLING" OF FLOW LINES, IN FRONT OF THE PEDESTRIAN RAMP, IS REQUIRED WHEN THE EXISTING FLOW LINE IS GREATER THAN 2%. WARPING OF THE BITUMINOUS PAVEMENT CAN NOT EXTEND INTO THE THROUGH LANE. TABLE THE FLOW LINE TO 2% OR AS MUCH AS POSSIBLE WHILE ADHERING TO THE FOLLOWING CRITERIA:

- 1) 1.0% MIN. CROSS-SLOPE OF THE ROAD
- 2) 5.0% MAX. CROSS-SLOPE OF THE ROAD
- 3) "TABLE" FLOW LINE UP TO 4% CHANGE FROM EXISTING SLOPE IN FRONT OF PEDESTRIAN RAMP
- 4) UP TO 2% CHANGE IN FLOW LINE FROM EXISTING SLOPE BEYOND THE PEDESTRIAN CURB RAMP

STAND-ALONE ADA RETROFITS: FOLLOW MILL & OVERLAY CRITERIA ABOVE HOWEVER ALL PAVEMENT WARPING IS DONE WITH BITUMINOUS PATCHING ON BITUMINOUS ROADWAYS AND FULL-DEPTH APRON REPLACEMENT ON CONCRETE ROADWAYS.

RAISING OF CURB LINES SHOULD OCCUR IN VERTICALLY CONSTRAINED AREAS. RAISE THE CURB LINES ENOUGH TO ALLOW COMPLIANT RAMPS OR AS MUCH AS POSSIBLE WHILE ADHERING TO THE FOLLOWING CRITERIA:

- 1) 1.0% MIN. AND 5.0% MAXIMUM CROSS-SLOPE OF THE ROAD
- 2) 1.0% MIN. FLOW LINE (ON EITHER SIDE OF PEDESTRIAN RAMP) TO MAINTAIN POSITIVE DRAINAGE
- 3) 5.0% RECOMMENDED MAX. FLOW LINE
- 4) LONGITUDINAL THROUGH LANE ROADWAY TAPERS SHOULD BE 1" VERTICAL PER 15' HORIZONTAL

NOTES:

- 1) TO ENSURE RAMPS AND LANDINGS ARE PROPERLY CONSTRUCTED, ALL INITIAL LANDINGS AT A TOP OF A RAMPED SURFACE (RUNNING SLOPE GREATER THAN 2%) SHALL BE FORMED AND PLACED SEPARATELY IN AN INDEPENDENT CONCRETE POUR. FOLLOW SIDEWALK REINFORCEMENT DETAILS ON THIS SHEET FOR ALL SEPARATELY Poured INITIAL LANDINGS.
- 2) DRILL AND GROUT NO. 4 12" LONG REINFORCEMENT BARS (EPOXY COATED) AT 36" MAXIMUM CENTER TO CENTER MINIMUM 12" SPACING FROM CONSTRUCTION JOINTS. BARS TO BE ADJUSTED TO MATCH RAMP GRADE. BARS TO BE PAID BY EACH.
- 3) DRILL AND GROUT 2 - NO. 4 X 12" LONG (6" EMBEDDED) REINFORCEMENT BARS (EPOXY COATED). REINFORCEMENT REQUIRED FOR ALL CONSTRUCTION JOINTS. BARS TO BE PAID BY EACH.
- 4) THIS CURB LINE REINFORCEMENT DETAIL SHALL BE USED ON BITUMINOUS ROADWAYS. FOR CONCRETE ROADWAYS, SEE NOTE 6.
- 5) CONSTRUCT WITH EXPANSION MATERIAL PER MNDOT SPECIFICATION 3702 TYPES A-E. EXPANSION MATERIAL SHALL MATCH FULL HEIGHT OF ADJACENT CONCRETE.
- 6) USE AN APPROVED TYPE F (1/4 INCH THICK) SEPARATION MATERIAL. SEPARATION MATERIAL SHALL MATCH FULL HEIGHT DIMENSION OF ADJACENT CONCRETE.

REVISION:
APPROVED: 11-04-2021
<i>Jeff J. Perkins</i>
JEFFREY PERKINS OPERATIONS DIVISION



STANDARD PLAN 5-297.250 6 OF 6
APPROVED: 11-04-2021
REVISOR:
THOMAS STYBRICKI
STATE DESIGN ENGINEER

PEDESTRIAN CURB RAMP DETAILS

STATE PROJ. NO. (TH) SHEET NO. OF SHEETS

MNDOT PEDESTRIAN RAMP DETAILS

HALLS DOVER ACRES STREET RECONSTRUCTIONS
CITY PROJECT NO. 24-02
CITY OF RAMSEY, MINNESOTA

STORM WATER POLLUTION PREVENTION PLAN (SWPPP)

HALLS DOVER ACRES STREET RECONSTRUCTIONS IMPROVEMENT PROJECT 24-02 CITY OF RAMSEY ANOKA COUNTY, MINNESOTA

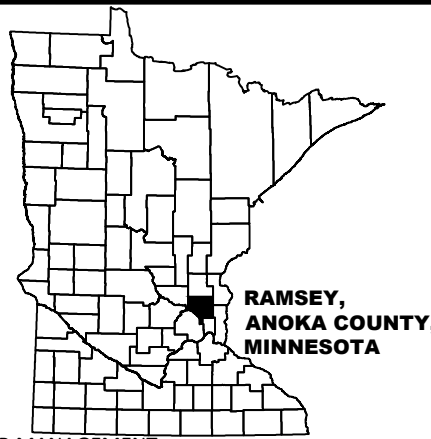

DESCRIPTION OF CONSTRUCTION ACTIVITIES AND STORMWATER MANAGEMENT:
 Construction activities include; Site Grading, Storm Sewer Construction, Temporary Erosion and Sediment Control, Roadway Construction, Utility Construction, and Permanent Stabilization.
 Project Description: This project consists of reconstruction of 0.98 miles of existing bituminous streets and construction of 0.40 miles of trunk watermain. The drainage for the existing streets uses swales adjacent to the pavement, carrying runoff to low existing low areas. The proposed improvements do not alter the existing drainage patterns, which generally carry runoff to the existing wetlands south of the project area. There is no change to the outfall location of the storm water runoff proposed with this project.

RESPONSIBLE PARTIES:
 The Contractor and Owner must apply for coverage under the MPCA's General Storm Water Permit for Construction Activity as required by the National Pollution Discharge Elimination System (NPDES) Phase II program. Coverage under the permit will begin automatically 7 calendar days after the electronic submittal date or after the postmarked date of a complete application. (Longer time frames will apply to areas disturbing 50 acres or marked within 1 mile of a special water).

	COMPANY	CONTACT PERSON	PHONE
OWNER:	CITY OF RAMSEY	BRUCE WESTBY, PE	763-433-9825
SWPPP DESIGNER:	CITY OF RAMSEY	JOE FERIANCEK, PE	763-433-9893
CONTRACTOR:			
STIE MANAGER:			
PARTY RESPONSIBLE FOR LONG TERM O&M:	CITY OF RAMSEY	BRUCE WESTBY, PE	763-433-9825

Individuals listed above, including the SWPPP preparer, individual overseeing implementation of, revising and amending the SWPPP, Individuals performing or supervising the installation, maintenance and repair of BMP's must be trained. At least one individual present on the permitted project, or available within 72 hours shall be trained in the applicable job duties. Documentation showing training commensurate with the job duties and responsibilities is required to be included in the SWPPP prior to any work beginning on the site. Copies of the SWPPP preparer information is included in the Project Manual. The Contractor shall provide information for the individual(s) overseeing implementation, supervising installation, maintenance, and repair of BMP's to be included in the Project Manual prior to the start of construction. This information shall be kept up to date until the project NOT is filed.

Documentation shall include:
 a. Names of trained personnel associated with this project.
 b. Dates of training, names of instructor(s) and entity providing training.
 c. Content of training course or workshop including the number of hours trained.
 d. As an alternative to a, b, and c listed above, a photocopy of the current Erosion and Stormwater Management card issued by the University of Minnesota can be attached to the SWPPP as suitable documentation of training.

DOCUMENTATION RETENTION:
 The following documentation will be retained for a period of not less than 3-years from the date of submittal of the NOT.
 1. The final SWPPP.
 2. Copies of all stormwater related permits required for the project.
 3. Records of all inspection and maintenance conducted during construction.
 4. Copies of all permanent operation and maintenance agreements; including all right-of-way, contracts, covenants and other binding requirements regarding perpetual maintenance.
 5. All required calculations for design of temporary and permanent BMP's.

- IMPLEMENTATION SCHEDULE AND PHASING:**
- Furnish & Install perimeter sediment control and inlet protection.
 - Reclamation of existing bituminous pavement.
 - Rough grade site.
 - Furnish & install bituminous pavement.
 - Add additional temporary BMP's as necessary during construction based on inspection reports.
 - Submit Notice of Termination (NOT) to MPCA within 30 days of final stabilization.

- FINAL STABILIZATION:**
 The permittee(s) must ensure final stabilization of the site. The permittee(s) must submit a NOT within 30 days after final stabilization is complete, or another owner/operator (permittee) has assumed control over all areas of the site which have not undergone final stabilization. Final stabilization can be achieved in one of the following ways:
- All soil disturbing activities at the site have been completed and all soils must be stabilized by a uniform perennial vegetative cover with a density of 70 percent over the entire pervious surface area, or other equivalent means necessary to prevent soil failure under erosive conditions and;
 - All drainage ditches, constructed to drain water from the site after construction is complete, must be stabilized to preclude erosion;
 - All temporary synthetic, and structural erosion prevention and sediment control BMP's (such as silt fence) must be removed as part of the site final stabilization; and
 - The permittee(s) must clean out all sediment from conveyances and from temporary sedimentation basins to be used as permanent water quality management basins. Sediment must be stabilized to prevent it from being washed back into the basin, conveyances or drainage ways discharging off-site or to surface waters. The cleanout of permanent basins must be sufficient to return the basin to design capacity.
 - Final vegetation cover shall be in the Project Specifications.
 - For residential construction only, final stabilization has been achieved when temporary erosion protection and down gradient perimeter control for individual lots has been completed and the residence has been transferred to the homeowner. Additionally, the permittee must distribute the MPCA "Homeowner fact sheet" to the homeowner to inform the homeowner of the need for, and benefits of, final stabilization.

SPECIAL ENVIRONMENTAL CONSIDERATIONS:

Was an environmental review required for this project or any part of a common plan of development or sale that includes all or any portion of this project?	NO
Does any portion of the site have the potential to affect threatened or endangered species?	NO
Does any portion of this site discharge to a Calcareous Fen and the letter of approval from the DNR is located in the Project Manual?	NO
Will any portion of this site potentially affect properties listed on the National Register of Historic Places or a Known or Discovered Archeological site?	NO
Have any Karst features been identified in the project vicinity?	NO
Is compliance with temporary or permanent stormwater management design requirements infeasible for this project?	NO

- POLLUTION PREVENTION MANAGEMENT MEASURES:**
 The permittee(s) shall implement the following pollution prevention management measures on the site:
- Solid waste: collected sediment, asphalt and concrete millings, floating debris, paper, plastic, fabric, construction and demolition debris and other wastes must be disposed of properly and must comply with MPCA disposal regulations.
 - Hazardous materials: oil, gasoline, paint and any hazardous substances must be properly stored, including secondary containment, to prevent spills, leaks or other discharge. Restricted access to storage areas must be provided to prevent vandalism. Storage and disposal of hazardous waste must be in compliance with MPCA regulations.
 - External washing of trucks and other construction vehicles must be limited to a defined area of the site. Runoff must be contained and waste properly disposed of. No engine degreasing is allowed on site.

- GENERAL STORMWATER DISCHARGE REQUIREMENTS:**
 All requirements listed in Part 15 of the permit for the design of permanent stormwater treatment system and discharge have been included in the preparation of this SWPPP. These include but are not limited to:
- The expected amount, frequency, intensity and duration of precipitation.
 - The nature of stormwater runoff and run-on at the site.
 - Peak flow rates and stormwater volumes to minimize erosion at outlets and downstream channel and stream bank erosion.
 - The range of soil particle sizes expected to be present on the site.

RECEIVING WATERS:
 Receiving waters, including surface water, wetlands, Public Waters, and stormwater ponds are identified on the USGS 7.5min quad map within 1 mile of the project boundary. Receiving waters that are impaired, the impairment and WLA are listed as follows. All specific BMP's relative to construction activities listed in this permit for special and impaired waters have been incorporated into this plan. All specific BMP's listed in approved TMDLs and those BMP's listed for construction related waste load allocations have also been incorporated.

NAME OF WATER BODY	TYPE (DITCH, POND, WETLAND, LAKE, ETC.)	APPENDIX A SPECIAL WATER?	FLOWS TO IMPAIRED WATER WITHIN 1 MILE?	USEPA APPROVED TMDL?
RUM RIVER	RIVER	YES	YES	YES

DO; FISHESBIO; INVERTBIO

PROJECT AREAS:
 Total project size (disturbed area) = 5.17 ACRES
 Existing area of impervious surface = 3.25 ACRES
 Post construction area of impervious surface = 3.18 ACRES
 New impervious surface area created = -0.07 ACRES

Planned construction start date: June 2024
 Planned construction completion date: August 2024

PROJECT LOCATION:
 County: ANOKA Township: 32 Range: 25 Section: 14 Latitude: 45.257379 Longitude: -93.421041

PERMANENT STORMWATER MANAGEMENT SYSTEM:
 Type of storm water management used if more than 1 acre of new impervious surface is created:
 a. Wet Sedimentation Pond
 b. Infiltration / Filtration
 c. Regional Pond
 d. Permanent Stormwater Management Not Required

LOCATION OF SWPPP REQUIREMENTS IN PROJECT PLAN:

DESCRIPTION	LOCATION
TEMPORARY EROSION CONTROL MEASURES	SHEETS No.
FINAL STABILIZATION	47 - 53
STORM SEWER TABULATION	32 - 41
EROSION AND SEDIMENT CONTROL DETAILS	18 - 24

EROSION AND SEDIMENT CONTROL QUANTITIES:

DESCRIPTION	QUANTITY
SILT FENCE TYPE MS	2921 LF
TREE SAVE FENCE	20 LF
EROSION CONTROL LOG	575 LF
INLET PROTECTION	2 EA
EROSION BLANKET CATEGORY 20	2234 SY
CONSTRUCTION EXIT	4 EA

CERTIFICATION:

UNIVERSITY OF MINNESOTA

Joe Feriancek

Design of Construction SWPPP (May 31 2026)

Erosion and Stormwater Management

The bearer of this card has been tested and is certified in the areas shown on the reverse of this card. Certification expiration dates appear after each certification area.

Joe Feriancek
 Department of Materials and Biosystems Engineering
 University of Minnesota
 http://www.erosion.com.edu
 Card Issued: 01/2022

LEGEND

- PROJECT LIMITS
- 1 MILE LIMIT
- RECEIVING WATER
- IMPAIRED WATER

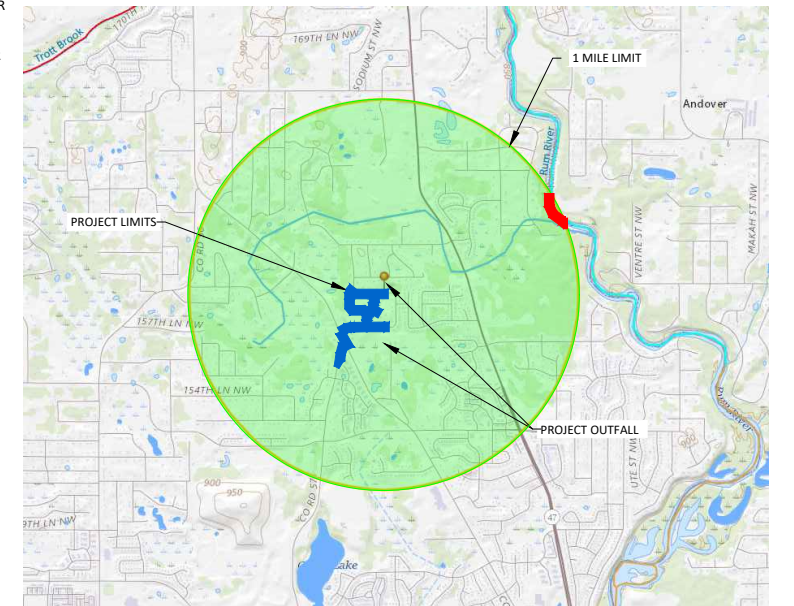

DATE	REVISION

I hereby certify that this plan, specification, or report was prepared by me or under my direct supervision and that I am a duly Licensed Professional Engineer Under the laws of the State of Minnesota

JOE FERIANCEK
 Date: 4/23/24 Lic. No. 57095

DESIGNED BY: JJF
 DRAWN BY: JJF DATE: 12/15/23
 CHECKED BY: BRW FILE: 24-02

CITY OF RAMSEY
 7550 SUNWOOD DRIVE
 RAMSEY, MN 55303
 (763) 427-1410 FAX (763) 433-9898

SWPPP

HALLS DOVER ACRES STREET RECONSTRUCTIONS CITY PROJECT NO. 24-02 CITY OF RAMSEY, MINNESOTA

SHEET 16 OF 65 SHEETS

SEQUENCE OF CONSTRUCTION:

Construction shall proceed in the following sequence:

1. Contractor shall schedule and conduct a pre-construction meeting with the City.
2. Contractor shall secure all necessary permits and licenses.
3. Furnish & install erosion control measures.
4. Maintain erosion control measures, i.e. silt fence, inlet protection.
5. Remove existing bituminous pavement and base.
6. Install utilities; backfill excavation, grade and compact as required.
7. Furnish & install aggregate base, base course of bituminous pavement
8. Install restoration per plan.
9. Furnish & install wear course of bituminous pavement.
10. Remove erosion control after vegetation is established.

ADDITIONAL STORMWATER POLLUTION PREVENTION, GRADING PLAN, AND SCHEDULE NOTES:

1. All slopes to be 1:4 unless approved by the city engineer.
2. Below grade structures shall be protected and meet drainage requirements per the city engineer.
3. Construction operation hours are from 7:00 a.m. - 10:00 p.m. Monday through Saturday.
4. Call Gopher State One Call for utility locations prior to any work at 1-800-252-1166.
5. Permittee may need to modify SWPPP if the general objectives of controlling pollutants is not being met.
6. Operator shall implement these and any other BMP's that may be required to meet the general permit requirements.
7. Site is not in karst area or pollution or remediation site.
8. Silt fence to be installed downhill from any grading activity.
9. If tracking onto adjacent streets occurs a street sweeper shall be used to clean streets within 8 hours or as directed by the engineer.
10. Dust control may be necessary during rough grading. No grading can take place if wind speed exceeds 25 mph.
11. Solid waste shall be collected and disposed of properly and must comply with MPCA disposal requirements.
12. Hazardous materials shall be stored properly to prevent spills and vandalism.
13. No engine degreasing is allowed on site. External washing of vehicles shall be limited to a defined area (bone yard) on site.
14. Permittee(s) shall adhere to all SWPPP specifications on the plan and other MPCA permit requirements.

EROSION PREVENTION PRACTICES:

1. The permittee(s) must plan for and implement appropriate construction phasing, vegetative buffer strips, horizontal slope grading, and other construction practices that minimize erosion, so that the inspection and maintenance requirements are complied with. The location of areas not to be disturbed must be delineated (e.g. with flags, stakes, signs, silt fence, etc.) on the development site before work begins.
2. All exposed soil areas must be stabilized as soon as practical, but in no case later than 7 days after the construction area has temporarily or permanently ceased.
These areas include constructed stormwater management pond side slopes, and any exposed soil areas with a positive slope to a stormwater conveyance system, such as a curb and gutter system, storm sewer inlet, temporary or permanent drainage ditch or other natural or man made systems that discharge to a surface water.
3. The normal wetted perimeter of any temporary or permanent drainage ditch that drains water from a construction site, or diverts water around a site, must be stabilized within 200 lineal feet from the property edge, or from the point of discharge to any surface water. Stabilization must be completed within 24 hours of connecting to a surface water.
4. Pipe outlets must be provided with temporary or permanent energy dissipation within 24 hours of connection to a surface water.
5. All disturbed areas, except roadways, building areas, parking areas, islands and sidewalk, shall be restored with minimum 4 inches topsoil, seeded and mulched within 7 days of completion of site grading. Seeding shall be in accordance with MnDOT Specification 2575. Where side slopes exceed or equal 1:3 and running slope is greater than 1:50, a polypropylene netting or wood fiber blanket shall be provided and staked over the mulched area. Seed and mulch types and applications rates are per plan and specification.
6. Refer to restoration plan for areas to be seeded or sodded for erosion control.

DEWATERING AND BASIN DRAINING:

1. Dewatering or basin draining (e.g. pumped discharges, trench/ditch cuts for drainage) related to the construction activity that may have turbid or sediment laden discharge water must be discharged to a temporary or permanent sedimentation basin on the project site whenever possible. If the water cannot be discharged to a sedimentation basin prior to entering the surface water, it must be treated with the appropriate BMP's, such that the discharge does not adversely affect the receiving water or downstream landowners. The permittee(s) must ensure that discharge points are adequately protected from erosion and scour. The discharge must be dispersed over natural rock rip rap, sand bags, plastic sheeting or other accepted energy dissipation measures. Adequate sedimentation control measures are required for discharge water that contains suspended solids.
2. All water from dewatering or basin draining activities must be discharged in a manner that does not cause nuisance conditions, erosion in receiving channels or on downslope properties, or inundation in wetlands causing significant adverse impact to the wetland.

SEDIMENT CONTROL PRACTICES:

1. Sediment control practices must minimize sediment from entering surface waters, including curb and gutter systems and storm sewer inlets.
 - a. Temporary or permanent drainage ditches and sediment basins that are designed as part of a treatment system (e.g. ditches with rock check dams) require sediment control practices only as appropriate for site conditions.
 - b. If the down gradient treatment system is overloaded, additional upgradient sediment control practices must be installed to eliminate the overloading, and the SWPPP must be amended to identify these additional practices.
 - c. In order to maintain sheet flow and minimize rills and/or gullies, there shall be no unbroken slope length of greater than 75 feet for slopes with a grade of 1:3 or steeper.
2. Sediment control practices must be established on all down gradient perimeters before any upgradient land disturbing activities begin. These practices shall remain in place until final stabilization has been established.
3. The timing of the installation of sediment control practices may be adjusted to accommodate short-term activities such as clearing or grubbing, or passage of vehicles. Any short-term activity must be completed as quickly as possible and the sediment control practices must be installed immediately after the activity is completed. However, sediment control practices must be installed before the next precipitation event even if the activity is not complete.
4. All storm drain inlets must be protected by appropriate BMP's during construction until all sources with potential for discharging to the inlet have been stabilized.
5. Temporary soil stockpiles must have silt fence or other effective sediment controls, and cannot be placed in surface waters, including stormwater conveyances such as curb and gutter systems, or conduits and ditches.
6. Stockpile areas which remain on the site for more than seven days shall be seeded, mulched, and surrounded by silt fence.
7. Vehicle tracking of sediment from the construction site must be minimized by BMP's such as stone pads, concrete or steel wash racks, or equivalent systems. Street sweeping must be used if such BMPs are not adequate to prevent sediment from being tracked onto the street.
8. The permittee must install temporary sedimentation basins as required.

INSPECTIONS AND MAINTENANCE:

1. The permittee(s) (either the owner or operator, whoever is identified in the SWPPP) must routinely inspect the construction site once every seven (7) days during active construction and within 24 hours after a rainfall event greater than 0.5-inches in 24 hours. Following an inspection that occurs within 24 hours after a rainfall event, the next inspection must be conducted within 7 days.
2. All inspections and maintenance conducted during construction must be recorded in writing and these records must be retained with the SWPPP. Records of each inspection and maintenance activity shall include:
 - a. Date and time of inspections;
 - b. Name of persons conducting inspections;
 - c. Accurate findings of inspections, including the specific location where corrective actions are needed;
 - d. Corrective actions taken (including dates, times, and party completing maintenance activities);
 - e. Date of all rainfall events greater than ½ inches in 24 hours, and the amount of rainfall for each event. Permittee(s) must obtain rainfall amounts by either a properly maintained rain gauge installed onsite, a weather station that is within one (1) mile of your location, or a weather reporting system that provides site specific rainfall data from radar summaries;
 - f. If permittee(s) observe a discharge (i.e., color, odor, settled or suspended solids, oil sheen, and other obvious indicators of pollutant(s));
 - g. Any amendments to the SWPPP proposed as a result of the inspection must be documented as required in Section 6 of the general permit within seven (7) calendar days.
3. Where parts of the construction site have undergone final stabilization, but work remains on other parts of the site, inspections of the stabilized areas may be reduced to once per month. Where work has been suspended due to frozen ground conditions, the required inspections and maintenance must take place within 24 hours after runoff occurs at the site or 24 hours prior to resuming construction, whichever occurs first.
4. All erosion prevention and sediment control BMP's must be inspected to ensure integrity and effectiveness. All nonfunctional BMP's must be repaired, replaced, or supplemented with functional BMP's. The permittee(s) must investigate and comply with the following inspection and maintenance requirements:
 - a. All silt fence must be repaired, replaced, or supplemented when they become nonfunctional or the sediment reaches ½ of the height of the fence. These repairs must be made within 24 hours of discovery, or as soon as field conditions allow access.
 - b. Temporary and permanent sedimentation basins must be drained and the sediment removed when the depth of sediment collected in the basin reaches ½ the storage volume. Drainage and removal must be completed within 72 hours of discovery, or as soon as field conditions allow access.
 - c. Surface waters, including drainage ditches and conveyance systems, must be inspected for evidence of sediment being deposited by erosion. The permittee(s) must remove all deltas and sediment deposited in surface waters, including drainage ways, catch basins, and other drainage systems, and restabilize the areas where sediment removal results in exposed soil. The removal and stabilization must take place within seven (7) days of discovery unless precluded by legal, regulatory, or physical access constraints. The permittee shall use all reasonable efforts to obtain access. If precluded, removal and stabilization must take place within seven (7) calendar days of obtaining access. The permittee is responsible for contacting all local, regional, state and federal authorities and receiving any applicable permits, prior to conducting any work.
 - d. Construction site vehicle exit locations must be inspected for evidence of off-site sediment tracking onto paved surfaces. Tracked sediment must be removed from all paved surfaces within 3 hours after notification by the City that sweeping is required.
 - e. The permittee(s) are responsible for the operation and maintenance of temporary and permanent water quality management BMP's as well as all erosion prevention and sediment control BMP's, for the duration of the construction work at the site. The permittee(s) are responsible until another permittee has assumed control over all areas of the site that have not been finally stabilized or the site has undergone final stabilization, and a NOT has been submitted to the MPCA.
 - e. If sediment escapes the construction site, off-site accumulations of sediment must be removed in a manner and at a frequency sufficient to minimize off-site impacts (e.g. fugitive sediment in streets could be washed into storm sewers by the next rain and/or pose a safety hazard to users of public streets).
5. All infiltration areas must be inspected to ensure that no sediment from ongoing construction activities is reaching the infiltration area and these areas are protected from compaction due to construction equipment driving across the infiltration area.
6. Storm sewer pipes and structures to be inspected and cleaned out.

DATE	REVISION

I hereby certify that this plan, specification, or report was prepared by me or under my direct supervision and that I am a duly Licensed Professional Engineer Under the laws of the State of Minnesota

Joe Feriancek
JOE FERIANCEK
Date 1/23/24 Lic. No. 57095

DESIGNED BY:	JJF	DATE:	12/15/23
DRAWN BY:	JJF	FILE:	24-02
CHECKED BY:	BRW		

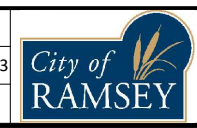

CITY OF RAMSEY
7550 SUNWOOD DRIVE
RAMSEY, MN 55303
(763) 427-1410 FAX (763) 433-9898

SWPPP

HALLS DOVER ACRES STREET RECONSTRUCTIONS
CITY PROJECT NO. 24-02
CITY OF RAMSEY, MINNESOTA

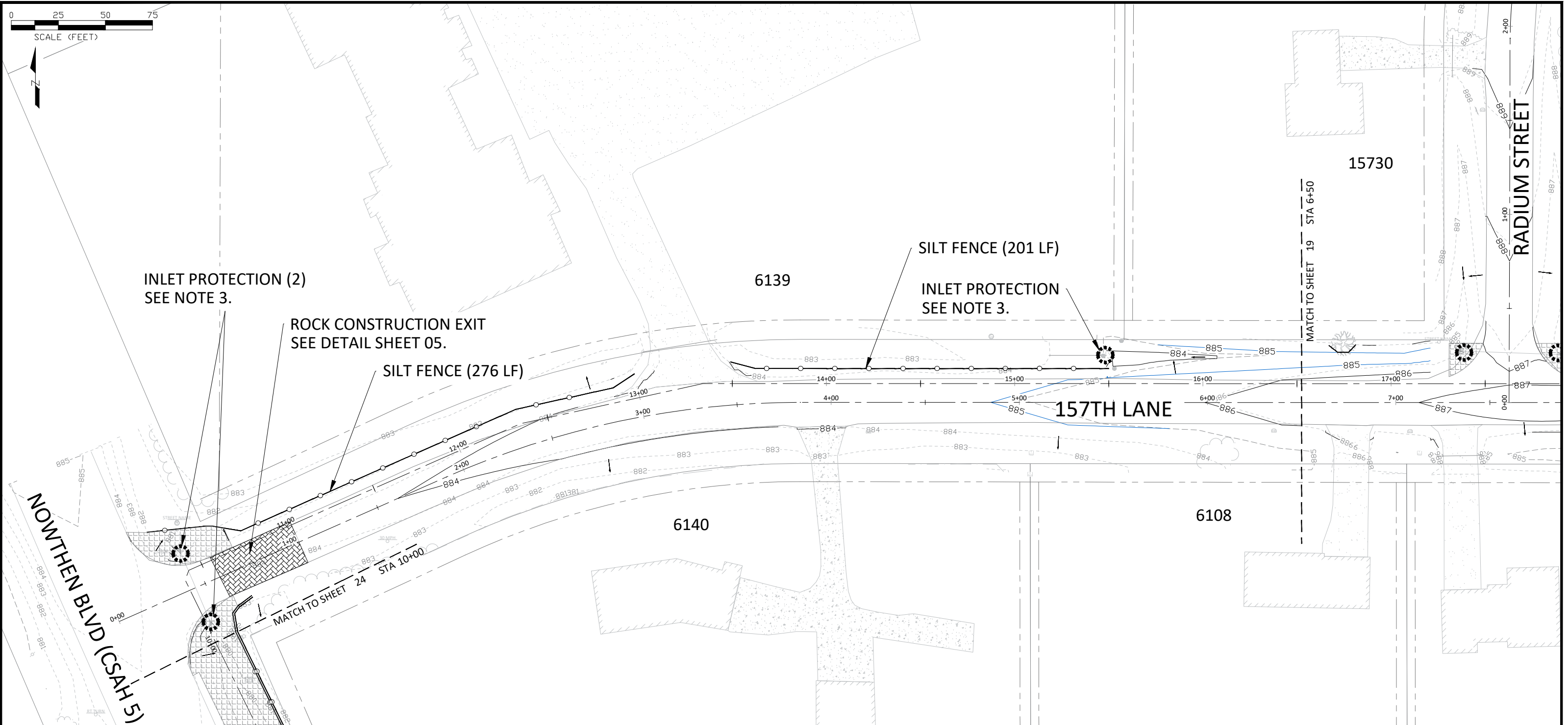
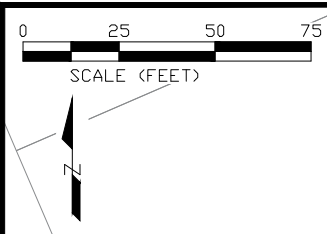

LEGEND

	PR. MAJOR CONTOUR		ROCK CONSTRUCTION EXIT
	PR. MINOR CONTOUR		EROSION CONTROL BLANKET
	PR. DRAINAGE ARROW		REMOVE TREE (INDIVIDUAL)
	EX. MAJOR CONTOUR		INLET PROTECTION
	EX. MINOR CONTOUR		TREE SAVE FENCE
	CONSTRUCTION LIMIT		EROSION CONTROL LOG
	DRAINAGE & UTILITY EASEMENT		SILT FENCE
	RIGHT OF WAY LINE		
	SECTION LINE		

NOTE:

- SILT FENCE AND TREE SAVE FENCING MUST BE INSTALLED BEFORE ANY OTHER ACTIVITIES ON-SITE. WHERE USED FOR LONGITUDINAL PROTECTION, EROSION CONTROL LOG MUST BE INSTALLED PRIOR TO ANY REMOVAL ACTIVITIES.
- STORM SEWER INLET PROTECTION IS TO BE INSTALLED IMMEDIATELY FOLLOWING CASTING INSTALLATION. FOR EXISTING INLETS, MUST BE INSTALLED PRIOR TO ANY REMOVAL ACTIVITIES. INLET PROTECTION MUST BE MAINTAINED UNTIL BITUMINOUS WEAR COURSE IS IN-PLACE.
- CULVERT INLET PROTECTION INCLUDES SURROUNDING CULVERT WITH EROSION CONTROL LOG TO PREVENT SEDIMENT FROM ENTERING CULVERT. THIS WILL BE PAID FOR PER LINEAL FOOT. FOR NEW CULVERTS EROSION CONTROL LOG MUST BE INSTALLED IMMEDIATELY FOLLOWING GRADING ACTIVITIES. EROSION CONTROL LOG MUST BE MAINTAINED UNTIL VEGETATION IS ESTABLISHED.

EROSION CONTROL SUMMARY: 157TH LN. STA. 0+00 TO 6+50

SILT FENCE	477 LF
TREE SAVE FENCE	0 LF
ERO. CONTROL LOG	75 LF
INLET PROTECTION	0 EA
ERO. BLANKET CAT. 20	89 SY
CONSTRUCTION EXIT	1 EA
PROJECT TOTAL	
SILT FENCE	2921 LF
TREE SAVE FENCE	20 LF
ERO. CONTROL LOG	575 LF
INLET PROTECTION	2 EA
ERO. BLANKET CAT. 20	2234 SY
CONSTRUCTION EXIT	4 EA

DATE	REVISION

I hereby certify that this plan, specification, or report was prepared by me or under my direct supervision and that I am a duly Licensed Professional Engineer under the laws of the State of Minnesota.

Joe Feriancek
 JOE FERIANCEK
 Date: 1/23/24 Lic. No. 57095

DESIGNED BY:	JJF
DRAWN BY:	JJF
CHECKED BY:	BRW
DATE:	12/15/23
FILE:	24-02

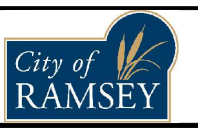

CITY OF RAMSEY
 7550 SUNWOOD DRIVE
 RAMSEY, MN 55303
 (763) 427-1410 FAX (763) 433-9898

EROSION CONTROL & GRADING

HALLS DOVER ACRES STREET RECONSTRUCTIONS
 CITY PROJECT NO. 24-02
 CITY OF RAMSEY, MINNESOTA

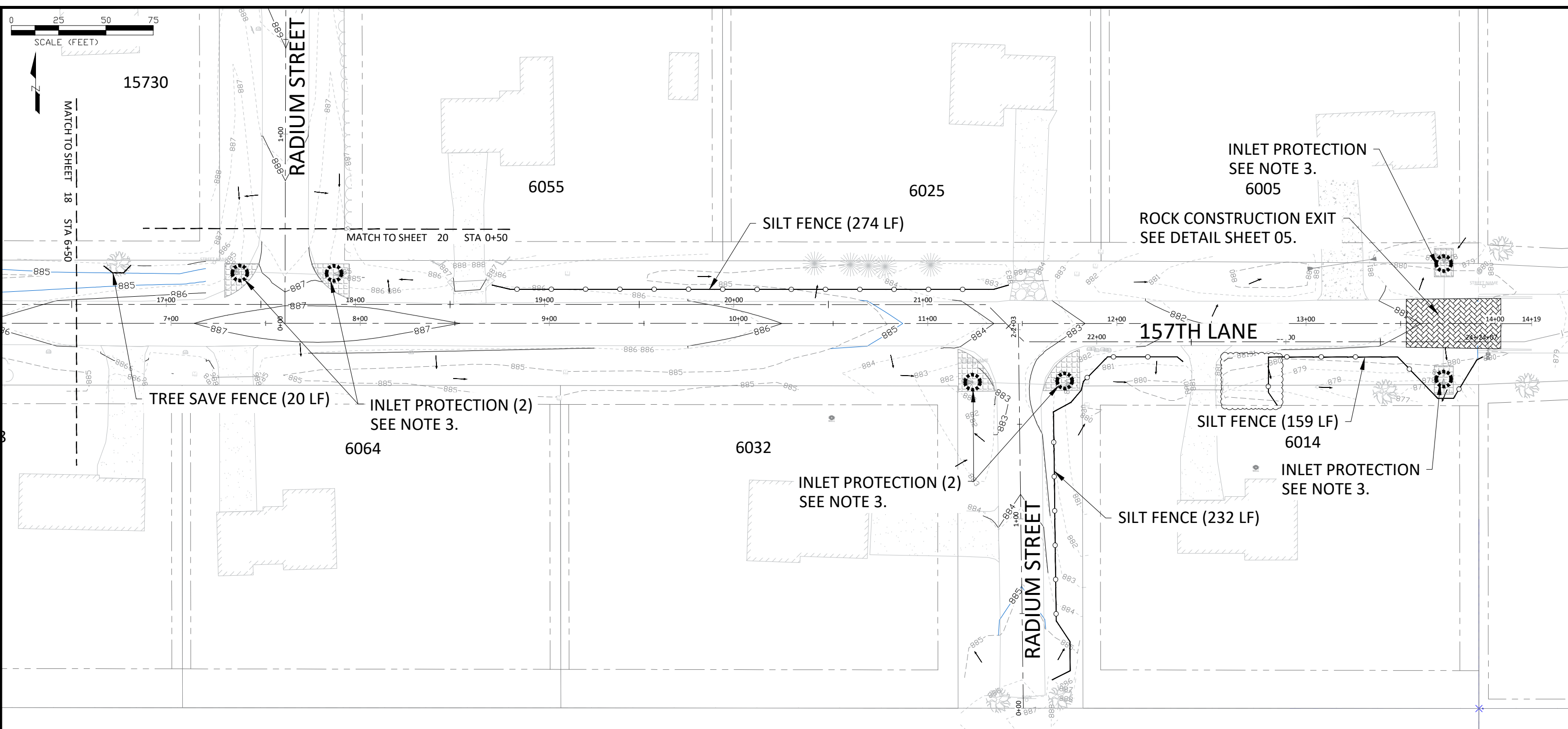

LEGEND

	PR. MAJOR CONTOUR		ROCK CONSTRUCTION EXIT
	PR. MINOR CONTOUR		EROSION CONTROL BLANKET
	PR. DRAINAGE ARROW		RANDOM RIP RAP CLASS III
	EX. MAJOR CONTOUR		REMOVE TREE (AREA)
	EX. MINOR CONTOUR		REMOVE TREE (INDIVIDUAL)
	CONSTRUCTION LIMIT		INLET PROTECTION
	DRAINAGE & UTILITY EASEMENT		TREE SAVE FENCE
	RIGHT OF WAY LINE		EROSION CONTROL LOG
	SECTION LINE		SILT FENCE

NOTE:

- SILT FENCE AND TREE SAVE FENCING MUST BE INSTALLED BEFORE ANY OTHER ACTIVITIES ON-SITE. WHERE USED FOR LONGITUDINAL PROTECTION, EROSION CONTROL LOG MUST BE INSTALLED PRIOR TO ANY REMOVAL ACTIVITIES.
- STORM SEWER INLET PROTECTION IS TO BE INSTALLED IMMEDIATELY FOLLOWING CASTING INSTALLATION. FOR EXISTING INLETS, MUST BE INSTALLED PRIOR TO ANY REMOVAL ACTIVITIES. INLET PROTECTION MUST BE MAINTAINED UNTIL BITUMINOUS WEAR COURSE IS IN-PLACE.
- CULVERT INLET PROTECTION INCLUDES SURROUNDING CULVERT WITH EROSION CONTROL LOG TO PREVENT SEDIMENT FROM ENTERING CULVERT. THIS WILL BE PAID FOR PER LINEAL FOOT. FOR NEW CULVERTS EROSION CONTROL LOG MUST BE INSTALLED IMMEDIATELY FOLLOWING GRADING ACTIVITIES. EROSION CONTROL LOG MUST BE MAINTAINED UNTIL VEGETATION IS ESTABLISHED.

EROSION CONTROL SUMMARY: 157TH LN. STA. 6+50 TO END & RADIUM ST. STUB

SILT FENCE	665 LF
TREE SAVE FENCE	20 LF
ERO. CONTROL LOG	150 LF
INLET PROTECTION	0 EA
ERO. BLANKET CAT. 20	145 SY
CONSTRUCTION EXIT	1 EA

PROJECT TOTAL	
SILT FENCE	2921 LF
TREE SAVE FENCE	20 LF
ERO. CONTROL LOG	575 LF
INLET PROTECTION	2 EA
ERO. BLANKET CAT. 20	2234 SY
CONSTRUCTION EXIT	4 EA

DATE	REVISION
3/28/24	ADD 1" WATER SERVICE - 6014 157TH LN.

I hereby certify that this plan, specification, or report was prepared by me or under my direct supervision and that I am a duly Licensed Professional Engineer under the laws of the State of Minnesota.

Joe Feriancek
 JOE FERIANCEK
 Date 4/23/24 Lic. No. 57095

DESIGNED BY:	JJF
DRAWN BY:	JJF
CHECKED BY:	BRW
DATE:	12/15/23
FILE:	24-02

CITY OF RAMSEY
 7550 SUNWOOD DRIVE
 RAMSEY, MN 55303
 (763) 427-1410 FAX (763) 433-9898

EROSION CONTROL & GRADING

HALLS DOVER ACRES STREET RECONSTRUCTIONS
 CITY PROJECT NO. 24-02
 CITY OF RAMSEY, MINNESOTA

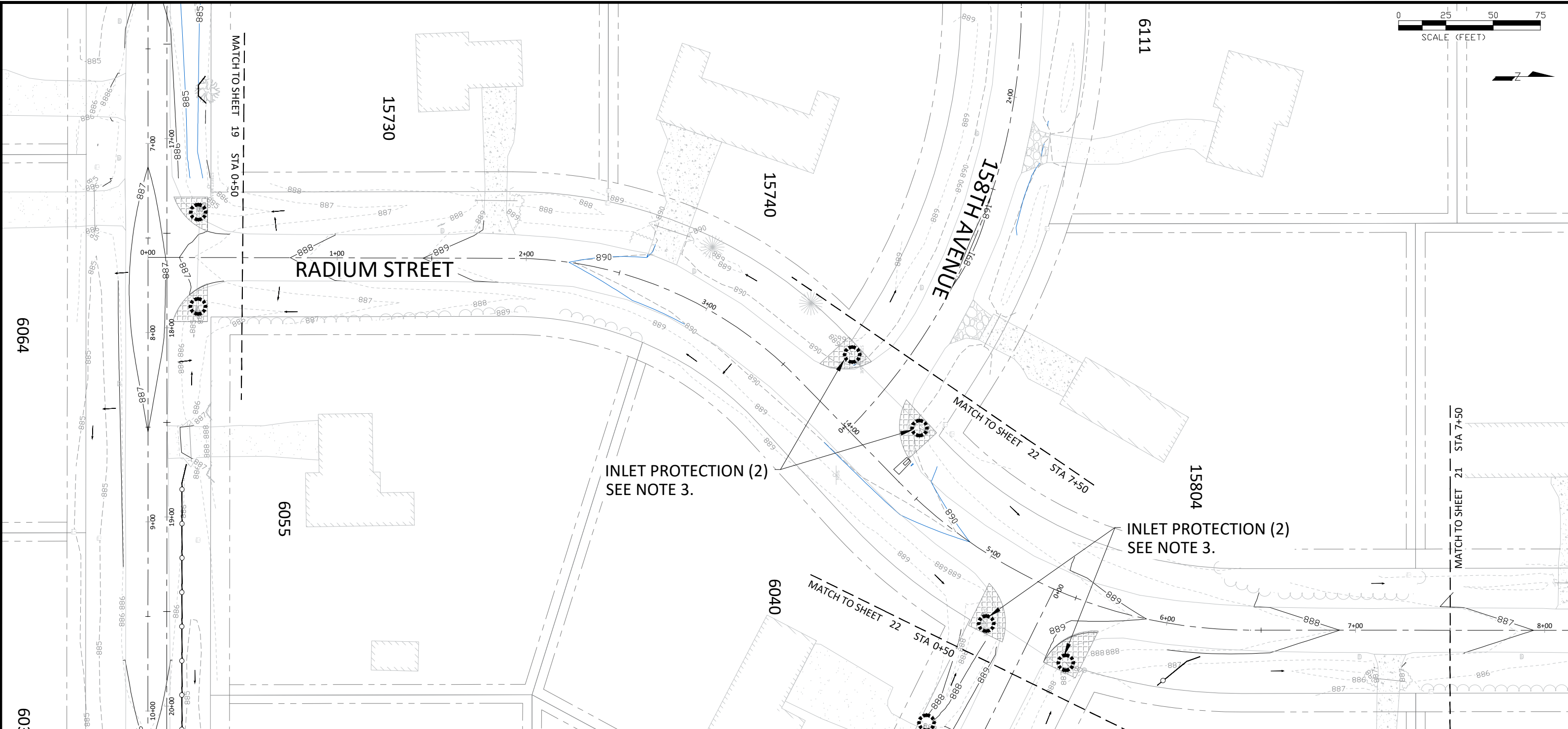
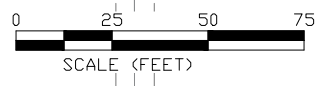

LEGEND

	PR. MAJOR CONTOUR		ROCK CONSTRUCTION EXIT
	PR. MINOR CONTOUR		EROSION CONTROL BLANKET
	PR. DRAINAGE ARROW		RANDOM RIP RAP CLASS III
	EX. MAJOR CONTOUR		REMOVE TREE (AREA)
	EX. MINOR CONTOUR		REMOVE TREE (INDIVIDUAL)
	CONSTRUCTION LIMIT		INLET PROTECTION
	DRAINAGE & UTILITY EASEMENT		TREE SAVE FENCE
	RIGHT OF WAY LINE		EROSION CONTROL LOG
	SECTION LINE		SILT FENCE

NOTE:

- SILT FENCE AND TREE SAVE FENCING MUST BE INSTALLED BEFORE ANY OTHER ACTIVITIES ON-SITE. WHERE USED FOR LONGITUDINAL PROTECTION, EROSION CONTROL LOG MUST BE INSTALLED PRIOR TO ANY REMOVAL ACTIVITIES.
- STORM SEWER INLET PROTECTION IS TO BE INSTALLED IMMEDIATELY FOLLOWING CASTING INSTALLATION. FOR EXISTING INLETS, MUST BE INSTALLED PRIOR TO ANY REMOVAL ACTIVITIES. INLET PROTECTION MUST BE MAINTAINED UNTIL BITUMINOUS WEAR COURSE IS IN-PLACE.
- CULVERT INLET PROTECTION INCLUDES SURROUNDING CULVERT WITH EROSION CONTROL LOG TO PREVENT SEDIMENT FROM ENTERING CULVERT. THIS WILL BE PAID FOR PER LINEAL FOOT. FOR NEW CULVERTS EROSION CONTROL LOG MUST BE INSTALLED IMMEDIATELY FOLLOWING GRADING ACTIVITIES. EROSION CONTROL LOG MUST BE MAINTAINED UNTIL VEGETATION IS ESTABLISHED.

EROSION CONTROL SUMMARY: RADIUM ST. STA. 0+50 TO 7+50

SILT FENCE	0 LF
TREE SAVE FENCE	0 LF
ERO. CONTROL LOG	100 LF
INLET PROTECTION	0 EA
ERO. BLANKET CAT. 20	142 SY
CONSTRUCTION EXIT	0 EA
PROJECT TOTAL	
SILT FENCE	2921 LF
TREE SAVE FENCE	20 LF
ERO. CONTROL LOG	2234 LF
INLET PROTECTION	2 EA
ERO. BLANKET CAT. 20	2234 SY
CONSTRUCTION EXIT	4 EA

DATE	REVISION

I hereby certify that this plan, specification, or report was prepared by me or under my direct supervision and that I am a duly Licensed Professional Engineer Under the laws of the State of Minnesota

Joe Feriancek
 JOE FERIANCEK
 Date 1/23/24 Lic. No. 57095

DESIGNED BY:	JJF
DRAWN BY:	JJF
CHECKED BY:	BRW
DATE:	12/15/23
FILE:	24-02

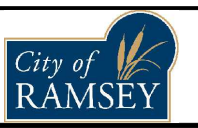

CITY OF RAMSEY
 7550 SUNWOOD DRIVE
 RAMSEY, MN 55303
 (763) 427-1410 FAX (763) 433-9898

EROSION CONTROL & GRADING

HALLS DOVER ACRES STREET RECONSTRUCTIONS
 CITY PROJECT NO. 24-02
 CITY OF RAMSEY, MINNESOTA

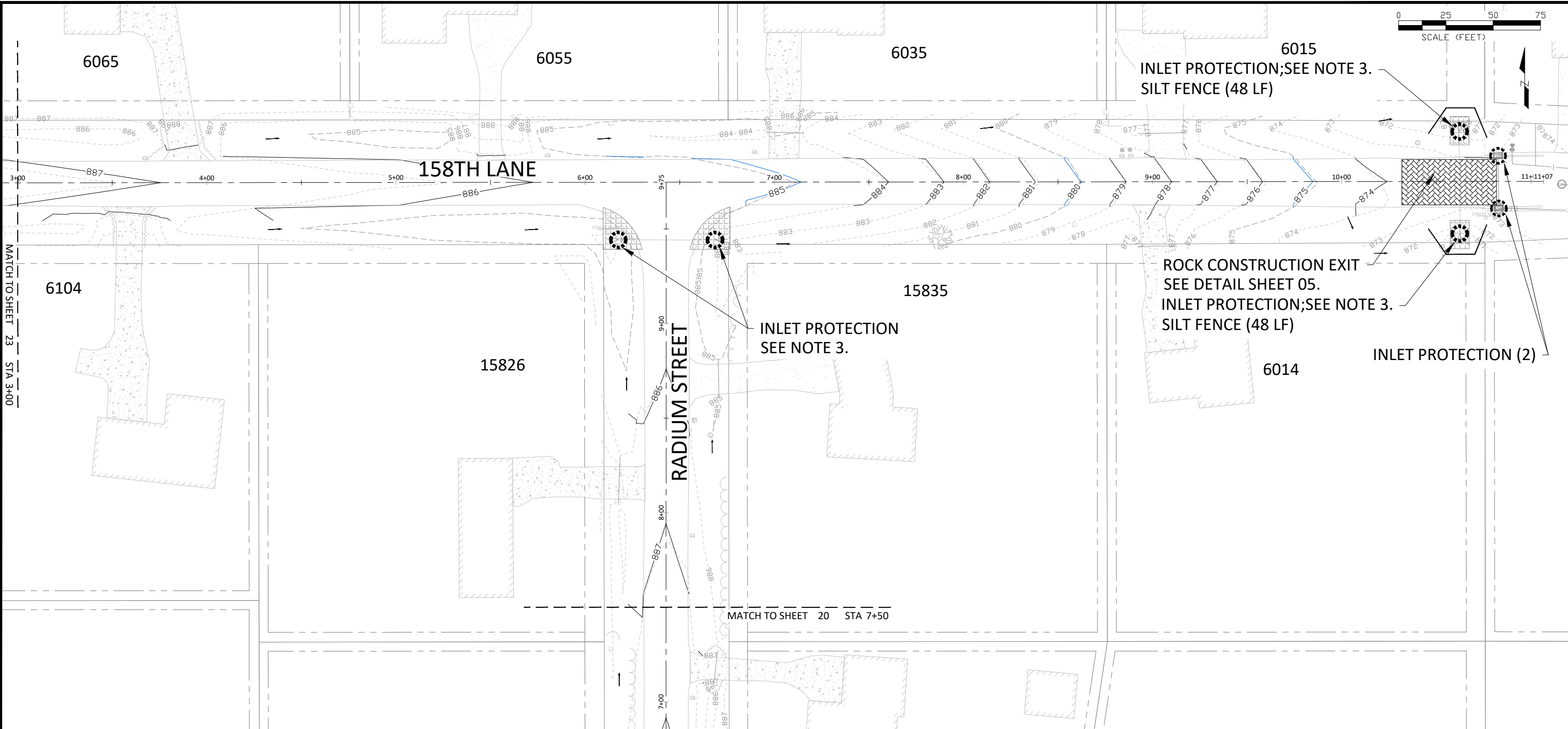
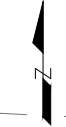
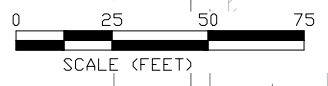

LEGEND

- PR. MAJOR CONTOUR
- PR. MINOR CONTOUR
- PR. DRAINAGE ARROW
- EX. MAJOR CONTOUR
- EX. MINOR CONTOUR
- CONSTRUCTION LIMIT
- DRAINAGE & UTILITY EASEMENT
- RIGHT OF WAY LINE
- SECTION LINE
- ROCK CONSTRUCTION EXIT
- EROSION CONTROL BLANKET
- RANDOM RIP RAP CLASS III
- REMOVE TREE (AREA)
- REMOVE TREE (INDIVIDUAL)
- INLET PROTECTION
- TREE SAVE FENCE
- EROSION CONTROL LOG
- SILT FENCE

NOTE:

1. SILT FENCE AND TREE SAVE FENCING MUST BE INSTALLED BEFORE ANY OTHER ACTIVITIES ON-SITE. WHERE USED FOR LONGITUDINAL PROTECTION, EROSION CONTROL LOG MUST BE INSTALLED PRIOR TO ANY REMOVAL ACTIVITIES.
2. STORM SEWER INLET PROTECTION IS TO BE INSTALLED IMMEDIATELY FOLLOWING CASTING INSTALLATION. FOR EXISTING INLETS, MUST BE INSTALLED PRIOR TO ANY REMOVAL ACTIVITIES. INLET PROTECTION MUST BE MAINTAINED UNTIL BITUMINOUS WEAR COURSE IS IN-PLACE.
3. CULVERT INLET PROTECTION INCLUDES SURROUNDING CULVERT WITH EROSION CONTROL LOG TO PREVENT SEDIMENT FROM ENTERING CULVERT. THIS WILL BE PAID FOR PER LINEAL FOOT. FOR NEW CULVERTS EROSION CONTROL LOG MUST BE INSTALLED IMMEDIATELY FOLLOWING GRADING ACTIVITIES. EROSION CONTROL LOG MUST BE MAINTAINED UNTIL VEGETATION IS ESTABLISHED.

EROSION CONTROL SUMMARY: RADIUM ST. STA. 7+50 TO END & 158TH LN. STA. 3+00 TO END

SILT FENCE	96 LF
TREE SAVE FENCE	0 LF
ERO. CONTROL LOG	100 LF
INLET PROTECTION	2 EA
ERO. BLANKET CAT. 20	103 SY
CONSTRUCTION EXIT	1 EA
PROJECT TOTAL	
SILT FENCE	2921 LF
TREE SAVE FENCE	20 LF
ERO. CONTROL LOG	575 LF
INLET PROTECTION	2 EA
ERO. BLANKET CAT. 20	2234 SY
CONSTRUCTION EXIT	4 EA

DATE	REVISION

I hereby certify that this plan, specification, or report was prepared by me or under my direct supervision and that I am a duly Licensed Professional Engineer Under the laws of the State of Minnesota

Joe Feriancek
 JOE FERIANCEK
 Date 1/23/24 Lic. No. 57095

DESIGNED BY:	JJF
DRAWN BY:	JJF
CHECKED BY:	BRW
DATE:	12/15/23
FILE:	24-02

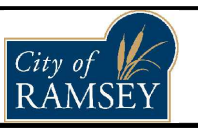

CITY OF RAMSEY
 7550 SUNWOOD DRIVE
 RAMSEY, MN 55303
 (763) 427-1410 FAX (763) 433-9898

EROSION CONTROL & GRADING

HALLS DOVER ACRES STREET RECONSTRUCTIONS
 CITY PROJECT NO. 24-02
 CITY OF RAMSEY, MINNESOTA

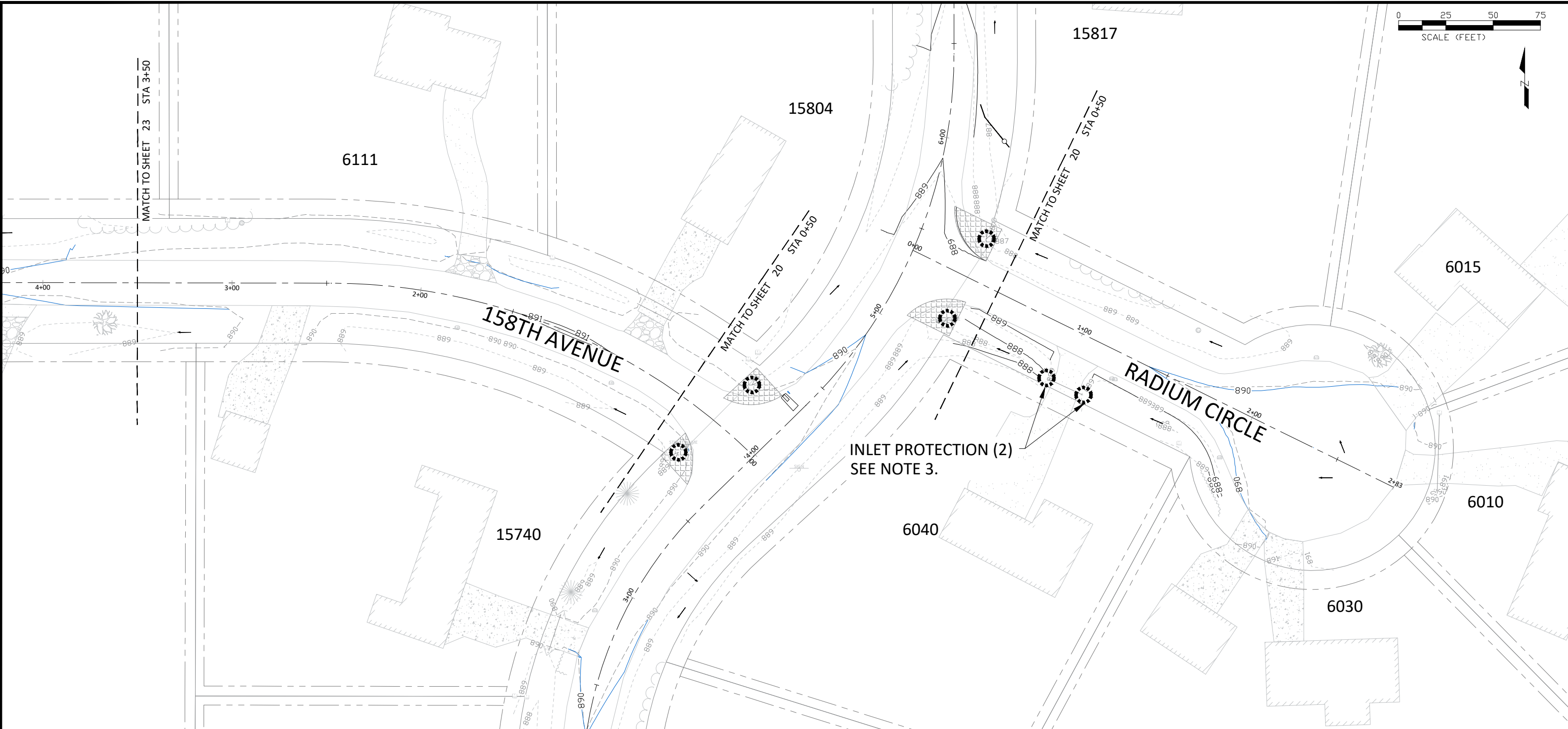
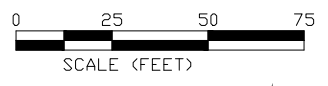

LEGEND

	PR. MAJOR CONTOUR		ROCK CONSTRUCTION EXIT
	PR. MINOR CONTOUR		EROSION CONTROL BLANKET
	PR. DRAINAGE ARROW		RANDOM RIP RAP CLASS III
	EX. MAJOR CONTOUR		REMOVE TREE (AREA)
	EX. MINOR CONTOUR		REMOVE TREE (INDIVIDUAL)
	CONSTRUCTION LIMIT		INLET PROTECTION
	DRAINAGE & UTILITY EASEMENT		TREE SAVE FENCE
	RIGHT OF WAY LINE		EROSION CONTROL LOG
	SECTION LINE		SILT FENCE

NOTE:

- SILT FENCE AND TREE SAVE FENCING MUST BE INSTALLED BEFORE ANY OTHER ACTIVITIES ON-SITE. WHERE USED FOR LONGITUDINAL PROTECTION, EROSION CONTROL LOG MUST BE INSTALLED PRIOR TO ANY REMOVAL ACTIVITIES.
- STORM SEWER INLET PROTECTION IS TO BE INSTALLED IMMEDIATELY FOLLOWING CASTING INSTALLATION. FOR EXISTING INLETS, MUST BE INSTALLED PRIOR TO ANY REMOVAL ACTIVITIES. INLET PROTECTION MUST BE MAINTAINED UNTIL BITUMINOUS WEAR COURSE IS IN-PLACE.
- CULVERT INLET PROTECTION INCLUDES SURROUNDING CULVERT WITH EROSION CONTROL LOG TO PREVENT SEDIMENT FROM ENTERING CULVERT. THIS WILL BE PAID FOR PER LINEAL FOOT. FOR NEW CULVERTS EROSION CONTROL LOG MUST BE INSTALLED IMMEDIATELY FOLLOWING GRADING ACTIVITIES. EROSION CONTROL LOG MUST BE MAINTAINED UNTIL VEGETATION IS ESTABLISHED.

EROSION CONTROL SUMMARY: RADIUM CIR. & 158TH AVE. STA. 0+50 TO 3+50

SILT FENCE	0 LF
TREE SAVE FENCE	0 LF
ERO. CONTROL LOG	50 LF
INLET PROTECTION	0 EA
ERO. BLANKET CAT. 20	0 SY
CONSTRUCTION EXIT	0 EA
PROJECT TOTAL	
SILT FENCE	2921 LF
TREE SAVE FENCE	20 LF
ERO. CONTROL LOG	575 LF
INLET PROTECTION	2 EA
ERO. BLANKET CAT. 20	2234 SY
CONSTRUCTION EXIT	4 EA

DATE	REVISION

I hereby certify that this plan, specification, or report was prepared by me or under my direct supervision and that I am a duly Licensed Professional Engineer Under the laws of the State of Minnesota

Joe Feriancek
 JOE FERIANCEK
 Date 1/23/24 Lic. No. 57095

DESIGNED BY:	JJF
DRAWN BY:	JJF
CHECKED BY:	BRW
DATE:	12/15/23
FILE:	24-02

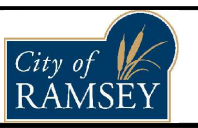

CITY OF RAMSEY
 7550 SUNWOOD DRIVE
 RAMSEY, MN 55303
 (763) 427-1410 FAX (763) 433-9898

EROSION CONTROL & GRADING

HALLS DOVER ACRES STREET RECONSTRUCTIONS
 CITY PROJECT NO. 24-02
 CITY OF RAMSEY, MINNESOTA

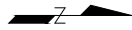

15810

PID 143225340021

INLET PROTECTION (2)
SEE NOTE 3.

15860

SODIUM STREET

INLET PROTECTION
SEE NOTE 3.

ROCK CONSTRUCTION EXIT
SEE DETAIL SHEET 05.

6139

15811

6134

6121

158TH LANE

MATCH TO SHEET 22 STA 3+50

MATCH TO SHEET 20 STA 3+00

LEGEND

	PR. MAJOR CONTOUR		ROCK CONSTRUCTION EXIT
	PR. MINOR CONTOUR		EROSION CONTROL BLANKET
	PR. DRAINAGE ARROW		RANDOM RIP RAP CLASS III
	EX. MAJOR CONTOUR		REMOVE TREE (AREA)
	EX. MINOR CONTOUR		REMOVE TREE (INDIVIDUAL)
	CONSTRUCTION LIMIT		INLET PROTECTION
	DRAINAGE & UTILITY EASEMENT		TREE SAVE FENCE
	RIGHT OF WAY LINE		EROSION CONTROL LOG
	SECTION LINE		SILT FENCE

NOTE:

- SILT FENCE AND TREE SAVE FENCING MUST BE INSTALLED BEFORE ANY OTHER ACTIVITIES ON-SITE. WHERE USED FOR LONGITUDINAL PROTECTION, EROSION CONTROL LOG MUST BE INSTALLED PRIOR TO ANY REMOVAL ACTIVITIES.
- STORM SEWER INLET PROTECTION IS TO BE INSTALLED IMMEDIATELY FOLLOWING CASTING INSTALLATION. FOR EXISTING INLETS, MUST BE INSTALLED PRIOR TO ANY REMOVAL ACTIVITIES. INLET PROTECTION MUST BE MAINTAINED UNTIL BITUMINOUS WEAR COURSE IS IN-PLACE.
- CULVERT INLET PROTECTION INCLUDES SURROUNDING CULVERT WITH EROSION CONTROL LOG TO PREVENT SEDIMENT FROM ENTERING CULVERT. THIS WILL BE PAID FOR PER LINEAL FOOT. FOR NEW CULVERTS EROSION CONTROL LOG MUST BE INSTALLED IMMEDIATELY FOLLOWING GRADING ACTIVITIES. EROSION CONTROL LOG MUST BE MAINTAINED UNTIL VEGETATION IS ESTABLISHED.

EROSION CONTROL SUMMARY: SODIUM ST. STA. 3+50 TO END & 158TH LN. STA. 0+50 TO 3+00

SILT FENCE	0 LF
TREE SAVE FENCE	0 LF
ERO. CONTROL LOG	75 LF
INLET PROTECTION	0 EA
ERO. BLANKET CAT. 20	18 SY
CONSTRUCTION EXIT	1 EA

PROJECT TOTAL	
SILT FENCE	2921 LF
TREE SAVE FENCE	20 LF
ERO. CONTROL LOG	575 LF
INLET PROTECTION	2 EA
ERO. BLANKET CAT. 20	2234 SY
CONSTRUCTION EXIT	4 EA

DATE	REVISION

I hereby certify that this plan, specification, or report was prepared by me or under my direct supervision and that I am a duly Licensed Professional Engineer Under the laws of the State of Minnesota

JOE FERIANCEK
 Date 1/23/24 Lic. No. 57095

DESIGNED BY:	JJF
DRAWN BY:	JJF
CHECKED BY:	BRW
DATE:	12/15/23
FILE:	24-02

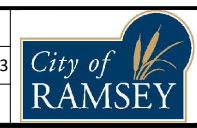

CITY OF RAMSEY
 7550 SUNWOOD DRIVE
 RAMSEY, MN 55303
 (763) 427-1410 FAX (763) 433-9898

EROSION CONTROL & GRADING

HALLS DOVER ACRES STREET RECONSTRUCTIONS
 CITY PROJECT NO. 24-02
 CITY OF RAMSEY, MINNESOTA

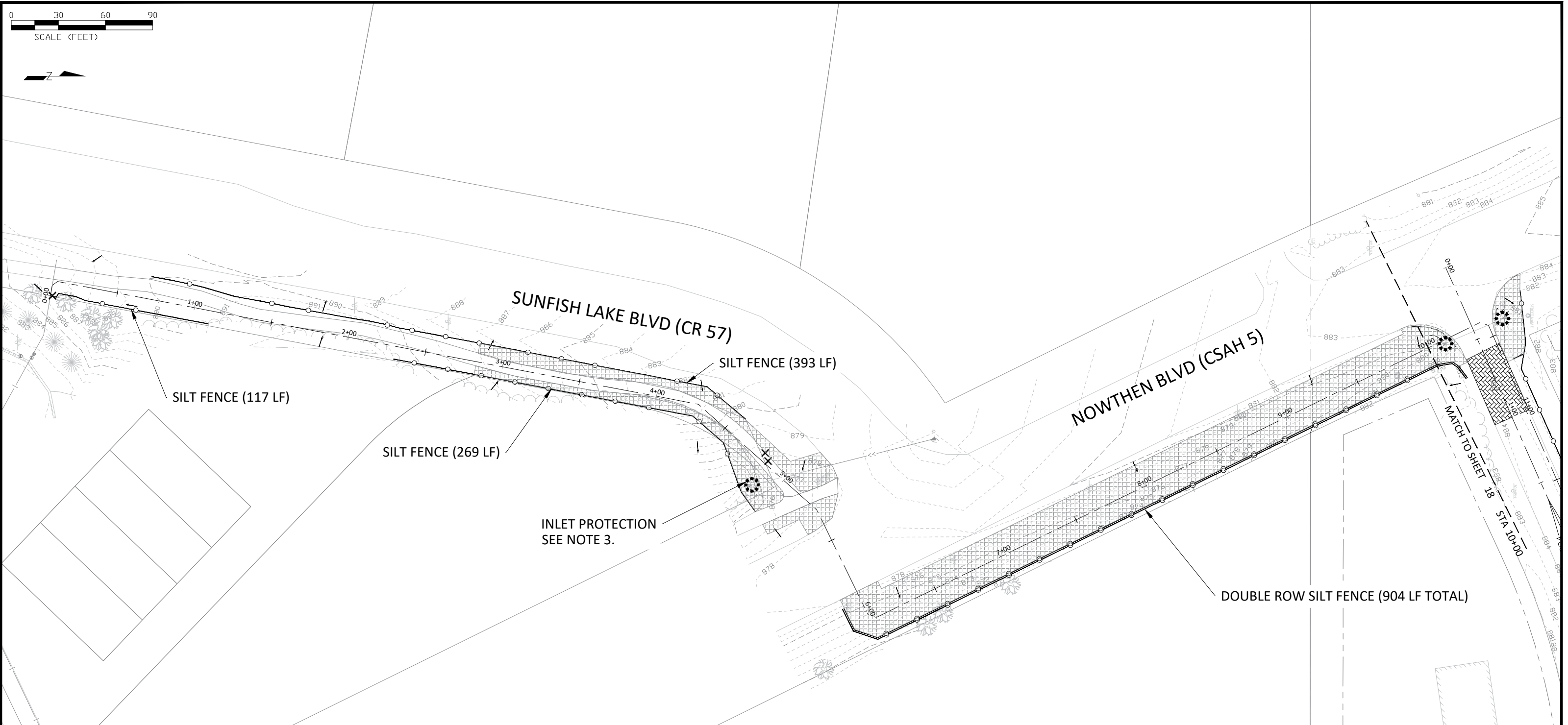

LEGEND

	PR. MAJOR CONTOUR		ROCK CONSTRUCTION EXIT
	PR. MINOR CONTOUR		EROSION CONTROL BLANKET
	PR. DRAINAGE ARROW		RANDOM RIP RAP CLASS III
	EX. MAJOR CONTOUR		REMOVE TREE (AREA)
	EX. MINOR CONTOUR		REMOVE TREE (INDIVIDUAL)
	CONSTRUCTION LIMIT		INLET PROTECTION
	DRAINAGE & UTILITY EASEMENT		TREE SAVE FENCE
	RIGHT OF WAY LINE		EROSION CONTROL LOG
	SECTION LINE		SILT FENCE

NOTE:

- SILT FENCE AND TREE SAVE FENCING MUST BE INSTALLED BEFORE ANY OTHER ACTIVITIES ON-SITE. WHERE USED FOR LONGITUDINAL PROTECTION, EROSION CONTROL LOG MUST BE INSTALLED PRIOR TO ANY REMOVAL ACTIVITIES.
- STORM SEWER INLET PROTECTION IS TO BE INSTALLED IMMEDIATELY FOLLOWING CASTING INSTALLATION. FOR EXISTING INLETS, MUST BE INSTALLED PRIOR TO ANY REMOVAL ACTIVITIES. INLET PROTECTION MUST BE MAINTAINED UNTIL BITUMINOUS WEAR COURSE IS IN-PLACE.
- CULVERT INLET PROTECTION INCLUDES SURROUNDING CULVERT WITH EROSION CONTROL LOG TO PREVENT SEDIMENT FROM ENTERING CULVERT. THIS WILL BE PAID FOR PER LINEAL FOOT. FOR NEW CULVERTS EROSION CONTROL LOG MUST BE INSTALLED IMMEDIATELY FOLLOWING GRADING ACTIVITIES. EROSION CONTROL LOG MUST BE MAINTAINED UNTIL VEGETATION IS ESTABLISHED.

EROSION CONTROL SUMMARY: WATERMAIN ROUTE STA. 0+00 TO 10+00

SILT FENCE	1683 LF
TREE SAVE FENCE	0 LF
ERO. CONTROL LOG	25 LF
INLET PROTECTION	0 EA
ERO. BLANKET CAT. 20	1737 SY
CONSTRUCTION EXIT	0 EA
PROJECT TOTAL	
SILT FENCE	2921 LF
TREE SAVE FENCE	20 LF
ERO. CONTROL LOG	575 LF
INLET PROTECTION	2 EA
ERO. BLANKET CAT. 20	2234 SY
CONSTRUCTION EXIT	4 EA

DATE	REVISION

I hereby certify that this plan, specification, or report was prepared by me or under my direct supervision and that I am a duly Licensed Professional Engineer Under the laws of the State of Minnesota

Joe Feriancek
 JOE FERIANCEK
 Date 1/23/24 Lic. No. 57095

DESIGNED BY:	JJF
DRAWN BY:	JJF
CHECKED BY:	BRW
DATE:	12/15/23
FILE:	24-02

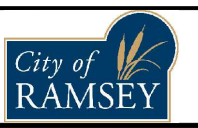

CITY OF RAMSEY
 7550 SUNWOOD DRIVE
 RAMSEY, MN 55303
 (763) 427-1410 FAX (763) 433-9898

EROSION CONTROL & GRADING

HALLS DOVER ACRES STREET RECONSTRUCTIONS
 CITY PROJECT NO. 24-02
 CITY OF RAMSEY, MINNESOTA

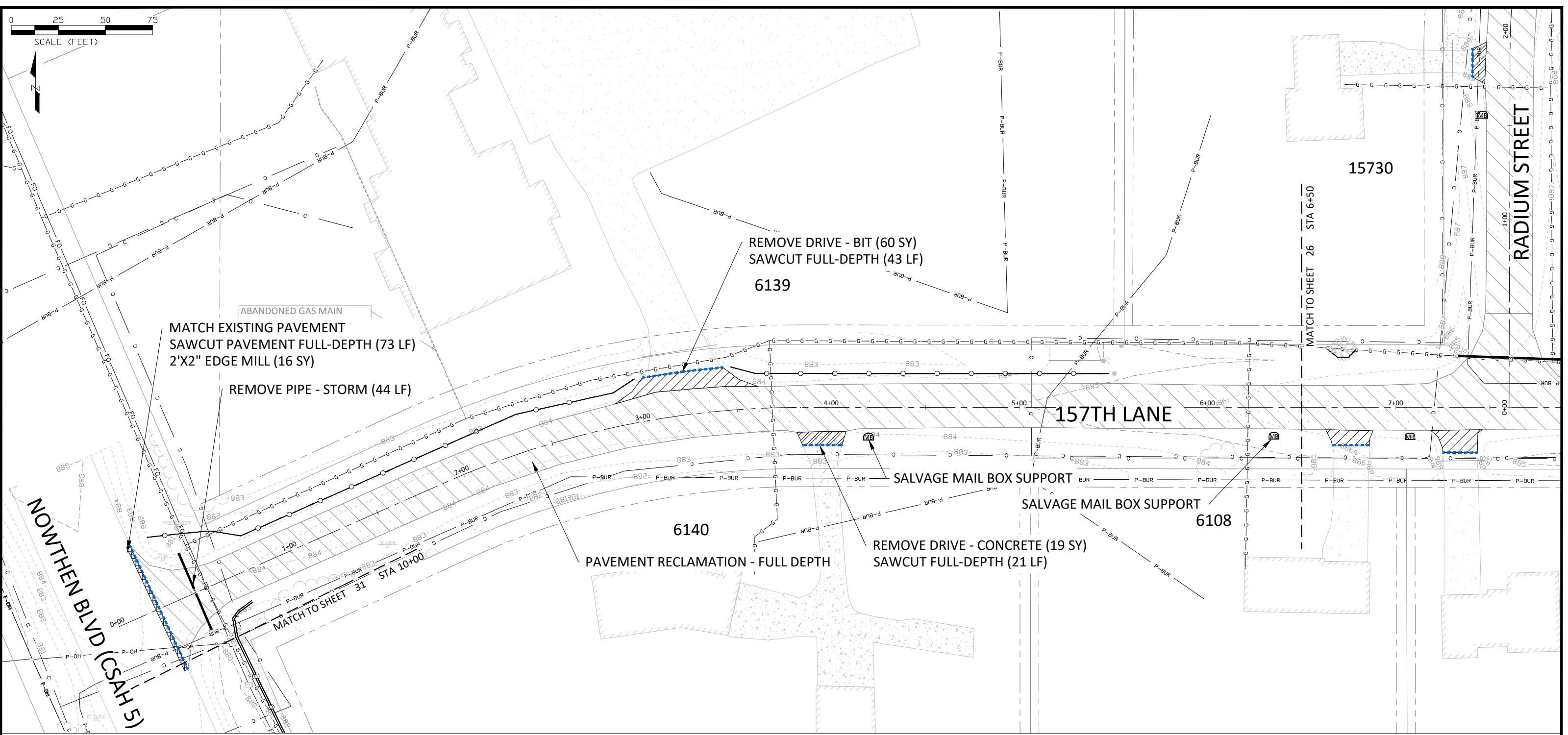
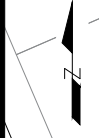
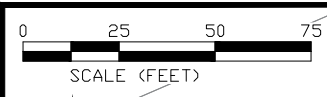

LEGEND

	RECLAMATION - FULL DEPTH		TREE SAVE FENCE
	REMOVE PAVEMENT - BITUMINOUS		SILT FENCE
	REMOVE PAVEMENT - CONCRETE		DRAINAGE & UTILITY EASEMENT LINE
	REMOVE SURFACE - GRAVEL		RIGHT OF WAY LINE
	MILL BITUMINOUS PAVEMENT - STREET TIE-IN		SECTION LINE
	REMOVE PIPE - STORM		TREE LINE
	REMOVE PIPE - WATERMAIN		OVERHEAD POWER LINE
	SAWCUT PAVEMENT - FULL DEPTH		BURIED POWER LINE
	CONSTRUCTION LIMITS		FIBER OPTIC LINE
	REMOVE TREE (INDIVIDUAL)		COMMUNICATION LINE
	SALVAGE MAIL BOX SUPPORT		GAS LINE

NOTE:

1. REMOVALS WILL BE MARKED IN THE FIELD BY CITY STAFF. ALL REMOVALS MUST BE SAWCUT.
2. REMOVALS CULVERT ENDS IS INCIDENTAL TO REMOVE PIPE -SEWER PAY ITEM.
3. PROTECT LANDSCAPING AND IRRIGATION. PROPERTY OWNERS ARE TO LOCATE AND MOVE IRRIGATION BEFORE CONSTRUCTION.

MAJOR CONTOUR
MINOR CONTOUR

REMOVALS SUMMARY: 157TH LN. STA. 0+00 TO 6+50

RECLAMATION FULL-DEPTH	1710 SY
REMOVE PAVEMENT - BITUMINOUS	60 SY
REMOVE PAVEMENT - CONCRETE	19 SY
REMOVE SURFACE - GRAVEL	0 SY
MILL BITUMINOUS PAVEMENT	16 SY
SAWCUT PAVEMENT - FULL DEPTH	137 LF
REMOVE PIPE - STORM	44 LF
REMOVE PIPE - WATERMAIN	0 LF
REMOVE TREE	0 EA
SALVAGE MAIL BOX SUPPORT	2 EA

PROJECT TOTAL

RECLAMATION FULL-DEPTH	14351 SY
REMOVE PAVEMENT - BITUMINOUS	1022 SY
REMOVE PAVEMENT - CONCRETE	205 SY
REMOVE SURFACE - GRAVEL	79 SY
MILL BITUMINOUS PAVEMENT	55 SY
SAWCUT PAVEMENT - FULL DEPTH	823 LF
REMOVE PIPE - STORM	540 LF
REMOVE PIPE - WATERMAIN	20 LF
REMOVE TREE	3 EA
SALVAGE MAIL BOX SUPPORT	28 EA

DATE	REVISION

I hereby certify that this plan, specification, or report was prepared by me or under my direct supervision and that I am a duly Licensed Professional Engineer Under the laws of the State of Minnesota

Joe Feriancek
JOE FERIANCEK
Date: 1/23/24 Lic. No. 57095

DESIGNED BY:	JJF
DRAWN BY:	JJF
CHECKED BY:	BRW

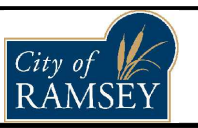

CITY OF RAMSEY
7550 SUNWOOD DRIVE
RAMSEY, MN 55303
(763) 427-1410 FAX (763) 433-9898

EXISTING CONDITIONS & REMOVALS

HALLS DOVER ACRES STREET RECONSTRUCTIONS
CITY PROJECT NO. 24-02
CITY OF RAMSEY, MINNESOTA

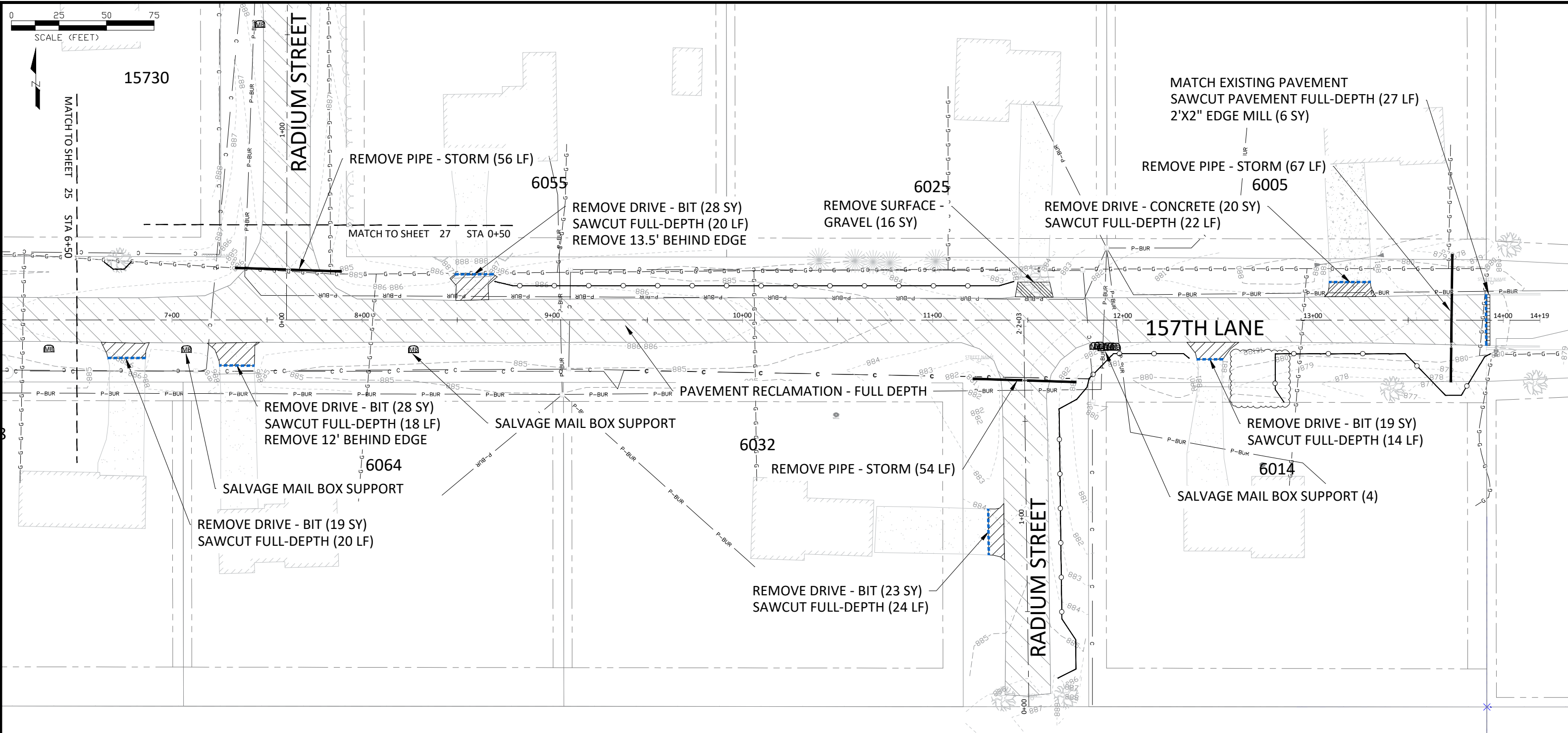

LEGEND

	RECLAMATION - FULL DEPTH		TREE SAVE FENCE
	REMOVE PAVEMENT - BITUMINOUS		SILT FENCE
	REMOVE PAVEMENT - CONCRETE		DRAINAGE & UTILITY EASEMENT LINE
	REMOVE SURFACE - GRAVEL		RIGHT OF WAY LINE
	MILL BITUMINOUS PAVEMENT - STREET TIE-IN		SECTION LINE
	REMOVE PIPE - STORM		TREE LINE
	REMOVE PIPE - WATERMAIN		OVERHEAD POWER LINE
	SAWCUT PAVEMENT - FULL DEPTH		BURIED POWER LINE
	CONSTRUCTION LIMITS		FIBER OPTIC LINE
	REMOVE TREE (INDIVIDUAL)		COMMUNICATION LINE
	SALVAGE MAIL BOX SUPPORT		GAS LINE

NOTE:

- REMOVALS WILL BE MARKED IN THE FIELD BY CITY STAFF. ALL REMOVALS MUST BE SAWCUT.
- REMOVALS CULVERT ENDS IS INCIDENTAL TO REMOVE PIPE - SEWER PAY ITEM.
- PROTECT LANDSCAPING AND IRRIGATION. PROPERTY OWNERS ARE TO LOCATE AND MOVE IRRIGATION BEFORE CONSTRUCTION.

REMOVALS SUMMARY: 157TH LN. STA. 6+50 TO END / RADIUM ST. STUB

RECLAMATION FULL-DEPTH	2626 SY
REMOVE PAVEMENT - BITUMINOUS	117 SY
REMOVE PAVEMENT - CONCRETE	20 SY
REMOVE SURFACE - GRAVEL	16 SY
MILL BITUMINOUS PAVEMENT	6 SY
SAWCUT PAVEMENT - FULL DEPTH	145 LF
REMOVE PIPE - STORM	177 LF
REMOVE PIPE - WATERMAIN	0 LF
REMOVE TREE	0 EA
SALVAGE MAIL BOX SUPPORT	6 EA

PROJECT TOTAL

RECLAMATION FULL-DEPTH	14351 SY
REMOVE PAVEMENT - BITUMINOUS	1022 SY
REMOVE PAVEMENT - CONCRETE	205 SY
REMOVE SURFACE - GRAVEL	79 SY
MILL BITUMINOUS PAVEMENT	55 SY
SAWCUT PAVEMENT - FULL DEPTH	823 LF
REMOVE PIPE - STORM	540 LF
REMOVE PIPE - WATERMAIN	20 LF
REMOVE TREE	3 EA
SALVAGE MAIL BOX SUPPORT	28 EA

DATE	REVISION
3/28/24	ADD 1" WATER SERVICE - 6014 157TH LN.

I hereby certify that this plan, specification, or report was prepared by me or under my direct supervision and that I am a duly Licensed Professional Engineer Under the laws of the State of Minnesota

Joe Feriancek
 JOE FERIANCEK
 Date: 4/23/24 Lic. No. 57095

DESIGNED BY:	JJF
DRAWN BY:	JJF
CHECKED BY:	BRW
DATE:	12/15/23
FILE:	24-02

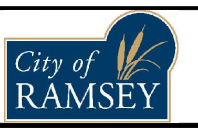

CITY OF RAMSEY
 7550 SUNWOOD DRIVE
 RAMSEY, MN 55303
 (763) 427-1410 FAX (763) 433-9898

EXISTING CONDITIONS & REMOVALS

HALLS DOVER ACRES STREET RECONSTRUCTIONS
 CITY PROJECT NO. 24-02
 CITY OF RAMSEY, MINNESOTA

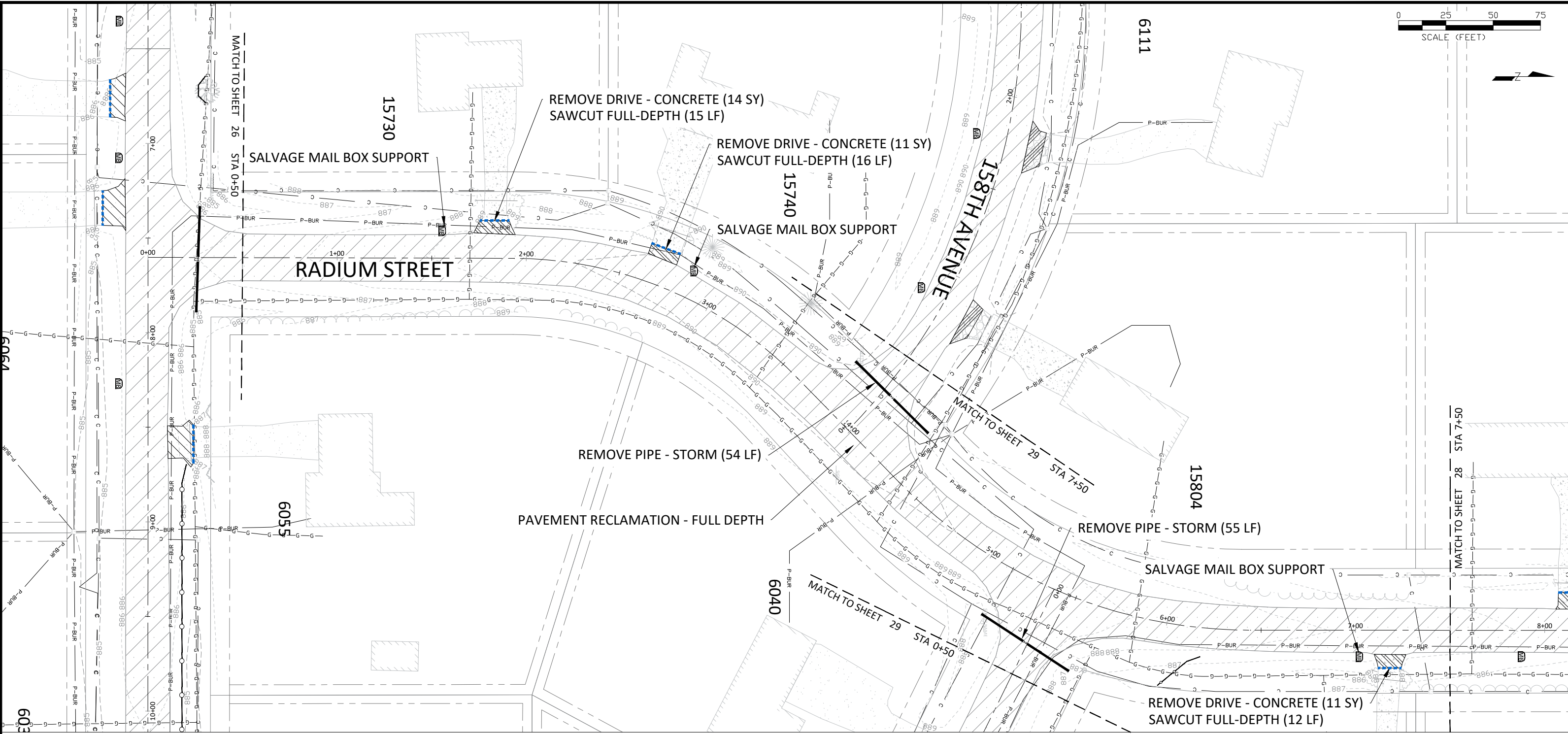
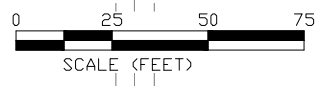

LEGEND

	RECLAMATION - FULL DEPTH		TREE SAVE FENCE
	REMOVE PAVEMENT - BITUMINOUS		SILT FENCE
	REMOVE PAVEMENT - CONCRETE		DRAINAGE & UTILITY EASEMENT LINE
	REMOVE SURFACE - GRAVEL		RIGHT OF WAY LINE
	MILL BITUMINOUS PAVEMENT - STREET TIE-IN		SECTION LINE
	REMOVE PIPE - STORM		TREE LINE
	REMOVE PIPE - WATERMAIN		OVERHEAD POWER LINE
	SAWCUT PAVEMENT - FULL DEPTH		BURIED POWER LINE
	CONSTRUCTION LIMITS		FIBER OPTIC LINE
	REMOVE TREE (INDIVIDUAL)		COMMUNICATION LINE
	SALVAGE MAIL BOX SUPPORT		GAS LINE

NOTE:

1. REMOVALS WILL BE MARKED IN THE FIELD BY CITY STAFF. ALL REMOVALS MUST BE SAWCUT.
2. REMOVALS CULVERT ENDS IS INCIDENTAL TO REMOVE PIPE - SEWER PAY ITEM.
3. PROTECT LANDSCAPING AND IRRIGATION. PROPERTY OWNERS ARE TO LOCATE AND MOVE IRRIGATION BEFORE CONSTRUCTION.

--- MAJOR CONTOUR
- - - MINOR CONTOUR

REMOVALS SUMMARY: RADIUM ST. STA. 0+50 TO 7+50

RECLAMATION FULL-DEPTH	2232 SY
REMOVE PAVEMENT - BITUMINOUS	0 SY
REMOVE PAVEMENT - CONCRETE	36 SY
REMOVE SURFACE - GRAVEL	0 SY
MILL BITUMINOUS PAVEMENT	0 SY
SAWCUT PAVEMENT - FULL DEPTH	43 LF
REMOVE PIPE - STORM	109 LF
REMOVE PIPE - WATERMAIN	0 LF
REMOVE TREE	0 EA
SALVAGE MAIL BOX SUPPORT	3 EA

PROJECT TOTAL

RECLAMATION FULL-DEPTH	14351 SY
REMOVE PAVEMENT - BITUMINOUS	1022 SY
REMOVE PAVEMENT - CONCRETE	205 SY
REMOVE SURFACE - GRAVEL	79 SY
MILL BITUMINOUS PAVEMENT	55 SY
SAWCUT PAVEMENT - FULL DEPTH	823 LF
REMOVE PIPE - STORM	540 LF
REMOVE PIPE - WATERMAIN	20 LF
REMOVE TREE	3 EA
SALVAGE MAIL BOX SUPPORT	28 EA

DATE	REVISION

I hereby certify that this plan, specification, or report was prepared by me or under my direct supervision and that I am a duly Licensed Professional Engineer Under the laws of the State of Minnesota

Joe Feriancek
JOE FERIANCEK
 Date: 1/23/24 Lic. No. 57095

DESIGNED BY:	JJF
DRAWN BY:	JJF
CHECKED BY:	BRW
DATE:	12/15/23
FILE:	24-02

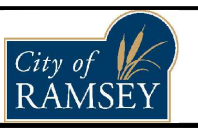

CITY OF RAMSEY
 7550 SUNWOOD DRIVE
 RAMSEY, MN 55303
 (763) 427-1410 FAX (763) 433-9898

EXISTING CONDITIONS & REMOVALS

HALLS DOVER ACRES STREET RECONSTRUCTIONS
 CITY PROJECT NO. 24-02
 CITY OF RAMSEY, MINNESOTA

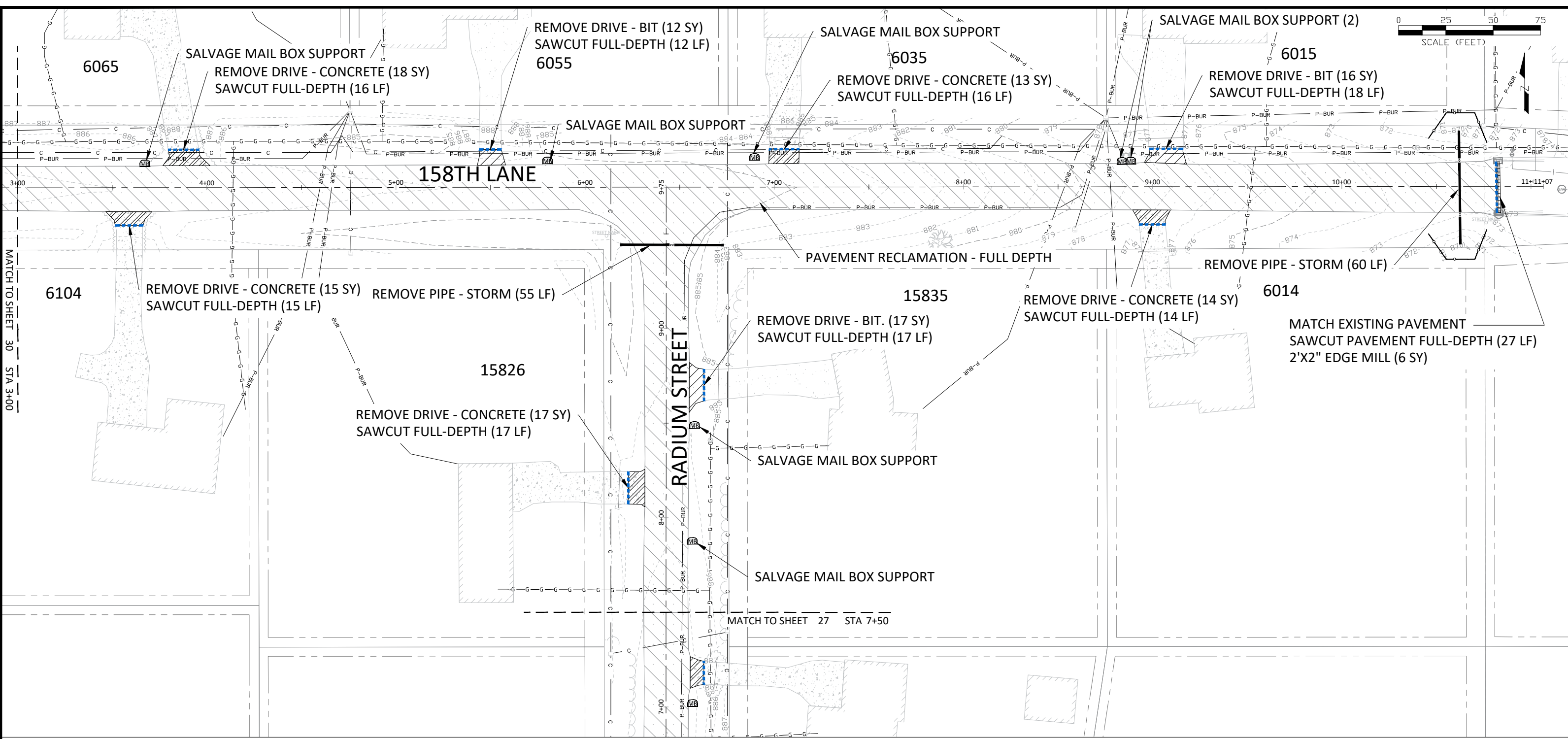
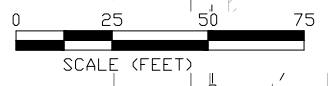

LEGEND	
	RECLAMATION - FULL DEPTH
	REMOVE PAVEMENT - BITUMINOUS
	REMOVE PAVEMENT - CONCRETE
	REMOVE SURFACE - GRAVEL
	MILL BITUMINOUS PAVEMENT - STREET TIE-IN
	REMOVE PIPE - STORM
	REMOVE PIPE - WATERMAIN
	SAWCUT PAVEMENT - FULL DEPTH
	CONSTRUCTION LIMITS
	REMOVE TREE (INDIVIDUAL)
	SALVAGE MAIL BOX SUPPORT
	TREE SAVE FENCE
	SILT FENCE
	DRAINAGE & UTILITY EASEMENT LINE
	RIGHT OF WAY LINE
	SECTION LINE
	TREE LINE
	OVERHEAD POWER LINE
	BURIED POWER LINE
	FIBER OPTIC LINE
	COMMUNICATION LINE
	GAS LINE
	MAJOR CONTOUR
	MINOR CONTOUR

NOTE:

- REMOVALS WILL BE MARKED IN THE FIELD BY CITY STAFF. ALL REMOVALS MUST BE SAWCUT.
- REMOVALS CULVERT ENDS IS INCIDENTAL TO REMOVE PIPE -SEWER PAY ITEM.
- PROTECT LANDSCAPING AND IRRIGATION. PROPERTY OWNERS ARE TO LOCATE AND MOVE IRRIGATION BEFORE CONSTRUCTION.

REMOVALS SUMMARY: RADIIUM ST. STA. 7+50 TO END / 158TH LN. STA. 3+00 TO END

RECLAMATION FULL-DEPTH	2742 SY
REMOVE PAVEMENT - BITUMINOUS	45 SY
REMOVE PAVEMENT - CONCRETE	77 SY
REMOVE SURFACE - GRAVEL	0 SY
MILL BITUMINOUS PAVEMENT	6 SY
SAWCUT PAVEMENT - FULL DEPTH	152 LF
REMOVE PIPE - STORM	115 LF
REMOVE PIPE - WATERMAIN	0 LF
REMOVE TREE	0 EA
SALVAGE MAIL BOX SUPPORT	7 EA

PROJECT TOTAL

RECLAMATION FULL-DEPTH	14351 SY
REMOVE PAVEMENT - BITUMINOUS	1022 SY
REMOVE PAVEMENT - CONCRETE	205 SY
REMOVE SURFACE - GRAVEL	79 SY
MILL BITUMINOUS PAVEMENT	55 SY
SAWCUT PAVEMENT - FULL DEPTH	823 LF
REMOVE PIPE - STORM	540 LF
REMOVE PIPE - WATERMAIN	20 LF
REMOVE TREE	3 EA
SALVAGE MAIL BOX SUPPORT	28 EA

DATE	REVISION

I hereby certify that this plan, specification, or report was prepared by me or under my direct supervision and that I am a duly Licensed Professional Engineer Under the laws of the State of Minnesota

Joe Feriancek
JOE FERIANCEK
 Date 1/23/24 Lic. No. 57095

DESIGNED BY:	JJF
DRAWN BY:	JJF
CHECKED BY:	BRW
DATE:	12/15/23
FILE:	24-02

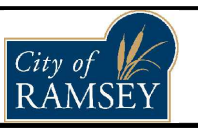

CITY OF RAMSEY
 7550 SUNWOOD DRIVE
 RAMSEY, MN 55303
 (763) 427-1410 FAX (763) 433-9898

EXISTING CONDITIONS & REMOVALS

HALLS DOVER ACRES STREET RECONSTRUCTIONS
 CITY PROJECT NO. 24-02
 CITY OF RAMSEY, MINNESOTA

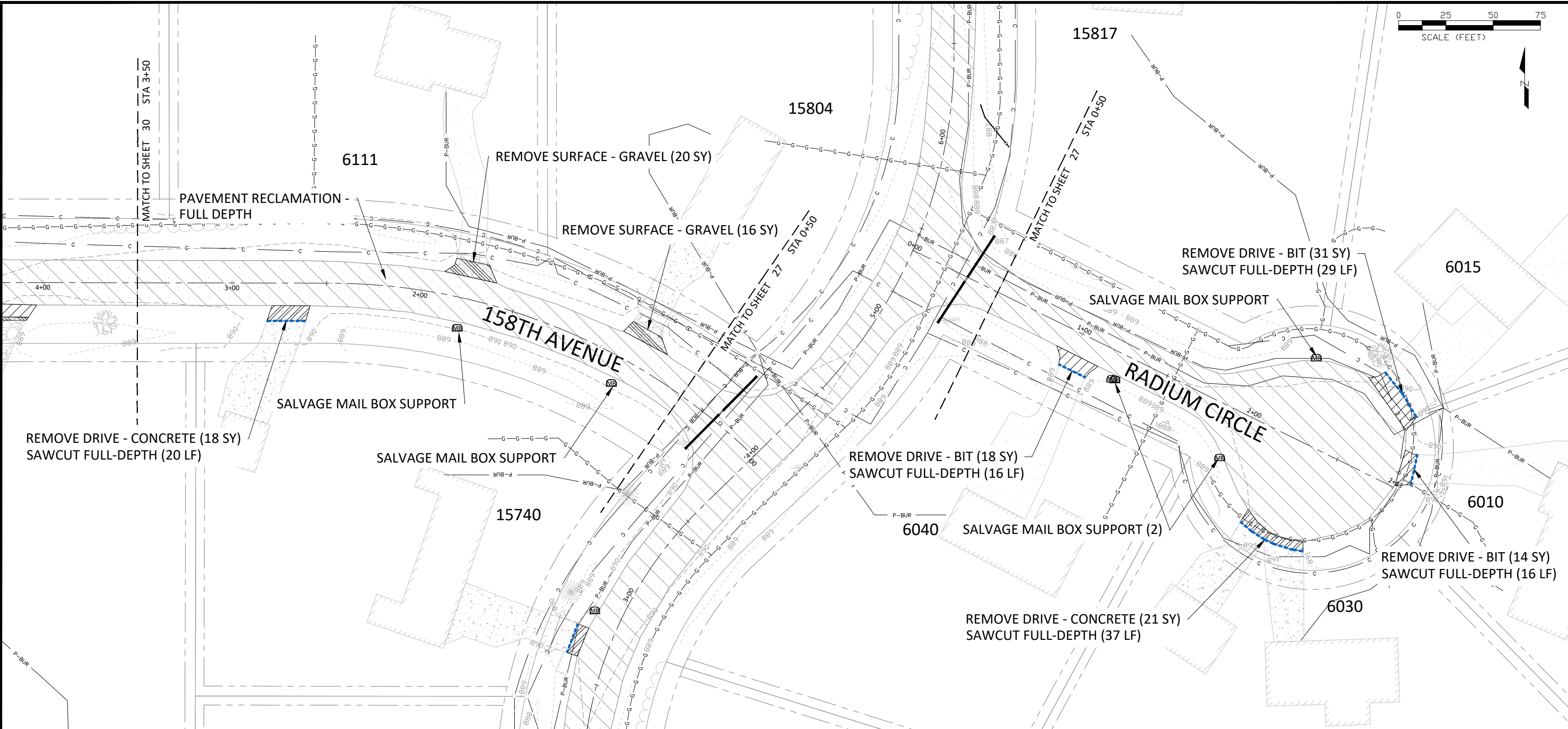
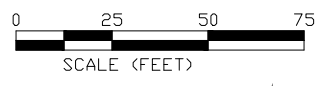

LEGEND

	RECLAMATION - FULL DEPTH		TREE SAVE FENCE
	REMOVE PAVEMENT - BITUMINOUS		SILT FENCE
	REMOVE PAVEMENT - CONCRETE		DRAINAGE & UTILITY EASEMENT LINE
	REMOVE SURFACE - GRAVEL		RIGHT OF WAY LINE
	MILL BITUMINOUS PAVEMENT - STREET TIE-IN		SECTION LINE
	REMOVE PIPE - STORM		TREE LINE
	REMOVE PIPE - WATERMAIN		OVERHEAD POWER LINE
	SAWCUT PAVEMENT - FULL DEPTH		BURIED POWER LINE
	CONSTRUCTION LIMITS		FIBER OPTIC LINE
	REMOVE TREE (INDIVIDUAL)		COMMUNICATION LINE
	SALVAGE MAIL BOX SUPPORT		GAS LINE

NOTE:

1. REMOVALS WILL BE MARKED IN THE FIELD BY CITY STAFF. ALL REMOVALS MUST BE SAWCUT.
2. REMOVALS CULVERT ENDS IS INCIDENTAL TO REMOVE PIPE -SEWER PAY ITEM.
3. PROTECT LANDSCAPING AND IRRIGATION. PROPERTY OWNERS ARE TO LOCATE AND MOVE IRRIGATION BEFORE CONSTRUCTION.

REMOVALS SUMMARY: 158TH AVE. STA. 0+50 TO 3+50

RECLAMATION FULL-DEPTH	1966 SY
REMOVE PAVEMENT - BITUMINOUS	63 SY
REMOVE PAVEMENT - CONCRETE	39 SY
REMOVE SURFACE - GRAVEL	36 SY
MILL BITUMINOUS PAVEMENT	0 SY
SAWCUT PAVEMENT - FULL DEPTH	118 LF
REMOVE PIPE - STORM	0 LF
REMOVE PIPE - WATERMAIN	0 LF
REMOVE TREE	0 EA
SALVAGE MAIL BOX SUPPORT	5 EA

PROJECT TOTAL

RECLAMATION FULL-DEPTH	14351 SY
REMOVE PAVEMENT - BITUMINOUS	1022 SY
REMOVE PAVEMENT - CONCRETE	205 SY
REMOVE SURFACE - GRAVEL	79 SY
MILL BITUMINOUS PAVEMENT	55 SY
SAWCUT PAVEMENT - FULL DEPTH	823 LF
REMOVE PIPE - STORM	540 LF
REMOVE PIPE - WATERMAIN	20 LF
REMOVE TREE	3 EA
SALVAGE MAIL BOX SUPPORT	28 EA

DATE	REVISION

I hereby certify that this plan, specification, or report was prepared by me or under my direct supervision and that I am a duly Licensed Professional Engineer Under the laws of the State of Minnesota

Joe Feriancek
 JOE FERIANCEK
 Date: 1/23/24 Lic. No. 57095

DESIGNED BY:	JJF
DRAWN BY:	JJF
CHECKED BY:	BRW

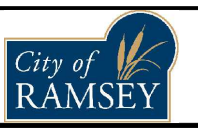

CITY OF RAMSEY
 7550 SUNWOOD DRIVE
 RAMSEY, MN 55303
 (763) 427-1410 FAX (763) 433-9898

EXISTING CONDITIONS & REMOVALS

HALLS DOVER ACRES STREET RECONSTRUCTIONS
 CITY PROJECT NO. 24-02
 CITY OF RAMSEY, MINNESOTA

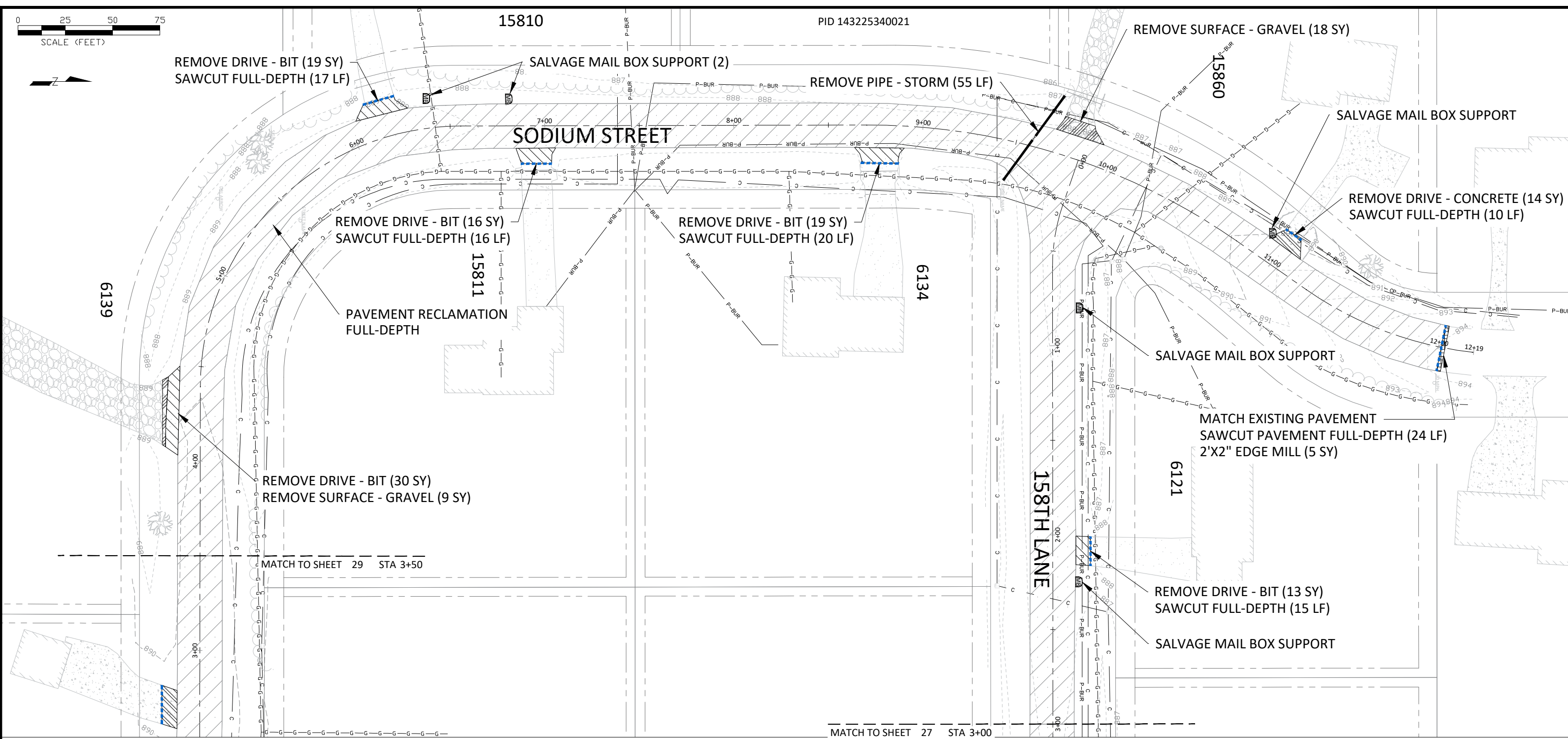

LEGEND

	RECLAMATION - FULL DEPTH		TREE SAVE FENCE
	REMOVE PAVEMENT - BITUMINOUS		SILT FENCE
	REMOVE PAVEMENT - CONCRETE		DRAINAGE & UTILITY EASEMENT LINE
	REMOVE SURFACE - GRAVEL		RIGHT OF WAY LINE
	MILL BITUMINOUS PAVEMENT - STREET TIE-IN		SECTION LINE
	REMOVE PIPE - STORM		TREE LINE
	REMOVE PIPE - WATERMAIN		OVERHEAD POWER LINE
	SAWCUT PAVEMENT - FULL DEPTH		BURIED POWER LINE
	CONSTRUCTION LIMITS		FIBER OPTIC LINE
	REMOVE TREE (INDIVIDUAL)		COMMUNICATION LINE
	SALVAGE MAIL BOX SUPPORT		GAS LINE

NOTE:

1. REMOVALS WILL BE MARKED IN THE FIELD BY CITY STAFF. ALL REMOVALS MUST BE SAWCUT.
2. REMOVALS CULVERT ENDS IS INCIDENTAL TO REMOVE PIPE -SEWER PAY ITEM.
3. PROTECT LANDSCAPING AND IRRIGATION. PROPERTY OWNERS ARE TO LOCATE AND MOVE IRRIGATION BEFORE CONSTRUCTION.

REMOVALS SUMMARY: SODIUM ST. STA. 3+50 TO END / 158TH LN. STA. 0+50 TO 3+00

RECLAMATION FULL-DEPTH	3075 SY
REMOVE PAVEMENT - BITUMINOUS	97 SY
REMOVE PAVEMENT - CONCRETE	14 SY
REMOVE SURFACE - GRAVEL	27 SY
MILL BITUMINOUS PAVEMENT	5 SY
SAWCUT PAVEMENT - FULL DEPTH	102 LF
REMOVE PIPE - STORM	55 LF
REMOVE PIPE - WATERMAIN	0 LF
REMOVE TREE	0 EA
SALVAGE MAIL BOX SUPPORT	5 EA

PROJECT TOTAL

RECLAMATION FULL-DEPTH	14351 SY
REMOVE PAVEMENT - BITUMINOUS	1022 SY
REMOVE PAVEMENT - CONCRETE	205 SY
REMOVE SURFACE - GRAVEL	79 SY
MILL BITUMINOUS PAVEMENT	55 SY
SAWCUT PAVEMENT - FULL DEPTH	823 LF
REMOVE PIPE - STORM	540 LF
REMOVE PIPE - WATERMAIN	20 LF
REMOVE TREE	3 EA
SALVAGE MAIL BOX SUPPORT	28 EA

DATE	REVISION

I hereby certify that this plan, specification, or report was prepared by me or under my direct supervision and that I am a duly Licensed Professional Engineer Under the laws of the State of Minnesota

Joe Feriancek
 JOE FERIANCEK
 Date 1/23/24 Lic. No. 57095

DESIGNED BY:	JJF
DRAWN BY:	JJF
CHECKED BY:	BRW
DATE:	12/15/23
FILE:	24-02

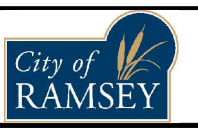

CITY OF RAMSEY
 7550 SUNWOOD DRIVE
 RAMSEY, MN 55303
 (763) 427-1410 FAX (763) 433-9898

EXISTING CONDITIONS & REMOVALS

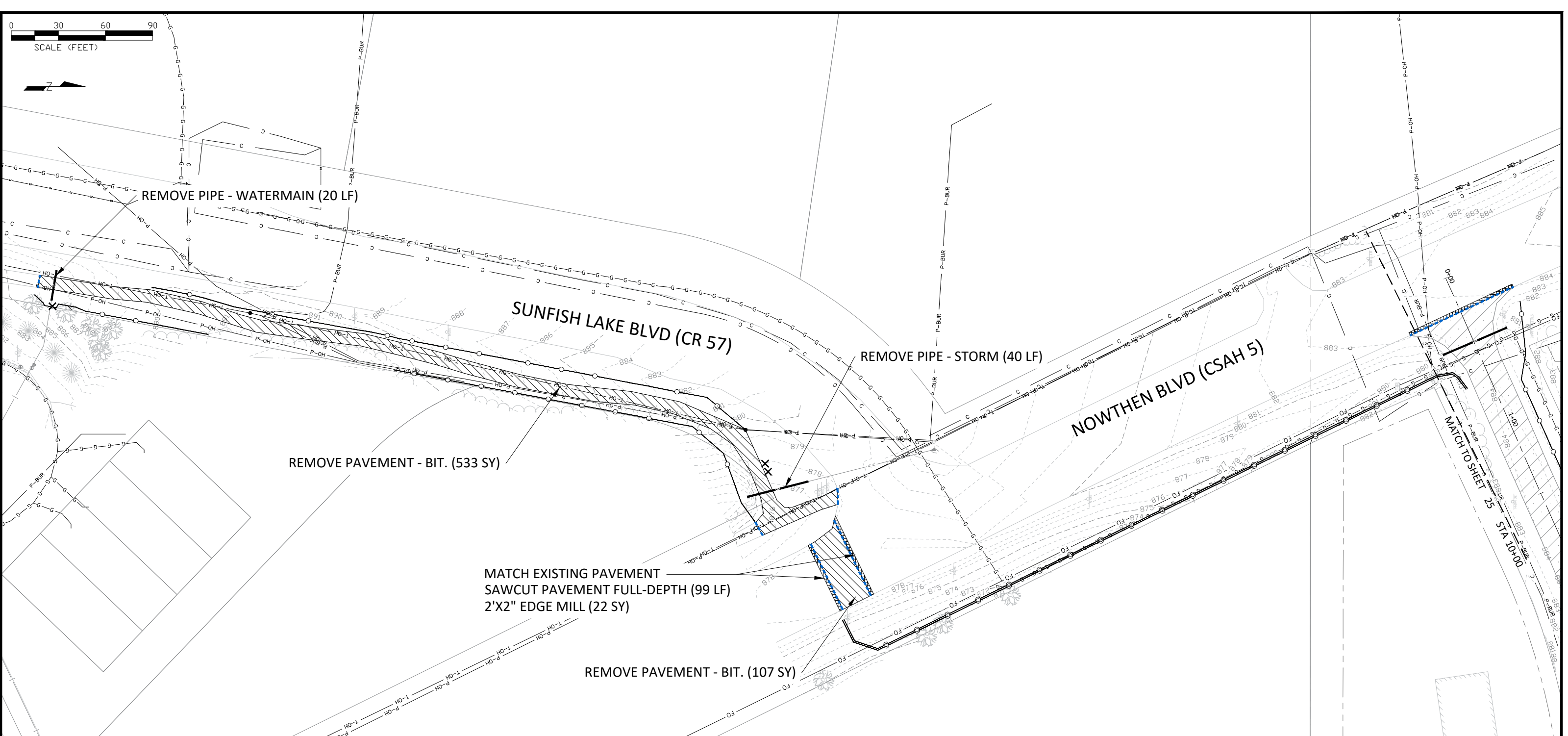
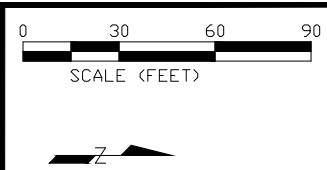

LEGEND

	RECLAMATION - FULL DEPTH		TREE SAVE FENCE
	REMOVE PAVEMENT - BITUMINOUS		SILT FENCE
	REMOVE PAVEMENT - CONCRETE		DRAINAGE & UTILITY EASEMENT LINE
	REMOVE SURFACE - GRAVEL		RIGHT OF WAY LINE
	MILL BITUMINOUS PAVEMENT - STREET TIE-IN		SECTION LINE
	REMOVE PIPE - STORM		TREE LINE
	REMOVE PIPE - WATERMAIN		OVERHEAD POWER LINE
	SAWCUT PAVEMENT - FULL DEPTH		BURIED POWER LINE
	CONSTRUCTION LIMITS		FIBER OPTIC LINE
	REMOVE TREE (INDIVIDUAL)		COMMUNICATION LINE
	SALVAGE MAIL BOX SUPPORT		GAS LINE

NOTE:

- REMOVALS WILL BE MARKED IN THE FIELD BY CITY STAFF. ALL REMOVALS MUST BE SAWCUT.
- REMOVALS CULVERT ENDS IS INCIDENTAL TO REMOVE PIPE -SEWER PAY ITEM.
- PROTECT LANDSCAPING AND IRRIGATION. PROPERTY OWNERS ARE TO LOCATE AND MOVE IRRIGATION BEFORE CONSTRUCTION.

REMOVALS SUMMARY: WATERMAIN ROUTE STA. 0+00 TO 10+00

RECLAMATION FULL-DEPTH	0 SY
REMOVE PAVEMENT - BITUMINOUS	640 SY
REMOVE PAVEMENT - CONCRETE	0 SY
REMOVE SURFACE - GRAVEL	0 SY
MILL BITUMINOUS PAVEMENT	22 SY
SAWCUT PAVEMENT - FULL DEPTH	126 LF
REMOVE PIPE - STORM	40 LF
REMOVE PIPE - WATERMAIN	20 LF
REMOVE TREE	3 EA
SALVAGE MAIL BOX SUPPORT	0 EA

PROJECT TOTAL

RECLAMATION FULL-DEPTH	14351 SY
REMOVE PAVEMENT - BITUMINOUS	1022 SY
REMOVE PAVEMENT - CONCRETE	205 SY
REMOVE SURFACE - GRAVEL	79 SY
MILL BITUMINOUS PAVEMENT	55 SY
SAWCUT PAVEMENT - FULL DEPTH	823 LF
REMOVE PIPE - STORM	540 LF
REMOVE PIPE - WATERMAIN	20 LF
REMOVE TREE	3 EA
SALVAGE MAIL BOX SUPPORT	28 EA

DATE	REVISION

I hereby certify that this plan, specification, or report was prepared by me or under my direct supervision and that I am a duly Licensed Professional Engineer Under the laws of the State of Minnesota

Joe Feriancek
 JOE FERIANCEK
 Date 1/23/24 Lic. No. 57095

DESIGNED BY:	JJF
DRAWN BY:	JJF
CHECKED BY:	BRW

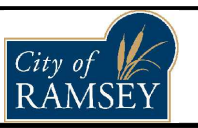

CITY OF RAMSEY
 7550 SUNWOOD DRIVE
 RAMSEY, MN 55303
 (763) 427-1410 FAX (763) 433-9898

EXISTING CONDITIONS & REMOVALS

HALLS DOVER ACRES STREET RECONSTRUCTIONS
 CITY PROJECT NO. 24-02
 CITY OF RAMSEY, MINNESOTA

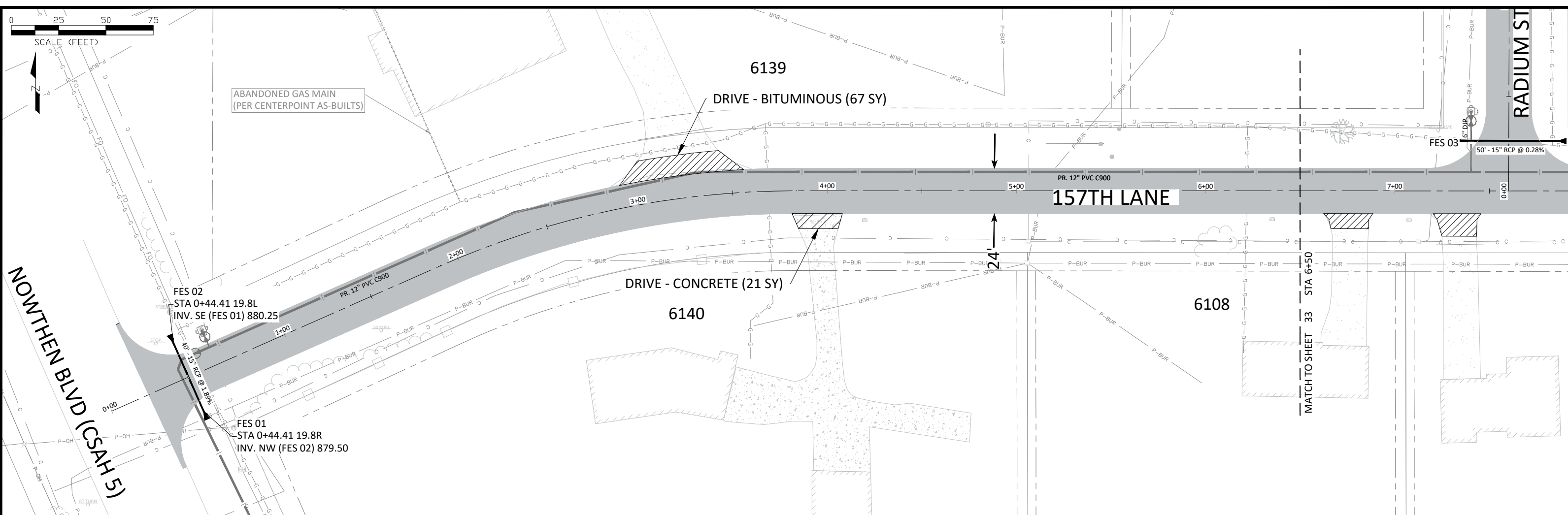

LEGEND		GENERAL NOTES:	
	CONSTRUCTION LIMITS		PR. DRIVE - BITUMINOUS
	DRAINAGE & UTILITY EASEMENT LINE		PR. DRIVE - CONCRETE
	RIGHT OF WAY LINE		PR. DRIVE - CLASS 5 SURFACE
	PR. BITUMINOUS PAVEMENT - ROADWAY		HYDRANT
	PR. BITUMINOUS PAVEMENT - COUNTY		WATER VALVE
	PR. BITUMINOUS PAVEMENT - TRAIL		WATERMAIN
	PR. 6\"/>		

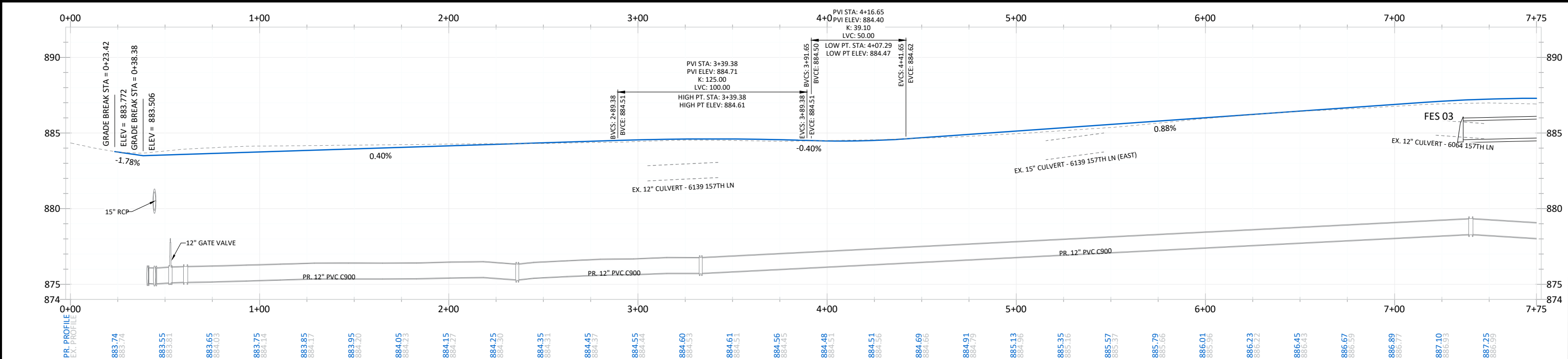

DATE: _____ REVISION: _____ I hereby certify that this plan, specification, or report was prepared by me or under my direct supervision and that I am a duly Licensed Professional Engineer Under the laws of the State of Minnesota. Date: 1/23/24 Lic. No. 57095	DESIGNED BY: JJF DRAWN BY: JJF CHECKED BY: BRW DATE: 12/15/23 FILE: 24-02	 CITY OF RAMSEY 7550 SUNWOOD DRIVE RAMSEY, MN 55303 (763) 427-1410 FAX (763) 433-9898	STREET & STORM SEWER HALLS DOVER ACRES STREET RECONSTRUCTIONS CITY PROJECT NO. 24-02 CITY OF RAMSEY, MINNESOTA	SHEET 32 OF 65 SHEETS
---	---	--	--	-----------------------

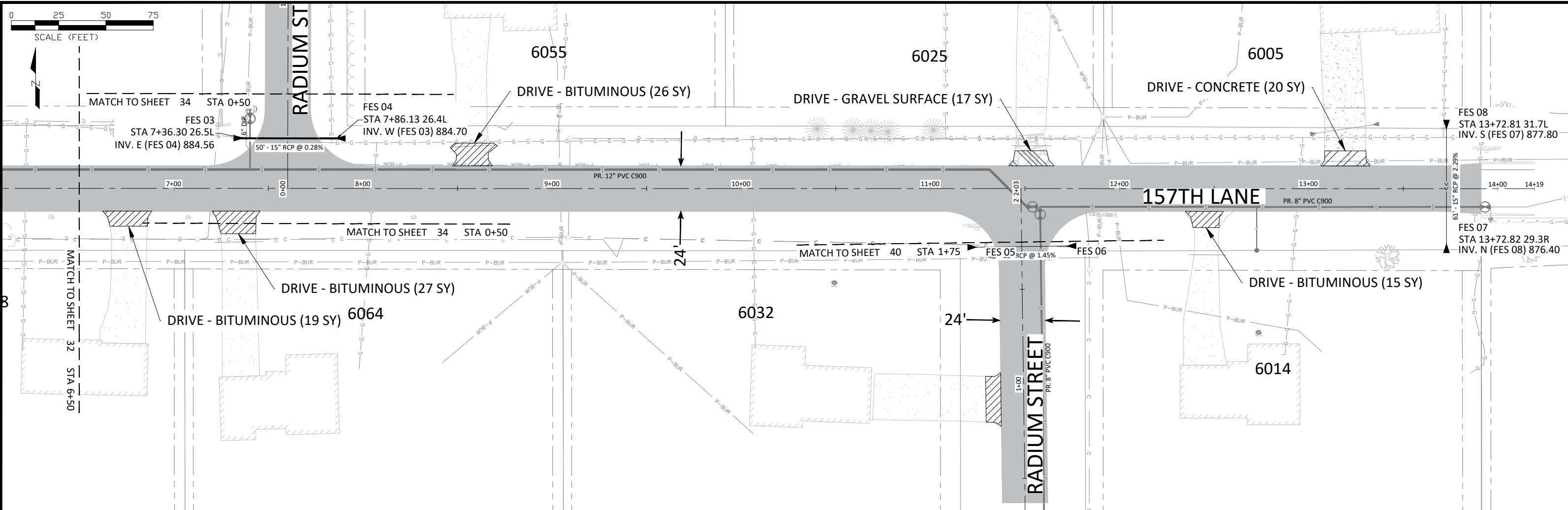

LEGEND

- CONSTRUCTION LIMITS
- - - DRAINAGE & UTILITY EASEMENT LINE
- RIGHT OF WAY LINE
- PR. BITUMINOUS PAVEMENT - ROADWAY
- PR. BITUMINOUS PAVEMENT - COUNTY
- PR. BITUMINOUS PAVEMENT - TRAIL
- PR. 6" CONCRETE WALK
- PR. DRIVE - BITUMINOUS
- PR. DRIVE - CONCRETE
- PR. DRIVE - CLASS 5 SURFACE
- HYDRANT
- WATER VALVE
- WATERMAIN
- PR. STORM SEWER
- PR. FLARED END SECTION

GENERAL NOTES:

1. ALL RADII TO BE CONSTRUCTED AT 30', UNLESS OTHERWISE NOTED.
2. TYPICAL SECTIONS SEE SHEET 04.
3. PEDESTRIAN RAMP DETAILS SEE SHEETS 09 - 14.
4. PIPE LENGTH DOES NOT INCLUDE FLARED ENDS. FLARED END INVERTS MEASURED AT PIPE, NOT END OF FLARE.

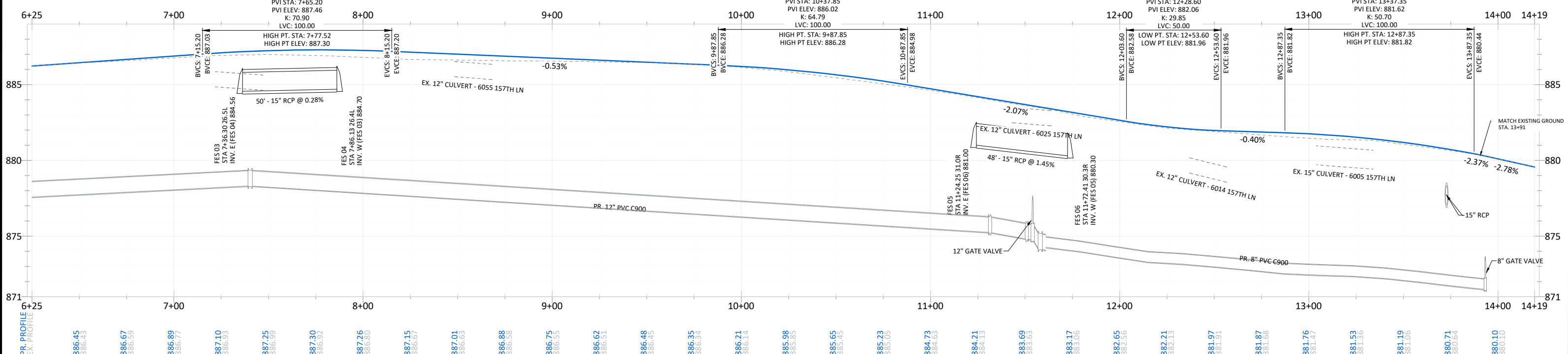

DATE: 3/28/24	REVISION: ADD 1" WATER SERVICE - 6014 157TH LN.	DESIGNED BY: JJF	<p>CITY OF RAMSEY 7550 SUNWOOD DRIVE RAMSEY, MN 55303 (763) 427-1410 FAX (763) 433-9898</p>	<p>STREET & STORM SEWER</p>	<p>HALLS DOVER ACRES STREET RECONSTRUCTIONS CITY PROJECT NO. 24-02 CITY OF RAMSEY, MINNESOTA</p>	<p>SHEET 33 OF 65 SHEETS</p>
DATE: 12/15/23	DRAWN BY: JJF	<p>1 I hereby certify that this plan, specification, or report was prepared by me or under my direct supervision and that I am a duly Licensed Professional Engineer Under the laws of the State of Minnesota</p> <p><i>Joe Feriancek</i> JOE FERIANCEK Date: 1/23/24 Lic. No. 57095</p>				
DATE: 24-02	CHECKED BY: BRW	<p>PR. PROFILE EX. PROFILE 886.45 886.45 886.67 886.59 886.89 886.77 887.10 886.93 887.25 886.99 887.30 886.92 887.26 886.80 887.15 886.67 887.01 886.63 886.88 886.58 886.75 886.55 886.62 886.51 886.48 886.45 886.35 886.34 886.21 886.14 885.98 885.85 885.65 885.45 885.23 885.05 884.73 884.63 884.21 884.13 883.69 883.63 883.17 883.06 882.65 882.56 882.21 882.13 881.97 881.91 881.87 881.68 881.76 881.47 881.53 881.36 881.19 881.06 880.71 880.64 880.10 880.10</p>				

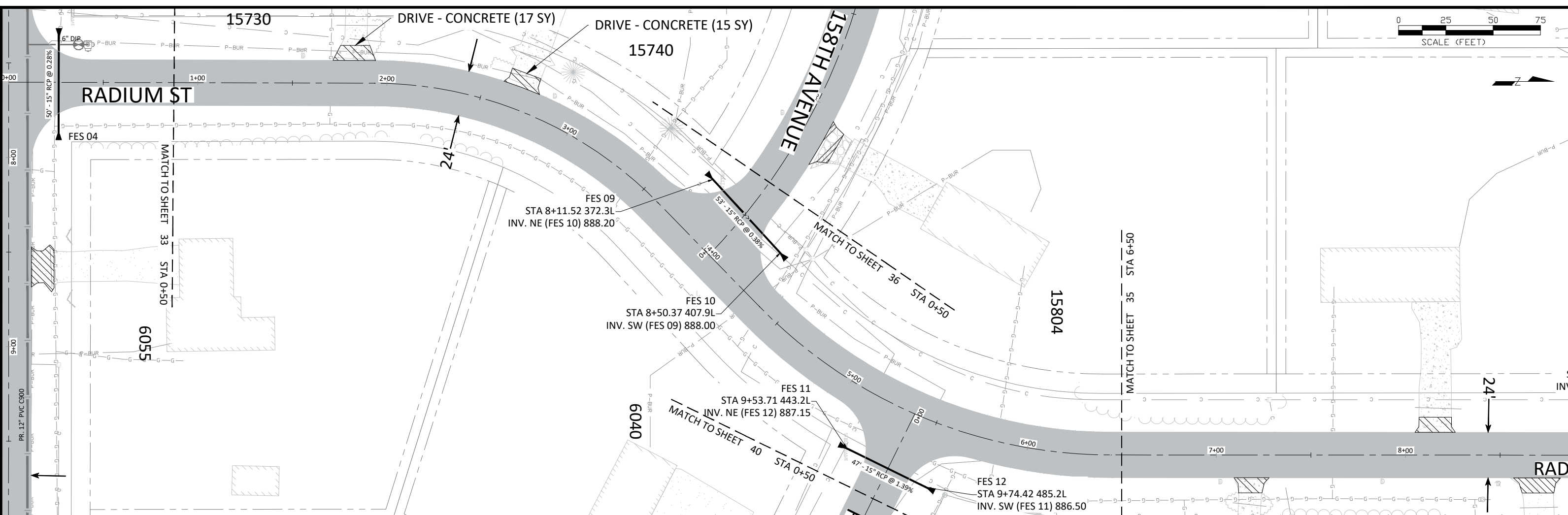
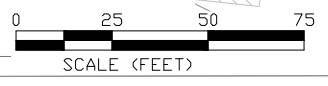

LEGEND

CONSTRUCTION LIMITS	PR. BITUMINOUS PAVEMENT - ROADWAY	PR. DRIVE - BITUMINOUS	HYDRANT WATER VALVE
DRAINAGE & UTILITY EASEMENT LINE	PR. BITUMINOUS PAVEMENT - COUNTY	PR. DRIVE - CONCRETE	WATERMAIN
RIGHT OF WAY LINE	PR. BITUMINOUS PAVEMENT - TRAIL	PR. DRIVE - CLASS 5 SURFACE	PR. STORM SEWER
	PR. 6" CONCRETE WALK		PR. FLARED END SECTION

GENERAL NOTES:

1. ALL RADII TO BE CONSTRUCTED AT 30', UNLESS OTHERWISE NOTED.
2. TYPICAL SECTIONS SEE SHEET 04.
3. PEDESTRIAN RAMP DETAILS SEE SHEETS 09 - 14 .
4. PIPE LENGTH DOES NOT INCLUDE FLARED ENDS. FLARED END INVERTS MEASURED AT PIPE, NOT END OF FLARE.

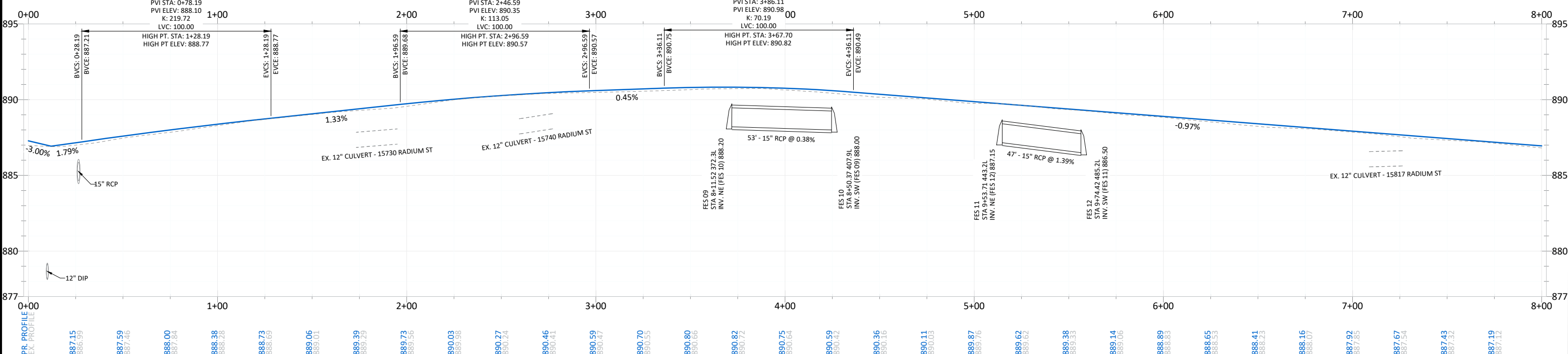

DATE	REVISION

I hereby certify that this plan, specification, or report was prepared by me or under my direct supervision and that I am a duly Licensed Professional Engineer Under the laws of the State of Minnesota

Joe Feriancek
 JOE FERIANCEK
 Date: 1/23/24 Lic. No. 57095

DESIGNED BY: JJF
 DRAWN BY: JJF
 CHECKED BY: BRW

DATE: 12/15/23
 FILE: 24-02

CITY OF RAMSEY
 7550 SUNWOOD DRIVE
 RAMSEY, MN 55303
 (763) 427-1410 FAX (763) 433-9898

STREET & STORM SEWER

HALLS DOVER ACRES STREET RECONSTRUCTIONS
 CITY PROJECT NO. 24-02
 CITY OF RAMSEY, MINNESOTA

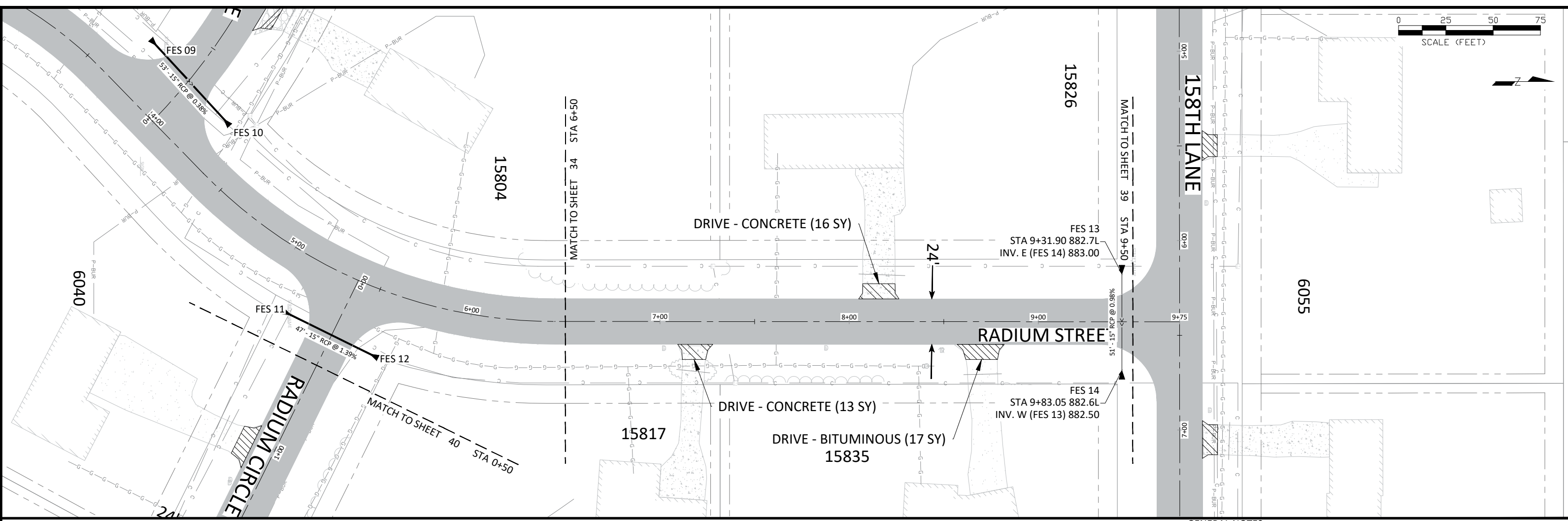
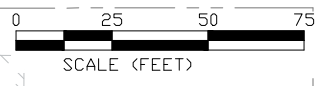

LEGEND

	CONSTRUCTION LIMITS
	DRAINAGE & UTILITY EASEMENT LINE
	RIGHT OF WAY LINE

	PR. BITUMINOUS PAVEMENT - ROADWAY
	PR. BITUMINOUS PAVEMENT - COUNTY
	PR. BITUMINOUS PAVEMENT - TRAIL
	PR. 6" CONCRETE WALK

	PR. DRIVE - BITUMINOUS
	PR. DRIVE - CONCRETE
	PR. DRIVE - CLASS 5 SURFACE

	HYDRANT
	WATER VALVE
	WATERMAIN
	PR. STORM SEWER
	PR. FLARED END SECTION

GENERAL NOTES:

1. ALL RADII TO BE CONSTRUCTED AT 30', UNLESS OTHERWISE NOTED.
2. TYPICAL SECTIONS SEE SHEET 04.
3. PEDESTRIAN RAMP DETAILS SEE SHEETS 09 - 14 .
4. PIPE LENGTH DOES NOT INCLUDE FLARED ENDS. FLARED END INVERTS MEASURED AT PIPE, NOT END OF FLARE.

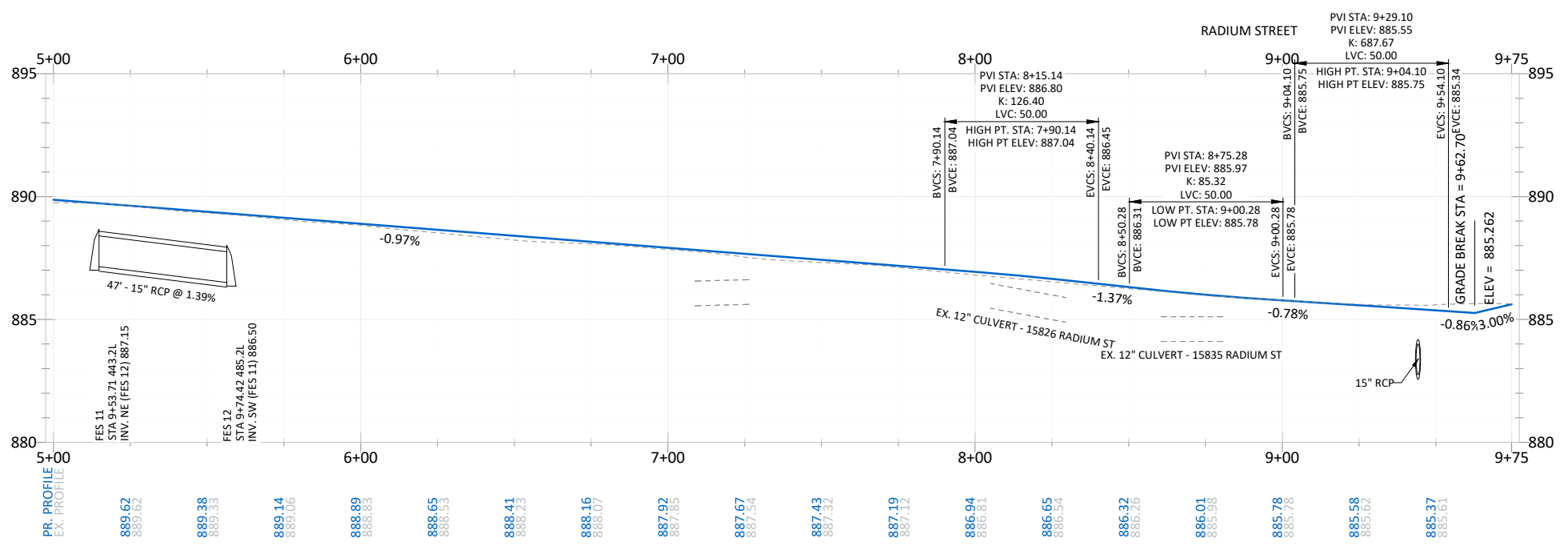

DATE	REVISION

I hereby certify that this plan, specification, or report was prepared by me or under my direct supervision and that I am a duly Licensed Professional Engineer Under the laws of the State of Minnesota

Joe Feriancek
JOE FERIANCEK
 Date: 1/23/24 Lic. No. 57095

DESIGNED BY:	JJF
DRAWN BY:	JJF
CHECKED BY:	BRW

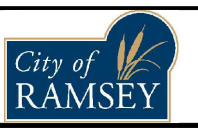

CITY OF RAMSEY
 7550 SUNWOOD DRIVE
 RAMSEY, MN 55303
 (763) 427-1410 FAX (763) 433-9898

STREET & STORM SEWER

HALLS DOVER ACRES STREET RECONSTRUCTIONS
 CITY PROJECT NO. 24-02
 CITY OF RAMSEY, MINNESOTA

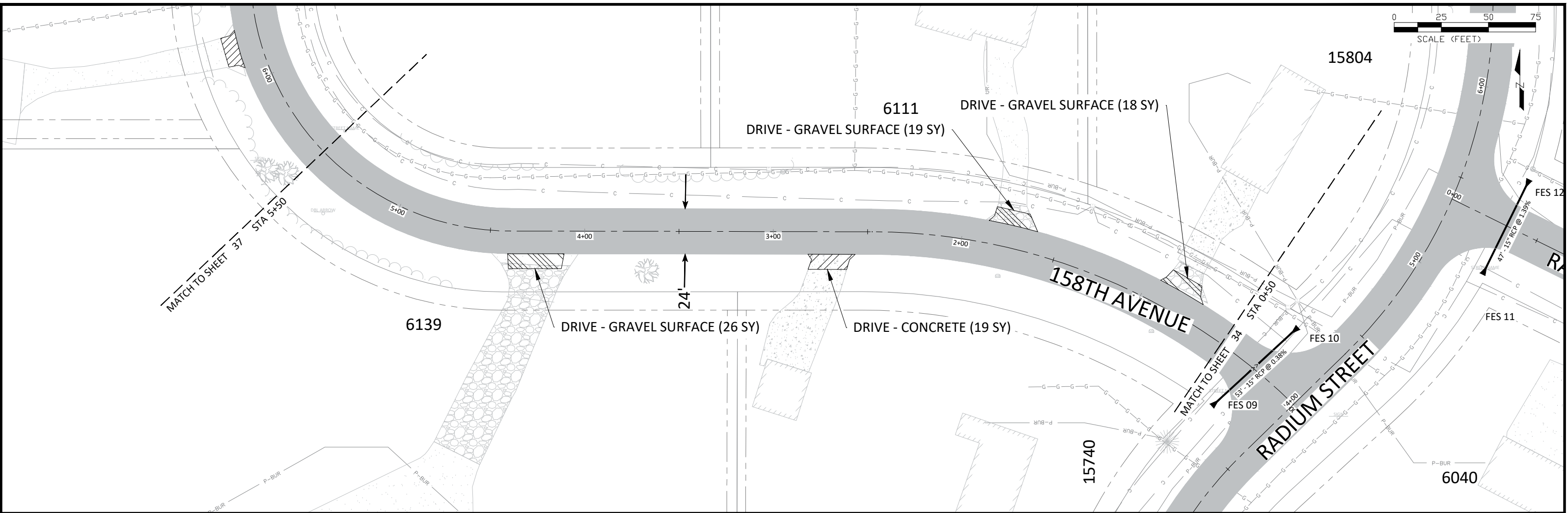

LEGEND		GENERAL NOTES:	
	CONSTRUCTION LIMITS		PR. BITUMINOUS PAVEMENT - ROADWAY
	DRAINAGE & UTILITY EASEMENT LINE		PR. BITUMINOUS PAVEMENT - COUNTY
	RIGHT OF WAY LINE		PR. BITUMINOUS PAVEMENT - TRAIL
			PR. DRIVE - BITUMINOUS
			PR. DRIVE - CONCRETE
			PR. DRIVE - CLASS 5 SURFACE
			HYDRANT
			WATER VALVE
			WATERMAIN
			PR. STORM SEWER
			PR. FLARED END SECTION

1. ALL RADII TO BE CONSTRUCTED AT 30', UNLESS OTHERWISE NOTED.
2. TYPICAL SECTIONS SEE SHEET 04.
3. PEDESTRIAN RAMP DETAILS SEE SHEETS 09 - 14 .
4. PIPE LENGTH DOES NOT INCLUDE FLARED ENDS. FLARED END INVERTS MEASURED AT PIPE, NOT END OF FLARE.

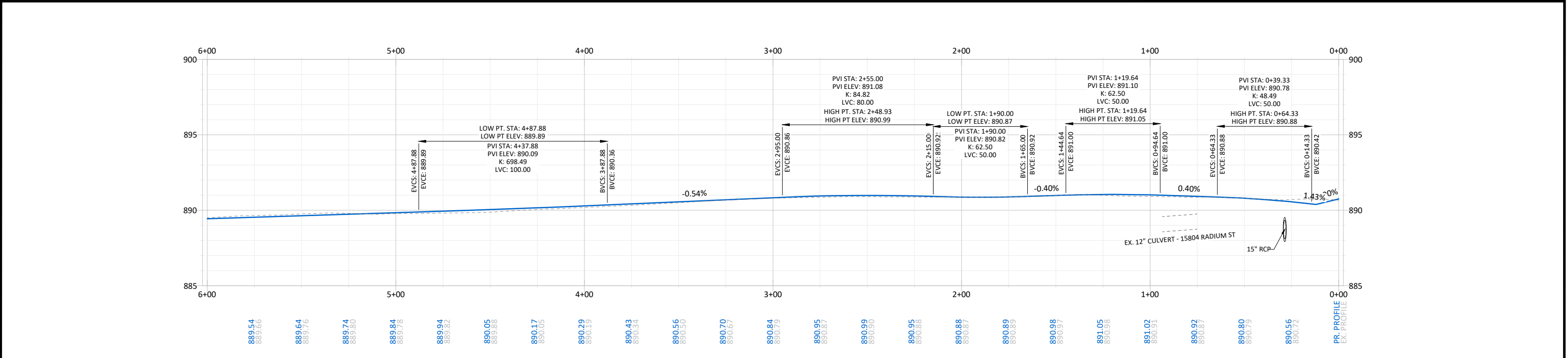

DATE	REVISION

I hereby certify that this plan, specification, or report was prepared by me or under my direct supervision and that I am a duly Licensed Professional Engineer Under the laws of the State of Minnesota

Joe Feriancek
 JOE FERIANCEK
 Date: 1/23/24 Lic. No. 57095

DESIGNED BY: JJF
 DRAWN BY: JJF
 CHECKED BY: BRW

DATE: 12/15/23
 FILE: 24-02

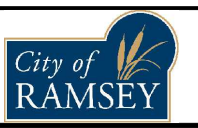

CITY OF RAMSEY
 7550 SUNWOOD DRIVE
 RAMSEY, MN 55303
 (763) 427-1410 FAX (763) 433-9898

STREET & STORM SEWER

HALLS DOVER ACRES STREET RECONSTRUCTIONS
 CITY PROJECT NO. 24-02
 CITY OF RAMSEY, MINNESOTA

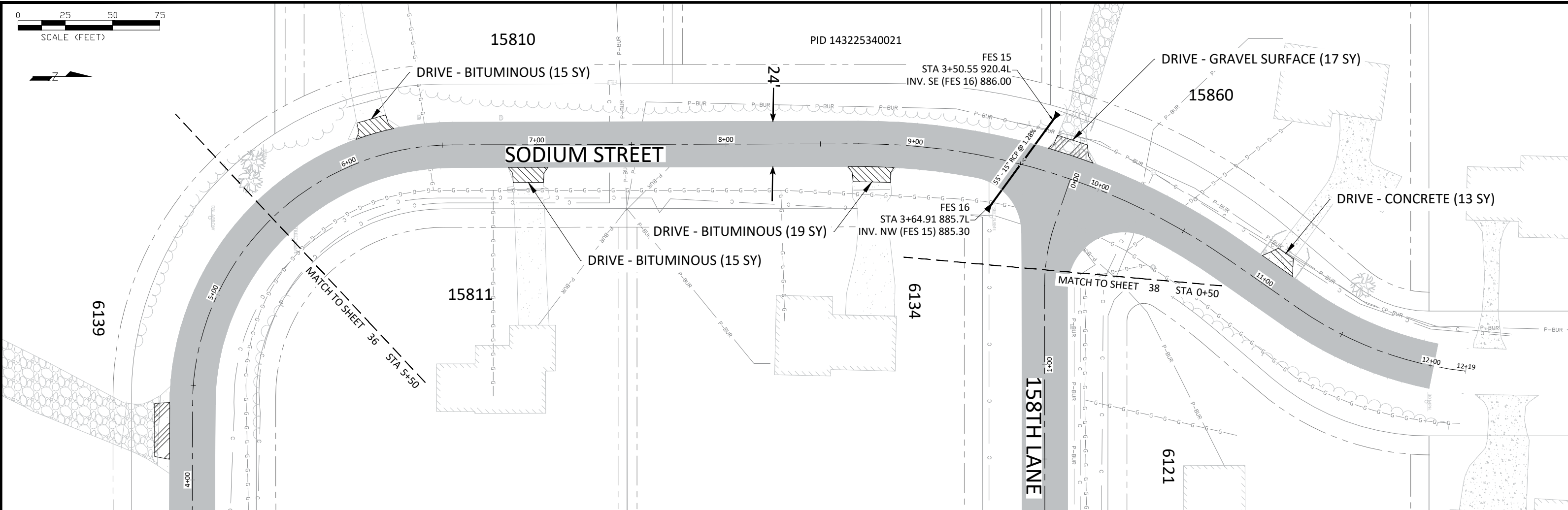

LEGEND

- CONSTRUCTION LIMITS
- - - DRAINAGE & UTILITY EASEMENT LINE
- RIGHT OF WAY LINE
- PR. BITUMINOUS PAVEMENT - ROADWAY
- PR. BITUMINOUS PAVEMENT - COUNTY
- PR. BITUMINOUS PAVEMENT - TRAIL
-
- PR. DRIVE - BITUMINOUS
- PR. DRIVE - CONCRETE
- PR. DRIVE - CLASS 5 SURFACE
- HYDRANT
- WATER VALVE
- WATERMAIN
- PR. STORM SEWER
- PR. FLARED END SECTION

- GENERAL NOTES:**
1. ALL RADII TO BE CONSTRUCTED AT 30', UNLESS OTHERWISE NOTED.
 2. TYPICAL SECTIONS SEE SHEET 04.
 3. PEDESTRIAN RAMP DETAILS SEE SHEETS 09 - 14 .
 4. PIPE LENGTH DOES NOT INCLUDE FLARED ENDS. FLARED END INVERTS MEASURED AT PIPE, NOT END OF FLARE.

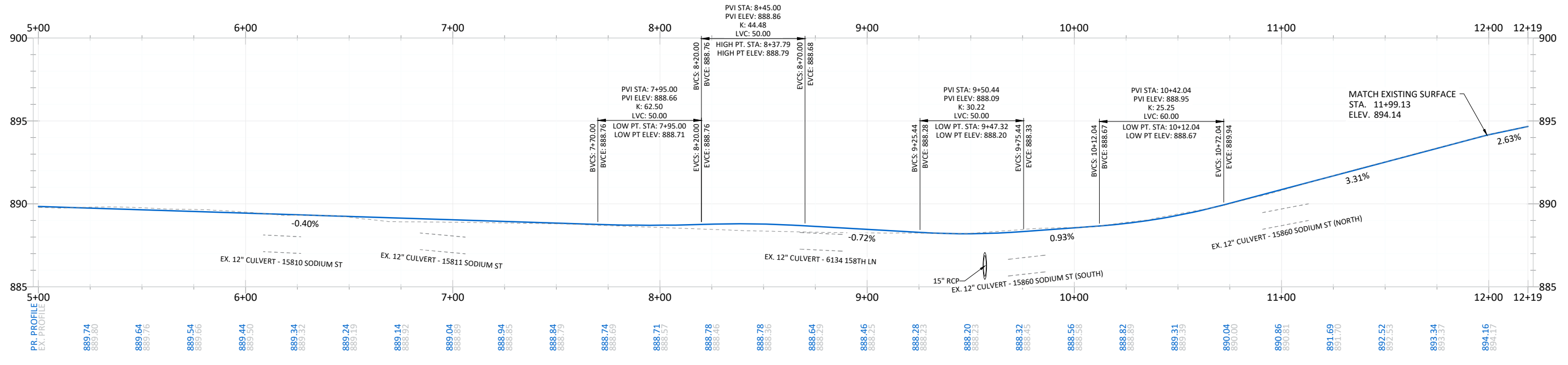

DATE	REVISION

I hereby certify that this plan, specification, or report was prepared by me or under my direct supervision and that I am a duly Licensed Professional Engineer Under the laws of the State of Minnesota

Joe Feriancek
 JOE FERIANCEK
 Date: 1/23/24 Lic. No. 57095

DESIGNED BY: JJF
 DRAWN BY: JJF
 CHECKED BY: BRW

DATE: 12/15/23
 FILE: 24-02

CITY OF RAMSEY
 7550 SUNWOOD DRIVE
 RAMSEY, MN 55303
 (763) 427-1410 FAX (763) 433-9898

STREET & STORM SEWER

HALLS DOVER ACRES STREET RECONSTRUCTIONS
 CITY PROJECT NO. 24-02
 CITY OF RAMSEY, MINNESOTA

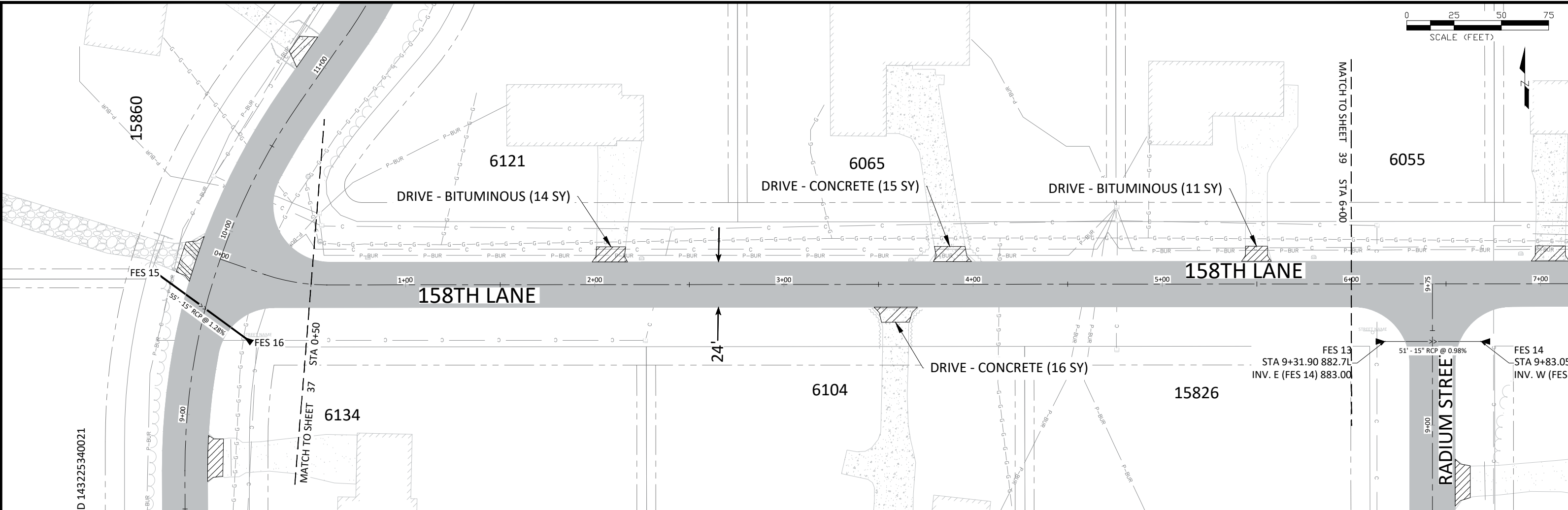
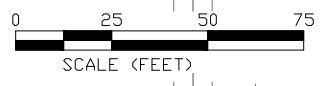

LEGEND

- CONSTRUCTION LIMITS
- - - DRAINAGE & UTILITY EASEMENT LINE
- RIGHT OF WAY LINE
- PR. BITUMINOUS PAVEMENT - ROADWAY
- PR. BITUMINOUS PAVEMENT - COUNTY
- PR. BITUMINOUS PAVEMENT - TRAIL
- PR. 6" CONCRETE WALK
- PR. DRIVE - BITUMINOUS
- PR. DRIVE - CONCRETE
- PR. DRIVE - CLASS 5 SURFACE
- HYDRANT
- WATER VALVE
- WATERMAIN
- PR. STORM SEWER
- PR. FLARED END SECTION

GENERAL NOTES:

1. ALL RADII TO BE CONSTRUCTED AT 30', UNLESS OTHERWISE NOTED.
2. TYPICAL SECTIONS SEE SHEET 04.
3. PEDESTRIAN RAMP DETAILS SEE SHEETS 09 - 14.
4. PIPE LENGTH DOES NOT INCLUDE FLARED ENDS. FLARED END INVERTS MEASURED AT PIPE, NOT END OF FLARE.

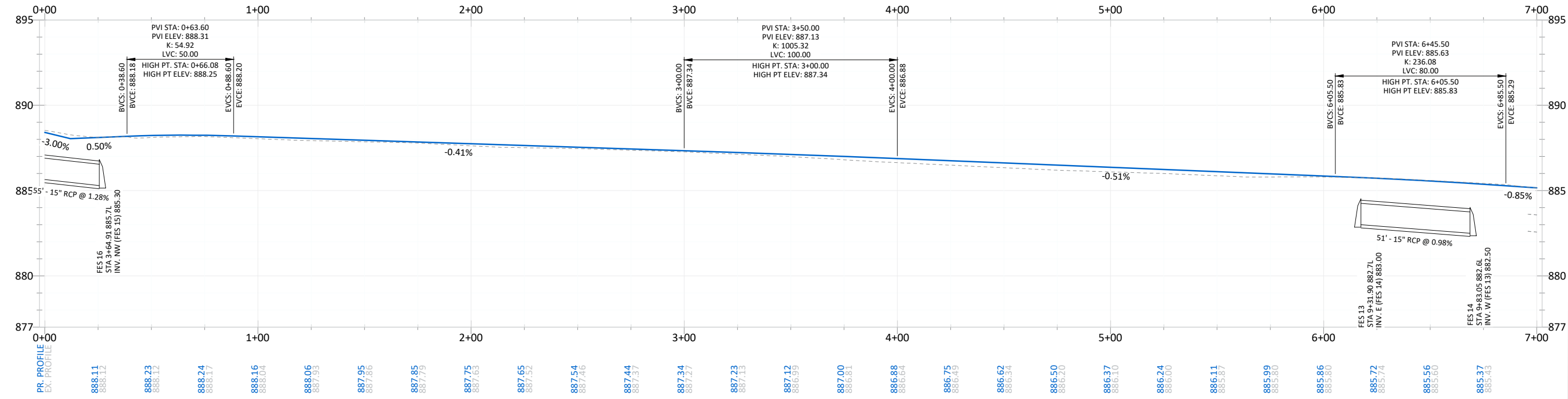

DATE	REVISION

I hereby certify that this plan, specification, or report was prepared by me or under my direct supervision and that I am a duly Licensed Professional Engineer Under the laws of the State of Minnesota

Joe Feriancek
JOE FERIANCEK
 Date: 1/23/24 Lic. No. 57095

DESIGNED BY: JJF
 DRAWN BY: JJF
 CHECKED BY: BRW

DATE: 12/15/23
 FILE: 24-02

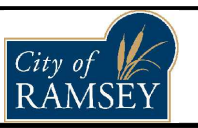

CITY OF RAMSEY
 7550 SUNWOOD DRIVE
 RAMSEY, MN 55303
 (763) 427-1410 FAX (763) 433-9898

STREET & STORM SEWER

HALLS DOVER ACRES STREET RECONSTRUCTIONS
 CITY PROJECT NO. 24-02
 CITY OF RAMSEY, MINNESOTA

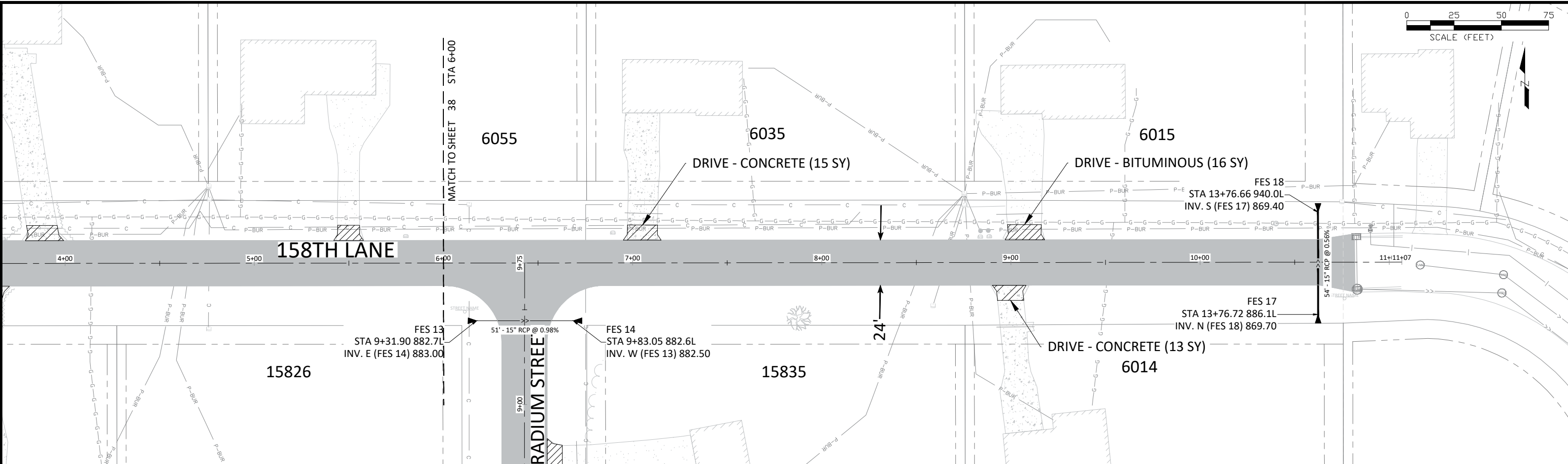

LEGEND

	CONSTRUCTION LIMITS		PR. BITUMINOUS PAVEMENT - ROADWAY		PR. DRIVE - BITUMINOUS		HYDRANT
	DRAINAGE & UTILITY EASEMENT LINE		PR. BITUMINOUS PAVEMENT - COUNTY		PR. DRIVE - CONCRETE		WATERMAIN
	RIGHT OF WAY LINE		PR. BITUMINOUS PAVEMENT - TRAIL		PR. DRIVE - CLASS 5 SURFACE		PR. STORM SEWER
			PR. 6" CONCRETE WALK				PR. FLARED END SECTION

GENERAL NOTES:

1. ALL RADII TO BE CONSTRUCTED AT 30', UNLESS OTHERWISE NOTED.
2. TYPICAL SECTIONS SEE SHEET 04.
3. PEDESTRIAN RAMP DETAILS SEE SHEETS 09 - 14.
4. PIPE LENGTH DOES NOT INCLUDE FLARED ENDS. FLARED END INVERTS MEASURED AT PIPE, NOT END OF FLARE.

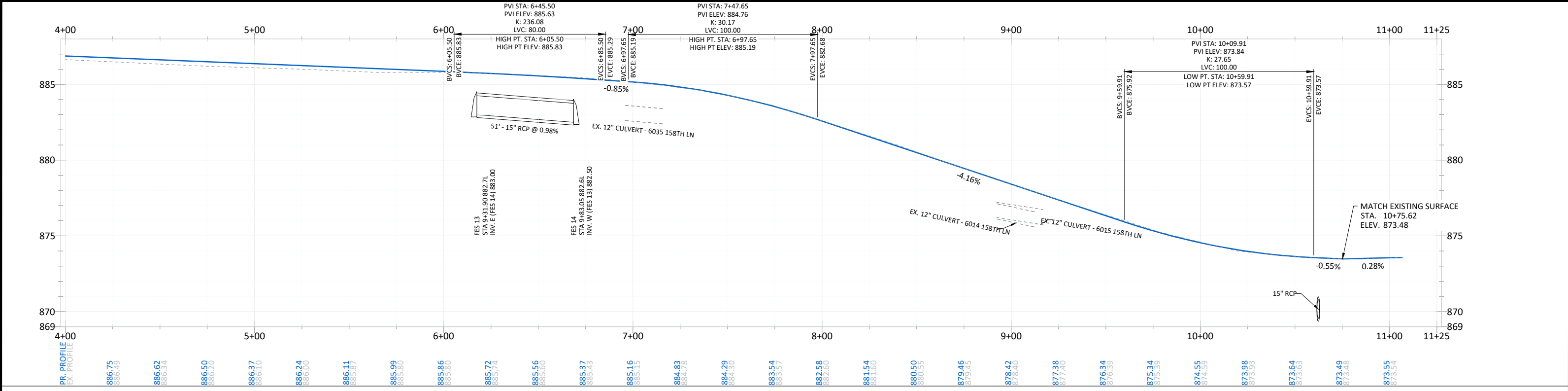

DATE	REVISION	I hereby certify that this plan, specification, or report was prepared by me or under my direct supervision and that I am a duly Licensed Professional Engineer Under the laws of the State of Minnesota	DESIGNED BY: JJF	<p>CITY OF RAMSEY 7550 SUNWOOD DRIVE RAMSEY, MN 55303 (763) 427-1410 FAX (763) 433-9898</p>	STREET & STORM SEWER	HALLS DOVER ACRES STREET RECONSTRUCTIONS CITY PROJECT NO. 24-02 CITY OF RAMSEY, MINNESOTA	SHEET 39 OF 65 SHEETS
			DRAWN BY: JJF				
		JOE FERIANECK Date: 1/23/24 Lic. No. 57095	CHECKED BY: BRW				

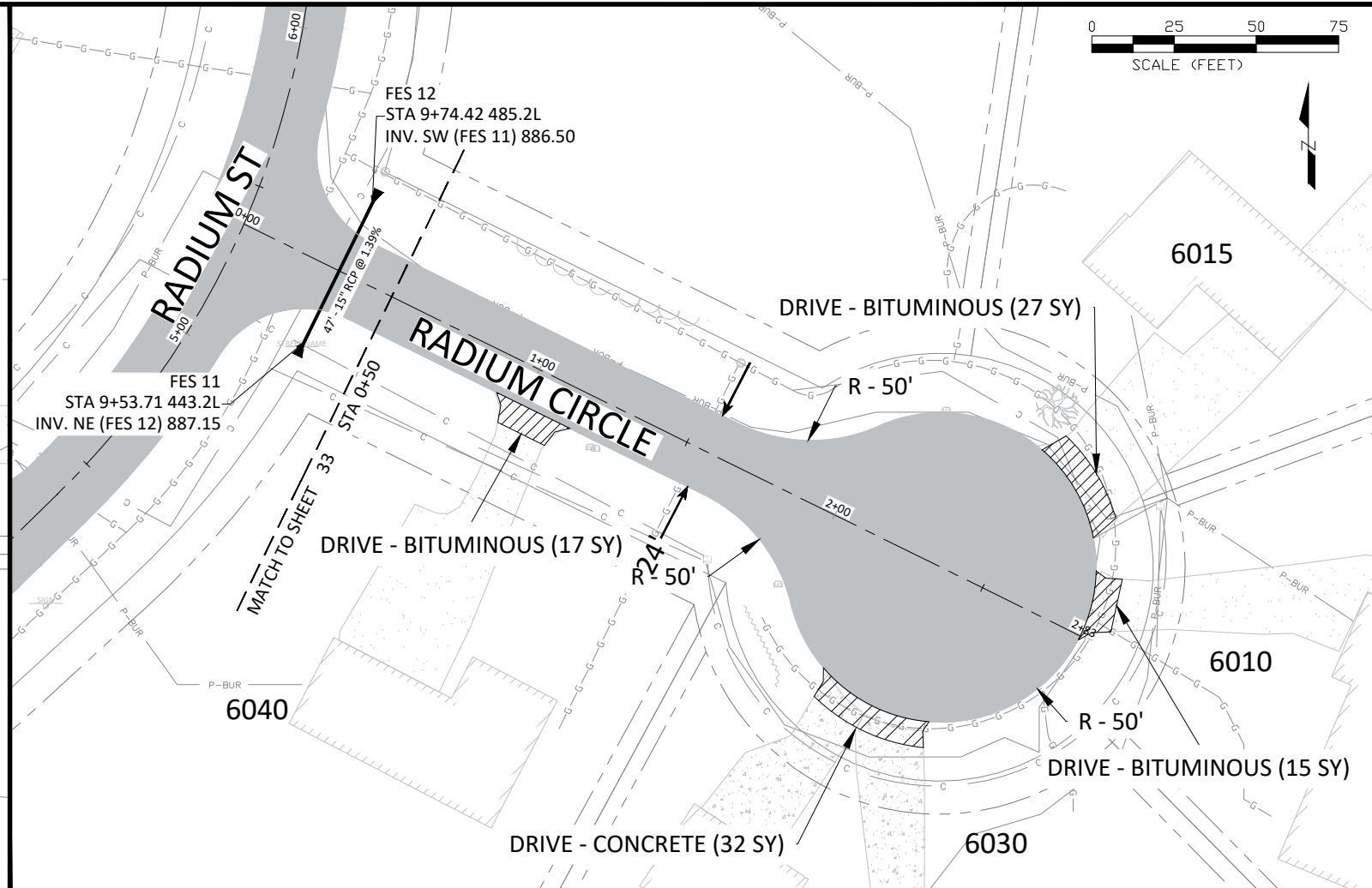
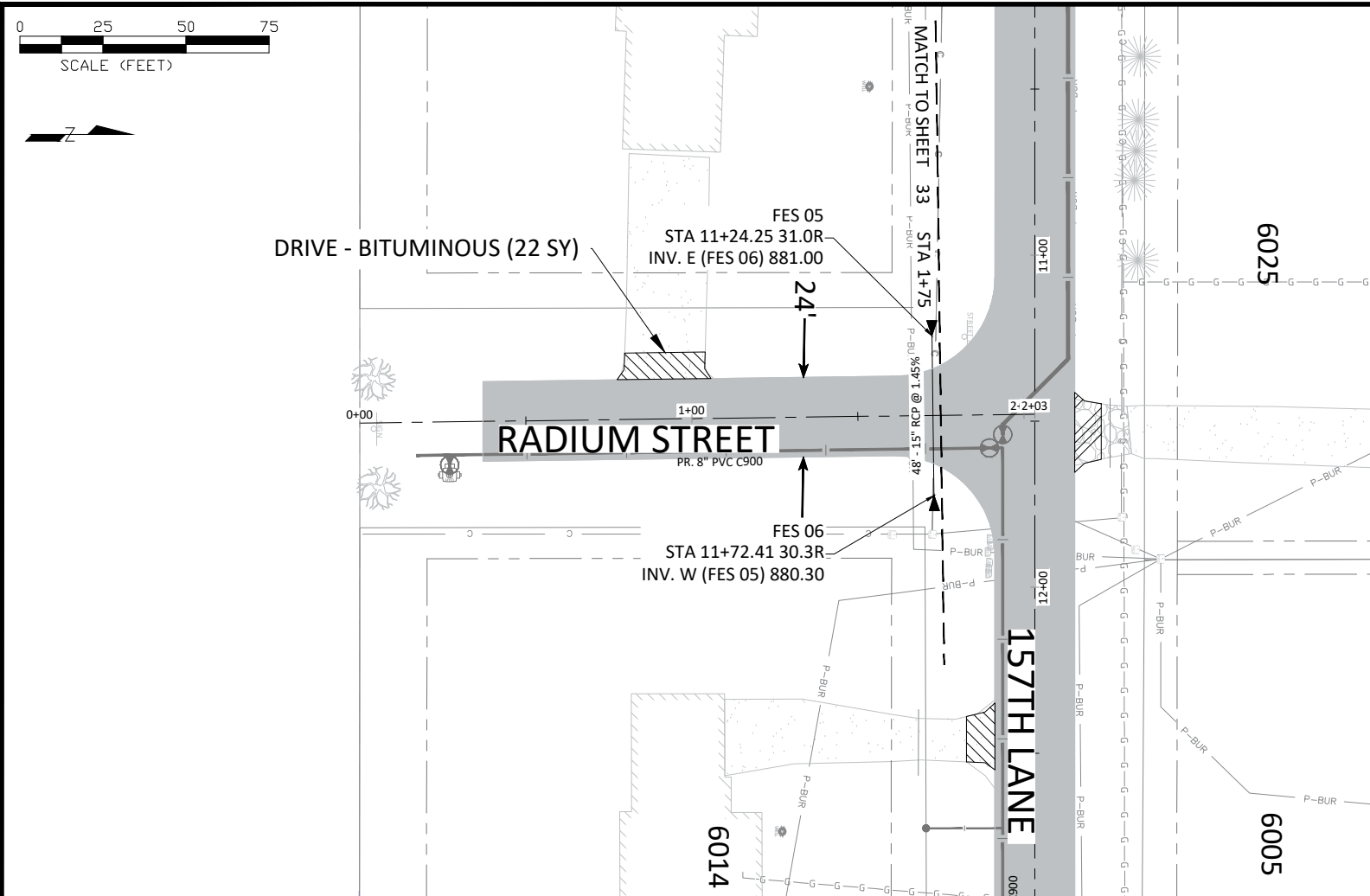

LEGEND

	CONSTRUCTION LIMITS		PR. BITUMINOUS PAVEMENT - ROADWAY		PR. DRIVE - BITUMINOUS
	DRAINAGE & UTILITY EASEMENT LINE		PR. BITUMINOUS PAVEMENT - COUNTY		PR. DRIVE - CONCRETE
	RIGHT OF WAY LINE		PR. BITUMINOUS PAVEMENT - TRAIL		PR. DRIVE - CLASS 5 SURFACE
			PR. 6" CONCRETE WALK		

GENERAL NOTES:

1. ALL RADII TO BE CONSTRUCTED AT 30', UNLESS OTHERWISE NOTED.
2. TYPICAL SECTIONS SEE SHEET 04.
3. PEDESTRIAN RAMP DETAILS SEE SHEETS 09 - 14 .
4. PIPE LENGTH DOES NOT INCLUDE FLARED ENDS. FLARED END INVERTS MEASURED AT PIPE, NOT END OF FLARE.

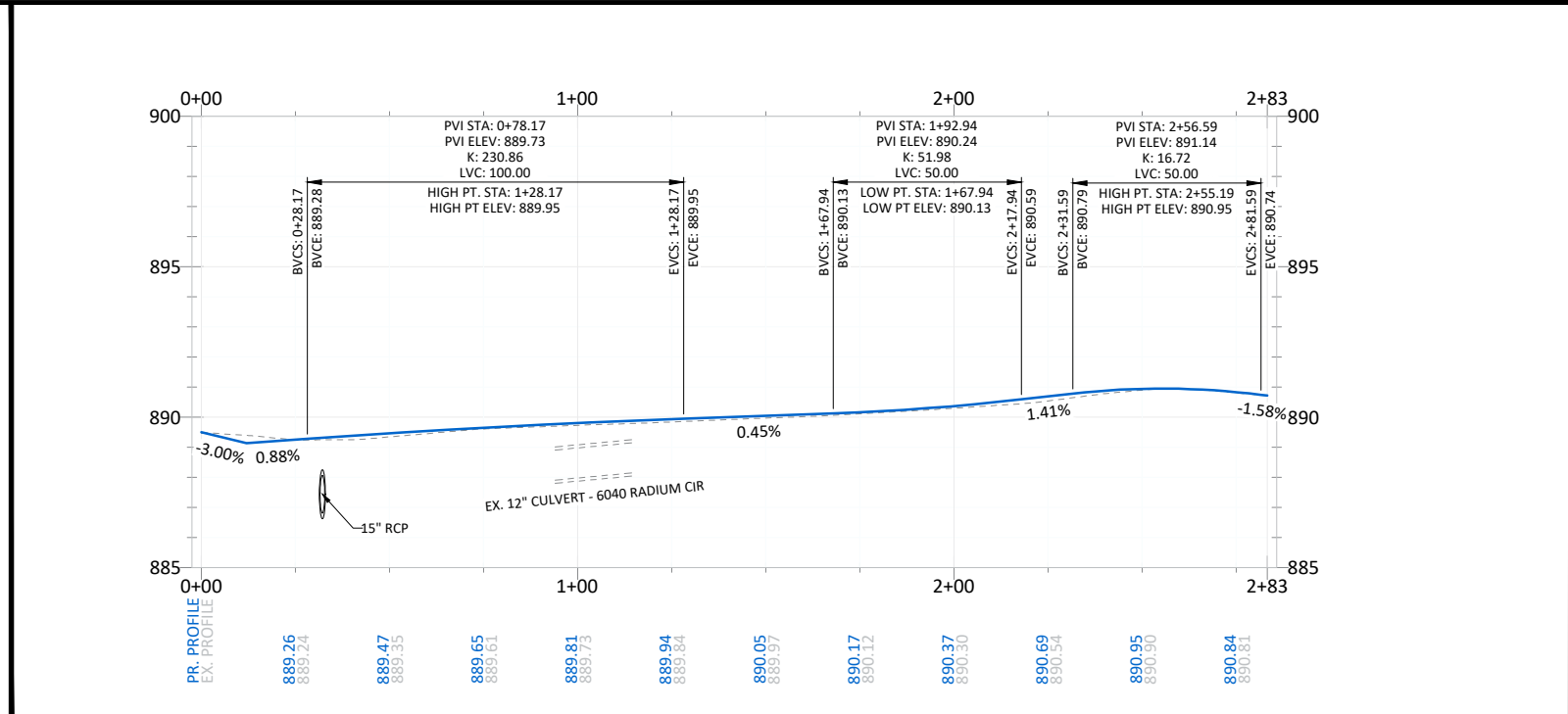
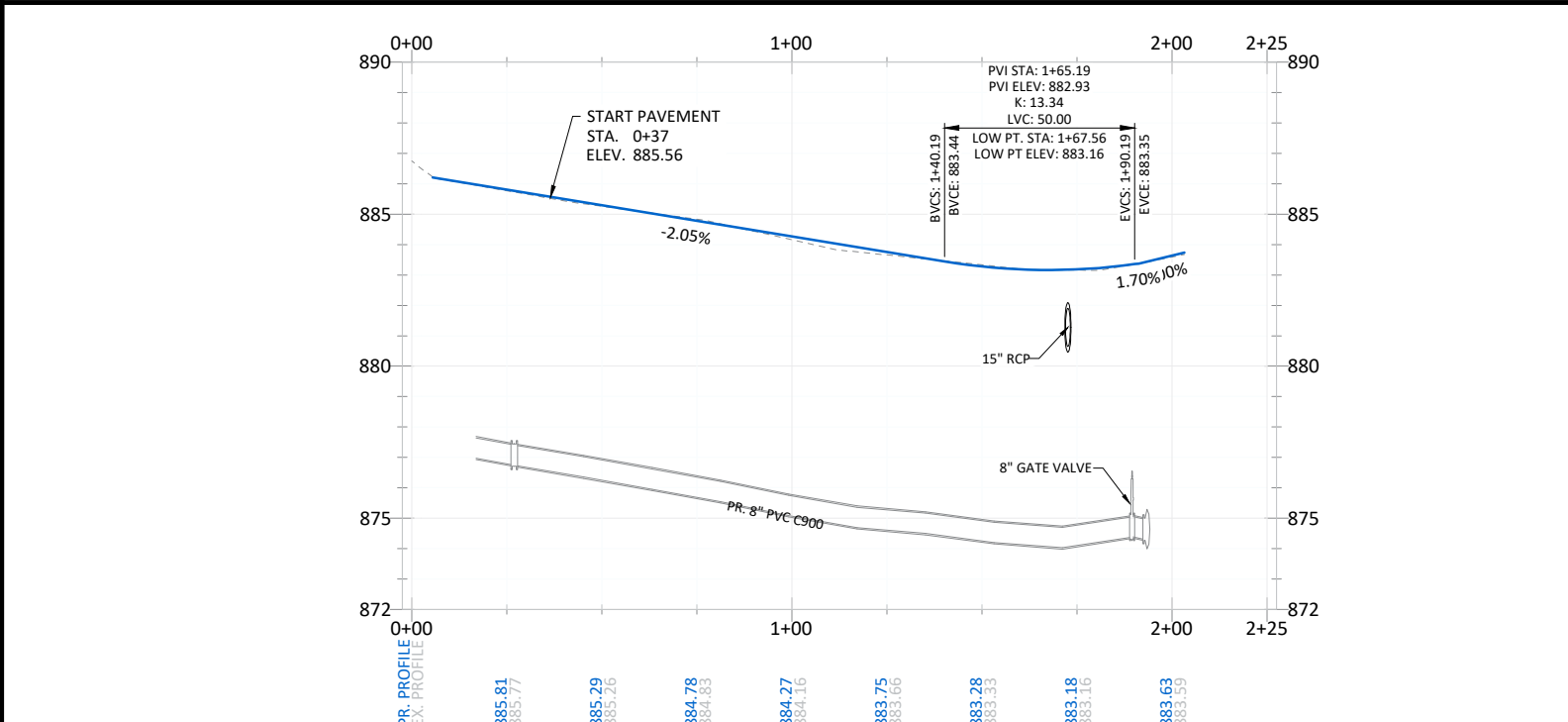

DATE	REVISION
3/28/24	ADD 1" WATER SERVICE - 6014 157TH LN.

I hereby certify that this plan, specification, or report was prepared by me or under my direct supervision and that I am a duly Licensed Professional Engineer Under the laws of the State of Minnesota

Joe Feriancek
 JOE FERIANCEK
 Date: 4/23/24 Lic. No. 57095

DESIGNED BY: J JF
 DATE: 12/15/23
 DRAWN BY: J JF
 FILE: 24-02
 CHECKED BY: BRW

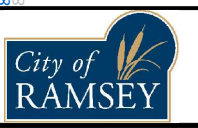

CITY OF RAMSEY
 7550 SUNWOOD DRIVE
 RAMSEY, MN 55303
 (763) 427-1410 FAX (763) 433-9898

STREET & STORM SEWER

HALLS DOVER ACRES STREET RECONSTRUCTIONS
 CITY PROJECT NO. 24-02
 CITY OF RAMSEY, MINNESOTA

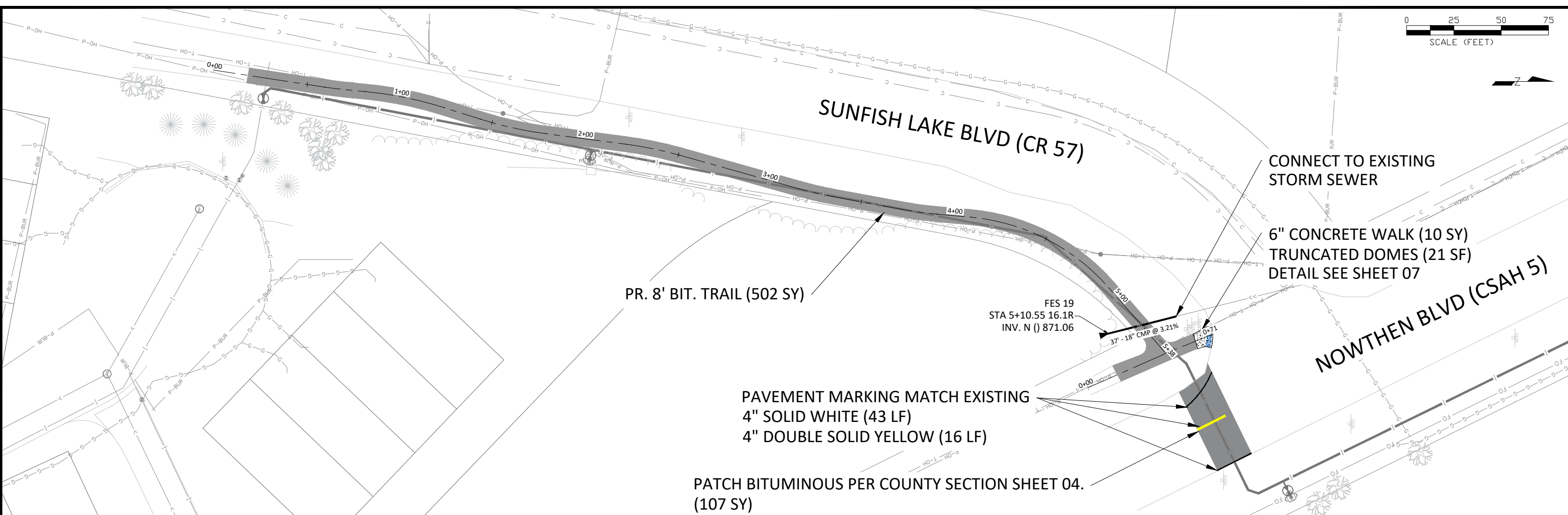
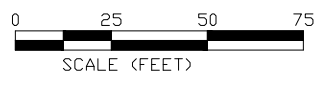

LEGEND

	CONSTRUCTION LIMITS
	DRAINAGE & UTILITY EASEMENT LINE
	RIGHT OF WAY LINE

	PR. BITUMINOUS PAVEMENT - ROADWAY
	PR. BITUMINOUS PAVEMENT - COUNTY
	PR. BITUMINOUS PAVEMENT - TRAIL
	PR. 6" CONCRETE WALK

	PR. DRIVE - BITUMINOUS
	PR. DRIVE - CONCRETE
	PR. DRIVE - CLASS 5 SURFACE

	HYDRANT
	WATER VALVE
	WATERMAIN
	PR. STORM SEWER
	PR. FLARED END SECTION

GENERAL NOTES:

1. ALL RADII TO BE CONSTRUCTED AT 30', UNLESS OTHERWISE NOTED.
2. TYPICAL SECTIONS SEE SHEET 04.
3. PEDESTRIAN RAMP DETAILS SEE SHEETS 09 - 14 .
4. PIPE LENGTH DOES NOT INCLUDE FLARED ENDS. FLARED END INVERTS MEASURED AT PIPE, NOT END OF FLARE.

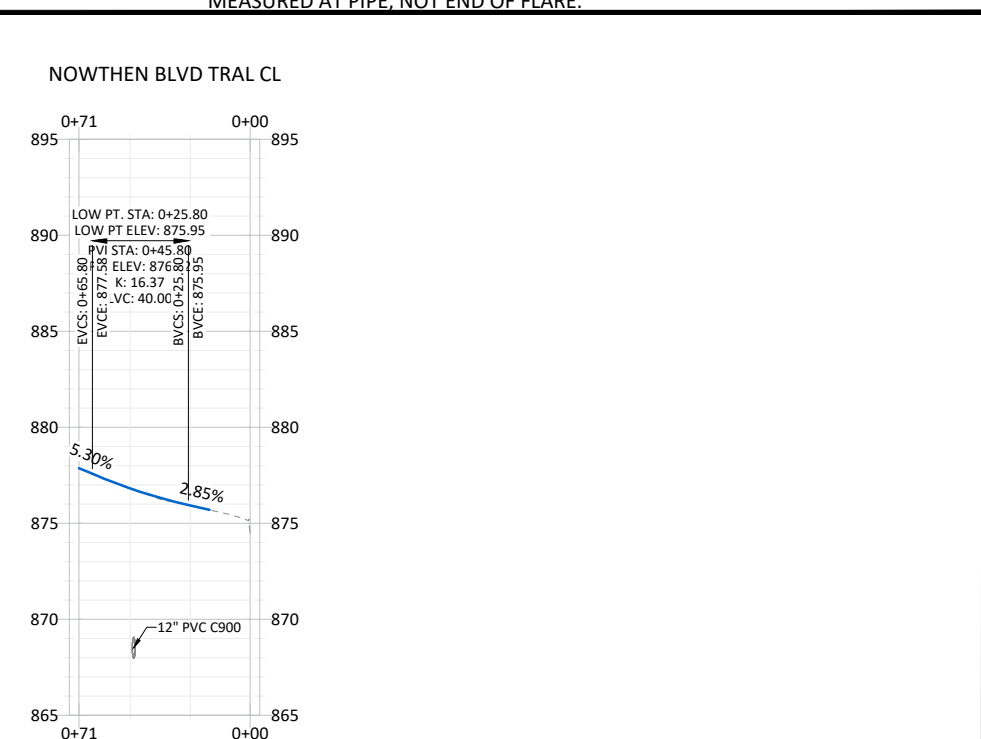
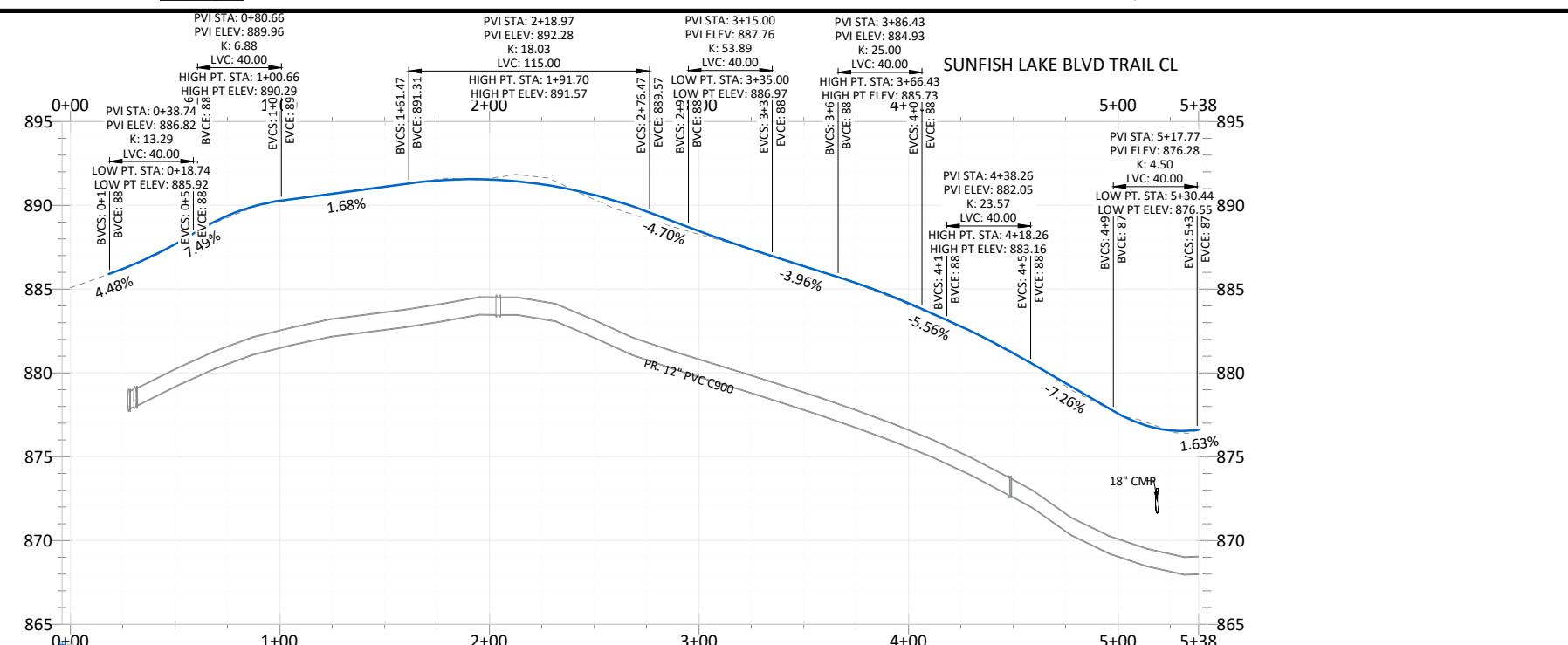

DATE	REVISION

I hereby certify that this plan, specification, or report was prepared by me or under my direct supervision and that I am a duly Licensed Professional Engineer Under the laws of the State of Minnesota

Joe Feriancek
 JOE FERIANCEK
 Date: 1/23/24 Lic. No. 57095

DESIGNED BY:	JJF
DRAWN BY:	JJF
CHECKED BY:	BRW

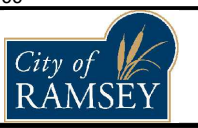

CITY OF RAMSEY
 7550 SUNWOOD DRIVE
 RAMSEY, MN 55303
 (763) 427-1410 FAX (763) 433-9898

SUNFISH LAKE TRAIL & STORM SEWER

HALLS DOVER ACRES STREET RECONSTRUCTIONS
 CITY PROJECT NO. 24-02
 CITY OF RAMSEY, MINNESOTA

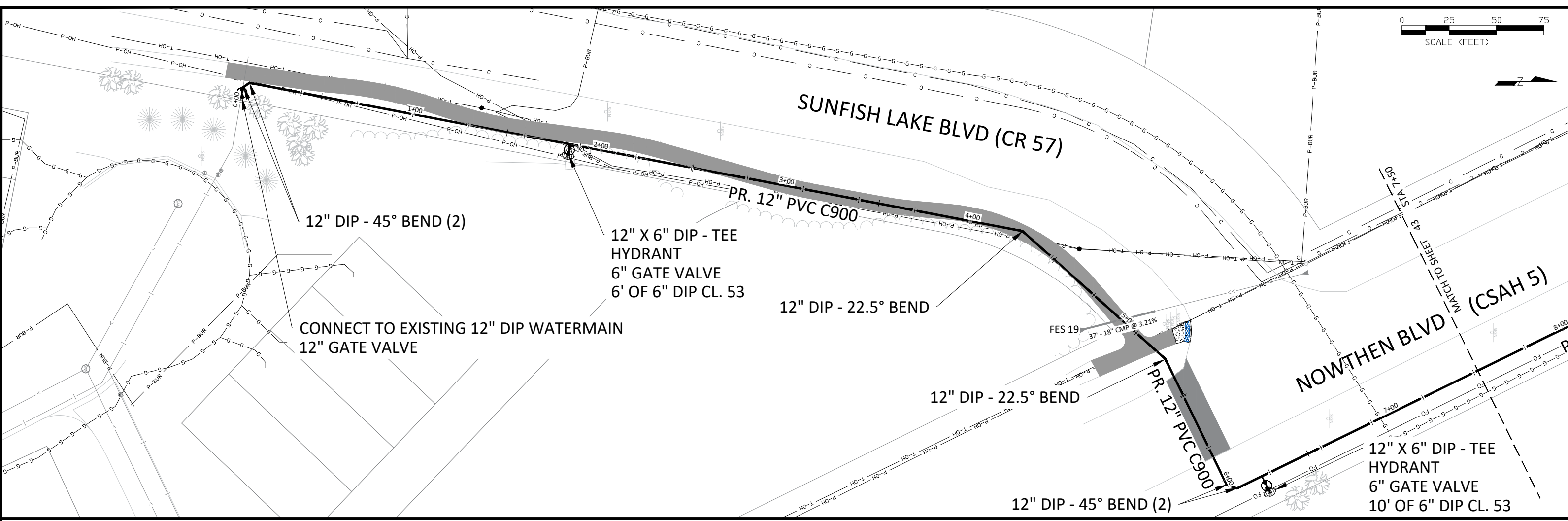
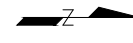
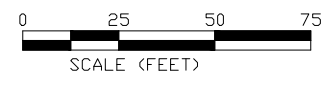

12" DIP - 45° BEND (2)

12" X 6" DIP - TEE
HYDRANT
6" GATE VALVE
6' OF 6" DIP CL. 53

CONNECT TO EXISTING 12" DIP WATERMAIN
12" GATE VALVE

12" DIP - 22.5° BEND

12" DIP - 22.5° BEND

12" DIP - 45° BEND (2)

12" X 6" DIP - TEE
HYDRANT
6" GATE VALVE
10' OF 6" DIP CL. 53

LEGEND

- CONSTRUCTION LIMITS
- - - DRAINAGE & UTILITY EASEMENT LINE
- RIGHT OF WAY LINE

- PR. BITUMINOUS PAVEMENT - ROADWAY
- PR. BITUMINOUS PAVEMENT - COUNTY
- PR. BITUMINOUS PAVEMENT - TRAIL
- PR. 6" CONCRETE WALK

- PR. DRIVE - BITUMINOUS
- PR. DRIVE - CONCRETE
- PR. DRIVE - CLASS 5 SURFACE

- HYDRANT
- WATER VALVE
- WATERMAIN
- PR. STORM SEWER
- PR. FLARED END SECTION

- GENERAL NOTES:**
1. WATERMAIN 8" OR LARGER SHALL BE PVC C900.
 2. WATERMAIN 6" OR SMALLER SHALL BE CLASS 53.
 3. MINIMUM 7.5' OF COVER OVER ALL WATERMAIN.

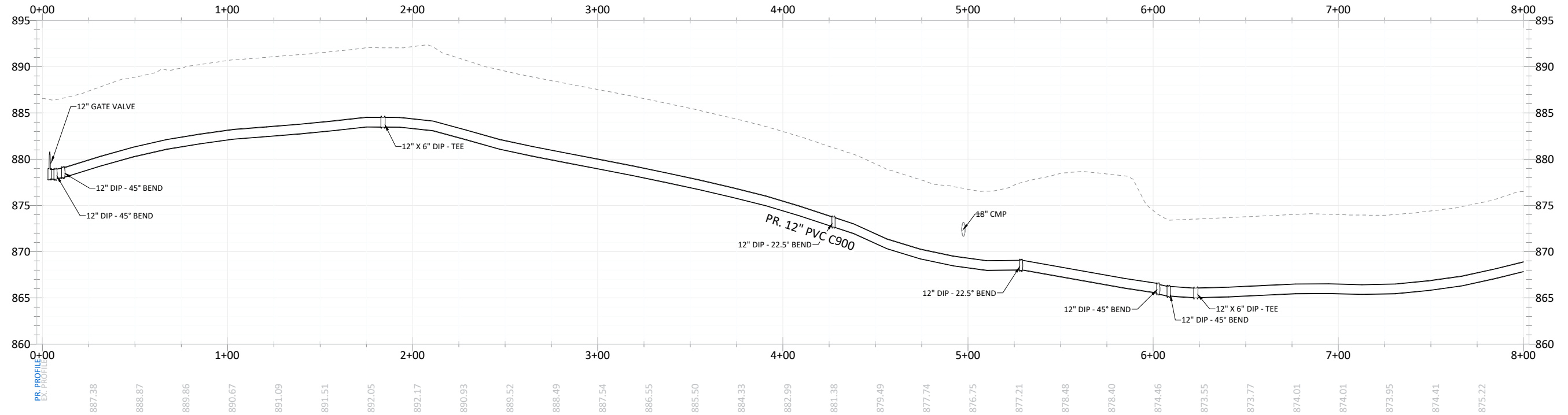
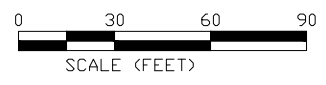

DATE	REVISION

I hereby certify that this plan, specification, or report was prepared by me or under my direct supervision and that I am a duly Licensed Professional Engineer Under the laws of the State of Minnesota

Joe Feriancek
JOE FERIANCEK
Date: 1/23/24 Lic. No. 57095

DESIGNED BY: JJF
DRAWN BY: JJF
CHECKED BY: BRW

DATE: 12/15/23
FILE: 24-02

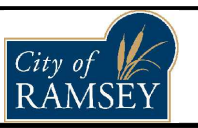

CITY OF RAMSEY
7550 SUNWOOD DRIVE
RAMSEY, MN 55303
(763) 427-1410 FAX (763) 433-9898

WATERMAIN CONSTRUCTION

HALLS DOVER ACRES STREET RECONSTRUCTIONS
CITY PROJECT NO. 24-02
CITY OF RAMSEY, MINNESOTA

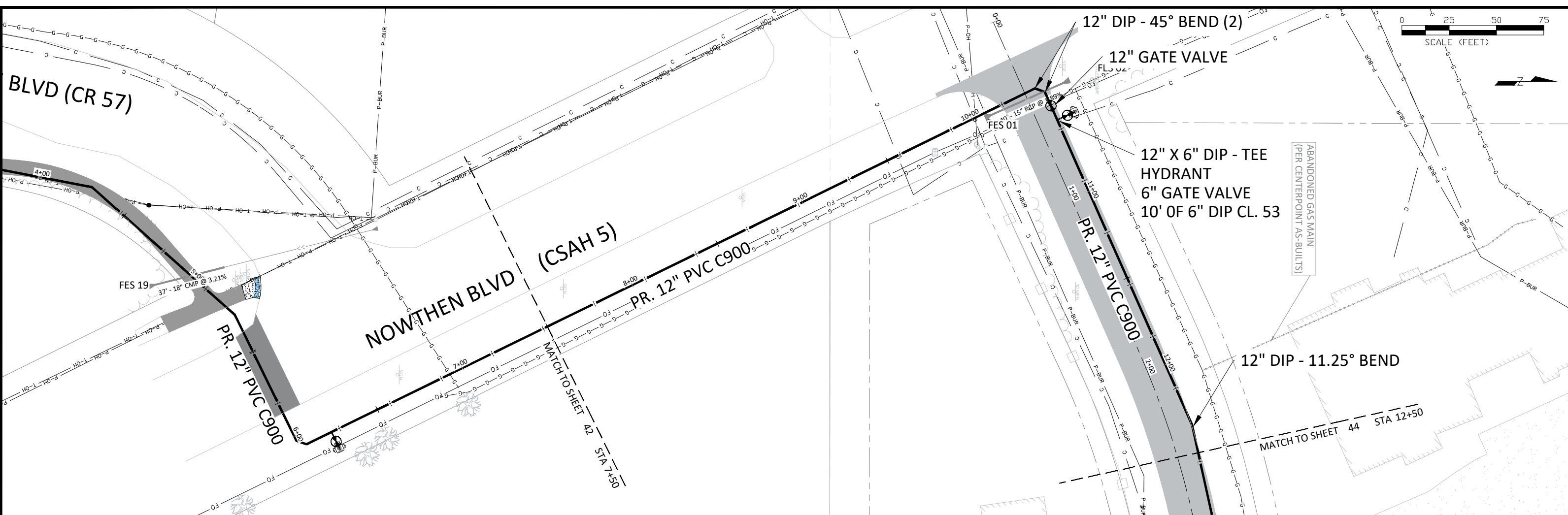

LEGEND

- CONSTRUCTION LIMITS
- - - DRAINAGE & UTILITY EASEMENT LINE
- RIGHT OF WAY LINE

- PR. BITUMINOUS PAVEMENT - ROADWAY
- PR. BITUMINOUS PAVEMENT - COUNTY
- PR. BITUMINOUS PAVEMENT - TRAIL
- PR. 6" CONCRETE WALK

- PR. DRIVE - BITUMINOUS
- PR. DRIVE - CONCRETE
- PR. DRIVE - CLASS 5 SURFACE

- HYDRANT
- WATER VALVE
- WATERMAIN
- PR. STORM SEWER
- PR. FLARED END SECTION

- GENERAL NOTES:**
1. WATERMAIN 8" OR LARGER SHALL BE PVC C900.
 2. WATERMAIN 6" OR SMALLER SHALL BE CLASS 53.
 3. MINIMUM 7.5' OF COVER OVER ALL WATERMAIN.

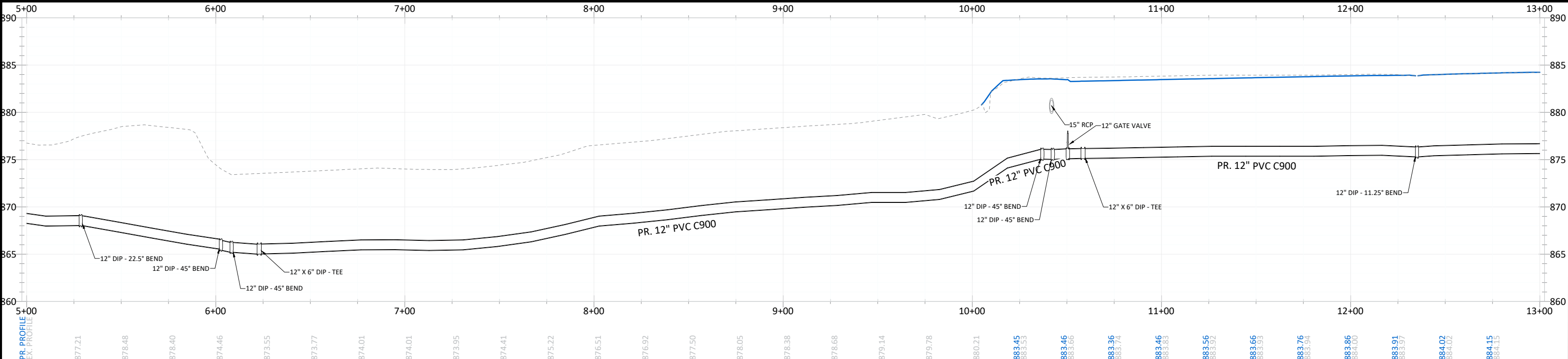

DATE	REVISION

I hereby certify that this plan, specification, or report was prepared by me or under my direct supervision and that I am a duly Licensed Professional Engineer Under the laws of the State of Minnesota

Joe Feriancek
 JOE FERIANCEK
 Date 1/23/24 Lic. No. 57095

DESIGNED BY: JJF
 DRAWN BY: JJF
 CHECKED BY: BRW

DATE: 12/15/23
 FILE: 24-02

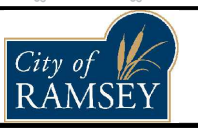

CITY OF RAMSEY
 7550 SUNWOOD DRIVE
 RAMSEY, MN 55303
 (763) 427-1410 FAX (763) 433-9898

WATERMAIN CONSTRUCTION

HALLS DOVER ACRES STREET RECONSTRUCTIONS
 CITY PROJECT NO. 24-02
 CITY OF RAMSEY, MINNESOTA

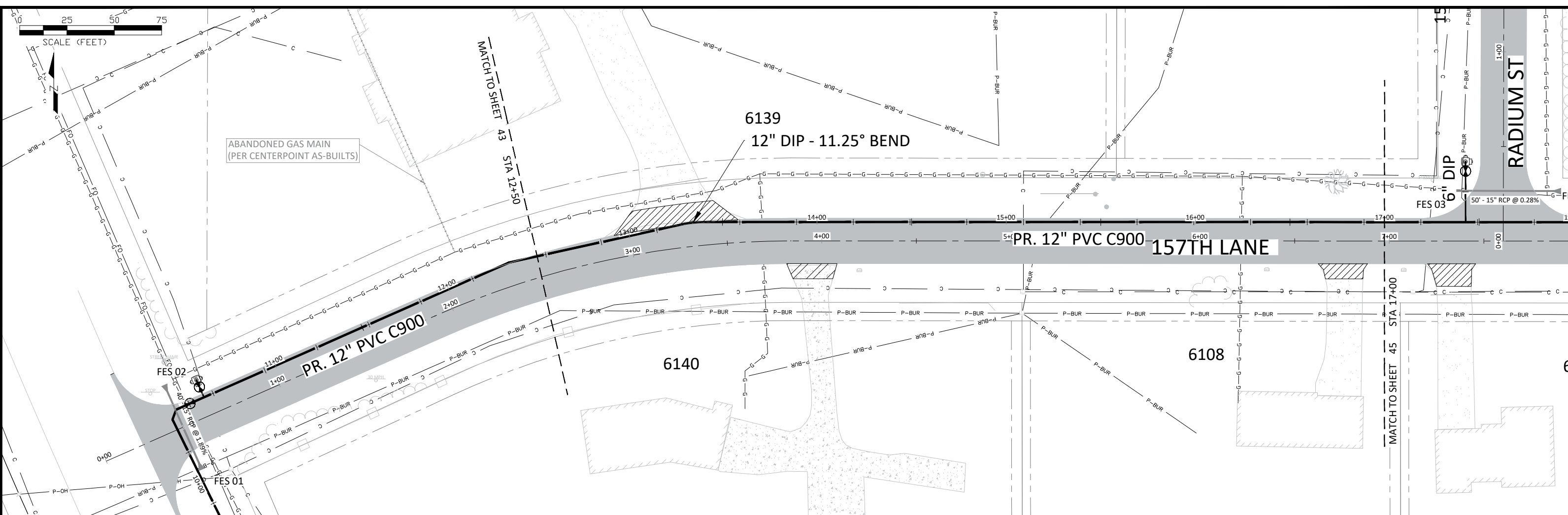

LEGEND		PR. DRIVE - BITUMINOUS		HYDRANT		GENERAL NOTES:
---	CONSTRUCTION LIMITS	[Hatched Box]	PR. DRIVE - BITUMINOUS	[Symbol]	HYDRANT	
---	DRAINAGE & UTILITY EASEMENT LINE	[Hatched Box]	PR. DRIVE - CONCRETE	[Symbol]	WATER VALVE	
---	RIGHT OF WAY LINE	[Hatched Box]	PR. DRIVE - CLASS 5 SURFACE	[Symbol]	PR. STORM SEWER	
[Shaded Box]	PR. BITUMINOUS PAVEMENT - ROADWAY	[Hatched Box]	PR. DRIVE - BITUMINOUS	[Symbol]	PR. FLARED END SECTION	
[Shaded Box]	PR. BITUMINOUS PAVEMENT - COUNTY	[Hatched Box]	PR. DRIVE - CONCRETE	[Symbol]		
[Shaded Box]	PR. BITUMINOUS PAVEMENT - TRAIL	[Hatched Box]	PR. DRIVE - CLASS 5 SURFACE	[Symbol]		
[Shaded Box]	PR. 6" CONCRETE WALK	[Hatched Box]		[Symbol]		

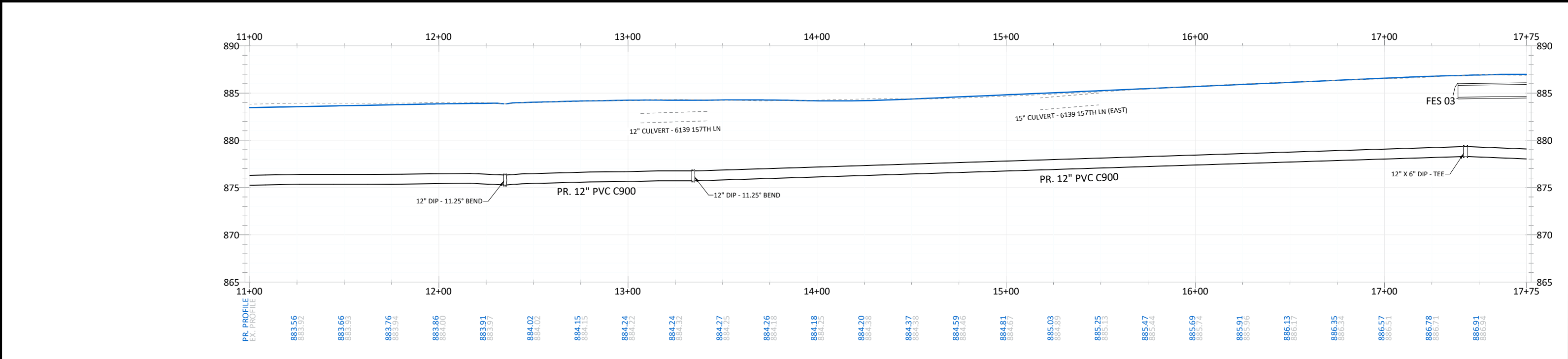

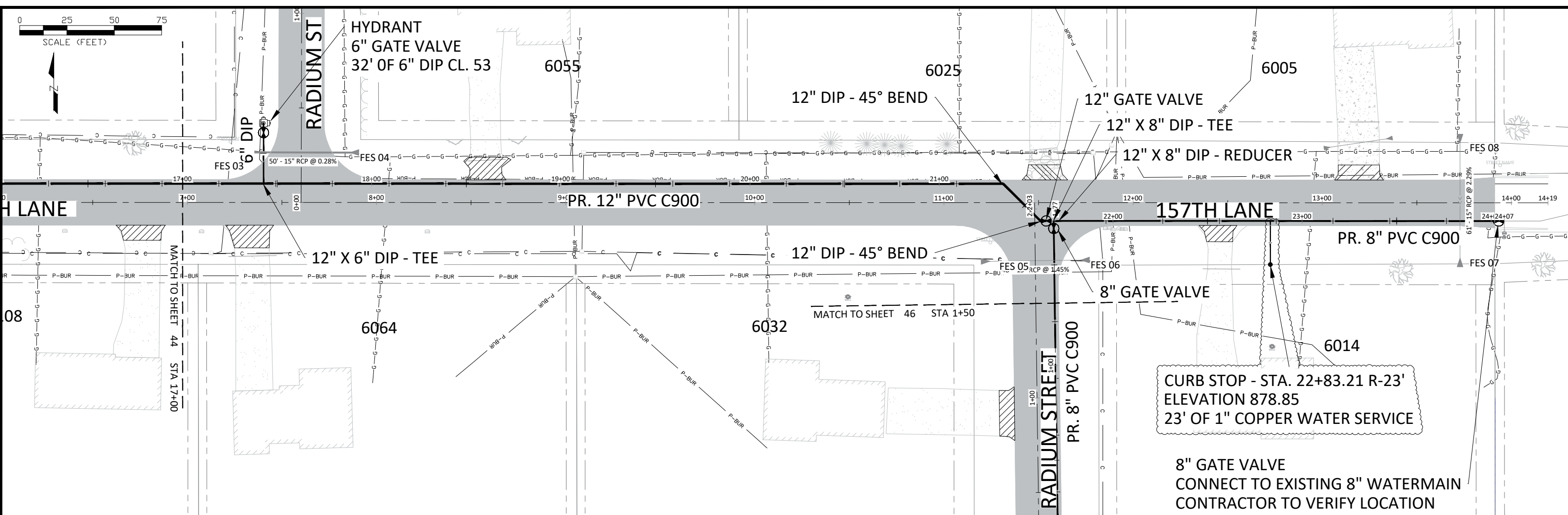

LEGEND

--- CONSTRUCTION LIMITS		PR. BITUMINOUS PAVEMENT - ROADWAY		PR. DRIVE - BITUMINOUS		HYDRANT
--- DRAINAGE & UTILITY EASEMENT LINE		PR. BITUMINOUS PAVEMENT - COUNTY		PR. DRIVE - CONCRETE		WATERMAIN
--- RIGHT OF WAY LINE		PR. BITUMINOUS PAVEMENT - TRAIL		PR. DRIVE - CLASS 5 SURFACE		PR. STORM SEWER
		PR. 6" CONCRETE WALK				PR. FLARED END SECTION

GENERAL NOTES:
 1. WATERMAIN 8" OR LARGER SHALL BE PVC C900.
 2. WATERMAIN 6" OR SMALLER SHALL BE CLASS 53.
 3. MINIMUM 7.5' OF COVER OVER ALL WATERMAIN.

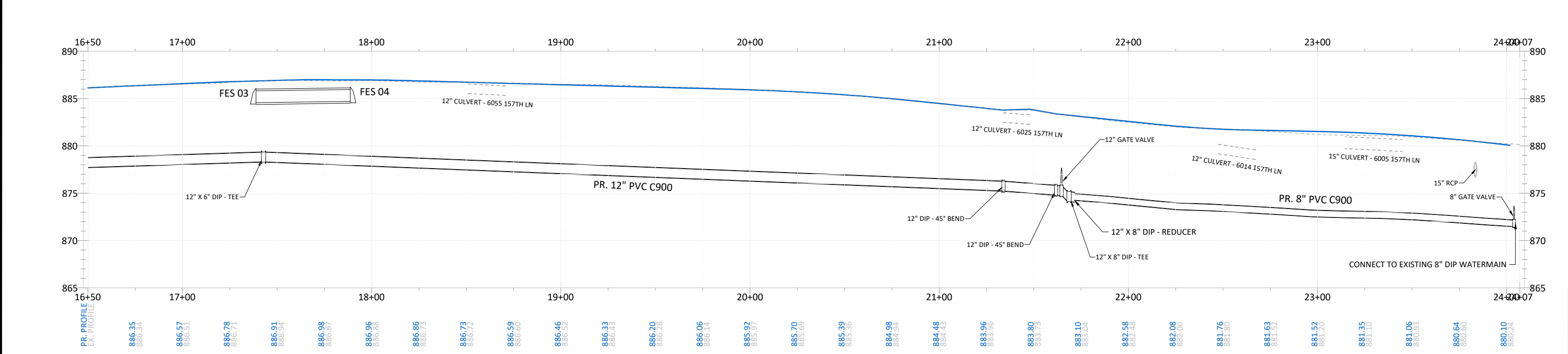

DATE	REVISION
3/28/24	ADD 1" WATER SERVICE - 6014 157TH LN.

I hereby certify that this plan, specification, or report was prepared by me or under my direct supervision and that I am a duly Licensed Professional Engineer Under the laws of the State of Minnesota

Joe Feriancek
 JOE FERIANCEK
 Date: 1/23/24 Lic. No. 57095

DESIGNED BY: JJF
 DRAWN BY: JJF
 CHECKED BY: BRW

DATE: 12/15/23
 FILE: 24-02

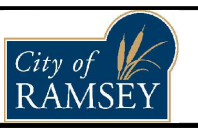

CITY OF RAMSEY
 7550 SUNWOOD DRIVE
 RAMSEY, MN 55303
 (763) 427-1410 FAX (763) 433-9898

WATERMAIN CONSTRUCTION

HALLS DOVER ACRES STREET RECONSTRUCTIONS
 CITY PROJECT NO. 24-02
 CITY OF RAMSEY, MINNESOTA

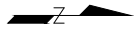

8" PLUG

8" X 6" DIP - TEE
HYDRANT
6" GATE VALVE
6 LF OF 6" DIP CL. 53

RADIUM STREET
PR. 8" PVC C900

157TH LANE

12" X 8" DIP - TEE
8" GATE VALVE

6025

6005

6030

R-50'

LEGEND

- CONSTRUCTION LIMITS
- - - DRAINAGE & UTILITY EASEMENT LINE
- RIGHT OF WAY LINE



- PR. BITUMINOUS PAVEMENT - ROADWAY
- PR. BITUMINOUS PAVEMENT - COUNTY
- PR. BITUMINOUS PAVEMENT - TRAIL
- PR. 6" CONCRETE WALK

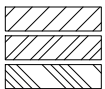

- PR. DRIVE - BITUMINOUS
- PR. DRIVE - CONCRETE
- PR. DRIVE - CLASS 5 SURFACE



- HYDRANT
- WATER VALVE
- WATERMAIN
- PR. STORM SEWER
- PR. FLARED END SECTION

GENERAL NOTES:

1. WATERMAIN 8" OR LARGER SHALL BE PVC C900.
2. WATERMAIN 6" OR SMALLER SHALL BE CLASS 53.
3. MINIMUM 7.5' OF COVER OVER ALL WATERMAIN.

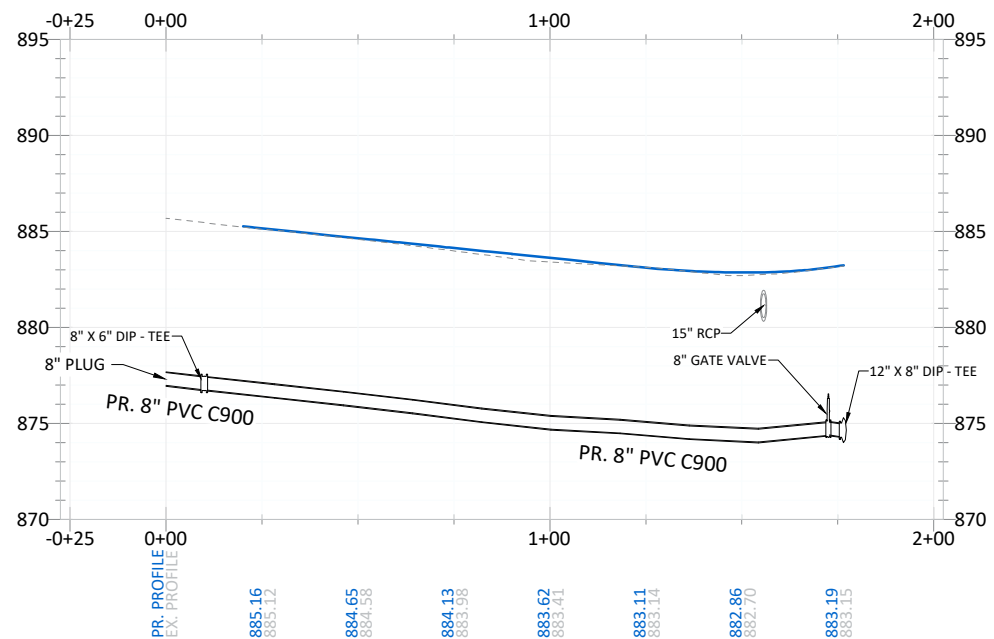

DATE	REVISION
3/28/24	ADD 1" WATER SERVICE - 6014 157TH LN.

I hereby certify that this plan, specification, or report was prepared by me or under my direct supervision and that I am a duly Licensed Professional Engineer Under the laws of the State of Minnesota

Joe Feriancek
JOE FERIANCEK
Date 1/23/24 Lic. No. 57095

DESIGNED BY: JJF
DRAWN BY: JJF
CHECKED BY: BRW

DATE: 12/15/23
FILE: 24-02

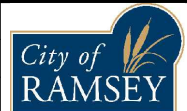

CITY OF RAMSEY
7550 SUNWOOD DRIVE
RAMSEY, MN 55303
(763) 427-1410 FAX (763) 433-9898

WATERMAIN CONSTRUCTION

HALLS DOVER ACRES STREET RECONSTRUCTIONS
CITY PROJECT NO. 24-02
CITY OF RAMSEY, MINNESOTA

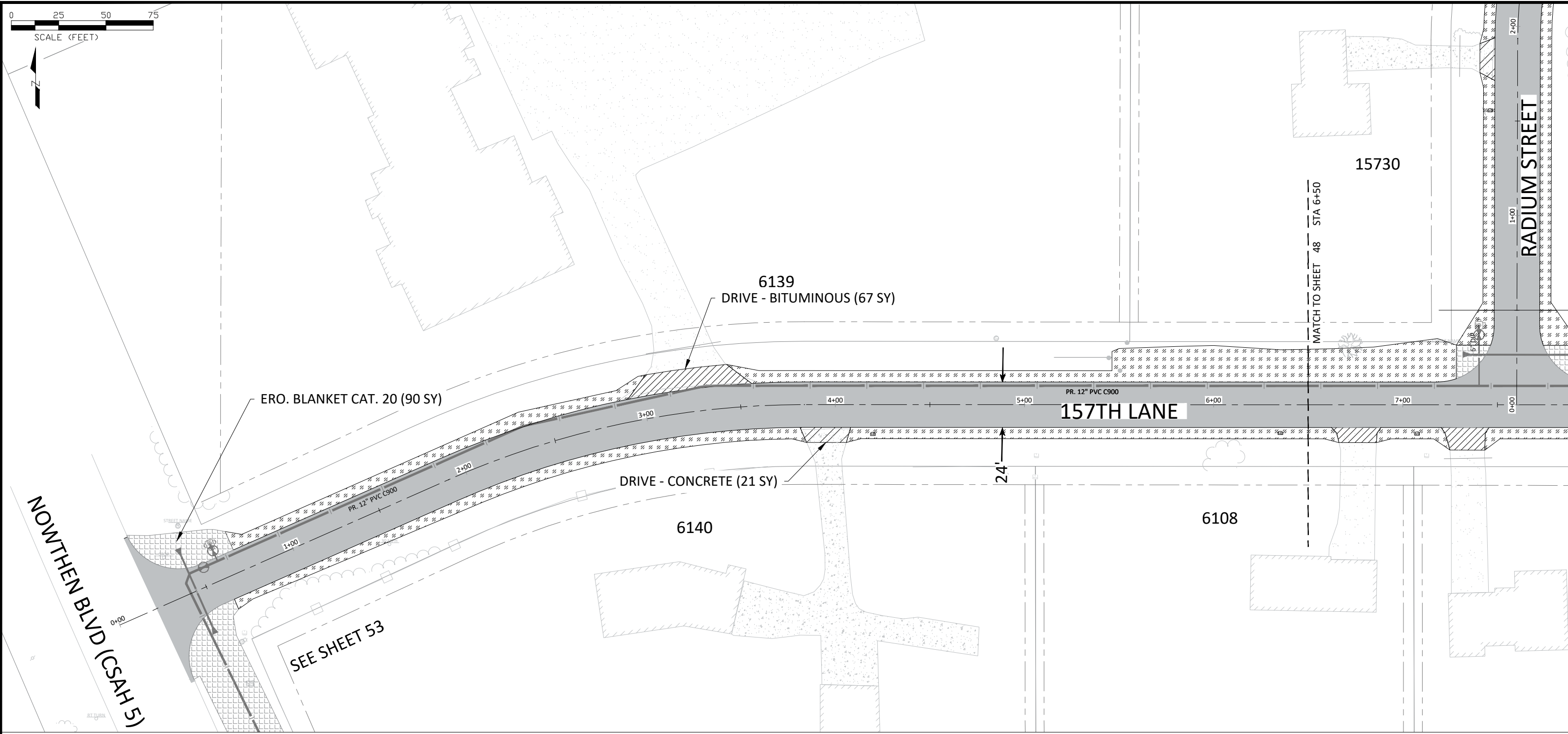

LEGEND

	SEED & MULCH AREA		PR. BITUMINOUS PAVEMENT - ROADWAY
	EROSION CONTROL BLANKET		PR. BITUMINOUS PAVEMENT - COUNTY
	WATERMAIN		PR. BITUMINOUS PAVEMENT - TRAIL
	SANITARY SEWER		PR. DRIVE - BITUMINOUS
	STORM SEWER		PR. DRIVE - CONCRETE
	DRAINAGE & UTILITY EASEMENT		PR. DRIVE - GRAVEL SURFACE
	RIGHT OF WAY LINE		PR. 6" CONCRETE WALK
	SECTION LINE		

NOTE:

- RESTORATION AREAS ARE SHOWN IN A GENERAL MANNER ONLY.
- RESTORE ALL DISTURBED AREAS WITH 4" TOPSOIL, HYDROSEED, MNDOT SEED MIX 25-151, AND HYDRAULIC MATRIX TYPE MULCH UNLESS MARKED FOR EROSION CONTROL BLANKET.
- RESTORE ALL AREAS MARKED FOR EROSION CONTROL BLANKET WITH 4" TOPSOIL, MNDOT SEED MIX 25-141 UNLESS NOTED OTHERWISE, AND ROLLED EROSION PREVENTION CATEGORY 20.
- STOCKPILING OF ANY SALVAGED TOPSOIL USED IS INCIDENTAL TO THE TOPSOIL PAY ITEM.
- CONTRACTOR IS RESPONSIBLE FOR RESTORING ALL LANDSCAPING TO AS GOOD OR BETTER CONDITION. PAYMENT MADE UNDER LANDSCAPE RESTORATION.
- SALVAGED ITEMS ARE TO BE RE-INSTALLED TO ORIGINAL LOCATION(S) OR AS DIRECTED BY THE ENGINEER.

RESTORATION SUMMARY: 157TH LANE STA. 0+00 TO 6+50 PROJECT TOTAL

SEEDING AREA	0.20 AC	SEEDING AREA	2.99 AC
HYDROMULCH (4000 LB/AC)	720 LB	HYDROMULCH	6100 LB
ERO. BLANKET CAT. 20	90 SY	ERO. BLANKET CAT. 20	2234
SEED MIX 25-141 (59 LB/AC)	2 LB	SEED MIX 25-141	24 LB
SEED MIX 25-151 (200 LB/AC)	36 LB	SEED MIX 25-151	322 LB
FERTILIZER TYPE 3 (200 LB/AC)	40 LB	FERTILIZER TYPE 3	398 LB
TOPSOIL	138 CY	TOPSOIL	1394 CY
DRIVE - BITUMINOUS	8 TON	DRIVE - BITUMINOUS	41 TON
DRIVE - CONCRETE	21 SY	DRIVE - CONCRETE	225 SY
DRIVE - GRAVEL SURFACE	0 SY	DRIVE - GRAVEL SURFACE	97 SY

DATE	REVISION

I hereby certify that this plan, specification, or report was prepared by me or under my direct supervision and that I am a duly Licensed Professional Engineer Under the laws of the State of Minnesota

Joe Feriancek
JOE FERIANCEK
 Date 1/23/24 Lic. No. 57095

DESIGNED BY:	JJF
DRAWN BY:	JJF
CHECKED BY:	BRW
DATE:	12/15/23
FILE:	24-02

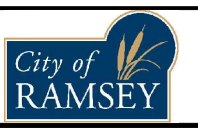

CITY OF RAMSEY
 7550 SUNWOOD DRIVE
 RAMSEY, MN 55303
 (763) 427-1410 FAX (763) 433-9898

RESTORATION

HALLS DOVER ACRES STREET RECONSTRUCTIONS
CITY PROJECT NO. 24-02
 CITY OF RAMSEY, MINNESOTA

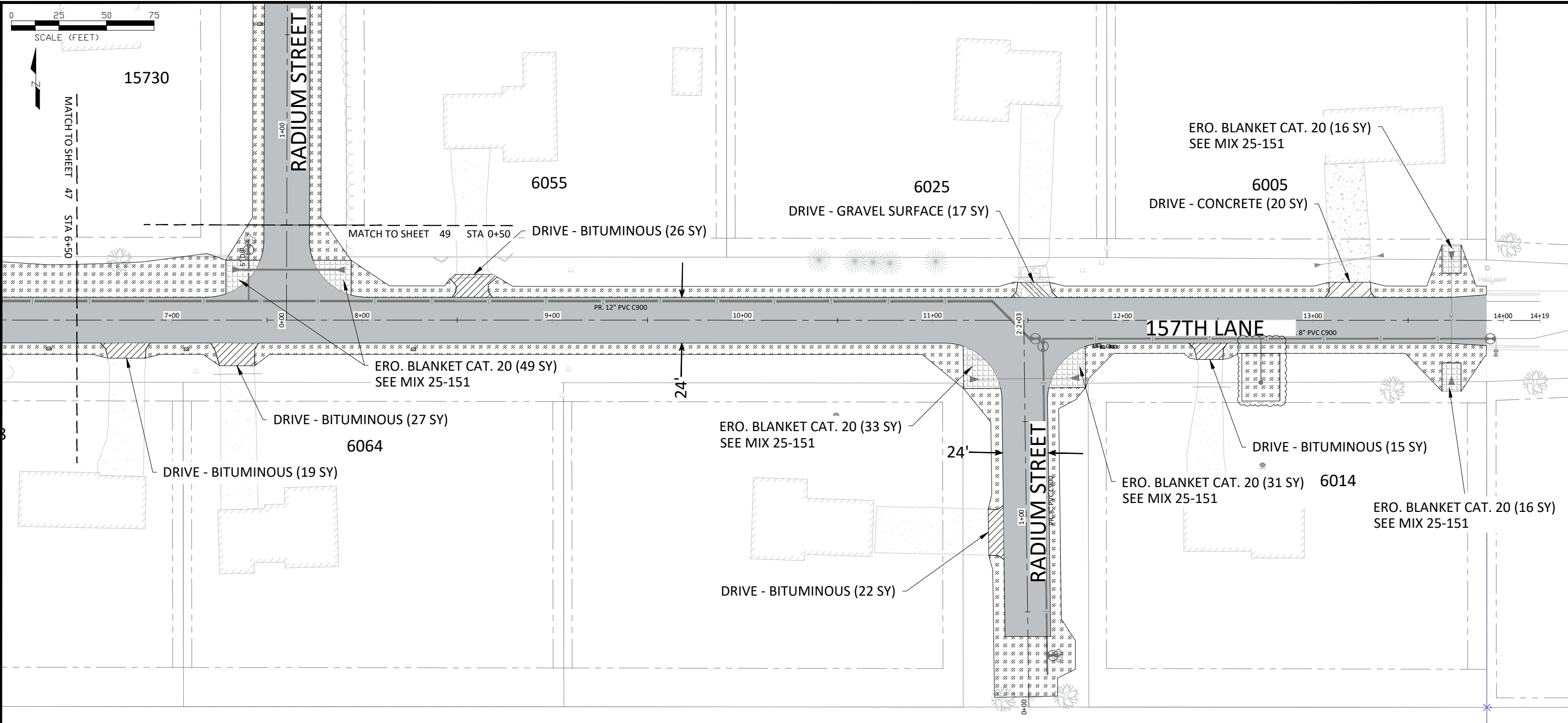

LEGEND

	SEED & MULCH AREA		PR. BITUMINOUS PAVEMENT - ROADWAY
	EROSION CONTROL BLANKET		PR. BITUMINOUS PAVEMENT - COUNTY
	WATERMAIN		PR. BITUMINOUS PAVEMENT - TRAIL
	SANITARY SEWER		PR. DRIVE - BITUMINOUS
	STORM SEWER		PR. DRIVE - CONCRETE
	DRAINAGE & UTILITY EASEMENT		PR. DRIVE - GRAVEL SURFACE
	RIGHT OF WAY LINE		PR. 6" CONCRETE WALK
	SECTION LINE		

NOTE:

1. RESTORATION AREAS ARE SHOWN IN A GENERAL MANNER ONLY.
2. RESTORE ALL DISTURBED AREAS WITH 4" TOPSOIL, HYDROSEED, MNDOT SEED MIX 25-151, AND HYDRAULIC MATRIX TYPE MULCH UNLESS MARKED FOR EROSION CONTROL BLANKET.
3. RESTORE ALL AREAS MARKED FOR EROSION CONTROL BLANKET WITH 4" TOPSOIL, MNDOT SEED MIX 25-141 UNLESS NOTED OTHERWISE, AND ROLLED EROSION PREVENTION CATEGORY 20.
4. STOCKPILING OF ANY SALVAGED TOPSOIL USED IS INCIDENTAL TO THE TOPSOIL PAY ITEM.
5. CONTRACTOR IS RESPONSIBLE FOR RESTORING ALL LANDSCAPING TO AS GOOD OR BETTER CONDITION. PAYMENT MADE UNDER LANDSCAPE RESTORATION.
6. SALVAGED ITEMS ARE TO BE RE-INSTALLED TO ORIGINAL LOCATION(S) OR AS DIRECTED BY THE ENGINEER.

RESTORATION SUMMARY: 157TH LN. STA. 6+50 TO END / RADIUM ST. STUB

SEEDING AREA	0.32 AC
HYDROMULCH (4000 LB/AC)	1180 LB
ERO. BLANKET CAT. 20	145 SY
SEED MIX 25-141 (59 LB/AC)	0 LB
SEED MIX 25-151 (200 LB/AC)	64 LB
FERTILIZER TYPE 3 (200 LB/AC)	64 LB
TOPSOIL	227 CY
DRIVE - BITUMINOUS	13 TON
DRIVE - CONCRETE	20 SY
DRIVE - GRAVEL SURFACE	17 SY

PROJECT TOTAL

SEEDING AREA	2.99 AC
HYDROMULCH	6100 LB
ERO. BLANKET CAT. 20	2234 SY
SEED MIX 25-141	24 LB
SEED MIX 25-151	322 LB
FERTILIZER TYPE 3	398 LB
TOPSOIL	1394 CY
DRIVE - BITUMINOUS	41 TON
DRIVE - CONCRETE	225 SY
DRIVE - GRAVEL SURFACE	97 SY

DATE	REVISION
3/28/24	ADD 1" WATER SERVICE - 6014 157TH LN.

I hereby certify that this plan, specification, or report was prepared by me or under my direct supervision and that I am a duly Licensed Professional Engineer Under the laws of the State of Minnesota

Joe Feriancek
 JOE FERIANCEK
 Date: 1/23/24 Lic. No. 57095

DESIGNED BY:	JJF
DRAWN BY:	JJF
CHECKED BY:	BRW
DATE:	12/15/23
FILE:	24-02

CITY OF RAMSEY
 7550 SUNWOOD DRIVE
 RAMSEY, MN 55303
 (763) 427-1410 FAX (763) 433-9898

RESTORATION

HALLS DOVER ACRES STREET RECONSTRUCTIONS
 CITY PROJECT NO. 24-02
 CITY OF RAMSEY, MINNESOTA

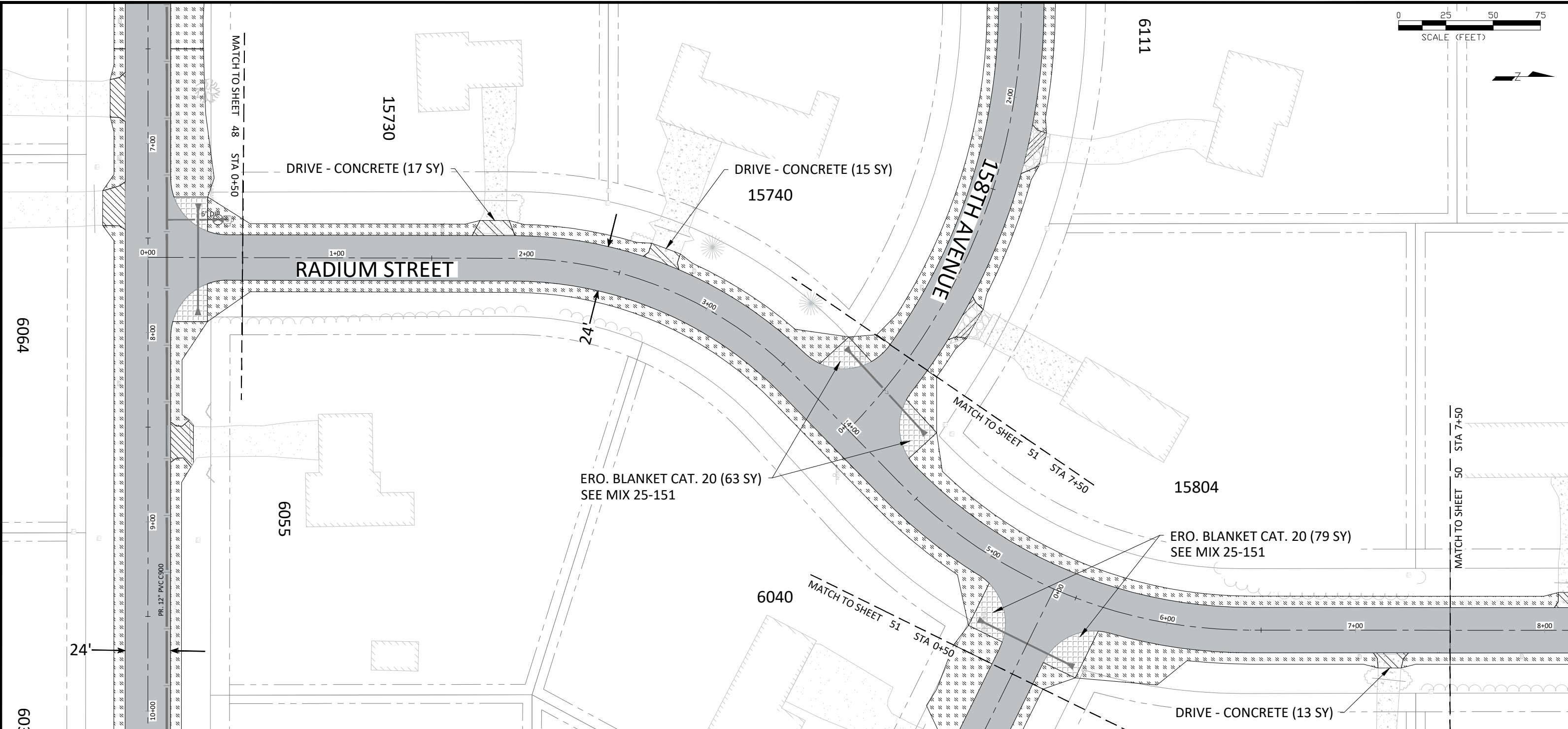

LEGEND

	SEED & MULCH AREA		PR. BITUMINOUS PAVEMENT - ROADWAY
	EROSION CONTROL BLANKET		PR. BITUMINOUS PAVEMENT - COUNTY
	WATERMAIN		PR. BITUMINOUS PAVEMENT - TRAIL
	SANITARY SEWER		PR. DRIVE - BITUMINOUS
	STORM SEWER		PR. DRIVE - CONCRETE
	DRAINAGE & UTILITY EASEMENT		PR. DRIVE - GRAVEL SURFACE
	RIGHT OF WAY LINE		PR. 6" CONCRETE WALK
	SECTION LINE		

NOTE:

1. RESTORATION AREAS ARE SHOWN IN A GENERAL MANNER ONLY.
2. RESTORE ALL DISTURBED AREAS WITH 4" TOPSOIL, HYDROSEED, MNDOT SEED MIX 25-151, AND HYDRAULIC MATRIX TYPE MULCH UNLESS MARKED FOR EROSION CONTROL BLANKET.
3. RESTORE ALL AREAS MARKED FOR EROSION CONTROL BLANKET WITH 4" TOPSOIL, MNDOT SEED MIX 25-141 UNLESS NOTED OTHERWISE, AND ROLLED EROSION PREVENTION CATEGORY 20.
4. STOCKPILING OF ANY SALVAGED TOPSOIL USED IS INCIDENTAL TO THE TOPSOIL PAY ITEM.
5. CONTRACTOR IS RESPONSIBLE FOR RESTORING ALL LANDSCAPING TO AS GOOD OR BETTER CONDITION. PAYMENT MADE UNDER LANDSCAPE RESTORATION.
6. SALVAGED ITEMS ARE TO BE RE-INSTALLED TO ORIGINAL LOCATION(S) OR AS DIRECTED BY THE ENGINEER.

RESTORATION SUMMARY: RADIUM ST. STA. 0+00 TO 7+50		PROJECT TOTAL	
SEEDING AREA	0.25 AC	SEEDING AREA	2.99 AC
HYDROMULCH (4000 LB/AC)	880 LB	HYDROMULCH	6100 LB
ERO. BLANKET CAT. 20	142 SY	ERO. BLANKET CAT. 20	2234 SY
SEED MIX 25-141 (59 LB/AC)	0 LB	SEED MIX 25-141	24 LB
SEED MIX 25-151 (200 LB/AC)	50 LB	SEED MIX 25-151	322 LB
FERTILIZER TYPE 3 (200 LB/AC)	50 LB	FERTILIZER TYPE 3	398 LB
TOPSOIL	176 CY	TOPSOIL	1394 CY
DRIVE - BITUMINOUS	0 TON	DRIVE - BITUMINOUS	41 TON
DRIVE - CONCRETE	45 SY	DRIVE - CONCRETE	225 SY
DRIVE - GRAVEL SURFACE	0 SY	DRIVE - GRAVEL SURFACE	97 SY

DATE	REVISION

I hereby certify that this plan, specification, or report was prepared by me or under my direct supervision and that I am a duly Licensed Professional Engineer Under the laws of the State of Minnesota.

Joe Feriancek
JOE FERIANCEK
Date: 1/23/24 Lic. No. 57095

DESIGNED BY:	JJF
DRAWN BY:	JJF
CHECKED BY:	BRW
DATE:	12/15/23
FILE:	24-02

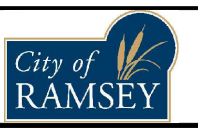

CITY OF RAMSEY
7550 SUNWOOD DRIVE
RAMSEY, MN 55303
(763) 427-1410 FAX (763) 433-9898

RESTORATION

HALLS DOVER ACRES STREET RECONSTRUCTIONS
CITY PROJECT NO. 24-02
CITY OF RAMSEY, MINNESOTA

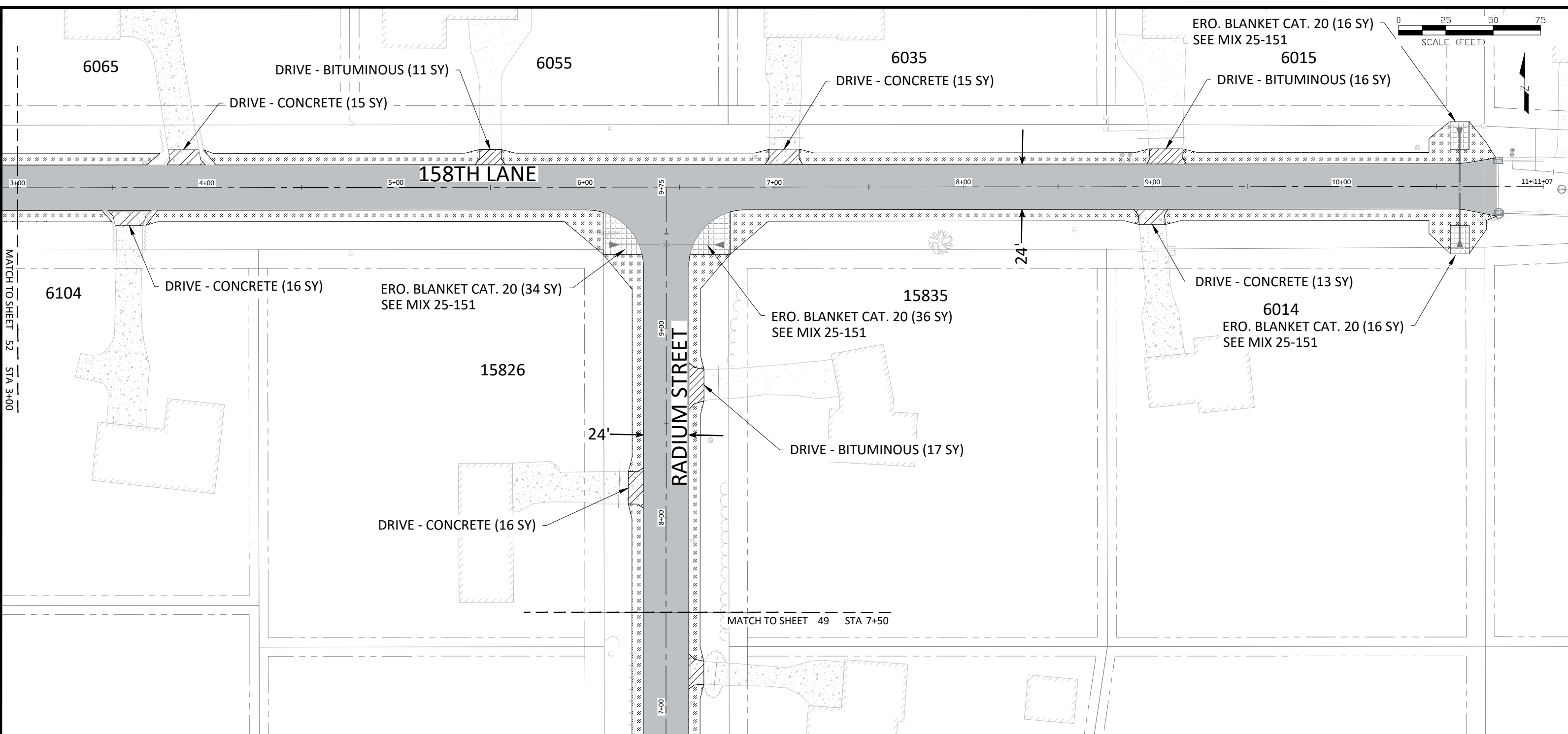

LEGEND

	SEED & MULCH AREA		PR. BITUMINOUS PAVEMENT - ROADWAY
	EROSION CONTROL BLANKET		PR. BITUMINOUS PAVEMENT - COUNTY
	WATERMAIN		PR. BITUMINOUS PAVEMENT - TRAIL
	SANITARY SEWER		PR. DRIVE - BITUMINOUS
	STORM SEWER		PR. DRIVE - CONCRETE
	DRAINAGE & UTILITY EASEMENT		PR. DRIVE - GRAVEL SURFACE
	RIGHT OF WAY LINE		PR. 6" CONCRETE WALK
	SECTION LINE		

NOTE:

- RESTORATION AREAS ARE SHOWN IN A GENERAL MANNER ONLY.
- RESTORE ALL DISTURBED AREAS WITH 4" TOPSOIL, HYDROSEED, MNDOT SEED MIX 25-151, AND HYDRAULIC MATRIX TYPE MULCH UNLESS MARKED FOR EROSION CONTROL BLANKET.
- RESTORE ALL AREAS MARKED FOR EROSION CONTROL BLANKET WITH 4" TOPSOIL, MNDOT SEED MIX 25-141 UNLESS NOTED OTHERWISE, AND ROLLED EROSION PREVENTION CATEGORY 20.
- STOCKPILING OF ANY SALVAGED TOPSOIL USED IS INCIDENTAL TO THE TOPSOIL PAY ITEM.
- CONTRACTOR IS RESPONSIBLE FOR RESTORING ALL LANDSCAPING TO AS GOOD OR BETTER CONDITION. PAYMENT MADE UNDER LANDSCAPE RESTORATION.
- SALVAGED ITEMS ARE TO BE RE-INSTALLED TO ORIGINAL LOCATION(S) OR AS DIRECTED BY THE ENGINEER.

RESTORATION SUMMARY: RADIUM ST. STA. 7+50 TO END / 158TH AVE. STA. 3+00 TO END

SEEDING AREA	0.28 AC
HYDROMULCH (4000 LB/AC)	1040 LB
ERO. BLANKET CAT. 20	102 SY
SEED MIX 25-141 (59 LB/AC)	0 LB
SEED MIX 25-151 (200 LB/AC)	56 LB
FERTILIZER TYPE 3 (200 LB/AC)	56 LB
TOPSOIL	199 CY
DRIVE - BITUMINOUS	5 TON
DRIVE - CONCRETE	75 SY
DRIVE - GRAVEL SURFACE	0 SY

PROJECT TOTAL

SEEDING AREA	2.99 AC
HYDROMULCH	6100 LB
ERO. BLANKET CAT. 20	2234 SY
SEED MIX 25-141	24 LB
SEED MIX 25-151	322 LB
FERTILIZER TYPE 3	398 LB
TOPSOIL	1394 CY
DRIVE - BITUMINOUS	41 TON
DRIVE - CONCRETE	225 SY
DRIVE - GRAVEL SURFACE	97 SY

DATE	REVISION

I hereby certify that this plan, specification, or report was prepared by me or under my direct supervision and that I am a duly Licensed Professional Engineer Under the laws of the State of Minnesota.

Joe Feriancek
JOE FERIANCEK
 Date: 1/23/24 Lic. No. 57095

DESIGNED BY:	JJF
DRAWN BY:	JJF
CHECKED BY:	BRW
DATE:	12/15/23
FILE:	24-02

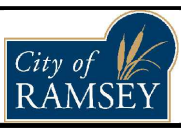

CITY OF RAMSEY
 7550 SUNWOOD DRIVE
 RAMSEY, MN 55303
 (763) 427-1410 FAX (763) 433-9898

RESTORATION

HALLS DOVER ACRES STREET RECONSTRUCTIONS
CITY PROJECT NO. 24-02
 CITY OF RAMSEY, MINNESOTA

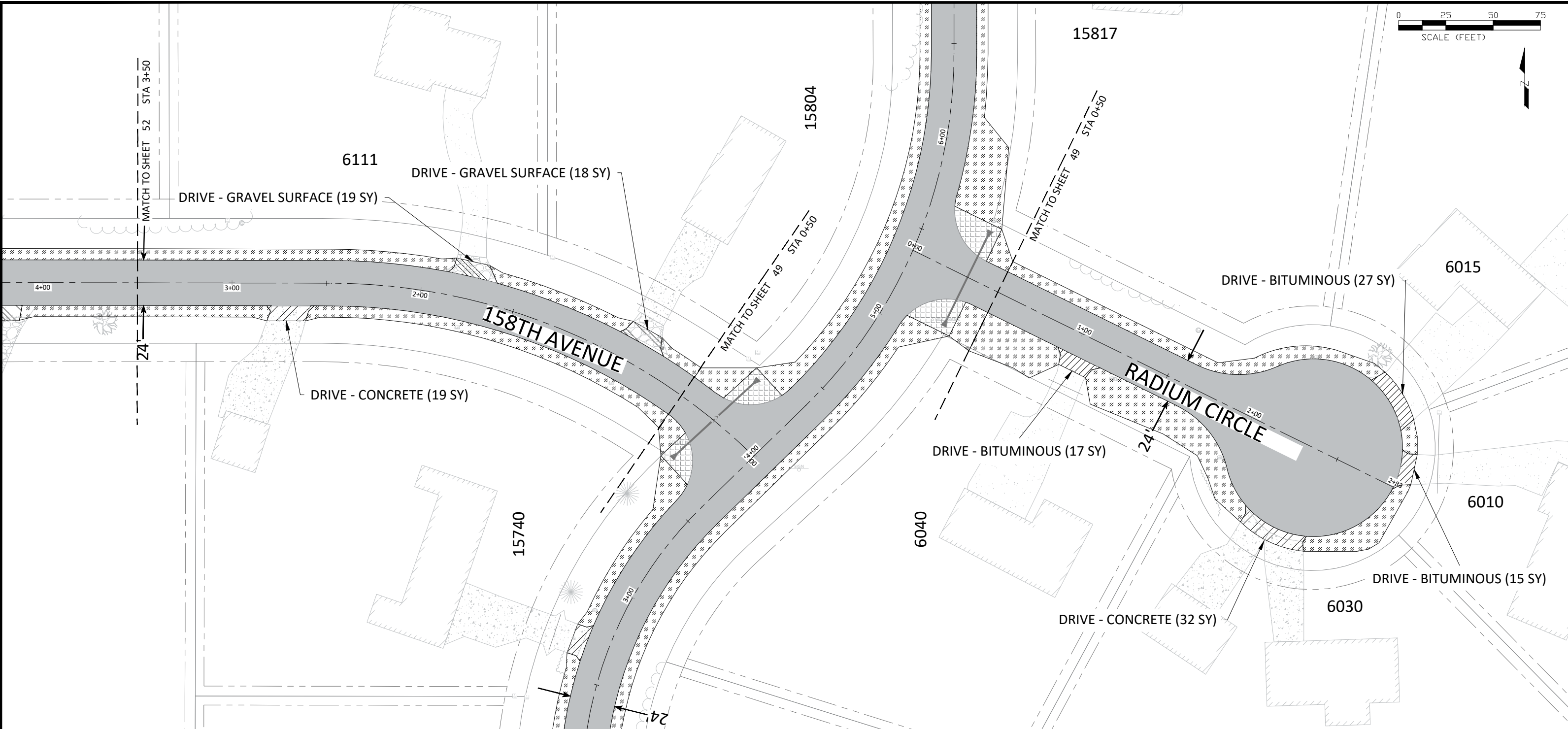

LEGEND

	SEED & MULCH AREA		PR. BITUMINOUS PAVEMENT - ROADWAY
	EROSION CONTROL BLANKET		PR. BITUMINOUS PAVEMENT - COUNTY
	WATERMAIN		PR. BITUMINOUS PAVEMENT - TRAIL
	SANITARY SEWER		PR. DRIVE - BITUMINOUS
	STORM SEWER		PR. DRIVE - CONCRETE
	DRAINAGE & UTILITY EASEMENT		PR. DRIVE - GRAVEL SURFACE
	RIGHT OF WAY LINE		PR. 6" CONCRETE WALK
	SECTION LINE		

NOTE:

- RESTORATION AREAS ARE SHOWN IN A GENERAL MANNER ONLY.
- RESTORE ALL DISTURBED AREAS WITH 4" TOPSOIL, HYDROSEED, MNDOT SEED MIX 25-151, AND HYDRAULIC MATRIX TYPE MULCH UNLESS MARKED FOR EROSION CONTROL BLANKET.
- RESTORE ALL AREAS MARKED FOR EROSION CONTROL BLANKET WITH 4" TOPSOIL, MNDOT SEED MIX 25-141 UNLESS NOTED OTHERWISE, AND ROLLED EROSION PREVENTION CATEGORY 20.
- STOCKPILING OF ANY SALVAGED TOPSOIL USED IS INCIDENTAL TO THE TOPSOIL PAY ITEM.
- CONTRACTOR IS RESPONSIBLE FOR RESTORING ALL LANDSCAPING TO AS GOOD OR BETTER CONDITION. PAYMENT MADE UNDER LANDSCAPE RESTORATION.
- SALVAGED ITEMS ARE TO BE RE-INSTALLED TO ORIGINAL LOCATION(S) OR AS DIRECTED BY THE ENGINEER.

RESTORATION SUMMARY: 158TH AVE. STA. 0+00 TO 3+50 / RADIUM CIRCLE

SEEDING AREA	0.18 AC
HYDROMULCH (4000 LB/AC)	720 LB
ERO. BLANKET CAT. 20	0 SY
SEED MIX 25-141 (59 LB/AC)	0 LB
SEED MIX 25-151 (200 LB/AC)	36 LB
FERTILIZER TYPE 3 (200 LB/AC)	36 LB
TOPSOIL	128 CY
DRIVE - BITUMINOUS	7 TON
DRIVE - CONCRETE	51 SY
DRIVE - GRAVEL SURFACE	37 SY

PROJECT TOTAL

SEEDING AREA	2.99 AC
HYDROMULCH	6100 LB
ERO. BLANKET CAT. 20	2234 SY
SEED MIX 25-141	24 LB
SEED MIX 25-151	322 LB
FERTILIZER TYPE 3	398 LB
TOPSOIL	1394 CY
DRIVE - BITUMINOUS	41 TON
DRIVE - CONCRETE	225 SY
DRIVE - GRAVEL SURFACE	97 SY

DATE	REVISION

I hereby certify that this plan, specification, or report was prepared by me or under my direct supervision and that I am a duly Licensed Professional Engineer under the laws of the State of Minnesota.

Joe Feriancek
JOE FERIANCEK
Date: 1/23/24 Lic. No. 57095

DESIGNED BY:	JJF
DRAWN BY:	JJF
CHECKED BY:	BRW
DATE:	12/15/23
FILE:	24-02

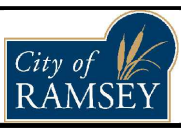

CITY OF RAMSEY
7550 SUNWOOD DRIVE
RAMSEY, MN 55303
(763) 427-1410 FAX (763) 433-9898

RESTORATION

HALLS DOVER ACRES STREET RECONSTRUCTIONS
CITY PROJECT NO. 24-02
CITY OF RAMSEY, MINNESOTA

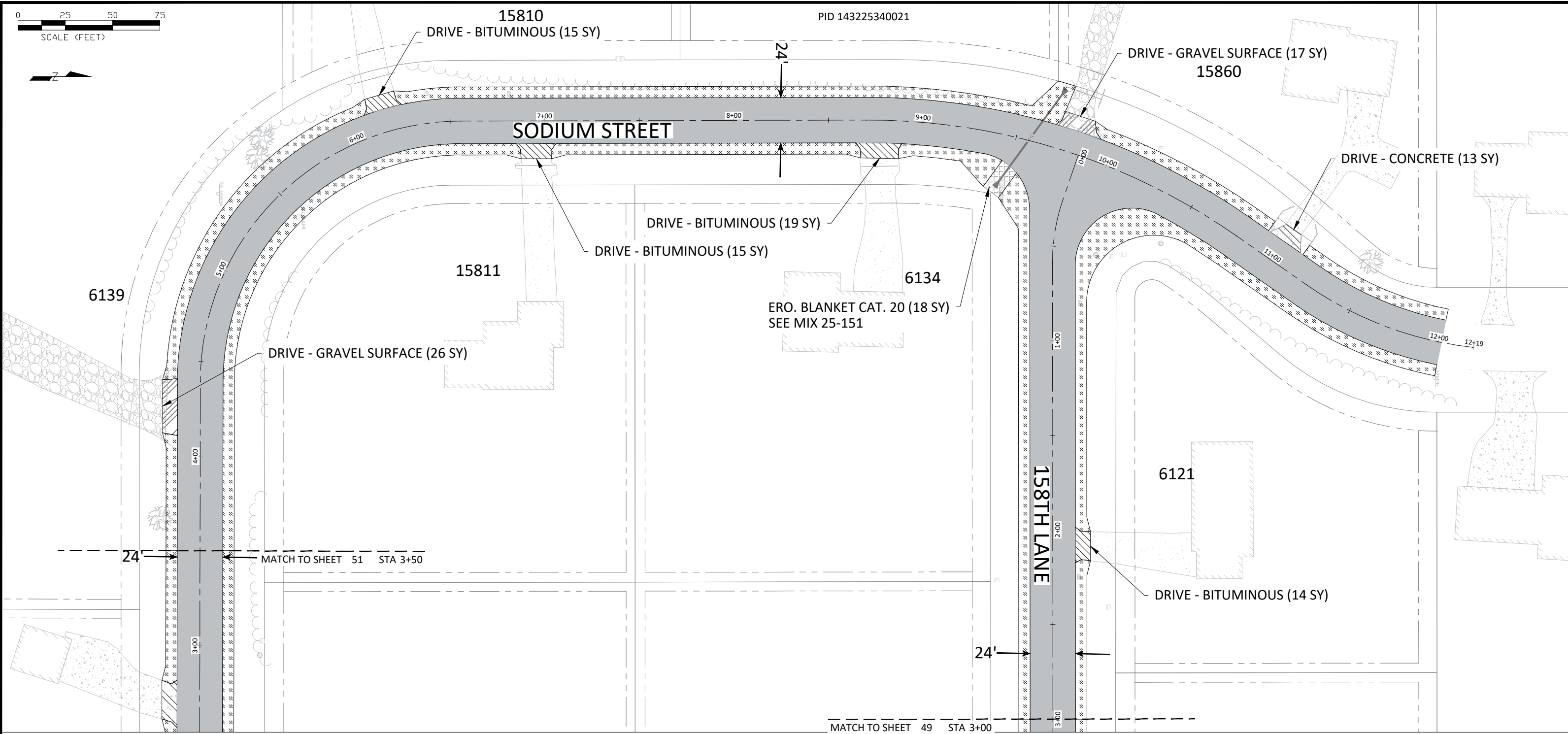
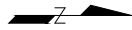

LEGEND

	SEED & MULCH AREA		PR. BITUMINOUS PAVEMENT - ROADWAY
	EROSION CONTROL BLANKET		PR. BITUMINOUS PAVEMENT - COUNTY
	WATERMAIN		PR. BITUMINOUS PAVEMENT - TRAIL
	SANITARY SEWER		PR. DRIVE - BITUMINOUS
	STORM SEWER		PR. DRIVE - CONCRETE
	DRAINAGE & UTILITY EASEMENT		PR. DRIVE - GRAVEL SURFACE
	RIGHT OF WAY LINE		PR. 6" CONCRETE WALK
	SECTION LINE		

NOTE:

- RESTORATION AREAS ARE SHOWN IN A GENERAL MANNER ONLY.
- RESTORE ALL DISTURBED AREAS WITH 4" TOPSOIL, HYDROSEED, MNDOT SEED MIX 25-151, AND HYDRAULIC MATRIX TYPE MULCH UNLESS MARKED FOR EROSION CONTROL BLANKET.
- RESTORE ALL AREAS MARKED FOR EROSION CONTROL BLANKET WITH 4" TOPSOIL, MNDOT SEED MIX 25-141 UNLESS NOTED OTHERWISE, AND ROLLED EROSION PREVENTION CATEGORY 20.
- STOCKPILING OF ANY SALVAGED TOPSOIL USED IS INCIDENTAL TO THE TOPSOIL PAY ITEM.
- CONTRACTOR IS RESPONSIBLE FOR RESTORING ALL LANDSCAPING TO AS GOOD OR BETTER CONDITION. PAYMENT MADE UNDER LANDSCAPE RESTORATION.
- SALVAGED ITEMS ARE TO BE RE-INSTALLED TO ORIGINAL LOCATION(S) OR AS DIRECTED BY THE ENGINEER.

RESTORATION SUMMARY: SODIUM ST. STA. 3+50 TO END / 158TH AVE. STA. 0+00 TO 3+00

SEEDING AREA	0.32 AC
HYDROMULCH (4000 LB/AC)	1240 LB
ERO. BLANKET CAT. 20	18 SY
SEED MIX 25-141 (59 LB/AC)	0 LB
SEED MIX 25-151 (200 LB/AC)	64 LB
FERTILIZER TYPE 3 (200 LB/AC)	64 LB
TOPSOIL	217 CY
DRIVE - BITUMINOUS	8 TON
DRIVE - CONCRETE	13 SY
DRIVE - GRAVEL SURFACE	43 SY

PROJECT TOTAL

SEEDING AREA	2.99 AC
HYDROMULCH	6100 LB
ERO. BLANKET CAT. 20	2234 SY
SEED MIX 25-141	24 LB
SEED MIX 25-151	322 LB
FERTILIZER TYPE 3	398 LB
TOPSOIL	1394 CY
DRIVE - BITUMINOUS	41 TON
DRIVE - CONCRETE	225 SY
DRIVE - GRAVEL SURFACE	97 SY

DATE	REVISION

I hereby certify that this plan, specification, or report was prepared by me or under my direct supervision and that I am a duly Licensed Professional Engineer Under the laws of the State of Minnesota

Joe Feriancek
 JOE FERIANCEK
 Date 1/23/24 Lic. No. 57095

DESIGNED BY:	JJF
DRAWN BY:	JJF
CHECKED BY:	BRW
DATE:	12/15/23
FILE:	24-02

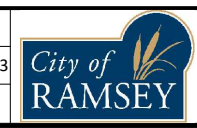

CITY OF RAMSEY
 7550 SUNWOOD DRIVE
 RAMSEY, MN 55303
 (763) 427-1410 FAX (763) 433-9898

RESTORATION

HALLS DOVER ACRES STREET RECONSTRUCTIONS
 CITY PROJECT NO. 24-02
 CITY OF RAMSEY, MINNESOTA

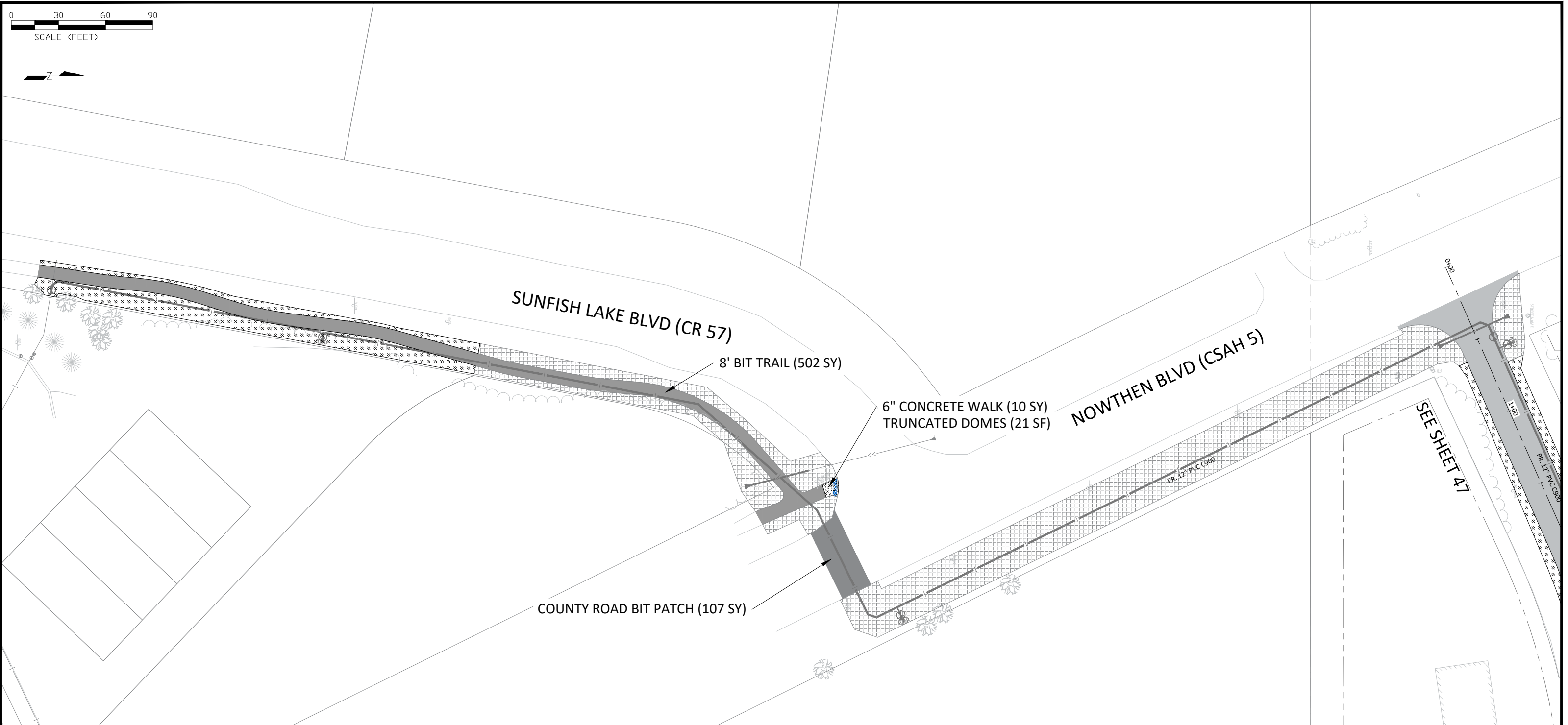

LEGEND

	SEED & MULCH AREA		PR. BITUMINOUS PAVEMENT - ROADWAY
	EROSION CONTROL BLANKET		PR. BITUMINOUS PAVEMENT - COUNTY
	WATERMAIN		PR. BITUMINOUS PAVEMENT - TRAIL
	SANITARY SEWER		PR. DRIVE - BITUMINOUS
	STORM SEWER		PR. DRIVE - CONCRETE
	DRAINAGE & UTILITY EASEMENT		PR. DRIVE - GRAVEL SURFACE
	RIGHT OF WAY LINE		PR. 6" CONCRETE WALK
	SECTION LINE		

NOTE:

- RESTORATION AREAS ARE SHOWN IN A GENERAL MANNER ONLY.
- RESTORE ALL DISTURBED AREAS WITH 4" TOPSOIL, HYDROSEED, MNDOT SEED MIX 25-151, AND HYDRAULIC MATRIX TYPE MULCH UNLESS MARKED FOR EROSION CONTROL BLANKET.
- RESTORE ALL AREAS MARKED FOR EROSION CONTROL BLANKET WITH 4" TOPSOIL, MNDOT SEED MIX 25-141 UNLESS NOTED OTHERWISE, AND ROLLED EROSION PREVENTION CATEGORY 20.
- STOCKPILING OF ANY SALVAGED TOPSOIL USED IS INCIDENTAL TO THE TOPSOIL PAY ITEM.
- CONTRACTOR IS RESPONSIBLE FOR RESTORING ALL LANDSCAPING TO AS GOOD OR BETTER CONDITION. PAYMENT MADE UNDER LANDSCAPE RESTORATION.
- SALVAGED ITEMS ARE TO BE RE-INSTALLED TO ORIGINAL LOCATION(S) OR AS DIRECTED BY THE ENGINEER.

RESTORATION SUMMARY: WATERMAIN ROUTE

SEEDING AREA	0.44 AC
HYDROMULCH (4000 LB/AC)	320 LB
ERO. BLANKET CAT. 20	1737 SY
SEED MIX 25-141 (59 LB/AC)	22 LB
SEED MIX 25-151 (200 LB/AC)	16 LB
FERTILIZER TYPE 3 (200 LB/AC)	88 LB
TOPSOIL	309 CY
DRIVE - BITUMINOUS	0 TON
DRIVE - CONCRETE	0 SY
DRIVE - GRAVEL SURFACE	0 SY

PROJECT TOTAL

SEEDING AREA	2.99 AC
HYDROMULCH	6100 LB
ERO. BLANKET CAT. 20	2234 SY
SEED MIX 25-141	24 LB
SEED MIX 25-151	322 LB
FERTILIZER TYPE 3	398 LB
TOPSOIL	1394 CY
DRIVE - BITUMINOUS	41 TON
DRIVE - CONCRETE	225 SY
DRIVE - GRAVEL SURFACE	97 SY

DATE	REVISION

I hereby certify that this plan, specification, or report was prepared by me or under my direct supervision and that I am a duly Licensed Professional Engineer under the laws of the State of Minnesota.

Joe Feriancek
 JOE FERIANCEK
 Date: 1/23/24 Lic. No. 57095

DESIGNED BY:	JJF
DRAWN BY:	JJF
CHECKED BY:	BRW
DATE:	12/15/23
FILE:	24-02

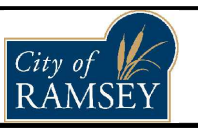

CITY OF RAMSEY
 7550 SUNWOOD DRIVE
 RAMSEY, MN 55303
 (763) 427-1410 FAX (763) 433-9898

RESTORATION

HALLS DOVER ACRES STREET RECONSTRUCTIONS
 CITY PROJECT NO. 24-02
 CITY OF RAMSEY, MINNESOTA

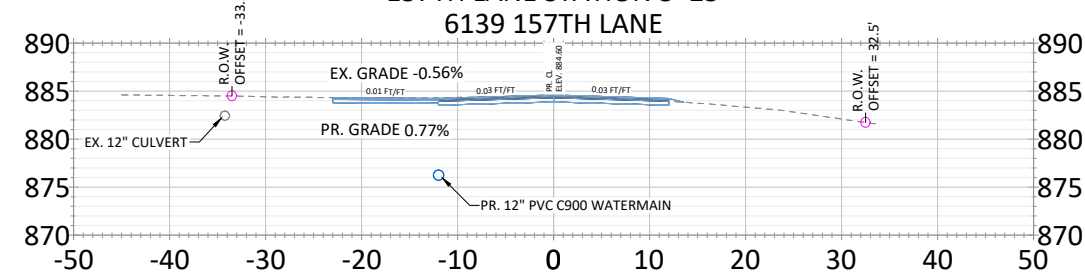
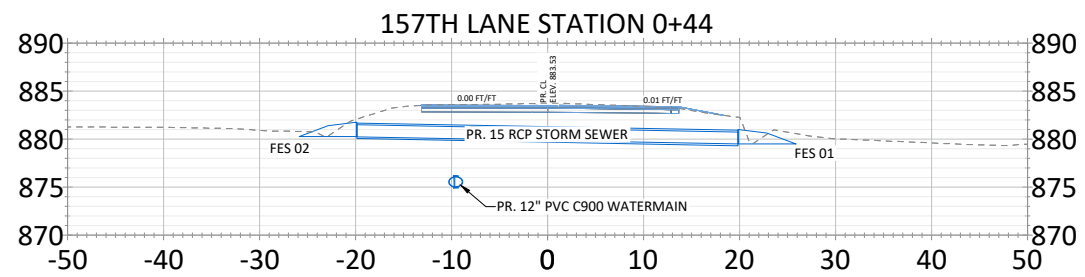
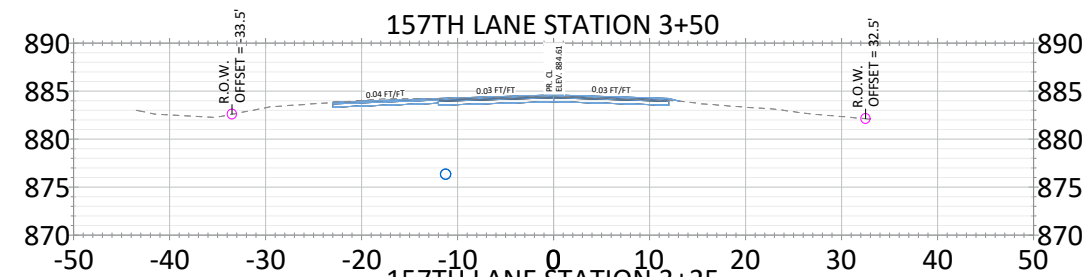
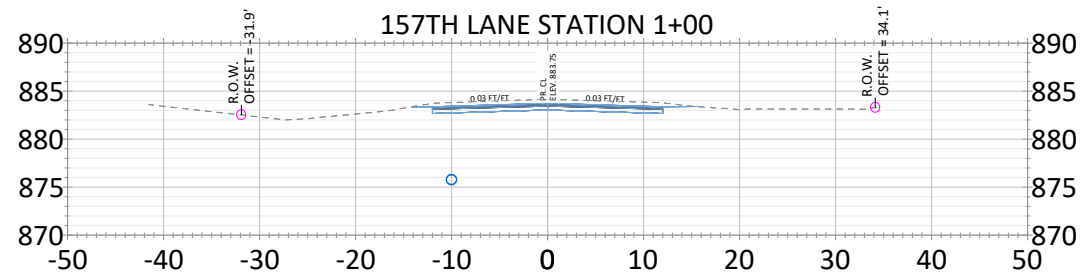
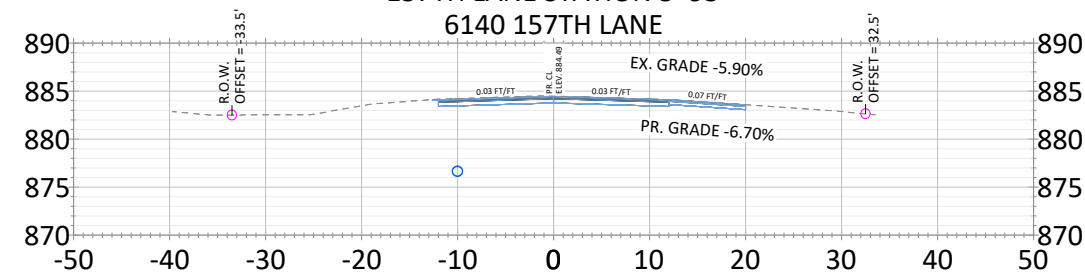
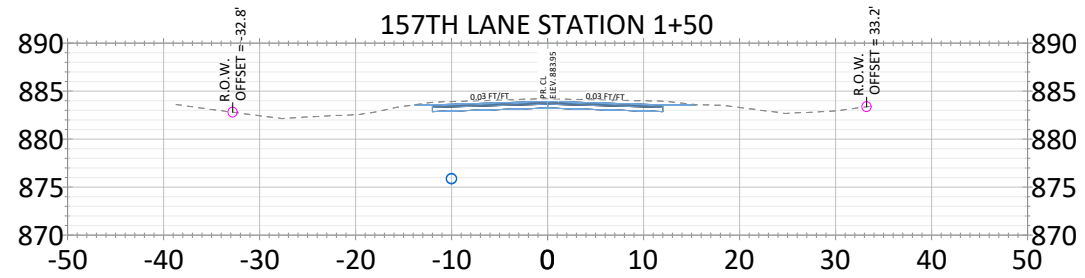
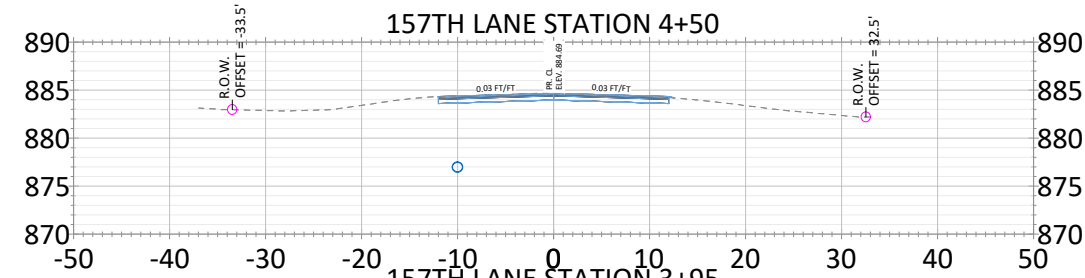
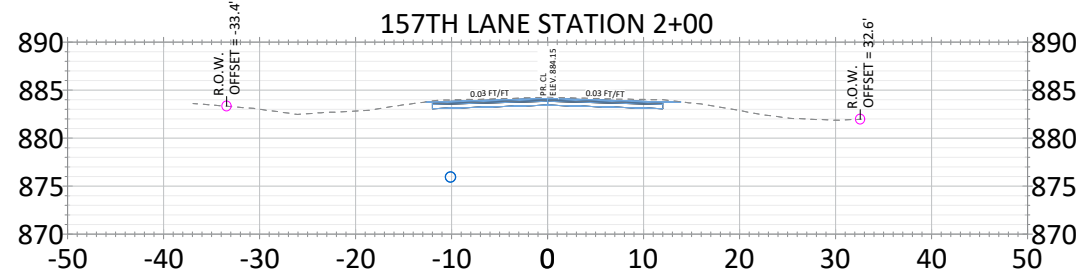
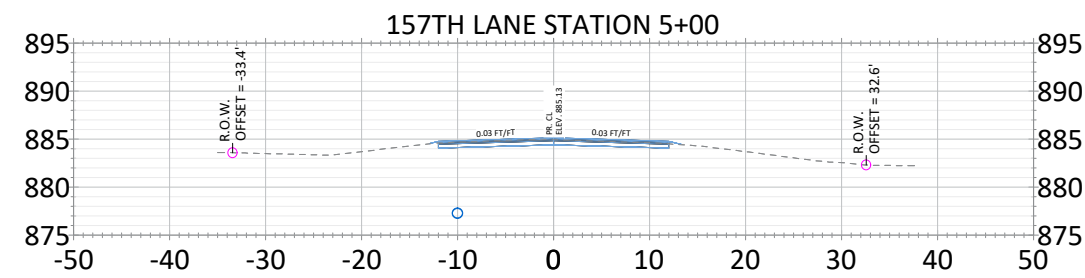
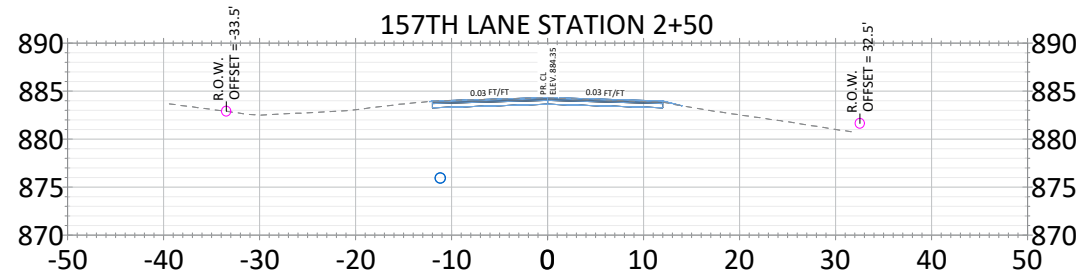
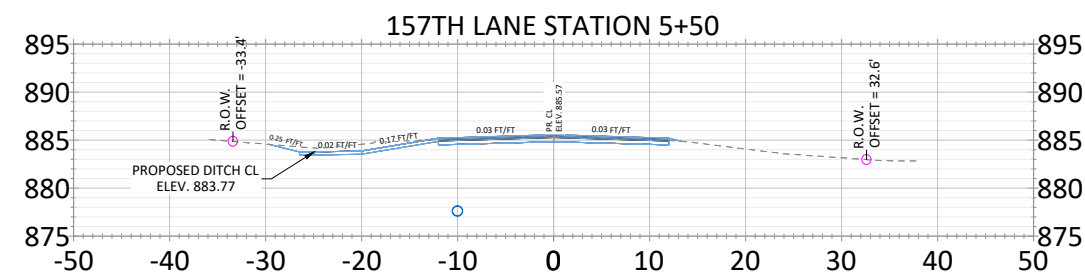
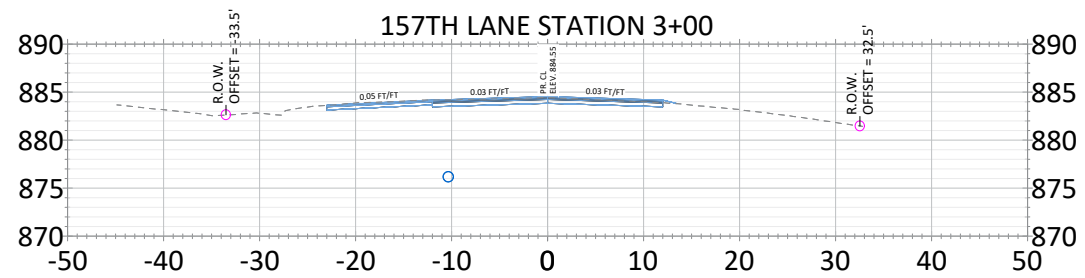

DATE	REVISION

I hereby certify that this plan, specification, or report was prepared by me or under my direct supervision and that I am a duly Licensed Professional Engineer under the laws of the State of Minnesota

JOE FERIANCEK
Date 1/23/24 Lic. No. 57095

DESIGNED BY: JJF
DRAWN BY: JJF DATE: 12/15/23
CHECKED BY: BRW FILE: 24-02

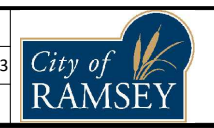

CITY OF RAMSEY
7550 SUNWOOD DRIVE
RAMSEY, MN 55303
(763) 427-1410 FAX (763) 433-9898

CROSS SECTIONS
157TH LANE

HALLS DOVER ACRES STREET RECONSTRUCTIONS
CITY PROJECT NO. 24-02
CITY OF RAMSEY, MINNESOTA

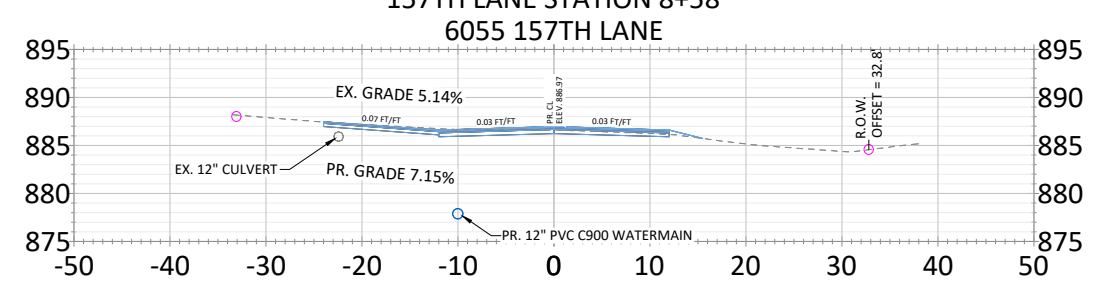
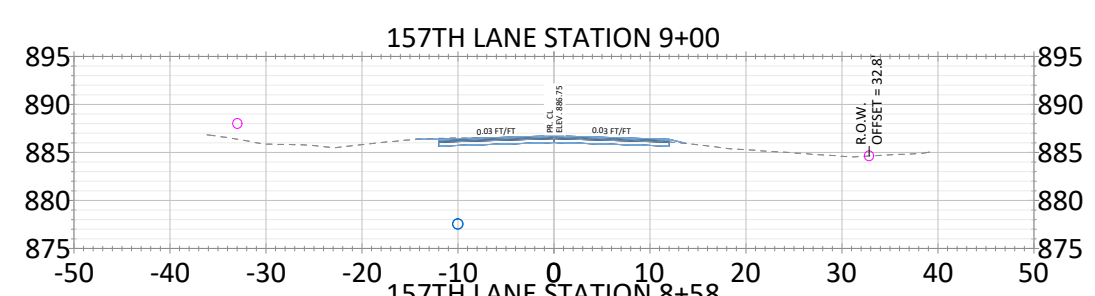
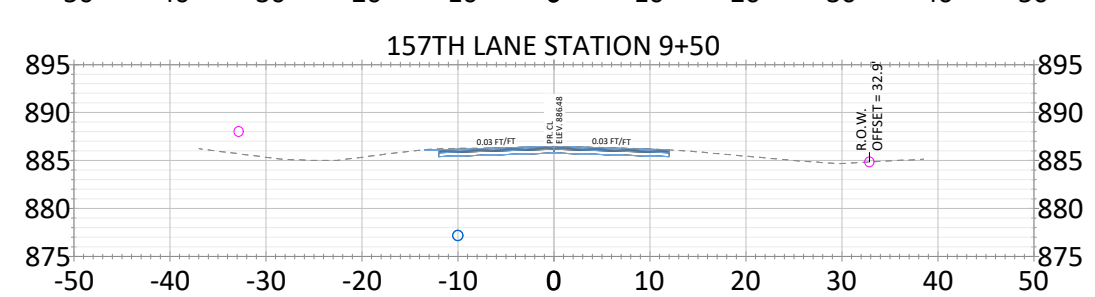
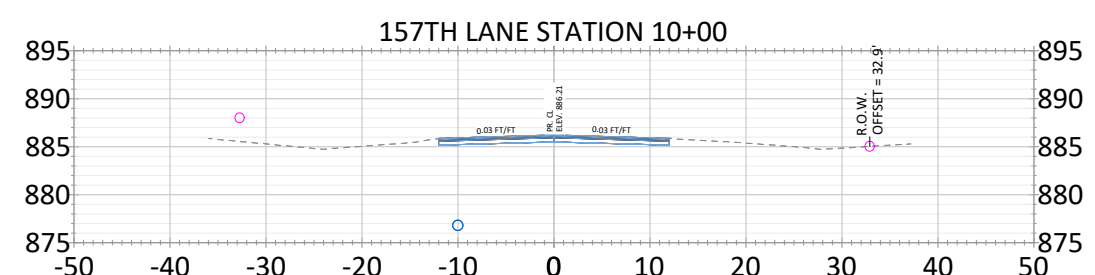
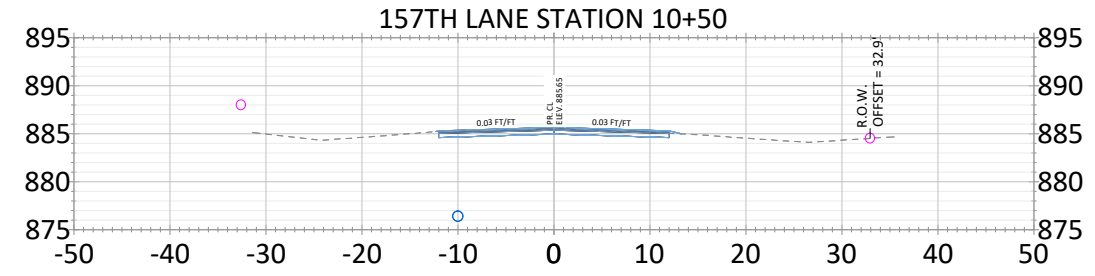
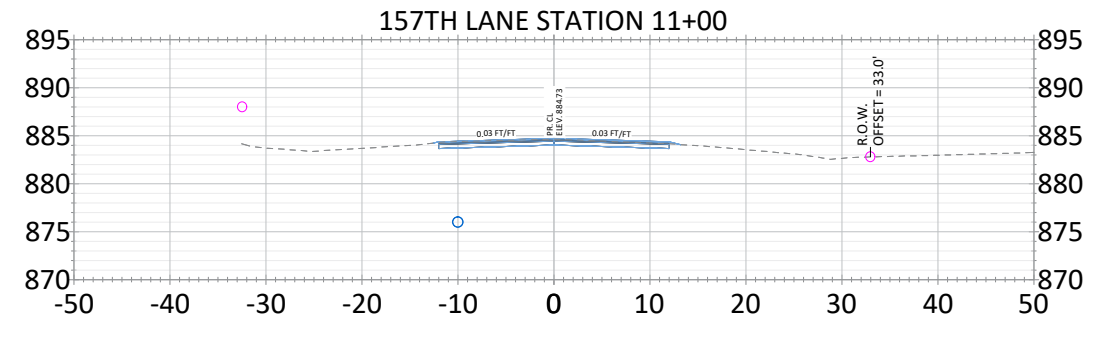
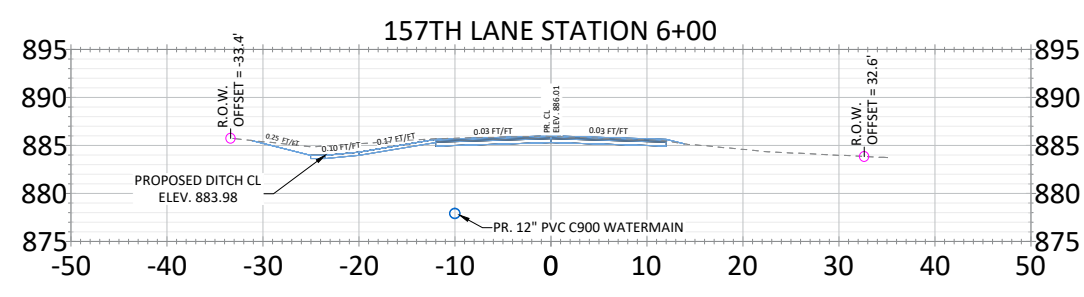
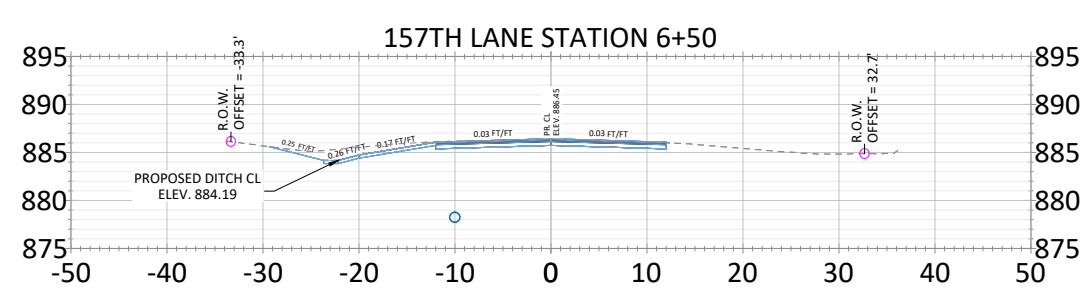
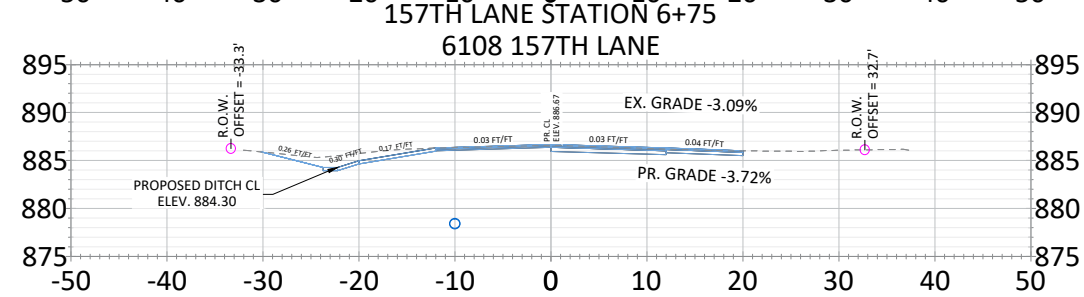
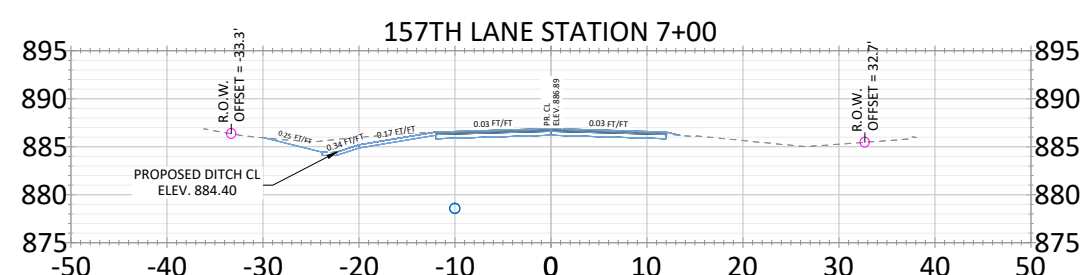
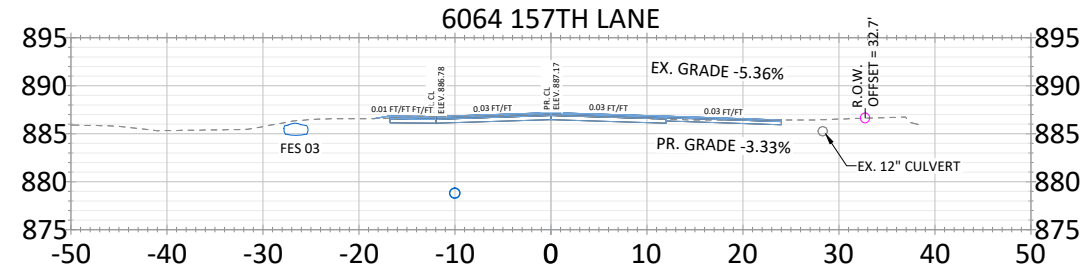
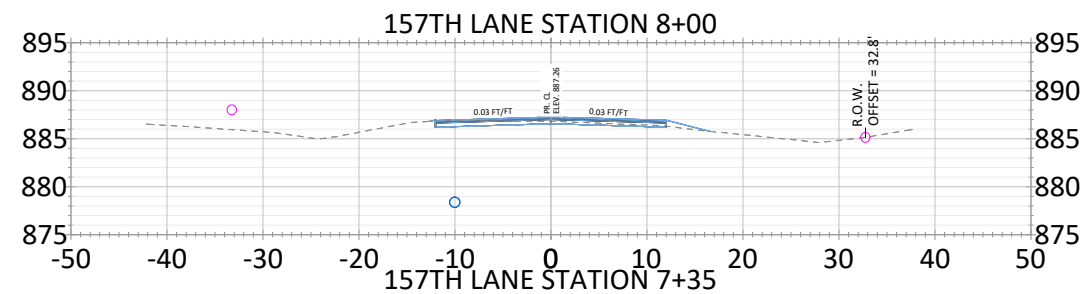

DATE	REVISION

I hereby certify that this plan, specification, or report was prepared by me or under my direct supervision and that I am a duly Licensed Professional Engineer under the laws of the State of Minnesota

JOE FERIANECK
Date 1/23/24 Lic. No. 57095

DESIGNED BY: JJF
DRAWN BY: JJF
CHECKED BY: BRW

DATE: 12/15/23
FILE: 24-02

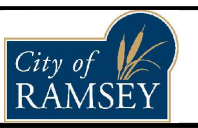

CITY OF RAMSEY
7550 SUNWOOD DRIVE
RAMSEY, MN 55303
(763) 427-1410 FAX (763) 433-9898

CROSS SECTIONS
157TH LANE

HALLS DOVER ACRES STREET RECONSTRUCTIONS
CITY PROJECT NO. 24-02
CITY OF RAMSEY, MINNESOTA

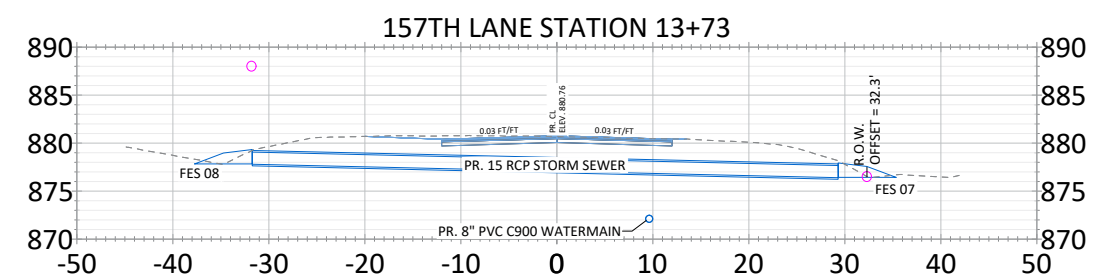
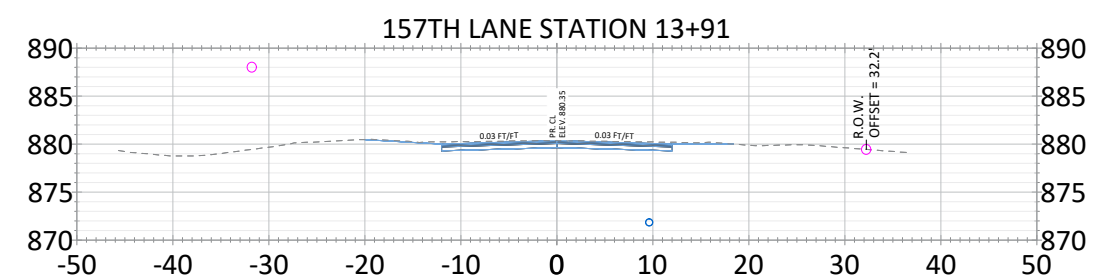
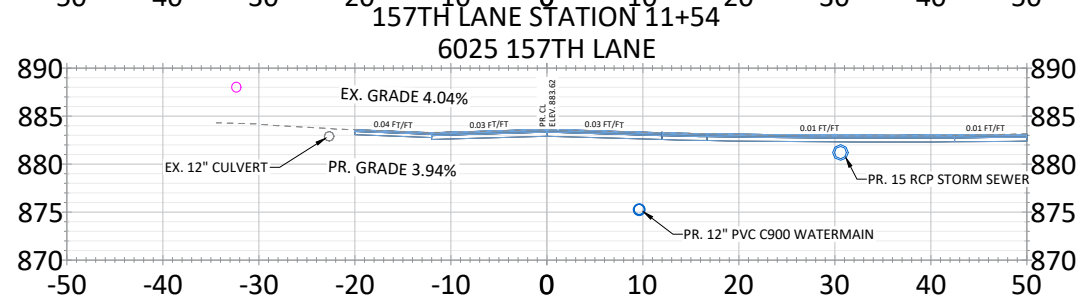
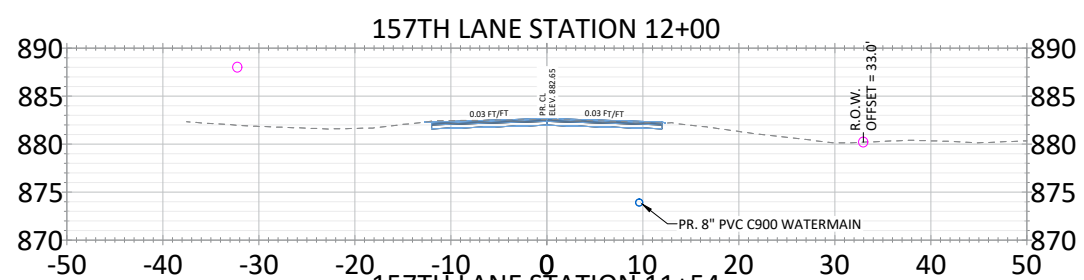
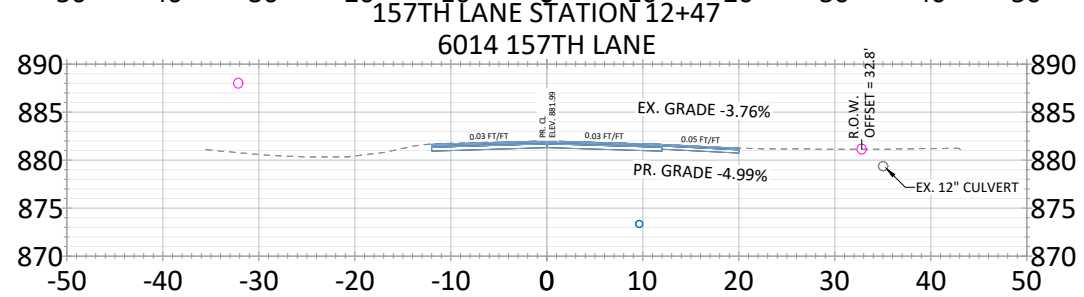
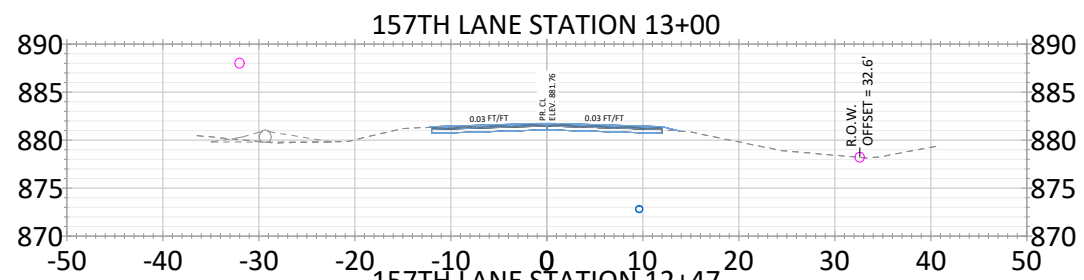
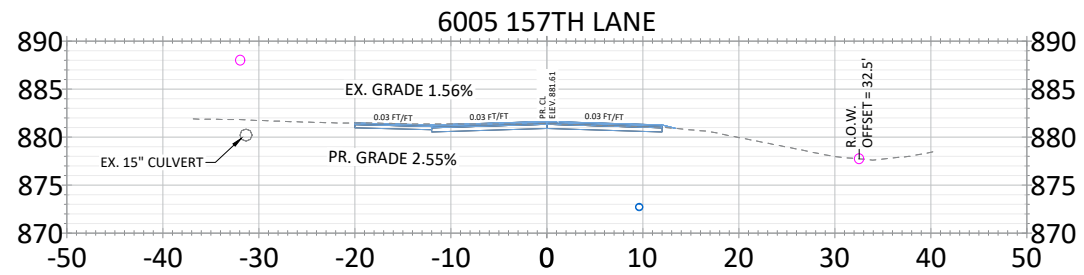
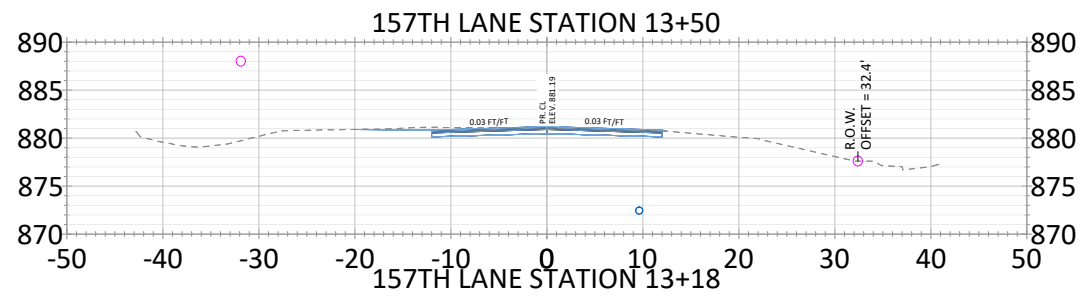

DATE	REVISION

I hereby certify that this plan, specification, or report was prepared by me or under my direct supervision and that I am a duly Licensed Professional Engineer under the laws of the State of Minnesota

JOE FERIANECK
Date 1/23/24 Lic. No. 57095

DESIGNED BY: JJF
DATE: 12/15/23
DRAWN BY: JJF
FILE: 24-02
CHECKED BY: BRW

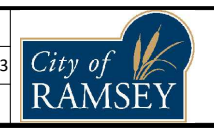

CITY OF RAMSEY
7550 SUNWOOD DRIVE
RAMSEY, MN 55303
(763) 427-1410 FAX (763) 433-9898

CROSS SECTIONS
157TH LANE

HALLS DOVER ACRES STREET RECONSTRUCTIONS
CITY PROJECT NO. 24-02
CITY OF RAMSEY, MINNESOTA

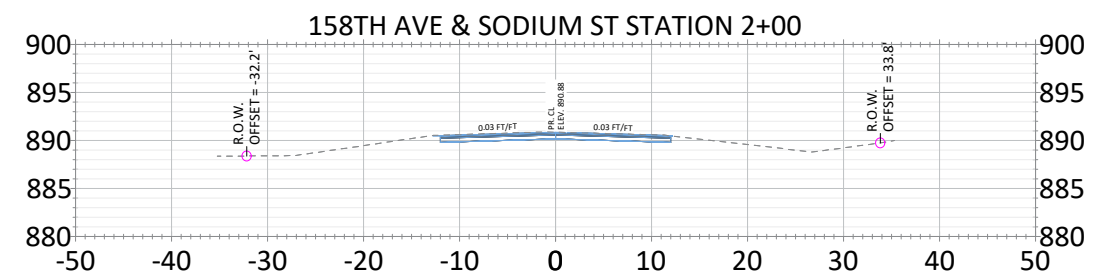
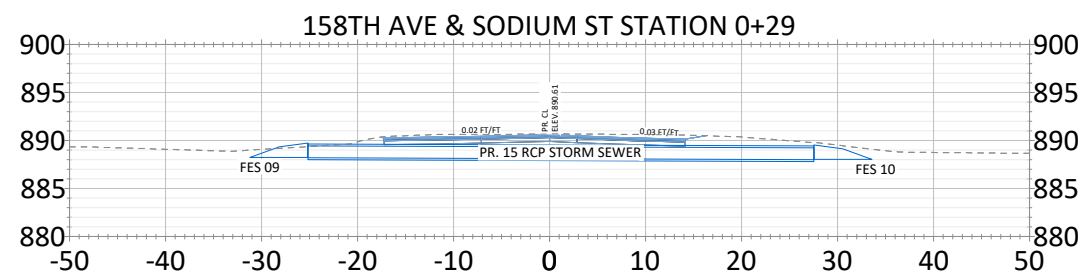
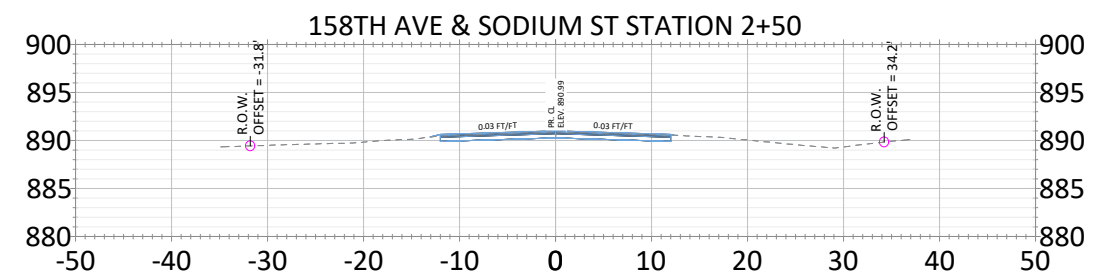
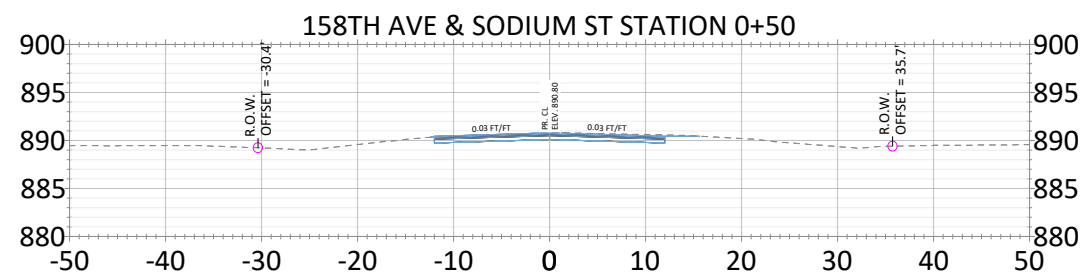
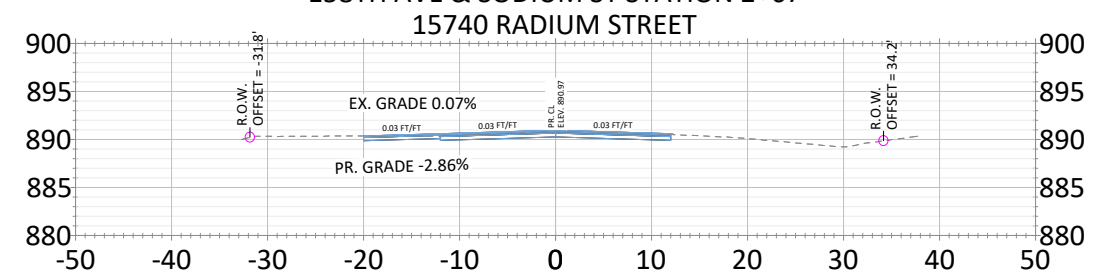
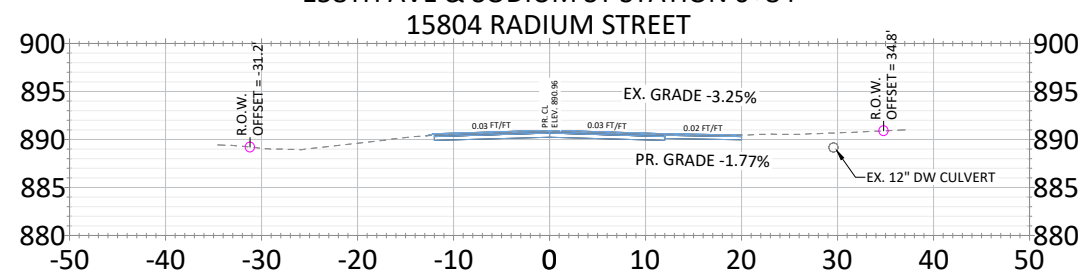
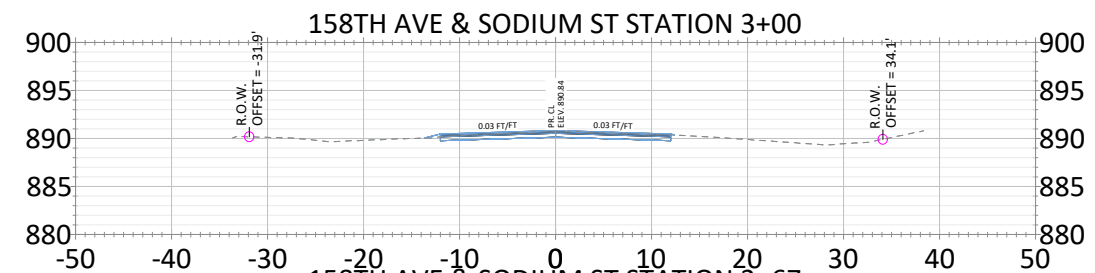
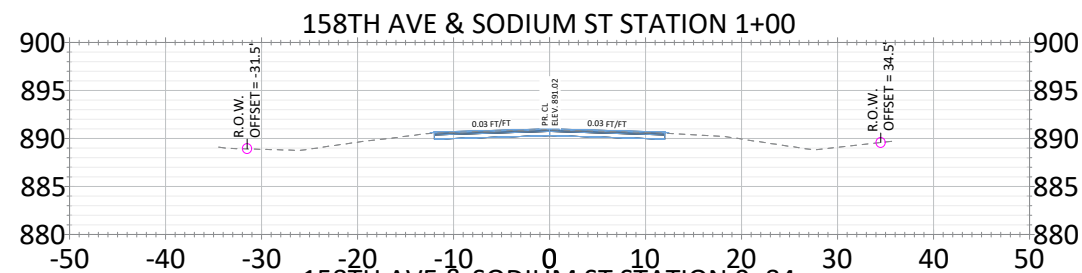
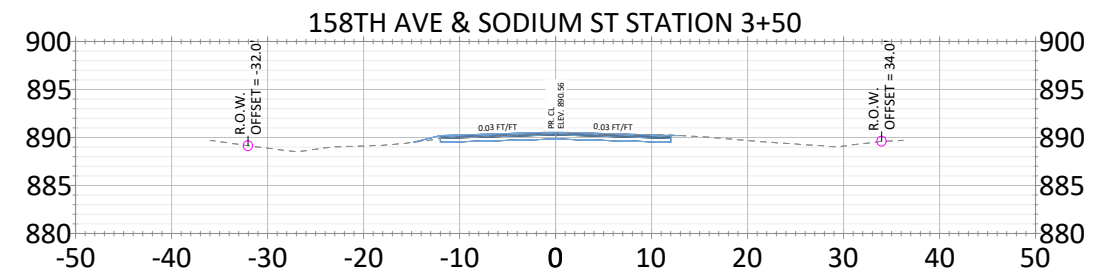
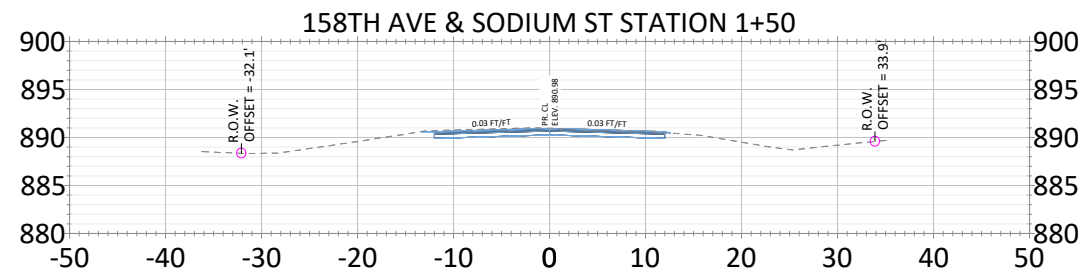
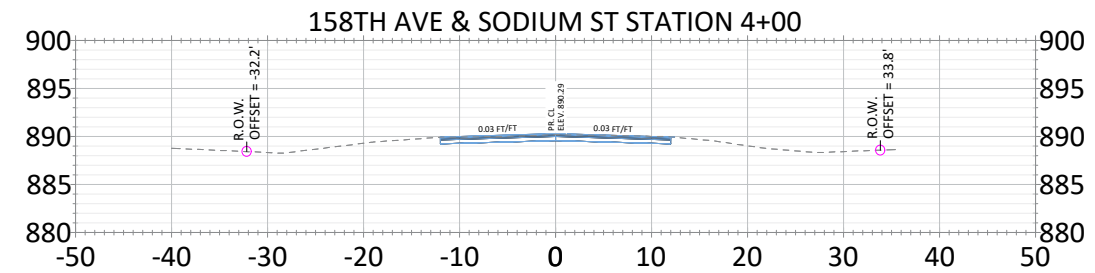
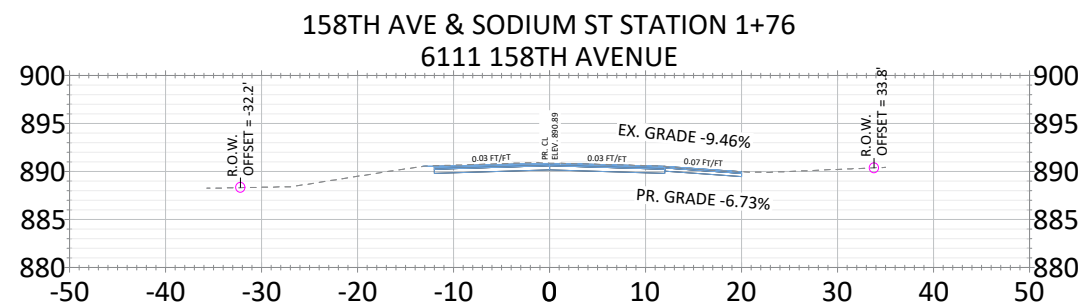

DATE	REVISION

I hereby certify that this plan, specification, or report was prepared by me or under my direct supervision and that I am a duly Licensed Professional Engineer under the laws of the State of Minnesota

JOE FERIANCEK
Date 1/23/24 Lic. No. 57095

DESIGNED BY: JJF
DRAWN BY: JJF
CHECKED BY: BRW

DATE: 12/15/23
FILE: 24-02

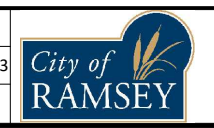

CITY OF RAMSEY
7550 SUNWOOD DRIVE
RAMSEY, MN 55303
(763) 427-1410 FAX (763) 433-9898

CROSS SECTIONS
158TH AVE & SODIUM ST

HALLS DOVER ACRES STREET RECONSTRUCTIONS
CITY PROJECT NO. 24-02
CITY OF RAMSEY, MINNESOTA

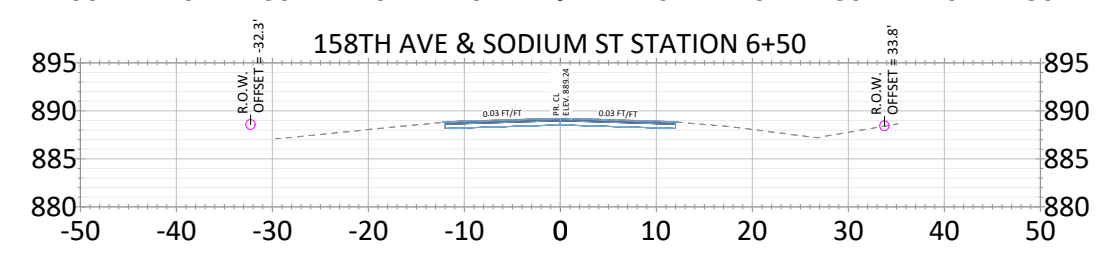
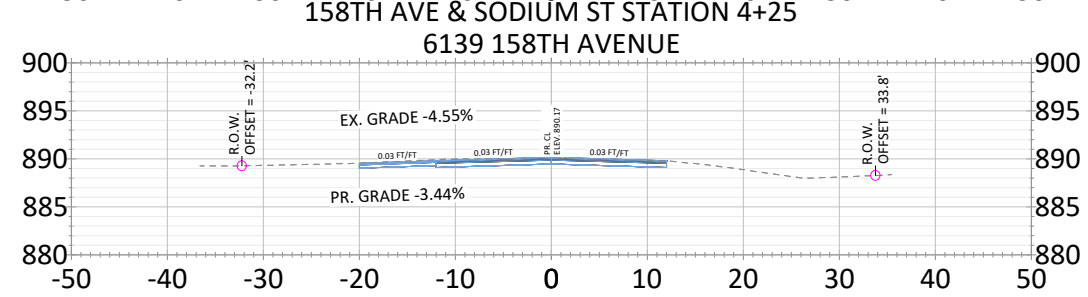
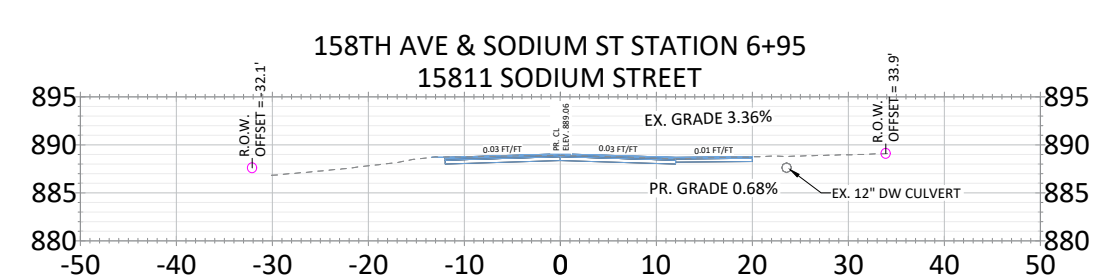
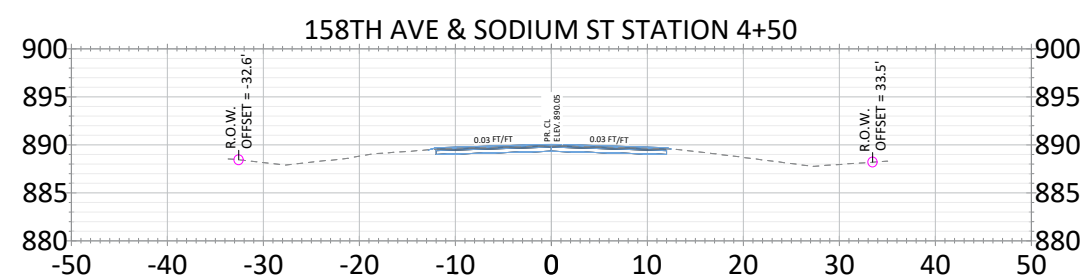
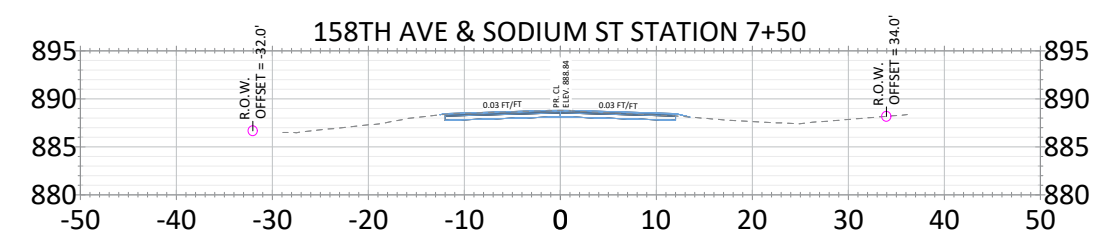
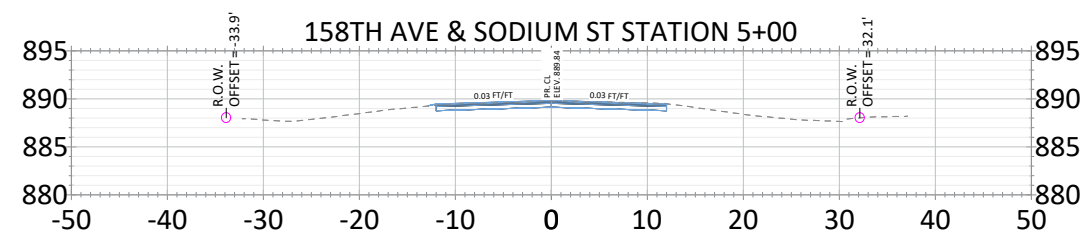
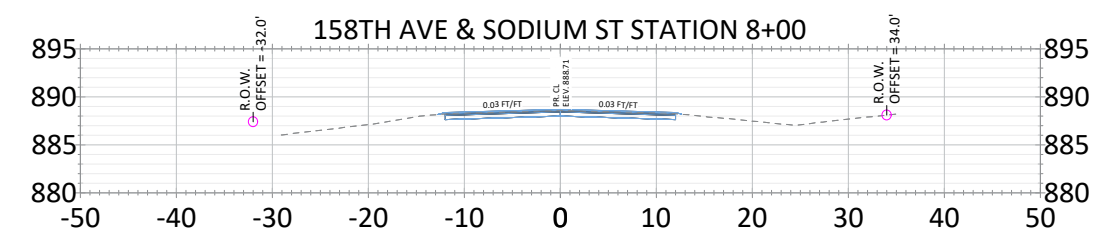
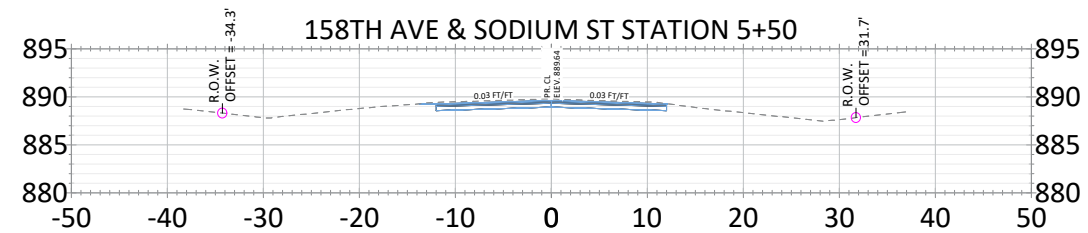
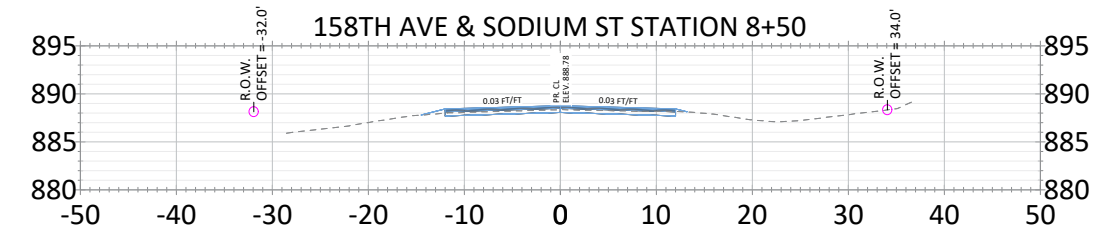
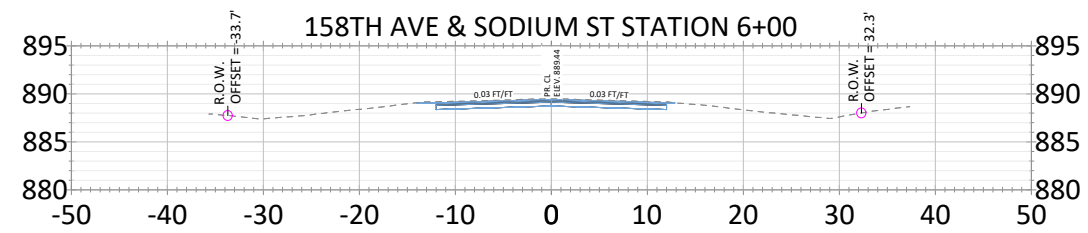
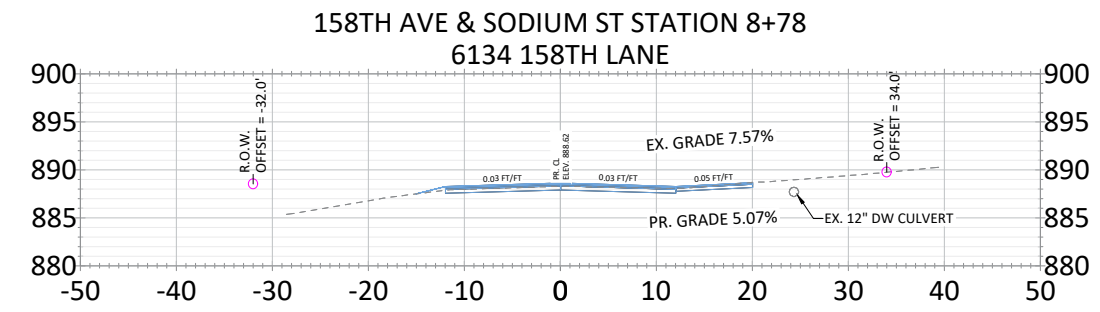
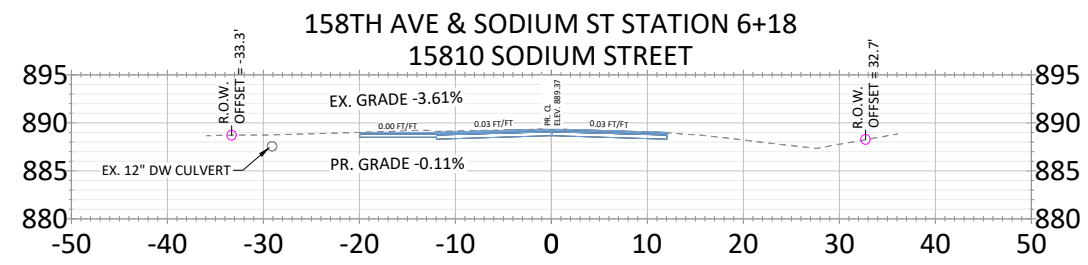

DATE	REVISION

I hereby certify that this plan, specification, or report was prepared by me or under my direct supervision and that I am a duly Licensed Professional Engineer under the laws of the State of Minnesota

JOE FERIANCEK
Date 1/23/24 Lic. No. 57095

DESIGNED BY: JJJ
DRAWN BY: JJJ
CHECKED BY: BRW

DATE: 12/15/23
FILE: 24-02

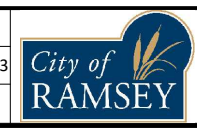

CITY OF RAMSEY
7550 SUNWOOD DRIVE
RAMSEY, MN 55303
(763) 427-1410 FAX (763) 433-9898

CROSS SECTIONS
158TH AVE & SODIUM ST

HALLS DOVER ACRES STREET RECONSTRUCTIONS
CITY PROJECT NO. 24-02
CITY OF RAMSEY, MINNESOTA

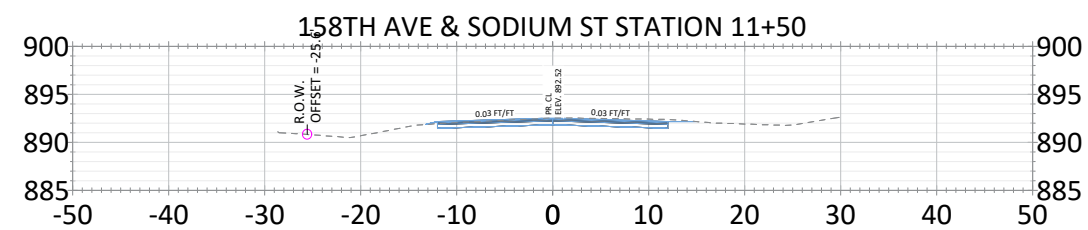
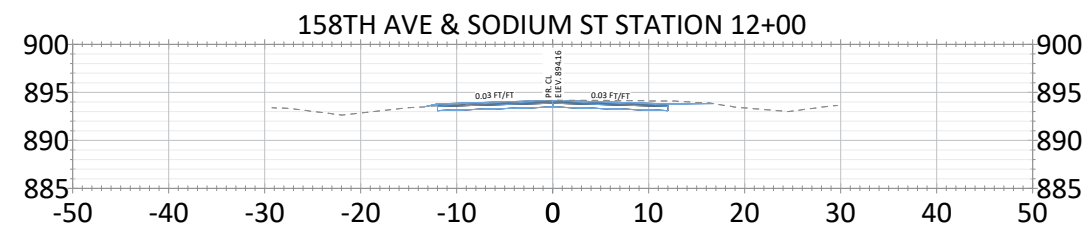
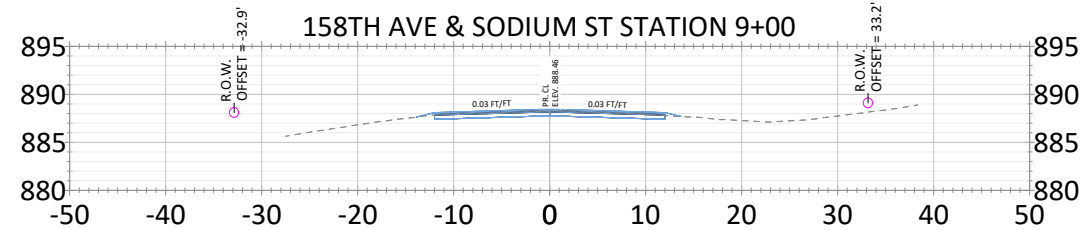
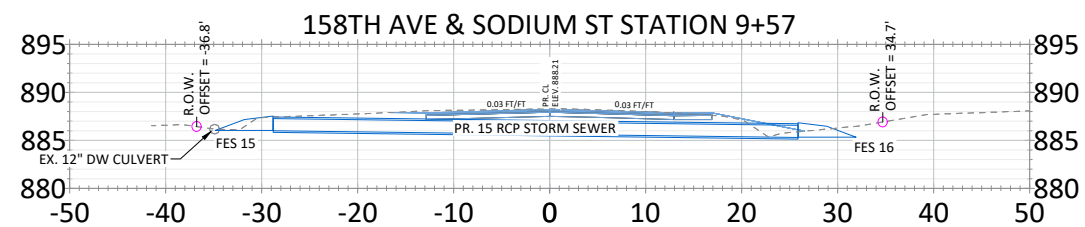
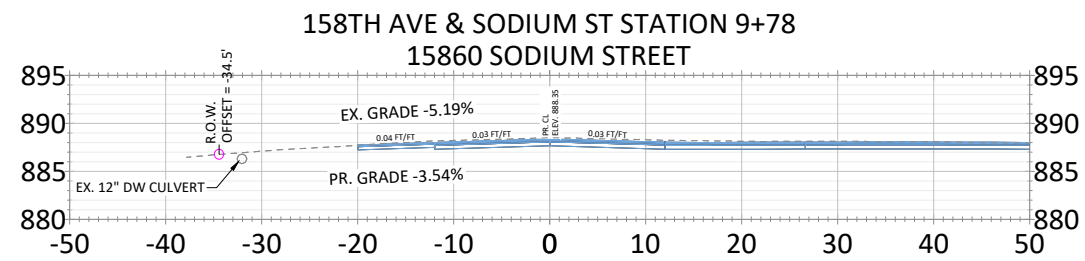
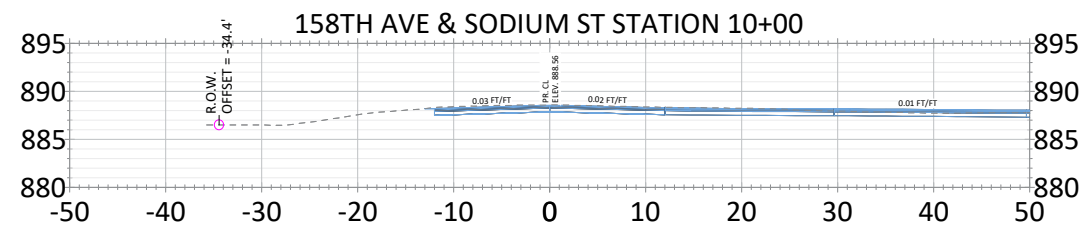
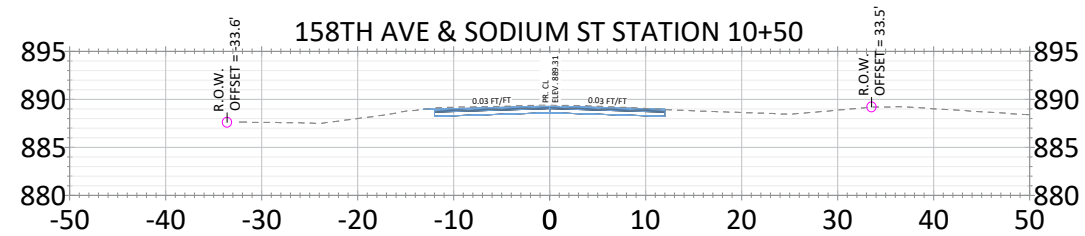
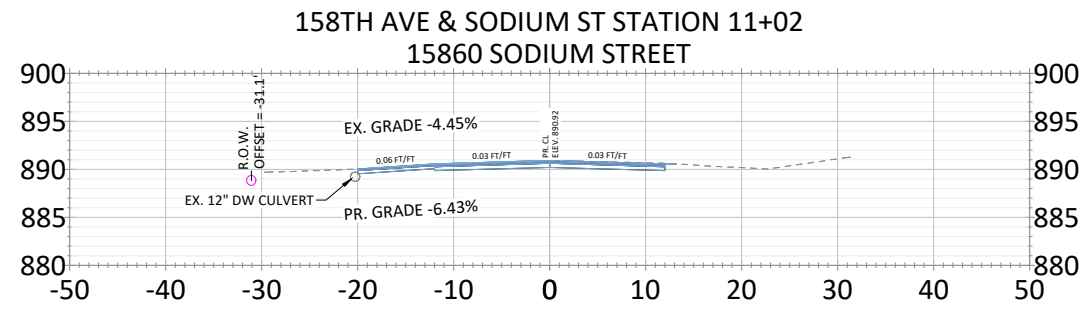

DATE	REVISION

I hereby certify that this plan, specification, or report was prepared by me or under my direct supervision and that I am a duly Licensed Professional Engineer under the laws of the State of Minnesota

JOE FERIANECK
Date 1/23/24 Lic. No. 57095

DESIGNED BY: J JF
DRAWN BY: J JF
CHECKED BY: BRW

DATE: 12/15/23
FILE: 24-02

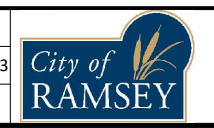

CITY OF RAMSEY
7550 SUNWOOD DRIVE
RAMSEY, MN 55303
(763) 427-1410 FAX (763) 433-9898

CROSS SECTIONS
158TH AVE & SODIUM ST

HALLS DOVER ACRES STREET RECONSTRUCTIONS
CITY PROJECT NO. 24-02
CITY OF RAMSEY, MINNESOTA

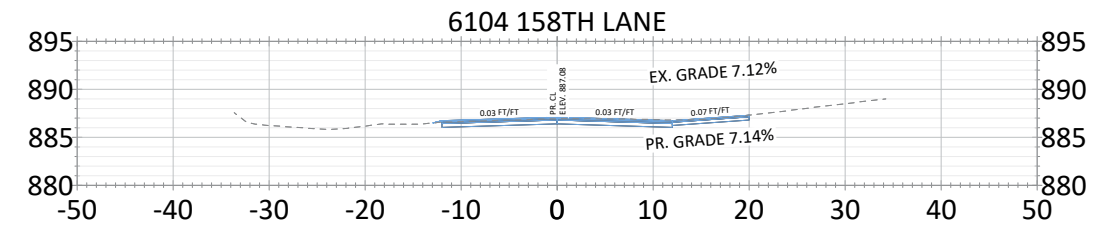
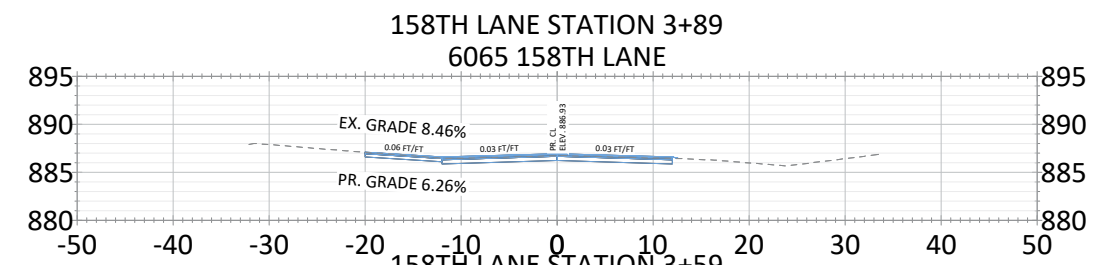
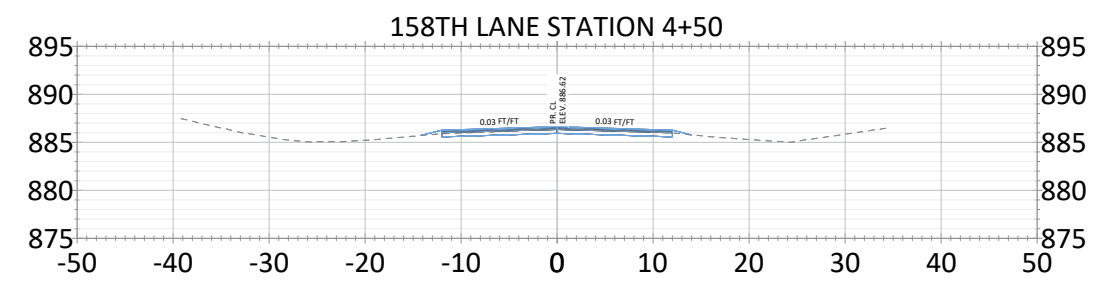
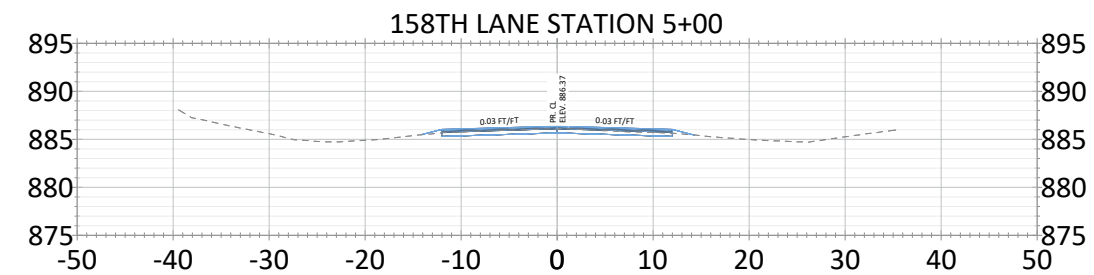
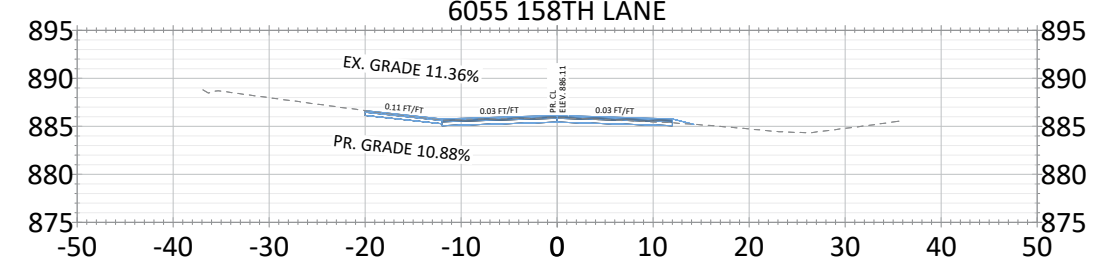
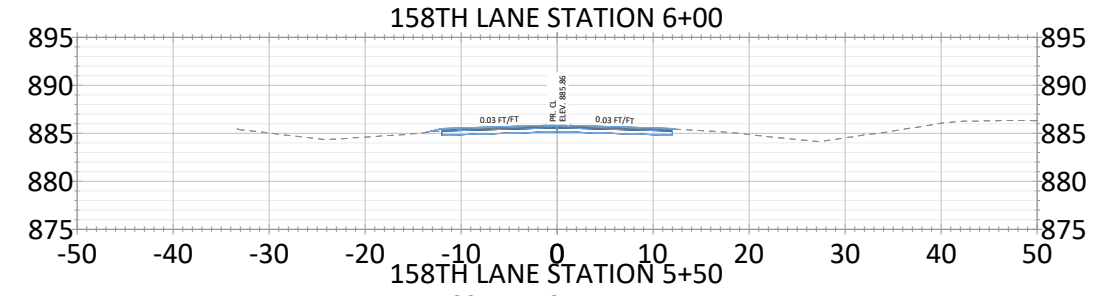
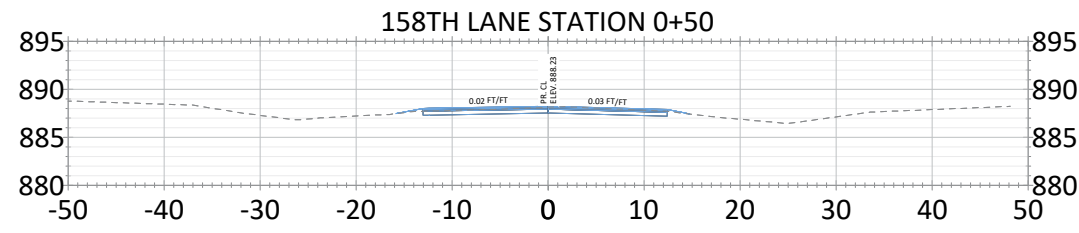
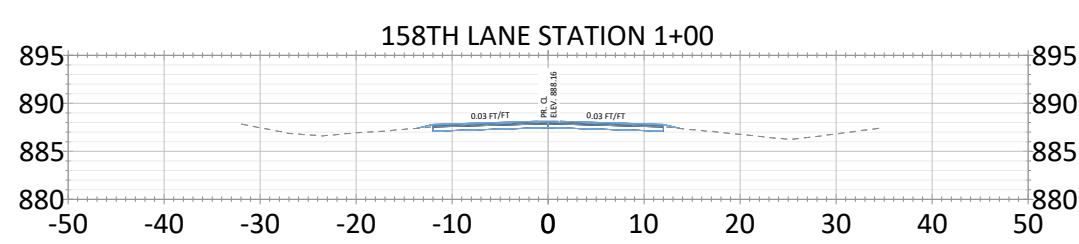
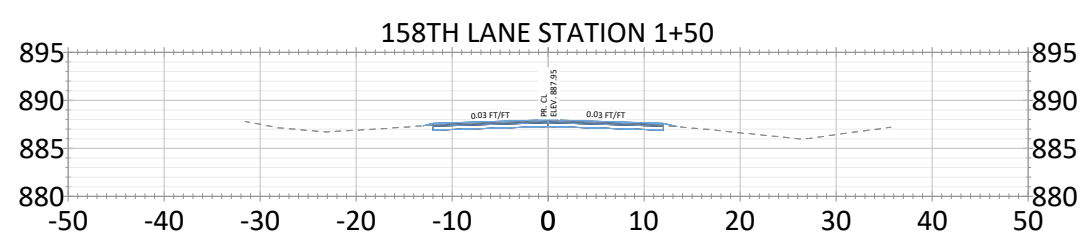
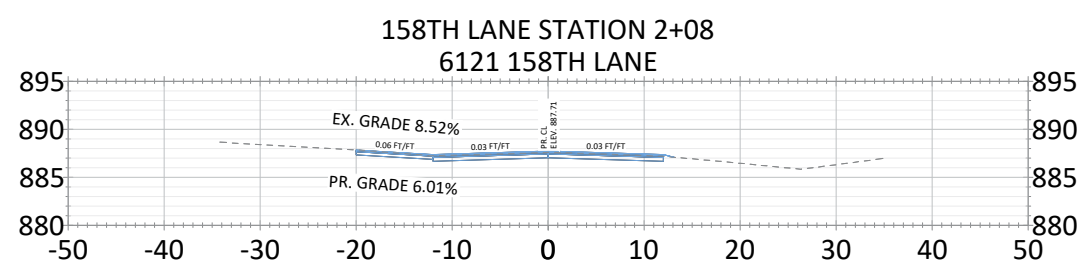
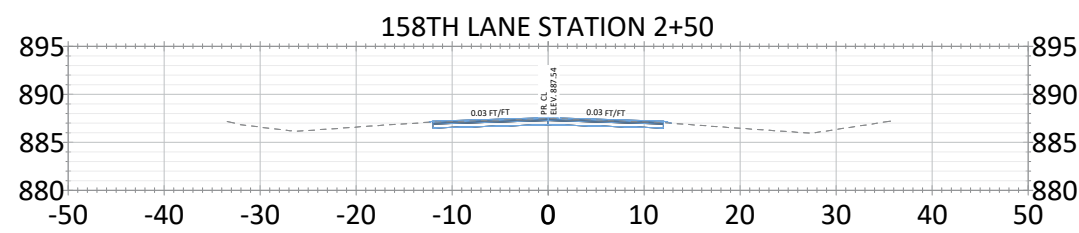
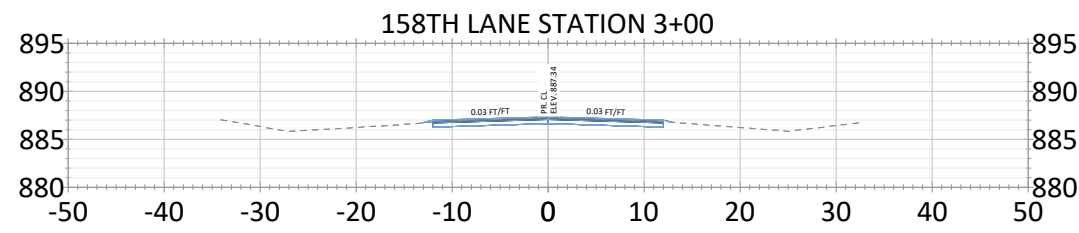

DATE	REVISION

I hereby certify that this plan, specification, or report was prepared by me or under my direct supervision and that I am a duly Licensed Professional Engineer under the laws of the State of Minnesota

JOE FERIANECK
Date 1/23/24 Lic. No. 57095

DESIGNED BY: JJF
DRAWN BY: JJF
CHECKED BY: BRW

DATE: 12/15/23
FILE: 24-02

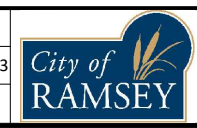

CITY OF RAMSEY
7550 SUNWOOD DRIVE
RAMSEY, MN 55303
(763) 427-1410 FAX (763) 433-9898

CROSS SECTIONS
158TH LANE

HALLS DOVER ACRES STREET RECONSTRUCTIONS
CITY PROJECT NO. 24-02
CITY OF RAMSEY, MINNESOTA

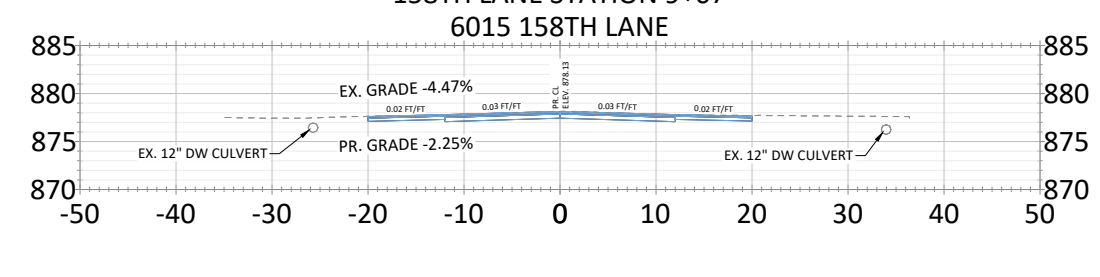
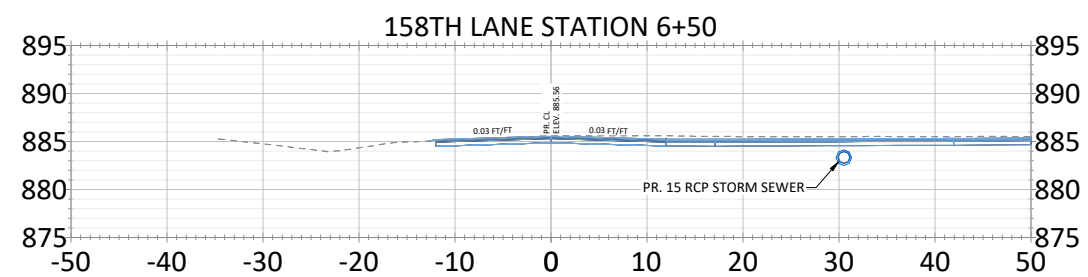
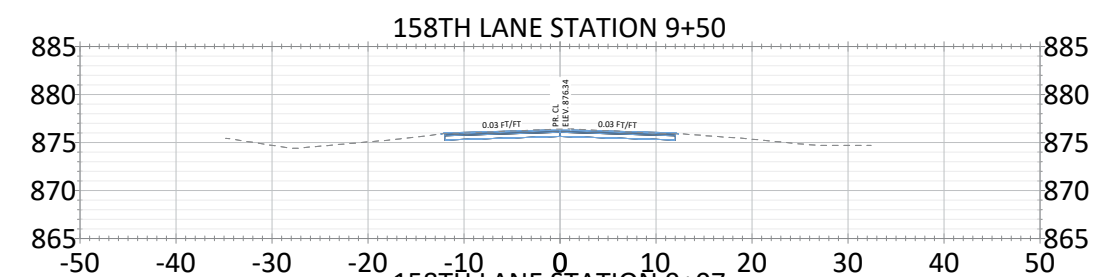
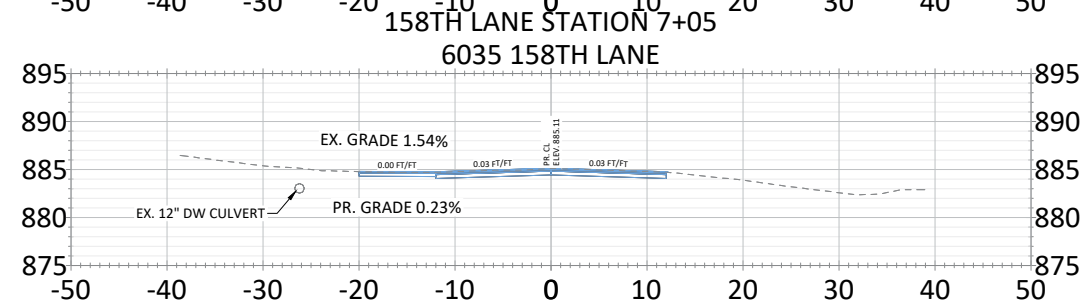
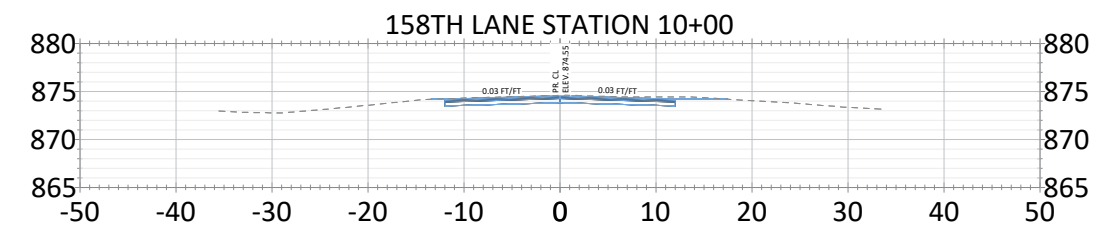
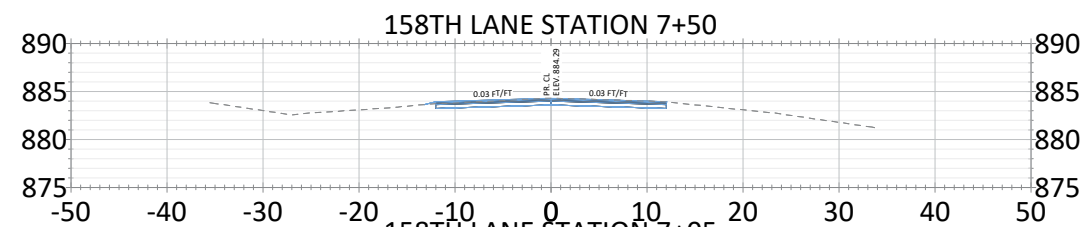
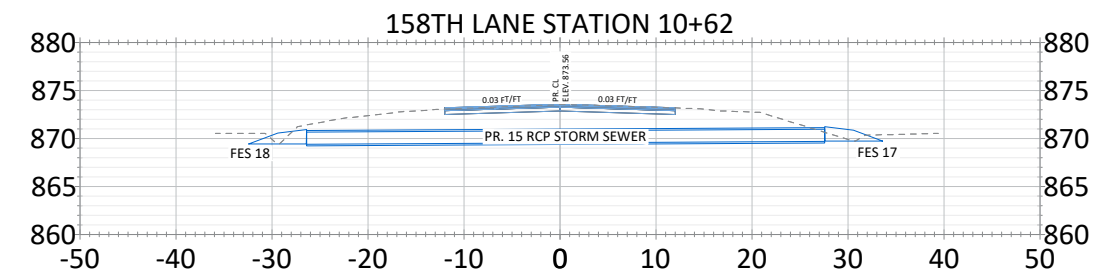
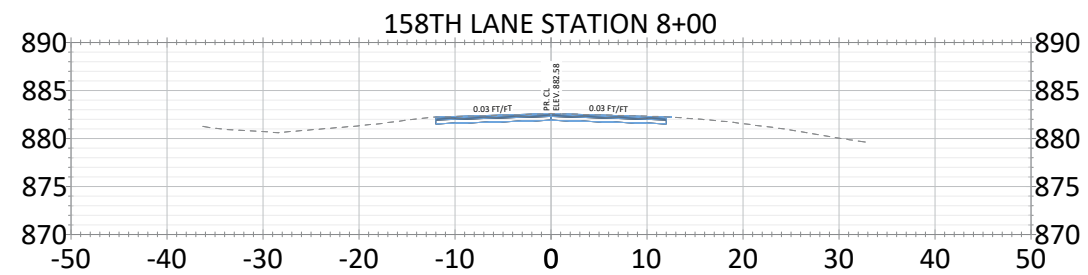
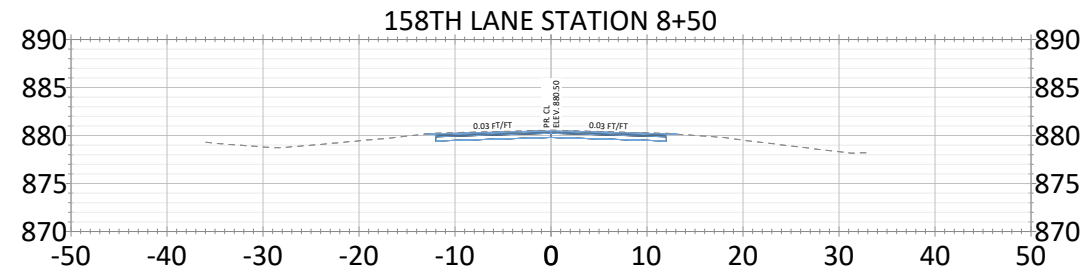
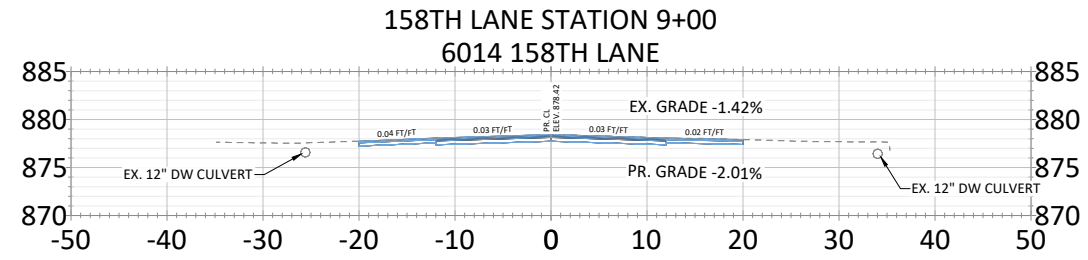

DATE	REVISION

I hereby certify that this plan, specification, or report was prepared by me or under my direct supervision and that I am a duly Licensed Professional Engineer under the laws of the State of Minnesota

JOE FERIANCEK
Date 1/23/24 Lic. No. 57095

DESIGNED BY: JJF
DRAWN BY: JJF
CHECKED BY: BRW

DATE: 12/15/23
FILE: 24-02

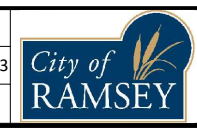

CITY OF RAMSEY
7550 SUNWOOD DRIVE
RAMSEY, MN 55303
(763) 427-1410 FAX (763) 433-9898

CROSS SECTIONS
158TH LANE

HALLS DOVER ACRES STREET RECONSTRUCTIONS
CITY PROJECT NO. 24-02
CITY OF RAMSEY, MINNESOTA

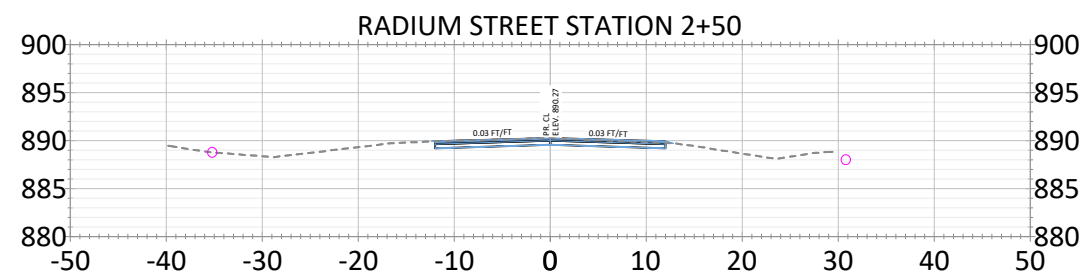
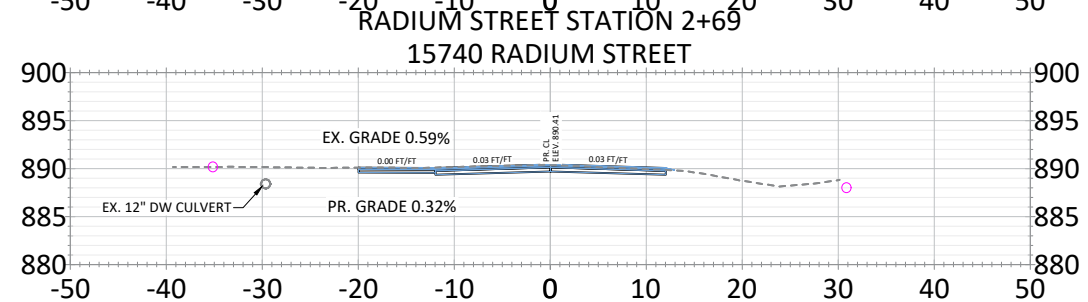
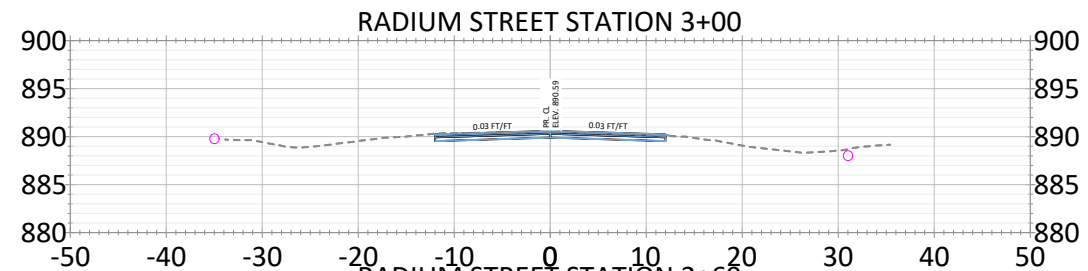
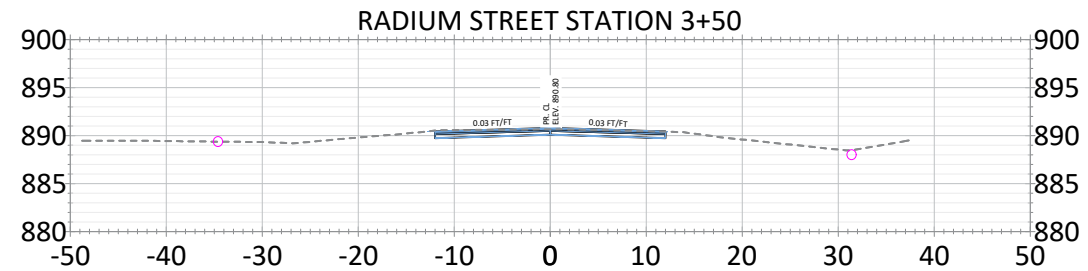
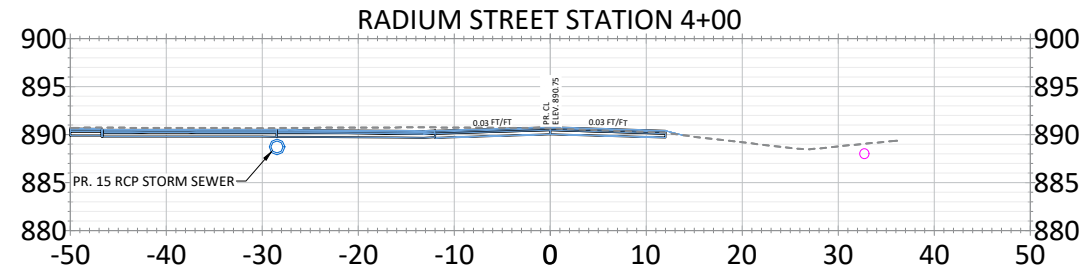
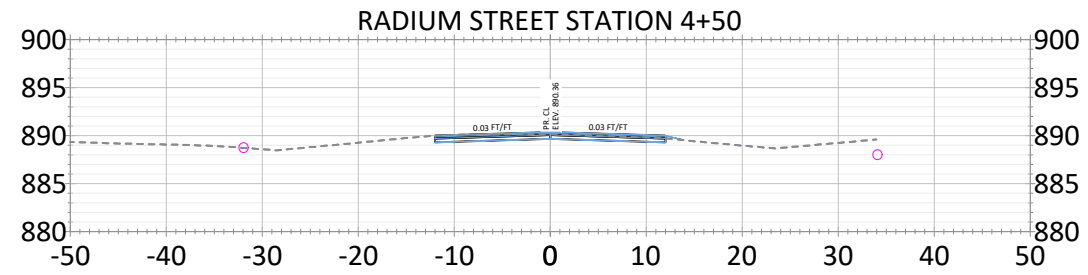
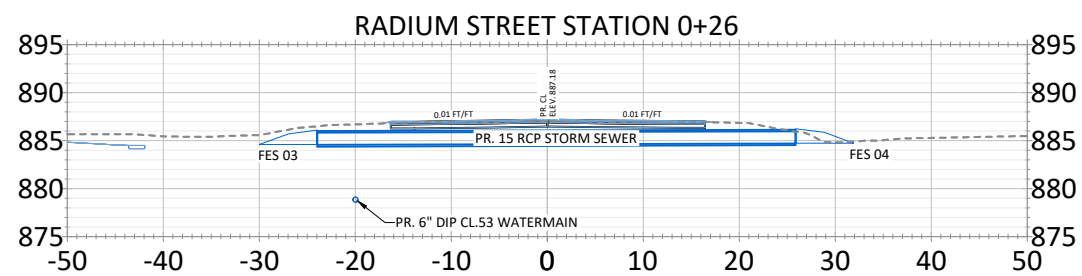
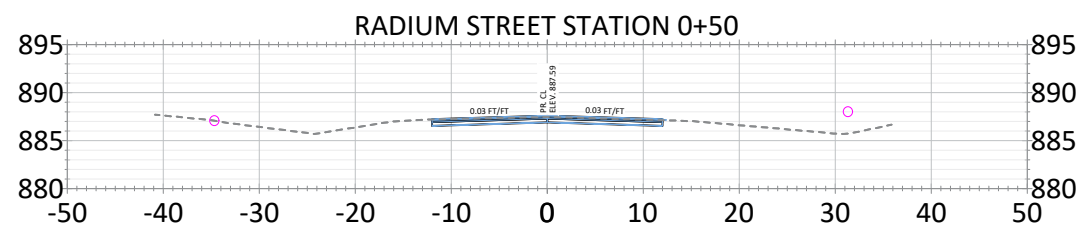
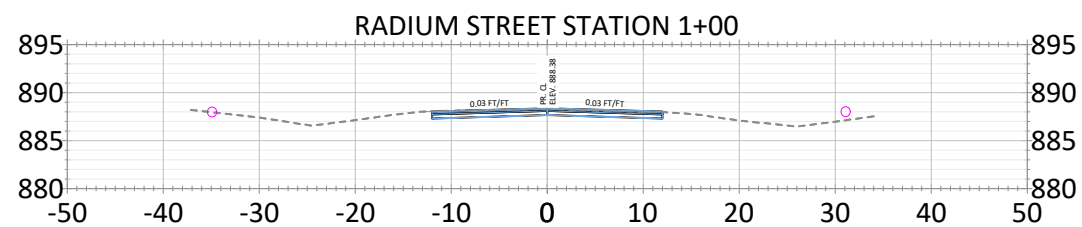
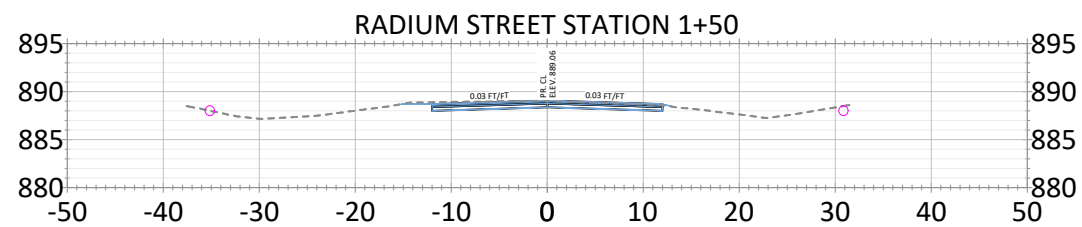
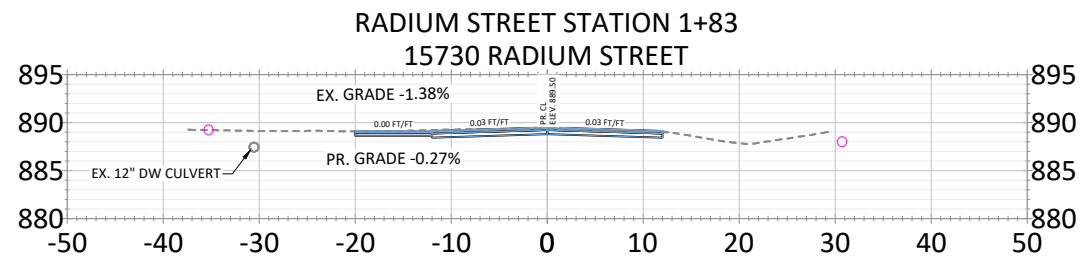
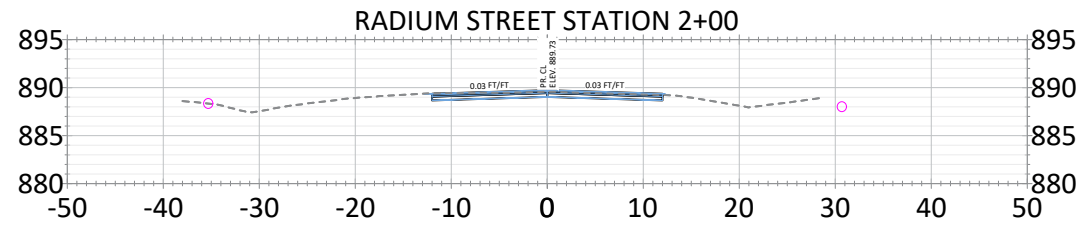

DATE	REVISION

I hereby certify that this plan, specification, or report was prepared by me or under my direct supervision and that I am a duly Licensed Professional Engineer under the laws of the State of Minnesota

JOE FERIANCEK
Date 1/23/24 Lic. No. 57095

DESIGNED BY: JJF
DRAWN BY: JJF
CHECKED BY: BRW

DATE: 12/15/23
FILE: 24-02

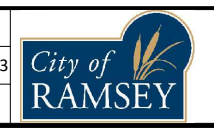

CITY OF RAMSEY
7550 SUNWOOD DRIVE
RAMSEY, MN 55303
(763) 427-1410 FAX (763) 433-9898

CROSS SECTIONS
RADIUM STREET

HALLS DOVER ACRES STREET RECONSTRUCTIONS
CITY PROJECT NO. 24-02
CITY OF RAMSEY, MINNESOTA

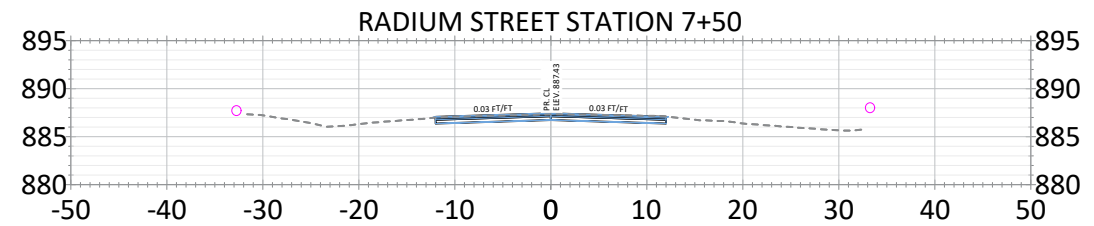
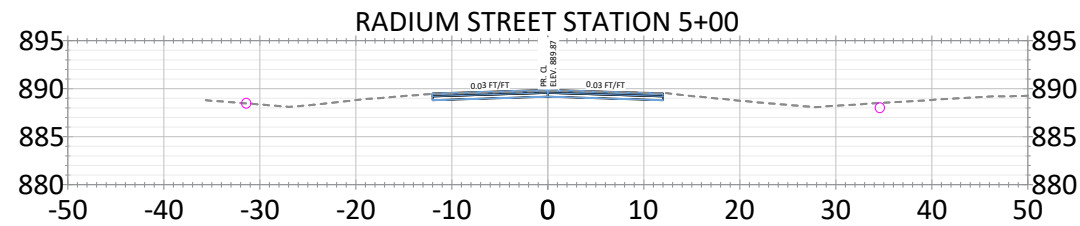
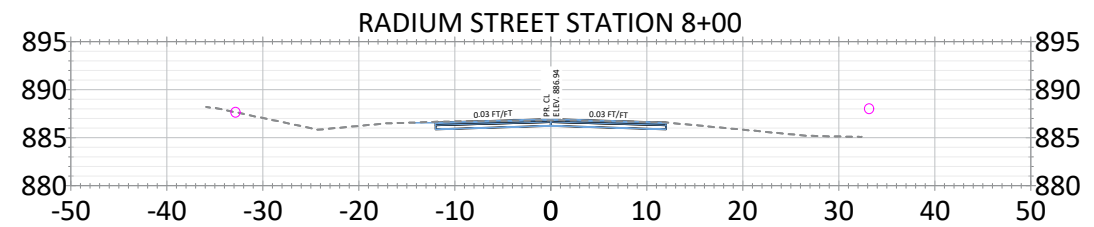
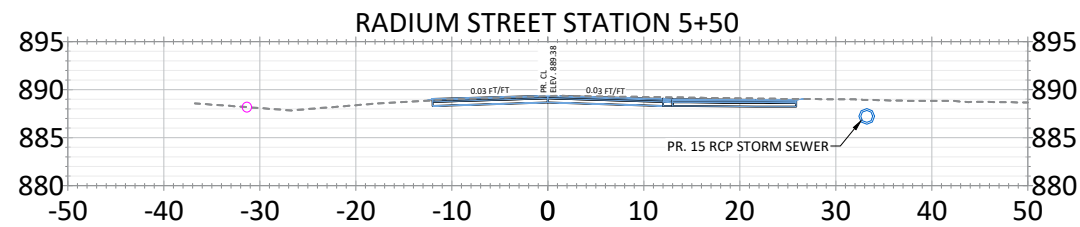
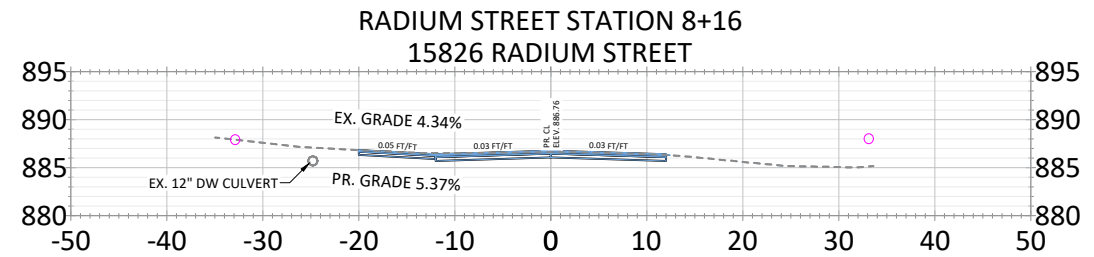
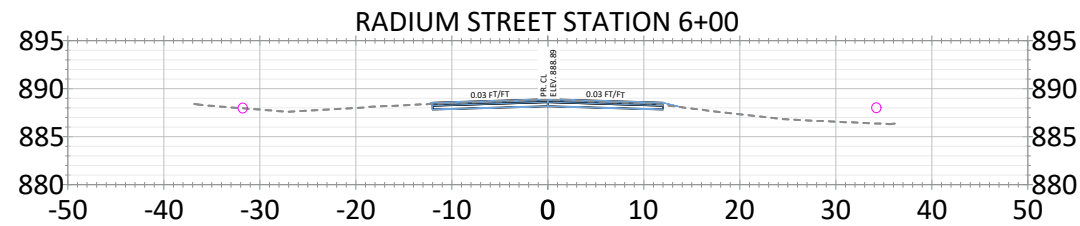
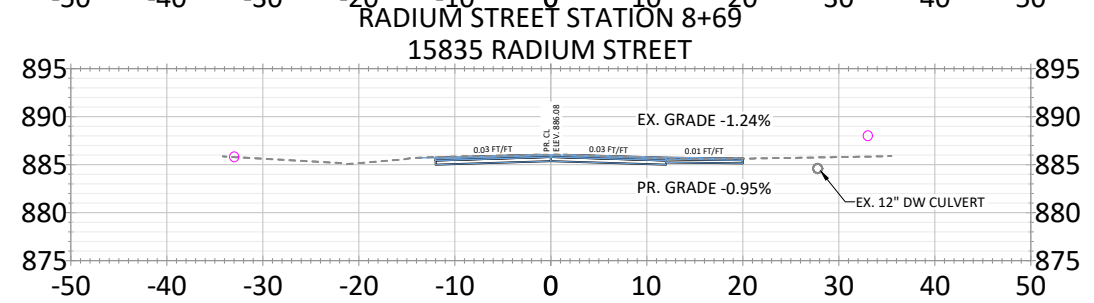
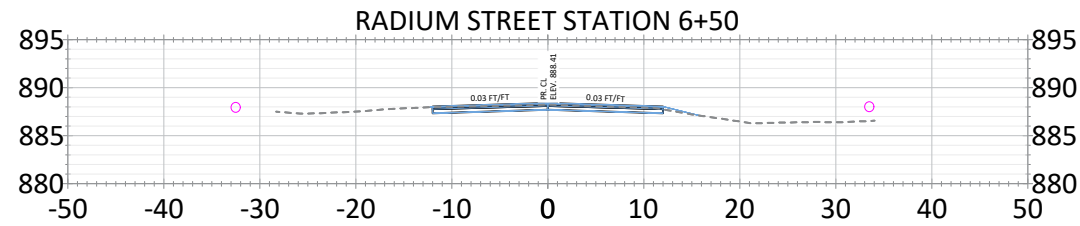
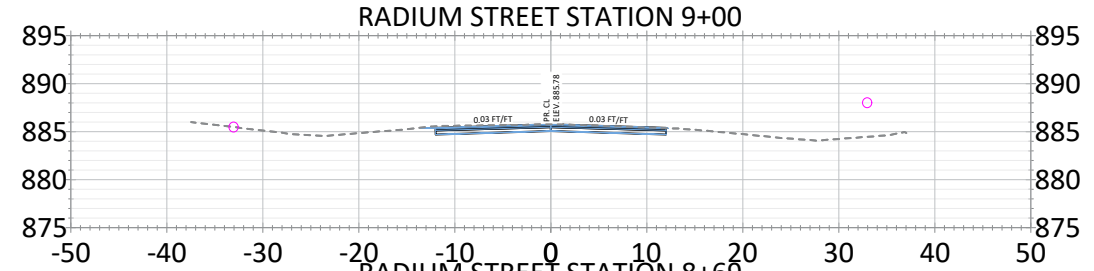
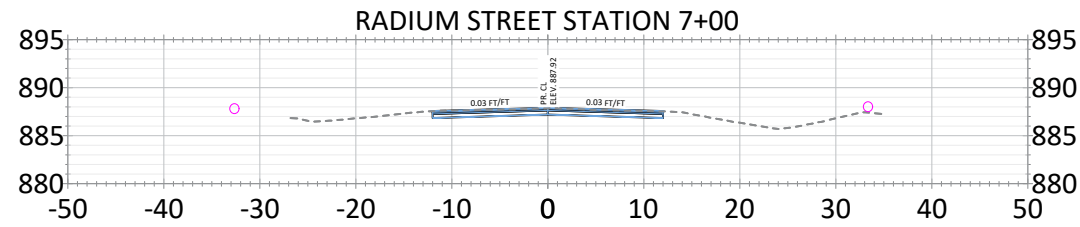
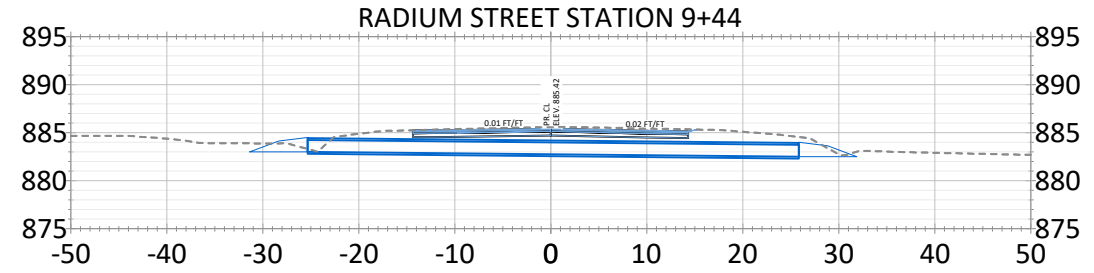
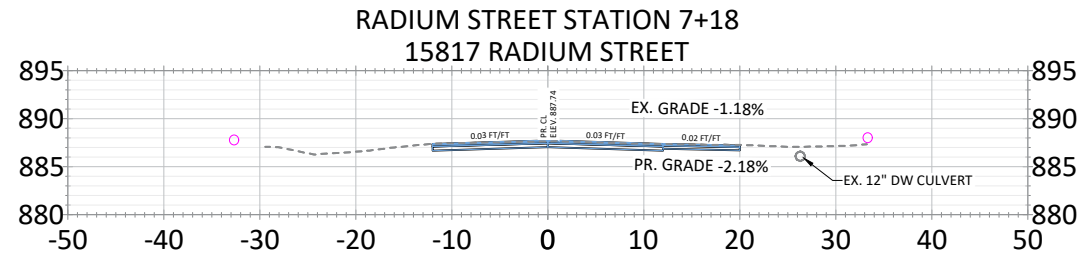

DATE	REVISION

I hereby certify that this plan, specification, or report was prepared by me or under my direct supervision and that I am a duly Licensed Professional Engineer under the laws of the State of Minnesota

JOE FERIANCEK
Date 1/23/24 Lic. No. 57095

DESIGNED BY: JJF
DRAWN BY: JJF
CHECKED BY: BRW

DATE: 12/15/23
FILE: 24-02

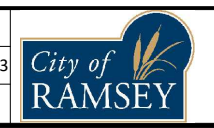

CITY OF RAMSEY
7550 SUNWOOD DRIVE
RAMSEY, MN 55303
(763) 427-1410 FAX (763) 433-9898

CROSS SECTIONS
RADIUM STREET

HALLS DOVER ACRES STREET RECONSTRUCTIONS
CITY PROJECT NO. 24-02
CITY OF RAMSEY, MINNESOTA

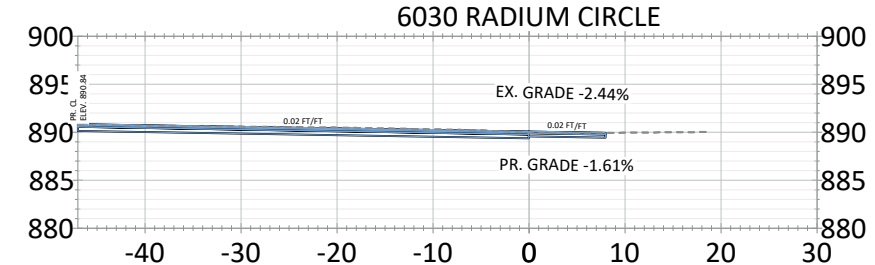
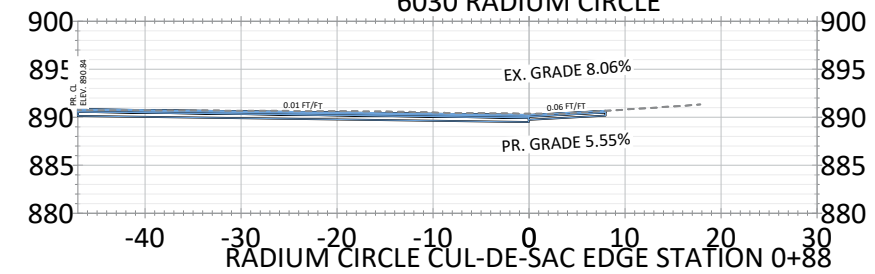
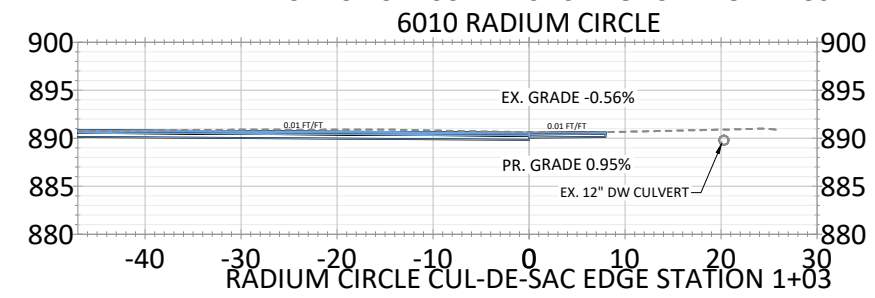
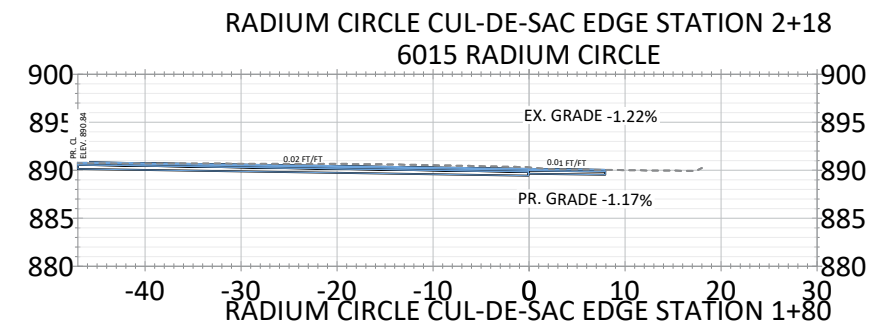
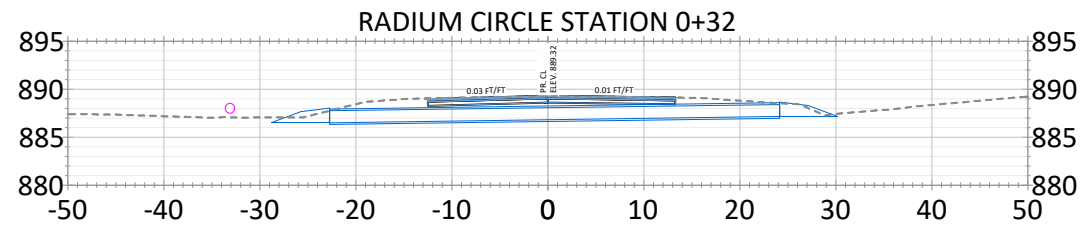
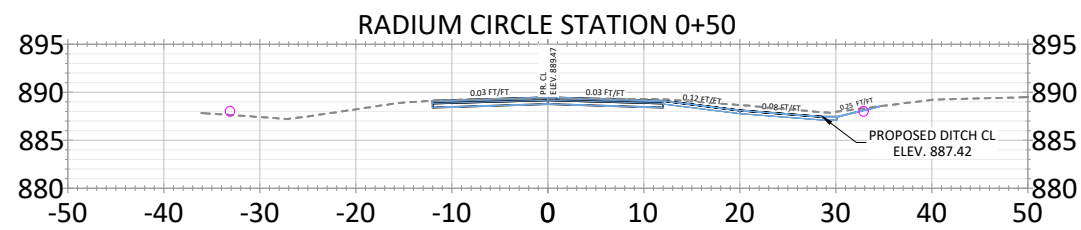
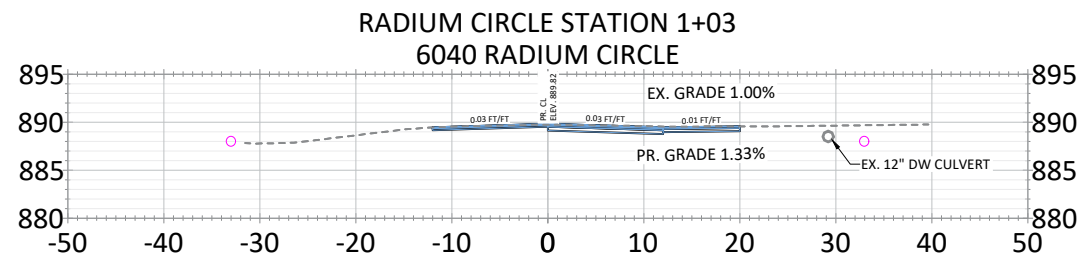
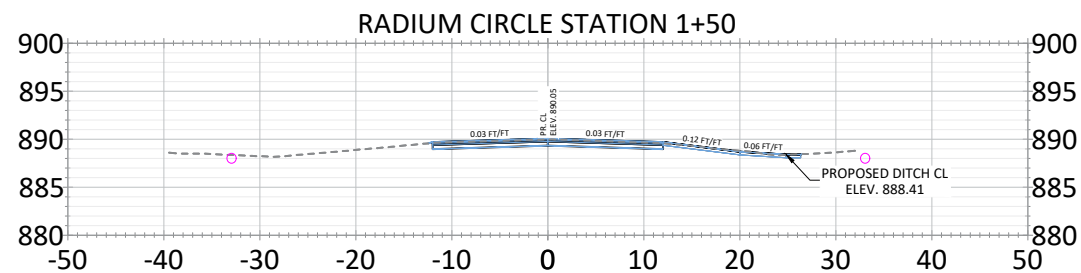
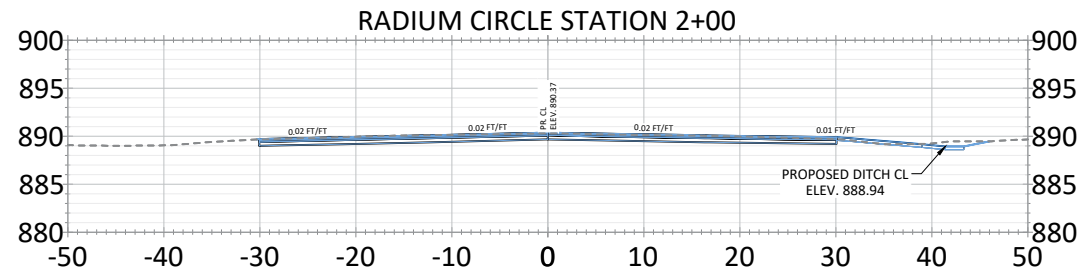
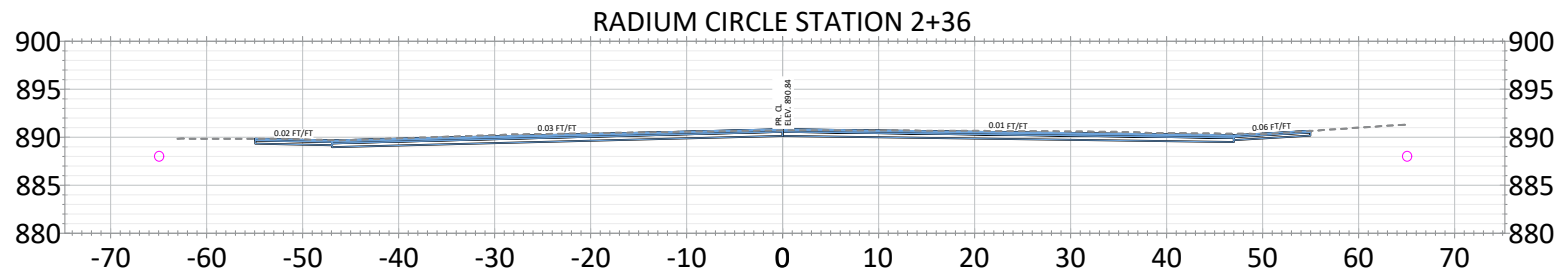

DATE	REVISION

I hereby certify that this plan, specification, or report was prepared by me or under my direct supervision and that I am a duly Licensed Professional Engineer under the laws of the State of Minnesota

JOE FERIANCEK
Date 1/23/24 Lic. No. 57095

DESIGNED BY: JJF
DRAWN BY: JJF
CHECKED BY: BRW

DATE: 12/15/23
FILE: 24-02

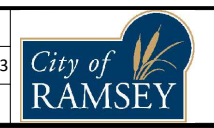

CITY OF RAMSEY
7550 SUNWOOD DRIVE
RAMSEY, MN 55303
(763) 427-1410 FAX (763) 433-9898

CROSS SECTIONS
RADIUM CIRCLE

HALLS DOVER ACRES STREET RECONSTRUCTIONS
CITY PROJECT NO. 24-02
CITY OF RAMSEY, MINNESOTA

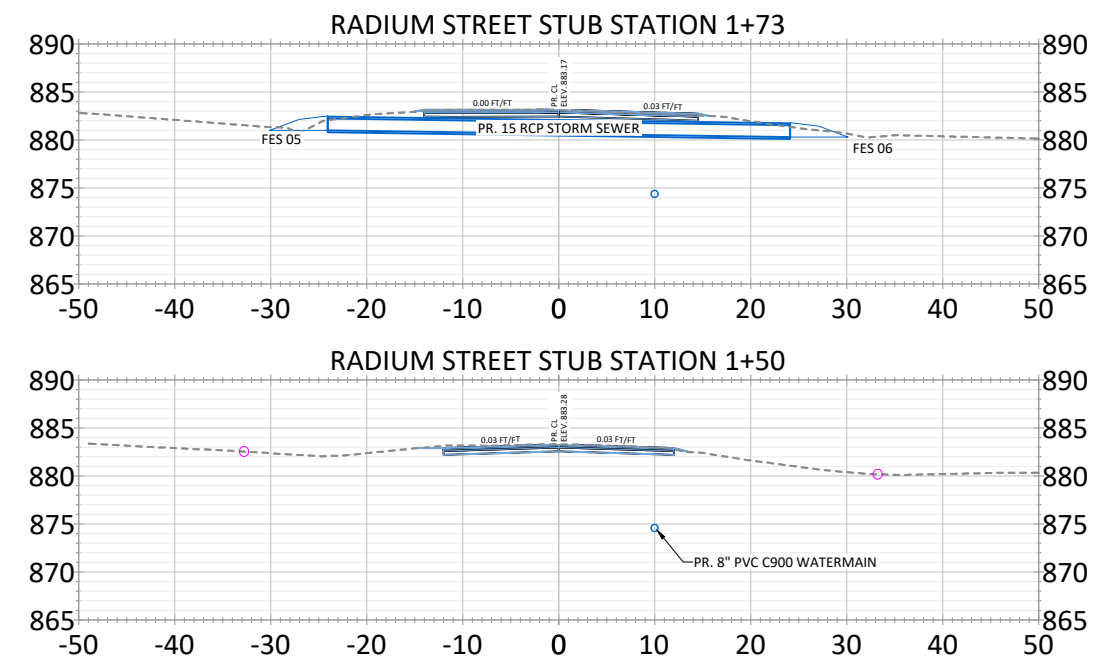
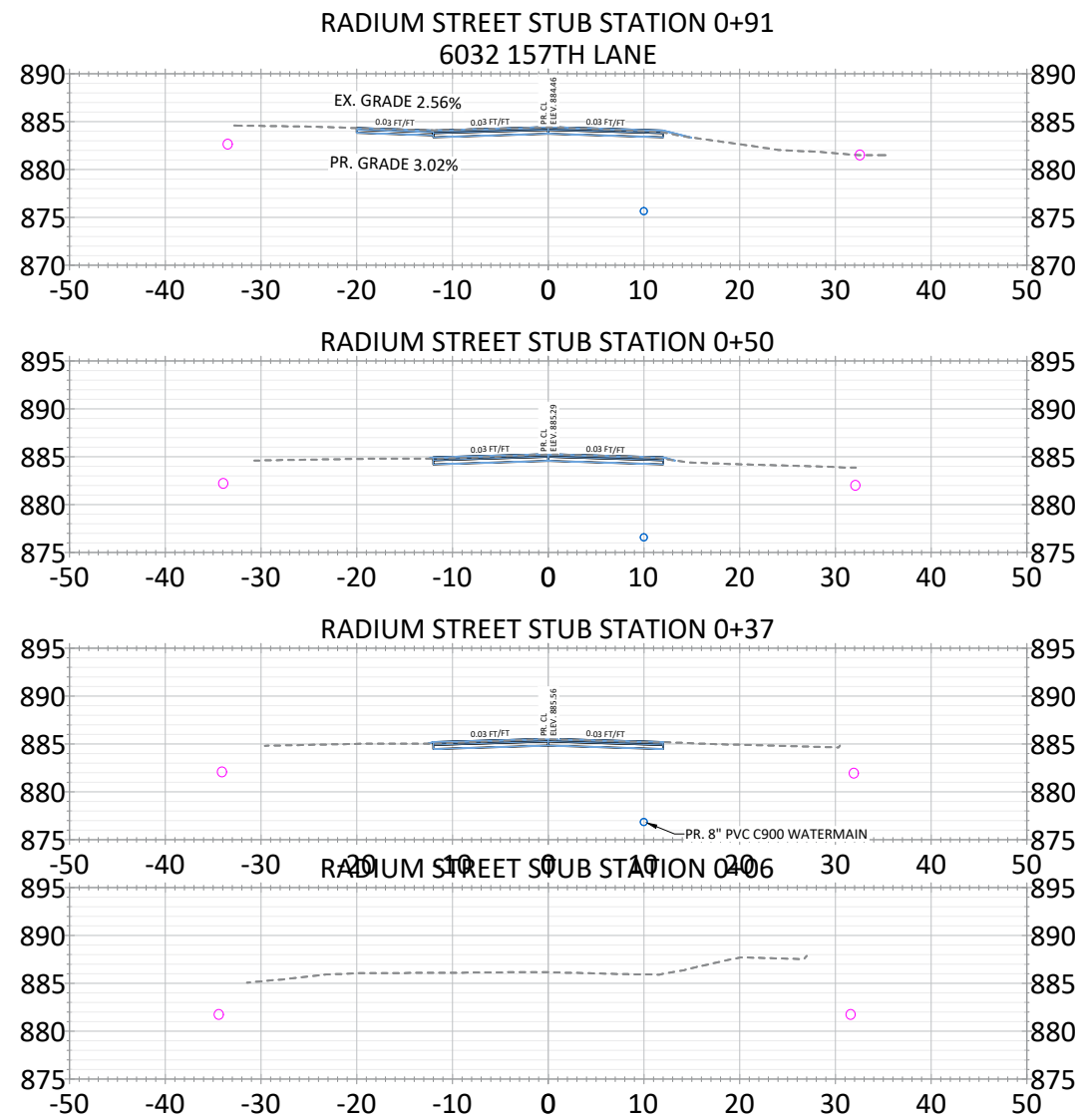

DATE	REVISION

I hereby certify that this plan, specification, or report was prepared by me or under my direct supervision and that I am a duly Licensed Professional Engineer under the laws of the State of Minnesota

JOE FERIANCEK
Date 1/23/24 Lic. No. 57095

DESIGNED BY: JJF
DRAWN BY: JJF
CHECKED BY: BRW

DATE: 12/15/23
FILE: 24-02

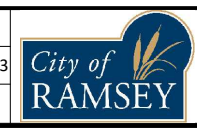

CITY OF RAMSEY
7550 SUNWOOD DRIVE
RAMSEY, MN 55303
(763) 427-1410 FAX (763) 433-9898

CROSS SECTIONS
RADIUM STREET STUB

HALLS DOVER ACRES STREET RECONSTRUCTIONS
CITY PROJECT NO. 24-02
CITY OF RAMSEY, MINNESOTA