

1. Standard Reflectance of 80/50/20 unless noted otherwise
2. Not a Construction Document, for Design purposes only
3. Standard indoor calc points @ 30' A.F.F. unless noted otherwise
4. Standard outdoor calc points @ Grade unless noted otherwise
5. Egress calc points @ 0' A.F.F.
6. Mlazar Associates assumes no responsibility for installed light levels due to field conditions, etc.

Calculation Summary						
Label	CalcType	Units	Avg	Max	Min	Avg/Min
CalcPts_1	ILLUMINANCE	Fc	0.28	8.9	0.0	N.A.
PROPERTY LINE	ILLUMINANCE	Fc	0.01	0.2	0.0	N.A.

Luminaire Schedule						
Symbol	Qty	Label	Manufacturer	Description	Arrangement	Lum. Lumens
○	10	OA		3-751	Single	808
○	1	SP1		PRV-PA1A-740-U-T4W	Single	7484
○	2	SP2		PRV-PA1B-740-U-T4W	Single	9738
○	4	SP3		PRV-PA2B-740-U-T4W	Single	19431
○	2	SP5		PRV-PA2B-740-U-5WQ	Single	20332
						Lum. Watts
						20.4
						54
						74
						151
						151
						LLF
						0.900
						0.900
						0.900
						0.900

#	Date	Comments
Revisions		

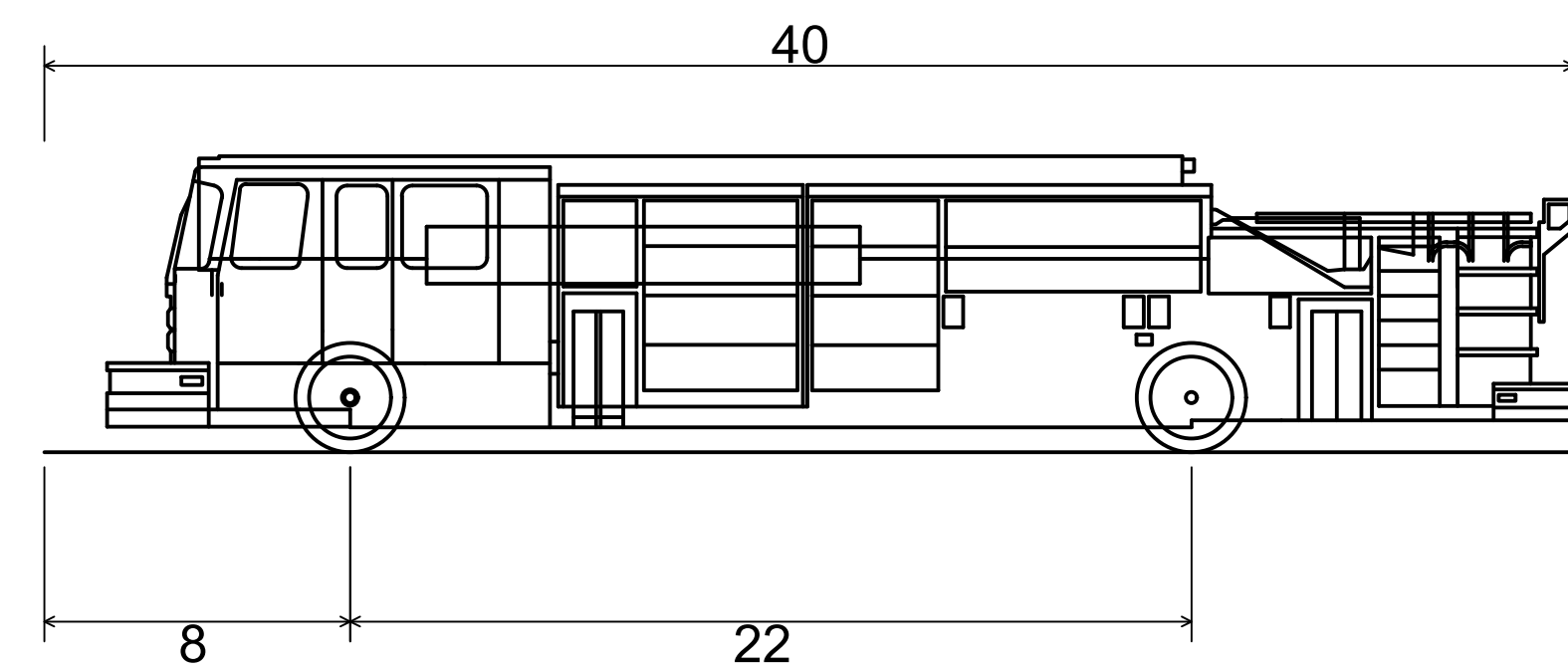
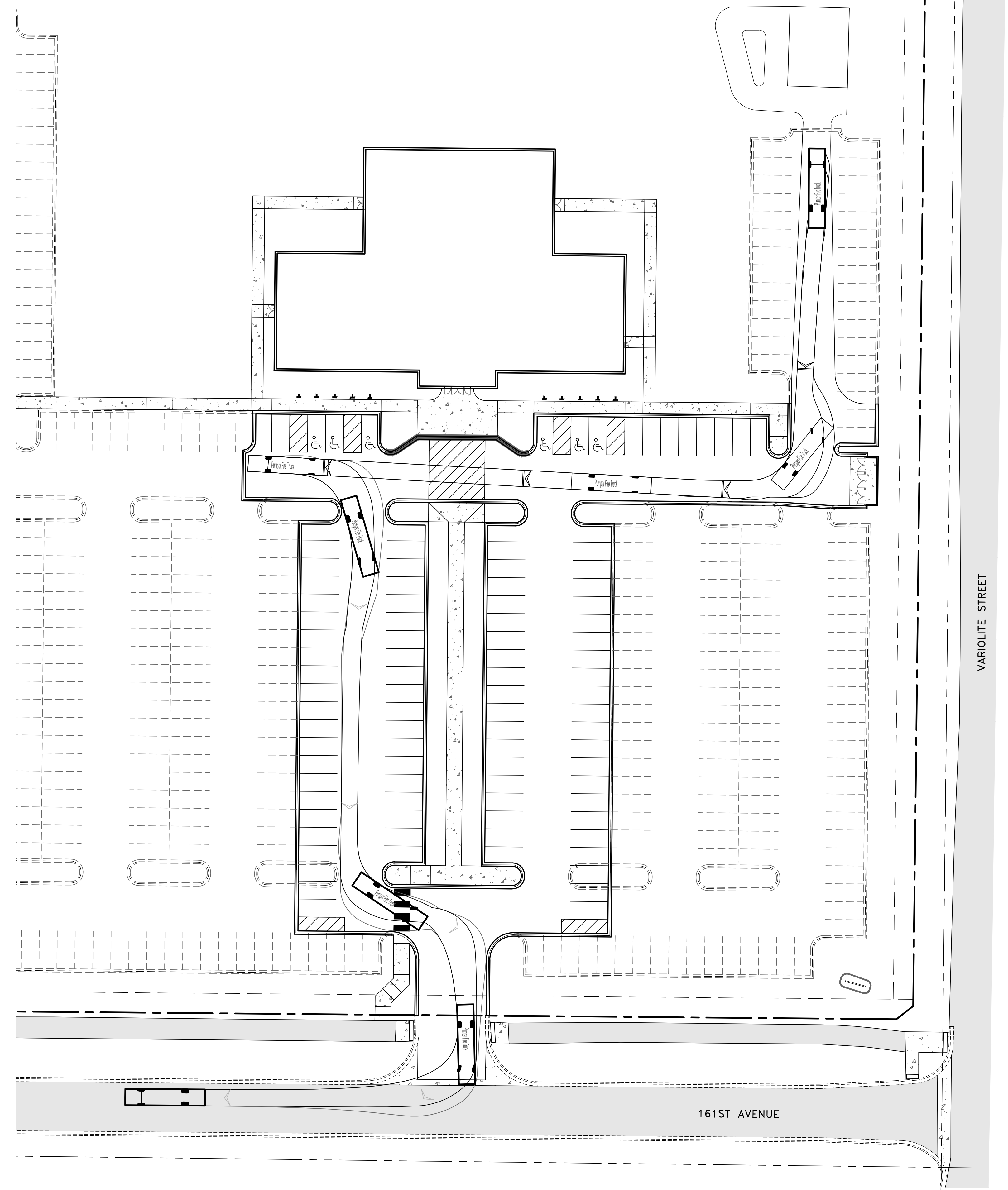
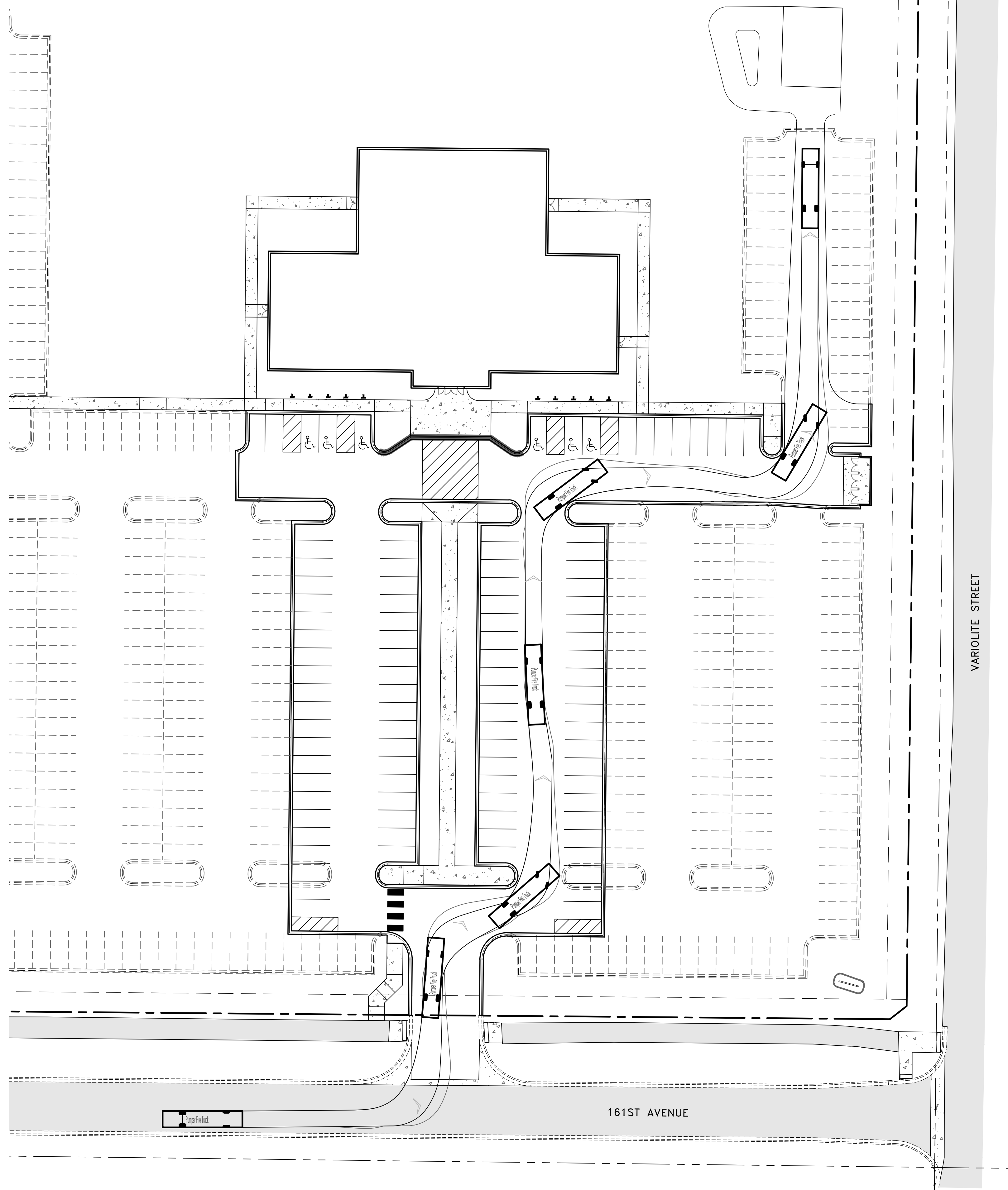

Pumper Fire Truck
 Overall Length 40.000ft
 Overall Width 8.167ft
 Overall Body Height 7.745ft
 Min Body Ground Clearance 0.656ft
 Track Width 8.167ft
 Lock-to-lock time 5.00s
 Max Wheel Angle 45.00°

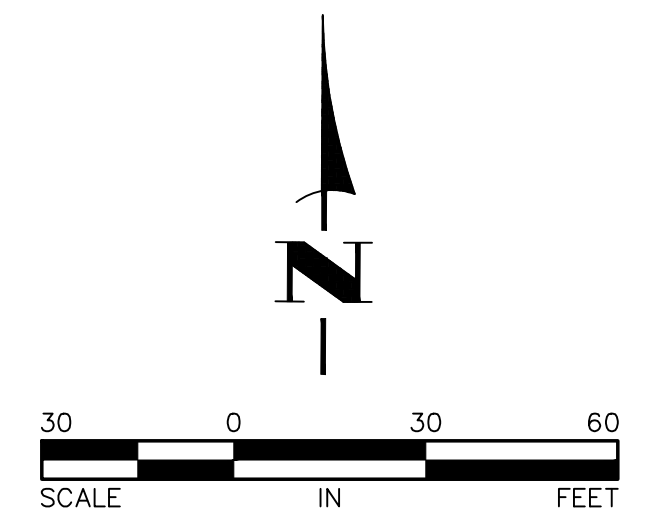

No. 1 - 2024 - 10-25-24
 K:\PROJECTS\19_02_COUNCILING\EXHIBITS\471902_FIRE_TRUCK_TURNING_EXHIBIT.dwg



Hakanson Anderson
 Civil Engineers and Land Surveyors
 3601 Thurston Ave., Anoka, Minnesota 55303
 763-427-5860 FAX 763-427-0520
www.hakanson-anderson.com

ST. KATHARINE DREXEL

FIRE TRUCK TURNING EXHIBIT

CITY OF RAMSEY, MINNESOTA

SHEET
 1 OF 1
 SHEETS
 4719.02

PLANTING DETAILS

LANDSCAPE SPECIFICATIONS

TREES, SHRUBS, AND PERENNIALS

- REFERENCES
 - A. MnDOT - Minnesota Department of Transportation, Standard Specifications for Construction, 2020 Edition.
 - B. American Standard for Nursery Stock, ANSI Z60.1-2014.
 - C. ASTM, American Society for Testing and Materials.
- QUALITY ASSURANCE
 - A. Work shall be performed by a landscape contractor with extensive horticulture knowledge, and a min. of 3 years of experience.
 - B. Handle plants in such a way as to protect from damage either physical or by exposure to sun and wind. Mishandled plants are subject to rejection by Landscape Architect.
 - C. Plants used on this project shall meet the grading standards recommended by the ANSI Z60.1-2014.
- PRODUCTS
 - A. Plants: Provide as specified on Plant Schedule. ANY SPECIES SUBSTITUTIONS REQUIRE PRIOR APPROVAL BY THE CITY OF RAMSEY.
 - B. Edging: Steel edging: 3/16" x 4" w/ 15" stakes, black color, Sure-loc or equal.
 - C. Mulch: Shredded hardwood mulch.
 - D. Water: Contractor to provide.
 - E. Planting Soil: rich friable, loam topsoil, free of debris and seeds, conforming to MnDOT 3877.2, Loam Topsoil Borrow with not more than 35% sand content.
 - F. Compost: Conforming to MnDOT 3890.2, Grade 2.
 - G. Tree Wrap: Two-ply weather resistant paper product.
- PLANTING DATES: Spring Planting: Apr. 1 - June 15. These dates may be extended if daytime temps. remain below 80 degrees. Fall: Sept. 30 - Oct. 30th. Daytime temps. need to drop below 80 degrees before planting begins, and may continue until freeze up. Coniferous trees Aug. 15 - Oct. 1st. Plant under favorable weather conditions, do not plant during days of extreme heat.

- EXECUTION
 - A. Prior to digging, Contractor to have utilities located.
 - B. Contractor to notify Owner and Landscape Architect 3 days in advance of when planting work will occur.
 - C. Plant into prepared planting beds.
 - D. Install trees, shrubs, and perennials per planting details, adjust location if in conflict with utilities. Verify new location with Landscape Architect prior to planting.
 - E. Separate all shrub and perennial beds from sod areas with edger.
 - F. Clean-up entire site following planting operations.
- ACCEPTANCE OF PLANTING WORK
 - A. Contractor to notify Owner when planting work is complete for review and punch list.
 - B. Contractor to water and maintain the trees, shrubs, and perennials until Owner Acceptance.
 - C. Owner will give Acceptance of Work following satisfactory correction of punch list items.
 - D. Watering and regular landscape maintenance of trees, shrubs, and perennials will be Owners responsibility following acceptance of work.
- GUARANTEE PERIOD
 - A. Contractor to warranty trees, shrubs and perennials for **2-years** following acceptance of Work by Owner.
 - B. Contractor to maintain the trees in a plumb position throughout the guarantee period.
 - C. Contractor to remove all staking/wiring/ straps and plant tags from trees at the end of the guarantee period.
 - D. Replacements: At the end of the guarantee period, all plants which are unhealthy, dead, not having a normal density, size, shape or color shall be replaced. Replacements shall match caliper and/or height of the other plants at time of replacement. Selection of replacement material and installation practices shall follow the requirements of the Drawings and Specifications.

SODDING

- AREAS TO SOD
 - A. Sod areas as shown on plan.
- REFERENCES
 - A. MnDOT - Minnesota Department of Transportation, Standard Specifications for Construction, 2020 Edition.
- PRODUCTS
 - A. Sod: Provide drought tolerant, strongly rooted sod, machine cut to pad thickness of 1", excluding top growth and thatch. Sod to be at least 2 years old, free of weeds, disease, or other material which might be detrimental to the development of the sod. Sod to be moist when cut and maintained in moist condition during transportation and storage at the site. Do not use sod that shows signs of visible heating on this project.
 - B. Fertilizer: Slow release 5-10-5 starter fertilizer.
 - C. Water: Contractor to provide.
 - D. Topsoil: provide rich friable loam, free of debris and seeds, and conforming to MnDOT 3877.2 Common Topsoil Borrow with not more than 35% sand content.
- SOIL PREPARATION
 - A. ALL DISTURBED AREAS NOT OTHERWISE IMPROVED WITH IMPERVIOUS SURFACING, REQUIRES 4" OF TOPSOIL WITH NOT MORE THAN 35% SAND CONTENT.
 - B. Immediately prior to sodding, loosen topsoil to minimum depth of 3".
 - C. On slopes operate cultivating equipment at right angles to the direction of surface drainage.
 - D. Contractor to work all areas to receive sod until the soil is smooth and an even grade is established. Fill all holes, depressions and riviets to ensure an even grade and that proper elevation is established. Fill material shall be compacted sufficiently to provide uniform density and to resist erosion. Remove all rubble, sticks, branches, stones and other extraneous material over 1/2" in diameter on the surface prior to sodding.
 - E. For all areas to be sodded work in dry, free flowing slow release starter fertilizer into the top 1 inch of soil.
- EXECUTION
 - A. Install sod during favorable weather, do not sod if ground is frozen or sod is dormant.
 - B. Lay sod with tightly fitting joints, no overlapping joints, and stagger rows to offset joints. Anchor sod on slopes to prevent slippage.
 - C. Thoroughly water sod immediately after installing. Continue watering at frequency necessary to initiate rooting, and until the work is accepted by Owner.
 - D. Clean up and remove all debris resulting from sodding activity and dispose of properly. Restore all areas disturbed by sodding operation to their original condition.
- ACCEPTANCE OF SOD WORK
 - A. Contractor to notify Owner when sod work is complete for review and punch list.
 - B. Owner to accept work following satisfactory correction of punch list items.
 - C. Contractor will maintain all turf areas in a healthy, growing condition by watering, mowing, and any other maintenance necessary to establish the lawn, for a minimum of 30 days from time of acceptance.
 - D. Any sod that does not show definite growth and establishment during the 30 days from time of acceptance, shall be replaced and established at the proper season by the Contractor at Contractor's expense.

IRRIGATION

- DESCRIPTION
 - A. Work includes: design, furnish, and install complete, fully automatic and programmable underground irrigation system, capable of alternate date watering for all landscape areas identified on sheet L1. The system shall provide full coverage with uniform levels of total precipitation throughout all irrigated areas.
 - B. The system is to include water efficient technologies including: a WaterSense labeled controller, a flow meter, soil moisture and/or evapotranspiration (ET) sensors, a rain sensor, and be calibrated to meet all applicable City Codes.
 - C. Dripline to be used in perennial and shrub beds not covered by lawn sprinklers.
 - D. The system is to meet state department of health standards and have a backflow preventer.
 - E. Materials, equipment, and methods of design and installation shall comply with, but not be limited to, the following codes and standards:
 - All local and state laws and ordinances, and with all the established codes applicable thereto.
 - National Electrical Code.
 - American Society for Testing and Materials (ASTM).
 - National Sanitation Foundation (NSF).
 - The best management practices developed by the Irrigation Association.
 - F. The designer shall provide balanced pressure and flow and optimum operating efficiency.
 - G. The contractor is responsible for obtaining all permits and licenses required for installation of irrigation system.
- QUALITY ASSURANCE
 - A. The irrigation system shall be designed and installed by a contractor specializing in irrigation work, and will have a minimum of 5 years of experience designing and installing systems of similar scope and size.
 - B. The contractor shall maintain a skilled foreman on site during the installation of all work and the foreman will have a Minnesota Power Limited Technician License.
- SUBMITTALS
 - A. Shop Drawings: submit irrigation plan, product schedule, and specifications for review and acceptance.
 - B. Operation and Maintenance Manual: following completion of work, provide the Owner with an operation and maintenance manual of the complete system in a digital pdf file format and one hard copy.
 - C. As-Built Plan: following completion of work, contractor to furnish Owner a scaled as-built irrigation map, with dimensions as needed, on durable paper or laminated to be mounted on wall with the main control panel and a digital file in pdf format. The map shall indicate the zones, location of all controls, piping and depths, heads (including type), drip-lines, valves, connection to water service, and other related components.
- PRODUCTS
 - A. Select products suitable to the landscape areas.
 - B. All products and materials used in the system shall be new and professional grade.
 - C. Provide sprinkler heads, driplines, electric valves, and automatic controller from one manufacturer: Toro, Rainbird, Hunter Industries, or equal.
- EXECUTION
 - A. Prior to digging, contractor to have utilities located.
 - B. Water Coverage: Provide uniform water coverage over sod areas, planting beds, and trees outside of sod areas.
 - C. Sod: Sod areas to be irrigated with spray heads. Locate heads to avoid overspray onto sidewalks, parking areas, signs and buildings.
 - D. Planting Beds: All continuous shrubs, trees, perennial beds to be irrigated with a drip system and spray heads where drip lines are impractical.
 - E. Trees: Trees outside of sod and planting beds to be irrigated.
 - F. Winterization: System to accommodate winterization by blowing system dry with compressed air.
 - G. Install the irrigation system per contractor's plan and specifications.
 - H. Instructions: Contractor to instruct the Owner in proper operation and maintenance of the system.
 - I. Cleanup: Replace landscaping disturbed by operations. Cleanup all debris and restore site to original condition.
- REVIEW AND ACCEPTANCE
 - A. Contractor to test system to a hydrostatic pressure of not less than 100 psi. Remove and replace any components that do not pass test.
 - B. Contractor to contact Owner and perform operational test after system is fully in place and demonstrate to the Owner that the irrigation system meets coverage requirements and that automatic controls function properly. Any corrective work identified shall be completed within two weeks of receipt of comments.
 - C. Owner to accept work following: satisfactory completion of any corrective work, receiving hands-on instructions for operation, and receiving as-built plan and operation and maintenance manual submittals.
- MAINTENANCE
 - A. Contractor to drain and winterize irrigation system in the fall, following first year of operation, and shall put the system back in service the following spring as part of the work of this contract at no additional cost to the Owner.
- GUARANTEE
 - A. Warranty irrigation system materials and labor for one year following acceptance of work by Owner. Contractor to promptly furnish and install, at no cost to Owner, any parts that prove defective in material or workmanship.

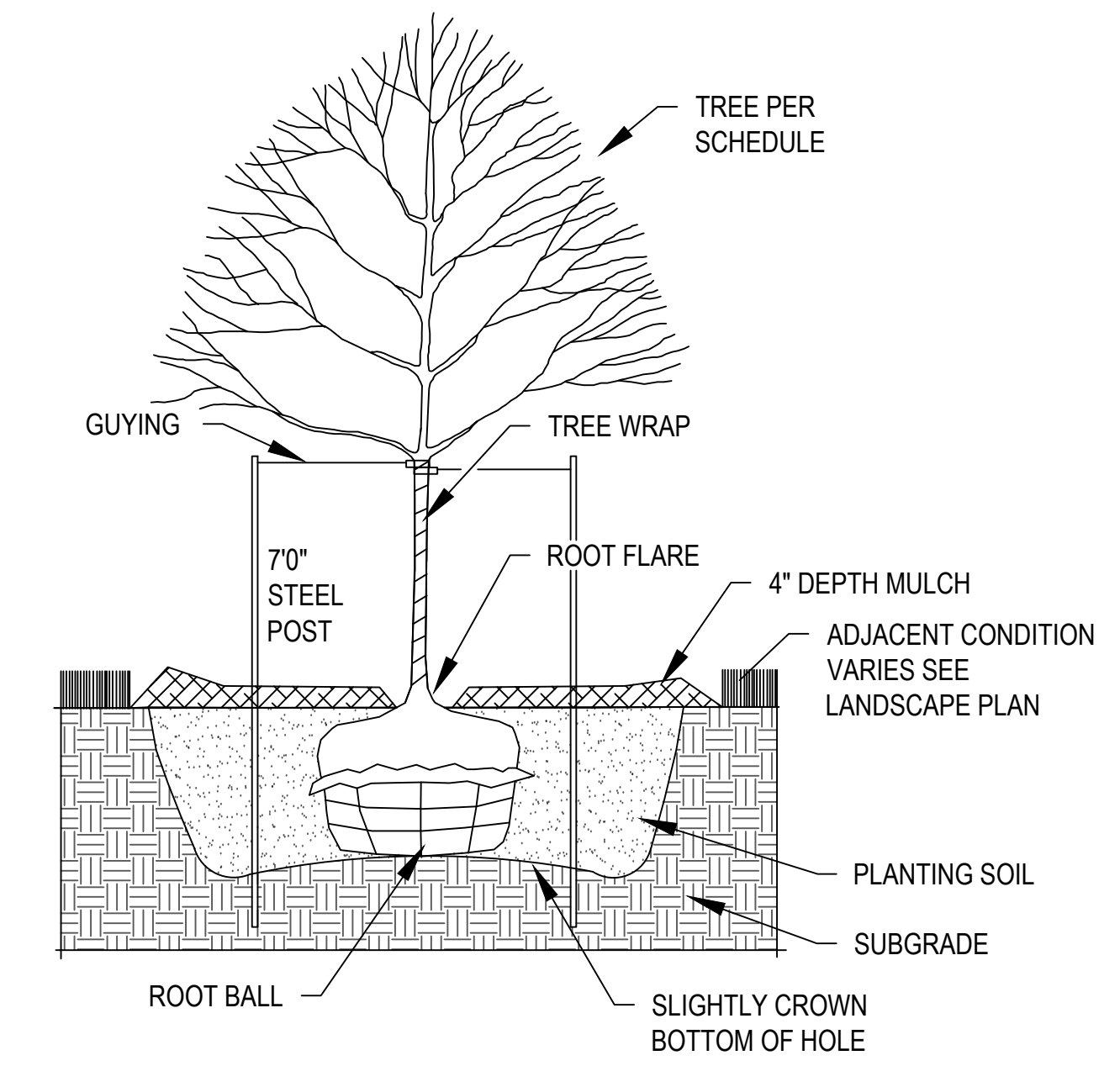

1
L2
TREE PLANTING DETAIL

- NOTES:
- REMOVE DEAD OR DAMAGED BRANCHES. RETAIN THE NATURAL FORM OF THE TREE. DO NOT CUT THE LEADER.
 - WIDTH OF PLANTING HOLES: 18" MIN. LARGER THAN ROOT BALL, ON ALL SIDES.
 - DEPTH OF HOLE: ROOT FLARE TO SIT AT, OR UP TO 2" ABOVE THE TOP OF THE FINISHED SOIL ELEVATION. LEAVE SOIL UNDISTURBED BENEATH THE ROOT BALL.
 - SCARIFY BOTTOM AND SIDES OF HOLE PRIOR TO PLANTING.
 - SET PLANT ON UNDISTURBED SOIL OR THOROUGHLY COMPACTED PLANTING SOIL.
 - REMOVE TOP 1/3 OF THE BASKET OR THE TOP TWO HORIZONTAL RINGS WHICHEVER IS GREATER. REMOVE ALL BURLAP FROM TOP 1/3 OF ROOT BALL. REMOVE ALL TWINE.
 - REMOVE OR CORRECT STEM GIRDLING ROOTS.
 - SLIT REMAINING BURLAP AT 6" INTERVALS.
 - PLUMB & BACKFILL WITH PLANTING SOIL AMENDED WITH COMPOST. THOROUGHLY WATER IN TREE WITHIN 2 HOURS TO SETTLE PLANTS AND FILL VOIDS.
 - BACKFILL VOIDS AND WATER A SECOND TIME.
 - PLACE 4" SHREDDED HARDWOOD MULCH WITHIN 48 HOURS OF THE SECOND WATERING. NO MULCH TO BE IN CONTACT W/ TRUNK.
 - CONTRACTOR IS RESPONSIBLE FOR MAINTAINING TREES IN A PLUMB POSITION THROUGHOUT THE GUARANTEE PERIOD. IF NEEDED, STAKE TREES USING 16" LONG, 1.5" WIDE STRAPS, AND ATTACH TO POST WITH WIRE. INSTALL POST 3' INTO GROUND. REMOVE WITHIN ONE YEAR.
 - WRAP TRUNK IN FALL REMOVE IN SPRING.
 - REFER TO SPECS. FOR ADDITIONAL INFORMATION.

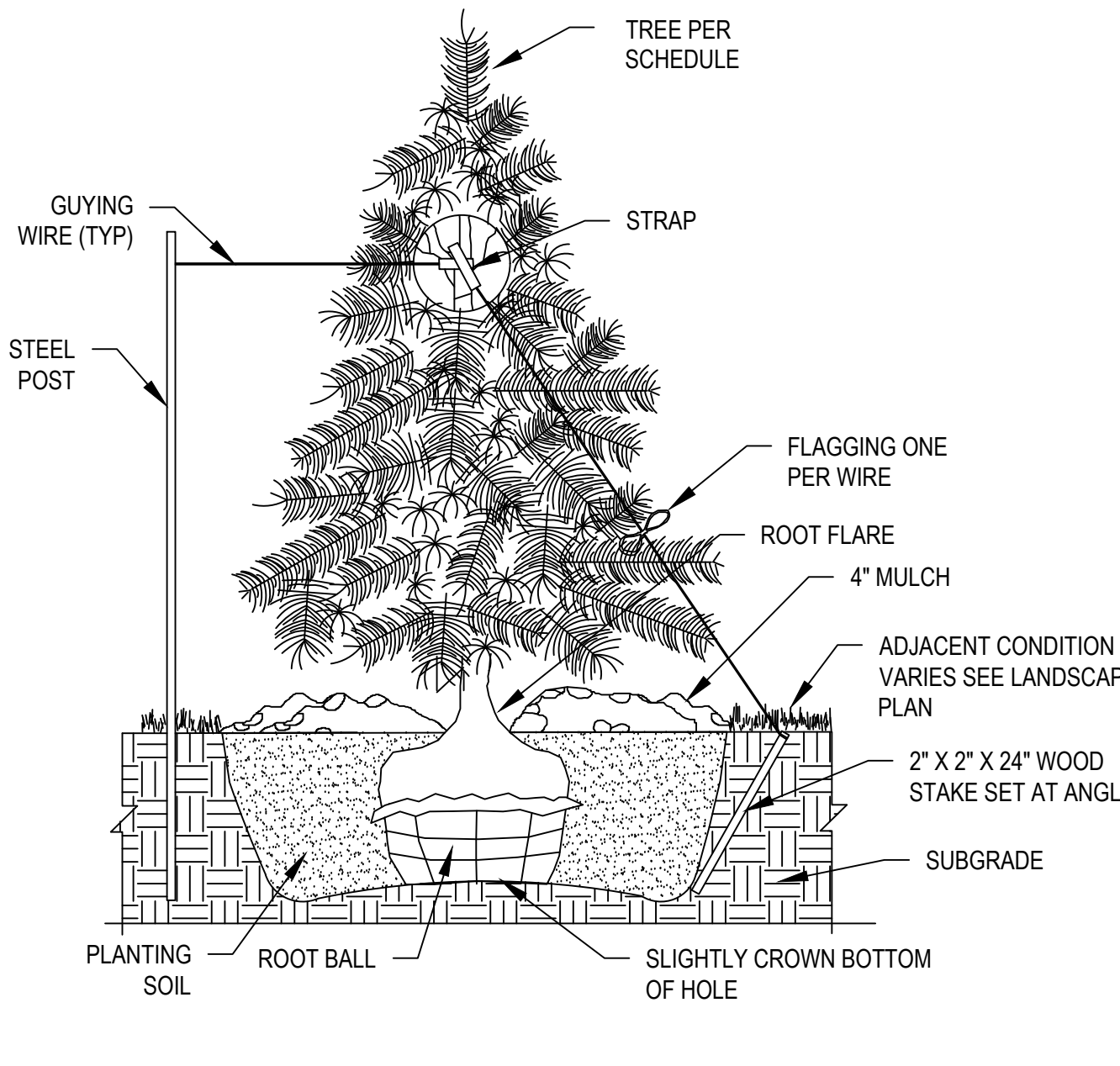

2
L2
EVERGREEN TREE PLANTING DETAIL

- NOTES:
- WIDTH OF PLANTING HOLE: 18" MIN. LARGER THAN ROOT BALL, ON ALL SIDES.
 - DEPTH OF HOLE: ROOT FLARE TO SIT AT OR UP TO 2" ABOVE THE TOP OF THE FINISHED SOIL ELEVATION. LEAVE SOIL UNDISTURBED BENEATH THE ROOT BALL.
 - SCARIFY BOTTOM AND SIDES OF HOLE PRIOR TO PLANTING.
 - SET PLANT ON UNDISTURBED SOIL OR THOROUGHLY COMPACTED PLANTING SOIL.
 - REMOVE TOP 1/3 OF THE BASKET OR THE TOP TWO HORIZONTAL RINGS WHICHEVER IS GREATER. REMOVE ALL BURLAP FROM TOP 1/3 OF ROOT BALL. REMOVE ALL TWINE.
 - REMOVE OR CORRECT STEM GIRDLING ROOTS OR REJECT PLANT.
 - SLIT REMAINING BURLAP AT 6" INTERVALS.
 - PLUMB & BACKFILL WITH PLANTING SOIL AMENDED WITH COMPOST. THOROUGHLY WATER IN TREE WITHIN 2 HOURS TO SETTLE PLANT AND FILL VOIDS.
 - BACKFILL VOIDS AND WATER A SECOND TIME.
 - PLACE SHREDDED HARDWOOD MULCH WITHIN 48 HOURS OF THE SECOND WATERING. NO MULCH TO BE IN CONTACT W/ TRUNK OR BRANCHES.
 - TWO ALTERNATE METHODS OF STAKING TREES ARE ILLUSTRATED IN DETAIL.
 - CONTRACTOR IS RESPONSIBLE FOR MAINTAINING TREES IN A PLUMB POSITION THROUGHOUT THE GUARANTEE PERIOD. IF NEEDED, STAKE TREES USING 16" X 1.5" POLYPROPYLENE OR POLYETHYLENE STRAPS, ATTACH TO POST, OR STAKE WITH 10 GAUGE WIRE. REMOVE WITHIN ONE YEAR.
 - REFER TO PLAN AND SPECS. FOR ADDITIONAL INFORMATION.

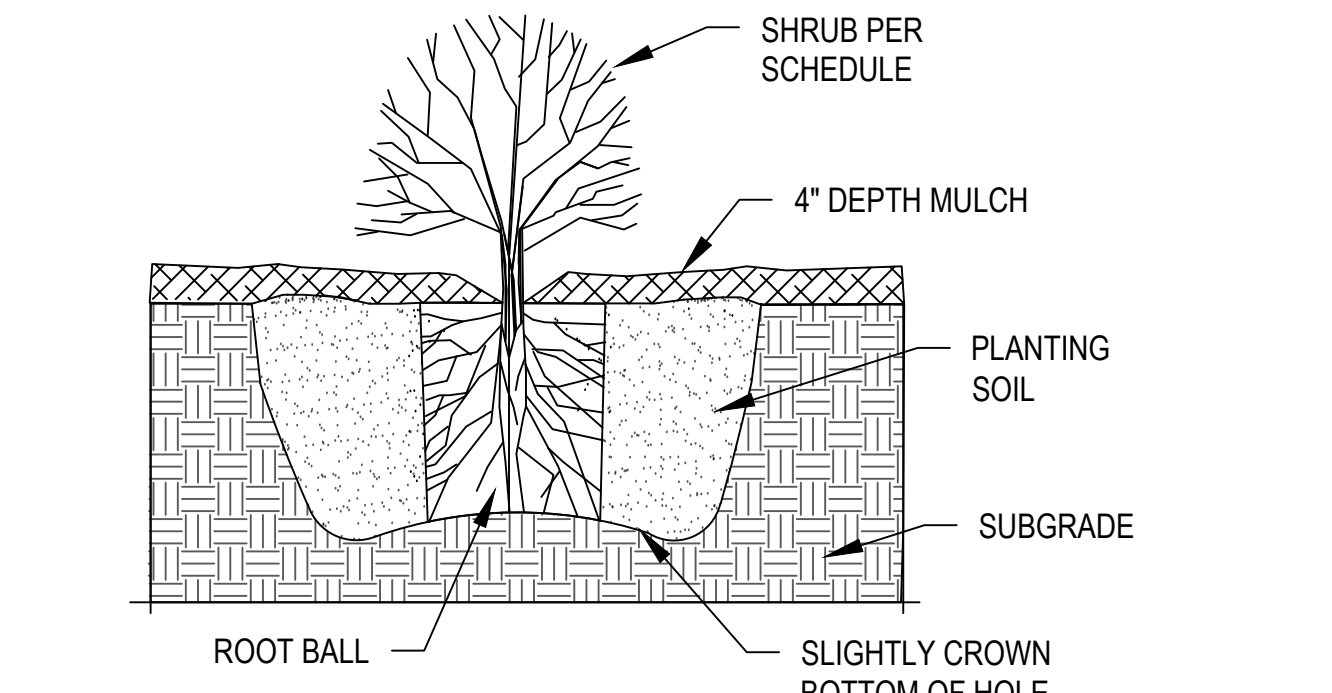

3
L2
SHRUB PLANTING DETAIL

- NOTES:
- PLANT INTO PREPARED PLANTING BED. REMOVE WEEDS, LOOSEN COMPACTED SOILS TO A DEPTH OF 6", AND AMEND PLANTING SOIL WITH COMPOST.
 - PLANT AT SAME DEPTH AS IN CONTAINER.
 - PLACE SHREDDED HARDWOOD MULCH OVER PERENNIAL BED. DO NOT PLACE ANY MULCH ON VEGETATION.
 - THOROUGHLY WATER IN PLANTS.
 - REFER TO PLAN AND SPECS. FOR ADDITIONAL INFORMATION.

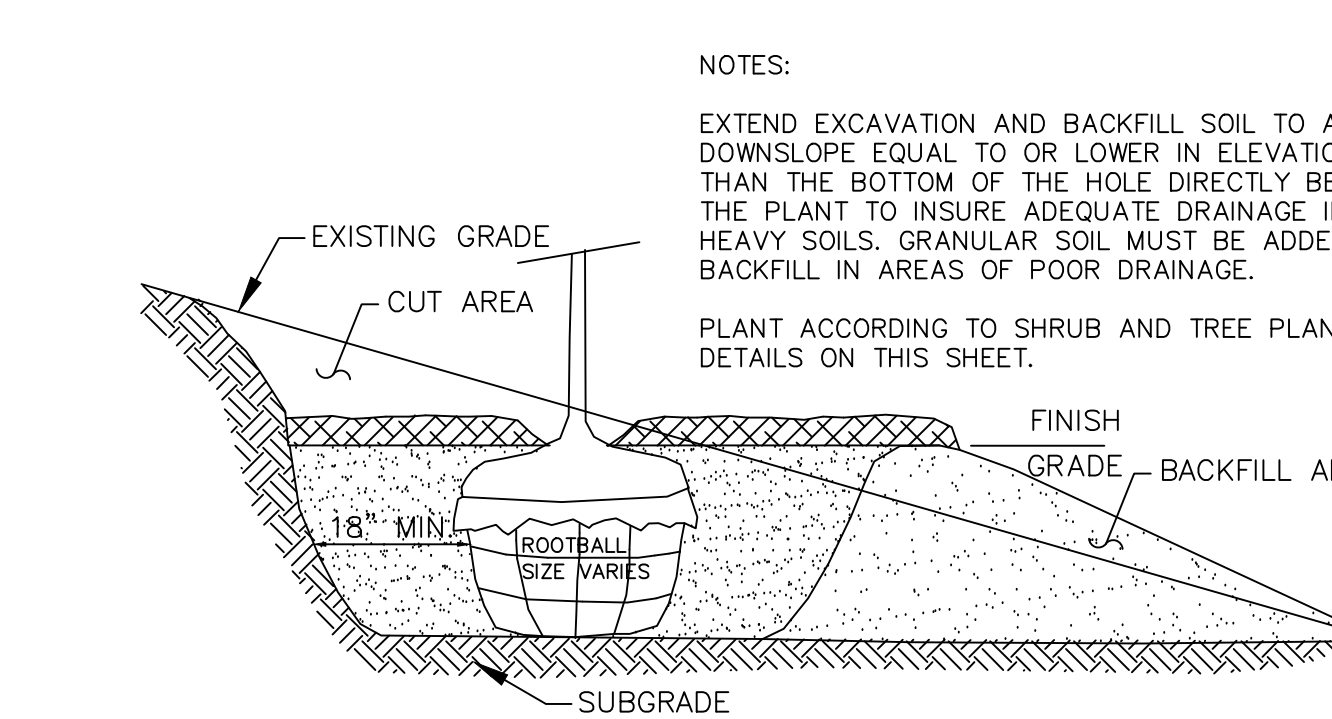

4
L2
PERENNIAL PLANTING DETAIL

- NOTES:
- DIG SHRUB HOLE 12" MIN. LARGER THAN CONTAINER SIZE, ALL SIDES.
 - SCARIFY BOTTOM AND SIDES OF HOLE PRIOR TO PLANTING.
 - REMOVE DEAD OR DAMAGED BRANCHES. RETAIN THE NATURAL FORM OF THE SHRUB.
 - HAND LOOSEN ROOTS OF CONTAINERIZED MATERIAL. SCORE OUTSIDE OF SOIL MASS TO REDIRECT CIRCLING FIBROUS ROOTS.
 - SET SHRUB ON UNDISTURBED SOIL OR ON THOROUGHLY COMPACTED PLANTING SOIL. INSTALL PLANT SO THE TOP OF ROOT FLARE IS AT OR UP TO 2" ABOVE THE FINISHED GRADE.
 - PLUMB AND BACKFILL WITH PLANTING SOIL AMENDED WITH COMPOST. THOROUGHLY WATER IN SHRUB PRIOR TO PLACING MULCH.
 - ALL SHRUB PLANTINGS RECEIVE 4" DEPTH MULCH.
 - REFER TO SPECS. FOR ADDITIONAL INFORMATION.



5
L2
PLANTING ON A SLOPE DETAIL

DATE	REVISION
03.13.2024	PLAN REVISIONS PER CITY REVIEW

I hereby certify that this plan, specification, or report was prepared by me or under my direct supervision and that I am a duly Licensed Landscape Architect under the laws of the State of Minnesota. Name: Carmen Simonet
 Signature: *Carmen Simonet*
 License # 24236 Date: 02.08.24

LANDSCAPE ARCHITECT:
 Carmen Simonet Design LLC
 354 Stonebridge Blvd., St. Paul, MN 55105
 (651) 695-0273 carmen@simonetedesign.com
 www.simonetedesign.com

Hakanson Anderson
 Civil Engineers and Land Surveyors
 3601 Thurston Ave., Anoka, Minnesota 55303
 763-427-5860 FAX: 763-427-0520
 www.hakanson-anderson.com

ST. KATHARINE DREXEL

PLANTING DETAILS & LANDSCAPE SPECS.
 CITY OF RAMSEY, MINNESOTA

SHEET
L2
 OF
L2
 SHEETS
 4719.02

ST. KATHARINE DREXEL

CONSTRUCTION PLANS FOR SITE GRADING AND STORM SEWER, SANITARY SEWER, WATERMAIN, PARKING LOT AND MISCELLANEOUS CONSTRUCTION

FOR CHURCH OF ST. KATHARINE DREXEL IN THE CITY OF RAMSEY

GOVERNING SPECIFICATIONS
 THE 2020 EDITION OF THE MINNESOTA DEPARTMENT OF TRANSPORTATION "STANDARD SPECIFICATIONS FOR CONSTRUCTION" SHALL GOVERN FOR STORM SEWER AND PARKING LOT WORK.
 THE 2023 EDITION OF THE CITY ENGINEER'S ASSOCIATION OF MINNESOTA "STANDARD SPECIFICATIONS" SHALL GOVERN FOR SANITARY SEWER AND WATERMAIN WORK.
 ALL FEDERAL, STATE AND LOCAL LAWS, REGULATIONS, AND ORDINANCES SHALL BE COMPLIED WITH IN THE CONSTRUCTION OF THIS PROJECT.
 ALL TRAFFIC CONTROL DEVICES AND SIGNING SHALL CONFORM TO THE LATEST EDITION OF THE MINNESOTA MANUAL ON UNIFORM TRAFFIC CONTROL DEVICES, INCLUDING THE LATEST FIELD MANUAL FOR TEMPORARY TRAFFIC CONTROL ZONE LAYOUTS.

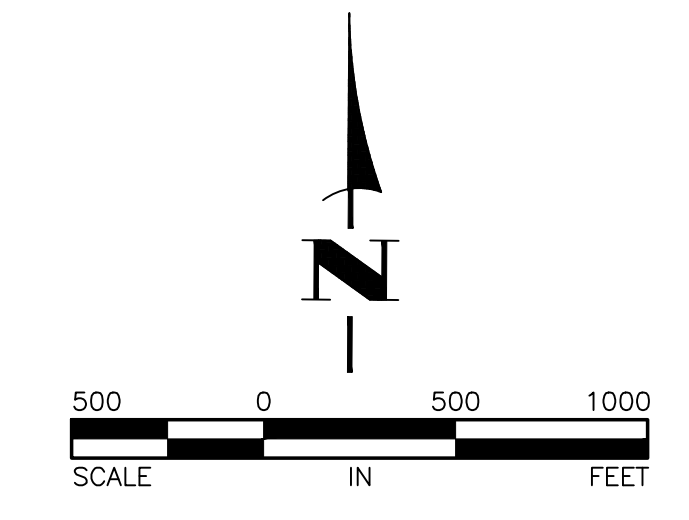
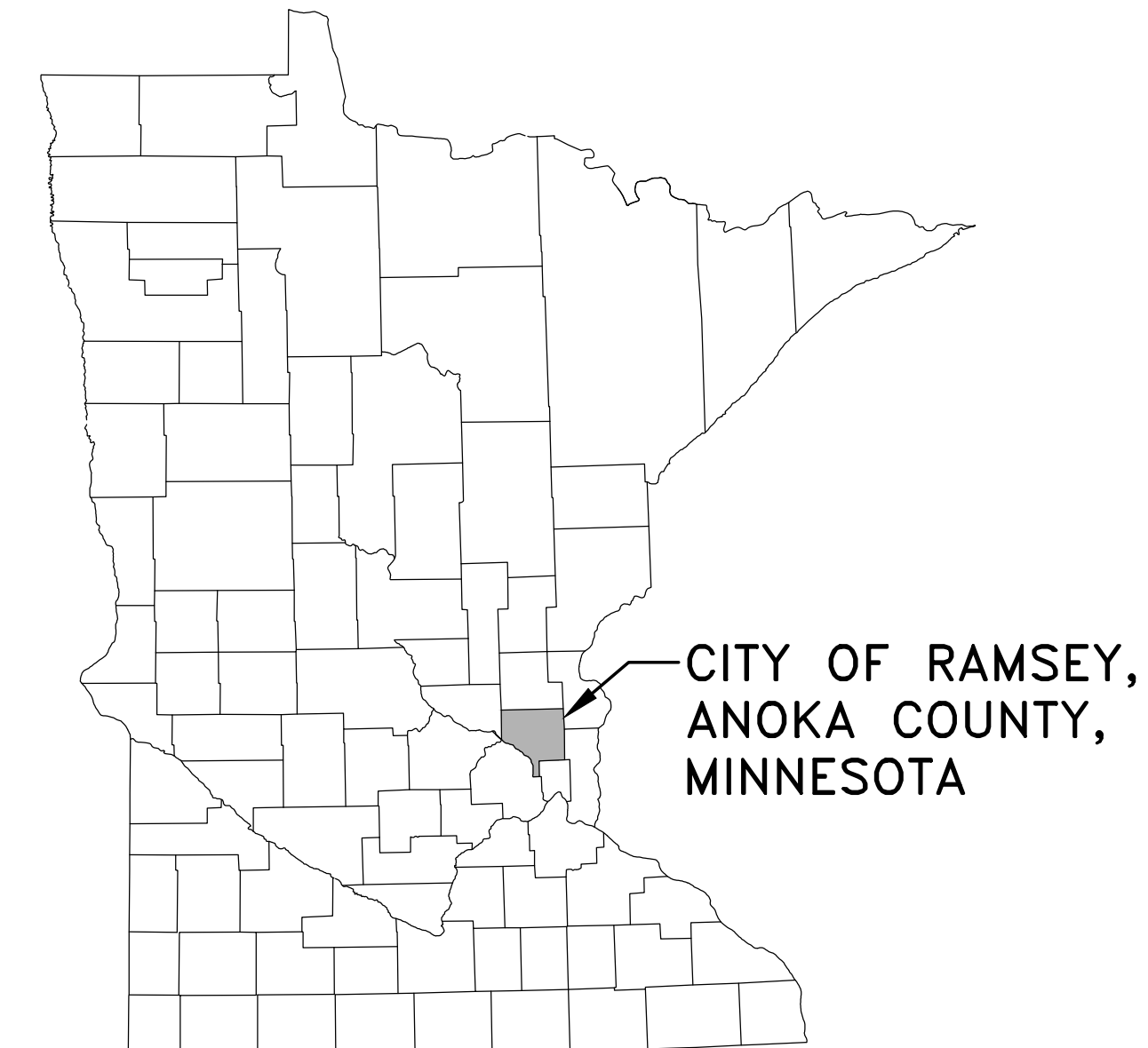
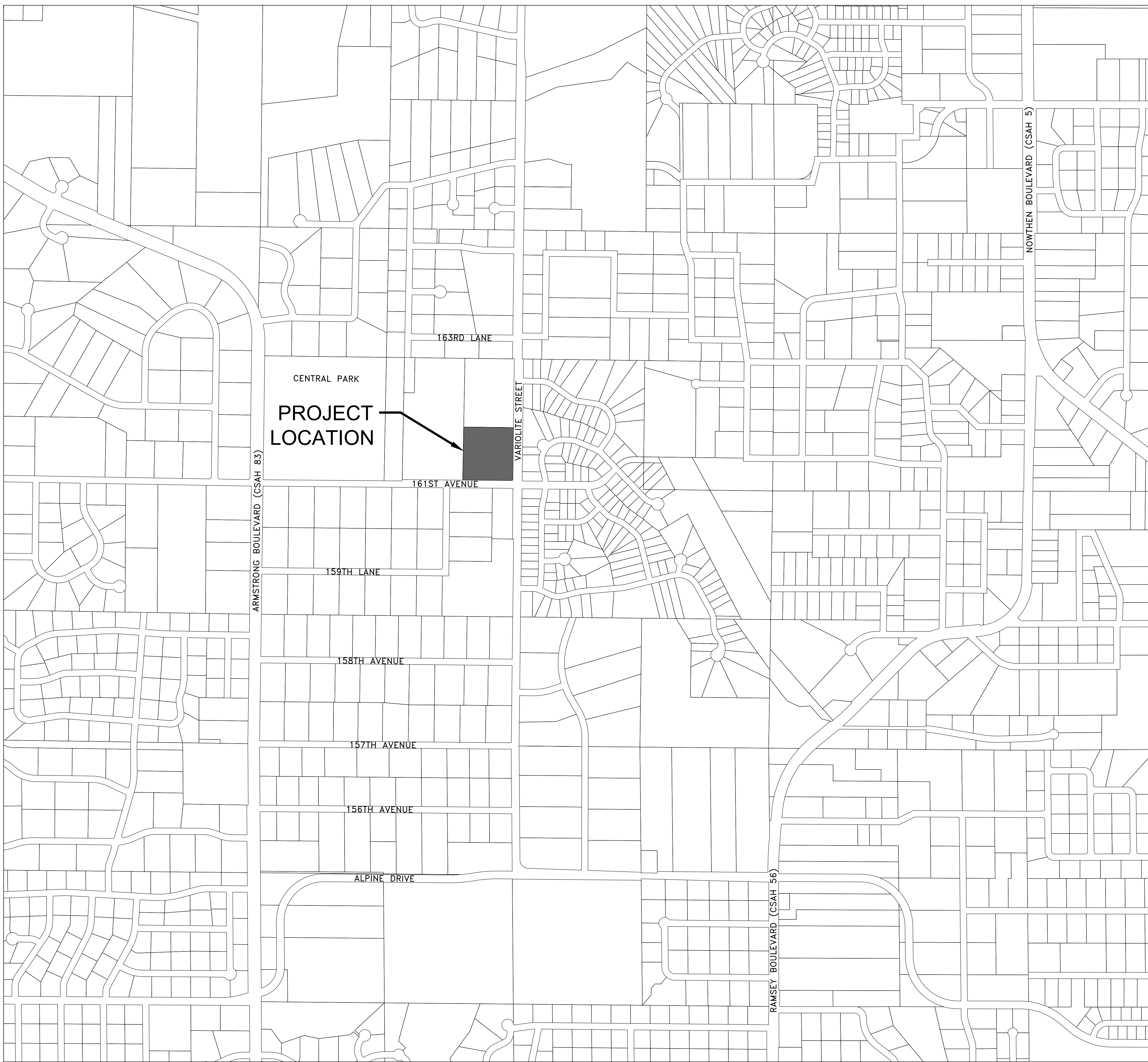

SHEET INDEX
THIS PLAN CONTAINS 15 SHEETS

SHEET NO.	DESCRIPTION
C1	TITLE SHEET
C2	CONSTRUCTION NOTES AND DETAILS
C3	DETAILS
C4-C6	CITY STANDARD PLATES
C7	TREE INVENTORY AND SUMMARY
C8	EXISTING TOPOGRAPHY AND REMOVALS PLAN
C9	SITE PLAN
C10	GRADING, DRAINAGE AND SEDIMENT CONTROL PLAN
C11	STAKING PLAN
C12	UTILITY PLAN
C13	RESTORATION AND PAVING PLAN
L1	LANDSCAPE PLAN
L2	PLANTING DETAILS & LANDSCAPE SPECS.

I hereby certify that this plan, specification, or report was prepared by me or under my direct supervision and that I am a duly Licensed Professional Engineer under the laws of the State of Minnesota.

Tim Eggerichs
 TIMOTHY A. EGGERICHS, P.E.
 HAKANSON ANDERSON
 DESIGN ENGINEER

43362 DATE 2/12/24
 LIC. NO.

DATE	REVISION
3/19/24	PLAN REVISIONS PER LRRWMO REVIEW

THE SUBSURFACE UTILITY INFORMATION IN THIS PLAN IS UTILITY QUALITY LEVEL D. THIS QUALITY LEVEL WAS DETERMINED ACCORDING TO THE GUIDELINES OF C1/ASCE 38-02, ENTITLED "STANDARD GUIDELINES FOR THE COLLECTION AND DEPICTION OF EXISTING SUBSURFACE UTILITY DATA."

- BENCHMARKS:**
- TOP NUT OF THE HYDRANT LOCATED IN THE NORTHWEST CORNER OF 161ST AVENUE AND VARIOLITE STREET.
ELEVATION=902.92 (NAVD 88)
 - TOP NUT OF THE HYDRANT LOCATED ON THE WEST SIDE OF VARIOLITE STREET, APPROXIMATELY 1100 FEET NORTH OF 161ST AVENUE.
ELEVATION=875.68 (NAVD 88)

GENERAL CONSTRUCTION AND SOILS NOTES:

- STRIP ALL INPLACE TOPSOIL IN AREAS TO BE DISTURBED BY CONSTRUCTION AND REUSE AS SLOPE DRESSING. IN AREAS OF PARKING LOT AND BUILDING CONSTRUCTION, THE EXPOSED SAND SHALL BE SURFACE COMPACTED TO AT LEAST 100% OF THE STANDARD PROCTOR MAXIMUM DRY DENSITY, ASTM D698, IN AT LEAST THE UPPER 3 FEET.
- UNLESS OTHERWISE RECOMMENDED IN THESE PLANS, THE GRADING SUBGRADE SHALL BE CONSTRUCTED OF SUITABLE GRADING MATERIAL. THE FILL SHALL BE PLACED IN 8" TO 10" LOOSE LIFTS, AND COMPACTED TO 100% OF THE STANDARD PROCTOR MAXIMUM DRY DENSITY.
- SUITABLE GRADING MATERIAL FOR THIS PROJECT SHALL CONSIST OF ALL SOILS ENCOUNTERED WITH THE EXCEPTION OF TOPSOIL, SILT, DEBRIS, ORGANIC MATERIAL AND OTHER UNSTABLE MATERIAL.
- CONTRACTOR SHALL REVIEW THE AVAILABLE GEOTECHNICAL EXPLORATION REPORTS FOR ADDITIONAL SITE PREPARATION REQUIREMENTS.
- PROVIDE A SAW CUT WHEN PLACING NEW PAVEMENT ADJACENT TO INPLACE PAVEMENT AND AT TERMINI OF CONSTRUCTION TO ENSURE A UNIFORM JOINT.
- BITUMINOUS AND CONCRETE ITEMS DISTURBED BY CONSTRUCTION SHALL BECOME THE PROPERTY OF THE CONTRACTOR AND SHALL BE DISPOSED OF IN ACCORDANCE WITH MN/DOT SPEC. 2104.
- USE TACK COAT BETWEEN ALL BITUMINOUS MIXTURES. THE BITUMINOUS TACK COAT MATERIAL SHALL BE APPLIED AT A UNIFORM RATE OF 0.04 GAL/SY TO 0.06 GAL/SY BETWEEN BITUMINOUS LAYERS. THE APPLICATION RATES ARE FOR UNDILUTED EMULSIONS.
- THE BITUMINOUS MIXTURES SHALL MEET THE REQUIREMENTS OF SPECIFICATIONS 2360 AND 3139.

GENERAL EROSION CONTROL NOTES:

- EROSION CONTROL SHALL CONFORM TO THE MN/DOT EROSION CONTROL HANDBOOK.
- PRIOR TO ANY CONSTRUCTION ACTIVITIES, THE CONTRACTOR SHALL ACQUIRE THE MPCA NPDES CONSTRUCTION STORMWATER GENERAL PERMIT. A COPY OF THE PERMIT SHALL BE SUBMITTED TO THE CITY PRIOR TO THE PRECONSTRUCTION MEETING.
- THE CONTRACTOR SHALL INSTALL EROSION AND SEDIMENT CONTROL FACILITIES (BMP'S) PRIOR TO GRADING AND REMOVAL ACTIVITIES. BMP'S SHALL BE MAINTAINED FOR THE DURATION OF CONSTRUCTION ACTIVITIES AND POTENTIAL FOR EROSION HAS PASSED.
- THE CONTRACTOR SHALL SCHEDULE HIS OPERATION TO MINIMIZE THE AMOUNT OF DISTURBED AREA AT ANY GIVEN TIME.
- BMP'S SHALL BE INSPECTED DAILY BY THE CONTRACTOR. OBSERVATIONS SHALL BE RECORDED IN AN INSPECTION LOG. WEEKLY INSPECTION LOGS AND INSPECTION LOGS AFTER EVERY 1/2" RAIN EVENT SHALL BE SUBMITTED TO THE CITY INSPECTOR.
- ALL EROSION AND SEDIMENT CONTROL MEASURES SHALL BE PROPERLY DISPOSED OF WITHIN THIRTY (30) DAYS AFTER FINAL SITE STABILIZATION.
- THE CONTRACTOR SHALL FILE A NOTICE OF TERMINATION WITH THE MPCA AFTER FINAL STABILIZATION HAS BEEN APPROVED. THE CITY SHALL REVIEW AND APPROVE THE NOTICE OF TERMINATION PRIOR TO SUBMITTAL TO THE MPCA.

REFERENCE NOTES:

- SEE CITY PLATE NO. STR-26 FOR MODIFIED CLASS 5 AGGREGATE BASE SPECIFICATIONS.
- CONTRACTOR SHALL PROTECT THE INFILTRATION BASIN WITH 48" HIGH ORANGE SAFETY FENCE PRIOR TO THE START OF CONSTRUCTION.
- CONSTRUCTION EQUIPMENT SHALL BE MINIMIZED OVER THE FOOTPRINT OF THE BASIN. ONLY LOW PRESSURE, WIDE TRACKED EQUIPMENT SHALL BE USED FOR CONSTRUCTION.
- INFILTRATION BASIN SHALL NOT BE GRADED TO WITHIN THREE FEET OF THE FINAL GRADE UNTIL THE CONTRIBUTING DRAINAGE AREA HAS BEEN CONSTRUCTED AND FULLY STABILIZED OR RIGOROUS EROSION PREVENTION AND SEDIMENT CONTROLS TO KEEP SEDIMENT AND RUNOFF COMPLETELY AWAY FROM THE INFILTRATION BASIN HAS BEEN PROVIDED.
- THE INFILTRATION RATE FOR THE SOILS IN THE BOTTOM OF THE INFILTRATION BASIN SHALL BE BETWEEN 0.60 AND 8.3 INCHES PER HOUR. THE CONTRACTOR MAY HAVE TO AMEND THE SOILS TO MEET THIS REQUIREMENT.
- COMPACTED SOIL WITHIN THE INFILTRATION BASIN SHALL BE SCARIFIED TO A DEPTH OF 12" PRIOR TO RESTORATION.
- BITUMINOUS AND CONCRETE SECTIONS SHALL BE VERIFIED BY A GEOTECHNICAL ENGINEER.

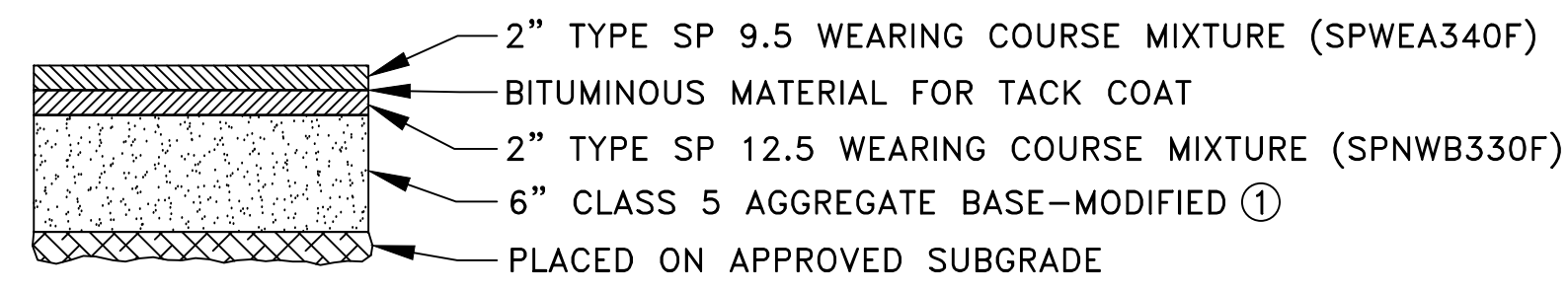

1 LIGHT DUTY BITUMINOUS PAVEMENT SECTION
NO SCALE

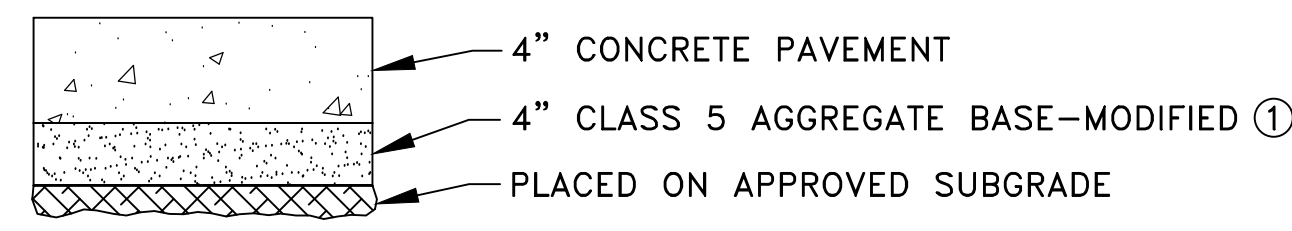

2 CONCRETE WALK/PAVEMENT SECTION
NO SCALE

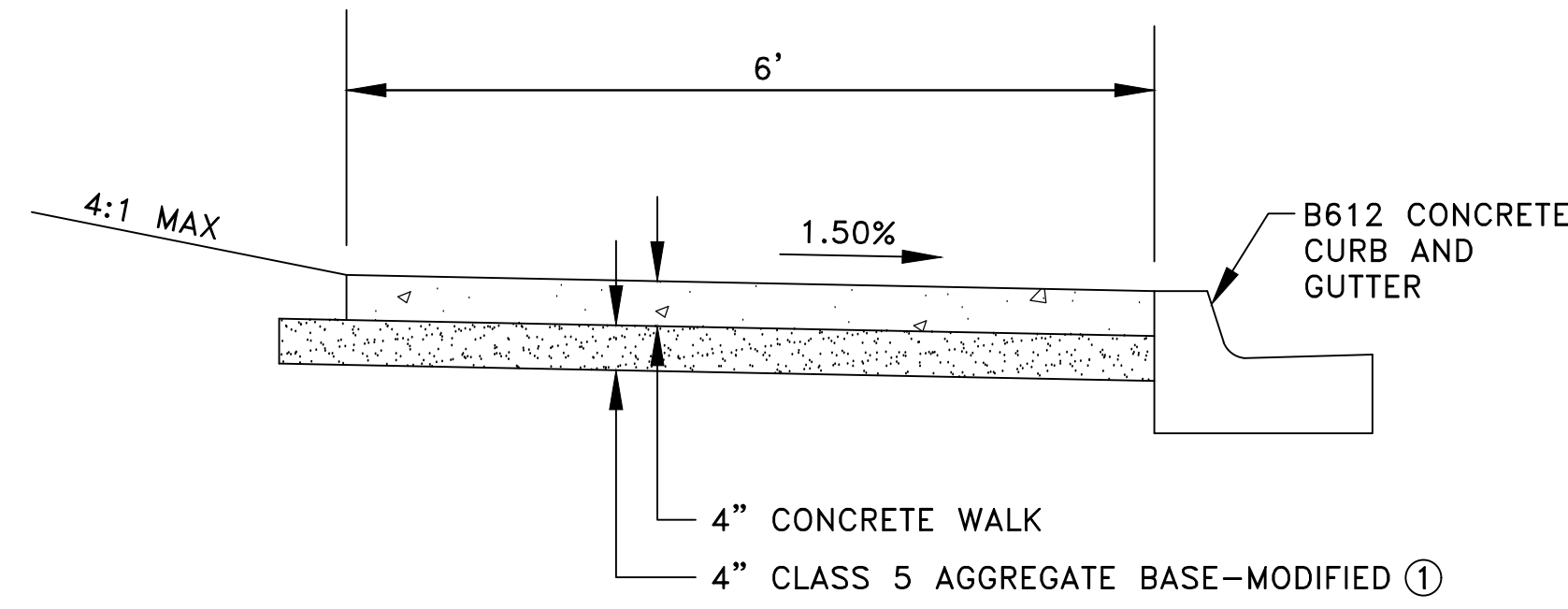

3 CONCRETE SIDEWALK
NO SCALE

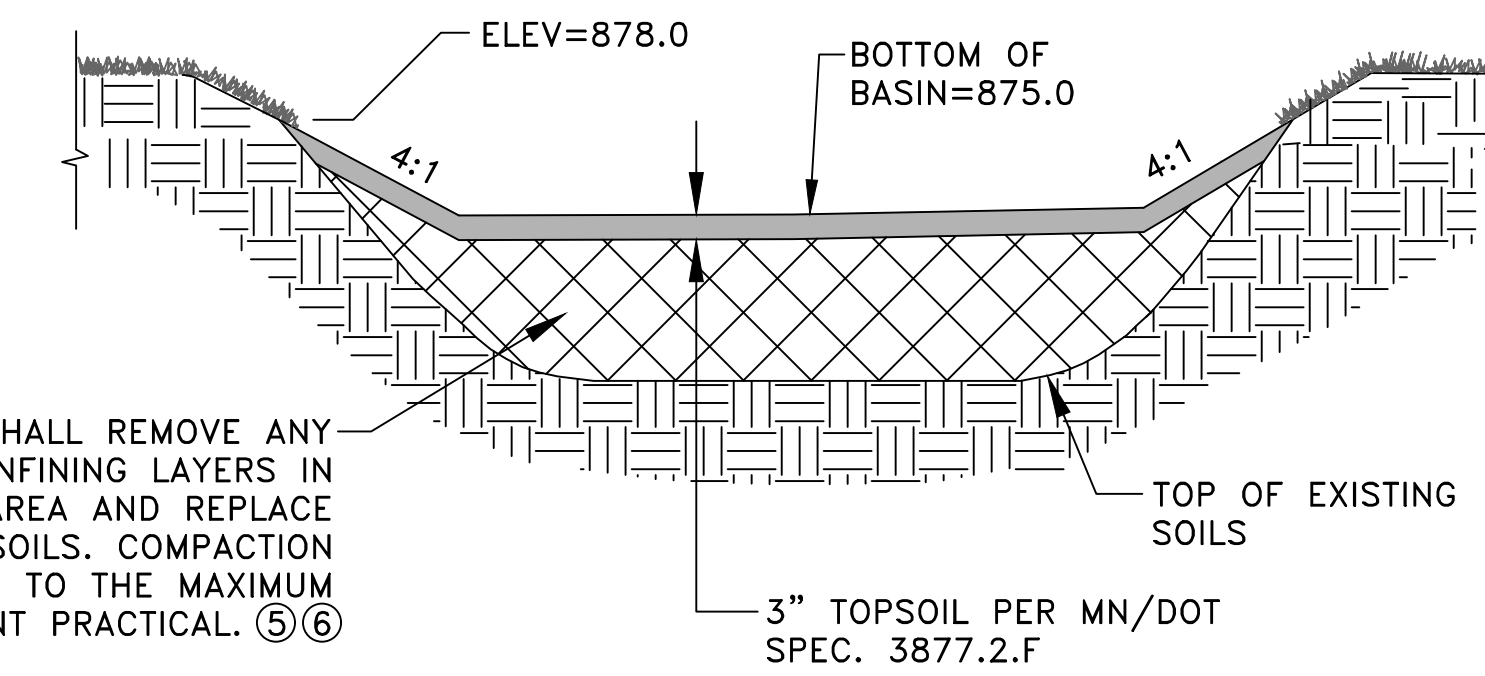

4 INFILTRATION BASIN
NO SCALE

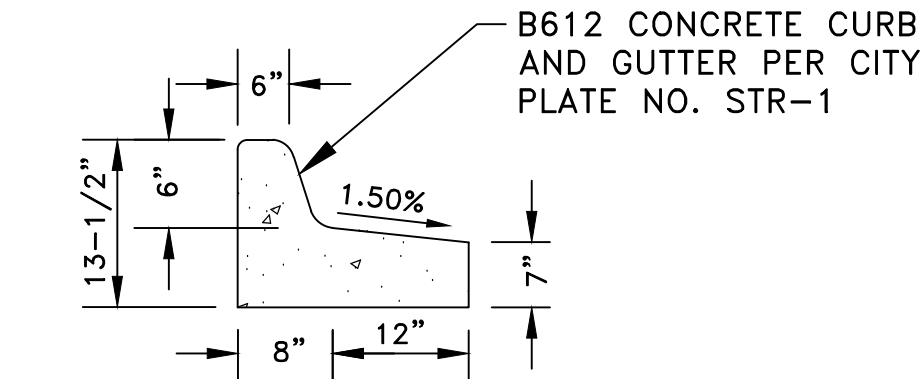

5 TIPOUT CURB DETAIL
NO SCALE

DATE	REVISION	DATE	REVISION
3/19/20	PLAN REVISIONS PER CLIENT REVIEW		

I hereby certify that this plan, specification, or report was prepared by me or under my direct supervision and that I am a duly Licensed Professional Engineer under the laws of the State of Minnesota.

 TIMOTHY A. EDSERSACHS, P.E.
 Date 2/12/24 Lic. No. 43362

DESIGNED BY: TAE
 DRAWN BY: TAE
 CHECKED BY: CJJ

Hakanson Anderson
 Civil Engineers and Land Surveyors
 3601 Thurston Ave., Anoka, Minnesota 55303
 763-427-5860 FAX 763-427-0520
 www.hakanson-anderson.com

ST. KATHARINE DREXEL

CONSTRUCTION NOTES AND DETAILS
 CITY OF RAMSEY, MINNESOTA

SHEET C2 OF C13 SHEETS
 4719.02

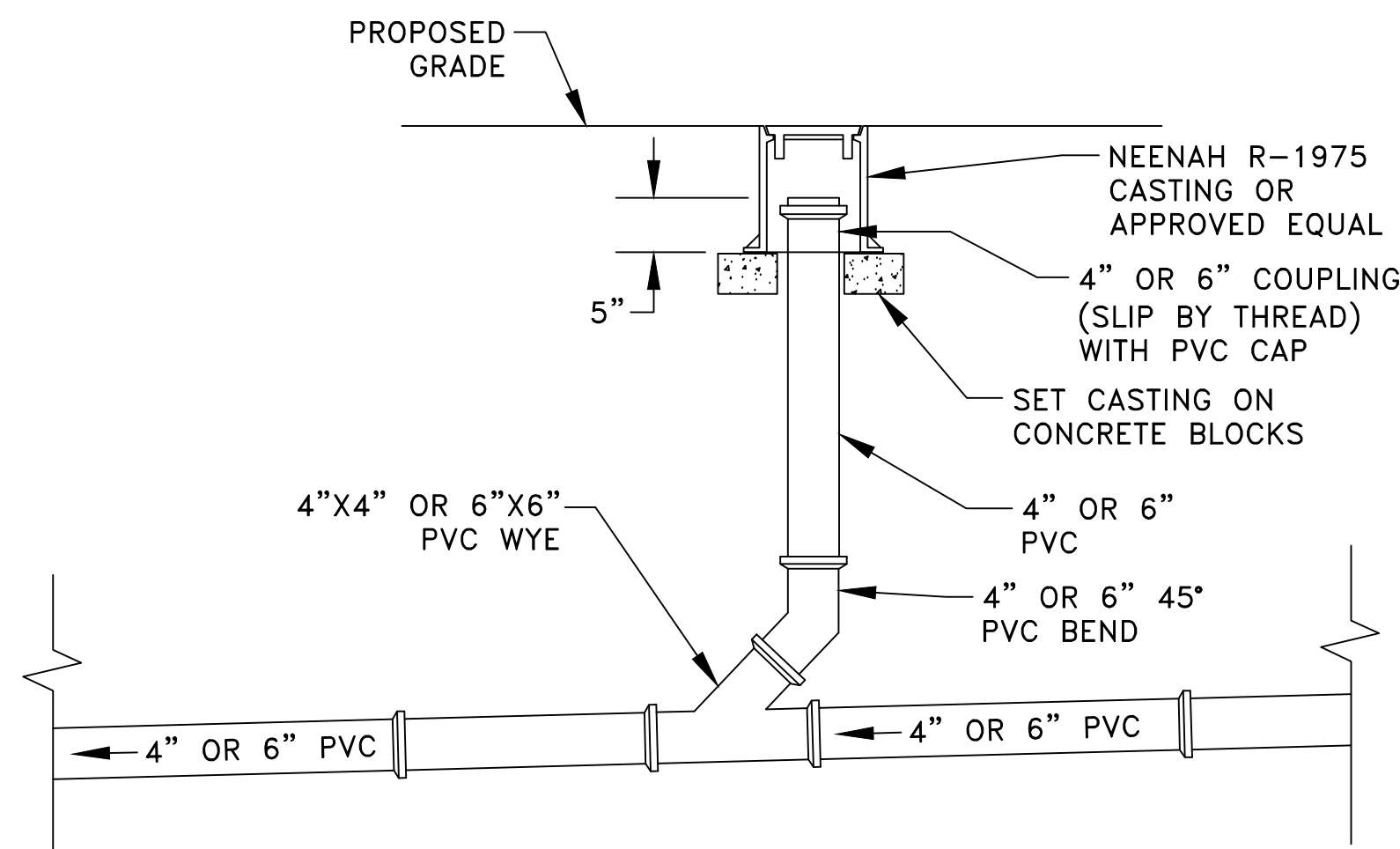

1 SANITARY SEWER CLEANOUT
NO SCALE
C3

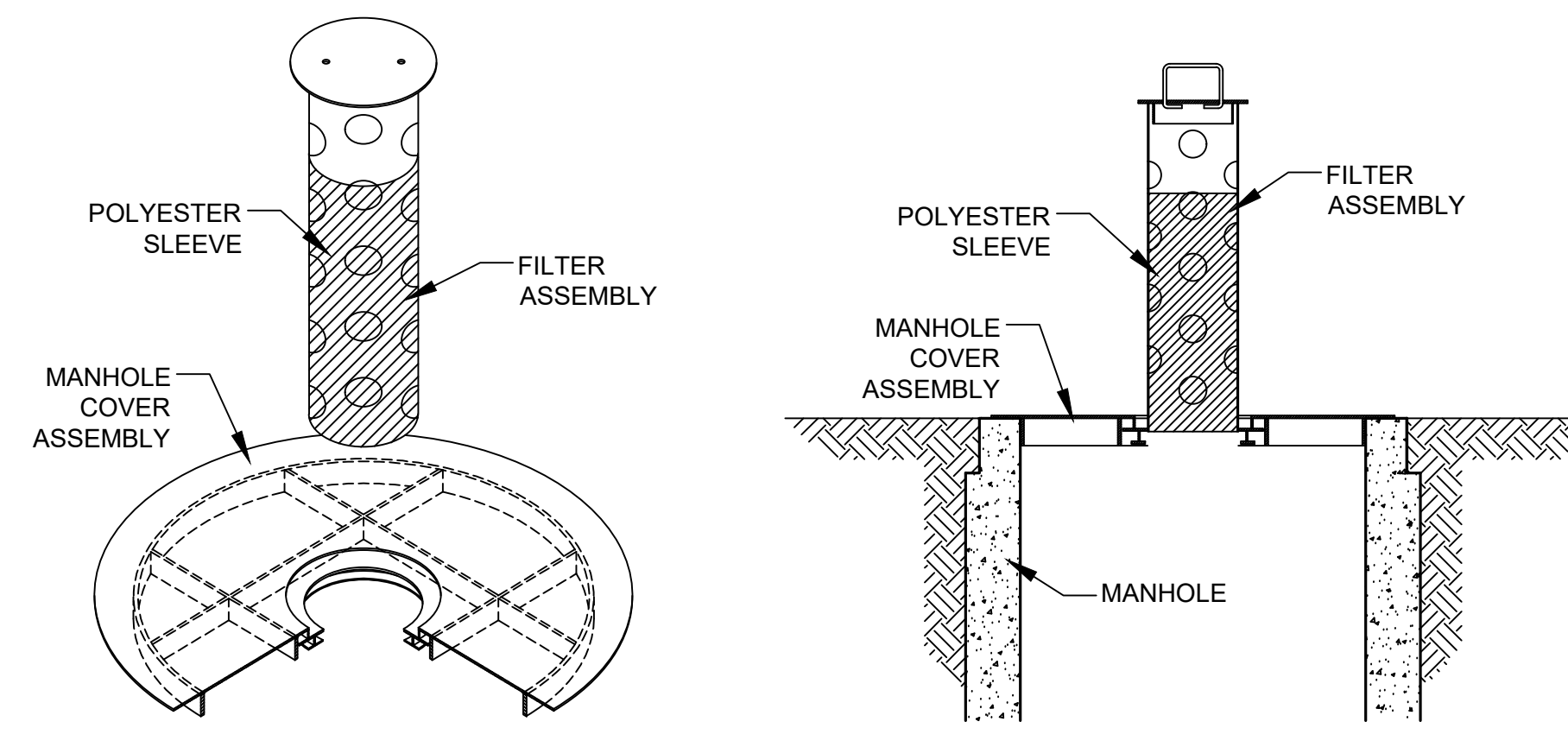

ISOMETRIC VIEW

IN-PLACE ELEVATION VIEW

2 STORM DRAIN INLET PROTECTION ①
C3

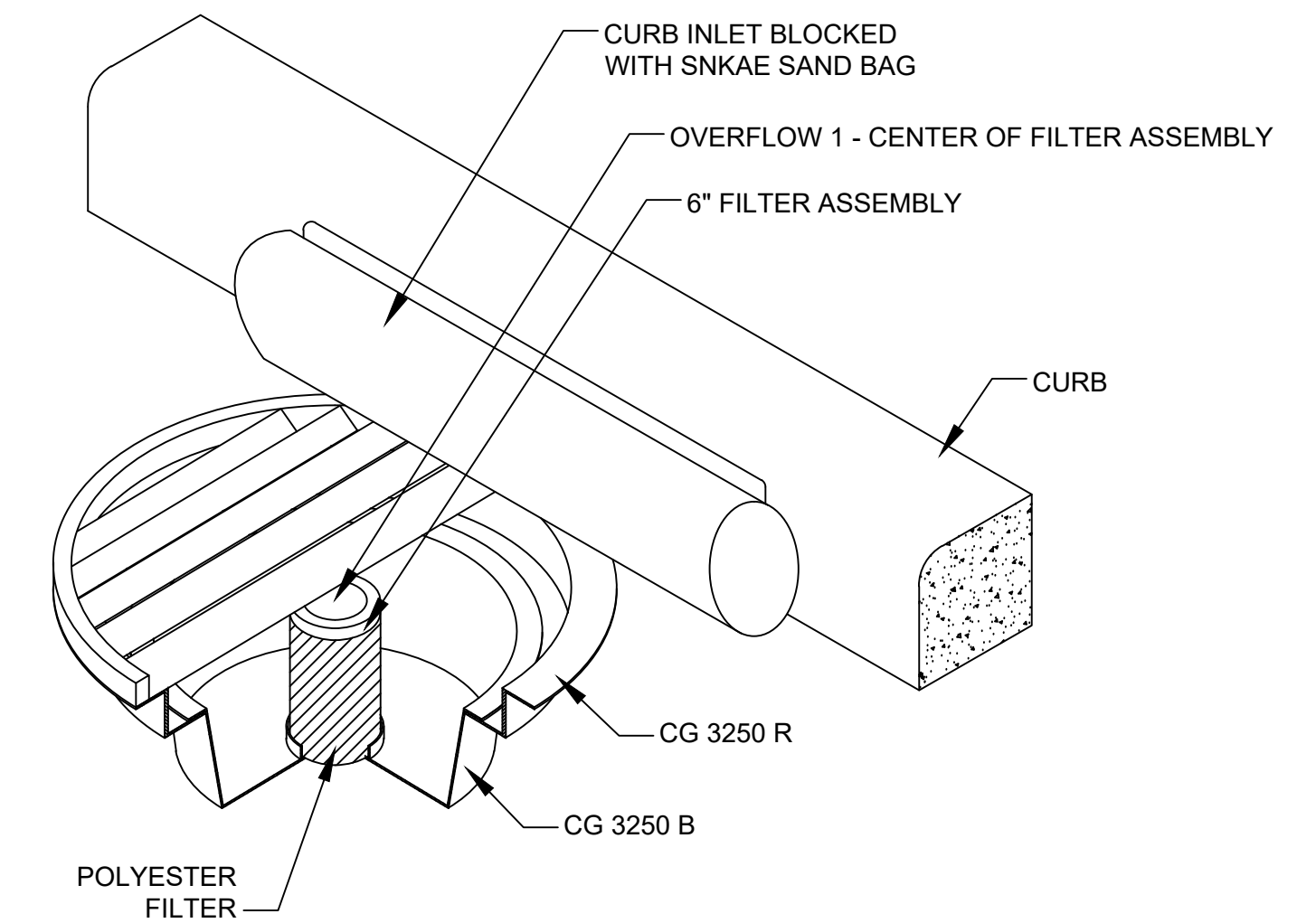

3 STORM DRAIN INLET PROTECTION ①
C3

REFERENCE NOTES:
① INLET PROTECTION SHALL BE INSTALLED ON ALL CASTINGS RECEIVING RUNOFF FROM THE PROJECT AREA. INLET PROTECTION SHALL BE INSTALLED ON EXISTING, OFF SITE CASTINGS PRIOR TO THE START OF CONSTRUCTION. WIMCO MODELS CG 3250 R AND RD 27 ARE SHOWN.

K:\PROJECTS\1919\191902\ENGINEERING\PLAN\DWG\191902_DETAILS.dwg

DATE	REVISION	DATE	REVISION
3/13/21	PLAN REVISIONS PER CITY REVIEW		
3/19/20	PLAN REVISIONS PER CLIENT REVIEW		

I hereby certify that this plan, specification, or report was prepared by me or under my direct supervision and that I am a duly Licensed Professional Engineer under the laws of the State of Minnesota.

Timothy A. Ebersbach
TIMOTHY A. EBERSBACH, P.E.
Date 2/12/24 Lic. No. 43362

DESIGNED BY: TAE
DRAWN BY: TAE
CHECKED BY: CJJ

Hakanson Anderson
Civil Engineers and Land Surveyors
3601 Thurston Ave., Anoka, Minnesota 55303
763-427-5860 FAX 763-427-0520
www.hakanson-anderson.com

ST. KATHARINE DREXEL

DETAILS
CITY OF RAMSEY, MINNESOTA

SHEET
C3
OF
C13
SHEETS
4719.02

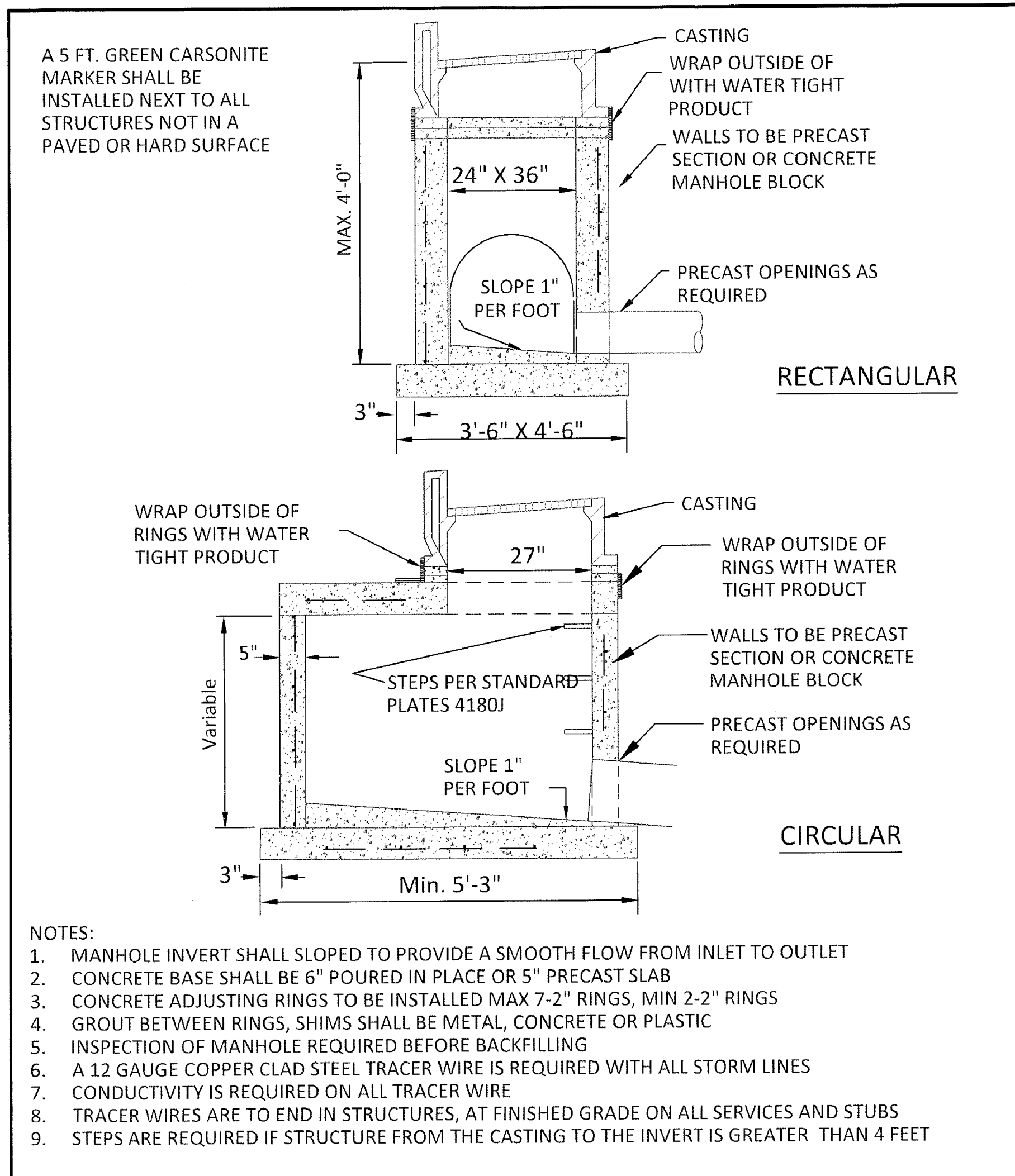

APPROVED: 1 - 2024

City of RAMSEY
CITY PLATE No. STO-1

STANDARD DETAILS: CATCH BASIN

R-2560 Series
Beehive Grates with Frames

SUITABLE FOR DRAINAGE ON CIRCUMSTANCES WHERE CLOGGING OF A FLAT GRATING IS A PROBLEM. EXCELLENT FOR ROADSIDE OR EARTH DITCH CATCH BASINS.

Catalog No.	Dimensions in Inches							WL LBS	
	A	B	C	D	E	F	G		
R-2560-A	12	1	11	12 1/2	16	4	4	80	
R-2560-B	15	1/2	11 1/4	15	15	5	3	120	
R-2560-C	18	1	11 1/4	16 1/2	20 1/2	8	4	190	
R-2560-C1	22	1 1/2	20	23	28	4	4 1/2	195	
R-2560-C2	22	1 1/2	20 1/2	24	28 1/4	6	4 1/2	270	
R-2560-D	22	1 1/2	20	24 1/2	35	9	4 1/2	315	
R-2560-D1	22	1 1/2	20 1/2	23	28 1/4	4	7	210	
R-2560-D2	22	1 1/2	20	24	35	6	7	285	
R-2560-D3	22	1 1/2	20	24 1/2	36	9	7	345	
R-2560-E	25	3/4	1 1/2	21	25 1/2	35 1/2	9	7	340
R-2560-EA	25	3/4	7/8	24 1/8	28 1/2	35 1/2	4	6	235
R-2560-EB	25	3/4	7/8	24 1/8	28 1/2	35 1/2	4	9	255
R-2560-E1	25	3/4	7/8	24 1/8	28 1/2	35 1/2	7	6	285
R-2560-E2	25	3/4	7/8	24 1/8	28 1/2	35 1/2	7	9	300
R-2560-E5	25	3/4	7/8	24 1/8	28 1/2	35 1/2	8	6	345
R-2560-E8	25	3/4	7/8	24 1/8	28 1/2	35 1/2	8	9	365
R-2560-E7	25	3/4	7/8	24 1/8	28 1/2	35 1/2	9	6	350
R-2560-E9	25	3/4	7/8	24 1/8	28 1/2	35 1/2	9	9	365
R-2560-E9	25	3/4	7/8	24 1/8	28 1/2	35 1/2	10	6	360
R-2560-E10	25	3/4	7/8	24 1/8	28 1/2	35 1/2	10	9	385
R-2560-G	32	1 1/2	30	35	46	7	4	535	

R-2570 Catch Basin Frame, Grate
Light Duty
Total Weight 170 Pounds

APPROVED: 9 - 2011

City of RAMSEY
CITY PLATE No. STO-6

STANDARD DETAILS: STORM CASTING - NON TRAFFIC AREAS

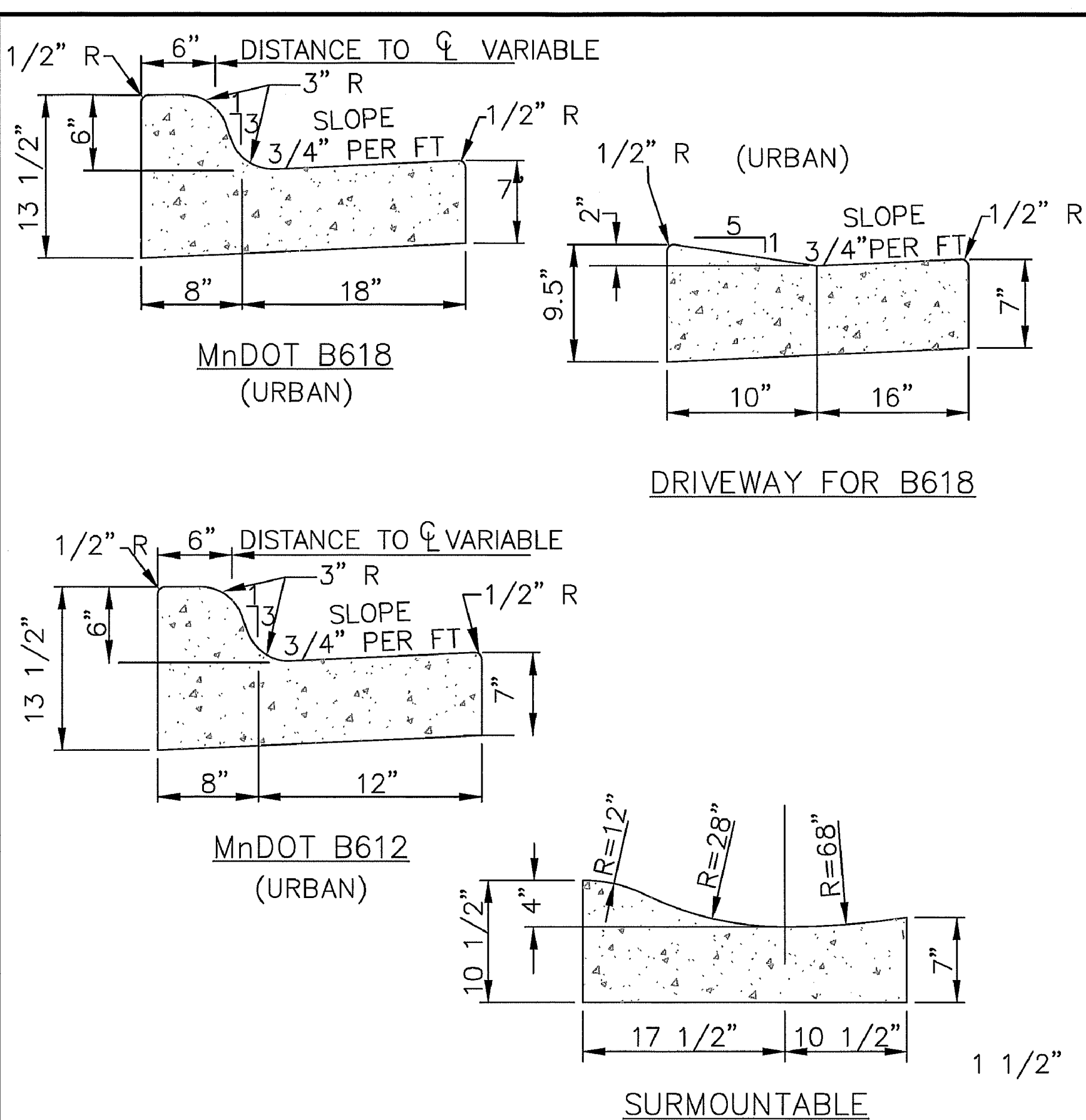
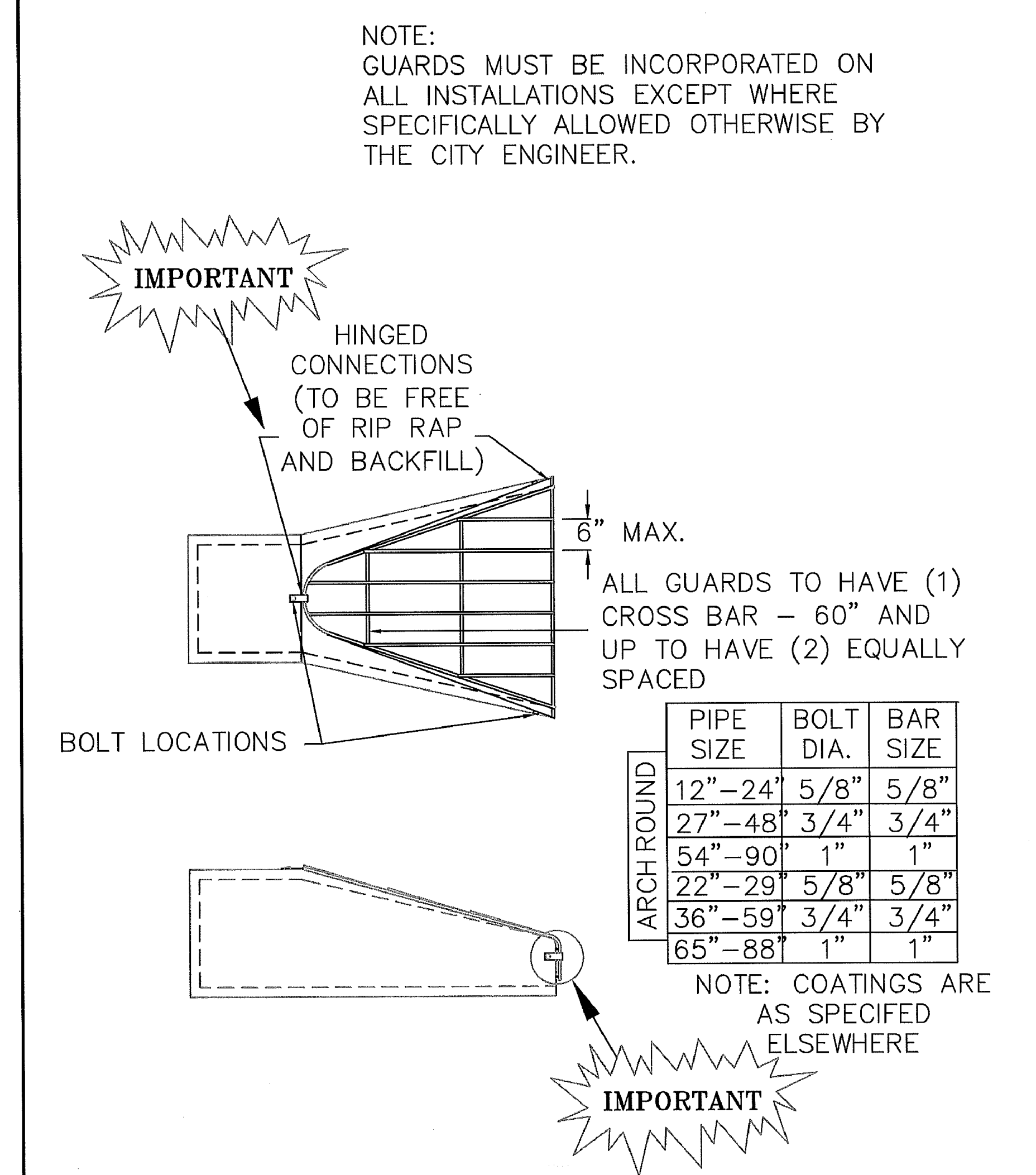

APPROVED: 1 - 2016

City of RAMSEY
CITY PLATE No. STR-1

STANDARD DETAILS: CURB AND GUTTER

TABLE A MODIFIED CLASS 5 SPECIFICATIONS

% PASSING

1"	100
3/4"	90 - 100
3/8"	50 - 80
No.4	35 - 70
No.10	20 - 60
No.40	10 - 35
No.200	5 - 10

APPROVED: 2 - 2003

City of RAMSEY
CITY PLATE No. STR-26

STANDARD DETAILS: MODIFIED CLASS 5 SPECIFICATIONS

DATE	REVISION	DATE	REVISION
3/13/24	PLAN REVISIONS PER CITY REVIEW		

I hereby certify that this plan, specification, or report was prepared by me or under my direct supervision and that I am a duly Licensed Professional Engineer under the laws of the State of Minnesota.

Timothy A. Ebersbach, P.E.
Date 2/12/24 Lic. No. 43362

DESIGNED BY: TAE
DRAWN BY: TAE
CHECKED BY: CJJ

Hakanson Anderson
Civil Engineers and Land Surveyors
3601 Thurston Ave., Anoka, Minnesota 55303
763-427-5860 FAX 763-427-0520
www.hakanson-anderson.com

ST. KATHARINE DREXEL

CITY STANDARD PLATES

CITY OF RAMSEY, MINNESOTA

SHEET C5 OF C13 SHEETS

4719.02

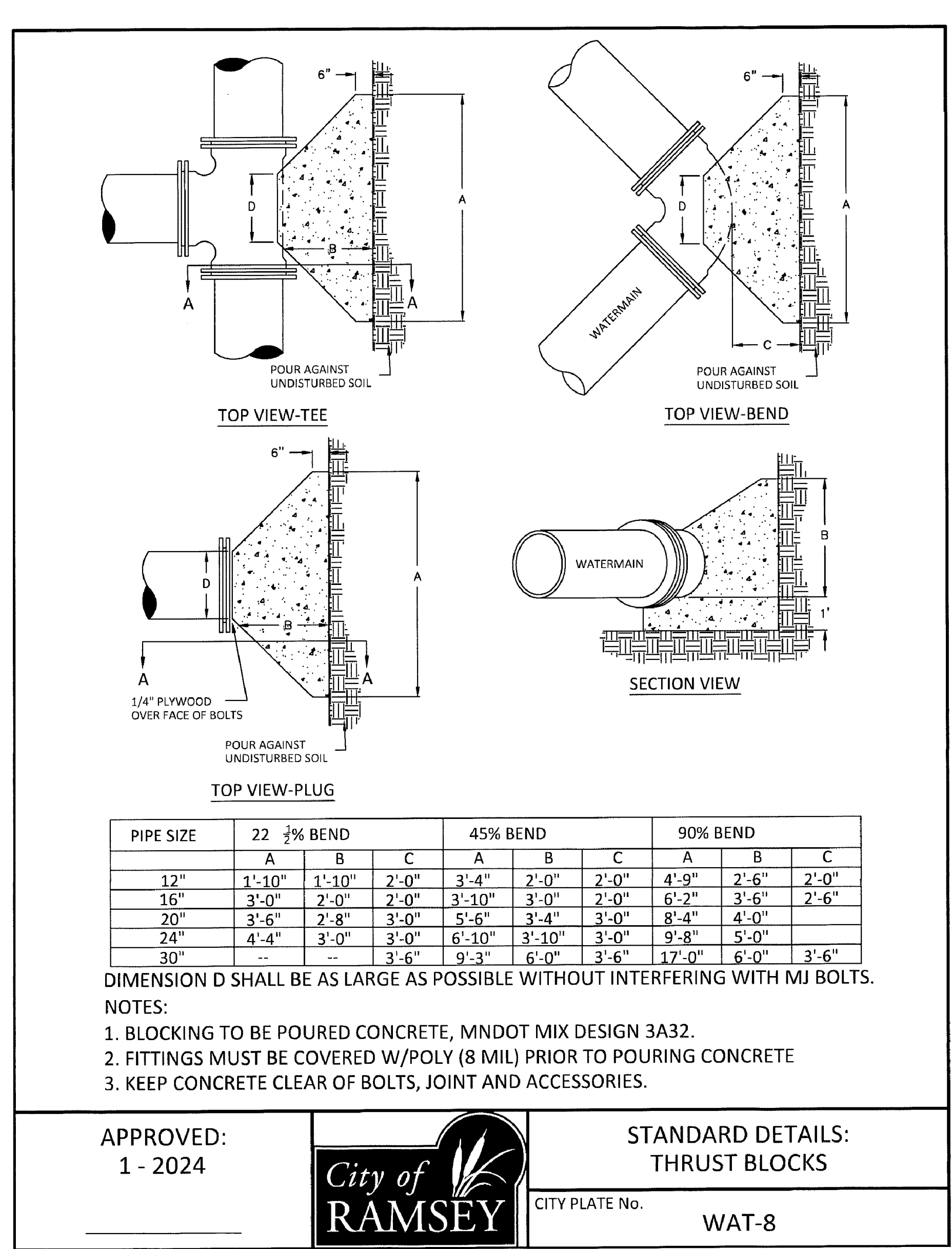
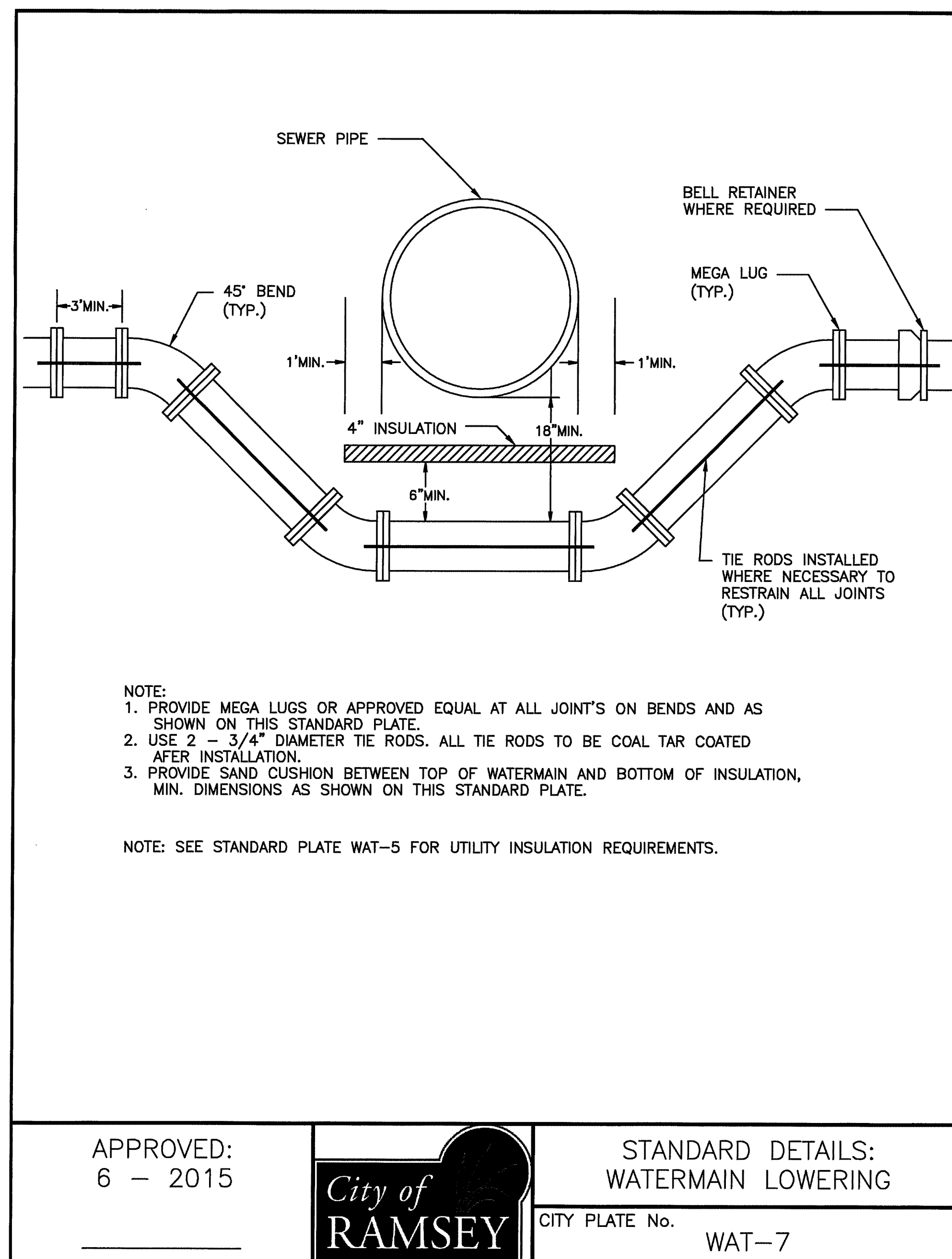
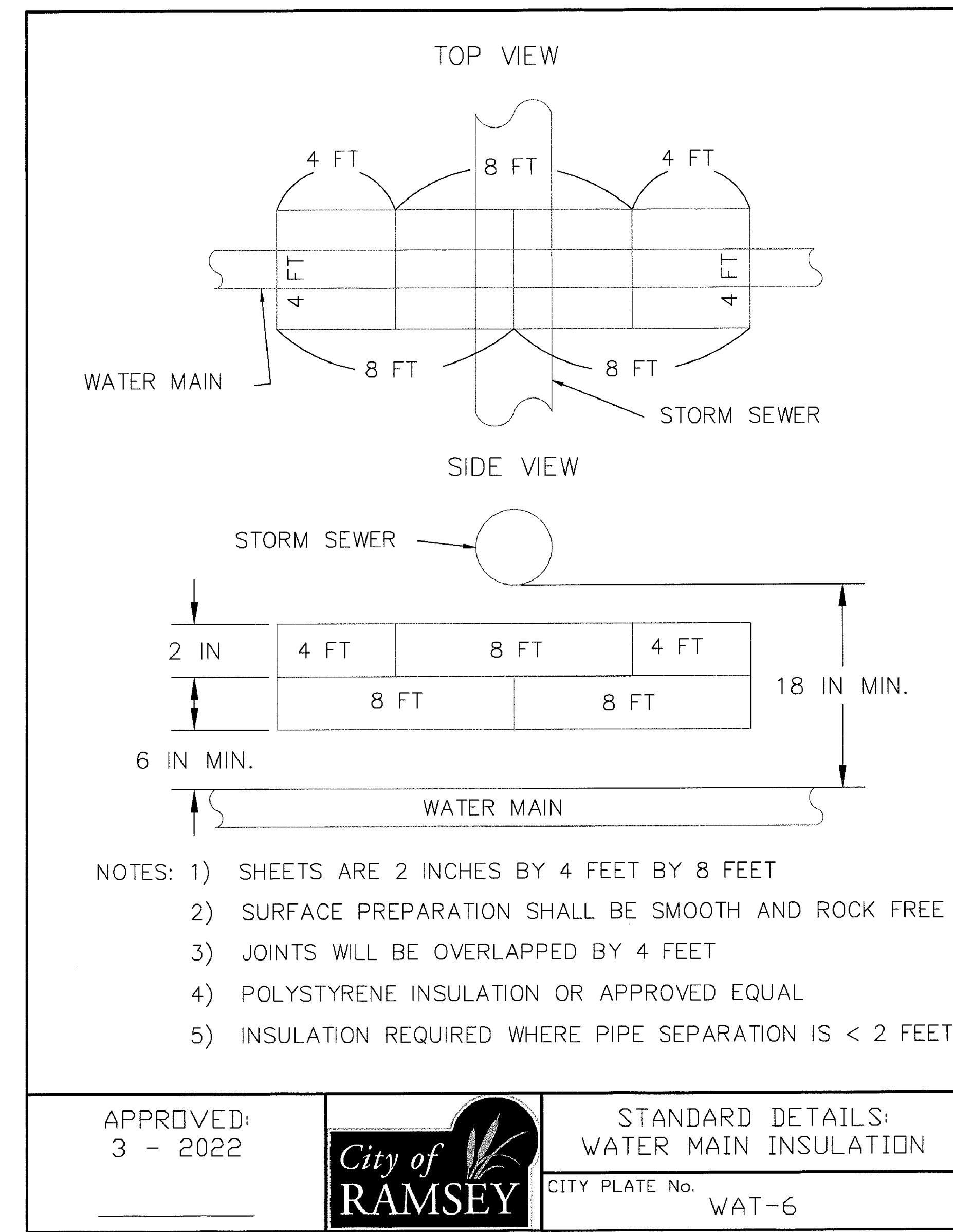
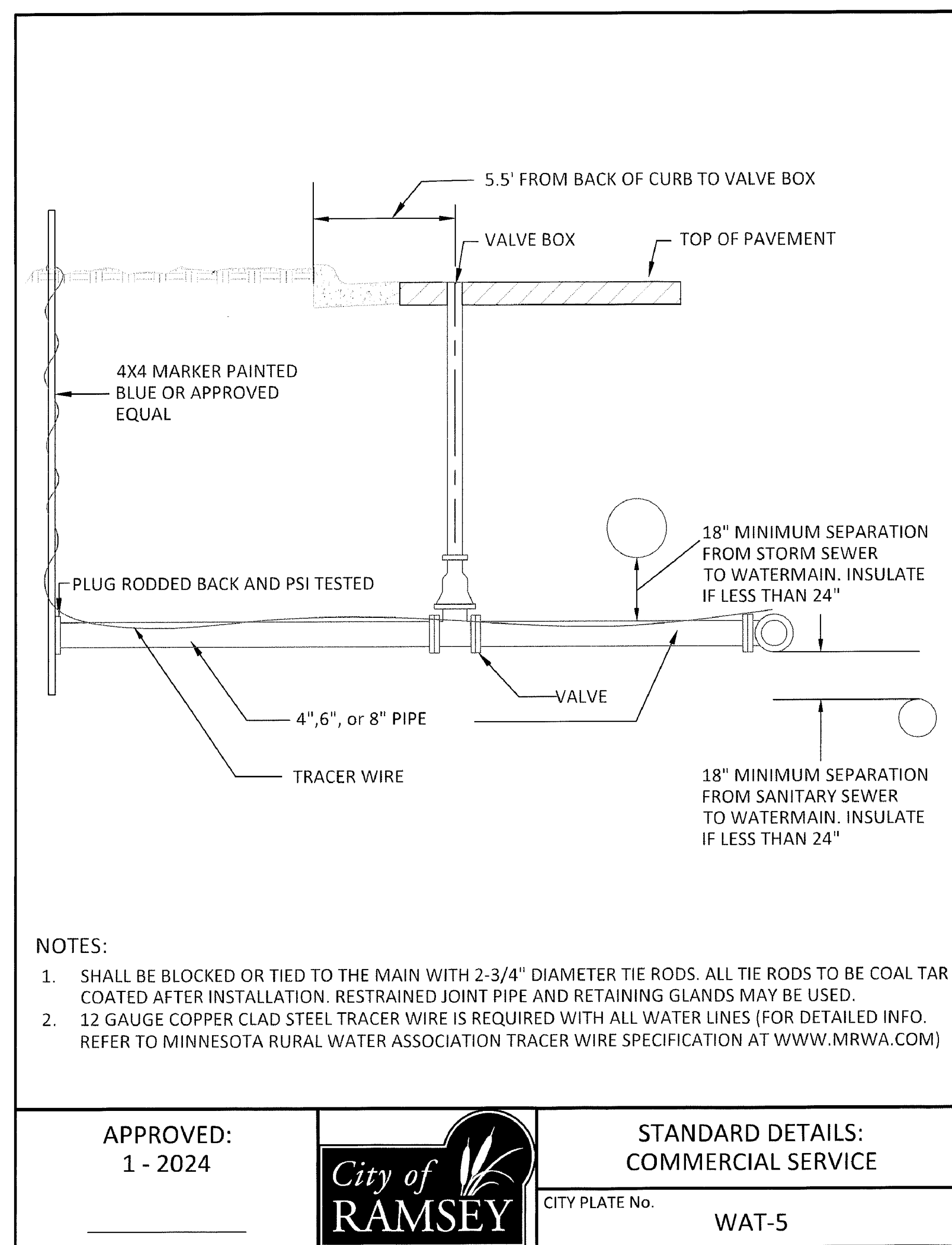
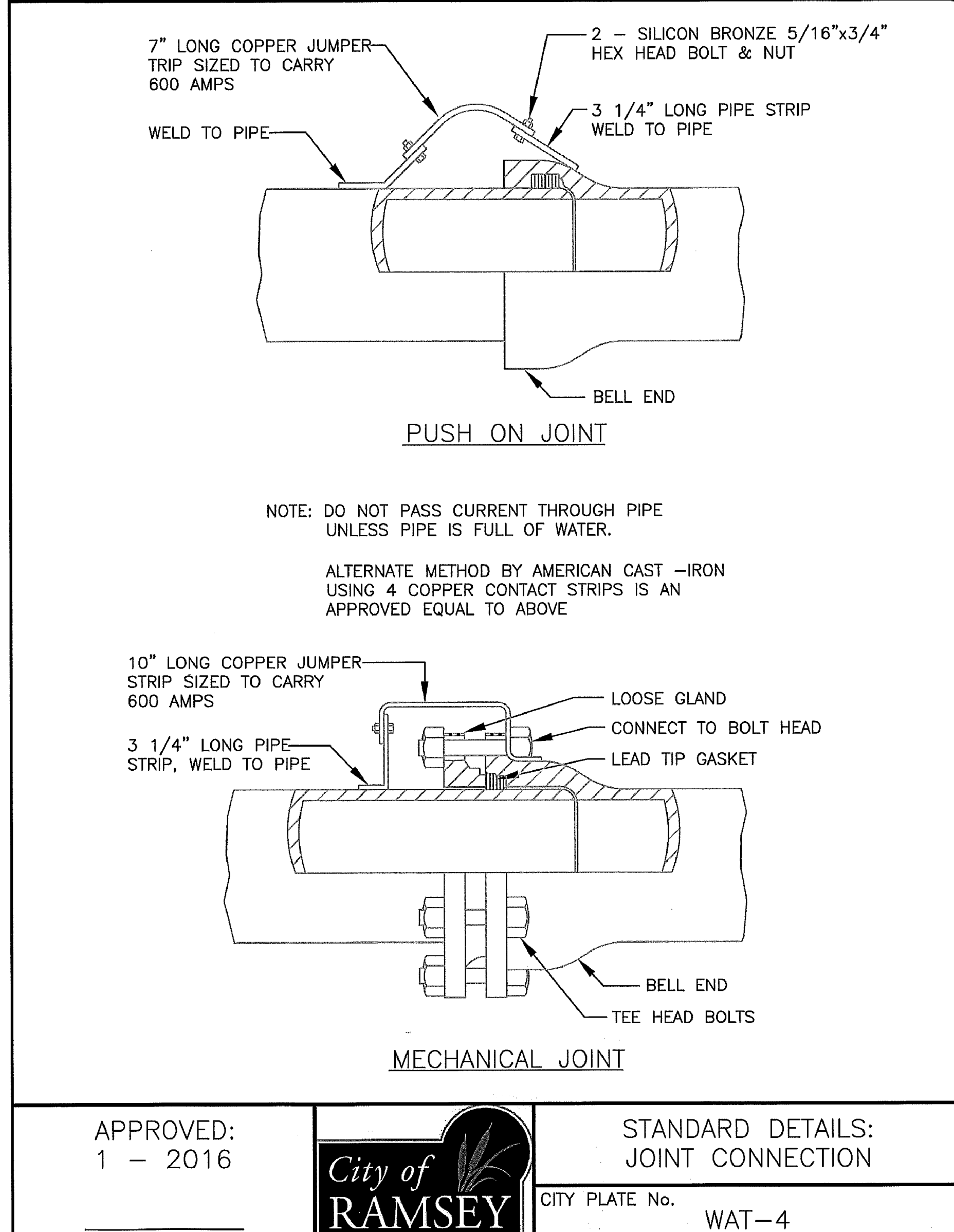
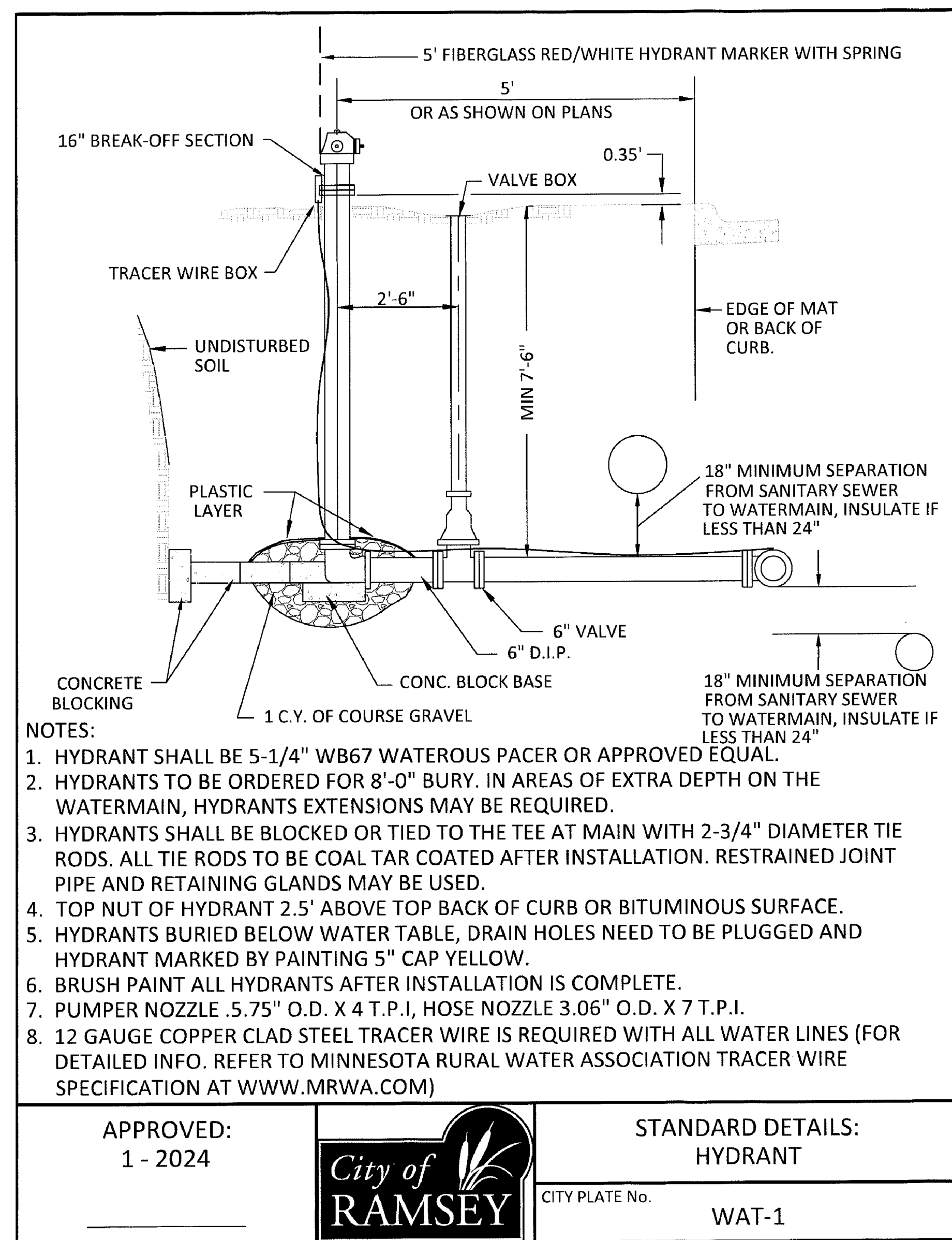

DATE	REVISION	DATE	REVISION
3/13/24	PLAN REVISIONS PER CITY REVIEW		

I hereby certify that this plan, specification, or report was prepared by me or under my direct supervision and that I am a duly Licensed Professional Engineer under the laws of the State of Minnesota.

Timothy A. Esberichs, P.E.

TIMOTHY A. ESBERICHS, P.E.
Date 2/12/24 Lic. No. 43362

DESIGNED BY: TAE
DRAWN BY: TAE
CHECKED BY: CJJ

Hakanson Anderson
Civil Engineers and Land Surveyors
3601 Thurston Ave., Anoka, Minnesota 55303
763-427-5860 FAX 763-427-0520
www.hakanson-anderson.com

ST. KATHARINE DREXEL

CITY STANDARD PLATES
CITY OF RAMSEY, MINNESOTA

SHEET C6 OF C13 SHEETS 4719.02

SIGNIFICANT TREE INVENTORY TABULATION			
Tree Number	Common Name	Diameter (inches)	Action
1	Jack Pine	12	Protect
2	Jack Pine	16	Protect
3	Jack Pine	8	Protect
4	Jack Pine	10	Protect
5	Jack Pine	8	Protect
6	Jack Pine	6	Protect
7	Jack Pine	4	Protect
10	Jack Pine	14	Protect
11	Jack Pine	12	Protect
12	Jack Pine	10	Protect
14	Red Pine	18	Protect
15	Red Pine	17	Protect
16	Red Pine	17	Protect
17	Red Pine	6	Protect
18	Red Pine	12	Protect
19	Red Pine	10	Protect
20	Jack Pine	14	Protect
21	Red Pine	18	Protect
22	Red Pine	18	Protect
23	Jack Pine	10	Protect
24	Red Pine	15	Protect
25	Red Pine	17	Protect
26	Jack Pine	24	Protect
27	Red Pine	19	Protect
28	Red Pine	8	Protect
30	Red Pine	18	Protect
31	Red Pine	18	Protect
32	Red Pine	18	Protect
33	Jack Pine	15	Protect
34	Red Pine	12	Protect
35	Red Pine	12	Protect
36	Red Pine	18	Protect
37	Red Pine	14	Protect
38	Red Pine	14	Protect
41	Red Pine	8	Protect
42	Green Ash	24	Protect
43	Cottonwood	24	Protect
45	Red Pine	8	Protect
46	Red Pine	10	Protect
47	Red Pine	12	Protect
48	Red Pine	10	Protect
49	Red Pine	14	Protect
50	Red Pine	8	Protect
51	Red Pine	7	Protect
52	Red Pine	10	Protect
55	Red Pine	8	Protect
56	Red Pine	10	Protect
57	Red Pine	8	Protect
58	Red Pine	6	Protect
59	Red Pine	8	Protect
60	Red Pine	10	Protect
61	Red Pine	16	Protect
62	Red Pine	12	Protect
63	Red Pine	10	Protect
64	Red Pine	7	Protect
65	Red Pine	10	Protect
67	Red Pine	14	Protect
68	Red Pine	14	Protect
69	Red Pine	10	Clear & Grub - Storm Sewer
70	Red Pine	10	Clear & Grub - Storm Sewer
71	Red Pine	10	Clear & Grub - Storm Sewer
72	Red Pine	10	Clear & Grub - Storm Sewer
73	Red Pine	12	Clear & Grub - Storm Sewer
74	Red Pine	10	Clear & Grub - Storm Sewer
75	Red Pine	12	Clear & Grub - Storm Sewer
76	Red Pine	14	Clear & Grub - Storm Sewer
77	Red Pine	12	Clear & Grub - Storm Sewer
78	Red Pine	12	Clear & Grub - Storm Sewer
80	Red Pine	10	Clear & Grub - Storm Sewer
81	Red Pine	10	Clear & Grub - Storm Sewer
82	Red Pine	12	Clear & Grub - Storm Sewer
83	Red Pine	14	Clear & Grub - Storm Sewer
84	Red Pine	11	Clear & Grub - Storm Sewer
85	Red Pine	12	Clear & Grub - Storm Sewer
86	Red Pine	14	Clear & Grub - Storm Sewer
87	Red Pine	12	Clear & Grub - Storm Sewer
89	Red Pine	10	Clear & Grub - Storm Sewer
92	White Ash	16	Protect
93	Red Pine	14	Clear & Grub - Sidewalk
94	Red Pine	16	Clear & Grub - Sidewalk
95	Red Pine	14	Clear & Grub - Sidewalk
96	Red Pine	11	Clear & Grub - Sidewalk
97	Red Pine	12	Protect
98	Red Pine	17	Protect
99	Red Pine	8	Protect
100	Red Pine	12	Protect
101	Red Pine	13	Protect
103	Cottonwood	16	Protect
104	Red Pine	13	Protect
105	Red Pine	18	Protect
106	Red Oak	10	Protect
107	White Ash	10	Protect
109	Red Pine	14	Protect
110	Red Pine	13	Protect
111	Red Pine	12	Protect
112	Red Pine	13	Protect
113	Red Pine	8	Clear & Grub - Storm Sewer
114	Red Pine	14	Protect
116	Red Pine	12	Protect
117	Red Pine	13	Clear & Grub - Storm Sewer
118	Red Pine	11	Protect
119	White Ash	12	Clear & Grub - Storm Sewer
120	Red Pine	8	Protect
121	Red Pine	10	Clear & Grub - Storm Sewer
122	Red Pine	10	Clear & Grub - Storm Sewer
123	Red Pine	8	Clear & Grub - Storm Sewer
124	Red Pine	8	Clear & Grub - Storm Sewer
125	Red Pine	14	Clear & Grub - Storm Sewer
126	Red Pine	10	Clear & Grub - Storm Sewer
127	Red Pine	9	Clear & Grub - Storm Sewer

SIGNIFICANT TREE INVENTORY TABULATION			
Tree Number	Common Name	Diameter (inches)	Action
128	Red Pine	9	Clear & Grub - Storm Sewer
129	Red Pine	8	Clear & Grub - Storm Sewer
130	Cottonwood	26	Clear & Grub - Storm Sewer
132	Red Pine	8	Clear & Grub - Storm Sewer
133	Red Pine	14	Protect
134	Red Pine	11	Protect
135	Red Pine	10	Protect
136	Red Pine	13	Protect
137	Red Pine	10	Protect
138	White Ash	16	Protect
139	Red Pine	8	Protect
140	Red Pine	16	Protect
141	Red Pine	8	Protect
142	Red Pine	12	Protect
143	Red Pine	16	Protect
144	Red Pine	16	Protect
145	Red Pine	18	Protect
148	Green Ash	28	Protect
149	Red Pine	6	Protect
150	Red Pine	10	Protect
151	Red Pine	15	Protect
152	Red Pine	8	Protect
153	Red Pine	12	Protect
154	Red Pine	10	Protect
155	Red Pine	9	Protect
156	Red Pine	13	Protect
158	Green Ash	17	Protect
159	Green Ash	16	Protect
160	Red Pine	10	Protect
161	Red Pine	14	Protect
162	Red Pine	11	Protect
163	Red Pine	8	Protect
164	Red Pine	12	Protect
165	Red Pine	10	Protect
166	Red Pine	14	Protect
167	Red Pine	16	Protect
168	Red Pine	12	Protect
169	Red Pine	14	Protect
170	Red Pine	16	Protect
171	Red Pine	7	Protect
172	Red Pine	4	Protect
173	Red Pine	19	Protect
174	Red Pine	13	Protect
175	Red Pine	20	Protect
176	Red Pine	16	Protect
177	Red Pine	16	Protect
178	Red Pine	12	Protect
179	Red Pine	8	Protect
180	Red Pine	14	Protect
181	Red Pine	14	Clear & Grub - Pond
182	Red Pine	12	Clear & Grub - Pond
183	Red Pine	14	Clear & Grub - Pond
184	Red Pine	11	Clear & Grub - Pond
185	Red Pine	9	Clear & Grub - Pond
186	Red Pine	10	Clear & Grub - Pond
187	Red Pine	10	Clear & Grub - Pond
188	Red Pine	12	Clear & Grub - Pond
189	Red Pine	14	Clear & Grub - Pond
190	Red Pine	12	Clear & Grub - Pond
191	Red Pine	12	Clear & Grub - Pond
192	Jack Pine	10	Clear & Grub - Pond
193	Red Pine	12	Clear & Grub - Pond
194	Red Pine	14	Clear & Grub - Pond
196	Red Pine	23	Clear & Grub - Pond
197	Red Pine	10	Clear & Grub - Pond
198	Jack Pine	5	Clear & Grub - Pond
199	Red Pine	6	Clear & Grub - Pond
200	Jack Pine	8	Clear & Grub - Pond
201	Jack Pine	10	Clear & Grub - Pond
202	Red Pine	11	Clear & Grub - Pond
203	Red Pine	10	Clear & Grub - Pond
204	Jack Pine	10	Clear & Grub - Pond
205	Red Pine	13	Clear & Grub - Pond
206	Red Pine	13	Clear & Grub - Pond
207	Red Pine	6	Clear & Grub - Pond
208	Red Pine	13	Clear & Grub - Pond
209	Red Pine	15	Clear & Grub - Pond
210	Red Pine	12	Clear & Grub - Pond
211	Red Pine	11	Clear & Grub - Pond
212	Red Pine	11	Clear & Grub - Pond
213	Red Pine	14	Clear & Grub - Pond
214	Red Pine	14	Clear & Grub - Pond
215	Red Pine	14	Clear & Grub - Pond
216	Red Pine	17	Clear & Grub - Pond
217	Red Pine	14	Clear & Grub - Pond
218	Red Pine	16	Clear & Grub - Pond
219	Red Pine	12	Clear & Grub - Pond
223	Red Pine	16	Clear & Grub - Pond
224	Red Pine	12	Clear & Grub - Pond
225	Red Pine	5	Clear & Grub - Pond
226	Red Pine	5	Clear & Grub - Pond
227	Red Pine	4	Clear & Grub - Pond
229	Red Pine	14	Clear & Grub - Pond
230	Green Ash	12	Protect
232	Cottonwood	40	Protect
233	Red Oak	20	Protect
234	Quaking Aspen	9	Protect
237	Boxelder	40	Clear & Grub - Pond
239	Boxelder	20	Protect
241	White Ash	13	Clear & Grub - Pond
242	Red Cedar	9	Clear & Grub - Pond
243	Red Cedar	7	Clear & Grub - Pond
245	Red Cedar	12	Clear & Grub - Pond
246	Red Cedar	7	Clear & Grub - Pond
249	Boxelder	21	Clear & Grub - Pond
250	White Ash	18	Clear & Grub - Pond
253	White Ash	14	Protect
256	Red Pine	10	Protect

SIGNIFICANT TREE INVENTORY TABULATION			
Tree Number	Common Name	Diameter (inches)	Action
257	Red Cedar	8	Protect
258	Red Pine	12	Protect
259	Red Cedar	4	Protect
260	Red Pine	16	Protect
262	Peachleaf Willow	52	Protect
265	Boxelder	11	Clear & Grub - Pond
266	White Oak	7	Clear & Grub - Pond
267	White Oak	5	Clear & Grub - Pond
268	Red Cedar	13	Protect
269	White Oak	9	Clear & Grub - Pond
287	Red Oak	6	Protect
289	Bur Oak	6	Protect
290	Bur Oak	16	Protect
291	Bur Oak	21	Protect
293	Red Oak	6	Protect
296	Bur Oak	19	Protect
302	Bur Oak	16	Protect
303	Bur Oak	14	Protect
304	Bur Oak	24	Protect
305	Red Cedar	9	Protect
308	Bur Oak	24	Protect
309	Jack Pine	4	Protect
310	Bur Oak	12	Protect
312	Bur Oak	8	Protect
313	Bur Oak	8	Protect
314	Bur Oak	10	Protect
315	Red Oak	12	Protect
316	Bur Oak	12	Protect
317	Jack Pine	4	Protect
318	Red Oak	15	Protect
322	Red Cedar	20	Protect
323	Jack Pine	16	Protect
324	Red Cedar	11	Protect
325	Red Oak	6	Protect
327	Jack Pine	12	Protect
328	Jack Pine	13	Protect
330	Jack Pine	12	Protect
331	Jack Pine	16	Protect
332	Jack Pine	6	Protect
333	Jack Pine	14	Protect
334	Jack Pine	13	Protect
335	Jack Pine	8	Protect
336	Jack Pine	10	Protect
337	Jack Pine	25	Protect
338	Red Cedar	18	Protect
340	Red Pine	17	Protect
341	Red Pine	12	Clear & Grub - Parking Lot
342	Red Pine	15	Clear & Grub - Parking Lot
343	Red Pine	16	Protect
344	Red Pine	6	Protect
345	Red Pine	10	Protect
346	Red Pine	12	Protect
347	Jack Pine	5	Protect
348	Red Pine	8	Protect
349	Red Pine	14	Protect
350	Red Pine	10	Protect
351	Red Pine	6	Clear & Grub - Building
352	Red Pine	15	Clear & Grub - Building
353	Red Pine	9	Clear & Grub - Building
354	Red Pine	11	Clear & Grub - Building
355	Red Pine	15	Clear & Grub - Building
357	Red Pine	14	Clear & Grub - Building
358	Red Pine	17	Clear & Grub - Building
360	Red Pine	12	Clear & Grub - Building
361	Red Pine	17	Clear & Grub - Building
362	Red Cedar	10	Clear & Grub - Building
363	Bur Oak	22	Clear & Grub - Building
364	Bur Oak	17	Clear & Grub - Building
365	Bur Oak	20	Clear & Grub - Building
366	Bur Oak	26	Clear & Grub - Building
367	Red Pine	14	Clear & Grub - Building
368	Red Pine	14	Clear & Grub - Building
369	Red Pine	12	Clear & Grub - Building
370	Red Pine	14	Clear & Grub - Building
371	Red Pine	17	Clear & Grub - Building
372	Red Pine	12	Clear & Grub - Building
373	Red Pine	13	Clear & Grub - Building
375	Red Pine	17	Clear & Grub - Building
376	Red Pine	9	Protect
377	Red Pine	12	Protect
378	Red Pine	12	Protect
379	Red Pine	13	Protect
380	Red Pine	14	Protect
385	Red Cedar	6	Clear & Grub - Parking Lot
386	Red Cedar	12	Clear & Grub - Parking Lot
387	Red Cedar	12	Clear & Grub - Parking Lot
388	Red Cedar	17	Clear & Grub - Parking Lot
389	Red Pine	11	Clear & Grub - Parking Lot
390	Red Pine	16	Protect
391	Red Pine	15	Protect
393	White Pine	18	Clear & Grub - Building
394	Red Pine	19	Clear & Grub - Building
395	White Pine	21	Clear & Grub - Building
396	White Pine	16	Clear & Grub - Building
398	Bur Oak	27	Clear & Grub - Parking Lot
399	Bur Oak	20	Protect
400	Bur Oak	20	Clear & Grub - Parking Lot
402	Bur Oak	23	Protect
406	Red Cedar	23	Clear & Grub - Parking Lot
407	Red Cedar	30	Protect
408	Hackberry	25	Protect
409	Cottonwood	39	Protect
410	Siberian Elm	12	Protect
411	Siberian Elm	26	Protect
412	Red Cedar	17	Protect
413	Green Ash	13	Protect
414	Red Pine	13	Protect
415	Red Pine	11	Protect
416	Red Pine	16	Protect
417	Red Pine	13	Protect
418	Red Pine	14	Protect

SIGNIFICANT TREE INVENTORY TABULATION			
Tree Number	Common Name	Diameter (inches)	Action
419	White Ash	22	Protect
420	White Ash	16	Clear & Grub - Parking Lot
422	Red Cedar	15	Clear & Grub - Parking Lot
423	Red Cedar	17	Clear & Grub - Parking Lot
424	Hackberry	24	Clear & Grub - Parking Lot
425	Bur Oak	30	Clear & Grub - Parking Lot

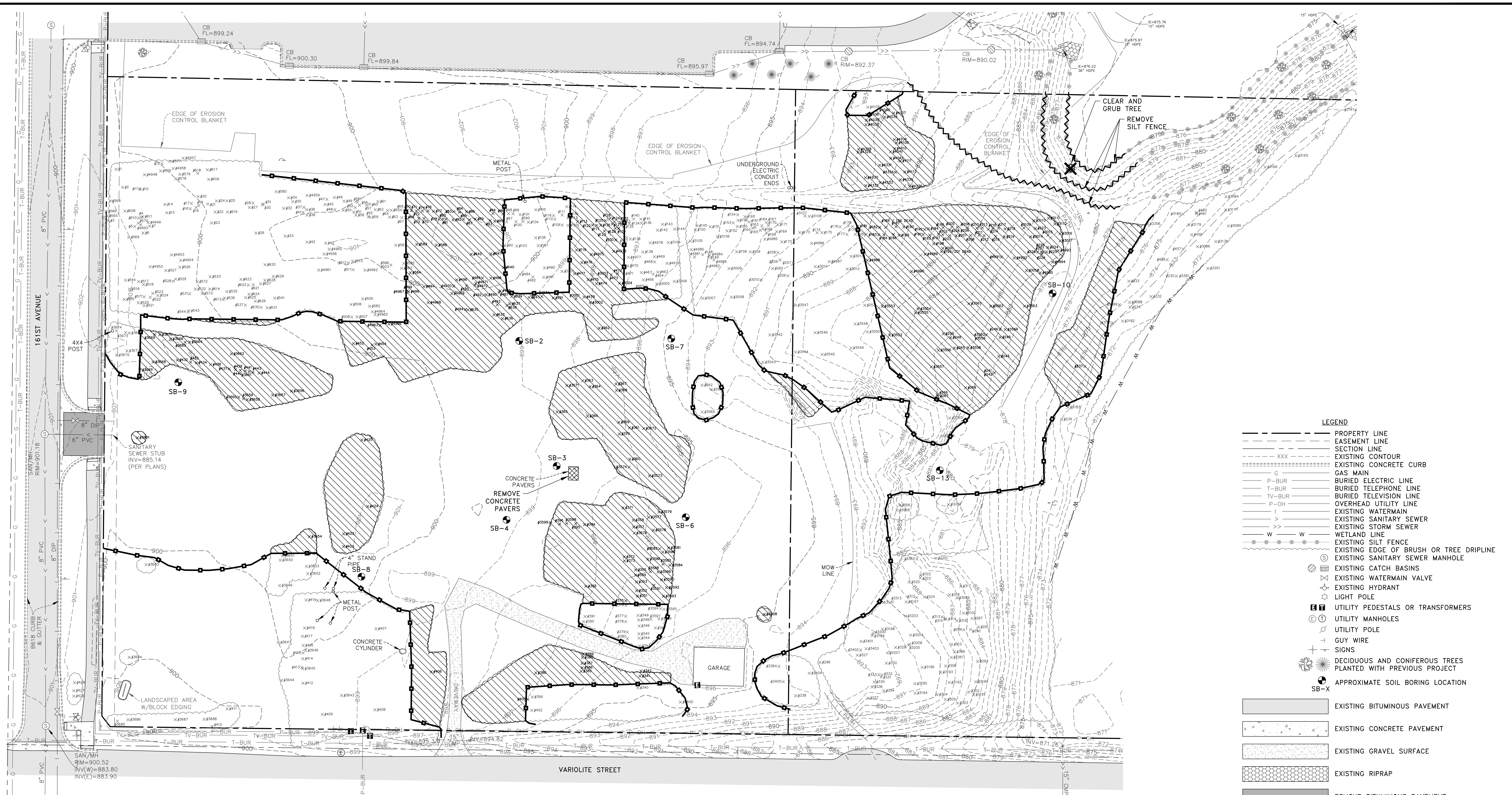

- LEGEND**
- PROPERTY LINE
 - EASEMENT LINE
 - SECTION LINE
 - XXX EXISTING CONTOUR
 - EXISTING CONCRETE CURB
 - G GAS MAIN
 - P-BUR BURIED ELECTRIC LINE
 - T-BUR BURIED TELEPHONE LINE
 - TV-BUR BURIED TELEVISION LINE
 - P-OH OVERHEAD UTILITY LINE
 - I EXISTING WATERMAIN
 - - - EXISTING SANITARY SEWER
 - - - EXISTING STORM SEWER
 - - - W WETLAND LINE
 - EXISTING SILT FENCE
 - EXISTING EDGE OF BRUSH OR TREE DRIPLINE
 - ⊙ EXISTING SANITARY SEWER MANHOLE
 - ⊙ EXISTING CATCH BASINS
 - ⊙ EXISTING WATERMAIN VALVE
 - ⊙ EXISTING HYDRANT
 - ⊙ LIGHT POLE
 - ⊙ UTILITY PEDESTALS OR TRANSFORMERS
 - ⊙ UTILITY MANHOLES
 - ⊙ UTILITY POLE
 - ⊙ GUY WIRE
 - ⊙ SIGNS
 - ⊙ DECIDUOUS AND CONIFEROUS TREES PLANTED WITH PREVIOUS PROJECT
 - ⊙ SB-X APPROXIMATE SOIL BORING LOCATION
 - EXISTING BITUMINOUS PAVEMENT
 - EXISTING CONCRETE PAVEMENT
 - EXISTING GRAVEL SURFACE
 - EXISTING RIPRAP
 - REMOVE BITUMINOUS PAVEMENT
 - CLEAR AND GRUB TREES
 - TREE PROTECTION FENCE ①
 - TREE NUMBER ②

GENERAL NOTES:

- SILT FENCE/TREE PROTECTION FENCE SHALL BE IN PLACE PRIOR TO THE START OF ANY REMOVAL ACTIVITIES. SEE THE GRADING, DRAINAGE AND EROSION CONTROL PLAN FOR SILT FENCE LOCATIONS.
- CLEARING OF ANY OAK TREES SHALL NOT OCCUR PRIOR TO JULY 15TH. IF OAK TREE CLEARING IS NECESSARY PRIOR TO JULY 15TH, AN OAK WILT MANAGEMENT PLAN MUST BE PREPARED AND SUBMITTED TO THE CITY FOR REVIEW TO ENSURE ADEQUATE MEASURES ARE IMPLEMENTED TO PROTECT FROM THE INTRODUCTION OF OAK WILT.
- CLEAR AND GRUB BRUSH, SHRUBS AND SMALL TREES WITHIN THE CONSTRUCTION LIMITS (NOT SHOWN).

REFERENCE NOTES:

- FENCE MATERIAL SHALL MEET THE REQUIREMENTS OF CITY PLATE NO. ERO-8. FENCE SHALL BE INSTALLED PER MN/DOT SPEC. 2572.3.A.1.
- ONLY THE SIGNIFICANT TREES, AS DEFINED BY THE CITY OF RAMSEY, ARE NUMBERED. SEE SHEET C7 FOR THE SIGNIFICANT TREE INVENTORY TABULATION.

DATE	REVISION	DATE	REVISION
3/13/24	PLAN REVISIONS PER CITY REVIEW		
3/19/20	PLAN REVISIONS PER CLIENT REVIEW		

I hereby certify that this plan, specification, or report was prepared by me or under my direct supervision and that I am a duly Licensed Professional Engineer under the laws of the State of Minnesota.

Timothy A. Ebersbach, P.E.
 Date 2/12/24 Lic. No. 43362

DESIGNED BY: TAE
 DRAWN BY: TAE
 CHECKED BY: CJJ

Hakanson Anderson
 Civil Engineers and Land Surveyors
 3601 Thurston Ave., Anoka, Minnesota 55303
 763-427-5860 FAX 763-427-0520
 www.hakanson-anderson.com

ST. KATHARINE DREXEL

EXISTING TOPOGRAPHY AND REMOVALS PLAN

CITY OF RAMSEY, MINNESOTA

SHEET C8 OF C13 SHEETS

4719.02

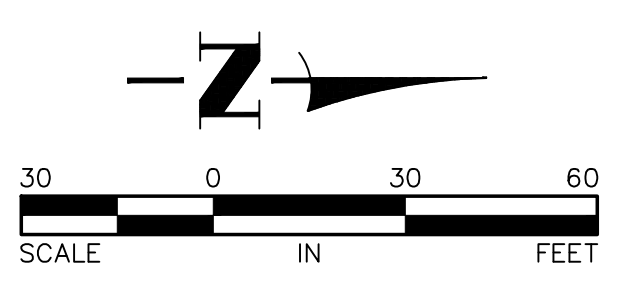

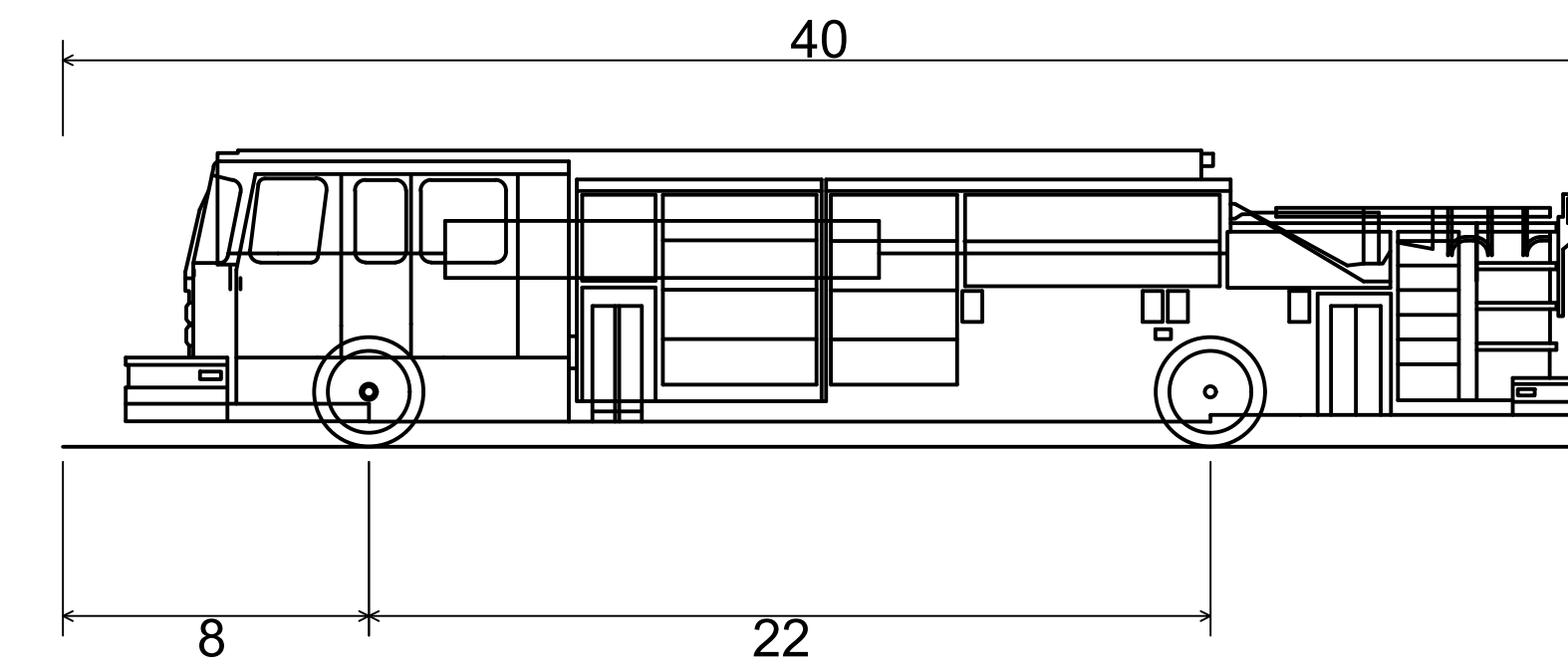

Pumper Fire Truck
 Overall Length 40.00ft
 Overall Width 8.167ft
 Overall Body Height 7.745ft
 Min Body Ground Clearance 0.656ft
 Track Width 8.167ft
 Lock-to-lock time 5.00s
 Max Wheel Angle 45.00°

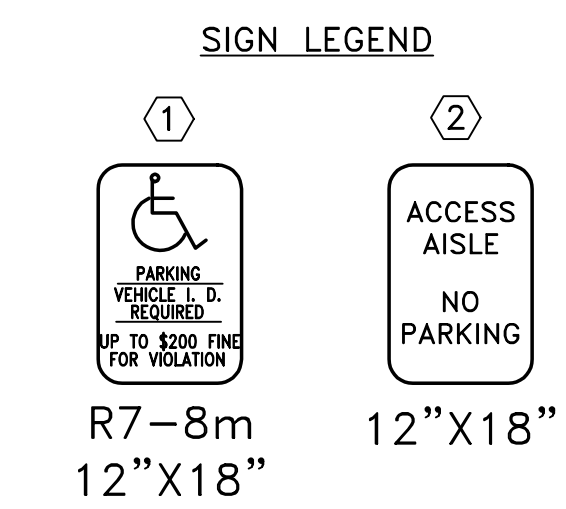
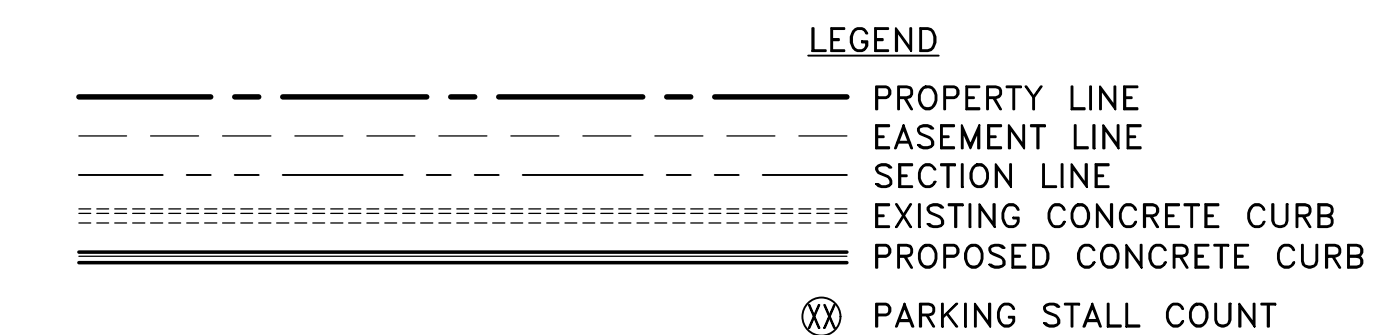

LEGAL DESCRIPTION
 LOT 1, BLOCK 1-ST. KATHARINE DREXEL CHURCH ADDITION
 ZONING: PI: PUBLIC/INSTITUTIONAL

LOT SUMMARY

TOTAL LOT AREA=	277,969 SF
PHASE 1 DISTURBED AREA=	206,140 SF ①
PRE-CONSTRUCTION IMPERVIOUS AREA=	6,360 SF
POST CONSTRUCTION IMPERVIOUS AREA (PHASE 1)=	72,025 SF (26%)
POST CONSTRUCTION IMPERVIOUS AREA (PHASES 1 & 2)	197,255 SF (71%)
BUILDING COVERAGE AREA (PHASE 1)	17,112 SF (6%) ③
BUILDING COVERAGE AREA (PHASES 1 & 2)	43,991 SF (16%) ③
GREEN SPACE AREA (PHASE 1)	205,944 SF (74%)
GREEN SPACE AREA (PHASES 1 & 2)	80,714 SF (29%)

PARKING SUMMARY

PROPOSED PARKING STALLS (PHASE 1)	98
PROPOSED PARKING STALLS (PHASES 1 & 2)	387

REFERENCE NOTES:
 ① INCLUDES AREA OUTSIDE THE PROPERTY BOUNDARY.
 ② NO PARKING-FIRE LANE. CURB SHALL BE PAINTED YELLOW.
 ③ AREA INCLUDES EXISTING 1,200 SQUARE FOOT GARAGE.

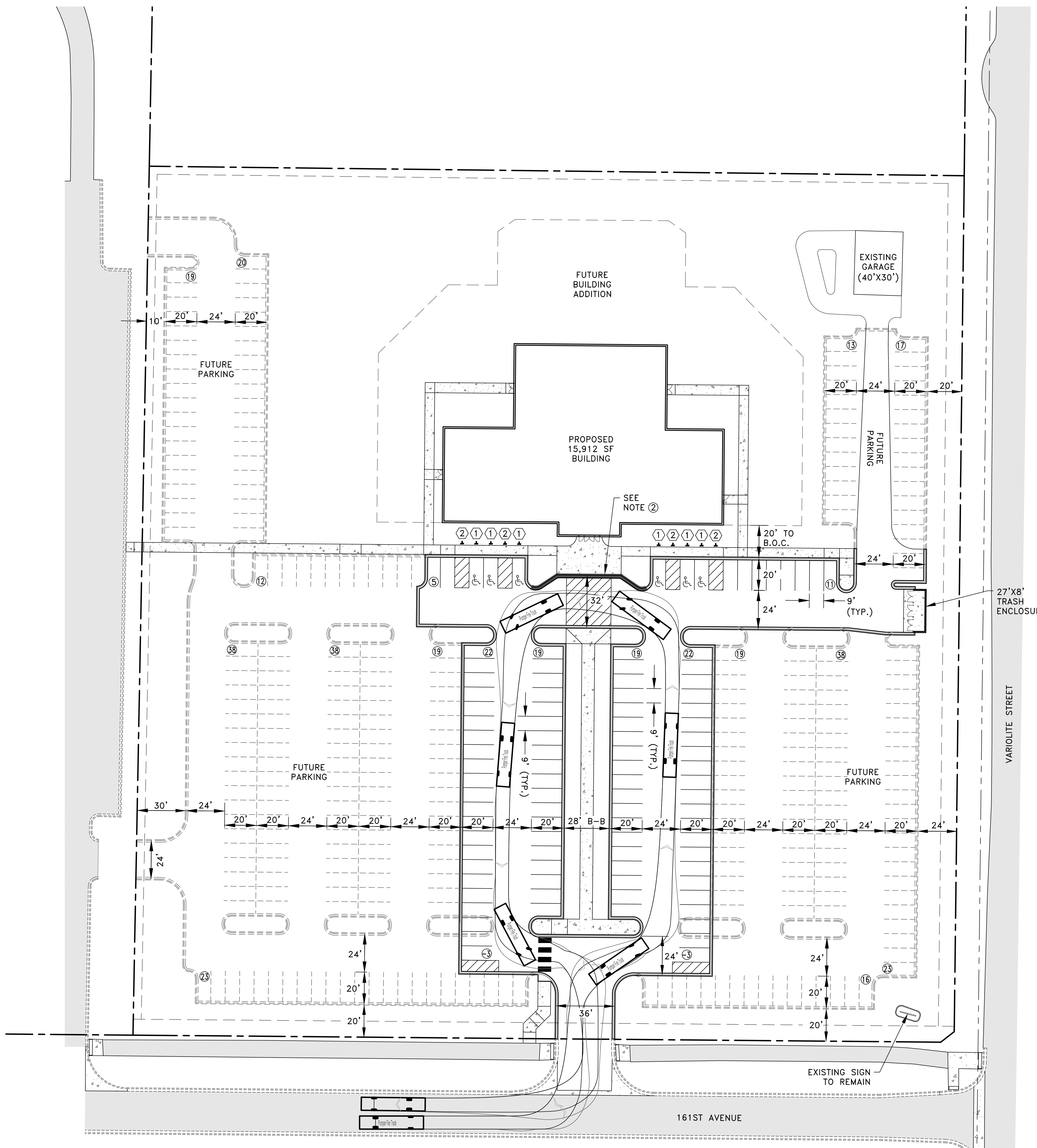

27'x8' TRASH ENCLOSURE
 VARIOLITE STREET

EXISTING SIGN TO REMAIN

161ST AVENUE

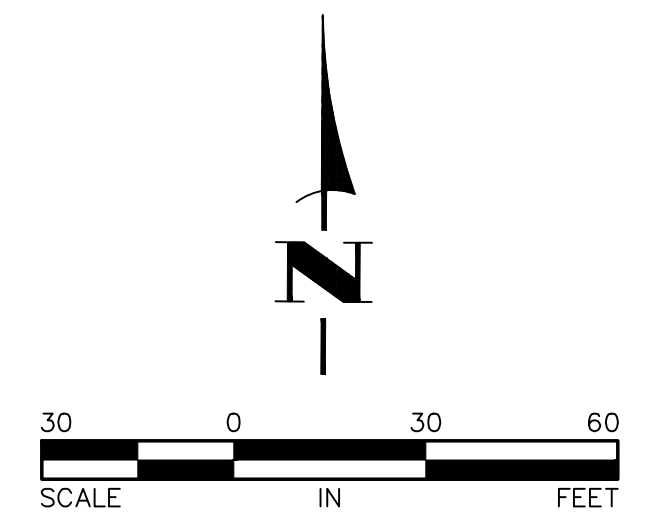

4/15/2024 11:19:20 AM ENGINEERING PLAN DWG A71952 SITE.Plg

DATE	REVISION	DATE	REVISION
3/13/24	PLAN REVISIONS PER CITY REVIEW		
3/19/20	PLAN REVISIONS PER CLIENT REVIEW		

I hereby certify that this plan, specification, or report was prepared by me or under my direct supervision and that I am a duly Licensed Professional Engineer under the laws of the State of Minnesota.

Timothy A. Ebersbach
 TIMOTHY A. EBERSBACH, P.E.
 Date 2/12/24 Lic. No. 43362

DESIGNED BY: TAE
 DRAWN BY: TAE
 CHECKED BY: CJJ



Hakanson Anderson
 Civil Engineers and Land Surveyors
 3601 Thurston Ave., Anoka, Minnesota 55303
 763-427-5860 FAX 763-427-0520
 www.hakanson-anderson.com

ST. KATHARINE DREXEL

SITE PLAN

CITY OF RAMSEY, MINNESOTA

SHEET C9 OF C13 SHEETS
 4719.02

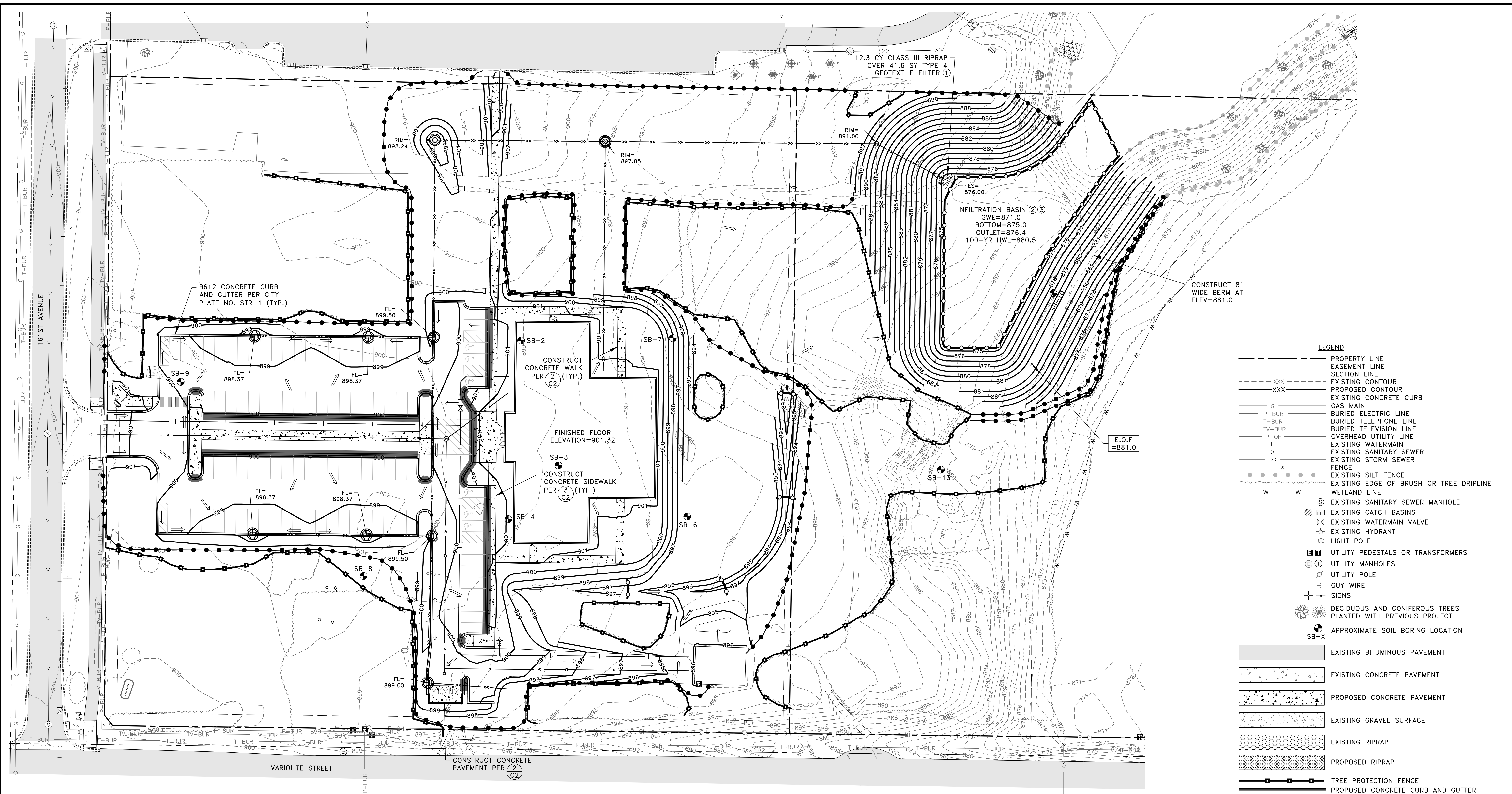

12.3 CY CLASS III RIPRAP
OVER 41.6 SY TYPE 4
GEOTEXTILE FILTER ①

INFILTRATION BASIN ② ③
GWE=871.0
BOTTOM=875.0
OUTLET=876.4
100-YR HWL=880.5

B612 CONCRETE CURB
AND GUTTER PER CITY
PLATE NO. STR-1 (TYP.)

CONSTRUCT
CONCRETE WALK
PER ② (TYP.)

FINISHED FLOOR
ELEVATION=901.32

CONSTRUCT
CONCRETE SIDEWALK
PER ③ (TYP.)

E.O.F.
=881.0

- GENERAL NOTES:**
- PRIOR TO IMPORTING OR EXPORTING MATERIAL FROM THE SITE, CONTRACTOR SHALL CONSTRUCT ROCK CONSTRUCTION ENTRANCES AS NEEDED PER CITY PLATE NO. ERO-5. ROCK CONSTRUCTION ENTRANCES SHALL HAVE A MINIMUM HEIGHT OF 2 FEET.
 - VERIFY BUILDING DIMENSIONS WITH ARCHITECTURAL PLANS.
 - SEE SHEET C11 FOR THE STAKING PLAN.
 - SEE SHEET C12 FOR THE UTILITY PLAN.
 - SEE SHEET C13 FOR THE RESTORATION AND PAVING PLAN.
 - CONTRACTOR SHALL IMMEDIATELY INITIATE STABILIZATION OF EXPOSED SOIL AREAS AND COMPLETE STABILIZATION WITHIN SEVEN CALENDAR DAYS AFTER THE CONSTRUCTION ACTIVITY IN THAT PORTION OF THE SITE TEMPORARILY OR PERMANENTLY CEASES.
 - CONTRACTOR SHALL DETERMINE A LOCATION FOR CONCRETE AND OTHER WASHOUT WASTE. A SIGN SHALL BE INSTALLED ADJACENT TO EACH WASHOUT FACILITY THAT REQUIRES SITE PERSONNEL TO UTILIZE THE PROPER FACILITIES FOR DISPOSAL OF CONCRETE AND OTHER WASTES.
 - STREET SWEEPING MUST BE PERFORMED DAILY IF SEDIMENT IS TRACKED OUTSIDE THE CONSTRUCTION LIMITS OR ONTO ANY CITY STREETS.
 - PER THE ANOKA COUNTY SOIL SURVEY, THE SITE CONSISTS OF NYMORE LOAMY SAND. SEE THE AVAILABLE GEOTECHNICAL EXPLORATION REPORTS FOR ADDITIONAL INFORMATION.
 - MAXIMUM FINISHED GRADES SLOPES SHALL BE 4:1.
- REFERENCE NOTES:**
- PLACE RIPRAP PER CITY PLATE NO. ERO-3.
 - CONTRACTOR SHALL NOT EXCAVATE THE INFILTRATION BASIN TO FINAL GRADE, OR WITHIN THREE FEET OF FINAL GRADE, UNTIL THE CONTRIBUTING DRAINAGE AREA HAS BEEN CONSTRUCTED AND FULLY STABILIZED UNLESS RIGOROUS EROSION PREVENTION AND SEDIMENT CONTROLS TO KEEP SEDIMENT AND RUNOFF COMPLETELY AWAY FROM THE INFILTRATION BASIN ARE PROVIDED.
 - CONSTRUCT INFILTRATION BASIN PER ④ (C2).
 - PLACE SEDIMENT CONTROL LOG AFTER COMPLETION OF GRADING.
 - PLACE SILT FENCE AT, OR OUTSIDE, THE DRIPLINE OF TREES.

PROJECT SUMMARY—PHASE 1
 DISTURBED AREA = 4.73 ACRES
 EXISTING IMPERVIOUS AREA = 0.15 ACRES
 PROPOSED IMPERVIOUS AREA = 1.65 ACRES

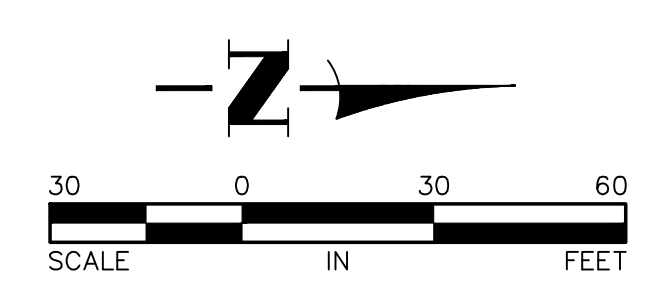

- LEGEND**
- PROPERTY LINE
 - EASEMENT LINE
 - SECTION LINE
 - EXISTING CONTOUR
 - PROPOSED CONTOUR
 - EXISTING CONCRETE CURB
 - GAS MAIN
 - BURIED ELECTRIC LINE
 - BURIED TELEPHONE LINE
 - BURIED TELEVISION LINE
 - OVERHEAD UTILITY LINE
 - EXISTING WATERMAIN
 - EXISTING SANITARY SEWER
 - EXISTING STORM SEWER
 - FENCE
 - EXISTING SILT FENCE
 - EXISTING EDGE OF BRUSH OR TREE DRIPLINE
 - WETLAND LINE
 - EXISTING SANITARY SEWER MANHOLE
 - EXISTING CATCH BASINS
 - EXISTING WATERMAIN VALVE
 - EXISTING HYDRANT
 - LIGHT POLE
 - UTILITY PEDESTALS OR TRANSFORMERS
 - UTILITY MANHOLES
 - UTILITY POLE
 - GUY WIRE
 - SIGNS
 - DECIDUOUS AND CONIFEROUS TREES PLANTED WITH PREVIOUS PROJECT
 - APPROXIMATE SOIL BORING LOCATION
 - EXISTING BITUMINOUS PAVEMENT
 - EXISTING CONCRETE PAVEMENT
 - PROPOSED CONCRETE PAVEMENT
 - EXISTING GRAVEL SURFACE
 - EXISTING RIPRAP
 - PROPOSED RIPRAP
 - TREE PROTECTION FENCE
 - PROPOSED CONCRETE CURB AND GUTTER
 - PROPOSED WATERMAIN
 - PROPOSED SANITARY SEWER
 - PROPOSED STORM SEWER
 - PROPOSED STORM SEWER MANHOLE
 - PROPOSED CATCH BASIN/POND OUTLET STRUCTURE
 - PROPOSED SANITARY SEWER MANHOLE
 - PROPOSED STORM SEWER APRON
 - PROPOSED HYDRANT
 - PROPOSED WATERMAIN VALVE
 - PROPOSED TIPOUT CURB PER ⑤ (C2)
 - SILT FENCE PER CITY PLATE NO. ERO-1 ⑤
 - SEDIMENT CONTROL LOG PER CITY PLATE NO. ERO-4 ④
 - DETAIL NUMBER
 - SHEET NUMBER
 - STORM DRAIN INLET PROTECTION DEVICE PER ② (C3) AND ③ (C3)
 - DRAINAGE ARROW
 - E.O.F. = XXX.X
ELEVATION

DATE	REVISION	DATE	REVISION
3/13/24	PLAN REVISIONS PER CITY REVIEW		
3/19/20	PLAN REVISIONS PER CLIENT REVIEW		

I hereby certify that this plan, specification, or report was prepared by me or under my direct supervision and that I am a duly Licensed Professional Engineer under the laws of the State of Minnesota.
 TIMOTHY A. EISENBERG, P.E.
 Date 2/12/24 Lic. No. 43362

DESIGNED BY: TAE
 DRAWN BY: TAE
 CHECKED BY: CJJ

Hakanson Anderson
 Civil Engineers and Land Surveyors
 3601 Thurston Ave., Anoka, Minnesota 55303
 763-427-5860 FAX 763-427-0520
 www.hakanson-anderson.com

ST. KATHARINE DREXEL

**GRADING, DRAINAGE AND
 SEDIMENT CONTROL PLAN**
 CITY OF RAMSEY, MINNESOTA

SHEET
C10
 OF
C13
 SHEETS
 4719.02

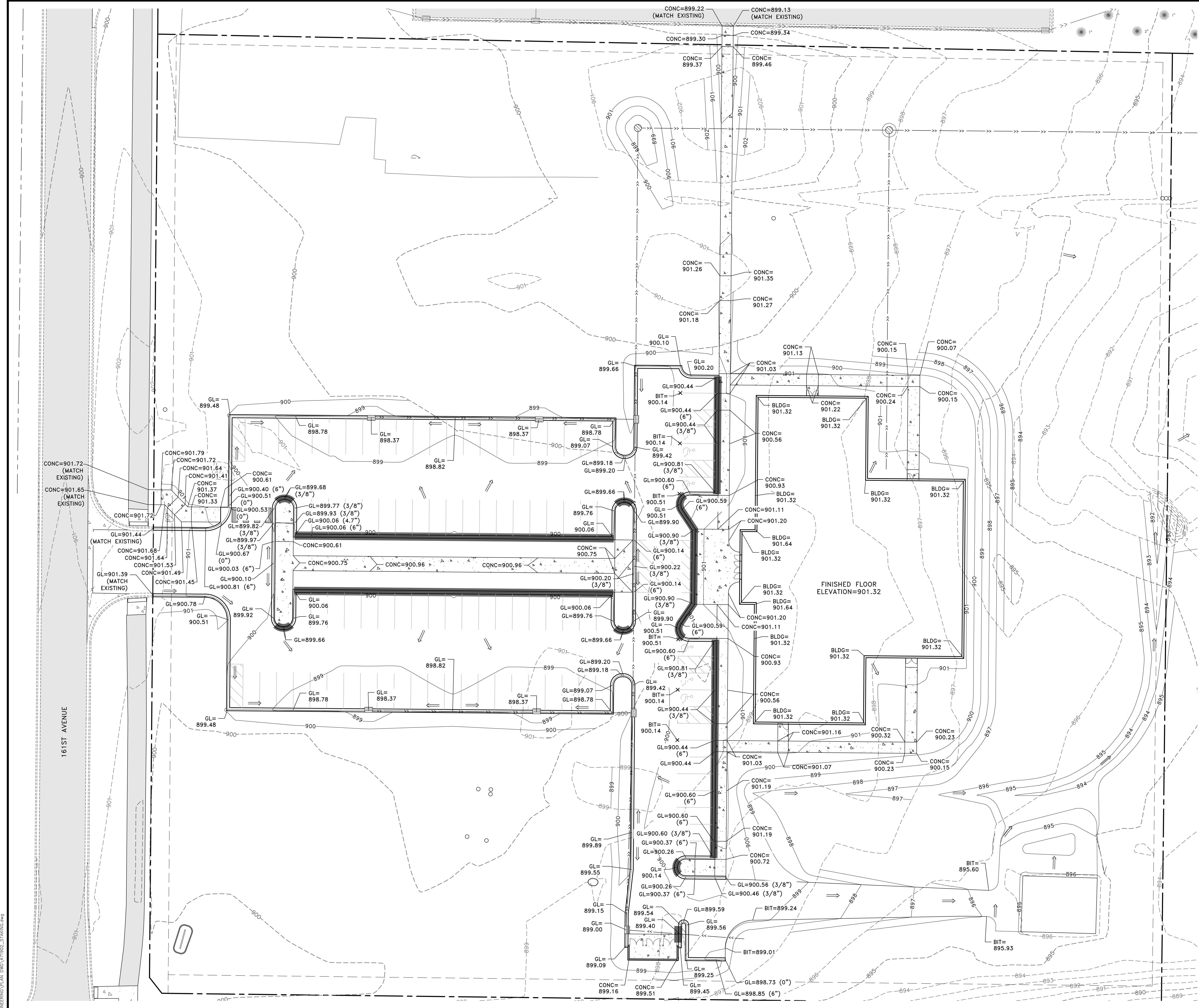

- LEGEND**
- PROPOSED TIPOUT CURB PER 5/2
 - PROPOSED GUTTER LINE ELEVATION
 - PROPOSED SPOT ELEVATION (BITUMINOUS)
 - PROPOSED SPOT ELEVATION (CONCRETE)
 - PROPOSED GROUND ELEVATION AT BUILDING
 - DRAINAGE ARROW

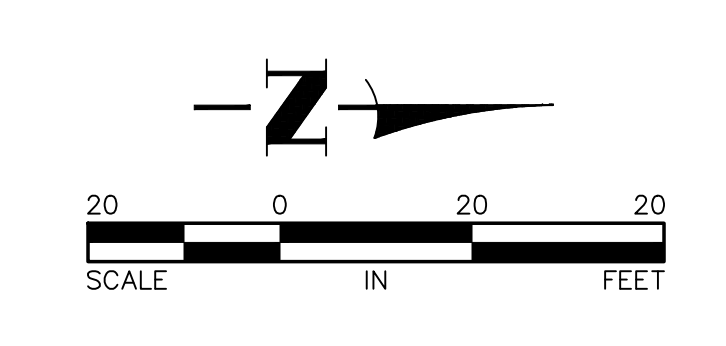

DATE	REVISION
3/13/24	PLAN REVISIONS PER CITY REVIEW
3/19/20	PLAN REVISIONS PER CLIENT REVIEW

DATE	REVISION

I hereby certify that this plan, specification, or report was prepared by me or under my direct supervision and that I am a duly Licensed Professional Engineer under the laws of the State of Minnesota.

Timothy A. Ebersole
 TIMOTHY A. EBERSOLE, P.E.
 Date 2/12/24 Lic. No. 43362

DESIGNED BY: TAE
 DRAWN BY: TAE
 CHECKED BY: CJJ



Hakanson Anderson
 Civil Engineers and Land Surveyors
 3601 Thurston Ave., Anoka, Minnesota 55303
 763-427-5860 FAX 763-427-0520
 www.hakanson-anderson.com

ST. KATHARINE DREXEL

STAKING PLAN
 CITY OF RAMSEY, MINNESOTA

SHEET C11 OF C13 SHEETS
 4719.02

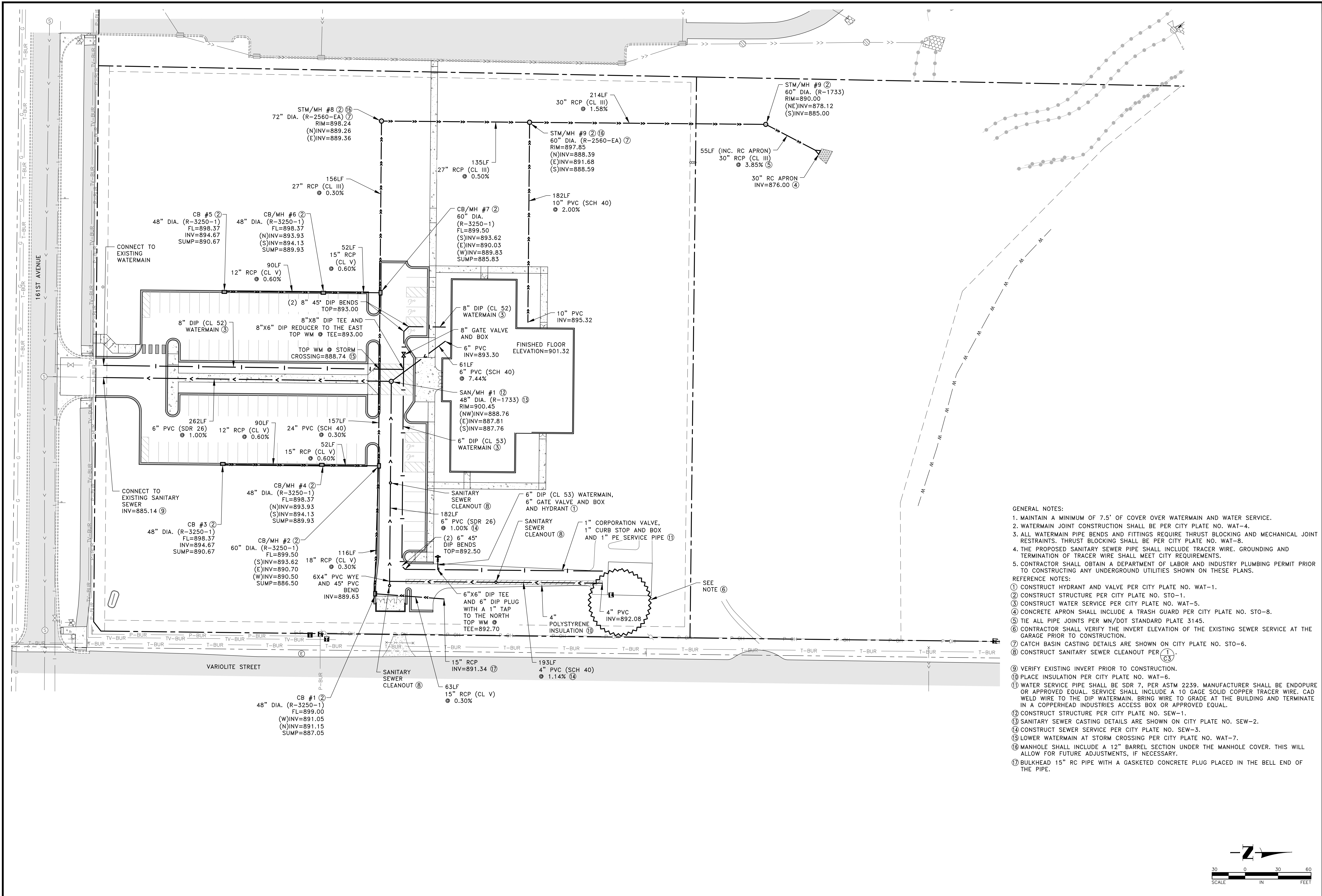

- GENERAL NOTES:
1. MAINTAIN A MINIMUM OF 7.5' OF COVER OVER WATERMAIN AND WATER SERVICE.
 2. WATERMAIN JOINT CONSTRUCTION SHALL BE PER CITY PLATE NO. WAT-4.
 3. ALL WATERMAIN PIPE BENDS AND FITTINGS REQUIRE THRUST BLOCKING AND MECHANICAL JOINT RESTRAINTS. THRUST BLOCKING SHALL BE PER CITY PLATE NO. WAT-8.
 4. THE PROPOSED SANITARY SEWER PIPE SHALL INCLUDE TRACER WIRE. GROUNDING AND TERMINATION OF TRACER WIRE SHALL MEET CITY REQUIREMENTS.
 5. CONTRACTOR SHALL OBTAIN A DEPARTMENT OF LABOR AND INDUSTRY PLUMBING PERMIT PRIOR TO CONSTRUCTING ANY UNDERGROUND UTILITIES SHOWN ON THESE PLANS.
- REFERENCE NOTES:
- ① CONSTRUCT HYDRANT AND VALVE PER CITY PLATE NO. WAT-1.
 - ② CONSTRUCT STRUCTURE PER CITY PLATE NO. STO-1.
 - ③ CONSTRUCT WATER SERVICE PER CITY PLATE NO. WAT-5.
 - ④ CONCRETE APRON SHALL INCLUDE A TRASH GUARD PER CITY PLATE NO. STO-8.
 - ⑤ TIE ALL PIPE JOINTS PER MN/DOT STANDARD PLATE 3145.
 - ⑥ CONTRACTOR SHALL VERIFY THE INVERT ELEVATION OF THE EXISTING SEWER SERVICE AT THE GARAGE PRIOR TO CONSTRUCTION.
 - ⑦ CATCH BASIN CASTING DETAILS ARE SHOWN ON CITY PLATE NO. STO-6.
 - ⑧ CONSTRUCT SANITARY SEWER CLEANOUT PER ① C3.
 - ⑨ VERIFY EXISTING INVERT PRIOR TO CONSTRUCTION.
 - ⑩ PLACE INSULATION PER CITY PLATE NO. WAT-6.
 - ⑪ WATER SERVICE PIPE SHALL BE SDR 7, PER ASTM 2239. MANUFACTURER SHALL BE ENDOPURE OR APPROVED EQUAL. SERVICE SHALL INCLUDE A 10 GAGE SOLID COPPER TRACER WIRE. CAD WELD WIRE TO THE DIP WATERMAIN. BRING WIRE TO GRADE AT THE BUILDING AND TERMINATE IN A COPPERHEAD INDUSTRIES ACCESS BOX OR APPROVED EQUAL.
 - ⑫ CONSTRUCT STRUCTURE PER CITY PLATE NO. SEW-1.
 - ⑬ SANITARY SEWER CASTING DETAILS ARE SHOWN ON CITY PLATE NO. SEW-2.
 - ⑭ CONSTRUCT SEWER SERVICE PER CITY PLATE NO. SEW-3.
 - ⑮ LOWER WATERMAIN AT STORM CROSSING PER CITY PLATE NO. WAT-7.
 - ⑯ MANHOLE SHALL INCLUDE A 12" BARREL SECTION UNDER THE MANHOLE COVER. THIS WILL ALLOW FOR FUTURE ADJUSTMENTS, IF NECESSARY.
 - ⑰ BULKHEAD 15" RC PIPE WITH A GASKETED CONCRETE PLUG PLACED IN THE BELL END OF THE PIPE.

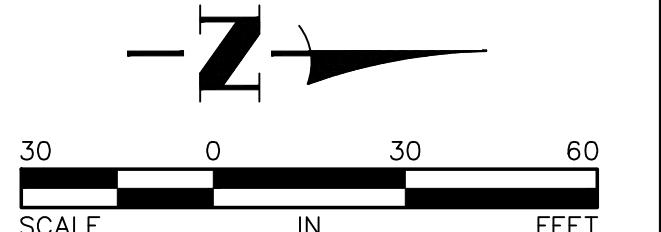

DATE	REVISION	DATE	REVISION
3/13/24	PLAN REVISIONS PER CITY REVIEW		
3/19/20	PLAN REVISIONS PER CLIENT REVIEW		

I hereby certify that this plan, specification, or report was prepared by me or under my direct supervision and that I am a duly Licensed Professional Engineer under the laws of the State of Minnesota.

Timothy A. Ebersole
 TIMOTHY A. EBERSOLE, P.E.
 Date 2/12/24 Lic. No. 43362

DESIGNED BY: TAE
 DRAWN BY: TAE
 CHECKED BY: CJJ

Hakanson Anderson
 Civil Engineers and Land Surveyors
 3601 Thurston Ave., Anoka, Minnesota 55303
 763-427-5860 FAX 763-427-0520
 www.hakanson-anderson.com

ST. KATHARINE DREXEL

UTILITY PLAN

CITY OF RAMSEY, MINNESOTA

SHEET C12 OF C13 SHEETS 4719.02

