

VOICE OF HOPE CHURCH

SITE DEVELOPMENT PROJECT

RAMSEY, MN



MINNESOTA

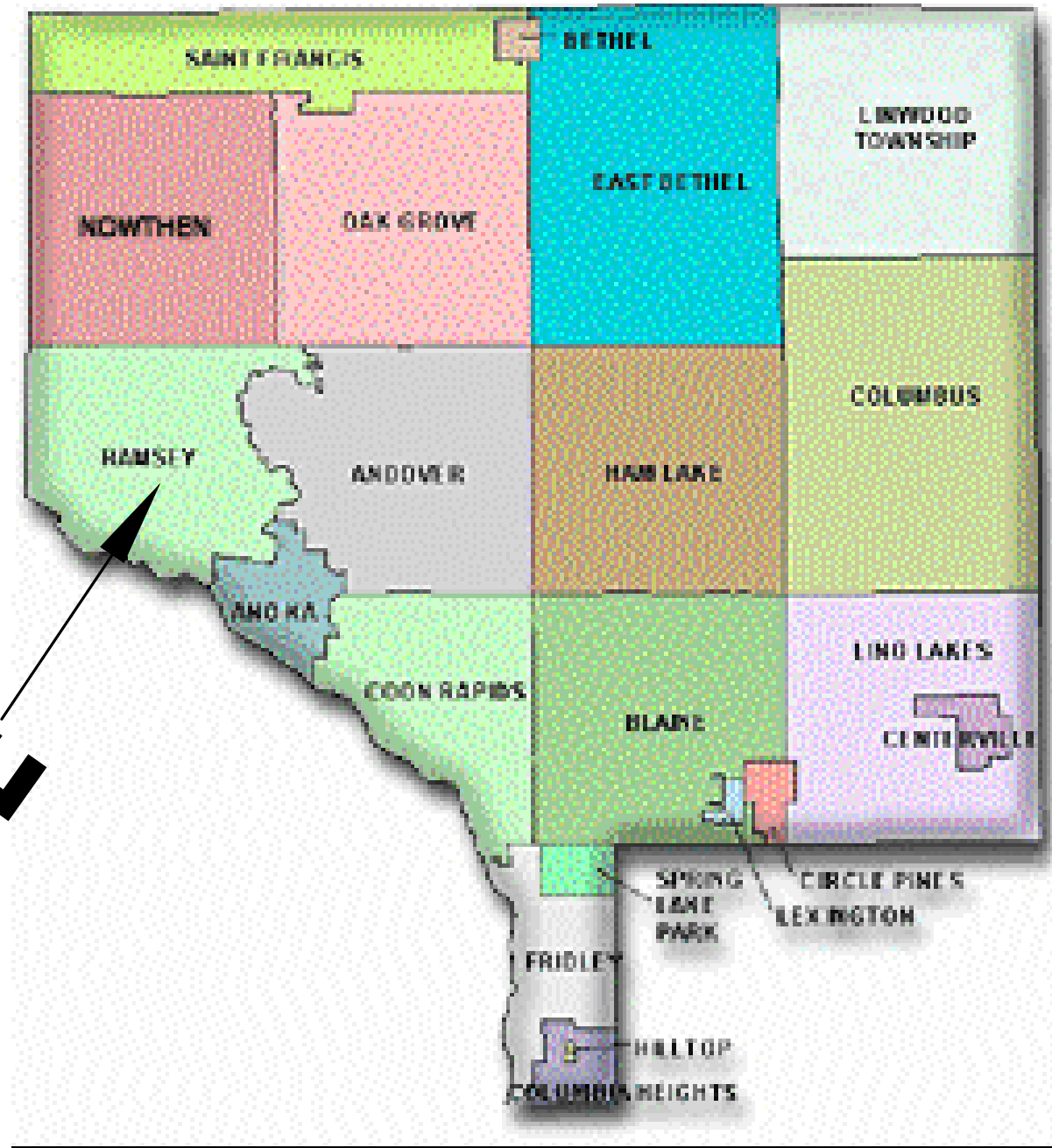

ANOKA COUNTY



RAMSEY, MN



PROJECT LOCATION

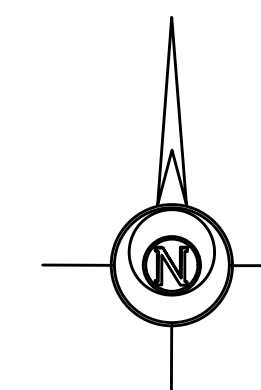

CLIENT:
VOICE OF HOPE CHURCH
 13850 Lincoln St NE
 Ham Lake, MN 55304
 Roman Andriychuk
 763-516-4206
 roman.atozcontract@gmail.com

SITE DEVELOPMENT PROJECT

**15620 Armstrong Blvd NW
 Ramsey, MN 55303**

PROJECT LOCATION PLAN

I hereby certify that this plan, specification, or report was prepared by me or under my direct supervision and that I am a duly Licensed Professional Engineer under the laws of the State of Minnesota.
S. D. Walker
 Date: 7/11/24 Reg. No. 24348
 PREPARED BY: **CIVIL ENGINEERING**
SITE DESIGN
 118 East Broadway St.
 PO Box 566
 Monticello, Mn 55362
 Phone: 763-314-0929
 www.civilso.com

REVISIONS	DATE	DRAWN BY	DESIGNED BY	CHECKED BY
06/18/24 GRADING MODIFICATIONS		SD	SD	SD
07/11/24 CITY COMMENTS				
HORIZONTAL SCALE 1 inch = _____ feet (FULL SIZE SHEET 22 X 30)				VERTICAL SCALE 1 inch = _____ feet

DATE	DRAWN BY	DESIGNED BY	CHECKED BY
06/14/24	SD	SD	SD

FILE NO. 00948

INDEX OF CIVIL SITE DRAWINGS:

- C0 PROJECT LOCATION PLAN
- C1.1-C1.2 PRELIMINARY PLAT & SITE DESIGN
- C2 GRADING & DRAINAGE PLAN
- C3 SANITARY & WATER UTILITY PLAN
- C4 STORM SEWER UTILITY PLAN
- C5 SWPPP
- C6 EXISTING CONDITIONS & REMOVAL PLAN
- C7.1-C7.3 DETAILS

CO

Project Location Plan

SURVEY DATA

SURVEY INFORMATION PROVIDED BY:
NORTHWESTERN SURVEYING & ENGINEERING, INC.
P.O. BOX 3067
BEMIDJI, MN 56601

DATED: OCT. 02, 2023

SITE BENCHMARK:
NE COR. SEC. 20
ELEV.=898.83

EXISTING LEGAL DESCRIPTION

The North 627.94 feet of the East 727.00 feet, as measured along the East and North lines respectively, thereof, of Section 20, Township 32, Range 25, Anoka County, Minnesota.

PARKING DATA:

REQUIRED PARKING PER CITY CODE:
ONE SPACE FOR EACH THREE SEATS OF DESIGN CAPACITY
DESIGN CAPACITY 500 SEATS / 3 = 167 STALLS
PROPOSED PARKING:
9'x20' STALLS = 109 INCLUDES 8 HANDICAP STALLS
9'x18' STALLS = 152
267 TOTAL

SITE DATA:

EXISTING ZONING: P1, PUBLIC/INSTITUTIONAL
TOTAL AREA: 456,508 SF = 10.48 ACRES
LOT 1, BLK 1 AREA: 388,991 SF = 8.93 ACRES
EXISTING IMPERVIOUS AREA: 941 SF
PROPOSED BUILDING AREA: 18,547 SF
PERCENT BUILDING FOOTPRINT COVERAGE: 4.77%
(18,547 / 388,991)
FLOOR AREA RATIO (ALL FLOORS): 0.0477
(18,547 / 388,991)
PROPOSED IMPERVIOUS AREA: 112,891 SF
(includes, proposed building & pavement areas)
PERCENT PROPOSED IMPERVIOUS AREA: 29.02%
(% of lot area; 112,891/388,991)
TOTAL PERVIOUS AREA: 276,100 SF
(landscape, turf areas)
PERCENT PERVIOUS AREA: 71.02%
(% of lot area; 276,100/388,991)
DISTURBANCE AREA: 5.8 AC

REFERENCE LOT REQUIREMENTS

ZONING: B1, B2, & B3
LOT DEPTH 150 FT
LOT WIDTH 100 FT
LOT AREA 0.50 AC. & B3=0.75 AC
SETBACKS: B1, B2, & B3
FRONT SETBACK 20 FT
SIDE SETBACK (INTERIOR) 10 FT
SIDE SETBACK (TO ROW) 20 FT
REAR SETBACK (INTERIOR) 35 FT
REAR SETBACK (TO ROW) 20 FT
SETBACK TO RESIDENTIAL DISTRICT 60 FT
SETBACK TO WETLANDS 16.5 FT
ZONING: RR
LOT DEPTH 200 FT
LOT WIDTH 200 FT
LOT AREA 2.50 AC
MIN. LOT FRONTAGE ON A PUBLIC STREET 60 FT
SETBACKS: RR
FRONT SETBACK 40 FT
SETBACK FROM ARTERIAL ROADWAYS 60 FT
SIDE SETBACK (INTERIOR) 40 FT
SIDE SETBACK (TO ROW) 40 FT
REAR SETBACK 40 FT
SETBACK TO WETLANDS 16.5 FT

KEY NOTES:

- 1 BITUMINOUS PAVEMENT; SEE SECTION ON DETAIL SHEET
- 2 3" VALLEY GUTTER (SEE DETAIL)
- 3 CONCRETE PAVEMENT HEAVY DUTY; 4,500 PSI MIX; SEE SECTION ON DETAIL SHEET
- 4 CONCRETE PAVEMENT LIGHT DUTY; 4,500 PSI MIX; SEE SECTION ON DETAIL SHEET
- 5 PAINT 4" SOLID STRIPE - WHITE LATEX PAINT
- 6 SAWCUT AND REMOVE EXISTING PAVEMENT SURFACE FOR CLEAN EDGE (REPLACE PAVEMENT SURFACE IN-KIND)
- 7 EXISTING PAVEMENT TO REMAIN
- 8 EXISTING UTILITIES OR SITE FEATURE TO REMAIN IN PLACE. CONTRACTOR TO PROTECT
- 9 CONTRACTOR TO COORDINATE RELOCATION OF EXISTING UTILITIES TO ACCOMMODATE CULVERT, DRIVE, AND GRADING
- 10 PERVIOUS AREA
- 11 PED RAMP TO COMPLY WITH AMERICANS WITH DISABILITIES ACT (ADA) REQUIREMENTS. REFERENCE MNDOT STANDARD PLAN 5-297.250 INCLUDING CONTRASTING DETECTABLE WARNING DEVICES. DEPRESS BACK OF CURB AT RAMP
- 12 CONTRACTOR TO RESTORE SIDEWALK TO MATCH EXISTING PAVEMENT SECTION.
- 13 PAINT INTERNATIONAL SYMBOL OF ACCESSIBILITY - WHITE LATEX PAINT
- 14 ACCESSIBLE PARKING SIGN (MNDOT NOS. R7-8A & R7-8B). CENTER SIGN ON PARKING STALL. LOCATION PER GENERAL CONTRACTOR. MOUNT ON STEEL CHANNEL POST. SIGN HEIGHT PER MN ADA REQUIREMENTS.
- 15 NO PARKING SIGN (MNDOT # R8-3). CENTER SIGN ON ADA ACCESS AISLE. LOCATION PER GENERAL CONTRACTOR. MOUNT ON STEEL CHANNEL POST. SIGN HEIGHT PER MN ADA REQUIREMENTS.
- 16 B612 (6") CONCRETE CURB & GUTTER MIX 3F32 FOR MACHINE PLACEMENT (MNDOT 2461) MIX 3F52 FOR MANUAL PLACEMENT (MNDOT 2461) DEPRESS BACK OF CURB AT ACCESS DRIVE
- 17 B612 (6") CONCRETE OUTFLOW CURB & GUTTER. (TIP-OUT FLOWLINE) MIX 3F32 FOR MACHINE PLACEMENT (MNDOT 2461) MIX 3F52 FOR MANUAL PLACEMENT (MNDOT 2461)
- 18 TRASH ENCLOSURE (SEE ARCHITECTURAL PLANS)
- 19 CONCRETE PAVEMENT SECTION PER STRUCTURAL DESIGN PLANS
- 20 PROPOSED WETLAND BUFFER / CONSERVATION EASEMENT SIGN
- 21 FIRE DEPARTMENT CONNECTION ON BUILDING WALL FOR FIRE SUPPRESSION SYSTEM.
- 22 LIGHT POLE. REFER TO LIGHTING AND PHOTOMETRIC PLAN FOR LOCATIONS AND SPECIFICATIONS
- 23 SEPTIC FIELD PROTECTION FENCE
- 24 ACCESS CONTROL
- 25 DIRECTIONAL TRAFFIC SIGN ON STEEL CHANNEL POST (STOP SIGN)
- 26 9 FT CURB-CUT (SEE DETAIL)

INDEX OF CIVIL SITE DRAWINGS:

C0	PROJECT LOCATION PLAN
C1.1-C1.2	PRELIMINARY PLAT & SITE DESIGN
C2	GRADING & DRAINAGE PLAN
C3	SANITARY & WATER UTILITY PLAN
C4	STORM SEWER UTILITY PLAN
C5	SWPPP
C6	EXISTING CONDITIONS & REMOVAL PLAN
C7.1-C7.3	DETAILS

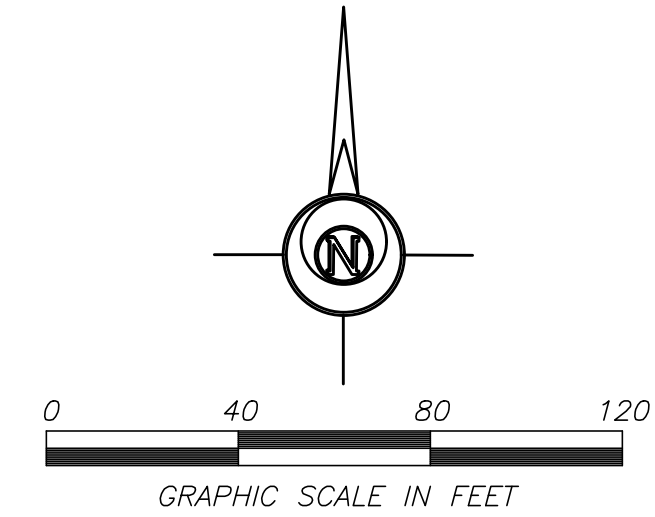

LEGEND:

- 908 Existing Contours
- >> Existing Storm Sewer
- x 908.2 Existing Spot Elevation
- <<< Existing Storm Sewer
- < Existing Sanitary Sewer
- W—W Existing Watermain Sewer
- T—T Existing Underground Telephone
- E— Existing Underground Electric
- Existing Tree Line
- Existing Easement Line
- Existing R/W Line
- Existing Boundary Line
- Existing Catch Basin
- Existing Manhole
- Existing Hydrant
- Existing Flared End Section
- Proposed Curb And Gutter Standard
- Proposed Curb And Gutter Tip-out
- Proposed Concrete Light Duty Sidewalk
- Propose Lot Line
- Proposed Concrete Heavy Duty
- Proposed Bituminous Pavement
- Concrete Pavement Section Per Structural Design Plans
- Septic Drainfield Protection fence
- Access Control

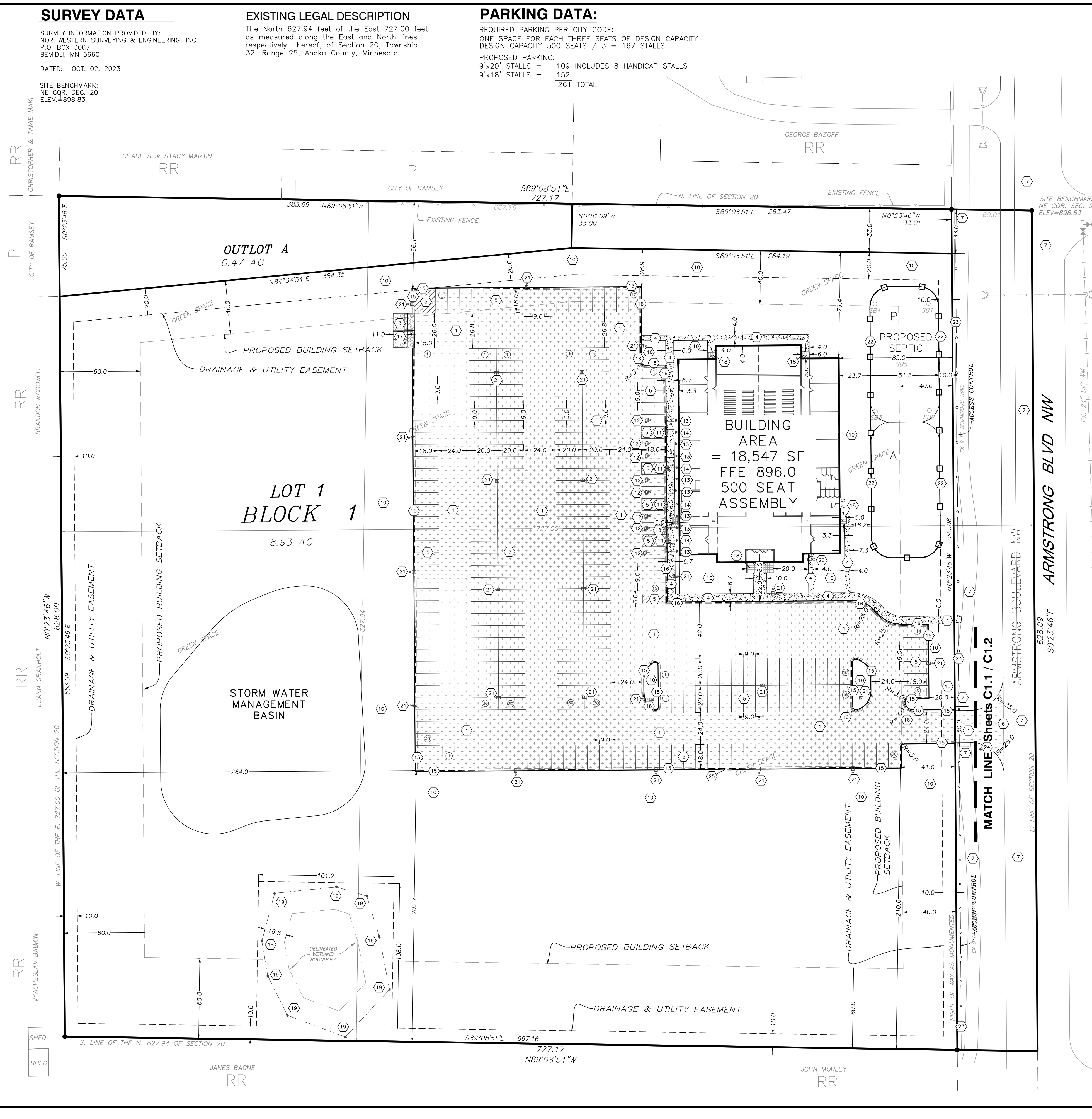

CLIENT:
VOICE OF HOPE CHURCH
13850 Lincoln St NE
Ham Lake, MN 55304
Roman Andrychuk
763-516-4206
roman.atozcontract@gmail.com

SITE DEVELOPMENT PROJECT
15620 Armstrong Blvd NW Ramsey, MN 55309
PRELIMINARY PLAT OF VOICE OF HOPE CHURCH & SITE DESIGN

I hereby certify that this plan, specification, or report was prepared by me or under my direct supervision and that I am a duly Licensed Professional Engineer under the laws of the State of Minnesota.
Sart Dalka
Date: 7/11/24 Reg. No. 24348
PREPARED BY: **CIVIL ENGINEERING SITE DESIGN**
116 East Broadway St.
PO Box 566
Monticello, Mn 55362
Phone: 763-314-0929
www.civilesa.com

REVISIONS	DATE	DESCRIPTION
06/18/24	06/18/24	GRADING MODIFICATIONS
07/11/24	07/11/24	CITY COMMENTS

DATE	06/14/24
DRAWN BY	SD
DESIGNED BY	SD
CHECKED BY	SD

FILE NO. 00948

C1.1
Preliminary Plat & Site Design

CLIENT:
VOICE OF HOPE CHURCH
 13850 Lincoln St NE
 Ham Lake, MN 55304
 Roman Andriychuk
 763-516-4206
 roman.atozcontract@gmail.com

SITE DEVELOPMENT PROJECT
15620 Armstrong Blvd NW Ramsey, MN 55303
RIGHT TURN LANE SITE DESIGN

I hereby certify that this plan, specification, or report was prepared by me or under my direct supervision and that I am a duly Licensed Professional Engineer under the laws of the State of Minnesota.
 Date: 7/11/24 Reg. No. 24348
 PREPARED BY: CIVIL ENGINEERING SITE DESIGN
 118 East Broadway St.
 Monticello, Mn 55362
 Phone: 763-314-0929
 www.civilres.com

REVISIONS	DATE	DESCRIPTION	HORIZONTAL SCALE	VERTICAL SCALE
06/18/24 GRADING MODIFICATIONS			1 inch = 10 feet	1 inch = 10 feet
07/11/24 CITY COMMENTS			1 inch = 10 feet	1 inch = 10 feet

DATE	DRAWN BY	DESIGNED BY	CHECKED BY
06/14/24	SD	SD	SD

FILE NO. 00948

C1.2
 Right Turn Lane Site Design

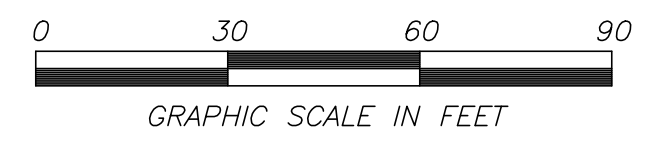
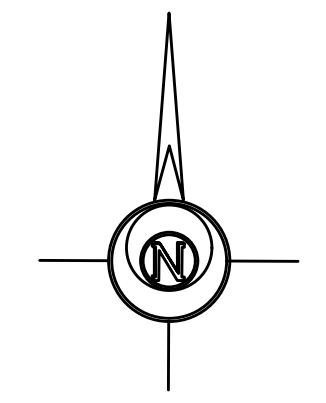

- LEGEND:**
- 908 Existing Contours
 - >> Existing Storm Sewer
 - x 908.2 Existing Spot Elevation
 - << Existing Storm Sewer
 - < Existing Sanitary Sewer
 - WM WM Existing Watermain Sewer
 - T-T- Existing Underground Telephone
 - E- Existing Underground Electric
 - Existing Tree Line
 - Existing Easement Line
 - Existing R/w Line
 - Existing Boundary Line
 - Existing Catch Basin
 - Existing Manhole
 - Existing Hydrant
 - Existing Flared End Section
 - Propose Lot Line

SURVEY DATA

SURVEY INFORMATION PROVIDED BY:
 NORTHWESTERN SURVEYING & ENGINEERING, INC.
 P.O. BOX 3067
 BEMIDJI, MN 56601
 DATED: OCT. 02, 2023
 SITE BENCHMARK:
 NE COR. DEC. 20
 ELEV.=898.83

EXISTING LEGAL DESCRIPTION

The North 627.94 feet of the East 727.00 feet, as measured along the East and North lines respectively, thereof, of Section 20, Township 32, Range 25, Anoka County, Minnesota.

INDEX OF CIVIL SITE DRAWINGS:

- C0 PROJECT LOCATION PLAN
- C1.1-C1.2 PRELIMINARY PLAT & SITE DESIGN
- C2 GRADING & DRAINAGE PLAN
- C3 SANITARY & WATER UTILITY PLAN
- C4 STORM SEWER UTILITY PLAN
- C5 SWPPP
- C6 EXISTING CONDITIONS & REMOVAL PLAN
- C7.1-C7.3 DETAILS

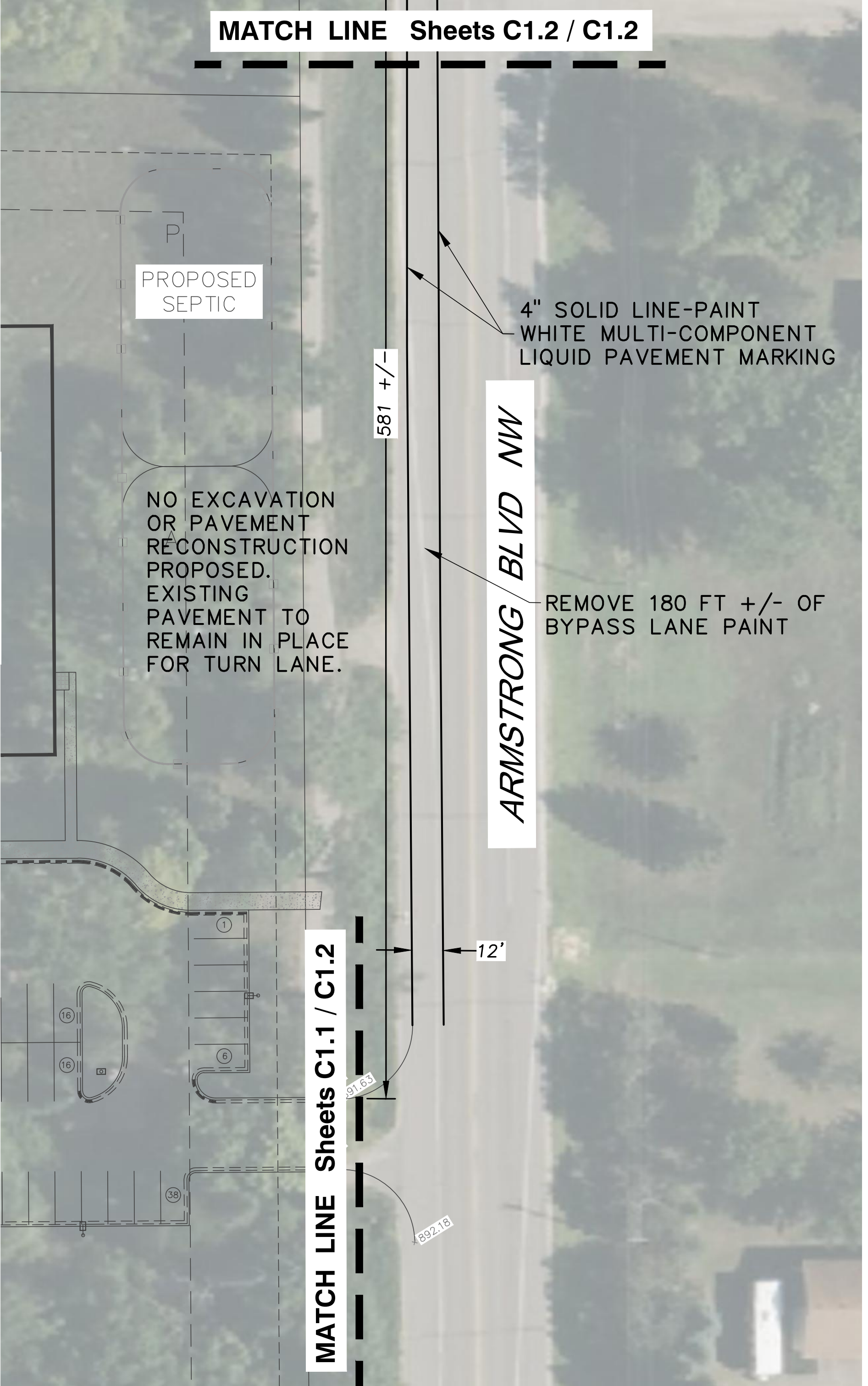
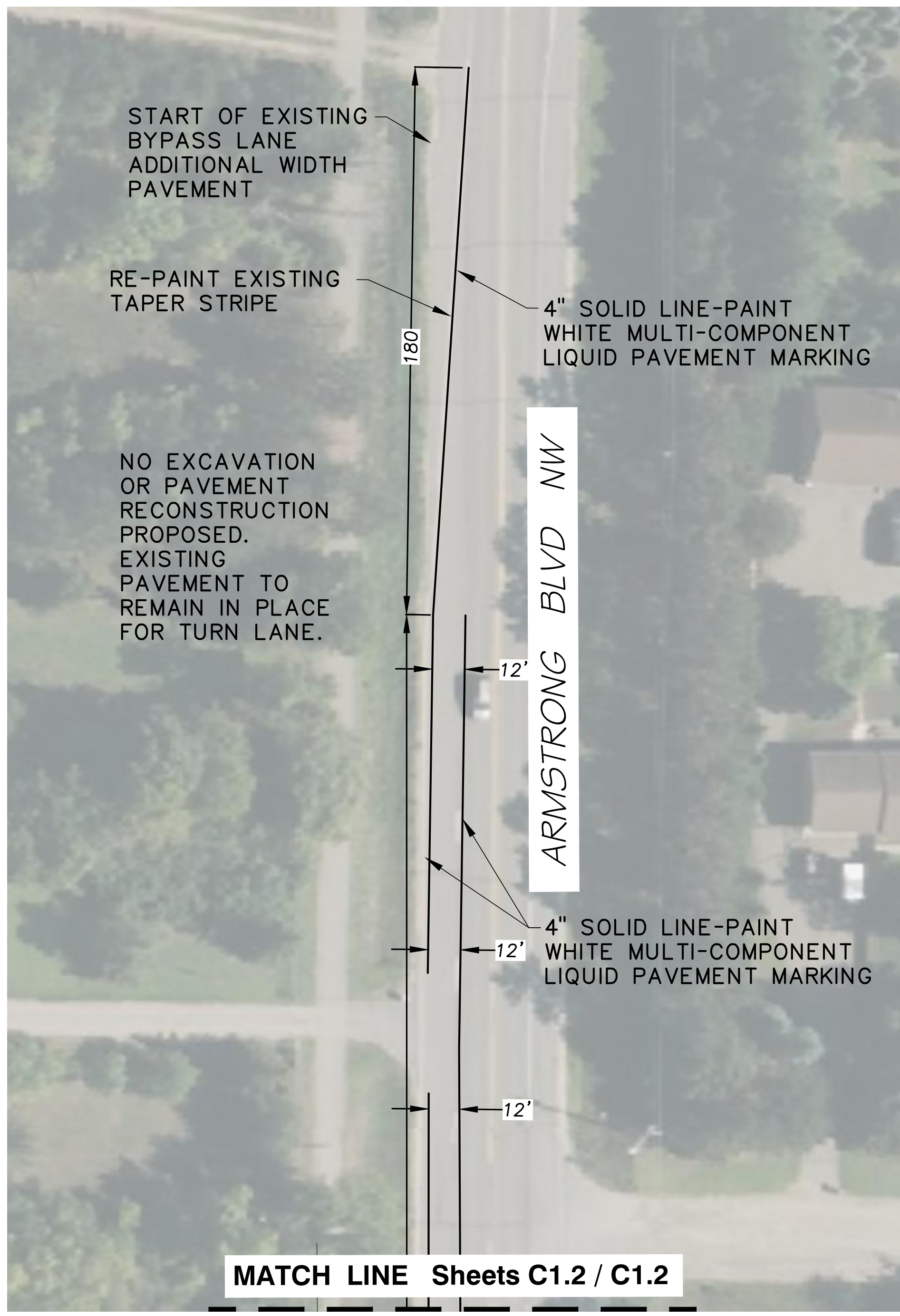

DATE 06/14/24 DRAWN BY SD DESIGNED BY SD CHECKED BY SD

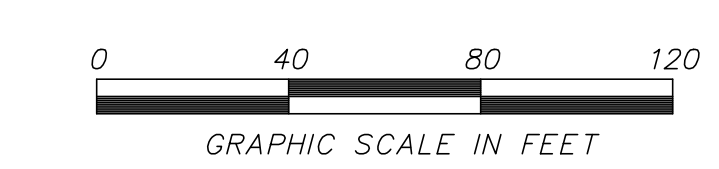
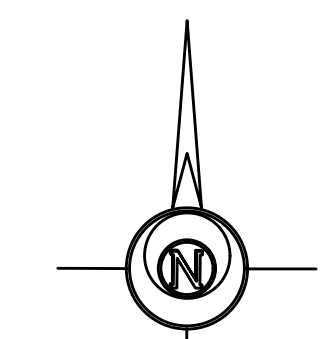
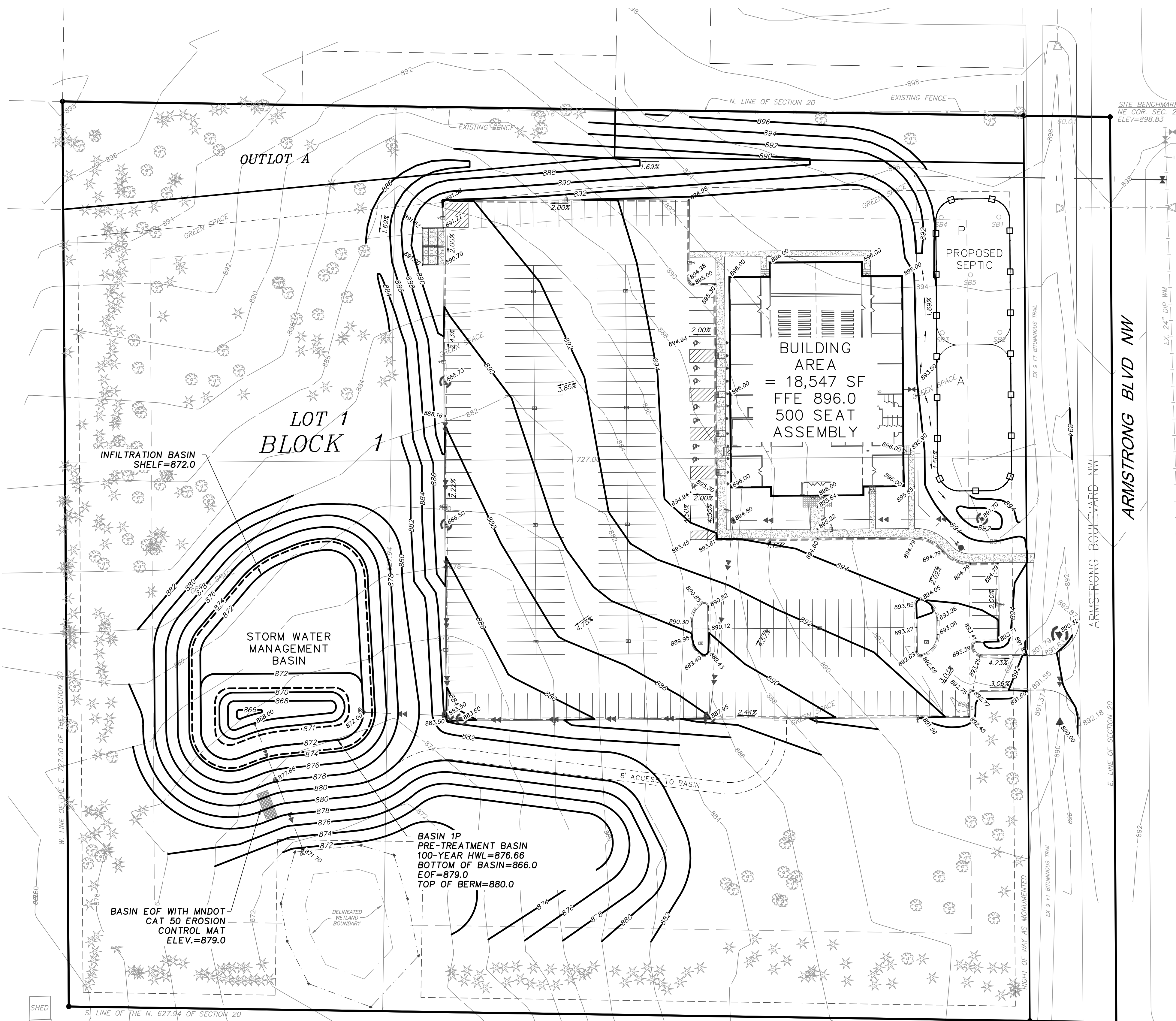

- LEGEND:**
- 908 — Existing Contours
 - - - Existing Storm Sewer
 - x 908.2 Existing Spot Elevation
 - 908 — Proposed Contours
 - - - Proposed Storm Sewer
 - x ###.## Proposed Spot Elevation
 - #-% — Flow Direction
 - Proposed Storm Sewer Inlet Protection
 - Septic Drainfield Protection fence

SURVEY DATA

SURVEY INFORMATION PROVIDED BY:
NORTHWESTERN SURVEYING & ENGINEERING, INC.
P.O. BOX 3067
BEMIDJI, MN 56601

DATED: OCT. 02, 2023

SITE BENCHMARK:
NE COR. SEC. 20
ELEV.=898.83

GENERAL GRADING NOTES:

1. Specifications applicable for this project: Current standard specifications for City of Ramsey, MN, and the latest Minnesota Department of Transportation Specifications for Highway Construction and all NPDES requirements except where modified by these contract documents.
2. OSHA requirements shall be followed for all work on this project.
3. The Contractor shall notify "Gopher State One Call" 48 hours prior to any excavation (1-800-252-1166.)
4. The Grading Contractor shall verify all locations and elevations of underground utilities with utility companies prior to any construction, and immediately notify the Engineer of any conflicts.
5. Erosion Control shall be constructed, as applicable, as sequenced below:
 - A) Silt Fence.
 - B) Rock Construction Entrance.
 - C) Demolition
 - D) Common excavation (grading).
 - E) Seed and mulch or sod (See notes on Landscape plan).
6. Final Plat shall govern for easements and lot dimensions.
7. Any erosion control items necessary to protect adjacent properties shall be constructed by the Grading Contractor.
8. Erosion control maintenance shall be performed by the Grading Contractor, and removed as per the Contract Documents or as directed by the Engineer, followed by all necessary restoration of disturbed area. This work shall be incidental to the grading contract.
9. The Grading Contractor shall schedule the soils engineer to facilitate certification of all controlled fills in a timely fashion. Density tests shall meet the following:
 - A) Within the upper 3' of streets, the Grading Contractor shall utilize approved soils that are within 1% of the optimum moisture content as defined by the Standard Proctor Test—ASTM: D-698 with compaction meeting 100% Standard Proctor Density and not exceeding this compaction by more than 1%. Below the upper 3', compaction shall meet 95% Standard Proctor Density, and be within 3% of the optimum moisture content. Grading tolerances shall be 0.1'.
 - B) Grading tolerances for the remainder of the site shall be 0.25'.
10. All areas of unsuitable soils found in the pad described above that cannot be corrected shall be located in the field by the Grading Contractor. The Grading Contractor shall immediately notify the Engineer of these areas and provide information as to their size and location.
11. The Grading contractor shall provide positive drainage on the site at all times.
12. The Grading Contractor shall keep public streets and travel ways clear of soil and debris. Daily cleaning at the construction entrance shall be performed, especially at the end of each day's work.
13. All silt fence shall be removed at project completion.
14. All erosion control best management practices shall be per City standards.

INDEX OF CIVIL SITE DRAWINGS:

C0	PROJECT LOCATION PLAN
C1.1-C1.2	PRELIMINARY PLAT & SITE DESIGN
C2	GRADING & DRAINAGE PLAN
C3	SANITARY & WATER UTILITY PLAN
C4	STORM SEWER UTILITY PLAN
C5	SWPPP
C6	EXISTING CONDITIONS & REMOVAL PLAN
C7.1-C7.3	DETAILS

CLIENT:
VOICE OF HOPE CHURCH
13850 Lincoln St NE
Ham Lake, MN 55304

Roman Andriychuk
763-516-4206
roman.atozcontract@gmail.com

SITE DEVELOPMENT PROJECT

**15620 Armstrong Blvd NW
Ramsey, MN 55303**

GRADING & DRAINAGE PLAN

I hereby certify that this plan, specification, or report was prepared by me or under my direct supervision and that I am a duly Licensed Professional Engineer under the laws of the State of Minnesota.

S. D. Walker
Date: 7/11/24 Reg. No. 24348

PREPARED BY: **CIVIL ENGINEERING SITE DESIGN**
116 East Broadway St.
Monticello, Mn 55362
Phone: 763-314-0929
www.civiles.com

REVISIONS	DATE	BY	DESCRIPTION
	06/18/24	SD	GRADING MODIFICATIONS
	07/11/24	SD	CITY COMMENTS

HORIZONTAL SCALE	1 inch = 30 feet (FULL SIZE SHEET 22 X 30)
VERTICAL SCALE	1 inch = 4 feet

DATE	06/14/24
DRAWN BY	SD
DESIGNED BY	SD
CHECKED BY	SD

FILE NO. 00948

C2

Grading & Drainage Plan

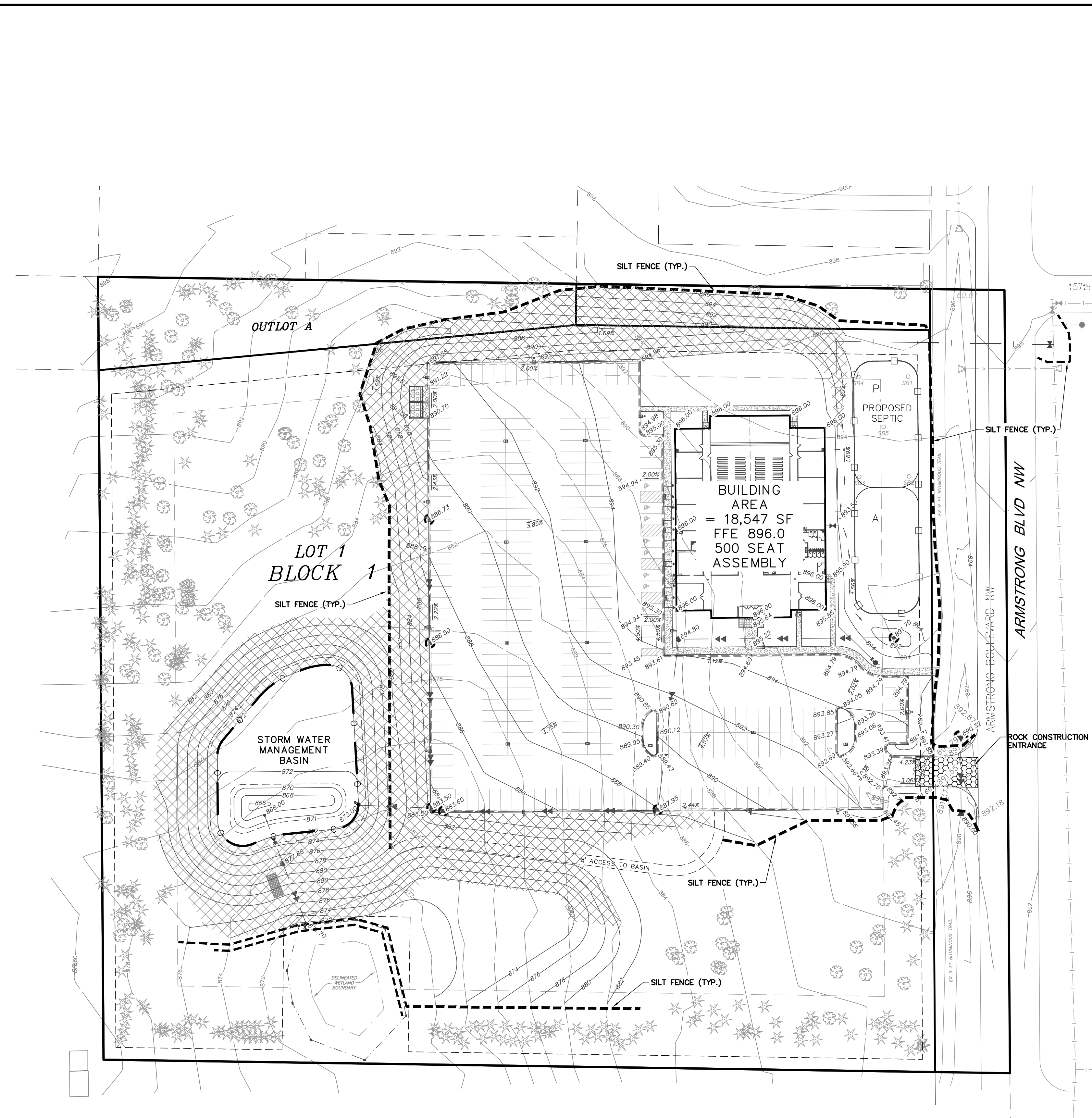

SWPPP NARRATIVE

This commercial site project construction will consist of site clearing, grading, utilities, and street. Construction is planned for 2024-2025.

First, perimeter silt fence and rock construction entrance shall be installed. Then site work shall commence. The contractor shall dispose all debris off-site within 24 hours. Then the site can be graded, utilities installed, including gas, electric, and communication utilities, buildings constructed, curbing and pavements installed, final grade tolerance, and landscape final stabilization. Once final grade is established and certified, the site shall be stabilized with seed and mulch or sod. Once vegetation is established, temporary erosion control measures shall be removed.

POLLUTION PREVENTION NOTES

Solid waste: collected sediment, asphalt and concrete millings, floating debris, paper, plastic, fabric, construction debris and other wastes must be disposed of properly off-site and must comply with MPCA requirements.

Hazardous materials: oils, gasoline, paint, and any hazardous substance must be properly stored, including secondary containment, to prevent spills, leaks or other discharge. Restricted access to storage areas must be provided to prevent vandalism. Storage and disposal must be in compliance with MPCA regulations.

External washing of trucks or other construction vehicles is not allowed on site. No engine degreasing is allowed on site. No concrete washouts are allowed on site.

Concrete truck washout is not to be allowed on site unless washout waste is contained with no discharge to ground surface or site drainage facilities. Containment systems are to be located a minimum 50 feet away from drainage facilities and watercourses. Containment systems shall have an impermeable liner. Containment system shall be clearly marked with signage.

All sanitary waste must be collected from portable toilet units on site by a licensed waste management contractor. The units must be secured and shall be maintained on a regular basis as needed to prevent overflowing.

DESIGN CALCULATIONS

Design calculations, including soil types are on file with: Civil Engineering Site Design

SWPPP Designer: Scott Dahlke (Expires 2025)

EROSION CONTROL NOTES

- All devices necessary to control erosion and sediment (i.e. perimeter silt fence, rock construction entrances, swales, ponds, berms, etc.) shall be installed prior to any other construction operations.
- After completion of final grading, exposed soils must be permanently stabilized within 14 days. Stabilization shall consist of disc-and-buried seed & mulch, HECIP with fiber reinforced matrix, erosion blanket with seed, or sod.
- The site must be kept in a well drained condition at all times. The contractor shall be responsible for temporary ditches, or other means necessary to ensure proper drainage. The building pad must be provided with a positive outflow. This work shall be incidental to the grading contract.
- Entering/exiting of the site shall occur only at rock construction entrance to reduce tracking of dirt onto paved streets. Sediment tracked onto streets during working hours must be reclaimed via street scraping and sweeping at the end of each working day.
- Stormwater discharge pipe outlet energy dissipation shall be provided by rip-rap with size, quantity, and placement in accordance with City standards. Rip-rap installation shall be within 24 hours of pipe installation.
- Install silt fence around all temporary inactive stockpiles which are not place within existing silt fence area or other perimeter erosion controls.
- Stabilization of temporary or permanent drainage ditches that drain water from the construction site must be initiated within 24 hours of connecting the drainage ditch to any storm water conveyance system and must be completed using erosion blanket.
- Sufficient personnel, equipment, and materials shall be mobilized within 24 hours of written order (i.e. email) by the owner or owners representative to conduct corrective work and install temporary erosion control work in the case of an emergency.

EROSION CONTROL INSTALLATION SCHEDULE

- Silt fence shall be installed or restored prior to any construction. Silt fence shall be located as shown to intercept runoff. The area located beyond the perimeter silt fence shall not be disturbed during construction.
- Rock Construction Entrance shall be installed prior to grading operations.
- All storm sewer inlets shall have inlet protection inserts installed. Inserts shall be "Road Rain-Top" or "Road Drain-Curb & Gutter" inlet protection devices as manufactured by WIMCO (or approved equal) and installed per manufacturer's recommendations.
- All erosion control installations shall remain in place and be maintained in good condition by the contractor until the site has been re-vegetated, at which time it shall be removed by the contractor. For proposed paved surface areas, the contractor may remove necessary silt fencing to construct roadway, while maintaining adequate erosion control in adjacent areas.
- Sufficient topsoil shall be stockpiled to allow for the replacement of 6" topsoil for disturbed areas to be re-vegetated.
- The contractor shall schedule site grading, utility installation and roadway construction so that the general site can be mulched and re-seeded soon after disturbance. Areas that will not be subject to construction traffic for 14 days shall be seeded and mulched or sodded within 14 days of final grading.

EROSION CONTROL MAINTENANCE SCHEDULE

- Erosion control measures shall be inspected by the contractor's representative and maintained by the contractor every Friday and within 24 hours after any rainfall event larger than 1/2" until the project is completed. Maintenance requirements are as follows: silt fence - 1/3 height of fence or damaged, remove sediment and/or repair fence within 24 hours; rock entrance - refresh as necessary to conform to detail; inlet protection inserts - remove sediment after each rain event, clean or replace filter when clogged; surface water - drain and stabilize, within 7 days of discovery and street sweeping - remove all sediment tracked onto paved surfaces within 24 hours or as directed by City Engineer.
- Replacement - Fabric shall be replaced promptly when it decomposes or becomes ineffective before the barrier is no longer necessary.
- Any sediment remaining in place after silt fence is no longer required shall be dressed to conform with the existing grade, prepared, and seeded with appropriate seed mix, as directed by the engineer.
- Removal of the silt fence- Silt fences shall be removed when they have served their useful purpose, but not before the upward sloping area has been permanently stabilized.

VEGETATION GROUND COVER SCHEDULE

- Stabilization of all exposed soil areas must be initiated immediately but in no case completed later than fourteen (14) days after the construction activity in that portion of the site has temporarily or permanently ceased. Seeding and mulching shall conform to the latest NPDES requirements for installation schedule with regards to grading.
- Permanent turf ground cover shall include all disturbed areas be covered with a minimum 6" topsoil. Turf seed to be MnDOT mix 25-11 applied at 59 lbs/ac with MnDOT Type 3 mulch to be applied at 2 tons/ac and disc anchored in areas not covered by sod or erosion blanket. Infiltration basin seed to be 33-261 applied at 35 lbs/ac with bottom of basin mulched with clean grain straw (MnDOT Type 3) applied at 2 tons/ac. Do not seed below open water in wet pond pre-treatment area. Seeding and mulching shall conform to the latest NPDES requirements for installation schedule with regards to grading.
- Temporary ground cover to be MnDOT seed mix 22-111 shall be applied at 31 lbs/ac, or equivalent as approved by City. MnDOT Type 1 mulch shall be applied at 2 tons/ac and disc anchored in areas not covered by sod or erosion blanket.
- Fertilizer for turf shall be MnDOT Type 3 22-5-10 and applied at 350 lb/ac. Disc fertilizer into top 3" of soil. Fertilizer. Specification reference is MnDOT 2574. Dormant seed mix shall be used after November 1 or when temperatures do not exceed 40° F, using same rates specified above. No seed shall be placed on snow or ice greater than 2" in depth.
- Any seeded areas that do not become established with vegetation shall be re-seeded at Contractor's expense.
- Erosion blanket shall be installed in seed areas with ground surface slopes of 4H:1V or steeper.

RESponsible Party

Contact information for the responsible party for erosion control is:

Owner: Roman Andriychuk
13850 Lincoln Street NE
Ham Lake, MN 55304
763-516-4206

Contractor: To be Determined

Manager: To be Determined

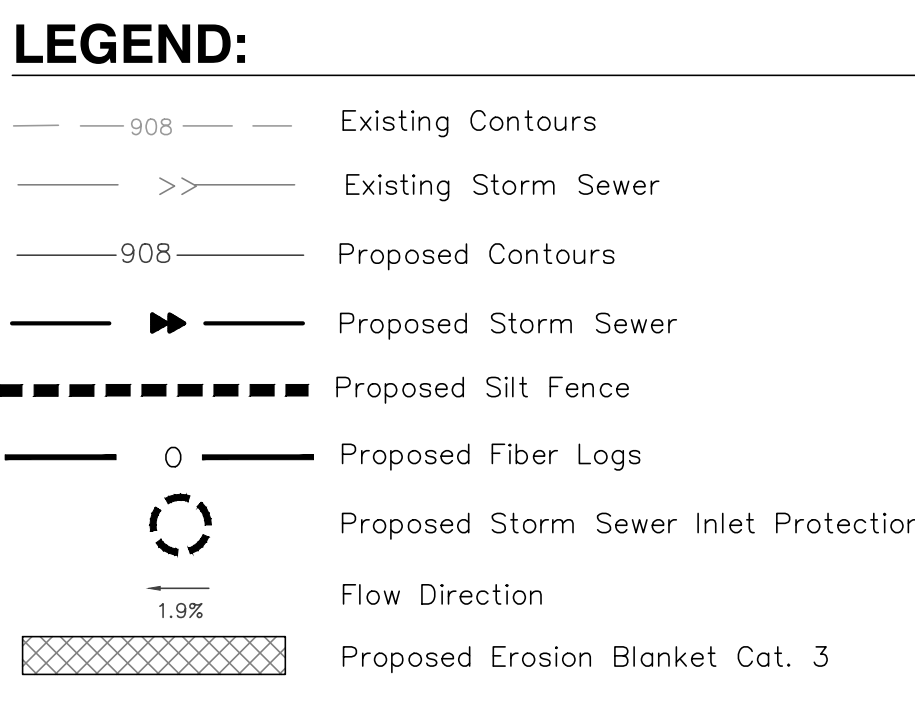
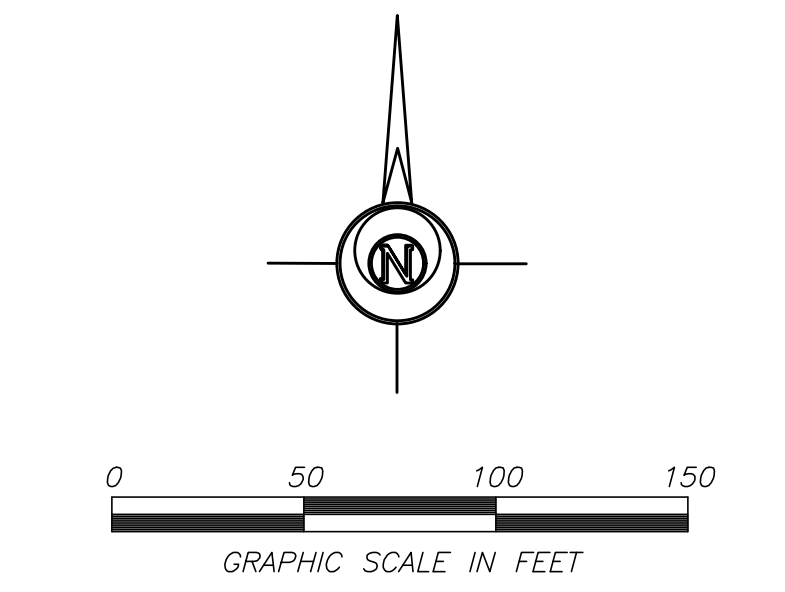

EXISTING LEGAL DESCRIPTION

The North 627.94 feet of the East 727.00 feet, as measured along the East and North lines respectively, thereof, of Section 20, Township 32, Range 25, Anoka County, Minnesota.

SITE DATA

TOTAL AREA = 456,508 SF = 10.48 AC
EXISTING TOTAL IMPERVIOUS AREA: 941 SF
PROPOSED TOTAL IMPERVIOUS AREA: 112,891 SF (2.59 AC)
PERCENT TOTAL IMPERVIOUS AREA: 24.7%
(112,891 SF / 456,508 SF)
AREA OF DISTURBANCE: 5.8 AC

EROSION CONTROL QUANTITIES:

ITEM:	QUANTITY	UNIT
ROCK ENTRANCE	1	EA
SILT FENCE	1	LF
FIBER LOGS	2,210	LF
INLET PROTECTION	450	EA
STRAW MULCH TYPE 3	7	AC
EROSION BLANKET CAT. 3	7,844	SY

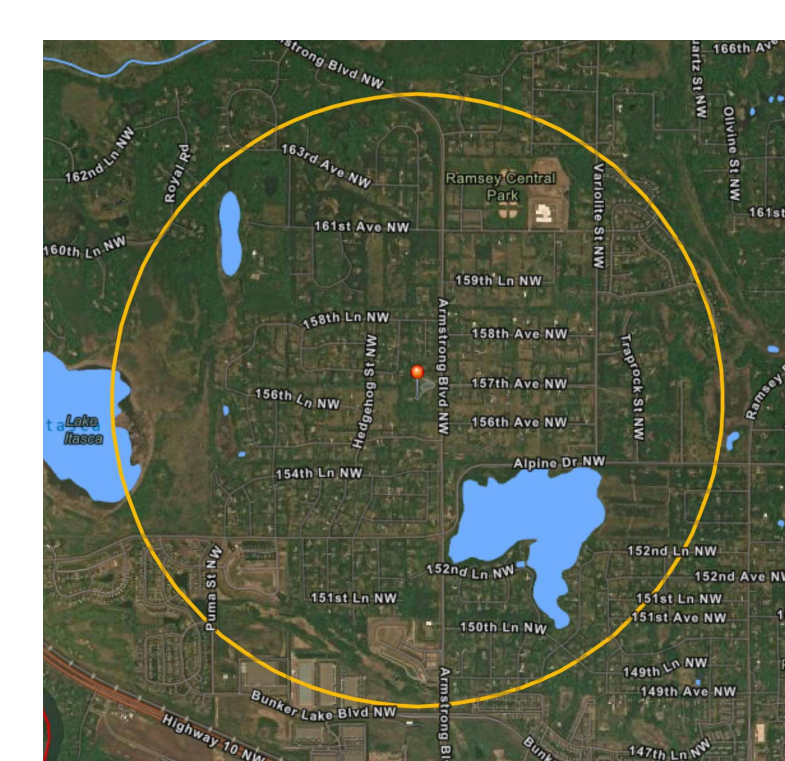

NO IMPAIRED WATER WITHIN 1 MILE RADIUS OF PROJECT:

CITY SPECIFIC REQUIREMENT NOTES

- A sweeper must be available to the site to remove tracking on public streets within 3 hours notice from the City.
- Send weekly and 1/2 inch event reports to the city inspector.

INFILTRATION BASIN NOTES

- Infiltration area shall be staked off during construction to restrict heavy equipment traffic from compacting native soils.
- Install appropriate temporary erosion control devices to prevent sediment from entering the practice during construction.
- Grading of the infiltration basin shall be accomplished using low impact earth-moving equipment to prevent compaction of the underlying soils. Small tracked dozers and skid-steers with runner tracks are recommended.
- In the event that sediment is introduced into the BMP during or immediately following excavation, this material will need to be removed from the basin prior to initiating the next step in the construction process.
- Install sediment control ground basin after completion of basin grading.
- Seeding and installation of erosion control shall be completed within 48 hours of final grading of basin.

LOCATION OF SWPPP REQUIREMENTS IN PLANS

DESCRIPTION	LOCATION
STANDARD BMP DETAILS	DETAILS ON SHEET C7.1-7.3
STORMWATER CALCULATIONS	STORM SEWER REPORT
SITE MAP	STORM SEWER REPORT
DRAINAGE ROUTING	GRADING PLAN SHEET C2
SOILS DATA	GEO TECHNICAL REPORT

REVISIONS

DATE	BY	SD	DESCRIPTION
06/18/24	SD		GRADING MODIFICATIONS
07/11/24	SD		CITY COMMENTS

CLIENT:
VOICE OF HOPE CHURCH
13850 Lincoln St NE
Ham Lake, MN 55304

Roman Andriychuk
763-516-4206
roman.atozcontract@gmail.com

SITE DEVELOPMENT PROJECT
15620 Armstrong Blvd NW
Ramsey, MN 55303
SWPPP

I hereby certify that this plan, specification, or report was prepared by me or under my direct supervision and that I am a duly Licensed Professional Engineer under the laws of the State of Minnesota.
Scott Dahlke
Date: 7/11/24 Reg. No. 24348
PREPARED BY: CIVIL ENGINEERING SITE DESIGN
115 East Broadway St.
PO Box 566
Monticello, Mn 55362
Phone: 763-314-0929
www.civilesa.com

DATE 06/14/24
DRAWN BY SD
DESIGNED BY SD
CHECKED BY SD

FILE NO. 00948

INDEX OF CIVIL SITE DRAWINGS:

C0	PROJECT LOCATION PLAN
C1.1-C1.2	PRELIMINARY PLAT & SITE DESIGN
C2	GRADING & DRAINAGE PLAN
C3	SANITARY & WATER UTILITY PLAN
C4	STORM SEWER UTILITY PLAN
C5	SWPPP
C6	EXISTING CONDITIONS & REMOVAL PLAN
C7.1-C7.3	DETAILS

C5
SWPPP

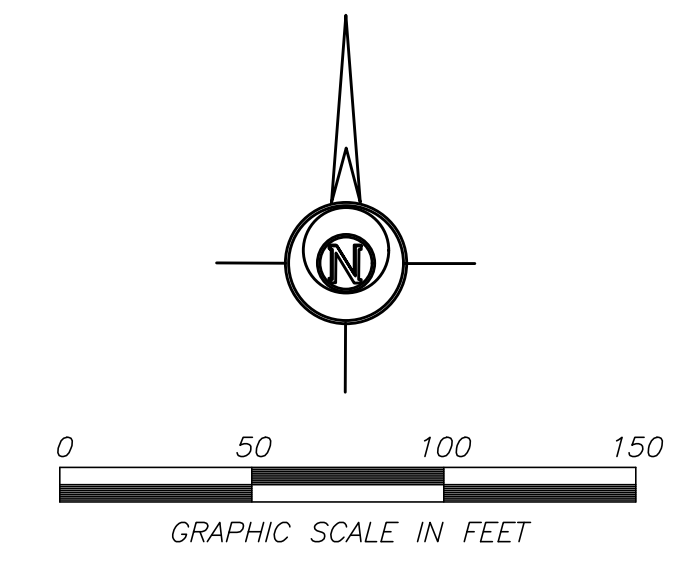
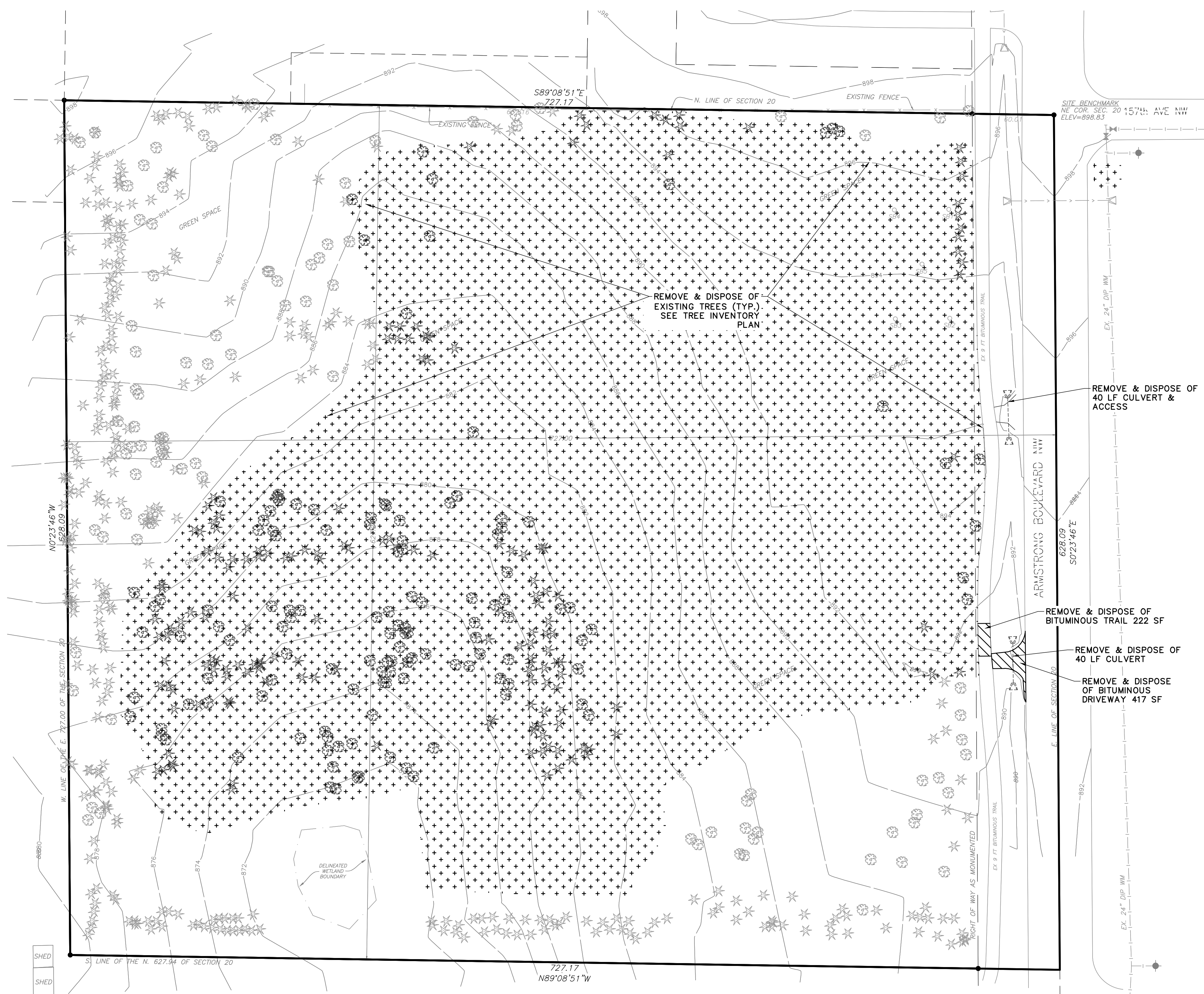

- LEGEND:**
- Existing Contours
 - Existing Sanitary Sewer
 - Existing Water Main
 - Existing Storm Sewer
 - Existing Trees
 - Existing Bndy Line
 - PROPOSED DEMOLITION & REMOVAL AREA
 - PROPOSED TREE REMOVAL & DISTURBED AREA

EXISTING LEGAL DESCRIPTION
 The North 627.94 feet of the East 727.00 feet, as measured along the East and North lines respectively, thereof, of Section 20, Township 32, Range 25, Anoka County, Minnesota.

SURVEY DATA
 SURVEY INFORMATION PROVIDED BY:
 NORTHWESTERN SURVEYING & ENGINEERING, INC.
 P.O. BOX 3067
 BEMIDJI, MN 56601
 DATED: OCT. 02, 2023
 SITE BENCHMARK:
 NE COR. SEC. 20
 ELEV.=898.83

- DEMOLITION NOTES**
1. Install perimeter sediment controls as soon as possible during clear and grub operations. See Erosion Control Plan.
 2. Provide air quality control measures at the request of the Engineer or City Representatives. Take necessary measures to keep dust levels to a minimum. Provide sweeping of adjacent paving as needed, or as required by the City Engineer.
 3. Locate and protect all utility lines prior to and during demolition. Utility locations shown are based on best available information and are not guaranteed. Contact private utility service for disconnection and removal.
 4. Remove or relocate all existing site features that interfere with the proposed construction.
 5. Protect existing site features that are to remain during construction. Replace anything damaged with new construction.
 6. Pavement shall be saw cut at limits of removal unless noted otherwise. Do not impede existing traffic circulation to adjacent businesses or streets.
 7. Sufficient topsoil shall be stockpiled to allow for the replacement of 6" (4" minimum) of topsoil in disturbed areas to be re-vegetated.
 8. All construction and post-construction parking shall be on-site. At no time shall parking, loading, or unloading be allowed on public streets.
 9. Storage of materials or equipment shall not be allowed within public Right-of-Way and shall be maintained on site within project boundaries.

INDEX OF CIVIL SITE DRAWINGS:

C0	PROJECT LOCATION PLAN
C1.1-C1.2	PRELIMINARY PLAT & SITE DESIGN
C2	GRADING & DRAINAGE PLAN
C3	SANITARY & WATER UTILITY PLAN
C4	STORM SEWER UTILITY PLAN
C5	SWPPP
C6	EXISTING CONDITIONS & REMOVAL PLAN
C7.1-C7.3	DETAILS

CLIENT:
VOICE OF HOPE CHURCH
 13850 Lincoln St NE
 Ham Lake, MN 55304
 Roman Andriychuk
 763-516-4206
 roman.atozcontract@gmail.com

SITE DEVELOPMENT PROJECT
 15620 Armstrong Blvd NW
 Ramsey, MN 55303
EXISTING CONDITION & REMOVAL PLAN

I hereby certify that this plan, specification, or report was prepared by me or under my direct supervision and that I am a duly Licensed Professional Engineer under the laws of the State of Minnesota.
 Date: 7/11/24 Reg. No. 24348
 PREPARED BY: **CIVIL ENGINEERING SITE DESIGN**
 118 East Broadway St.
 PO Box 566 56362
 Mpls. 763-374-0929
 www.civilesd.com

REVISIONS	DATE	DESCRIPTION	SCALE
06/18/24 GRADING MODIFICATIONS			VERTICAL SCALE 1 inch = 10 feet
07/11/24 CITY COMMENTS			HORIZONTAL SCALE 1 inch = 22 x 90 feet (FULL SIZE SHEET 22 X 90)

DATE	06/14/24
DRAWN BY	SD
DESIGNED BY	SD
CHECKED BY	SD

FILE NO. 00948

C6
 Existing Conditions & Removal Plan

NOTE: SURMOUNTABLE CURB & GUTTER

- CATCH BASIN CASTING SHALL BE NEEHAH R-3501TB (BICYCLE SAFE) OR APPROVED EQUAL.
- FOR CATCH BASINS ADJACENT TO RADIUS, USE NEEHAH R-3246R OR APPROVED EQUAL.

NOTE: B 618 CURB & GUTTER

- CATCH BASIN CASTING SHALL BE NEEHAH R-3246 (BICYCLE SAFE) OR APPROVED EQUAL.

STANDARD CATCHBASIN CASTING

APPROVED: 1 - 2024

City of RAMSEY CITY PLATE No. **STO-4**

STANDARD DETAILS: STORMWATER CASTING

R-2560 Series or Approved Equal, Beehive Grates with Frames

SUITABLE FOR DRAINAGE ON CIRCUMSTANCES WHERE CLOGGING OF A FLAT GRATING IS A PROBLEM. EXCELLENT FOR ROADSIDE OR EARTH DITCH CATCH BASINS.

Furnished standard with ground bearing surfaces.

Grating No.	A	B	C	D	E	F	G	H	Wt. LBS.
R-2560-1	12	12	12	12	12	12	12	12	120
R-2560-2	15	15	15	15	15	15	15	15	150
R-2560-3	18	18	18	18	18	18	18	18	180
R-2560-4	21	21	21	21	21	21	21	21	210
R-2560-5	24	24	24	24	24	24	24	24	240
R-2560-6	27	27	27	27	27	27	27	27	270
R-2560-7	30	30	30	30	30	30	30	30	300
R-2560-8	33	33	33	33	33	33	33	33	330
R-2560-9	36	36	36	36	36	36	36	36	360
R-2560-10	39	39	39	39	39	39	39	39	390
R-2560-11	42	42	42	42	42	42	42	42	420
R-2560-12	45	45	45	45	45	45	45	45	450
R-2560-13	48	48	48	48	48	48	48	48	480
R-2560-14	51	51	51	51	51	51	51	51	510
R-2560-15	54	54	54	54	54	54	54	54	540
R-2560-16	57	57	57	57	57	57	57	57	570
R-2560-17	60	60	60	60	60	60	60	60	600
R-2560-18	63	63	63	63	63	63	63	63	630
R-2560-19	66	66	66	66	66	66	66	66	660
R-2560-20	69	69	69	69	69	69	69	69	690
R-2560-21	72	72	72	72	72	72	72	72	720
R-2560-22	75	75	75	75	75	75	75	75	750
R-2560-23	78	78	78	78	78	78	78	78	780
R-2560-24	81	81	81	81	81	81	81	81	810
R-2560-25	84	84	84	84	84	84	84	84	840
R-2560-26	87	87	87	87	87	87	87	87	870
R-2560-27	90	90	90	90	90	90	90	90	900
R-2560-28	93	93	93	93	93	93	93	93	930
R-2560-29	96	96	96	96	96	96	96	96	960
R-2560-30	99	99	99	99	99	99	99	99	990
R-2560-31	102	102	102	102	102	102	102	102	1020
R-2560-32	105	105	105	105	105	105	105	105	1050
R-2560-33	108	108	108	108	108	108	108	108	1080
R-2560-34	111	111	111	111	111	111	111	111	1110
R-2560-35	114	114	114	114	114	114	114	114	1140
R-2560-36	117	117	117	117	117	117	117	117	1170
R-2560-37	120	120	120	120	120	120	120	120	1200
R-2560-38	123	123	123	123	123	123	123	123	1230
R-2560-39	126	126	126	126	126	126	126	126	1260
R-2560-40	129	129	129	129	129	129	129	129	1290
R-2560-41	132	132	132	132	132	132	132	132	1320
R-2560-42	135	135	135	135	135	135	135	135	1350
R-2560-43	138	138	138	138	138	138	138	138	1380
R-2560-44	141	141	141	141	141	141	141	141	1410
R-2560-45	144	144	144	144	144	144	144	144	1440
R-2560-46	147	147	147	147	147	147	147	147	1470
R-2560-47	150	150	150	150	150	150	150	150	1500
R-2560-48	153	153	153	153	153	153	153	153	1530
R-2560-49	156	156	156	156	156	156	156	156	1560
R-2560-50	159	159	159	159	159	159	159	159	1590
R-2560-51	162	162	162	162	162	162	162	162	1620
R-2560-52	165	165	165	165	165	165	165	165	1650
R-2560-53	168	168	168	168	168	168	168	168	1680
R-2560-54	171	171	171	171	171	171	171	171	1710
R-2560-55	174	174	174	174	174	174	174	174	1740
R-2560-56	177	177	177	177	177	177	177	177	1770
R-2560-57	180	180	180	180	180	180	180	180	1800
R-2560-58	183	183	183	183	183	183	183	183	1830
R-2560-59	186	186	186	186	186	186	186	186	1860
R-2560-60	189	189	189	189	189	189	189	189	1890
R-2560-61	192	192	192	192	192	192	192	192	1920
R-2560-62	195	195	195	195	195	195	195	195	1950
R-2560-63	198	198	198	198	198	198	198	198	1980
R-2560-64	201	201	201	201	201	201	201	201	2010
R-2560-65	204	204	204	204	204	204	204	204	2040
R-2560-66	207	207	207	207	207	207	207	207	2070
R-2560-67	210	210	210	210	210	210	210	210	2100
R-2560-68	213	213	213	213	213	213	213	213	2130
R-2560-69	216	216	216	216	216	216	216	216	2160
R-2560-70	219	219	219	219	219	219	219	219	2190
R-2560-71	222	222	222	222	222	222	222	222	2220
R-2560-72	225	225	225	225	225	225	225	225	2250
R-2560-73	228	228	228	228	228	228	228	228	2280
R-2560-74	231	231	231	231	231	231	231	231	2310
R-2560-75	234	234	234	234	234	234	234	234	2340
R-2560-76	237	237	237	237	237	237	237	237	2370
R-2560-77	240	240	240	240	240	240	240	240	2400
R-2560-78	243	243	243	243	243	243	243	243	2430
R-2560-79	246	246	246	246	246	246	246	246	2460
R-2560-80	249	249	249	249	249	249	249	249	2490
R-2560-81	252	252	252	252	252	252	252	252	2520
R-2560-82	255	255	255	255	255	255	255	255	2550
R-2560-83	258	258	258	258	258	258	258	258	2580
R-2560-84	261	261	261	261	261	261	261	261	2610
R-2560-85	264	264	264	264	264	264	264	264	2640
R-2560-86	267	267	267	267	267	267	267	267	2670
R-2560-87	270	270	270	270	270	270	270	270	2700
R-2560-88	273	273	273	273	273	273	273	273	2730
R-2560-89	276	276	276	276	276	276	276	276	2760
R-2560-90	279	279	279	279	279	279	279	279	2790
R-2560-91	282	282	282	282	282	282	282	282	2820
R-2560-92	285	285	285	285	285	285	285	285	2850
R-2560-93	288	288	288	288	288	288	288	288	2880
R-2560-94	291	291	291	291	291	291	291	291	2910
R-2560-95	294	294	294	294	294	294	294	294	2940
R-2560-96	297	297	297	297	297	297	297	297	2970
R-2560-97	300	300	300	300	300	300	300	300	3000
R-2560-98	303	303	303	303	303	303	303	303	3030
R-2560-99	306	306	306	306	306	306	306	306	3060
R-2560-100	309	309	309	309	309	309	309	309	3090

Light Duty
Total Weight 170 Pounds

Furnished standard with ground bearing surfaces.

STORM CASTINGS FOR NON-TRAFFIC AREAS

APPROVED: 9 - 2011

City of RAMSEY CITY PLATE No. **STO-6**

STANDARD DETAILS: STORM CASTING - NON TRAFFIC AREAS

SECTION A-A

GROUT BOTTOM TO SLOPE TOWARD PIPE AS SHOWN BY ARROWS

FORM 1/2 PIPE SECTION OF LARGEST DIAMETER PIPE

ALL INTERIOR JOINTS SHALL BE GROUTED TO A SMOOTH FINISH

CASTING PER PLAN

WRAP OUTSIDE OF RINGS WITH WATER TIGHT PRODUCT

WALLS TO BE CONSTRUCTED OF PRECAST SECTIONS. JOINTS SHALL BE CONSTRUCTED WITH CONFIRMED O-RING GASKETS

CONCRETE SLAB

GROUT FLOW LINE AS SHOWN ABOVE

STANDARD DETAIL

NOTES:

- MANHOLE INVERT SHALL SLOPE TO PROVIDE A SMOOTH FLOW FROM INLET TO OUTLET
- INSPECTION OF MANHOLE REQUIRED BEFORE BACKFILLING
- ALL INLET INVERTS TO BE 0.10 ABOVE OUTLET INVERTS UNLESS OTHERWISE NOTED
- CONCRETE ADJUSTING RINGS TO BE INSTALLED MAX 7-2" RINGS, MIN 2-2" RINGS
- GROUT BETWEEN RINGS, SHIMS SHALL BE METAL, CONCRETE OR PLASTIC
- A 12 GAUGE COPPER CLAD STEEL TRACER WIRE IS REQUIRED WITH ALL STORM LINES
- CONDUCTIVITY IS REQUIRED ON ALL TRACER WIRE
- STEPS ARE REQUIRED IF STRUCTURE FROM THE CASTING TO THE INVERT IS GREATER THAN 4 FEET
- TRACER WIRES ARE TO END IN STRUCTURES, AT FINISHED GRADE ON ALL SERVICES AND STUBS

APPROVED: 1 - 2024

City of RAMSEY CITY PLATE No. **STO-3**

STANDARD DETAILS: STORM MANHOLE

5' FIBERGLASS RED/WHITE HYDRANT MARKER WITH SPRING 5" OR AS SHOWN ON PLANS

VALVE BOX

TRACER WIRE BOX

UNDISTURBED SOIL

MIN 7'-6"

2'-6"

6" VALVE

18" MINIMUM SEPARATION FROM SANITARY SEWER TO WATERMAIN, INSULATE IF LESS THAN 24"

CONCRETE BLOCKING

1 C.Y. OF COURSE GRAVEL

CONC. BLOCK BASE

6" D.I.P.

18" MINIMUM SEPARATION FROM SANITARY SEWER TO WATERMAIN, INSULATE IF LESS THAN 24"

TOP VIEW-TEE

TOP VIEW-BEND

TOP VIEW-PLUG

NOTES:

- HYDRANT SHALL BE 5-1/4" WB67 WATEROUS PACER OR APPROVED EQUAL.
- HYDRANTS TO BE ORDERED FOR 8'-0" BURY. IN AREAS OF EXTRA DEPTH ON THE WATERMAIN, HYDRANTS EXTENSIONS MAY BE REQUIRED.
- HYDRANTS SHALL BE BLOCKED OR TIED TO THE TEE AT MAIN WITH 2-3/4" DIAMETER TIE RODS. ALL THE RODS TO BE COAL TAR COATED AFTER INSTALLATION. RESTRAINED JOINT PIPE AND RETAINING GLANDS MAY BE USED.
- TOP NUT OF HYDRANT 2.5' ABOVE TOP BACK OF CURB OR BITUMINOUS SURFACE.
- HYDRANTS BURIED BELOW WATER TABLE, DRAIN HOLES NEED TO BE PLUGGED AND HYDRANT MARKED BY PAINTING 5" CAP YELLOW.
- BRUSH PAINT ALL HYDRANTS AFTER INSTALLATION IS COMPLETE.
- PUMPER NOZZLE 5.75" O.D. X 4" T.P.I., HOSE NOZZLE 3.06" O.D. X 7" T.P.I.
- 12 GAUGE COPPER CLAD STEEL TRACER WIRE IS REQUIRED WITH ALL WATER LINES [FOR DETAILED INFO. REFER TO MINNESOTA RURAL WATER ASSOCIATION TRACER WIRE SPECIFICATION AT WWW.MRWVA.COM]

APPROVED: 1 - 2024

City of RAMSEY CITY PLATE No. **WAT-1**

STANDARD DETAILS: HYDRANT

TOP VIEW-TEE

TOP VIEW-BEND

TOP VIEW-PLUG

PIPE SIZE	22 1/2% BEND			45% BEND			90% BEND			
	A	B	C	A	B	C	A	B	C	
12"	1-10"	1-10"	2-0"	3-4"	2-0"	2-0"	6-9"	2-6"	2-0"	
16"	3-5"	2-5"	2-5"	3-10"	3-5"	2-5"	6-9"	3-6"	2-6"	
20"	3-6"	2-8"	3-0"	3-6"	3-0"	3-0"	6-9"	4-0"	2-6"	
24"	4-4"	3-5"	3-5"	3-10"	3-10"	3-5"	6-9"	3-5"	3-5"	
30"	-	-	-	3-6"	6-3"	6-0"	1-5"	12-0"	6-0"	3-6"

NOTES:

- BLOCKING TO BE POURED CONCRETE, MNDOT MIX DESIGN 3A32.
- FITTINGS MUST BE COVERED W/POLY (8 MIL) PRIOR TO POURING CONCRETE
- KEEP CONCRETE CLEAR OF BOLTS, JOINT AND ACCESSORIES.

APPROVED: 1 - 2024

City of RAMSEY CITY PLATE No. **WAT-8**

STANDARD DETAILS: THRUST BLOCKS

Ø MH	"
48"	0.73
54"	0.98
60"	1.23
66"	1.48
72"	1.73
78"	1.98
84"	2.23
90"	2.48
96"	2.73
102"	2.98
108"	3.23
120"	3.73
132"	4.23
144"	4.73
168"	5.73

APPROVED: 4 - 2005

City of RAMSEY CITY PLATE No. **STO-5**

STANDARD DETAILS: SLAB TOP MANHOLE COVER

RECTANGULAR

CIRCULAR

NOTES:

- MANHOLE INVERT SHALL SLOPE TO PROVIDE A SMOOTH FLOW FROM INLET TO OUTLET
- CONCRETE BASE SHALL BE 6" POURED IN PLACE OR 5" PRECAST SLAB
- CONCRETE ADJUSTING RINGS TO BE INSTALLED MAX 7-2" RINGS, MIN 2-2" RINGS
- GROUT BETWEEN RINGS, SHIMS SHALL BE METAL, CONCRETE OR PLASTIC
- INSPECTION OF MANHOLE REQUIRED BEFORE BACKFILLING
- A 12 GAUGE COPPER CLAD STEEL TRACER WIRE IS REQUIRED WITH ALL

Notes:
 1. INSTALLATION OF 4" OF TOPSOIL REQUIRED ACROSS ALL DISTURBED AREAS.
 2. TOPSOIL IS DEFINED AS BLACK DIRT COMPOSED OF UNCONSOLIDATED MATERIAL, LARGELY UNDECOMPOSED ORGANIC MATTER WHICH IS SUITABLE FOUNDATION FOR VEGETATIVE GROWTH.
 3. THE COMPOSITION OF TOPSOIL SHOULD CONTAIN NO MORE THAN THIRTY-FIVE PERCENT (35%) SAND CONTENT.

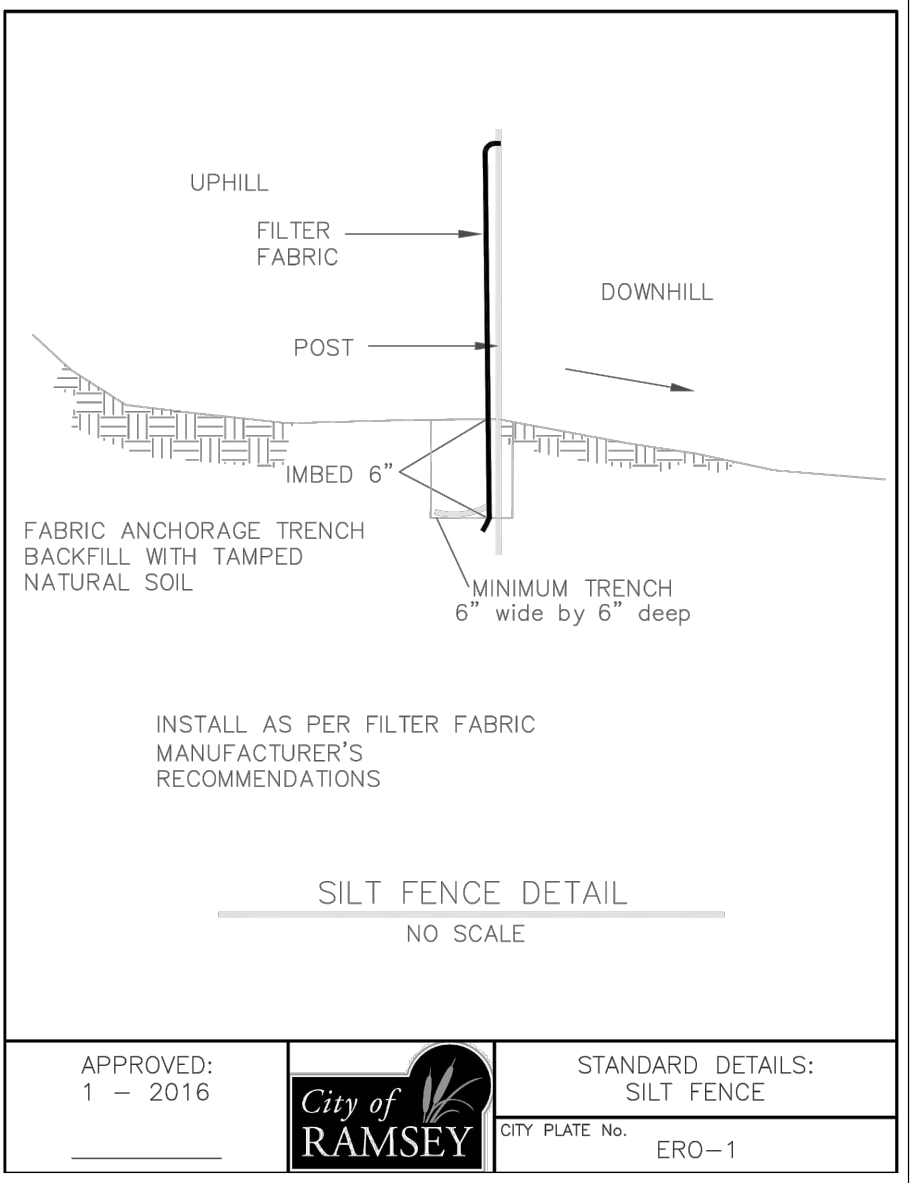
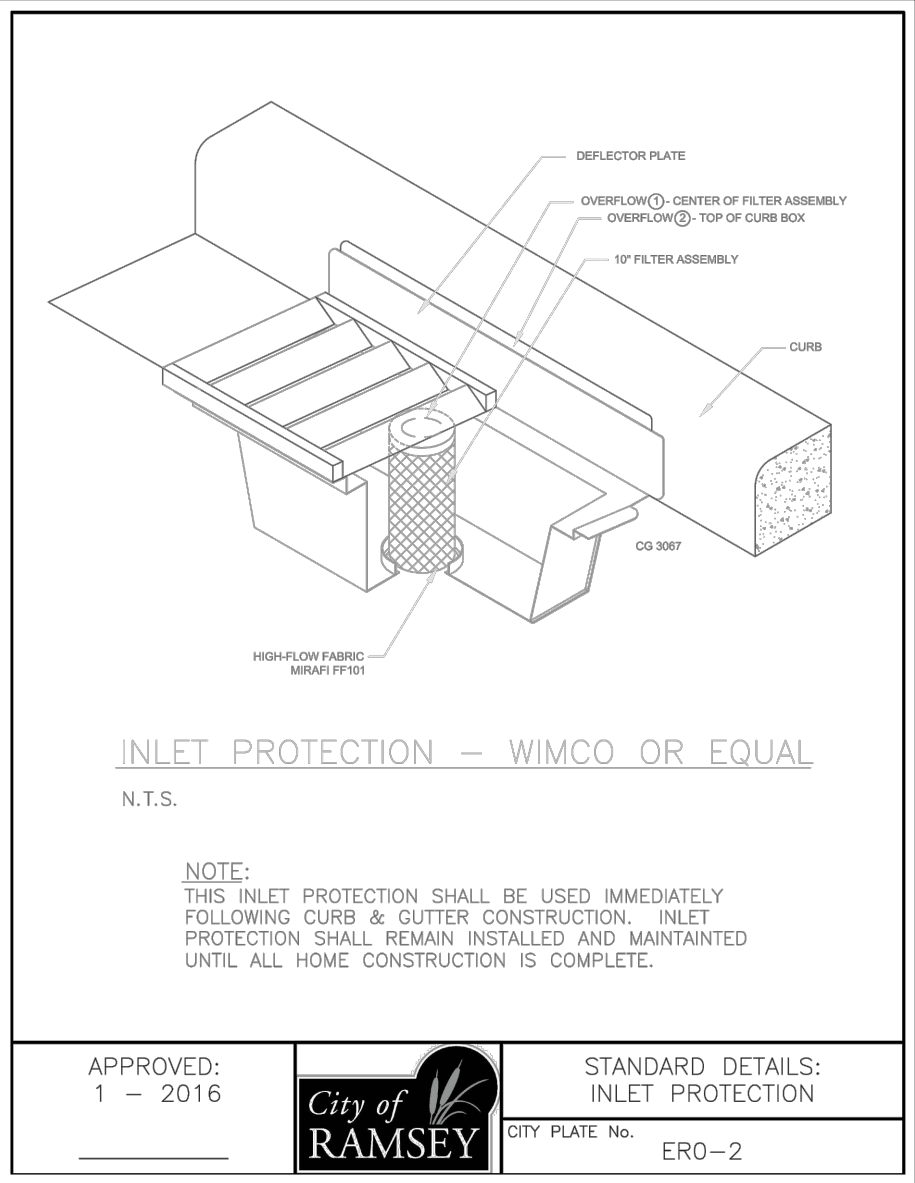
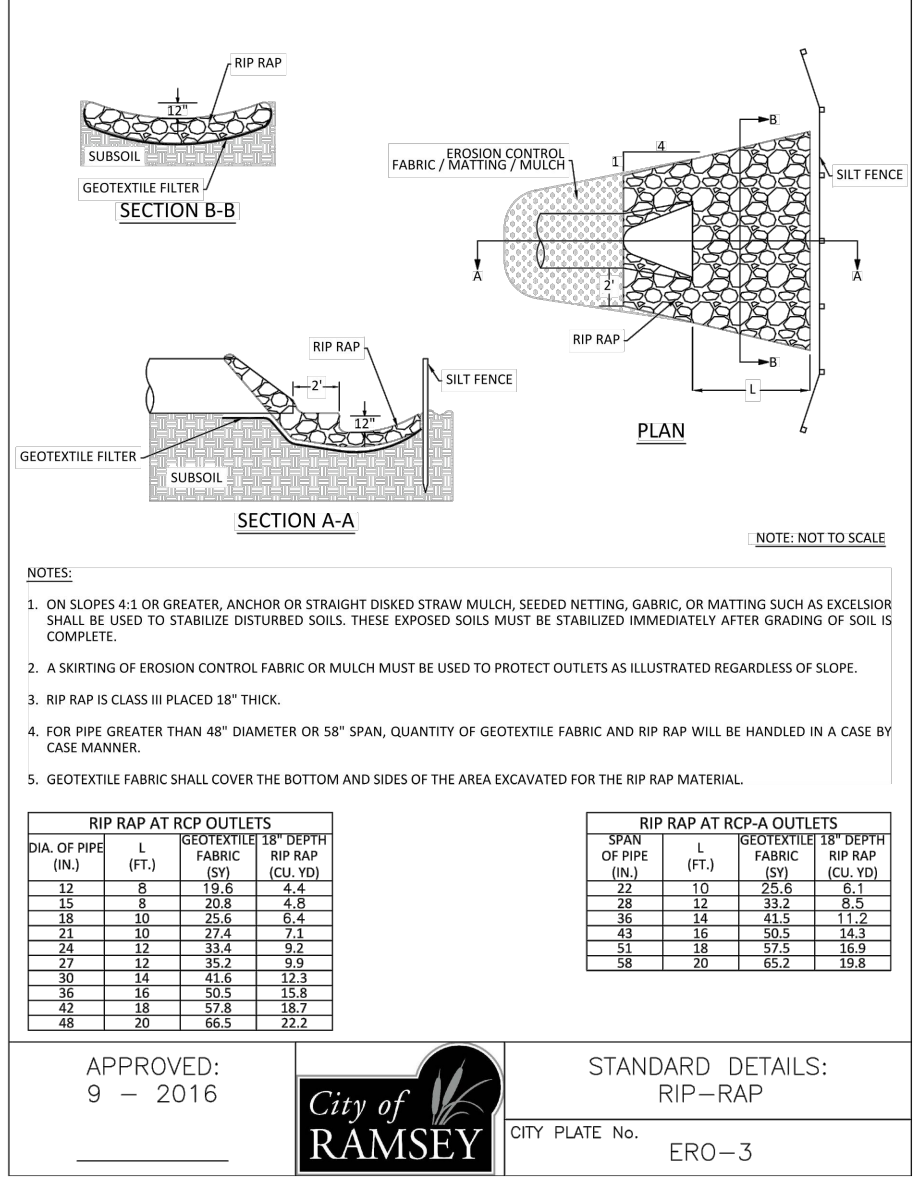
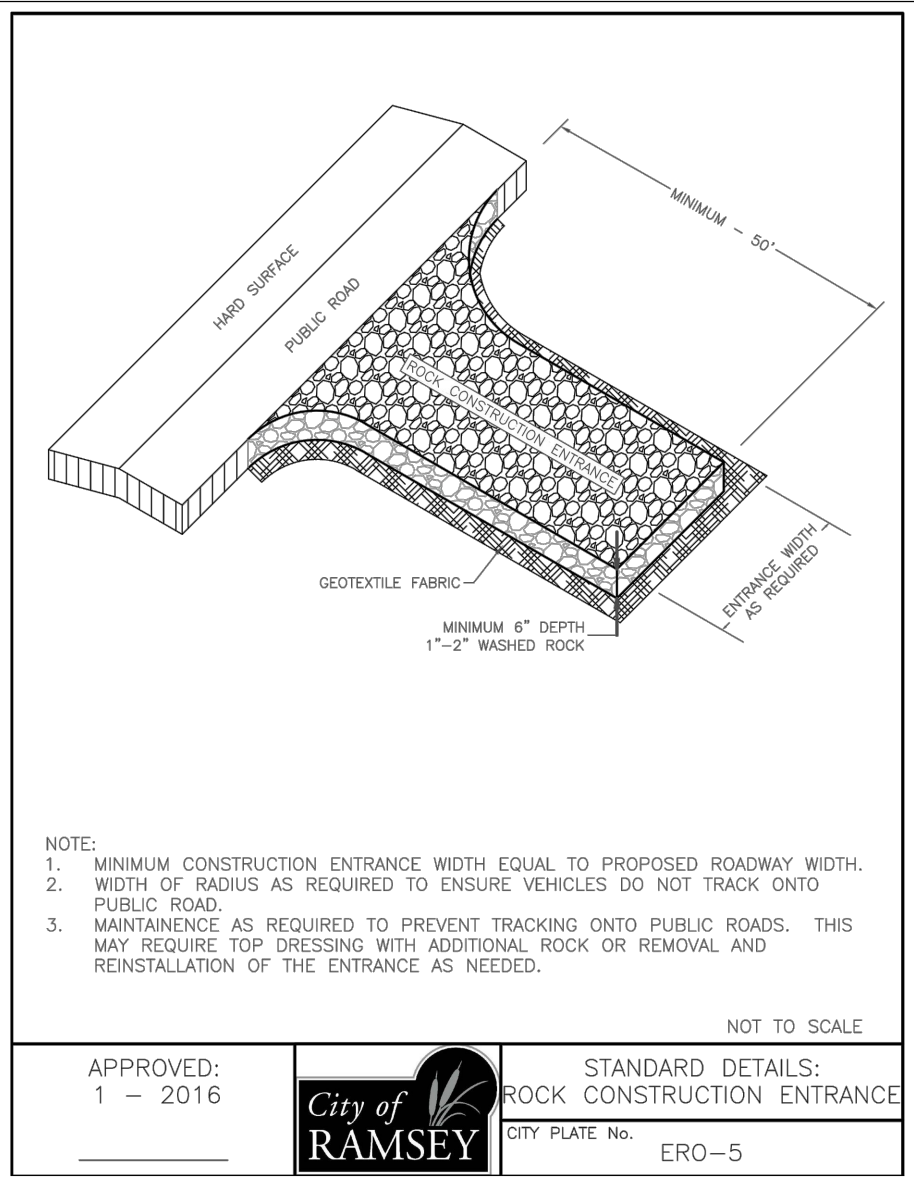
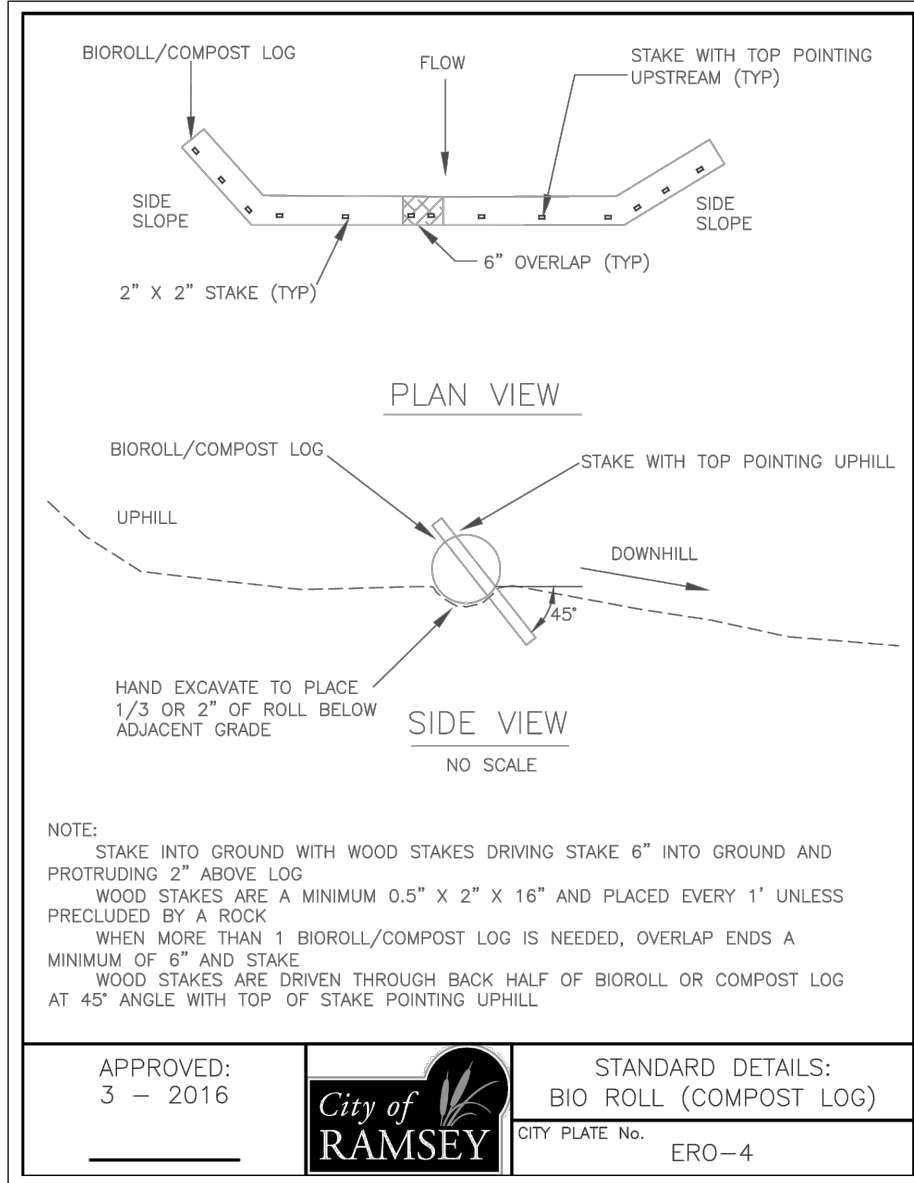

CLIENT:
VOICE OF HOPE CHURCH
 13850 Lincoln St NE
 Ham Lake, MN 55304
 Roman Andriychuk
 763-516-4206
 roman.atozcontract@gmail.com

SITE DEVELOPMENT PROJECT
 15620 Armstrong Blvd NW
 Ramsey, MN 55303
DETAILS

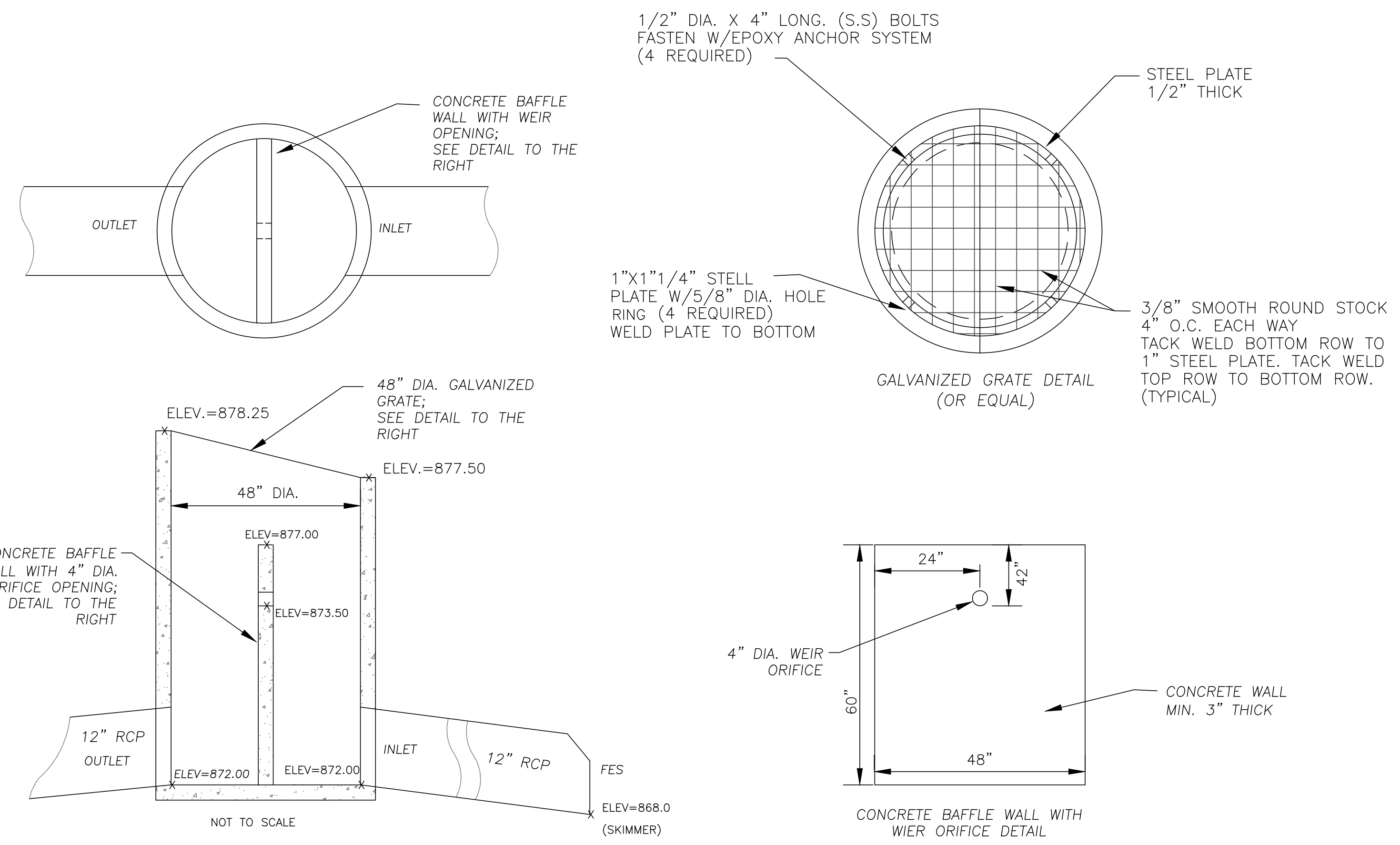

BASIN OUTLET CONTROL STRUCTURE (OCS-1)
 NOT TO SCALE

INDEX OF CIVIL SITE DRAWINGS:

C0	PROJECT LOCATION PLAN
C1.1-C1.2	PRELIMINARY PLAT & SITE DESIGN
C2	GRADING & DRAINAGE PLAN
C3	SANITARY & WATER UTILITY PLAN
C4	STORM SEWER UTILITY PLAN
C5	SWPPP
C6	EXISTING CONDITIONS & REMOVAL PLAN
C7.1-C7.3	DETAILS

I hereby certify that this plan, specification, or report was prepared by me or under my direct supervision and that I am a duly Licensed Professional Engineer under the laws of the State of Minnesota.
 Date: 7/11/24 Reg. No. 24348
 PREPARED BY: CIVIL ENGINEERING SITE DESIGN
 116 East Broadway St.
 PO Box 566
 Monticello, Mn 55362
 Phone: 763-314-0929
 www.civilss.com

REVISIONS

06/18/24	GRADING MODIFICATIONS
07/11/24	CITY COMMENTS

DATE: 06/14/24
 DRAWN BY: SD
 DESIGNED BY: SD
 CHECKED BY: SD

VERTICAL SCALE: 1 inch = feet
 HORIZONTAL SCALE: 1 inch = feet (FULL SIZE SHEET 22 X 30)

FILE NO. 00948

C7.3
 Details