

EXISTING TOPOGRAPHIC SYMBOLS

	ACCESS GRATE		REGULATION STATION GAS
	AIR CONDITION UNIT		SATELLITE DISH
	ANTENNA		SIGN TRAFFIC
	AUTO SPRINKLER CONNECTION		SIGNAL CONTROL CABINET
	BARRICADE PERMANENT		SOIL BORING
	BASKETBALL POST		SIREN
	BENCH		TELEPHONE BOOTH
	BIRD FEEDER		TILE INLET
	BOLLARD		TILE OUTLET
	BUSH		TILE RISER
	CATCH BASIN RECTANGULAR CASTING		TRANSFORMER-ELECTRIC
	CATCH BASIN CIRCULAR CASTING		TREE-CONIFEROUS
	CURB STOP		TREE-DEAD
	CLEAN OUT		TREE-DECIDUOUS
	CULVERT END		TREE STUMP
	DRINKING FOUNTAIN		TRAFFIC ARM BARRIER
	DOWN SPOUT		TRAFFIC SIGNAL
	ELECTRIC CAR CHARGE STATION		TRASH CAN
	FILL PIPE		UTILITY MARKER
	FIRE HYDRANT		VALVE
	FLAG POLE		VALVE POST INDICATOR
	FLARED END / APRON		VALVE VAULT
	FUEL PUMP		VAULT
	GRILL		VENT PIPE
	GUY WIRE ANCHOR		WATER SPIGOT
	HANDHOLE		WELL
	HANDICAP SPACE		WETLAND DELINEATED MARKER
	IRRIGATION SPRINKLER HEAD		WETLAND
	IRRIGATION VALVE BOX		WET WELL
	LIFT STATION CONTROL PANEL		YARD HYDRANT
	LIFT STATION		
	LIGHT POLE		
	MAILBOX		
	MANHOLE-COMMUNICATION		
	MANHOLE-ELECTRIC		
	MANHOLE-GAS		
	MANHOLE-HEAT		
	MANHOLE-RECLAIMED WATER		
	MANHOLE-SANITARY SEWER		
	MANHOLE-STORM SEWER		
	MANHOLE-UTILITY		
	MANHOLE-WATER		
	METER		
	DRIVE-THRU MICROPHONE		
	PARKING METER		
	PAVEMENT MARKING		
	PEDESTAL-COMMUNICATION		
	PEDESTAL-ELECTRIC		
	PEDESTRIAN PUSH BUTTON		
	PICNIC TABLE		
	POLE-UTILITY		
	POST		
	RAILROAD SIGNAL POLE		

PROPOSED TOPOGRAPHIC SYMBOLS

	CLEANOUT
	MANHOLE
	LIFT STATION
	STORM SEWER CIRCULAR CASTING
	STORM SEWER RECTANGULAR CASTING
	STORM SEWER FLARED END / APRON
	STORM SEWER OUTLET STRUCTURE
	STORM SEWER OVERFLOW STRUCTURE
	CURB BOX
	FIRE HYDRANT
	WATER VALVE
	WATER REDUCER
	WATER BEND
	WATER TEE
	WATER CROSS
	WATER SLEEVE
	WATER CAP / PLUG
	RIP RAP
	DRAINAGE FLOW
	TRAFFIC SIGNS

SURVEY SYMBOLS

	BENCHMARK LOCATION		CAST IRON MONUMENT
	CONTROL POINT		STONE MONUMENT
	MONUMENT FOUND		

EXISTING TOPOGRAPHIC LINES

	RETAINING WALL
	FENCE
	FENCE-DECORATIVE
	GUARD RAIL
	TREE LINE
	BUSH LINE

SURVEY LINES

	CONTROLLED ACCESS BOUNDARY
	CENTERLINE
	EXISTING EASEMENT LINE
	PROPOSED EASEMENT LINE
	EXISTING LOT LINE
	PROPOSED LOT LINE
	EXISTING RIGHT-OF-WAY
	PROPOSED RIGHT-OF-WAY
	SETBACK LINE
	SECTION LINE
	QUARTER LINE
	SIXTEENTH LINE
	TEMPORARY EASEMENT

EXISTING UTILITY LINES

	FORCEMAIN
	SANITARY SEWER
	SANITARY SERVICE
	STORM SEWER
	STORM SEWER DRAIN TILE
	WATERMAIN
	WATER SERVICE
	RECLAIMED WATER

PROPOSED UTILITY LINES

	FORCEMAIN
	SANITARY SEWER
	SANITARY SERVICE
	STORM SEWER
	STORM SEWER DRAIN TILE
	WATERMAIN
	WATER SERVICE
	PIPE CASING
	TRENCHLESS PIPE (PLAN VIEW)
	TRENCHLESS PIPE (PROFILE VIEW)

GRADING INFORMATION

	EXISTING CONTOUR MINOR
	EXISTING CONTOUR MAJOR
	PROPOSED CONTOUR MINOR
	PROPOSED CONTOUR MAJOR
	PROPOSED GRADING LIMITS / SLOPE LIMITS
	PROJECT LIMITS
	PROPOSED SPOT ELEVATION
	RISE:RUN (SLOPE)

HATCH PATTERNS

	BITUMINOUS		GRAVEL
	CONCRETE		

EXISTING PRIVATE UTILITY LINES

NOTE: EXISTING UTILITY INFORMATION SHOWN ON THIS PLAN HAS BEEN PROVIDED BY THE UTILITY OWNER. THE CONTRACTOR SHALL FIELD VERIFY EXACT LOCATIONS PRIOR TO COMMENCING CONSTRUCTION AS REQUIRED BY STATE LAW. NOTIFY GOPHER STATE ONE CALL, 1-800-252-1166 OR 651-454-0002.

THE SUBSURFACE UTILITY INFORMATION IN THIS PLAN IS UTILITY QUALITY LEVEL D UNLESS OTHERWISE NOTED. THIS UTILITY LEVEL WAS DETERMINED ACCORDING TO THE GUIDELINES OF CI/ASCE 38-22, ENTITLED "STANDARD GUIDELINE FOR INVESTIGATING AND DOCUMENTING EXISTING UTILITIES".

	UNDERGROUND FIBER OPTIC
	UNDERGROUND ELECTRIC
	UNDERGROUND GAS
	UNDERGROUND COMMUNICATION
	OVERHEAD ELECTRIC
	OVERHEAD COMMUNICATION
	OVERHEAD UTILITY

UTILITIES IDENTIFIED WITH A QUALITY LEVEL :

LINE TYPES FOLLOW THE FORMAT: UTILITY TYPE - QUALITY LEVEL
 EXAMPLE: G-A UNDERGROUND GAS, QUALITY LEVEL A
 UTILITY QUALITY LEVEL (A,B,C,D) DEFINITIONS CAN BE FOUND IN CI/ASCE 38-22.

UTILITY QUALITY LEVELS:

QUALITY LEVEL D: PROVIDES THE MOST BASIC LEVEL OF INFORMATION. IT INVOLVES COLLECTING DATA FROM EXISTING UTILITY RECORDS. RECORDS MAY INCLUDE AS-BUILT DRAWINGS, DISTRIBUTION AND SERVICES MAPS, EXISTING GEOGRAPHIC INFORMATION SYSTEM DATABASES, CONSTRUCTION PLANS, ETC.

QUALITY LEVEL C: INVOLVES SURVEYING VISIBLE SUBSURFACE UTILITY STRUCTURES SUCH AS MANHOLES, HAND-HOLES, UTILITY VALVES AND METERS, FIRE HYDRANTS, PEDESTALS AND UTILITY MARKERS, AND THEN CORRELATING THE INFORMATION WITH EXISTING UTILITY RECORDS TO CREATE COMPOSITE DRAWINGS. INCLUDES QUALITY LEVEL D ACTIVITIES.

QUALITY LEVEL B: INVOLVES DESIGNATING THE HORIZONTAL POSITION OF SUBSURFACE UTILITIES THROUGH SURFACE DETECTION METHODS AND COLLECTING THE INFORMATION THROUGH A SURVEY METHOD. INCLUDES QUALITY LEVEL C AND D TASKS.

QUALITY LEVEL A: PROVIDES THE HIGHEST LEVEL OF ACCURACY. IT INVOLVES LOCATING OR POTHOLING UTILITIES AS WELL AS ACTIVITIES IN QUALITY LEVELS B, C, AND D. THE LOCATED FACILITY INFORMATION IS SURVEYED AND MAPPED AND THE DATA PROVIDES PRECISE PLAN AND PROFILE INFORMATION.

ABBREVIATIONS

A	ALGEBRAIC DIFFERENCE	GRAV	GRAVEL	RSC	RIGID STEEL CONDUIT
ADJ	ADJUST	GU	GUTTER	RT	RIGHT
ALT	ALTERNATE	GV	GATE VALVE	SAN	SANITARY SEWER
B-B	BACK TO BACK	HDPE	HIGH DENSITY POLYETHYLENE	SCH	SCHEDULE
BIT	BITUMINOUS	HH	HANDHOLE	SERV	SERVICE
BLDG	BUILDING	HP	HIGH POINT	SHLD	SHOULDER
BMP	BEST MANAGEMENT PRACTICE	HWL	HIGH WATER LEVEL	STA	STATION
BR	BEGIN RADIUS	HYD	HYDRANT	STD	STANDARD
BV	BUTTERFLY VALVE	I	INVERT	STM	STORM SEWER
CB	CATCH BASIN	K	CURVE COEFFICIENT	TC	TOP OF CURB
C&G	CURB AND GUTTER	L	LENGTH	TE	TEMPORARY EASEMENT
CIP	CAST IRON PIPE	LO	LOWEST OPENING	TEMP	TEMPORARY
CIPP	CURED-IN-PLACE PIPE	LP	LOW POINT	TNH	TOP NUT HYDRANT
CL	CENTER LINE	LT	LEFT	TP	TOP OF PIPE
CL	CLASS	MAX	MAXIMUM	TYP	TYPICAL
CLVT	CULVERT	MH	MANHOLE	VCP	VITRIFIED CLAY PIPE
CMP	CORRUGATED METAL PIPE	MIN	MINIMUM	VERT	VERTICAL
C.O.	CHANGE ORDER	MR	MID RADIUS	VPC	VERTICAL POINT OF CURVE
COMM	COMMUNICATION	NIC	NOT IN CONTRACT	VPI	VERTICAL POINT OF INTERSECTION
CON	CONCRETE	NMC	NON-METALLIC CONDUIT	VPT	VERTICAL POINT OF TANGENT
CSP	CORRUGATED STEEL PIPE	NTS	NOT TO SCALE	WM	WATERMAIN
DIA	DIAMETER	NWL	NORMAL WATER LEVEL		
DIP	DUCTILE IRON PIPE	OHW	ORDINARY HIGH WATER LEVEL		
DWY	DRIVEWAY	PC	POINT OF CURVE	AC	ACRES
E	EXTERNAL CURVE DISTANCE	PCC	POINT OF COMPOUND CURVE	CF	CUBIC FEET
ELEC	ELECTRIC	PE	PERMANENT EASEMENT	CV	COMPACTED VOLUME
ELEV	ELEVATION	PED	PEDESTRIAN, PEDESTAL	CY	CUBIC YARD
EOF	EMERGENCY OVERFLOW	PERF	PERFORATED PIPE	EA	EACH
ER	END RADIUS	PERM	PERMANENT	EV	EXCAVATED VOLUME
ESMT	EASEMENT	PI	POINT OF INTERSECTION	LB	POUND
EX	EXISTING	PL	PROPERTY LINE	LF	LINEAR FEET
FES	FLARED END SECTION	PRC	POINT OF REVERSE CURVE	LS	LUMP SUM
F-F	FACE TO FACE	PT	POINT OF TANGENT	LV	LOOSE VOLUME
FF	FINISHED FLOOR	PVC	POLYVINYL CHLORIDE PIPE	SF	SQUARE FEET
F&I	FURNISH AND INSTALL	PVMT	PAVEMENT	SV	STOCKPILE VOLUME
FM	FORCEMAIN	R	RADIUS	SY	SQUARE YARD
FO	FIBER OPTIC	R/W	RIGHT-OF-WAY		
F.O.	FIELD ORDER	RCP	REINFORCED CONCRETE PIPE		
GRAN	GRANULAR	RET	RETAINING		

© Bolton & Menk, Inc. 2024. All Rights Reserved. P:\MINNESOTA\CAD\CAD135159602.dwg 8/20/2024 4:05:31 PM

I HEREBY CERTIFY THAT THIS PLAN, SPECIFICATION, OR REPORT WAS PREPARED BY ME OR UNDER MY DIRECT SUPERVISION AND THAT I AM A DULY LICENSED PROFESSIONAL ENGINEER UNDER THE LAWS OF THE STATE OF MINNESOTA.

 KEVIN P. KIEHL
 LIC. NO. 23211 DATE 8/20/2024



7533 SUNWOOD DR NW, SUITE 206
 RAMSEY, MN 55303
 Phone: (763) 433-2851
 Email: Ramsey@bolton-menk.com
 www.bolton-menk.com



DESIGNED	NO.	ISSUED FOR	DATE
ZFL			
TJH			
KPK			
CLIENT PROJ. NO.:	CP-25-01		

CITY OF RAMSEY, MINNESOTA		SHEET
RIVERS BEND REGIONAL STORMWATER IMPROVEMENTS		2
LEGEND		OF
		12



- NOTES:**
1. THE CONTRACTOR SHALL REMOVE ALL TREES WITHIN LIMITS SHOWN INCLUDING CHIPS, BRUSH, STUMPS, AND ROOTS. DISPOSE OF TREES AND BRUSH OFF-SITE.
 2. VERIFY CLEARING LIMITS WITH ENGINEER PRIOR TO TREE REMOVAL OPERATIONS.
 3. THE CONTRACTOR SHALL FIELD VERIFY EXACT UTILITY LOCATIONS PRIOR TO COMMENCING CONSTRUCTION AS REQUIRED BY STATE LAW. NOTIFY GOPHER STATE ONE CALL, 1-800-252-1166 OR 651-454-0002.



LEGEND					
	CLEAR & GRUB TREES		CURB & GUTTER		BOLLARD
	TREE-CONIFEROUS		EXISTING EASEMENT LINE		POST
	TREE-DECIDUOUS		EXISTING RIGHT-OF-WAY		UTILITY MARKER - GAS
	CLEANOUT		FENCE		TRANSFORMER-ELECTRIC
	STORM MANHOLE		UNDERGROUND GAS		PEDESTAL-COMMUNICATION
	SANITARY MANHOLE		UNDERGROUND COMM		PEDESTAL-ELECTRIC
	STORM CATCH BASIN		OVERHEAD UTILITY		HANDHOLE
	FLARED END SECITON VALVE		FIBER OPTIC LINE		POLE-UTILITY
			WATERMAIN		GUY WIRE ANCHOR
			SANITARY SEWER		EXISTING TRAFFIC SIGN
			STORM SEWER		FIRE HYDRANT
			RUM RIVER FLOOD PLAIN		
			DELINEATED WETLAND		

© Bolton & Menk, Inc. 2024. All Rights Reserved. P:\RAMSEY\2411315960\CAD\CSD\3D\13159603.dwg 8/20/2024 4:06:03 PM

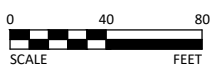

I HEREBY CERTIFY THAT THIS PLAN, SPECIFICATION, OR REPORT WAS PREPARED BY ME OR UNDER MY DIRECT SUPERVISION AND THAT I AM A DULY LICENSED PROFESSIONAL ENGINEER UNDER THE LAWS OF THE STATE OF MINNESOTA.

Kevin P. Kiehl
 KEVIN P. KIEHL
 LIC. NO. 23211 DATE 8/20/2024



7533 SUNWOOD DR NW, SUITE 206
 RAMSEY, MN 55303
 Phone: (763) 433-2851
 Email: Ramsey@bolton-menk.com
 www.bolton-menk.com



DESIGNED	NO.	ISSUED FOR	DATE
ZFL			
DRAWN	TJH		
CHECKED	KPK		
CLIENT PROJ. NO.	CP-25-01		

CITY OF RAMSEY, MINNESOTA
 RIVERS BEND REGIONAL STORMWATER IMPROVEMENTS
 EXISTING CONDITIONS & REMOVALS

SHEET 3 OF 12

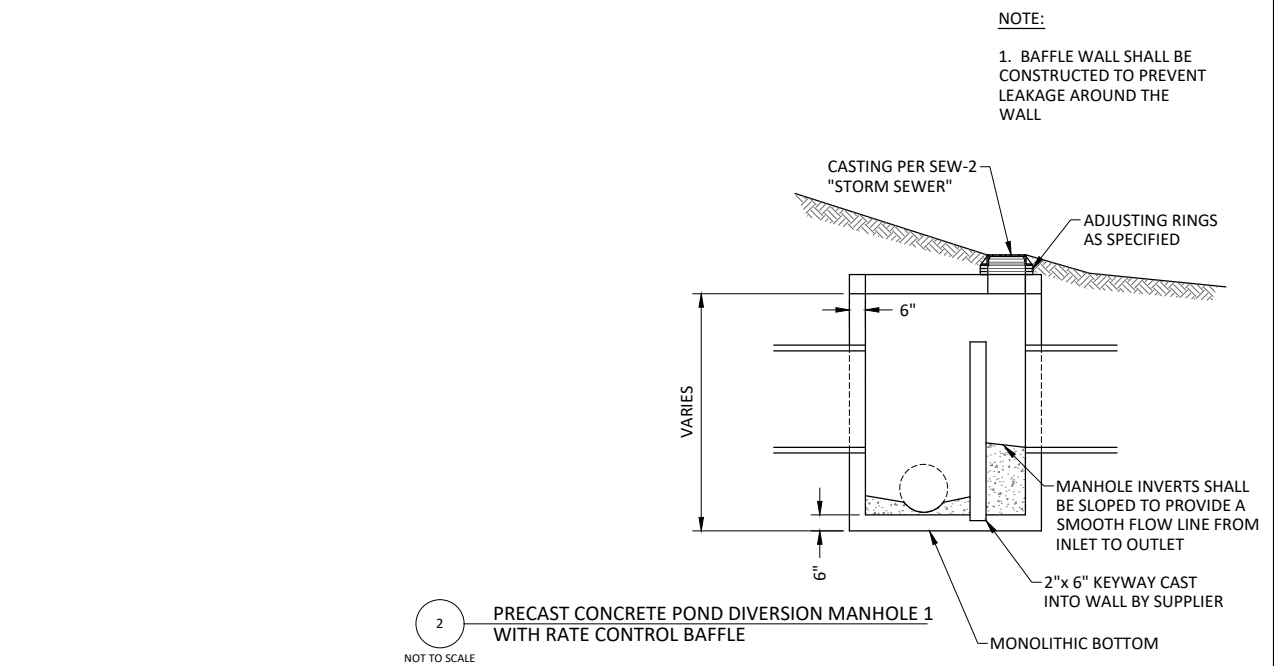
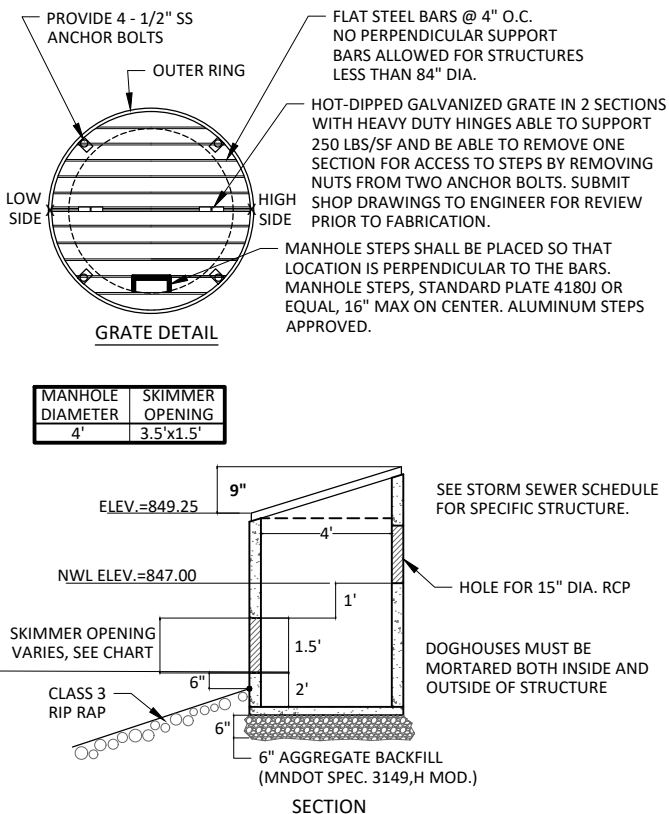
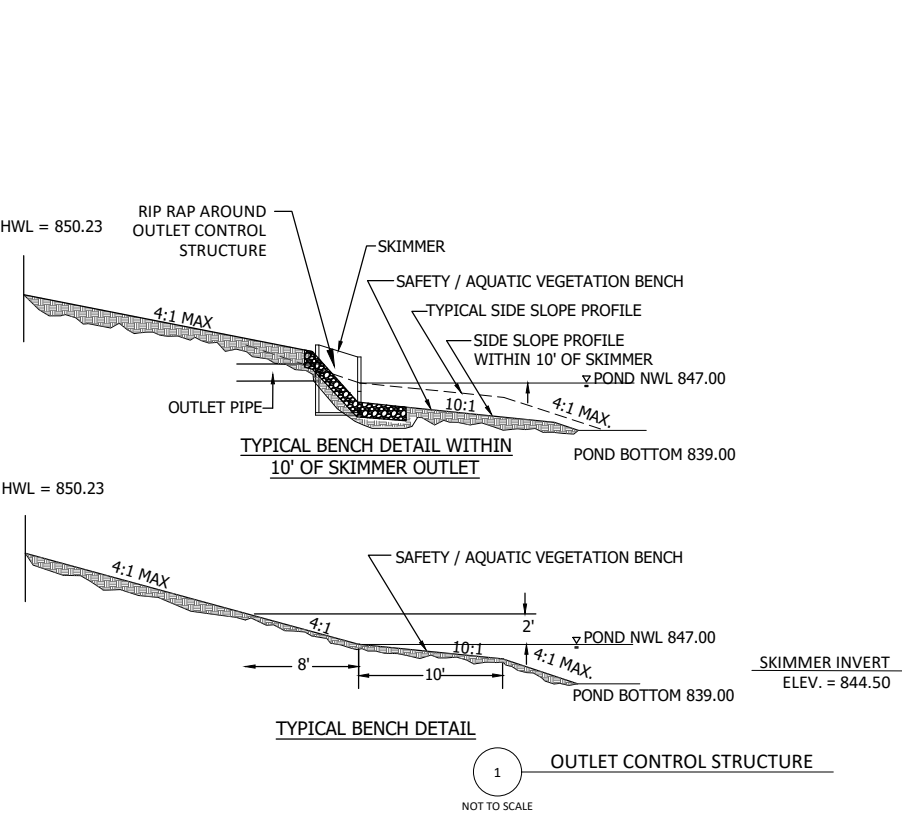
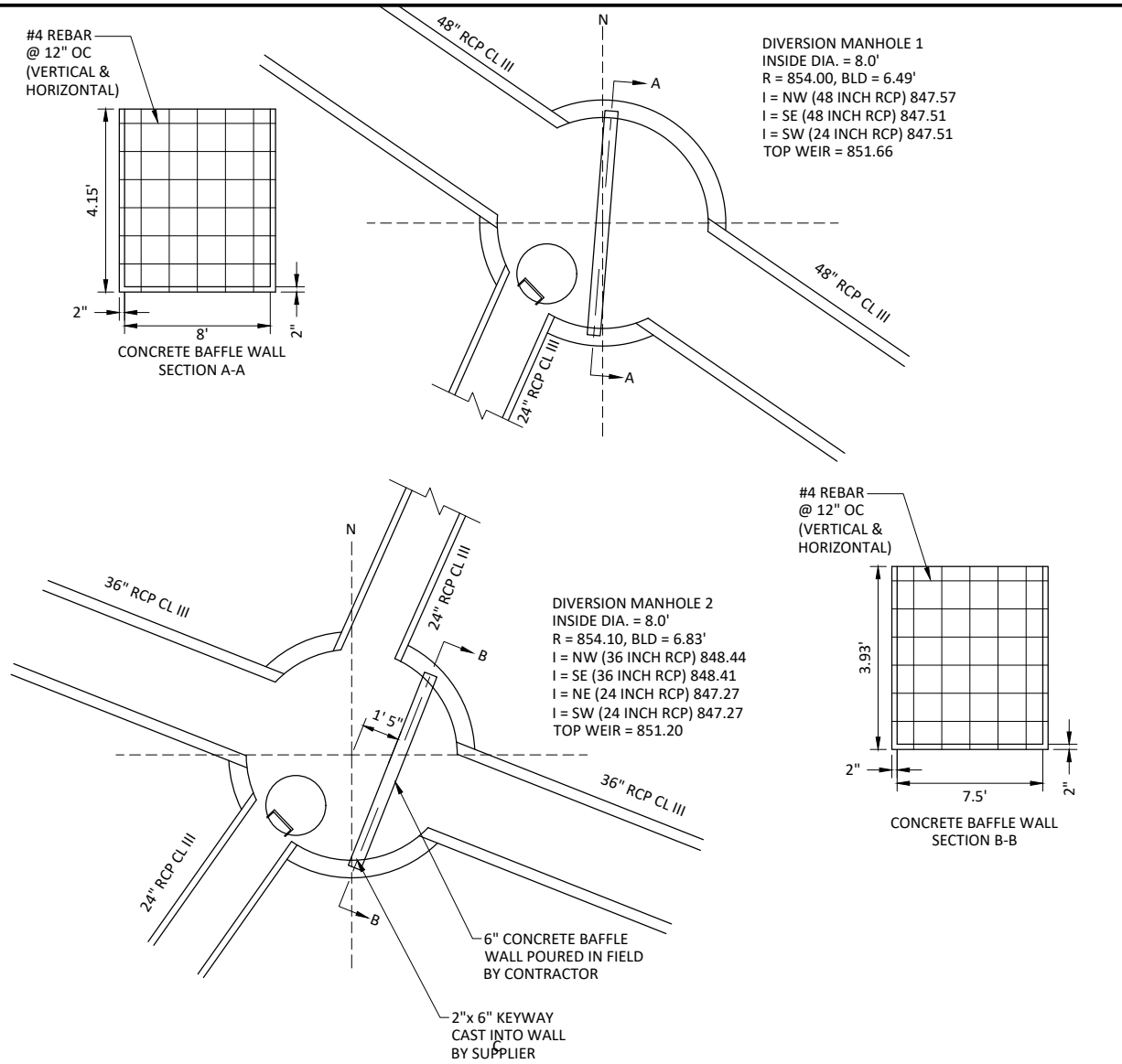
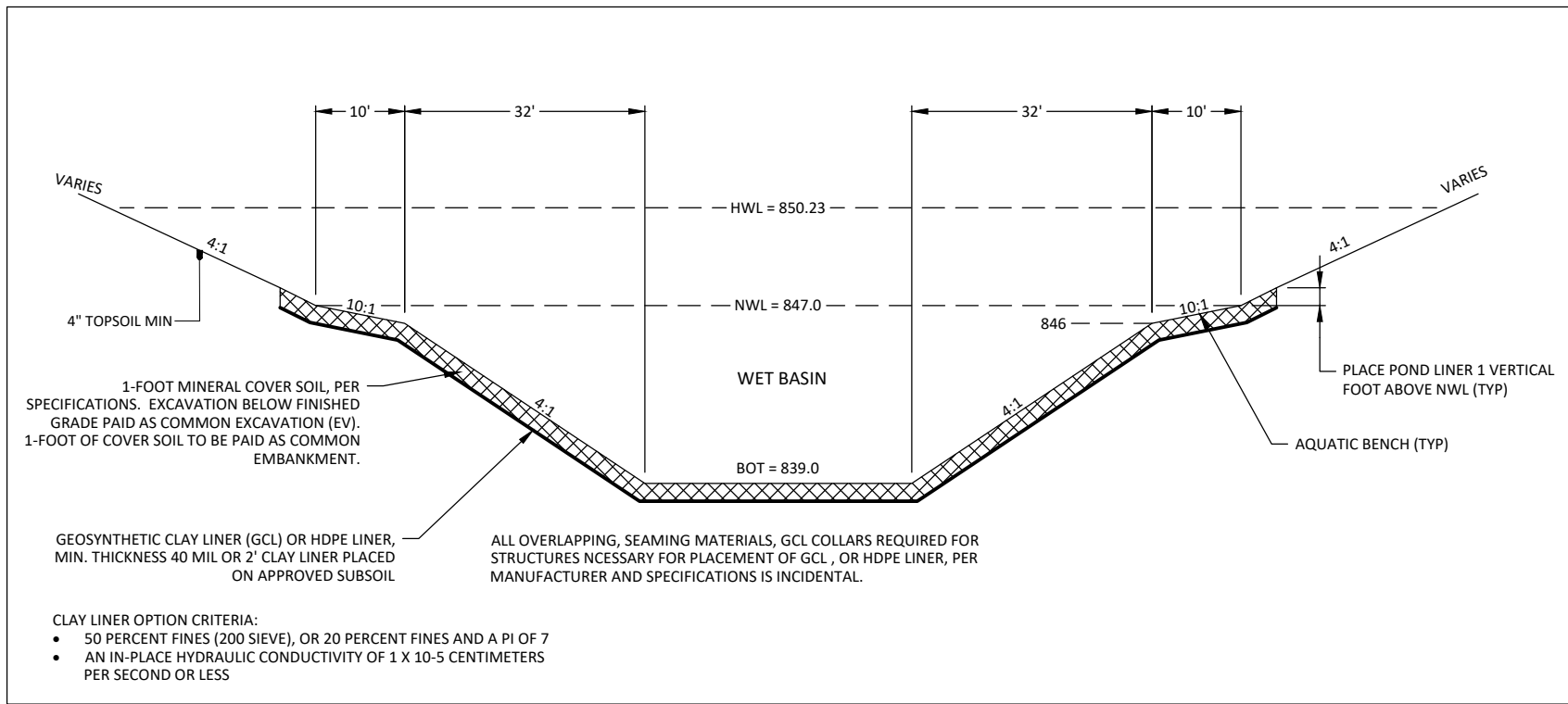

© Bolton & Menk, Inc. 2024. All Rights Reserved. 4/14/2024 10:41:53 AM C:\3D\3149\3149.G01.dwg 8/20/2024 4:05:09 PM

I HEREBY CERTIFY THAT THIS PLAN, SPECIFICATION, OR REPORT WAS PREPARED BY ME OR UNDER MY DIRECT SUPERVISION AND THAT I AM A DULY LICENSED PROFESSIONAL ENGINEER UNDER THE LAWS OF THE STATE OF MINNESOTA.

Kevin P. Kiehl
KEVIN P. KIELB
LIC. NO. 23211 DATE 8/20/2024



7533 SUNWOOD DR NW, SUITE 206
RAMSEY, MN 55303
Phone: (763) 433-2851
Email: Ramsey@bolton-menk.com
www.bolton-menk.com



DESIGNED	NO.	ISSUED FOR	DATE
ZFL			
DRAWN			
TJH			
CHECKED			
KPK			
CLIENT PROJ. NO.			
CP-25-01			

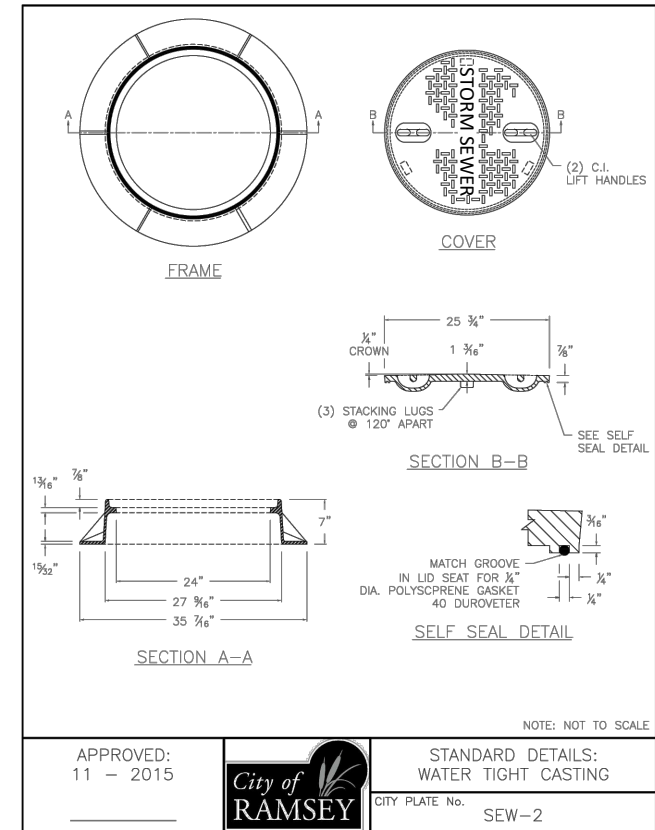
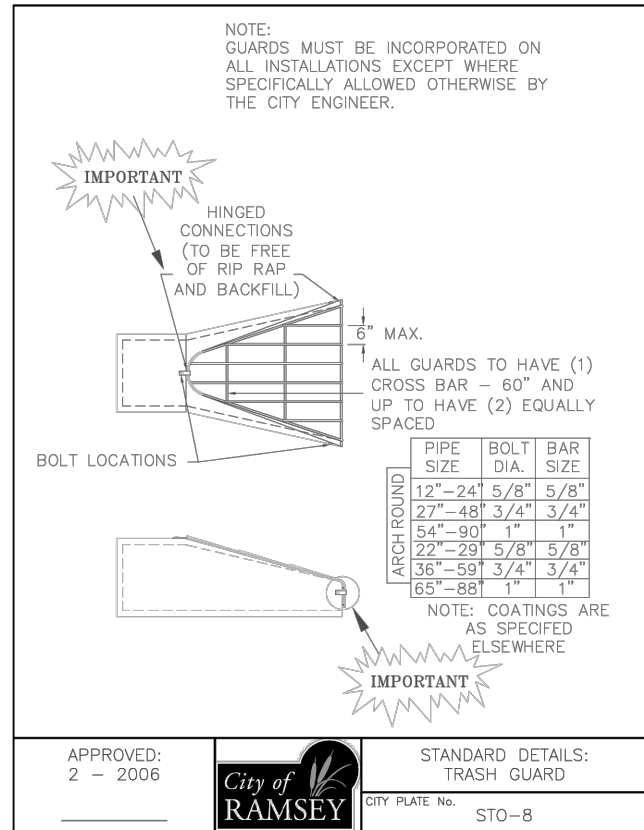
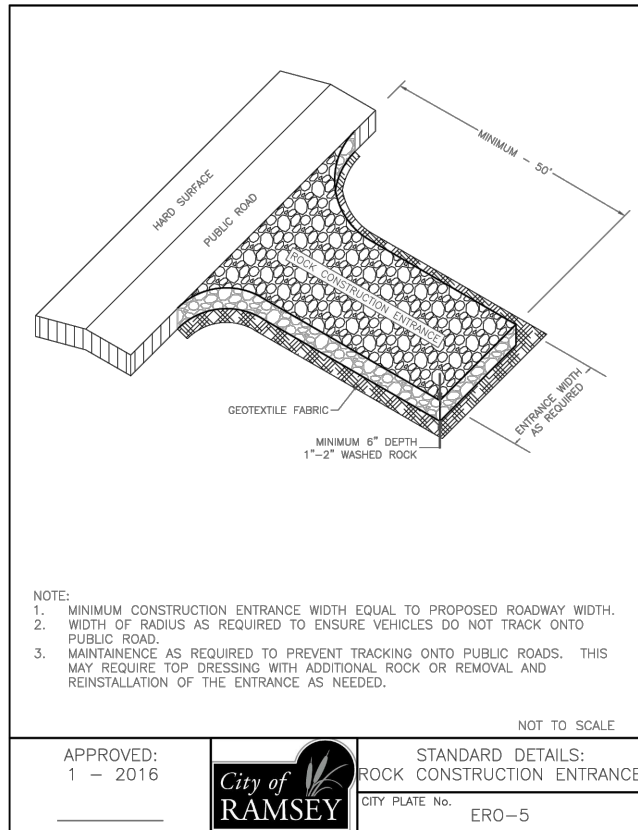
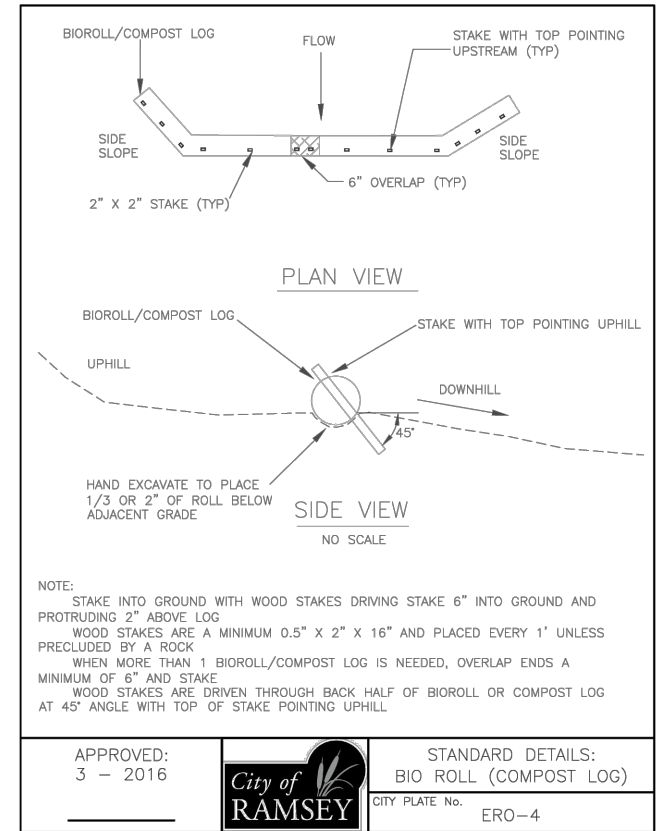
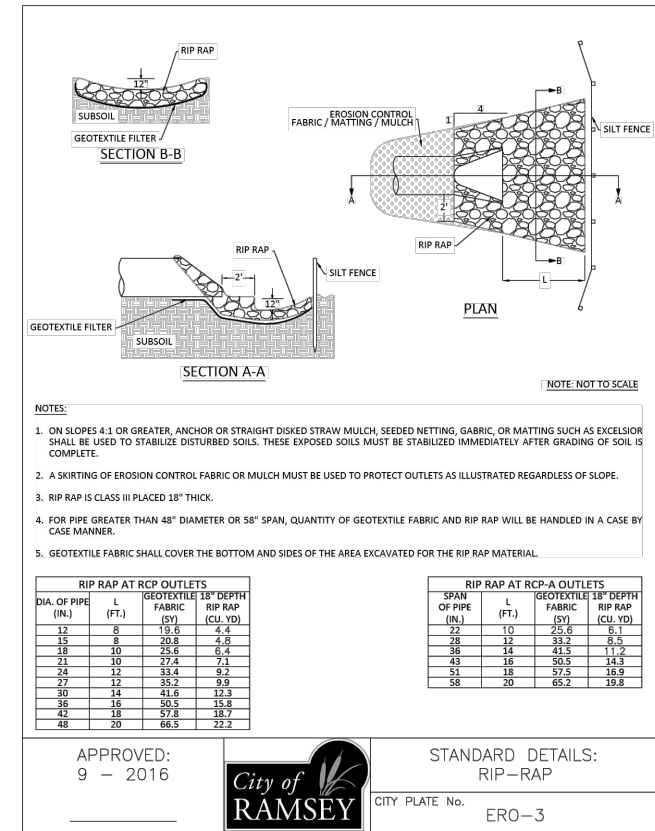
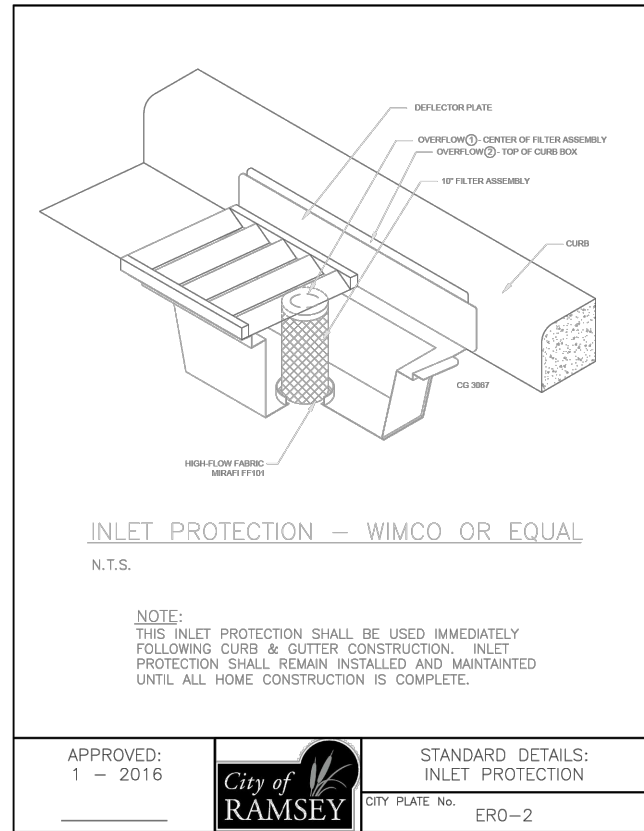
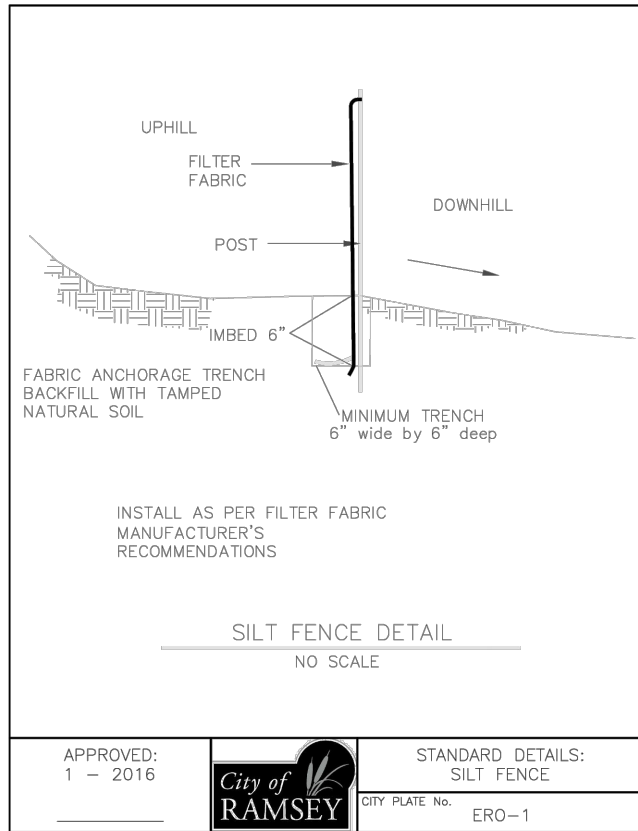

© Bolton & Menk, Inc. 2024. All Rights Reserved. P:\RAMSEY\2024\13159500\CAD\CSD\13159500.dwg, 8/20/2024, 4:05:10 PM

I HEREBY CERTIFY THAT THIS PLAN, SPECIFICATION, OR REPORT WAS PREPARED BY ME OR UNDER MY DIRECT SUPERVISION AND THAT I AM A DULY LICENSED PROFESSIONAL ENGINEER UNDER THE LAWS OF THE STATE OF MINNESOTA.

Kevin P. Kiehl
KEVIN P. KIELB
LIC. NO. 23211 DATE 8/20/2024



7533 SUNWOOD DR NW, SUITE 206
RAMSEY, MN 55303
Phone: (763) 433-2851
Email: Ramsey@bolton-menk.com
www.bolton-menk.com



DESIGNED	NO.	ISSUED FOR	DATE
ZFL			
DRAWN	TJH		
CHECKED	KPK		
CLIENT PROJ. NO.	CP-25-01		

CITY OF RAMSEY, MINNESOTA
RIVERS BEND REGIONAL STORMWATER IMPROVEMENTS
DETAILS

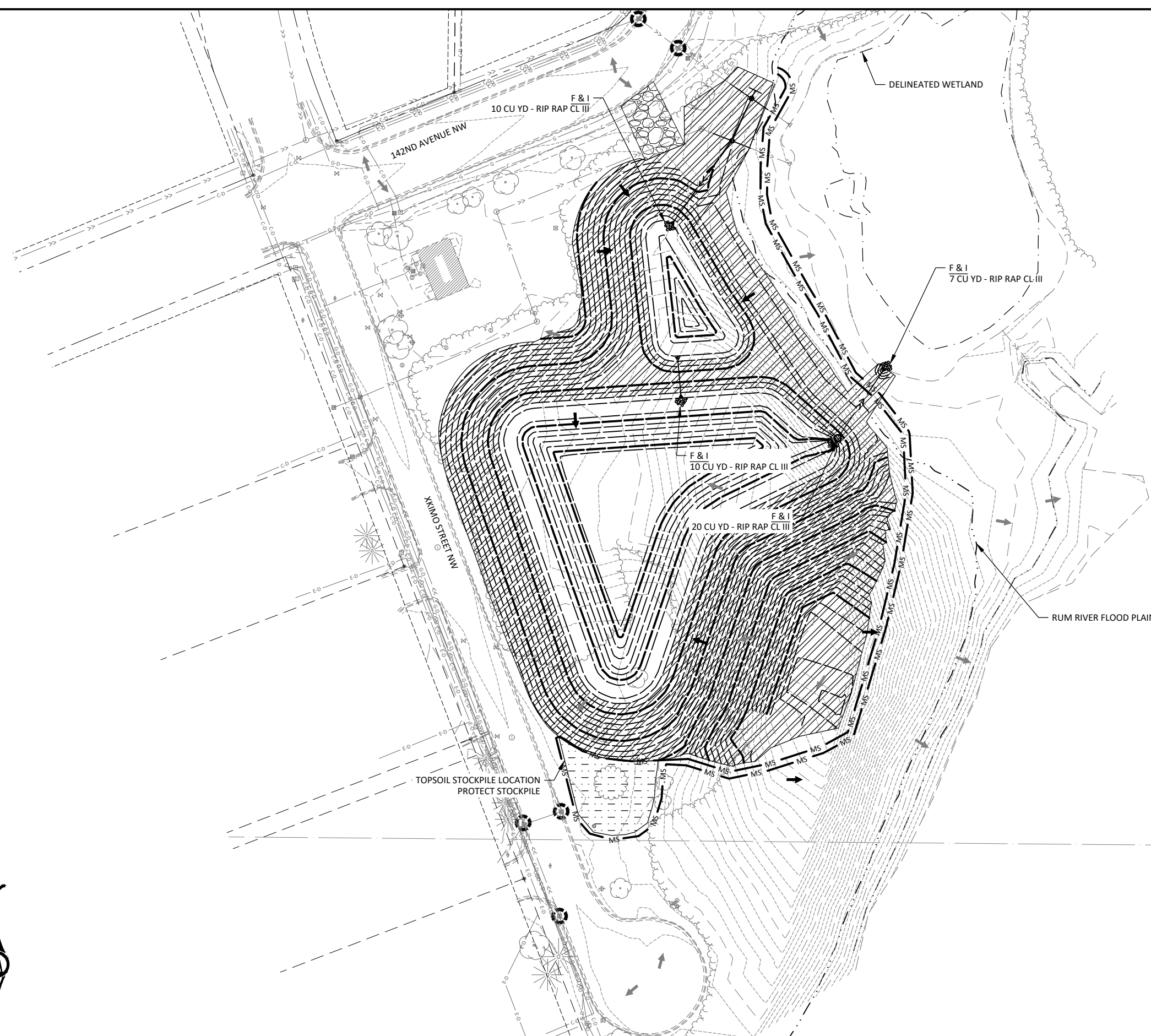

EROSION CONTROL LEGEND

	STORM DRAIN INLET PROTECTION
	SILT FENCE - MACHINE SLICED
	RIP RAP CLASS III
	PROPOSED DRAINAGE FLOW
	EXISTING DRAINAGE FLOW
	ROLLED EROSION PREVENTION CATEGORY 20 AND SEED MIX 35-241
	HYDRAULIC BONDED FIBER MATRIX
	STABILIZED CONSTRUCTION EXIT

- NOTES:**
1. ALL CATCH BASINS AND INLETS, BOTH EXISTING AND PROPOSED, SHALL HAVE INLET PROTECTION INSTALLED PRIOR TO DISTURBANCE AND REMAIN IN PLACE UNTIL CONSTRUCTION IS COMPLETED.
 2. CONSTRUCT STABILIZED CONSTRUCTION EXITS AS NECESSARY THROUGHOUT THE PROJECT.
 3. QUANTITY FOR INLET PROTECTION IS BASED ON INLET PROTECTION NEEDED FOR EACH STRUCTURE DURING THE COURSE OF THE PROJECT. ONCE STARTED, STORM SEWER AND GRADING ACTIVITIES SHALL BE EXECUTED DILIGENTLY AND CONTINUOUSLY UNTIL COMPLETE.
 4. PLACE 4" OF TOPSOIL IN OFF STREET GREEN SPACE.
 5. THE CONTRACTOR SHALL USE ONSITE TOPSOIL STOCKPILE FOR TOPSOIL INSTALLATION. NO TOPSOIL SHALL BE IMPORTED WITHOUT APPROVAL FROM THE ENGINEER.
 6. STABILIZE TOPSOIL STOCKPILE WITH HYDRAULIC BONDED FIBER MATRIX AT THE DIRECTION OF THE ENGINEER IN THE FIELD.

© Bolton & Menk, Inc. 2024. All Rights Reserved. P:\MINN3\24\1315960\CAD\C3D\C3D1315960.dwg, 8/20/2024, 4:05:19 PM

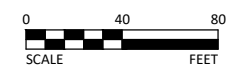
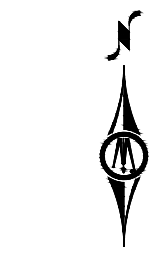

I HEREBY CERTIFY THAT THIS PLAN, SPECIFICATION, OR REPORT WAS PREPARED BY ME OR UNDER MY DIRECT SUPERVISION AND THAT I AM A DULY LICENSED PROFESSIONAL ENGINEER UNDER THE LAWS OF THE STATE OF MINNESOTA.

Kevin P. Kielb
 KEVIN P. KIELB
 LIC. NO. 23211 DATE 8/20/2024



7533 SUNWOOD DR NW, SUITE 206
 RAMSEY, MN 55303
 Phone: (763) 433-2851
 Email: Ramsey@bolton-menk.com
 www.bolton-menk.com



DESIGNED	NO.	ISSUED FOR	DATE
ZFL			
DRAWN			
TJH			
CHECKED			
KPK			
CLIENT PROJ. NO.			
CP-25-01			

CITY OF RAMSEY, MINNESOTA
 RIVERS BEND REGIONAL STORMWATER IMPROVEMENTS
 EROSION CONTROL & TURF ESTABLISHMENT

STORMWATER POLLUTION PREVENTION PLAN (SWPPP)

Rivers Bend Pond -2024
CITY OF Ramsey
Anoka COUNTY, MINNESOTA

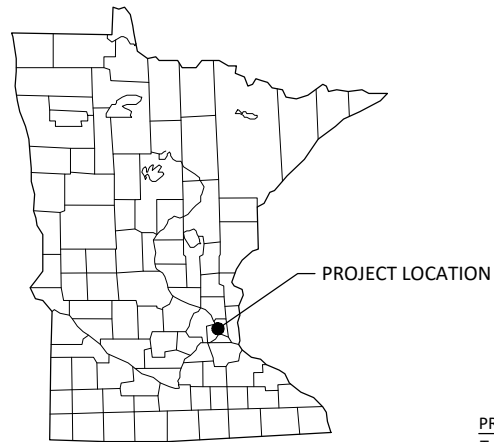

LEGEND

- PROJECT LOCATION
- 1-MILE BOUNDARY
- IMPAIRED, SPECIAL OR PROTECTED WATERS
- NATIONAL WETLANDS INVENTORY
- RECEIVING WATERS

PROJECT AREAS:

Total Project Size (disturbed area) =	2.8	ACRES
Existing area of impervious surface =	0	ACRES
Post construction area of impervious surface =	0	ACRES
Total new impervious surface area created =	0	ACRES

Planned Construction Start Date:	9/15/2024
Estimated Construction Completion Date:	11/15/2024

PERMANENT STORMWATER MANAGEMENT SYSTEM:

Type of storm water management used if more than 1 acre of new impervious surface is created:

1	Wet Sedimentation Basin
	Infiltration/Filtration
	Regional Pond
	Permanent Stormwater Management Not Required

PROJECT LOCATION:

COUNTY	TOWNSHIP	RANGE	SECTION	LATITUDE	LONGITUDE
ANOKA	T32N	R25W	25	45.22821°	-93.39473°

BMP SUMMARY	QUANTITY	UNIT
STORM DRAIN INLET PROTECTION	5	EACH
ROLLED EROSION PREVENTION CATEGORY 20	8,500	SQ YD
SEEDING MIXTURE 35-241	70	POUND
SILT FENCE MACHINE SLICED	1,800	LIN FT
RIP RAP CLASS III	50	CU YD
STABILIZED CONSTRUCTION EXIT	1	EACH

DESCRIPTION OF CONSTRUCTION ACTIVITIES AND STORMWATER MANAGEMENT:

Construction activities include: Site grading, sanitary sewer and water main extensions, temporary erosion and sediment control, and permanent stabilization.

Storm water currently from the urbanized and undeveloped area is currently being routed to catch basins located along 142nd Ave NW and Xkimo St. NW and flow through storm drains into an existing pond located within Rivers Bend park. The existing pond is located south of 142nd Ave NW and Waco st. NW intersection. The outlet of the pond is Rum River. The current pond size is in adequate to treat the current impervious area.

After construction is complete storm water will be managed in a different pond area. The water will be routed through the catch basins located on 142nd Ave. NW and Xkimo ST. NW and then routed through storm drains to the new biofiltration pond. First entering a wet sedimentation basin with a capacity of 74,000 cubic feet, 5 feet deep, then entering the biofiltration basin. The pond will have a treatment capacity of 148,795 cubic feet.

This project includes the following stormwater management BMPs: Biofiltration and wet sedimentation.

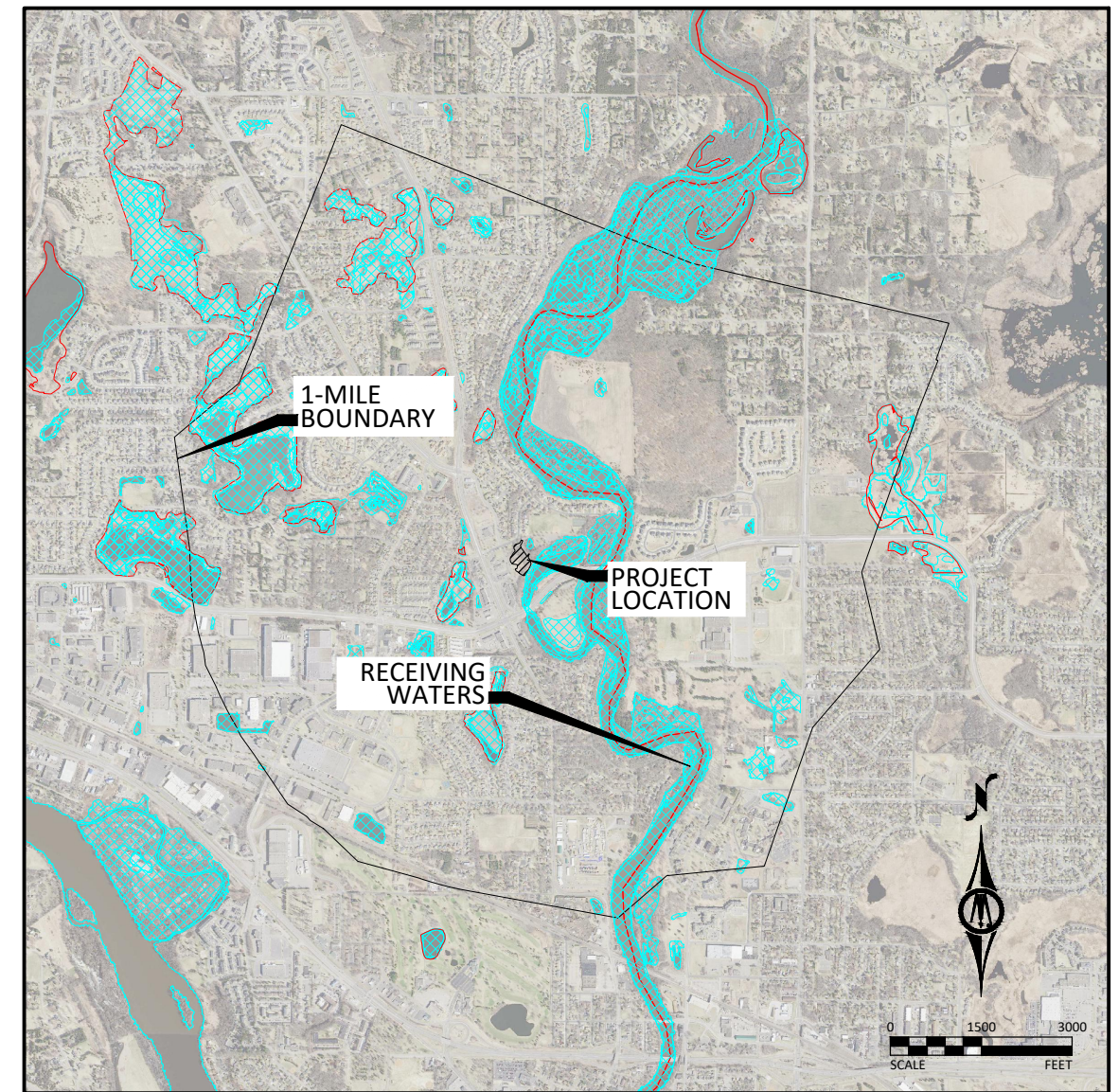

RECEIVING WATERS:

Receiving waters, including surface water, wetlands, Public Waters, and stormwater ponds, within 1-mile of the project boundary are identified on the USGS 7.5 min quad map above. Receiving waters that are impaired, the impairment, and WLA are listed as follows. All specific BMPs relative to construction activities listed in the permit for special, prohibited, restricted, or impaired have been incorporated into this plan. All specific BMPs listed in approved TMDLs and those BMPs listed for construction related waste load allocations have also been incorporated.

NAME OF WATER BODY	TYPE (ditch, pond, wetland, lake, etc.)	Special, Prohibited, Restricted Water ¹	Flows to Impaired Water Within 1-Mile ²	USEPA Approved Construction Related TMDL ³
Rum River	River	Nutrients	Yes	NaN

¹ Special, prohibited, and restricted waters are listed in Section 23 of the MN Construction Stormwater General Permit (MNR100001).

² Identified as impaired under section 303 (d) of the federal Clean Water Act for phosphorus, turbidity, TSS, dissolved oxygen, and/or aquatic biota.

³ Construction Related TMDLs include those related to: phosphorus, turbidity, TSS, dissolved oxygen, and/or aquatic biota.

IMPLEMENTATION SCHEDULE AND PHASING: The Contractor is required to provide an updated schedule and site management plan meeting the minimum requirements of Section 1717 of the Minnesota Standard Specifications for Construction.

- 1) Submit SWPPP Updates to Engineer. Submittal shall include any requested changes to the SWPPP, including but not limited to: Trained Personnel, Locations for Stockpiles, Concrete Washout, Sanitation Facilities, Types and Locations of Erosion & Sediment Control. Failure to submit updates shall be considered acceptance of the SWPPP as designed with no changes.
- 2) Install perimeter sediment control, inlet protection, and construction exit.
- 3) Complete Site Grading.
- 4) Add additional temporary BMPs as necessary during construction based on inspection reports.
- 5) Ensure final stabilization measures are complete.
- 6) Provide digital copy of all Field SWPPP Documentation including Inspection Reports and SWPPP Revisions to the Owner.
- 7) Submit Notice of Termination (NOT) to MPCA. NOTE: The NOT must be submitted to MPCA before Final Stabilization is considered complete.

RESPONSIBLE PARTIES:

The Contractor and Owner will be joint applicants under the MPCA's General Stormwater Permit for Construction Activity as required by the National Pollutant Discharge Elimination System (NPDES) Phase II program.

The Contractor shall provide one or more trained Construction SWPPP Manager(s) knowledgeable and experienced in the application of erosion prevention and sediment control BMPs that will oversee the implementation of the SWPPP, and the installation, inspection and maintenance of the erosion prevention and sediment control BMPs.

A Construction SWPPP Manager must be available for an on-site inspection within 72 hours upon request by the MPCA.

	COMPANY	CONTACT PERSON	PHONE
OWNER:	City of Ramsey	Bruce Westby, PE	763-433-9825
SWPPP DESIGNER:	Bolton & Menk, Inc.	Timothy Haugo	763-433-2851
CONTRACTOR:	TBD	TBD	TBD
CONSTRUCTION SWPPP MANAGER:	TBD	TBD	TBD
PARTY RESPONSIBLE FOR LONG TERM O&M:	City of Ramsey	Bruce Westby, PE	763-433-9825

The SWPPP Designer, Construction SWPPP Manager, and BMP Installer must have appropriate training. Documentation showing training commensurate with the job duties and responsibilities is required to be included in the SWPPP prior to any work beginning on the site. Training documentation for the SWPPP Designer is included on the Narrative sheet. The Contractor shall attach training documentation to this SWPPP for the Construction SWPPP Manager and BMP Installer prior to the start of construction. This information shall be kept up to date until the project NOT is filed.

ADDITIONAL COMPENSATION

Payment for all work associated with Erosion and Sediment Control shall be as described in the Project Manual. Unless otherwise authorized by the Owner no additional payment shall be made for any work required to administer and maintain the site erosion and sediment control in compliance with the Minnesota Pollution Control Agency (MPCA) - General Stormwater Permit for Construction Activity (MN R100001) including but not limited to inspection, maintenance, and removal of BMPs or addition of BMPs to accommodate Contractor phasing.

DOCUMENT RETENTION

Permittees must make the SWPPP, including all inspection reports, maintenance records, training records and other information required by this permit, available to federal, state, and local officials within three (3) days upon request for the duration of the permit and for three (3) years following the NOT.

GENERAL STORMWATER DISCHARGE REQUIREMENTS

All requirements listed in Section 5.1 of the Permit for the design of the permanent stormwater management system and discharge have been included in the preparation of this SWPPP. These include but are not limited to:

1. The expected amount, frequency, intensity, and duration of precipitation.
2. The nature of stormwater runoff and run-on at the site
3. Peak flow rates and stormwater volumes to minimize erosion at outlets and downstream channel and stream bank erosion.
4. The range of soil particle sizes expected to be present on the site.

Permanent stormwater treatment systems for this project have been designed in accordance with the guidance in the MN Stormwater Manual in place at the time of bidding. Copies of the design information and calculations are part of this SWPPP and will be provided in digital format upon written request to the Engineer.

© Bolton & Menk, Inc. 2024. All Rights Reserved. PROJECT: MPCA MAP.dwg, 8/20/2024, 4:06:29 PM

I HEREBY CERTIFY THAT THIS PLAN, SPECIFICATION, OR REPORT WAS PREPARED BY ME OR UNDER MY DIRECT SUPERVISION AND THAT I AM A DULY LICENSED PROFESSIONAL ENGINEER UNDER THE LAWS OF THE STATE OF MINNESOTA.

Kevin P. Kiehl
KEVIN P. KIELB
LIC. NO. 23211 DATE 8/20/2024



7533 SUNWOOD DR NW, SUITE 206
RAMSEY, MN 55303
Phone: (763) 433-2851
Email: Ramsey@bolton-menk.com
www.bolton-menk.com

DESIGNED	NO.	ISSUED FOR	DATE
ZFL			
DRAWN			
TJH			
CHECKED			
KPK			
CLIENT PROJ. NO.			
CP-25-01			

CITY OF RAMSEY, MINNESOTA
RIVERS BEND REGIONAL STORMWATER IMPROVEMENTS
STORM WATER POLLUTION PREVENTION PLAN

SHEET
8
OF
12

Information contained in this SWPPP narrative sheet summarizes requirements of the GENERAL PERMIT AUTHORIZATION TO DISCHARGE STORMWATER ASSOCIATED WITH CONSTRUCTION ACTIVITY UNDER THE NATIONAL POLLUTANT DISCHARGE ELIMINATION SYSTEM/STATE DISPOSAL SYSTEM PROGRAM - Permit No: MN R100001 (Permit) as they apply to this project. All provisions of the Permit including those not specifically cited herein shall apply to this project. The Contractor is responsible to be familiar with and comply with all conditions of the permit. The full text of the Permit is available at: <https://www.pca.state.mn.us/sites/default/files/wq-strm2-80a.pdf>

SWPPP AMENDMENTS AND SUBMITTALS

Contractor must prepare and submit to the Engineer a SWPPP amendment as necessary to include additional Best Management Practices (BMPs) to correct problems identified or address the following situations.

1. Contact information and training documentation for Construction SWPPP Manager and BMP Installer,
2. There is a change in construction method of phasing, operation, maintenance, weather or seasonal conditions not anticipated during the design of the SWPPP including but not limited to:
 - a. Types and/or Locations of BMPs
 - b. Material Storage and Spill Response
 - c. Fueling Plans
 - d. Locations for Stockpiles, Concrete Washout, and Sanitation Facilities and
 - e. Project Phasing
3. It is determined that the SWPPP is not achieving objectives of minimizing pollutants in stormwater discharges associated with construction activity, or
4. The SWPPP is not consistent with the terms and conditions of the permit.

The Contractor may implement SWPPP amendments immediately and is not required to wait for Engineer review of the submittal. The responsibility for completeness of SWPPP amendments and compliance with the Permit lies with the Contractor. Review, comment, or lack of comment by the Engineer on a SWPPP amendment shall not absolve the responsibilities of the Contractor in any way.

If a change order is issued for a design change the SWPPP amendment will be prepared by the Engineer and included in the change order.

In addition to SWPPP amendments, the Contractor shall submit to the Engineer Weekly Erosion and Sediment Control Schedule meeting the requirements of MnDOT 1717.

The Contractor shall keep copies of all SWPPP amendments, Weekly Erosion and Sediment Control Schedules, inspection logs, and maintenance logs with the field copy of the SWPPP. A PDF copy of these documents will be provided along with a copy of the final Field Copy of the SWPPP to the Engineer along with the signed Notice of Termination when final stabilization is complete.

EROSION PREVENTION PRACTICES

Stormwater conveyance channels shall be routed around unstabilized areas. Erosion controls and velocity dissipation devices shall be used at outlets within and along the length of any constructed conveyance channel.

The normal wetted perimeter of all ditches or swales, including storm water management pond slopes, that drain waters from the site must be stabilized within 200' of any property edge or discharge point, including storm sewer inlets, within 24 hours of connection.

Temporary or permanent ditches or swales used as sediment containment during construction do not need to be stabilized during temporary period of use and shall be stabilized within 24 hours after no longer used as sediment containment.

Mulch, hydromulch, tackifier, or similar practice shall not be used in any portion of the wetted perimeter of a temporary or permanent drainage ditch or swale section with a continuous slope of greater than 2 percent.

Energy dissipation shall be installed at all temporary or permanent pipe outlets within 24 hours of connection to a surface water or permanent stormwater treatment system.

The Contractor shall phase construction and use construction methods to the extent practical to minimize exposed soils. The project phasing shall be documented in the Weekly Erosion and Sediment Control Schedule.

SEDIMENT CONTROL PRACTICES

Down gradient BMPs including perimeter BMPs must be in place before up gradient land- disturbing activities begin and shall remain in place until final stabilization.

All BMPs that have been adjusted or removed to accommodate short-term activities shall be re-installed or replaced the earlier of the end of the work day or before the next precipitation event even if the activity is not complete.

Inlet BMPs may be removed for specific safety concerns. The BMPs shall be replaced as soon as the safety concern is resolved. The removal shall be documented in the SWPPP as a SWPPP amendment.

Temporary stockpiles must have sediment control BMPs. The Contractor shall prepare and submit to the Engineer a SWPPP amendment showing the location of temporary stockpiles and the BMPs for each stockpile. The SWPPP amendment must meet the minimum requirements of Section 9 of the Permit.

Soil compaction shall be minimized and topsoil shall be preserved, unless infeasible or if construction activities dictate soil compaction or topsoil stripping.

The use of polymers, flocculants, or other sedimentation treatment chemicals are not proposed as part of this SWPPP as designed by the Engineer. If methods or phasing of construction require the use of any of these chemicals, the Contractor shall prepare and submit to the Engineer a SWPPP amendment that meets the minimum requirements of Section 9 of the Permit.

TEMPORARY SEDIMENTATION BASINS

A temporary sedimentation basin has not been included in this SWPPP as designed by the Engineer. If a basin is later determined to be desirable or necessary the Contractor shall prepare and submit to the Engineer a SWPPP amendment. Temporary sedimentation basins shall meet or exceed the minimum requirements of Section 14 of the Permit and shall include a basin draining plan meeting or exceeding the minimum requirements of Section 10 of the Permit. Where the site discharges to Special and/or Impaired Waters the SWPPP amendment shall also meet or exceed the minimum requirements of Section 23 of the permit.

DEWATERING

A dewatering plan has not been included in this SWPPP as designed by the Engineer. If dewatering is required for this project, the Contractor shall prepare and submit to the Engineer a SWPPP amendment. All dewatering shall meet or exceed the minimum requirements of Section 10 of the Permit.

POLLUTION PREVENTION

Products and materials that have the potential to leach pollutants that are stored on the site must be stored in a manner designed to minimize contact with stormwater. Materials that are not a source of potential contamination to stormwater or that are designed for exposure to stormwater are not required to be covered.

Hazardous materials including but not limited to pesticides, fertilizer, petroleum products, curing compounds and toxic waste must be properly stored and protected from stormwater exposure as recommended by the manufacturer in an access restricted area.

Solid waste must be stored, collected and disposed of in compliance with Minnesota Administrative Rules Chapter 7035.

Portable toilets must be positioned so that they are secure and will not be tipped or knocked over. Sanitary waste must be disposed of properly in accordance with Minn. R. CH 7041.

Exterior vehicle or equipment washing on the project site shall be limited to a defined area of the site. No engine degreasing is allowed on site. A sign must be installed adjacent to each washout facility that requires site personnel to utilize the proper facilities for disposal of concrete and other washout wastes.

The Contractor shall prepare and submit a SWPPP amendment detailing the location and BMPs proposed for storage of materials, solid waste, portable toilets, and exterior vehicle or equipment washing on the site. The SWPPP amendment shall include a spill prevention and response plan that is appropriate for the materials proposed to be on the site. The SWPPP amendment shall meet or exceed the minimum requirements of Section 12 of the Permit.

INSPECTION & MAINTENANCE

A trained person shall routinely inspect the entire construction site at the time interval indicated on this sheet of the SWPPP during active construction and within 24-hours after a rainfall event greater than 0.5 inches in 24 hours. Following an inspection that occurs within 24-hours after a rainfall event, the next inspection must be conducted at the time interval indicated in the Receiving Waters Table found on the SITE PLAN AND INFORMATION SHEET of the SWPPP.

All inspections and maintenance conducted during construction must be recorded on the day it is completed and must be retained with the SWPPP. Inspection report forms are available in the Project Specifications. Inspection report forms other than those provided shall be approved by the engineer.

The Contractor may request a change in inspection schedule for the following conditions:

- a. Inspections of areas with permanent cover to be reduced to once per month,
- b. Inspections of areas that have permanent cover and have had no construction activity for 12 months to be suspended until construction resumes,
- c. Inspections of areas where construction is suspended due to frozen ground conditions, inspections to be suspended until the earlier of within 24 hours of runoff occurring, or upon resuming construction.

No change in inspection schedule shall occur until authorized by the Engineer.

Inspections must include:

1. All erosion prevention and sediment control BMPs and Pollution Prevention Management Measures to ensure integrity and effectiveness.
2. Surface waters, including drainage ditches and conveyance systems for evidence of erosion and sediment deposition.
3. Construction site vehicle exit locations, streets and curb and gutter systems within and adjacent to the project for sedimentation from erosion or tracked sediment from vehicles.
4. Infiltration areas to ensure that no sediment from ongoing construction activity is reaching the infiltration area and that equipment is not being driven across the infiltration area.

All non-functioning BMPs and those BMPs where sediment reaches one-half (1/2) of the depth of the BMP, or in the case of sediment basins one-half (1/2) of the storage volume, must be repaired, replaced, or supplemented by the end of the next business day after discovery, or as soon as field conditions allow.

Permittees must repair, replace or supplement all nonfunctional BMPs with functional BMPs by the end of the next business day after discovery, or as soon as field conditions allow.

Any sediment that escapes the site must be removed and the area stabilized within 7 calendar days of discovery unless precluded by legal, regulatory, or physical access in which case the work shall be completed within 7 calendar days of authorization. Paved surfaces such as streets shall have any escaped or tracked sediment removed by the end of the day that it is discovered. Sediment release, other than paved surfaces that can be cleaned up with street sweeping shall be reported immediately upon discovery to the Engineer.

PUBLIC WATER RESTRICTIONS:

For public waters that have been promulgated "work in water restrictions" during fish spawning time frames, all exposed soil areas that are within 200 feet of the water's edge, and drain to these waters must complete stabilization within 24-hours during the time period. MN DNR permits are not valid for work in waters that are designated as infested waters unless accompanied by an Infested Waters Permit or written notification has been obtained from MN DNR stating that such permit is not required. There is no exception for pre-existing permits. If a MN DNR Permit has been issued for the project and the water is later designated as infested, the Contractor shall halt all work covered by the MN DNR Permit until an Infested Waters Permit is obtained or that written notification is obtained stating that such permit is not required.

FINAL STABILIZATION

Final Stabilization is not complete until all the following requirements have been met:

1. Substantial Completion has been reached and no ground disturbing activities are anticipated.
2. Permanent cover has been installed with an established minimum uniform perennial vegetation density of 70 percent of its expected final growth. Vegetation is not required in areas where no vegetation is proposed by this project such as impervious surfaces or the base of a sand filter.

3. Accumulated sediment has been removed from all permanent stormwater treatment systems as necessary to ensure the system is operating as designed.
4. All sediment has been removed from conveyance systems
5. All temporary synthetic erosion prevention and sediment control BMPs have been removed. BMPs designated on the SWPPP to remain to decompose on-site may remain.
6. For residential construction only, permit coverage terminates on individual lots if the structures are finished and temporary erosion prevention and downgradient perimeter control is complete, the residence sells to the homeowner, and the permittee distributes the MPCA's "Homeowner Fact Sheet" to the homeowner.
7. For agricultural land only (e.g., pipelines across cropland), the disturbed land must be returned to its preconstruction agricultural use prior to submitting the NOT.

SITE STABILIZATION COMPLETION:

Stabilization of exposed soils shall begin immediately and shall be completed after the construction activity has temporarily or permanently ceased no later than:	7 calendar days
--	-----------------

SITE INSPECTION INTERVAL:

A trained person shall routinely inspect the entire construction site during active construction at an interval of no more than:	7 calendar days
--	-----------------

SPECIAL ENVIRONMENTAL CONSIDERATIONS AND PERMITS:

1) Was an environmental review required for this project or any part of a common plan of development or sale that includes all or any portion of this project?	NO
2) Does any portion of the site have the potential to affect threatened or endangered species or their critical habitat?	NO
3) Does any portion of this site discharge to a Calcareous fen.	NO
4) Will any portion of the site potentially affect properties listed on the National Register of Historic Places or a known or discovered archeological site?	NO
5) Have any Karst features been identified in the project vicinity?	NO
6) Is compliance with temporary or permanent stormwater management design requirements infeasible for this project?	NO
7) Has the MN DNR promulgated "work in water restrictions" for any Public Water this site discharges to during fish spawning?	NO

TYPE OF PERMIT	PERMITTING AGENCY	PERMIT STATUS AND CONDITIONS
Construction Stormwater NPDES	MPCA	Contractor Obtained
Watershed	LRRWMO	In Progress
Dewatering	MnDNR	Contractor Obtained

SWPPP DESIGNER TRAINING DOCUMENTATION:

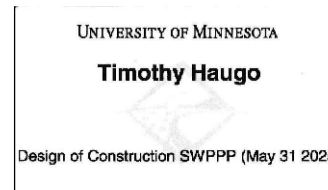

© Bolton & Menk, Inc. 2024. All Rights Reserved. \\RAMSEY\24413519560\CAD\CSD\13131924X SWPPP_1_PWD_INFO_MAP.dwg 8/20/2024 4:06:30 PM

I HEREBY CERTIFY THAT THIS PLAN, SPECIFICATION, OR REPORT WAS PREPARED BY ME OR UNDER MY DIRECT SUPERVISION AND THAT I AM A DULY LICENSED PROFESSIONAL ENGINEER UNDER THE LAWS OF THE STATE OF MINNESOTA.

 KEVIN P. KIELB
 LIC. NO. 23211 DATE 8/20/2024



7533 SUNWOOD DR NW, SUITE 206
 RAMSEY, MN 55303
 Phone: (763) 433-2851
 Email: Ramsey@bolton-menk.com
 www.bolton-menk.com



DESIGNED	NO.	ISSUED FOR	DATE
ZFL			
DRAWN			
TJH			
CHECKED			
KPK			
CLIENT PROJ. NO.			
CP-25-01			

CITY OF RAMSEY, MINNESOTA
 RIVERS BEND REGIONAL STORMWATER IMPROVEMENTS
 STORM WATER POLLUTION PREVENTION NARRATIVE

SHEET
 9
 OF
 12



LEGEND

-  PROJECT BOUNDARY
-  SOIL TYPE
-  STEEP SLOPES (>33.3%)

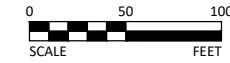

SOIL TYPE SUMMARY

Map Unit Symbol	Soil Name	Hyd. Soil Group
Ba	Becker	B
DnA	Dickman	A
NyC	Nymore	A

- NHEL - Not Highly Erodible Land
- PHEL - Potentially Highly Erodible Land
- HEL - Highly Erodible Land

LOCATION OF SWPPP REQUIREMENTS IN PROJECT PLAN

DESCRIPTION	SHEET NO.
SITE MAP	8
DIRECTION OF FLOW	8
FINAL STABILIZATION	8
SOILS	10
DRAINAGE STRUCTURES	11
STORM SEWER PLAN & PROFILE SHEETS	12
EROSION & SEDIMENT CONTROL DETAILS	8
NARRATIVE & NOTES	9

© Bolton & Menk, Inc. 2024. All Rights Reserved. \\NAMES\2024\13159200\CAD\CSD\13159200_SWPPP_3_SOILS.dwg 8/20/2024 4:06:40 PM

I HEREBY CERTIFY THAT THIS PLAN, SPECIFICATION, OR REPORT WAS PREPARED BY ME OR UNDER MY DIRECT SUPERVISION AND THAT I AM A DULY LICENSED PROFESSIONAL ENGINEER UNDER THE LAWS OF THE STATE OF MINNESOTA.

Kevin P. Kiehl
 KEVIN P. KIELB
 LIC. NO. 23211 DATE 8/20/2024



7533 SUNWOOD DR NW, SUITE 206
 RAMSEY, MN 55303
 Phone: (763) 433-2851
 Email: Ramsey@bolton-menk.com
 www.bolton-menk.com

DESIGNED	NO.	ISSUED FOR	DATE
ZFL			
TJH			
KPK			
CLIENT PROJ. NO.			
CP-25-01			

CITY OF RAMSEY, MINNESOTA
 RIVERS BEND REGIONAL STORMWATER IMPROVEMENTS
 STORM WATER POLLUTION PREVENTION SOILS

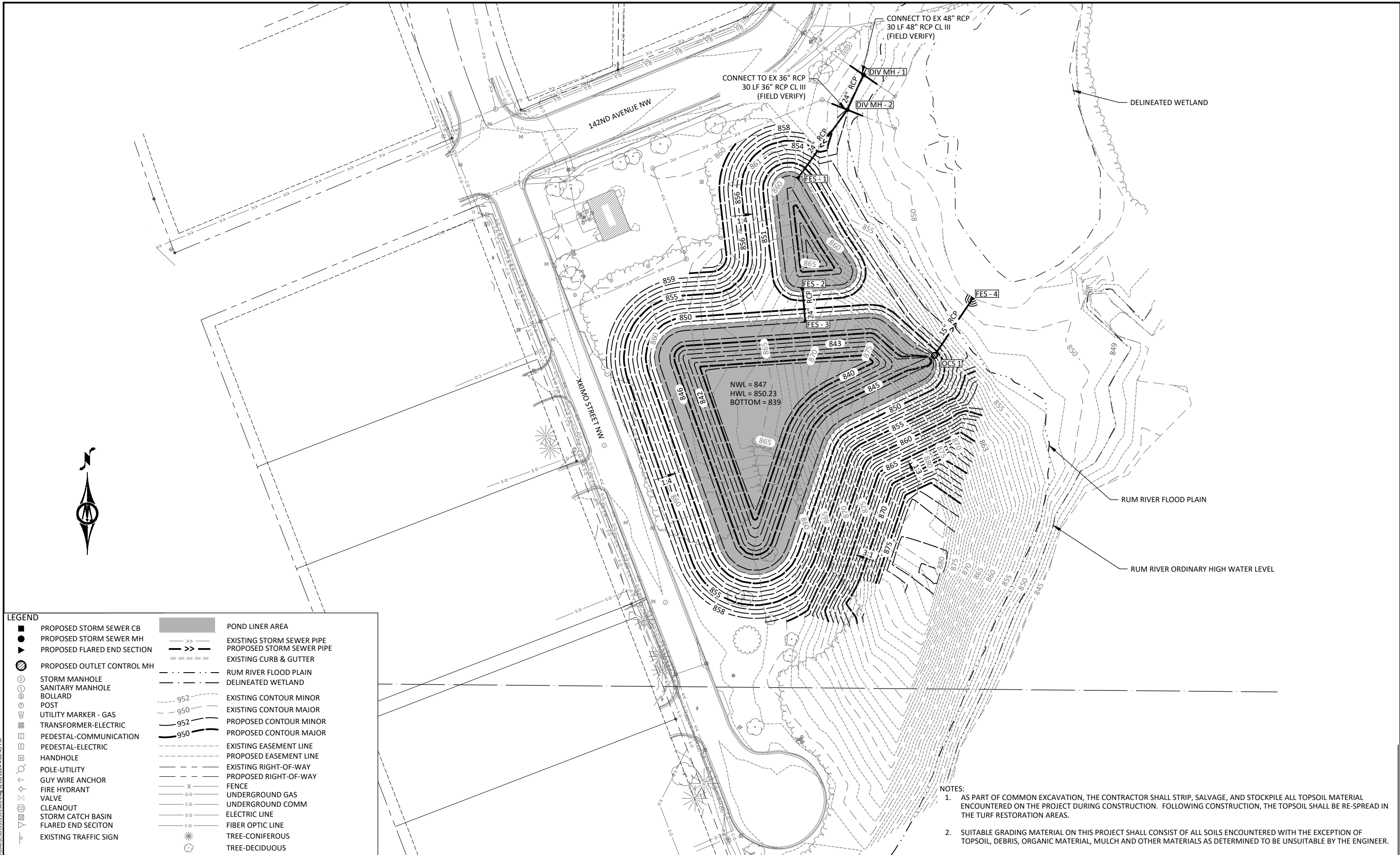

LEGEND

■	PROPOSED STORM SEWER CB	■	POND LINER AREA
●	PROPOSED STORM SEWER MH	— >> —	EXISTING STORM SEWER PIPE
▼	PROPOSED FLARED END SECTION	— >> —	PROPOSED STORM SEWER PIPE
⊙	PROPOSED OUTLET CONTROL MH	=====	EXISTING CURB & GUTTER
⊙	STORM MANHOLE	---	RUM RIVER FLOOD PLAIN
⊙	SANITARY MANHOLE	---	DELINEATED WETLAND
⊙	BOLLARD	--- 952 ---	EXISTING CONTOUR MINOR
⊙	POST	--- 950 ---	EXISTING CONTOUR MAJOR
⊙	UTILITY MARKER - GAS	--- 952 ---	PROPOSED CONTOUR MINOR
⊙	TRANSFORMER-ELECTRIC	--- 950 ---	PROPOSED CONTOUR MAJOR
⊙	PEDESTAL-COMMUNICATION	---	EXISTING EASEMENT LINE
⊙	PEDESTAL-ELECTRIC	---	PROPOSED EASEMENT LINE
⊙	HANDHOLE	---	EXISTING RIGHT-OF-WAY
⊙	POLE-UTILITY	---	PROPOSED RIGHT-OF-WAY
⊙	GUY WIRE ANCHOR	X	FENCE
⊙	FIRE HYDRANT	G-D	UNDERGROUND GAS
⊙	VALVE	C-D	UNDERGROUND COMM
⊙	CLEANOUT	E-D	ELECTRIC LINE
⊙	STORM CATCH BASIN	F-D	FIBER OPTIC LINE
⊙	FLARED END SECTION	⊙	TREE-CONIFEROUS
⊙	EXISTING TRAFFIC SIGN	⊙	TREE-DECIDUOUS

NOTES:

- AS PART OF COMMON EXCAVATION, THE CONTRACTOR SHALL STRIP, SALVAGE, AND STOCKPILE ALL TOPSOIL MATERIAL ENCOUNTERED ON THE PROJECT DURING CONSTRUCTION. FOLLOWING CONSTRUCTION, THE TOPSOIL SHALL BE RE-SPREAD IN THE TURF RESTORATION AREAS.
- SUITABLE GRADING MATERIAL ON THIS PROJECT SHALL CONSIST OF ALL SOILS ENCOUNTERED WITH THE EXCEPTION OF TOPSOIL, DEBRIS, ORGANIC MATERIAL, MULCH AND OTHER MATERIALS AS DETERMINED TO BE UNSUITABLE BY THE ENGINEER.

© Bolton & Menk, Inc. 2024. All Rights Reserved. P:\RAMSEY\2024\CP-25\20240820\CP-25-01.dwg, 8/20/2024, 4:05:49 PM

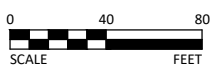

I HEREBY CERTIFY THAT THIS PLAN, SPECIFICATION, OR REPORT WAS PREPARED BY ME OR UNDER MY DIRECT SUPERVISION AND THAT I AM A DULY LICENSED PROFESSIONAL ENGINEER UNDER THE LAWS OF THE STATE OF MINNESOTA.

Kevin P. Kielb
 KEVIN P. KIELB
 LIC. NO. 23211 DATE 8/20/2024



7533 SUNWOOD DR NW, SUITE 206
 RAMSEY, MN 55303
 Phone: (763) 433-2851
 Email: Ramsey@bolton-menk.com
 www.bolton-menk.com



DESIGNED	NO.	ISSUED FOR	DATE
ZFL			
DRAWN			
TJH			
CHECKED			
KPK			
CLIENT PROJ. NO.			
CP-25-01			

CITY OF RAMSEY, MINNESOTA
 RIVERS BEND REGIONAL STORMWATER IMPROVEMENTS
 GRADING PLANS

SHEET 11 OF 12

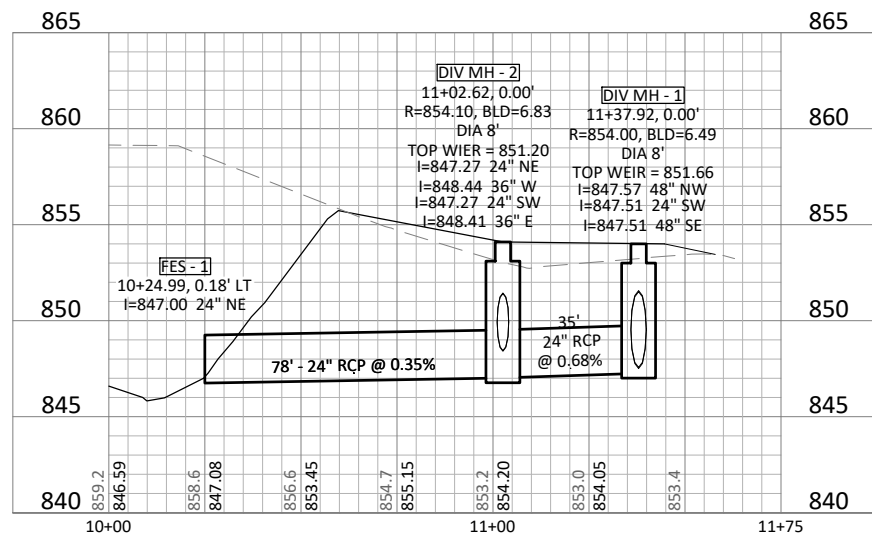

FES - 1 TO DIV MH - 1

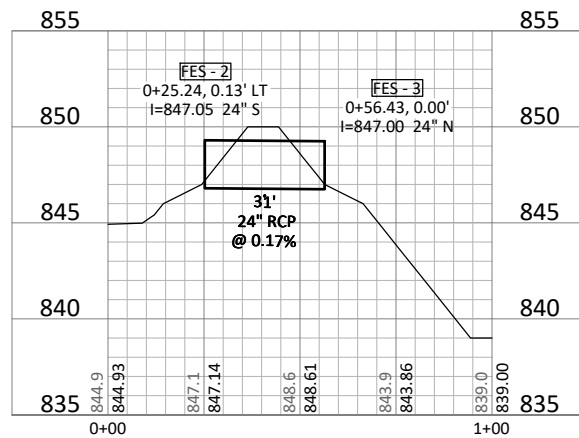

FES - 2 TO FES - 3

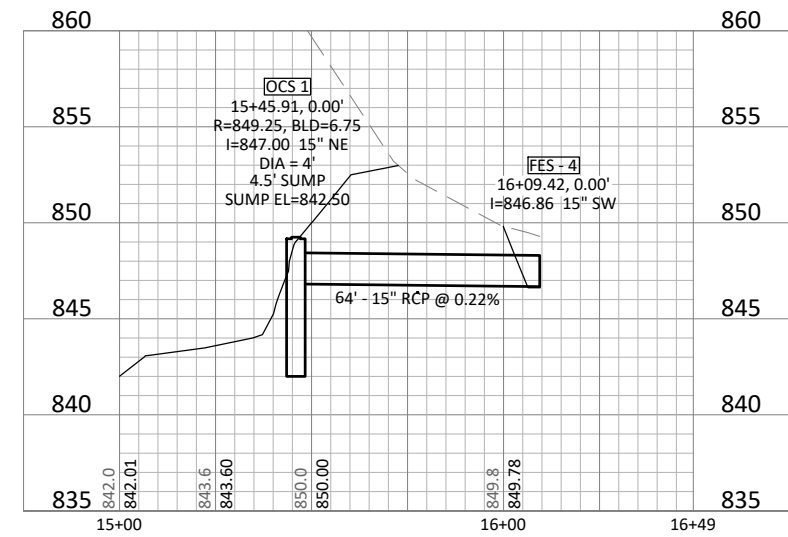

OCS 1 TO FES - 4

© Bolton & Menk, Inc. 2024. All Rights Reserved. 11/16/2024 1:53:56 PM CAD/CS/131319/CS01.dwg 8/20/2024 4:06:55 PM

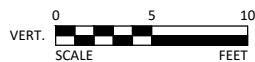
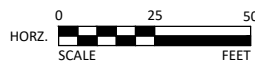

I HEREBY CERTIFY THAT THIS PLAN, SPECIFICATION, OR REPORT WAS PREPARED BY ME OR UNDER MY DIRECT SUPERVISION AND THAT I AM A DULY LICENSED PROFESSIONAL ENGINEER UNDER THE LAWS OF THE STATE OF MINNESOTA.

Kevin P. Kielb
KEVIN P. KIELB
LIC. NO. 23211 DATE 8/20/2024



7533 SUNWOOD DR NW, SUITE 206
RAMSEY, MN 55303
Phone: (763) 433-2851
Email: Ramsey@bolton-menk.com
www.bolton-menk.com



DESIGNED	NO.	ISSUED FOR	DATE
ZFL			
DRAWN			
TJH			
CHECKED			
KPK			
CLIENT PROJ. NO.			
CP-25-01			

CITY OF RAMSEY, MINNESOTA
RIVERS BEND REGIONAL STORMWATER IMPROVEMENTS
STORM SEWER PROFILES

SHEET 12 OF 12