

City of Ramsey
Agenda
Regular City Council
Tuesday, August 12, 2025
7:00 pm

Council Chambers, 7550 Sunwood Drive NW

Remote Attendance available at www.cityoframsey.com/meetings.
Those joining remotely and requesting to speak are asked to use a webcam when speaking.

1. Call to Order

2. Approve Agenda

3. Presentation

4. Citizen Input

Citizen input is an opportunity for the public to address the City Council concerning items not listed on the agenda. Please raise your hand to be recognized by the Mayor or member officiating the meeting. Approach the podium and state your full name and address for the record. Time may be limited.

5. Consent Agenda

All items listed under the Consent Agenda are considered to be routine or non-controversial by the City Council and will be enacted by one motion, without discussion.

1. Receive June 2025 Finance Reports - General Fund, EDA, and Enterprise Funds

2. Receive Cash and Investments for Period Ending July 31, 2025

3. Note the following Boards, Commissions and Meeting Minutes:

- Planning Commission Meeting Minutes - June 26, 2025
- Economic Development Authority - May 8, 2025
- Public Works Meeting Minutes - June 17, 2025
- Park and Rec Commission Meeting Minutes - June 12, 2025

4. Approve the Following Meeting Minutes:
 1. City Council Work Session dated July 22, 2025
 2. City Council Regular Session dated July 22, 2025

5. Approve Business License Applications

6. Approve Request to Declare Surplus Property

7. Adopt Resolution #25-182 Approving Cash Disbursements Made and Authorizing Payment of Accounts Payable Invoicing Received During the Period of July 17, 2025 through August 6, 2025.

8. Adopt Resolution #25-178 Approving a Development Agreement for CCI Holdings 2, LLC (14047 Auzrite St. NW)

9. Adopt Resolution #25-179 To Amend Joint Powers Agreement With North Metro Mayors Association

10. Adopt Resolution #25-180 Approving a Development Agreement for CCI Holdings 3, LLC (14310 Sunfish Lake Blvd. NW).

11. Adopt Resolution No. 25-184 Accepting Quotes and Awarding Contract for Maintenance Project #25-60, Pumphouse No. 1 Roof Replacement

12. Adopt Resolution #25-185 Supporting State Highway 47/St. Francis Boulevard Improvements

6. **Public Hearing**

7. **Council Business**
 1. Adopt Resolution #25-176 Accepting Bids and Awarding Contract for 2025 Pavement Skim Patching Project, Maintenance Project #25-56

8. **Mayor/Council/Staff Input**

9. **Adjournment**

CC Regular Session

Meeting Date: 08/12/2025

Primary Strategic Plan Initiative:

Title:

Receive June 2025 Finance Reports - General Fund, EDA, and Enterprise Funds

Purpose/Background:

Purpose: Receive June 2025 Financial Reports - General, EDA, Water, Sewer, Street Lighting, Recycling and Storm Drainage.

Brief summary of actual revenues and expenditures-to-date in comparison to adopted budget for the respective funds.

Recommendation:

No action required. Informational only.

Outcome/Action:

No action required. Informational only.

Attachments

- June 2025 General Fund Financial Report-Budget to Actual
- June 2025 EDA Fund Financial Report - Budget to Actual
- June 2025 Enterprise Funds Financial Reports - Budget to Actual
- June 2025 Summary of Adopted Budgets/Expenditures to Date

Form Review

Inbox	Reviewed By	Date
Brian Hagen	Brian Hagen	08/07/2025 03:49 PM
Form Started By: Diana Lund		Started On: 07/30/2025 07:23 AM
Final Approval Date: 08/07/2025		

**CITY OF RAMSEY
FINANCIAL STATEMENT**



JANUARY 1, 2025 THROUGH PERIOD ENDING: June 30, 2025

**GENERAL FUND EXPENDITURES
- BY DEPARTMENT -**

Dept	2025 BUDGET	2025 YTD GENERAL LEDGER
Admin (inclcd elections, legal & newsletter)	1,392,483.00	700,248.30
Building Inspections	888,040.00	383,156.69
Council/Commissions (inclcd charter, council contingen	245,486.00	66,796.33
Data Processing	1,097,132.00	567,275.05
Engineering	644,812.00	554,806.57
Finance (inclcd assessing)	666,692.00	534,652.53
Fire (inclcd Civil Defense)	2,096,484.00	1,214,331.06
Gen Govt Buildings	804,616.00	318,090.99
Parks	2,224,661.00	1,053,456.24
Planning & Zoning	1,149,903.00	556,010.94
Police (inclcd animal control & comm orient)	6,356,700.00	3,016,966.91
Streets (inclcd traffic eng & snow/ice)	2,806,601.00	1,109,074.70
Grand Total	20,373,610.00	10,074,866.31

**GENERAL FUND EXPENDITURES
- BY CATEGORY -**

Category	2025 BUDGET	2025 YTD GENERAL LEDGER
Capital Outlay	577,000.00	530,526.13
Other Services & Charges	3,602,860.00	1,555,103.04
Personal Services	14,484,111.00	7,384,492.63
Supplies	1,603,266.00	604,744.51
Transfers out	106,373.00	-
Grand Total	20,373,610.00	10,074,866.31

**GENERAL FUND REVENUES
- BY CATEGORY -**

Category	2025 BUDGET	2025 YTD GENERAL LEDGER
Taxes	16,874,046.00	-
Charges for Services	780,700.00	583,058.03
Business Licenses/Permits	86,350.00	74,543.23
Fines and Forfeits	48,000.00	26,861.52
Federal Intergovernmental	500.00	-
State Intergovernmental	755,500.00	132,157.75
Interest	50,000.00	-
Miscellaneous	20,600.00	12,545.28
Non-Business Licenses/Permits	874,520.00	653,635.56
Transfers in	883,394.00	-
Grand Total	20,373,610.00	1,482,801.37

This report reflects year to date revenue and expenditures as compared to annual budget.
It does not reflect fund balance.

PREPARED BY: FINANCE DEPARTMENT

CITY OF RAMSEY FINANCIAL STATEMENT

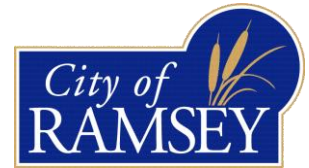

JANUARY 1, 2025 THROUGH PERIOD ENDING: June 30, 2025

GENERAL FUND EXPENDITURES - BY DEPARTMENT

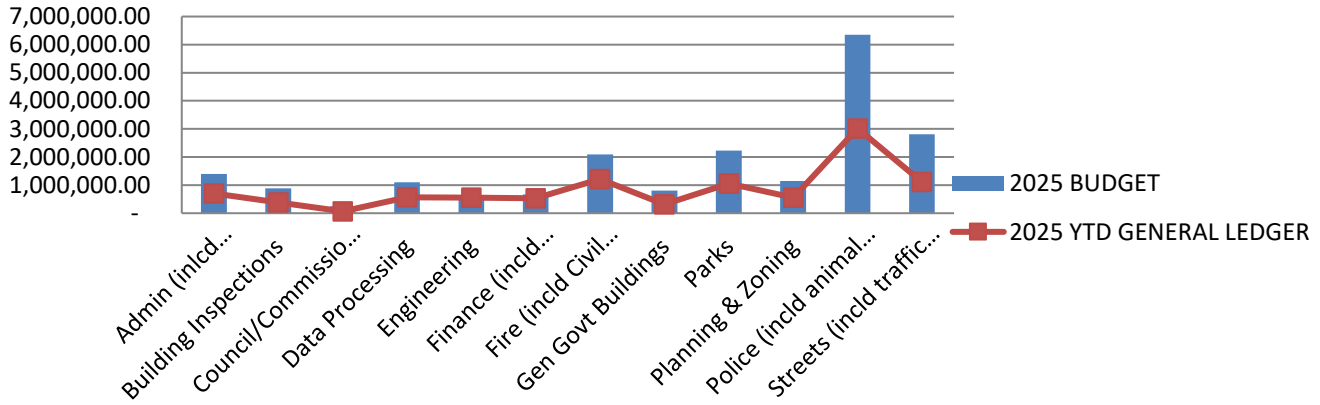

GENERAL FUND EXPENDITURES - BY CATEGORY

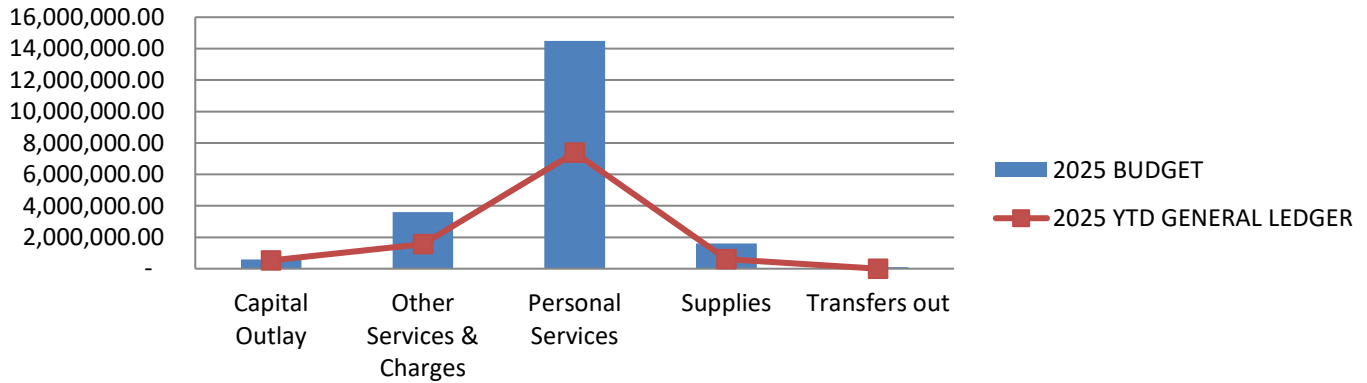

GENERAL FUND REVENUES

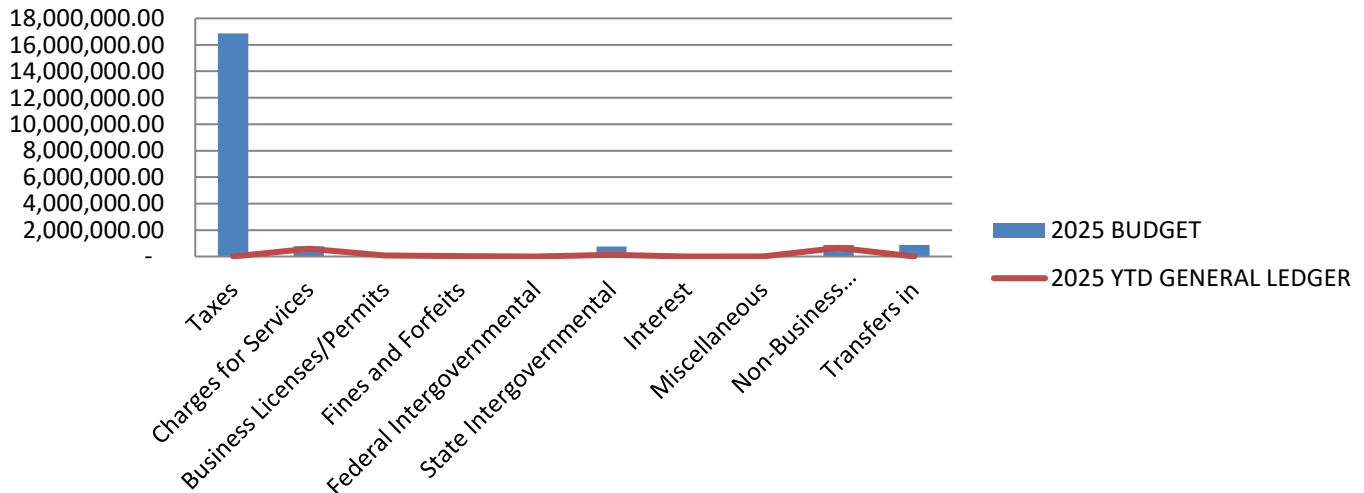

This report reflects year to date revenue and expenditures as compared to annual budget. It does not reflect fund balance.

PREPARED BY: FINANCE DEPARTMENT

**CITY OF RAMSEY
FINANCIAL STATEMENT**

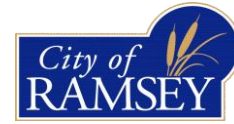

JANUARY 1, 2025 THROUGH PERIOD ENDING: June 30, 2025

REVENUES				
BUSINESS UNIT	9230	EDA		
GENERAL LEDGER ACCOUNT	CURRENT YEAR REQUESTED BUDGET	CURRENT YTD GENERAL LEDGER	-% of Budget-	
4011 CURRENT-AD VALOREM TAXES	86,367.00	-	0.00%	
4609 OTHER MISCELLANEOUS REVENUES	-	79,923.50	0.00%	
4701 INTEREST ON INVESTMENTS	5,000.00	-	0.00%	
Grand Total	91,367.00	79,923.50		

EXPENDITURES				
BUSINESS UNIT	9230	EDA		
GENERAL LEDGER ACCOUNT	CURRENT YEAR REQUESTED BUDGET	CURRENT YTD GENERAL LEDGER	-% of Budget-	
6105 TEMPORARY-WAGES & SALARIES	1,000.00	100.00	10.00%	
6122 FICA/MEDICARE CONTRIBUTIONS	80.00	7.65	9.56%	
6133 WORKERS COMP INSURANCE PREMIUM	-	2.01	0.00%	
6249 MISCELLANEOUS OPERATING SUPPLY	19,000.00	(1,624.32)	-8.55%	
6315 MISCELLANEOUS PROFESSIONAL SER	36,200.00	2,666.67	7.37%	
6331 TRAVEL & LODGING	2,500.00	707.16	28.29%	
6335 TRAINING	5,100.00	2,235.00	43.82%	
6361 GENERAL LIABILITY/PROPERTY INS	287.00	221.22	77.08%	
6451 MEMBERSHIP DUES	2,200.00	2,530.48	115.02%	
6246 MARKETING & PROMOTIONS	25,000.00	12,955.13	51.82%	
Grand Total	91,367.00	19,801.00		

Note: The Finance Department has highlighted line items that may be trending towards exceeding budget OR not may not have been included in the adopted budget.

**CITY OF RAMSEY
FINANCIAL STATEMENT**



JANUARY 1, 2025 THROUGH PERIOD ENDING: June 30, 2025

REVENUES				
BUSINESS UNIT	9601	WATER UTILITY		
GENERAL LEDGER ACCOUNT	2025 BUDGET	2025 YTD GENERAL LEDGER	-% of Budget-	
4140 CREDIT CARD PROCESSING FEES	(32,000.00)	(13,482.53)	42.13%	
4273 OTHER STATE GRANTS & AIDS	-	(271.83)	0.00%	
4609 OTHER MISCELLANEOUS REVENUES	10,000.00	6,060.11	60.60%	
4651 WATER REVENUE	-	289.93	0.00%	
4652 WATER SALES - RESIDENTIAL	2,128,123.00	378,260.41	17.77%	
4653 WATER SALES-COMMERCIAL	1,187,930.00	97,915.59	8.24%	
4654 WATER PENALTIES	50,618.00	17,040.56	33.67%	
4655 WATER METER INSTALLATION	30,000.00	18,900.00	63.00%	
4656 WATER METERS	60,000.00	45,106.95	75.18%	
4657 CONNECTION/RECONNECTION FEES	150.00	150.00	100.00%	
4701 INTEREST ON INVESTMENTS	40,000.00	-	0.00%	
4606 DEVELOPER FEES (WAC)	362,427.00	490,918.50	135.45%	
4601 MISCELLANEOUS REVENUE	-	711.47	0.00%	
Grand Total	3,837,248.00	1,041,599.16		

EXPENSES				
BUSINESS UNIT	9601	WATER UTILITY		
GENERAL LEDGER ACCOUNT	2025 BUDGET	2025 YTD GENERAL LEDGER	-% of Budget-	
6102 F.T. REGULAR-WAGES & SALARIES	421,920.00	130,126.49	30.84%	
6103 FULL TIME-REGULAR-OVERTIME	25,000.00	10,387.40	41.55%	
6105 TEMPORARY-WAGES & SALARIES	29,221.00	4,805.81	16.45%	
6121 PERA CONTRIBUTIONS	62,862.00	11,506.71	18.30%	
6122 FICA/MEDICARE CONTRIBUTIONS	35,142.00	12,511.79	35.60%	
6131 GROUP INSURANCE	56,245.00	24,573.38	43.69%	
6133 WORKERS COMP INSURANCE PREMIUM	26,140.00	13,291.40	50.85%	
6208 MISCELLANEOUS OFFICE SUPPLIES	750.00	-	0.00%	
6223 GASOLINE	9,500.00	3,793.04	39.93%	
6225 DIESEL FUEL	500.00	-	0.00%	
6229 SHOP MATERIALS	1,200.00	842.41	70.20%	
6231 UNIFORMS & TURN-OUT GEAR	5,000.00	4,159.15	83.18%	
6239 FIRST AID SUPPLIES	100.00	-	0.00%	
6249 MISCELLANEOUS OPERATING SUPPLY	15,500.00	4,364.35	28.16%	
6257 OTHER VEHICLE PARTS	12,000.00	4,456.12	37.13%	
6273 UTILITY SYSTEM MAINT SUPPLIES	675,000.00	66,306.39	9.82%	
6281 SMALL TOOLS & MINOR EQUIPMENT	12,000.00	4,240.83	35.34%	
6292 WATER METERS FOR RESALE	125,000.00	139,269.38	111.42%	
6315 MISCELLANEOUS PROFESSIONAL SER	58,000.00	800.00	1.38%	
6322 POSTAGE	2,000.00	202.32	10.12%	
6334 MILEAGE REIMBURSEMENT	800.00	-	0.00%	
6335 TRAINING	6,000.00	3,135.35	52.26%	
6352 GENERAL NOTICE & PUBLIC INFOR	350.00	-	0.00%	
6361 GENERAL LIABILITY/PROPERTY INS	45,192.00	44,104.87	97.59%	
6371 ELECTRIC UTILITIES	200,000.00	48,839.09	24.42%	
6372 WATER/IRRIGATION	2,500.00	262.27	10.49%	
6373 GAS	9,000.00	3,817.50	42.42%	
6374 REFUSE/RECYCLING	1,800.00	617.63	34.31%	
6381 BUILDING & STRUCTURE REPAIR	17,035.00	5,293.67	31.08%	
6405 OFFICE & DATA PROCESSING EQUIP	8,500.00	-	0.00%	
6439 OTHER MISCELLANEOUS	67,000.00	4,946.03	7.38%	
6451 MEMBERSHIP DUES	1,000.00	425.00	42.50%	
6489 OTHER CONTRACTED SERVICES	84,000.00	17,140.90	20.41%	
6722 DEPRECIATION	1,758,000.00	-	0.00%	
6820 OPERATING TRANSFERS TO OTHER F	59,000.00	-	0.00%	
6436 WATER EFFICIENCY REBATE PROG	-	3,029.16	0.00%	
Grand Total	3,833,257.00	567,248.44		

**CITY OF RAMSEY
FINANCIAL STATEMENT**

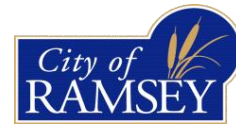

JANUARY 1, 2025 THROUGH PERIOD ENDING: June 30, 2025

REVENUES				
BUSINESS UNIT	9602	SEWER UTILITY		
GENERAL LEDGER ACCOUNT	2025 BUDGET	2025 YTD GENERAL LEDGER	-% of Budget-	
4140 CREDIT CARD PROCESSING FEES	(35,000.00)	(14,716.47)	42.05%	
4356 SEWER AVAILABILITY CHARGE-ADM	7,000.00	2,733.50	39.05%	
4661 RESIDENTIAL-SEWER CHARGES	1,912,050.00	502,166.44	26.26%	
4662 COMMERCIAL-SEWER CHARGES	484,000.00	121,039.81	25.01%	
4663 SEWER PENALTIES	40,000.00	23,273.85	58.18%	
4701 INTEREST ON INVESTMENTS	38,600.00	-	0.00%	
4606 DEVELOPER FEES (WAC)	138,900.00	67,212.00	48.39%	
4601 MISCELLANEOUS REVENUE		1,862.19	0.00%	
Grand Total	2,585,550.00	703,571.32		

EXPENSES				
BUSINESS UNIT	9602	SEWER UTILITY		
GENERAL LEDGER ACCOUNT	2025 BUDGET	2025 YTD GENERAL LEDGER	-% of Budget-	
6102 F.T. REGULAR-WAGES & SALARIES	284,147.00	78,539.99	27.64%	
6103 FULL TIME-REGULAR-OVERTIME	1,000.00	975.02	97.50%	
6105 TEMPORARY-WAGES & SALARIES	-	2,125.08	0.00%	
6121 PERA CONTRIBUTIONS	40,545.00	6,372.53	15.72%	
6122 FICA/MEDICARE CONTRIBUTIONS	22,258.00	6,865.57	30.85%	
6131 GROUP INSURANCE	34,150.00	-	0.00%	
6133 WORKERS COMP INSURANCE PREMIUM	13,962.00	8,018.25	57.43%	
6223 GASOLINE	4,300.00	429.77	9.99%	
6225 DIESEL FUEL	3,500.00	1,185.24	33.86%	
6229 SHOP MATERIALS	500.00	71.40	14.28%	
6249 MISCELLANEOUS OPERATING SUPPLY	15,000.00	4,882.04	32.55%	
6257 OTHER VEHICLE PARTS	8,000.00	324.86	4.06%	
6273 UTILITY SYSTEM MAINT SUPPLIES	5,000.00	-	0.00%	
6275 OTHER EQUIPMENT PARTS	8,000.00	-	0.00%	
6281 SMALL TOOLS & MINOR EQUIPMENT	5,000.00	367.67	7.35%	
6315 MISCELLANEOUS PROFESSIONAL SER	2,000.00	800.00	40.00%	
6323 CELLULAR PHONES	2,000.00	1,305.44	65.27%	
6334 MILEAGE REIMBURSEMENT	400.00	123.90	30.98%	
6335 TRAINING	8,000.00	90.00	1.13%	
6361 GENERAL LIABILITY/PROPERTY INS	30,000.00	21,956.17	73.19%	
6371 ELECTRIC UTILITIES	30,000.00	10,814.15	36.05%	
6372 WATER/IRRIGATION	2,000.00	262.27	13.11%	
6373 GAS	7,500.00	3,450.76	46.01%	
6374 REFUSE/RECYCLING	1,500.00	617.63	41.18%	
6377 SEWER SERVICE CHARGE	1,277,649.00	745,295.53	58.33%	
6381 BUILDING & STRUCTURE REPAIR	10,835.00	2,958.66	27.31%	
6489 OTHER CONTRACTED SERVICES	45,000.00	11,821.52	26.27%	
6722 DEPRECIATION	793,692.00	-	0.00%	
6820 OPERATING TRANSFERS TO OTHER F	53,000.00	-	0.00%	
Grand Total	2,708,938.00	909,653.45		

**CITY OF RAMSEY
FINANCIAL STATEMENT**

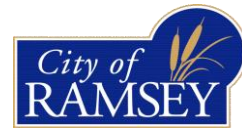

JANUARY 1, 2025 THROUGH PERIOD ENDING: June 30, 2025

REVENUES				
BUSINESS UNIT	9603	STREET LIGHT UTILITY		
GENERAL LEDGER ACCOUNT	2025 BUDGET	2025 YTD GENERAL LEDGER	-% of Budget-	
4140 CREDIT CARD PROCESSING FEES	(6,000.00)	(2,200.96)	36.68%	
4681 CHARGES FOR STREET LIGHTS	179,000.00	48,130.54	26.89%	
4683 STREET LIGHTING PENALTIES	4,994.00	2,772.20	55.51%	
4701 INTEREST ON INVESTMENTS	2,000.00	-	0.00%	
4684 PRIORITY STREET LIGHT	58,000.00	15,263.34	26.32%	
Grand Total	237,994.00	63,965.12		

EXPENSES				
BUSINESS UNIT	9603	STREET LIGHT UTILITY		
GENERAL LEDGER ACCOUNT	2025 BUDGET	2025 YTD GENERAL LEDGER	-% of Budget-	
6371 ELECTRIC UTILITIES	140,000.00	53,812.06	38.44%	
6489 OTHER CONTRACTED SERVICES	20,000.00	7,651.69	38.26%	
6722 DEPRECIATION	40,000.00	-	0.00%	
6820 OPERATING TRANSFERS TO OTHER F	31,000.00	-	0.00%	
Grand Total	231,000.00	61,463.75		

Note: The Finance Department has highlighted line items that may be trending towards exceeding budget OR not may not have been included in the adopted budget.

**CITY OF RAMSEY
FINANCIAL STATEMENT**

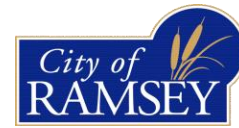

JANUARY 1, 2025 THROUGH PERIOD ENDING: June 30, 2025

REVENUES				
BUSINESS UNIT	9604	RECYCLING UTILITY		
GENERAL LEDGER ACCOUNT	2025 BUDGET	2025 YTD GENERAL LEDGER	-% of Budget-	
4140 CREDIT CARD PROCESSING FEES	(9,000.00)	(3,416.83)	37.96%	
4287 OTHER LOCAL GOVERNMENT GRANTS	75,000.00	-	0.00%	
4609 OTHER MISCELLANEOUS REVENUES	1,200.00	1,031.80	85.98%	
4671 RECYCLING CHARGES	468,000.00	117,888.83	25.19%	
4672 RECYCLING PENALTIES	9,400.00	5,109.52	54.36%	
4701 INTEREST ON INVESTMENTS	4,000.00	-	0.00%	
Grand Total	548,600.00	120,613.32		

EXPENSES				
BUSINESS UNIT	9604	RECYCLING UTILITY		
GENERAL LEDGER ACCOUNT	2025 BUDGET	2025 YTD GENERAL LEDGER	-% of Budget-	
6102 F.T. REGULAR-WAGES & SALARIES	32,375.00	13,923.12	43.01%	
6103 FULL TIME-REGULAR-OVERTIME	1,000.00	742.49	74.25%	
6104 PART TIME-WAGES & SALARIES	200.00	124.65	62.33%	
6105 TEMPORARY-WAGES & SALARIES		377.18	0.00%	
6121 PERA CONTRIBUTIONS	2,182.00	1,162.70	53.29%	
6122 FICA/MEDICARE CONTRIBUTIONS	2,487.00	1,196.88	48.13%	
6131 GROUP INSURANCE	3,029.00	-	0.00%	
6133 WORKERS COMP INSURANCE PREMIUM	236.00	75.96	32.19%	
6249 MISCELLANEOUS OPERATING SUPPLY	32,000.00	17,204.51	53.76%	
6322 POSTAGE	100.00	-	0.00%	
6489 OTHER CONTRACTED SERVICES	483,000.00	242,148.13	50.13%	
Grand Total	556,609.00	276,955.62		

Note: The Finance Department has highlighted line items that may be trending towards exceeding budget OR not may not have been included in the adopted budget.

**CITY OF RAMSEY
FINANCIAL STATEMENT**



JANUARY 1, 2025 THROUGH PERIOD ENDING: June 30, 2025

REVENUES				
BUSINESS UNIT	9605	STORM WATER UTILITY		
GENERAL LEDGER ACCOUNT	2025 BUDGET	2025 YTD GENERAL LEDGER	-% of Budget-	
4140 CREDIT CARD PROCESSING FEES	(16,000.00)	(7,025.22)	43.91%	
4693 STORM WATER-RESIDENTIAL	732,900.00	191,284.06	26.10%	
4694 STORM WATER-COMMERCIAL	786,600.00	200,880.46	25.54%	
4695 STORM WATER-PENALTIES	26,250.00	12,419.45	47.31%	
4701 INTEREST ON INVESTMENTS	3,000.00	-	0.00%	
4722 SALE OF GENERAL FIXED ASSETS		43,000.00	0.00%	
Grand Total	1,532,750.00	440,558.75		

EXPENSES				
BUSINESS UNIT	9605	STORM WATER UTILITY		
GENERAL LEDGER ACCOUNT	2025 BUDGET	2025 YTD GENERAL LEDGER	-% of Budget-	
6102 F.T. REGULAR-WAGES & SALARIES	281,114.00	50,443.64	17.94%	
6105 TEMPORARY-WAGES & SALARIES	-	256.00	0.00%	
6121 PERA CONTRIBUTIONS	40,831.00	3,806.28	9.32%	
6122 FICA/MEDICARE CONTRIBUTIONS	21,538.00	4,024.12	18.68%	
6131 GROUP INSURANCE	39,421.00	591.87	1.50%	
6133 WORKERS COMP INSURANCE PREMIUM	14,733.00	8,050.12	54.64%	
6225 DIESEL FUEL	10,500.00	4,151.06	39.53%	
6231 UNIFORMS & TURN-OUT GEAR		393.75	0.00%	
6249 MISCELLANEOUS OPERATING SUPPLY	11,000.00	7,211.74	65.56%	
6257 OTHER VEHICLE PARTS	12,500.00	6,669.86	53.36%	
6315 MISCELLANEOUS PROFESSIONAL SER	35,000.00	1,581.00	4.52%	
6361 GENERAL LIABILITY/PROPERTY INS	12,500.00	6,454.35	51.63%	
6371 ELECTRIC UTILITIES	12,000.00	4,783.06	39.86%	
6372 WATER/IRRIGATION	3,500.00	262.27	7.49%	
6373 GAS	7,200.00	3,450.74	47.93%	
6374 REFUSE/RECYCLING	1,500.00	481.34	32.09%	
6451 MEMBERSHIP DUES	65,000.00	1,440.00	2.22%	
6489 OTHER CONTRACTED SERVICES	55,000.00	11,516.19	20.94%	
6722 DEPRECIATION	549,096.00	-	0.00%	
6820 OPERATING TRANSFERS TO OTHER F	49,000.00	-	0.00%	
Grand Total	1,221,433.00	115,567.39		

Note: The Finance Department has highlighted line items that may be trending towards exceeding budget OR not may not have been included in the adopted budget.

**CITY OF RAMSEY
YEAR-TO-DATE BY BUSINESS UNIT**

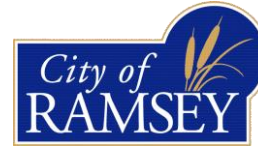

JANUARY 1, 2025 THROUGH PERIOD ENDING:

June 30, 2025

GENERAL FUND EXPENDITURES BY DEPARTMENT	2025 ADOPTED BUDGET	CURRENT YTD POSTED EXP	6/12 ADOPTED BUDGET (Jun)	% of Budget Used (50.0% is 6/12)	BUDGET AMOUNT REMAINING
Admin (inclcd elections, legal & newsletter)	1,392,483.00	700,248.30	696,241.50	50.29%	692,234.70
Building Inspections	886,040.00	383,156.69	443,020.00	43.24%	502,883.31
Council/Commissions (inclcd charter, council contingency)	245,486.00	66,796.33	122,743.00	27.21%	178,689.67
Data Processing	1,097,132.00	567,275.05	548,566.00	51.71%	529,856.95
Engineering (personnel costs allocated after year-end)	644,812.00	554,806.57	322,406.00	86.04%	90,005.43
Finance (inclcd assessing) (personnel costs allocated after year-end)	666,692.00	534,652.53	333,346.00	80.19%	132,039.47
Fire (inclcd Civil Defense)	2,096,484.00	1,214,331.06	1,048,242.00	57.92%	882,152.94
Gen Govt Buildings	804,616.00	318,090.99	402,308.00	39.53%	486,525.01
Parks	2,224,661.00	1,053,456.24	1,112,330.50	47.35%	1,171,204.76
Planning & Zoning	1,149,903.00	556,010.94	574,951.50	48.35%	593,892.06
Police (inclcd animal control & comm orient)	6,356,700.00	3,016,966.91	3,178,350.00	47.46%	3,339,733.09
Streets (inclcd traffic eng & snow/ice)	2,806,601.00	1,109,074.70	1,403,300.50	39.52%	1,697,526.30
TOTAL	20,371,610.00	10,074,866.31	10,185,805.00	49.46%	10,296,743.69

ENTERPRISE EXPENDITURES BY FUND	2025 ADOPTED BUDGET	CURRENT YTD POSTED EXP	6/12 ADOPTED BUDGET (Jun)	% of Budget Used (50.0% is 6/12)	BUDGET AMOUNT REMAINING	*BUDGETED DEPRECIATION (part of "2025 BUDGET")
Water (budgeted depreciation not booked until after year-end)	3,833,257.00	567,248.44	1,916,628.50	14.80%	3,266,008.56	\$ 1,758,000.00
Sewer (budgeted depreciation not booked until after year-end)	2,708,938.00	909,653.45	1,354,469.00	33.58%	1,799,284.55	\$ 793,692.00
Street Light (budgeted depreciation not booked until after year-end)	231,000.00	61,463.75	115,500.00	26.61%	169,536.25	\$ 40,000.00
Recycling	556,609.00	276,955.62	278,304.50	49.76%	279,653.38	N/A
Storm Water (budgeted depreciation not booked until after year-end)	1,221,433.00	115,567.39	610,716.50	9.46%	1,105,865.61	\$ 549,096.00
TOTAL	8,551,237.00	1,930,888.65	4,275,618.50	22.58%	6,620,348.35	\$ 3,140,788.00

EDA FUND EXPENDITURES	2025 ADOPTED BUDGET	CURRENT YTD POSTED EXP	6/12 ADOPTED BUDGET (Jun)	% of Budget Used (50.0% is 6/12)	BUDGET AMOUNT REMAINING
Economic Development	91,367.00	19,801.00	45,683.50	21.67%	71,566.00

CC Regular Session

Meeting Date: 08/12/2025

Primary Strategic Plan Initiative:

Title:

Receive Cash and Investments for Period Ending July 31, 2025

Purpose/Background:

Purpose: Receive reports of the city's cash and investments for the period ending July 31, 2025.

Cash and investment report shows the monthly cash flow - receipts and expenditures through July 31, 2025 with the current listing of the city's investment portfolio.

Recommendation:

No action required. Informational only.

Outcome/Action:

No action required. Informational only.

Attachments

Cash & Investments for Period Ending July 31, 2025

Form Review

Inbox

Brian Hagen

Form Started By: Diana Lund

Final Approval Date: 08/07/2025

Reviewed By

Brian Hagen

Date

08/07/2025 03:49 PM

Started On: 07/30/2025 07:32 AM

CITY OF RAMSEY
REPORT OF POOLED CASH FLOWS
Period Ended July 31, 2025

	July-25	2025
	CURRENT MONTH	YEAR-TO-DATE
CASH AND TEMPORARY INVESTMENTS		
BEGINNING BALANCE (Includes 2022 Bond Proceeds)	\$ 80,697,560.07	\$ 88,846,329.91
CASH INFLOWS:		
Daily Deposit	2,229,345.24	7,567,303.10
Tax Settlements	5,125,846.16	12,582,251.53
U/B Receipts	19,019.28	1,014,309.27
Credit Cards (Includes Utility Billing)	366,846.57	4,173,402.76
Interest Earnings [Net of Interest Paid on Investments]	530,158.31	1,397,713.36
Bond Proceeds-int	-	3,610.76
	8,271,215.56	26,738,590.78
TOTAL CASH INFLOW	\$ 8,271,215.56	\$ 26,738,590.78
TOTAL CASH AVAILABLE	\$ 88,968,775.63	\$ 115,584,920.69
CASH OUTFLOWS:		
Prepaid Checks	1,176,490.43	7,307,369.27
Bills Lists	862,318.78	8,819,200.45
Pay Estimates	2,447,744.58	10,510,704.64
Credit Cards	10,033.32	94,111.79
Payroll - Net	598,944.63	4,347,160.31
Flex Reimbursement	-	315.04
Void Checks/Dormant Checks Paid	(10,186.32)	(18,440.65)
Debt Service	-	639,325.63
Miscellaneous [Bank Charges; etc.]	292.50	2,036.50
	5,085,637.92	31,701,782.98
TOTAL CASH OUTFLOW	\$ 5,085,637.92	\$ 31,701,782.98
POOLED CASH AND TEMPORARY INVESTMENTS		
ENDING BALANCE	\$ 83,883,137.71	\$ 83,883,137.71
MEMO - NET 2025 CASH INFLOW (OUTFLOW)	3,185,577.64	(4,963,192.20)
INVESTMENT PORTFOLIO SUMMARY		
BEGINNING BALANCE - BV	\$ 77,002,045.73	72,720,097.99
Purchases	7,565,046.21	20,673,848.78
Maturities/Sales	(12,300,000.00)	(21,126,854.83)
	72,267,091.94	72,267,091.94
ENDING BALANCE	\$ 72,267,091.94	\$ 72,267,091.94

2025 CASH AND INVESTMENT ACTIVITY

CITY	STATED					PRIN		SOLD/	BV
INVEST #	MAT	BROKER	SECURITY	FDIC #	CUSIP	BAL	PURCH	MATURE	PRIN
	DATE		DESCRIP			1/1/2025	2025	2025	BAL
									12/31/2025
240731B	7/31/2025	4M	4M TERM SERIES			4,000,000.00		4,000,000.00	0.00
250731B	1/29/2026	4M	4M TERM SERIES				4,000,000.00	0.00	4,000,000.00
250626A	1/26/2026	4M	4M TERM SERIES				6,000,000.00	0.00	6,000,000.00
250626B	6/24/2026	4M	4M TERM SERIES				4,000,000.00	0.00	4,000,000.00
241213A	12/12/2025	4M	4M TERM SERIES			4,000,000.00		0.00	4,000,000.00
241213B	7/11/2025	4M	4M TERM SERIES			8,000,000.00		8,000,000.00	0.00
									18,000,000.00
201230	5/1/2025	Northland	FREEMONT NY TAX		356731-CA-5	300,000.00		300,000.00	0.00
250221	2/22/2027	Northland	CD-NEIGHBOR FCU		64017aABP8		245,000.00	0.00	245,000.00
250304A	6/1/2026	Northland	DUBUQUE IA TAX		263868-LW-9		190,000.00	0.00	190,000.00
250304B	6/1/2027	Northland	DUBUQUE IA TAX		263868-LX-7		295,000.00	0.00	295,000.00
190227	12/1/2025	Northland	COOK COUNTY SCHOOL DISTRICT		032879-TC-2	500,000.00		0.00	500,000.00
210625	7/15/2026	Northland	EAST LYME CONN TAX		273587-P3-3	200,000.00		0.00	200,000.00
191003A	12/1/2026	Northland	SCOTT BLUFF CTY SCHOOL DIST		810164-CQ-4	385,000.00		0.00	385,000.00
200113	3/1/2027	Northland	RICHLAND SCHOOL DISTRICT		764080-FT-9	165,000.00		0.00	165,000.00
200825A	8/1/2027	Northland	CENTINELA VALLEY CA HS		15239-RP-4	250,000.00		0.00	250,000.00
210401	12/1/2027	Northland	RUSH COUNTY KANSAS TAX		781834-D4-9	180,000.00		0.00	180,000.00
120308C	12/1/2027	Northland	SHOREWOOD WIS TAX		825230-LB-9	225,000.00		0.00	225,000.00
190402	2/1/2028	Northland	CLOQUET MN TAX		189036-PS-9	150,000.00		0.00	150,000.00
191016B	4/1/2028	Northland	COLUMBUS OH TAX		199492E339	285,000.00		0.00	285,000.00
211020A	7/15/2028	Northland	MOUNT HILLS TOWNSHIP SCHOOL		6215S3-E6-7	430,000.00		0.00	430,000.00
200914	8/1/2028	Northland	BURLESON TX IDS ZERO CPN		121403-AE6	500,000.00		0.00	500,000.00
120308D	12/1/2028	Northland	SHOREWOOD WIS TAX		825230-LC-7	465,000.00		0.00	465,000.00
200625	3/1/2029	Northland	LAWRENCE MASS TAX		520228-6Q-5	180,000.00		0.00	180,000.00
200923	7/15/2029	Northland	WILKINSBURGO BORO PA TAX		968529-JV-0	265,000.00		0.00	265,000.00
200825B	8/1/2029	Northland	CENTINELA VALLEY CA HS		15239-RR-0	270,000.00		0.00	270,000.00
210615	8/1/2030	Northland	MN STATE TAX		60412A-VP-5	500,000.00		0.00	500,000.00
									5,680,000.00
220419	3/1/2025	UBS	MARYLAND STATE COMM DEV TAX		57419RC78	750,000.00		750,000.00	0.00
250212A	2/12/2027	UBS	CD-MORGAN STANI	32992	61690DP44		245,000.00	0.00	245,000.00
250212B	2/12/2027	UBS	CD-MORGAN STANI	34221	61776NLH4		245,000.00	0.00	245,000.00
250218	2/18/2027	UBS	CD-MERRICK BANK	34519	59013K4M5		245,000.00	0.00	245,000.00
230317	3/17/2025	UBS	CD-MANUFACTURE	588	5647595C3	243,000.00		243,000.00	0.00
230322	3/24/2025	UBS	CD-PINNACLE BANF	35583	72345SLG4	248,000.00		248,000.00	0.00
161114A	7/1/2025	UBS	LEXINGTON FAYETTE AIRPORT		52909MCA0	300,000.00		300,000.00	0.00
211223	8/1/2025	UBS	HAWAII STATE		41972YQ3	500,000.00		0.00	500,000.00
191101	8/1/2025	UBS	MASSACHUSETTS ST WATER		576051VFO	400,000.00		0.00	400,000.00
201119E	12/1/2025	UBS	WARREN HEIGHTS OH BUILDING		936121JX1	175,000.00		0.00	175,000.00
191122A	12/1/2025	UBS	WARRENSVILLE HEIGHTS OHIO		936121JM5	250,000.00		0.00	250,000.00
191105	3/1/2026	UBS	MARYLAND STATE COMM DEV		57419TDZ1	320,000.00		0.00	320,000.00
220519	3/15/2026	UBS	NEW YORK DEV		6500355P6	105,000.00		0.00	105,000.00
220316	3/16/2026	UBS	CD-GOLDMAN SACHS			245,000.00		0.00	245,000.00
201105	4/1/2026	UBS	PARAMUS NJ SCHOOL		699347LF5	500,000.00		0.00	500,000.00
200113	4/15/2026	UBS	PHILADELPHIA AUTHORITY-ZERO COUP		71781LBU2	300,000.00		0.00	300,000.00
201204	4/15/2026	UBS	LONG BEACH CITY SCHOOL DIS		542535LY3	750,000.00		0.00	750,000.00
210309	6/1/2026	UBS	BEVERLY HILLS CA PUB		088006KA8	300,000.00		0.00	300,000.00
191115A	7/1/2026	UBS	LEXINGTON FAYETEE URBAN COUNTY		52909MDR2	470,000.00		0.00	470,000.00
210630	7/15/2026	UBS	MICHIGAN CITY IND SCHOOL		594381HJ7	500,000.00		0.00	500,000.00
200326B	8/1/2026	UBS	SAN BERNARDINO COMM		79672ONA47	500,000.00		0.00	500,000.00
210514	10/1/2026	UBS	BOSSIER CITY LA UTIL		100216FZ8	500,000.00		0.00	500,000.00
201221	10/1/2026	UBS	LANCASTER OH SCHOOL DIST		514264FGO	1,675,000.00		0.00	1,675,000.00
210621	11/1/2026	UBS	REGIONAL TRANSPORTATION		759136VD3	500,000.00		0.00	500,000.00
191219B	11/1/2026	UBS	OPELIKA ALABAMA TAX		683489ZE1	400,000.00		0.00	400,000.00
191016A	12/1/2026	UBS	DENVER CITY & COUNTY HSG		24917NAG6	500,000.00		0.00	500,000.00
210311	1/1/2027	UBS	FORT LAUDERDALE FLA SPL		347622CW0	500,000.00		0.00	500,000.00
210408B	1/15/2027	UBS	APACHE COUNTY ARIZ		03743TAF9	590,000.00		0.00	590,000.00
200925	4/1/2027	UBS	WESTERN WASHINGTON UNIV		959878RJO	500,000.00		0.00	500,000.00
211206	5/1/2027	UBS	PIMA COUNTY AZ		72178JAF0	500,000.00		0.00	500,000.00
210308B	6/1/2027	UBS	RIO RANCHO NEW MEXICO TAX		767169EP6	580,000.00		0.00	580,000.00
191219A	6/1/2027	UBS	UNIVERSITY OF NORTHERN COLORADO		914733DY3	360,000.00		0.00	360,000.00
210302	8/1/2027	UBS	VISTA CA UNI SCHOOL		928346P45	1,050,000.00		0.00	1,050,000.00
210219	9/1/2027	UBS	VIRGINIA COLLEGE BLDG			500,000.00		0.00	500,000.00
210121	10/1/2027	UBS	MIAMI DADE COUNTY TAX		59333NV91	750,000.00		0.00	750,000.00
191022	10/1/2027	UBS	NEW YORK NY TAX		64966QEK2	500,000.00		0.00	500,000.00
160802	12/1/2027	UBS	TOOLE CITY UT TAX		89033RBU7	400,000.00		0.00	400,000.00
190725A	12/1/2027	UBS	WRIGHT COUNTY TAXABLE		982276BK2	630,000.00		0.00	630,000.00
210713	2/1/2028	UBS	TEXAS PUB FIN AUTHORITY		882669BW3	325,000.00		0.00	325,000.00
210430	6/1/2028	UBS	BEVERLY HILLS CA PUB		088006KC4	500,000.00		0.00	500,000.00
220207A	7/1/2028	UBS	PHOENIX AZ CIVIC		71883RRS4	165,000.00		0.00	165,000.00
210617A	7/1/2028	UBS	EL SEGUNDO CA PENSION		284035AG7	1,000,000.00		0.00	1,000,000.00
210408A	7/1/2028	UBS	PHOENIX AZ CIVIC		71884AFH4	500,000.00		0.00	500,000.00
210930	8/1/2028	UBS	CHARTER OAKS CA		161285SD4	250,000.00		0.00	250,000.00

2025 CASH AND INVESTMENT ACTIVITY

CITY INVEST #	STATED	BROKER	SECURITY DESCRIP	FDIC #	CUSIP	PRIN	PURCH	SOLD/	BV
	MAT DATE					BAL		MATURE	PRIN
						1/1/2025	2025	2025	12/31/2025
210301	8/1/2028	UBS	SAN JOSE CA FING AUTHO		79818186P30	1,000,000.00		0.00	1,000,000.00
201007	8/1/2028	UBS	SAN BERNARDINO CALIFORN UNIV TAX		796711H44	1,000,000.00		0.00	1,000,000.00
191108	8/1/2028	UBS	CORONA-NORCO CAL		219764SC2	405,000.00		0.00	405,000.00
210825B	8/15/2028	UBS	NEW HAMPSHIRE MUNI		64465QHA7	550,000.00		0.00	550,000.00
210825A	8/25/2028	UBS	CD-CELTIC BANK	57056	15118RWG8	245,000.00		0.00	245,000.00
210326	9/1/2028	UBS	CHINO CALIF PUB FING		169548FP4	615,000.00		0.00	615,000.00
200320	9/1/2028	UBS	PENNSYLVANIA UNIV TAX		709235P25	425,000.00		0.00	425,000.00
191212	10/1/2028	UBS	UNIVERSITY OF ALABAMA TAX		914745GG2	400,000.00		0.00	400,000.00
210224B	11/1/2028	UBS	WILL COUNTY ILL COMMUNITY		969078QN7	2,500,000.00		0.00	2,500,000.00
191024	2/1/2029	UBS	PULASKI COUNTY		745401EGO3	400,000.00		0.00	400,000.00
211231	3/15/2029	UBS	NEW YORK STATE URBAN DEV		650036AX4	500,000.00		0.00	500,000.00
220207B	4/1/2029	UBS	BAY AREA CA TOLL AUTHORITY		072024XF4	250,000.00		0.00	250,000.00
210113	5/1/2029	UBS	NYC TRANSITIONAL		64971XSZ2	1,000,000.00		0.00	1,000,000.00
210617B	6/1/2029	UBS	ORANGE COUNTY TAX		684184TC8	110,000.00		0.00	110,000.00
210308A	6/1/2029	UBS	RIO RANCHO NEW MEXICO TAX		767169ER2	500,000.00		0.00	500,000.00
200630A	7/1/2029	UBS	NEW YORK STATE DORM AUTH		64990GS86	430,000.00		0.00	430,000.00
200611	11/1/2029	UBS	VENTURA COUNTY CA		923078CZ0	400,000.00		0.00	400,000.00
210114	12/1/2029	UBS	FRANKLIN COUNTY OH		353174JE6	1,000,000.00		0.00	1,000,000.00
200324	3/1/2030	UBS	NEW YORK CITY TAXABLE		64966QJL5	500,000.00		0.00	500,000.00
211014	5/1/2030	UBS	ST. JOHN'S PUBLIC SCHOOL		790450HN3	550,000.00		0.00	550,000.00
210604	7/1/2030	UBS	FLORIDA STATE BOARD TAX		341271AF1	1,000,000.00		0.00	1,000,000.00
200921	7/1/2030	UBS	FLORIDA STATE REV BOND		341271AF1	500,000.00		0.00	500,000.00
210910	9/1/2030	UBS	BROWNSVILLE TX UTIL		1164753D4	1,000,000.00		0.00	1,000,000.00
101013	12/1/2030	UBS	HIDALGO COUNTY TEX TAX		429343BT3	500,000.00		0.00	500,000.00
201102	12/1/2030	UBS	XENIA OH COMM SCHOOL		984071CC2	720,000.00		0.00	720,000.00
210107	6/1/2031	UBS	SAN JOSE CA FING AUTHO		798153NL2	1,000,000.00		0.00	1,000,000.00
210111	6/1/2031	UBS	SAN JOSE CA FING AUTHO		798153NL2	320,000.00		0.00	320,000.00
211020B	8/15/2031	UBS	ALABAMBA FEDERAL AID HWY		010268CT5	500,000.00		0.00	500,000.00
200417	9/1/2031	UBS	CITY OF NORFOLK VA TAX		655867G94	220,000.00		0.00	220,000.00
211115	10/1/2031	UBS	INFRASTRUCTURE BANK		76223MAL6	580,000.00		0.00	580,000.00
211209	9/15/2032	UBS	CAPE MAY COUNTY NJ TAX		139501SB7	470,000.00		0.00	470,000.00
250131		UBS	UBS TREASURY FUND (FORMERLY PRIME)				47,573.90	0.00	47,573.90
250731a		UBS	UBS TREASURY FUND (FORMERLY PRIME)				3,565,046.21	0.00	3,565,046.21
260630		UBS	UBS TREASURY FUND (FORMERLY PRIME)				1,596,228.67	0.00	1,596,228.67
240630		UBS	UBS TREASURY FUND (FORMERLY PRIME)			102,943.99		102,943.99	0.00
240731A		UBS	UBS TREASURY FUND (FORMERLY PRIME)			554,746.42		554,746.42	0.00
240228		UBS	UBS PRIME FUND			266,327.95		266,327.95	0.00
240831A		UBS	UBS TREASURY FUND (FORMERLY PRIME)			58,423.28		58,423.28	0.00
241231		UBS	UBS TREASURY FUND (FORMERLY PRIME)			10,866,656.35		6,303,413.19	4,563,243.16
									<u>48,587,091.94</u>
TOTAL INVESTMENTS						72,720,097.99	20,673,848.78	21,126,854.83	72,267,091.94
Unamortized Premiums						1,759,475.03			1,759,475.03
Unamortized Discounts						(4,343,552.11)			(4,343,552.11)
BMO						3,772,752.20	37,409,178.44	38,394,072.33	2,787,858.31
Bond Proceeds						2,211,399.18	3,610.76	2,215,009.94	-
Money Market Accounts						12,726,157.62	12,686,106.92	14,000,000.00	11,412,264.54
Net Cash and Investments						88,846,329.91	70,772,744.90	75,735,937.10	83,883,137.71

CC Regular Session

Meeting Date: 08/12/2025

Primary Strategic Plan Initiative: Not Applicable

Title:

Note the following Boards, Commissions and Meeting Minutes:

- Planning Commission Meeting Minutes - June 26, 2025
- Economic Development Authority - May 8, 2025
- Public Works Meeting Minutes - June 17, 2025
- Park and Rec Commission Meeting Minutes - June 12, 2025

Purpose/Background:

Approve the Meeting Minutes

Recommendation:

Approval

Outcome/Action:

Approval

Attachments

- PC June 2025 Minutes
- EDA May 2025 Minutes
- P & R June 2025 Minutes
- PWC June 2025 Minutes

Form Review

Inbox	Reviewed By	Date
Mariah Albrecht	Mariah Albrecht	07/31/2025 02:08 PM
Brian Hagen	Brian Hagen	08/07/2025 03:49 PM
Brian Hagen	Brian Hagen	08/07/2025 03:50 PM
Form Started By: Kalia Lor		Started On: 07/29/2025 02:05 PM
Final Approval Date: 08/07/2025		

**PLANNING COMMISSION
CITY OF RAMSEY
ANOKA COUNTY
STATE OF MINNESOTA**

The Ramsey Planning Commission conducted a regular meeting on Thursday, June 26, 2025, at the Ramsey Municipal Center, 7550 Sunwood Drive NW, Ramsey, Minnesota.

Members Present: Chairperson Cheri Gengler
 Commissioner Bruce Anderson
 Commissioner Randy Bauer
 Commissioner Jeffrey Lubarski
 Commissioner Debra Musgrove (left at 9:07 p.m.)
 Commissioner Nichole Rudack
 Commissioner Gary VanScoy

Members Absent: None

Also Present: Planning Manager Todd Larson (left at 8:05 p.m.)
 City Planner Adam Martin
 City Council Liaison Eric Peters

1. CALL TO ORDER

Chairperson Gengler called the regular meeting to order at 7:00 p.m.

2. PLEDGE OF ALLEGIANCE

Chairperson Gengler led the group in the Pledge of Allegiance.

3. CITIZEN INPUT

None.

4. APPROVAL OF AGENDA

Motion by Commissioner Lubarski, seconded by Commissioner Musgrove, to approve the agenda as presented.

Motion Carried. Voting Yes: Chairperson Gengler, Commissioners Lubarski, Musgrove, Anderson, Bauer, Rudack, and VanScoy. Voting No: None. Absent: None.

5. CONSENT AGENDA

5.01: Approve the May 22, 2025, Planning Commission Meeting Minutes

Motion by Commissioner Musgrove, seconded by Commissioner Rudack, to approve the consent agenda as presented.

Motion Carried. Voting Yes: Chairperson Gengler, Commissioners Musgrove, Rudack, Anderson, Bauer, and Lubarski. Voting No: None. Abstaining: Commissioner VanScoy. Absent: None.

6. PUBLIC HEARINGS/COMMISSION BUSINESS

6.01: Public Hearing: Consider a Conditional Use Permit, Site Plan, and Variance for Drive-Through in the Front Yard in the COR-2b Zoning District for Chipotle at 14701 Armstrong Blvd NW

Public Hearing

Chairperson Gengler called the public hearing to order at 7:02 p.m.

Presentation

City Planner Martin presented the staff report stating that staff recommend approval of the Conditional Use Permit, Site Plan, and Variance.

Commissioner VanScoy asked if there would be plans to extend the fence the length of the driveway along Sunwood.

City Planner Martin replied that staff had discussions with the applicant related to items that could be within the easement area. He stated that the location of the underground pipe would prevent the fence from going too much farther to the west.

Commissioner VanScoy asked if a variance is requested from the framework requirement.

City Planner Martin replied that a variance from the framework requirement was not requested.

Commissioner Lubarski referenced the crosswalk with two-way traffic and asked if there would be a mirror to provide safer crossing.

City Planner Martin replied that it is one-way traffic and there would be signs for the crosswalk to alert drivers.

Commissioner Bauer stated that it is his understanding that the fence was a safety barrier between the sidewalk and traffic, and therefore agreed with Commissioner VanScoy that the fencing should be extended.

Commissioner Anderson recognized that the City does not like bare walls and asked if there have been conversations to improve the aesthetic of that wall.

City Planner Martin commented that staff have worked with the applicant to elevate the design of the building and materials. He stated that it was preferred to have windows directly along the pedestrian network and patio.

Commissioner Anderson noted that Aldi used fake windows on the backside and asked if there have been conversations to incorporate something like that.

Citizen Input

Allison Morgan, Capital Real Estate, spoke on behalf of the applicant and stated that their initial proposal had an EIFS façade and did not meet the COR standards. She explained that they worked with staff to come to this proposal. She stated that they could explore additional options with staff if the Commission desires to have additional changes to that elevation.

Commissioner Musgrove asked if the applicant had considered downward-facing decorating lighting. She commented that could help break up that façade and could improve the safety of pedestrians as well.

Ms. Morgan replied that they could consider decorative lighting. She commented that there would be downward-facing lighting on the building, but they could replace that with decorative lighting.

City Planner Martin noted that this building will be much smaller than Aldi and was unsure that additional windows would be needed, or fit. He commented that for a quick service restaurant, this building has many more windows than would be typical. He noted that the bathrooms and kitchen are along that back wall. He stated that staff have reviewed the lighting plan, and it meets the requirements of the City Code. He stated that adding additional lighting may cause problems in the review.

Commissioner Anderson stated that he wants to ensure they are consistent within the City, noting that they asked Aldi to do something with their back wall, and they did. He stated that this seems to be a similar situation, and everyone coming down Sunwood would see that side of the building. He asked how tall the fence would be that is proposed along that area.

Ms. Morgan stated that the proposed fence would be 36 inches high and would be decorative and ornamental, matching what was approved for the Taco Bell site. She commented that it is positioned in the proposed location to achieve a corner feature to anchor the development to Sunwood and Armstrong. She commented that the lot is wider than a standard lot in order to get to the roundabout, and therefore, continuing the fence would take away from creating that corner feeling.

City Planner Martin stated that staff measured the long wall of the building, which is 70 feet, compared to the 210 feet of the long wall for Aldi. He stated that the fence would be three feet, which was approved for Taco Bell and provides a hard edge for the site. He stated that the building will be about 20 feet tall. He stated that there is 90-degree angled parking along the north side of

the drive aisle and no parking along the stretch of Sunwood Drive. He commented that there is a ten-foot setback from the sidewalk to the curb, with vegetation planned between.

Commissioner Musgrove stated that she is fine with the fencing as proposed and trusts that staff and the applicant would develop a nice-looking area for this entrance into Sunwood. She recognized that the purpose of the fencing is decorative rather than safety. She commented that vehicles will be driving slowly through the drive aisle, and there is space between the roadway and sidewalk. She referenced the proposed placement of a pylon sign near the drive aisle, but recognized that there will not be ordering done in the drive aisle and asked for clarification on the purpose of that sign.

Ms. Morgan replied that the pylon sign is a 25-foot-tall Chipotle sign, which is located close to the building because of the stormwater easements adjacent to Armstrong. She stated that there would be a sign for the Chipotle pick-up lane, and there is a bypass lane for those who may have thought they could order in the pick-up lane.

Commissioner VanScoy referenced the COR framework related to screening of parking areas and believed the entire area should be screened.

Ms. Morgan stated that typically when they lay out site plans, they view parking adjacent to the road to be parking where headlights would shine onto the roadway, and would not view this to be that situation. She commented that there is landscaping planned along Sunwood.

Commissioner VanScoy commented that the intent of the COR framework is for aesthetics and not for screening headlights.

Councilmember Peters asked if the applicant would be open to entertaining a fence.

Ms. Morgan commented that she could discuss that with her team.

Commissioner VanScoy commented that the screening could be done with shrubs as well.

City Planner Martin stated that the landscaping plan was included in the packet, noting the trees that are planned in addition to the boulevard trees.

Ms. Morgan commented that they could continue the discussion with staff to perhaps add shrubs.

Planning Manager Larson stated that staff can work with the applicant to address that prior to the City Council meeting.

Commissioner Musgrove commented that it would seem landscaping would seem to be the better choice if the intent is to screen the parking.

City Planner Martin commented that staff have worked with the applicant to find the best solution, as this is a very long lot line from Armstrong past the roundabout, along with the location of the large easement. He noted that this is a hybrid district between the urban and suburban designs.

Commissioner Anderson asked about the type of shrubbery proposed.

City Planner Martin replied that a typical landscape plan, at this level of detail, requires large trees, small trees, and shrubs rather than getting into the detail of species. He noted that shrubs are planned along the wall.

Commissioner Anderson stated that his concern was not with the species but the height of the shrub. He noted that if the height of the shrubs were three feet tall, that would alleviate the concern with the appearance of the wall.

City Planner Martin noted that this design is consistent with the Taco Bell design that was unanimously approved last month, within the same development. He stated that the goal is to have consistency and cohesion between the three lots while also meeting the standard of the zoning district.

Commissioner Anderson stated that he just wants to ensure that each developer is held to the same standards as previous developers within the COR. He stated that if the shrubs are about three feet, he would be fine with the appearance of the wall.

Chairperson Gengler stated that this is a beautifully designed building and a great product for the COR.

Motion by Commissioner Bauer, seconded by Commissioner Musgrove, to close the public hearing.

Motion Carried. Voting Yes: Chairperson Gengler, Commissioners Bauer, Musgrove, Anderson, Lubarski, Rudack, and VanScoy. Voting No: None. Absent: None.

Chairperson Gengler closed the public hearing at 7:37 p.m.

Commission Business

Motion by Commissioner Bauer, seconded by Commissioner Musgrove, to adopt Resolution #25-149 Granting a Variance for a Drive-Through Lane in the Front Yard for Chipotle at 14701 Armstrong Boulevard NW.

Motion Carried. Voting Yes: Chairperson Gengler, Commissioners Bauer, Musgrove, Anderson, Lubarski, Rudack, and VanScoy. Voting No: None. Absent: None.

Motion by Commissioner Lubarski, seconded by Commissioner Rudack, to recommend City Council adoption of Resolution #25-148 Approving a Conditional Use Permit for a Drive-Through Lane and a Site Plan Review for Chipotle at 14701 Armstrong Boulevard NW.

Further discussion

Commissioners discussed whether additional screening should be required along the parking area, east of the fence, to maintain separation, and along the south wall of the building. An additional condition was added through friendly amendment to ask the City Council to consider proper screening of the parking and along the southern wall of the building. Additional discussion ensued as to whether the decorative fencing should be extended, but it was determined that an extension would not be needed as the fencing is decorative in nature and would not provide screening.

Motion Carried. Voting Yes: Chairperson Gengler, Commissioners Lubarski, Rudack, Anderson, Bauer, and VanScoy. Voting No: Commissioner Musgrove. Absent: None.

7. COMMISSION BUSINESS

7.01: “Brookside Terrace” Sketch Plan – Six Lot Subdivision at 15156 Nowthen Boulevard NW (Brookside Construction Inc.)

Presentation

Planning Manager Larson presented the Staff Report stating that the Commission is asked to provide comments and direction for the applicant so that the detailed preliminary plat plans can be prepared for an upcoming application date. He noted that three letters had been submitted by residents that have been provided to the Commission tonight.

Jason Rud, land surveyor, spoke on behalf of the applicant and stated that he was present to address any questions.

Commissioner Bauer asked and received confirmation that this property is zoned for 80-foot lots. He stated that the sketch plan shows all six lots meeting and/or exceeding that lot width with fewer lots than would be recommended for that size parcel.

Planning Manager Larson commented that it would be difficult to deny something that meets all Code requirements. He stated that the discussion would focus on whether there should be an additional connection to Armstrong.

Mr. Rud commented that the lot depth is what creates the issue with the density being lower. He stated that if a lot could front on Nowthen Boulevard, they could have a seventh lot, but recognized that the County would not provide permission for a lot to front onto their roadway.

Planning Manager Larson stated that the cities are allocated a certain number of units, and density can be allocated across the land. He stated that the City sets the range, and, in the end, the average density needs to be met in accordance with the requirements of the Metropolitan Council.

Commissioner Rudack asked if the developer could be asked to reduce lots to five to meet the density.

Planning Manager Larson replied that two more lots would actually be needed to meet the density. He stated that this could be rezoned to allow smaller lot sizes, but that would be inconsistent with the neighborhood. He noted that other projects in the community will balance out the density.

Commissioner Rudack asked if traffic has been factored into the review.

Planning Manager Larson commented that these additional lots are a drop in the bucket for traffic on Nowthen Boulevard.

Commissioner Lubarski asked if the grading for lots one and two would impact the existing neighbor.

Mr. Rud explained that there is a dedicated drainage easement on the westerly side of the parcel, which was platted prior to the street reconstruction in 1995. He stated that storm sewer and curb and gutter were added during that road project, and the drainage easement is no longer needed in that location. He stated that they will be held to strict drainage requirements and will provide onsite ponding to handle the stormwater. He stated that the goal would be to preserve trees, as this is a custom home builder.

Commissioner Musgrove asked if the developer has tried other layout patterns that would not have as many entrances onto 151st.

Mr. Rud stated that when the construction plan was created for the road in 1995, it included similar lot lines. He stated that a portion of the sewer and water services were stubbed consistent with that, and they are following that pattern. He stated that they did not consider creating additional streets as they would need to clear-cut the site, and that is not the desired intent.

Commissioner Bauer asked if the homes planned would be consistent with the neighborhood.

Mr. Rud replied that building elevations have not yet been created. He estimated that these would be midrange homes with nice homes.

Chairperson Gengler recognized that this is not a public hearing but welcomed input from the residents in attendance.

Steve Croteau, 5939 151st Lane, stated that he and his wife purchased their 2.5-acre parcel in 1990 to have some space. He commented that since that time, sewer and water were added, which allowed further subdivision. He stated that there are currently 39 single-family homes with only one point of ingress and egress to Nowthen Boulevard. He believed that adding six additional homes would create a safety concern. He commented that this area is just north of the elementary school, and during events, they often experience people parking on both sides of 151st, which adds to his concerns for safety. He commented that the lots appear to be 80 feet in width with a five-foot setback and asked if that means homes could be ten feet apart.

City Planner Martin commented that he has not been working on this project, but will take over as Planning Manager Larson had to leave the meeting. He stated that the zoning for this property is the same designation as the entire neighborhood; therefore, the homes all have the same setback.

Mr. Croteau stated that there are more than ten feet between homes that exist in the neighborhood.

City Planner Martin commented that setbacks change over time with zoning code updates. He stated that the setback would allow existing residents to build an addition onto their homes as long as the setbacks are met.

Mr. Croteau stated that with a five-foot setback on each side that would allow for a 60-foot-wide footprint. He asked about the type of home that would be constructed, as this neighborhood does not have cookie-cutter homes like those in Riverstone and some of the other developments.

City Planner Martin provided information on the lot sizes in Riverstone and the Preserve at Northfork. He stated that it would be a challenge to fit lots that would meet both the minimum lot width and density.

Chairperson Gengler noted that the developments mentioned by the resident contain 80-foot lots as well as smaller lots, whereas these lots would all have a minimum lot width of 80 feet.

Mr. Croteau stated that this would be inconsistent with what exists in the neighborhood. He asked what residents and neighbors could do to oppose this development, such as a petition.

Commissioner Bauer commented that the proposal meets the zoning requirements and therefore the City would have a hard time denying the right for the applicant to develop in a manner that meets City Code. He stated that review is done by various departments related to access, but the role of the Commission is to verify that the plat meets the proper requirements.

Chairperson Gengler stated that the residents voicing their concerns is helpful with the continued review and discussions on the project.

Mr. Croteau stated that if the number of lots were reduced to three or four, it would be better supported by the residents and more consistent with the neighborhood.

City Planner Martin commented that most of the lots in this development are 80 feet wide, which is also the minimum requirement of the City Code for the zoning district. He noted that this zoning district has the lowest density within the MUSA. He stated that this is the lowest level of development that could be proposed.

Chairperson Gengler asked for more information on the property on the Quicksilver cul-de-sac. It was noted to be a bike trail.

Chris Weiss, 5907 151st Lane, stated that they have struggled for a number of years with drainage on his property. He stated that if this area is developed, they would need to do something significant to ensure that his property does not endure the drainage from that area.

City Planner Martin stated that there are a few points of review for stormwater throughout this process, noting that stormwater ponding will be required on this site.

Commissioner Bauer asked if parking is allowed on both sides of 151st with room for vehicles to travel.

City Planner Martin confirmed that the street is 66 feet wide, which is typical.

Commissioner Bauer referenced the comment from the resident related to overflow parking occurring on the roadway and asked if one side should be posted as no parking.

City Planner Martin commented that the Police Department would handle those comments and could address parking complaints if they arise.

Commissioner Musgrove commented that if people are parking on both sides of the road, that causes people to walk in the road, which can cause concerns for safety. She stated that she is not concerned with the lower density as proposed, as that can be offset by the density of other developments. She referenced lot six, which is wider than the other lots, noting that the four lots in the middle seem to be narrower. She asked if lots one and two could be combined, which would help to preserve trees, reduce the amount of fill needed, and assist with drainage. She noted that she is trying to find a balance between property rights and the concerns of the neighbors.

City Planner Martin stated that the density with six lots is as low as this site could develop and stated that additional lots could not be eliminated. He stated that the applicant and staff have worked diligently to find a development proposal that would meet the spirit and intent of the Code and same standard of the neighborhood.

Councilmember Peters agreed with staff's comments. He noted that lot six is wider because of the setback from Nowthen Boulevard.

Ben Tronson, 5954 151st Lane, echoed the concerns with safety. He referenced a new home that was built on the corner, which often has vehicles parked on the road, which limits visibility. He commented on the difficulty of turning onto Nowthen Boulevard. He commented that building homes that will be consistent with the neighborhood on those lots would not leave much room for parking, which would cause additional vehicles to be parked on the road. He stated that there is a lot of bicycle and pedestrian traffic in the neighborhood, with the bike trail, and when vehicles are parked on the road, the pedestrians are forced to walk or bike further into the road. He stated that any time there is rain, there is a giant puddle on the exit lane at the entrance to the development. He stated that the road is in poor condition and construction traffic will only cause further deterioration.

Jason Kawecki, 15200 Nowthen Boulevard, commented that he purchased his property in 2016, and he did not anticipate that his life would change when his neighbor placed his property for sale, as he did not anticipate that the property would be subdivided. He stated that because of grading changes, even with a ten-foot fence, they would still see from their backyard into all the new

backyards. He referenced the 52-foot-wide strip of property within the applicant's narrative that states it could be sold to the neighbor for future development, but stated that he has not heard anything about that. He stated that there are plans for his property showing cul-de-sacs, of which he was not aware.

Chairperson Gengler commented that can be intentional thought into preserving a buffer of trees between properties in development.

Commissioner Anderson asked if there would be a possibility that they could restrict the parking to one side of the road, as that could potentially ease some of the safety concerns of the neighbors.

City Planner Martin referenced the comments related to the condition of the road, which are valid concerns that can be brought to the attention of the Engineering and Public Works Departments.

Tom Sparrow, 5900 151st Lane NW, stated that a great majority of their traffic occurs during the school year. He stated that every morning and afternoon, their street is filled with cars and kids. He believed that adding six additional homes would increase the problem with safety. He commented that there are issues with sight as people come in and out of the neighborhood because of the grades. He was unsure that it would be feasible to restrict parking to one side and noted that building an additional six homes would take up space for the parents and children using the road during the school year.

Commissioner Bauer asked to see a map showing the neighborhood in relation to the school and asked about the location of the nearest stoplight.

City Planner Martin displayed the map, noting the nearest signalized intersection is at Alpine to the north. He stated that the school is just to the south, and most likely, people are parking on the street and walking along the trail to get to the school. He stated that if there are concerns with overflow parking from the school, staff could bring that up to the School District during the review process. He noted that the school property would have room to add additional parking if needed.

Chairperson Gengler stated that people might park on that street during drop-off/pick-up times and have their child walk to avoid the school traffic. She commented that they could discourage that activity at the school.

Commissioner Bauer asked if the County would consider a temporary stoplight at the intersection during busy times.

City Planner Martin replied that the Anoka County Highway Department will be part of the review process. He noted a traffic study that has recently been completed for Nowthen Boulevard, for a 400-unit development, compared to six lots.

Sara Narr, 6100 151st Lane, stated that in 2020, their home burned down, and there is only one access for the development. She stated that another home had burned down as well, and prevented access into and out of the neighborhood for several hours. She stated that when they rebuilt their home, the cul-de-sac was basically shut down with dumpsters and other equipment, which

impacted the ability of buses to turn around. She stated that this is an amazing street that is very picturesque, but does not have great visibility and safety. She also disagreed with restricting parking to one side, as the neighborhood also uses the road for parking. She stated that she would prefer two or three homes rather than six. She commented that when she leaves for work in the morning, it can take ten minutes to get onto Nowthen Boulevard because of traffic. She asked that the City consider aesthetics for their neighborhood the same way it does for Chipotle and development within the COR. She commented on the placement of the bike trails and asked that the Commission consider the issue of safety.

Jean Pierre Ngo, 6000 151st Lane NW, commented that he has lived at his property for over 30 years and considers it to be a quiet area. He expressed concerns about safety if six more lots were added.

City Planner Martin commented that they have received sufficient feedback for this stage of the development process. He recognized that change can be difficult and thanked the residents for attending and providing their input tonight.

Commissioner Musgrove stated that perhaps shared driveways could be used to minimize the connection points onto 151st.

Commissioner VanScoy stated that the main issue seems to be with safety, and the primary concern behind that seems to be the single access point onto a busy roadway. He did not see a way to improve that situation with this proposed development. He asked what the City could do to ensure at some point that could be addressed.

City Planner Martin noted a second potential access that would go to Alpine, as mentioned in the earlier presentation, and advised that would be dependent upon development of the properties to the north.

Commissioner Bauer commented that it would seem difficult to connect a road from Alpine to 151st because of the wetland.

City Planner Martin identified the path a connecting roadway could take and noted that if that connection is desired, this would be the time to plan for it.

Chairperson Gengler acknowledged that planning for the connection would include a cul-de-sac or stub on the developing property and would not have any impact on the properties to the north.

City Planner Martin confirmed that would provide the right-of-way within the plat to get a street through, but there would be a possibility that it would never be built if the properties to the north chose not to develop in the future.

Commissioner Musgrove asked if the plan for the street would change the number of lots.

City Planner Martin commented that could rearrange the placement of the lots, but six lots would remain the minimum number of lots for this development.

Commissioner Anderson thanked all the residents who attended and provided input tonight, noting that this information will be helpful at this stage of the development process. He stated that the developer will now spend a lot of money to develop a preliminary plat, which will include a public hearing. He stated that the residents can also provide their written comments to the City staff. He commented that some things cannot be changed because the proposal meets the requirements of the City Code.

Commissioner Bauer commented that he would like to see an option for a second access be part of the discussion moving forward.

Commissioner Musgrove stated that the location of the second entrance may not be meaningful in that location. She stated that perhaps there could be another option for an access where the trail is located.

Commissioner Bauer commented that it would appear that the wetlands would prevent anything further west from being constructed.

Councilmember Peters commented that to the west, there is another neighborhood with one access. He stated that there should not be neighborhoods with just one access and lack of sidewalks. He stated that he lives in a neighborhood with 80-foot lots, and he has 20 feet on one side and ten feet on the other side. He believed that this was a poorly developed neighborhood long ago.

Chairperson Gengler thanked everyone who attended and provided input tonight.

Commissioner Musgrove left the meeting at 9:07 p.m.

8. COMMISSION / STAFF INPUT

The Staff Update was noted.

Chairperson Gengler noted that there will not be a July meeting.

9. ADJOURNMENT

Motion by Commissioner Bauer, seconded by Commissioner Anderson, to adjourn the meeting.

Motion Carried. Voting Yes: Chairperson Gengler, Commissioners Bauer, Anderson, Lubarski, Rudack, and VanScoy. Voting No: None. Absent: Musgrove.

The regular meeting of the Planning Commission adjourned at 9:08 p.m.

Respectfully submitted,

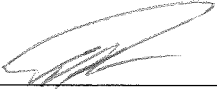

Todd Larson
Planning Manager

ATTEST:

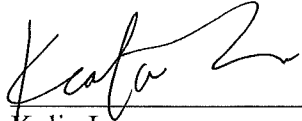

Kalia Lor
Planning Administrative Assistant

Drafted by Amanda Staple
TimeSaver Off Site Secretarial, Inc.

**ECONOMIC DEVELOPMENT AUTHORITY
CITY OF RAMSEY
ANOKA COUNTY
STATE OF MINNESOTA**

The City of Ramsey Economic Development Authority (EDA) conducted a regular meeting on Thursday, May 8, 2025, at the Ramsey Municipal Center, 7550 Sunwood Drive NW, Ramsey, Minnesota.

Members Present: Chairperson Scott Wiyninger
 Member Hannah Karpen
 Member William MacLennan
 Member Chris Riley
 Member Shanna Stewart

Members Absent: Member Rachal Johnson
 Member Brittany Lindahl

Also Present: Sean Sullivan, Economic Development Manager

1. CALL TO ORDER

Chairperson Wiyninger called the Economic Development Authority meeting to order at 7:30 a.m.

2. APPROVE AGENDA

Motion by Member MacLennan, seconded by Member Stewart, to approve the agenda.

Motion carried. Voting Yes: Chairperson Wiyninger, Members MacLennan, Stewart, Karpen, and Riley. Voting No: None. Absent: Members Johnson and Lindahl.

3. CONSENT AGENDA

3.01: Approve Meeting Minutes Dated April 10, 2025

Motion by Member MacLennan, seconded by Member Karpen, to approve the April 10, 2025, minutes as presented.

Motion carried. Voting Yes: Chairperson Wiyninger, Members MacLennan, Karpen, Riley, and Stewart. Voting No: None. Absent: Members Johnson and Lindahl.

4. EDA BUSINESS

4.01: Consider Approval of Purchase Agreement and Right of Re-Entry Agreement for Lot 1, Block 7, Waterfront Village; Roers Acquisitions LLC

Economic Development Manager Sullivan presented the staff report.

Nick Asta, Roers Companies, provided background information on the experience that Roers has in development throughout the metro area. He commented that Roers has been focusing on second and third-ring suburbs in the last five years, and they continue to follow the growth north. He stated that Roers is excited about the activity and development occurring within the COR in Ramsey. He stated that this project would be 193-unit market-rate apartments ranging from studio to three-bedroom units, and provided an overview of the amenities and comparable projects they have recently completed.

Member Riley asked for information on the planned façade of the building that would face the roundabout.

Mr. Asta commented that they do have a nice grand corner entrance, but welcomed any additional input the EDA may have.

Member Stewart asked where the dog run would be located.

Mr. Asta commented that is near the entrance to the garage on the east edge of site.

Economic Development Manager Sullivan provided a sketch of the proposal and identified the location of the planned amenities, pool and dog run.

Member Stewart asked if there would be sidewalks on Zeolite.

Economic Development Manager Sullivan was unsure. However, he stated that currently there is a sidewalk that runs along the east boundary of the hotel on Zeolite, and would assume it would continue down Zeolite.

Chairperson Wyingner referenced the due diligence period and asked the percentage of projects that go through to the closing table versus stall out during that period.

Mr. Asta replied that is difficult to answer, noting that most of the time, when a project does not move forward, it is because the City voted it down. He stated that Roers has internally vetted the project on its side. He noted the reviews that are done within the due diligence period and noted that this longer period will allow them to ensure they can secure building permits at the time of closing, which means they would not need to worry about a right of re-entry.

Chairperson Wyingner asked if Roers holds, maintains, and manages properties they develop or whether they sell them once they are developed.

Mr. Asta replied that the business model of Roers is to hold properties for the first ten years, but they do have a long-term hold business model. He commented that there are instances when they have had opportunities to sell and they accepted the offer.

Member Karpen asked the projected opening date if all approvals have been gained.

Mr. Asta estimated that if all approvals are gained, they would plan to open three years from today. He believed that timeline would provide sufficient buffers, so it could open earlier than that date.

Member Stewart asked the vacancy rate on the other properties they manage and operate.

Mr. Asta explained that about 50 percent of their projects are affordable housing projects, which is different than market rate, amenity rich rental project proposed for Ramsey. He stated that generally they have 92 percent occupancy but recognized there are many variables.

Member MacLennan referenced the retail space and asked if that has been done in other Roers buildings, and if so the type of businesses that typically go into those spaces.

Mr. Asta replied that it is very typical for them to have 5,000 to 10,000 square feet of retail and explained that the user ranges, noting a current project that has a bank and restaurant. He stated that the market varies based on location and the retailers that are interested in. He noted that they plan for active uses that the residents will enjoy as an amenity. He stated that the retail space would be located in the southwest corner.

Member Karpen asked the type of parking that would be available for the retail space.

Economic Development Manager Sullivan commented that the proposed site plan includes more than enough parking for the site between the surface and underground parking and there would most likely be some stalls marked for retail use during certain hours. He stated that there is also a hotel next door and patrons of the building may walk over to the retail space.

Motion by Member MacLennan, seconded by Member Karpen, to recommend City Council approval of Purchase Agreement and Right of Re-Entry Agreement as presented; subject to City Attorney review.

Motion carried. Voting Yes: Chairperson Wyingner, Members MacLennan, Karpen, Riley, and Stewart. Voting No: None. Absent: Members Johnson and Lindahl.

5. MEMBER / STAFF UPDATE

Economic Development Manager Sullivan commented on the success of the recently held Business Expo, noting the positive feedback he has received from vendors. He also provided a brief update on development projects within the City pipeline, as well as the interest he has received for additional investment in Ramsey. He believed the June EDA meeting would likely be canceled.

Chairperson Wyingner thanked staff for the great work on the Business Expo.

6. ADJOURNMENT

Motion by Member Karpen, seconded by Member MacLennan, to adjourn the meeting.

Motion carried. Voting Yes: Chairperson Wiyninger, Members Karpen, MacLennan, Riley, and Stewart. Voting No: None. Absent: Members Johnson and Lindahl.

The regular meeting of the Economic Development Authority adjourned at 7:58 a.m.

Respectfully submitted,



Sean Sullivan
Economic Development Manager

ATTEST:



Wendy Schlueter
Economic Development Administrative Assistant
p

Draft by Amanda Staple
TimeSaver Off Site Secretarial, Inc.

**PARK AND RECREATION COMMISSION
CITY OF RAMSEY
ANOKA COUNTY
STATE OF MINNESOTA**

The Ramsey Park and Recreation Commission conducted a regular meeting on June 12, 2025, in the Lake Itasca Room at The City Hall, 7550 Sunwood Drive NW, Ramsey, Minnesota.

Commission Members Present: Chair Megan Ealain
 Vice Chair Nathan Barten
 Commissioner Garth Anderson
 Commissioner Todd Arts
 Commissioner Shane Bennett
 Commissioner Dean Olson
 Commissioner Brandon Sis

Commission Members Absent:

Also Present: City Council Liaison Kirsten Buscher
 Parks & Assistant Public Works Director Mark Riverblood
 Recreation Coordinator Abby Proulx

1. CALL TO ORDER

Chair Ealain called the Park and Recreation Commission meeting to order at 6:38 p.m.

2. CITIZEN INPUT

None.

3. APPROVE AGENDA

Motion by Commissioner Barten, seconded by Commissioner Sis, to approve the Park and Recreation Commission meeting agenda as presented.

Motion carried. Voting Yes: Chair Ealain; Commissioners Barten, Sis, Anderson, Arts, Bennett, and Olson. Voting No: None. Absent: None.

4. APPROVE MINUTES

4.01: Approve Park and Recreation Commission Meeting Minutes

Commissioner Sis noted that he was not at the meeting and should be listed as absent.

Motion by Commissioner Bennett, seconded by Commissioner Barten, to approve the following Park and Recreation Commission Regular Meeting Minutes as amended:

- Park and Recreation Commission Meeting Minutes dated May 8, 2025

Motion carried. Voting Yes: Chair Ealain; Commissioners Bennett, Barten, Anderson, Arts, Olson, and Sis. Voting No: None. Absent: None.

5. COMMISSION BUSINESS

5.01: The Waterfront – Water-Play and Eastern Park Development Process

Parks & Assistant Public Works Director Riverblood presented background information on the concept planning for The Waterfront and the progress that has been made in the past few years. He stated that residents are excited about the park and water play feature planned and have voiced support for the project. He stated that the City Council has taken action based on that support and recently authorized the work plan for the water play. He stated that tonight the Commission is asked to approve the same plan.

Parks & Assistant Public Works Director Riverblood provided additional information on the seven community parks and features throughout the parks system, which are geographically placed around the community. He noted that The Waterfront is a community park that is meant for all residents, not just those within The COR area. He recognized the cost for the water play area and the community building, noting that because of that cost, they would plan to move forward with the water play area first and follow in a later stage with the community building. He estimated a 13-month schedule, which, although aggressive, would allow for a grand opening of July 1, 2026, for the water play. He noted that the design team has begun to meet biweekly on this project and highlighted some of the details they will be working out during that planning process. He stated that the bid documents should be prepared this winter, and the bid can include liquidated damages to ensure the project is completed prior to the July 1st deadline. He hoped that the Commission could begin to review some recommendations at the July meeting.

Motion by Commissioner Bennett, seconded by Commissioner Sis, to recommend City Council approval \$268,900 from the Park Trust Fund for the next steps on the Waterfront project.

Motion carried. Voting Yes: Chair Ealain; Commissioners Bennett, Sis, Anderson, Arts, Barten, and Olson. Voting No: None. Absent: None.

Councilmember Buscher provided additional input on the information presented to the Council on this project and different elements that could potentially be added to the project, such as a wading pool. She asked that staff speak to the Council sooner rather than later, related to the community building. She noted that she has received comments in support of higher taxes in return for a community center, but realized those positions may change. She realized that the community building would not meet the same aggressive timeline as the water play, but perhaps could move forward faster than anticipated. She stated that she was not tied to the July 1st deadline and would prefer to make sure the project is completed correctly.

Commissioner Bennett commented that the phased approach could provide benefit. He noted that if the water play is opened and successful, that could bring pressure to move forward with the community building. He also noted the broader benefit to the local businesses that is created when people come from outside the community to local features.

Parks & Assistant Public Works Director Riverblood provided additional information on similar facilities in other communities that benefit from public/private partnerships between cities and companies that can assist in operating the facility. He noted additional opportunities that may be available for the City to partner with other local businesses, such as the Hilton, to provide community hours.

6. COMMISSION/STAFF INPUT

6.01: May Recreation Program Update

Parks & Assistant Public Works Director Riverblood stated that the report provides links and information on the recreational programming. He noted a grant received for \$84,000 from the Metropolitan Council for emerald ash borer replanting. He stated that at the July meeting, he will provide the Commission with additional information on the grant the City received for The Waterfront.

7. ADJOURNMENT

Motion by Commissioner Bennett, seconded by Commissioner Barten, to adjourn the meeting.

Motion carried. Voting Yes: Chair Ealain; Commissioners Bennett, Barten, Anderson, Arts, Olson, and Sis. Voting No: None. Absent: None.

The Park and Recreation Commission meeting adjourned at 7:18 p.m.

Respectfully submitted,

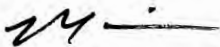

Mark Riverblood
Parks & Assistant Public Works Director

Drafted by Amanda Staple
TimeSaver Off Site Secretarial, Inc.

**PUBLIC WORKS COMMITTEE
CITY OF RAMSEY
ANOKA COUNTY
STATE OF MINNESOTA**

The Public Works Committee conducted a regular meeting on Tuesday, June 17, 2025, at the Ramsey Municipal Center, 7550 Sunwood Drive NW, Ramsey, Minnesota.

Members Present: Chairperson Michael Olson
 Councilmember Chris Riley

Members Absent: Councilmember Dan Specht

Also Present: City Engineer/Public Works Director Bruce Westby
 Assistant City Engineer Joe Feriancek

1. CALL TO ORDER

Chairperson Olson called the regular meeting of the Public Works Committee to order at 5:30 p.m.

2. CITIZEN INPUT

There was none.

3. APPROVE AGENDA

Motion by Councilmember Riley, seconded by Chairperson Olson, to approve the agenda, as presented.

Motion carried. Voting Yes: Chairperson Olson and Councilmember Riley. Voting No: None.

4. APPROVE MINUTES

4.01: Approve May 20, 2025, Meeting Minutes

Motion by Councilmember Riley, seconded by Chairperson Olson, to approve the following minutes:

Regular Meeting Minutes dated May 20, 2025

Motion carried. Voting Yes: Chairperson Olson and Councilmember Riley. Voting No: None.

5. COMMITTEE BUSINESS

5.01: Consider Recommending City Council Authorization to Prepare Plans and Specifications for 2026 Pavement Management Program Projects

Assistant City Engineer Feriancek reviewed the staff report and recommendation, which recommended City Council authorization to prepare plans and specifications for 2026 Pavement Management Program projects.

City Engineer/Public Works Director Westby commented that as they continue to work their way north, where ditches are more prevalent, they continue to receive comments related to ditches holding water for long periods of time. He stated that residents ask why stormwater utility fees are required to be paid when ditches are not being re-graded during street reconstruction projects. He stated that staff more and more frequently need to meet with property owners to discuss concerns related to ditches and potential drainage improvement projects. He stated the majority of homeowners are just happy the roads are being fixed, but that some want all of the ditches re-graded at the same time. He stated staff do add drainage improvements to street reconstruction projects, such as when there is the potential for homes to be flooded, but that wholesale re-grading of ditches are not considered. Then during construction, staff will work with property owners who voice drainage concerns on a one-on-one basis to address their concerns, if possible.

Councilmember Riley asked and received confirmation that they are continuing to address the roads in the worst condition first. He referenced a street segment that appears to be part of a neighborhood street reconstruction project and asked why that street is not included in the project.

Assistant City Engineer Feriancek replied that is a separate subdivision and the street was constructed at a different time therefore this street is scheduled for repairs within the CIP at a later date.

Motion by Councilmember Riley, seconded by Chairperson Olson, to recommend City Council authorization to prepare plans and specifications for 2026 Pavement Management Program projects.

Motion carried. Voting Yes: Chairperson Olson and Councilmember Riley. Voting No: None.

5.02: Consider Recommendation to City Council to Approve Plans and Authorize Advertise for Bid for 2025 Pavement Skim Patching Project

City Engineer/Public Works Director Westby reviewed the staff report and recommendation, which recommended City Council approval of plans and authorization to advertise for bids for a 2025 Pavement Skim Patching Project.

Motion by Councilmember Riley, seconded by Chairperson Olson, to recommend City Council approval of plans and authorization to advertise for bids for a 2025 Pavement Skim Patching Project.

Motion carried. Voting Yes: Chairperson Olson and Councilmember Riley. Voting No: None.

6. COMMITTEE / STAFF INPUT

6.01: Receive Updates on Improvement Projects, Studies, and Items of Interest

City Engineer/Public Works Director Westby provided an update on current and proposed City, County, and MnDOT improvement projects and studies, and on other items of interest to the Committee.

City Engineer/Public Works Director Westby provided additional details on the water treatment plant project and related delays.

Councilmember Riley requested monthly updates on the Waterfront splash pad project moving forward, as well as more detailed updates moving forward on the Water Treatment Plant project, the Ramsey Gateway Highway 10 project, and the 2027 MnDOT Highway 10 mill and overlay project.

City Engineer/Public Works Director Westby presented a short video clip of staff using the new 19” wood chipper on emerald ash borer infested trees removed from Peltzer Park.

6.02: Update on Minnesota Department of Transportation 2027 Highway 10 Mill and Overlay and Reduced Conflict Intersection Improvements Project

City Engineer/Public Works Director Westby stated that staff were recently made aware of a proposed Minnesota Department of Transportation (MnDOT) 2027 Highway 10 Pavement Mill and Overlay and Reduced Conflict Intersection Improvements project. He presented the information to the Committee, reviewed staff comments, and welcomed additional comments from the Committee.

Councilmember Riley commented that it makes sense to request another westbound J-turn within the City of Ramsey. He stated that while he agrees that something should be done to improve safety at these intersections, he was unsure that this was the answer, noting several problems were identified by staff.

City Engineer/Public Works Director Westby explained that Elk River has also voiced concerns with these plans.

Councilmember Riley commented that while the overlay will be a good project, this would remove a lot of access and does not seem well thought through.

City Engineer/Public Works Director Westby stated that he will continue to provide updates as more information becomes available.

6.03: Review Future Topics Calendar

City Engineer/Public Works Director Westby reviewed the future topics calendar.

City Engineer/Public Works Director Westby commented that the concrete pavement on Sunwood Drive heaved next to PSD’s office building a few years ago and provided information on two

potential repair options. The first and less costly option would be to remove as minimal a strip of concrete pavement as possible and repave the street using bituminous pavement, which would require a one-day shutdown of Sunwood Drive. The second and more expensive option would be to remove two full-width concrete pavement panels and repave them with concrete, which would require a full week shutdown of Sunwood Drive. Staff recommend the first option to allow the work to be done as soon as possible.

Councilmember Riley stated that while he would lean towards the second option, he supports the staff-recommended first option.

Chairperson Olson agreed.

7. ADJOURNMENT

Chairperson Olson adjourned the meeting.

The regular meeting of the Public Works Committee adjourned at 6:56 p.m.

Respectfully submitted,

Bruce Westby
City Engineer/Public Works Director

Drafted by Amanda Staple
TimeSaver Off Site Secretarial, Inc.

CC Regular Session

Meeting Date: 08/12/2025

Primary Strategic Plan Initiative: Enhance City’s communication through transparency and accountability.

Title

Approve the Following Meeting Minutes:

- 1. City Council Work Session dated July 22, 2025
- 2. City Council Regular Session dated July 22, 2025

Purpose/Background:

Purpose: The purpose of this case is for Council review and approval of meeting minutes.

Background: Attached are the meeting minutes referenced above.

Recommendation:

Approve the meeting minutes.

OutcomeAction:

Motion to approve the following Council meeting minutes:

- 1. City Council Work Session dated July 22, 2025
- 2. City Council Regular Session dated July 22, 2025

Attachments

- 7-22-2025 CCWS
- 7-22-2025 Meeting

Form Review

Inbox	Reviewed By	Date
Brian Hagen	Brian Hagen	08/07/2025 03:49 PM
Form Started By: Katie Schmidt		Started On: 07/29/2025 01:11 PM
Final Approval Date: 08/07/2025		

**CITY COUNCIL WORK SESSION
CITY OF RAMSEY
ANOKA COUNTY
STATE OF MINNESOTA**

The Ramsey City Council conducted a City Council Work Session on Tuesday, July 22, 2025, at the Ramsey Municipal Center, 7550 Sunwood Drive NW, Ramsey, Minnesota.

Members Present: Mayor Ryan Heineman
Councilmember Kirsten Buscher
Councilmember Michael Olson
Councilmember Eric Peters
Councilmember Chris Riley
Councilmember Dan Specht
Councilmember Shanna Stewart

Also Present: City Administrator Brian Hagen
City Engineer/Public Works Director Bruce Westby
Finance Director Diana Lund
Fire Chief Matt Kohner
Police Chief Brad Bluml
Administrative Services Director Colleen Lasher
City Attorney Fritz Knaak
Community Development Director Stephanie Hanson

1. CALL TO ORDER

Mayor Heineman called the City Council Work Session to order at 5:30 p.m.

2. TOPICS FOR DISCUSSION

2.01: Continue Discussions on Change Order #3 and Engineering Amendment #3 for Water Treatment Plant

City Engineer/Public Works Director Westby reviewed the Staff report in regard to the change order and engineering amendment for the water treatment plant project. He introduced the representatives from Advanced Engineering and Environmental Services, Inc. (AE2S), and Magney Construction, Inc. (Magney).

Councilmember Riley said he would like to hear from Magney on their need for this extension, as they only heard from AE2S at the last Council meeting.

Kevin Vranicar, Magney Construction, shared that they had an aggressive timeline with this project, and everyone underestimated the amount of time it would really take. He said he thinks they will actually come in under budget for the project. He stated they have faced numerous

challenges throughout the course of this project; however, looking at the big picture, they will likely still come in under budget for the construction.

Councilmember Riley asked if they approved what they are asking for, and if everything will be done as discussed.

Mr. Vranicar said it should be; however, construction is often uncertain, so there is a possibility that things will not go exactly as planned.

Councilmember Peters asked if all of the materials for the project have already been purchased.

Mr. Vranicar said they have ordered the piping, and it is the only thing that they do not have yet. He stated it should arrive in two to eight weeks.

Ryan Hanson, AE2S, shared that they have been meeting every two weeks with Magney to get a status update on the project.

Councilmember Buscher apologized for coming off as harsh during the last Council meeting. She said it is important that they choose to move forward at this point to finish the project well and maintain the relationships with both Magney and AE2S. She asked for better communication moving forward if they face any other challenges, so the Council can be aware if there are any other delays with the project.

Councilmember Specht noted that this request is such a small amount when it is compared to the grand total of the project. He said he will be supporting this extension request.

Mayor Heineman shared that he feels like the onus of all of these decisions is being put back on the City. He noted that the taxpayers are having to cover these mistakes, and he does not hear anything from Magney or AE2S taking any responsibility for these delays that are costing more money. He said he will not be supporting an extension since no responsibility is being taken by Magney or AE2S.

Mr. Vranicar shared that they incurred a lot of costs at the beginning of this project with the initial delay. He said they have incurred close to \$100,000 in additional costs, and by the end of the project, they will likely have absorbed an additional \$240,000 to \$300,000. He added that the City's contracts with Magney and AE2S are different contracts, and he is not aware of how the contract works with AE2S.

Mayor Heineman said these costs should have already been built into as contingencies.

City Engineer/Public Works Director Westby noted that the costs that Mr. Vranicar is referring to were outlined in the packet for the last Council meeting.

Councilmember Olson explained that they paid a higher cost up front to have the work done faster; however, he has not seen where this higher cost has benefited them.

Mr. Vranicar shared that this project was bid at a lump sum amount to have the project completed by a certain time. He noted that they had a \$50,000 credit to extend the project by four months. He said that because of this, the City could have reduced its costs by \$50,000 if they accepted this bid.

Mayor Heineman asked if they wanted the City to accept that bid, and when they did not, they promised a shorter timeline that they knew they could not meet and just took the additional money that the City was paying.

Mr. Vranicar said the shorter timeline project was the alternate bid.

Mayor Heineman asked why they would offer an alternative if they knew they would not be able to finish the project by the deadline.

Mr. Vranicar said they have incurred more than \$50,000 in additional costs on this project. He noted that the costs for engineering services are out of their control.

Councilmember Buscher stated that they have to get this project done. She added that the first delay in the project was the responsibility of the City.

Councilmember Specht noted that this is a very small percentage of the overall project cost, and he wants to make sure that they maintain good relationships with the contractors. He said the residents deserve to have this project finished.

Councilmember Riley shared that he is surprised that another extension proposal was not offered to meet in the middle to cover these costs.

Councilmember Olson said they want to have this project done without cutting corners, so he is supportive of moving forward for this reason.

The consensus of the Council was to move this to the Council meeting to be voted on.

2.02: Continued Review of Preliminary 2026 General Fund Budget/Levy

City Administrator Hagen continued the review of the preliminary 2026 general fund budget and levy.

Councilmember Riley stated he is resistant to most or all of the personnel requests as it would be a large amount in 2026, but would also build in an increase for next year and the years following. He said his ideal increase would be 7%.

Councilmember Specht said the positions that he would not be supportive of would be the Communications Specialist and the Recreation and Volunteer Assistant. He stated he would like the overall increase to be between 5% and 7%.

Councilmember Stewart shared that she does not like that the City is consistently getting closer to a 50% tax rate, as it is a very dangerous slope when it comes to tax dollars and home values. She

said she would like to see there be no increase this year; however, she knows that is not very realistic. She agreed with Councilmember Riley about not being supportive of adding any personnel. She said she would like to see the increase be as small as possible.

Councilmember Peters stated he would also like to see the increase be between 5% and 7%.

Councilmember Olson shared that they played a lot of catch-up last year, which caused a substantial increase, and this year's requests are riding that same wave. He noted he would like the increase to be between 5% and 7%.

Councilmember Buscher said she would like to see a single-digit increase. She noted that there are a lot of requests from departments that are not optional and need to be replaced. She stated they need to add the requested Fire and Police Department positions. She explained that she does not want residents to feel like they are being priced out of living in the City; however, she also wants to make sure they are providing the services that the residents need.

Councilmember Specht noted that some of the positions have alternate funding sources, which would not impact the budget directly.

Mayor Heineman shared that his personal property taxes have increased \$4,000 over the last six years that he has lived in Ramsey. He noted that, as much as he would love to move forward with all of these requests, they need to make some tough decisions to alleviate some of this impact on the residents. He said he would like to see the increase at or below 7.4%.

Councilmember Specht asked if there are any larger purchases that they want to issue certificates for.

City Administrator Hagen said this is always an option.

Finance Director Lund shared that the underwriting cost and levy would be an estimate of \$184,300 on \$1,467,000 bonded for over 10 years.

Councilmember Riley said if they cut everything from the budget that has already been outlined on the reductions list, then they would have already decreased the budget by almost \$750,000.

Finance Director Lund noted that if they removed requests like the Building Inspector role, then they would have to add the contracted services back to the budget, adding \$120,000 back into the budget.

City Administrator Hagen said that the City Engineer, Engineering Tech II, and Building Inspector positions are already largely offset, so they will likely stay in the revised budget when Staff brings this back to the Council.

Councilmember Specht asked if they would be able to put the amount that they are currently spending on contracted services with the request for the new position, so the Council can put things into perspective when they are looking at some of these requested roles.

Mayor Heineman said he would like to be respectful of the Staff's requests in the budget and would like the Staff to work to make cuts to the proposed budget to keep the increase minimal.

The consensus of the Council was to direct Staff to continue to work on the 2026 budget development based on Council discussion to keep the increase in the 5% to 7% range.

3. TOPICS FOR FUTURE DISCUSSION

3.01: Review Future Topics/ Calendar

Noted.

4. MAYOR / COUNCIL / STAFF INPUT

4.01: Update on Outside Committees

Councilmember Specht shared that new camera equipment was approved at the QCTV Committee meeting.

Councilmember Riley shared that he is excited that the City is adding a new position that will work with the Lower Rum River WMO to help handle open permits and cases.

Administrative Services Director Lasher shared an update on the Paid Family Medical Leave discussion around what would happen if the State makes a change to these requirements in the future, and they already have a contract with an outside vendor. She said they would not continue to be under contract with MetLife if the State were to change its requirements. She shared that the dental RFP came back, and the City costs will be decreasing by around \$5,000 annually with the new provider.

5. ADJOURNMENT

The Work Session of the City Council was adjourned at 6:32 p.m.

Respectfully submitted,

Brian S. Hagen
City Administrator

ATTEST:

Katie M. Schmidt
City Clerk

Drafted by Ava Major
TimeSaver Off Site Secretarial, Inc.

TABLE OF CONTENTS

1. CALL TO ORDER 2

2. APPROVE AGENDA 2

3. PRESENTATIONS..... 2

4. CITIZEN INPUT 2

5. CONSENT AGENDA 3

6. PUBLIC HEARING 3

7. COUNCIL BUSINESS..... 4

 7.01: Adopt Resolution #25-128 Approving Change Order No. 3 for Improvement Project #21-09, Centralized Water Treatment Plant 4

 7.02: Adopt Resolution #25-175 Approving Engineering Amendment No. 3 for Improvement Project #21-09, Centralized Water Treatment Plant 4

 7.03: Attorney-Client Privileged Discussion of Litigation: Murray v. City of Ramsey (Conciliation Court Appeal) - Closed to the Public..... 5

8. MAYOR, COUNCIL AND STAFF INPUT 5

9. ADJOURNMENT..... 5

**CITY COUNCIL
CITY OF RAMSEY
ANOKA COUNTY
STATE OF MINNESOTA**

The Ramsey City Council conducted a regular meeting on Tuesday, July 22, 2025, at the Ramsey Municipal Center, 7550 Sunwood Drive NW, Ramsey, Minnesota.

Members Present: Mayor Ryan Heineman
Councilmember Kirsten Buscher
Councilmember Michael Olson
Councilmember Eric Peters
Councilmember Chris Riley
Councilmember Dan Specht
Councilmember Shanna Stewart

Members Absent: None

Also Present: City Administrator Brian Hagen
City Engineer/Public Works Director Bruce Westby
City Attorney Fritz Knaak

1. CALL TO ORDER

Mayor Heineman called the regular meeting of the Ramsey City Council to order at 7:00 p.m., followed by the Pledge of Allegiance led by Mayor Heineman.

2. APPROVE AGENDA

Motion by Councilmember Olson, seconded by Councilmember Peters, to approve the agenda as presented.

Motion carried. Voting Yes: Mayor Heineman, Councilmembers Olson, Peters, Buscher, Riley, Specht, and Stewart. Voting No: None.

3. PRESENTATIONS

None.

4. CITIZEN INPUT

None.

5. CONSENT AGENDA

Motion by Councilmember Riley, seconded by Councilmember Specht, to approve the following items on the Consent Agenda:

- 5.01: Approve the Following Meeting Minutes:
 - 1) City Council Work Session dated July 8, 2025
 - 2) City Council Regular Session dated July 8, 2025
- 5.02: Approve Business License Applications
- 5.03: Adopt Resolution #25-174 Approving Cash Disbursements Made and Authorizing Payment of Accounts Payable Invoicing Received During the Period of July 3, 2025, through July 16, 2025.
- 5.04: Adopt Resolution #25-134 Approving Final Payment to Twin Cities Utilities LLC for Improvement Project #24-04, Ford Brook Estates Drainage Improvements.
- 5.05: Adopt Resolution #25-157, Approving a Development Agreement for Bunker Lake Crossing.
- 5.06: Adopt Resolution #25-158, Approving a Development Agreement for Chipotle at 14701 Armstrong Blvd NW.
- 5.07: Adopt Resolution #25-161 Approving Partial Payment to GMH Asphalt Corporation for IP #24-03, NE Ramsey Street Reconstructions.
- 5.08: Adopt Resolution #25-162 Approving Minnesota Laws, 2025 1st Special Session Chapter 13, Article 5, Section 2.
- 5.09: Adopt Resolution #25-163 Approving Partial Payment to North Valley, Inc. for Improvement Project #25-02, MSA Sunwood Drive Reconstruction.
- 5.10: Adopt Resolution #25-164 Approving Partial Payment to Douglas-Kerr Underground, LLC for Improvement Project #24-13, Fox Ridge Estates 1st & 2nd Street Reconstructions.
- 5.11: Adopt Resolution #25-166, Approving a Development Agreement for Kwik Trip at 8040 Bunker Lake Blvd NW.
- 5.12: Adopt Resolution #25-167 Approving Partial Payment to North Valley, Inc. for Improvement Project #25-05, High Point Street Reconstructions.
- 5.13: Adopt Resolution #25-168 Approving Partial Payment to Park Construction Company for Improvement Project #25-06, Sorteberg's Street Reconstruction.
- 5.14: Adopt Resolution #25-169 to North Valley, Inc. for Improvement Project #25-07, 2025 Neighborhood Pavement Overlay Improvements.
- 5.15: Adopt Resolution #25-170 Approving Final Payment to FlowSeal Surface Maintenance, Inc. for Improvement Project #25-09, 2025 Crack Seal Improvements.
- 5.16: Adopt Resolution #25-171 Approving Change Order #1 for Dickenson's Mississippi Estate Street Reconstructions, Improvement Project #25-04.
- 5.17: Adopt Resolution #25-172 Authorizing Partial Payment #25 to Magney Construction, Inc. for Improvement Project #21-09, Centralized Water Treatment Plant.

Motion carried. Voting Yes: Mayor Heineman, Councilmembers Riley, Specht, Buscher, Olson, Peters, and Stewart. Voting No: None.

6. PUBLIC HEARING

None.

7. COUNCIL BUSINESS

7.01: Adopt Resolution #25-128 Approving Change Order No. 3 for Improvement Project #21-09, Centralized Water Treatment Plant

City Engineer/Public Works Director Westby reviewed the Staff report in regard to the change order for the water treatment plant.

Mayor Heineman shared that the Council had a robust discussion on this topic during the Work Session.

Motion by Councilmember Peters, seconded by Councilmember Specht, to adopt Resolution #25-128 approving Change Order No. 3 for Improvement Project #21-09, Centralized Water Treatment Plant.

Further discussion:

Councilmember Riley said he will not be supporting this change order. He said he is supportive of the project getting finished, but not for the added time and costs that this change order brings.

Councilmember Specht noted that this was a \$31,000,000 project, and this change order is a very small percentage of the total cost, so he will be supporting this. He said things could have been done better on all sides, including the City. He stated he wants to get this project done and done well for the residents.

Councilmember Buscher stated she is looking forward to this project being completed and done well. She said they are understanding of the fact that not everything goes perfectly according to plan, especially with construction timelines. She noted that she is looking forward to this project being completed and being done well. She thanked the construction and engineering teams for participating in a robust discussion at the Work Session.

Councilmember Olson said he will be supporting this change order; however, not without hesitation. He noted that in the grand scheme of things, the right thing to do is to move forward with this.

Mayor Heineman added that he also will not be supporting this.

Motion carried. Voting Yes: Councilmembers Peters, Specht, Buscher, Olson, and Stewart.
Voting No: Mayor Heineman and Councilmember Riley.

7.02: Adopt Resolution #25-175 Approving Engineering Amendment No. 3 for Improvement Project #21-09, Centralized Water Treatment Plant

City Engineer/Public Works Director Westby reviewed the Staff report concerning the additional funding for the water treatment plant change order extension.

Motion by Councilmember Olson, seconded by Councilmember Peters, to adopt Resolution #25-175 approving the original Engineering Amendment No. 3 for Improvement Project #21-09, Centralized Water Treatment Plant.

Motion carried. Voting Yes: Councilmembers Olson, Peters, Buscher, and Specht. Voting No: Mayor Heineman, Councilmembers Riley and Stewart.

7.03: Attorney-Client Privileged Discussion of Litigation: Murray v. City of Ramsey (Conciliation Court Appeal) - Closed to the Public

City Administrator Hagen reviewed the Staff report in regard to the litigation of Murray versus the City of Ramsey. He called to move to Closed Session.

Motion by Councilmember Riley, seconded by Councilmember Olson, to recess to Closed Session at 7:13 p.m.

Motion carried. Voting Yes: Mayor Heineman, Councilmembers Riley, Olson, Buscher, Peters, Specht, and Stewart. Voting No: None.

The meeting reconvened to Open Session at 7:42 p.m.

City Administrator Hagen shared that the Council passed by consensus Resolution #25-177, which accepted and ratified the settlement terms in the matter of Karen Murray versus the City of Ramsey Police Department.

8. MAYOR, COUNCIL AND STAFF INPUT

City Administrator Hagen announced upcoming meetings and events. He shared that Highway 10 will be closed from 10:00 p.m. to 5:00 a.m. on July 23 to July 24 for construction.

Councilmember Peters shared that there is a park cleanup at Alpine Park at 6:30 p.m. tomorrow, July 23.

Councilmember Buscher shared that the Police Department will be playing their hockey game against the Anoka Police Department this Friday, July 25, at 5:30 p.m., and proceeds will be going to Shop with a Cop.

Councilmember Specht shared that the Party in the Park will be held on Thursday, July 31, at the Draw.

9. ADJOURNMENT

Motion by Councilmember Peters, seconded by Councilmember Olson, to adjourn the meeting.

Motion carried. Voting Yes: Mayor Heineman, Councilmembers Peters, Olson, Buscher, Riley, Specht, and Stewart. Voting No: None.

The regular meeting of the City Council adjourned at 7:45 p.m.

Respectfully submitted,

Brian S. Hagen
City Administrator

ATTEST:

Katie M. Schmidt
City Clerk

Drafted by Ava Major
TimeSaver Off Site Secretarial, Inc.

A recording of this meeting is available for viewing online at www.qctv.org
<<http://www.qctv.org>>. Recordings are available for 36 months after the date of the meeting.

**CITY COUNCIL CLOSED SESSION
CITY OF RAMSEY
ANOKA COUNTY
STATE OF MINNESOTA**

The Ramsey City Council conducted a Closed Session on Tuesday, July 22, 2025, at the Ramsey Municipal Center, 7550 Sunwood Drive NW, Ramsey, Minnesota.

Members Present: Mayor Ryan Heineman
Councilmember Kirsten Buscher
Councilmember Michael Olson
Councilmember Eric Peters
Councilmember Chris Riley
Councilmember Dan Specht
Councilmember Shanna Stewart

Also Present: City Administrator Brian Hagen
City Attorney Fritz Knaak

1. CALL TO ORDER

Mayor Heineman called the Closed Session of the City Council to order at 7:13 p.m.

2. COUNCIL BUSINESS

**2.02: Attorney-Client Privileged Discussion of Litigation: Murray v. City of Ramsey
(Conciliation Court Appeal) - Closed to the Public**

City Administrator Hagen reviewed the Staff report in regard to the litigation of Murray versus the City of Ramsey.

3. ADJOURNMENT

Motion by Councilmember Riley, seconded by Councilmember Peters, to adjourn the Closed Session.

Motion carried.

The Closed Session was adjourned at 7:42 p.m.

Respectfully submitted,

Brian S. Hagen
City Administrator

ATTEST:

Katie M. Schmidt
City Clerk

Drafted by Ava Rokosz
TimeSaver Off Site Secretarial, Inc.

CC Regular Session

Meeting Date: 08/12/2025

Primary Strategic Plan Initiative: Create a positive image for residential neighborhoods, business districts and key corridors.

Title

Approve Business License Applications

Purpose/Background:

The purpose of this case is to obtain City Council approval of business license applications (not including Rental or BRC).

Background: Certain businesses or groups in the City of Ramsey are required to apply for a business license in addition to the Business Registration Certificate (BRC). Other businesses that may require a license, but are not required to have a BRC, may also be included in this approval. Those new license requests and/or renewals are attached for City Council approval.

Notification:

All current business license holders are posted on www.cityoframsey.com once approved.

Funding Source:

License fees are collected at time of application.

Recommendation:

Staff recommends approval of business license applications.

OutcomeAction:

Motion to approve the attached business license applications.

Attachments

Business Licenses

Form Review

Inbox	Reviewed By	Date
Sean Sullivan	Sean Sullivan	08/07/2025 08:07 AM
Brian Hagen	Brian Hagen	08/07/2025 03:49 PM
Form Started By: Wendy Schlueter		Started On: 07/23/2025 04:25 PM
Final Approval Date: 08/07/2025		

Report Name: License Report - License Types

Council Dates: 8/12/2025 to 8/12/2025

Status: Active, Inactive

License Type(s): Mobile Food Unit-90 Days, Mobile Food Unit-Annual, Special Events, Therapeutic Massage Establishment, Therapeutic Massage Therapist, Transient Merchant/Peddler/Solicitor

City of Ramsey License Report - License Types

Printed: 8/6/2025

Page: 1

<u>Company</u>	<u>DBA</u>	<u>Complex Name</u>	<u>Applicant</u>	<u>Location</u>	<u>Exp. Date</u>	<u>Council Date</u>	<u>Status</u>
Mobile Food Unit-90 Days							
Sugar Sweet Mini Donuts		Sugar Sweet Mini Donuts	Travis Hoffman		11/30/2025	8/12/2025	A
Mobile Food Unit-Annual							
The Willy Wagon			Beverly Dahl		12/31/2025	8/12/2025	A
Transient Merchant/Peddler/Solicitor							
EcoShield Pest Solutions			Nicholas Everett Norton		12/31/2025	8/12/2025	A
Curbside Waste Inc		Jared Haymore (Solicitor)	Chad Lewis Master		12/31/2025	8/12/2025	A
Sunburn Construction	Everlight Solar	Kazmine Langness	(Multiple)		12/31/2025	8/12/2025	A
Sunburn Construction	Everlight Solar	Ramaero Breitholtz	(Multiple)		12/31/2025	8/12/2025	A

Mobile Food Unit-90 Days License Count: 1

Mobile Food Unit-Annual License Count: 1

Transient Merchant/Peddler/Solicitor License Count: 4

Total Licenses: 6

CC Regular Session

Meeting Date: 08/12/2025

Primary Strategic Plan Initiative: Not Applicable

Title:

Approve Request to Declare Surplus Property

Purpose/Background:

Staff is requesting Council declare the following property surplus and authorize the disposal/sale of same:

- Six (6) iPhones
- One (1) Samsung Galaxy S20

Recommendation:

Motion to declare the items listed as surplus, authorizing staff to dispose of/sell items as needed.

Outcome/Action:

Motion to declare the items listed as surplus, authorizing staff to dispose of/sell items as needed.

Attachments

No file(s) attached.

Form Review

Inbox	Reviewed By	Date
Diana Lund	Diana Lund	08/04/2025 08:41 AM
Brian Hagen	Brian Hagen	08/07/2025 03:49 PM
Form Started By: Jason Fredrickson		Started On: 07/30/2025 09:27 AM
Final Approval Date: 08/07/2025		

CC Regular Session

Meeting Date: 08/12/2025

Primary Strategic Plan Initiative:

Title:

Adopt Resolution #25-182 Approving Cash Disbursements Made and Authorizing Payment of Accounts Payable Invoicing Received During the Period of July 17, 2025 through August 6, 2025.

Purpose/Background:

Adopt Resolution #25-182 Approving Cash Disbursements Made and Authorizing Payment of Accounts Payable Invoicing Received During the Period of July 17, 2025 through August 6, 2025.

Recommendation:

Staff Recommends to Adopt Resolution #25-182 Approving Cash Disbursements Made and Authorizing Payment of Accounts Payable Invoicing Received During the Period of July 17, 2025 through August 6, 2025.

Outcome/Action:

Motion to Adopt Resolution #25-182 Approving Cash Disbursements Made and Authorizing Payment of Accounts Payable Invoicing Received During the Period of July 17, 2025 through August 6, 2025.

Attachments

Bills List 08/12/2025
Resolution 25-182

Form Review

Inbox	Reviewed By	Date
Diana Lund	Diana Lund	08/07/2025 06:54 AM
Brian Hagen	Brian Hagen	08/07/2025 03:50 PM
Form Started By: Jennifer Morrison		Started On: 08/06/2025 01:58 PM
Final Approval Date: 08/07/2025		

RAMSEY CITY COUNCIL MEETING
8.12.2025
BILLS LIST

DISBURSEMENTS TO BE APPROVED THIS MEETING:

DISBURSEMENT TYPE:	SUBMITTED FOR APPROVAL
Prepays 7.17.25 - 8.6.25	\$ 908,090.35
Accounts Payable 7.17.25 - 8.6.25	504,460.06
Payroll 7.18.25	312,465.35
8.1.25	287,827.63
Debt Service	
Pay Estimates- Projects	

TOTAL SUBMITTED FOR APPROVAL THIS MEETING
(Invoices Available for Reviewal)

\$ 2,012,843.39

DISBURSEMENTS PREVIOUSLY APPROVED AND PAID:

	APPROVED PREVIOUS MTG	2025 Y.T.D.
PREPAIDS	\$ 494,796.15	\$ 6,634,643.97
PREPAID ADJUSTMENTS		
ACCOUNTS PAYABLE INVOICING	557,671.36	8,819,200.45
ACCT PAYABLE INVOICING ADJUSTMENTS		
NET PAYROLL TOTAL	286,479.28	4,034,694.96
CORRECTION TO PAYROLL		
DEBT SERVICE		639,325.63
CORRECTION TO DEBT SERVICE		
PAY ESTIMATE(S) - PROJECTS	2,447,744.58	10,499,300.00

TOTAL CASH DISBURSEMENTS PREVIOUSLY APPROVED

\$ 3,786,691.37

\$ 30,627,165.01

THIS PAGE LEFT BLANK INTENTIONALLY

Council Check Register by GL
Council Check Register and Summary

7/17/2025 - 8/6/2025

Check #	Date	Amount	Supplier / Explanation	PO #	Doc No	Inv No	Account No	Subledger	Account Description	Business Unit
121147	7/24/2025		121046 19 SPORTS						Continued...	
		1,140.00	SPORTS DISCOVERY PROGRAMS		132789	219	0452.6489		OTHER CONTRACTED SERVICES	PARK & RECREATION
		<u>1,140.00</u>								
121148	7/24/2025		117451 INKY ELF LLC							
		26.50	ADOPT-A-SPOT		132790	13928	0452.6249		MISCELLANEOUS OPERATING SUPPLY	PARK & RECREATION
		<u>26.50</u>								
121149	7/24/2025		121621 JONAH AND THE WHALES							
		2,125.00	7.24 CONCERT FINAL PYMT		132779	7/24 CONCERT	9270.6315		MISCELLANEOUS PROFESSIONAL SER	LAWFUL GAMBLING
						FINAL PYMT				
		<u>2,125.00</u>								
121150	7/24/2025		120695 MURRAY, KAREN							
		2,500.00	RESOLUTION 25-177		132780	25-177	9702.6461		AWARDS & INDEMNITIES	SELF INSURANCE
		0.00	MN DIST CT FILE 02-CV-24-6078		132780	25-177	9702.6461		AWARDS & INDEMNITIES	SELF INSURANCE
		<u>2,500.00</u>								
121151	7/24/2025		119555 RM GOLF CARTS INC							
		540.00			132797	6120	9230.6249	00923002	MISCELLANEOUS OPERATING SUPPLY	ECONOMIC DEVELOPMENT AUTHO
		<u>540.00</u>								
121152	7/31/2025		117700 A HARD DAYS NIGHT TRIBUTE							
		2,125.00	7.31 CONCERT SERIES FINAL PYMT		132890	7.31 CONCERT	9270.6315		MISCELLANEOUS PROFESSIONAL SER	LAWFUL GAMBLING
						FINAL PYMT				
		<u>2,125.00</u>								
121153	7/31/2025		121652 BAGSTAD, CHERI							
		200.00	WATER EFF REBATE 25-C BAGSTAD		132904	072925	9601.6436		WATER EFFICIENCY REBATE PROG	WATER FUND
		<u>200.00</u>								
121154	7/31/2025		100297 CENTERPOINT ENERGY							
		95.24	JUNE 2025 GAS CHARGES		132911	8000014064-2	0211.6373		GAS	POLICE PROTECTION
						JUN 2025				
		123.08	JUNE 2025 GAS CHARGES		132911	8000014064-2	0452.6373		GAS	PARK & RECREATION
						JUN 2025				
		39.94	JUNE 2025 GAS CHARGES		132911	8000014064-2	0311.6373		GAS	STREET MAINTENANCE
						JUN 2025				
		43.69	JUNE 2025 GAS CHARGES		132911	8000014064-2	0220.6373		GAS	FIRE PROTECTION
						JUN 2025				
		39.95	JUNE 2025 GAS CHARGES		132911	8000014064-2	9601.6373		GAS	WATER FUND

CITY OF RAMSEY
 Council Check Register by GL
 Council Check Register and Summary

7/17/2025 -- 8/6/2025

Check #	Date	Amount	Supplier / Explanation	PO #	Doc No	Inv No	Account No	Subledger	Account Description	Business Unit
121154	7/31/2025		100297 CENTERPOINT ENERGY						Continued...	
		39.95	JUNE 2025 GAS CHARGES		132911	8000014064-2	9602.6373		GAS	SEWER FUND
		39.94	JUNE 2025 GAS CHARGES		132911	8000014064-2	9605.6373		GAS	STORM WATER UTILITY
		421.79								
121155	7/31/2025		121970 CENTRAL PRO SUPPLY							
		410.44	IRRIGATION SUPPLIES		132895	66002674-00	0452.6268		IRRIGATION SUPPLIES	PARK & RECREATION
		410.44								
121156	7/31/2025		100116 CONNEXUS ENERGY							
		700.01	JUNE 2025 ELMCREST PARK		132896	444931-267449	0452.6371		ELECTRIC UTILITIES	PARK & RECREATION
		20.69	7040 173RD AVE/JUNE 2025		132898	444931-3270	0452.6371		ELECTRIC UTILITIES	PARK & RECREATION
		91.80	JUL 2025 SIREN UTILITIES		132899	759126-303095	0250.6371		ELECTRIC UTILITIES	CIVIL DEFENSE
		10,792.90	06/18-7/17/25 ELECTRIC USE		132900	759126-303101	9603.6371		ELECTRIC UTILITIES	STREET LIGHTING FUND
		16,627.84	06/18-7/17/25 ELECTRIC USE		132901	759126-303107	0194.6371		ELECTRIC UTILITIES	GENERAL GOVERNMENT BUILDING
		1,122.86	06/18-7/17/25 ELECTRIC USE		132901	759126-303107	0220.6371		ELECTRIC UTILITIES	FIRE PROTECTION
		65.82	06/18-7/17/25 ELECTRIC USE		132901	759126-303107	9230.6249		MISCELLANEOUS OPERATING SUPPLY	ECONOMIC DEVELOPMENT AUTHO
		3,152.87	06/18-7/17/25 ELECTRIC USE		132901	759126-303107	9240.6371		ELECTRIC UTILITIES	PARKING RAMP MAINTENANCE
		30.10	06/18-7/17/25 ELECTRIC USE		132901	759126-303107	9410.6371	00041018	ELECTRIC UTILITIES	RALF FUNDED PROJECTS
		837.56	06/18-7/17/25 ELECTRIC USE		132901	759126-303107	9410.6371	00041012	ELECTRIC UTILITIES	RALF FUNDED PROJECTS
		17,714.97	JULY 2025 ELECTRICITY		132902	759126-303102	9601.6371		ELECTRIC UTILITIES	WATER FUND
		4,319.12	JULY 2025 ELECTRICITY		132902	759126-303102	9602.6371		ELECTRIC UTILITIES	SEWER FUND
		356.54	JULY 2025 ELECTRICITY		132902	759126-303102	9605.6371		ELECTRIC UTILITIES	STORM WATER UTILITY
		3,294.80	JULY 2025 ELECTRIC		132908	759126-303106	0452.6371		ELECTRIC UTILITIES	PARK & RECREATION

Council Check Register by GL
Council Check Register and Summary

7/17/2025 - 8/6/2025

Check #	Date	Amount	Supplier / Explanation	PO #	Doc No	Inv No	Account No	Subledger	Account Description	Business Unit
121162	7/31/2025		113539 WINSUPPLY TWIN CITIES MN CO.						Continued...	
		30-	EARLY PAY DISCOUNT		132906	170284 01	0194.6259		BUILDING MAINT/REPAIR SUPPLIES	GENERAL GOVERNMENT BUILDING
		15.10	MISC BLDG REPAIR SUPPLIES		132906	170284 01	0194.6259		BUILDING MAINT/REPAIR SUPPLIES	GENERAL GOVERNMENT BUILDING
		978.37	MISC BLDG REPAIR SUPPLIES		132907	170099 01	0194.6259		BUILDING MAINT/REPAIR SUPPLIES	GENERAL GOVERNMENT BUILDING
		19.57-	EARLY PAY DISCOUNT		132907	170099 01	0194.6259		BUILDING MAINT/REPAIR SUPPLIES	GENERAL GOVERNMENT BUILDING
		<u>973.60</u>								
1008268	7/18/2025		119638 O'REILLY AUTO PARTS							
		5.43-	EARLY PAY DISCOUNT		132737	6193-210387	0311.6257		OTHER VEHICLE PARTS	STREET MAINTENANCE
		315.58	TORO GROUND MASTER #617		132737	6193-210387	0311.6257		OTHER VEHICLE PARTS	STREET MAINTENANCE
		1.27-	EARLY PAY DISCOUNT		132738	6193-210543	0311.6257		OTHER VEHICLE PARTS	STREET MAINTENANCE
		63.71	BUILDING TRK. #410		132738	6193-210543	0311.6257		OTHER VEHICLE PARTS	STREET MAINTENANCE
		.60-	EARLY PAY DISCOUNT		132739	6193-210622	0452.6229		SHOP MATERIALS	PARK & RECREATION
		29.99	PORTABLE PRESSURE WASHER		132739	6193-210622	0452.6229		SHOP MATERIALS	PARK & RECREATION
		1.64-	EARLY PAY DISCOUNT		132740	6193-210737	0452.6257		OTHER VEHICLE PARTS	PARK & RECREATION
		1.63-	EARLY PAY DISCOUNT		132740	6193-210737	0311.6257		OTHER VEHICLE PARTS	STREET MAINTENANCE
		81.79	TAURUS #405		132740	6193-210737	0311.6257		OTHER VEHICLE PARTS	STREET MAINTENANCE
		81.79	TAURUS #405		132740	6193-210737	0452.6257		OTHER VEHICLE PARTS	PARK & RECREATION
		.36-	EARLY PAY DISCOUNT		132741	6193-210740	0311.6257		OTHER VEHICLE PARTS	STREET MAINTENANCE
		18.03	POLICE #301		132741	6193-210740	0311.6257		OTHER VEHICLE PARTS	STREET MAINTENANCE
		44.00-	2 CORE RETURNS		132742	6193-210406	0311.6257		OTHER VEHICLE PARTS	STREET MAINTENANCE
		1.77-	EARLY PAY DISCOUNT		132743	6193-210533	0311.6257		OTHER VEHICLE PARTS	STREET MAINTENANCE
		88.34	PARKS TRK. #665		132743	6193-210533	0311.6257		OTHER VEHICLE PARTS	STREET MAINTENANCE
		<u>622.53</u>								
1008269	7/22/2025		100257 LAW ENFORCEMENT LABOR SRV INC							
		985.50			132399	0701251404292	9101.2177		UNION DUES	GENERAL FUND
		985.50			132694	071625928182	9101.2177		UNION DUES	GENERAL FUND
		<u>1,971.00</u>								
1008270	7/22/2025		100298 MN AFSCME COUNCIL 5							
		612.20			132400	0701251404293	9101.2177		UNION DUES	GENERAL FUND
		612.20			132695	071625928183	9101.2177		UNION DUES	GENERAL FUND
		<u>1,224.40</u>								
1008325	7/25/2025		100011 ACE SALES							
		158.50	BIZ OF YR AWARD		132793	2078	9230.6249	00923002	MISCELLANEOUS OPERATING SUPPLY ECONOMIC DEVELOPMENT AUTHO	
		<u>158.50</u>								
1008326	7/25/2025		110402 ADVANCE AUTO PARTS							
		473.94	JUNE 2025 MONTHLY PURCHASES		132777	JUNE 2025	0311.6257		OTHER VEHICLE PARTS	STREET MAINTENANCE

Council Check Register by GL
Council Check Register and Summary

7/17/2025 - 8/6/2025

Check #	Date	Amount	Supplier / Explanation	PO #	Doc No	Inv No	Account No	Subledger	Account Description	Business Unit
1008326	7/25/2025		110402 ADVANCE AUTO PARTS						Continued...	
		473.94							PURCHASES	
1008327	7/25/2025		117439 ENGLAND, JORDAN							
		15.46	7.15.25 JIMMY JOHNS		132778	07152025	0211.6331		TRAVEL & LODGING	POLICE PROTECTION
		15.92	7.16.25 DAVANNIS		132778	07152025	0211.6331		TRAVEL & LODGING	POLICE PROTECTION
		31.38								
1008328	7/25/2025		112564 GROUP HEALTH INC WORKSITE							
		247.20	EAP SERVICES - JULY 2025		132784	7113044	0130.6315		MISCELLANEOUS PROFESSIONAL SERADMINISTRATION	
		247.20								
1008329	7/25/2025		121552 LINCOLN NATIONAL LIFE INSURANCE CO							
		2,640.50	JULY 2025 LIFE INS PREMIUMS		132792	1094824 JULY 2025	9101.2176		LIFE/HEALTH-EMPLOYEE	GENERAL FUND
		2,640.50								
1008330	7/25/2025		100291 MET COUNCIL SAC							
		86,975.00	SAC REMITTANCE		132781	JUNE 2025	9602.2083		SAC CHARGES	SEWER FUND
		869.75	SAC REMITTANCE DISCOUNT		132781	JUNE 2025	9602.4356		SEWER AVAILABILITY CHARGE-ADM	SEWER FUND
		86,105.25								
1008331	7/25/2025		119638 O'REILLY AUTO PARTS							
		1.12	EARLY PAY DISCOUNT		132799	6193-211515	0311.6257		OTHER VEHICLE PARTS	STREET MAINTENANCE
		55.96	STREETS TRK. #692		132799	6193-211515	0311.6257		OTHER VEHICLE PARTS	STREET MAINTENANCE
		.78	EARLY PAY DISCOUNT		132800	6193-211236	0311.6257		OTHER VEHICLE PARTS	STREET MAINTENANCE
		38.94	POLICE #311		132800	6193-211236	0311.6257		OTHER VEHICLE PARTS	STREET MAINTENANCE
		93.00								
1008332	7/25/2025		114486 SUN LIFE ASSURANCE COMPANY OF CANADA							
		477.14	JULY 2025 NON-VOL LTD PREMIUMS		132791	237724 JULY 2025	9101.2170		DENTAL/DISABILITY/LIFE	GENERAL FUND
		1,015.34	JULY 2025 VOL LTD PREMIUMS		132791	237724 JULY 2025	9101.2170		DENTAL/DISABILITY/LIFE	GENERAL FUND
		1,492.48								
1008333	7/25/2025		100510 VERIZON WIRELESS							
		40.04	IPADS FOR FIRE INSPECTIONS		132786	6118115915 JUN 2025	0220.6249		MISCELLANEOUS OPERATING SUPPLYFIRE PROTECTION	
		5,565.00	STAFF CELL PHONES		132786	6118115915 JUN 2025	0192.6323		CELLULAR PHONES	DATA PROCESSING

CITY OF RAMSEY
 Council Check Register by GL
 Council Check Register and Summary

7/17/2025 - 8/6/2025

Check #	Date	Amount	Supplier / Explanation	PO #	Doc No	Inv No	Account No	Subledger	Account Description	Business Unit
1008333	7/25/2025		100510 VERIZON WIRELESS						Continued...	
		20.02	RAMP ELEVATOR		132786	6118115915 JUN	9240.6321		TELEPHONE	PARKING RAMP MAINTENANCE
						2025				
		5,625.06				2025				
1008334	8/1/2025		114432 HESSE, BRADLEY							
		19.42	7.21.25 TONOS		132892	072125-072325	0211.6331		TRAVEL & LODGING	POLICE PROTECTION
		18.30	7.22.25 PIZZA RANCH		132892	072125-072325	0211.6331		TRAVEL & LODGING	POLICE PROTECTION
		20.00	7.23.25 FIVE GUYS		132892	072125-072325	0211.6331		TRAVEL & LODGING	POLICE PROTECTION
		57.72								
1008335	8/1/2025		119638 O'REILLY AUTO PARTS							
		.11-	EARLY PAY DISCOUNT		132905	6193-213128	0211.6257		OTHER VEHICLE PARTS	POLICE PROTECTION
		5.49	CONNECTOR - SAFETY CAMP TRAILER		132905	6193-213128	0211.6257		OTHER VEHICLE PARTS	POLICE PROTECTION
		2.70-	EARLY PAY DISCOUNT		132910	6193-212628	0311.6257		OTHER VEHICLE PARTS	STREET MAINTENANCE
		134.99	STAFF #303		132910	6193-212628	0311.6257		OTHER VEHICLE PARTS	STREET MAINTENANCE
		137.67								
94071825	7/18/2025		122049 VOYA INSTITUTIONAL TRUST COMPANY							
		6,826.76			132693	0716259281816	9101.2176		LIFE/HEALTH-EMPLOYEE	GENERAL FUND
		6,826.76								
95071825	7/18/2025		122049 VOYA INSTITUTIONAL TRUST COMPANY							
		14,880.84			132692	0716259281815	9101.2175		DEFERRED COMPENSATION	GENERAL FUND
		14,880.84								
95080125	8/1/2025		122049 VOYA INSTITUTIONAL TRUST COMPANY							
		6,883.88			132870	07302510510016	9101.2176		LIFE/HEALTH-EMPLOYEE	GENERAL FUND
		6,883.88								
96071825	7/18/2025		118579 ND CHILD SUPPORT DIVISION							
		287.08			132691	0716259281814	9101.2185		GARNISHMENTS/SUPPORT	GENERAL FUND
		287.08								
96080125	8/1/2025		122049 VOYA INSTITUTIONAL TRUST COMPANY							
		15,180.84			132869	07302510510015	9101.2175		DEFERRED COMPENSATION	GENERAL FUND
		15,180.84								
97071825	7/18/2025		115568 ALERUS FINANCIAL NA							
		10,868.10			132690	0716259281813	9101.2176		LIFE/HEALTH-EMPLOYEE	GENERAL FUND

Council Check Register by GL
Council Check Register and Summary

7/17/2025 -- 8/6/2025

Check #	Date	Amount	Supplier / Explanation	PO #	Doc No	Inv No	Account No	Subledger	Account Description	Business Unit
97071825	7/18/2025	10,868.10	115568 ALERUS FINANCIAL NA						Continued...	
97080125	8/1/2025	287.08	118579 ND CHILD SUPPORT DIVISION		132868	07302510510014	9101.2185		GARNISHMENTS/SUPPORT	GENERAL FUND
		287.08								
98071825	7/18/2025	470.00	107962 TOTAL ADMINISTRATIVE SERV (DO NOT USE)		132689	0716259281812	9101.2176		LIFE/HEALTH-EMPLOYEE	GENERAL FUND
		470.00								
98080125	8/1/2025	10,964.77	115568 ALERUS FINANCIAL NA		132867	07302510510013	9101.2176		LIFE/HEALTH-EMPLOYEE	GENERAL FUND
		10,964.77								
99071825	7/18/2025	129.94	100219 HOME DEPOT COMMERCIAL ACCT PROGRAM		132732	JULY 2025	0220.6335		TRAINING	FIRE PROTECTION
			7.1.25 WALL FLOOD LIGHT							
		2.60-	EARLY PAY DISCOUNT		132732	JULY 2025	0220.6335		TRAINING	FIRE PROTECTION
		127.34								
99080125	8/1/2025	470.00	107962 TOTAL ADMINISTRATIVE SERV (DO NOT USE)		132866	07302510510012	9101.2176		LIFE/HEALTH-EMPLOYEE	GENERAL FUND
		470.00								
99129312	8/1/2025	18,871.53	100601 MN DEPT OF REV WH		132877	0730251051008	9101.2172		STATE WITHHOLDING	GENERAL FUND
		18,871.53								
99199534	8/1/2025	1,916.54	100223 ICMA RETIREMENT TRUST 457		132863	0730251051001	9101.2175		DEFERRED COMPENSATION	GENERAL FUND
		1,916.54								
99250290	7/18/2025	16.00	100301 MN CHILD SUPPORT PAYMENT CNTR		132590	0714251151221	9101.2185		GARNISHMENTS/SUPPORT	GENERAL FUND
		278.26			132696	071625928184	9101.2185		GARNISHMENTS/SUPPORT	GENERAL FUND
		543.14			132697	071625928185	9101.2185		GARNISHMENTS/SUPPORT	GENERAL FUND
		837.40								
99250336	8/1/2025		100301 MN CHILD SUPPORT PAYMENT CNTR							

Council Check Register by GL
Council Check Register and Summary

7/17/2025 - 8/6/2025

Check #	Date	Amount	Supplier / Explanation	PO #	Doc No	Inv No	Account No	Subledger	Account Description	Business Unit
99250336	8/1/2025		100301 MN CHILD SUPPORT PAYMENT CNTR						Continued...	
		278.26			132873	0730251051004	9101.2185		GARNISHMENTS/SUPPORT	GENERAL FUND
		543.14			132874	0730251051005	9101.2185		GARNISHMENTS/SUPPORT	GENERAL FUND
		<u>821.40</u>								
99511199	7/18/2025		100223 ICMA RETIREMENT TRUST 457							
		1,916.54			132686	071625928181	9101.2175		DEFERRED COMPENSATION	GENERAL FUND
		<u>1,916.54</u>								
99734538	7/18/2025		101306 IRS							
		414.09			132543	0711251144282	9101.2171		FEDERAL WITHHOLDING	GENERAL FUND
		2,121.23			132544	0711251144283	9101.2173		FICA & MEDICARE-EMPLOYEE	GENERAL FUND
		2,121.23			132545	0711251144284	9101.2182		FICA & MEDICARE-EMPLOYER	GENERAL FUND
		300.00			132594	0714251151225	9101.2171		FEDERAL WITHHOLDING	GENERAL FUND
		298.47			132595	0714251151226	9101.2173		FICA & MEDICARE-EMPLOYEE	GENERAL FUND
		298.47			132596	0714251151227	9101.2182		FICA & MEDICARE-EMPLOYER	GENERAL FUND
		23,730.26			132687	0716259281810	9101.2173		FICA & MEDICARE-EMPLOYEE	GENERAL FUND
		23,730.26			132688	0716259281811	9101.2182		FICA & MEDICARE-EMPLOYER	GENERAL FUND
		38,943.68			132701	071625928189	9101.2171		FEDERAL WITHHOLDING	GENERAL FUND
		<u>91,957.69</u>								
99762528	7/18/2025		100601 MN DEPT OF REV WH							
		443.30			132542	0711251144281	9101.2172		STATE WITHHOLDING	GENERAL FUND
		50.00			132593	0714251151224	9101.2172		STATE WITHHOLDING	GENERAL FUND
		18,508.42			132700	071625928188	9101.2172		STATE WITHHOLDING	GENERAL FUND
		<u>19,001.72</u>								
99808750	7/18/2025		100398 PUBLIC EMPLOYEES RETIREMENT ASSN							
		75.00			132591	0714251151222	9101.2174		PERA-EMPLOYEE	GENERAL FUND
		75.00			132592	0714251151223	9101.2183		PERA-EMPLOYER	GENERAL FUND
		35,213.31			132698	071625928186	9101.2174		PERA-EMPLOYEE	GENERAL FUND
		46,599.40			132699	071625928187	9101.2183		PERA-EMPLOYER	GENERAL FUND
		<u>81,962.71</u>								
99810538	8/1/2025		100398 PUBLIC EMPLOYEES RETIREMENT ASSN							
		35,680.18			132875	0730251051006	9101.2174		PERA-EMPLOYEE	GENERAL FUND
		47,208.37			132876	0730251051007	9101.2183		PERA-EMPLOYER	GENERAL FUND
		<u>82,888.55</u>								
99914997	8/1/2025		101306 IRS							
		24,053.50			132864	07302510510010	9101.2173		FICA & MEDICARE-EMPLOYEE	GENERAL FUND

Council Check Register by GL
Council Check Register and Summary

7/17/2025 -- 8/6/2025

<u>Check #</u>	<u>Date</u>	<u>Amount</u>	<u>Supplier / Explanation</u>	<u>PO #</u>	<u>Doc No</u>	<u>Inv No</u>	<u>Account No</u>	<u>Subledger</u>	<u>Account Description</u>	<u>Business Unit</u>
99914997	8/1/2025		101306 IRS						Continued...	
		24,053.50			132865	07302510510011	9101.2182		FICA & MEDICARE-EMPLOYER	GENERAL FUND
		39,809.09			132878	0730251051009	9101.2171		FEDERAL WITHHOLDING	GENERAL FUND
		87,916.09								
		<u>906,444.35</u>	Grand Total							

Payment Instrument Totals

Checks	350,226.86
EFT Payments	455,336.86
A/P ACH Payment	<u>100,880.63 + 1,646</u> (pd on 7.16.25) see next page
Total Payments	908,090.35

Council Check Register by GL
Council Check Register and Summary

7/16/2025 -- 8/6/2025

Check #	Date	Amount	Supplier / Explanation	PO #	Doc No	Inv No	Account No	Subledger	Account Description	Business Unit
99071625	7/16/2025		100629 MN DEPT OF REV SALES TX							
		569.21	JUNE 2025 SALES/TRANS/USE TAX		132744	07162025	9101.4305		RENTAL FEES	GENERAL FUND
		12.70	JUNE 2025 SALES/TRANS/USE TAX		132744	07162025	9101.4328		ACCIDENT REPORTS	GENERAL FUND
		1.33	JUNE 2025 SALES/TRANS/USE TAX		132744	07162025	9101.4609		OTHER MISCELLANEOUS REVENUES	GENERAL FUND
		1,062.52	JUNE 2025 SALES/TRANS/USE TAX		132744	07162025	9601.2082		SALES/USE TAX PAYABLE	WATER FUND
		.05	JUNE 2025 SALES/TRANS/USE TAX		132744	07162025	9601.2085		ANOKA COUNTY TRANSIT TAX .25%	WATER FUND
		.05	JUNE 2025 SALES/TRANS/USE TAX		132744	07162025	9601.2086		METRO TAX HOUSING .25%	WATER FUND
		.14	JUNE 2025 SALES/TRANS/USE TAX		132744	07162025	9601.2087		METRO TAX TRANSPORTATION .75%	WATER FUND
		<u>1,646.00</u>								

1,646.00 Grand Total

Payment Instrument Totals

Checks	
EFT Payments	1,646.00
Total Payments	<u>1,646.00</u>

This didn't get added to the bills list for the 7.22 city council meeting. I received the paperwork on 7.18.25 but was told the payment was made on 7.16.25. I am adding this to the bills list for the council meeting on 8.12.25.
JM

Payment Group Control Number 4041
 Bank Account 999.1010 CASH IN BANK 00002224
 Version LOGIS004V
 Originator JMORRISON
 Payment Instrument Check Payment
 Pay Through Date 8/13/2025

Payee		Stub	Document				Due	Invoice	Payment	Discount	Supplier	
Number	Name / Mailing Address	Message	Ty	Number	Itm	Co	Date	Number	Amount	Taken	Number	Name
113185	3-WAY ELECTRIC INC		PV	132931	001	00999	7/17/2025	24172	1,400.00		113185	3-WAY ELECTRIC INC
	3-WAY ELECTRIC INC								Summary Total	1,400.00		
	19949 ST FRANCIS BLVD								Payment Amount	1,400.00		
	ANOKA MN 55303											
122112	ALAN ANDERSON LAW FIRM LLC	Inv #00001-13	PV	132840	001	00999	7/18/2025	00001-13	400.00		122112	ALAN ANDERSON LAW FIRM LLC
	ALAN ANDERSON LAW FIRM LLC								Summary Total	400.00		
	11100 WAYZATA BLVD STE 545								Payment Amount	400.00		
	MINNEAPOLIS MN 55305											
107776	ALERT ALL CORP		PV	133019	001	00999	7/25/2025	W51188	951.00		107776	ALERT ALL CORP
	ALERT ALL CORP								Summary Total	951.00		
	164 ORLAN ROAD								Payment Amount	951.00		
	NEW HOLLAND PA 17557											
119568	ALLISON'S PETITE PASTRIES		PV	132961	001	00999	7/28/2025	2	406.57		119568	ALLISON'S PETITE PASTRIES
	ALLISON'S PETITE PASTRIES								Summary Total	406.57		
	14037 ST FRANCIS BOULEVARD NW								Payment Amount	406.57		
	RAMSEY MN 55303											
100058	ANOKA RAMSEY FARM AND		PV	132999	001	00999	8/1/2025	08012025	210.00		100058	ANOKA RAMSEY FARM

CITY OF RAMSEY
Create Payment Control Groups

Payment Group Control Number 4041
 Bank Account 999.1010 CASH IN BANK 00002224
 Version LOGIS004V
 Originator JMORRISON
 Payment Instrument Check Payment
 Pay Through Date 8/13/2025

Payee		Stub	Document			Due	Invoice	Payment	Discount	Supplier		
Number	Name / Mailing Address	Message	Ty	Number	Itm	Co	Date	Number	Amount	Taken	Number	Name
	GARDEN											AND GARDEN
	ANOKA RAMSEY FARM AND GARDEN			Summary Total					210.00			
	7435 HIGHWAY 10		PV	133001	001	00999	7/30/2025	07302025	67.96			
	RAMSEY MN 55303			Summary Total					67.96			
			PV	133026	001	00999	7/31/2025	07312025	115.53			
				Summary Total					115.53			
				Payment Amount					393.49			
100063	ASPEN MILLS		PV	132811	001	00999	7/17/2025	357657	477.75			100063 ASPEN MILLS
	ASPEN MILLS			Summary Total					477.75			
	8201 C CENTRAL AVE NE		PV	132946	001	00999	7/24/2025	358022	1,777.31			
	SPRING LAKE PARK MN 55432			Summary Total					1,777.31			
			PV	133018	001	00999	7/30/2025	358342	339.19			
				Summary Total					339.19			
			PV	133020	001	00999	7/31/2025	358487	326.34			
				Summary Total					326.34			
			PV	133021	001	00999	7/31/2025	358486	259.20			
				Summary Total					259.20			
			PV	133022	001	00999	7/31/2025	358484	339.19			
				Summary Total					339.19			
			PV	133023	001	00999	7/31/2025	358485	339.19			
				Summary Total					339.19			
				Payment Amount					3,858.17			
122119	BILDEAUX SERVICES		PV	132972	001	00999	7/25/2025	7232025	700.00			122119 BILDEAUX SERVICES

Payment Group Control Number 4041
 Bank Account 999.1010 CASH IN BANK 00002224
 Version LOGIS004V
 Originator JMORRISON
 Payment Instrument Check Payment
 Pay Through Date 8/13/2025

Payee		Stub	Document				Due	Invoice	Payment	Discount	Supplier	
Number	Name / Mailing Address	Message	Ty	Number	Itm	Co	Date	Number	Amount	Taken	Number	Name
	BILDEAUX SERVICES 21473 MANNING TRAIL SCANDIA MN 55073			Summary Total					700.00			
				Payment Amount					700.00			
108513	BLAINE LOCK AND SAFE INC		PV	133004	001	00999	7/28/2025	33500	816.00		108513	BLAINE LOCK AND SAFE INC
	BLAINE LOCK AND SAFE INC 10136 SUNSET AVENUE BLAINE MN 55014			Summary Total					816.00			
				Payment Amount					816.00			
114529	BRUCE JACOBSON LANDSCAPE ARCHITECT		PV	132761	001	00999	7/10/2025	7102025	1,000.00		114529	BRUCE JACOBSON LANDSCAPE ARCHITECT
	BRUCE JACOBSON LANDSCAPE ARCHITECT 4204 PILLSBURY AVENUE S MINNEAPOLIS MN 55409			Summary Total					1,000.00			
				Payment Amount					1,000.00			
121970	CENTRAL PRO SUPPLY		PV	132844	001	00999	7/22/2025	66002910-00	100.72		121970	CENTRAL PRO SUPPLY
	CENTRAL PRO SUPPLY 8 WILLIAMS STREET ELMSFORD NY 10523			Summary Total					100.72			
				Payment Amount					100.72			
117573	CHRAVE DAVIS PAINTING		PV	132775	001	00999	7/7/2025	2505-0712-0656	7,029.35		117573	CHRAVE DAVIS PAINTING

CITY OF RAMSEY
Create Payment Control Groups

Payment Group Control Number 4041
 Bank Account 999.1010 CASH IN BANK 00002224
 Version LOGIS004V
 Originator JMORRISON
 Payment Instrument Check Payment
 Pay Through Date 8/13/2025

Payee Number	Name / Mailing Address	Stub Message	Document Ty	Number	itm	Co	Due Date	Invoice Number	Payment Amount	Discount Taken	Supplier Number	Supplier Name
	CHRAVE DAVIS PAINTING								7,029.35			
	7400 149TH LANE NW		PV	132912	001	00999	7/16/2025	2507-1609-2888	683.43			
	RAMSEY MN 55303								683.43			
									7,712.78			
110734	CITY OF RAMSEY	Acct #719019	PV	132889	001	00999	7/25/2025	719019 QTR 2 2025	162.63		110734	CITY OF RAMSEY
	CITY OF RAMSEY								162.63			
	P O BOX 251100		PV	132921	001	00999	7/25/2025	735287 QTR 2 2025	32.57			
	ST PAUL MN 55125-6100								32.57			
			PV	132948	001	00999	7/25/2025	726294 QTR 2 2025	57.32			
									57.32			
			PV	132949	001	00999	7/25/2025	727919 QTR 2 2025	2.43			
									2.43			
			PV	132950	001	00999	7/25/2025	724931 QTR 2 2025	72.22			
									72.22			
			PV	132951	001	00999	7/25/2025	724874 QTR 2 2025	157.50			
									157.50			
			PV	132952	001	00999	7/25/2025	724628 QTR 2 2025	153.74			
									153.74			
			PV	132953	001	00999	7/25/2025	723960 QTR 2 2025	153.74			
									153.74			
			PV	132954	001	00999	7/25/2025	724470 QTR 2 2025	42.58			
									42.58			
			PV	132955	001	00999	7/25/2025	737034 QTR 2 2025	77.50			
									77.50			
			PV	132957	001	00999	7/25/2025	444931372 QTR 2	155.11			

Payment Group Control Number 4041
 Bank Account 999.1010 CASH IN BANK 00002224
 Version LOGIS004V
 Originator JMORRISON
 Payment Instrument Check Payment
 Pay Through Date 8/13/2025

Payee Number	Name / Mailing Address	Stub Message	Document Ty Number Itrn Co	Due Date	Invoice Number	Payment Amount	Discount Taken	Supplier Number	Supplier Name
				2025					
			Summary Total			155.11			
			PV 132958 001 00999	7/25/2025	444931294 QTR 2 2025	898.77			
			Summary Total			898.77			
			PV 132959 001 00999	7/25/2025	727918 QTR 2 2025	2.43			
			Summary Total			2.43			
			PV 132968 001 00999	7/25/2025	733061 QTR 2 2025	3,866.40			
			Summary Total			3,866.40			
			PV 132973 001 00999	7/25/2025	722164 QTR 2 2025	2,904.39			
			Summary Total			2,904.39			
			PV 133024 001 00999	7/25/2025	727978 QTR 2 2025	154.84			
			Summary Total			154.84			
			PV 133025 001 00999	7/25/2025	726528 QTR 2 2025	1,284.31			
			Summary Total			1,284.31			
			Payment Amount			10,178.48			
100112	COMMISSIONER OF TRANSPORTATION		PV 132860 001 00999	7/22/2025	P00019931	237.64		100112	COMMISSIONER OF TRANSPORTATION
	COMMISSIONER OF TRANSPORTATION MN DEPT MS 215 -395 JOHN IRELAND BLVD ST PAUL MN 55155		Summary Total			237.64			
			Payment Amount			237.64			
100112	COMMISSIONER OF TRANSPORTATION		PV 132962 001 00999	7/11/2025	P00019816A	1,610.37		100112	COMMISSIONER OF TRANSPORTATION

CITY OF RAMSEY
Create Payment Control Groups

Payment Group Control Number 4041
 Bank Account 999.1010 CASH IN BANK 00002224
 Version LOGIS004V
 Originator JMORRISON
 Payment Instrument Check Payment
 Pay Through Date 8/13/2025

Number	Payee Name / Mailing Address	Stub Message	Document Ty	Number	Itm	Co	Due Date	Invoice Number	Payment Amount	Discount Taken	Supplier Number	Supplier Name
	COMMISSIONER OF TRANSPORTATION MN DEPT MS 215 -395 JOHN IRELAND BLVD ST PAUL MN 55155								Summary Total	1,610.37		
									Payment Amount	1,610.37		
100167	CORNERSTONE FORD CORNERSTONE FORD 17219 HIGHWAY 10 NW PO BOX 304 ELK RIVER MN 55330	EP DISCOUNT TAKEN	PV	132919	001	00999	7/15/2025	15509567	792.58		100167	CORNERSTONE FORD
									Summary Total	792.58		
									Payment Amount	792.58		
113734	CURT KRIENS CONSTRUCTION CURT KRIENS CONSTRUCTION 15740 AZURITE COURT RAMSEY MN 55303		PV	132776	001	00999	7/16/2025	07162025	4,459.00		113734	CURT KRIENS CONSTRUCTION
									Summary Total	4,459.00		
									Payment Amount	4,459.00		
120341	DAMON FARBER ASSOCIATES, INC DAMON FARBER ASSOCIATES, INC 310 SOUTH 4TH AVE STE 7050 MNNEAPOLIS MN 55415		PV	132995	001	00999	7/21/2025	99762	24,686.77		120341	DAMON FARBER ASSOCIATES, INC
									Summary Total	24,686.77		
									Payment Amount	24,686.77		
118837	DODGE OF BURNSVILLE,		PV	132883	001	00999	3/25/2025	N99332	45,995.00		118837	DODGE OF BURNSVILLE

Payment Group Control Number 4041
 Bank Account 999.1010 CASH IN BANK 00002224
 Version LOGIS004V
 Originator JMORRISON
 Payment Instrument Check Payment
 Pay Through Date 8/13/2025

Payee		Stub	Document				Due	Invoice	Payment	Discount	Supplier		
Number	Name / Mailing Address	Message	Ty	Number	Itm	Co	Date	Number	Amount	Taken	Number	Name	
INC											INC		
DODGE OF BURNSVILLE, INC 12101 HIGHWAY 35W SOUTH BURNSVILLE MN 55337			Summary Total							45,995.00			
			Payment Amount							45,995.00			
106624	EHLERS	Inv #102139	PV	132749	001	00999	7/11/2025	102139	3,653.75		106624 EHLERS		
EHLERS 3001 BROADWAY ST NE STE 320 MINNEAPOLIS MN 55413			Summary Total							3,653.75			
		Inv #102138	PV	132750	001	00999	7/11/2025	102138	5,000.00				
		inv #102137	PV	132751	001	00999	7/11/2025	102137	5,000.00				
			Summary Total							5,000.00			
			Payment Amount							13,653.75			
104267	ELITE SANITATION		PV	133000	001	00999	7/28/2025	31900	792.12		104267 ELITE SANITATION		
ELITE SANITATION PO BOX 526 ELK RIVER MN 55330			Summary Total							792.12			
			Payment Amount							792.12			
110760	FIRE SAFETY USA, INC		PV	132815	001	00999	7/21/2025	203963	635.70		110760 FIRE SAFETY USA, INC		
FIRE SAFETY USA, INC 3253 19TH STREET NW ROCHESTER MN 55901			Summary Total							635.70			
			PV	132816	001	00999	7/21/2025	203962	609.45				
			Summary Total							609.45			
			PV	132817	001	00999	7/21/2025	203664	5,468.75				

CITY OF RAMSEY
Create Payment Control Groups

Payment Group Control Number 4041
 Bank Account 999.1010 CASH IN BANK 00002224
 Version LOGIS004V
 Originator JMORRISON
 Payment Instrument Check Payment
 Pay Through Date 8/13/2025

Payee Number	Name / Mailing Address	Stub Message	Document Ty	Number	Item	Co	Due Date	Invoice Number	Payment Amount	Discount Taken	Supplier Number	Supplier Name	
Summary Total									5,468.75				
			PV	132818	001	00999	7/21/2025	203964	2,268.00				
Summary Total									2,268.00				
Payment Amount									8,981.90				
117332	HEARTLAND TIRE INC		PV	132838	001	00999	7/9/2025	9047769	176.99		117332	HEARTLAND TIRE INC	
	HEARTLAND TIRE INC		Summary Total									176.99	
	7151 RIVERDALE DRIVE NW		PV	132969	001	00999	7/28/2025	9048118	137.00				
	RAMSEY MN 55303		Summary Total									137.00	
		PD STOCK	PV	133005	001	00999	7/29/2025	9048134	548.00				
Summary Total									548.00				
Payment Amount									861.99				
117451	INKY ELF LLC		PV	132980	001	00999	7/31/2025	14204	209.71		117451	INKY ELF LLC	
	INKY ELF LLC		Summary Total									209.71	
	P O BOX 819		Payment Amount									209.71	
	ANOKA MN 55303												
118015	INTERSTATE TESTING LLC		PV	132763	001	00999	7/8/2025	17562	1,900.00		118015	INTERSTATE TESTING LLC	
	INTERSTATE TESTING LLC		Summary Total									1,900.00	
	P O BOX 55		Payment Amount									1,900.00	
	ANOKA MN 55303												

Payment Group Control Number 4041
 Bank Account 999.1010 CASH IN BANK 00002224
 Version LOGIS004V
 Originator JMORRISON
 Payment Instrument Check Payment
 Pay Through Date 8/13/2025

Payee		Stub	Document				Due	Invoice	Payment	Discount	Supplier	
Number	Name / Mailing Address	Message	Ty	Number	Itm	Co	Date	Number	Amount	Taken	Number	Name
122127	KIDCREATE STUDIO NORTH METRO		PV	133016	001	00999	7/30/2025	1156 V1	1,184.00		122127	KIDCREATE STUDIO NORTH METRO
	KIDCREATE STUDIO NORTH METRO			Summary Total					1,184.00			
	4609 121ST AVE NE		PV	133017	001	00999	7/30/2025	1157 V1	1,184.00			
	BLAINE MN 55449			Summary Total					1,184.00			
				Payment Amount					2,368.00			
100256	LANO EQUIPMENT INC		PV	132826	001	00999	7/7/2025	02-1166150	145.90		100256	LANO EQUIPMENT INC
	LANO EQUIPMENT INC			Summary Total					145.90			
	6140 HIGHWAY 10 NW		PV	132943	001	00999	7/21/2025	02-1169817	41.23			
	ANOKA MN 55303			Summary Total					41.23			
			PV	132966	001	00999	7/24/2025	02-1170875	162.47			
				Summary Total					162.47			
				Payment Amount					349.60			
121779	LB CARLSON LLP	Inv# 250034	PV	132753	001	00999	7/14/2025	250034	1,569.95		121779	LB CARLSON LLP
	LB CARLSON LLP			Summary Total					1,569.95			
	605 HIGHWAY US 169 N	Inv #250010	PV	132767	001	00999	7/14/2025	250010	3,009.95			
	STE 650			Summary Total					3,009.95			
	MINNEAPOLIS MN 55441			Payment Amount					4,579.90			
122117	LETS LLC		PV	132882	001	00999	7/23/2025	07232025	175.00		122117	LETS LLC
	LETS LLC			Summary Total					175.00			
	12584 QUEMOY ST NE											
	BLAINE MN 55449-6119											

CITY OF RAMSEY
Create Payment Control Groups

Payment Group Control Number 4041
 Bank Account 999.1010 CASH IN BANK 00002224
 Version LOGIS004V
 Originator JMORRISON
 Payment Instrument Check Payment
 Pay Through Date 8/13/2025

Payee		Stub	Document			Due	Invoice	Payment	Discount	Supplier		
Number	Name / Mailing Address	Message	Ty	Number	Itm	Co	Date	Number	Amount	Taken	Number	Name
Payment Amount									175.00			
100270	MACQUEEN		PV	132819	001	00999	7/18/2025	P52076	3,360.50		100270	MACQUEEN
	MACQUEEN			Summary Total					3,360.50			
	1125 7TH STREET E		PV	133007	001	00999	7/31/2025	P66527	335.96			
	ST PAUL MN 55106			Summary Total					335.96			
Payment Amount									3,696.46			
120041	MARTIN MARIETTA		PV	132833	001	00999	7/11/2025	46414504	116.25		120041	MARTIN MARIETTA
	MARTIN MARIETTA			Summary Total					116.25			
	PO BOX 93186		PV	132834	001	00999	7/10/2025	46399897	156.55			
	CHICAGO IL 60673-3186			Summary Total					156.55			
			PV	132936	001	00999	7/18/2025	46493250	486.51			
				Summary Total					486.51			
			PV	132967	001	00999	7/25/2025	46573625	280.56			
				Summary Total					280.56			
			PV	133008	001	00999	7/29/2025	46608885	745.55			
				Summary Total					745.55			
			PV	133009	001	00999	7/29/2025	46609142	529.34			
				Summary Total					529.34			
			PV	133012	001	00999	7/30/2025	46626417	170.05			
				Summary Total					170.05			
Payment Amount									2,484.81			
117588	MEDART INC		PV	132929	001	00999	7/24/2025	224576-00	57.24		117588	MEDART INC

Payment Group Control Number 4041
 Bank Account 999.1010 CASH IN BANK 00002224
 Version LOGIS004V
 Originator JMORRISON
 Payment Instrument Check Payment
 Pay Through Date 8/13/2025

Payee Number	Stub Message	Document Ty	Number	Itm	Co	Due Date	Invoice Number	Payment Amount	Discount Taken	Supplier Number	Supplier Name
MEDART INC 124 MANUFACTURERS DRIVE ARNOLD MO 63010-4727								Summary Total 57.24 759.42			
		PV	132944	001	00999	7/22/2025	220259-00				
								Summary Total 759.42			
								Payment Amount 816.66			
120187 MIDWEST OVERHEAD CRANES CORP MIDWEST OVERHEAD CRANES CORP 1134 SALEM PARKWAY SALEM OH 44460								Summary Total 728.78		120187	MIDWEST OVERHEAD CRANES CORP
		PV	132830	001	00999	7/18/2025	182242				
								Summary Total 728.78			
								Payment Amount 728.78			
101164 MILLER CHEVROLET LLC MILLER CHEVROLET 21150 JOHN MILLESS DRIVE ROGERS MN 55374								Summary Total 469.64		101164	MILLER CHEVROLET LL
		PV	132979	001	00999	7/30/2025	748823				
								Summary Total 469.64			
								Payment Amount 469.64			
102216 MN DEPT OF TRANSPORTATION MINNESOTA DEPT OF TRANSPORTATION MS-215 395 JOHN IRELAND BLVD ST PAUL MN 55155								Summary Total 100.00		102216	MN DEPT OF TRANSPORTATION
		PV	132925	001	00999	7/21/2025	00000879560				
								Summary Total 100.00			
								Payment Amount 100.00			
118518 POMPS TIRE SERVICE INC								Summary Total 846.35		118518	POMPS TIRE SERVICE INC
		PV	132971	001	00999	7/29/2025	150194231				

CITY OF RAMSEY
Create Payment Control Groups

Payment Group Control Number 4041
 Bank Account 999.1010 CASH IN BANK 00002224
 Version LOGIS004V
 Originator JMORRISON
 Payment Instrument Check Payment
 Pay Through Date 8/13/2025

Payee		Stub	Document			Due	Invoice	Payment	Discount	Supplier		
Number	Name / Mailing Address	Message	Ty	Number	Itm	Co	Date	Number	Amount	Taken	Number	Name
	POMPS TIRE SERVICE INC PO BOX 88697 MILWAUKEE WI 53288-8697			Summary Total					846.35			
				Payment Amount					846.35			
112959	PREMIUM WATERS INC PREMIUM WATERS INC P O BOX 9128 MINNEAPOLIS MN 55480-9128		PV	132770	001	00999	6/30/2025	621332-06-25	26.25		112959	PREMIUM WATERS INC
				Summary Total					26.25			
			PV	132771	001	00999	6/30/2025	621331-06-25	55.60			
				Summary Total					55.60			
				Payment Amount					81.85			
120681	RECYCLE TECHNOLOGIES RECYCLE TECHNOLOGIES 1525 99TH LANE NE BLAINE MN 55449	Recycling Ink Jet & Toner	PV	132879	001	00999	5/31/2025	256377	28.50		120681	RECYCLE TECHNOLOGI
				Summary Total					28.50			
				Payment Amount					28.50			
110794	SCHMIDT CURB COMPANY INC SCHMIDT CURB COMPANY INC 13195 95TH STREET NE ELK RIVER MN 55330		PV	132829	001	00999	7/15/2025	25-25 C	9,890.00		110794	SCHMIDT CURB COMPA INC
				Summary Total					9,890.00			
				Payment Amount					9,890.00			
118921	SHRED RIGHT		PV	132947	001	00999	7/17/2025	0052947	18.85		118921	SHRED RIGHT

Payment Group Control Number 4041
 Bank Account 999.1010 CASH IN BANK 00002224
 Version LOGIS004V
 Originator JMORRISON
 Payment Instrument Check Payment
 Pay Through Date 8/13/2025

Payee Number	Name / Mailing Address	Stub Message	Document Ty	Number Number	Itm	Co	Due Date	Invoice Number	Payment Amount	Discount Taken	Supplier Number	Name
	SHRED RIGHT 6301 W OLD SHAKOPEE ROAD SUITE A BLOOMINGTON MN 55438								18.85			
									Summary Total			
									Payment Amount	18.85		
100446	SILENT KNIGHT SECURITY INC	6701 Hwy 10 Property Mgmt	PV	132850	001	00999	7/21/2025	161150	160.00		100446	SILENT KNIGHT SECURITY INC
	SILENT KNIGHT SECURITY INC 3387 BROWNLOW AVE ST LOUIS PARK MN 55426								Summary Total	160.00		
									Payment Amount	160.00		
114151	TASC (FEES)		PV	132848	001	00999	7/21/2025	IN3506012	231.25		114151	TASC (FEES)
	TASC CLIENT INVOICES P O BOX 88278 MILWAUKEE WI 53288-0001								Summary Total	231.25		
									Payment Amount	231.25		
115935	UNITED STATES GEOLOGICAL SURVEY	90115875	PV	132976	001	00999	7/10/2025	600006026	1,875.00		115935	UNITED STATES GEOLOGICAL SURVEY
	UNITED STATES GEOLOGICAL SURVEY PO BOX 6200-27 PORTLAND OR 97228-6200								Summary Total	1,875.00		
									Payment Amount	1,875.00		
112319	VESSCO INC		PV	132764	001	00999	7/18/2025	098224	2,172.65		112319	VESSCO INC

Payment Group Control Number 4041
 Bank Account 999.1010 CASH IN BANK 00002224
 Version LOGIS004V
 Originator JMORRISON
 Payment Instrument Check Payment
 Pay Through Date 8/13/2025

Payee		Stub	Document		Due	Invoice	Payment	Discount	Supplier			
Number	Name / Mailing Address	Message	Ty	Number	Itm	Co	Date	Number	Amount	Taken	Number	Name
	VESSCO INC											
	8217 UPLAND CIRCLE											
	CHANHASSEN MN 55317											
Summary Total									2,172.65			
Payment Amount									2,172.65			
Total Amount to be Processed									163,171.34			
Total Number of Payments to be Processed									43			

Payment Group Control Number 4042
 Bank Account 999.1010 CASH IN BANK 00002224
 Version LOGIS004V
 Originator JMORRISON
 Payment Instrument T A/P ACH Payment
 Pay Through Date 8/13/2025

Payee		Stub	Document				Due	Invoice	Payment	Discount	Supplier	
Number	Name / Mailing Address	Message	Ty	Number	Itm	Co	Date	Number	Amount	Taken	Number	Name
110789	4IMPRINT		PV	132755	001	00999	7/10/2025	14034238	783.47		110789	4IMPRINT
	4IMPRINT			Summary Total					783.47			
	25303 NETWORK PLACE											
	CHICAGO IL 60673-1253											
				Payment Amount					783.47			
100011	ACE SALES		PV	132862	001	00999	7/23/2025	2080A	830.00		100011	ACE SALES
	ACE SALES			Summary Total					830.00			
	17555 UNICORN STREET NW		PV	132978	001	00999	7/30/2025	2081	2,935.00			
	RAMSEY MN 55303			Summary Total					2,935.00			
				Payment Amount					3,765.00			
117343	AMAZON CAPITAL SERVICES INC		PV	132809	001	00999	7/21/2025	16VY-QNHH-1YG7	317.45		117343	AMAZON CAPITAL SERVICES INC
	AMAZON CAPITAL SERVICES INC			Summary Total					317.45			
	PO BOX 035184		PD	132812	001	00999	8/13/2025	1TVL-HCJ7-3FCW	6.99-			
	SEATTLE WA 98124-5184			Summary Total					6.99-			
			PV	132814	001	00999	7/19/2025	14RH-3J4N-WTMV	81.65			
				Summary Total					81.65			
			PV	132885	001	00999	7/24/2025	1Q7J-H1XC-4GTG	53.79			
				Summary Total					53.79			
			PV	132934	001	00999	7/21/2025	16FR-GJ1X-1VXN	115.57			
				Summary Total					115.57			
				Payment Amount					561.47			
109256	AMERICAN ENGINEERING		PV	132839	001	00999	7/18/2025	INV-270002	1,716.00		109256	AMERICAN ENGINEERIN

CITY OF RAMSEY
Create Payment Control Groups

Payment Group Control Number 4042
 Bank Account 999.1010 CASH IN BANK 00002224
 Version LOGIS004V
 Originator JMORRISON
 Payment Instrument T A/P ACH Payment
 Pay Through Date 8/13/2025

Payee		Stub	Document			Due	Invoice	Payment	Discount	Supplier		
Number	Name / Mailing Address	Message	Ty	Number	Itm	Co	Date	Number	Amount	Taken	Number	Name
	TESTING INC											TESTING INC
	AMERICAN ENGINEERING TESTING INC			Summary Total					1,716.00			
	LOCKBOX 170023 PO BOX		PV	132852	001	00999	7/18/2025	INV-270341	2,745.00			
	1691											
	MINNEAPOLIS MN 55480-1691			Summary Total					2,745.00			
			PV	132853	001	00999	7/22/2025	INV-271402	2,594.50			
				Summary Total					2,594.50			
			PV	132854	001	00999	7/22/2025	INV-271099	1,341.00			
				Summary Total					1,341.00			
			PV	132855	001	00999	7/22/2025	INV-270994	1,000.00			
				Summary Total					1,000.00			
			PV	132856	001	00999	7/22/2025	INV-271227	2,655.50			
				Summary Total					2,655.50			
			PV	132857	001	00999	7/22/2025	INV-271495	4,515.00			
				Summary Total					4,515.00			
			PV	132964	001	00999	7/22/2025	INV-271386	11,798.00			
				Summary Total					11,798.00			
			PV	132977	001	00999	7/31/2025	INV-272841	3,528.75			
				Summary Total					3,528.75			
			PV	133003	001	00999	7/31/2025	INV-273845	870.00			
				Summary Total					870.00			
				Payment Amount					32,763.75			
100043	ANOKA COUNTY PROPERTY RECORDS TAXATION	Recording	PV	133015	001	00999	7/31/2025	25-31764/25-32449	132.00			100043 ANOKA COUNTY PROPERTY RECORDS TAXATION

Payment Group Control Number 4042
 Bank Account 999.1010 CASH IN BANK 00002224
 Version LOGIS004V
 Originator JMORRISON
 Payment Instrument T A/P ACH Payment
 Pay Through Date 8/13/2025

Payee		Stub	Document				Due	Invoice	Payment	Discount	Supplier	
Number	Name / Mailing Address	Message	Ty	Number	Itm	Co	Date	Number	Amount	Taken	Number	Name
	ANOKA COUNTY PROPERTY RECORDS TAXATION 2100 - 3RD AVENUE ANOKA MN 55303			Summary Total					132.00			
				Payment Amount					132.00			
107587	ANOKA COUNTY TREASURY DEPARTMENT ANOKA COUNTY TREASURY DEPARTMENT 2100 3RD AVE STE 300 ANOKA MN 55303-5029		PV	132748	001	00999	7/11/2025	B250710M	492.00		107587	ANOKA COUNTY TREASURY DEPARTMEN
				Summary Total					492.00			
			PV	132926	001	00999	7/24/2025	HWYSQ12025	439.89			
				Summary Total					439.89			
			PV	132983	001	00999	7/31/2025	AR023348	426.00			
				Summary Total					426.00			
				Payment Amount					1,357.89			
106346	BAUER BUILT INCORPORATED BAUER BUILT INCORPORATED 8270 W 35W SERVICE DR NE BLAINE MN 55449		PV	132938	001	00999	7/21/2025	940122410	1,367.00		106346	BAUER BUILT INCORPORATED
				Summary Total					1,367.00			
				Payment Amount					1,367.00			
116848	BAYCOM INC BAYCOM INC PO BOX 88013 MILWAUKEE WI 53288-8013		PV	132808	001	00999	7/21/2025	EQUIPINV_056647	7,480.00		116848	BAYCOM INC
				Summary Total					7,480.00			
				Payment Amount					7,480.00			

CITY OF RAMSEY
Create Payment Control Groups

Payment Group Control Number 4042
 Bank Account 999.1010 CASH IN BANK 00002224
 Version LOGIS004V
 Originator JMORRISON
 Payment Instrument T A/P ACH Payment
 Pay Through Date 8/13/2025

Payee Number	Name / Mailing Address	Stub Message	Document Ty	Number	Itm	Co	Due Date	Invoice Number	Payment Amount	Discount Taken	Supplier Number	Name
120954	BE FREE BE YOURSELF LLC		PV	132810	001	00999	7/10/2025	7	250.00		120954	BE FREE BE YOURSELF LLC
	BE FREE BE YOURSELF LLC							Summary Total	250.00			
	2221 180TH AVE NW							Payment Amount	250.00			
	ANDOVER MN 55304											
100647	BOLTON AND MENK INC	NORTHFORK TRL STAKING/PLAT FEE	PV	132774	001	00999	7/10/2025	0367439	269.60		100647	BOLTON AND MENK INC
	BOLTON AND MENK INC							Summary Total	269.60			
	1960 PREMIER DRIVE		PV	132858	001	00999	7/10/2025	0367438	1,462.50			
	MANKATO MN 56001-5900							Summary Total	1,462.50			
			PV	132859	001	00999	7/10/2025	0367435	2,203.00			
								Summary Total	2,203.00			
			PV	132914	001	00999	7/10/2025	0367437	14,518.00			
								Summary Total	14,518.00			
			PV	132915	001	00999	7/10/2025	0367434	7,312.50			
								Summary Total	7,312.50			
			PV	132945	001	00999	7/10/2025	0367440	1,929.50			
								Summary Total	1,929.50			
								Payment Amount	27,695.10			
116197	CINTAS CORPORATION		PV	132831	001	00999	7/17/2025	4237218524	45.01		116197	CINTAS CORPORATION
	CINTAS CORPORATION							Summary Total	45.01			
	CINTAS LOC #4K		PV	132887	001	00999	7/25/2025	4238106174	60.14			

Payment Group Control Number 4042
 Bank Account 999.1010 CASH IN BANK 00002224
 Version LOGIS004V
 Originator JMORRISON
 Payment Instrument T A/P ACH Payment
 Pay Through Date 8/13/2025

Payee Number	Stub Message	Document Ty Number Itm Co	Due Date	Invoice Number	Payment Amount	Discount Taken	Supplier Number	Supplier Name
P O BOX 650838 DALLAS TX 75265-0838		Summary Total			60.14			
		PV 132928 001 00999	7/24/2025	4238011639	101.55			
		Summary Total			101.55			
		PV 133013 001 00999	7/31/2025	4238705995	45.01			
		Summary Total			45.01			
		Payment Amount			251.71			
122113 CIVILGEO INC CIVILGEO INC 708 HEARTLAND TRAIL 3RD FLOOR MADISON WI 53717		PV 132847 001 00999	7/23/2025	28356	2,995.00		122113 CIVILGEO INC	
		Summary Total			2,995.00			
		Payment Amount			2,995.00			
114117 CRAWFORD'S EQUIPMENT INC CRAWFORD'S EQUIPMENT INC 4898 HIGHWAY 95 NW CAMBRIDGE MN 55008		PV 132823 001 00999	7/16/2025	01-107334	14.01		114117 CRAWFORD'S EQUIPME INC	
		Summary Total			14.01			
		PV 132933 001 00999	7/21/2025	01-107502	373.19			
		Summary Total			373.19			
		PV 132939 001 00999	7/21/2025	01-107518	124.24			
		Summary Total			124.24			
		PV 132940 001 00999	6/30/2025	01-106747	486.39			
		Summary Total			486.39			
		Payment Amount			997.83			
100141 DAVE PERKINS CONTRACTING INC		PV 132861 001 00999	7/18/2025	13141	5,350.00		100141 DAVE PERKINS CONTRACTING INC	

CITY OF RAMSEY
Create Payment Control Groups

Payment Group Control Number 4042
 Bank Account 999.1010 CASH IN BANK 00002224
 Version LOGIS004V
 Originator JMORRISON
 Payment Instrument T A/P ACH Payment
 Pay Through Date 8/13/2025

Payee		Stub	Document			Due	Invoice	Payment	Discount	Supplier		
Number	Name / Mailing Address	Message	Ty	Number	Itm	Co	Date	Number	Amount	Taken	Number	Name
	DAVE PERKINS CONTRACTING INC 19745 NOWTHEN BLVD NW ANOKA MN 55303-9655			Summary Total					5,350.00			
			PV	132918	001	00999	7/29/2025	13148	3,502.00			
				Summary Total					3,502.00			
				Payment Amount					8,852.00			
113306	DEFINITIVE TECHNOLOGY SOLUTIONS INC 9401 JAMES AVENUE SOUTH SUITE 162 BLOOMINGTON MN 55431-2549			Summary Total					812.91		113306	DEFINITIVE TECHNOLOGY SOLUTIONS INC
			PV	132849	001	00999	7/22/2025	INV295927	812.91			
				Summary Total					812.91			
				Payment Amount					812.91			
100144	DEHN OIL COMPANY 6735 141ST AVENUE NW RAMSEY MN 55303			Summary Total					2,477.60		100144	DEHN OIL COMPANY
			PV	132835	001	00999	7/10/2025	116686	2,477.60			
				Summary Total					2,477.60			
			PV	132923	001	00999	7/22/2025	116786	4,618.05			
				Summary Total					4,618.05			
			PV	132924	001	00999	7/22/2025	116785	2,414.30			
				Summary Total					2,414.30			
			PV	132932	001	00999	7/16/2025	116753	2,445.60			
				Summary Total					2,445.60			
			PV	132970	001	00999	7/28/2025	116825	2,382.30			
				Summary Total					2,382.30			
				Payment Amount					14,337.85			
117489	DISPLAY SALES COMPANY			Summary Total					3,585.00		117489	DISPLAY SALES
			PV	133006	001	00999	7/30/2025	INV7672	3,585.00			

Payment Group Control Number 4042
 Bank Account 999.1010 CASH IN BANK 00002224
 Version LOGIS004V
 Originator JMORRISON
 Payment Instrument T A/P ACH Payment
 Pay Through Date 8/13/2025

Payee Number	Name / Mailing Address	Stub Message	Document Ty Number Itm Co	Due Date	Invoice Number	Payment Amount	Discount Taken	Supplier Number	Supplier Name
COMPANY									
	DISPLAY SALES COMPANY 6300 W OLD SHAKOPEE ROAD STE 112 BLOOMINGTON MN 55438					Summary Total 3,585.00			
						Payment Amount 3,585.00			
100158	ECM PUBLISHERS INC ECM PUBLISHERS INC 4095 COON RAPIDS BLVD COON RAPIDS MN 55433	Inv #1057418	PV 132752 001 00999	7/11/2025	1057418	269.50		100158	ECM PUBLISHERS INC
						Summary Total 269.50			
			PV 132985 001 00999	7/25/2025	1059067	132.00			
						Summary Total 132.00			
		Anoka Area Chamber Map Ad	PV 132996 001 00999	7/27/2025	1059353	350.00			
						Summary Total 350.00			
						Payment Amount 751.50			
119694	ELK RIVER PRINTING ELK RIVER PRINTING 596 DODGE AVE NW ELK RIVER MN 55330		PV 132881 001 00999	7/18/2025	197577	570.82		119694	ELK RIVER PRINTING
						Summary Total 570.82			
						Payment Amount 570.82			
108737	EMERGENCY AUTOMOTIVE TECHNOLOGY INC EMERGENCY AUTOMOTIVE TECHNOLOGY INC 2755 GENEVA AVE N	WHELAN SURFACE MOUNT	PV 132756 001 00999	7/15/2025	DL06162520G	98.02		108737	EMERGENCY AUTOMOT TECHNOLOGY INC
						Summary Total 98.02			
		WHELAN SURFACE MOUNT SMOKED	PV 132758 001 00999	7/16/2025	DL06162520H	98.02			

CITY OF RAMSEY
Create Payment Control Groups

Payment Group Control Number 4042
 Bank Account 999.1010 CASH IN BANK 00002224
 Version LOGIS004V
 Originator JMORRISON
 Payment Instrument T A/P ACH Payment
 Pay Through Date 8/13/2025

Payee Number	Name / Mailing Address	Stub Message	Document Ty	Number	Itm	Co	Due Date	Invoice Number	Payment Amount	Discount Taken	Supplier Number	Supplier Name
	OAKDALE MN 55128								98.02			
		Summary Total							182.12			
		WHELAN RED/WHITE SMOKED LIGHT	PV	132760	001	00999	7/17/2025	DL061625201				
		Summary Total							182.12			
		Payment Amount							378.16			
113321	FACTORY MOTOR PARTS CO		PV	132824	001	00999	7/15/2025	6-1700623	27.84		113321	FACTORY MOTOR PART. CO
	FACTORY MOTOR PARTS CO BIN 139107 P O BOX 9107 MINNEAPOLIS MN 55480-9107								27.84			
		Summary Total							27.84			
		Payment Amount							27.84			
100143	FERGUSON WATERWORKS # 2518		PV	132746	001	00999	7/9/2025	0546068	8,378.80		100143	FERGUSON WATERWOF # 2518
	FERGUSON WATERWORKS 2516 P O BOX 802817								8,378.80			
		Summary Total							2,863.52			
	CHICAGO IL 60680-2817		PV	132974	001	00999	7/28/2025	0552130				
		Summary Total							2,863.52			
		Payment Amount							295.18			
		Summary Total							295.18			
		Payment Amount							11,537.50			
100650	GRAINGER		PV	132773	001	00999	7/17/2025	9576375589	160.68		100650	GRAINGER
	GRAINGER INC DEPT. 806511127								160.68			
		Summary Total							160.68			
		Payment Amount							2.32			
		Summary Total							2.32			

Payment Group Control Number 4042
 Bank Account 999.1010 CASH IN BANK 00002224
 Version LOGIS004V
 Originator JMORRISON
 Payment Instrument T A/P ACH Payment
 Pay Through Date 8/13/2025

Payee Number Name / Mailing Address	Stub Message	Document Ty Number Itm Co	Due Date	Invoice Number	Payment Amount	Discount Taken	Supplier Number Name
PALATINE IL 60038-0001					2.32		
		Summary Total			163.00		
100209 HAKANSON ANDERSON ASSOC INC		PV 132916 001 00999	7/21/2025	55410	1,587.00		100209 HAKANSON ANDERSON ASSOC INC
HAKANSON ANDERSON ASSOC INC 3601 THURSTON AVENUE		Summary Total			1,587.00		
		PV 132917 001 00999	7/22/2025	55421	5,560.00		
ANOKA MN 55303-1063		Summary Total			5,560.00		
		PV 132963 001 00999	7/15/2025	55323	29,284.00		
		Summary Total			29,284.00		
		Payment Amount			36,431.00		
100211 HAWKINS INC		PV 132745 001 00999	7/15/2025	7131350	60.00		100211 HAWKINS INC
HAWKINS INC P O BOX 860263		Summary Total			60.00		
		PV 132851 001 00999	7/18/2025	7140038	12,472.26		
MINNEAPOLIS MN 55486-0263		Summary Total			12,472.26		
		Payment Amount			12,532.26		
119617 HIRSHFIELD'S		PV 133002 001 00999	7/30/2025	22194891	93.96		119617 HIRSHFIELD'S
HIRSHFIELD'S 725 2ND AVENUE N MINNEAPOLIS MN 55405		Summary Total			93.96		
		Payment Amount			93.96		
112160 HOLIDAY COMPANIES		PV 132982 001 00999	8/1/2025	046801082500	212.50		112160 HOLIDAY COMPANIES

CITY OF RAMSEY
Create Payment Control Groups

Payment Group Control Number 4042
 Bank Account 999.1010 CASH IN BANK 00002224
 Version LOGIS004V
 Originator JMORRISON
 Payment Instrument T A/P ACH Payment
 Pay Through Date 8/13/2025

Payee		Stub	Document			Due	Invoice	Payment	Discount	Supplier		
Number	Name / Mailing Address	Message	Ty	Number	Itm	Co	Date	Number	Amount	Taken	Number	Name
	HOLIDAY COMPANIES 6000 CLEARWATER DR STE 300 MINNETONKA MN 55343			Summary Total					212.50			
				Payment Amount					212.50			
114068	IDEAL SERVICE INC IDEAL SERVICE INC P O BOX 244 ALEXANDRIA MN 56308		PV	132821	001	00999	6/27/2025	13525	682.50		114068	IDEAL SERVICE INC
				Summary Total					682.50			
				Payment Amount					682.50			
112475	INNOVATIVE OFFICE SOLUTIONS INNOVATIVE OFFICE SOLUTIONS LOCKBOX 131434 P O BOX 1414 MINNEAPOLIS MN 55480-1414	S27569	PV	132805	001	00999	7/21/2025	IN4888022	102.13		112475	INNOVATIVE OFFICE SOLUTIONS
				Summary Total					102.13			
		S27569	PV	132888	001	00999	7/22/2025	IN4888976	15.43			
				Summary Total					15.43			
				Payment Amount					117.56			
100258	LEAGUE OF MINNESOTA CITIES LEAGUE OF MN CITIES FINANCE DEPT 145 UNIVERSITY AVE WEST ST PAUL MN 55103-2044		PV	132994	001	00999	7/22/2025	432000	15.00		100258	LEAGUE OF MINNESOTA CITIES
				Summary Total					15.00			
				Payment Amount					15.00			

Payment Group Control Number 4042
 Bank Account 999.1010 CASH IN BANK 00002224
 Version LOGIS004V
 Originator JMORRISON
 Payment Instrument T A/P ACH Payment
 Pay Through Date 8/13/2025

Payee		Stub	Document				Due	Invoice	Payment	Discount	Supplier	
Number	Name / Mailing Address	Message	Ty	Number	Itm	Co	Date	Number	Amount	Taken	Number	Name
100266	LOGIS		PV	132807	001	00999	7/18/2025	152303	917.08		100266	LOGIS
	LOCAL GOVERNMENT INFORMATION SYSTEMS ASS			Summary Total					917.08			
	5750 DULUTH STREET		PV	132822	001	00999	7/21/2025	152377	77,492.00			
	GOLDEN VALLEY MN 55422-4036			Summary Total					77,492.00			
				Payment Amount					78,409.08			
117425	MAUER MAIN CHEVROLET		PV	132827	001	00999	7/10/2025	5308415	43.40		117425	MAUER MAIN CHEVROL
	MAUER MAIN CHEVROLET			Summary Total					43.40			
	435 WEST MAIN STREET		PV	132828	001	00999	7/8/2025	5308457	83.20			
	ANOKA MN 55303			Summary Total					83.20			
			PV	132927	001	00999	7/22/2025	5308590	669.61			
				Summary Total					669.61			
				Payment Amount					796.21			
100283	MENARDS COON RAPIDS		PV	132769	001	00999	7/15/2025	45941	25.13		100283	MENARDS COON RAPID
	MENARDS COON RAPIDS			Summary Total					25.13			
	3045 MAIN STREET		PV	132845	001	00999	7/22/2025	46376	271.59			
	COON RAPIDS MN 55448			Summary Total					271.59			
			PV	132930	001	00999	7/24/2025	46491	329.99			
				Summary Total					329.99			
				Payment Amount					626.71			
100284	MENARDS ELK RIVER		PV	132762	001	00999	7/7/2025	18795	383.43		100284	MENARDS ELK RIVER
	MENARDS ELK RIVER			Summary Total					383.43			
	19521 EVANS STREET NW		PV	132813	001	00999	7/18/2025	19515	141.24			

CITY OF RAMSEY
Create Payment Control Groups

Payment Group Control Number 4042
 Bank Account 999.1010 CASH IN BANK 00002224
 Version LOGIS004V
 Originator JMORRISON
 Payment Instrument T A/P ACH Payment
 Pay Through Date 8/13/2025

Payee		Stub	Document				Due	Invoice	Payment	Discount	Supplier	
Number	Name / Mailing Address	Message	Ty	Number	Itm	Co	Date	Number	Amount	Taken	Number	Name
ELK RIVER MN 55330-1077			Summary Total						141.24			
			PV	132886	001	00999	7/26/2025	20045	116.29			
			Summary Total						116.29			
			PV	132935	001	00999	7/16/2025	19375	87.44			
			Summary Total						87.44			
			PV	132956	001	00999	7/21/2025	19670	183.75			
			Summary Total						183.75			
			Payment Amount						912.15			
119825 METRO CREATIVE GRAPHICS INC			PV	132993	001	00999	7/31/2025	408050	99.00		119825	METRO CREATIVE GRAPHICS INC
METRO CREATIVE GRAPHICS INC PO BOX 2085 LIVINGSTON NJ 07039			Summary Total						99.00			
			Payment Amount						99.00			
108208 METRO PRODUCTS LLC			PV	132825	001	00999	7/10/2025	187191	67.08		108208	METRO PRODUCTS LLC
METRO PRODUCTS LLC 7401 CENTRAL AVENUE NE FRIDLEY MN 55432			Summary Total						67.08			
			PV	132837	001	00999	7/10/2025	187190	27.20			
			Summary Total						27.20			
			PV	132922	001	00999	7/17/2025	187317	538.67			
			Summary Total						538.67			
			Payment Amount						632.95			
103915 MICHAEL BASICH INC. MICHAEL BASICH INC.			PV	132768	001	00999	7/12/2025	71225-2	54,000.00		103915	MICHAEL BASICH INC.
			Summary Total						54,000.00			

CITY OF RAMSEY
Create Payment Control Groups

Payment Group Control Number 4042
 Bank Account 999.1010 CASH IN BANK 00002224
 Version LOGIS004V
 Originator JMORRISON
 Payment Instrument T A/P ACH Payment
 Pay Through Date 8/13/2025

Payee		Stub	Document			Due	Invoice	Payment	Discount	Supplier	
Number	Name / Mailing Address	Message	Ty	Number	Itm	Co	Date	Number	Taken	Number	Name
121934	NITTY GRITTY PICKLEBALL		PV	132965	001	00999	7/27/2025	2025-21			121934 NITTY GRITTY PICKLEBALL
	NITTY GRITTY PICKLEBALL								165.00		
	6050 RAWLINGS AVE NE										
	ROGERS MN 55374										
									Summary Total		165.00
									Payment Amount		165.00
100363	NORTHERN SANITARY SUPPLY CO		PV	132841	001	00999	7/23/2025	104647			100363 NORTHERN SANITARY SUPPLY CO
	NORTHERN SANITARY SUPPLY CO								512.30		
	341 COON RAPIDS BLVD										
	MINNEAPOLIS MN 55433										
									Summary Total		512.30
			PV	132842	001	00999	7/23/2025	104683			501.15
									Summary Total		501.15
			PV	132960	001	00999	7/29/2025	104683A			69.45
									Summary Total		69.45
									Payment Amount		1,082.90
115071	NORTHLAND OCCUPATIONAL HEALTH		PV	132984	001	00999	7/29/2025	256947			115071 NORTHLAND OCCUPATIONAL HEALTH
	NORTHLAND OCCUPATIONAL HEALTH								200.00		
	7533 SUNWOOD DRIVE NW										
	SUITE 212										
	RAMSEY MN 55303										
									Summary Total		200.00
			PV	132991	001	00999	7/31/2025	256959			50.00
									Summary Total		50.00
			PV	132992	001	00999	7/31/2025	256957			100.00
									Summary Total		100.00
									Payment Amount		350.00

Payment Group Control Number 4042
 Bank Account 999.1010 CASH IN BANK 00002224
 Version LOGIS004V
 Originator JMORRISON
 Payment Instrument T A/P ACH Payment
 Pay Through Date 8/13/2025

Payee Number	Name / Mailing Address	Stub Message	Document Ty Number Itm Co	Due Date	Invoice Number	Payment Amount	Discount Taken	Supplier Number	Supplier Name
110547	NORTHWEST LIGHTING SYSTEMS CO. NORTHWEST LIGHTING SYSTEMS CO. 736 CRAIG AVENUE TRACY MN 56175		PV 132997 001 00999	7/1/2025	137588	168.00		110547	NORTHWEST LIGHTING SYSTEMS CO.
					Summary Total	168.00			
					Payment Amount	168.00			
110480	OPUS 21 MANAGEMENT SOLUTIONS OPUS 21 MANAGEMENT SOLUTIONS 680 COMMERCE DRIVE SUITE 160 WOODBURY MN 55125	Inv# 250611	PV 132754 001 00999	7/14/2025	250611	435.49		110480	OPUS 21 MANAGEMENT SOLUTIONS
					Summary Total	435.49			
					Payment Amount	435.49			
112421	PERRILL PERRILL 110 CHESHIRE LANE SUITE 105 MINNETONKA MN 55305		PV 132832 001 00999	7/1/2025	264600	200.00		112421	PERRILL
					Summary Total	200.00			
					Payment Amount	200.00			
100393	PRAIRIE RESTORATIONS INC PRAIRIE RESTORATIONS INC 31646 128TH STREET PRINCETON MN 55371		PV 132759 001 00999	7/16/2025	INV-015636	3,875.00		100393	PRAIRIE RESTORATION INC
					Summary Total	3,875.00			
			PV 132913 001 00999	7/25/2025	INV-015849	1,300.00			
					Summary Total	1,300.00			
					Payment Amount				

CITY OF RAMSEY
Create Payment Control Groups

Payment Group Control Number 4042
 Bank Account 999.1010 CASH IN BANK 00002224
 Version LOGIS004V
 Originator JMORRISON
 Payment Instrument T A/P ACH Payment
 Pay Through Date 8/13/2025

Payee		Stub	Document			Due	Invoice	Payment	Discount	Supplier		
Number	Name / Mailing Address	Message	Ty	Number	Itm	Co	Date	Number	Amount	Taken	Number	Name
									5,175.00			
113444	PRECISE		PV	132937	001	00999	7/18/2025	IN200-2006850	1,242.00		113444	PRECISE
	PRECISE								1,242.00			
	8633 EAGLE CREEK PKWY											
	SAVAGE MN 55378											
									1,242.00			
									1,242.00			
107978	PREMIER COMMERCIAL PROPERTIES INC	6701, 6745, 6781 Hwy 10 Prop	PV	132820	001	00999	7/18/2025	10266	600.00		107978	PREMIER COMMERCIAL PROPERTIES INC
	PREMIER COMMERCIAL PROPERTIES INC								600.00			
	299 COON RAPIDS BLVD NW #200											
	COON RAPIDS MN 55433											
									600.00			
									600.00			
121170	RIDGEWAY AND ASSOCIATES		PV	132981	001	00999	7/31/2025	3298	420.00		121170	RIDGEWAY AND ASSOCIATES
	RIDGEWAY AND ASSOCIATES								420.00			
	1030 COUNTY ROAD E WEST #140											
	SHOREVIEW MN 55126											
									420.00			
									420.00			
122114	ROBERTSON, ANSCHUTZ, SCHNEID & CRANE LLC		PV	132884	001	00999	7/18/2025	14431	26.00		122114	ROBERTSON, ANSCHUTZ, SCHNEID & CRANE LLC
	ROBERTSON, ANSCHUTZ, SCHNEID & CRANE LLC								26.00			
	6409 CONGRESS AVE STE 100											
	BOCA RATON FL 33487											
									26.00			
									26.00			

Payment Group Control Number 4042
 Bank Account 999.1010 CASH IN BANK 00002224
 Version LOGIS004V
 Originator JMORRISON
 Payment Instrument T A/P ACH Payment
 Pay Through Date 8/13/2025

Payee Number	Stub Message	Document Ty Number	Due Date	Invoice Number	Payment Amount	Discount Taken	Supplier Number	Supplier Name
					26.00			
121670	SAFE FAST	PV 132836 001 00999	7/11/2025	INV311239	183.60		121670	SAFE FAST
	SAFE FAST 2218 SEYMOUR RD EAU CLAIRE WI 54703				183.60			
					183.60			
100431	SAFETY KLEEN CORPORATION	PV 132941 001 00999	7/12/2025	97582355	413.41		100431	SAFETY KLEEN CORPORATION
	SAFETY KLEEN CORPORATION PO BOX 975201 DALLAS TX 75397-5201				413.41			
					413.41			
100469	STREICHER'S POLICE EQUIPMENT	PV 132757 001 00999	7/14/2025	11772521	156.94		100469	STREICHER'S POLICE EQUIPMENT
	STREICHER'S POLICE EQUIPMENT 10911 WEST HWY 55 MINNEAPOLIS MN 55441				156.94			
					156.94			
110313	SUMMIT FIRE PROTECTION	PV 132772 001 00999	7/17/2025	3392063	546.00		110313	SUMMIT FIRE PROTECTION
	SUMMIT FIRE PROTECTION P O BOX 851675 MINNEAPOLIS MN 55485-1675				546.00			
					546.00			

CITY OF RAMSEY
Create Payment Control Groups

Payment Group Control Number 4042
 Bank Account 999.1010 CASH IN BANK 00002224
 Version LOGIS004V
 Originator JMORRISON
 Payment Instrument T A/P ACH Payment
 Pay Through Date 8/13/2025

Payee Number	Name / Mailing Address	Stub Message	Document Ty	Number	Itm	Co	Due Date	Invoice Number	Payment Amount	Discount Taken	Supplier Number	Supplier Name	
Payment Amount									546.00				
100485	TIMESAVER OFF SITE SECRETARIAL INC		PV	132765	001	00999	7/14/2025	30736	305.63		100485	TIMESAVER OFF SITE SECRETARIAL INC	
				Summary Total					305.63				
	TIMESAVER OFF SITE SECRETARIAL INC 21021 KAROLINE COURT N FOREST LAKE MN 55025		PV	132766	001	00999	7/14/2025	30767	212.50				
				Summary Total					212.50				
			PV	132986	001	00999	7/31/2025	30798	254.13				
				Summary Total					254.13				
			PV	132987	001	00999	7/31/2025	30797	414.01				
				Summary Total					414.01				
			PV	132988	001	00999	7/31/2025	30858	212.50				
				Summary Total					212.50				
			PV	132989	001	00999	7/31/2025	30857	212.50				
				Summary Total					212.50				
			PV	132990	001	00999	7/31/2025	30856	172.00				
				Summary Total					172.00				
			Payment Amount							1,783.27			
103641	TRANSWEST TRUCKS ST MICHAEL		PV	133010	001	00999	7/31/2025	093P38051	281.20		103641	TRANSWEST TRUCKS S MICHAEL	
				Summary Total					281.20				
	TRANSWEST TRUCKS ST MICHAEL P O BOX 335 BRIGHTON CO 80601		Payment Amount							281.20			

Payment Group Control Number 4042
 Bank Account 999,1010 CASH IN BANK 00002224
 Version LOGIS004V
 Originator JMORRISON
 Payment Instrument T A/P ACH Payment
 Pay Through Date 8/13/2025

Payee Number Name / Mailing Address	Stub Message	Document Ty Number Itm Co	Due Date	Invoice Number	Payment Amount	Discount Taken	Supplier Number Name
106351 WATER LABORATORIES, INC		PV 132747 001 00999	7/14/2025	10552	780.00		106351 WATER LABORATORIES, INC
Summary Total					780.00		
Payment Amount					780.00		
111137 WRIGHT HENNEPIN COOPERATIVE ELECTRIC		PV 132998 001 00999	7/29/2025	150-1681-6340 AUG 2025	57.95		111137 WRIGHT HENNEPIN COOPERATIVE ELECTRI
Summary Total					57.95		
WRIGHT HENNEPIN COOPERATIVE ELECTRIC P O BOX 77027		PV 133014 001 00999	7/29/2025	150-1681-4280 AUG 2025	257.15		
Summary Total					257.15		
Payment Amount					315.10		
Total Amount to be Processed					341,288.72		
Total Number of Payments to be Processed					59		

Checks - 163,171.34
 ACH - 341,288.72
 Total A/P - 504,460.06

THIS PAGE LEFT BLANK INTENTIONALLY

Councilmember introduced the following resolution and moved for its adoption:

RESOLUTION #25-182

RESOLUTION APPROVING CASH DISBURSEMENTS MADE AND AUTHORIZING PAYMENT OF ACCOUNTS PAYABLE INVOICING RECEIVED DURING THE PERIOD OF JULY 17, 2025 THROUGH AUGUST 6, 2025

WHEREAS, the City of Ramsey Finance Department has made cash disbursements and received accounts payable invoicing during the period of July 17, 2025 through August 6, 2025 in the amount of \$2,012,843.39 and

WHEREAS, the City Council of the City of Ramsey is required to authorize payment for all disbursement transactions.

NOW THEREFORE, BE IT RESOLVED BY THE CITY COUNCIL OF THE CITY OF RAMSEY, ANOKA COUNTY, STATE OF MINNESOTA, as follows:

- 1) That the Ramsey City Council hereby approves the cash disbursements made and authorizes payment of the accounts payable invoices as detailed in the attached Bills List for the period July 17, 2025 through August 6, 2025 in the amount of \$2,012,843.39.

The motion for adoption of the foregoing resolution was duly seconded by Councilmember , and upon vote being taken thereon, the following voted in favor thereof:

Mayor Heineman
Councilmember
Councilmember
Councilmember
Councilmember
Councilmember
Councilmember

and the following voted against the same:

None

and the following abstained:

None

and the following were absent:

None

Whereupon said resolution was declared duly passed and adopted by the Ramsey City Council this the 12th day of August, 2025.

Mayor

ATTEST:

City Clerk

CC Regular Session

Meeting Date: 08/12/2025

Primary Strategic Plan Initiative: Create a positive image for residential neighborhoods, business districts and key corridors.

Title:

Adopt Resolution #25-178 Approving a Development Agreement for CCI Holdings 2, LLC (14047 Auzrite St. NW)

Purpose/Background:

The property owner of 14047 Azurite Street NW, CCI Holdings 2, LLC, is improving the building and property, including bringing many illegally-installed non-conforming site improvements into conformance with the Zoning Code. The building permit and associated site plan review is administrative in nature, though approval of the development agreement to provide site sureties guaranteeing the work is done according to plan, correctly, and in a timely manner, must be approved by the City Council. The proposed agreement is standard in form.

Notification:

None required.

Funding Source:

All costs of the improvements are the responsibility of the property owner.

Recommendation:

Staff recommends approval of the proposed development agreement.

Outcome/Action:

Motion to adopt Resolution #25-178 approving a development agreement for CCI Holdings 2, LLC.

Attachments

Resolution #25-178
Development Agreement
Site Plan

Form Review

Inbox	Reviewed By	Date
Brian Hagen	Brian Hagen	08/07/2025 03:49 PM
Form Started By: Todd Larson		Started On: 07/18/2025 04:08 PM
Final Approval Date: 08/07/2025		

Councilmember _____ introduced the following resolution and moved for its adoption:

RESOLUTION #25-178

**RESOLUTION APPROVING A DEVELOPMENT AGREEMENT FOR
CCI HOLDINGS 2, LLC**

WHEREAS, The City of Ramsey received an application from CCI Holdings 2, LLC (dba Clark Companies) (the “**Applicant**”), requesting approval of a building permit and administrative site plan review on the property legally described as follows:

Parcel 1

The South 200 feet of the North 250 feet of the West 220 feet of the East 880 feet of Lot 1, Auditors Subdivision No. 30, Anoka County, Minnesota;

together with

Parcel 2

The South 212.68 feet of the North 462.68 feet of the West 220 feet of the East 880 feet of Lot 1, Auditors Subdivision No. 30, Anoka County, Minnesota.

(the “**Subject Property**”).

WHEREAS, the **Applicant** is proposing to correct illegally-installed site improvements and bring the remaining non-conforming site improvements up to current Zoning Code standards on the **Subject Property**; and

WHEREAS, the proposed improvements are reviewed administratively through a building permit; and

WHEREAS, a Development Agreement is required to provide financial guaranty of site improvements for proposed developments; and

WHEREAS, the proposed Development Agreement conforms to City Code requirements; and

WHEREAS, the City Council reviewed the request at their meeting on August 12, 2025.

NOW THEREFORE, BE IT RESOLVED BY THIS CITY COUNCIL OF THE CITY OF RAMSEY, ANOKA COUNTY, STATE OF MINNESOTA, as follows:

- 1) That the Ramsey City Council hereby grants approval of the Development Agreement for CCI Holdings 2, LLC, on the **Subject Property** in accordance with relevant City Codes, subject to the following conditions:

- a. Final legal form approved by the City Attorney.
- b. That the **Applicant** enters into a Development Agreement with the City prior to commencing construction.
- c. That the Mayor and City Administrator are authorized to sign the Development Agreement.

The motion for adoption of the foregoing resolution was duly seconded by Councilmember _____, and upon vote being taken thereon, the following voted in favor thereof:

and the following voted against the same:

and the following abstained:

and the following were absent:

Whereupon said resolution was declared duly passed and adopted by the Ramsey City Council this the 12th day of August, 2025.

Mayor

ATTEST:

City Clerk

**CCI HOLDINGS 2, LLC
DEVELOPMENT AGREEMENT
14047 AZURITE STREET NW
CITY OF RAMSEY, ANOKA COUNTY, MINNESOTA**

This Agreement (hereinafter the “Agreement”) is dated as of this 12th day of August, 2025, and is by and between the City of Ramsey, a Minnesota municipal corporation (the “**CITY**”) and **CCI HOLDINGS 2, LLC**, a limited liability company under the laws of Minnesota, (the “**PERMITTEE**”).

Recitals

- A. The **PERMITTEE** is the fee title owner of land generally known as 14047 Azurite Street Northwest, Ramsey, MN 55303 and legally described as:

Parcel 1

The South 200 feet of the North 250 feet of the West 220 feet of the East 880 feet of Lot 1, Auditors Subdivision No. 30, Anoka County, Minnesota;

together with

Parcel 2

The South 212.68 feet of the North 462.68 feet of the West 220 feet of the East 880 feet of Lot 1, Auditors Subdivision No. 30, Anoka County, Minnesota.

(the “**Subject Property**”)

- B. That on April 17, 2025, the **CITY** received a Building Permit Application from Josh Clark on behalf of CCI Holdings 2, LLC (the “**PERMITTEE**”) requesting an Administrative Site Plan proposal to demise a legal non-conforming industrial building for warehousing uses on the **Subject Property**, and associated site improvements (cumulatively, the “**Project**”).
- C. That the **PERMITTEE** intends to bring various non-conforming site improvements into compliance with the Project.
- D. The **PERMITTEE** intends to cause the Required Improvements to the **Subject Property** to be constructed without financial participation by the **CITY**.

Agreement

**SECTION I
REQUIRED IMPROVEMENTS AND FINANCIAL RESPONSIBILITIES**

1. **City Code Compliance.** The CITY approves the site plan (the "Site Plan") conditioned on the PERMITTEE developing the **Subject Property** in accordance with the applicable provisions of City Code.
2. **Conformance with the Plans.** The **Subject Property** shall be developed in accordance with the final plans (the "**Plans**") prepared by Becklin & Whitney and dated June 30, 2025. The **Plans** remain subject to: (a) City Staff's review and approval of the **Plans** to, among other things, confirm that the revisions requested in the CITY's review have been made; and (b) such further revisions as the PERMITTEE may propose and the CITY approves. The **Plans** shall not be attached to this **Agreement**, but are in the CITY's files.
3. **Incorporation of All City Code Requirements.** That the recitals above and the applicable provisions of the City Charter, Subdivision Code, and Zoning Code of the CITY, as amended to date hereof, are incorporated herein by reference.
4. **State Building Code Compliance.** The structure(s) shall be constructed in accordance with the requirements of the Building Code.
5. **Fire Lanes.** Fire lanes shall be maintained on the **Subject Property**. The exact locations of these items on the **Subject Property** shall be as directed by the Fire Chief. The PERMITTEE herein agrees to post "No Parking" signs along driveways in accordance with City Code requirements and in conjunction with the instructions of the Fire Chief.
6. **Required On-Site Improvements.** The PERMITTEE shall construct and install the following site improvements on the **Subject Property** in accordance with the specifications and location as shown on the **Plans**. The Required Improvements and the allocated costs therefor are as follows:

Required Improvements	Cost	75% of Cost Release Amount
a. Site Grading	\$20,650.00	\$15,487.50
b. Parking Lot Construction	\$65,863.50	\$49,397.63
c. Erosion Control & Turf Restoration	\$7,392.50	\$5,544.37
TOTAL	\$93,906.00	\$70,429.50

("Required Improvements")

The PERMITTEE agrees to construct the **Required Improvements** according to the terms and conditions of this **Agreement**, in accordance with the **Plans**, and in compliance with Staff review comments.

7. **Required Improvements Completion Date.** The **Required Improvements** shall be completed within twelve (12) months from the date of Site Plan approval for the **Project**, subject to Unavoidable Delays. For the purposes of this Agreement, Unavoidable Delays means delays,

outside the control of the party claiming its occurrence, which are the result of strikes, other labor troubles, unusually severe or prolonged bad weather, acts of God, global pandemic, epidemic, fire or other casualty to the Project, litigation commenced by third parties which, by injunction or other similar judicial action or by the exercise of reasonable discretion, results in delays, or acts of any federal, state or local governmental unit other than the CITY.

8. **Required Improvements Financial Guaranty.** In order to ensure the installation of the **Required Improvements** in accordance with CITY specifications and in a timely manner, the **PERMITTEE** shall be required to deposit with the CITY a cash escrow or an irrevocable letter of credit, approved as to form by the CITY, in the amount of **Seventy Thousand Four Hundred Twenty-Nine Dollars and Fifty Cents (\$70,429.50)**, which is 75% of the CITY's estimated cost of the **Required Improvements** for the on-site improvements. Prior to the issuance of the building permit, the financial guaranty must be provided as required herein.

At the request of **PERMITTEE**, the CITY shall, not more frequently than once monthly, release that part of the Financial Guaranty for any completed portion of the **Required Improvements** in the amount set forth in Section 6 that have been accepted in writing by the CITY. Upon completion of the construction of all or any remaining of the **Required Improvements** and written approval by the CITY, the financial guaranty shall be returned to the **PERMITTEE**. The determination of completion of the construction of the **Required Improvements** shall be made by the CITY. In the event the **PERMITTEE** fails to construct and install the **Required Improvements** as required herein, the City Council may order the completion of the **Required Improvements** with CITY day labor and/or by letting contracts for said completion and draw upon the escrow for payment. Only the City Council shall have the authority to direct completion of the **Required Improvements** and withdraw from the escrow account. The **PERMITTEE** hereby grants permission and a license to the CITY and/or its contractors and assigns to enter upon the **Subject Property** for the purpose of completing the construction and installation of the **Required Improvements** in the event of the **PERMITTEE's** default.

9. **Site Inspection Fees.** The **PERMITTEE** shall be responsible for all site inspection costs incurred by the CITY related to the installation of **Required Improvements**. The **PERMITTEE** shall make a cash deposit into the appropriate escrow account at the CITY and the CITY shall have the authority to draw upon these funds for the purpose of compensating for inspection services. The amount of the deposit shall be equal to five percent (5%) of the estimated cost of the **Required Improvements**, which equates to **Four Thousand Six Hundred Ninety-Five Dollars and No Cents (\$4,695.00)** (5% x \$93,906.00). Upon completion of the **Required Improvements** to the satisfaction of the CITY, any surplus balance remaining in the CITY's escrow account shall be refunded to the **PERMITTEE**.

SECTION II PERMITS AND OCCUPANCY

10. Requirements for Building Permit.

- a. No building permit shall be issued until the **PERMITTEE** has: (a) installed a Class 5 driving surface to within 300 feet of the structure; (b) provided the CITY Building Official with a Certificate of Survey; (c) the financial guaranty described in Section I Paragraph 8 to the CITY; and (d) obtained all necessary permits from the Lower Rum River Watershed Management Organization and has provided a copy of such permit to the CITY, if applicable; and

- b. No occupancy permit shall be issued until the **PERMITTEE** has: (a) constructed vehicular access to the lot, including the installation of at least one layer of bituminous surfacing; and (b) constructed all utilities and storm water facilities this **Agreement** requires to serve the lot and such utilities and storm water facilities are in place, operational and accepted by the **CITY**.

SECTION III GENERAL

- 11. **Survey Monumentation.** The **PERMITTEE** must protect all lot corner stakes and survey monumentation at all lot corners.
- 12. **Preconstruction Meeting.** The **PERMITTEE** shall schedule and hold a pre-construction meeting with the **CITY** prior to commencing site work.
- 13. **Boulevard and Area Restoration.** The **PERMITTEE** shall be responsible for restoring all areas disturbed by the development grading operation in accordance with the approved erosion and sediment control plan. The **PERMITTEE** shall also be responsible for the cost of cleaning any soil, earth or debris from the wetlands within and adjacent to the **Subject Property** resulting from grading performed in the development of the land.
- 14. **Construction Site Maintenance.** The **PERMITTEE** shall adhere to all **CITY** ordinances relating to, but not limited to, dumping of garbage, site development, construction debris, open burning, etc.
- 15. **Construction, Hours and Entrance Signs.** The **CITY** restricts construction and delivery hours to Monday through Saturday 7:00 a.m. to 10:00 p.m. The **PERMITTEE** is required to provide a sign at each entrance point stating delivery and construction operation hours. Said signs are not to exceed eighty (80) square feet in size and must be clearly visible at all times during the construction period.
- 16. **Estimated Cost.** It is understood and agreed that cost amounts set forth in this **Agreement** as **Required Improvements**, unless specified as fixed amounts, are estimated. The **PERMITTEE** agrees to pay the entire cost of said improvements including interest, engineering and legal charges.
- 17. **Site Plan Approval Expenses.** The **PERMITTEE** agrees that it will pay to the **CITY** all **CITY** expenses incurred in the approval of the **Site Plan**, including, but not limited to administration expenses, engineering and legal fees. Said expenses shall be paid within fifteen (15) days of billing by the **CITY** and outstanding billings shall be paid prior to issuance of the building permit. Any expenses incurred after the release of the building permit shall also be paid within said fifteen (15) day billing period. Failure to pay the **CITY's** expenses within the fifteen (15) day billing period will permit the **CITY** to draw upon any of the escrows required by this contract for payment.
- 18. **Reimbursement to the City.** The **PERMITTEE** agrees to reimburse the **CITY** for all costs incurred by the **CITY** in defense or enforcement of this **Agreement**, or any portion thereof, including court costs and reasonable engineering and attorney's fees.
- 19. **Invalidity of Any Section.** If any portion, section, subsection, sentence, clause, paragraph or phrase of this **Agreement** is for any reason held to be invalid by a court of competent jurisdiction, such decision shall not affect or void any of the other provisions of this **Agreement**.

20. **Proof of Authority.** When the **PERMITTEE** is a corporation, the **CITY** requires proof of authority by the corporation to execute this **Agreement**. This proof of authority may be satisfied by providing the **CITY** with a certified copy of minutes of the corporate Board of Directors granting such authority.
21. **Violation of This Permit.** If the **PERMITTEE** fails to perform any of the terms of this **Agreement** in the manner required by the **CITY**, the **CITY** shall be entitled to recover, from the **PERMITTEE** or the issuer of **PERMITTEE** financial guarantee, the full amount of any and all financial guarantees. Breach of any of the terms of this **Agreement** by the **PERMITTEE** shall also be grounds for denial of Building Permit or issuance of Certificate of Occupancy.
22. **Certificate of Occupancy.** The term “Certificate of Occupancy” as used in this **Agreement** shall be defined as a document issued by the **CITY’s** Building Official, which authorizes the structure to be used for its intended purposes.
23. **Agreement Binding on Successors and Assigns.** The **PERMITTEE** agrees that this **Agreement** shall be binding upon its successors and assigns.
24. **Notices.** Required notices shall be in writing, and shall be either hand delivered to the Parties, its employees or agents, or mailed to them by certified or registered mail at the following address:

TO PERMITTEE:

CCI Holdings 2, LLC
Attn: Josh Clark
14346 191st Avenue NW
Elk River, MN 55330

TO THE CITY:

City of Ramsey
Attn: Community Development Director
7550 Sunwood Drive NW
Ramsey, MN 55303

[The rest of this page left intentionally blank]

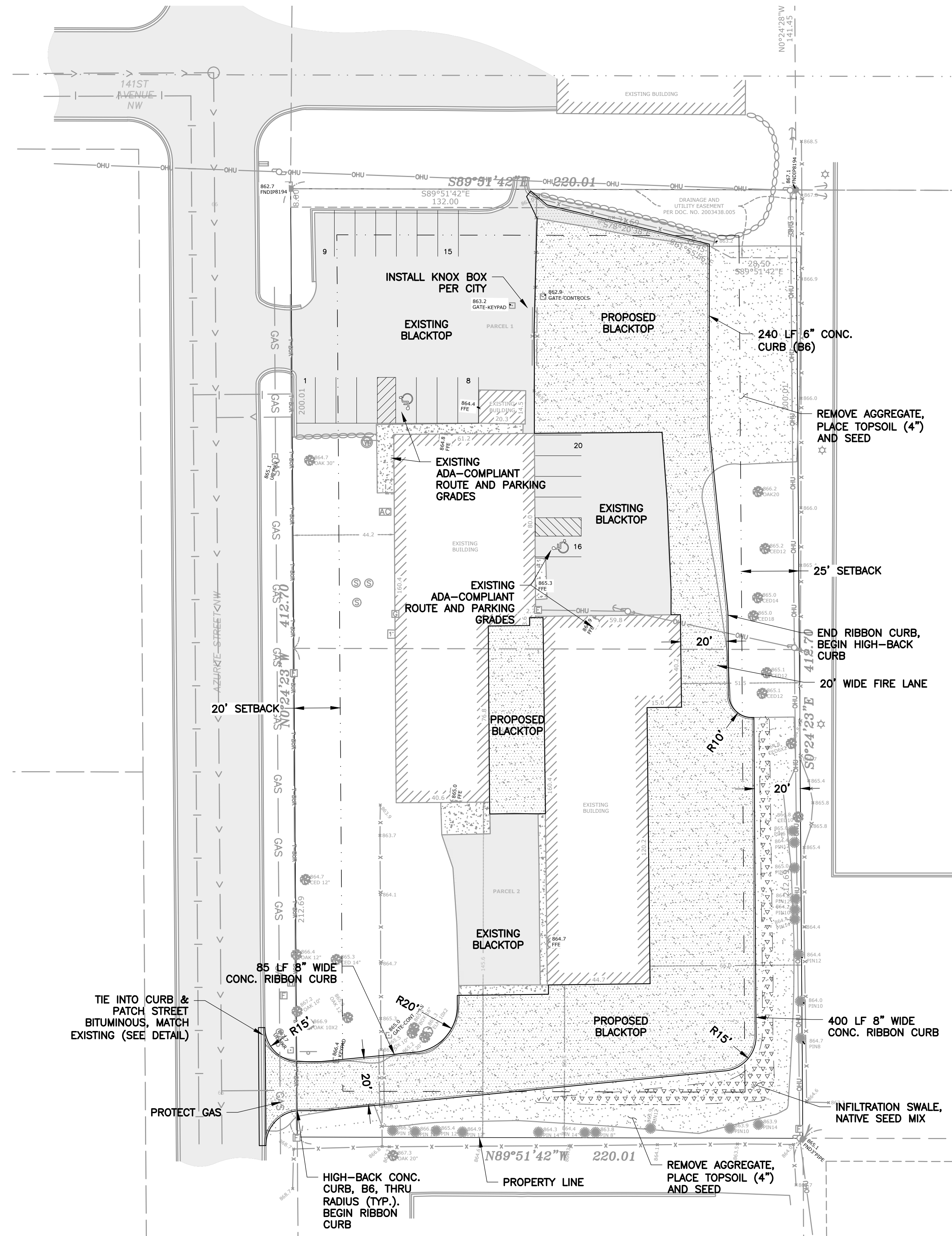

SITE DATA:

TOTAL PROPERTY AREA:	± 2.084 AC
PROPOSED HARD SURFACE:	± 5,6380 FT ² (1.294 AC)
PROPOSED HARD SURFACE %:	62%
MAXIMUM HARD SURFACE %:	80%
PROPOSED BUILDING AREA:	±16,000 FT ²
BUILDING FOOTPRINT %:	18%
MAXIMUM BUILDING FOOTPRINT:	50%
ZONING:	INDUSTRIAL, I-1
SETBACK, FRONT:	20 FT
SETBACK, SIDE:	20 FT
SETBACK, REAR:	25 FT
PARKING:	
OFFICE: 1500 SF @ 1 STALL/300 SF:	5 STALLS
INDUSTRIAL 14500 SF @ 1 STALL/1000 SF:	15 STALLS
TOTAL STALLS REQUIRED:	20 STALLS
ADA-ACCESSIBLE STALLS PROVIDED:	2 STALLS
STANDARD STALLS PROVIDED:	18 STALLS
TOTAL STALLS PROVIDED:	20 STALLS

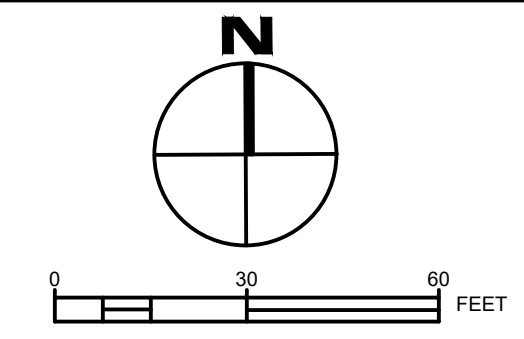

BENCHMARK
ANOKA COUNTY BENCHMARK 2090
ELEV.=885.937 (NAVD88)

LEGEND:

PROPERTY LINE	—
SETBACK	- - - - -
EASEMENT	- · - · -
CURB & GUTTER	▬▬▬▬▬
BITUMINOUS ASPHALT	▨▨▨▨▨
CONCRETE	▩▩▩▩▩
AGGREGATE	▧▧▧▧▧
STORMWATER BMP	▤▤▤▤▤

- GENERAL NOTES:**
- The subsurface utility location information in this plan is utility quality level D. This utility quality level was determined according to the guidelines of CI/ASCE 38-02, titled "Standard Guidelines for the Collection and Depiction of Existing Subsurface Utility Data." Engineer does not guarantee the accuracy of utility locations or that all existing utilities are shown; Contractor is responsible for locating utilities prior to digging.
 - Survey prepared by E.G. Rud & Sons, Inc. (4/17/2025)
 - All utilities were not located by survey; utilities shown in R.O.W. per as-built information.
 - Protect light poles and other existing utilities, signs, trees, etc. Relocation of any private utilities not directed on these plans shall be coordinated with the utility owner. Damaged items or property shall be repaired or replaced at Contractor's expense.
 - Parking lot dimensions are to face of curb unless noted otherwise.
 - Seed disturbed areas with commercial turf grass or prairie mix per preference.

- HOT MIX ASPHALT STREET PATCH:**
- Bituminous pavement shall be of type indicated in the details, meeting all material and installation requirements of Mn/DOT Specification Section 2360.
 - The bituminous surfacing shall be prepared, handled, and constructed per Mn/DOT 2360, with a maximum deviation of plus or minus 1/4 inch from the planned compacted thickness.
 - The bituminous material for tack coat shall be CSS-1, CSS-1h, CRS-1, or CRS-2 meeting requirements of Mn/DOT 2357.
 - When connecting to old bituminous pavement, a clean, straight, vertical edge will be provided by saw-cutting full depth through the existing pavement. New bituminous pavement shall match grade of existing pavement, with no noticeable difference at joint.
 - The contact surfaces of all fixed structures, the edge of the in-place mixture in all courses at transverse joints, and the wearing course at longitudinal joints shall be given a uniform coating of Liquid Asphalt or Emulsified Asphalt tackifier before placing the adjoining mixture. The bituminous material shall be applied at a rate of 0.05 Gal/SY and by methods that will ensure uniform coating and in no case shall the application be excessive. The contractor shall thoroughly clean all hard surfaces immediately before applying tack material.
 - Compaction of all street patch / driveway / parking lot bituminous asphalt mixtures shall be by the Ordinary Compaction Method (2360).

- CONCRETE CURBING & WALKS**
- ACI 330 R-08, ACI 330.1-03 Specifications and Mn/DOT Specification Section 2531 shall apply to ready-mixed concrete pavement materials, construction, curing, and quality control for curb and gutter construction and miscellaneous concrete work.
 - The concrete mix to be used shall be 3F52 for manual or slip form placement (2531).
 - Provide contraction and expansion jointing per Mn/DOT 2531; curb contraction joints shall be placed at even increments of 10 feet.
 - All concrete shall be coated with white pigmented curing compound immediately after finishing is complete in accordance with Mn/DOT 3754, meeting ASTM C309, Type 2.
 - Testing and inspection requirements per ACI-330.1-03. Contractor responsible for testing per ASTM C94. Concrete failing to meet strength shall be remedied as appropriate. Concrete tests for slump, air content, density, and temperature shall be performed at least once per day. All testing results shall be distributed to the Owner / Engineer for review.
 - Minimum 6" depth of Class 5 aggregate base shall be furnished under all curb. All base material shall be compacted to 100% Standard Proctor upon the prepared subgrade. Base course shall be moist, but not saturated during concrete placement. Apply water not less than 6 hours before placement; if base dries, sprinkle water to moisten to avoid pools.

Print Date: 6/30/2025 1:08 PM
 File Loc: C:\CIVIL\Methods, Inc\CM\ - Documents\17 - Projects\25646_Azurite Commercial\18 - Drawings AND SPECIFICATIONS\C201\Sheets\C201_Layout.dwg

CIVIL METHODS, INC.
 P.O. Box 28038
 St. Paul, MN 55128
 o:763.210.5713 | www.civilmethods.com

I HEREBY CERTIFY THAT THIS PLAN, SPECIFICATION, OR REPORT WAS PREPARED BY ME OR UNDER MY DIRECT SUPERVISION AND THAT I AM A DULY LICENSED PROFESSIONAL ENGINEER UNDER THE LAWS OF THE STATE OF MINNESOTA.

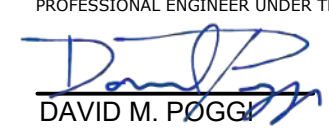
 DAVID M. POGGENDORF
 DATE: 06-30-2025
 LIC. NO.: 44573

DESIGNED: DMP
 DRAWN: DMP
 CHECKED: KEB

DATE / REVISION:
 05-21-2025 Permit Review Set
 06-10-2025 Removed sanitary connection
 06-30-2025 Revised per City comment

14047 AZURITE ST NW
 JOSH CLARK
 RAMSEY, MN

SITE LAYOUT & UTILITY CONNECTIONS

SHEET NO:
C201

CC Regular Session

Meeting Date: 08/12/2025

Primary Strategic Plan Initiative: Not Applicable

Title:

Adopt Resolution #25-179 To Amend Joint Powers Agreement With North Metro Mayors Association

Purpose/Background:

The City of Ramsey is a member of the Joint Powers Agreement (JPA) with the North Metro Mayors Association (NMMA). NMMA is a coalition of cities who work together to better the northern metro region through advocating on transportation improvements to presenting a common voice on legislative actions. The City of Crystal is seeking to join the NMMA, and per the by-laws, member cities must amend the JPA for this to occur. Member cities through the NMMA Board meeting collectively agree the addition of the City of Crystal will aid in the groups efforts.

Notification:

N/A

Recommendation:

Staff recommends approving the 2nd Amendment to the JPA for NMMA.

Outcome/Action:

Motion to adopt Resolution #25-179 to Amend Joint Powers Agreement with North Metro Mayors Association.

Attachments

Res# 25-179

2025 Amendment to NMMA JPA

Form Review

Inbox

Brian Hagen

Form Started By: Brian Hagen

Final Approval Date: 08/07/2025

Reviewed By

Brian Hagen

Date

08/07/2025 03:49 PM

Started On: 07/30/2025 12:03 PM

Councilmember _____ introduced the following resolution and moved for its adoption:

RESOLUTION #25-179

**RESOLUTION TO AMEND JOINT POWERS AGREEMENT WITH NORTHER
METRO MAYORS ASSOCIATION**

WHEREAS, the purpose of the Joint Powers Agreement of the North Metro Mayors Association (“JPA”) is to establish an organization to promote transportation and economic development projects and to assist in conducting government functions effectively and efficiently in the member communities of the northern metropolitan area; and

WHEREAS, the City of Ramsey is a member of the North Metro Mayors Association (“NMMA”); and

WHEREAS, the NMMA has determined that it is in the best interest of the public to amend the JPA to allow the City of Crystal as a member; and

WHEREAS, The Ramsey City Council deems that it is in the best interest to approve such changes.

NOW THEREFORE, BE IT RESOLVED BY THE CITY COUNCIL OF THE CITY OF RAMSEY, ANOKA COUNTY, STATE OF MINNESOTA, as follows:

- 1) That the Ramsey City Council hereby approves the second amended changes to the Joint Powers Agreement with the North Metro Mayors Association to allow membership of the City of Crystal.

The motion for adoption of the foregoing resolution was duly seconded by Councilmember _____, and upon vote being taken thereon, the following voted in favor thereof:

and the following voted against the same:

None

and the following abstained:

None

and the following were absent:

None

Whereupon said resolution was declared duly passed and adopted by the Ramsey City Council this

the 12th day of August, 2025.

Mayor

ATTEST:

City Clerk

**SECOND AMENDED
JOINT POWERS AGREEMENT
FOR A COALITION OF METROPOLITAN COMMUNITIES**

THIS AGREEMENT, made and entered into by and between the cities of Andover, Anoka, Brooklyn Center, Brooklyn Park, Champlin, Circle Pines, Coon Rapids, Dayton, Fridley, Mounds View, Maple Grove, New Brighton, New Hope, Ramsey, and Spring Lake Park, which cities are all of the current eligible members (hereinafter collectively referred to as the “Current Members”) of the North Metro Mayors Association, a Minnesota joint powers organization (hereinafter referred to as the “Coalition”).

WHEREAS, the Current Members determined in 2010 that it was in the best interest of the public to amend the joint powers agreement of the Coalition; and

WHEREAS, the Current Members determined in 2019 that it was in the best interest of the public to amend the Amended and Restated JPA of the Coalition.

WHEREAS, the city of Crystal is interested in becoming Members to the JPA and a majority of Members are in agreement to allow the new Member city.

WHEREAS, furthermore current Members determined it is in the best interest to amend the JPA as set forth below;

NOW, THEREFORE, by virtue of the powers granted by law and in consideration of the mutual covenants and agreements of the parties hereto, it is agreed as follows:

1. Definitions. All capitalized terms, not otherwise separately defined herein, shall have the meanings ascribed to them in the Joint Powers Agreement.
2. Addition of Crystal. As of the date hereof, the City of Crystal shall become a party to the Joint Powers Agreement and shall assume all the responsibilities and liabilities of the parties thereunder.
3. Full Force and Effect. Except as expressly amended herein, the terms and provision contained in the Joint Powers Agreement and its Amendments shall continue to govern the rights and obligations of the Cities, and the Joint Powers

[The remainder of this page intentionally left blank.]

CITY OF ANDOVER

By: _____

And by: _____

CITY OF ANOKA

By: _____

And by: _____

CITY OF BROOKLYN CENTER

By: _____

And by: _____

CITY OF BROOKLYN PARK

By: _____

And by: _____

CITY OF CHAMPLIN

By: _____

And by: _____

CITY OF CIRCLE PINES

By: _____

And by: _____

CITY OF COON RAPIDS

By: _____

And by: _____

CITY OF DAYTON

By: _____

And by: _____

CITY OF FRIDLEY

By: _____

And by: _____

CITY OF MOUNDS VIEW

By: _____

And by: _____

CITY OF MAPLE GROVE

By: _____

And by: _____

CITY OF NEW BRIGHTON

By: _____

And by: _____

CITY OF NEW HOPE

By: _____

And by: _____

CITY OF RAMSEY

By: _____

And by: _____

CITY OF SPRING LAKE PARK

By: _____

And by: _____

CITY OF CRYSTAL

By: _____

And by: _____

CC Regular Session**Meeting Date:** 08/12/2025**Primary Strategic Plan Initiative:** Create a positive image for residential neighborhoods, business districts and key corridors.**Title:**

Adopt Resolution #25-180 Approving a Development Agreement for CCI Holdings 3, LLC (14310 Sunfish Lake Blvd. NW).

Purpose/Background:

The property owner of 14310 Sunfish Lake Blvd. NW, CCI Holdings 3, LLC, is improving the building and property, including bringing many non-conforming site improvements into conformance with the Zoning Code and adding new site improvements. The building permit and associated site plan review are administrative in nature, though approval of the development agreement to provide site sureties guaranteeing the work is done according to plan, correctly, and in a timely manner, must be approved by the City Council. The proposed agreement is standard in form.

Notification:

None required.

Funding Source:

All costs of the improvements are the responsibility of the property owner.

Recommendation:

Staff recommends approval of the development agreement.

Outcome/Action:

Motion to adopt Resolution #25-180 approving a development agreement for CCI Holdings 3, LLC.

Attachments

Resolution #25-180
Development Agreement
Site Plan

Form Review

Inbox	Reviewed By	Date
Brian Hagen	Brian Hagen	08/07/2025 03:49 PM
Form Started By: Todd Larson		Started On: 07/31/2025 09:01 AM
Final Approval Date: 08/07/2025		

Councilmember _____ introduced the following resolution and moved for its adoption:

RESOLUTION #25-180

**RESOLUTION APPROVING A DEVELOPMENT AGREEMENT FOR
CCI HOLDINGS 3, LLC**

WHEREAS, The City of Ramsey received an application from CCI Holdings 3, LLC (dba Clark Companies) (the “**Applicant**”), requesting approval of a building permit and administrative site plan review on the property legally described as follows:

The South 250 feet of the North 750 feet of the East 871 feet as measured along the East and North lines of the North half of the Southeast quarter of Section 27, Township 32, Range 25, except road, subject to easement of record, Anoka County, Minnesota.

(the “**Subject Property**”).

WHEREAS, the **Applicant** is proposing to installed new site improvements and bring the remaining non-conforming site improvements up to current Zoning Code standards on the **Subject Property**; and

WHEREAS, the proposed improvements are reviewed administratively through a building permit; and

WHEREAS, a Development Agreement is required to provide financial guaranty of site improvements for proposed developments; and

WHEREAS, the proposed Development Agreement conforms to City Code requirements; and

WHEREAS, the City Council reviewed the request at their meeting on August 12, 2025.

NOW THEREFORE, BE IT RESOLVED BY THIS CITY COUNCIL OF THE CITY OF RAMSEY, ANOKA COUNTY, STATE OF MINNESOTA, as follows:

- 1) That the Ramsey City Council hereby grants approval of the Development Agreement for CCI Holdings 3, LLC, on the **Subject Property** in accordance with relevant City Codes, subject to the following conditions:
 - a. Final legal form approved by the City Attorney.
 - b. That the **Applicant** enters into a Development Agreement with the City prior to commencing construction.
 - c. That the Mayor and City Administrator are authorized to sign the Development

Agreement.

The motion for adoption of the foregoing resolution was duly seconded by Councilmember _____, and upon vote being taken thereon, the following voted in favor thereof:

and the following voted against the same:

and the following abstained:

and the following were absent:

Whereupon said resolution was declared duly passed and adopted by the Ramsey City Council this the 12th day of August, 2025.

Mayor

ATTEST:

City Clerk

**CCI HOLDINGS 3, LLC
DEVELOPMENT AGREEMENT
14310 SUNFISH LAKE BOULEVARD NW
CITY OF RAMSEY, ANOKA COUNTY, MINNESOTA**

This Agreement (hereinafter the “Agreement”) is dated as of this 12th day of August, 2025, and is by and between the City of Ramsey, a Minnesota municipal corporation (the “CITY”) and CCI HOLDINGS 3, LLC, a limited liability company under the laws of Minnesota, (the “PERMITTEE”).

Recitals

- A. The **PERMITTEE** is the fee title owner of land generally known as 14047 Azurite Street Northwest, Ramsey, MN 55303 and legally described as:

The South 250 feet of the North 750 feet of the East 871 feet as measured along the East and North lines of the North half of the Southeast quarter of Section 27, Township 32, Range 25, except road, subject to easement of record, Anoka County, Minnesota.

(the “**Subject Property**”)

- B. That on April 28, 2025, the **CITY** received a Building Permit Application from Josh Clark on behalf of CCI Holdings 3, LLC (the “**PERMITTEE**”) requesting an Administrative Site Plan proposal to demise a legal non-conforming industrial building for warehousing uses on the **Subject Property**, and associated site improvements (cumulatively, the “**Project**”).
- C. That the **PERMITTEE** intends to bring various non-conforming site improvements into compliance with the Project.
- D. The **PERMITTEE** intends to cause the Required Improvements to the **Subject Property** to be constructed without financial participation by the **CITY**.

Agreement

**SECTION I
REQUIRED IMPROVEMENTS AND FINANCIAL RESPONSIBILITIES**

1. **City Code Compliance.** The CITY approves the site plan (the "Site Plan") conditioned on the PERMITTEE developing the Subject Property in accordance with the applicable provisions of City Code.
2. **Conformance with the Plans.** The Subject Property shall be developed in accordance with the final plans (the "Plans") prepared by Becklin & Whitney and dated July 25, 2025. The Plans remain subject to: (a) City Staff's review and approval of the Plans to, among other things, confirm that the revisions requested in the CITY's review have been made; and (b) such further revisions as the PERMITTEE may propose and the CITY approves. The Plans shall not be attached to this Agreement, but are in the CITY's files.
3. **Incorporation of All City Code Requirements.** That the recitals above and the applicable provisions of the City Charter, Subdivision Code, and Zoning Code of the CITY, as amended to date hereof, are incorporated herein by reference.
4. **State Building Code Compliance.** The structure(s) shall be constructed in accordance with the requirements of the Building Code.
5. **Fire Lanes.** Fire lanes shall be maintained on the Subject Property. The exact locations of these items on the Subject Property shall be as directed by the Fire Chief. The PERMITTEE herein agrees to post "No Parking" signs along driveways in accordance with City Code requirements and in conjunction with the instructions of the Fire Chief.
6. **Required On-Site Improvements.** The PERMITTEE shall construct and install the following site improvements on the Subject Property in accordance with the specifications and location as shown on the Plans. The Required Improvements and the allocated costs therefor are as follows:

Required Improvements	Cost	75% of Cost Release Amount
a. Site Grading	\$14,750.00	\$11,062.50
b. Parking Lot Construction	\$57,753.50	\$43,315.13
c. Erosion Control & Turf Restoration	\$7,245.00	\$5,433.75
TOTAL	\$79,748.50	\$59,811.38

("Required Improvements")

The PERMITTEE agrees to construct the Required Improvements according to the terms and conditions of this Agreement, in accordance with the Plans, and in compliance with Staff review comments.

7. **Required Improvements Completion Date.** The Required Improvements shall be completed within twelve (12) months from the date of Site Plan approval for the Project, subject to Unavoidable Delays. For the purposes of this Agreement, Unavoidable Delays means delays, outside the control of the party claiming its occurrence, which are the result of strikes, other labor troubles, unusually severe or prolonged bad weather, acts of God, global pandemic, epidemic, fire or other casualty to the Project, litigation commenced by third parties which, by injunction or other similar judicial action or by the exercise of reasonable discretion, results in delays, or acts of any federal, state or local governmental unit other than the CITY.

8. **Required Improvements Financial Guaranty.** In order to ensure the installation of the **Required Improvements** in accordance with **CITY** specifications and in a timely manner, the **PERMITTEE** shall be required to deposit with the **CITY** a cash escrow or an irrevocable letter of credit, approved as to form by the **CITY**, in the amount of **Fifty Nine Thousand Eight Hundred Eleven Dollars and Thirty-Eight Cents (\$59,811.38)**, which is 75% of the **CITY**'s estimated cost of the **Required Improvements** for the on-site improvements. Prior to the issuance of the building permit, the financial guaranty must be provided as required herein.

At the request of **PERMITTEE**, the **CITY** shall, not more frequently than once monthly, release that part of the Financial Guaranty for any completed portion of the **Required Improvements** in the amount set forth in Section 6 that have been accepted in writing by the **CITY**. Upon completion of the construction of all or any remaining of the **Required Improvements** and written approval by the **CITY**, the financial guaranty shall be returned to the **PERMITTEE**. The determination of completion of the construction of the **Required Improvements** shall be made by the **CITY**. In the event the **PERMITTEE** fails to construct and install the **Required Improvements** as required herein, the City Council may order the completion of the **Required Improvements** with **CITY** day labor and/or by letting contracts for said completion and draw upon the escrow for payment. Only the City Council shall have the authority to direct completion of the **Required Improvements** and withdraw from the escrow account. The **PERMITTEE** hereby grants permission and a license to the **CITY** and/or its contractors and assigns to enter upon the **Subject Property** for the purpose of completing the construction and installation of the **Required Improvements** in the event of the **PERMITTEE**'s default.

9. **Site Inspection Fees.** The **PERMITTEE** shall be responsible for all site inspection costs incurred by the **CITY** related to the installation of **Required Improvements**. The **PERMITTEE** shall make a cash deposit into the appropriate escrow account at the **CITY** and the **CITY** shall have the authority to draw upon these funds for the purpose of compensating for inspection services. The amount of the deposit shall be equal to five percent (5%) of the estimated cost of the **Required Improvements**, which equates to **Three Thousand Nine Hundred Eighty-Seven Dollars and Forty-Three Cents (\$3,987.43)** (5% x \$79,748.50). Upon completion of the **Required Improvements** to the satisfaction of the **CITY**, any surplus balance remaining in the **CITY**'s escrow account shall be refunded to the **PERMITTEE**.

SECTION II PERMITS AND OCCUPANCY

10. **Requirements for Building Permit.**

- a. No building permit shall be issued until the **PERMITTEE** has: (a) installed a Class 5 driving surface to within 300 feet of the structure; (b) provided the **CITY** Building Official with a Certificate of Survey; (c) the financial guaranty described in Section I Paragraph 8 to the **CITY**; and (d) obtained all necessary permits from the Lower Rum River Watershed Management Organization and has provided a copy of such permit to the **CITY**, if applicable; and
- b. No occupancy permit shall be issued until the **PERMITTEE** has: (a) constructed vehicular access to the lot, including the installation of at least one layer of bituminous surfacing; and (b) constructed all utilities and storm water facilities this **Agreement** requires to serve the lot and such utilities and storm water facilities are in place, operational and accepted by the **CITY**.

SECTION III

GENERAL

11. **Survey Monumentation.** The **PERMITTEE** must protect all lot corner stakes and survey monumentation at all lot corners.
12. **Preconstruction Meeting.** The **PERMITTEE** shall schedule and hold a pre-construction meeting with the **CITY** prior to commencing site work.
13. **Boulevard and Area Restoration.** The **PERMITTEE** shall be responsible for restoring all areas disturbed by the development grading operation in accordance with the approved erosion and sediment control plan. The **PERMITTEE** shall also be responsible for the cost of cleaning any soil, earth or debris from the wetlands within and adjacent to the **Subject Property** resulting from grading performed in the development of the land.
14. **Construction Site Maintenance.** The **PERMITTEE** shall adhere to all **CITY** ordinances relating to, but not limited to, dumping of garbage, site development, construction debris, open burning, etc.
15. **Construction, Hours and Entrance Signs.** The **CITY** restricts construction and delivery hours to Monday through Saturday 7:00 a.m. to 10:00 p.m. The **PERMITTEE** is required to provide a sign at each entrance point stating delivery and construction operation hours. Said signs are not to exceed eighty (80) square feet in size and must be clearly visible at all times during the construction period.
16. **Estimated Cost.** It is understood and agreed that cost amounts set forth in this **Agreement** as **Required Improvements**, unless specified as fixed amounts, are estimated. The **PERMITTEE** agrees to pay the entire cost of said improvements including interest, engineering and legal charges.
17. **Site Plan Approval Expenses.** The **PERMITTEE** agrees that it will pay to the **CITY** all **CITY** expenses incurred in the approval of the **Site Plan**, including, but not limited to administration expenses, engineering and legal fees. Said expenses shall be paid within fifteen (15) days of billing by the **CITY** and outstanding billings shall be paid prior to issuance of the building permit. Any expenses incurred after the release of the building permit shall also be paid within said fifteen (15) day billing period. Failure to pay the **CITY's** expenses within the fifteen (15) day billing period will permit the **CITY** to draw upon any of the escrows required by this contract for payment.
18. **Reimbursement to the City.** The **PERMITTEE** agrees to reimburse the **CITY** for all costs incurred by the **CITY** in defense or enforcement of this **Agreement**, or any portion thereof, including court costs and reasonable engineering and attorney's fees.
19. **Invalidity of Any Section.** If any portion, section, subsection, sentence, clause, paragraph or phrase of this **Agreement** is for any reason held to be invalid by a court of competent jurisdiction, such decision shall not affect or void any of the other provisions of this **Agreement**.
20. **Proof of Authority.** When the **PERMITTEE** is a corporation, the **CITY** requires proof of authority by the corporation to execute this **Agreement**. This proof of authority may be satisfied by providing the **CITY** with a certified copy of minutes of the corporate Board of Directors granting such authority.
21. **Violation of This Permit.** If the **PERMITTEE** fails to perform any of the terms of this **Agreement** in the manner required by the **CITY**, the **CITY** shall be entitled to recover, from the

PERMITTEE or the issuer of **PERMITTEE** financial guarantee, the full amount of any and all financial guarantees. Breach of any of the terms of this **Agreement** by the **PERMITTEE** shall also be grounds for denial of Building Permit or issuance of Certificate of Occupancy.

22. **Certificate of Occupancy.** The term “Certificate of Occupancy” as used in this **Agreement** shall be defined as a document issued by the **CITY’s** Building Official, which authorizes the structure to be used for its intended purposes.

23. **Agreement Binding on Successors and Assigns.** The **PERMITTEE** agrees that this **Agreement** shall be binding upon its successors and assigns.

24. **Notices.** Required notices shall be in writing, and shall be either hand delivered to the Parties, its employees or agents, or mailed to them by certified or registered mail at the following address:

TO PERMITTEE:

CCI Holdings 3, LLC
Attn: Josh Clark
14346 191st Avenue NW
Elk River, MN 55330

TO THE CITY:

City of Ramsey
Attn: Community Development Director
7550 Sunwood Drive NW
Ramsey, MN 55303

[The rest of this page left intentionally blank]

THE PERMITTEE:

CCI Holdings 3, LLC

By: _____
Josh Clark
Its: Owner/President

STATE OF MINNESOTA)
) ss.
COUNTY OF _____)

The foregoing instrument was acknowledged before me this _____ day of _____, 2025, by Josh Clark, the Owner/President of CCI Holdings 3, LLC, a Minnesota limited liability company, on behalf of the company.

Notary Public

GENERAL NOTES:

- The subsurface utility location information in this plan is utility quality level D. This utility quality level was determined according to the guidelines of CI/ASCE 38-02, titled "Standard Guidelines for the Collection and Depiction of Existing Subsurface Utility Data." Engineer does not guarantee the accuracy of utility locations or that all existing utilities are shown; Contractor is responsible for locating utilities prior to digging.
- Survey prepared by E.G. Rud & Sons, Inc.
- Confirm concrete stoop and drive locations and dimensions with architectural and structural plans.
- Protect light poles and other existing utilities, signs, trees, etc. Relocation of any private utilities not directed on these plans shall be coordinated with the utility owner. Damaged items or property shall be repaired or replaced at Contractor's expense.
- Parking lot dimensions are to face of curb unless noted otherwise.
- Seed disturbed areas with commercial turf grass or prairie mix per preference.

HOT MIX ASPHALT:

- Bituminous pavement shall be of type indicated in the details, meeting all material and installation requirements of Mn/DOT Specification Section 2360.
- The bituminous surfacing shall be prepared, handled, and constructed per Mn/DOT 2360, with a maximum deviation of plus or minus 1/4 inch from the planned compacted thickness.
- The bituminous material for tack coat shall be CSS-1, CSS-1h, CRS-1, or CRS-2 meeting requirements of Mn/DOT 2357.
- When connecting to old bituminous pavement, a clean, straight, vertical edge will be provided by saw-cutting full depth through the existing pavement. New bituminous pavement shall match grade of existing pavement, with no noticeable difference at joint.
- The contact surfaces of all fixed structures, the edge of the in-place mixture in all courses at transverse joints, and the wearing course at longitudinal joints shall be given a uniform coating of Liquid Asphalt or Emulsified Asphalt tackifier before placing the adjoining mixture. The bituminous material shall be applied at a rate of 0.05 Gal/SY and by methods that will ensure uniform coating and in no case shall the application be excessive. The contractor shall thoroughly clean all hard surfaces immediately before applying tack material.
- Compaction of all street patch / driveway / parking lot bituminous asphalt mixtures shall be by the Ordinary Compaction Method (2360).

CONCRETE CURBING & WALKS

- ACI 330 R-08, ACI 330.1-03 Specifications and Mn/DOT Specification Section 2461, 2521 and 2531 shall apply to ready-mixed concrete pavement materials, construction, curing, and quality control for concrete pavements, curb and gutter construction and miscellaneous concrete work.
- The concrete mix to be used shall be 3F52 for manual or slip form placement (2531).
- Provide contraction and expansion jointing per Mn/DOT 2531; curb contraction joints shall be placed at even increments of 10 feet.
- All concrete shall be coated with white pigmented curing compound immediately after finishing is complete in accordance with Mn/DOT 3754, meeting ASTM C309, Type 2.
- Testing and inspection requirements per ACI-330.1-03. Contractor responsible for testing per ASTM C94. Concrete failing to meet strength shall be remedied as appropriate. Concrete tests for slump, air content, density, and temperature shall be performed at least once per day. All testing results shall be distributed to the Owner / Engineer for review.
- Minimum 6" depth of Class 5 aggregate base shall be furnished under all curb. All base material shall be compacted to 100% Standard Proctor upon the prepared subgrade.
- Base course shall be moist, but not saturated during concrete placement. Apply water not less than 6 hours before placement; if base dries, sprinkle water to moisten to avoid pools.

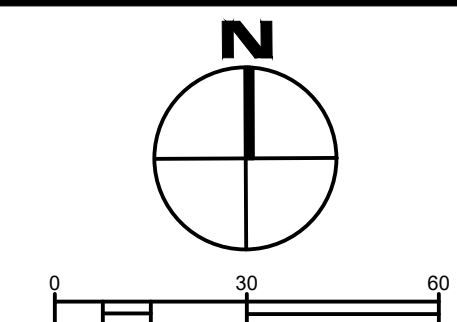

BENCHMARK
MNDOT BENCHMARK HYATT MNDT
ELEV.=897.001 (NAVD88)

LEGEND:

- PROPERTY LINE ———
- SETBACK - - - - -
- EASEMENT - - - - -
- CURB & GUTTER ———
- BITUMINOUS ASPHALT [Pattern]
- CONCRETE [Pattern]
- AGGREGATE [Pattern]

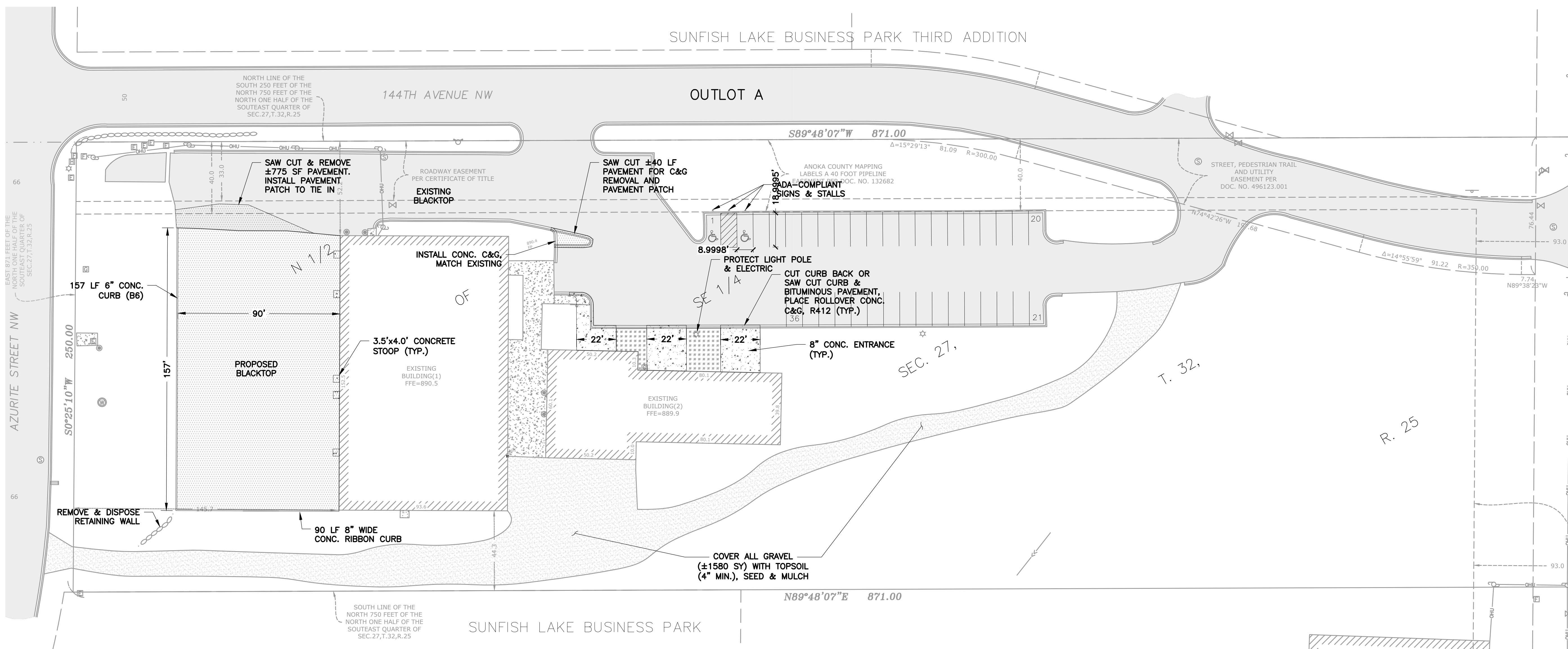

Print Date: 7/25/2025 10:16 AM
 File Loc: C:\CIVIL\Methods, Inc\CDM\ - Documents\17 - Projects\Sunfish Lake Blvd\06 - Drawings AND SPECIFICATIONS\CD\Sheets\01 - Layout.dwg

CIVIL METHODS, INC.
 P.O. Box 28038
 St. Paul, MN 55128
 o:763.210.5713 | www.civilmethods.com

I HEREBY CERTIFY THAT THIS PLAN, SPECIFICATION, OR REPORT WAS PREPARED BY ME OR UNDER MY DIRECT SUPERVISION AND THAT I AM A DULY LICENSED PROFESSIONAL ENGINEER UNDER THE LAWS OF THE STATE OF MINNESOTA.

 DAVID M. POGGENDORF
 DATE: 07-25-2025
 LIC. NO.: 44573

DESIGNED: DMP
 DRAWN: DMP
 CHECKED: KEB

DATE / REVISION:
 06-17-2025 Permit Review Set. NOT FOR CONSTRUCTION
 07-25-2025 Revised per City comments.

14310 SUNFISH LAKE BLVD
 JOSH CLARK
 RAMSEY, MN

LAYOUT



SHEET NO:
 01
 04

CC Regular Session

Meeting Date: 08/12/2025

Primary Strategic Plan Initiative: Address infrastructure needs.

Title:

Adopt Resolution No. 25-184 Accepting Quotes and Awarding Contract for Maintenance Project #25-60, Pumphouse No. 1 Roof Replacement

Purpose/Background:

Purpose:

The purpose of this case is to adopt Resolution #25-184 accepting quotes and awarding a construction contract for Maintenance Project #25-60, Pumphouse No. 1 Roof Replacement.

Background:

The 2025 – 2034 Capital Improvement Program includes proposed project #25-WTR-001, Pump House #1 Roof Replacement, proposed for construction in 2025 at an estimated cost of \$42,500.

City Pumphouse #1 is a 20’ by 30’ brick and mortar building that houses municipal well #1 plus all the chemical feed and SCADA controls. This structure has a flat concrete precast roof and a cedar shake Mansard exterior that utilizes a rubber membrane and rock ballast to drain water to the south side of the structure.

Over the last 40 years, the tiered Styrofoam underlayment designed to drain the water south has deteriorated and will not drain the roof water, thus holding several inches of water after rain and snow melt events. Several leaks have developed internal to the structure. The soffits, roof molding and cedar shakes are in disrepair and must be torn off and replaced.

Three (3) quotes were solicited and two (2) quotes were received as follows;

Contractor	Total Quote
MD Heiderscheid Your House Doctor	\$37,525.00
All Elements, Inc.	\$60,807.00
<i>Engineer’s Estimate</i>	<i>\$42,500.00</i>

The lowest responsible quote in the amount of \$37,525.00 was received from MD Heiderscheid Your House Doctor. Costs for this upgrade be paid from water enterprise funds.

Notification:

Notifications are not required for this case.

Time Frame/Observations/Alternatives:

Adopt Resolution #25-184 accepting quotes and awarding a construction contract for Maintenance Project #25-60, Pumphouse No. 1 Roof Replacement, to MD Heiderscheid Your House Doctor in the amount of \$37,525.00.

Funding Source:

All costs for this work will be paid from water enterprise funds.

Recommendation:

Staff recommends adopting Resolution #25-184.

Outcome/Action:

Adopt Resolution #25-184 accepting quotes and awarding a construction contract for Maintenance Project #25-60, Pumphouse No. 1 Roof Replacement, to MD Heiderscheid Your House Doctor in the amount of \$37,525.00.

Attachments

CIP Project 25-WTR-001
Resolution 25-184

Form Review

Inbox

Brian Hagen

Form Started By: Bruce Westby

Final Approval Date: 08/07/2025

Reviewed By

Brian Hagen

Date

08/07/2025 03:49 PM

Started On: 08/05/2025 08:25 AM

Capital Improvement Plan

Ramsey, MN

Project # 25-WTR-001
Project Name Pump House #1 Roof Replacement

Total Project Cost	\$42,500	Department	Water Utility
Type	Improvement	Category	Water Utility Improvement
Priority	1-Existing Obligation (High)	Status	Active
Useful Life	20 years		

Description

Pump House #1: Replace flat/rubber roof, tear off old cedar shake fascia and replace with metal fascia, new metal flashing and gutter repairs.

Justification

Pump House #1's roof is about 20 years old. Currently water is leaking into the chlorine room as well as into the wooden soffit area and rotting out the wooden soffit and fascia. We plan to replace the old rubber roof, wood soffit and cedar shake fascia with metal. There will be less maintenance and repairs with metal.

Expenditures	2025	2026	2027	2028	2029	2030	2031	2032	2033	2034	Total
Improvements Other than Building Cost	42,500	0	0	0	0	0	0	0	0	0	42,500
Total	42,500	0	0	0	0	0	0	0	0	0	42,500

Funding Sources	2025	2026	2027	2028	2029	2030	2031	2032	2033	2034	Total
Water Utility Fund	42,500	0	0	0	0	0	0	0	0	0	42,500
Total	42,500	0	0	0	0	0	0	0	0	0	42,500

Councilmember _____ introduced the following resolution and moved for its adoption:

RESOLUTION #25-184

RESOLUTION ACCEPTING QUOTES AND AWARDING CONTRACT FOR MAINTENANCE PROJECT #25-60, PUMPHOUSE NO. 1 ROOF REPLACEMENT

WHEREAS, the City of Ramsey 2025 – 2034 Capital Improvement Program includes proposed project #25-WTR-001, Pump House #1 Roof Replacement, proposed for construction in 2025, at an estimated cost of \$42,500; and

WHEREAS, requests for quotes were solicited from multiple contractors known to responsibly provide such services; and

WHEREAS, two (2) quotes were received as follows; and

Contractor	Total Quote
MD Heiderscheid Your House Doctor	\$37,525.00
All Elements, Inc.	\$60,807.00
<i>Engineer's Estimate</i>	<i>\$42,500.00</i>

WHEREAS, MD Heiderscheid Your House Doctor provided the lowest responsible quote in the amount of \$37,525.00 and their quote shall be and hereby is accepted.

NOW THEREFORE, BE IT RESOLVED BY THE CITY COUNCIL OF THE CITY OF RAMSEY, ANOKA COUNTY, STATE OF MINNESOTA:

- 1) The City Administrator is hereby authorized and directed to enter into a contract with said proposer for the construction of said improvements for and on behalf of the City of Ramsey.

The motion for the adoption of the foregoing resolution was duly seconded by Councilmember _____, and upon vote being taken thereon, the following voted in favor thereof:

and the following voted against the same:

and the following abstained:

and the following were absent:

Whereupon said resolution was declared duly passed and adopted by the Ramsey City Council this the 12th day of August, 2025.

Mayor

ATTEST:

City Clerk

CC Regular Session**Meeting Date:** 08/12/2025**Primary Strategic Plan Initiative:** Address infrastructure needs.**Title:**

Adopt Resolution #25-185 Supporting State Highway 47/St. Francis Boulevard Improvements

Purpose/Background:

In 2023 a fatal accident occurred on State Hwy 47 just north of Alpine Dr. NW. The family of the deceased have advocated to MnDOT for, at a minimum, additional signage restricting drivers from conducting u-turns on the highway immediately following a center median where the accident occurred. The family is requesting the City of Ramsey support their requests to MnDOT in signage improvements. The attached letter of support and accompanying resolution express such support.

Time Frame/Observations/Alternatives:

The letter of support and resolution were drafted by the deceased family's attorney and reviewed by City Attorney Knaak. City Attorney Knaak has provided his legal review for approval. Mr. Knaak will be available to answer any questions regarding the City's responsibilities in supporting this request.

Recommendation:

Staff recommends supporting this request in an effort to advocate for safer roadways.

Outcome/Action:

Motion to adopt Resolution #25-185 and approve the accompanying letter of support for State Highway 47/St. Francis Boulevard improvements.

Attachments

Res. #25-185

Res #25-185 Letter of Support

Form Review**Inbox**

Brian Hagen

Form Started By: Brian Hagen

Final Approval Date: 08/07/2025

Reviewed By

Brian Hagen

Date

08/07/2025 03:50 PM

Started On: 08/07/2025 03:38 PM

Councilmember introduced the following resolution and moved for its adoption:

RESOLUTION #25-185

RESOLUTION SUPPORTING STATE HIGHWAY 47/ST. FRANCIS BOULEVARD IMPROVEMENTS

WHEREAS, a portion of State Highway 47/St. Francis Boulevard passes through the City of Ramsey (the “City”); and

WHEREAS, that road is a state highway under the maintenance jurisdiction of the Minnesota Department of Transportation; and

WHEREAS, a fatal accident occurred on that road on May 27, 2023, near the end of the dividing median on the north side of the intersection of Highway 47 with Alpine Boulevard involving a vehicle making a U-Turn at that location; and

WHEREAS, based on the investigation reports of the City’s responding police officer and the crash reconstruction report of the Minnesota State Patrol, the U-turn was the primary factor causing that accident; and

WHEREAS, the family of the deceased, who are residents of the City, have requested the City to issue a statement of support for certain safety improvements on that road; and

WHEREAS, the City strives to support and improve the safety of all of its residents and visitors; and

WHEREAS, the safety improvements requested by the family are reasonable and likely to prevent or warn away drivers from making such dangerous maneuvers;

NOW THEREFORE, BE IT RESOLVED BY THE CITY COUNCIL OF THE CITY OF RAMSEY, ANOKA COUNTY, STATE OF MINNESOTA, as follows:

1. The City supports roadway and signage improvements that are reasonable and likely to improve the safety of drivers within the City of Ramsey.
2. City Staff are directed to issue a letter of support for the requested safety improvements. The Mayor and Council may add their supporting signatures to the letter as they feel so moved to do.

The motion for adoption of the foregoing resolution was duly seconded by Councilmember , and upon vote being taken thereon, the following voted in favor thereof:

Mayor Heineman
Councilmember

Councilmember
Councilmember
Councilmember
Councilmember
Councilmember

and the following voted against the same:

None

and the following abstained:

None

and the following were absent:

None

Whereupon said resolution was declared duly passed and adopted by the Ramsey City Council this the 12th day of August, 2025.

Mayor

ATTEST:

City Clerk

MnDOT Office of Traffic Engineering
Attn: Eric Peterson, P.E., Metro District Signing Engineer
1500 W. Co. Rd. B-2
Roseville, Mn. 55113

RE: Citizen Request for Signage and Safety Improvements – Highway 47

Dear Mr. Peterson,

The City has become aware of a dangerous traffic condition located on Highway 47/St. Francis Boulevard within the City's boundaries and under MnDOT's administration as a State highway. The City is also aware of a petition by the relatives of the late Mr. Timothy Vlasjuk to MnDOT for the installation of additional safety improvement features at that location. The City has an interest in protecting and improving the safety of all drivers using roads within the City, especially on roads frequently used by the City's residents and visitors. After reviewing the situation thoroughly, the City makes this formal statement of support for the Vlasjuk Family's request.

The City's staff, including its police officers, are aware of the layout of the road at this location and the City has also reviewed the Minnesota State Patrol reconstruction report of the accident which took Mr. Vlasjuk's life. At this location, a dividing median ends between two driveways adjoining the northbound lane, which are used by commercial operations including a truck rental facility. This site is also near to the intersection of Highway 47 and Alpine Drive. The nearest place to make a safe and legal turn from the northbound lane is nearly out of sight from the commercial driveways and the end of the median. It is evident to the City that drivers proceeding northbound on that road, especially if they are entering the road from the adjacent commercial driveways at Ken's Repair and Sales, Inc. property and the U-Haul rental lot associated with it, are likely to make a U-Turn at that location or make a left turn out of the northern driveway at that business.

It is critically important that additional measures be implemented to mitigate this situation and prevent or warn drivers away from making these dangerous maneuvers at this location. The Vlasjuks have requested that MnDOT install a "No U-Turns" sign among other improvements. At minimum, a "No U-Turns" sign will at least remind drivers who might be unfamiliar with this area to continue on and find a safe place to turn. There are already sign posts at the end of the median that would present an ideal location to mount a sign facing the northbound traffic. The Vlasjuk's proposals have the support of the City of Ramsey and its Council, and we urge MnDOT to carefully and consider the benefits of additional preventive measures.

One life is already too many to lose from preventable accidents.

Sincerely,

Ryan Heineman, Mayor

Brian Hagen, City Administrator

CC Regular Session**Meeting Date:** 08/12/2025**Primary Strategic Plan Initiative:** Address infrastructure needs.**Title:**

Adopt Resolution #25-176 Accepting Bids and Awarding Contract for 2025 Pavement Skim Patching Project, Maintenance Project #25-56

Purpose/Background:**Purpose:**

The purpose of this case is to adopt Resolution #25-176 accepting bids and awarding a construction contract for 2025 Pavement Skim Patching, Maintenance Project #25-56.

Background:

In 2023, the number of public streets with numerous deep potholes and surface stripping increased to the point that Public Works staff were only able to maintain a small percentage of the streets in-house. The poor pavement conditions were due in small part to the previous winter's severe weather conditions, but more significantly the poor pavement conditions were due to advanced pavement age and minimal pavement section composition, as well as due to not receiving regular proactive maintenance treatments over the life of the pavement sections. In 2023, the city spent almost \$1.3M on contracted pavement patching services.

Since 2023, the city has spent more than \$10,000,000 per year on pavement overlay and street reconstruction improvement projects, and on pavement maintenance projects including crack seal, pavement rejuvenation, and pavement skim and spray patching projects. In addition, public works staff continue to patch potholes and mill and overlay pavement segments with pavement stripping generally confined to tire tracks. Together, these actions have helped to significantly reduce the scope and severity of potholes, pavement stripping and other forms of pavement damage across the city street system.

This spring, staff identified public street segments within 12 distinct areas in 7 residential neighborhoods that would benefit most from pavement skim patching due to poor pavement conditions and due to the fact that the majority of the streets are not programmed in the CIP for reconstruction until 2030 or later, with 4 of the street segments not programmed for reconstruction in the CIP at all. These street segments totaled 4.29 miles in length.

On June 24th, City Council approved plans and authorized advertising bids for hiring a contractor to skim patch street segments totaling 2.41 miles in length within seven (7) of the distinct areas.

Public Works staff patched all deep potholes (deeper than 2-inches) on the streets identified for skim patching in 2025 so the contractor will not have to hand patch any deep potholes in 2025. Below is a summary of the proposed 2025 skim patching process, which is generally a 3/4-inch pavement overlay following the same process used since 2023 minus hand patching of deep potholes by the contractor.

- City staff will sweep streets upon notification by the contractor that they are ready to begin work.
- Contractor will blow any remaining debris and water off the street using compressed air.
- Contractor will apply bituminous tack coat to existing pavement surfaces.
- Contractor will skim patch streets (3/4-inch overlay) except outside edges to maintain drainage.
- Contractor will machine compact skim patching.
- City will sweep patched streets full width.

On August 5, 2025, a total of five (5) bids were received, publicly opened, and tabulated for Maintenance Project #25-56, 2025 Pavement Skim Patching. All bids were found to comply with the approved plans and specifications

and advertisement for bids, and are tabulated below.

Contractor	Bid
North Valley, Inc.	\$132,179.97
Diversified Paving	\$201,170.00
TAG Asphalt and Concrete	\$174,415.00
Asphalt Surface Technologies Corp.	\$213,872.10
Hanson Paving	\$257,698.35
<i>Engineer's Estimate</i>	<i>\$180,000.00</i>

The lowest responsible bid was submitted by North Valley, Inc. of Nowthen, Minnesota, in the amount of \$132,179.97 for the total bid for construction of the improvements in accordance with the approved plans and specifications and advertisement for bids.

Notification:

Advertisements for bids appeared in the Anoka Union Herald on June 27th and July 4th.

Bids were opened publicly on August 5th.

Time Frame/Observations/Alternatives:

Observations:

Based on staff's observations of all contracted skim patching work to date, skim patching is anticipated to have a useful life of at least 3 years, and likely much more. To date, this product is holding up very well to plowing, traffic and weather.

Tentative project schedule:

- August 12th - Council considers award of contract
- Mid-August - Start construction
- September 26th - Final completion

City staff will continue patching all remaining public paved street segments in-house as time allows.

Alternatives:

Alternative #1: Motion to adopt Resolution #25-176 accepting bids and awarding a construction contract for 2025 Pavement Skim Patching, Maintenance Project #25-56.

Alternative #2: Motion of other.

Funding Source:

Payment for this work is proposed to come from the \$600,000 budgeted for 2025 cracksealing, pavement rejuvenator, and pavement patching projects. A total of \$176,000 remains available for 2025 skim patching contracted services.

Recommendation:

Staff recommends Alternative #1.

Outcome/Action:

Adopt Resolution #25-176 accepting bids and awarding a construction contract for 2025 Pavement Skim Patching, Maintenance Project #25-56, to North Valley, Inc. in the amount of \$132,179.97.

Attachments

Resolution 25-176

Form Review

Inbox

Brian Hagen

Form Started By: Bruce Westby

Final Approval Date: 08/07/2025

Reviewed By

Brian Hagen

Date

08/07/2025 03:49 PM

Started On: 07/16/2025 04:28 PM

Councilmember ____ introduced the following resolution and moved for its adoption:

RESOLUTION #25-176

RESOLUTION ACCEPTING BIDS AND AWARDING CONTRACT FOR 2025 PAVEMENT SKIM PATCHING, MAINTENANCE PROJECT #25-56

WHEREAS, numerous public streets in the City of Ramsey require pavement patching; and

WHEREAS, staff recommends skim patching 2.41 miles of public streets in 2025; and

WHEREAS, the City of Ramsey adopted a budget for 2025 including \$600,000 to maintain bituminous pavement on numerous public street segments in support of the City's Pavement Management Program, of which \$176,000 is available for skim patching, and

WHEREAS, pursuant to Ramsey City Council Resolution #25-146 adopted June 24, 2025, the City Council approved plans and specifications and authorized advertisements for bids for Maintenance Project #25-56, 2025 Pavement Skim Patching; and

WHEREAS, bids were advertised in the Anoka County Union Herald on June 27th and July 4th, 2025; and

WHEREAS, five (5) bids were received, opened and tabulated on August 5, 2025, and the following bids were found to comply with the approved plans and specifications and advertisements for bids; and

Contractor	Bid
North Valley, Inc.	\$132,179.97
Diversified Paving	\$201,170.00
TAG Asphalt and Concrete	\$174,415.00
Asphalt Surface Technologies Corp.	\$213,872.10
Hanson Paving	\$257,698.35
<i>Engineer's Estimate</i>	<i>\$180,000.00</i>

WHEREAS, the bid of North Valley, Inc. of Nowthen, Minnesota, in the amount of \$132,179.97 for the total bid for construction of the improvements in accordance with the approved plans and specifications and advertisement for bids, is the lowest responsible bidder and their bid shall be and hereby is accepted.

NOW THEREFORE, BE IT RESOLVED BY THE CITY COUNCIL OF THE CITY OF RAMSEY, ANOKA COUNTY, STATE OF MINNESOTA, as follows:

- 1.) The Mayor and City Administrator are hereby authorized and directed to enter into a contract with North Valley, Inc. in the amount of \$132,179.97 for the construction of said improvements for and on behalf of the City of Ramsey.

The motion for the adoption of the foregoing resolution was duly seconded by Councilmember _____, and upon vote being taken thereon, the following voted in favor thereof:

and the following voted against the same:

and the following abstained:

and the following were absent:

Whereupon said resolution was declared duly passed and adopted by the Ramsey City Council this the 12th day of August, 2025.

Mayor

ATTEST:

City Clerk