



November 19, 2025

Mr. Mark Riverblood
 Parks & Assistant Public Works Director
 City of Ramsey
 14199 Jasper Street
 Ramsey, MN 55303

RE: RAMSEY WATERFRONT PARK EARLY OWNER PROCURED ITEMS

Dear Mr. Riverblood:

Based upon the plans and specifications developed to date, and the expedited schedule of this project, we recommend you seek approval from the City Council to procure the following Owner provided items for the project. These items will be procured through the City’s cooperative purchasing memberships, including Sourcewell and Omnia. A summary of the materials, vendors, and discounted pricing is below. Quotations from the providers are attached. We were unable to obtain a quote for the Umbrellas by Canvas Craft and the Trash Cans/Pavillion Tables by Forms and Surfaces in time for the upcoming City Council meeting. We will provide quotes for those items to be approved at an upcoming City Council meeting.

**City of Ramsey - Waterfront Park
 Owner Furnished Procurement**

Item	Vendor	Price	Cooperative Purchasing
Tables, Chairs, Bike Racks, Benches	Maglin	105,930.00	Sourcewell
Poligon Pavillon Structures (3) and Certified Installation	Northland Recreation (Poligon)	191,950.00	Sourcewell
4" Water Meter	Ferguson	6,931.31	Purchased by City
Adirondack Chairs	Loll Design	39,109.84	Omnia Partners

Total 343,921.15

Thank you, and please contact me with any questions.

Joe Uhlhorn
 Project Executive + Partner
 651-335-4634
 juhlhorn@hu-construction.com



Complex Projects Solved



QUOTATION / ORDER CONFIRMATION

DATE: 11/18/25

QUOTE #: 00084623

COMPANY NAME:

City of Ramsey MN

PROJECT NAME:

The Waterfront Splash Pad - Ramsey, MN

COMPANY ADDRESS:

7550 Sunwood Drive NW
Ramsey MN
US

SHIP TO LOCATION:

MN
US

CONTACT

NAME: City of Ramsey MN

OFFICE NUMBER: 763-427-1410

CELL NUMBER:

EMAIL:

REQUESTED DELIVERY DATE¹:

PAYMENT TERMS: Net 30 Days

MODEL #	DESCRIPTION	COLOUR	QTY	LIST PRICE	SUBTOTAL	SUBTOTAL AFTER DISCOUNTS
MTB-0210-00067	200 Series - 210 Cluster Seating: Structural I-Beam Frame, Thermally Modified Ash Wood Table Top and Attached Backless Benches (2), Surface Mount, Wheelchair Accessible, Umbrella Hole		3	\$3,735.00	\$11,205.00	\$10,084.50
MBR-2300-00001	MBR-2300-00001 2300 Series - Iconic Bike Rack: Cast Aluminum, Surface Mount, 2 Bike Configuration		10	\$410.00	\$4,100.00	\$3,690.00
MCH-1700-00004	FRC1700-MSF-M2-A 1700 Series - Foro Standard Chair: Steel Frame, Laser Formed Steel Seat with Aluminum Back Casting, Laser Design 2, with Arms, Freestanding		14	\$545.00	\$7,630.00	\$6,867.00
MTB-0210-00064	N/A 200 Series - 210 Cluster Seating: Structural I-Beam Frame, Thermally Modified Ash Wood Table Top and Attached Backless Benches (2), Surface Mount, Umbrella Hole		7	\$3,735.00	\$26,145.00	\$23,530.50
MTB-1700-01026	1700 Series - Foro Round Table: 30.18in H x 36in D, Steel Plate		7	\$2,545.00	\$17,815.00	\$16,033.50

*SALES TAX NOT INCLUDED.

Applicable sales tax is subject to sales tax rate at time of shipping.

¹Order completion will be scheduled and you will be contacted by your Maglin representative to advise of scheduled completion date.

("Production Confirmation" notice)

Average lead time of standard products is 6 weeks. Average lead time for modified / original products is 12 weeks.



Base, Steel Tube Post and Outer
 Ring, Thermally Modified Ash
 Wood Table Top, Freestanding

MBE-2300-00057	MBE-2300-00057 2300 Series - Iconic Backed Bench: 70in L, Cast Aluminum Ends, Thermally Modified Ash Wood Seat and Back, Two End Arms, Skate Deterrent	5	\$2,715.00	\$13,575.00	\$12,217.50
MCH-0720-00014	N/A 700 Series - 720 Lounge: 62in L, Laser Cut and Formed Steel Frame, Thermally Modified Ash Wood Seat, Foot Glides	8	\$3,095.00	\$24,760.00	\$22,284.00
MCH-1700-00003	FRC1700-MSF-M2 1700 Series - Foro Standard Chair: Steel Frame, Laser Formed Steel Seat with Aluminum Back Casting, Laser Design 2, Freestanding	14	\$440.00	\$6,160.00	\$5,544.00
MAC-9999-00004	Anchor 50 9999 Anchor: 3/8in x 5in, Stainless Steel, 50 Pack for Surface Mount	2	\$655.00	\$1,310.00	\$1,179.00
FREIGHT	FREIGHT Freight	1	\$4,500.00	\$4,500.00	\$4,500.00

Total before discount: \$117,200

Your Savings: \$11,270

Grand Total: \$105,930.00*

***If this project is tax exempt, the tax exemption certificate must be provided to Maglin at the time of order placement.**

Is this order tax exempt? __ yes __ no

TERMS & CONDITIONS

- Prices for products and freight charges are valid for 30 days from date.
- For more information please see the "Working with Maglin Site Furniture" document.
- Maglin Site Furniture is a material supply company only.
- All products are made to order. Cancellation requests will be subject to restocking fees of 25% of order value.
- Product is sent common carrier. Off-loading at ship to location is the responsibility of the receiving party.
- Should product not be accepted by the later of the Product Confirmation date or order release from product on date, storage charges will apply at a rate of \$10 per skid per day, plus a one-time handling fee of \$60 per skid.

Maglin Site Furniture²

Maglin Contact:

Name: Adam Trakinskas

Phone Number: (519) 539-6776

Email: adam.trakinskas@maglin.com

²Maglin Site Furniture is the registered trademark of Maglin Site Furniture Inc. and Maglin Corporation



MAGLIN®

WOODSTOCK 3-468 Innovation Way, Woodstock ON N4V 0B9
DENVER 999 18th Street, #3000, Denver, CO 80202
www.maglin.com

T 800-716-5506
F 877-260-9393
sales@maglin.com

TO PROCEED WITH YOUR ORDER, PLEASE FORWARD A PURCHASE ORDER AND INDICATE YOUR ACCEPTANCE OF THE TERMS AND CONDITIONS DESCRIBED ABOVE BY SIGNING BELOW:

COMPANY NAME: City of Ramsey MN

Authorized By:

Name: _____

Position: _____

Date: _____

MAGLIN WARRANTY

Maglin Site Furniture manufactures its products to the highest standards of excellence, design integrity, durability, and dependability. We warrant our standard products against any defect in components, standard finishes, or workmanship for a period of five (5) years from the date of invoice. Non-standard (custom and modified) products will receive a warranty for workmanship, materials, and components for a period of five (5) years from date of invoice. This warranty is valid only if the products have been handled, assembled, and installed per Maglin Standard Installation, Product Handling and Assembly Instructions, and if the products have been properly maintained and inspected annually.

This warranty does not cover claims for items having been subjected to misuse, neglect, accident, vandalism, acts of God, damages to items beyond normal use or function, or that have been modified, altered, or repaired by anyone other than Maglin, its authorized representative, or others designated by Maglin.

Maglin will not be held responsible and will not cover costs for damage on any products that were not properly stored prior to installation, damages reported after receiving inspection, or damages reported after installation. Failures due to lack of routine maintenance will not be covered. Minor variations in color, texture or finishes and surface imperfections that result from the casting and/or finishing process will not be covered under warranty.

Maglin will, at its option, repair, replace or refund the purchase price of any items found defective upon inspection by a Maglin representative.

MAGLIN CARE AND MAINTENANCE

SURFACE MOUNT AND FREE-STANDING PRODUCT

All surface mount product is to be anchored to the intended surface with the foot holes using the recommended anchor hardware. Free-standing product can be modified to be surface mount. If product is intended to be movable, please advise your Maglin sales representative at the time of quote/order.

STACKABLE CHAIRS

Chair glides and bumpers should be inspected periodically for wear and replaced as needed. Replacements can be ordered from Maglin. Stacking chairs are designed to be set in place, not thrown, or dragged, especially on uneven surfaces such as paving stones. Throwing chairs can result in damage and is considered "abuse."

HANDLING PRODUCT

Once product has been received and inspected, proper care should be observed when moving product to the installation location, or the temporary area product may be kept until ready to be moved to the site. Product should never be dragged; lift up and down only. Powder coat is highly durable, however, is susceptible to damage from hard unintended hits or contact. Care must be taken to ensure the product is moved safely to the site of installation. Damage occurring after inspection will not be covered under warranty.

²Maglin Site Furniture is the registered trademark of Maglin Site Furniture Inc. and Maglin Corporation



MAGLIN®

WOODSTOCK 3-468 Innovation Way, Woodstock ON N4V 0B9
DENVER 999 18th Street, #3000, Denver, CO 80202
www.maglin.com

T 800-716-5506
F 877-260-9393
sales@maglin.com

PRODUCT INSTALLATION

Maglin products must be installed according to the Maglin Product Installation Instructions. Damage occurring due to improper installation will not be covered under warranty.

CLEANING, CARE AND MAINTENANCE

We suggest regular inspections to identify any loose or missing hardware. These should be tightened or replaced immediately. If any part is found to be structurally cracked or broken it is recommended that the product be taken out of service until the appropriate repairs can be made. Contact Maglin for replacement parts. Should dirt from the environment build-up on any surface, wipe with a soft cloth and mild detergent. Abrasive and commercial cleaners, brushes or coarse steel wool should never be used on any surface.

METAL

All Maglin metal products are undercoated and powdercoated. The Maglin metal-finishing system has been designed and developed through the input of coating experts and more than thirty years of Maglin experience. It sets a standard for coatings and is unsurpassed for public site furniture. If the finish is marred by a sharp object and the steel is exposed, take a fine abrasive sandpaper to the area to improve the adhesion of the primer and touch-up paint.

A quality grade exterior metal primer and topcoat of matching color enamel should then be applied over the prepared surface. Upon request, Maglin can supply metal paint samples for color matching.

An alcohol-based sanitizer (not hand sanitizer, but one made for surfaces) is recommended for disinfecting surfaces. Powder coaters routinely test for full curing in QA via a solvent rub test using methyl ethyl ketone (MEK) which is a significantly more powerful solvent than alcohol. Disinfectant wipes (e.g., Lysol) are an alternative, however, a non-visible area should be tested prior to use.

Pressure washing with a low PSI (1,000 PSI with a 36" distance from the surface) using filtered water and mild detergents work best. Commercial cleaning solutions can remove layers of the finish and should be avoided. Ground water use can result in staining.

HDPE - HIGH DENSITY POLYETHYLENE

Use lukewarm water and soap with a soft cloth, or sponge. We do not recommend any abrasive cleaners, or material, which can scratch or scuff the finish.

LOCK MAINTENANCE

To keep locks functioning properly especially in variable climates, the following is recommended. Use of a lock lubricant is advised every six months, especially in colder climates. Apply the lubricant onto the teeth of the key and insert into the lock and turn back and forth. This will transfer the lubricant from the key onto the lockset. Clean off key after finished.

Depending on frequency of units being emptied, regular tightening of the mounting nut is recommended using a 7/8" wrench. This should be done minimum twice a year. Note: adding Loc-tite is not recommended. Failure to follow recommendations may result in having to purchase new locks.

IPE WOOD

Left alone, Ipe weathers naturally to a silver patina. Cracks and checking in the wood is normal and should be expected as it moves and breathes with the humidity in the air. This is the nature of the material and does not compromise strength or durability. Therefore, stain, varnish, urethane or paint is not recommended for exterior use as any finishing would require constant upkeep depending on climate. Deck Wise Ipe Oil use is recommended if upkeep is desired. There will be discoloration in raw Ipe as not all wood is taken from the same tree, this will result in some material being darker in appearance than others.

THERMALLY MODIFIED ASH WOOD



Thermally Modified Ash left untreated is considered maintenance free. Left alone, the material will weather to a natural grey patina. If it is undesirable to have wood remain grey, maintenance coats can be applied periodically using hardwood exterior penetrating oil such as Cutek.

Cutek is recommended as after the modification process the material will no longer take moisture from the air. Cutek controls this after penetrating the ash. Checking will occur, however use of Cutek will help to minimize and this does not affect the strength or durability of the material. Some discoloration after oiling in the material may be observed, however, thermal ash tends to have a uniform raw appearance. Cutek oils are designed to gradually fade over time rather than peel off, split or crack as is the case with many conventional film forming coatings. For this reason, the rejuvenation and maintenance of Cutek coated surfaces is a simple, fast, and cost-effective process. Recoat time varies widely according to many factors including the age and porosity of the timber, situation, and exposure to the weather. Typically, horizontal exterior smooth surfaces exposed to full weather may require recoating every 6 months to 2 years, while vertical cladding may require maintenance less frequently. The use of varnish or urethane is not recommended and should be avoided.

WEATHERING OF WOOD

GRAYING

Unfinished wood will weather to a natural gray patina.

CHECKING

During the initial drying process, the outside of the wood dries quicker than the interior, which causes differential stresses to develop. The combined effect of these drying stresses in wood often results in the formation of a check or a split. These seasoning characteristics are not problematic; it is important to remember that as wood dries, it becomes stronger. The development of these seasoning characteristics is quite normal. For Ipe, this will occur if Deckwise Ipe Oil is re-applied or not. For Thermal Ash, Cutek will help limit the amount of checking. Both instances are climate dependent for severity.

CHROMA

SURFACE REFINISH

During the service life of Chroma, it is possible that the surface will become scratched after regular use. The matte finish of the material allows it to be refinished if desired. If Chroma needs to be refinished for any reason, the panels may be renewed by sanding with an orbital sander at 10000-12000 RPMs using 3M 360L or 334U grade 240 grit paper.

1. If there are deep scratches, first use a coarse sandpaper on the damaged area 150 grit. Move in a circular motion ensuring to sand at least 12" away from the affected area to ensure it is blended out.
2. Next, wet the surface by misting it with a bottle of water. Now using the 3M 360L of 334U grade 240 grit paper, place the sander on the surface to wet the paper before turning it on.
3. Begin sanding in a circular motion with even pressure and keeping the sander flat until the damage and scratches are fully removed and any marks left by the coarse sandpaper is removed.
4. Wipe down the entire surface with a mixture of mild detergent and water using a dry clean cloth.
5. Finish by applying Maglin - Countertop Cleaner to help resist oils and stains.

SURFACE CLEANING

A regular cleaning of Chroma will help maintain its original look. To clean off any dirt or grease use a soft cloth or sponge and some mild soap and lukewarm water. This will generally be sufficient to restore the surface to its original appearance. Repeat this step twice. The sooner the dirt and grease can be removed, the better. For more difficult stains, dirt, or grease surface cleaners such as Fantastik® or Formula 409® also work well. Avoid rubbing dry cloths on the Chroma surface, this may cause scratching. Scrapers or squeegees should never be used. Strong solvents or chemical cleaners should be avoided.

Once the surface has been cleaned, Magic - Countertop Cleaner is recommended for a final finish. This will help resist stains in the future.



Novus® No. 1 and Brillianize® plastic cleaners can also be used as alternatives. Both products are specifically designed for use on plastics and help panels to resist finger marking and static.

GRAFFITI REMOVAL

When graffiti needs to be removed, please follow the suggested recommendations:

POWDERCOATING SURFACES

Powdercoated surfaces coated with our Anti-Graffiti* coating provide a surface that is easier to clean and remove graffiti from when compared to those coated with Powdercoat alone. For small areas affected by graffiti we recommend the use of World's Best Graffiti Safewipes and for larger areas Worlds Best Sensitive Surface Remover. Follow each graffiti removers' specific instructions for best results.

*Our 2K waterbased Anti-Graffiti coating is a two component, hydrophobic polyurethane that is <100g/L VOC. It provides excellent graffiti resistance, color, and gloss retention.

WORLD'S BEST GRAFFITI SAFEWIPES

STEP 1: Unfold and scrunch up towel. Using a circular wiping motion, remove marks in small areas at a time. Turn the towel over with every wipe to keep the area clean.

STEP 2: After removing the mark, immediately wipe the area with a soft DAMP cloth.

WORLD'S BEST SENSITIVE SURFACE REMOVER

STEP 1: Pour a small quantity of the remover into a small plastic bucket.

STEP 2: Choosing a small area of graffiti, apply the remover to the graffiti using a nylon brush.

STEP 3: Agitate the graffiti with the brush as if you were writing with it. You can use a soft white scourer if suitable or if there is no risk of abrasion.

STEP 4: Wipe the dissolved graffiti away by using a DAMP cloth.

These general guidelines will help provide the most effective results:

- Remove the graffiti as soon as possible
- Remove the cleaner from the coating as soon as it has had time to act
- Make sure that the loosened graffiti is not spread onto clean areas
- Wipe clean with a damp cloth

For powdercoated products that do not have an Anti-Graffiti coating, the same cleaning methods can be applied. Note that the surfaces may experience a slight reduction in glossiness in areas where graffiti has been removed. Note that black permanent marker is a dye-based product and can permanently mark the coating especially on lighter colors. If cleaned off quickly with either of the two 'World's Best' removers, little or no marking will be visible. Marker left to age can be minimized using the same process but sometimes it cannot be completely removed.

IPE AND THERMAL ASH WOOD

Wait for paint or marker to dry if graffiti has recently occurred. Sand affected area and the entire board using an orbital sander and 180 grit sandpaper. The sandpaper should be sufficient to remove all graffiti. Sand remaining boards that have not been graffitied. Then apply Ipe oil for a uniform appearance.

Alternately, sand and oil the effected areas only and in 6-12 months the area will patina and begin to match surrounding boards. Applying Ipe oil to all unaffected boards will help initially blend their appearance to the sanded and oiled boards treated for graffiti.

HDPE - HIGH DENSITY POLYETHYLENE

HDPE is a self-lubricating material and therefore, not many other materials adhere well to it. A stiff nylon brush combined with World's Best Transgel can be effective at cleaning within the grooves and crevices of the plastics texture. Care should be taken not to apply too much



MAGLIN®

WOODSTOCK 3-468 Innovation Way, Woodstock ON N4V 0B9
DENVER 999 18th Street, #3000, Denver, CO 80202
www.maglin.com

T 800-716-5506
F 877-260-9393
sales@maglin.com

pressure or scrub too vigorously as it may dull the surface. World's Best Graffiti Safewipes can also be effective at removing most types of graffiti.

QUOTATION



Phone: 651-815-4097

10085 Bridgewater Bay
Woodbury, MN 55129

Project : Ramsey Waterfront

Email: info@northlandrec.com

To: City of Ramsey
7550 Sunwood Drive NW
Ramsey, MN 55303

Date: 11/19/25
Contact:

Sourcewell Contract Pricing

City of Ramsey Member # 17939 / Poligon Member # 012621-PPC

QTY	ITEM	DESCRIPTION	UNIT	EXTENSION
Poligon REK (Gable Roof) 16' x 24'				
3	Shelter	All Steel Frame Stained Tongue & Groove with Standing Seam Metal Roof 4 Columns, 9' eave height, 10:12 pitch Electrical Access and 3 Cutout Locations Poli 5000 Paint System - Standard Color Chart Selection Wind Speed 110 mph / Ground Snow Load 50lb Cast-In-Place Anchor Rods, Nuts and Template Stamped Engineered Drawings & Shipping to Ramsey MN	\$48,975.00	\$146,925.00
1	Allowance	Note - Allowance for gable end modifications to accept cedar lap siding by others - actual cost will be determined upon engineered drawings		\$10,000.00
1	Discount	Sourcewell Discount		-\$9,975.00
	Installation	Installation of above shelter materials only will be invoiced separately		
		<p style="color: blue;">Engineered Drawings Lead Time Currently Is 5-6 Weeks Production Lead Time Is Currently 10-12 Weeks</p> <p>This quote does NOT include installation of the shelter</p>		
NOT	Included	Installation of concrete footings, concrete pad, building permits, bonding costs, special inspections, site work, etc		

Site preparation and restoration by others

- * Quotation is valid for 30 Days
- * Freight based - shipping to Ramsey MN
- * Estimated ship date is TBD based upon engineered drawing approval
- * Terms based on Based on credit approval - downpayment may be required
- * Orders will be placed upon receipt of Purchase Order made out to **Northland Recreation** or your signed acceptance.

Sub Total	\$146,950.00
Freight	Included
Tax -Exempt	\$0.00
TOTAL	\$146,950.00

Quote By: **Sue Ayers**

THANK YOU !

Accepted By: _____

Date: _____

NOTES: Poligon shelter listed on this quote will be engineered based on this design below. Internal anchor bolts at finished grade. Other anchor bolt layouts are available but may require additional engineering at an additional cost due to post length needed

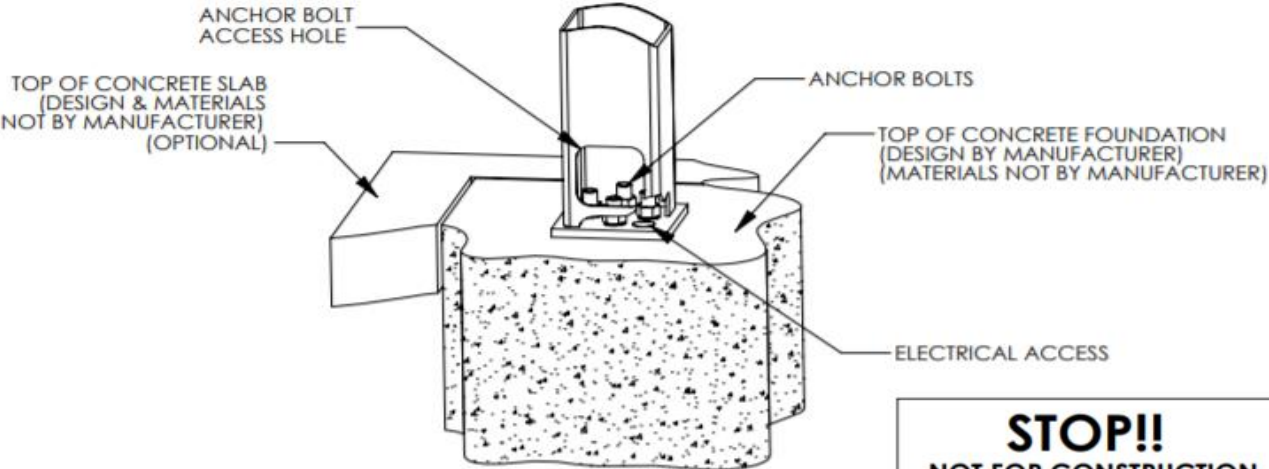

INTERNAL ANCHOR BOLTS
(AT FINISH GRADE)

<p>STOP!! NOT FOR CONSTRUCTION</p>
<p>USE FOR PRELIMINARY PLANNING AND ESTIMATING ONLY</p>

Mulcare Contracting LLC

16675 Hutchinson Court
Lakeville, MN 55044
952-215-8659

QUOTATION

Date 11.19.2025

Bill To

City of Ramsey
7550 Sunwood Drive NW
Ramsey, MN 55303

Ship To

Ramsey Waterfront

PO #

Terms Net 30

Ship Date TBD

Due Date

ITEM	DESCRIPTION	QTY	AMOUNT
Installation	<p>Installation of Poligon Gable Roof Shelter 16' x 24' Factory Stained Tongue & Groove Standing Seam Metal Roof Poligon Certified Installation / Installer</p> <p>Installation of material only Installation is not based on prevailing wages</p> <p><i>* It is understood that <u>all</u> footings will be poured at the <u>same elevation</u> If footings are not at the same elevation - shelter will not be installed *</i></p> <p>Does Not Include: Building Permits Special Inspections Site Work / Site Prep Any / All Concrete Work Footings (by others)</p>	3	15,000.00 Each

Subtotal 45,000.00

Sales Tax (0.0%) NA

TOTAL \$45,000.00

Accepted By _____

Date _____

Thank You ~

Deliver To: From: Brian Rollins brian.rollins@ferguson.com Comments:
--

FERGUSON WATERWORKS #2518
Price Quotation
Phone: 763-560-5200
Fax: 763-560-1799

Bid No: B180519
Bid Date: 11/18/25
Quoted By: TMF

Cust Phone: 763-427-1410
Terms: NET 10TH PROX

Customer: CITY OF RAMSEY
METER ACCOUNT
7550 SUNWOOD DR NW
RAMSEY, MN 55303

Ship To: CITY OF RAMSEY
METER ACCOUNT
7550 SUNWOOD DR NW
RAMSEY, MN 55303

Cust PO#: 4X20 MACH10 R900I

Job Name: METER ACCOUNT

Item	Description	Quantity	Net Price	UM	Total
NEU3D2G1	4 MACH 10 R900I 20 LENGTH USG	1	5588.150	EA	5588.15
FMA3TRADESURNEP	NEPTUNE TRADE SURCHARGE FEE	1	279.410	EA	279.41
M431T11PLF	LF 4 MTR FLG KIT SET	1	523.750	EA	523.75
Net Total:					\$6391.31
Tax:					\$0.00
Freight:					\$0.00
Total:					\$6391.31

Quoted prices are based upon receipt of the total quantity for immediate shipment (48 hours). SHIPMENTS BEYOND 48 HOURS SHALL BE AT THE PRICE IN EFFECT AT TIME OF SHIPMENT UNLESS NOTED OTHERWISE. QUOTES FOR PRODUCTS SHIPPED FOR RESALE ARE NOT FIRM UNLESS NOTED OTHERWISE.

Due to the uncertain impact of potential tariffs, Ferguson's quotation/proposal has not included any provision or contingency for future tariffs or increase of existing tariffs. Ferguson reserves the right to adjust prices to reflect the impact of any new or increased tariffs that affect our costs at the time of shipment. Ferguson will provide notice of any such adjustments along with documentation supporting the changes.

CONTRACTOR CUSTOMERS: IF YOU HAVE DBE/MBE/WBE//VBE/SDVBE/SBE GOOD FAITH EFFORTS DIVERSITY GOALS/ REQUIREMENTS ON A FEDERAL, STATE, LOCAL GOVERNMENT, PRIVATE SECTOR PROJECT, PLEASE CONTACT YOUR BRANCH SALES REPRESENTATIVE IMMEDIATELY PRIOR TO RECEIVING A QUOTE/ORDER.

Seller not responsible for delays, lack of product or increase of pricing due to causes beyond our control, and/or based upon Local, State and Federal laws governing type of products that can be sold or put into commerce. This Quote is offered contingent upon the Buyer's acceptance of Seller's terms and conditions, which are incorporated by reference and found either following this document, or on the web at <https://www.ferguson.com/content/website-info/terms-of-sale>
Govt Buyers: All items are open market unless noted otherwise.

LEAD LAW WARNING: It is illegal to install products that are not "lead free" in accordance with US Federal or other applicable law in potable water systems anticipated for human consumption. Products with "NP" in the description are NOT lead free and can only be installed in non-potable applications. Buyer is solely responsible for product selection.



HOW ARE WE DOING? WE WANT YOUR FEEDBACK!

Scan the QR code or use the link below to complete a survey about your bids:

<https://survey.medallia.com/?bidsorder&fc=2518&on=24741>



Loll Designs
 5912 Waseca Street
 Duluth, MN 55807
 Phone: 877.740.3387
 www.lolldesigns.com/contract
 contract@lolldesigns.com

Customer PO: City of Ramsey Waterplay Park OMNIA
Project Name: City of Ramsey Waterplay Park

Bill To: City of Ramsey MN
 7550 Sunwood Drive NW
 Ramsey, MN
 55303

Prepared by: Ashley Hochstein
Email: ashleyh@lolldesigns.com

SALES QUOTE

Quote Number: L100007166
Created Date: 11/18/2025
Expiration Date: 1/17/2026
SAGE Account Number:
Payment Terms: NET 30 DAYS
Shipping Method: LTL COMMERCIAL

Specifier: Damon Farber Landscape Architects

Delivery Contact Name: TBD
Delivery Contact Phone:
Delivery Contact Email:

Ship To: City of Ramsey MN
 7550 Sunwood Drive NW
 Ramsey, MN
 55303

SKU	Description	QTY	Unit Price	Net Price	Discount	Sidemarks	Total Price
LL-AD-4SFT-CH-LG	Tall Adirondack Chair (Flat), Cable Holes, Leaf Green	56	\$907.00	\$634.90	30%		\$35,554.40

*All Prices Are USD\$

-The quoted price may include estimated tax, duties and tariffs. Actual tax, duties and tariffs shall be purchaser's responsibility and may be added to an invoice as a separate and additional charge to purchaser unless an acceptable exemption certificate is presented.

-All orders are subject to Loll Designs' Terms and Conditions of Sale (including Disclaimers and Limitations of Remedies) posted on lolcontract.com/terms and incorporated herein by reference.

-Cancelled orders will be subject to a 100% restocking fee.

-All orders are made to order and therefor not eligible for returns.

-Purchaser is responsible for confirming options, materials, quantities, etc., for

Subtotal: \$50,792.00
Discount Amount: \$15,237.60
Total Price: \$35,554.40
~~**Tax:** \$3,177.70~~
Freight: \$3,555.44
Grand Total: ~~\$42,287.54~~
\$39,109.84

completeness and conformity to plans and specifications.

-Most products ship knocked down and require assembly. Please consult our price list for shipping method by SKU.

-Will call shipments will incur a handling fee of 2% of net product cost

-All orders ship upon completion of fabrication. A one-week grace period may be available, after which storage fees apply.

-Orders that require storage will be charged a storage fee of 1% of net product cost for each week past the acknowledged ship date.

-Prices are based on quantities shown; quantity changes may affect price.

-Loll Designs is a material supplier only and ships via best method. Customer is responsible for offloading.

-This agreement may be signed by the parties separately and together they shall be deemed one binding, original agreement.

-Purchaser shall pay all costs and expenses paid or incurred by Loll Designs for goods purchased including without limitation, reasonable attorney fees and collection costs.

Balances on invoices not paid within 30 days of the date of invoice, or within an alternative period of time as determined and indicated by Loll Designs, shall incur an interest rate of 18% per annum. Cash discounts are not offered.

Signature: _____

Print Name: _____

Title: _____

Date: _____

**** REMIT TO: Landscape Forms DBA Loll Designs
P.O. Box 78000 Dept: 78073 Detroit, MI 48278
Memo field must include quote number ****