

**CC Regular Session**

**Meeting Date:** 10/28/2025

**Primary Strategic Plan Initiative:** Connect the community through Parks, Trails and Recreational Programming.

**Title:**  
Approve Construction Management Services for The Waterfront Waterplay Project

**Purpose/Background:**  
The purpose of this case is to authorize H + U Construction for construction management services for The Waterfront project—and also, to authorize staff and H + U to obtain quotes for mass grading of the site this Fall.

In September, the City issued a Request for Proposal (RFP) for a Construction Manager at Risk (CMAR) with a Guaranteed Maximum Price (GMP) for the water play plaza and associated improvements at The Waterfront. Three pre-qualified firms were invited to submit proposals, and on October 13th, a panel consisting of city staff and Damon Farber Landscape Architects' representative conducted a thorough interview of two firms, and unanimously determined that H & U Construction is ideally suited for all the work to be performed in the coming months at the park. H + U will work with the Project Team (City staff and Damon Farber Landscape Architects as the DESIGN TEAM) to provide pre-construction and construction services including cost and schedule estimating, bidding, and day-to-day construction management for the complex park project. (Damon Farber will still provide all the professional design services, to include preliminary design, concept design, schematic design, design development, construction documents and construction administration as they were engaged to do earlier this year.)

On October 21st, 2025, the Public Works Committee recommended to City Council, approval of a contractual agreement with H + U Construction for construction management services for The Waterfront waterplay park improvement project, in the form of a Construction Manager at Risk agreement.

Attached is the city-issued RFP which provides considerable detail on the scope, timing, and responsibilities of and for the construction management firm. The second attachment is H + U's proposal, which includes a schedule (work plan on page 4), which responds to the RFP and challenges of this approximately \$5M park project.

**Time Frame/Observations/Alternatives:**

**Construction Management Services**

As indicated, this case is to authorize a contractual agreement with H + U Construction for construction management services for The Waterfront waterplay park improvement project. That standard form is included as the third attachment, AIA Document A133-2019. This agreement includes an estimated fee schedule consisting of two parts—Preconstruction & Bidding Phase Services, and Construction & Closeout Phase Services.

The Preconstruction & Bidding Phase Services will be a not-to-exceed amount of \$50,000, and that scope of work is described in the city-issued RFP, and also reflected in H + U's proposal and Schedule. These preconstruction services may be summarized as cost estimating, constructability reviews, schedule validation, and value engineering recommendations to ensure delivery of the overall project within the established budget (yet to be determined) and the July completion schedule.

The Construction & Closeout Phase Services is also included in Document A133-2019 but as an estimate. At the time the preconstruction and bidding services are concluding, H + U will issue a Guaranteed Maximum Price—the agreement will then return to City Council for acceptance of GMP and corresponding amendment of the agreement. To reiterate, this case authorizes entering into an agreement with H + U Construction for the preconstruction services for a not-to-exceed amount, which will enable the Design Team (now to include the construction manager) to complete the Plans and Specifications for competitive bidding, at which time H + U will issue the GMP which would then be considered for acceptance by Council in January, along with final approvals to complete the park project.

For the meeting; staff will present imagery of the considerable progress on plans for the park project, highlight near-term activity of the Design Team—and describe the necessity of performing the mass grading this Fall, to prepare for full-on construction to begin in February/March 2026.

The estimates in the table below are provided to communicate the work that has been approved and underway, as well as moving forward, beginning with the \*preconstruction phase wherein H + U Construction will prepare detailed cost estimates for this project.

Preliminary Cost Forecast (informational only)—does not include O & M

Activity/Work	Investment (estimate or approved amount)	Timeline
Design, engineering, plans and specifications — Damon Farber Architects	\$269k	Approved June 2025
Restroom and support building — design, fabrication and delivery (not on-site construction)	\$305k	Approved Sept. 2025
Sewer and water service lines	\$148k	Approved Sept. 2025
*Construction management services and General Conditions	\$50k - \$700k	Pending: October '25, January '26
Mass grading, import class 5 to site	\$120k	Pending: November '25
Owner procured shelters (3) and outdoor furnishings (eliminates construction manager fees)	\$1.1M	Pending: Dec. '25/Jan. '26
SAC/WAC, permitting, owner contingency, signage etc.	\$600k	Pending: Feb. '26/July '26
Construction costs (all trades and scope)	\$2.4M	Pending: Feb. '26/July '26
Running budget estimate (preliminary and informational only) — all costs totaled over time	\$4.6M to \$5.6M	2025 through 2026

**Funding Source:**

The Construction Management Services that this case discusses, would be funded by the Park Trust Fund.

**Recommendation:**

The Public Works Committee and staff recommends entering into a contractual agreement with H + U Construction for construction management services for The Waterfront waterplay park improvement project, in the form of a Construction Manager at Risk agreement.

**Outcome/Action:**

Motion to approve a contract with H + U Construction for construction management services for The Waterfront waterplay park improvement project, at a not-to-exceed amount of \$50,000, until amended in January 2026.

---

---

**Attachments**

RFP for CMAR  
H & U Construction proposal  
A133 contract w fee estimate  
GMP amendment sample  
Progress report  
The Waterfront Draft Drawings  
Preliminary Estimates

---

---

**Form Review**

<b>Inbox</b>	<b>Reviewed By</b>	<b>Date</b>
Bruce Westby	Bruce Westby	10/23/2025 02:39 PM
Brian Hagen	Brian Hagen	10/23/2025 03:36 PM
Form Started By: Mark Riverblood		Started On: 10/17/2025 11:14 AM
Final Approval Date: 10/23/2025		

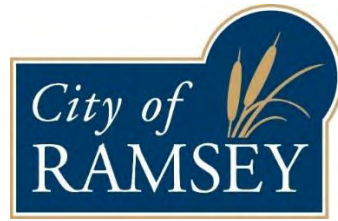

# REQUEST FOR PROPOSAL

## CONSTRUCTION MANAGER AT RISK

CITY OF RAMSEY - THE WATERFRONT WATERPLAY

September 30, 2025



## TABLE OF CONTENTS

### Contents

PREQUALIFICATION BACKGROUND .....	4
GENERAL INFORMATION .....	6
PROJECT BACKGROUND .....	6
PROJECT SCHEDULE AND BUDGET .....	7
PROJECT COST ESTIMATE AND BUDGET .....	9
SCOPE OF SERVICES .....	9
RESPONSIBILITIES .....	10
PUBLIC AND STAKEHOLDER ENGAGEMENT .....	10
DESIGN .....	10
CONSTRUCTION PLANNING AND SCHEDULING .....	11
CONSTRUCTION AND CONSTRUCTION ADMINISTRATION .....	12
COST MANAGEMENT .....	13
SUBCONTRACTOR SELECTION STRATEGY/BIDDERS LIST .....	13
COORDINATION MEETINGS .....	13
SCHEDULE MANAGEMENT .....	14
PROJECT REPORTING .....	14
QUALITY MANAGEMENT .....	14
SAFETY .....	15
PROJECT CLOSEOUT .....	15
OTHER .....	15
SUBMISSION REQUIREMENTS .....	16
COMMUNICATIONS .....	16
SCHEDULE .....	17
SITE LOGISTICS / DISRUPTION AVOIDANCE .....	17
EVALUATION CRITERIA & PROCEDURES .....	17
SELECTION TEAM & INTERVIEWS .....	17
SELECTION CRITERIA .....	18
CONDITIONS OF REQUEST AND REQUIREMENTS .....	19

## PROJECT INTRODUCTION AND CMAR RFP INVITATION(S)

### PREQUALIFICATION BACKGROUND

The City of Ramsey is pursuing a Construction Manager at Risk (CMAR) delivery method for The Waterfront project—an approximately 2-acre park project focused on water play features, scheduled to open by July 1, 2026. Due to the specialized nature of the work, including integrated aquatic systems, complex site coordination, and a non-negotiable summer opening, the CMAR approach was selected to enable early contractor involvement, constructability input, and cost/schedule control.

To meet the project's goals while complying with applicable procurement statutes, the City intends to issue a **CMAR Request for Proposals (RFP)** to three pre-qualified firms. This approach is consistent with Minnesota Statutes § 471.345 (Uniform Municipal Contracting Law) and § 16C.28 (Best Value Procurement), which allow municipalities to evaluate and award construction contracts using qualifications, experience, schedule, and other performance-based criteria—not solely low bid.

The rationale for inviting three 'prequalified' CMAR firms is as follows:

- 1. Proven Relevant Experience**

The invited firms have each successfully completed public park projects in Minnesota that included significant aquatic components, all in collaboration with the same landscape architect leading this project. Their shared history with the Design Team demonstrates an ability to coordinate effectively on fast-tracked, public-sector projects of similar scope and complexity. This minimizes learning curves and reduces risk related to miscommunication or delays.

- 2. Best Value and Schedule-Driven Selection**

With a construction window of less than six months (February–June 2026), it is imperative to bring in a CMAR that can immediately engage in preconstruction services, including value engineering, phasing, and cost estimating. The three firms receiving this RFP are uniquely positioned to do so based on their prior experience, internal resources, and understanding of CMAR protocols. (A broader open solicitation would significantly increase the administrative timeline and could introduce unqualified or inexperienced responders—jeopardizing schedule certainty.)

### 3. **Maintaining Fair Competition**

While the solicitation is limited to three firms, each was selected based on objective criteria: relevant past experience, successful CMAR project delivery with aquatic scope, and capacity to meet the project's aggressive timeline and budget constraints (estimated at under \$4 million total construction cost). All three firms will receive the same RFP documents, evaluation criteria, and scoring methodology, consistent with Minnesota Best Value procurement practices.

### 4. **Statutory Compliance**

The City will fully comply with the requirements of Minn. Stat. § 16C.28, including clear identification of evaluation criteria in the RFP and the relative weight of price versus other qualitative factors. The selection process will be documented and defensible under audit. Additionally, Minn. Stat. § 471.345 permits municipalities to use a competitive RFP process sans public advertising when professional or technical expertise is required, provided that the selection process remains competitive and transparent.

By inviting these three highly qualified CMAR firms, the City is balancing the need for **competitive procurement** with the equally critical goals of **project quality**, **timely delivery**, and **cost containment** – all of which align with Minnesota's procurement rules and the public interest.

## PROJECT OVERVIEW

### GENERAL INFORMATION

The City of Ramsey (“City”) is seeking proposals for a Construction Manager at Risk (“CMAR”) with a Guaranteed Maximum Price (“GMP”) for the water play plaza and associated improvements at The Waterfront. The selected firm will work with the Project Team which will be comprised of City staff as Owners Representatives, and Damon Farber Landscape Architects (“DESIGN TEAM”) to provide preconstruction and construction services including cost and schedule estimating, bidding, and day-to-day construction management for the public park project consisting of a water play experience with support structures and associated landscape in Ramsey, MN.

The City has retained an architectural firm, Damon Farber for professional design services to provide programming and preliminary design, concept design, schematic design, design development, construction documents and construction administration.

### PROJECT BACKGROUND

**The Waterfront is a 16-acre public park with the 2-acre project site centered around a warm-weather water play experience, yet thoughtfully designed to function as an inviting and engaging public plaza throughout all seasons.** While the interactive water elements provide a vibrant and dynamic atmosphere during warmer months, the surrounding landscape, seating, architectural features, and site amenities ensure that the space remains visually appealing, inviting and accessible year-round. The project aims to serve as a community hub that balances seasonal activity with lasting placemaking. The project emphasizes integrated landscape design, interactive water features, and user comfort, all within a carefully managed construction schedule and budget.

At the core of the park will be a large decorative concrete plaza, surrounded by densely landscaped earthen berms and natural stone seating areas. From the highest point of the site, a cascading waterfall will flow into a designed stream feature that runs through the plaza. The plaza and stream will include more than 90 ground-mounted spray nozzles, creating a variety of interactive spray patterns. Water from the system will be collected via two main drains before cascading over a second constructed waterfall into an existing adjacent forebay before entering the 7+ acre deep-water recreational pond.

To support the anticipated volume of seasonal visitors, the project includes a new park support building housing men’s and women’s restrooms, a family changing room,

mechanical and utility space, and secure storage. Enhancing the visitor experience, the site will also feature:

- Three permanent shade pavilions
- Several fixed shade canopies
- Site furniture, including Adirondack chairs, backed benches, chaise loungers, bistro-style tables and traditional picnic tables
- Three permanent natural gas fire features for extended seasonal use

## PROJECT SCHEDULE AND BUDGET

- **CMAR Procurement & Preconstruction:** Fall 2025
- **Final Bidding & GMP Establishment:** January 2026
- **Construction Start:** February 2026
- **Substantial Completion / Park Opening:** July 1, 2026

The project at present has a working budget of approximately \$4 million, inclusive of all site work, utilities, structures, and amenities. The CMAR will be expected to provide **preconstruction services that include cost estimating, constructability reviews, schedule validation, and value engineering recommendations** to ensure delivery within this budget and on schedule.

### Primary Project Scope Includes:

- Earthwork and grading
- Underground utilities – sanitary sewer & water main (installed fall 2025)
- Underground drain tile and storm sewer for site drainage
- 900 sf park support building
- (3) 384 sf shade pavilions
- 17,000 sf of decorative concrete paving
- Metal guard rails
- 10-15 permanent fabric shade umbrellas
- 145 tons of natural stone
- Irrigation and irrigation pump station with pond intake
- 3,000 sf of synthetic turf
- 150 lf of aluminum fencing
- Landscape plantings

#### Water Play Detail Includes:

- 90 plus in-ground spray nozzles for water play
- Water play controls
- In-building manifolds
- 3 in-ground manifold boxes
- 6 or more in-ground LED lights
- Ground spray piping
- Splash pad drains and related piping
- Low voltage wiring and conduit for site manifold boxes
- Splash pad control system in mechanical room
- Grounding grid for ground spray assemblies and manifold boxes

#### Electrical Detail Includes:

- Site will be fed from a utility transformer on the north end to the utility building CT Cabinet & utility meter.
- Service will be 400 amps at 120/208 volt, 3-phase with a panel board inside the building to feed lighting & power.
- Site lighting provided by 12' high pole mounted fixtures. Quantify of 13.
- Catenary lighting (cable mounted lights) hanging over a portion of the plaza.
- Pavilion Lighting/Electrical:
  - Linear fixtures on the underside of the pavilion ceilings
  - Pendant mounted fixtures running down the middle of the pavilions
  - Receptacles provided for gatherings
  - Receptacles & lighting for pavilions fed from panel inside the building

#### Irrigation Detail Includes:

- Irrigation pump station with cabinet (at pond shoreline) with VFD pump powered from panel inside the building.
- Two-wire Aclima Irritrol Controller with in-ground soil moisture sensors, and various zone valves, some placed in the manifold boxes.
- Irrigation mainlines sufficient to serve irrigation zones beyond the 2-acre waterplay project, various irrigation zones consisting of rotators, sprays and drip irrigation – with one flow-controlled zone to supplement the lower waterfall feature above the forebay.

## PROJECT COST ESTIMATE AND BUDGET

Based on facility needs discussed through Schematic Design, the City is estimating a project cost of +/- \$4 million dollars, which includes all construction phases of the project from mobilization to closeout and commissioning. The budget established after the CMAR is on-boarded, will be inclusive of all aspects of final design and construction including soft goods, FF&E, and program-based needs, if any.

This project will include Owner Procured and Contractor Installed items. These are either or both items with longer lead times or acquisitions made through cooperative purchasing contracts that would lower the CMAR management costs as a percentage of construction value. Owner procured items known at this time that would fall above and beyond the construction value are:

- Romtec restroom and support building
- Shade pavilions
- Site furnishings to include outdoor furniture, waste receptacles and other movable fixtures

## SCOPE OF SERVICES

City intends to enter into an open book Cost of Work plus a fee with a Guaranteed Maximum Price contractual arrangement with the selected CMAR through GMP. The contract will be negotiated for the construction work required, but City will retain the option to select a different CMAR if the City and the selected CMAR cannot agree on a GMP. City intends to use a modified AIA Document A133-2019 Agreement between the Owner and CMAR. An amended AIA Document A201-2017 General Conditions of the Contract for Construction with added supplementary conditions may also be utilized. The City reserves the right to modify the standard forms of agreement to include provisions consistent with City policies. **The Responder must make requests for modifications to the contract documents in the RFP submission if any. Requests for modifications after selection will not be considered. Requests not identified in the proposal constitute an incomplete RFP submission and are grounds for disqualification.**

## RESPONSIBILITIES

The CMAR will be responsible for, but not limited to the following:

### PUBLIC AND STAKEHOLDER ENGAGEMENT

- Participate in City Council meetings as needed.
- Attend, present, answer inquiries, and supply information for public and stakeholder meetings.
- Provide information and updates for project website, and other City communications.

### DESIGN

Design is anticipated to be completed at 50% Construction Documents at CMAR onboarding, with possible alternates still under evaluation. The CMAR shall actively participate in any remaining design meetings, constructability reviews, provide cost estimate(s), and ultimately develop a GMP. More specifically, the CMAR shall provide the following, but not limited to, preconstruction services and activities:

- Assist City and Design Team with keeping the project within the established project budget.
- CMAR to provide recommendations to DESIGN TEAM and City regarding materials, building components and systems, and also evaluate all project systems, components and materials for long term performance, life cycle cost analysis, and economy.
- CMAR to provide cost control resources for the Project Team during the remainder of the Construction Documents (“CD”) phase of design for the pump room expansion, which includes reviewing and monitoring the development, and preparation of documents to maintain the project cost within the project budget. CMAR to notify DESIGN TEAM and City of potential cost issues during the development of the drawings and specifications that may have an impact on the cost of the work. Work collaboratively with City and DESIGN TEAM to develop alternatives to keep the project estimates within the fixed budget. Ultimately, CMAR owns and is responsible for the schedule and estimate.

- CMAR to provide formal review and comment, and cost estimate at 100% complete CD documents. CMAR to provide value analysis/engineering ideas and provide associated cost estimates.
- CMAR to prepare scope and bid packages in coordination with DESIGN TEAM and should anticipate multiple bid packages. CMAR to develop a strategy for issuing bid packages that facilitate the completion of those packages. The purpose is to utilize this bidding package strategy to gain the most advantageous issuing of documents, to maximize local subcontractor participation, minimize construction duration while allowing the bid packages to be completed efficiently. Early bid packages may be required of certain building components that are subject to long lead times and/or sub-trades that have high potential for cost escalation.
- GMP to include pricing of alternates as defined by DESIGN TEAM which will be equal to approximately 5% of the GMP.
- CMAR along with DESIGN TEAM to coordinate with building inspections and City planning for plan reviews prior to permit submission. These are reviews by City Staff and stakeholders and are separate and in addition to required reviews by Engineering, and Building Inspections.

CMAR to be a resource to DESIGN TEAM as they prepare Construction documents that conform to the agreed upon scope of the work that is included in the GMP.

## CONSTRUCTION PLANNING AND SCHEDULING

- CMAR to work with the City and DESIGN TEAM to develop a work plan for design activities in support of the schedule and budget for the project.
- During the remainder of the construction documents phase, the CMAR will develop the project master schedule including integration of the DESIGN TEAM design efforts, key City activities, preconstruction activities, procurement, construction activities, and work performed by other parties.
- **CMAR to schedule all construction activities to optimize efficiency and to ensure the goal of substantial completion and being fully open for public use on July 1<sup>st</sup>, 2026.**
- CMAR to provide disruption avoidance planning and

communication with stakeholders and for the safety of residents using the adjoining park and trail areas during construction.

- Ongoing, the CMAR will evaluate all systems, components, and materials for constructability, sustainability, economy, long-term performance for use intended and schedule impacts, and provide recommendations for preferred options consistent with cost and schedule goals.
- In addition, the CMAR will identify long lead times requiring early bid packages and recommend issue dates for same to meet the above completion date.

## CONSTRUCTION AND CONSTRUCTION ADMINISTRATION

- CMAR to provide competent, experienced full-time staff, including an experienced construction field superintendent and project management team to coordinate the work, maintain the progress of the subcontractors, coordinate with ongoing activities and operations, and provide overall direction to the project during the construction phase. Establish on-site organization and levels of authority to carry out the overall plans of the construction team.
- Demonstrate high levels of effective, proactive project leadership.
- Work cooperatively and constructively with members of the Project Team to foster positive relationships that support positive outcomes for the team members and the project.
- **CMAR to designate a point of contact/project manager from construction documents design through construction, which will not be reassigned.**
- CMAR will be contractually obligated to not reassign key staff members to other projects without the City's prior written consent. The City will have approval rights to any and all new personnel assigned to this project.
- Before the beginning of construction, and in agreement with the Owner, CMAR will coordinate and lead all pre-construction conferences.
- CMAR will work with City, Owner's representative, DESIGN TEAM in coordinating all RFIs, shop drawings, and any material testing.
- CMAR shall coordinate schedules with all City's vendors.

## COST MANAGEMENT

- Implement effective cost management control and tracking procedures to provide the City with the opportunity to make such decisions as required to keep project cost within the fixed budget.
- Implement and maintain cost control methods with “open book” sharing of cost information.
- CMAR to inform City of pending cost issues within five (5) business days of identifying potential issues.
- Implement and maintain a current log of pending cost issues impacting the final cost of the project and review no less than monthly with the City.
- Work with the City and DESIGN TEAM to develop and implement a change management process for the project.

## SUBCONTRACTOR SELECTION STRATEGY/BIDDERS LIST

- Bid packages will be developed and include invitations to bid, instructions to bidders, and other forms and supplements needed to convey requirements. CMAR shall demonstrate familiarity with the QuestCDN bidding platform in the RFP response or presentation. The Owner’s representative, and DESIGN TEAM will be involved with bidding process and bidding strategy with the CMAR for all work reflected in the Construction Documents, including consideration for vendor outreach, and specifically to provide opportunities for small businesses based in the City of Ramsey.

## COORDINATION MEETINGS

- Conduct weekly job site meetings that include appropriate subcontractors, City representatives, and DESIGN TEAM representatives to review open issues, schedule work, and resolve pending and upcoming issues. CMAR to prepare a written agenda in advance of each meeting. CMAR to maintain a list of action items with identification of responsible party and due dates for each item. CMAR to distribute written meeting minutes and action item list within 48 hours of each meeting.

## SCHEDULE MANAGEMENT

- CMAR to prepare and manage a logic-based project schedule indicating key milestone events, dates, and responsibilities. Project schedule to include design efforts, preconstruction activities, procurement of goods and construction activities. CMAR to provide regular monitoring of the actual progress versus the scheduled progress, identify any variances and prepare a written action plan along with an updated schedule to maintain on-track with the substantial completion date.
- CMAR to determine the adequacy of the subcontractors' personnel and equipment and the availability of materials and supplies to meet the schedule. Report status no less than weekly in regular weekly coordination meetings.
- CMAR to prepare a short-term (2- to 3-week look-ahead) schedule on a weekly basis.
- Coordinate City-purchased and/or third party provided restroom and support building, furniture, fixtures, and equipment with construction of the project.

## PROJECT REPORTING

- CMAR to prepare a monthly report with each progress billing that details a project work status report, buy-out to schedule of value analysis, contingency status, schedule status and project progress commentary with applicable job-site photos. Provide other formal communications as requested by City.

## QUALITY MANAGEMENT

- CMAR to complete a quality/coordination/constructability review of each bid package prior to issuing bid documents to subcontractors.
- Complete construction of the work in strict accordance with the quality requirements established by the contract documents.
- All testing and independent inspection services required will be secured and paid for by the City. CMAR to cooperate and coordinate with testing and inspection service agencies. CMAR will be responsible for the cost of excessive additional testing due to failed

- tests.
- Develop an initial CMAR punch list and issue to subcontractors prior to formal punch list issued by DESIGN TEAM. CMAR to ensure completion of CMAR's initial punch list prior to DESIGN TEAM's punch list walk through.
  - Work cooperatively with the Project team to develop and implement an effective commissioning plan.

## SAFETY

- Implement a formal project safety plan.
- CMAR to designate on-site safety point of contact.
- CMAR to coordinate jobsite Safety Talks as may be necessary.
- Inform City of any inspections or incidents.

## PROJECT CLOSEOUT

- Timely submission of operation and maintenance manuals and completed punch lists, coordination of training, submission of as-built field documents, and financial close-out of project. CMAR to actively support and participate in the commissioning activities.
- Upon completion of construction the DESIGN TEAM and CMAR team will prepare and deliver one set of as-constructed record drawings and specifications in an electronic format acceptable to the City, incorporating revisions made by the DESIGN TEAM during the construction phase and field changes noted on the CMAR's marked up field set.

## OTHER

- Assist City in working with various governing authorities as requested.
- Work with the Project Team to develop a communication system that is effective for the participants and meets the schedule requirements of the project.
- CMAR will meet all standard City requirements, including licensures and insurance.

## RFP SCHEDULE

Activities & Deliveries	Dates
RFP Solicitation	Tuesday, September 30 <sup>th</sup> , 2025
RFP Submission Due	Thursday, October 9 <sup>th</sup> , 2025, by 3pm
Interviews	Afternoon of Oct. 13 <sup>th</sup> , 2025
Public Works Committee Recommendation to City Council	October 21 <sup>st</sup> , 2025
City Council Contract Approval	October 28 <sup>th</sup> , 2025
Start of Services	Early November 2025
End of Construction	June 2026 (Grand Opening July 4 <sup>th</sup> )

## SUBMISSION REQUIREMENTS

**The proposal and interview presentation should be a demonstration of the firm's ability to communicate concisely and succinctly.** Submissions are to be organized in the same sequence as outlined below. Limit electronic proposal response to ten (10) single-sided printable sheets, minimum font size of 11 point (excludes transmittal cover letter). **Failure to include requested information, or follow the organizational requirements outlined above, will have a negative impact on the evaluation of the proposal. The minimum contents of a proposal are as follows.**

Six (6) bound copies to be brought to the interview. Electronic copy to be submitted on October 9<sup>th</sup>, 2025, by 3 pm to the contacts below.

Electronic Copies to:

Mariah Albrecht: [malbrecht@ci.ramsey.mn.us](mailto:malbrecht@ci.ramsey.mn.us)

Chuck Evens: [cevens@damonfarber.com](mailto:cevens@damonfarber.com)

## COMMUNICATIONS

- Provide a brief description of your communications plan for the project.
- Indicate how your firm will communicate with the project team and to overall stakeholders in the project.

## SCHEDULE

- Describe key items that will be critical to keeping this project on schedule.
- Provide a list of equipment or materials that may require early procurement.
- Outline steps within your schedule that will ensure the park will be open and operational by July 1<sup>st</sup>, 2026.
- Indicate any items of concern that may cause delays to your outline.
- Provide an outline of how you would be able to accomplish this in the short timeframe allowed.

## SITE LOGISTICS / DISRUPTION AVOIDANCE

- Provide a site layout plan which shows laydown and storage areas, construction trailers, dumpsters, parking, and construction traffic flow.
- Describe your disruption avoidance plan for all stages of the project.

## EVALUATION CRITERIA & PROCEDURES

### SELECTION TEAM & INTERVIEWS

A City selected evaluation panel will rate respondents for this work using only objective criteria based upon the information obtained from the Proposals and your interview. The proposed project manager and personnel will be requested to represent the firm at the interviews. The City intends to conduct in-person interviews, but may consider teleconference interviews at their discretion.

## SELECTION CRITERIA

The evaluation will consist of a matrix of requirements, qualifications, and experience. The following criteria will be used in evaluating firms for final selection:

<b>Required Component</b>	<b>A strong proposal will:</b>	<b>Weight</b>
<i>Cover Letter</i> (Required but not scored)	Clearly summarize the key elements of proposal and outline why your firm should be selected to provide the CMAR service.	0%
	Nominal 'points' provided for firms that have provided demonstrable assistance during the project development prior to issuance of this RFP	5%
<i>Communications</i>	Outline your firm's communication plan for this project.  Your plan should include communication with the project team, Ramsey website updates, as well as the public.	5%
<i>Schedule</i>	Describe the steps required to complete this project on time. Provide a list of any equipment or materials that early procurement will be required.  <b>Demonstrated ability to deliver a quality project for public use on or before July 1<sup>st</sup> 2026.</b>	35%
<i>Site Logistics/ Disruption Avoidance</i>	Provide a site plan showing laydown and storage areas, construction trailers, dumpsters, parking, and construction traffic flow.  Describe how your firm will limit disruption throughout the duration of this project.	5%
<i>Interviews</i>	Interviews will be 45 minutes long with 20 minutes for presentation and 25 minutes for question and answers.	50%

## CONDITIONS OF REQUEST AND REQUIREMENTS

### MINIMUM REQUIREMENTS

Consideration of a prospective consultant's (firm's) proposals will be made only if the prospective consultant meets requirements of this RFP. The City reserves the right to adjust, increase, limit, suspend or rescind the rating based on subsequently learned information. The City reserves the right to award a contract to the firm that presents the best proposal and which will best accomplish the desired results for the city.

### REQUEST FOR SUPPLEMENTAL INFORMATION

The City reserves the right to require, from any or all consultants (firms), supplemental information that clarifies submitted materials.

### QUESTIONS

All questions regarding this solicitation should be directed to the City representative listed in this RFP. Do not attempt to contact other City staff members regarding your proposal or any related submittal.

### INCOMPLETE PROPOSALS

Incomplete and/or unsigned proposals will not be considered. However, if a submission is incomplete, and if it appears that the omission can be corrected promptly, the affected firm may be contacted and offered the opportunity to complete the proposal and provide the required information within a prescribed period of time, which will not be extended. If a firm does not respond within the time stated, the Proposal will not be considered.

### REJECTION OF SUBMITTED RFP

Proposals that are not current, accurate, and/or completed accurately in accordance with the prescribed format shall be considered non-responsive and eliminated from further consideration.

### SELECTION PROCESS TERMINATION

The City reserves the right to terminate the selection process, at any time, without making an award to any and all consultants.

### DISQUALIFICATION

Factors such as, but not limited to, any of the following may be considered just cause to disqualify proposals without further consideration:

- Any attempt to improperly influence any member of the selection staff.
- Existence of any lawsuit, unresolved contractual claim or dispute between consultant and the City.

- Evidence of consultant’s inability to successfully complete the responsibilities and obligations of the proposals; and Consultant’s default under any agreement, which results in termination of the agreement.
- Any consultant (firm) deemed not qualified, or consultants (firms) who’s rating changes sufficiently to disqualify them, will be notified in writing. No consultant shall have the right to an appeal based upon an incomplete or late submission.





Complex Projects Solved

PROPOSAL

OCTOBER 9, 2025

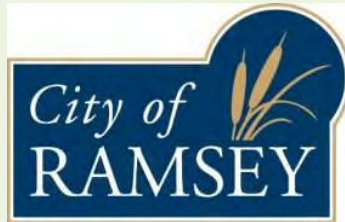

PROPOSAL FOR CONSTRUCTION MANAGEMENT AT RISK SERVICES

## CITY OF RAMSEY THE WATERFRONT WATERPLAY

City of Ramsey  
Mariah Albrecht, Parks Administrative Assistant  
14199 Jasper Street  
Ramsey, MN 55303  
Mariah Albrecht: [malbrecht@ci.ramsey.mn.us](mailto:malbrecht@ci.ramsey.mn.us)  
Chuck Evens: [cevens@damonfarber.com](mailto:cevens@damonfarber.com)



October 9, 2025

## City of Ramsey

Mariah Albrecht, Parks Administrative Assistant  
14199 Jasper Street  
Ramsey, MN 55303  
Mariah Albrecht: malbrecht@ci.ramsey.mn.us  
Chuck Evens: cevens@damonfarber.com

**RE: PROPOSAL FOR CONSTRUCTION MANAGEMENT AT RISK SERVICES FOR THE CITY OF RAMSEY  
THE WATERFRONT WATERPLAY**

## Dear City of Ramsey Selection Committee:

Thank you for the opportunity to propose as your Construction Manager at Risk (CMAR) for the Waterfront! Our team and I are excited at the opportunity to serve the City of Ramsey on a project that touches on so many of our firm's strengths. We're also excited to continue working alongside Damon Farber Landscape Architects as we've done on several similar projects including Ridgedale Commons, Water Works and Loring Green.

H+U Construction (H+U) has been serving Minnesota cities since 1983, and has since built or improved more than 25,000,000 square feet of public space as a Construction Manager; including numerous award-winning parks and recreation facilities. Below are several additional reasons why we believe H+U is the best partner for this project:

- + **This is What We Do:** Nearly all of our work is completed as a Construction Manager for public agencies. We've successfully completed 500+ multi-million dollar public projects as a Construction Manager; with more than 91% of our clients choosing to become repeat clients over the past 10-years.
- + **Right Sized Firm:** Working with a mid-sized firm, you can expect that the improved Waterfront will receive close personal attention from our leadership, including having a consistent presence on site.
- + **Parks and Recreation Experience:** We have decades of experience with parks and recreation projects including park buildings, site improvements, water and play features, gathering spaces, restrooms, and more, including ongoing projects with Damon Farber.
- + **Continued Commitment:** We appreciate the trust our clients have in us and take pride in the work we do. If selected as your CMAR, H+U Construction will remain committed to the project, community, and your satisfaction for decades to come.

Thank you again for the opportunity to serve the City of Ramsey. I hope to meet with you soon, and look forward to responding to any questions you may have.

Respectfully,

A handwritten signature in black ink, appearing to read 'Joe Uhlhorn'.

Joe Uhlhorn, Project Executive  
H+U Construction  
Phone: 651 335 4634  
Email: juhlhorn@hu-construction.com



# TABLE OF CONTENTS

COVER LETTER

1. COMMUNICATIONS 1-2

2. SCHEDULE 3-6

3. SITE LOGISTICS +  
DISRUPTION AVOIDANCE 7-8



Complex Projects Solved

# PROPOSAL

MISSISSIPPI GATEWAY REGIONAL PARK  
MINI-MISSISSIPPI WATER PLAY AREA  
New Construction + Site Improvements



# 1. COMMUNICATIONS



Our **teamwork philosophy** spreads far beyond our office walls.

## • Provide a brief description of your communications plan for the project.

Our proposed team members have positive working relationships with every design firm involved in the Waterfront Park project, including Damon Farber Landscape Architects, Rehder & Associates, Nelson-Rudie & Associates, and Aquatic Design Solutions; each of whom can attest to our ability to communicate proactively, efficiently, and thoroughly.

H+U's standard communications matrix is contained within our Procore software, and will be tailored to reflect any changes desired by the City or design team. Documents, once posted to Procore, will be automatically routed to the pre-determined team members for review, approval, or as updates. Our team will also maintain schedules, budgets, pictures, daily logs, and much more within Procore, to document and communicate progress on a daily basis.

We expect that our team member(s) will attend all design phase meetings and that our staff will facilitate all construction phase meetings so that we can communicate obstacles, opportunities, costs, and schedule impacts in real time, or as close to real time as possible. This high level of involvement will help foster team work and encourage open dialog between all project team members.

Effective communication is essential for the success of the Waterfront Park project. Our communication plan will establish the methods, frequency, and responsibilities for communication among all project stakeholders to:

- + Promote collaboration and transparency
- + Facilitate timely decision-making
- + Ensure accurate dissemination of project information
- + Maintain public confidence and awareness
- + Document communications for accountability and record-keeping

## Communication Principles

- + **Clarity:** All communications will be clear, concise, and consistent.
- + **Timeliness:** Information will be shared promptly to prevent delays.
- + **Transparency:** The City and community will be kept informed of key milestones and impacts.
- + **Accessibility:** Project information will be easy to access and understand for all audiences.
- + **Documentation:** All official communications will be recorded and archived.

**Public Communication:** H+U will support the City in keeping the community informed and engaged by offering the following resources:

- + **Dedicated Project Webpage:** Hosted by the City with updates from H+U (photos, milestones, upcoming impacts).
- + **Public Signage:** Display project information, contacts, and anticipated completion dates.
- + **Social Media Updates:** Coordinated with the City's communications team.
- + **Press Releases:** Jointly prepared by City and H+U for major milestones.
- + **Public Inquiries:** Directed to a designated City representative, with input from H+U as needed.



# 1. COMMUNICATIONS

• Indicate how your firm will communicate with the project team and to overall stakeholders in the project.

H+U will actively engage with the City of Ramsey and D/F design team on a daily basis during construction, to communicate project information with project stakeholders including nearby businesses, neighborhood residents, and City departments. H+U will also be available to present to various groups including the City Council when requested. Considering the expedited nature of this project, we expect to provide the City with weekly construction updates as opposed to the more typical monthly updates that longer duration projects often receive. These updates will document the work performed with photos, provide schedule updates, outline upcoming work, and provide other information that may be requested for distribution to the wider Ramsey community via the City website or other means.

The City will be served by the team members shown below; all of whom have completed park projects working alongside Damon Farber within the past 2-years:

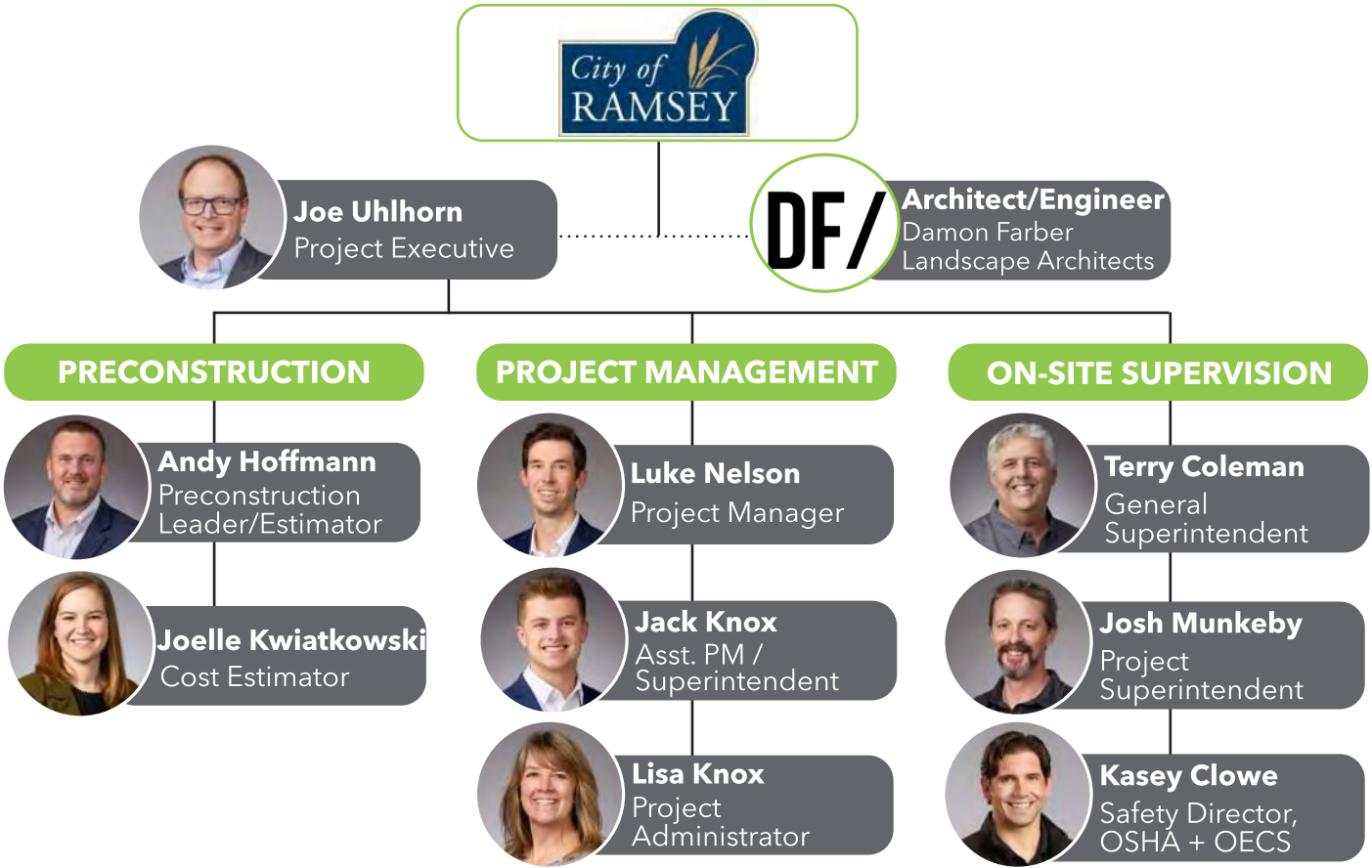

H+U’s proposed team members have been completing complex projects together for as many as 15 years, and are all currently working on several relevant park improvement projects. Our proposed team will be led by our firm’s partners, Project Executive/Partner, Joe Uhlhorn and Preconstruction Leader/Partner, Andy Hoffmann. Joe will be heavily involved and will serve as the City’s main contact at all phases of design and construction while overseeing the performance of our team, community engagement, public presentations, and holding subcontractors accountable for meeting the schedule.

H+U’s proposed Project Manager (Luke Nelson) and Supervision team (Terry Coleman and Josh Munkeby) will be engaged during the preconstruction phase, and provide day-to-day management of the project and site during construction. Luke will primarily be responsible for budget management, contract enforcement, and overseeing administrative team members. Terry will be regular fixture on-site while Josh will be stationed on-site full-time during construction with the possibility of additional off-hour or weekend supervision being provided by additional team members. Our supervision team will serve as the City’s “eyes and ears” during construction while being responsible for enforcing health and safety requirements, providing quality assurance, managing the schedule, coordinating subcontractors, and managing site logistics.

Complex Projects Solved

# PROPOSAL

2. SCHEDULE

## WATER WORKS

Historical Renovation

7,000/SF Building + 3 Acres of Green Space





**500+ Multi-million-dollar projects completed on-schedule + on-budget.**

- **Describe key items that will be critical to keeping this project on schedule.**

We understand that the City will or has already begun early procurement of the Romtec bathroom building and Poligon shelters. Our schedule shows us installing the foundations for these buildings shortly after bidding (Feb 2026) so we will need to work with the City, design team, and the vendor to obtain approved foundation designs before we award concrete work in the January bid event.

We also understand that the City has already procured a utility contractor to install the new sanitary and water service to the site. We assume this work will be completed in 2025. We strongly advise, and show in our schedule, early procurement of a grading contractor to complete the mass grading on the site in 2025. The best scenario would be to award this work in late October and have it completed in November or early December 2025.

Power to the site will need to be provided by new electrical service and a new transformer. This should be coordinated with Connexus Energy as soon as the electrical load for the site is determined - hopefully November 2025. Other electrical components that we need to monitor lead times on and may need to procure early are switchgear and light fixtures.

The precast bridge on the SE side of the site will require shop drawings and coordination with the concrete paving. These shop drawings need to be approved by March 1, the footings for the bridge installed in early April, and the precast released for production by the middle of April.

Site amenities, and site furniture will need to be ordered by April 1st to ensure they are delivered to the site in time for installation in late June.

We assume some coordination has already begun on permitting the work. Plan reviews with the City of Ramsey and potentially the State of MN (plumbing) need to be completed as soon as possible. All permitting activities need to be pushed on this project to ensure they do not create a delay.

Our schedule shows approval of the GMP at the January 27, 2026 City Council meeting. Approving the project's costs at that meeting allows H+U to complete subcontracting for the work and get started on construction related submittals, as well as foundation work for the shelters.

- **Provide a list of equipment or materials that may require early procurement.**

We have outlined suggested equipment and materials for early procurement on page 6.

- **Outline steps within your schedule that will ensure the park will be open and operational by July 1st, 2026.**

Please see our schedule and considerations on the following pages outlining steps to ensure the park will be open and operational by July 1, 2026.

# 2. SCHEDULE

• Provide an outline of how you would be able to accomplish this in the short timeframe allowed.

The Waterfront Waterplay													
ID	Task Name	Duration	Start	Finish									
1	<b>THE WATERFRONT WATERPLAY</b>												
2	Notice To Proceed	0 days	Tue 10/28/25	Tue 10/28/25									
3	Kick Off Meeting - Project Confirmations	1 day	Wed 10/29/25	Wed 10/29/25									
4	Budget Confirmation	5 days	Thu 10/30/25	Wed 11/5/25									
5	Complete DD/CD Design	35 days	Thu 10/9/25	Wed 11/26/25									
6	Complete Final Estimate	10 days	Thu 11/27/25	Wed 12/10/25									
7	Bidding Front Ends	5 days	Thu 12/11/25	Wed 12/17/25									
8	Bid Window	20 days	Thu 12/18/25	Wed 1/14/26									
9	GMP Development and Approval	9 days	Thu 1/15/26	Tue 1/27/26									
10	<b>Procurement (Long Lead Items)</b>												
11	Transformer	120 days	Mon 12/1/25	Fri 5/15/26									
12	400A Switch Gear	120 days	Mon 12/1/25	Fri 5/15/26									
13	Aquatic Equipment	100 days	Mon 12/1/25	Fri 4/17/26									
14	<b>Construction</b>												
15	Underground utilities - sanitary sewer & water main (installed fall 2025) Transformer ordered	25 days	Mon 10/13/25	Fri 11/14/25									
16	Earthwork and grading (Needs to be done Fall 2025)	15 days	Mon 11/10/25	Fri 11/28/25									
17	Rip Frost and Pour Footings	40 days	Mon 2/2/26	Fri 3/27/26									
18	900 sf park support building	30 days	Mon 3/30/26	Fri 5/8/26									
19	Underground drain tile and storm sewer for site drainage	10 days	Wed 4/1/26	Tue 4/14/26									
20	MEP and Aquatic Piping	25 days	Wed 4/15/26	Tue 5/19/26									
21	Site Lighting and Amenity Foundations	8 days	Fri 5/15/26	Tue 5/26/26									
22	Qty 3 - 384 sf shade pavilions	5 days	Wed 6/10/26	Tue 6/16/26									
23	17,000 sf of decorative concrete paving	15 days	Wed 5/20/26	Tue 6/9/26									
24	Metal guard rails	3 days	Wed 6/10/26	Fri 6/12/26									
25	Flagstone Paving	15 days	Fri 6/5/26	Thu 6/25/26									
26	10-15 permanent fabric shade umbrellas	3 days	Wed 6/10/26	Fri 6/12/26									
27	145 tons of natural stone	5 days	Wed 6/10/26	Tue 6/16/26									
28	Irrigation and irrigation pump station with pond intake	10 days	Wed 6/10/26	Tue 6/23/26									
29	150 lf of aluminum fencing	5 days	Wed 6/10/26	Tue 6/16/26									
30	3,000 sf of synthetic turf	5 days	Wed 6/24/26	Tue 6/30/26									
31	Landscape plantings and Site Amenities	5 days	Wed 6/24/26	Tue 6/30/26									



We believe construction projects are **far greater** than the sum of their parts.

- **Indicate any items of concern that may cause delays to your outline.**

Our key project team members compiled the schedule on the previous page, showing a path to completion on July 1st, 2026. While designs are not yet complete, materials have not all been selected, and other forces outside of our control could impact the schedule, we believe that we have prepared an aggressive but achievable logic-based schedule. Meeting this schedule will require an engaged owner, responsive design partners, committed subcontractors, and aggressive schedule management. Several considerations for this schedule and accommodations include the following:

- + **Utility + Rough Grading:** We believe it will be necessary to have the site graded, and to have sewer and water utilities installed before winter. Since utility work is already slated to start in October and be completed this fall, it may be cost effective to have the same contractor complete rough grading at the same time. We believe the cost of this work will be less than \$175,000, allowing the work to be procured without public bidding.
- + **Early Procurement:** Immediately upon selection, our team would request City approval to procure a 400 amp switchgear and work with Connexus Energy to procure the new Transformer. These materials can carry very long lead times and will need to be purchased before the GMP is submitted. Switchgear may be purchased most efficiently using the State's Sourcwell contract.
- + **Early Start:** Our schedule requires ground thawing and frost ripping to install concrete foundations this winter since these foundations must be installed before sub-grade MEP and aquatic piping can be installed. H+U has frost blankets available for the project, and with City approval, would install them in late November once the rough grading is completed, in order to maintain frost at a more manageable depth to help expedite foundation excavation and allow it to be completed more efficiently.
- + **Road Restrictions:** All heavy equipment, specifically excavation equipment, must be delivered to and stored at the site before road restrictions come into effect; typically in late February or early March. Our schedule has us starting foundation excavation in early February, immediately after the GMP is approved on January 27th. This makes the GMP approval date critical to the overall schedule, as a 2-3 week delay in approval could jeopardize our ability to bring equipment to the site and start on schedule.
- + **On-Site Storage:** We want to encourage subcontractors to deliver materials to the site as early as possible to ensure that materials are readily available when needed. To accommodate this and because there is ample land adjacent to the park, we propose to provide secure Conex storage boxes on site for subcontractor use.
- + **Design Team Considerations:** We would like to review final specifications as early as possible, so that our team has an opportunity to identify schedule impacts and request changes as necessary. Specifications sometimes include things like a 3-week green up period before plantings can be installed and lengthy timelines for plantings establishment, which we would request be waived in consideration of the completion date.



Progress through **collaboration.**

- + **Material Selections:** Some materials included in the design may need to be modified to accommodate the construction schedule. Our team expects to be engaged in the design process to identify these materials in real-time and to find timely alternatives as needed. We've already identified several materials that we'd like to revise, either to maintain the schedule or improve the finished product, as follows:
  1. Plans show a precast bridge on sheet L120 (noted as AM-03). Precast bridges carry long lead times and their precise dimensions are often field verified before fabrication begins, which our schedule cannot accommodate. We recommend revising the bridge to be timber or a prefabricated assembly to ensure materials can be delivered on schedule.
  2. Plans call for Turf Grass across the site, which we would recommend confirming is intended to be sod and not seed. This will help expedite the turf establishment after the project is completed and reduce the likelihood that park patrons and pedestrian traffic will damage the turf before can be established.
  3. Plan sheet L110 shows fairly extensive pavers (noted as P-05) surrounding decorative concrete. Pavers can be expensive and are very time consuming to install when compared to decorative concrete. We would recommend changing these pavers to decorative concrete to expedite the schedule and reduce the construction cost.
  4. Decorative concrete types P-01 through P-04 call for fiber reinforcement, which we would recommend changing to wire mesh reinforcement. While it is faster to install fiber reinforcement, the fibers can protrude from the concrete and are not appealing to walk on with bare feet. Considering the combined play and water elements included in this project, fiber reinforcement may not be the best product to use here.



### WHY H+U?

What makes H+U Construction different from our competition? It's our people, their commitment to a job well done, their dedication to our clients, and the determination to be the best they can be through continuous learning and refinement of their skills in Construction Management.

Our teamwork philosophy spreads far beyond our office walls and runs deep between our collaborative work with all our partners, clients, architects, engineers, contractors, communities and owners we work with - resulting in strong, long-lasting relationships.

Complex Projects Solved

# PROPOSAL

BRYANT PARK  
Renovations + Site Improvements

3. SITE LOGISTICS +  
DISRUPTION AVOIDANCE



### 3. SITE LOGISTICS + DISRUPTION AVOIDANCE

- Provide a site layout plan which shows laydown and storage areas, construction trailers, dumpsters, parking, and construction traffic flow.

Our team prepared the staging and site utilization plan below, which shows site boundaries (temp. fencing) and site access points in red, the work area in green, and laydown area in blue. This plan is conceptual and will be refined throughout the design process, but accounts for new utility locations, places the field office trailer north of the site near the new transformer with clear views of the site and adjacent parking, keeps subcontractor parking away from residential buildings, and takes advantage of city-owned land south and west of the site to serve as a laydown and unloading area which will help preserve the newly installed sidewalks and parking areas.



### 3. SITE LOGISTICS + DISRUPTION AVOIDANCE



H+U projects have had zero willful citations or lost time injuries in over 5-years.

- Describe your disruption avoidance plan for all stages of the project.

Disruption Avoidance Plans (DAP) are a large part of nearly every project H+U takes on, and it is always our goal to be a “good neighbor”. We do not expect that the project will disrupt utility service to the neighboring properties or require street closures, but there are still disruptions that we need to minimize and communicate, including:

- + **Night and/or Weekend Work:** Given the expedited schedule, it is likely that crews will need to work extended days and/or on weekends to expedite the project. Our team was unable to find city ordinances restricting work hours, but if there are ordinances that restrict work, we would like to discuss a temporary variance allowing crews to work up to 12-hour days M-F, and between the hours of 8:00 and 4:00 on occasional weekends. In the event that a variance is granted, H+U will prepare signage and marketing materials to be posted at the site and delivered to neighboring buildings explaining the specific days, hours, and activities that will be taking place on site.
- + **Construction Noise:** Deliveries and heavy equipment operating hours will be restricted to Monday through Friday between the hours of 8:00 am and 4:00 pm in order to limit the noise generated by the project and to be a good neighbor. Our Superintendent will enforce these hours, which will also be discussed at every construction meeting and documented in meeting minutes.
- + **Dust Protection:** Any soils that are exposed to the elements for short periods will be misted with water to minimize dust. Soils left exposed for longer periods will be seeded.
- + **Parking Lot Closure:** Our current site plan shows the small parking lot east of the site being restricted for subcontractor parking, which would also serve as a site access point for large equipment such as truck cranes, cement trucks, tree spade trucks, boulder deliveries, etc. This closure will be advertised with signage in advance, and directional signage will also be provided directing drivers to other on-street parking areas near the park.

- + **Short-term Sidewalk Closures:** We intend to maintain pedestrian access to the sidewalk along Center Street during construction, but there will be times when it will be obstructed to allow materials and equipment to access the site by crossing the sidewalk. Our staff will post signage along the sidewalk notifying pedestrians of dates when the sidewalk may be obstructed for several minutes at a time throughout the day, and if necessary, can provide staff to direct vehicles and pedestrians at times.
- + **Stormwater Pollution Protection:** A stormwater pollution protection plan (SWPPP) and SWPPP Permit will be required for the project, and is especially important considering the sites proximity to the neighboring pond. H+U will provide SWPPP monitoring and enforcement including site inspections after rain events and throughout work days, street and sidewalk sweeping, additional silt fence or silt fence repairs, inlet protection, tire wash(s), etc. to ensure compliance with the permit and to help the site appears neat and tidy at all times.
- + **On-Site Supervision:** H+U will provide full-time supervision for the project, with staff on-site at all times when work is being completed. This ensures that there will always be a representative on site to enforce our standards, address concerns, and coordinate deliveries, manage the site, and represent the City’s interests in real-time.



CONSTRUCTION MANAGEMENT + GENERAL CONTRACTING + OWNER REPRESENTATION + CONSTRUCTION CONSULTING

5555 West 78th Street, Suite A / Minneapolis, MN 55439 / T 952 941 0075 / [info@hu-construction.com](mailto:info@hu-construction.com) / [www.hu-construction.com](http://www.hu-construction.com)



# AIA® Document A133® – 2019

## Standard Form of Agreement Between Owner and Construction Manager as Constructor where the basis of payment is the Cost of the Work Plus a Fee with a Guaranteed Maximum Price

**AGREEMENT** made as of the    day of    in the year  
*(In words, indicate day, month, and year.)*

**BETWEEN** the Owner:  
*(Name, legal status, address, and other information)*

City of Ramsey  
14199 Jasper Street  
Ramsey, MN 55303

and the Construction Manager:  
*(Name, legal status, address, and other information)*

Hoffmann+Uhlhorn Construction, Inc. dba H+U Construction  
5555 W 78th Street, Suite A  
Minneapolis, MN 55439

for the following Project:  
*(Name, location, and detailed description)*

Waterfront Park  
Ramsey, MN

The Architect:  
*(Name, legal status, address, and other information)*

Damon Farber Landscape Architects  
310 4th Ave S, Suite 7050  
Minneapolis, MN 55415

### ADDITIONS AND DELETIONS:

The author of this document has added information needed for its completion. The author may also have revised the text of the original AIA standard form. An *Additions and Deletions Report* that notes added information as well as revisions to the standard form text is available from the author and should be reviewed. A vertical line in the left margin of this document indicates where the author has added necessary information and where the author has added to or deleted from the original AIA text.

This document has important legal consequences. Consultation with an attorney is encouraged with respect to its completion or modification.

AIA Document A201™–2017, General Conditions of the Contract for Construction, is adopted in this document by reference. Do not use with other general conditions unless this document is modified.

The Owner and Construction Manager agree as follows.

Init.

/

AIA Document A133 – 2019. Copyright © 1991, 2003, 2009, and 2019. All rights reserved. "The American Institute of Architects," "American Institute of Architects," "AIA," the AIA Logo, and "AIA Contract Documents" are trademarks of The American Institute of Architects. This document was produced at 10:24:29 ET on 10/16/2025 under Order No.4104243742 which expires on 12/31/2025, is not for resale, is licensed for one-time use only, and may only be used in accordance with the AIA Contract Documents® Terms of Service. To report copyright violations, e-mail docinfo@aiacontracts.com.

User Notes:

(846025776)

## TABLE OF ARTICLES

1	INITIAL INFORMATION
2	GENERAL PROVISIONS
3	CONSTRUCTION MANAGER'S RESPONSIBILITIES
4	OWNER'S RESPONSIBILITIES
5	COMPENSATION AND PAYMENTS FOR PRECONSTRUCTION PHASE SERVICES
6	COMPENSATION FOR CONSTRUCTION PHASE SERVICES
7	COST OF THE WORK FOR CONSTRUCTION PHASE
8	DISCOUNTS, REBATES, AND REFUNDS
9	SUBCONTRACTS AND OTHER AGREEMENTS
10	ACCOUNTING RECORDS
11	PAYMENTS FOR CONSTRUCTION PHASE SERVICES
12	DISPUTE RESOLUTION
13	TERMINATION OR SUSPENSION
14	MISCELLANEOUS PROVISIONS
15	SCOPE OF THE AGREEMENT

### EXHIBIT A GUARANTEED MAXIMUM PRICE AMENDMENT

### EXHIBIT B INSURANCE AND BONDS

## ARTICLE 1 INITIAL INFORMATION

§ 1.1 This Agreement is based on the Initial Information set forth in this Section 1.1.

*(For each item in this section, insert the information or a statement such as "not applicable" or "unknown at time of execution.")*

§ 1.1.1 The Owner's program for the Project, as described in Section 4.1.1:

*(Insert the Owner's program, identify documentation that establishes the Owner's program, or state the manner in which the program will be developed.)*

§ 1.1.2 The Project's physical characteristics:

*(Identify or describe pertinent information about the Project's physical characteristics, such as size; location; dimensions; geotechnical reports; site boundaries; topographic surveys; traffic and utility studies; availability of public and private utilities and services; legal description of the site, etc.)*

§ 1.1.3 The Owner's budget for the Guaranteed Maximum Price, as defined in Article 6:

*(Provide total and, if known, a line item breakdown.)*

§ 1.1.4 The Owner’s anticipated design and construction milestone dates:

- .1 Design phase milestone dates, if any:
- .2 Construction commencement date:
- .3 Substantial Completion date or dates:  
June 30, 2026
- .4 Other milestone dates:

§ 1.1.5 The Owner’s requirements for accelerated or fast-track scheduling, or phased construction, are set forth below:  
*(Identify any requirements for fast-track scheduling or phased construction.)*

The project must be complete and open to the public by June 30, 2026

§ 1.1.6 The Owner’s anticipated Sustainable Objective for the Project:  
*(Identify and describe the Owner’s Sustainable Objective for the Project, if any.)*

§ 1.1.6.1 If the Owner identifies a Sustainable Objective, the Owner and Construction Manager shall complete and incorporate AIA Document E234™–2019, Sustainable Projects Exhibit, Construction Manager as Constructor Edition, into this Agreement to define the terms, conditions and services related to the Owner’s Sustainable Objective. If E234–2019 is incorporated into this agreement, the Owner and Construction Manager shall incorporate the completed E234–2019 into the agreements with the consultants and contractors performing services or Work in any way associated with the Sustainable Objective.

§ 1.1.7 Other Project information:  
*(Identify special characteristics or needs of the Project not provided elsewhere.)*

§ 1.1.8 The Owner identifies the following representative in accordance with Section 4.2:  
*(List name, address, and other contact information.)*

Mark Riverblood  
Parks and Assistant Public Works Director  
14199 Jasper Street  
Ramsey, MN 55303  
mriverblood@ci.ramsey.mn.us  
763-238-1733

§ 1.1.9 The persons or entities, in addition to the Owner’s representative, who are required to review the Construction Manager’s submittals to the Owner are as follows:

Init.  
/

*(List name, address and other contact information.)*

**§ 1.1.10** The Owner shall retain the following consultants and contractors:  
*(List name, legal status, address, and other contact information.)*

**.1** Geotechnical Engineer:

Braun Intertec

**.2** Civil Engineer:

**.3** Other, if any:

*(List any other consultants retained by the Owner, such as a Project or Program Manager.)*

**§ 1.1.11** The Architect's representative:  
*(List name, address, and other contact information.)*

Chuck Evans, PLA  
Associate Principal  
310 S 4th Street, Suite 7050  
Minneapolis, MN 55415  
cevens@damonfarber.com  
651-216-6115

**§ 1.1.12** The Construction Manager identifies the following representative in accordance with Article 3:  
*(List name, address, and other contact information.)*

Joe Uhlhorn  
Project Executive + Partner  
5555 W 78th Street, Suite A  
Minneapolis, MN 55439  
juhlhorn@hu-construction.com  
651-335-4634

§ 1.1.13 The Owner's requirements for the Construction Manager's staffing plan for Preconstruction Services, as required under Section 3.1.9:  
*(List any Owner-specific requirements to be included in the staffing plan.)*

§ 1.1.14 The Owner's requirements for subcontractor procurement for the performance of the Work:  
*(List any Owner-specific requirements for subcontractor procurement.)*

§ 1.1.15 Other Initial Information on which this Agreement is based:

§ 1.2 The Owner and Construction Manager may rely on the Initial Information. Both parties, however, recognize that such information may materially change and, in that event, the Owner and the Construction Manager shall appropriately adjust the Project schedule, the Construction Manager's services, and the Construction Manager's compensation. The Owner shall adjust the Owner's budget for the Guaranteed Maximum Price and the Owner's anticipated design and construction milestones, as necessary, to accommodate material changes in the Initial Information.

§ 1.3 Neither the Owner's nor the Construction Manager's representative shall be changed without ten days' prior notice to the other party.

## **ARTICLE 2 GENERAL PROVISIONS**

### **§ 2.1 The Contract Documents**

The Contract Documents consist of this Agreement, Conditions of the Contract (General, Supplementary and other Conditions), Drawings, Specifications, Addenda issued prior to execution of this Agreement, other documents listed in this Agreement, and Modifications issued after execution of this Agreement, all of which form the Contract and are as fully a part of the Contract as if attached to this Agreement or repeated herein. Upon the Owner's acceptance of the Construction Manager's Guaranteed Maximum Price proposal, the Contract Documents will also include the documents described in Section 3.2.3 and identified in the Guaranteed Maximum Price Amendment and revisions prepared by the Architect and furnished by the Owner as described in Section 3.2.8. The Contract represents the entire and integrated agreement between the parties hereto and supersedes prior negotiations, representations or agreements, either written or oral. If anything in the other Contract Documents, other than a Modification, is inconsistent with this Agreement, this Agreement shall govern. An enumeration of the Contract Documents, other than a Modification, appears in Article 15.

### **§ 2.2 Relationship of the Parties**

The Construction Manager accepts the relationship of trust and confidence established by this Agreement and covenants with the Owner to cooperate with the Architect and exercise the Construction Manager's skill and judgment in furthering the interests of the Owner to furnish efficient construction administration, management services, and supervision; to furnish at all times an adequate supply of workers and materials; and to perform the Work in an expeditious and economical manner consistent with the Owner's interests. The Owner agrees to furnish or approve, in a timely manner, information required by the Construction Manager and to make payments to the Construction Manager in accordance with the requirements of the Contract Documents.

### **§ 2.3 General Conditions**

§ 2.3.1 For the Preconstruction Phase, AIA Document A201™–2017, General Conditions of the Contract for Construction, shall apply as follows: Section 1.5, Ownership and Use of Documents; Section 1.7, Digital Data Use and Transmission; Section 1.8, Building Information Model Use and Reliance; Section 2.2.4, Confidential Information; Section 3.12.10, Professional Services; Section 10.3, Hazardous Materials; Section 13.1, Governing Law. The term "Contractor" as used in A201–2017 shall mean the Construction Manager.

§ 2.3.2 For the Construction Phase, the general conditions of the contract shall be as set forth in A201–2017, which document is incorporated herein by reference. The term "Contractor" as used in A201–2017 shall mean the Construction Manager.

## **ARTICLE 3 CONSTRUCTION MANAGER'S RESPONSIBILITIES**

The Construction Manager's Preconstruction Phase responsibilities are set forth in Sections 3.1 and 3.2, and in the applicable provisions of A201-2017 referenced in Section 2.3.1. The Construction Manager's Construction Phase responsibilities are set forth in Section 3.3. The Owner and Construction Manager may agree, in consultation with the Architect, for the Construction Phase to commence prior to completion of the Preconstruction Phase, in which case, both phases will proceed concurrently. The Construction Manager shall identify a representative authorized to act on behalf of the Construction Manager with respect to the Project.

### **§ 3.1 Preconstruction Phase**

#### **§ 3.1.1 Extent of Responsibility**

The Construction Manager shall exercise reasonable care in performing its Preconstruction Services. The Owner and Architect shall be entitled to rely on, and shall not be responsible for, the accuracy, completeness, and timeliness of services and information furnished by the Construction Manager. The Construction Manager, however, does not warrant or guarantee estimates and schedules except as may be included as part of the Guaranteed Maximum Price. The Construction Manager is not required to ascertain that the Drawings and Specifications are in accordance with applicable laws, statutes, ordinances, codes, rules and regulations, or lawful orders of public authorities, but the Construction Manager shall promptly report to the Architect and Owner any nonconformity discovered by or made known to the Construction Manager as a request for information in such form as the Architect may require.

**§ 3.1.2** The Construction Manager shall provide a preliminary evaluation of the Owner's program, schedule and construction budget requirements, each in terms of the other.

#### **§ 3.1.3 Consultation**

**§ 3.1.3.1** The Construction Manager shall schedule and conduct meetings with the Architect and Owner to discuss such matters as procedures, progress, coordination, and scheduling of the Work.

**§ 3.1.3.2** The Construction Manager shall advise the Owner and Architect on proposed site use and improvements, selection of materials, building systems, and equipment. The Construction Manager shall also provide recommendations to the Owner and Architect, consistent with the Project requirements, on constructability; availability of materials and labor; time requirements for procurement, installation and construction; prefabrication; and factors related to construction cost including, but not limited to, costs of alternative designs or materials, preliminary budgets, life-cycle data, and possible cost reductions. The Construction Manager shall consult with the Architect regarding professional services to be provided by the Construction Manager during the Construction Phase.

**§ 3.1.3.3** The Construction Manager shall assist the Owner and Architect in establishing written protocols for the development, use, transmission, reliance, and exchange of digital data, including building information models for the Project.

#### **§ 3.1.4 Project Schedule**

When Project requirements in Section 4.1.1 have been sufficiently identified, the Construction Manager shall prepare and periodically update a Project schedule for the Architect's review and the Owner's acceptance. The Construction Manager shall obtain the Architect's approval for the portion of the Project schedule relating to the performance of the Architect's services. The Project schedule shall coordinate and integrate the Construction Manager's services, the Architect's services, other Owner consultants' services, and the Owner's responsibilities; and identify items that affect the Project's timely completion. The updated Project schedule shall include the following: submission of the Guaranteed Maximum Price proposal; components of the Work; times of commencement and completion required of each Subcontractor; ordering and delivery of products, including those that must be ordered in advance of construction; and the occupancy requirements of the Owner.

#### **§ 3.1.5 Phased Construction**

The Construction Manager, in consultation with the Architect, shall provide recommendations with regard to accelerated or fast-track scheduling, procurement, and sequencing for phased construction. The Construction Manager shall take into consideration cost reductions, cost information, constructability, provisions for temporary facilities, and procurement and construction scheduling issues.

### **§ 3.1.6 Cost Estimates**

**§ 3.1.6.1** Based on the preliminary design and other design criteria prepared by the Architect, the Construction Manager shall prepare, for the Architect's review and the Owner's approval, preliminary estimates of the Cost of the Work or the cost of program requirements using area, volume, or similar conceptual estimating techniques. If the Architect or Construction Manager suggests alternative materials and systems, the Construction Manager shall provide cost evaluations of those alternative materials and systems.

**§ 3.1.6.2** As the Architect progresses with the preparation of the Schematic Design, Design Development and Construction Documents, the Construction Manager shall prepare and update, at appropriate intervals agreed to by the Owner, Construction Manager and Architect, an estimate of the Cost of the Work with increasing detail and refinement. The Construction Manager shall include in the estimate those costs to allow for the further development of the design, price escalation, and market conditions, until such time as the Owner and Construction Manager agree on a Guaranteed Maximum Price for the Work. The estimate shall be provided for the Architect's review and the Owner's approval. The Construction Manager shall inform the Owner and Architect in the event that the estimate of the Cost of the Work exceeds the latest approved Project budget, and make recommendations for corrective action.

**§ 3.1.6.3** If the Architect is providing cost estimating services as a Supplemental Service, and a discrepancy exists between the Construction Manager's cost estimates and the Architect's cost estimates, the Construction Manager and the Architect shall work together to reconcile the cost estimates.

**§ 3.1.7** As the Architect progresses with the preparation of the Schematic Design, Design Development and Construction Documents, the Construction Manager shall consult with the Owner and Architect and make recommendations regarding constructability and schedules, for the Architect's review and the Owner's approval.

**§ 3.1.8** The Construction Manager shall provide recommendations and information to the Owner and Architect regarding equipment, materials, services, and temporary Project facilities.

**§ 3.1.9** The Construction Manager shall provide a staffing plan for Preconstruction Phase services for the Owner's review and approval.

**§ 3.1.10** If the Owner identified a Sustainable Objective in Article 1, the Construction Manager shall fulfill its Preconstruction Phase responsibilities as required in AIA Document E234™–2019, Sustainable Projects Exhibit, Construction Manager as Constructor Edition, attached to this Agreement.

### **§ 3.1.11 Subcontractors and Suppliers**

**§ 3.1.11.1** If the Owner has provided requirements for subcontractor procurement in section 1.1.14, the Construction Manager shall provide a subcontracting plan, addressing the Owner's requirements, for the Owner's review and approval.

**§ 3.1.11.2** The Construction Manager shall develop bidders' interest in the Project.

**§ 3.1.11.3** The processes described in Article 9 shall apply if bid packages will be issued during the Preconstruction Phase.

### **§ 3.1.12 Procurement**

The Construction Manager shall prepare, for the Architect's review and the Owner's acceptance, a procurement schedule for items that must be ordered in advance of construction. The Construction Manager shall expedite and coordinate the ordering and delivery of materials that must be ordered in advance of construction. If the Owner agrees to procure any items prior to the establishment of the Guaranteed Maximum Price, the Owner shall procure the items on terms and conditions acceptable to the Construction Manager. Upon the establishment of the Guaranteed Maximum Price, the Owner shall assign all contracts for these items to the Construction Manager and the Construction Manager shall thereafter accept responsibility for them.

### **§ 3.1.13 Compliance with Laws**

The Construction Manager shall comply with applicable laws, statutes, ordinances, codes, rules and regulations, and lawful orders of public authorities applicable to its performance under this Contract, and with equal employment opportunity programs, and other programs as may be required by governmental and quasi-governmental authorities.

### § 3.1.14 Other Preconstruction Services

Insert a description of any other Preconstruction Phase services to be provided by the Construction Manager, or reference an exhibit attached to this document

*(Describe any other Preconstruction Phase services, such as providing cash flow projections, development of a project information management system, early selection or procurement of subcontractors, etc.)*

### § 3.2 Guaranteed Maximum Price Proposal

§ 3.2.1 At a time to be mutually agreed upon by the Owner and the Construction Manager, the Construction Manager shall prepare a Guaranteed Maximum Price proposal for the Owner's and Architect's review, and the Owner's acceptance. The Guaranteed Maximum Price in the proposal shall be the sum of the Construction Manager's estimate of the Cost of the Work, the Construction Manager's contingency described in Section 3.2.4, and the Construction Manager's Fee described in Section 6.1.2.

§ 3.2.2 To the extent that the Contract Documents are anticipated to require further development, the Guaranteed Maximum Price includes the costs attributable to such further development consistent with the Contract Documents and reasonably inferable therefrom. Such further development does not include changes in scope, systems, kinds and quality of materials, finishes, or equipment, all of which, if required, shall be incorporated by Change Order.

§ 3.2.3 The Construction Manager shall include with the Guaranteed Maximum Price proposal a written statement of its basis, which shall include the following:

- .1 A list of the Drawings and Specifications, including all Addenda thereto, and the Conditions of the Contract;
- .2 A list of the clarifications and assumptions made by the Construction Manager in the preparation of the Guaranteed Maximum Price proposal, including assumptions under Section 3.2.2;
- .3 A statement of the proposed Guaranteed Maximum Price, including a statement of the estimated Cost of the Work organized by trade categories or systems, including allowances; the Construction Manager's contingency set forth in Section 3.2.4; and the Construction Manager's Fee;
- .4 The anticipated date of Substantial Completion upon which the proposed Guaranteed Maximum Price is based; and
- .5 A date by which the Owner must accept the Guaranteed Maximum Price.

§ 3.2.4 In preparing the Construction Manager's Guaranteed Maximum Price proposal, the Construction Manager shall include a contingency for the Construction Manager's exclusive use to cover those costs that are included in the Guaranteed Maximum Price but not otherwise allocated to another line item or included in a Change Order.

§ 3.2.5 The Construction Manager shall meet with the Owner and Architect to review the Guaranteed Maximum Price proposal. In the event that the Owner or Architect discover any inconsistencies or inaccuracies in the information presented, they shall promptly notify the Construction Manager, who shall make appropriate adjustments to the Guaranteed Maximum Price proposal, its basis, or both.

§ 3.2.6 If the Owner notifies the Construction Manager that the Owner has accepted the Guaranteed Maximum Price proposal in writing before the date specified in the Guaranteed Maximum Price proposal, the Guaranteed Maximum Price proposal shall be deemed effective without further acceptance from the Construction Manager. Following acceptance of a Guaranteed Maximum Price, the Owner and Construction Manager shall execute the Guaranteed Maximum Price Amendment amending this Agreement, a copy of which the Owner shall provide to the Architect. The Guaranteed Maximum Price Amendment shall set forth the agreed upon Guaranteed Maximum Price with the information and assumptions upon which it is based.

§ 3.2.7 The Construction Manager shall not incur any cost to be reimbursed as part of the Cost of the Work prior to the execution of the Guaranteed Maximum Price Amendment, unless the Owner provides prior written authorization for such costs.

§ 3.2.8 The Owner shall authorize preparation of revisions to the Contract Documents that incorporate the agreed-upon assumptions and clarifications contained in the Guaranteed Maximum Price Amendment. The Owner shall promptly furnish such revised Contract Documents to the Construction Manager. The Construction Manager shall notify the Owner

and Architect of any inconsistencies between the agreed-upon assumptions and clarifications contained in the Guaranteed Maximum Price Amendment and the revised Contract Documents.

§ 3.2.9 The Construction Manager shall include in the Guaranteed Maximum Price all sales, consumer, use and similar taxes for the Work provided by the Construction Manager that are legally enacted, whether or not yet effective, at the time the Guaranteed Maximum Price Amendment is executed.

### § 3.3 Construction Phase

#### § 3.3.1 General

§ 3.3.1.1 For purposes of Section 8.1.2 of A201–2017, the date of commencement of the Work shall mean the date of commencement of the Construction Phase.

§ 3.3.1.2 The Construction Phase shall commence upon the Owner’s execution of the Guaranteed Maximum Price Amendment or, prior to acceptance of the Guaranteed Maximum Price proposal, by written agreement of the parties. The written agreement shall set forth a description of the Work to be performed by the Construction Manager, and any insurance and bond requirements for Work performed prior to execution of the Guaranteed Maximum Price Amendment.

#### § 3.3.2 Administration

§ 3.3.2.1 The Construction Manager shall schedule and conduct meetings to discuss such matters as procedures, progress, coordination, scheduling, and status of the Work. The Construction Manager shall prepare and promptly distribute minutes of the meetings to the Owner and Architect.

§ 3.3.2.2 Upon the execution of the Guaranteed Maximum Price Amendment, the Construction Manager shall prepare and submit to the Owner and Architect a construction schedule for the Work and a submittal schedule in accordance with Section 3.10 of A201–2017.

#### § 3.3.2.3 Monthly Report

The Construction Manager shall record the progress of the Project. On a monthly basis, or otherwise as agreed to by the Owner, the Construction Manager shall submit written progress reports to the Owner and Architect, showing percentages of completion and other information required by the Owner.

#### § 3.3.2.4 Daily Logs

The Construction Manager shall keep, and make available to the Owner and Architect, a daily log containing a record for each day of weather, portions of the Work in progress, number of workers on site, identification of equipment on site, problems that might affect progress of the work, accidents, injuries, and other information required by the Owner.

#### § 3.3.2.5 Cost Control

The Construction Manager shall develop a system of cost control for the Work, including regular monitoring of actual costs for activities in progress and estimates for uncompleted tasks and proposed changes. The Construction Manager shall identify variances between actual and estimated costs and report the variances to the Owner and Architect, and shall provide this information in its monthly reports to the Owner and Architect, in accordance with Section 3.3.2.3 above.

## ARTICLE 4 OWNER’S RESPONSIBILITIES

### § 4.1 Information and Services Required of the Owner

§ 4.1.1 The Owner shall provide information with reasonable promptness, regarding requirements for and limitations on the Project, including a written program which shall set forth the Owner’s objectives, constraints, and criteria, including schedule, space requirements and relationships, flexibility and expandability, special equipment, systems, sustainability and site requirements.

§ 4.1.2 Prior to the execution of the Guaranteed Maximum Price Amendment, the Construction Manager may request in writing that the Owner provide reasonable evidence that the Owner has made financial arrangements to fulfill the Owner’s obligations under the Contract. After execution of the Guaranteed Maximum Price Amendment, the Construction Manager may request such information as set forth in A201-2017 Section 2.2.

§ 4.1.3 The Owner shall establish and periodically update the Owner’s budget for the Project, including (1) the budget for the Cost of the Work as defined in Article 7, (2) the Owner’s other costs, and (3) reasonable contingencies related to all of these costs. If the Owner significantly increases or decreases the Owner’s budget for the Cost of the Work, the Owner

shall notify the Construction Manager and Architect. The Owner and the Architect, in consultation with the Construction Manager, shall thereafter agree to a corresponding change in the Project's scope and quality.

**§ 4.1.4 Structural and Environmental Tests, Surveys and Reports.** During the Preconstruction Phase, the Owner shall furnish the following information or services with reasonable promptness. The Owner shall also furnish any other information or services under the Owner's control and relevant to the Construction Manager's performance of the Work with reasonable promptness after receiving the Construction Manager's written request for such information or services. The Construction Manager shall be entitled to rely on the accuracy of information and services furnished by the Owner but shall exercise proper precautions relating to the safe performance of the Work.

**§ 4.1.4.1** The Owner shall furnish tests, inspections, and reports, required by law and as otherwise agreed to by the parties, such as structural, mechanical, and chemical tests, tests for air and water pollution, and tests for hazardous materials.

**§ 4.1.4.2** The Owner shall furnish surveys describing physical characteristics, legal limitations and utility locations for the site of the Project, and a written legal description of the site. The surveys and legal information shall include, as applicable, grades and lines of streets, alleys, pavements and adjoining property and structures; designated wetlands; adjacent drainage; rights-of-way, restrictions, easements, encroachments, zoning, deed restrictions, boundaries and contours of the site; locations, dimensions and other necessary data with respect to existing buildings, other improvements and trees; and information concerning available utility services and lines, both public and private, above and below grade, including inverts and depths. All the information on the survey shall be referenced to a Project benchmark.

**§ 4.1.4.3** The Owner, when such services are requested, shall furnish services of geotechnical engineers, which may include test borings, test pits, determinations of soil bearing values, percolation tests, evaluations of hazardous materials, seismic evaluation, ground corrosion tests and resistivity tests, including necessary operations for anticipating subsoil conditions, with written reports and appropriate recommendations.

**§ 4.1.5** During the Construction Phase, the Owner shall furnish information or services required of the Owner by the Contract Documents with reasonable promptness. The Owner shall also furnish any other information or services under the Owner's control and relevant to the Construction Manager's performance of the Work with reasonable promptness after receiving the Construction Manager's written request for such information or services.

**§ 4.1.6** If the Owner identified a Sustainable Objective in Article 1, the Owner shall fulfill its responsibilities as required in AIA Document E234™-2019, Sustainable Projects Exhibit, Construction Manager as Constructor Edition, attached to this Agreement.

#### **§ 4.2 Owner's Designated Representative**

The Owner shall identify a representative authorized to act on behalf of the Owner with respect to the Project. The Owner's representative shall render decisions promptly and furnish information expeditiously, so as to avoid unreasonable delay in the services or Work of the Construction Manager. Except as otherwise provided in Section 4.2.1 of A201-2017, the Architect does not have such authority. The term "Owner" means the Owner or the Owner's authorized representative.

**§ 4.2.1 Legal Requirements.** The Owner shall furnish all legal, insurance and accounting services, including auditing services, that may be reasonably necessary at any time for the Project to meet the Owner's needs and interests.

#### **§ 4.3 Architect**

The Owner shall retain an Architect to provide services, duties and responsibilities as described in AIA Document B133™-2019, Standard Form of Agreement Between Owner and Architect, Construction Manager as Constructor Edition, including any additional services requested by the Construction Manager that are necessary for the Preconstruction and Construction Phase services under this Agreement. The Owner shall provide the Construction Manager with a copy of the scope of services in the executed agreement between the Owner and the Architect, and any further modifications to the Architect's scope of services in the agreement.

### **ARTICLE 5 COMPENSATION AND PAYMENTS FOR PRECONSTRUCTION PHASE SERVICES**

#### **§ 5.1 Compensation**

**§ 5.1.1** For the Construction Manager's Preconstruction Phase services described in Sections 3.1 and 3.2, the Owner shall compensate the Construction Manager as follows:

*(Insert amount of, or basis for, compensation and include a list of reimbursable cost items, as applicable.)*

The Construction Manger's compensation for Preconstruction phase services will be a not to exceed amount of \$50,000 subject to the Fee Summary sheet attached to this contract.

**§ 5.1.2** The hourly billing rates for Preconstruction Phase services of the Construction Manager and the Construction Manager's Consultants and Subcontractors, if any, are set forth below.  
*(If applicable, attach an exhibit of hourly billing rates or insert them below.)*

See attached Fee Summary sheet for hourly billing rates.

Individual or Position	Rate
------------------------	------

**§ 5.1.2.1** Hourly billing rates for Preconstruction Phase services include all costs to be paid or incurred by the Construction Manager, as required by law or collective bargaining agreements, for taxes, insurance, contributions, assessments and benefits and, for personnel not covered by collective bargaining agreements, customary benefits such as sick leave, medical and health benefits, holidays, vacations and pensions, and shall remain unchanged unless the parties execute a Modification.

**§ 5.1.3** If the Preconstruction Phase services covered by this Agreement have not been completed within ( ) months of the date of this Agreement, through no fault of the Construction Manager, the Construction Manager's compensation for Preconstruction Phase services shall be equitably adjusted.

**§ 5.2 Payments**

**§ 5.2.1** Unless otherwise agreed, payments for services shall be made monthly in proportion to services performed.

**§ 5.2.2** Payments are due and payable upon presentation of the Construction Manager's invoice. Amounts unpaid 40 days after the invoice date shall bear interest at the rate entered below, or in the absence thereof at the legal rate prevailing from time to time at the principal place of business of the Construction Manager.  
*(Insert rate of monthly or annual interest agreed upon.)*

1.5% monthly

**ARTICLE 6 COMPENSATION FOR CONSTRUCTION PHASE SERVICES**

**§ 6.1 Contract Sum**

**§ 6.1.1** The Owner shall pay the Construction Manager the Contract Sum in current funds for the Construction Manager's performance of the Contract after execution of the Guaranteed Maximum Price Amendment. The Contract Sum is the Cost of the Work as defined in Article 7 plus the Construction Manager's Fee.

**§ 6.1.2** The Construction Manager's Fee:

*(State a lump sum, percentage of Cost of the Work or other provision for determining the Construction Manager's Fee.)*

The Construction Manager's Fee will be 2% applied to the Cost of the Work.

**§ 6.1.3** The method of adjustment of the Construction Manager's Fee for changes in the Work:

The Construction Manager's fee will be adjusted to 2% of the final Cost of Work amount.

**§ 6.1.4** Limitations, if any, on a Subcontractor's overhead and profit for increases in the cost of its portion of the Work:

**§ 6.1.5** Rental rates for Construction Manager-owned equipment shall not exceed percent ( %) of the standard rental rate paid at the place of the Project.

**§ 6.1.6** Liquidated damages, if any:

Init.

*(Insert terms and conditions for liquidated damages, if any.)*

None

**§ 6.1.7 Other:**

*(Insert provisions for bonus, cost savings or other incentives, if any, that might result in a change to the Contract Sum.)*

All savings at the completion of the project will be returned to the Owner.

**§ 6.2 Guaranteed Maximum Price**

The Construction Manager guarantees that the Contract Sum shall not exceed the Guaranteed Maximum Price set forth in the Guaranteed Maximum Price Amendment, subject to additions and deductions by Change Order as provided in the Contract Documents. Costs which would cause the Guaranteed Maximum Price to be exceeded shall be paid by the Construction Manager without reimbursement by the Owner.

**§ 6.3 Changes in the Work**

**§ 6.3.1** The Owner may, without invalidating the Contract, order changes in the Work within the general scope of the Contract consisting of additions, deletions or other revisions. The Owner shall issue such changes in writing. The Construction Manager may be entitled to an equitable adjustment in the Contract Time as a result of changes in the Work.

**§ 6.3.1.1** The Architect may order minor changes in the Work as provided in Article 7 of AIA Document A201–2017, General Conditions of the Contract for Construction.

**§ 6.3.2** Adjustments to the Guaranteed Maximum Price on account of changes in the Work subsequent to the execution of the Guaranteed Maximum Price Amendment may be determined by any of the methods listed in Article 7 of AIA Document A201–2017, General Conditions of the Contract for Construction.

**§ 6.3.3** Adjustments to subcontracts awarded on the basis of a stipulated sum shall be determined in accordance with Article 7 of A201–2017, as they refer to "cost" and "fee," and not by Articles 6 and 7 of this Agreement. Adjustments to subcontracts awarded with the Owner's prior written consent on the basis of cost plus a fee shall be calculated in accordance with the terms of those subcontracts.

**§ 6.3.4** In calculating adjustments to the Guaranteed Maximum Price, the terms "cost" and "costs" as used in Article 7 of AIA Document A201–2017 shall mean the Cost of the Work as defined in Article 7 of this Agreement and the term "fee" shall mean the Construction Manager's Fee as defined in Section 6.1.2 of this Agreement.

**§ 6.3.5** If no specific provision is made in Section 6.1.3 for adjustment of the Construction Manager's Fee in the case of changes in the Work, or if the extent of such changes is such, in the aggregate, that application of the adjustment provisions of Section 6.1.3 will cause substantial inequity to the Owner or Construction Manager, the Construction Manager's Fee shall be equitably adjusted on the same basis that was used to establish the Fee for the original Work, and the Guaranteed Maximum Price shall be adjusted accordingly.

**ARTICLE 7 COST OF THE WORK FOR CONSTRUCTION PHASE**

**§ 7.1 Costs to Be Reimbursed**

**§ 7.1.1** The term Cost of the Work shall mean costs necessarily incurred by the Construction Manager in the proper performance of the Work. The Cost of the Work shall include only the items set forth in Sections 7.1 through 7.7.

**§ 7.1.2** Where, pursuant to the Contract Documents, any cost is subject to the Owner's prior approval, the Construction Manager shall obtain such approval in writing prior to incurring the cost.

**§ 7.1.3** Costs shall be at rates not higher than the standard rates paid at the place of the Project, except with prior approval of the Owner.

**§ 7.2 Labor Costs**

**§ 7.2.1** Wages or salaries of construction workers directly employed by the Construction Manager to perform the construction of the Work at the site or, with the Owner's prior approval, at off-site workshops.

§ 7.2.2 Wages or salaries of the Construction Manager’s supervisory and administrative personnel when stationed at the site and performing Work, with the Owner’s prior approval.

§ 7.2.2.1 Wages or salaries of the Construction Manager’s supervisory and administrative personnel when performing Work and stationed at a location other than the site, but only for that portion of time required for the Work, and limited to the personnel and activities listed below:

*(Identify the personnel, type of activity and, if applicable, any agreed upon percentage of time to be devoted to the Work.)*

See attached Fee Summary Sheet.

§ 7.2.3 Wages and salaries of the Construction Manager’s supervisory or administrative personnel engaged at factories, workshops or while traveling, in expediting the production or transportation of materials or equipment required for the Work, but only for that portion of their time required for the Work.

§ 7.2.4 Costs paid or incurred by the Construction Manager, as required by law or collective bargaining agreements, for taxes, insurance, contributions, assessments and benefits and, for personnel not covered by collective bargaining agreements, customary benefits such as sick leave, medical and health benefits, holidays, vacations and pensions, provided such costs are based on wages and salaries included in the Cost of the Work under Sections 7.2.1 through 7.2.3.

§ 7.2.5 If agreed rates for labor costs, in lieu of actual costs, are provided in this Agreement, the rates shall remain unchanged throughout the duration of this Agreement, unless the parties execute a Modification.

### § 7.3 Subcontract Costs

Payments made by the Construction Manager to Subcontractors in accordance with the requirements of the subcontracts and this Agreement.

### § 7.4 Costs of Materials and Equipment Incorporated in the Completed Construction

§ 7.4.1 Costs, including transportation and storage at the site, of materials and equipment incorporated, or to be incorporated, in the completed construction.

§ 7.4.2 Costs of materials described in the preceding Section 7.4.1 in excess of those actually installed to allow for reasonable waste and spoilage. Unused excess materials, if any, shall become the Owner’s property at the completion of the Work or, at the Owner’s option, shall be sold by the Construction Manager. Any amounts realized from such sales shall be credited to the Owner as a deduction from the Cost of the Work.

### § 7.5 Costs of Other Materials and Equipment, Temporary Facilities and Related Items

§ 7.5.1 Costs of transportation, storage, installation, dismantling, maintenance, and removal of materials, supplies, temporary facilities, machinery, equipment and hand tools not customarily owned by construction workers that are provided by the Construction Manager at the site and fully consumed in the performance of the Work. Costs of materials, supplies, temporary facilities, machinery, equipment, and tools, that are not fully consumed, shall be based on the cost or value of the item at the time it is first used on the Project site less the value of the item when it is no longer used at the Project site. Costs for items not fully consumed by the Construction Manager shall mean fair market value.

§ 7.5.2 Rental charges for temporary facilities, machinery, equipment, and hand tools not customarily owned by construction workers that are provided by the Construction Manager at the site, and the costs of transportation, installation, dismantling, minor repairs, and removal of such temporary facilities, machinery, equipment, and hand tools. Rates and quantities of equipment owned by the Construction Manager, or a related party as defined in Section 7.8, shall be subject to the Owner’s prior approval. The total rental cost of any such equipment may not exceed the purchase price of any comparable item.

§ 7.5.3 Costs of removal of debris from the site of the Work and its proper and legal disposal.

§ 7.5.4 Costs of the Construction Manager’s site office, including general office equipment and supplies.

§ 7.5.5 Costs of materials and equipment suitably stored off the site at a mutually acceptable location, subject to the Owner’s prior approval.

## **§ 7.6 Miscellaneous Costs**

**§ 7.6.1** Premiums for that portion of insurance and bonds required by the Contract Documents that can be directly attributed to this Contract.

**§ 7.6.1.1** Costs for self-insurance, for either full or partial amounts of the coverages required by the Contract Documents, with the Owner's prior approval.

**§ 7.6.1.2** Costs for insurance through a captive insurer owned or controlled by the Construction Manager, with the Owner's prior approval.

**§ 7.6.2** Sales, use, or similar taxes, imposed by a governmental authority, that are related to the Work and for which the Construction Manager is liable.

**§ 7.6.3** Fees and assessments for the building permit, and for other permits, licenses, and inspections, for which the Construction Manager is required by the Contract Documents to pay.

**§ 7.6.4** Fees of laboratories for tests required by the Contract Documents; except those related to defective or nonconforming Work for which reimbursement is excluded under Article 13 of AIA Document A201–2017 or by other provisions of the Contract Documents, and which do not fall within the scope of Section 7.7.3.

**§ 7.6.5** Royalties and license fees paid for the use of a particular design, process, or product, required by the Contract Documents.

**§ 7.6.5.1** The cost of defending suits or claims for infringement of patent rights arising from requirements of the Contract Documents, payments made in accordance with legal judgments against the Construction Manager resulting from such suits or claims, and payments of settlements made with the Owner's consent, unless the Construction Manager had reason to believe that the required design, process, or product was an infringement of a copyright or a patent, and the Construction Manager failed to promptly furnish such information to the Architect as required by Article 3 of AIA Document A201–2017. The costs of legal defenses, judgments, and settlements shall not be included in the Cost of the Work used to calculate the Construction Manager's Fee or subject to the Guaranteed Maximum Price.

**§ 7.6.6** Costs for communications services, electronic equipment, and software, directly related to the Work and located at the site, with the Owner's prior approval.

**§ 7.6.7** Costs of document reproductions and delivery charges.

**§ 7.6.8** Deposits lost for causes other than the Construction Manager's negligence or failure to fulfill a specific responsibility in the Contract Documents.

**§ 7.6.9** Legal, mediation and arbitration costs, including attorneys' fees, other than those arising from disputes between the Owner and Construction Manager, reasonably incurred by the Construction Manager after the execution of this Agreement in the performance of the Work and with the Owner's prior approval, which shall not be unreasonably withheld.

**§ 7.6.10** Expenses incurred in accordance with the Construction Manager's standard written personnel policy for relocation and temporary living allowances of the Construction Manager's personnel required for the Work, with the Owner's prior approval.

**§ 7.6.11** That portion of the reasonable expenses of the Construction Manager's supervisory or administrative personnel incurred while traveling in discharge of duties connected with the Work.

## **§ 7.7 Other Costs and Emergencies**

**§ 7.7.1** Other costs incurred in the performance of the Work, with the Owner's prior approval.

**§ 7.7.2** Costs incurred in taking action to prevent threatened damage, injury, or loss, in case of an emergency affecting the safety of persons and property, as provided in Article 10 of AIA Document A201–2017.

§ 7.7.3 Costs of repairing or correcting damaged or nonconforming Work executed by the Construction Manager, Subcontractors, or suppliers, provided that such damaged or nonconforming Work was not caused by the negligence of, or failure to fulfill a specific responsibility by, the Construction Manager, and only to the extent that the cost of repair or correction is not recovered by the Construction Manager from insurance, sureties, Subcontractors, suppliers, or others.

§ 7.7.4 The costs described in Sections 7.1 through 7.7 shall be included in the Cost of the Work, notwithstanding any provision of AIA Document A201–2017 or other Conditions of the Contract which may require the Construction Manager to pay such costs, unless such costs are excluded by the provisions of Section 7.9.

#### § 7.8 Related Party Transactions

§ 7.8.1 For purposes of this Section 7.8, the term "related party" shall mean (1) a parent, subsidiary, affiliate, or other entity having common ownership of, or sharing common management with, the Construction Manager; (2) any entity in which any stockholder in, or management employee of, the Construction Manager holds an equity interest in excess of ten percent in the aggregate; (3) any entity which has the right to control the business or affairs of the Construction Manager; or (4) any person, or any member of the immediate family of any person, who has the right to control the business or affairs of the Construction Manager.

§ 7.8.2 If any of the costs to be reimbursed arise from a transaction between the Construction Manager and a related party, the Construction Manager shall notify the Owner of the specific nature of the contemplated transaction, including the identity of the related party and the anticipated cost to be incurred, before any such transaction is consummated or cost incurred. If the Owner, after such notification, authorizes the proposed transaction in writing, then the cost incurred shall be included as a cost to be reimbursed, and the Construction Manager shall procure the Work, equipment, goods, or service, from the related party, as a Subcontractor, according to the terms of Article 9. If the Owner fails to authorize the transaction in writing, the Construction Manager shall procure the Work, equipment, goods, or service from some person or entity other than a related party according to the terms of Article 9.

#### § 7.9 Costs Not To Be Reimbursed

§ 7.9.1 The Cost of the Work shall not include the items listed below:

- .1 Salaries and other compensation of the Construction Manager's personnel stationed at the Construction Manager's principal office or offices other than the site office, except as specifically provided in Section 7.2, or as may be provided in Article 14;
- .2 Bonuses, profit sharing, incentive compensation, and any other discretionary payments, paid to anyone hired by the Construction Manager or paid to any Subcontractor or vendor, unless the Owner has provided prior approval;
- .3 Expenses of the Construction Manager's principal office and offices other than the site office;
- .4 Overhead and general expenses, except as may be expressly included in Sections 7.1 to 7.7;
- .5 The Construction Manager's capital expenses, including interest on the Construction Manager's capital employed for the Work;
- .6 Except as provided in Section 7.7.3 of this Agreement, costs due to the negligence of, or failure to fulfill a specific responsibility of the Contract by, the Construction Manager, Subcontractors, and suppliers, or anyone directly or indirectly employed by any of them or for whose acts any of them may be liable;
- .7 Any cost not specifically and expressly described in Sections 7.1 to 7.7;
- .8 Costs, other than costs included in Change Orders approved by the Owner, that would cause the Guaranteed Maximum Price to be exceeded; and
- .9 Costs for services incurred during the Preconstruction Phase.

#### ARTICLE 8 DISCOUNTS, REBATES, AND REFUNDS

§ 8.1 Cash discounts obtained on payments made by the Construction Manager shall accrue to the Owner if (1) before making the payment, the Construction Manager included the amount to be paid, less such discount, in an Application for Payment and received payment from the Owner, or (2) the Owner has deposited funds with the Construction Manager with which to make payments; otherwise, cash discounts shall accrue to the Construction Manager. Trade discounts, rebates, refunds, and amounts received from sales of surplus materials and equipment shall accrue to the Owner, and the Construction Manager shall make provisions so that they can be obtained.

§ 8.2 Amounts that accrue to the Owner in accordance with the provisions of Section 8.1 shall be credited to the Owner as a deduction from the Cost of the Work.

## **ARTICLE 9 SUBCONTRACTS AND OTHER AGREEMENTS**

**§ 9.1** Those portions of the Work that the Construction Manager does not customarily perform with the Construction Manager's own personnel shall be performed under subcontracts or other appropriate agreements with the Construction Manager. The Owner may designate specific persons from whom, or entities from which, the Construction Manager shall obtain bids. The Construction Manager shall obtain bids from Subcontractors, and from suppliers of materials or equipment fabricated especially for the Work, who are qualified to perform that portion of the Work in accordance with the requirements of the Contract Documents. The Construction Manager shall deliver such bids to the Architect and Owner with an indication as to which bids the Construction Manager intends to accept. The Owner then has the right to review the Construction Manager's list of proposed subcontractors and suppliers in consultation with the Architect and, subject to Section 9.1.1, to object to any subcontractor or supplier. Any advice of the Architect, or approval or objection by the Owner, shall not relieve the Construction Manager of its responsibility to perform the Work in accordance with the Contract Documents. The Construction Manager shall not be required to contract with anyone to whom the Construction Manager has reasonable objection.

**§ 9.1.1** When a specific subcontractor or supplier (1) is recommended to the Owner by the Construction Manager; (2) is qualified to perform that portion of the Work; and (3) has submitted a bid that conforms to the requirements of the Contract Documents without reservations or exceptions, but the Owner requires that another bid be accepted, then the Construction Manager may require that a Change Order be issued to adjust the Guaranteed Maximum Price by the difference between the bid of the person or entity recommended to the Owner by the Construction Manager and the amount of the subcontract or other agreement actually signed with the person or entity designated by the Owner.

**§ 9.2** Subcontracts or other agreements shall conform to the applicable payment provisions of this Agreement, and shall not be awarded on the basis of cost plus a fee without the Owner's prior written approval. If a subcontract is awarded on the basis of cost plus a fee, the Construction Manager shall provide in the subcontract for the Owner to receive the same audit rights with regard to the Subcontractor as the Owner receives with regard to the Construction Manager in Article 10.

## **ARTICLE 10 ACCOUNTING RECORDS**

The Construction Manager shall keep full and detailed records and accounts related to the Cost of the Work, and exercise such controls, as may be necessary for proper financial management under this Contract and to substantiate all costs incurred. The accounting and control systems shall be satisfactory to the Owner. The Owner and the Owner's auditors shall, during regular business hours and upon reasonable notice, be afforded access to, and shall be permitted to audit and copy, the Construction Manager's records and accounts, including complete documentation supporting accounting entries, books, job cost reports, correspondence, instructions, drawings, receipts, subcontracts, Subcontractor's proposals, Subcontractor's invoices, purchase orders, vouchers, memoranda, and other data relating to this Contract. The Construction Manager shall preserve these records for a period of three years after final payment, or for such longer period as may be required by law.

## **ARTICLE 11 PAYMENTS FOR CONSTRUCTION PHASE SERVICES**

### **§ 11.1 Progress Payments**

**§ 11.1.1** Based upon Applications for Payment submitted to the Architect by the Construction Manager, and Certificates for Payment issued by the Architect, the Owner shall make progress payments on account of the Contract Sum, to the Construction Manager, as provided below and elsewhere in the Contract Documents.

**§ 11.1.2** The period covered by each Application for Payment shall be one calendar month ending on the last day of the month, or as follows:

**§ 11.1.3** Provided that an Application for Payment is received by the Architect not later than the 5th day of a month, the Owner shall make payment of the amount certified to the Construction Manager not later than the 15th day of the following month. If an Application for Payment is received by the Architect after the application date fixed above, payment of the amount certified shall be made by the Owner not later than 40 days after the Architect receives the Application for Payment.

*(Federal, state or local laws may require payment within a certain period of time.)*

**§ 11.1.4** With each Application for Payment, the Construction Manager shall submit payrolls, petty cash accounts, receipted invoices or invoices with check vouchers attached, and any other evidence required by the Owner or Architect to demonstrate

that payments already made by the Construction Manager on account of the Cost of the Work equal or exceed progress payments already received by the Construction Manager, plus payrolls for the period covered by the present Application for Payment, less that portion of the progress payments attributable to the Construction Manager's Fee.

§ 11.1.5 Each Application for Payment shall be based on the most recent schedule of values submitted by the Construction Manager in accordance with the Contract Documents. The schedule of values shall allocate the entire Guaranteed Maximum Price among: (1) the various portions of the Work; (2) any contingency for costs that are included in the Guaranteed Maximum Price but not otherwise allocated to another line item or included in a Change Order; and (3) the Construction Manager's Fee.

§ 11.1.5.1 The schedule of values shall be prepared in such form and supported by such data to substantiate its accuracy as the Architect may require. The schedule of values shall be used as a basis for reviewing the Construction Manager's Applications for Payment.

§ 11.1.5.2 The allocation of the Guaranteed Maximum Price under this Section 11.1.5 shall not constitute a separate guaranteed maximum price for the Cost of the Work of each individual line item in the schedule of values.

§ 11.1.5.3 When the Construction Manager allocates costs from a contingency to another line item in the schedule of values, the Construction Manager shall submit supporting documentation to the Architect.

§ 11.1.6 Applications for Payment shall show the percentage of completion of each portion of the Work as of the end of the period covered by the Application for Payment. The percentage of completion shall be the lesser of (1) the percentage of that portion of the Work which has actually been completed, or (2) the percentage obtained by dividing (a) the expense that has actually been incurred by the Construction Manager on account of that portion of the Work and for which the Construction Manager has made payment or intends to make payment prior to the next Application for Payment, by (b) the share of the Guaranteed Maximum Price allocated to that portion of the Work in the schedule of values.

§ 11.1.7 In accordance with AIA Document A201–2017 and subject to other provisions of the Contract Documents, the amount of each progress payment shall be computed as follows:

§ 11.1.7.1 The amount of each progress payment shall first include:

- .1 That portion of the Guaranteed Maximum Price properly allocable to completed Work as determined by multiplying the percentage of completion of each portion of the Work by the share of the Guaranteed Maximum Price allocated to that portion of the Work in the most recent schedule of values;
- .2 That portion of the Guaranteed Maximum Price properly allocable to materials and equipment delivered and suitably stored at the site for subsequent incorporation in the completed construction or, if approved in writing in advance by the Owner, suitably stored off the site at a location agreed upon in writing;
- .3 That portion of Construction Change Directives that the Architect determines, in the Architect's professional judgment, to be reasonably justified; and
- .4 The Construction Manager's Fee, computed upon the Cost of the Work described in the preceding Sections 11.1.7.1.1 and 11.1.7.1.2 at the rate stated in Section 6.1.2 or, if the Construction Manager's Fee is stated as a fixed sum in that Section, an amount that bears the same ratio to that fixed-sum fee as the Cost of the Work included in Sections 11.1.7.1.1 and 11.1.7.1.2 bears to a reasonable estimate of the probable Cost of the Work upon its completion.

§ 11.1.7.2 The amount of each progress payment shall then be reduced by:

- .1 The aggregate of any amounts previously paid by the Owner;
- .2 The amount, if any, for Work that remains uncorrected and for which the Architect has previously withheld a Certificate for Payment as provided in Article 9 of AIA Document A201–2017;
- .3 Any amount for which the Construction Manager does not intend to pay a Subcontractor or material supplier, unless the Work has been performed by others the Construction Manager intends to pay;
- .4 For Work performed or defects discovered since the last payment application, any amount for which the Architect may withhold payment, or nullify a Certificate of Payment in whole or in part, as provided in Article 9 of AIA Document A201–2017;
- .5 The shortfall, if any, indicated by the Construction Manager in the documentation required by Section 11.1.4 to substantiate prior Applications for Payment, or resulting from errors subsequently discovered by the Owner's auditors in such documentation; and

**.6 Retainage withheld pursuant to Section 11.1.8.**

**§ 11.1.8 Retainage**

**§ 11.1.8.1** For each progress payment made prior to Substantial Completion of the Work, the Owner may withhold the following amount, as retainage, from the payment otherwise due:

*(Insert a percentage or amount to be withheld as retainage from each Application for Payment. The amount of retainage may be limited by governing law.)*

5% on all work

**§ 11.1.8.1.1** The following items are not subject to retainage:

*(Insert any items not subject to the withholding of retainage, such as general conditions, insurance, etc.)*

Reductions in retainage are subject to the MN Prompt Payment Act

**§ 11.1.8.2** Reduction or limitation of retainage, if any, shall be as follows:

*(If the retainage established in Section 11.1.8.1 is to be modified prior to Substantial Completion of the entire Work, insert provisions for such modification.)*

Reductions in retainage are subject to the MN Prompt Payment Act

**§ 11.1.8.3** Except as set forth in this Section 11.1.8.3, upon Substantial Completion of the Work, the Construction Manager may submit an Application for Payment that includes the retainage withheld from prior Applications for Payment pursuant to this Section 11.1.8. The Application for Payment submitted at Substantial Completion shall not include retainage as follows:

*(Insert any other conditions for release of retainage, such as upon completion of the Owner's audit and reconciliation, upon Substantial Completion.)*

**§ 11.1.9** If final completion of the Work is materially delayed through no fault of the Construction Manager, the Owner shall pay the Construction Manager any additional amounts in accordance with Article 9 of AIA Document A201–2017.

**§ 11.1.10** Except with the Owner's prior written approval, the Construction Manager shall not make advance payments to suppliers for materials or equipment which have not been delivered and suitably stored at the site.

**§ 11.1.11** The Owner and the Construction Manager shall agree upon a mutually acceptable procedure for review and approval of payments to Subcontractors, and the percentage of retainage held on Subcontracts, and the Construction Manager shall execute subcontracts in accordance with those agreements.

**§ 11.1.12** In taking action on the Construction Manager's Applications for Payment the Architect shall be entitled to rely on the accuracy and completeness of the information furnished by the Construction Manager, and such action shall not be deemed to be a representation that (1) the Architect has made a detailed examination, audit, or arithmetic verification, of the documentation submitted in accordance with Section 11.1.4 or other supporting data; (2) that the Architect has made exhaustive or continuous on-site inspections; or (3) that the Architect has made examinations to ascertain how or for what purposes the Construction Manager has used amounts previously paid on account of the Contract. Such examinations, audits, and verifications, if required by the Owner, will be performed by the Owner's auditors acting in the sole interest of the Owner.

**§ 11.2 Final Payment**

**§ 11.2.1** Final payment, constituting the entire unpaid balance of the Contract Sum, shall be made by the Owner to the Construction Manager when

- .1** the Construction Manager has fully performed the Contract, except for the Construction Manager's responsibility to correct Work as provided in Article 12 of AIA Document A201–2017, and to satisfy other requirements, if any, which extend beyond final payment;
- .2** the Construction Manager has submitted a final accounting for the Cost of the Work and a final Application for Payment; and

.3 a final Certificate for Payment has been issued by the Architect in accordance with Section 11.2.2.2.

§ 11.2.2 Within 30 days of the Owner's receipt of the Construction Manager's final accounting for the Cost of the Work, the Owner shall conduct an audit of the Cost of the Work or notify the Architect that it will not conduct an audit.

§ 11.2.2.1 If the Owner conducts an audit of the Cost of the Work, the Owner shall, within 10 days after completion of the audit, submit a written report based upon the auditors' findings to the Architect.

§ 11.2.2.2 Within seven days after receipt of the written report described in Section 11.2.2.1, or receipt of notice that the Owner will not conduct an audit, and provided that the other conditions of Section 11.2.1 have been met, the Architect will either issue to the Owner a final Certificate for Payment with a copy to the Construction Manager, or notify the Construction Manager and Owner in writing of the Architect's reasons for withholding a certificate as provided in Article 9 of AIA Document A201–2017. The time periods stated in this Section 11.2.2 supersede those stated in Article 9 of AIA Document A201–2017. The Architect is not responsible for verifying the accuracy of the Construction Manager's final accounting.

§ 11.2.2.3 If the Owner's auditors' report concludes that the Cost of the Work, as substantiated by the Construction Manager's final accounting, is less than claimed by the Construction Manager, the Construction Manager shall be entitled to request mediation of the disputed amount without seeking an initial decision pursuant to Article 15 of AIA Document A201–2017. A request for mediation shall be made by the Construction Manager within 30 days after the Construction Manager's receipt of a copy of the Architect's final Certificate for Payment. Failure to request mediation within this 30-day period shall result in the substantiated amount reported by the Owner's auditors becoming binding on the Construction Manager. Pending a final resolution of the disputed amount, the Owner shall pay the Construction Manager the amount certified in the Architect's final Certificate for Payment.

§ 11.2.3 The Owner's final payment to the Construction Manager shall be made no later than 30 days after the issuance of the Architect's final Certificate for Payment, or as follows:

§ 11.2.4 If, subsequent to final payment, and at the Owner's request, the Construction Manager incurs costs, described in Sections 7.1 through 7.7, and not excluded by Section 7.9, to correct defective or nonconforming Work, the Owner shall reimburse the Construction Manager for such costs, and the Construction Manager's Fee applicable thereto, on the same basis as if such costs had been incurred prior to final payment, but not in excess of the Guaranteed Maximum Price. If adjustments to the Contract Sum are provided for in Section 6.1.7, the amount of those adjustments shall be recalculated, taking into account any reimbursements made pursuant to this Section 11.2.4 in determining the net amount to be paid by the Owner to the Construction Manager.

### § 11.3 Interest

Payments due and unpaid under the Contract shall bear interest from the date payment is due at the rate stated below, or in the absence thereof, at the legal rate prevailing from time to time at the place where the Project is located.

*(Insert rate of interest agreed upon, if any.)*

1.5% monthly

## ARTICLE 12 DISPUTE RESOLUTION

### § 12.1 Initial Decision Maker

§ 12.1.1 Any Claim between the Owner and Construction Manager shall be resolved in accordance with the provisions set forth in this Article 12 and Article 15 of A201–2017. However, for Claims arising from or relating to the Construction Manager's Preconstruction Phase services, no decision by the Initial Decision Maker shall be required as a condition precedent to mediation or binding dispute resolution, and Section 12.1.2 of this Agreement shall not apply.

§ 12.1.2 The Architect will serve as the Initial Decision Maker pursuant to Article 15 of AIA Document A201–2017 for Claims arising from or relating to the Construction Manager's Construction Phase services, unless the parties appoint below another individual, not a party to the Agreement, to serve as the Initial Decision Maker.

*(If the parties mutually agree, insert the name, address and other contact information of the Initial Decision Maker, if other than the Architect.)*

## § 12.2 Binding Dispute Resolution

For any Claim subject to, but not resolved by mediation pursuant to Article 15 of AIA Document A201–2017, the method of binding dispute resolution shall be as follows:

*(Check the appropriate box.)*

- [ X ] Arbitration pursuant to Article 15 of AIA Document A201–2017
- [ ] Litigation in a court of competent jurisdiction
- [ ] Other: *(Specify)*

If the Owner and Construction Manager do not select a method of binding dispute resolution, or do not subsequently agree in writing to a binding dispute resolution method other than litigation, Claims will be resolved by litigation in a court of competent jurisdiction.

## ARTICLE 13 TERMINATION OR SUSPENSION

### § 13.1 Termination Prior to Execution of the Guaranteed Maximum Price Amendment

§ 13.1.1 If the Owner and the Construction Manager do not reach an agreement on the Guaranteed Maximum Price, the Owner may terminate this Agreement upon not less than seven days' written notice to the Construction Manager, and the Construction Manager may terminate this Agreement, upon not less than seven days' written notice to the Owner.

§ 13.1.2 In the event of termination of this Agreement pursuant to Section 13.1.1, the Construction Manager shall be compensated for Preconstruction Phase services and Work performed prior to receipt of a notice of termination, in accordance with the terms of this Agreement. In no event shall the Construction Manager's compensation under this Section exceed the compensation set forth in Section 5.1.

§ 13.1.3 Prior to the execution of the Guaranteed Maximum Price Amendment, the Owner may terminate this Agreement upon not less than seven days' written notice to the Construction Manager for the Owner's convenience and without cause, and the Construction Manager may terminate this Agreement, upon not less than seven days' written notice to the Owner, for the reasons set forth in Article 14 of A201–2017.

§ 13.1.4 In the event of termination of this Agreement pursuant to Section 13.1.3, the Construction Manager shall be equitably compensated for Preconstruction Phase services and Work performed prior to receipt of a notice of termination. In no event shall the Construction Manager's compensation under this Section exceed the compensation set forth in Section 5.1.

§ 13.1.5 If the Owner terminates the Contract pursuant to Section 13.1.3 after the commencement of the Construction Phase but prior to the execution of the Guaranteed Maximum Price Amendment, the Owner shall pay to the Construction Manager an amount calculated as follows, which amount shall be in addition to any compensation paid to the Construction Manager under Section 13.1.4:

- .1 Take the Cost of the Work incurred by the Construction Manager to the date of termination;
- .2 Add the Construction Manager's Fee computed upon the Cost of the Work to the date of termination at the rate stated in Section 6.1 or, if the Construction Manager's Fee is stated as a fixed sum in that Section, an amount that bears the same ratio to that fixed-sum Fee as the Cost of the Work at the time of termination bears to a reasonable estimate of the probable Cost of the Work upon its completion; and
- .3 Subtract the aggregate of previous payments made by the Owner for Construction Phase services.

§ 13.1.6 The Owner shall also pay the Construction Manager fair compensation, either by purchase or rental at the election of the Owner, for any equipment owned by the Construction Manager that the Owner elects to retain and that is not

otherwise included in the Cost of the Work under Section 13.1.5.1. To the extent that the Owner elects to take legal assignment of subcontracts and purchase orders (including rental agreements), the Construction Manager shall, as a condition of receiving the payments referred to in this Article 13, execute and deliver all such papers and take all such steps, including the legal assignment of such subcontracts and other contractual rights of the Construction Manager, as the Owner may require for the purpose of fully vesting in the Owner the rights and benefits of the Construction Manager under such subcontracts or purchase orders. All Subcontracts, purchase orders and rental agreements entered into by the Construction Manager will contain provisions allowing for assignment to the Owner as described above.

**§ 13.1.6.1** If the Owner accepts assignment of subcontracts, purchase orders or rental agreements as described above, the Owner will reimburse or indemnify the Construction Manager for all costs arising under the subcontract, purchase order or rental agreement, if those costs would have been reimbursable as Cost of the Work if the contract had not been terminated. If the Owner chooses not to accept assignment of any subcontract, purchase order or rental agreement that would have constituted a Cost of the Work had this agreement not been terminated, the Construction Manager will terminate the subcontract, purchase order or rental agreement and the Owner will pay the Construction Manager the costs necessarily incurred by the Construction Manager because of such termination.

### **§ 13.2 Termination or Suspension Following Execution of the Guaranteed Maximum Price Amendment**

#### **§ 13.2.1 Termination**

The Contract may be terminated by the Owner or the Construction Manager as provided in Article 14 of AIA Document A201–2017.

#### **§ 13.2.2 Termination by the Owner for Cause**

**§ 13.2.2.1** If the Owner terminates the Contract for cause as provided in Article 14 of AIA Document A201–2017, the amount, if any, to be paid to the Construction Manager under Article 14 of AIA Document A201–2017 shall not cause the Guaranteed Maximum Price to be exceeded, nor shall it exceed an amount calculated as follows:

- .1 Take the Cost of the Work incurred by the Construction Manager to the date of termination;
- .2 Add the Construction Manager’s Fee, computed upon the Cost of the Work to the date of termination at the rate stated in Section 6.1 or, if the Construction Manager’s Fee is stated as a fixed sum in that Section, an amount that bears the same ratio to that fixed-sum Fee as the Cost of the Work at the time of termination bears to a reasonable estimate of the probable Cost of the Work upon its completion;
- .3 Subtract the aggregate of previous payments made by the Owner; and
- .4 Subtract the costs and damages incurred, or to be incurred, by the Owner under Article 14 of AIA Document A201–2017.

**§ 13.2.2.2** The Owner shall also pay the Construction Manager fair compensation, either by purchase or rental at the election of the Owner, for any equipment owned by the Construction Manager that the Owner elects to retain and that is not otherwise included in the Cost of the Work under Section 13.2.2.1.1. To the extent that the Owner elects to take legal assignment of subcontracts and purchase orders (including rental agreements), the Construction Manager shall, as a condition of receiving the payments referred to in this Article 13, execute and deliver all such papers and take all such steps, including the legal assignment of such subcontracts and other contractual rights of the Construction Manager, as the Owner may require for the purpose of fully vesting in the Owner the rights and benefits of the Construction Manager under such subcontracts or purchase orders.

#### **§ 13.2.3 Termination by the Owner for Convenience**

If the Owner terminates the Contract for convenience in accordance with Article 14 of AIA Document A201–2017, then the Owner shall pay the Construction Manager a termination fee as follows:

*(Insert the amount of or method for determining the fee, if any, payable to the Construction Manager following a termination for the Owner’s convenience.)*

### **§ 13.3 Suspension**

The Work may be suspended by the Owner as provided in Article 14 of AIA Document A201–2017; in such case, the Guaranteed Maximum Price and Contract Time shall be increased as provided in Article 14 of AIA Document A201–2017, except that the term "profit" shall be understood to mean the Construction Manager’s Fee as described in Sections 6.1 and 6.3.5 of this Agreement.

**ARTICLE 14 MISCELLANEOUS PROVISIONS**

§ 14.1 Terms in this Agreement shall have the same meaning as those in A201–2017. Where reference is made in this Agreement to a provision of AIA Document A201–2017 or another Contract Document, the reference refers to that provision as amended or supplemented by other provisions of the Contract Documents.

**§ 14.2 Successors and Assigns**

§ 14.2.1 The Owner and Construction Manager, respectively, bind themselves, their partners, successors, assigns and legal representatives to covenants, agreements, and obligations contained in the Contract Documents. Except as provided in Section 14.2.2 of this Agreement, and in Section 13.2.2 of A201–2017, neither party to the Contract shall assign the Contract as a whole without written consent of the other. If either party attempts to make an assignment without such consent, that party shall nevertheless remain legally responsible for all obligations under the Contract.

§ 14.2.2 The Owner may, without consent of the Construction Manager, assign the Contract to a lender providing construction financing for the Project, if the lender assumes the Owner’s rights and obligations under the Contract Documents. The Construction Manager shall execute all consents reasonably required to facilitate the assignment.

**§ 14.3 Insurance and Bonds**

**§ 14.3.1 Preconstruction Phase**

The Construction Manager shall maintain the following insurance for the duration of the Preconstruction Services performed under this Agreement. If any of the requirements set forth below exceed the types and limits the Construction Manager normally maintains, the Owner shall reimburse the Construction Manager for any additional cost.

§ 14.3.1.1 Commercial General Liability with policy limits of not less than \$2,000,000 for each occurrence and \$3,000,000 in the aggregate for bodily injury and property damage.

§ 14.3.1.2 Automobile Liability covering vehicles owned, and non-owned vehicles used, by the Construction Manager with policy limits of not less than \$1,000,000 per accident for bodily injury, death of any person, and property damage arising out of the ownership, maintenance and use of those motor vehicles, along with any other statutorily required automobile coverage.

§ 14.3.1.3 The Construction Manager may achieve the required limits and coverage for Commercial General Liability and Automobile Liability through a combination of primary and excess or umbrella liability insurance, provided that such primary and excess or umbrella liability insurance policies result in the same or greater coverage as the coverages required under Sections 14.3.1.1 and 14.3.1.2, and in no event shall any excess or umbrella liability insurance provide narrower coverage than the primary policy. The excess policy shall not require the exhaustion of the underlying limits only through the actual payment by the underlying insurers.

§ 14.3.1.4 Workers’ Compensation at statutory limits and Employers Liability with policy limits not less than \$1,000,000 each accident, \$1,000,000 each employee, and \$1,000,000 policy limit.

§ 14.3.1.5 Professional Liability covering negligent acts, errors and omissions in the performance of professional services, with policy limits of not less than \$2,000,000 per claim and \$2,000,000 in the aggregate.

**§ 14.3.1.6 Other Insurance**

*(List below any other insurance coverage to be provided by the Construction Manager and any applicable limits.)*

**Coverage**

**Limits**

§ 14.3.1.7 **Additional Insured Obligations.** To the fullest extent permitted by law, the Construction Manager shall cause the primary and excess or umbrella policies for Commercial General Liability and Automobile Liability to include the Owner as an additional insured for claims caused in whole or in part by the Construction Manager’s negligent acts or omissions. The additional insured coverage shall be primary and non-contributory to any of the Owner’s insurance policies and shall apply to both ongoing and completed operations.

§ 14.3.1.8 The Construction Manager shall provide certificates of insurance to the Owner that evidence compliance with the requirements in this Section 14.3.1.

Init.

**§ 14.3.2 Construction Phase**

After execution of the Guaranteed Maximum Price Amendment, the Owner and the Construction Manager shall purchase and maintain insurance as set forth in AIA Document A133™–2019, Standard Form of Agreement Between Owner and Construction Manager as Constructor where the basis of payment is the Cost of the Work Plus a Fee with a Guaranteed Maximum Price, Exhibit B, Insurance and Bonds, and elsewhere in the Contract Documents.

**§ 14.3.2.1** The Construction Manager shall provide bonds as set forth in AIA Document A133™–2019 Exhibit B, and elsewhere in the Contract Documents.

**§ 14.4** Notice in electronic format, pursuant to Article 1 of AIA Document A201–2017, may be given in accordance with a building information modeling exhibit, if completed, or as otherwise set forth below:

*(If other than in accordance with a building information modeling exhibit, insert requirements for delivering notice in electronic format such as name, title, and email address of the recipient and whether and how the system will be required to generate a read receipt for the transmission.)*

Notice can be provided via email to the representative identified in this email

**§ 14.5** Other provisions:

**ARTICLE 15 SCOPE OF THE AGREEMENT**

**§ 15.1** This Agreement represents the entire and integrated agreement between the Owner and the Construction Manager and supersedes all prior negotiations, representations or agreements, either written or oral. This Agreement may be amended only by written instrument signed by both Owner and Construction Manager.

**§ 15.2** The following documents comprise the Agreement:

- .1 AIA Document A133™–2019, Standard Form of Agreement Between Owner and Construction Manager as Constructor where the basis of payment is the Cost of the Work Plus a Fee with a Guaranteed Maximum Price
- .2 AIA Document A133™–2019, Exhibit A, Guaranteed Maximum Price Amendment, if executed
- .3 AIA Document A133™–2019, Exhibit B, Insurance and Bonds
- .4 AIA Document A201™–2017, General Conditions of the Contract for Construction
- .5 Building Information Modeling Exhibit, if completed:

.6 Other Exhibits:  
*(Check all boxes that apply.)*

AIA Document E234™–2019, Sustainable Projects Exhibit, Construction Manager as Constructor Edition, dated as indicated below:  
*(Insert the date of the E234-2019 incorporated into this Agreement.)*

Supplementary and other Conditions of the Contract:

Document	Title	Date	Pages
----------	-------	------	-------

.7 Other documents, if any, listed below:  
*(List here any additional documents that are intended to form part of the Contract Documents. AIA Document A201–2017 provides that the advertisement or invitation to bid, Instructions to Bidders, sample forms, the Construction Manager’s bid or proposal, portions of Addenda relating to bidding or proposal requirements, and other information furnished by the Owner in anticipation of receiving bids or proposals,*

are not part of the Contract Documents unless enumerated in this Agreement. Any such documents should be listed here only if intended to be part of the Contract Documents.)

This Agreement is entered into as of the day and year first written above.

\_\_\_\_\_  
**OWNER** *(Signature)*

\_\_\_\_\_  
*(Printed name and title)*

\_\_\_\_\_  
**CONSTRUCTION MANAGER** *(Signature)*

\_\_\_\_\_  
Joseph A. Uhlhorn, Project Executive + Partner  
*(Printed name and title)*



# **Additions and Deletions Report for** **AIA® Document A133® – 2019**

This Additions and Deletions Report, as defined on page 1 of the associated document, reproduces below all text the author has added to the standard form AIA document in order to complete it, as well as any text the author may have added to or deleted from the original AIA text. Added text is shown underlined. Deleted text is indicated with a horizontal line through the original AIA text.

Note: This Additions and Deletions Report is provided for information purposes only and is not incorporated into or constitute any part of the associated AIA document. This Additions and Deletions Report and its associated document were generated simultaneously by AIA software at 10:24:29 ET on 10/16/2025.

## **PAGE 1**

City of Ramsey  
14199 Jasper Street  
Ramsey, MN 55303

...

Hoffmann+Uhlhorn Construction, Inc. dba H+U Construction  
5555 W 78th Street, Suite A  
Minneapolis, MN 55439

...

Waterfront Park  
Ramsey, MN

...

*(Name, legal status, address, and other information)*

Damon Farber Landscape Architects  
310 4th Ave S, Suite 7050  
Minneapolis, MN 55415

## **PAGE 3**

June 30, 2026

...

The project must be complete and open to the public by June 30, 2026

...

Mark Riverblood  
Parks and Assistant Public Works Director  
14199 Jasper Street  
Ramsey, MN 55303  
mriverblood@ci.ramsey.mn.us  
763-238-1733

## **PAGE 4**

Braun Intertec

...

Chuck Evans, PLA  
Associate Principal  
310 S 4th Street, Suite 7050  
Minneapolis, MN 55415  
cevens@damonfarber.com  
651-216-6115

...

Joe Uhlhorn  
Project Executive + Partner  
5555 W 78th Street, Suite A  
Minneapolis, MN 55439  
juhlhorn@hu-construction.com  
651-335-4634

**PAGE 11**

The Construction Manger’s compensation for Preconstruction phase services will be a not to exceed amount of \$50,000 subject to the Fee Summary sheet attached to this contract.

...

See attached Fee Summary sheet for hourly billing rates.

...

**§ 5.2.2** Payments are due and payable upon presentation of the Construction Manager’s invoice. Amounts unpaid (—) 40 days after the invoice date shall bear interest at the rate entered below, or in the absence thereof at the legal rate prevailing from time to time at the principal place of business of the Construction Manager.

...

%—1.5% monthly

...

The Construction Manager’s Fee will be 2% applied to the Cost of the Work.

...

The Construction Manager’s fee will be adjusted to 2% of the final Cost of Work amount.

**PAGE 12**

None

...

All savings at the completion of the project will be returned to the Owner.

**PAGE 13**

See attached Fee Summary Sheet.

**PAGE 16**

**§ 11.1.3** Provided that an Application for Payment is received by the Architect not later than the 5<sup>th</sup> day of a month, the Owner shall make payment of the amount certified to the Construction Manager not later than the 15<sup>th</sup> day of the

following month. If an Application for Payment is received by the Architect after the application date fixed above, payment of the amount certified shall be made by the Owner not later than ~~( ) days~~ 40 days after the Architect receives the Application for Payment.

**PAGE 18**

5% on all work

...

Reductions in retainage are subject to the MN Prompt Payment Act

...

Reductions in retainage are subject to the MN Prompt Payment Act

**PAGE 19**

% ~~1.5%~~ monthly

**PAGE 20**

Arbitration pursuant to Article 15 of AIA Document A201-2017

**PAGE 22**

§ 14.3.1.1 Commercial General Liability with policy limits of not less than ~~( \$ )~~ \$2,000,000 for each occurrence and ~~( \$ )~~ \$3,000,000 in the aggregate for bodily injury and property damage.

§ 14.3.1.2 Automobile Liability covering vehicles owned, and non-owned vehicles used, by the Construction Manager with policy limits of not less than ~~( \$ )~~ \$1,000,000 per accident for bodily injury, death of any person, and property damage arising out of the ownership, maintenance and use of those motor vehicles, along with any other statutorily required automobile coverage.

...

§ 14.3.1.4 Workers' Compensation at statutory limits and Employers Liability with policy limits not less than ~~( \$ )~~ \$1,000,000 each accident, ~~( \$ )~~ \$1,000,000 each employee, and ~~( \$ )~~ \$1,000,000 policy limit.

§ 14.3.1.5 Professional Liability covering negligent acts, errors and omissions in the performance of professional services, with policy limits of not less than ~~( \$ )~~ \$2,000,000 per claim and ~~( \$ )~~ \$2,000,000 in the aggregate.

**PAGE 23**

Notice can be provided via email to the representative identified in this email

**PAGE 24**

---

Joseph A. Uhlhorn, Project Executive + Partner

---

## **Certification of Document's Authenticity**

**AIA® Document D401™ – 2003**

I, \_\_\_\_\_, hereby certify, to the best of my knowledge, information and belief, that I created the attached final document simultaneously with its associated Additions and Deletions Report and this certification at 10:24:29 ET on 10/16/2025 under Order No. 4104243742 from AIA Contract Documents software and that in preparing the attached final document I made no changes to the original text of AIA® Document A133™ – 2019, Standard Form of Agreement Between Owner and Construction Manager as Constructor where the basis of payment is the Cost of the Work Plus a Fee with a Guaranteed Maximum Price, other than those additions and deletions shown in the associated Additions and Deletions Report.

\_\_\_\_\_  
*(Signed)*

\_\_\_\_\_  
*(Title)*

\_\_\_\_\_  
*(Dated)*

**RAMSEY WATERFRONT PARK  
H+U CONSTRUCTION COMPENSATION SUMMARY  
BASED ON \$3.1M COST AND 5 MONTH CONSTRUCTION DURATION**

<b>Preconstruction &amp; Bidding Phase Services (NTE Total)</b>				
<b>Description</b>	<b>Quantity</b>	<b>Unit</b>	<b>Rate</b>	<b>Total</b>
Project Executive	80	HR	\$185	\$14,800
Preconstruction Manager	80	HR	\$160	\$12,800
Cost Estimator	80	HR	\$120	\$9,600
MEP Estimator	8	HR	\$185	\$1,480
Project Manager	40	HR	\$145	\$5,800
Project Administrator	25	HR	\$92	\$2,300
Project Accountant	8	HR	\$92	\$736
Project Superintendent	16	HR	\$145	\$2,320
<b>Total Preconstruction Phase Services Not to Exceed Amount*:</b>				<b>\$49,836</b>

<b>Construction &amp; Closeout Phase Services (NTE Total)</b>				
<b>Description</b>	<b>Quantity</b>	<b>Unit</b>	<b>Rate</b>	<b>Total</b>
Project Executive	117	HR	\$185	\$21,645
Project Manager	560	HR	\$145	\$81,200
Assistant Project Manager	400	HR	\$110	\$44,000
Project Administrator	75	HR	\$92	\$6,900
Project Accountant	40	HR	\$92	\$3,680
General Superintendent	200	HR	\$170	\$34,000
Project Superintendent (Full Time)	865	HR	\$145	\$125,425
Health & Safety Director	40	HR	\$150	\$6,000
Field Office Trailer	5	MO	\$1,250	\$6,250
Field Office Equipment & Technology	5	MO	\$300	\$1,500
Superintendent Truck & Travel	5	MO	\$1,200	\$6,000
In-House Printing	5	MO	\$100	\$500
Office Staff Mileage	5	MO	\$200	\$1,000
<b>Total Construction &amp; Closeout Phase Services Not To Exceed Amount*:</b>				<b>\$338,100</b>

	<b>Estimated</b>		
<b>Construction Manger Fee**</b>	<b>Construction Cost</b>	<b>CM Fee %</b>	<b>Total</b>
Construction Manager Fees	\$3,100,000	2.00%	<b>\$62,000</b>

**Construction Manager Total Compensation: \$449,936**

\*The total costs shown are T&M Not to Exceed Amounts and will be invoiced monthly.

\*\*The construction management fee will be adjusted to 2% of the final construction value at completion



# AIA® Document A133® – 2019 Exhibit A

## Guaranteed Maximum Price Amendment

This Amendment dated the \_\_\_ day of \_\_\_ in the year \_\_\_, is incorporated into the accompanying AIA Document A133™–2019, Standard Form of Agreement Between Owner and Construction Manager as Constructor where the basis of payment is the Cost of the Work Plus a Fee with a Guaranteed Maximum Price dated the \_\_\_ day of \_\_\_ in the year \_\_\_ (the "Agreement")

*(In words, indicate day, month, and year.)*

for the following **PROJECT:**  
*(Name and address or location)*

**THE OWNER:**  
*(Name, legal status, and address)*

**THE CONSTRUCTION MANAGER:**  
*(Name, legal status, and address)*

### TABLE OF ARTICLES

- A.1 GUARANTEED MAXIMUM PRICE
- A.2 DATE OF COMMENCEMENT AND SUBSTANTIAL COMPLETION
- A.3 INFORMATION UPON WHICH AMENDMENT IS BASED
- A.4 CONSTRUCTION MANAGER’S CONSULTANTS, CONTRACTORS, DESIGN PROFESSIONALS, AND SUPPLIERS

### ARTICLE A.1 GUARANTEED MAXIMUM PRICE

#### § A.1.1 Guaranteed Maximum Price

Pursuant to Section 3.2.6 of the Agreement, the Owner and Construction Manager hereby amend the Agreement to establish a Guaranteed Maximum Price. As agreed by the Owner and Construction Manager, the Guaranteed Maximum Price is an amount that the Contract Sum shall not exceed. The Contract Sum consists of the Construction Manager’s Fee plus the Cost of the Work, as that term is defined in Article 6 of the Agreement.

§ A.1.1.1 The Contract Sum is guaranteed by the Construction Manager not to exceed (\$ \_\_\_\_\_), subject to additions and deductions by Change Order as provided in the Contract Documents.

§ A.1.1.2 **Itemized Statement of the Guaranteed Maximum Price.** Provided below is an itemized statement of the Guaranteed Maximum Price organized by trade categories,

### ADDITIONS AND DELETIONS:

The author of this document has added information needed for its completion. The author may also have revised the text of the original AIA standard form. An *Additions and Deletions Report* that notes added information as well as revisions to the standard form text is available from the author and should be reviewed. A vertical line in the left margin of this document indicates where the author has added necessary information and where the author has added to or deleted from the original AIA text.

This document has important legal consequences. Consultation with an attorney is encouraged with respect to its completion or modification.

AIA Document A201™–2017, General Conditions of the Contract for Construction, is adopted in this document by reference. Do not use with other general conditions unless this document is modified.

including allowances; the Construction Manager's contingency; alternates; the Construction Manager's Fee; and other items that comprise the Guaranteed Maximum Price as defined in Section 3.2.1 of the Agreement.  
(Provide itemized statement below or reference an attachment.)

§ A.1.1.3 The Construction Manager's Fee is set forth in Section 6.1.2 of the Agreement.

§ A.1.1.4 The method of adjustment of the Construction Manager's Fee for changes in the Work is set forth in Section 6.1.3 of the Agreement.

§ A.1.1.5 Alternates

§ A.1.1.5.1 Alternates, if any, included in the Guaranteed Maximum Price:

Item	Price
------	-------

§ A.1.1.5.2 Subject to the conditions noted below, the following alternates may be accepted by the Owner following execution of this Exhibit A. Upon acceptance, the Owner shall issue a Modification to the Agreement.  
(Insert below each alternate and the conditions that must be met for the Owner to accept the alternate.)

Item	Price	Conditions for Acceptance
------	-------	---------------------------

§ A.1.1.6 Unit prices, if any:

(Identify the item and state the unit price and quantity limitations, if any, to which the unit price will be applicable.)

Item	Units and Limitations	Price per Unit (\$0.00)
------	-----------------------	-------------------------

**ARTICLE A.2 DATE OF COMMENCEMENT AND SUBSTANTIAL COMPLETION**

§ A.2.1 The date of commencement of the Work shall be:

(Check one of the following boxes.)

The date of execution of this Amendment.

Established as follows:

(Insert a date or a means to determine the date of commencement of the Work.)

If a date of commencement of the Work is not selected, then the date of commencement shall be the date of execution of this Amendment.

§ A.2.2 Unless otherwise provided, the Contract Time is the period of time, including authorized adjustments, allotted in the Contract Documents for Substantial Completion of the Work. The Contract Time shall be measured from the date of commencement of the Work.

§ A.2.3 Substantial Completion

§ A.2.3.1 Subject to adjustments of the Contract Time as provided in the Contract Documents, the Construction Manager shall achieve Substantial Completion of the entire Work:

(Check one of the following boxes and complete the necessary information.)

Not later than ( ) calendar days from the date of commencement of the Work.

By the following date:

§ A.2.3.2 Subject to adjustments of the Contract Time as provided in the Contract Documents, if portions of the Work are to be completed prior to Substantial Completion of the entire Work, the Construction Manager shall achieve Substantial Completion of such portions by the following dates:

Portion of Work	Substantial Completion Date
-----------------	-----------------------------

§ A.2.3.3 If the Construction Manager fails to achieve Substantial Completion as provided in this Section A.2.3, liquidated damages, if any, shall be assessed as set forth in Section 6.1.6 of the Agreement.

**ARTICLE A.3 INFORMATION UPON WHICH AMENDMENT IS BASED**

§ A.3.1 The Guaranteed Maximum Price and Contract Time set forth in this Amendment are based on the Contract Documents and the following:

§ A.3.1.1 The following Supplementary and other Conditions of the Contract:

Document	Title	Date	Pages
----------	-------	------	-------

§ A.3.1.2 The following Specifications:  
*(Either list the Specifications here, or refer to an exhibit attached to this Amendment.)*

Section	Title	Date	Pages
---------	-------	------	-------

§ A.3.1.3 The following Drawings:  
*(Either list the Drawings here, or refer to an exhibit attached to this Amendment.)*

Number	Title	Date
--------	-------	------

§ A.3.1.4 The Sustainability Plan, if any:  
*(If the Owner identified a Sustainable Objective in the Owner’s Criteria, identify the document or documents that comprise the Sustainability Plan by title, date and number of pages, and include other identifying information. The Sustainability Plan identifies and describes the Sustainable Objective; the targeted Sustainable Measures; implementation strategies selected to achieve the Sustainable Measures; the Owner’s and Construction Manager’s roles and responsibilities associated with achieving the Sustainable Measures; the specific details about design reviews, testing or metrics to verify achievement of each Sustainable Measure; and the Sustainability Documentation required for the Project, as those terms are defined in Exhibit C to the Agreement.)*

Title	Date	Pages
-------	------	-------

Other identifying information:

§ A.3.1.5 Allowances, if any, included in the Guaranteed Maximum Price:  
*(Identify each allowance.)*

Item	Price
------	-------

§ A.3.1.6 Assumptions and clarifications, if any, upon which the Guaranteed Maximum Price is based:  
*(Identify each assumption and clarification.)*

§ A.3.1.7 The Guaranteed Maximum Price is based upon the following other documents and information:  
*(List any other documents or information here, or refer to an exhibit attached to this Amendment.)*

**ARTICLE A.4 CONSTRUCTION MANAGER'S CONSULTANTS, CONTRACTORS, DESIGN PROFESSIONALS, AND SUPPLIERS**

§ A.4.1 The Construction Manager shall retain the consultants, contractors, design professionals, and suppliers, identified below:  
*(List name, discipline, address, and other information.)*

This Amendment to the Agreement entered into as of the day and year first written above.

\_\_\_\_\_  
**OWNER** *(Signature)*

\_\_\_\_\_  
*(Printed name and title)*

\_\_\_\_\_  
**CONSTRUCTION MANAGER** *(Signature)*

\_\_\_\_\_  
*(Printed name and title)*

## **Additions and Deletions Report for AIA® Document A133® – 2019 Exhibit A**

This Additions and Deletions Report, as defined on page 1 of the associated document, reproduces below all text the author has added to the standard form AIA document in order to complete it, as well as any text the author may have added to or deleted from the original AIA text. Added text is shown underlined. Deleted text is indicated with a horizontal line through the original AIA text.

Note: This Additions and Deletions Report is provided for information purposes only and is not incorporated into or constitute any part of the associated AIA document. This Additions and Deletions Report and its associated document were generated simultaneously by AIA software at 10:26:38 ET on 10/16/2025.

*There are no differences.*

# **Certification of Document's Authenticity**

**AIA® Document D401™ – 2003**

I, \_\_\_\_\_, hereby certify, to the best of my knowledge, information and belief, that I created the attached final document simultaneously with its associated Additions and Deletions Report and this certification at 10:26:38 ET on 10/16/2025 under Order No. 4104243742 from AIA Contract Documents software and that in preparing the attached final document I made no changes to the original text of AIA® Document A133™ – 2019 Exhibit A, Guaranteed Maximum Price Amendment, other than those additions and deletions shown in the associated Additions and Deletions Report.

\_\_\_\_\_  
*(Signed)*

\_\_\_\_\_  
*(Title)*

\_\_\_\_\_  
*(Dated)*

# THE WATERFRONT

Working DRAFT

RAMSEY, MN  
OCTOBER 17, 2025  
DF/ DAMON FARBER



DESIGN DEVELOPMENT

# SCHEDULE

WE ARE HERE

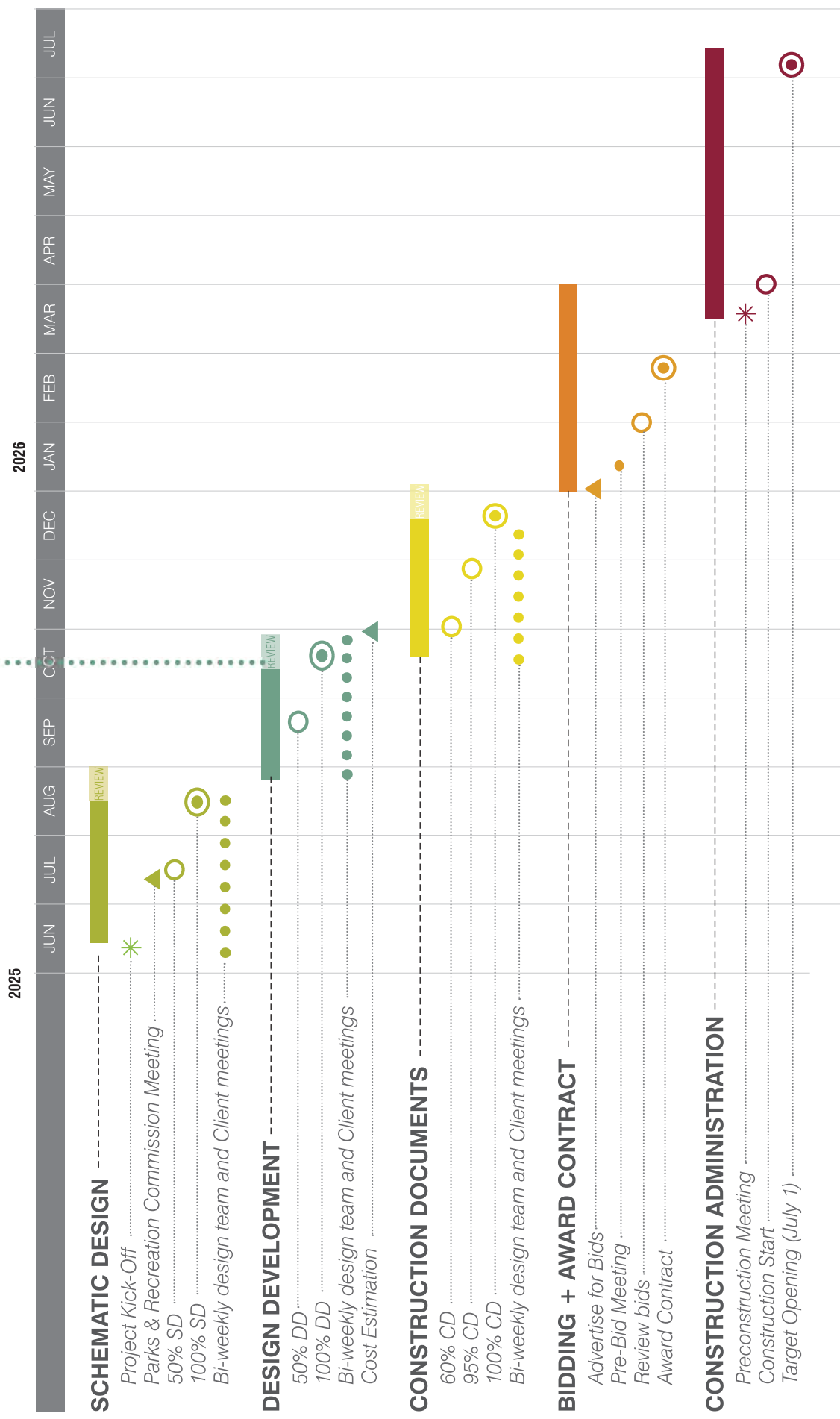

# DD Design

## Overview

# SITE PLAN



# SITE PLAN

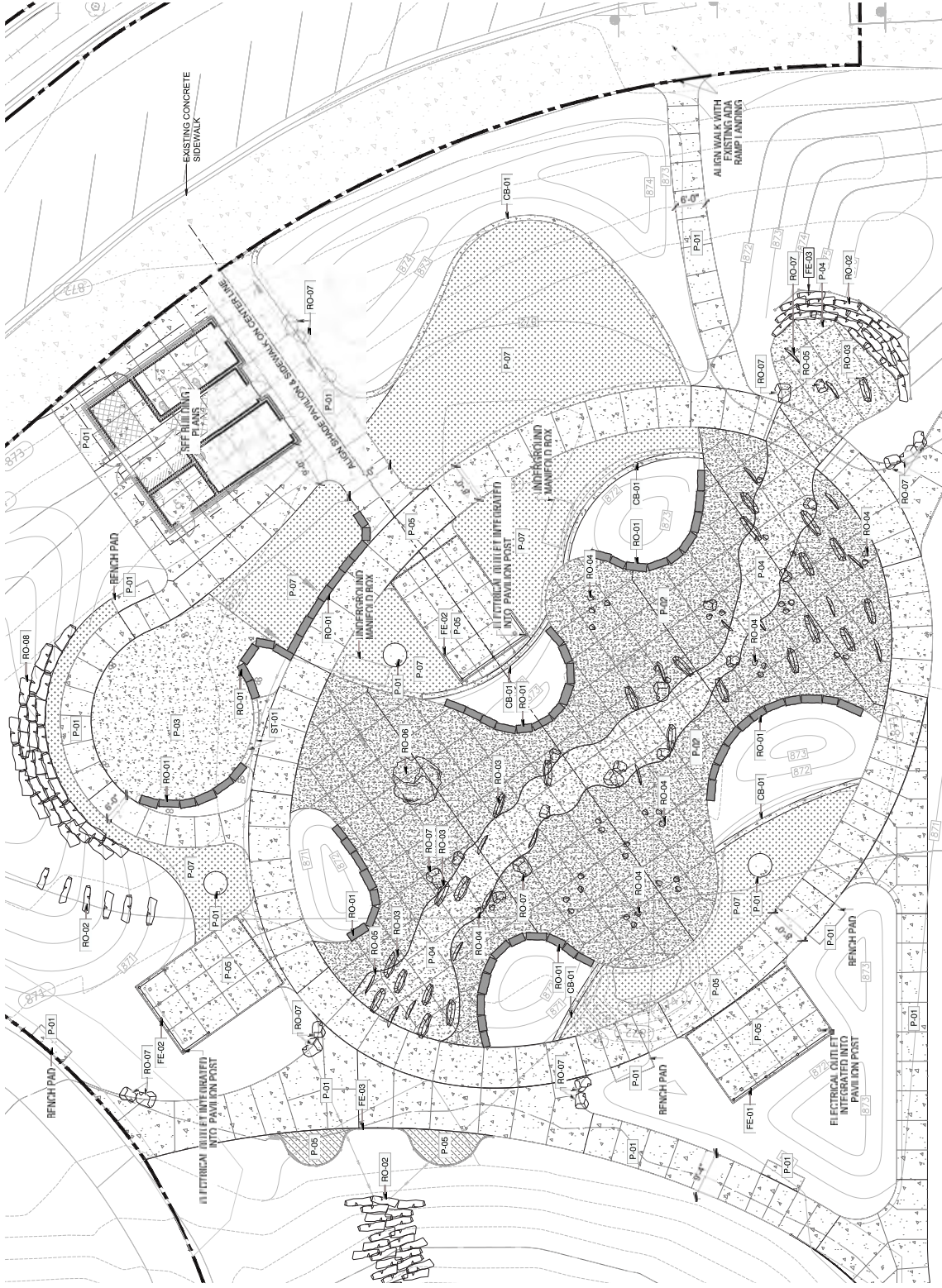

## REFERENCE NOTES SCHEDULE MATERIALS PLAN NORTH

SYMBOL	CODE	DESCRIPTION
	CB-01	CURB TYPE 01 - 12" FLUSH CONCRETE CURB
	P-01	CONCRETE PAVING
	P-02	CONCRETE PAVING
	P-03	CONCRETE PAVING
	P-04	CONCRETE PAVING
	P-05	CONCRETE PAVING
	P-06	CONCRETE PAVING
	P-07	CONCRETE PAVING
	P-08	CONCRETE PAVING
	P-09	CONCRETE PAVING
	P-10	CONCRETE PAVING
	P-11	CONCRETE PAVING
	P-12	CONCRETE PAVING
	P-13	CONCRETE PAVING
	P-14	CONCRETE PAVING
	P-15	CONCRETE PAVING
	P-16	CONCRETE PAVING
	P-17	CONCRETE PAVING
	P-18	CONCRETE PAVING
	P-19	CONCRETE PAVING
	P-20	CONCRETE PAVING
	P-21	CONCRETE PAVING
	P-22	CONCRETE PAVING
	P-23	CONCRETE PAVING
	P-24	CONCRETE PAVING
	P-25	CONCRETE PAVING
	P-26	CONCRETE PAVING
	P-27	CONCRETE PAVING
	P-28	CONCRETE PAVING
	P-29	CONCRETE PAVING
	P-30	CONCRETE PAVING
	P-31	CONCRETE PAVING
	P-32	CONCRETE PAVING
	P-33	CONCRETE PAVING
	P-34	CONCRETE PAVING
	P-35	CONCRETE PAVING
	P-36	CONCRETE PAVING
	P-37	CONCRETE PAVING
	P-38	CONCRETE PAVING
	P-39	CONCRETE PAVING
	P-40	CONCRETE PAVING
	P-41	CONCRETE PAVING
	P-42	CONCRETE PAVING
	P-43	CONCRETE PAVING
	P-44	CONCRETE PAVING
	P-45	CONCRETE PAVING
	P-46	CONCRETE PAVING
	P-47	CONCRETE PAVING
	P-48	CONCRETE PAVING
	P-49	CONCRETE PAVING
	P-50	CONCRETE PAVING
	P-51	CONCRETE PAVING
	P-52	CONCRETE PAVING
	P-53	CONCRETE PAVING
	P-54	CONCRETE PAVING
	P-55	CONCRETE PAVING
	P-56	CONCRETE PAVING
	P-57	CONCRETE PAVING
	P-58	CONCRETE PAVING
	P-59	CONCRETE PAVING
	P-60	CONCRETE PAVING
	P-61	CONCRETE PAVING
	P-62	CONCRETE PAVING
	P-63	CONCRETE PAVING
	P-64	CONCRETE PAVING
	P-65	CONCRETE PAVING
	P-66	CONCRETE PAVING
	P-67	CONCRETE PAVING
	P-68	CONCRETE PAVING
	P-69	CONCRETE PAVING
	P-70	CONCRETE PAVING
	P-71	CONCRETE PAVING
	P-72	CONCRETE PAVING
	P-73	CONCRETE PAVING
	P-74	CONCRETE PAVING
	P-75	CONCRETE PAVING
	P-76	CONCRETE PAVING
	P-77	CONCRETE PAVING
	P-78	CONCRETE PAVING
	P-79	CONCRETE PAVING
	P-80	CONCRETE PAVING
	P-81	CONCRETE PAVING
	P-82	CONCRETE PAVING
	P-83	CONCRETE PAVING
	P-84	CONCRETE PAVING
	P-85	CONCRETE PAVING
	P-86	CONCRETE PAVING
	P-87	CONCRETE PAVING
	P-88	CONCRETE PAVING
	P-89	CONCRETE PAVING
	P-90	CONCRETE PAVING
	P-91	CONCRETE PAVING
	P-92	CONCRETE PAVING
	P-93	CONCRETE PAVING
	P-94	CONCRETE PAVING
	P-95	CONCRETE PAVING
	P-96	CONCRETE PAVING
	P-97	CONCRETE PAVING
	P-98	CONCRETE PAVING
	P-99	CONCRETE PAVING
	P-100	CONCRETE PAVING

# THE PLAZA



# ENTRY FROM STREET CORNER



# THE WATER PLAZA DESIGN



# THE WATER PLAZA DESIGN



# WATERPLAY TODDLER ZONE DESIGN



# WATERPLAY TODDLER ZONE DESIGN

Synthetic Lawn & Adirondack Chairs



Ground Sprays



Lounge Seating



Precast Concrete Gas Fire Pits



Permanent Shade Umbrellas

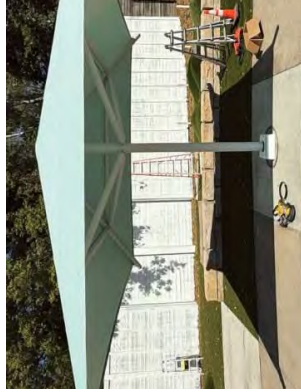

Custom Poles for Catenary Lighting



Decorative Concrete Paving

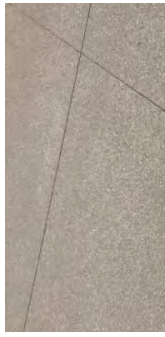

Catenary Lighting - Color Changing

# THE PLAZA / NATURAL STONE

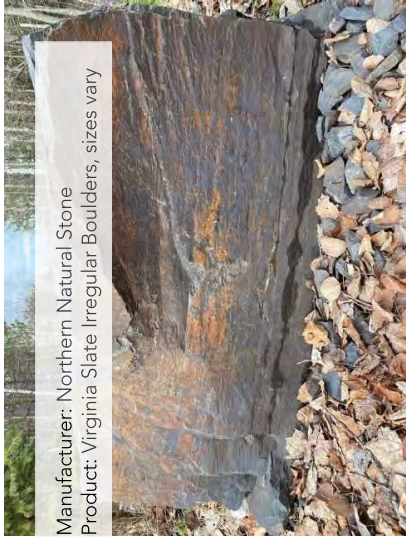

Manufacturer: Northern Natural Stone  
Product: Virginia Slate Irregular Boulders, sizes vary



Manufacturer: Northern Natural Stone  
Product: Virginia Slate Elongated Boulders, sizes vary

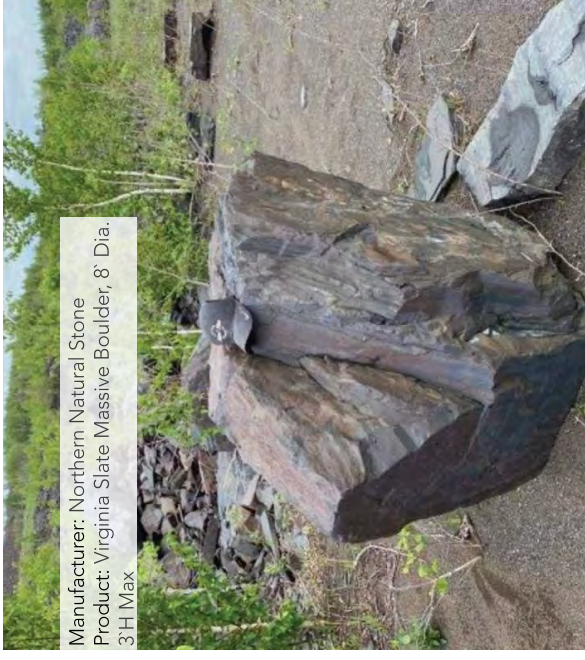

Manufacturer: Northern Natural Stone  
Product: Virginia Slate Massive Boulder, 8' Dia, 3'H Max

# THE PLAZA / TEMPORARY ACTIVATIONS

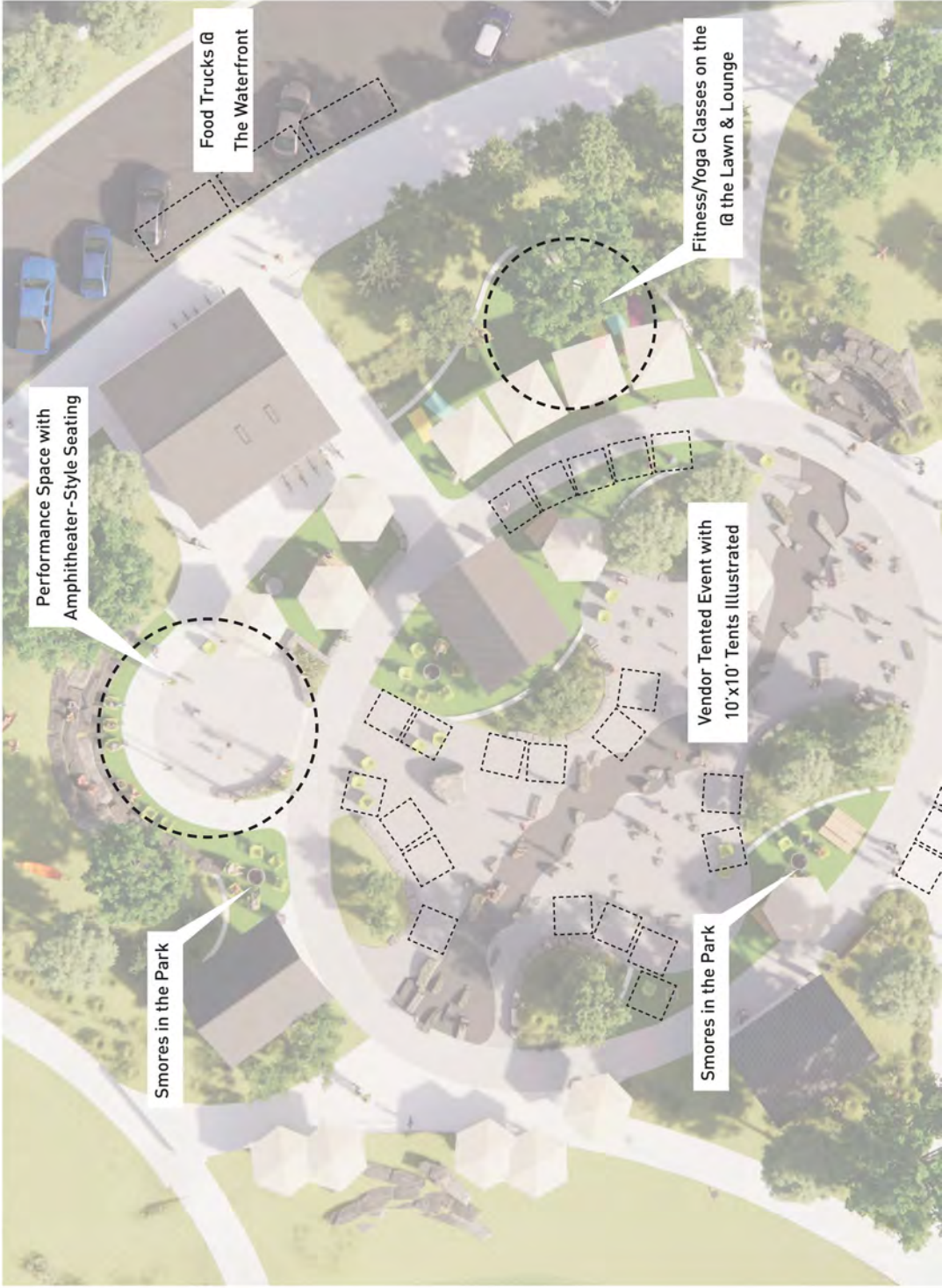

# THE PLAZA / SEATING



- Draft Placeholder diagram to illustrate ...
- linear feet of stone seatwalls
  - highlight benches
  - highlight chairs
  - highlight loungers
  - highlight picnic tables

# THE PLAZA / PUBLIC ART INSPIRATION



# SIGNAGE DESIGN

Dimensional Letter Signage Inspiration



Project Sign Concepts



City Logo Stained on Building



# THE PLAZA / CAPACITY

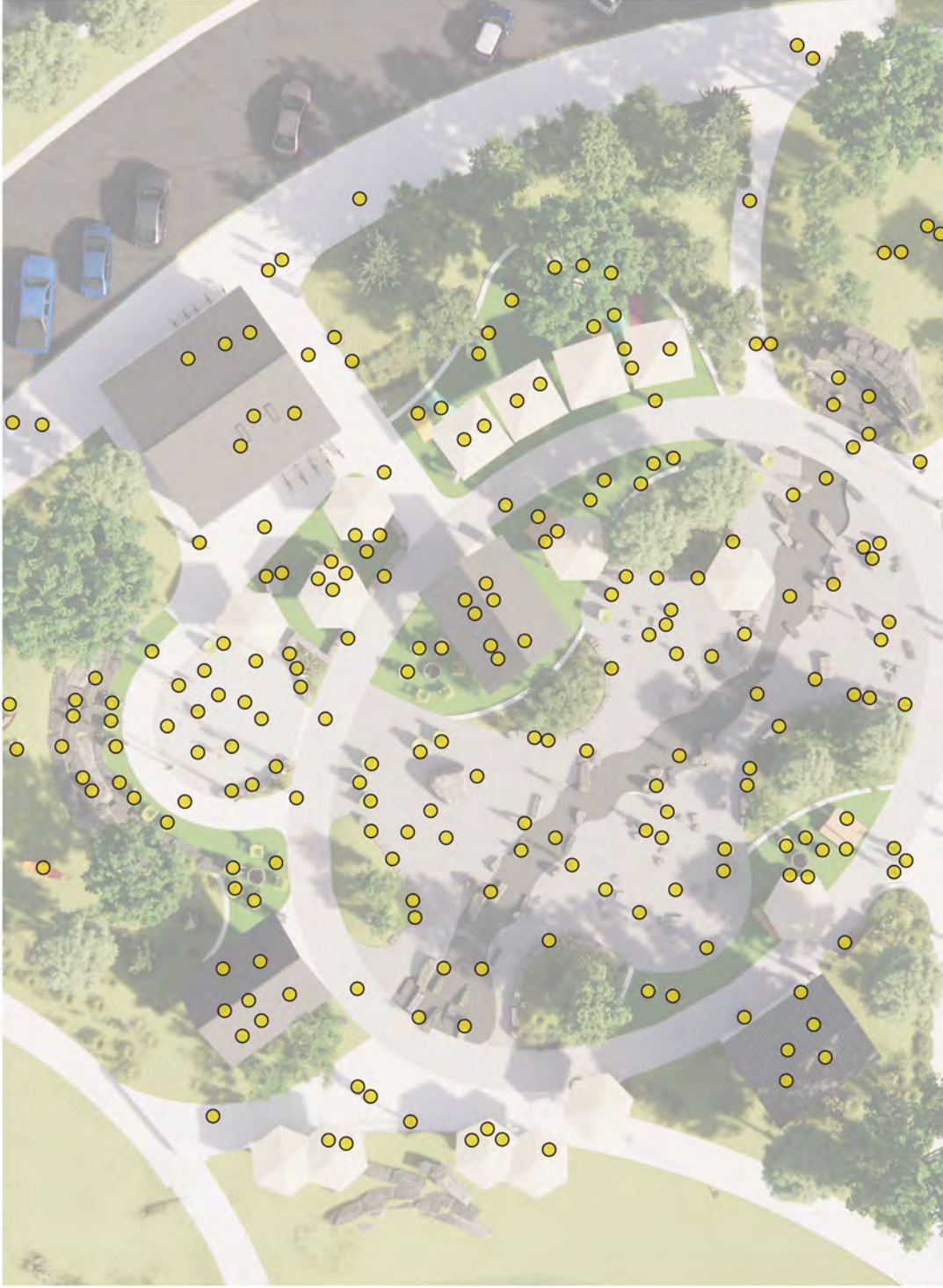

**Key**

Yellow dots illustrate 1-person/  
dot on an average warm weekend  
summer day.

The space can accommodate  
hundreds of people

# THE PLAZA / SUPPORTING UTILITIES

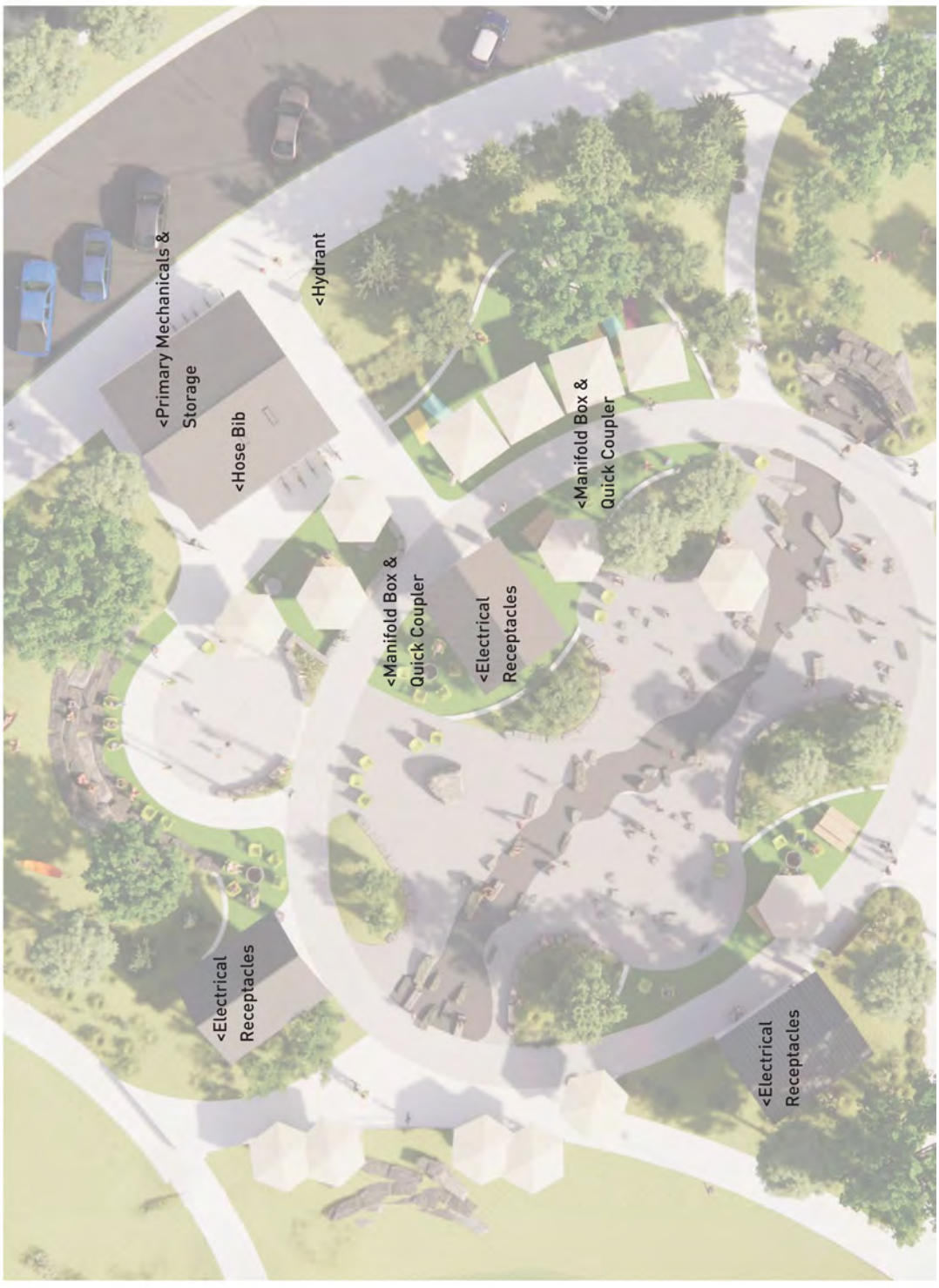

# LAWN & LOUNGE



# LAWN & LOUNGE - AMENITIES

Synthetic Lawn & Adirondack Chairs



Lounge Seating



Permanent Shade Umbrellas

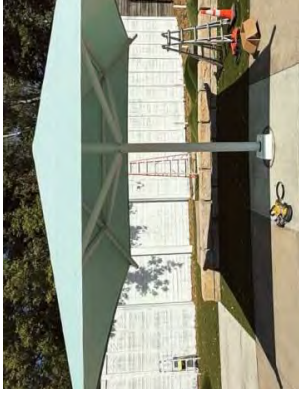

Moveable Picnic Tables



Precast Concrete Gas Fire Pits



HDPE Adirondacks Chairs



Precast Concrete Fire Feature



# OTHER VIEWS



# OTHER VIEWS



# OTHER VIEWS



# OTHER VIEWS



# OTHER VIEWS



# OTHER VIEWS



# Site Structures & Materials

# SITE STRUCTURES

## PAVILIONS



Black Steel Frame & Dark Standing Seam Metal Roofing over T&G Cedar Decking

## PARK BUILDING



Semi-Transparent Gray-Stained Cedar Siding & Dark Standing Seam Metal Roofing

## UMBRELLAS



Powdercoated Steel Frame & Sunbrella Fabric

## FENCES



4' Semi-Solid Screen Fence - Black Aluminum Slats & Fence Posts

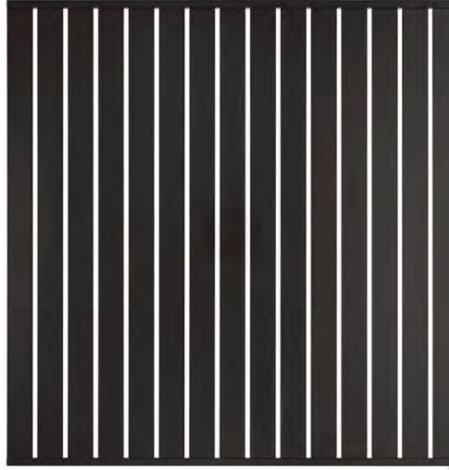

6' Semi-Solid Screen Fence - Black Aluminum Slats & Fence Posts

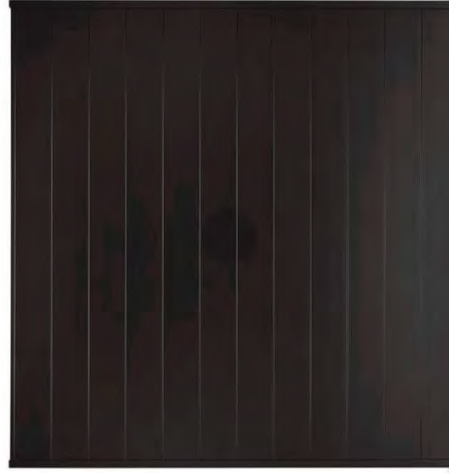

6' Solid Privacy Fence - Black Aluminum Slats & Fence Posts



# PARK PAVILION DESIGN

High-top Serving Tables



Moveable Picnic Tables



Pendant Lights

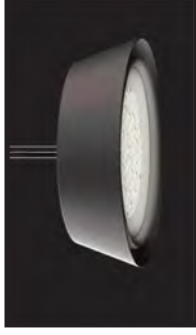

Electrical Receptacles

Towel Hooks

4' High Aluminum Screen Fence



6' High Aluminum Screen Fence

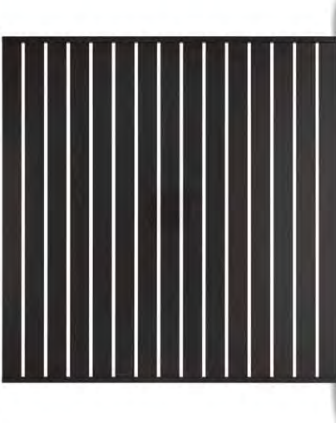

T&G Cedar Roof Underside Decking

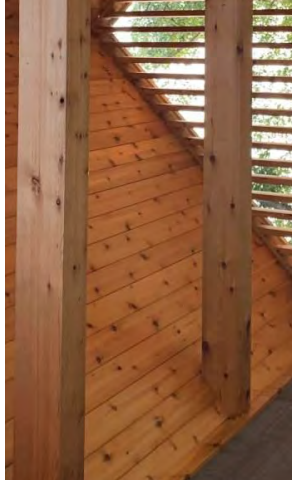

Standing Seam Metal Roof



Decorative Concrete Paving

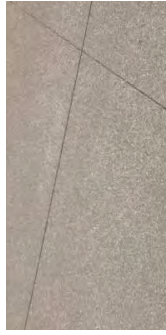

# PARK SUPPORT BUILDING

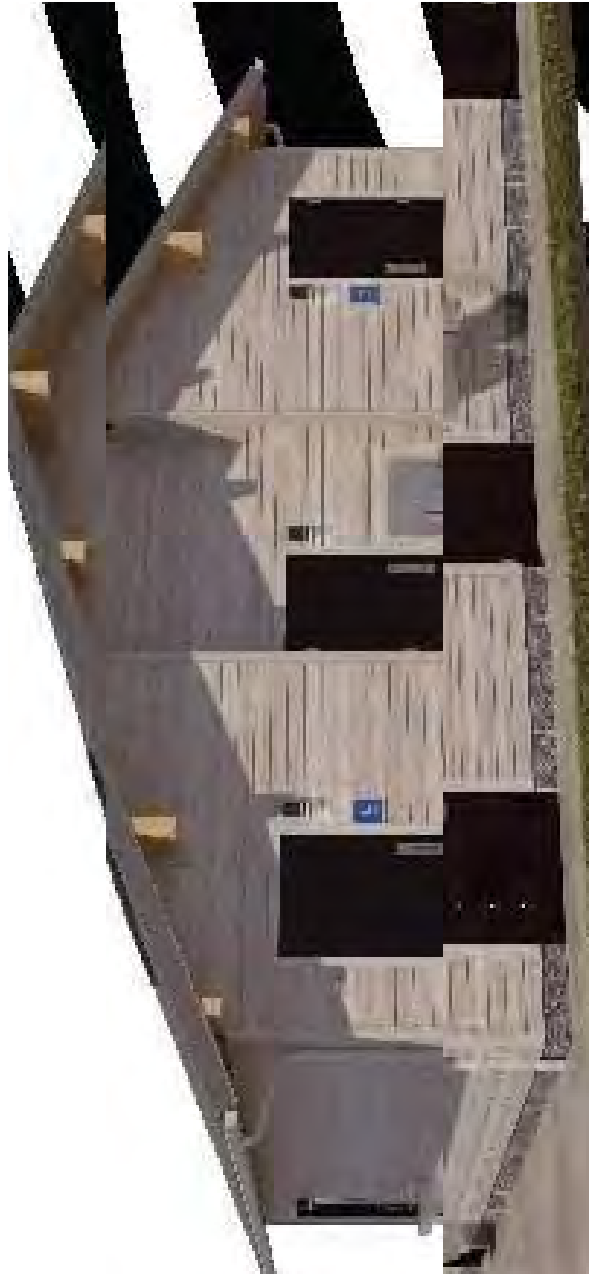
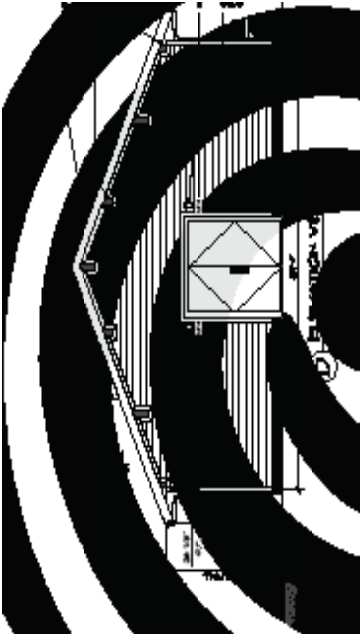
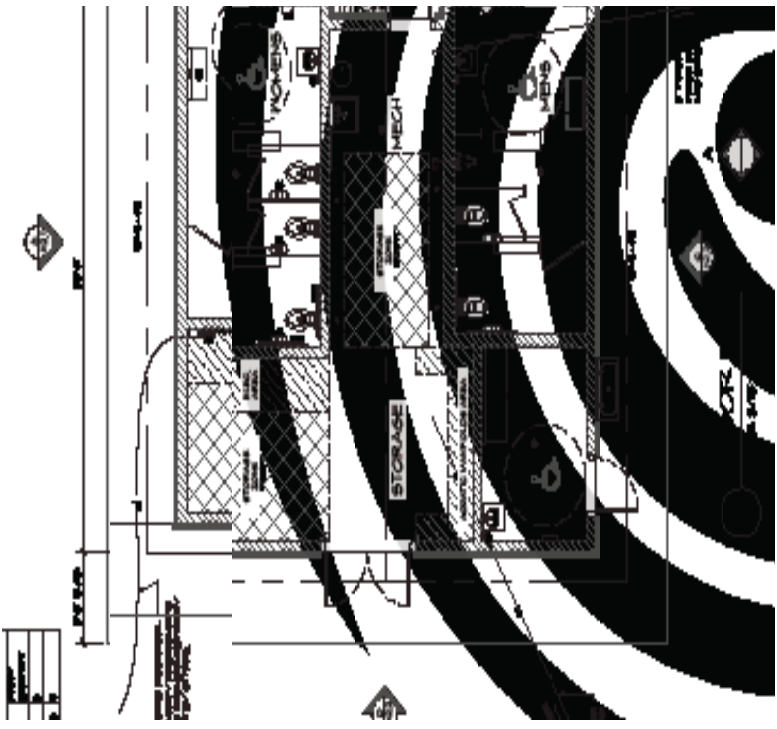

Manufacturer: Romtec  
Product: Semi-Custom Structure  
Summary: Restroom and supply building, cedar lap siding over



# HARDSCAPE MATERIALS

## PAVING

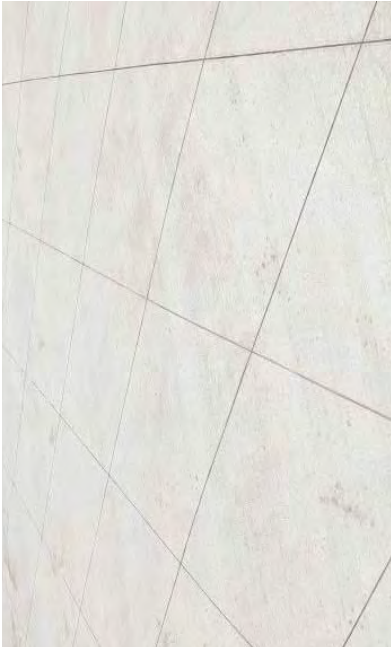

Concrete Paving - Standard Gray Broomed



Decorative Concrete Paving



Decorative Concrete Paving

## STONE & CONCRETE



...

## ACCENT



Synthetic Turf over compacted base

# LIGHTING

## PENDANT IN PAVILIONS

**LUMINIS**

CT151  
**CLERMONT**  
PENDANT/CATENARY

PROJECT NAME: \_\_\_\_\_

ORDERING CODE: \_\_\_\_\_

QUANTITY: \_\_\_\_\_

TYPE: \_\_\_\_\_



① Field adjustable suspension stem or silver braided power cable with aircraft safety cable. Also, offered with a catenary suspension attachment.

② Performance optic series.

③ Corrosion resistant diecast aluminum housing.

④ High efficiency LED light engine with acrylics optics.

⑤ Clear tempered glass.

⑥ All stainless steel hardware.

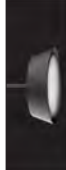

CT151-STM



CT151-SPG



CT151-CAT3

**MATERIALS**

Clermont is made of aluminum diecast offering exceptional precision and durability. The main housing is sealed with durable gasket. LED boards are hidden between coated polymer that diffuses and reflects the light at 90°. It is UV stabilized and antistatic, which does not yellow. The housing is pre-treated inside the main housing, sealed with gasket, and secured with four captive screws which makes it easy for maintenance.

**MOUNTING**

The mounting plate is designed to fit on a 4" (102mm) octagonal electrical box using 3/16" (9.5mm) C/C mounting holes. For STM, fixture must be installed on a finished ceiling for exterior applications and/or when exposed to inclement weather. For CAT3, see option details.

**MEASUREMENTS**

The mounting plate is designed to fit on a 4" (102mm) octagonal electrical box using 3/16" (9.5mm) C/C mounting holes. For STM, fixture must be installed on a finished ceiling for exterior applications and/or when exposed to inclement weather. For CAT3, see option details.

**LED LIGHT ENGINE**

Offered in 2700K, 3000K, 3500K & 4000K / 80CRI, 70% LED lumen maintenance at 60,000 hours (L70/B50) based on IESNA LM-80-08 LED extrapolated life, calculated per IESNA TM-21-21.

**FINISH**

Five-stage preparation process includes: preheating of cast aluminum parts for air extraction, polyester powder coating is applied through an electrostatic process, and oven cured for long term finish.

**CERTIFICATION**

UL Certified to Canadian and U.S. safety standards. Certified for use in wet locations. Rated IP65/IK10. Photometric testing performed by an independent laboratory in accordance with IES LM-79-08 standards at 25°C. Actual performance may differ as a result of end-user environment and application.

**WARRANTY**

5-year limited warranty. This is the only warranty provided and no other statements in this specification sheet create any warranty of any kind. All other express and implied warranties are disclaimed. Complete warranty terms located at: <https://www.alcuburands.com/support/warranty/terms-and-conditions>

**MOUNTING**

The mounting plate is designed to fit on a 4" (102mm) octagonal electrical box using 3/16" (9.5mm) C/C mounting holes. For STM, fixture must be installed on a finished ceiling for exterior applications and/or when exposed to inclement weather. For CAT3, see option details.

**MEASUREMENTS**

Maximum weight: 27 lbs (12 kg)

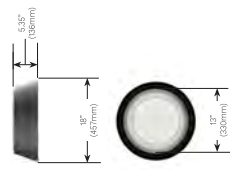

## POST TOP / POLE MOUNT

**LUMINIS**

CT102  
**CLERMONT**  
POST TOP/POLE MOUNT

PROJECT NAME: \_\_\_\_\_

ORDERING CODE: \_\_\_\_\_

QUANTITY: \_\_\_\_\_

TYPE: \_\_\_\_\_

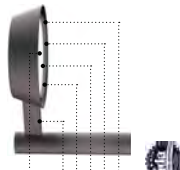

① Comfort optic series.

② Side mount or post-top attachment.

③ Corrosion resistant diecast aluminum housing.

④ Indirect LED lighting on highly reflective dome for visual comfort.

⑤ Clear tempered glass.

⑥ All stainless steel hardware.



CT102-PM



CT102-PT4

**MATERIALS**

Clermont is made of aluminum diecast offering exceptional precision and durability. The main housing is sealed with durable gasket. LED boards are hidden between coated polymer that diffuses and reflects the light at 90°. It is UV stabilized and antistatic, which does not yellow. The housing is pre-treated inside the main housing, sealed with gasket, and secured with four captive screws which makes it easy for maintenance.

**ELECTRICAL DRIVER**

Standard driver is 0-10V dimming-ready (dims to 10%) with: 120-277 multi-volt compatibility (50-60Hz), operating temperature range of -40°C to +55°C -40°F to +131°F, output over voltage protection, output over current protection and output short circuit protection with auto-recovery. Optional 347/480V available.

**LED LIGHT ENGINE**

Offered in 2700K, 3000K, 3500K & 4000K / 80CRI, 70% LED lumen maintenance at 60,000 hours (L70/B50) based on IESNA LM-80-08 LED extrapolated life, calculated per IESNA TM-21-21.

**FINISH**

Five-stage preparation process includes: preheating of cast aluminum parts for air extraction, polyester powder coating is applied through an electrostatic process, and oven cured for long term finish.

**CERTIFICATION**

UL Certified to Canadian and U.S. safety standards. Certified for use in wet locations. Rated IP65/IK10. Photometric testing performed by an independent laboratory in accordance with IES LM-79-08 standards at 25°C. Actual performance may differ as a result of end-user environment and application.

**WARRANTY**

5-year limited warranty. This is the only warranty provided and no other statements in this specification sheet create any warranty of any kind. All other express and implied warranties are disclaimed. Complete warranty terms located at: <https://www.alcuburands.com/support/warranty/terms-and-conditions>

**MOUNTING**

For PM mounting: designed to fit on 4" or 5" OD poles. For PT4 mounting: designed to fit on 4" OD pole with 1/4", 3/16" or 1/8" wall thickness.

**MEASUREMENTS**

Maximum weight: 40 lbs (18 kg)

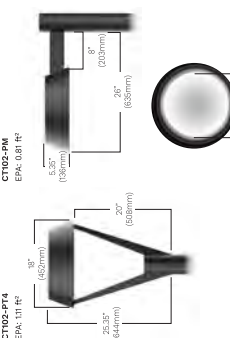

**MATERIALS**

Clermont is made of aluminum diecast offering exceptional precision and durability. The main housing is sealed with durable gasket. LED boards are hidden between coated polymer that diffuses and reflects the light at 90°. It is UV stabilized and antistatic, which does not yellow. The housing is pre-treated inside the main housing, sealed with gasket, and secured with four captive screws which makes it easy for maintenance.

**ELECTRICAL DRIVER**

Standard driver is 0-10V dimming-ready (dims to 10%) with: 120-277 multi-volt compatibility (50-60Hz), operating temperature range of -40°C to +55°C -40°F to +131°F, output over voltage protection, output over current protection and output short circuit protection with auto-recovery. Optional 347/480V available.

**LED LIGHT ENGINE**

Offered in 2700K, 3000K, 3500K & 4000K / 80CRI, 70% LED lumen maintenance at 60,000 hours (L70/B50) based on IESNA LM-80-08 LED extrapolated life, calculated per IESNA TM-21-21.

**FINISH**

Five-stage preparation process includes: preheating of cast aluminum parts for air extraction, polyester powder coating is applied through an electrostatic process, and oven cured for long term finish.

**CERTIFICATION**

UL Certified to Canadian and U.S. safety standards. Certified for use in wet locations. Rated IP65/IK10. Photometric testing performed by an independent laboratory in accordance with IES LM-79-08 standards at 25°C. Actual performance may differ as a result of end-user environment and application.

# LIGHTING

## CATENARY CABLE MOUNT



**HK LIGHTING**

Project Name \_\_\_\_\_

Fixture Type \_\_\_\_\_



**ZXL11-CAT-ACRY**  
LED Catenary - ZXL11 Series

**Product Features**

- 4 unique catenary systems including LED fixtures, turnbuckle suspension cable, power cable for outdoor or indoor illumination.
- IP65 standard.
- Machined from solid billet 6061-T6 corrosion resistant aluminum.
- Modular components - field changeable LED
- Brushed acrylic hood provides even glow through out, and subtle lighting around the fixture in addition to the down light.



**Material:** Extruded from 6061-T6 corrosion resistant aluminum with 304 stainless steel hardware. Available in 12V or 120V/277V. Hood: Brushed acrylic rod.

**Lamp Base / Socket:** Innovative, cone-shaped lamp base with 1/2" diameter. Available in 12V or 120V/277V. To dissipate heat more effectively. See "Resource" for details.

**Finish:** Polyester powder coat on all aluminum materials with complimentary processors. Anodized aluminum suspension cable and turnbuckle are provided with a brushed surface.

**Voltage:** 12V/AC/DC. Requires remote step down transformer.

**Weight:** 5 or 7W HK LED.

**Dimmability:** MLX.

**Optical Accessories:** Dichroic color filters. Secured in place with 1/8" stainless steel screws. See page 2 for more info.

**Mounting Method:** Custom hook mechanism on top of fixture that utilizes set screws to secure (turnup) on the turnbuckle suspension cable and to lock the position of fixture on the cable.

**Turn Buckle (Optional):** Allows fine tuning of the tension on the support cable, up to 120° or adjustment.

**Power Cable (Optional):** 18/23 12V cable, dia.0.29". 277 aluminum cable, dia.0.3150".

**Ordering Guide**

Series	Material	Voltage	Wattage	CT	Finish	Optic/Accessories	Mounting/Accessories
ZXL11-CAT-ACRY	MLX	12V	5 or 7W	32	2000K	Standard	See page 2 for more info.
	BLK BK			32	2000K	Black Powder Coat	
	SI			32	2000K	White Powder Coat	
	WT			40	4000K	White Powder Coat	
	ASZ					Anodized Brush	
	CC					Custom Powder Coat	

**Product Drawings**

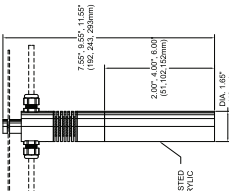

Remotes: Step Down Transformer (Optional). See Accessories link for details specification.

Mount: Watertight. Primary Voltage(VAC), Secondary Voltage(VAC), Dimming Method, Characters

TMW	12V	120 or 277	MLX	Outdoor, Half Moon, Compact
12V	120	120 or 277	MLX	Outdoor, Half Moon, Compact
12V	120	120 or 277	MLX	Outdoor, Half Moon, Compact
12V	120 only	120 or 277	MLX	Outdoor, Half Moon, Compact

NOTE: Specification and dimensions subject to change without notice.

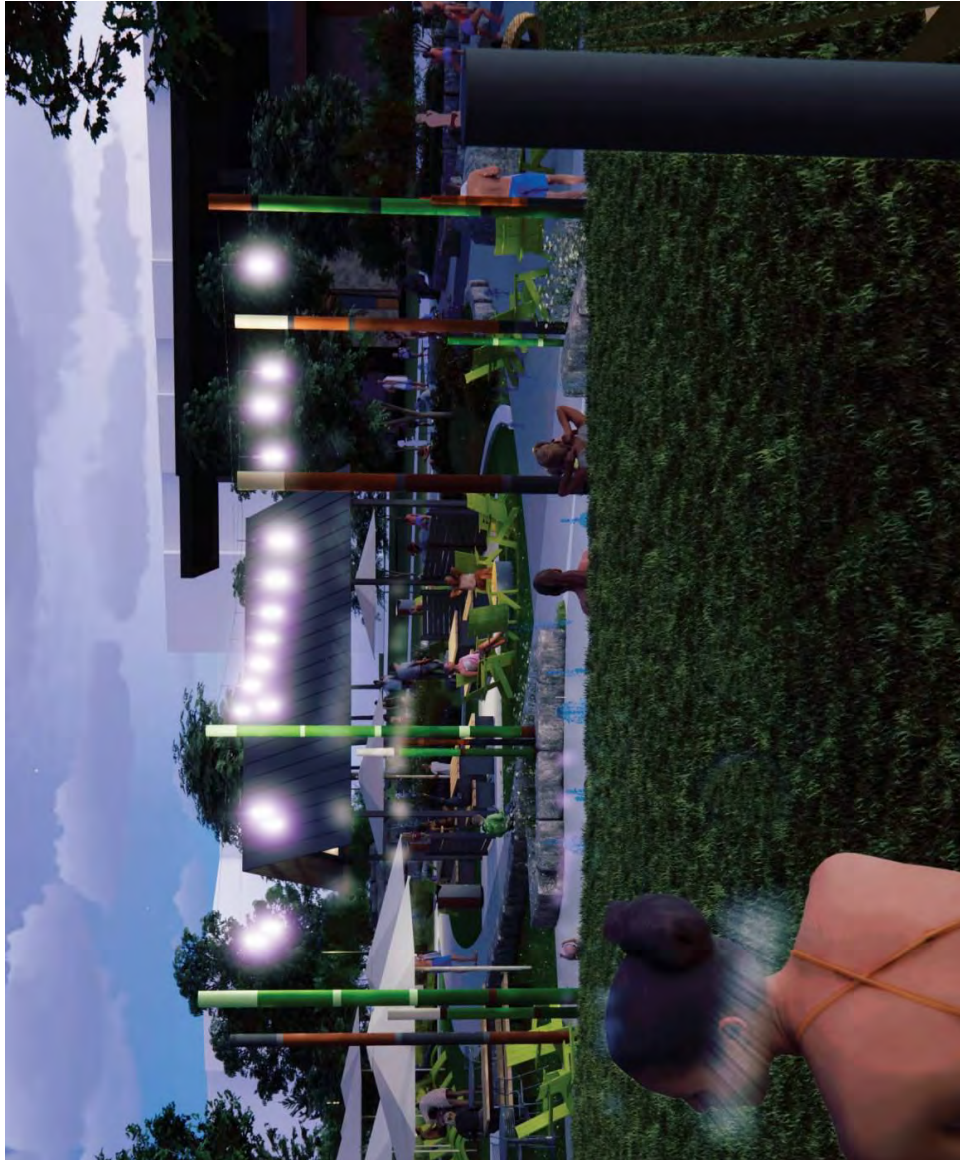

# SITE FURNISHINGS

## BENCHES + ADIRONDACKS



Manufacturer: Maglin  
Product: Iconic Backed Bench w/ Side Arms

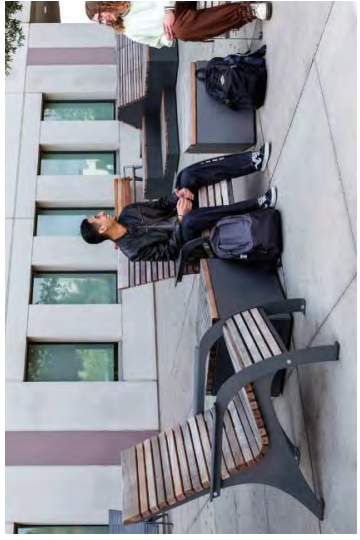

Manufacturer: Maglin  
Product: 720 Series Lounge Chair



Manufacturer: Maglin  
Product: 720 Series Chaise Lounge

## TABLES + CHAIRS / DINING

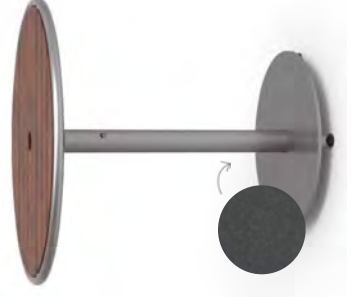

Manufacturer: Maglin  
Product: 1700 Series Foro Round Table



Manufacturer: Maglin  
Product: 1700 Series Foro Standard Chair  
(w/ & w/o arms)



Manufacturer: Maglin  
Product: 210 Cluster Seating

# SITE FURNISHINGS

## COUNTER TABLE



Manufacturer: Forms & Surfaces  
Product: Avivo Bar Table - Cumaru

## RECEPTACLES



Manufacturer: Forms & Surfaces  
Product: Tonyo Split Stream - Cumaru

## FIRE TABLE

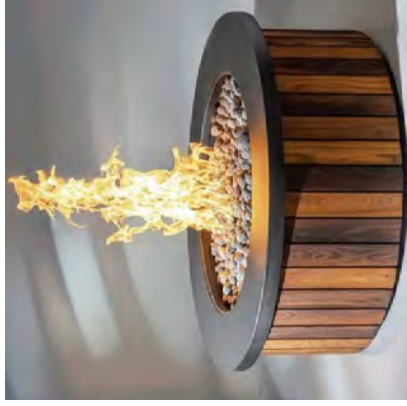

Manufacturer: Montana Fire Pits  
Product: Sequoia Arbor Wood Fire Pit Table (Matching Cover Option Available)

## BIKE SECURE STORAGE

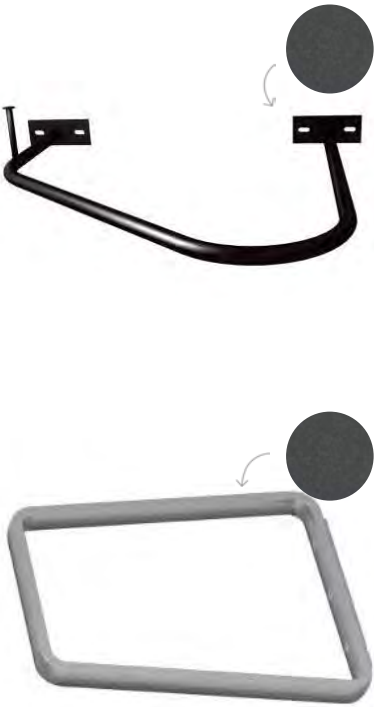

Manufacturer: Maglin  
Product: 2300 Series Iconic Bike Rack

Manufacturer: Dero  
Product: Ultra Space Saver Single



# Planting Design

# PLANTING INSPIRATION



# PLANTING INSPIRATION



# PLANTING INSPIRATION



# PLANTING INSPIRATION



# TREE CANOPY PALETTE SAMPLING

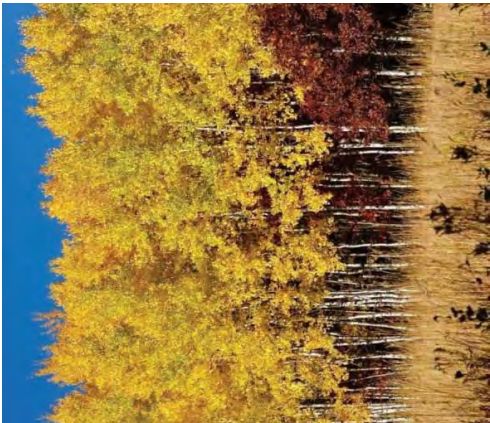
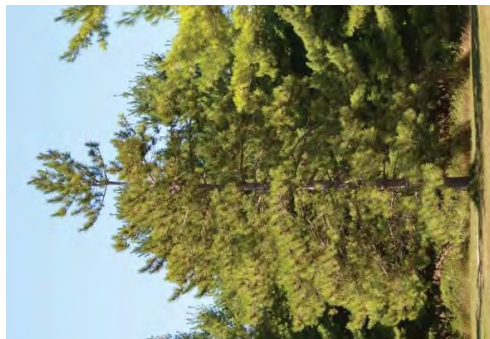
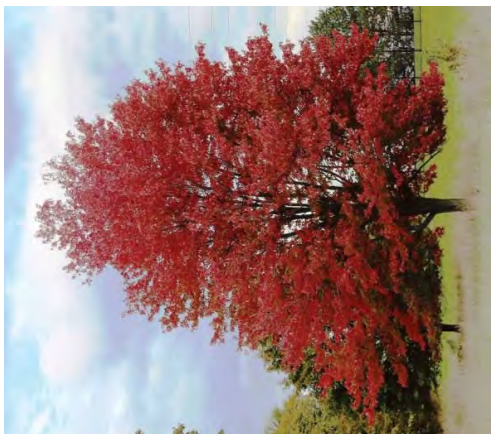

# UNDERSTORY PALETTE SAMPLING

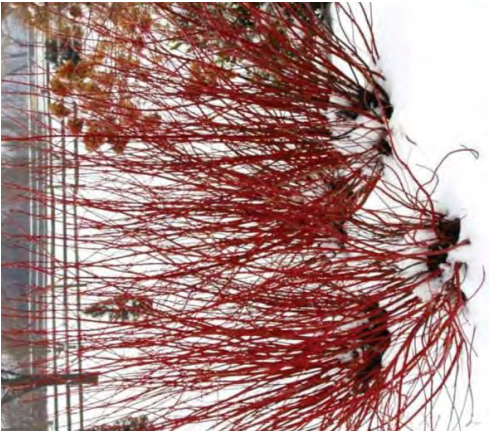

# Architecture

# PARK SUPPORT BUILDING





# ELEVATIONS

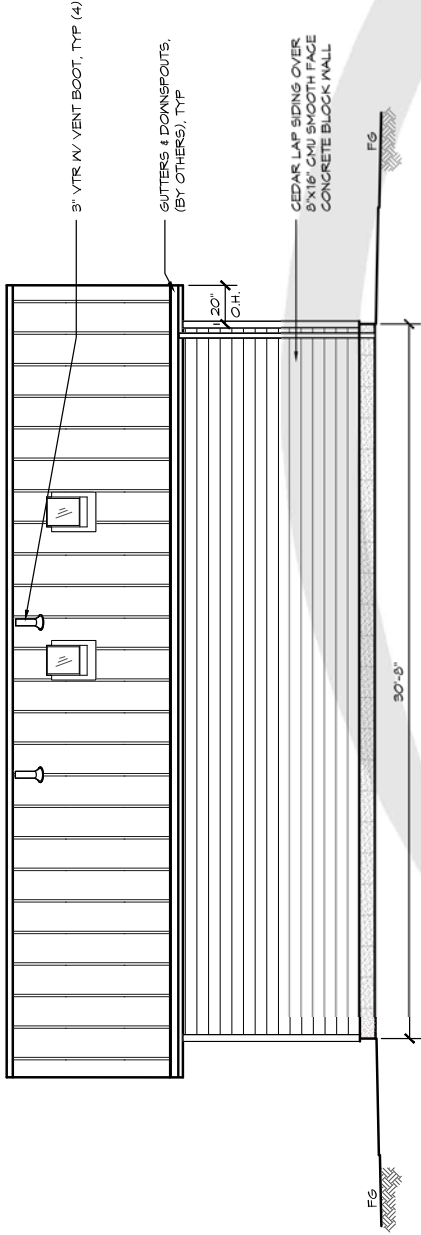

**A** ELEVATION VIEW  
SCALE: 3/16" = 1'-0"

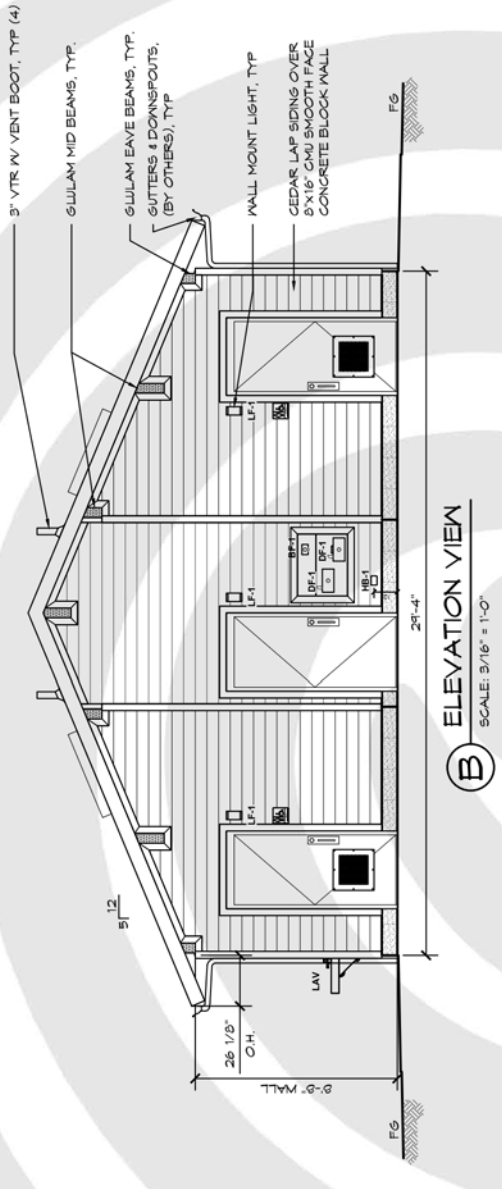

**B** ELEVATION VIEW  
SCALE: 3/16" = 1'-0"

# ELEVATIONS

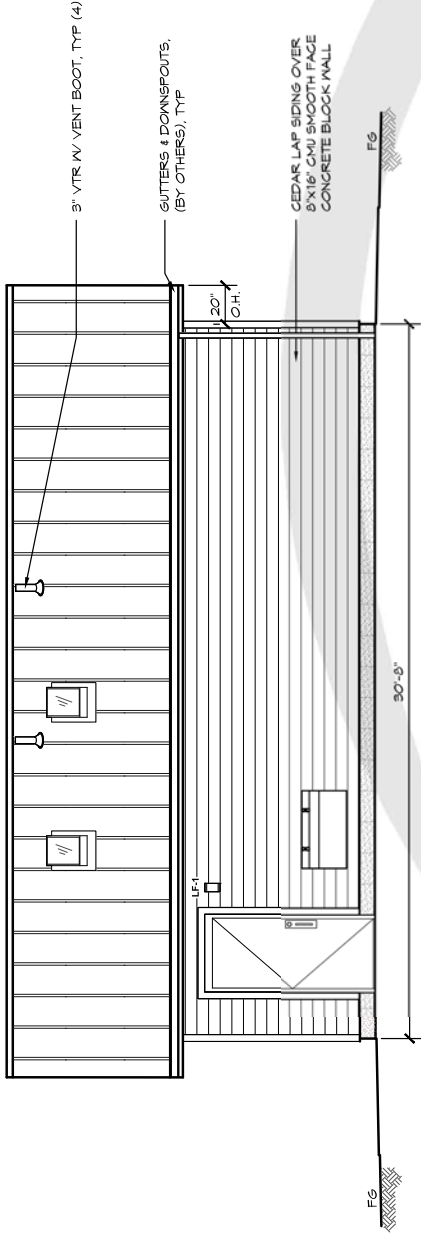

**C** ELEVATION VIEW  
SCALE: 3/16" = 1'-0"

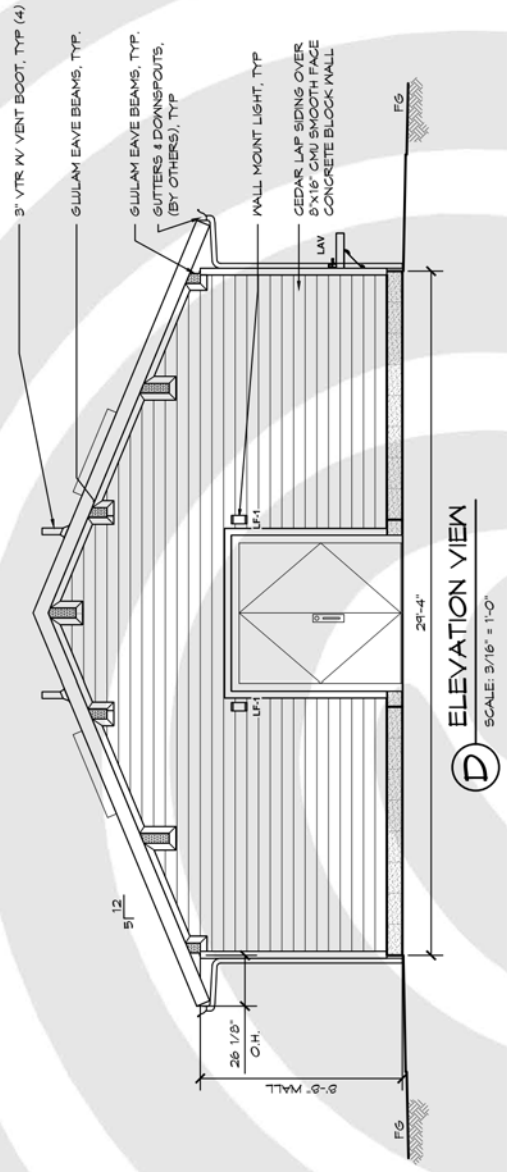

**D** ELEVATION VIEW  
SCALE: 3/16" = 1'-0"

# VIEWS



# FUTURE COMMUNITY BUILDING

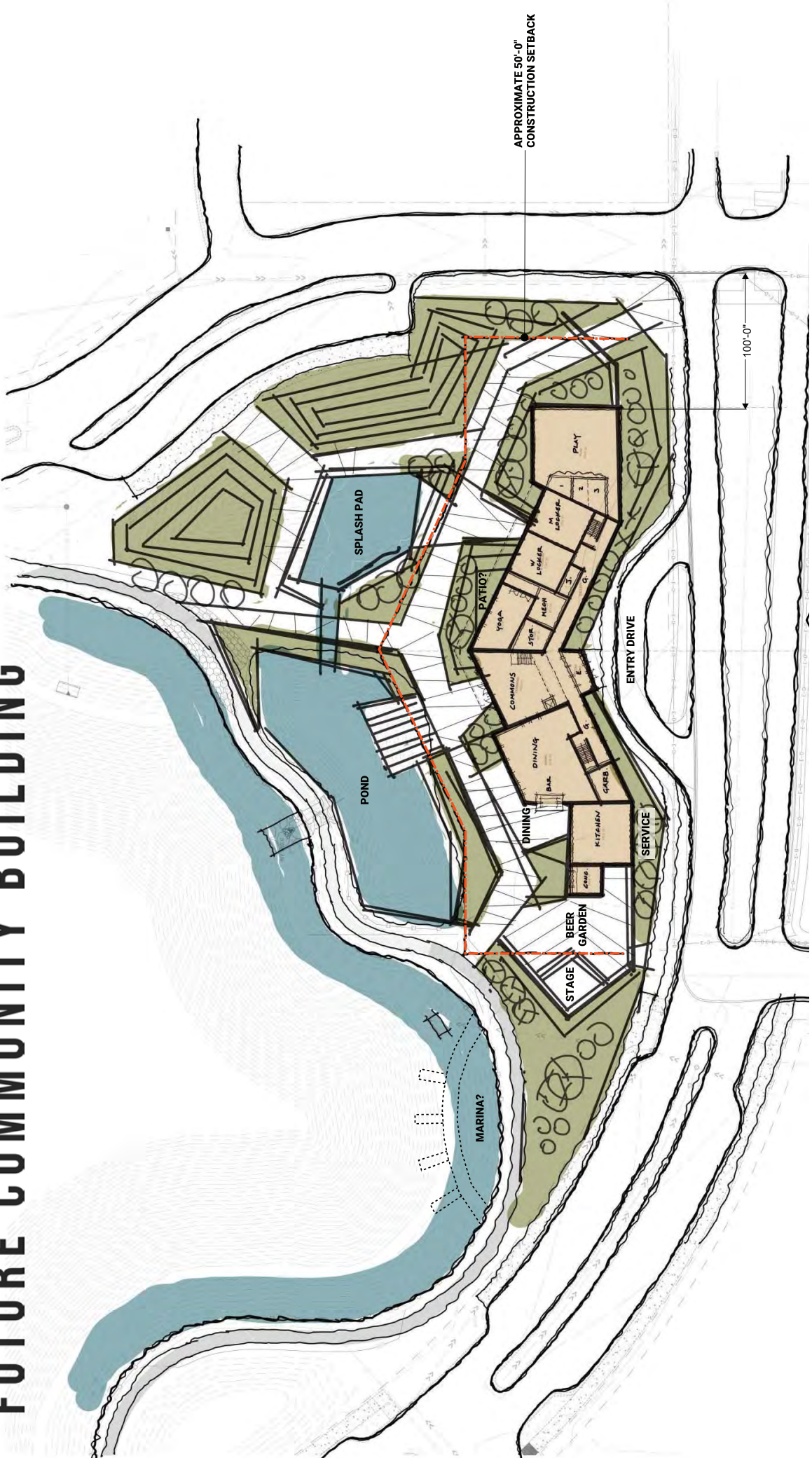

APPROXIMATE 50'-0"  
CONSTRUCTION SETBACK

100'-0"

# THE WATERFRONT



**THE WATERFRONT WATERPLAY  
CITY OF RAMSEY**

RAMSEY, MN  
DAMON FABER LANDSCAPE ARCHITECTS  
SD ESTIMATE  
10/23/2025 - UPDATE

*Preliminary  
Estimate*



Construction Start: 2/2/2026  
Construction Completion: 6/30/2026

DESCRIPTION	QUANTITY/UNITS	UNIT COST	TOTAL
<b>BATHROOM BLDG / SHELTERS</b>			
BATHROOM BLDG CONCRETE FOUNDATIONS/INST/	1 LSUM	\$ 80,000.00	\$ 80,000
SHELTERS CONCRETE FOOTINGS/INSTALL	3 LSUM	\$ 20,000.00	\$ 60,000
<b>AQUATIC EQUIPMENT</b>			
AQUATIC EQUIPMENT	1 LSUM	\$ 450,000.00	\$ 450,000
<b>MECHANICAL</b>			
SITEWIDE MECHANICAL (NOT SPLASHPAD)	1 LSUM	\$ 40,000.00	\$ 40,000
<b>ELECTRICAL</b>			
SITE LIGHTING - POLES	13 EA	\$ 10,000.00	\$ 130,000
SITE LIGHTING - ROPE	5 EA	\$ 5,000.00	\$ 25,000
SITE LIGHTING - SHELTERS	3 EA	\$ 7,500.00	\$ 22,500
BUILDING/SITE POWER	1 LSUM	\$ 100,000.00	\$ 100,000
SITE LOW VOLTAGE	1 LSUM	\$ 25,000.00	\$ 25,000
<b>EARTHWORK</b>			
SITE GRADING/SUBGRADE PREP	1 LSUM	\$ 120,000.00	\$ 120,000
BUILDING EXCAVATION/SUBGRADE PLACE/LANDSC	1 LSUM	\$ 40,000.00	\$ 40,000
4" DRAIN TILE	450 LNFT	\$ 50.00	\$ 22,500
<b>PAVING/CONCRETE</b>			
CURB TYPE 01 - 12" FLUSH CONCRETE CURB	300 SF	\$ 50.00	\$ 15,000
PAVING TYPE 01 - CONCRETE PAVING	400 SF	\$ 12.00	\$ 4,800
PAVING TYPE 02 - DECORATIVE CONCRETE PAVING	5206 SF	\$ 25.00	\$ 130,150
PAVING TYPE 03 - DECORATIVE CONCRETE PAVING	1229 SF	\$ 25.00	\$ 30,725
PAVING TYPE 04 - DECORATIVE CONCRETE PAVING	1521 SF	\$ 25.00	\$ 38,025
PAVING TYPE 05 - DECORATIVE STONE PAVING	3200 SF	\$ 50.00	\$ 160,000
PAVING TYPE 07 - SYNTHETIC TURF	3828 SF	\$ 12.00	\$ 45,936
PAVING GLOW ROCK	1 LSUM	\$ 10,000.00	\$ 10,000
<b>LANDSCAPING</b>			
ROCK TYPE 01 - STONE SEAT WALL	47 EA	\$ 1,250.00	\$ 58,750
ROCK TYPE 02 - STONE @ "GLACIAL OUTWASH", "IC	33 EA	\$ 1,000.00	\$ 33,000
ROCK TYPE 03 - STONE @ "KAME CREST"	24 EA	\$ 750.00	\$ 18,000
ROCK TYPE 04 - STONE @ "GEYSER MEADOW"	40 EA	\$ 200.00	\$ 8,000
ROCK TYPE 05 - STONE @ "GLACIAL TERMINUS"	18 EA	\$ 500.00	\$ 9,000
ROCK TYPE 06 - STONE @ "ERRATIC FIELD"	1 EA	\$ 5,000.00	\$ 5,000

ROCK TYPE 07 - STONE @ "MEANDER"	16	EA	\$	500.00	\$	8,000
ROCK TYPE 08 - STONE @ "ROCKFALL SEATING"	30	EA	\$	1,500.00	\$	45,000
AMENITY TYPE 03 - BRIDGE	1	LSUM	\$	25,000.00	\$	25,000
AMENITY TYPE 04 - GAS FIRE TABLE	3	EA	\$	15,000.00	\$	45,000
FENCE TYPE 01 - SCREEN FENCE - 4 FOOT HGT.	55	LNFT	\$	400.00	\$	22,000
FENCE TYPE 02 - SCREEN FENCE - 6 FOOT HGT.	22	LNFT	\$	500.00	\$	11,000
GUARDRAIL TYPE 01 - GUARDRAIL	20	LNFT	\$	175.00	\$	3,500
DECIDIOUS TREE LARGE	28	EA	\$	1,500.00	\$	42,000
ORNAMENTAL TREE	28	EA	\$	1,000.00	\$	28,000
CONIFEROUS TREE	12	EA	\$	1,250.00	\$	15,000
DECIDIOUS TREE MEDIUM	20	EA	\$	800.00	\$	16,000
MULTI STEM SHRUB / SMALL TREE	6	EA	\$	500.00	\$	3,000
TURF GRASS	9930	SF	\$	2.00	\$	19,860
NATIVE LANDSCAPE BED	22000	SF	\$	3.00	\$	66,000
LANDSCAPE EDGING	1000	LNFT	\$	5.00	\$	5,000
IRRIGATION	1	LSUM	\$	150,000.00	\$	150,000
PLANTING SOILS	100	CY	\$	75.00	\$	7,500

---

**SUBTOTAL H+U PROVIDED CONSTRUCTION COSTS** **\$ 2,193,246**

---

<b>PRECONSTRUCTION SERVICES</b>					\$	50,000
<b>CMAR FEES &amp; REIMBURSABLES</b>					\$	400,000
<b>GENERAL CONDITIONS</b>					\$	125,000
<b>PERMITTING</b>					\$	15,000
<b>UTILITY SERVICE PROVIDER FEES</b>					\$	35,000
<b>BOND</b>		1.00%			\$	21,932
<b>CONSTRUCTION CONTINGENCY</b>		5.00%			\$	109,662
<b>BUILDERS RISK POLICY</b>					\$	10,000

---

**TOTAL H+U CONSTRUCTION COSTS** **\$ 2,959,841**

---

**OWNER FURNISHED ITEMS**

UTILITY WORK - WATER AND SANITARY	1	LSUM	\$	148,000.00	\$	148,000
AMENITY TYPE 01 - PAVILION - 16' X 24'	3	EA	\$	55,000.00	\$	165,000
AMENITY TYPE 02 - PARK SUPPORT BUILDING / BAT	1	EA	\$	370,000.00	\$	370,000
AMENITY TYPE 06 - SQUARE UMBRELLA	4	EA	\$	2,500.00	\$	10,000
SITE FURNISHING TYPE 01A - BIKE RACK	13	EA	\$	500.00	\$	6,500
SITE FURNISHING TYPE 01B - WALL MOUNT BIKE RA	2	EA	\$	4,000.00	\$	8,000
SITE FURNISHING TYPE 02 - TRASH RECEPTACLE	7	EA	\$	2,600.00	\$	18,200
SITE FURNISHING TYPE 03 - ADIRONDACK CHAIR	43	EA	\$	1,500.00	\$	64,500
SITE FURNISHING TYPE 04 - CHAISE LOUNGE	8	EA	\$	1,750.00	\$	14,000
SITE FURNISHING TYPE 05 - CAFE TABLE	5	EA	\$	2,500.00	\$	12,500
SITE FURNISHING TYPE 06A - CAFE CHAIR - ARMLES	10	EA	\$	1,000.00	\$	10,000
SITE FURNISHING TYPE 06B - CAFE CHAIR - WITH AF	10	EA	\$	1,250.00	\$	12,500
SITE FURNISHING TYPE 07 - BACKED BENCH	6	EA	\$	6,000.00	\$	36,000
SITE FURNISHING TYPE 08 - PICNIC TABLE	15	EA	\$	6,000.00	\$	90,000
SITE FURNISHING TYPE 09 - BACKLESS PICNIC BENC	30	EA	\$	6,000.00	\$	180,000
SITE FURNISHING TYPE 10 - FREESTANDING UMBRE	11	EA	\$	3,000.00	\$	33,000

SITE FURNISHING TYPE 11 - COUNTER TABLE	6	EA	\$	2,000.00	\$	12,000
---	---	----	----	----------	----	--------

---

<b>TOTAL OWNER FURNISHED ESTIMATED COSTS</b>					<b>\$</b>	<b>1,190,200</b>
--	--	--	--	--	-----------	------------------

---

<b>DESIGN CONTINGENCY APPLIED TO ALL COSTS</b>	10.00%				<b>\$</b>	<b>415,004</b>
--	--------	--	--	--	-----------	----------------

OWNER CONTINGENCY						BY OWNER
-------------------	--	--	--	--	--	----------

DESIGN FEES						BY OWNER
-------------	--	--	--	--	--	----------

FURNISHINGS, FIXTURES & EQUIPMENT						BY OWNER
-----------------------------------	--	--	--	--	--	----------

SAC/WAC FEES						BY OWNER
--------------	--	--	--	--	--	----------

---

<b>TOTAL PROJECT COSTS</b>					<b>\$</b>	<b>4,565,045</b>
----------------------------	--	--	--	--	-----------	------------------

---

TBD {